

EX LIBRIS









TA670  
S5

5/12/21

Copyright 1921,  
By FREDERICK P. SPALDING

TO THE  
LIBRARY OF

PRESS OF  
BRAUNWORTH & CO.  
BOOK MANUFACTURERS  
BROOKLYN, N. Y.

## PREFACE

---

THIS book is designed to present, in a brief and systematic manner, the fundamental principles involved in the design and construction of masonry structures.

The term Masonry has been construed to include concrete, and the field covered by the title is a very wide one. It has therefore been necessary to select for discussion those types which seem most adequately to illustrate the principles, and no attempt has been made to cover fully the details of all classes of masonry structures. The purpose has been to provide an introduction to the subject, which may later be followed by intensive study in more detailed works upon the various branches. This gives a general view of the subject as a whole, and is the natural method of approach.

The Author has derived much assistance from a number of books which deal more fully with various portions of the subject. These are mentioned at the ends of articles or chapters to which they specially relate. They should be studied by students desiring a more complete presentation of the subject.

Special acknowledgment is also due to Professors A. Lincoln Hyde and Guy D. Newton of the University of Missouri for reading and criticising portions of the manuscript and for assistance in preparing the illustrations.

F. P. SPALDING.

COLUMBIA, MISSOURI,  
September, 1920.

436264





# CONTENTS

---

## CHAPTER I

### DEVELOPMENT OF MASONRY CONSTRUCTION

|   | PAGE |
|---|------|
| ART. 1.—INTRODUCTION.....                       | 1    |
| 1. Definition; 2. Uses of Masonry.              |      |
| ART. 2.—EARLY HISTORY.....                      | 3    |
| 3. Ancient Masonry; 4. Roman and Medieval.      |      |
| ART. 3.—RECENT DEVELOPMENTS.....                | 5    |
| 5. The Cement Industry; 6. Reinforced Concrete. |      |

## CHAPTER II

### CEMENTING MATERIALS

|  |    |
|--|----|
| ART. 4.—LIME.....  | 9  |
| 7. Classification; 8. Common Lime; 9. Hydraulic Lime; 10. Hydrated Lime; 11. Specifications.   |    |
| ART. 5.—HYDRAULIC CEMENT.....  | 16 |
| 12. Setting and Hardening; 13. Portland; 14. Natural; 15. Puzzolan; 16. Sand Cement; 17. Soundness; 18. Chemistry of Cement.                       |    |
| ART. 6.—SPECIFICATIONS AND TESTS FOR CEMENT.....   | 26 |
| 19. Specifications; 20. Purpose of Tests; 21. Compressive Strength; 22. Special Tests.   |    |
| ART. 7.—SAND FOR MORTAR.....   | 31 |
| 23. Quality; 24. Tests; 25. Mechanical Analysis; 26. Voids; 27. Specific Gravity; 28. Density; 29. Strength Test; 30. Washing; 31. Specifications. |    |
| ART. 8.—CEMENT MORTAR.....   | 39 |
| 32. Proportioning; 33. Mixing; 34. Yield; 35. Mixtures of Lime with Cement; 36. Strength.  |    |
| ART. 9.—GYPSUM PLASTERS.....   | 48 |
| 37. Classification; 38. Properties and Uses.   |    |

## CHAPTER III

## STONE MASONRY

|   | PAGE |
|---|------|
| ART. 10.—BUILDING STONE.....  | 51   |
| 39. Qualities; 40. Classification; 41. Strength; 42. Durability.                            |      |
| ART. 11.—STONE CUTTING.....   | 62   |
| 43. Tools; 44. Methods of Finishing; 45. Machinery.   |      |
| ART. 12.—WALLS OF STONE MASONRY.....  | 70   |
| 46. Classification; 47. Parts of Wall; 48. Stonework; 49. Trimmings;<br>50. Specifications. |      |
| ART. 13.—STRENGTH OF STONE MASONRY.....   | 78   |
| 51. Compressive; 52. Capstones and Templets; 53. Lintels and<br>Corbels.                    |      |
| ART. 14.—MEASUREMENT AND COST.....  | 82   |
| 54. Measurements; 55. Cost.   |      |

## CHAPTER IV

## BRICK AND BLOCK MASONRY

|   |     |
|---|-----|
| ART. 15.—BUILDING BRICKS.....   | 85  |
| 56. Clay and Shale; 57. Sand Lime; 58. Cement; 59. Tests.                             |     |
| ART. 16.—BRICK MASONRY.....   | 93  |
| 60. Joints; 61. Bond; 62. Strength; 63. Efflorescence; 64. Measure-<br>ment and Cost. |     |
| ART. 17.—TERRA COTTA CONSTRUCTION.....  | 102 |
| 65. Structural Tiling; 66. Block Construction; 67. Architectural<br>Terra Cotta.      |     |
| ART. 18.—GYPSUM AND CEMENT CONCRETE BLOCKS.....                                       | 107 |
| 68. Gypsum Wall Blocks; 69. Roof and Floor Blocks; 70. Hollow<br>Concrete Blocks.     |     |

## CHAPTER V

## PLAIN CONCRETE

|  |     |
|--|-----|
| ART. 19.—AGGREGATES FOR CONCRETE.....  | 110 |
| 71. Materials; 72. Tests for Coarse Aggregates.  |     |
| ART. 20.—PROPORTIONING CONCRETE.....   | 116 |
| 73. Arbitrary; 74. Voids; 75. Analysis Curves; 76. Trial; 77. Fine-<br>ness Modulus and Surface Area; 78. Yield. |     |

|   | PAGE |
|---|------|
| ART. 21.—MIXING CONCRETE.....   | 125  |
| 79. Preparing Materials; 80. Hand Mixing; 81. Machine.  |      |
| ART. 22.—PLACING CONCRETE.....  | 129  |
| 82. Transporting; 83. Depositing; 84. Freezing; 85. Contraction Joints; 86. Finishing Surfaces. |      |
| ART. 23.—WATERTIGHT CONCRETE.....   | 136  |
| 87. Permeability; 88. Integral Waterproofing; 89. Exterior Coatings.                            |      |
| ART. 24.—DURABILITY OF CONCRETE.....  | 140  |
| 90. Destructive Agencies; 91. Sea Water; 92. Alkalies; 93. Fire Resistance.                     |      |
| ART. 25.—STRENGTH OF PLAIN CONCRETE.....  | 144  |
| 94. Compression; 95. Tests; 96. Tension and Transverse.   |      |
| ART. 26.—COST OF CONCRETE WORK.....   | 149  |
| 97. Materials; 98. Labor; 99. Total Costs.  |      |

CHAPTER VI

REINFORCED CONCRETE

|  |     |
|--|-----|
| ART. 27.—GENERAL PRINCIPLES.....   | 153 |
| 100. Object of Reinforcement; 101. Bond Strength; 102. Reinforcing Steel; 103. Modulus of Elasticity; 104. Reinforced Concrete in Tension. |     |
| ART. 28.—RECTANGULAR BEAMS WITH TENSION REINFORCEMENT.....   | 158 |
| 105. Flexure Formulas; 106. Tables; 107. Shear; 108. Diagonal Tension; 109. Bond; 110. Design.   |     |
| ART. 29.—T-BEAMS WITH TENSION REINFORCEMENT.....   | 178 |
| 111. Flexure Formulas; 112. Shear and Bond; 113. Diagrams.   |     |
| ART. 30.—BEAMS REINFORCED FOR COMPRESSION.....   | 186 |
| 114. Flexure Formulas; 115. Tables and Examples.   |     |
| ART. 31.—SLAB AND BEAM DESIGN.....   | 194 |
| 116. Bending Moments and Shears; 117. Loadings; 118. Design.   |     |
| ART. 32.—CONCRETE COLUMNS.....   | 206 |
| 119. Plain Concrete Columns; 120. Longitudinal Reinforcement; 121. Hooped Reinforcement; 122. Eccentric Loads.                             |     |

CHAPTER VII

RETAINING WALLS

|  |     |
|--|-----|
| ART. 33.—PRESSURE OF EARTH AGAINST A WALL.....           | 214 |
| 123. Theories; 124. Computations; 125. Graphical Method. |     |

|   | PAGE |
|---|------|
| ART. 34.—SOLID MASONRY WALLS.....                                     | 223  |
| 126. Stability; 127. Empirical Design; 128. Design Using Formulas.    |      |
| ART. 35.—REINFORCED CONCRETE WALLS.....                               | 229  |
| 129. Types; 130. Cantilever Walls; 131. Counterforted Walls.          |      |
| ART. 36.—CONSTRUCTION OF RETAINING WALLS.....                         | 244  |
| 132. Foundations; 133. Drainage and Back-filling; 134. Gravity Walls. |      |

## CHAPTER VIII

## MASONRY DAMS

|  |     |
|--|-----|
| ART. 37.—GRAVITY DAMS.....   | 247 |
| 135. Stability; 136. Graphical Analysis; 137. Design of Profile; 138. Diagonal Compressions; 139. Horizontal Tension; 140. Uplift. |     |
| ART. 38.—DAMS CURVED IN PLAN.....  | 258 |
| 141. Curved Gravity Dams; 142. Arch Dams; 143. Multiple Arch Dams.   |     |
| ART. 39.—REINFORCED CONCRETE DAMS.....   | 266 |
| 144. Arch Dams; 145. Flat Slab and Buttress Dams.  |     |
| ART. 40.—CONSTRUCTION OF MASONRY DAMS.....   | 268 |
| 146. Foundations; 147. Masonry; 148. Overflow Dams.  |     |

## CHAPTER IX

## SLAB AND GIRDER BRIDGES

|  |     |
|--|-----|
| ART. 41.—LOADINGS FOR SHORT BRIDGES.....   | 271 |
| 149. Highway Bridges; 150. Distribution of Concentrated Loads; 151. Railway Bridges. |     |
| ART. 42.—DESIGN OF BEAM BRIDGES.....   | 273 |
| 152. Slab Bridges; 153. T-Beam Bridges; 154. Girder Bridges.                         |     |

## CHAPTER X

## MASONRY ARCHES

|  |     |
|--|-----|
| ART. 43.—VOUSSOIR ARCHES.....                                | 282 |
| 155. Definitions; 156. Stability.                            |     |
| ART. 44.—LOADS FOR MASONRY ARCHES.....                       | 286 |
| 157. Highway Bridges; 158. Railway Bridges; 159. Dead Loads. |     |



|  | PAGE |
|--|------|
| ART. 45.—DESIGN OF VOUSSOIR ARCHES.....  | 289  |
| 160. Methods; 161. Thickness of Arch; 162. Stability.  |      |
| ART. 46.—THE ELASTIC ARCH.....   | 295  |
| 163. Analysis; 164. Temperature; 165. Direct Thrust.   |      |
| ART. 47.—DESIGN OF REINFORCED CONCRETE ARCH.....   | 300  |
| 166. Selection of Dimensions; 167. Division of Arch Ring; 168. Analysis; 169. Stresses.  |      |
| ART. 48.—TYPE OF CONCRETE ARCHES.....  | 309  |
| 170. Arrangement of Spandrels; 171. Methods of Reinforcement; 172. Hinged Arches; 173. Unsymmetrical Arches; 174. Elastic Piers. |      |
| ART. 49.—OTHER METHODS OF ANALYSIS.....  | 314  |
| 175. Influence Lines. 176. Arbitrary Divisions.  |      |

## CHAPTER XI

## CULVERTS AND CONDUITS

|   |     |
|---|-----|
| ART. 50.—CULVERTS.....  | 321 |
| 177. Types; 178. Area of Waterway; 179. Pipe Culverts; 180. Box Culverts; 181. Arch Culverts. |     |
| ART. 51.—CONDUITS.....  | 332 |
| 182. Types; 183. Gravity Conduits; 184. Pressure.   |     |

## CHAPTER XII

## FOUNDATIONS

|  |     |
|--|-----|
| ART. 52.—FOUNDATION MATERIALS.....   | 342 |
| 185. Examination of Soil; 186. Bearing Capacity; 187. Tests of Bearing Capacity.                                       |     |
| ART. 53.—SPREAD FOUNDATIONS.....   | 347 |
| 188. Distribution of Loads; 189. Masonry Footings; 190. Grillage; 191. Reinforced Concrete.                            |     |
| ART. 54.—PILE FOUNDATIONS.....   | 358 |
| 192. Classification; 193. Pile Drivers; 194. Timber Piles; 195. Bearing Power; 196. Concrete Piles; 197. Sheet piling. |     |
| ART. 55.—COFFERDAMS.....   | 373 |
| 198. Types; 199. Sheet Pile; 200. Crib.  |     |
| ART. 56.—BOX AND OPEN CAISSONS.....  | 376 |
| 201. Box Caissons; 202. Types of Open Caissons; 203. Single-wall Timber; 204. Cylinder; 205. Dredging through Wells.   |     |

|  | PAGE |
|--|------|
| ART. 57.—PNEUMATIC CAISSONS.....   | 387  |
| 206. Compressed Air; 207. Construction; 208. Sinking; 209. Physiological Effect.           |      |
| ART. 58.—BRIDGE PIERS AND ABUTMENTS.....   | 393  |
| 210. Locations and Dimensions; 211. Stability; 212. Construction; 213. Types of Abutments. |      |

# MASONRY STRUCTURES

---

## CHAPTER I

### DEVELOPMENT OF MASONRY CONSTRUCTION

#### ART. 1. INTRODUCTION

**1. Definition.**—The term *masonry* in its original significance means “a construction of dressed or fitted stones and mortar.” It is thus properly limited to stone masonry. Custom has, however, extended the use of the term to cover any construction composed of pieces of inorganic non-metallic material fitted together into a monolithic block. This includes all structural work in stone, brick, and tile, as well as concrete construction.

The word brick was formerly used to designate a small block of burned clay. Similar blocks of other materials have recently come into use, and we now have several kinds of bricks; as clay brick, sand-lime brick, cement brick, etc. Glazed and other ornamental and surfacing tiles are commonly employed, while hollow tiles of various kinds are rapidly coming into use. All construction formed of bricks or tiles cemented together may be classed as *brick masonry*.

The term *stone masonry* is used to designate any work in which stones are fitted and cemented together so as to form a structure. Stone masonry is further subdivided into rubble masonry, squared-stone masonry, and ashlar or cut-stone masonry.

Concrete is ordinarily formed by mixing broken stone or gravel with cement mortar to a mobile condition and placing it in forms in the position in which it is to be used. It is then left to harden and forms a monolithic block.

Ordinary concrete cannot be economically employed where tensile stresses are developed in the structure on account of the low tensile resistance of the concrete. It is therefore common, when it is desired to use concrete in such situations, to embed steel rods in the con-

crete to take the tensile stresses, leaving the concrete to carry compression only. This construction is known as *reinforced concrete*.

**2. Uses of Masonry.**—Masonry in some form is now used in nearly all kinds of engineering and architectural construction. The selection of the type of masonry to be used in any particular structure is ordinarily largely a matter of cost, the latter factor depending upon the suitability of the construction to the use to which it is to be put, and the availability and costs of the necessary materials and labor. These factors are subject to local variation and need to be considered in each instance.

Brick masonry is largely used in the construction of buildings, being usually cheaper than stone, and when of good quality showing both strength and durability. Very pleasing architectural effects are readily obtained by proper selection and arrangement of materials in brickwork. Brick masonry is frequently used in the construction of large sewers and in the arch ring of small arched bridges, and is readily adapted to such uses, but is gradually giving way to concrete.

Hollow-tile construction is being quite commonly applied in building operations, and is replacing ordinary brickwork in many instances. It is sometimes faced with brick in exterior walls, and is used for partitions and in solid floor construction on account of its lightness and low cost.

Stone masonry is largely used in architectural construction, where the appearance and permanence of the structure are of special importance. It is almost universally employed in monumental construction, being at once the most durable material known to man and the one capable of producing the most imposing and most beautiful effect.

Many engineering structures such as retaining walls, bridge piers, and abutments and arch bridges are often constructed of stone masonry, or are faced with stone. Concrete is, however, gradually replacing stone masonry for such work on account of lower cost and facility of construction, except where facing of stone is used for appearance or durability.

Concrete is almost universally employed in foundations, having replaced stone masonry for this purpose. In the construction of tunnels, subways, and other underground work, it is usually the cheapest and most convenient material. In heavy masonry, such as retaining walls, dams, piers, and abutments, concrete is commonly used, alone or with a facing of stone masonry.

The use of reinforcement makes it possible to apply concrete in many types of construction to which masonry has heretofore been



inapplicable. For short-span bridges reinforced concrete is rapidly replacing wood and steel, and, on account of its durability, is a much more economical material for such use. Reinforced concrete is extensively used in fireproof building construction for floors, beams, and columns, and is frequently used in connection with hollow tile for this purpose. It is sometimes used for the walls of buildings but is apt to be more expensive than brick, on account of the forms necessary in such work.

## ART. 2. EARLY HISTORY

**3. Ancient Masonry.**—The art of masonry construction dates from the earliest records of authentic history. The most fruitful source from which to obtain a knowledge of the history of the more ancient peoples is in a study of the remains of their masonry structures.

The earliest important constructions of which we have any remains are probably those of Chaldea and Assyria, with which the great constructions of Egypt may be classed. The dates of few of them are known with accuracy. The earliest of the Chaldean remains are supposed to date from about 2500 B.C. Alongside of these are the remains of the second Babylonian Empire, founded about 600 B.C. Stone and timber were lacking in Chaldea, and hence the natural development of their primitive construction was toward the use of brick. In the earlier and more crude structures, sun-dried brick of rough form were used; later, hard-burned bricks were employed. In some of the early buildings both classes were used, the burned bricks being employed as facing to protect the sun-dried from the weather.

The burned bricks of the earliest times are still found to be sound and hard, and many of the sun-dried still keep their shapes. These bricks were of square, flat form, the burned ones varying from 11 to 13 inches square and  $2\frac{1}{2}$  to 3 inches thick; the sun-dried were somewhat larger.

According to Professor Rawlinson, the cementing material in some of the early Chaldean structures was either a coarse clay, sometimes mixed with straw, or a bitumen of good quality which still unites the bricks so firmly that they can with difficulty be separated.

In the later Babylonian construction the character of the materials shows improvement, and elaborate ornamentation is introduced. Ornamentation was accomplished by enameling and

carving the bricks and by the use of colors. Ordinary lime mortar was used.

Assyria, unlike Chaldea, had plenty of stone. The type of construction used by the Assyrians, however, was probably derived from that of the Chaldeans. Brick was the principal material employed, although frequently stone was used to face the brick walls, and sculptures were freely used. The great halls of their palaces were ornamented with sculptures; the entire walls in some cases to a height of 10 or 12 feet were covered with figures in relief, representing scenes from life, and usually commemorating the greatness of the monarch for whom they were erected.

The arch was used by the Assyrians to a limited extent for narrow openings, the arches being of brick, which were made narrower at one end than the other, in order to fit in the arch.

The art of construction in Egypt was much more advanced than in Assyria and Babylonia and was probably of an earlier date. The ancient Egyptians were very skillful in working stone. Their temples were built of large blocks of stone, well squared, and laid so that the joints are scarcely visible. They quarried granite and transported large blocks for long distances. They also cut and polished granite.

The great pyramid has a base of 764 feet square and is approximately 486 feet high, and is built in courses, of great blocks of limestone, from 2 to 5 feet thick and as much as 30 feet in length. The early Egyptian masonry is remarkable both on account of the great size of the materials and the exactness with which they are fitted together, no mortar being employed.

In Greece and Italy remains are found of Cyclopean masonry built of stones of large size and carefully adjusted joints. The walls of Mycenæ were built of irregular blocks of great size, the spaces being filled with smaller stones.

*Greek Masonry.*—The masonry of the Greeks was arranged in courses and the joints carefully fitted and equal to the best Egyptian workmanship. The carving of artistic forms was here for the first time developed to a high degree of excellence.

The Egyptians had used the system of the column and entablature in their temples. The Greeks introduced the pediment, and improved the artistic design of the buildings, bringing the proportioning and ornamentation of such structures to a most wonderful perfection.

**4. Roman and Medieval Construction.**—In the system of construction developed by the Romans the walls were built of coarse

concrete or rough cemented rubble, and were usually faced with brick or marble. Sometimes, in less important construction, small blocks of tufa, set irregularly, formed the surface of the walls, which were stuccoed on their interior surfaces.

The art of building was greatly developed during the Roman period. The introduction of the arch changed the whole system of construction. In the Romanesque architecture, the circular arch was the principal feature, the structures consisting mainly of heavy walls supporting semicircular arched roofs. Roman arches were constructed of cut stone, brick, or concrete.

The introduction of the pointed arch, and later of the use of arched ribs with piers and buttresses to transmit the loads to the foundations, marks another advance in the art of construction. This made possible a disposition of the materials of the structures to better advantage, and led to more economical construction.

During medieval times the use of stone masonry was brought to a high state of perfection. Random ashlar or rubble was commonly used in buildings in preference to coursed ashlar. Beautiful and imposing effects were attained by the use of materials of rather small size, and great skill was developed in the cutting of ornamental forms.

The Romans used lime mortar in their ordinary construction. They also discovered that if certain materials of volcanic origin were pulverized and mixed with lime, the resulting mortar possessed the property of hardening under water. The mortar used by the Romans in their aqueducts and other hydraulic works was made from this material, obtained from near the foot of Vesuvius. Similar materials were later found and used in Germany and France.

### ART. 3. RECENT DEVELOPMENTS

**5. The Cement Industry.**—The discovery by the Romans of the hydraulic properties of volcanic lava, and the location of other materials possessing the same properties, made possible the construction of subaqueous masonry work. No considerable progress, however, was made in such work.

About the middle of the eighteenth century Smeaton, a noted English engineer, discovered that lime made from certain limestones containing clay possessed hydraulic properties. This discovery opened new possibilities in under-water work, and these hydraulic limes were used to a limited extent during the next half century.

In 1796 James Parker, an Englishman, burned limestone con-



taining a larger proportion of clay and ground the product. He thus produced the first natural cement, which he called Roman cement. This process was patented, and the manufacture of natural cement resulted.

In 1818 Canvas White, an engineer of the Erie Canal, located rock suitable for making natural cement in Madison County, New York, and the first cement produced in the United States was made in the same year. Five years later the manufacture of natural cement was begun at Rosendale, New York. The production of cement in this region extended, and cement was thus provided for most of the hydraulic construction in this country for a considerable period. Later, as the development of the country proceeded, and demands for cement increased, deposits of cement rock were found at many other places. Natural cement plants were established along the James River in Virginia; in the Lehigh Valley, in Pennsylvania; at Louisville, Kentucky; Utica, Illinois; Milwaukee, Wisconsin, and a number of other localities.

In 1824 Joseph Aspdin, of Leeds, England, discovered that by burning a mixture of slaked lime and clay at high temperature, hydraulic cement was produced. Aspdin named this material *Portland Cement*, on account of its resemblance to Portland stone, then largely used in England. In 1845 the manufacture of Portland cement was begun on a commercial scale by J. B. White & Sons, in Kent.

During the period between 1830 and 1850 Vicat, in France, made a number of studies which were of great value in extending knowledge of the new material. Plants were soon established in France and Germany for the manufacture of Portland cement, and the industry became an important one throughout Europe. During the next few years, 1865 to 1880, John Grant made a series of investigations of the properties of Portland cement and methods of using it in mortars and concrete. His papers before the Institution of Civil Engineers had a marked influence in shaping the methods of use of cement.

From 1880 to 1900 the Portland cement industry developed rapidly in Europe, and numerous studies were made concerning the composition and properties of the material. LeChatelier, Alexandre, Candlot, and Feret, in France, Tetmajer in Switzerland, Michaelis and Bohme in Germany, Faija in England, and a number of others, investigated all phases of the subject, greatly improving the quality of the cement and showing methods of employing it in construction to secure the best results.



In 1875 Mr. D. O. Saylor began the manufacture of cement at Coplay, Pennsylvania. From this beginning, the American Portland cement industry has developed. Great improvements in methods of manufacture and in the control of the character of the product have been made in this country. The studies of Newberry, Richardson, and others have contributed to definite knowledge of the proper composition of the material, while committees of the National Engineering Societies and many independent investigators have perfected methods of testing cement and of using it in construction.

This industry has now reached immense proportions in the United States, and the use of Portland cement has extended in all directions, modifying largely the types and methods of construction used in all classes of structures.

**6. Reinforced Concrete.**—In the early use of concrete, it was commonly employed as a filler in heavy construction, and was not possessed of great strength. Walls of concrete were usually protected by facings of stone or brick masonry. In recent years, however, the availability of cementing materials of high grade has made possible the use of concrete in many classes of construction for which stone or brick masonry was formerly employed. The facility with which concrete may be applied to many uses makes it highly desirable material, and since the introduction of Portland cement its use has rapidly increased. This use has been further extended in the past few years by the development of reinforced concrete construction. In 1850 Lambot, in France, constructed a boat of reinforced concrete, and in 1855 patented his invention in England. François Coignet, in 1861, applied reinforced concrete to the construction of beams, arches, pipes, etc.

In 1861 Joseph Monier, a gardener of Paris, constructed tubs and small water tanks of concrete in which a wire frame was imbedded. In 1867 Monier patented his reinforcement, which consisted of a mesh formed of wires or rods placed at right angles to each other. He also exhibited some work at the Paris Exposition in the same year. Nothing came of this invention for a number of years, but in 1887 Wayss and Bauschinger published, in Germany, the results of an investigation showing the value of the Monier system, and giving formulas for use in design.

The next few years saw considerable development of this type of construction in Austria, and Melan, an Austrian engineer, invented a system of reinforcement for arches in which I-beams were bent to the form of the arch and enclosed in concrete. Hennebique,

in France, began making reinforced concrete slabs about 1880, and patented his system of slab reinforcement in 1892.

The first use of reinforced concrete in the United States seems to have been by Ernest L. Ransome, in 1874. The next year W. E. Ward constructed a building in New York, in which reinforced concrete walls, roof, and floor beams were used. In 1877 H. P. Jackson used reinforced concrete in building construction in San Francisco. About 1884 Ransome began applying reinforced concrete to important work in California, and in that year took out a patent for the first deformed bar.

In 1894 the Melan system of arch-bridge construction was introduced into the United States by Mr. Fr. von Emperger, who built the first important arch bridges. At about the same time Mr. Edwin Thacher began the construction of arch bridges using bar reinforcement.

During the period from 1890 to 1900 the use of reinforced concrete steadily increased, while the applications of plain concrete had been extending rapidly, as the increasing supply of cement provided material for a better grade of construction.

Since 1900 the use of reinforced concrete has rapidly increased. The use of massive slab construction for railroad bridges was introduced by the C. B. & Q. Railroad at Chicago. Fireproof building construction of concrete has become common, and concrete has become the standard material for short-span highway bridges. Many investigations have been made concerning the properties of the materials and the strengths of various structural forms; the work of Considère, in France, and of Talbot at the University of Illinois, being specially notable. Principles for rational design have been established and recognized standards of practice are rapidly forming.

## CHAPTER II

### CEMENTING MATERIALS

#### ART. 4. LIME

**7. Classification.**—The cementing materials employed in the construction of masonry and concrete structures include *common lime*, *hydraulic lime*, *Portland cement*, *natural cement*, and *puzzolan*. These materials are formed by the calcination of limestones, or of mixtures of limestones with siliceous or argillaceous materials, and their properties vary with the nature and proportions of the substances combined in them.

*Common Lime.*—When limestone composed of nearly pure carbonate of lime is burned, the resulting clinker, known as *quicklime*, possesses the property of breaking up, or *slaking*, upon being treated with a sufficient quantity of water. The slaking of lime is due to its rapid hydration when in contact with water, and the process is accompanied by a considerable increase in the volume of the mass of lime and by a rise in temperature. If the quantity of water be only sufficient to cause the hydration of the lime, the quicklime is reduced to a dry powder; while if the water be in excess it becomes a paste.

The slaked lime thus formed possesses the further property, when mixed to a paste with water and allowed to stand in the air, of hardening and adhering to any surface with which it may be in contact. This hardening of common limes will take place only when exposed to the air and allowed to become dry.

When lime is nearly pure and its activity very great it is known as *fat lime*.

If the lime have mixed or in combination with it considerable impurities of inert character, which act as an adulteration to lessen the activity of the lime, causing a partial loss of the property of slaking and diminishing its power to harden, it is known as *meager* or *poor lime*.

*Hydraulic Lime.*—When the limestone contains about 10 to 20 per cent of silica or clay mixed with the carbonate of lime, the



material resulting from the burning is known as hydraulic lime. This clinker will slake when treated with water like common lime, but with reduced activity. The slaked lime thus obtained possesses the further property, when mixed with water to a paste, of hardening under water and without contact with the air.

In hydraulic lime the silica and alumina are combined with a portion of the lime, forming compounds which harden under water, while part of the lime is left uncombined. This free lime expands when hydrated by addition of water, causing the material to slake.

*Hydraulic Cement.*—When the proportion of siliceous or argillaceous materials in limestone, or mixed with it, is sufficient to combine with all the lime, leaving no lime in a free state, the product of burning is known as hydraulic cement. This clinker will not slake, but must be reduced to powder by grinding. The cement powder, when mixed with water, has the property of setting and hardening under water, and of adhering firmly to any surface with which it may be in contact.

*Portland Cement* is the name given to hydraulic cement which is formed by burning and grinding an intimate mixture of powdered limestone and argillaceous matter in accurately determined proportions. In making Portland cement, the ingredients are carefully proportioned to secure the complete combination of the lime with the silica and alumina into active material, and it is necessary to reduce the materials to a very fine state and secure uniform incorporation of the ingredients before burning.

*Natural Cements* are made by burning limestones which contain proper proportions of argillaceous materials, and grinding the resulting clinker to powder. Natural cements are less rich in lime than Portland cements, complete combination of the argillaceous materials not being effected. They are burned, like lime, without the pulverization of the raw materials, and require a much lower temperature in burning than Portland cement.

The term *Puzzolan* is commonly applied to a class of materials which, when made into a mortar with fat lime or feebly hydraulic lime, impart to the lime hydraulic properties and cause the mortar to harden under water. It derives its name from Pozzuoli, a city of Italy near the foot of Mount Vesuvius, where its properties were first discovered. It was extensively used by the Romans in their hydraulic constructions, being mixed with slaked lime for the formation of hydraulic mortar. Puzzolan is essentially a silicate of alumina in which the silica exists in a condition to be attacked

readily by caustic alkalies, and hence easily combines with the lime in the mortar.

*Puzzolan Cement* is formed by mixing slaked lime with puzzolan and grinding the mixture to a fine powder. Certain materials of volcanic origin are frequently used for this purpose in Europe, while considerable quantities of cement of this class have been made by the use of blast furnace slag, both in Europe and the United States.

**8. Common Lime.**—Common lime is such as does not possess hydraulic properties. It is divided into fat or rich lime and meager lime, according to the quantity of impurities of an inert character it may contain. When made into paste and left in air it slowly hardens. The process of hardening consists in the gradual formation of carbonate of lime through the absorption of carbonic acid from the air, accompanied by the crystallization of the mass of hydrated lime as it gradually dries out. In common lime the final hardening takes place very slowly, working inward from the surface, as it is dependent upon contact of the mortar with the air. When the lime is nearly pure the resulting carbonate is likely to be somewhat soluble, and consequently to be injured by exposure. Nearly all limes, however, contain small amounts of silica and alumina, and these ingredients, even when in quantities too small to render the lime hydraulic, impart a certain power to set, causing the hardening to take place with greater rapidity and without entire dependence upon contact with air. It also renders the material less soluble and more durable in exposed situations.

Nearly pure limes, consisting mainly of calcium oxide, are very caustic and become hydrated very rapidly when brought into contact with water. This hydration, or slaking, produces a rise in temperature and increase in volume, which vary in amount according to the purity of the lime, the volume being doubled or tripled for good fat lime. When the lime is derived from a magnesian limestone, it may contain a considerable proportion of magnesia mixed with the lime. Limes containing more than about 15 per cent of magnesia are usually called magnesian limes. The presence of magnesia has the effect of rendering the lime less active, causing it to expand less upon slaking. The magnesian limes harden more slowly, but usually gain a higher ultimate strength than the high-calcium limes.

The common method of slaking lime consists in covering the quicklime with water, using two or three times the volume of the lime. This method is known as drowning. The lime is usually

spread out in a layer perhaps 6 or 8 inches thick, in a mixing box, the water poured over it and allowed to stand. Sufficient time must be allowed for all of the lumps to be reduced. When the lime contains much foreign matter, the operation frequently requires several days. Too great quantity of water is to be avoided, the amount being such as will reduce the lime after slaking to a thick pasty condition. All the water should be added at once, as the addition of water after the hydration is in progress causes a lowering of temperature and checks the slaking. For the same reason, the lime should be covered after adding water, and not stirred or disturbed until the slaking is completed. The covering is often effected by spreading a layer of sand over the lime, the sand being afterward used to mix with it in making mortar.

A second method of slaking is sometimes employed having for its object the reduction of the slaked lime to powder, and known as slaking by immersion. This is accomplished in two ways. By the first method, the lime is suspended in water in baskets for a brief period to permit the absorption of the necessary water, after which it is removed and covered until slaking takes place and the lime falls to powder. By the second method, sprinkling is substituted for immersion, the lime being placed in heaps and sprinkled with the necessary quantity of water, then covered with sand and allowed to stand.

Lime is commonly sold as quicklime, and should be in lumps and not air slaked. When it is old and has been exposed to the air it is likely to have absorbed both moisture and carbonic acid, thus becoming less active, the portion combined with carbonic acid being inert. A simple test of the quality of quicklime is to immerse a lump for a minute, then place in a dish and observe whether it swells, cracks, and disintegrates, with a rise of temperature.

Slaking some days in advance of use is desirable in order to insure the complete reduction of the lime, and it is quite common to slake lime several weeks before it is to be used.

Common lime is ordinarily used in construction as a mortar, mixed with sand. The quantity of lime in the mortar should be just sufficient to fill the voids in the sand, without leaving any part formed entirely of lime. Mortar of rich lime shrinks in hardening, while masses composed entirely of lime on the interior are likely to remain soft, so that an excess of lime may be an element of weakness. If too little lime be used the mortar may be porous and weak. The proportions ordinarily required are between one part lime to two parts sand, and one part lime to three parts sand.



In mixing lime mortar, sand is spread over the lime paste and worked into it with a shovel or hoe. The proper proportions of sand and lime may be judged by observing how the mortar works. If too much sand be used it will be brittle, or "short"; while too much paste will cause it to stick and cake so that it will not flow from the trowel.

Mortar of common lime should not be employed in heavy masonry or in damp situations. Where the mass of masonry is large, the lime mortar will become hardened with great difficulty, and after a long time. The penetration of the final induration due to the absorption of carbonic acid is very slow. The observations of M. Vicat showed that carbonization extended only a few millimeters the first year and afterward more slowly. The induration of the lime along the surfaces of contact with a harder material is usually more rapid than in the interior of the mass of lime, and the strength of adhesion to stone or brick is often greater than that of cohesion between the particles of mortar.

**9. Hydraulic Lime.**—Hydraulic lime is obtained by burning limestone containing silica and alumina in sufficient quantities to impart the ability to harden under water. The hydraulic elements are present in such quantities that they combine with a portion of the lime, forming silicates and aluminates of lime, leaving the remainder as free lime in an uncombined state.

The hydraulic activity of a lime or cement, that is, its ability to harden under water, depends primarily upon the relative proportions of the hydraulic ingredients and of lime. Silica and alumina are considered to be the effective hydraulic ingredients, and it is common to designate the ratio of the sum of the weights of silica and alumina to that of lime in the material its *hydraulic index*. The hydraulic index gives, therefore, within certain limits, a measure of the hydraulicity of the various classes of limes. It is to be remembered, however, that there are other factors to be considered in judging of the action of lime than this simple proportion. The other ingredients may by their combinations withdraw portions of the active elements so as to modify the effective ratio between them, while the activity of the lime depends largely upon the state of combination in which the active elements exist. This is not shown by analysis, and may be greatly modified by the manipulation given the material during manufacture.

Limes with hydraulic index less than 10/100 possess little if any hydraulic properties, and are known as common limes. When the hydraulic index is between 10/100 and 20/100 the lime is feebly

hydraulic, and may require from twelve to twenty days to set under water. Hydraulic lime proper includes that of index from about 20/100 to 40/100. These may harden in from two to eight or ten days.

The quantity of free lime in the material is dependent upon the degree of burning, as well as upon the amount of lime contained by the stone. If the stone be underburned, the combination of the hydraulic elements with the lime is not complete, and more of the lime remains in a free state. For this reason, a stone of high hydraulic index may, when underburned, yield a lime, but burned at a high temperature becomes unslakable. The best limes are usually those which can be burned at a high temperature to complete the chemical combinations. It is necessary that sufficient free lime be present to cause the lime to slake properly, but it is also desirable that the quantity of uncombined lime be as small as possible, as the setting properties are due to the silicates and aluminates, while the hydrated lime remains inert during the initial hardening of the mortar.

According to Professor LeChatelier, limestone for hydraulic lime should contain but little alumina, as the aluminates are hydrated during the slaking of the lime, while the silicates are not affected, the heat of the slaking preventing their hydration.

The following is given as an average analysis of the best French hydraulic lime:

|                     |     |
|---------------------|-----|
| Silica.....         | 22  |
| Alumina.....        | 2   |
| Oxide of iron.....  | 1   |
| Lime.....           | 63  |
| Magnesia.....       | 1.5 |
| Sulphuric acid..... | 0.5 |
| Water.....          | 10  |
|                     | 100 |

It is important that the slaking be very thorough, as the presence of unhydrated free lime in the mortar while hardening is an element of danger to the work. Any lime becoming hydrated after the setting of the mortar may, by its swelling, cause distortion and perhaps disintegration of the mortar.

After the lime has been reduced to powder by slaking, it is forced through sieves which permit the passage of all pulverized particles but hold those of appreciable size, including the underburned rock

and the overburned parts which refuse to slake. The residue left from the sifting of hydraulic lime is known as *grappiers*. This material is mainly composed of hard material more rich in silica and alumina than the other portions of the lime. The *grappiers* are frequently ground and sold as cement, and when properly handled may form cement of fairly good quality.

**10. Hydrated Lime.**—When quicklime is slaked with the quantity of water necessary completely to hydrate it, and the resulting material is bolted to remove all unslaked particles, the result is a very fine white powder, commercially known as hydrated lime. This lime is sold on the market in barrels or bags, and it is in convenient form for use. Lime in this form may be kept for considerable periods without deterioration, provided it is protected from contact with moisture.

Hydrated lime ordinarily weighs about 40 pounds per cubic foot, and contains approximately 75 per cent of quicklime. By mixing with about an equal weight of water, it may be reduced to lime paste, or *lime putty*, as it is commonly called in building operations. Lime paste occupies a slightly greater volume than the hydrated lime from which it is prepared.

The use of hydrated lime for mixing with cement mortar in ordinary masonry construction is rapidly increasing. It is also frequently used in small proportions in Portland cement concrete to make the concrete flow more smoothly, and sometimes to decrease the permeability of the mortar. (See Art. 23.)

**11. Specifications for Lime.**—In ordinary building operations lime is commonly employed in the form of quicklime and slaked where used. Usually the quality of the lime has been judged by its activity in slaking and no particular tests are specified. Tests of composition by chemical analysis and of completeness of slaking by washing through sieves are, however, frequently employed.

Hydrated lime is now largely used for mixing with cement mortar and for plastering work, and this use is rapidly extending. The tests employed for hydrated lime include chemical analysis, fineness, and permanence of volume or soundness.

The American Society for Testing Materials has adopted standard specifications giving methods for making these tests. These specifications are given in the Book of Standards of the Society or may be obtained in pamphlet form from the Secretary of the Society. As they are now undergoing revision they are subject to change and will not be given here.



## ART. 5. HYDRAULIC CEMENT

**12. Setting and Hardening of Cement.**—When cement powder is mixed with water to a plastic condition and allowed to stand, it gradually combines into a solid mass, taking the water into combination, and soon becomes firm and hard. This process of combination among the particles of the cement is known as the setting of the cement.

Cements of different character differ very widely in their rate and manner of setting, some occupying but a few minutes in the operation, while others require several hours. Some begin setting immediately and take considerable time to complete the set, while others stand for considerable time with no apparent action and then set very quickly.

The points where the set is said to begin and end are necessarily arbitrarily fixed, and are determined by finding when the mortar will sustain a needle carrying a specified weight. The initial set is supposed to be when the stiffening of the mass has become perceptible; the final set, when the cohesion extends through the mass sufficiently to offer such resistance to any change of form as to cause rupture before deformation can take place.

After the completion of the setting of the cement, the mortar continues to increase in cohesive strength over a considerable period of time, and this subsequent development of strength is called the *hardening* of the cement.

The process of hardening appears to be quite distinct from, and independent of, that of setting. A slow-setting cement is apt, after the first day or two, to gain strength more rapidly than a quick-setting one; but it does not necessarily do so. The ultimate strength of the cement is also quite independent of the rate of setting. A cement imperfectly burned may set more quickly and gain less ultimate strength than the same cement properly burned, but of two cements of different composition the quicker-setting may be the stronger.

There is as wide variation in the rate of hardening of different cements as in the rate of setting; some gain strength rapidly and attain their ultimate strengths in a few weeks, while others harden much more slowly at first and continue to gain in strength for several years. The rate of early hardening gives but little indication of the ultimate action of the cement, as the final strength of the mortar may be the same however rapidly the strength is attained.

The rate at which cement sets seems to depend upon the pres-

ence of certain aluminates of lime, the rapidity of set increasing with the percentage of alumina in the material. The final hardening is attributed mainly to the silicates of lime, which are the important elements in giving strength and durability to the mortar. The formation of these active elements in the cement depends upon the manipulation of the material in manufacture, as well as upon the composition of the raw materials. In an underburned cement, the relative proportions of aluminates to silicates is large and the set is rapid.

*Calcium Sulphate.*—The addition of a small amount of sulphate of lime to cement has the effect of slackening the rate of set. Such addition is frequently made by manufacturers to reduce the activity of fresh cement, by grinding a small amount of gypsum with the cement.

*Effect of Sand.*—Cement is ordinarily employed in mortar formed by mixing it with sand, and the action of the mortar is necessarily largely affected by the nature and quantity of sand used.

When the cement is finely ground and the sand of good quality, a mortar composed of equal parts of each, as a general thing, finally attains a strength as high as, or higher than, that of neat cement. Cements of different characters, however, vary considerably in their power to "take sand" without loss of strength; some of the weaker ones may not be able to take more than half their weight of standard sand, while others can be mixed with considerably more than their own weight without loss of strength at end of six months or one year after mixing. All have a certain limit within which they may be made stronger by an admixture of good sand than they would be if mixed neat.

Clean and sharp sand usually gives higher strength in mortar than that containing admixtures of clay or earth, or that composed of rounded grains, coarse sand usually giving greater strength than that which is very fine. It is often difficult, however, to judge of the quality of sand without experimenting with it. In some cases a small amount of fine clay appears to increase the strength of mortar, while a judicious mixture in the sand of grains of various sizes may be of value in reducing the volume of interstices. Mortar composed of sand and cement usually possesses greater ability to adhere to other surfaces when coarse sand is used than when the sand is fine.

*Effect of Water.*—The quantity of water used in mixing mortar is one of the most important elements; the less the quantity, provided there be sufficient to thoroughly dampen the mass of cement,



the quicker the set. With some Portland cements, changing the quantity of water used in mixing from 20 to 25 per cent of the weight doubles or even triples the time required for the mortar to set.

When the quantity of water used in mixing is sufficient to reduce the mortar to a soft condition, the hardening as well as the setting becomes slow, and the strength during the early period is less than when a less quantity of water is used. This difference disappears to a considerable extent with time, and the mortar mixed wet may eventually gain as much strength as though mixed with less water.

Cement mortar kept under water hardens more rapidly in the early period than that exposed to the air. Nearly any cement mortar will harden more rapidly and gain greater strength if kept moist during the operation of setting and the first period of hardening than if it be exposed at that time to dry air. Sudden drying out about the time of completing setting causes a considerable loss of strength in cement mortar, and frequently the mortar so treated is filled with drying cracks. This result is usually more marked when the mortar has been mixed quite wet.

*Effect of Temperature.*—The temperature of the water used in mixing and that of the air in which the mortar is placed during setting has an important bearing upon the time required for setting; the higher the temperature, within certain limits, the more rapid the set. Some cements which require several hours to set when mixed with water at temperature of 40° F. will set in a few minutes if the temperature of the water be increased to 80° F. Below a certain inferior limit, ordinarily from 30° to 40° F., the mortar sets with extreme slowness or not at all, while at a certain upper limit, in some cements between 100° and 140° F., a change suddenly occurs from very rapid to very slow rate of set, which then decreases as the temperature increases until the cement ceases to set.

The temperature of the air or water in which the mortar is immersed while hardening has a very important effect upon the gain in strength. Heat accelerates the action, while at temperatures near the freezing-point of water the gain in strength is very slow.

**13. Portland Cement.**—The term Portland cement is used to designate material formed by burning to incipient fusion a finely ground mixture of definite proportions of limestone and argillaceous materials, and grinding the clinker so formed to fine powder. Several classes of materials are used for this purpose. Hard limestone or chalk, consisting of nearly pure carbonate of lime, is frequently employed, mixed with clay or shale to furnish the hydraulic ingredients. In the Lehigh District in Pennsylvania cement rock, con-

sisting of limestone containing silica and alumina in sufficient quantities to make natural cement when burned alone, is mixed with nearly pure limestone to obtain the proper Portland cement composition. In the Michigan district marl and clay excavated in soft and wet condition are used. In a few instances limestone is mixed with blast-furnace slag for the production of Portland cement. This is quite distinct from the manufacture of slag cement (so called) in which the materials are not burned together.

To make good Portland cement it is always necessary that the ingredients be very carefully proportioned and that the mixture be very homogeneous. This requires the pulverization of the materials and their uniform incorporation into the mixture before burning.

The burning of Portland cement requires high heat to insure complete combination of the lime with the silica and alumina. In underburned cement, a part of the lime may be left as caustic lime, uncombined with the clay. This is apt to produce unsound cement, which may swell and crack after being used.

The action of Portland cement seems to depend upon the formation, during burning, of certain silicates and aluminates of lime which constitute the active elements of the cement, the other ingredients being considered impurities. The ideal cement would be that in which the proportion of lime is just sufficient to combine with all the silica and alumina in the formation of active material. If there be a surplus of clay beyond this point, it forms inert material. Any surplus of lime remains in the cement as free lime and constitutes one of the chief dangers in the use of cement, as, although it may not prevent the proper action of the cement when used, it may cause the mortar to swell afterward and become cracked and distorted as the lime slakes.

As perfect homogeneity is not attainable in practice, it is always necessary that the clay be somewhat in excess in order that free lime be not formed. The amount of excess of clay necessary depends upon the thoroughness of the burning and the evenness which may be reached in the mixture of the raw materials.

The normal composition of Portland cement is usually within the following limits:

|                          |      |                |
|--------------------------|------|----------------|
| Silica . . . . .         | 20   | to 25 per cent |
| Alumina . . . . .        | 5    | to 9 per cent  |
| Iron oxide . . . . .     | 2    | to 5 per cent  |
| Lime . . . . .           | 59   | to 65 per cent |
| Magnesia . . . . .       | 0.5  | to 3 per cent  |
| Sulphuric acid . . . . . | 0.25 | to 2 per cent  |

After the cement clinker resulting from the burning is sufficiently cooled, it is put through grinders and reduced to a fine powder. The degree of fineness to which the cement is ground is always very important in its effect upon the strength of mortar made from the cement. The valuable part of the cement is that which is ground extremely fine—to an impalpable powder. The coarse parts are not altogether inert, but are more or less active, depending upon the size of the grains of which they are composed.

Cement when used is commonly mixed with sand and the attainment of strength in sand mortar, rather than paste of neat cement, is of importance. The more finely ground the cement, the greater its resistance when mixed with sand, both in the earlier and later stages of hardening, and also the sooner will it reach its ultimate strength. The effect of fine grinding is much greater when the proportion of sand to cement is large, as the power of the cement to "take sand" without diminution of strength is thereby greatly increased. The coarser particles of the cement may be considered as practically inert material, which acts as sand rather than as cement in the mortar. The ability of the cement to harden and develop strength in sand mortar is thus dependent upon the amount of fine material contained in it.

Portland cement made from materials containing very small percentages of iron oxide are very light in color or white. These cements usually contain high percentages of alumina, and are consequently quick setting. They are lower in strength than normal portlands.

**14. Natural Cement.**—The term *natural cement* is used to designate a large number of widely varying products formed by burning rock without pulverization or the admixture of other materials. These cements contain larger proportions of argillaceous materials, with less lime, than Portland cement, and are burned at a lower temperature.

The term *Roman Cement* is used in Europe to designate a class of quick-setting cements formed by burning, at a comparatively low temperature, limestone containing a high percentage of clay. The proportion of alumina in these materials is large and possibly accounts for the quick set. Materials of this character become inert when the temperature of burning is increased to the point where the chemical reactions would become complete.

A class of materials intermediate between the Roman cements and the Portland cements is called in Europe *Natural Portland Cement*. In composition they are similar to Portland cement, but



contain less lime. They are burned at a higher temperature than Roman cements, and are usually slower setting. Natural cements made in the Lehigh region are of this character. These materials may be made into Portland cement by addition of a limestone consisting of more nearly pure carbonate of lime.

*Magnesian Natural Cements* are formed by burning Magnesian limestones. The composition of these cements varies from that of the Roman cements to that in which the proportion of magnesia is as great as that of lime. The action of cements of this class is somewhat similar to that of the Roman cements. They may be either slow or quick setting, and gain strength rather slowly, reaching a much less ultimate strength than Portland cement. Magnesian cements are but little used in Europe, but in the United States they constitute the larger part of the natural cements in use, and many of them have been found by experience to be very useful and reliable materials.

The rock from which natural cements are made differs greatly in character in the same locality, and in different strata in the same quarry. In some of the mills the nature of the product is regulated by mixing, in proper proportions, the clinker obtained by burning rock from different strata. Each portion of the rock must be burned in such degree as is suited to its composition, and hence, as the material is not pulverized before burning, it must be burned separately and mixed afterward. To produce uniformly good cement, therefore, requires close and careful attention; for this reason there is often considerable difference in the quality of cement made by works in the same locality and from very similar materials.

*Mixed Cements.*—In localities where both Portland and natural cements are made by the same works, mixtures of the lower grades of Portland with natural cements are sometimes made. These are usually sold as natural cements under the name *Improved Cements*. The effect of the mixture is to make the setting slower, and to somewhat increase the strength of the natural cement.

**15. Puzzolan Cement.**—Puzzolan cement is formed by mixing and grinding together definite proportions of slaked lime and puzzolan. In Germany puzzolan cement is made by the use of a natural puzzolan called trass, consisting of a volcanic earth. In the United States cement of this character is made by the use of specially prepared blast-furnace slag. This cement is sometimes called slag cement. Basic slag, containing lime in excess of the silica and with a high alumina content, is used for this purpose. It is made granular by quenching in cooling.

It is very important, in making slag cements, that the slag be ground very fine, and be very intimately mixed with the lime. The lime is slaked and bolted and then ground mechanically with the slag so as to insure thorough incorporation into the mixture. In some of the European plants the slag is finely ground and bolted through fine sieves before being mixed with the lime, but more common practice is to slake and bolt the lime and mix with the granular slag before grinding, or to do the pulverizing of the slag in two stages and make the mixture between the first and second grinding.

Puzzolan cement is usually very finely ground, and is slow in setting. It is sometimes treated with soda to quicken the set. When allowed to harden in dry air, it is likely to shrink and crack. When used for under-water work, mortar of puzzolan cement frequently gives nearly the same strength as good Portland cement. It is essentially a hydraulic material, and it is specially important that it be kept damp during the early period of hardening, in order that the water necessary to proper hardening may not evaporate.

The composition of slag cement usually differs from that of Portland cement in having a less quantity of lime, more silica and alumina and more alumina in proportion to silica.

**16. Sand Cement.**—Sand cement is the name given to material formed by grinding together Portland cement and silica sand to extremely fine powder and a very intimate mixture. It is claimed that a considerable amount of sand may be thus mixed with the cement without materially reducing the strength of mortar made by mixing the resulting cement with the usual proportions of sand. The additional grinding reduces all of the cement to impalpable powder, thus increasing the amount of active material.

Sand cement as ordinarily made contains equal proportions of Portland cement and silica sand. Cement of this character has recently been made in California by grinding volcanic rock, or tufa, with Portland cement. The tufa used is a puzzolan, and it is claimed that it reacts with the lime of the cement. The results of tests indicate that mortar made from this cement is equal in strength to that of the original Portland. Cement of this kind is now being made by the U. S. Reclamation Service in some of the Western States to reduce the cost of concrete work where Portland cement is expensive and difficult to get.

Similar methods are employed in Germany where a puzzolan called trass is used, and in Italy where volcanic lava is ground with the cement. These cements are used for work in sea water to les-



sen the action of the sea salts upon the lime salts of the Portland cement.

Sand cement has frequently been used for the purpose of securing impermeable mortar where waterproof work is needed. It is useful for this purpose on account of its extreme fineness.

**17. Soundness of Cement.**—The permanence of any structure erected by the use of cement is dependent upon the ability of the cement, after the setting and hardening processes are complete, to retain its strength and form unimpaired for an indefinite period. Experiment has shown that mortars made from cement of good quality frequently continue to gain strength and hardness through a period of several years, or at least that there is no material diminution in strength with time; and that changes of temperature, or in the degree of moisture surrounding it, produce no injurious effects upon the material. This durability in use is commonly known as the *permanence of volume or soundness* of the cement.

When mortar which has been immersed in water is transferred to dry air, a slight contraction may take place in volume, together with an increase in strength; while a transfer the other way may produce the opposite result; but no distortion of form or disintegration of the mortar will take place in either case if the cement be of good quality.

Sometimes cement when made into mortar sets and hardens properly, and later, when exposed to the action of the atmosphere or water, becomes distorted and cracked or even entirely disintegrated. If the composition deviates but slightly from the normal, this process of disintegration may not show itself for a considerable time and proceeds very slowly. It thus becomes an element of considerable danger, as it is liable to escape detection in testing the cement.

The presence of small quantities of free lime in cement is doubtless one of the most common causes of disintegration in cement mortar. The lime being distributed through the cement in small particles is hydrated very slowly after the cement has set, causing, through its swelling during slaking, strong expansive forces on the interior of the mortar, and producing an increase of volume, loss of strength, and perhaps final disintegration.

Free magnesia in cement is supposed to act very much like free lime. The action of magnesia, however, is much slower than that of lime, and for this reason is a more serious defect. Specifications for Portland cement frequently limit the amount of magnesia that may be present in the cement.

Most Portland cements probably contain small amounts of the expansive elements, which when in very small quantity act with extreme slowness and perhaps produce no visible effect for several months after the use of the cement; then occurs a decrease of strength, which disappears with time. Cements which gain strength rapidly are quite apt to act in this manner, a depression in the strength curve occurring at from six months to one year after the mortar is made.

Cements for use in sea water should contain very little alumina. Some of the salts in the sea water attack these alumina compounds, causing disintegration of the cement and giving rise to expansive action which cracks and breaks up the work.

The presence of expansive elements in Portland cement is probably due to incomplete burning or lack of uniformity in the incorporation of the ingredients rather than to defective composition.

The fineness of the cement modifies the action of the free lime, as finely divided material will slake more quickly than coarse grains, and the lime is more apt to become hydrated before setting; or, if the cement be exposed before use, the lime in a fine state will sooner become air slaked.

**18. Chemistry of Cement.**—Professor LeChatelier was the first to explain the composition of Portland cement. He studied sections of clinker under the microscope, and examined the properties of the various compounds formed by the principal ingredients. He concluded<sup>1</sup> that the tricalcium silicate,  $3\text{CaO}$ ,  $\text{SiO}_2$ , is the only silicate that is really hydraulic, and that it is the essential active element in cement. In Portland cement he finds it to be the principal component, occurring in cubical crystals. It is formed by combination of silica and lime in presence of fusible compounds formed by alumina and iron.

“The dicalcium silicate,  $2\text{CaO}$ ,  $\text{SiO}_2$ , possesses the singular property of spontaneously pulverizing in the furnace upon cooling. This silicate does not possess hydraulic properties and will not harden under water.

“There are various aluminates of lime, all of which set rapidly in contact with water. The most important is the tricalcium aluminate,  $3\text{CaO}$ ,  $\text{Al}_2\text{O}_3$ .”

Professor LeChatelier gives two limits within which the quantity of lime in Portland cement should always be found. These are, that the proportion of lime should always be greater than that represented by the formula

<sup>1</sup> *Annales des Mines*, September, 1893.

$$\frac{\text{CaO} + \text{MgO}}{\text{SiO}_2 - \text{Al}_2\text{O}_3 - \text{Fe}_2\text{O}_3} = 3,$$

and that it should never exceed that given by the formula,

$$\frac{\text{CaO} + \text{MgO}}{\text{SiO}_2 + \text{Al}_2\text{O}_3 - \text{Fe}_2\text{O}_3} = 3.$$

The symbols in these formulas represent the number of equivalents of the substances present, not the weights.

Messrs S. B. and W. B. Newberry from a study of the compounds of silica and alumina with lime reached the following conclusions:<sup>1</sup>

(1) Lime may be combined with silica in proportion of three molecules to one and still give a product of practically constant volume and good hardening properties, though hardening very slowly. With  $3\frac{1}{2}$  molecules of lime to one of silica the product is not sound and cracks in water.

(2) Lime may be combined with alumina in the proportion of two molecules to one, giving a product which sets quickly but shows good hardening properties. With  $2\frac{1}{2}$  molecules of lime to one of alumina the product is unsound.

Assuming that the tricalcic silicate and the dicalcic aluminate are the most basic compounds which can exist in good cement we arrive at the following formula:

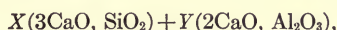

in which  $X$  and  $Y$  are variable quantities depending upon relative proportions of silica and alumina in materials employed.

$3\text{CaO}, \text{SiO}_2$  corresponds to 2.8 parts of lime by weight to 1 of silica, while  $2\text{CaO}, \text{Al}_2\text{O}_3$  corresponds to 1.1 parts of lime to one of alumina.

$$\text{Per cent lime} = \text{Per cent silica} \times 2.8 + \text{Per cent alumina} \times 1.1.$$

Mr. G. A. Rankin, in an extended study of the composition of Portland cement<sup>2</sup> finds the essential constituents to be the tricalcium silicate,  $3\text{CaO}, \text{SiO}_2$ ; the dicalcium silicate,  $2\text{CaO}, \text{SiO}_2$ ; and the tricalcium aluminate,  $3\text{CaO}, \text{Al}_2\text{O}_3$ . He finds that in burning Portland cement, after the carbon dioxide has been driven off, the lime combines with silica and alumina, forming first a fusible aluminate,  $5\text{CaO}, \text{Al}_2\text{O}_3$ , and the dicalcium silicate. At higher temperatures these compounds unite with additional lime, forming the tricalcium aluminate and silicate. When the material is not thoroughly burned, and complete equilibrium is not reached, the clinker will contain free lime,  $\text{CaO}$ , and the aluminate,  $5\text{CaO}, \text{Al}_2\text{O}_3$ . Magnesia and iron oxide have little influence on the final main

<sup>1</sup> Journal Society of Chemical Industry, Nov. 30, 1897.

<sup>2</sup> Journal Industrial and Engineering Chemistry, June, 1915.



constituents of the cement, but act as fluxes and lower the temperature at which the reactions take place.

Too high proportion of lime causes cement to be unsound through the presence of free lime. The same results are caused by underburning or by irregular incorporation of the raw materials into the mixture. As perfect uniformity in the mixture of the ingredients is not attainable in the manufacture of cement, it is necessary that the amount of lime be somewhat less than the theoretic maximum to avoid unsoundness in the cement. The desirable proportion of lime seems to be that which will change the dicalcium silicate to tricalcium silicate as completely as possible without producing unsoundness.

The ratio of silica to the sum of alumina and iron in cement materials is known as the *silica ratio*. It is desirable that the silica ratio be at least 2.5 or possibly 3 in Portland cement.

Very little is definitely known concerning the chemical reactions which take place in the setting and hardening of cement mortars. Studies are in progress which it is hoped may throw light upon the subject and tend to more accurate knowledge of the requirements for such materials.

#### ART. 6. SPECIFICATIONS AND TESTS FOR CEMENT

**19. Standard Specifications.**—The specifications of the American Society for Testing Materials are now commonly recognized as standard and used in the purchase of cement in the United States. These specifications were adopted in 1904 and revised in 1908, 1909, and 1916. In specifications for construction of masonry and concrete it is usual to require that the cement meet the requirements of the American Society for Testing Materials, although in ordinary work it is not common to actually apply all the tests. The tests of chemical analysis and specific gravity are used only when special reasons exist for their application in the character of the work to which the cement is to be applied or doubt as to the material offered.

It is frequently necessary, on important work, to modify the specifications to suit the peculiarities of the particular construction, This is particularly the case in work to be subjected to the action of sea water, or unusual conditions of service.

The general specifications adopted in 1909 were modified in 1916 as to Portland cement only, those for natural cement being left unchanged. The Committee, however, expressed the intention of proceeding with the modification of the requirements for natural

cement as soon as possible, and changes may be expected in these at an early date. The methods of making the tests for Portland are to be also applied to natural cement.

The 1916 specifications make some important changes from those previously used. The No. 100 sieve is dropped from the test for fineness and the requirements somewhat increased for the No. 200 sieve. The Gillmore needles are introduced as an alternate method in the test for rate of setting. Tensile tests of cement paste are dropped and sole dependence placed on the 1 to 3 mortar test, requirements for which are somewhat increased. The normal test for soundness which had previously been the final test is dropped and the steam test is made the standard.

The specifications have been gradually developed through experience with a number of different methods of testing which have been changed from time to time as knowledge of the material has increased and manufacturers have improved the quality of the material they are able to produce. The reliability of the cement on the market has markedly improved within a few years past and the likelihood of finding poor cement and consequently the necessity for tests under ordinary circumstances has greatly diminished. The application of tests where feasible and upon all important work is, however, desirable.

The specifications for Portland cement adopted in 1916 are the result of several years' work of a Joint Committee of the American Society of Civil Engineers, the U. S. Government Engineers, and the American Society for Testing Materials. They are published in the Book of Standards of the Society for Testing Materials, and are also reprinted for distribution to those interested in cement testing by the Portland Cement Association.

**20. Purpose of Standard Tests.**—The tests imposed by the standard specifications are chemical analysis, specific gravity, fineness, normal consistency, time of setting, tensile strength, and soundness. Specifications covering all of these are usually employed for cement to be used in important work. The making of the tests for chemical analysis and specific gravity are often omitted when the cement proves satisfactory upon the other tests.

The *chemical analyses* employed for Portland cement are intended to determine whether the cement has been adulterated with inert material, such as slag or ground limestone, and whether magnesia or sulphuric anhydride are present in too large amounts.

The test for *specific gravity* when used for Portland cement is intended mainly to detect adulteration with materials of lower



specific gravity. It may also aid in determining the true character of the material and whether the cement is well burned. The specific gravity of Portland cement is usually between 3.10 and 3.20, that of a natural cement 2.75 to 3.10, and puzzolan cement 2.7 to 2.9. Good Portland cement may be lowered in specific gravity by long exposure to the air without serious injury to the cement. For this reason, the specifications allow a second test upon an ignited sample of cement failing upon a first test.

The test for *normal consistency* is made to determine the proper quantity of water to be used in the paste or mortar for tests of time of setting or strength. In the preparation of paste or mortar for these tests, variations in the quantity of water used, or in the methods of mixing and molding the specimens, may produce considerable differences in results. A standard method is therefore prescribed.

The *time of setting* is tested for the purpose of determining whether the cement is suitable for a given use, rather than as a measure of the quality of the cement. Testing for time of setting consists in arbitrarily fixing two points in the process of solidification called the initial set and the final set. This is accomplished by noting the penetration of a standard needle carrying a given weight into the mass of cement.

The test for *fineness* is to determine whether the cement is properly ground. Only the extremely fine powder is of value as cement. The coarse parts, while having some cementing value, are practically inert when used in sand mortar.

The test for *tensile strength* of cement pastes and mortars is made for the purpose of demonstrating that the cement contains the active elements necessary to cause it to set and harden properly. Cement is not usually subjected to tensile stresses in use, but the tensile test has commonly been employed because it offers the easiest way to determine strength, and seems to give a satisfactory means of judging the desired qualities.

The proper conduct of any test for strength is a matter requiring care and experience. There are a number of points connected with the conditions and manipulation of the tests which have important effects upon the results. These are—the form of the briquette, the method of mixing and molding, the amount of water used in tempering the mortar, the surroundings in which the mortar is kept during hardening, the rate and manner of applying the stress, the temperatures at which all the operations are performed. In order to secure uniform results, it is essential that the tests be standardized in all these particulars.

*Soundness* is the most important quality of a cement, as it means the power of the cement to resist the disintegrating influences of the atmosphere or water in which it may be placed. Unsoundness in cement may vary greatly in degree, and show itself quite differently in different material. Cement in which unsoundness is very pronounced is apt to become distorted and cracked after a few days, when small cakes are placed in water. Those in which the disintegrating action is slower may not show any change of form, but after weeks or months gradually lose coherence and soften until entirely disintegrated.

The object in the tests is to accelerate the actions which tend to destroy the strength and durability of the cement. As the tests must be made in a short time, it is necessary to handle the cement in such manner as to cause these qualities to show quickly.

*Normal Test.*—The method which has been commonly employed is to make small cakes, or pats, of cement paste about 3 inches in diameter and  $\frac{1}{2}$  inch thick at the center, with thin edges, upon a plate of glass about 4 inches square. These pats are kept twenty-four hours in moist air and then allowed to stand for twenty-eight days in water, or in the air. The pat during this period should show no signs of cracking, checking, distortion, or disintegration. This is known as the normal test, and has been relied upon as the final test for soundness. This test is defective in requiring too much time and also, in some instances, fails to discover defective material in which the action is very slow.

*Accelerated Tests.*—Numerous tests have been proposed for the purpose of hastening the hardening of the cement and causing unsoundness to show more quickly. In most of these tests, heat is employed to accelerate the changes taking place in the cement, and they are known as accelerated tests.

These tests have usually been made by subjecting small pats of the cement to the action of hot water or steam and observing whether cracking or disintegration takes place. Sometimes small bars of cement are used and the increase in length of the bar measured after exposure to the hot water or steam. The expansion of unsound cement should be much greater than that of sound cement. The tensile strengths of briquettes of cement which have been exposed to hot water or steam are sometimes measured and compared with the strengths of similar briquettes kept at normal temperatures. The heat should cause a considerable increase in strength of sound cement.

The *standard steam test* consists in observing the effect of steam

at about 100° C. upon small pats of the cement. This test was recommended by a committee of the American Society of Civil Engineers in 1904. It has since been included in the specifications of the American Society for Testing Materials in conjunction with the normal pat test, which was the deciding test. In the modified specifications for Portland cement adopted in 1916, the normal test is discontinued and the steam test becomes the standard.

The methods for making the standard tests are described in detail, with the specifications, in the Book of Standards of the American Society for Testing Materials, and in the reprint published by the Portland Cement Association.

**21. Tests of Compressive Strength.**—Tests of compressive strength are seldom used in specifications for cement, on account of the greater ease of making the tensile test and the lighter machines that may be employed for the purpose. These tests have frequently been made for purposes of comparison or to determine special qualities of the material. The standard test piece has usually been a 2-inch cube, prepared in the same manner as the tension specimens. This was recommended by a committee of the American Society of Civil Engineers in 1909.

As cement mortar is usually employed in compression, some engineers prefer to use the compression test in their specifications. A new tentative specification with methods of testing was recommended by a committee of the American Society for Testing Materials in 1916. This has not been adopted by the society as a standard, and may be further modified before such adoption. It is probable that such a standard will be adopted, to be used in conjunction with or to replace the tension test. This proposed specification with the method of making the test is given in Volume I of the Transactions of the Society for 1909. Reprints may be had from the Secretary of the Society.

**22. Special Tests.**—The tests ordinarily employed in determining the quality of cement are enumerated in the preceding sections. Other tests are frequently made to determine special qualities or for the purpose of investigating properties of cements and mortars.

*Transverse Strength.*—Tests of the strength of cement mortar under transverse loading are seldom employed as a measure of the quality of the material, but are frequently made with a view to determining the action of the material in service. Propositions have often been made to substitute the transverse for the tensile test in the reception of material. These suggestions have usually been based upon the simplicity of the test and of the apparatus



with which it may be carried out. The specimen usually employed for this purpose is 1 inch by 1 inch and 6 inches long. It is tested by placing upon knife edges 5 inches apart and bringing the load upon the middle section. Professor Durand-Claye, from a large number of comparative tests, found the unit fiber stress under transverse load to average about 1.9 times the unit stress for tension.

*Adhesive Strength.*—The ability of cement mortar to adhere firmly to a surface with which it may be placed in contact is one of its most valuable properties and quite as important as the development of cohesive strength. Tests for adhesive strength are not employed as a measure of quality, because of the uncertain character of the test and the difficulty of so conducting it as to make it a reliable indication of value. The adhesive properties of the cement are to a certain extent called into play in tests of sand mortar, and may be inferred from comparison of neat and sand tests.

Experiments upon the adhesion of mortars to various substances are sometimes made, both for the purpose of comparing the cements or methods of use, and to study the relative adhesions to various kinds of surfaces. Such experiments are quite desirable with a view to the extension of knowledge of this very important quality.

The common method of making this test is to prepare briquettes of which one half the briquette is of cement paste or mortar and the other half a block of stone, glass, or other material to be used. The cement half is made in the ordinary form for tensile specimens. The other half is made to fit the cement mold at the middle and arranged at the end to be held by a clip in the testing machine.

#### ART. 7. SAND FOR MORTAR

**23. Quality of Sand.**—As hydraulic cement is commonly mixed with certain proportions of sand, when used in construction, the nature and quality of sand used, and the method of manipulating the materials in forming the mortar have quite as important an effect upon the final strength of the work as the quality of the cement itself.

In testing cement a standard sand is employed. This sand may be obtained quite uniform in quality. In the execution of work, however, local sand must generally be used; this varies widely in character, and should always be carefully considered upon any work where the development of strength and lasting qualities are of importance.

*Size of Sand Grains.*—It is usual to class as sand all material



less than  $\frac{1}{4}$ -inch diameter; pieces larger than this being classed as gravel. Coarse sand is superior to fine sand for use in cement mortar. Coarse sand presents less surface to be coated with cement and the interstices are more easily filled with cement paste. Fine sand requires more water in mixing to the same consistency, and gives usually weaker and more porous mortar than coarse sand.

The use of a mixture of grains of different sizes is usually desirable, giving less voids to be filled by the cement; and it is frequently found, when the cement is not in considerable excess, that the strength obtained by such a mixture is much greater than is given by either the large or small grains alone. Sand of mixed sizes, giving a minimum of voids, requires less cement to make a mortar of maximum density and strength than that of more uniform sizes.

*Shape of Grains.*—Sand with angular grains usually gives better results in mortar than that with rounded grains, and specifications frequently call for *sharp sand*. This difference is, however, much less important than that of proper gradation of sizes, and should not be given undue weight in the selection of sand for use in mortar.

*Stone Screenings.*—The screenings from crushed stone are frequently used in place of natural sand. Ordinarily screenings from stone of good quality give mortar of rather better strength than natural sand. This, however, depends in most instances upon the gradation of sizes in the two materials. The sharpness of grain is favorable to the screenings, and the presence of a certain amount of very fine stone dust in the screenings seems to be of value in the mortar. When the screenings are derived from soft rock, the dust may be present in too large amount and need to be screened out before the screenings can be successfully used.

*Chemical Composition.*—Sands as commonly used for mortar are composed mainly of silica. In most cases, sand which has a proper granulometric composition is satisfactory for use. The failure of concrete work has, however, in a number of instances been found to be due to the use of sand low in silica. Sand containing less than 95 per cent silica needs to be carefully tested before being used, although some sands as low as 75 per cent silica have given good results. The composition of sands have not been sufficiently studied to determine the differences of composition which cause failure in one case and success in another.

The presence of mica in sand or screenings is supposed to injuriously affect the strength of mortar in which the material is used. The results of experiments upon the effect of mica are not conclusive, although they seem to indicate that mica may sometimes be injuri-

ous. Sand containing mica should be carefully tested before being used.

*Effect of Impurities.*—Sand for use in mortar should be clean, and as free from loam, mud, or organic matter as possible. In general the presence of any foreign matter is to be avoided, though a small amount of fine clay distributed through sand has sometimes been found to increase the strength of cement mortar, and also helps to make the mortar work more smoothly, sometimes decreasing its permeability. The effect of the clay depends upon the character of the sand and upon the richness of the mortar. Fine clay may help to fill the voids in an otherwise porous mortar with good effect, but may be deleterious in a rich mortar, or when it is not finely divided and uniformly distributed through the sand. In a particular instance, the effect of such an adulteration can be judged only by testing it.

Impurities of an organic nature are always objectionable in sand for use in mortar. When it is necessary to use sand containing such impurities, it should be carefully washed and tested. A very small amount of vegetable matter in sand has sometimes caused the failure of mortar to harden properly.

*Selection of Sand.*—Sands differ so greatly in their qualities that it is difficult by mere inspection of the materials to judge of their relative values for use in mortar. In choosing sand for use in important work, it is desirable not only to determine fully the physical characteristics of the available materials, but also to make actual tests of mortar by their use.

**24. Tests for Sand.**—Tests intended to determine the mortar-making qualities of sand may be made in three ways:

1. *Mechanical analysis* of the sand, with determination of voids in the sand.

2. *Density tests* of mortars made from the sand with the cement to be used in the work.

3. *Strength tests* of mortars made from the sand in question with the cement to be used in the work.

The value of sand depends mainly upon its granulometric composition. The sand which, mixed with a given proportion of cement, gives the most dense mortar yields the strongest mortar. The sand which requires the least cement to make a mortar of maximum density is the most economical sand, when the mortar is properly proportioned.

The purpose in testing the sand should be to determine the proportions of cement to sand necessary as well as to choose the best sand.

**25. Mechanical Analysis.**—To determine the relative sizes of grains composing sand, the material is screened through a series of sieves of varying degrees of fineness. The sieves are made of standard size, 8 inches in diameter by  $2\frac{1}{4}$  inches high, those with openings smaller than  $\frac{1}{10}$  inch being made of woven brass wire, while the larger sizes are preferably drilled circular openings in sheet brass. These sieves are designated by numbers corresponding to the number of meshes to the linear inch, the size of opening depending upon the diameter of wire used. The size openings usually employed for sand analysis are approximately as follows:

|                         |      |      |       |       |      |      |       |       |        |
|-------------------------|------|------|-------|-------|------|------|-------|-------|--------|
| No. of Sieve. . . . .   | 4    | 10   | 20    | 30    | 40   | 50   | 80    | 100   | 200    |
| Size Opening, in. . . . | 0.25 | .073 | .0335 | .0195 | .015 | .011 | .0067 | .0055 | .00265 |

For ordinary examination of sand, when comparing or selecting sand for use, it is unnecessary to separate into so many sizes, and sieves Nos. 4, 10, 20, 50, and 100 are commonly employed. The sieves are made to fit together in nests with a cover and tight bottom to catch the residue from the finest sieves. The sifting may be done by hand, by shaking and jarring the sieves, or mechanical shakers may be used. These may be obtained to work by hand or with small electric motors attached.

In making the tests, a sample weighing 50 g. is dried to constant weight at temperature not more than  $110^{\circ}$  C. ( $230^{\circ}$  F.) and is then sifted through the sieves, so as to separate the grains into various sizes and determine the percentage of each by weight. The material properly classed as sand is that which passes through the No. 4 sieve and is retained on the No. 100 sieve. Sand retained by the No. 10 or No. 20 sieve may be classed as *coarse* sand; that caught between the No. 20 and No. 50 sieves is *medium* sand; that which passes the No. 50 sieve is *fine* sand. Material passing the No. 100 sieve is called *dust*.

*Analysis Curves.*—Comparisons of the granulometric compositions of sands are readily made by plotting the results of the sieve analysis as curves. It is usual to plot the sizes of openings as abscissæ and percentages passing each size as ordinates. The reciprocals of the numbers of the sieves may be used for size without impairing the value of the results, and probably represent more nearly the actual sizes of grains passing the sieves than does the computed width of opening. Table II gives the results of analyses of sands in common use for mortar, showing something of the variations which may frequently occur.

These results are plotted in Fig. 1. Sand No. 1 is a coarse bank



sand containing a small amount of clay. No. 2 is a medium river sand of good quality. No. 3 is a fine sand. No. 4 is screenings from broken limestone, containing rather high percentage of dust.

TABLE II.—ANALYSES OF SANDS

| Sieve No. | PERCENTAGES PASSING SIEVES. |       |       |             |
|-----------|-----------------------------|-------|-------|-------------|
|           | Sand.                       |       |       | Screenings. |
|           | 1                           | 2     | 3     |             |
| 4         | 100                         | 100   | 100   | 100         |
| 10        | 57.82                       | 85.18 | 99.82 | 95.07       |
| 20        | 34.96                       | 56.82 | 99.42 | 74.01       |
| 30        | 10.00                       | 33.93 | 97.33 | 59.68       |
| 40        | 7.67                        | 20.02 | 83.74 | 49.23       |
| 50        | 5.82                        | 13.07 | 35.13 | 41.91       |
| 80        | 3.69                        | 7.44  | 2.27  | 30.97       |
| 100       | 3.01                        | 5.18  | 0.96  | 28.24       |
| 200       | 1.73                        | 0.38  | 0.65  | 17.71       |

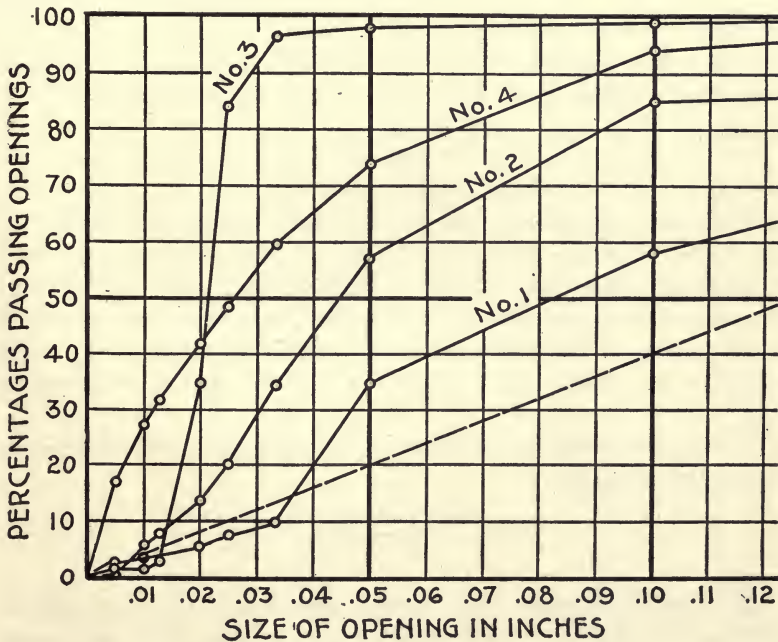

FIG. 1.—Analyses of Sands.



**26. Determination of Voids.**—The method most commonly used for void determination is known as the *wet method*, which consists in filling a measure with the sand to be tested and pouring in water until the voids are completely filled. The volume of water required to fill the voids divided by the volume of sand and multiplied by 100 is the percentage of voids; or the weight of water poured into the sand divided by the weight of water required to fill the measure and multiplied by 100 is the percentage of voids. It is very difficult to eliminate completely the air from the sand in making this test. The test is therefore liable to considerable error unless great care be used in manipulating it.

*Dry Method.*—A more accurate method of determining voids is to compare the weight of a measured volume of the sand with the weight of an equal volume of the solid material of which the sand is composed. In measuring the volume of sand, it is necessary to use care to secure the proper degree of compactness. For ordinary comparisons the sand should be well compacted by shaking and jarring the measure. The weight of the solid rock is obtained by multiplying the weight of an equal volume of water by the specific gravity of the sand. The difference between the weight of the rock and that of the sand divided by the weight of the rock and multiplied by 100 is the percentage of voids.

If  $R$  is the weight of the solid rock and  $S$ , the weight of the sand, percentage of voids is

$$\frac{R-S}{R}100.$$

This test supposes the sand to be dry. When it is desired to obtain the voids in moist sand, a weighed sample of the sand should be dried at 212° F. and the loss of weight determined. The weight of moisture in the measure of sand to be used in the test may then be computed. This weight is then to be subtracted from the total weight of the moist sand to find the weight of solid material in the sand.

If  $m$  is the weight of moisture in the volume of sand under test, percentage of voids is

$$\frac{R-(S-m)}{R}100.$$

**27. Specific Gravity.**—The specific gravity of siliceous sand is quite uniformly 2.65, or the weight per cubic foot of the solid rock is 165 pounds. To assume these values in determining the voids

in such sand involves slight error in any case. Sands not strictly siliceous may vary in specific gravity from about 2.6 to 2.7.

The determination of specific gravity is made by immersing a sample of the material in water at 68° F. and dividing the weight of the sand by the weight of water displaced. This is most conveniently done by sifting the sand into the water in a graduated glass tube, and reading the increase of volume of the liquid in the tube. Care must be used to introduce the sand slowly so as to eliminate all air bubbles.

**28. Density Test.**—Comparative tests of sands may be made by determining the volume of mortar produced by definite weights of cement and dry sand. The sand that for a given weight of materials, when mixed with the same proportion of cement to the required consistency, produces the smallest volume of mortar gives the most dense mortar. In making this test, molds in which the height is large in comparison with the section are convenient, the relative heights to which the mold is filled giving the proportionate volumes. The volume of mortar after setting is what is required, but the measurement before setting, unless the mortar is quite wet, will give practically the same result.

*Determination of Density.*—The term density, as commonly applied to mortar, means the ratio of the volume of solid materials contained in the mortar to the whole volume of mortar. The density is obtained by weighing the ingredients before mixing and calculating their solid volumes from these weights and their specific gravities. The weight and volume of the resulting mortar are then measured. The weight of mortar should equal the sum of the weights of the several ingredients. The density equals the sum of the solid volumes of sand and cement divided by the measured volume of the mortar. The density of mortars made from the sands shown in Fig. 1, one part cement to three parts sand by volume, are as follows:

| Sand No. | WEIGHTS USED, GRAMS. |       |        | Mortar Volume, c.c. | Density. |
|----------|----------------------|-------|--------|---------------------|----------|
|          | Cement.              | Sand. | Water. |                     |          |
| 1        | 358                  | 1026  | 178    | 670                 | 0.75     |
| 2        | 358                  | 1128  | 163    | 735                 | 0.73     |
| 3        | 358                  | 972   | 180    | 730                 | 0.66     |
| 4        | 358                  | 1122  | 268    | 790                 | 0.68     |

The method of computation is as follows:

Taking specific gravity of cement as 3.1 and specific gravity of sand as 2.65,

$$\text{Density of No. 1 is } \frac{\frac{358}{3.1} + \frac{1026}{2.65}}{670} = .750.$$

**29. Strength Tests.**—Tests of the strength of mortars made from sands are the most conclusive evidence of the mortar-making properties of the sands. These tests to be of real value should extend over a period of at least twenty-eight days. They are made in the same manner as the mortar tests for judging cement, and comparisons are sometimes made with the results of tests with standard sand. Table III gives comparative results of tests of the sands shown in Fig. 1.

TABLE III.—RESULTS OF SAND TESTS

| Sand No.   | PACKED SAND.       |                    | Density,<br>1 : 3<br>Mortar. | TENSILE STRENGTH. |           |               |           |
|------------|--------------------|--------------------|------------------------------|-------------------|-----------|---------------|-----------|
|            | Per Cent<br>Voids. | Weight,<br>Cu. Ft. |                              | 1 : 2 Mortar.     |           | 1 : 3 Mortar. |           |
|            |                    |                    |                              | 28 Days.          | 6 Months. | 28 Days.      | 6 Months. |
| 1          | 36.1               | 106.4              | .75                          | 523               | 603       | 443           | 495       |
| 2          | 28.6               | 117.5              | .73                          | 379               | 493       | 253           | 339       |
| 3          | 38.0               | 100.8              | .66                          | 223               | 343       | 153           | 265       |
| 4          | 28.7               | 116.7              | .68                          | 396               | 567       | 304           | 503       |
| Standard.. | ....               | .....              | ...                          | 326               | 477       | 268           | 318       |

**30. Washing Test.**—When it is necessary to examine sand for organic impurities, the silt may be removed from the sand by washing. This is done by shaking a sample of the sand in a bottle with water, letting it settle for a few seconds, and then pouring off the turbid water. This is done repeatedly until the suspended matter is all removed. The wash water is then evaporated, and the amount of silt determined.

The silt is ignited in a platinum crucible and the loss on ignition is the percentage of organic matter present.

A very small amount, not more than 1 per cent, of organic matter may be a serious detriment, sand containing such impurities should be carefully tested and may need to be washed in order to give satisfactory results in use.



**31. Specifications for Sand.**—Tests have seldom been used as means of judging sand for use in masonry construction. The requirements have usually been that the sand be coarse, clean, and sharp; the requirement of sharpness is now commonly omitted.

Mechanical analysis and void tests are frequently made for the purpose of judging the qualities of available sands on important work, and to aid in properly proportioning mortar, but such tests are not usual in specifications.

The Joint Committee of the Engineering Societies on Concrete and Reinforced Concrete has suggested the following as requirements for sand to be used as fine aggregate in concrete work:

(a) *Fine Aggregate.*—This should consist of sand, crushed stone or gravel screenings, graded from fine to coarse, and passing when dry a screen having holes  $\frac{1}{4}$  inch in diameter. It is preferable that it be of siliceous material, and should be clean, coarse, free from dust, soft particles, vegetable loam, or other deleterious matter; and not more than 6 per cent should pass a sieve having 100 meshes per linear inch. Fine aggregates should always be tested.

Fine aggregates should be of such quality that mortar composed of one part Portland cement and three parts fine aggregates by weight, when made into briquettes, will show a tensile strength at least equal to the strength of 1 to 3 mortar of the same consistency made with the same cement and standard Ottawa sand. If the aggregate be of poorer quality, the proportion of cement should be increased to secure the desired strength.

If the strength developed by the aggregate in the 1 to 3 mortar is less than 70 per cent of the strength of the Ottawa sand mortar, the material should be rejected. To avoid the removal of any coating on the grains, which may effect the strength, bank sand should not be dried before being made into mortar, but should contain natural moisture. The percentage of moisture may be determined on a separate sample for correcting weight. From 10 to 40 per cent more water may be required in mixing bank or artificial sands than for standard Ottawa sand to produce the same consistency.

## ART. 8. CEMENT MORTAR

**32. Proportioning Mortar.**—In specifying the proportions of ingredients for cement mortar to be used in construction, it is usual to give the ratio of parts of cement to those of sand by volume. The relative proportions of sand and cement to be used in any instance depend upon the nature of the work and the necessity for developing strength or water-tightness in the mortar. The proportions commonly used in ordinary work are: for natural cement, one part cement to one part or two parts sand; for Portland cement, one part cement to two parts or three parts of sand. In common practice these ratios are chosen without reference to the particular materials used and the resulting mortars vary widely in character.



Good sand in a 1 to 3 mortar frequently shows greater strength than a poorer one mixed 1 to 2, and gives equally good results in use.

The methods of measuring materials also vary, and the relative quantities of cement and sand in the mortar differ correspondingly.

*Measuring Cement.*—Cement should always be measured by weight, on account of the variation in volume of the same quantity of cement with different degrees of compactness. In specifying proportions by volume, therefore, it is always desirable to state the weight of cement to be taken as unit volume.

Portland cement is usually packed in wooden barrels or in canvas bags. A barrel of cement contains 376 pounds of cement, while a bag contains 94 pounds, or one-quarter barrel. Natural cement is ordinarily packed in barrels of 282 pounds, or bags of 94 pounds (one-third barrel) each.

Portland cement as packed in barrels weighs a little more than 100 pounds per cubic foot. A cubic foot of cement paste requires from 95 to 110 pounds of cement. It is common to consider a cubic foot of Portland cement to weigh 94 pounds in proportioning mortar. A bag of cement is then mixed with 2 cubic feet of sand to form 1 to 2 mortar, or with 3 cubic feet of sand to form 1 to 3 mortar. This assumes the volume of a barrel of cement to be 4 cubic feet. This is the recommendation of the Joint Committee of the Engineering Societies. Some engineers use 3.8 cubic feet as the volume of a barrel, or 100 pounds as the weight of a cubic foot.

In the same way, 70 pounds is frequently used as the weight of a cubic foot of natural cement. This makes the volume of a sack of natural cement  $1\frac{1}{3}$  cubic feet. A barrel of natural cement would then have the same nominal volume as a barrel of Portland, 4 cubic feet. The actual volume-weight of natural cement varies considerably for different brands.

*Measuring Sand.*—It is usual to measure sand by volume. The method of measuring to be used in any particular instance depends upon the method of mixing and handling the mortar. Very commonly the measuring is done in the barrow or bucket in which the sand is carried to the mixer or platform. Measuring boxes without bottoms are often employed to set on the mixing platform, and after filling are removed, leaving the measure of sand. Whatever method of handling the sand is employed, it is important that careful attention be given to securing the correct proportion of sand for the mortar.

*Effect of Moisture.*—In proportioning mortar by volume, the

moisture content of the sand may be a matter of importance. Damp sand weighs less per unit volume than dry sand. When sand is moistened with a small quantity of water, the grains of sand are coated with a thin film of water, which separates the grains, causing the sand to occupy more space than when dry. When the amount of water becomes sufficient to coat all the grains of sand (about 4 to 7 per cent with ordinary sands), a maximum effect is reached, and an increase in amount of water beyond that point causes a reduction of volume. At saturation (10 to 20 per cent of water), it becomes slightly less in volume than when dry.

The solid content in a given volume of moist sand is less than that of the same volume of dry sand, and a mortar mixed with the moist sand will be richer in cement than that mixed with the same sand when dry. This effect is greater with fine than with coarse sand. A given volume of sand measured dry may contain 10 per cent to 15 per cent more solid material than the same volume of the same sand measured in a moist condition.

The extent to which differences in moisture condition may effect the volume of the sand depends upon the position in which the sand is placed and the way it is handled in measuring. If dry sand in a bin, or a pile, be moistened with a small quantity of water, the sand will not appreciably swell in the pile, as the particles are held by the weight of the mass above—they are not free to move and the water fails to separate them. If the sand be loosened in moving to a new position, it will be found to have increased in volume and will not return to its former dimensions until it has become dry, or wet to saturation.

*Proportioning by Weight.*—In Germany it has been quite common to measure the material for mortar by weight. This has been applied in some instances in the United States, and reduces largely the variations in the proportions due to moisture. On important work it may frequently be possible to arrange for weight measurement without materially increasing the cost of handling the material.

The ratio of cement to sand is commonly arbitrarily fixed with reference to the particular use to which the mortar is to be put, without considering the character of the sand to be used. For ordinary masonry, or massive concrete, Portland cement is usually employed in 1 to 3 mixtures. When high strength is needed, as in reinforced concrete work, the mixture is 1 to 2. Under specially trying conditions, or sometimes when cement grout is being used, a 1 to 1 mixture may be employed. With natural cement, the mixtures are 1 to 2 for ordinary work and 1 to 1 where greater strength

is needed. Natural cement is not used for reinforced concrete work. The choice of ratios has usually been well on the side of safety, and good results have been obtained in practice by this method, although equally good work at less cost might in many instances have been obtained by more careful study of the materials in proportioning the ingredients of the mortar.

In comparing the mortar-making qualities of various sands, it is found that the amount of cement necessary to make mortar of the same strength from different sands depends mainly upon the fineness and density of the sands. The office of the cement paste in mortar is to coat the grains of sand and fill the voids between them. In fine sand the surface to be coated with cement is greater than in coarse sand. Dense sand, with grains of varying sizes, presents less voids to be filled than more uniform sand.

It is desirable that careful study be given to the sands to be used in any important work before finally deciding upon the proportions of the materials, and that final judgment be based upon actual tests of the mortar itself.

Frequently a mixture of a fine with a coarse sand, or of crusher dust with sand may be so proportioned as to give economical results in the saving of cement, while at the same time improving the mortar.

**33. Mixing Mortar.**—In mixing mortar by hand a water-tight box or platform is used. The required quantity of sand is spread over the floor of the box and the cement distributed evenly over the sand. The cement and sand are then mixed together with a hoe or shovel until the cement is uniformly distributed through the sand, as shown by the even color of the mixture dry. It is important that the dry materials be very thoroughly mixed before water is added. A uniform mixture will not otherwise be obtained. When the mixing of dry materials is complete, water is added and the mass worked into a stiff paste. The quality of the mortar is materially affected by the vigor with which it is worked in bringing it to the proper consistency. After the water has been absorbed by the cement, vigorous working will make the mass more plastic, and working should continue until a permanent condition is reached.

*Quantity of Water.*—The quantity of water to be used in mixing mortar can be determined only by experiment in each instance—it depending upon the nature of the cement and sand, and the proportion of cement to sand. The quantity of water used should be the least consistent with reducing the mortar to the required condition of plasticity by vigorous working. Additional water should not be used to save labor in working.



Mixing should be quickly and energetically done, only such quantity being mixed at once as can be used before initial set takes place. A considerable quantity is sometimes mixed dry and left to stand until needed before adding water. If this is done with damp sand, the cement may be acted upon by the moisture in the sand to the injury of the mortar. Quick-setting cements are particularly liable to injury from this cause.

*Retempering.*—Masons frequently mix mortar in considerable quantities, and if the mass becomes stiffened before being used, add more water and work again to plastic condition. After the second tempering the cement is much less active than at first, and remains a longer time in a workable condition. This practice is not approved by engineers and is not permitted in good engineering construction, although there is some dispute as to the extent of the injurious effects.

Cement when retempered becomes very slow in action, both in setting and hardening. The quicker-setting cements are usually more affected than the slow setting. The strength during the earlier periods of hardening is lessened, although the final strength may not be impaired. Portland cement may ordinarily be used for two, or sometimes three hours after mixing without appreciably affecting its action. When retempered after a longer period it will usually become slower in action, but may in some cases gain as much strength in thirty to sixty days.

Continuous working materially improves the strength of mortar, and when allowed to stand after mixing it should be frequently worked.

*Grout.*—Mortar when made thin, so that it can be poured into cracks or small openings, is known as grout. Mixtures of cement and sand used in this manner are difficult to handle without separation of the materials. They should be used only under exceptional circumstances and when stiffer mortar cannot be applied.

**34. Yield of Mortar.**—The volume of mortar formed by mixing given quantities of cement and sand depends mainly upon the densities of the materials. It is affected by the method of preparing the mortar, the uniformity of the mixture, and the degree of compactness. The net volume of materials entering into the composition of mortar is readily found from their weights and densities, but it represents only approximately the resulting volume. An accurate knowledge of the yield of any particular mixture is to be obtained only by experimenting upon the materials to be employed.

The amount of cement paste made by a given weight of cement

powder varies with the specific gravity of the cement and the amount of water necessary in gaging. The lighter cements require more water and yield less paste for a given volume of cement than the heavier ones. To form a cubic foot of plastic paste requires usually from 80 to 95 pounds of natural cement, while from 95 to 101 pounds of Portland cement are necessary.

Table IV gives approximate quantities of materials ordinarily required for 1 cubic yard of compact plastic mortar. A barrel of cement is taken as 4 cubic feet, corresponding to a weight of 94 pounds per cubic foot for Portland cement and 70 pounds for natural cement. The sand is dry and measured loose.

TABLE IV.—MATERIALS FOR 1 CUBIC YARD OF MORTAR

| PROPORTIONS. |       | QUANTITY OF SAND TO 1 SACK CEMENT. |                  | MATERIALS FOR 1 CU. YD. COMPACT, PLASTIC MORTAR. |                |
|--------------|-------|------------------------------------|------------------|--|----------------|
| Cement.      | Sand. | Portland, Cu. Ft.                  | Natural, Cu. Ft. | Cement, Barrels.                                 | Sand, Cu. Yds. |
| 1            | 0     | ...                                | ...              | 6.75 to 7.85                                     | .....          |
| 1            | 1     | 1.0                                | 1.3              | 4.25 to 4.75                                     | 0.63 to 0.70   |
| 1            | 2     | 2.0                                | 2.7              | 2.95 to 3.15                                     | 0.87 to 0.93   |
| 1            | 3     | 3.0                                | 4.0              | 2.20 to 2.37                                     | 0.98 to 1.04   |
| 1            | 4     | 4.0                                | 5.3              | 1.75 to 1.85                                     | 1.03 to 1.09   |

The differences in quantities are mainly due to variations in the fineness of the sand, in the amount of moisture contained by the sand, and in the compactness given to the mortar. Less materials are required when using fine than when using coarse sand; more materials are required when the sand is moist than when it is dry. The compactness of the mortar is affected by the quantity of water used in mixing and the method of placing the mortar.

**35. Mixtures of Lime and Cement.**—The addition of slaked or hydrated lime to cement mortar causes the mortar to work more smoothly, and makes it easier and more economical to handle in masonry construction.

A lean cement mortar may be improved in density and strength by the addition of a small quantity of lime paste. Lime in larger quantities, or lime added to rich mortar, diminishes the strength of the mortar but may sometimes be economical, through cheapening the mortar and improving its working qualities, when high strength is not of special importance.

Lime may be used with cement either by mixing lime paste with

cement mortar, or by mixing dry hydrated lime with cement before mixing the mortar. Lime must always be thoroughly slaked before mixing with cement, as unhydrated lime in cement mortar is always a detriment. It is also essential that the mixture be very uniform, and that the mortar be worked to an even color. For this reason, the use of dry hydrated lime is to be preferred over lime paste.

In proportioning lime to cement, the method of measurement is important. Hydrated lime from nearly pure limestone contains about 75 per cent of quicklime and ordinary lime paste contains about 40 per cent of lime by weight. About 25 pounds of quicklime are required to make a cubic foot of lime paste.

Experiments upon mixtures of lime and cement show that 10 to 15 per cent of lime (measured as unslaked lime) may be substituted for an equal weight of cement in a 1 to 3 cement mortar without sensibly decreasing the strength of the mortar. In some instances when not more than 10 per cent of lime is used the strength is increased and the mortar made more dense. As the proportion of lime is increased the strength of the mortar is lessened. For mortars leaner than 1 to 3 of Portland cement the use of a small amount of lime is usually an advantage.

With some natural cements, lime may be used to replace cement to the extent of 25 to 30 per cent of the weight of the cement without appreciable loss of strength in the mortar. Cement so treated becomes slower in action and is longer in gaining strength than when used without lime. Mixtures of this kind with either Portland or natural cement are frequently used in mortar for ordinary building operations. Hydrated lime is sometimes added to cement for the purpose of rendering the mortar less permeable where water-tight work is needed, and is also sometimes added to Portland cement concrete in small quantity to make the concrete flow more readily in filling the forms.

**36. Strength of Cement Mortar.**—The strength of cement mortar is dependent upon the quality and proportions of cement and sand; the quantity of water used in gaging; the method of mixing and thoroughness of working; the temperature and moisture conditions under which it is kept during hardening; the age of the mortar.

The effect upon tensile strength of varying proportions of cement and sand is shown in Fig. 2, which gives the relative strengths for an average Portland cement, or cement paste, and mortars with standard sand, for a period of one year after mixing. Individual cements may vary quite widely from the curves shown. Some gain strength more slowly at first and continue to gain for a longer



period. Others have greater early strength and show more loss of strength during the period of retrogression.

Nearly all Portland cements after gaining strength rapidly for a time reach a maximum and then lose strength for a period. This loss of strength is usually regained later. It seldom occurs in less than three months or more than one year after the mortar is mixed. Cement which gains strength very rapidly and has high early strength is apt to suffer greater loss of strength later than cements

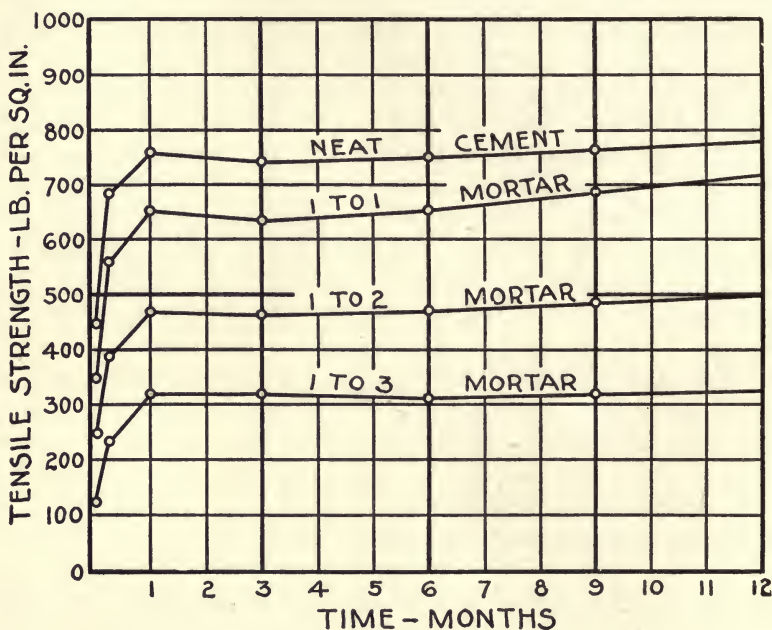

FIG. 2.—Strength of Portland Cement Mortar.

of more moderate action, and less likely to regain fully the losses. Mortars usually show less of the effects of retrogression than cement paste, and frequently continue to gain strength for much longer periods.

Fig. 3 shows average values for good grades of natural cement. These cements vary more widely than Portlands. They gain strength much more slowly and continue to gain for a longer period.

*Character of Sand.*—Coarse, well-graded sand usually gives higher strength in cement mortar than standard Ottawa sand while fine or poorly graded sand may fall below the strength shown by standard sand. Sands showing less than 75 per cent of the strength

given by standard sand are poor materials and are sometimes rejected by specifications for masonry materials.

*Fineness of Cement.*—The fineness of the cement has an important influence upon the strength of mortar. Table V shows the results

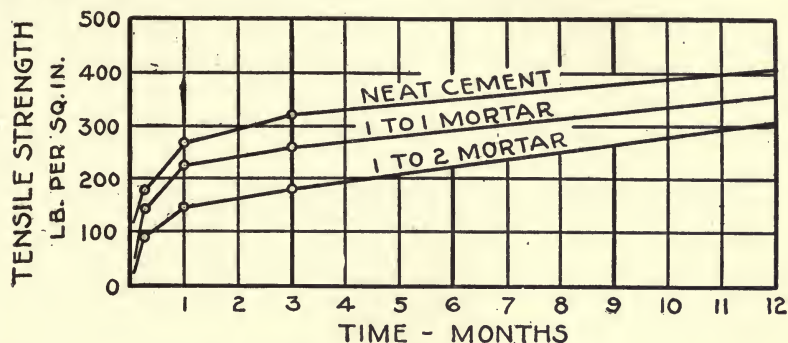

FIG. 3.—Strength of Natural Cement Mortars.

of a series of tests made upon Portland cement by Mr. Richard K. Meade.<sup>1</sup> In making these tests a bag of cement was selected and divided into five parts, and each of these ground to a different degree of fineness.

TABLE V.—STRENGTH OF THE SAME CEMENT GROUND TO VARIOUS DEGREES OF FINENESS

Tensile strength in pound per square inch.

| Age, Days. | Neat or Sand. | PER CENT PASSING NO. 200 SIEVE. |     |     |     |     |
|------------|---------------|---------------------------------|-----|-----|-----|-----|
|            |               | 80                              | 85  | 90  | 95  | 100 |
| 1          | Neat          | 396                             | 241 | 308 | 282 | 200 |
| 7          | Neat          | 955                             | 796 | 749 | 627 | 558 |
| 28         | Neat          | 963                             | 840 | 775 | 626 | 594 |
| 1          | 1 to 3 sand   | 235                             | 248 | 351 | 363 | 382 |
| 28         | 1 to 3 sand   | 297                             | 353 | 468 | 498 | 576 |
| 7          | 1 to 4 sand   | 160                             | 204 | 234 | 247 | 263 |
| 28         | 1 to 4 sand   | 224                             | 266 | 324 | 377 | 392 |

The strength of neat cement is decreased by fine grinding, while the strength of sand mortar is increased by fine grinding. The same strength may be reached in sand mortar by using less cement when the cement is finely ground than when it is coarsely ground.

<sup>1</sup> Proceedings American Society for Testing Materials, 1908, p. 412.

In the table it is shown that the strength of 1 to 4 mortar with cement 90 per cent fine is stronger than 1 to 3 mortar with cement 80 per cent fine.

The desirability of fine grinding depends upon the relative costs of cement ground to different degrees of fineness. Fine grinding increases the rapidity of setting very rapidly, and many Portland cements if ground so that 95 per cent passes the No. 200 sieve become so quick setting that they could not be used for ordinary work. In order to secure greater fineness, the methods of manufacture would need considerable modification.

*Effect of Consistency upon Strength.*—The amount of water used in mixing mortar necessarily depends upon the requirements of the use to be made of the mortar. The mortar used in concrete is usually much softer than that employed in masonry construction, or than the consistency used in testing.

For well-compacted mortar, strength decreases as the quantity of water used in mixing increases. The extent of this effect varies with the character of the sand, being less for coarse than for fine sand. This difference is very considerable in short time tests, but disappears to considerable extent as the age of the mortar increases. When tested after seven and twenty-eight days, mortar of standard consistency may have nearly double the strength of that mixed with 50 per cent more water.

Cement mortar hardens more rapidly and attains greater strength if kept moist during setting and the first period of hardening than if it be exposed at that time to dry air.

## ART. 9. GYPSUM PLASTERS

**37. Classification.**—Pure gypsum is a hydrous lime sulphate ( $\text{CaSO}_4 + 2\text{H}_2\text{O}$ ). It occurs in nature as a massive rock, or sometimes as gypsum sand or earth. Native gypsum usually contains small amounts of silica, alumina, iron oxide, and calcium carbonate. Alabaster is a massive rock of nearly pure white gypsum.

Native gypsum is ground and used as a dressing for certain soils. It is also used quite extensively as an adulterant in the manufacture of Portland cement. (See Section 12.)

*Gypsum plasters* are made by calcining gypsum sufficiently to drive off part or all of the water of combination. When this dehydration is accomplished at a temperature below  $190^\circ\text{C}$ ., three-fourths of the water is driven off and the resultant product is called *plaster of paris* ( $\text{CaSO}_4 + \frac{1}{2}\text{H}_2\text{O}$ ). At a temperature above  $190^\circ\text{C}$ . all of



the water is driven off and the product is known as *flooring plaster* ( $\text{CaSO}_4$ ). These products are modified by adding certain substances to the gypsum before calcining, or by the use of impure gypsum.

The following classification of gypsum plasters is given by E. C. Eckel in his "Cements, Limes and Plasters":

#### CLASSIFICATION OF PLASTERS

(a) Produced by the incomplete dehydration of gypsum, the calcination being carried on at a temperature not exceeding  $190^\circ\text{C}$ .

(1) *Plaster of paris*, produced by the calcination of a pure gypsum, no foreign materials being added either during or after calcination.

(2) *Cement plaster* (often called *patent* or *hard wall plaster*) produced by the calcination of a gypsum containing certain natural impurities, or by the addition to a calcined pure gypsum of certain materials which serve to retard the set or render more plastic the product.

(b) Produced by the complete dehydration of gypsum, the calcination being carried on at temperatures exceeding  $190^\circ\text{C}$ .

(3) *Flooring plaster*, produced by the calcination of a pure gypsum.

(4) *Hard finish plaster*, produced by the calcination at a red heat or over, of gypsum to which certain substances (usually alum or borax) have been added.

Plaster of paris and cement plaster are usually burned at temperatures from  $140^\circ$  to  $180^\circ\text{C}$ ., the difference between them being due to the substances added to the gypsum in making the cement plaster. Flooring plaster and hard-finish plaster are burned at  $400^\circ$  to  $500^\circ\text{C}$ . for three or four hours. If the heat be too high or too prolonged, the plaster may be injured, becoming very slow in action, and is called dead-burnt plaster.

*Keene's Cement* is a well-known hard-finish plaster made by the double calcination of gypsum, alum being added between the two heatings.

Cement plaster, after being calcined, requires the addition of some material as a retarder to decrease the rapidity of set. This is usually a very small quantity (0.1 to 0.2 per cent) of organic matter such as blood or glue. Hydrated lime or clay is usually added to gypsum wall plasters to increase their plasticity and make them work better. With plasters made from gypsum earth containing clay this is unnecessary.

**38. Properties and Uses.**—Gypsum plasters when mixed with water set and harden through the combination of the water with the plaster to again form gypsum. The setting of plaster of paris is rapid, requiring from about five to fifteen minutes. Cement

plaster sets more slowly, requiring from one to three hours. Floor plaster and hard-finish plaster are slow setting.

Very few data are available concerning the strength of gypsum plasters, which usually gain strength rapidly for a few days, reaching a maximum in three or four weeks, and then suffer retrogression in strength for a time. A series of tests made by Professor Marston of Iowa State College on hard wall plasters indicate a strength for neat plaster of 300 to 500 lbs./in.<sup>2</sup> one month after mixing. About 80 per cent as much for 1 to 1 mortar and 50 per cent as much for 1 to 2 mortar with sand. These strengths would not be reached under the conditions of ordinary use. The strength is much less when the mortar is kept damp during the period of hardening.

Plaster of paris sets too rapidly for use in construction, although it is used to some extent combined with other materials, as in hard finish, composed of plaster of paris, lime putty, and marble dust. It is commonly employed for casting plaster, where quick set is desired.

Cement and hard wall plasters are used for making various wall plasters, being usually mixed with hair, asbestos, or wood fiber, and clay or hydrated lime. They are received upon the work ready for use and do not require the time or space for preparation needed for lime plaster, but are not so plastic and smooth to work.

Hard-finish plasters are used in a number of ways in making solid or hollow blocks and tiles for use in construction of partitions and in finishing floors and ceilings. Mixed with sawdust, blocks are formed which may be nailed into place. Blocks reinforced with steel are now being made for use in supporting roofs. (See Art. 18.)

## CHAPTER III

### STONE MASONRY

#### ART. 10. BUILDING STONE

**39. Qualities for Building Stone.**—The choice of stone for use in important structures is always a matter of moment, and frequently involves considerable difficulty, on account of the wide variation in the characteristics of the stones commonly used. Stones belonging to the same classes frequently differ greatly in their physical properties and much care needs to be exercised in securing materials of proper strength and endurance.

The qualities which are of importance in the selection of stone for structural uses are strength, durability, appearance, and cost. The relative importance of these in any particular structure depends upon the location of the structure and the purpose for which it is intended. For ordinary masonry, the most important quality of the stone is usually its durability. The element of strength is commonly of minor consequence, except in portions of a structure where the conditions are such as to bring severe stresses upon the masonry. A pleasing appearance is always desirable, but any stone possessing proper structural qualities may usually be so employed as to produce a good effect, where the purpose of the structure is not distinctly artistic. In architectural and monumental work, the appearance of the stone may be of first importance, while the strength of the stone, or its cost, is of less consequence. Stone for such uses, when in exposed situations, must possess durability in order to preserve the beauty of the structure and prevent disfigurement or discoloration of its surfaces.

The cost of the stone is always a matter of importance, commonly limiting the choice, and frequently being the determining factor in selection of stone. The cost of stone depends mainly upon the ease with which it may be quarried and worked, and the distance and means of transportation to the place where it is to be used. The equipment of a quarry for handling and working stone often determines its availability for a particular use. The kind of finish



to be given the surfaces, and the suitability of the material to the proposed treatment are also important in their effects upon cost.

A good building stone should be dense and uniform in structure, and should have no seams or crow-foots filled with material which may disintegrate and form cracks upon exposure. The fracture should be clean and sharp, and the surface free from earthy appearance.

Hardness and toughness are important properties in a stone which is to be subjected to wear or abrasion of any kind. Stones lacking in toughness and easily abraded have sometimes been seriously defaced by dust and sand particles carried by strong winds. The hardness of the stone depends both upon the hardness of the minerals of which it is composed and upon the firmness with which they are bound together. Toughness depends upon the resistance to separation of the mineral grains. Rocks of hard material may be lacking in toughness and easily worked when weakly cemented.

**40. Classification of Building Stones.**—All rocks are aggregations of various mineral constituents, more or less firmly held together. Geologically, as to their mode of occurrence, they are divided into three groups, as follows:

(1) *Igneous Rocks*.—Those which have been forced up in a molten condition from unknown depths and subsequently cooled. When the molten rock has cooled and solidified below the surface of the ground it is known as *plutonic*, when above ground as *volcanic*.

(2) *Sedimentary or Stratified Rocks*.—Rocks formed by being deposited as sediment in layers, and consequently showing bedding lines and stratifications. Limestones and sandstones belong in this class.

(3) *Metamorphic Rocks*, formed by subjecting igneous or stratified rocks to great heat or pressure or to both.

Building stones may also be classified according to their chemical and physical properties into three groups:

Crystalline, siliceous rocks, including granites, gneisses, traps, etc.

Calcareous rocks, including limestones and marbles.

Fragmental rocks, including sandstones and slates.

*Granite* is a crystalline siliceous rock of igneous origin. It consists essentially of quartz, with some feldspar and usually mica. It is readily quarried into blocks of regular shape, but is very hard and tough and is expensive to cut for ornamental work. It is the strongest and most durable of our building stones in common use, and is very generally employed in important work where these qualities are of special importance. Heavy foundations, base courses,

water tables, and columns in important buildings are very commonly of granite.

The color of granite is usually gray, but pink, red, and black granites are found. It is largely used in monumental work and in architecture for exterior work where the most beautiful and durable results are desired. The use of machinery for working the stone has made this use economically feasible.

*Syenite* is a rock similar to granite, but composed mainly of feldspar instead of quartz. It has much the same qualities as granite and is usually classed as granite when used.

*Diorite* and *Gabbro* are rock of the same general character as granite but differing in mineral composition. They are usually classed commercially as granites.

*Gneiss* is a metamorphic rock of the same composition as granite. It is metamorphosed granite or syenite, and usually classed as granite, being often called stratified or bastard granite. Gneiss differs from granite in having a somewhat laminated structure which causes it to split in parallel layers. It is often used for flagging and paving blocks on this account.

Granites are found quite widely distributed in the mountain regions of the United States. The main supply comes from the New England States, where large quarries are in operation and have gained wide reputation. Commercial granites of good quality are found in the South Atlantic States, in Wisconsin and Missouri, while Montana, Wyoming, Colorado, California, and Washington are plentifully supplied with granite which is comparatively undeveloped.

*Limestones* are sedimentary calcareous rocks, consisting mainly of the mineral calcite, which is composed of calcium carbonate ( $\text{CaCO}_3$ ). They also usually contain small amounts of iron oxide, silica, and clay. Magnesia is also commonly present in the pure limestones in very small amounts, and varying—through the magnesian limestones, in which 10 per cent or more of magnesia is present—to dolomite, which consists mainly of the mineral dolomite ( $\text{CaMgCO}_3$ ).

Limestone varies from stone soft enough to cut with a saw to hard material which works with difficulty. Some of the soft stones harden on exposure and are durable in use, the Topeka stone used in Kansas being of this character. Many of the fine-grained, light-colored limestones form excellent building material; they are hard and tough and show good durability in use, although inferior in this respect to the best sandstone and granite. Some of them are used

in ornamental work and take good polish. Stone containing pyrite is apt to show poor weathering qualities, while spots of flint found in many of these stones are objectionable on account of weathering unevenly and sometimes causing the stone to split under frost action.

The following analysis of typical limestones are given by Ries<sup>1</sup> to show the range of chemical composition:

|   | I     | II    | III   | IV    |
|---|-------|-------|-------|-------|
| Calcium carbonate (CaCO <sub>3</sub> ).....         | 97.26 | 54.53 | 81.43 | 98.91 |
| Magnesian carbonate (MgCO <sub>3</sub> )..          | 0.37  | 39.41 | 15.04 | 0.58  |
| Alumina (Al <sub>2</sub> O <sub>3</sub> ).....      | 0.49  | 0.26  | 0.57  | 0.63  |
| Ferric oxide (Fe <sub>2</sub> O <sub>3</sub> )..... |       |       |       |       |
| Silica (SiO <sub>2</sub> ).....                     | 1.69  | 3.96  | 2.89  | 0.10  |
| Water (H <sub>2</sub> O).....                       | ..... | 1.50  | 0.08  | ....  |

Limestones exist in large quantities through the States of the Middle West, and are locally developed in many places. The well-known Bedford, Indiana, stone is extensively used and shipped for considerable distances.

*Marbles* are limestones which have been subjected to metamorphic action. In composition they are identical with limestones, or dolomites, but are crystalline in texture and may be polished. The term marble is commonly used to designate any limestone capable of taking a polish.

Marbles are commonly employed for interior finish in buildings and for monumental work. The scarcity and cost of the best marbles have prevented their extensive use for ordinary building construction. Their weathering properties are similar to those of limestone, although some of the more ornamental ones are suitable for interior work only. For structural work the more dense fine-grained stone is to be preferred.

*Sandstones* are essentially grains of quartz cemented together. Iron oxide, silica, carbonate of lime, or clay may be the cementing medium. The character of the stone varies with that of the cement binding the sand grains.

Sometimes other minerals than quartz are present in sandstones, as feldspar, mica, or pyrite, thus modifying the character of the stone, usually rendering it less durable. Sandstones in which silica is the cementing material are usually the most durable. They are commonly light in color. When considerable silica is present, the stone

<sup>1</sup> Building Stones and Clay Products, New York, 1912.



is very hard and difficult to work, while some stones containing less cement work easily and remain gritty under wear.

Sandstone in which the cement is iron oxide is usually of a red or brown color. These stones usually work easily, and are often durable in use as building stones. When the cementing material is carbonate of lime, the stone usually possesses fair strength, but is not often so durable as that with silica or iron oxide. These stones are usually light colored, soft and easy to work. Clay as a cement in sandstone is usually less desirable than the others; the stone containing it is not so strong; it absorbs water and may be liable to injury from frost. When present in small amount and uniformly distributed through the stone, clay may make the stone easier to work without otherwise injuring it.

“Sandstones, as a rule, show good durability. Some of the softer ones may disintegrate under frost action. Those with clay seams are liable to split with continued freezing. Mica scales, if abundant along the bedding planes, are also likely to cause trouble, and this is aggravated if the stone is set on edge instead of on bed. A striking example of this is the Connecticut brown stone so extensively used in former years for fronts in many of the Eastern cities. In order to get a smooth surface it was rubbed parallel with the bedding, and the stone set in the building on edge. The result is that hundreds of buildings put up more than fifteen or twenty years ago are scaling badly, and in many cases the entire front has been redressed.”<sup>1</sup>

Sandstones are of sedimentary origin and are more or less in layers. They should always be laid on their natural beds, and are apt to scale off if placed on edge. They vary in texture from grains of powdery fineness to those in which the grains are of course sand. The fine-grained stones are usually the strongest and most durable.

Sandstone is quite widely distributed over the United States, and is one of the most desirable and most extensively used building stones. Many quarries are in use throughout the country for local purposes, while a few quarries supply stone for wider distribution. The Berea stone of Ohio is frequently shipped to considerable distances. The Brownstone of Connecticut, Medina sandstone of western New York, Kettle River sandstone of Minnesota are examples of well-known stones in common use.

*Slate* is a metamorphic rock produced from clay or shale. It is characterized by a tendency to split into thin sheets with smooth surfaces. The direction of this cleavage is not parallel to the bedding and has probably been caused by heavy lateral pressure. These

<sup>1</sup> Ries, Building Stones and Clay Products, p. 165.

sheets of slate are strong under transverse loading and quite impervious to water. They therefore make good roof covering, or may be used as flags for spanning openings. They are also commonly used for blackboards, school slates, etc. The color of slate is commonly dark blue, gray, or black, although green and red slates are also common.

Good slate should be dense and tough and not corrodible by atmospheric gases. When loaded transversely, it should bend appreciably before breaking, and should show a modulus of rupture from 7000 to 10000 lbs./in.<sup>2</sup>

Most of the slate now in use comes from the New England and Middle Atlantic States, notably from Vermont and eastern Pennsylvania. Important quarries have also been opened in Arkansas and California.

**41. Strength of Building Stone.**—The loads brought upon masonry structures are rarely sufficient to tax the strength of the stone in compression. The strength of masonry is not directly dependent upon that of the stone used in its construction. The strength of the mortar, thickness of joints, and the care and accuracy used in bedding the stones have important effects upon the strength of the masonry. It is desirable that building stone should be strong and capable of resisting heavy loads, and tests of the strength of the stone may show whether the stone is of good quality and fit for use.

When stone is to be used to span openings and carry transverse loads, its strength is important and care should be taken in its selection. The ability of stone to resist cross-bending stresses is mainly dependent upon its tensile strength. Tests of transverse strength may serve to detect brittleness and lack of toughness or uniformity in the texture of the stone.

*Tests for Compressive Strength.*—The compressive strength of stone is determined by measuring the loads necessary to crush small blocks cut from the stone. The results of such tests vary with the sizes and shapes of the blocks tested and the methods of placing them in the testing machine. It is necessary in comparing the strengths of different stones to use a standard form and size of specimen and standard method of testing. It is usual to use small cubes, 2 inches on the edge. The size does not seem to very greatly affect the resistance per unit area, but it is desirable to use blocks of the same size in making comparative tests.

The shape of the block is highly important in its effect upon the results of such tests. When subjected to compression, materials

of this kind break by shearing on planes making angles of about  $30^\circ$  with the direction of the compressing force. The ratio of the height of the specimen to its lateral dimensions is therefore important. The strength of the flat slab is much greater than that of a cube, while a prism whose height is greater than its breadth will show less strength on the test.

The test of small specimens gives no indication of the actual strength of the stone in large masses, and tests of this kind can be of value only as indicating the quality of the material, through comparison with the results of similar tests applied to other stones.

The method of preparing the specimen may be quite important in the results of a test. When the dressing is done with hand tools, the shocks frequently have the effect of weakening the internal structure of the stone. This effect with small specimens may amount to a decrease of 30 or 40 per cent as compared with the strength of sawed blocks. The use of sawed test pieces is desirable in such work.

The manner of placing the specimen in the testing machine is also important. It is essential that the test piece be accurately centered in the machine, and that it be evenly in contact with the pressing surfaces, in order to distribute uniformly the compressing force over the area of the block. If the surfaces of the test piece be carefully ground to parallel planes, and the piece carefully centered in the machine in exact contact with the metal surfaces, the best results will be obtained. This method, however, involves considerable labor in preparation of the specimen, and is expensive. The more common method is to set the specimen in a thin bedding of plaster of paris between the plates of the machine and leave it under light pressure for a few minutes, to allow the plaster of paris to set, before applying the load. This method, if carefully handled, gives uniform results, although the strength shown is somewhat less than that obtained by using ground surfaces.

A block of stone may have much less strength in one direction than in another. Most rocks have planes of cleavage in one direction in which they split more easily than in other directions. These planes are usually parallel to the natural bed of the rock and are known as the rift of the rock. Care should be taken to place the test specimen on its natural bed, or in such position that the compression is applied in a direction normal to the rift.

*Compressive Strength.*—The results of tests upon building stones show a wide variation in compressive strengths of different samples



of the same classification, as well as between different classes of stone.

Hard limestones usually show crushing strengths of 8000 to 12,000 lbs./in.<sup>2</sup>, although softer stones of good quality may run from 3000 to 6000 lb./in.<sup>2</sup>

Sandstones used in building vary in compressive strength from about 4000 to 15,000 lb./in.<sup>2</sup> The better grades of stone usually reach 9000 to 12,000 lb./in.<sup>2</sup>

Granites of good quality should show a crushing strength of 10,000 to 20,000 lb./in.<sup>2</sup>

*Transverse Strength.*—Tests of transverse strength are usually made on a small bar of stone, 1 inch square in section, and the method of preparing the specimen is important in its effect upon the results of the test. Comparatively little data exist concerning the strengths of stone under transverse loadings. The following table gives approximate values which have been obtained for ordinary stone used in building.

MODULUS OF RUPTURE, LB./IN.<sup>2</sup>

|                |                   |
|----------------|-------------------|
| Granite.....   | from 1400 to 2500 |
| Limestone..... | from 500 to 3000  |
| Sandstone..... | from 600 to 2000  |

In selecting stone for use as lintels, or where it is to carry transverse loads, it is desirable that the stone be tested in blocks of size comparable to those in which it is to be used. The results of tests upon small specimens is not of much value for this purpose.

The table on p. 59, by Herbert F. Moore, is taken from Merriam's "American Civil Engineer's Pocket Book."

**42. Durability of Building Stone.**—That stone should be durable under the conditions of use is evidently one of the most important points to be considered in the selection of material for use in construction. The situation in which the stone is to be placed and the climatic or other conditions which may affect the durability should therefore be carefully considered. Local conditions have frequently been overlooked in selecting stone, with disastrous results. The White House at Washington is of sandstone which requires frequent painting. The obelisk, in perfect condition after long exposure in Egypt, began to disintegrate almost immediately when set up in New York City. The Parliament House, built of stone selected with the greatest care, is not able to resist the disintegrating influences of the London atmosphere.

DATA FOR BUILDING STONES OF GOOD QUALITY

VALUES BASED MAINLY ON TEST DATA FROM THE WATERTOWN ARSENAL

| Kind of Stone.       | Weight,<br>Lbs.<br>per<br>Cubic<br>Feet. | Com-<br>pressive<br>Strength,<br>Lbs.<br>per<br>Square<br>Inch. | Shearing<br>Strength,<br>Lbs.<br>per<br>Square<br>Inch. | Modulus<br>of<br>Rupture,<br>Lbs.<br>per<br>Square<br>Inch. | Modulus<br>of<br>Elasticity,<br>Lbs.<br>per<br>Square<br>Inch. | Coefficient<br>of<br>Expansion<br>per<br>Deg.<br>F. | Absorp-<br>tion of<br>Water<br>Per<br>Cent<br>of<br>Weight<br>of Stone. |
|----------------------|--|---|---|---|--|---|---|
| Granite,<br>range,   | 160                                      | 15,000  | 1800  | 1200  | 5,900,000  |   |   |
|                      | to<br>170                                | to<br>26,000  | to<br>2800  | to<br>2200  | to<br>9,800,000  |   |   |
| Average..            | 165                                      | 20,200  | 2300  | 1600  | 7,500,000  | 0.0000040   | 0.5   |
| Sandstone,<br>range, | 135                                      | 6,700   | 1200  | 500   | 1,000,000  |   |   |
|                      | to<br>150                                | to<br>19,000  | to<br>2500  | to<br>2200  | to<br>7,700,000  |   |   |
| Average..            | 140                                      | 12,500  | 1700  | 1500  | 3,300,000  | 0.0000055   | 5.0   |
| Limestone,<br>range, | 140                                      | 3,200   | 1000  | 250   | 4,000,000  |   |   |
|                      | to<br>180                                | to<br>20,000  | to<br>2200  | to<br>2700  | to<br>14,000,000   |   |   |
| Average..            | 160                                      | 9,000   | 1400  | 1200  | 8,400,000  | 0.0000045   | 7.7   |
| Marble,<br>range,    | 160                                      | 10,300  | 1000  | 850   | 4,000,000  |   |   |
|                      | to<br>180                                | to<br>16,100  | to<br>1600  | to<br>2300  | to<br>12,600,000   |   |   |
| Average..            | 170                                      | 12,600  | 1300  | 1500  | 8,200,000  | 0.0000045   | 0.4   |
| Slate,<br>range,     | 170                                      | 140,000   | .....   | 7000  | 13,900,000   |   |   |
|                      | to<br>180                                | to<br>30,000  | .....   | to<br>11,000  | to<br>16,200,000   |   |   |
| Average..            | 175                                      | 150,000   | .....   | 8,500   | 14,000,000   | 0.0000058   | 0.5   |
| Trap, average        | 185                                      | 20,000  |   |   |  |   |   |

The range of changes in temperature, presence of moisture and gases in the atmosphere, and the action of winds and dust are the principal causes of deterioration in stones used in structures.

*Expansion and contraction* due to changes in temperature create an almost continual tendency to motion among the particles of the stone, an effect which is felt mainly at the exposed surfaces

where expansions are very unequal, and may cause the scaling of the surface layers. Surfaces exposed to the direct rays of the sun are most affected from this cause. In a number of instances, scaling of the surfaces on the south side of buildings has been observed, when the less exposed sides were free from it.

*Frost Action.*—When stone saturated with water is frozen, the expansion of the liquid in freezing causes a heavy internal pressure, which may be greater than the tenacity of the stone. In the climate of the Northern United States this is commonly one of the most active causes of disintegration of building stones, and the ability to resist frost action is of chief importance. The results of the action of frost on a stone depend upon the porosity of the stone and upon the texture and toughness of the material.

Granite usually absorbs not more than 1 per cent of water, and is not often appreciably affected by frost. Sandstones and limestones may absorb from about 2 to 12 or even 15 per cent. Ordinarily, a good stone that does not absorb more than 4 or 5 per cent of water may be expected to stand frost well. Some more porous stones have also shown well in use. A porous stone of coarse texture is more apt to resist frost action than one of fine texture. Moisture escapes more readily and the stone is less likely to be saturated when frozen.

*Fire Resistance.*—Any building stone may be injured if subjected to high heat as in the case of serious fires. This injury is intensified by contact of water when so heated. Unequal expansions and sudden surface contractions are likely to cause internal stresses beyond the strength of the stone.

Granites are apt to split and spall badly on the surface and usually show poor fire-resisting qualities. Limestones usually resist fire better than granite until the heat becomes sufficient to drive off the carbonic acid. At high heats they are destroyed. When suddenly cooled by water, limestone is likely to spall badly. Sandstones usually withstand fires better than other building stones, sometimes coming through severe fires without serious injury. They are, however, likely to spall and crack under the combined action of a hot fire and water.

*Chemical Agencies.*—Rock to be durable in use as building stone must be capable of resisting changes due to the presence of water and gases in the atmosphere.

Certain ingredients in the rock may be soluble in water carrying acids in solution; limestones commonly weather in this way, the carbonate of lime being somewhat soluble in water containing car-



bonic or sulphurous acid, hence these stones are usually liable to surface deterioration in cities. The extent of such deterioration is greater for the more absorbent stones.

Building stone may sometimes be discolored by the oxidation of pyrite or other iron compounds in its surface. This may or may not be an injury to the appearance of the structure. Pyrite is apt to cause rusty blotches which are objectionable, although when evenly and finely distributed through sandstone the result is sometimes enhances its appearance. Sandstones in which iron oxide is the cementing medium are often changed in color by oxidation. Siliceous sandstones are not affected in this manner.

*Seasoning of Stone.*—All stone is improved by being allowed to stand and dry out before being used in construction, the evaporation of the quarry water being accompanied by hardening of the stone, and the formation of a crust upon the surface. In most cases this indurating effect is comparatively small, but some soft limestones and sandstones, which are easily cut and weak when first quarried, soon acquire considerable hardness and strength, the supposition being that the quarry water contains a small amount of cementing material which is deposited in the pores of the stone upon the evaporation of the water. For this reason the cutting of the stone should be done before the seasoning has taken place, in order that the surface skin may not be broken. This is particularly the case where elaborate dressing or carving is to be done.

*Tests for Durability.*—Observations of the stone where it has been used in construction or where it has been long exposed in the quarry is the best means of determining the probable durability of a stone. Stone frequently varies considerably in character in different parts of the same quarry, and this must be taken into account in the selection.

There are no standard tests for durability. A number of tests have been proposed and sometimes applied for comparisons of stones, but there is no standard to which they may be referred.

*Absorption Tests.*—Tests to determine the amount of water absorbed by stone are sometimes made. A stone absorbing little water is less likely to be injured by frost or atmospheric gases than one absorbing water freely; in making this test, it is usual to dry the stone at 100° C. until it ceases to lose weight, then soak the stone for twenty-four hours in water and weigh again.

$$\text{The percentage of absorption} = \frac{\text{Weight of water absorbed} \times 100}{\text{Weight of dry stone}}$$

The method recommended for brick (see Section 59) may also

be employed for stone, although there is no standard for comparison of the results.

*Frost Tests.*—Tests of the effect upon a stone sample of repeatedly freezing and thawing it, while saturated, have sometimes been made. About twenty repetitions are usual, and the loss of weight or the loss in compressive strength of samples is measured. This test requires considerable time and a means of producing low temperatures. The differences obtained are usually very small, and not easy to evaluate.

Another test intended to simulate the effects of freezing is known as the *Brard test*, which consists in boiling the specimen in a concentrated solution of sulphate of soda, then exposing it to the air, and observing the effects as the salt crystallizes in the pores of the stone. This is much more severe than the ordinary freezing test, and may be partly due to chemical action.

*Acid Test.*—Samples of the stone are sometimes immersed in weak solutions of hydrochloric and sulphuric acid, to determine the presence of soluble material, by noting the loss of weight after several days. Exposure to an atmosphere of carbonic acid, or oxygen, is sometimes employed and changes of color observed. None of these tests has been definitely formulated and standardized.

#### BOOKS ON BUILDING STONE

Complete descriptions of the various building stones of the United States, with their properties and uses may be found in the following books:

Merrill's "Stones for Building and Decoration."

Ries' "Building Stones and Clay Products."

#### ART. 11. STONE CUTTING

**43. Tools for Stone Cutting.**—The kinds of finish used in dressing stone are usually defined by mentioning the tool with which the dressing is done. The following definitions were recommended by a committee of the American Society of Civil Engineers in 1877, and have since been commonly employed.

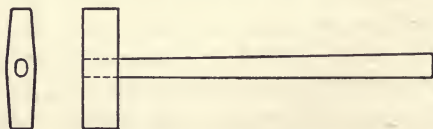

FIG. 4.—Double-face Hammer.

"The Double-face Hammer (Fig. 4) is a heavy tool weighing from 20 to 30 pounds, used for roughly shaping stones as they come

from the quarry, and knocking off projections. This is used only for the roughest work.

“The Face Hammer (Fig. 5) has one blunt and one cutting end, and is used for the same purpose as the double-face hammer where less weight is required. The cutting end is used for roughly squaring stones, preparatory to the use of finer tools.

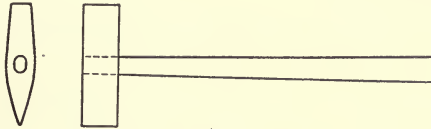

FIG. 5.—Face Hammer.

“The cavil (Fig. 6) has one blunt and one pyramidal end, and weighs from 15 to 20 pounds. It is used in quarries for roughly shaping stones for transportation.

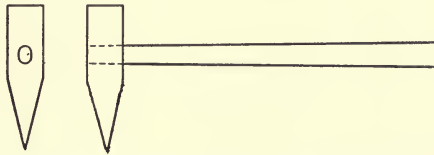

FIG. 6.—Cavil.

“The Pick (Fig. 7) somewhat resembles the pick used in digging, and is used for rough dressing, mostly on sandstone and limestone. Its length varies from 15 to 24 inches, the thickness at the eye being about two inches.

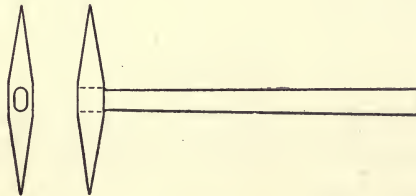

FIG. 7.—Pick.

“The Axe or Pean Hammer (Fig. 8) has two opposite cutting edges. It is used for making drafts around the arris, or edge of



stones, and in reducing faces, and sometimes joints to a level. Its length is about 10 inches, and the cutting edges about 4 inches. It is used after the point and before the patent hammer.

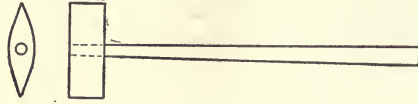

FIG. 8.—Axe or Pean Hammer.

“Tooth Axe (Fig. 9) is like the axe, except that its cutting edges are divided into teeth, the number of which varies with the kind of work required. This tool is not used on granite and gneiss cutting.

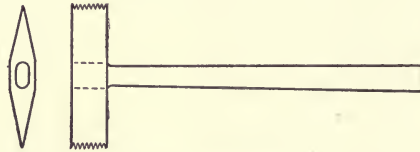

FIG. 9.—Tooth Axe.

“The Bush Hammer (Fig. 10) is a square prism of steel whose ends are cut into a number of pyramidal points. The length of the hammer is from 4 to 8 inches, and the cutting face from 2 to 4 inches square. The points vary in number with the size of the work to be done.

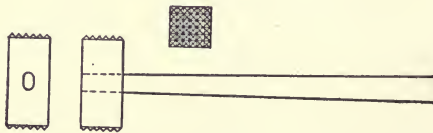

FIG. 10.—Bush Hammer.

“The Patent Hammer (Fig. 11) is a double-headed tool so formed as to hold at each end a set of wide thin chisels. The tool is in two

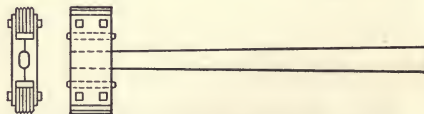

FIG. 11 —Patent Hammer.

parts which are held together by the bolts which hold the chisels. Lateral motion is prevented by four guards on one of the pieces. The tool without teeth is  $5\frac{1}{2} \times 2\frac{3}{4} \times 1\frac{1}{2}$  inches. The teeth are  $2\frac{3}{4}$  inches wide. Their thickness varies from  $\frac{1}{12}$  to  $\frac{1}{8}$  inch. This tool is used for giving a finish to the surface of stones.

“The Crandall (Fig. 12) is a malleable iron bar about 2 feet long, slightly flattened at one end. In this end is a slot 3 inches long and  $\frac{3}{8}$  inch wide. Through this slot are passed ten double-headed points of  $\frac{1}{4}$ -inch squared steel, 9 inches long, which are held in place by a key.

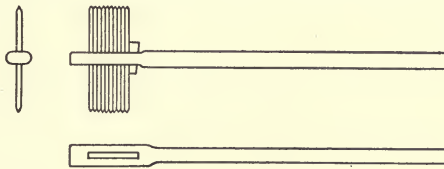

FIG. 12.—Crandall.

“The Hand Hammer, weighing from 2 to 5 pounds, is used in drilling holes, and in pointing and chiseling the harder rocks.

“The Mallet is used where the softer limestones and sandstones are to be cut.

“The Pitching Chisel (Fig. 13a) is usually of  $1\frac{1}{8}$ -inch octagonal steel, spread on the cutting edge to a rectangle of 1 by  $2\frac{1}{2}$  inches. It is used to make a well-defined edge to the face of the stone, a line being marked on the joint surface to which the chisel is applied, and the portion of the stone outside of the line broken off by a blow with the hand hammer on the head of the chisel.

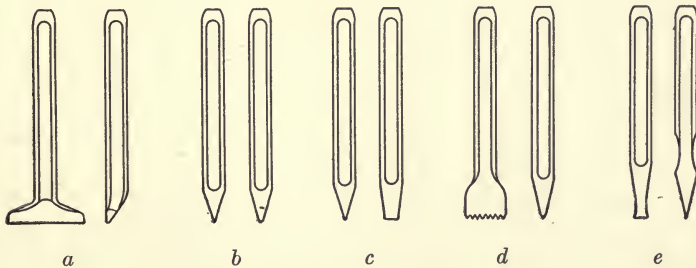

FIG. 13.—Chisels and Points.

“The Point (Fig. 13b) is made of round or octagonal rods of steel from  $\frac{1}{4}$  to 1 inch in diameter. It is made about 12 inches long, with

one end brought to a point. It is used until its length is reduced to about 5 inches. It is employed for dressing off the irregular surfaces of stones, either for a permanent finish or preparatory to the use of the axe. According to the hardness of the stone, either the hand hammer or the mallet is used with it.

"The Chisel (Fig. 13c) of round steel  $\frac{1}{4}$  to  $\frac{3}{4}$  inch in diameter and about 10 inches long, with one end brought to a cutting edge from  $\frac{1}{4}$  to 2 inches wide, is used for cutting drafts or margins on the faces of stones.

"The Tooth Chisel (Fig. 13d) is the same as the chisel except that the cutting edge is divided into teeth. It is used only on marbles and sandstones.

"The Splitting Chisel (Fig. 13e) is used chiefly on the softer stratified stones, and sometimes on fine architectural carvings in granite.

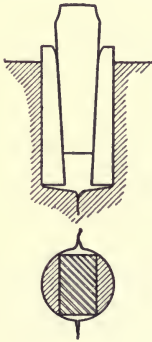

FIG. 14.

"The Plug, a truncated wedge of steel, and the Feathers, of half-rounded malleable iron (Fig. 14), are used in splitting unstratified stone. A row of holes is made with the drill (Fig. 15) on the line on which fracture is to be made; in each of these



FIG. 15.—Drills.

holes two feathers are inserted and the plugs are driven in between them. The plugs are then gradually driven home by light blows of the hand hammer on each, in succession until the stone splits."

**44. Methods of Finishing the Surfaces.**—"All stones used in building are divided into three classes, according to the finish of the surface, viz.:

- "1. Rough stones that are used as they come from the quarry.
- "2. Stones roughly squared and dressed.
- "3. Stones accurately squared and finely dressed.

"In practice the line of separation between them is not very distinctly marked, but one class merges into the next.

"*Unsquarred Stones.*—This class covers all stones which are used as they come from the quarry, without other preparation than the removal of very acute angles and excessive projections from the figure. The term *backing*, which is often applied to this class of



stone, is inappropriate, as it properly designates material used in a certain relative position in the wall, whereas stones of this kind may be used in any position.

“*Squared Stones*.—This class covers all stones that are roughly squared and roughly dressed on beds and joints. The dressing is usually done with the face hammer or axe, or, in soft stones, with the tooth hammer. In gneiss, it may sometimes be necessary to use the point. The distinction between this class and the third lies in the degree of closeness of joints. Where the dressing on the joints is such that the distance between the general planes of the surfaces of adjoining stones is  $\frac{1}{2}$  inch or more the stones properly belong to this class.

“Three subdivisions of this class may be made, depending on the character of the face of the stones.

“(a) *Quarry-faced* stones are those whose faces are left untouched as they come from the quarry.

“(b) *Pitch-faced* stones are those on which the arris is clearly defined by a line beyond which the rock is cut away by the pitching chisel, so as to give edges that are approximately true (Fig. 16).

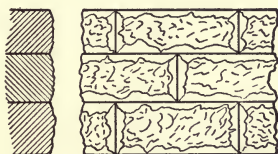

FIG. 16.—Pitch-faced Squared Stone.

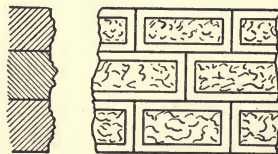

FIG. 17.—Drafted Stone.

“*Drafted Stones* are those on which the face is surrounded by a chisel draft, the space within the draft being left rough (Fig. 17). Ordinarily, however, this is done only on stones in which the cutting of the joints is such as to exclude them from this class.

“In ordering stones of this class, the specifications should always state the width of the bed and end joints which are expected, and also how far the surface of the face may project beyond the plane of the edge. In practice, the proportion varies from 1 to 6 inches. It should also be specified whether or not the faces are to be drafted.

“*Cut Stones*.—This class covers all squared stones with smoothly dressed beds and joints. As a rule, all the edges of cut stones are drafted, and between the drafts the stone is smoothly dressed. The face, however, is often left rough where the construction is massive.

“In architecture, there are a great many ways in which the faces

of cut stone may be dressed, but the following are those which will usually be met with in engineering work.

“*Rough-pointed*.—When it is necessary to remove an inch or more from the face of a stone, it is done by the pick or heavy point until the projections vary from  $\frac{1}{2}$  inch to 1 inch. The stone is then said to be rough-pointed. (Fig. 18.)

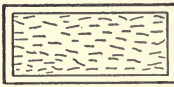

FIG. 18.—Rough-pointed.

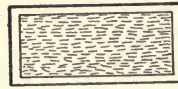

FIG. 19.—Fine-pointed.



“*Fine-pointed*.—If a smoother finish is desired, rough-pointing is followed by fine-pointing, which is done with a fine point. Fine-pointing is used only where the finish made by it is to be final, and never as a preparation for a final finish by another tool.

“*Crandalled*.—This is only a speedy method of pointing, the effect being the same as fine-pointing, except that the dots on the stone are more regular. The variations of level are about  $\frac{1}{8}$  inch, and the rows are made parallel. When other rows at right angles to the first are introduced, the stone is said to be cross-crandalled.

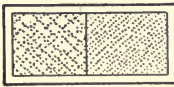

FIG. 20.—Crandalled.

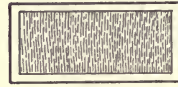

FIG. 21.—Axed or Pean-Hammered.



“*Axed or Pean-Hammered and Patent-Hammered*.—These two vary only in the degree of smoothness of the surface which is produced. The number of blades in a patent hammer varies from six to twelve to the inch; and in precise specifications, the number of cuts to the inch must be stated, such as 6-cut, 8-cut, 10-cut, 12-cut. The effect of axing is to cover the surface with chisel marks, which are made parallel as far as practicable. Axing is a fine finish. (Fig. 21.)

“*Tooth-axed*.—The tooth-axe is practically a number of points, and leaves the surface of the stone in the same condition as fine-pointing. It is usually, however, only a preparation for bush-hammering, and the work is done without regard to effect, as long as the surface of the stone is sufficiently leveled.

“*Bush-hammered*.—The roughness of the stone is pounded off by the bush hammer, and the stone is then said to be *bushed*. (Fig. 22.) This kind of finish is dangerous on sandstone, as experience has shown that sandstone thus treated is very apt to scale. In dressing limestone which is to have a bush-hammered finish, the usual sequence of operations is: (1) rough-pointing, (2) tooth-axing, (3) Bush-hammering.

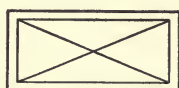
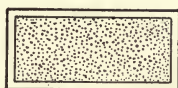

FIG. 22.—Bush-Hammered.

FIG. 23.—Diamond Panel.

“*Rubbed*.—In dressing sandstone and marble, it is very common to give the stone a plane surface at once by the use of the stone saw. Any roughnesses left by the saw are removed by rubbing with grit or sandstone. Such stones therefore have no margins. They are frequently used in architecture for string courses, lintels, door-jams, etc., and they are also well adapted for use in facing the walls of lock-chambers and in other locations where a stone surface is liable to be rubbed by vessels or other moving bodies.

“*Diamond Panels*.—Sometimes the space between the margins is sunk immediately adjoining them, and then rises gradually until the four planes form an apex at the middle of the panel. In general, such panels are called diamond panels, and the one just described (Fig. 23) is called a sunk diamond panel. When the surface of the stone rises gradually from the inner lines of the margins to the middle of the panel, it is called a raised diamond panel. Both kinds of finish are common on bridge-quoins and similar work. The details of this method should be given in the specifications.”

The following classification of the surface finish for stone used in masonry is given by the American Railway Engineering Association:<sup>1</sup>

*Dressing*.—The finish given to the surface of stones or concrete.

*Smooth*.—Having surface the variations of which do not exceed  $\frac{1}{16}$  inch from the pitch line.

*Fine-Pointed*.—Having irregular surface, the variations of which do not exceed  $\frac{1}{4}$  inch from the pitch line.

*Rough Pointed*.—Having irregular surface, the variations of which do not exceed  $\frac{1}{2}$  inch from the pitch line.

<sup>1</sup> Manual, American Railway Engineering Association, 1915.



*Scabbled*.—Having irregular surface, the variations of which do not exceed  $\frac{3}{4}$  inch from the pitch line.

*Rock-Faced*.—Presenting irregular projecting face, without indications of tool mark.

**45. Cutting by Machinery.**—In large yards and large building operations much of the shaping and dressing of stone is done by machinery. Portable machines using pneumatic tools are frequently employed, such as pneumatic hammers, drills, and chisels, which dress the stone in much the same manner as hand tools. The machines commonly employed also include saws adapted to all classes of stone—cutters for rough surfacing, planers for more accurate surfacing, and rubbing machines for grinding and polishing. The details of these machines and the character of the tools used with them vary with the nature of the stone to be worked.

In dimension stone and trimming work, drawings and dimensions for shaping the stones are provided, and the stones are usually cut at the yard and shipped to the point of use ready to place.

#### ART. 12. WALLS OF STONE MASONRY

**46. Classification of Masonry.**—Stone work is commonly divided into two general classes; *ashlar* and *rubble*, depending upon the degree of care exercised in cutting the stone and the closeness of the joints.

*Ashlar masonry* is that in which the joints are not more than  $\frac{1}{2}$  inch thick. The term *ashlar* is also sometimes extended to include masonry of squared stones in which the joints are not so accurately dressed, but this is not usual.

Ashlar masonry may be divided according to the arrangement of the stones into:

*Coursed ashlar*, sometimes called *Range masonry* (Fig. 24), arranged in courses of uniform thickness.

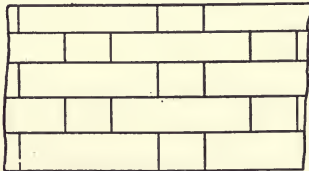

FIG. 24.—Coursed Ashlar.

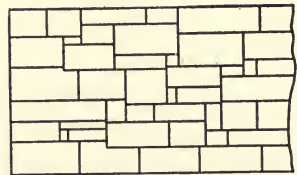

FIG. 25.—Broken Ashlar.

*Broken ashlar*, or *Random ashlar*, in which the stones are not arranged in courses (Fig. 25).

*Broken-coursed* or *Random-coursed ashlar*, in which broken ashlar work is arranged in more or less continuous courses, or masonry laid in parallel but not continuous courses.

In the best cut-stone work, as used by architects for public buildings in the cities, the joints may not be more than  $\frac{1}{4}$  inch thick, while in first-class masonry in important engineering construction joints from  $\frac{1}{4}$  to  $\frac{1}{2}$  inch are usually allowed. When the thickness of courses and length of stones in ashlar masonry are specified, the work is known as *dimension stone* masonry.

The exposed surfaces of ashlar masonry may be finished by any of the methods in the preceding section, and the masonry is frequently classified as pitch-faced ashlar, drafted-stone ashlar, or cut stone masonry, which includes all of the more accurate methods of dressing; pointing, bush-hammering, axing, etc. Pitch-faced and drafted-stone work is often called *rock-faced* ashlar.

*Rubble masonry* is that which is not dressed or laid with sufficient accuracy to be classed as ashlar, and may include stones roughly squared or those of irregular shapes.

Rubble masonry is usually uncoursed, but sometimes is leveled off into courses at specified heights, and is then known as *coursed rubble*. Fig. 26 shows the face of a wall of ordinary uncoursed rubble.



FIG. 26.—Uncoursed Rubble.



FIG. 27.—Random Rubble.

Fig. 27 shows a type of rubble work sometimes used in building construction, in which hammer-dressed joints are more accurately fitted on the face of the wall. Joints  $\frac{1}{2}$  to  $\frac{3}{4}$  inch may be used in such work. This is sometimes called "Russian Bond" and is usually rock faced work.

*Dry Masonry*.—Masonry of rough stone without the use of mortar is sometimes employed and is known as dry masonry. Such walls are frequently used for railway culverts and similar purposes. When stone is roughly placed about the bases of piers or abutments, or on the banks of streams to prevent erosion, it is commonly called *riprap*.

*Squared-Stone Masonry* is a term frequently used to indicate a class of masonry between ashlar and rubble. When this classification is used, it commonly includes masonry of squared stones, with joints from  $\frac{1}{2}$  to 1 inch thick, and the term rubble is limited to the use of irregular and unsquared material.

*Trimings.*—In architectural work, an additional classification is sometimes employed to designate stone used for special purposes, such as moldings, sills, caps, etc. These usually require cutting to specified dimensions and close joints.

**47. Parts of a Masonry Wall.**—The exposed surface of a masonry wall is called its *face*, while the interior surface is known as the *back* of the wall.

*Batter* is the slope of the surface of a wall, stated as a ratio of horizontal to vertical dimension. The walls of buildings usually have no batter. Retaining walls, bridge piers, and other heavy structures for carrying loads, are commonly given a batter on the face. This gives an appearance of strength and stability to the wall.

*Coping* is a course of stone on top of the wall to protect it and give a finished appearance. The coping usually projects a few inches over the surface of the wall.

*Courses.*—A horizontal layer of stones in the wall is called a course, the arrangement of courses in a wall being determined by the character of the material and the appearance desired. When the stone may be readily obtained in blocks of uniform thickness an arrangement in courses, with the thickest courses at the bottom, gives an appearance of stability, and is common practice in engineering structures. In architectural work, the arrangement of courses may be made to accord with other features of the design of the structure.

*Facing and Backing.*—The stones which form the face of the wall are called facing, while those forming the back of the wall are called backing. In the construction of walls, the facing and backing are commonly of different classes of masonry. An ashlar facing is frequently joined to a rubble or concrete backing.

In heavy walls the masonry of the interior of the walls, between the facing and backing, is known as filling, and this may sometimes be different from either the facing or backing. In constructing walls, the facing and backing should always be well bonded, so that the whole acts together in supporting loads or resisting pressures.

*Headers and Stretchers.*—A stone whose greatest dimension lies perpendicular to the face of the wall is called a header; one whose greatest dimension is parallel to the face of the wall is a stretcher.



The *bond* of the masonry in the wall is secured by proper arrangement of headers and stretchers. The vertical joints in adjoining courses should not be too nearly in the same plane. A stone in any course should break joints with the stones in the course below by a distance at least equal to the depth of the course. The strongest bond is obtained by using an equal number of headers and stretchers in the face of the wall, a header being placed over the middle of each stretcher as shown in Fig. 24.

In the use of coursed ashlar facing, the rubble filling and backing is usually also coursed at the same height as the ashlar. Sometimes in massive work the filling may be constructed of irregular uncoursed rubble. Usually, however, concrete would be used in such work instead of rubble.

In the walls of buildings with ashlar facings, the rubble backing is laid in courses with the ashlar and occasional headers are run through the wall as shown in Fig. 28. Brick backing is commonly used for such work and is usually preferable to rubble. (Fig. 29.)

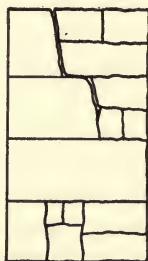

FIG. 28.

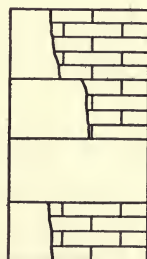

FIG. 29.

In building work, thin ashlar, 2 to 4 inches thick, is sometimes employed as a veneer on the exterior of a wall of rubble or brick; this is frequently done in marble buildings. The veneer is tied to the backing by iron clamps, and occasional belt courses of wider stones, extending 6 or 8 inches, into the filling give support to the ashlar.

*Dowels and Cramps.*—For the purpose of strengthening the bond where great resistance is required, dowels or cramps are often employed. A dowel is a straight bar of iron which enters a hole in the upper side of one stone and also a hole in the lower side of the stone above. A cramp is a bar of iron with ends bent at right angles to the length of the bar, the ends entering holes in the tops of adjacent stones.

**48. Setting Stonework.**—The layers of mortar between stones

are called *joints*. The horizontal joints are commonly called *beds* or *bed joints*.

The kind of mortar used in stonework depends upon the character of the work. In engineering structures, 1 to 2 or 1 to 3, Portland cement mortar is usually employed. Cement mortar stains many stones and care must be used in architectural work to prevent injury to appearance of the stone surface from this cause. This may often be effected by keeping the bed and joint mortar back from the face and using non-staining mortar for pointing. The bed joint of ashlar stones should be carefully dressed to a plane surface in order that the stone may bear evenly upon the bed. These joints are sometimes cut slightly concave to make them easier to set with close joints at the surface, which brings the loads upon the edges of the stone with danger of chipping the edges.

The vertical joints in ashlar facing should be carefully dressed to a depth of several inches from the face of the wall, but do not need to be accurately dressed the full depth of the stone. The backs of the ashlar stones may be laid as rubble without cutting. The arrangement of headers and stretchers in the rubble backing should be the same as in the ashlar facing to secure good bond throughout the wall.

*Placing Stone.*—All stones should be set in a full bed of mortar. The mortar bed should be prepared and the stone lowered upon it without disturbing stones already set. The stone must not be slid upon the bed so as to scrape away the mortar. Stones too large to be handled by one man are placed with a derrick, and are settled in place with light blows from a hammer. No cutting or trimming of stone after placing is allowable; the stone must be fitted to its place before spreading the mortar.

In the construction of rubble masonry, less care may be taken in the exact placing of the stones, but it is highly important that all the joints be completely filled. The strength of the masonry depends upon the stone having full bearing on the mortar at all points. The interstices between large stones in rough rubble are filled by driving stone chips into the mortar.

Stratified stones should always be set upon their natural beds, and not set on edge.

*Dimensions of Stones.*—A rule frequently used is that the width of a stone shall not be less than its height. The length of the stone, to avoid danger from cross-breaking, in well-laid masonry, may be about three times the thickness for the weaker stones, and about five times the thickness for the stronger ones.

*Pointing.*—In laying masonry it is not feasible to make well-filled, smooth joints at the face of the wall. It is usual, therefore, after the masonry has been laid, to clear out the joint to a depth of about an inch and refill with special mortar. This is called pointing the masonry. If, in placing the masonry, the mortar in the joints is not brought quite to the face of the wall, the labor of pointing may be somewhat lessened.

The joint is cleared and brushed out to a depth of at least an inch and well moistened before applying the pointing. The mortar is then applied with a small trowel, squeezed in, and smoothed with a special tool called a jointer, which is provided with an edge to form the kind of finish desired. There are a number of ways of finishing joints, of which the most common are shown in Fig. 30.

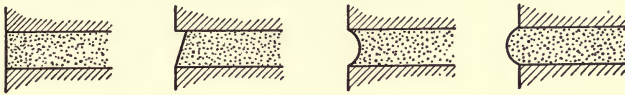

FIG. 30.—Methods of Finishing Joints.

The best pointing mortar is usually composed of Portland cement and sand, 1 to 1. Coloring matter is added when needed. The mortar is used quite dry, like damp earth. When the face of the stone would be stained by Portland cement, a putty made of lime, plaster of paris, and white lead is sometimes employed. Various non-staining cements are also available.

**49. Trimmings.**—In the erection of masonry structures, certain special parts are ordinarily required to be of cut stone, which must be of definite form and dimension. These trimmings have to do with the ornamentation of the structure, finishing about openings, or joining different types of construction.

*Water-tables* with sloping surfaces are used at the top of foundation walls, where they join the narrower upper walls.

*Copings, cornices, window sills,* and sometimes *belt-courses* project beyond the surface of the wall; they must have sufficient width to be firmly held in the wall, and to balance on the wall in laying. The projections should also have upper surfaces which slope away from the wall, and a drip (called the wash) underneath to cause water to drop off at the outer edge, the drip being made by cutting a groove on the under side of the stone.

When cut-stone trimmings are used for a brick wall, they should be dimensioned so that they will fit into the brickwork without splitting the brick.



Window sills just the width of the opening and not built into the wall at the ends are called *slip sills*, while those extending into the walls are called *lug sills*. The ends of lug sills are rectangular, the sloping surface of the sill being made the width of the opening. Lug sills should be bedded only at the ends to prevent cross-bending stresses due to the weight of the wall.

When stone lintels are used to span openings, care must be taken in selecting the stone, and making sure that it has the transverse strength necessary to carry the load. When necessary an angle bar or I-beam may be used to support the lintel, a recess being cut into the back of the stone for this purpose.

**50. Specifications for Stone Masonry.**—The following general requirements for stone masonry and special requirements for bridge and retaining wall masonry are recommended by the American Railway Engineers' Association in their Manual for 1915:

#### GENERAL REQUIREMENTS

*Stone.*—3. Stone shall be of the kinds designated and shall be hard and durable, of approved quality and shape, free from seams or other imperfections. Unseasoned stone shall not be used where liable to injury by frost.

*Dressing.*—4. Dressing shall be the best of the kind specified.

5. Beds and joints or builds shall be square with each other, and dressed true and out of wind. Hollow beds shall not be permitted.

6. Stone shall be dressed for laying on the natural bed. In all cases the bed shall not be less than the rise.

7. Marginal drafts shall be neat and accurate.

8. Pitching shall be done to true lines and exact batter.

*Mortar.*—9. Mortar shall be mixed in a suitable box, or in a machine mixer, preferably of the batch type, and shall be kept free from foreign matter. The size of the batch and the proportions and the consistency shall be as directed by the engineer. When mixed by hand the sand and cement shall be mixed dry, the requisite amount of water then added and the mixing continued until the cement is uniformly distributed and the mass is uniform in color and homogeneous.

*Laying.*—10. The arrangement of courses and bond shall be as indicated on the drawings, or as directed by the engineer. Stone shall be laid to exact lines and levels, to give the required bond and thickness of mortar in beds and joints.

11. Stone shall be cleansed and dampened before laying.

12. Stone shall be well bonded, laid on its natural bed and solidly settled, into place in a full bed of mortar.

13. Stone shall not be dropped or slid over the wall, but shall be placed without jarring stone already laid.

14. Heavy hammering shall not be allowed on the wall after a course is laid.

15. Stone becoming loose after the mortar is set shall be relaid with fresh mortar.

16. Stone shall not be laid in freezing weather, unless directed by the Engineer. If laid, it shall be freed from ice, snow, or frost by warming. The sand and water used in the mortar shall be heated.

17. With precaution, a brine may be substituted for the heating of the mortar. The brine shall consist of 1 pound of salt to 18 gallons of water, when the temperature is 32° F.; for every degree of temperature below 32° F., 1 ounce of salt shall be added.

18. Before the mortar has set in beds and joints, it shall be removed to a depth of not less than 1 inch. Pointing shall not be done until the wall is complete and mortar set; nor when frost is in the stone.

19. Mortar for pointing shall consist of equal parts of sand, sieved to meet the requirements, and Portland cement. In pointing, the joints shall be wet, and filled with mortar, pounded in with a "set-in" or calking tool and finished with a beading tool the width of the joint, used with a straight-edge.

#### BRIDGE AND RETAINING WALL MASONRY, ASHLAR STONE

*Bridge and Retaining Wall Masonry, Ashlar Stone.*—20. The stone shall be large and well proportioned. Courses shall not be less than 14 inches or more than 30 inches thick, thickness of courses to diminish regularly from bottom to top.

*Dressing.*—21. Beds and joints or builds of face stone shall be fine-pointed, so that the mortar layer shall not be more than  $\frac{1}{2}$  inch thick when the stone is laid.

22. Joints in face stone shall be full to the square for a depth equal to at least one-half the height of the course, but in no case less than 12 inches.

*Face or Surface.*—23. Exposed surfaces of the face stone shall be rock-faced, with edges pitched to the true lines and exact batter. The face shall not project more than 3 inches beyond the pitch lines.

24. Chisel drafts  $1\frac{1}{2}$  inches wide shall be cut at exterior corners.

25. Holes for stone hooks shall not be permitted to show in exposed surfaces. Stone shall be handled with clamps, keys, lewis, or dowels.

*Stretchers.*—26. Stretchers shall not be less than 4 feet long with at least one and a quarter times as much bed as thickness of course.

*Headers.*—27. Headers shall not be less than 4 feet long; shall occupy one-fifth of face of wall; shall not be less than 18 inches wide in face; and where the course is more than 18 inches high, width of face shall not be less than height of course.

28. Headers shall hold in heart of wall the same size shown in face, so arranged that a header in a superior course shall not be laid over a joint, and a joint shall not occur over a header; the same disposition shall occur in back of wall.

29. Headers in face and back of wall shall interlock when thickness of wall will admit.

30. Where the wall is 3 feet thick or less, the face stone shall pass entirely through. Backing shall not be permitted

*Backing.*—31a. Backing shall be large, well-shaped stone, roughly bedded and jointed; bed joints shall not exceed 1 inch. At least one-half of the backing stone shall be of the same size and character as the face stone and with parallel ends. The vertical joints in back of wall shall not exceed 2 inches. The interior vertical joints shall not exceed 6 inches.

Voids shall be thoroughly filled with concrete, or with spalls, fully bedded in cement mortar.

31b. Backing shall be of concrete, or of headers and stretchers, as specified in paragraphs 26 and 27, and heart of wall filled with concrete.

Paragraphs 31a and 31b are so arranged that either may be eliminated according to requirements.

32. Where the wall will not admit of such arrangement, stone not less than 4 feet long shall be placed transversely in heart of wall to bond the opposite sides.

33. Where stone is backed with two courses, neither course shall be less than 8 inches thick.

*Bond.*—Bond of stone in face, back, and heart of wall shall not be less than 12 inches. Backing shall be laid to break joints with the face stone and with one another.

*Coping.*—35. Coping stone shall be full size throughout, of dimensions indicated on the drawings.

36. Beds, joints and top shall be fine-pointed.

37. Location of joints shall be determined by the position of the bed plates as indicated on the drawings.

*Locks.*—38. Where required, coping stone, stone in the wings of abutments, and stone on piers, shall be secured together with iron cramps or dowels, to the position indicated on the drawings.

#### BRIDGE AND RETAINING WALL MASONRY, RUBBLE STONE

39. The stone shall be roughly squared and laid in irregular courses. Beds shall be parallel, roughly dressed, and the stone laid horizontal to the wall. Face joints shall not be more than 1 inch thick. Bottom stone shall be large, selected flat stone.

40. The wall shall be compactly laid, having at least one-fifth the surface of back and face headers arranged to interlock, having all voids in the heart of the wall thoroughly filled with concrete, or with suitable stones and spalls, fully bedded in cement mortar.

### ART. 13. STRENGTH OF STONE MASONRY

**51. Compressive Strength.**—Stone masonry varies widely in strength according to the character of the construction. The accuracy with which the joints are dressed, the strength of the mortar, the bonding of the masonry and size of blocks of stone are more important than the strength of the stone itself.

No experimental data are available which show the actual strength of masonry as used. The mortar has usually much less strength than the stone, and in some experiments on brick piers, the mortar seemed to squeeze out, causing the failure of the brick in tension. The loads to which masonry is ordinarily subjected are much less than its actual strength, but when heavy loads are being carried by piers or arches, it is frequently necessary to proportion the section to the load.



When the masonry is of cut stone with thin joints and Portland cement mortar, the strength of the masonry may be proportioned to the strength of the stone. For rubble with thick joints, the strength of the stone has no material effect upon the strength of the masonry.

The loads used in practice vary quite widely according to the views of the designers. Building laws of the various cities differ considerably in the loads allowed. The following may be considered as conservative values for the limits of safe loading:

*Cut Stone.*—Dressed stone, with joints not more than  $\frac{3}{8}$  inch in first class Portland cement mortar:

|                                    | Tons per<br>Square Foot. |
|------------------------------------|--------------------------|
| Granite . . . . .                  | 50 to 60                 |
| Hard limestone or marble . . . . . | 35 to 40                 |
| Sandstone . . . . .                | 25 to 30                 |

The siliceous sandstones may have larger values, while the soft limestones should be reduced.

For ashlar of good quality as commonly laid with  $\frac{1}{2}$ -inch joints in Portland cement:

|                           | Tons per<br>Square Foot. |
|---------------------------|--------------------------|
| Granite . . . . .         | 40 to 45                 |
| Limestone, hard . . . . . | 35 to 40                 |
| Sandstone . . . . .       | 25 to 30                 |

*Rubble.*—For masonry composed of large blocks of squared stone, 1-inch joints, in Portland cement mortar:

|                                    | Tons per<br>Square Foot. |
|------------------------------------|--------------------------|
| Sandstones or limestones . . . . . | 10 to 20                 |
| Granite . . . . .                  | 20 to 30                 |

Uncoursed rubble:

|                            |        |
|----------------------------|--------|
| In cement mortar . . . . . | 5 to 8 |
| In lime mortar . . . . .   | 3 to 5 |

For an ashlar pier whose height exceeds ten times, or a rubble pier whose height exceeds five times, its least lateral dimension, these figures should be reduced. Piers of small dimensions carrying heavy loads should always be of ashlar. Rubble should not be used for less thicknesses than 20 to 24 inches when it is necessary to develop the full strength of the masonry.

Failures of masonry most frequently occur through defective foundation or workmanship. Masonry, to develop its full strength,

must always be adequately supported, so that unequal pressures are not produced through settlement.

*Weight of Masonry.*—In determining loads, it is usually necessary to estimate the weight of masonry. This depends upon the specific gravity of the stone and the closeness of the joints. The following table gives approximate weights for the different classes of stone masonry:

|                                     | Pounds per<br>Cubic Foot. |
|-------------------------------------|---------------------------|
| Limestone, ashlar . . . . .         | 155 to 165                |
| Limestone, squared rubble . . . . . | 145 to 150                |
| Limestone, rough rubble . . . . .   | 135 to 140                |
| Granite, ashlar . . . . .           | 165 to 170                |
| Granite, squared rubble . . . . .   | 155 to 160                |
| Sandstone, ashlar . . . . .         | 135 to 150                |
| Sandstone, rubble . . . . .         | 120 to 140                |

**52. Capstones and Templets.**—When loads are to be transferred from the ends of beams or columns to masonry walls or piers, bearing blocks may be necessary properly to distribute the loads over the surface of the masonry. When used under a column or post, these blocks are called *capstones*; when used in walls to carry the ends of beams, they are *templets*.

In placing bearing blocks, the loads should always be centered on the top of the block, if possible, so as to produce uniform pressure upon the masonry below; in all cases; the center of pressure must be within the middle third of the base to avoid a tendency to open the joint between the bearing block and the masonry. In Fig. 31,

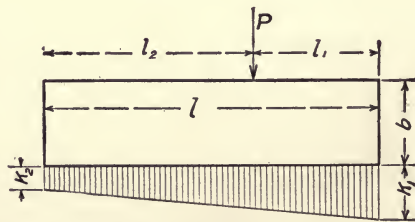

FIG. 31.

- let  $P$  = the vertical load at center of pressure;  
 $k_1$  = the pressure at edge nearest the center of pressure;  
 $k_2$  = the pressure at edge farthest from center of pressure;  
 $l$  = the length of stone;  
 $x$  = distance from middle of block to center of pressure;

$l_1$  = distance from nearest edge to center of pressure;  
 $l_2$  = distance from farthest edge to center of pressure;  
 $b^2$  = width of block. Then,

$$k_1 = \frac{4Pl - 6Pl_1}{bl^2} = \frac{Pl + 6Px}{bl^2},$$

and

$$k_2 = \frac{4Pl - 6Pl_2}{bl^2} = \frac{Pl - 6Px}{bl^2}.$$

When  $x=0$ ,  $l_1=l/2$  and  $k_1=k_2=P/lb$ . When  $x=l/6$ ,  $l_1=l/3$ ,  $k_1=2P/lb$  and  $k_2=0$ . If  $x$  becomes greater than  $l/6$ ,  $k_2$  is negative and a tension will be developed in the joint or it will open.

In designing a bearing block,  $k_1$  must not be greater than the safe load for the masonry. The load is commonly brought on top of a bearing block through an iron plate, which should have such area that the pressure will not be more than one-tenth to one-twelfth of the crushing strength of the stone. The bearing block must have sufficient thickness not to break under the transverse load imposed by the upward pressure of the masonry.

In designing a templet which is to be built into a wall, the weight of wall resting on the top of the templet must be included in determining the pressure on its base.

**53. Lintels and Corbels.**—A stone lintel is a beam of stone spanning an opening in a wall. The strength of a lintel is determined by the ordinary beam formulas. The safe modulus of rupture may be taken at about one-twelfth to one-tenth of the ultimate modulus for the stone. Mean values of the safe modulus of rupture are about as follows: granite, 180 lbs./in.<sup>2</sup>; Limestone, 150; marble, 130; sandstone, 120 lbs./in.<sup>2</sup>. There are, however, certain tough sandstones, specially adapted to this use, which may be used with modulus of 250 to 300 lbs./in.<sup>2</sup>

Beams carrying live loads should not rest upon stone lintels. When the load upon a lintel is a solid masonry wall, it is common to assume that the masonry may arch over the opening, so that the actual weight upon the lintel is only that of a triangle whose height is about three-quarters of the span. This assumes that the lintel will yield somewhat, and be relieved of stress before reaching the maximum load. It is quite possible that in well-built masonry, with cement mortar, the lintel might be removed without the wall above yielding at all. If, however, there is no yielding of the lintel, the pressure upon its upper surface may be the same as at any other point in the same horizontal plane of the wall.



A *corbel* is a block of stone extending beyond the surface of a wall or pier for the purpose of carrying the end of a beam or an overhanging wall, see Fig. 32. The overhang of the corbel is a cantilever beam, which must have sufficient section at the surface of the wall to resist the bending moment due to the load. The corbel must extend sufficiently into the wall, to give a resultant pressure within the middle third of the base of the corbel ( $R = P + W$ ), as in the case of bearing blocks.

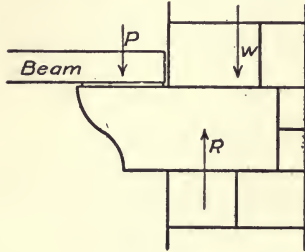

FIG. 32.—Corbels.

Double corbels may be used when necessary, each being separately treated in determining strength. When weight of wall above ( $W$ ) is lacking, the corbel must be anchored to the wall below by steel ties.

#### ART. 14. MEASUREMENT AND COST

**54. Methods of Measurement.**—In engineering work it is usual to estimate stone masonry in cubic yards of actual masonry. When parts of the work are of special character, requiring cut-stone finish, special prices per cubic yard may be given, or the additional costs of the cut surfaces are paid for by the square yard.

In architectural work masonry is measured by the cubic yard or by the perch. A perch may be  $16\frac{1}{2}$ , 22, or 25 cubic feet, according to the custom of the locality in which the masonry is constructed. In the use of the perch as a unit, it is advisable to state the number of cubic feet to be considered a perch.

In building work it is common to take outside measurements of walls, thus including the corner masonry twice; it is also customary to measure small openings as solid wall. Commonly openings less than 70 square feet are not deducted. In some cases allowances are made for openings more than 6 feet wide. Customs differ in different parts of the country, and it is necessary to know the local usage, unless the method of measurement is stated.

**55. Cost of Stone Masonry.**—So many items are included in the cost of masonry and these items vary so widely in different localities that it is not feasible to give any definite values to the costs of different kinds of work. The items of cost include the price of the rough stone at the quarry, the transportation to place of use,

dressing joints and faces of stone, mortar for joints, setting the stonework, and pointing the joints.

Rough stones at the quarry are commonly classified into rubble or small stone and dimension stone. Rubble stone includes the more irregular stones and blocks suitable for small ashlar. Dimension stone includes all stone required to be of particular sizes and blocks of large dimensions and definite thicknesses, as required for coursed ashlar. These classes vary according to the kinds of stone in the quarry and the specifications to be met by the stone.

Rubble stone is commonly sold by the ton free on board cars at point of delivery. Prices for rubble stone delivered have varied in various localities from \$0.50 to \$2 per ton, when wages of quarrymen were about \$4.50 per day and common labor \$1.50. The cost is largely a matter of locality. A ton of rubble stone may lay from about 16 to 22 cubic feet of masonry.

Dimension stone and ashlar in the rough may cost from \$0.50 to \$1.25 per cubic foot for limestone or sandstone and \$0.75 to \$1.50 per cubic foot for granite, according to quality and location.

*Cost of Stone Cutting.*—The cost of cutting ashlar depends upon the hardness of the stone and the shape in which the blocks are received. Some stratified stones require almost no dressing on the bed joints, while other stones need every joint dressed from an irregular surface. With wages of stone cutters at \$5 per day, the following may be considered average costs per square foot for cutting to  $\frac{1}{2}$ -inch joints; granites, 27 to 35 cents; hard sandstones and limestones, 20 to 30 cents; soft stones, 16 to 22 cents. Costs of peculiar face cuttings and of trimmings are so special to particular stones that they are of little value for general use. Sills, lintels, water-tables, and copings are usually sold by the lineal foot.

The cost of sawing and machine dressing is usually much less than that for hand dressing, and varies with the way the stone is handled and the organization of the yard.

*Mortar Required.*—The amount of mortar needed in rubble masonry may vary from about 15 to 35 per cent of the volume of the masonry. Rubble of squared stones with joints 1 inch thick will ordinarily require 15 to 20 per cent, according to the sizes of the stones. For random rubble, stratified stones with flat beds require less than irregular stones. In the use of irregular rubble stones, the careful use of spalls in the larger joints reduces the amount of mortar materially, with saving in cost.

The amount of mortar needed for ashlar work depends upon the sizes of the stones. Ordinary ashlar with  $\frac{1}{2}$ -inch joints in courses

12 to 20 inches thick requires 4 to 7 per cent of mortar; random ashlar with smaller stones will require more, while with large blocks and thinner joints less will be required.

*Cost of Laying Masonry.*—The cost of setting stone varies with the size of the job, the organization of the work, and the skill of the masons, as well as with the character of the work itself. In ordinary rubble or squared-stone work, such as cellar walls or light retaining walls, a mason should lay a cubic yard of masonry in three or four hours. A helper to two masons or a helper to each mason, according to convenience of work, being required to supply stone and mortar. With masons at 50 cents an hour and helpers at 20 cents, this would cost from \$1.80 to \$2.80 per cubic yard. In large work, where stone is handled by derricks, and rubble constructed of large blocks, the cost of placing the stone is frequently reduced to \$0.85 to \$1.25 per cubic yard. The cost of setting ordinary ashlar varies from about \$3 to \$5 per cubic yard for limestone and sandstone, and from \$6 to \$9 for granite.

The total cost of masonry in place, made up by so many varying items, necessarily varies within wide limits. Ordinary rubble at prices which have existed within the past few years (previous to the War), averages in cost from \$5 to \$7 per cubic yard. Rubble in heavy construction, usually granite, where the stone was quarried on the work and handled by machinery, has run from \$5 to \$11 per cubic yard. Sandstone and limestone bridge masonry, with ashlar facings and rubble backing and filling, usually varies from about \$8 to \$14 per cubic yard.

Gillette's "Handbook of Cost Data" gives a number of detailed statements of costs of stone masonry. Such costs vary in about the same ratio as the pay of labor employed. The unsettled state of prices and labor costs since the War make it impracticable to give costs based upon present prices.



## CHAPTER IV

### BRICK AND BLOCK MASONRY

#### ART. 15. BUILDING BRICKS

**56. Clay and Shale Bricks.**—The cheapness, ease of construction, and durable qualities of good brick masonry make it one of the most desirable materials for general structural work. It is not as largely used in engineering work as stone or concrete, but in building construction it is very extensively employed. The qualities of clay bricks vary widely according to the character of the clay and methods of manufacture, and care must be taken in selection of material in order to secure good results.

*Composition of Clay Bricks.*—Clay consists primarily of silicate of alumina. Common clays also usually contain certain percentages of iron oxide, magnesia, lime, and alkalies. These are known as fluxes, having the effect, when in considerable quantities, of making the clay fusible. Fire clays contain a low percentage of fluxes, and withstand a high degree of heat without fusing.

Sandy clays contain high proportions of silica in an uncombined state, a factor which, if not in excess, is of value, tending to give stability to the form of the brick. Sand is commonly added to plastic clays for this purpose.

The color of the brick is mainly dependent upon the amount of iron oxide present in the clay. The color varies from white, through buff to red as the percentage of iron oxide increases. The presence of iron oxide is also of value in adding strength and hardness to the brick.

Lime, when present in appreciable quantities, must be finely divided and uniformly distributed through the clay. If in lumps, the slaking of the lime, subsequent to burning, may cause the brick to become distorted and cracked. When in excess, lime neutralizes the color effect of the iron oxide, making the bricks lighter in color, buff or yellow colors being sometimes due to this cause.

Excess of alumina usually makes the clay very plastic and causes it to shrink and crack in drying.

*Physical Properties.*—The physical properties of clay are of more importance than the chemical composition.

Plasticity is one of the important properties of clay for brick making, as it permits the clay to be worked into a plastic mass, and to be molded into the desired form. Clay shrinks in drying and also in burning, very plastic clay shrinking more than that less plastic. Sand is frequently mixed with clay to reduce excessive shrinkage. The degree of plasticity is sometimes controlled by mixing clays which differ in this respect.

When subjected to high heat, clay gradually becomes soft and fuses together, and as the heat is increased the softening and shrinkage progresses until the material finally melts sufficiently to lose its shape. The temperature required for burning varies widely with different clays, and the degree of burning given to brick depends upon the kind of product desired and the fusibility of the clay.

*Manufacture.*—There are three methods in use for forming the brick. They are known as the *soft-mud*, the *stiff-mud*, and the *dry-press* methods.

The *soft-mud* process consists in pulverizing the clay or shale and tempering it with water to the consistency of soft mud. This paste is then pressed into wooden molds, which are usually sanded on the surface to prevent the clay sticking, thus giving the brick five sanded surfaces.

The *stiff-mud* process consists in mixing the pulverized clay or shale with sufficient water to form a stiff paste, capable of retaining its form, which is then forced through a die, resulting in a bar of the section of the brick. The bar is then cut into bricks by wires. These bricks may be either side cut or end cut.

*Dry-press* bricks are made by pressing pulverized clay containing a small amount of moisture into steel molds, a method used to secure bricks with smooth faces and sharp edges for face brick.

*Repressed bricks* are made by putting bricks made by the soft-mud or stiff-mud methods into presses and subjecting them to high pressure. The purpose is to give the brick more perfect form and sometimes to imprint a design upon the surface.

Bricks made by the wet method must be dried before being placed in the kiln. In some yards this is accomplished by exposing the molded bricks to the air on floors or racks, while in the larger plants the drying is done more rapidly in dryers using artificial heat.

The burning is accomplished either in temporary kilns, built of the brick to be burned, or in permanent kilns arranged usually with fire boxes on the outside and a downdraft and intended to give

uniform heat throughout the kiln. This cannot be fully accomplished and all of the brick will not be perfectly burned. The degree of burning received by brick in temporary kilns depends upon the position in the kiln. They must be sorted after burning into various shades, varying from the light underburned to the dark arch brick.

Good bricks may be made by any of the methods of manufacture, provided the material is carefully handled and the burning properly regulated. The differences due to method used are mainly those of the form and appearance of the brick. Dry-press brick are usually somewhat softer and weaker than stiff-mud brick of equally good material.

### CLASSIFICATION OF BRICK

Bricks used in structural work may be classified as follows:

*Common bricks* are those used for ordinary brickwork, where appearance is not of special importance. They are burned at moderate temperatures. The best, well-burned common bricks are known as *hard* or *cherry* bricks, or sometimes as *stock* bricks. Those next the fire and heavily burned are known as *clinker* or *arch* bricks. Those from the underburned portion of the kiln are known as *salmon*, *pale* or *soft* bricks. The relative proportions of each kind in a kiln vary with the material and the skill used in burning.

*Pressed, face or front* bricks are those made with greater care, so as to secure uniformity of form and color. They are used for facing walls of common brick and where appearance is important, and are usually dry-pressed or re-pressed brick.

Vitrified bricks are made from a more refractory clay and burned at a high heat to the point of vitrification, so that considerable softening and shrinkage occurs, though the brick still hold its shape. These bricks are commonly made in larger sizes than common bricks, called *paving blocks*, and are used in street pavements. They are also frequently used in building construction, where obtainable at moderate prices. Blocks too lightly burned for use in pavements often make good material for building construction.

Fire bricks are made from clay which is lacking in fluxing ingredients. They are usually light in color, on account of the absence of iron oxide, and are used when high temperatures are to be resisted.

*Enameled* bricks are made by coating the surface of pressed or re-pressed bricks before burning with a slip, which will burn to the proper color, and covering with a glaze. The enamel is usually applied to a single surface of a brick.



The following designations are also frequently employed:

*Sewer bricks* are those common bricks which are so hard burned as to be practically non-absorbent of moisture, and are commonly used for lining sewers.

*Compass bricks* are shorter on one edge than the other, for use in circular walls.

*Feather-edge bricks* are made wedge shaped, for use in arches.

*Furring bricks* are those having a surface grooved for plastering.

Ornamental bricks are those having designs stamped in relief upon their faces, or bricks of special forms intended for use in making an ornamental surface design.

#### PROPERTIES OF CLAY AND SHALE BRICK

Good building brick should show a uniform compact structure without laminations. They should have plane, parallel faces and sharp edges, and should not show kiln marks on their edges.

The dry-pressed and re-pressed bricks are usually smoother and more accurate in shape than those made by the soft-mud or stiff-mud processes, their density and strength being largely dependent upon the degree of burning and the shrinkage in the kiln. The underburned, salmon bricks are porous and weak, and are usually employed only where strength is not important and in unexposed positions. The well-burned cherry or hard bricks are the best building brick. The overburned clinker bricks are more dense and absorb less water, but may be brittle, and are frequently distorted in shape. The overburned and distorted bricks are sometimes used by architects for special exterior designs with very good effect.

Vitrified bricks, as manufactured for use in paving, are superior in strength and density to common bricks. They frequently show kiln marks on one side, due to softening in the kiln. A clay for making vitrified brick must burn at high temperatures and have considerable range of temperature between the point of incipient fusion and the point of vitrification. It is difficult to maintain the temperature uniformly, so as to burn a large portion of the bricks to the right degree, unless the range of temperature is considerable.

**57. Sand-lime Bricks.**—Bricks made of sand cemented with lime have been used in a small way for many years. These bricks, as formerly made, were molded and allowed to harden by standing in the air, or in an atmosphere rich in carbon dioxide ( $\text{CO}_2$ ). Bricks of this kind are virtually composed of ordinary lime mortar, but with less lime, and are called *mortar bricks*. They depend, like

lime mortar, upon the formation of carbonate of lime for their hardening, and are weak and of little value as brick, although some structures of such materials have proven substantial and durable.

In 1881 Dr. Michaelis of Berlin patented a process of hardening mixtures of lime and sand by the use of steam at high pressure. He discovered that, in the presence of steam at high temperature, the lime combines with a portion of the silica of the sand, forming a silicate of lime, which acts as a cementing medium. This silicate is formed upon the surfaces of the grains of sand and binds the sand into a single hard block.

About fifteen years after Michaelis took out his patent, the manufacture of sand-lime bricks was begun in Germany on a commercial scale, and soon developed into a considerable industry. In 1901 the first plant was opened in the United States, and the growth of the industry in this country was also very rapid.

*Manufacture.*—In the manufacture of sand-lime bricks, four operations are essential:

- (1) The lime must be completely slaked.
- (2) A very uniform mixture of the lime and sand must be obtained.
- (3) The material must be formed into bricks under high pressure.
- (4) The bricks must be subjected to the action of steam at high pressure for several hours.

The methods employed in different plants for performing these operations vary considerably, depending upon the character and condition of the materials employed.

*Hydrated-lime Process.*—In this process the lime is first slaked to a powder, or a putty, and then mixed with the sand and pressed. The lime may be slaked by any of the methods ordinarily employed in the manufacture of hydrated lime, or it may be reduced to a paste by the use of an excess of water. It is easier to obtain a uniform mixture of the lime and sand when dry hydrated lime and dry sand are used and the necessary water added afterward. It may, however, be advantageous sometimes to use wet materials, and good results may be obtained by either method if the mixing be thorough and the lime uniformly incorporated in the sand.

*Caustic Lime Process.*—Caustic lime is sometimes pulverized and mixed with the sand before slaking. Enough water is then added to slake the lime and reduce the mixture to proper consistency for pressing. High-calcium lime, which slakes quickly, is necessary when this method is used, as sufficient time must be given for the complete slaking to take place before the mixture goes to the press. In some plants the mixture is placed in a silo and allowed to stand

for a few hours before pressing, in order to insure that no unslaked lime is left in the mixture when the brick is formed.

The caustic lime process is sometimes modified by grinding the lime with a portion of the sand to a fine powder, which is mixed with the remainder of the sand, and water added to slake the lime and wet the mixture. This is then placed in a silo for a sufficient period to allow the lime to become completely slaked before pressing. It is claimed that grinding the sand and lime together produces an intimate mixture and insures the complete combination during the steaming into silicate which forms the cementing medium of the brick. Grinding the lime and sand together reduces the lime to very fine condition and minimizes the danger from any unslaked particles of lime left in the mixture, and also fills the voids in the sand more completely, making a more dense brick.

*Molding.*—The bricks are formed in molds similar to those used for dry clay bricks, and are subjected to high pressure in molding.

*Hardening.*—After molding, the bricks are loaded upon cars and run into the steaming cylinders, where they are subjected to steam pressure of from 100 to 110 pounds per square inch for a period of six to ten hours, resulting in the combination of the lime with the silica into the cementing substance and binding the sand into a solid block. The brick continue to harden and gain in strength for a time after their removal from the steaming cylinder, as they gradually dry out.

*Materials.*—High-calcium lime seems preferable for this use, on account of this rapid action and the fine subdivision of its particles. Any good lime may, however, be used for the purpose if care be taken to insure that it be completely slaked.

The requirements for sand to be used in making sand-lime bricks are not essentially different from those for sand to be used in cement mortar. The graduation of sizes to give a dense material is desirable. The presence of more fine material seems to be needed, however, in order to secure a smooth and compact mixture, and to lessen the wear upon the molds, which may become an important item of cost. Coarse sands seem to give stronger brick, but fine sand produces brick with smoother surfaces.

*Properties of Sand-lime Brick.*—In strength and durability, sand-lime bricks do not differ materially from good average clay bricks. When of good quality they possess sufficient strengths for all the purposes for which building brick are ordinarily employed, and are



usually more dense, and absorb less water than common clay bricks.

Sand-lime bricks are usually very uniform in size and shape, and are commonly gray in color, the shade depending upon the sand used in manufacturing them, unless artificially colored.

**58. Cement Bricks.**—Bricks made of cement mortar or concrete are used in a number of localities. They are commonly made of mortar, about one part Portland cement to four parts of sand, or sometimes of a richer mortar, 1 to  $2\frac{1}{2}$  or 1 to 3, mixed with about an equal quantity of coarser material, varying from  $\frac{1}{4}$  to  $\frac{1}{2}$  inch in diameter.

These bricks are made by pressing in hand or power presses, a mixture as wet as is feasible to shape well in the press. About two weeks are required for hardening before the bricks can be used. The materials need to be carefully selected, and require the same properties as for mortar for use in masonry or concrete. The strength may vary considerably with the grading of the aggregate, the compression given to the blocks, and the moisture conditions under which the bricks are kept during the period of hardening, the greatest strength will result when they are kept warm and thoroughly dampened. The compressive strength at twenty-eight days should not be less than 1000 lb./in.<sup>2</sup>, and the absorption not more than 15 per cent.

Cement bricks are usually employed as face bricks. The appearance will depend upon the texture of the aggregates used and the method of finishing, which may be smooth or roughened by the use of brushes or acids. Color may be given to the bricks by the use of various mortar colors.

**59. Test for Building Brick.**—In determining the suitability of a brick for structural work, examination is commonly made of the material as to form and texture with reference to the particular needs of the work in hand. Tests for strength and absorption are sometimes included in specifications for important work, but there is no recognized standard to which such tests conform, and comparatively little data upon which to base a reasonable requirement.

*Form.*—For neat work, the bricks should be uniform in size with plane faces and sharp edges. Care in sorting is usually necessary with clay brick to secure uniformity of color and dimension in particular work.

*Texture.*—Good bricks should be uniform and compact in struc-

ture, should be sound and free from cracks, and the broken surfaces should be free from flaws or lumps. Clay brick should be thoroughly burned, and when struck with a trowel or another brick should give a clear ringing sound. Bricks which meet these requirements are usually suitable for all ordinary work.

In ordinary building work little care is usually given to inspection of the materials, and defective work frequently results from the use of poor bricks. Seriously defective bricks are so easily detected by inspection that there is usually no excuse for their inclusion in brickwork of good character.

A Committee of the American Society for Testing Materials has been for some time studying the matter of a standard specification and standard tests for building brick. They have suggested tentative methods for classification of brick and for making tests for absorption, compressive strength, and transverse strength.

The committee recommends that the standard sizes for building brick shall be  $2\frac{1}{4}$  by  $3\frac{7}{8}$  by 8 inches.

They also recommend the following classification of bricks:

(a) According to the results of the physical tests, the bricks shall be classified as vitrified, hard, medium, and soft bricks on the basis of the following requirements:

| Name of Grade.      | ABSORPTION LIMITS,<br>PER CENT. |                             | COMPRESSIVE STRENGTH,<br>(ON EDGE)<br>LB. PER SQ. IN. |                             | MODULUS OF RUPTURE,<br>LB. PER SQ. IN. |                             |
|---------------------|---------------------------------|-----------------------------|---|-----------------------------|--|-----------------------------|
|                     | Mean of<br>5 Tests.             | Individual<br>Maxi-<br>mum. | Mean of<br>5 Tests.                                   | Individual<br>Mini-<br>mum. | Mean of<br>5 Tests.                    | Individual<br>Mini-<br>mum. |
| Vitrified Brick.    | 5 or less                       | 6.0                         | 5000 or over  | 4000                        | 1200 or over                           | 800                         |
| Hard Brick. . . .   | 5 to 12                         | 15.0                        | 3500 or over  | 2500                        | 600 or over                            | 400                         |
| Medium Brick.       | 12 to 20                        | 24.0                        | 2000 or over  | 1500                        | 450 or over                            | 300                         |
| Soft Brick. . . . . | 20 or over                      | No Limit                    | 1000 or over  | 800                         | 300 or over                            | 200                         |

(b) The standing of any set of bricks shall be determined by that one of the three requirements in which it is lowest.

The methods proposed for making these tests are given in the Proceedings of the Society for 1919, Part 1, p. 543.

*Durability Tests.*—The durability of bricks under difficult weather conditions is one of their most valuable qualities. Tests are sometimes made of the effect upon bricks of freezing while in a saturated

condition. These tests have been made in various ways, usually by immersing the brick in water, then freezing and thawing it repeatedly, commonly twenty repetitions, and determining the loss of weight or of strength. Very soft, porous bricks may be disintegrated by such treatment; those of low absorption and good strength usually show but slight effect.

The Committee of the American Society for Testing Materials, in 1913, suggested a method for making this test. They have not, however, found it of sufficient value to include in their later specifications.

A test in which the brick is saturated with a solution of sodium sulphate, which is then allowed to crystallize in the pores of the brick, has sometimes been used, the results of this action being similar to those of freezing, but much more rapid and severe. A study of this method has been made for the Committee by Professor Edward Orton, Jr.<sup>1</sup> and it seems probable that it may become a standard method of testing brick. It has not yet been definitely formulated for use in specifications.

#### ART. 16. BRICK MASONRY

**60. Joints in Brickwork.**—In the construction of brick masonry, it is necessary that the joints between the bricks be filled with mortar, the purpose of which is to give a firm and even bearing to the bricks, so that the pressure upon them will be uniformly distributed. The mortar should also adhere to the bricks and bind them into a monolithic mass.

While thick joints usually make weaker masonry than those that are thin, it is desirable that the joint be as thin as it can readily be made. When attempts are made at too thin joints, they are apt to be imperfectly filled, and thus weaken the masonry. Joints in wall masonry of common brick, as used in building construction, are usually from  $\frac{1}{4}$  to  $\frac{3}{8}$  inch thick. It is common to specify the thickness of joints by stating the thickness for eight courses of brick. It is frequently required that the thickness of eight courses of brick masonry shall not exceed the thickness of eight courses of dry bricks by more than 2 inches. When pressed bricks are used for the face of a wall, the joints in the face are usually from  $\frac{1}{8}$  to  $\frac{3}{16}$  inch thick.

<sup>1</sup> Proceedings, American Society for Testing Materials, 1919, Part 1.



Pressed bricks, being smoother, may be laid to thinner joints with good effect. In heavy masonry as sometimes used in engineering work, the joints usually of cement mortar—are often  $\frac{1}{2}$  inch thick.

*Mortar for Brickwork.*—Lime mortar is more extensively used for ordinary brickwork in building construction than any other. Mixtures of lime and cement mortars in about equal quantities are coming largely into use. The cement materially increases the strength of the mortar and its adhesion to the brick, while the smoothness of the lime mortar is maintained. In important structures, where considerable strength is needed, it is common to use cement mortar with addition of 10 to 15 per cent of hydrated lime—a mixture which retains the strength of the cement but makes the mortar easier to work, and usually secures better work than would result from the use of cement alone. In engineering work, cement mortar is usually employed, but the mixture of hydrated lime with the cement is rapidly coming into use.

*Laying the Brick.*—In the construction of a brick wall the two outer courses are first laid, by spreading a bed of mortar where the brick is to be placed, and against the surface of the last brick laid, then shoving the brick horizontally into place so as to squeeze the mortar into the bottom of the vertical joint between the bricks. A bed of mortar is placed between the outside bricks and the filling bricks are shoved and pressed into place. Mortar is then slushed or thrown with some force into the upper part of the vertical joints to fill them completely.

Bricks should be thoroughly wet before being laid, in order to prevent the water being absorbed from the mortar by the brick. Good adhesion cannot be had between mortar and dry, porous bricks.

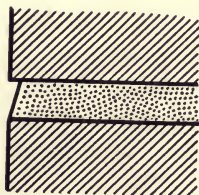

FIG. 33.—Weather Joint.

In finishing joints upon the face of the wall, a flush joint may be made by pressing back the mortar with the flat edge of the trowel. This is usually done upon interior walls. A weather joint may be made, as shown in Fig. 33, by using the point of the trowel held obliquely.

**61. Bond of Brickwork.**—Brickwork is always laid in horizontal courses, and lateral bond is secured by several different arrangements of the brick in the courses.

*Common Bond* is the bond most commonly used in the United

States, for walls of common brick. In this bond, one course of headers is used to four to six courses of stretchers on the face of the wall, as shown in Fig. 34.

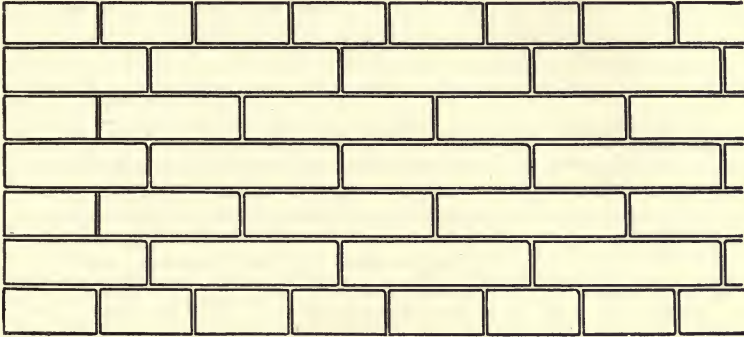

FIG. 34.—Common Bond.

In *Flemish Bond* (Fig. 35), alternate headers and stretchers are used in each course, each header being placed over the middle of the stretcher in the course below. Small closers are introduced next to the headers at the corners.

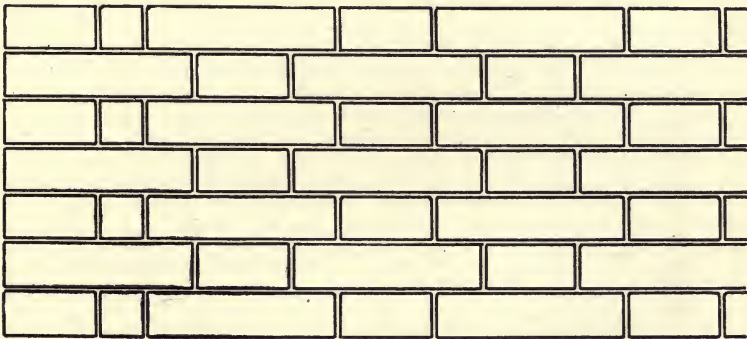

FIG. 35.—Flemish Bond.

*English Bond* consists of alternate layers of headers and stretchers (Fig. 36). This construction, like the Flemish bond, makes very strong work. English bond in which the alternate courses of stretchers break joints with each other is called *Cross English* bond.

*Hoop-iron Bond.*—This consists in placing pieces of hoop iron longitudinally in the joints to strengthen the bond, the ends of the iron being turned down into vertical joints.

*Pressed Brick Facing.*—In applying a facing of pressed bricks, it is quite common to lay all of the face bricks as stretchers. When this is done bond may be obtained by metal ties or by diagonal bond.

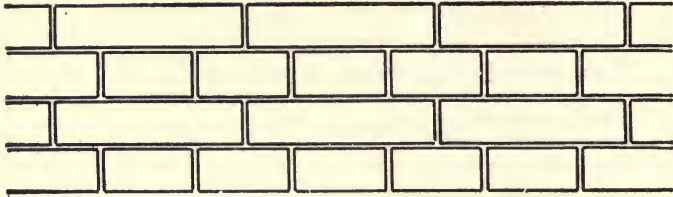

FIG. 36.—English Bond.

*Metal Ties* are sometimes used as shown in Fig. 37. When the joints in the face and backing cannot be brought to the same level, the metal tie may be bent, but this is not desirable, and frequent level joints should always be possible. These ties may consist of a thin piece of galvanized iron bent over a wire at the ends, or it may be a piece of galvanized wire bent into a loop at the ends to grasp the mortar.

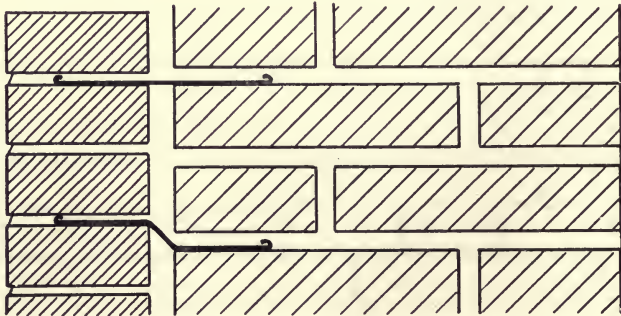

FIG. 37.—Metal Ties for Face Brick.

*Diagonal Bond* consists in breaking off the back corners of face bricks and inserting bricks diagonally to bond with the face brick.

These bonds are not very strong, and the face bricks are not considered as adding to the strength of the wall or carrying any load. Stronger work is obtained by using occasional courses of headers,



or courses of alternate headers and stretchers as in the Flemish bond. This is usually possible by using care in regulating the thickness of joints in the backing, even when the bricks are not of the same sizes.

*Hollow Brick Walls.*—For the purpose of providing air space in a wall to prevent the passing of moisture or changes of temperature through it, hollow construction is sometimes adopted. This consists in building a double wall with a narrow air space between the outer and inner portions.

It is necessary for proper strength that the two portions of the wall be bonded in some way, either by occasional headers which span the opening or by metal ties. The headers constitute a connection between the masonry of the two walls, and are sometimes objected to as likely to cause moisture to pass from one wall to the other. The metal ties may be provided with a drip at the middle which insures the complete isolation of the walls from each other. Such walls require more careful work and are more expensive to construct than solid walls. When loads are to be carried, one of the walls must be capable of bearing them.

**62. Strength of Brick Masonry.**—In tests which have been made on the crushing strength of brick piers, failure occurred by the lateral bulging of the piers. When pressure is applied longitudinally upon the pier, a lateral expansion normal to the direction of pressure results. This causes tension upon the brickwork and the pier yields through breaking the bricks in tension and pulling apart of joints. The transverse strength of the bricks may also be called into play when they are not bedded with perfect evenness—a fact proven by a series of tests on brick piers at the Watertown arsenal in 1907, in which bricks set on edge gave somewhat higher strengths than when laid flat. Piers in which the joints were broken at every third or sixth course gave slightly better results than those breaking joints at every course, as was also observed in piers tested in 1884.

The strength of brickwork depends upon the bond as well as upon the adhesion of the mortar and the strength of the bricks. In masonry to be subjected to heavy loads, careful attention should be given to the bonding of the work and to the complete filling of the vertical joints in laying the masonry.

The advantage of using strong mortar in such work is demonstrated by many tests made at Watertown arsenal and reported by the Ordnance Department of the United States Army in "Tests of Metals, etc." That the strength of brick masonry in piers is somewhat proportional to the strength of the bricks is also demonstrated by these tests.

A series of tests made by A. N. Talbot and D. A. Abrams at the University of Illinois Experiment Station in 1908 gives very interesting results. A summary of these results is given in Table VI.

TABLE VI  
SUMMARY OF TESTS OF BRICK COLUMN

| Average Values         |   |                                    |  |  |  |  |
|------------------------|---|------------------------------------|--|--|--|--|
| Ref.                   | Characteristics of Columns.   | Average Unit Load, lb. per sq. in. | Ratio of Strength of Column to Strength of Brick | Ratio of Strength of Column to Strength of "A" | Crushing Strength of 6-in. Mortar Cubes, lb. per sq. in. | Ratio of Strength of Column to Strength of Cubes |
| Shale Building Brick   |   |                                    |  |  |  |  |
| A                      | Well laid, 1:3 Portland cement mortar, 67 days.                       | 3365                               | .31  | 1.00   | 2870*  | 1.17   |
| B                      | Well laid, 1:3 Portland cement mortar, 6 months                       | 3950                               | .37  | 1.18   | ....   | ....   |
| C                      | Well laid, 1:3 Portland cement mortar, eccentrically loaded, 68 days. | 2800                               | .26  | .83  | ....   | ....   |
| D                      | Poorly laid, 1:3 Portland cement mortar, 67 days.                     | 2920                               | .27  | .87  | 2870*  | 1.05   |
| E                      | Well laid, 1:5 Portland cement mortar, 65 days.                       | 2225                               | .21  | .66  | 1710   | 1.30   |
| F                      | Well laid, 1:3 natural cement mortar, 67 days.                        | 1750                               | .16  | .52  | 305  | 5.75   |
| G                      | Well laid, 1:2 lime mortar, 66 days.....                              | 1450                               | .14  | .43  | ....   | ....   |
| Underburned Clay Brick |   |                                    |  |  |  |  |
| H                      | Well laid, 1:3 Portland cement mortar, 63 days.                       | 1060                               | .27  | .31  | 2870*  | .37  |

\* Average value based on 1:3 tests of 1:3 Portland cement mortar cubes sixty days old.

In the testing of brick piers it has been found that the initial yielding of the pier usually occurs at about one-half the breaking load. The safe load should be taken at not more than one-tenth to one-twelfth of the breaking load, on account of the many elements of uncertainty concerning the actual strength, chances for defective work, etc.

A committee of engineers and architects recommended to the City of Chicago in 1908, the following values to be used as safe working pressures for brick masonry in building construction:

| Common Brick of Crushing Strength<br>Equal to 1800 lb./in. <sup>2</sup>          | Lb. per<br>Sq. In. | Tons per<br>Sq. Ft. |
|--|--------------------|---------------------|
| In lime mortar . . . . .   | 100                | 7.2                 |
| In lime and cement mortar . . . . .  | 125                | 9.0                 |
| In natural-cement mortar . . . . .   | 150                | 10.8                |
| In Portland-cement mortar . . . . .  | 175                | 12.6                |
| Select, Hard, Common Brick, of Crushing Strength Equal<br>to 2500 Lb per Sq. In. |                    |                     |
| In 1 part Portland cement, 1 lime paste and 3 sand                               | 175                | 12.6                |
| In 1 : 3 Portland cement mortar . . . . .  | 200                | 14.4                |
| Pressed and Sewer-brick, of Crushing Strength Equal to<br>5000 Lb. per Sq. In.   |                    |                     |
| In 1 : 3 Portland cement mortar . . . . .  | 250                | 18.0                |
| Paving brick, in 1 : 3 Portland cement mortar . . . . .                          | 350                | 25.2                |

The building code of the City of St. Louis, in 1917, gives the following allowable compression on brick masonry:

|  | Per sq. in. |
|--|-------------|
| Vitrified paving brick, one part Portland cement, three parts sand . .                   | 300         |
| Strictly hard pressed brick, one part Portland cement, three parts<br>sand . . . . .     | 250         |
| Ordinary hard and red brick, one part Portland cement, three parts<br>sand . . . . .     | 200         |
| Ordinary hard and red brick, one part Portland cement, one lime,<br>three sand . . . . . | 175         |
| Merchantable brick, good lime mortar . . . . .   | 100         |

Vitrified paving brick and strictly hard brick shall not crush at less than five thousand (5000) pounds pressure per square inch. Ordinary hard and red brick shall not crush at less than two thousand and three hundred (2300) pounds pressure per square inch. Merchantable brick shall not crush at less than one thousand and eight hundred (1800) pounds pressure per square inch.

**63. Efflorescence.**—The appearance of brick masonry is sometimes marred by a white coating which exudes from the masonry and is deposited upon its surface. This is called efflorescence, and is caused by soluble salts in the brick or the mortar, usually the latter, which



are dissolved by water when the wall is wet and deposited on the surface as the water evaporates. Such deposits usually consist of salts of soda, potash, or magnesia contained in the lime or cement, or of sulphate of lime or magnesia from the brick.

Efflorescence may be prevented by keeping the wall dry. The use of impervious materials, and making the masonry itself impermeable, render the appearance of efflorescence improbable. When a wall is in a damp situation, a damp-proof course at the base of the wall to prevent moisture rising in the masonry is desirable. If the masonry is permeable and is dampened by rain, some waterproof coating may be applied to the surface of the wall. There are various patented preparations for this purpose, and the Sylvester process is sometimes successfully used. This consists in applying first a wash of aluminum sulphate (1 pound to 1 gallon of water), and then a soap solution (2.2 pounds of hard soap per gallon of water). These applications are made twenty-four hours apart. The soap solution is applied at boiling temperature. The walls must be dry and clean, and the air temperature should not be below about 50° F. when the application is made.

Efflorescence may usually be removed by scrubbing with a weak solution of hydrochloric acid.

**64. Measurement and Cost.**—Measurement of brickwork is usually made by estimating the number of thousand bricks. It is assumed that an 8- or 9-inch wall contains 15 bricks per square foot of surface; a 13-inch wall, 22½ bricks; a 17- or 18-inch wall, 30 bricks, etc. These numbers are employed without regard to the actual size of the bricks, adjustments in price per thousand being made for various sizes.

The methods of estimating are sometimes rather complicated and are subject to rules established by custom. The plain wall is the standard of measurement, openings less than 80 square feet are usually not deducted; larger openings are measured 2 feet less in width than they actually are. Hollow walls and chimneys are measured solid.

A pier is sometimes measured as a wall whose length is the circumference and whose thickness is the width of the pier. Sometimes one-half the circumference is taken as the length.

Stone trimmings are not deducted from the brickwork measurements. Various rather complicated rules are used in estimating footings, pilasters, detached chimneys, etc.

Having estimated the work in thousands of brick by these rules, a price per thousand, suited to the plain wall, is used for the entire

job. When pressed brick facing is used, the area of such facing is separately estimated. If an ashlar facing be used, its thickness is not included in that of the brick wall.

In engineering work, brickwork is usually measured, like stone masonry, by the cubic yard of actual masonry.

*Number of Bricks Required.*—The actual number of bricks needed for the construction of masonry varies with the size of the bricks and the thickness of joints. For ordinary brickwork, with common bricks of the usual ( $8\frac{1}{4} \times 4 \times 2\frac{1}{4}$  inches) size, and joints  $\frac{1}{4}$  to  $\frac{3}{8}$  inch thick, 1000 bricks will lay about 2 cubic yards of masonry. If the joints be  $\frac{1}{2}$  to  $\frac{5}{8}$  inch thick, 1000 bricks will lay about  $2\frac{1}{2}$  cubic yards.

With common bricks of ordinary size in masonry walls, six bricks will usually be required per square foot of wall surface for each width of brick in the thickness of the wall. For ordinary pressed-brick fronts, 6 to  $6\frac{1}{2}$  bricks are required per square foot of actual wall surface. In average building construction, deductions for openings will reduce the number by about one-third of those required for solid wall.

*Mortar Required.*—For ordinary building construction with  $\frac{1}{4}$  to  $\frac{3}{8}$ -inch joints, 0.5 to 0.6 cubic yard of mortar is required per 1000 bricks. This needs for 1 to 3 portland cement mortar, about 1.5 barrels of cement and 0.6 cubic yard of sand; for lime mortar about 200 pounds ( $2\frac{1}{2}$  bushels) of lime and 0.6 cubic yard of sand.

In heavy masonry with joints  $\frac{1}{2}$  to  $\frac{5}{8}$  inch, about 0.35 to 0.40 cubic yard of mortar per cubic yard of masonry, or approximately one barrel of cement and 0.4 cubic yard of sand for 1 to 3 Portland cement mortar.

*Labor of Laying Bricks.*—A bricklayer on ordinary work may lay from about 125 to 175 common bricks per hour, according to the skill of the workman and the organization of the work. He should place somewhat less than half as many face bricks. The number of bricks laid may be somewhat less with cement mortar than with lime mortar. On thin walls, with careful work, one helper may be needed for two bricklayers. On common brickwork, in building construction, one helper may be needed for each mason.

In recent work with masons at 60 to 70 cents per hour, helpers at 30 to 35 cents per hour, lime at 40 to 50 cents per bushel, the cost of laying common bricks in the walls of buildings has run from \$5 to \$8 per 1000 bricks. Costs for scaffolding, for machinery and labor in erection of brickwork necessarily vary materially with the conditions under which the work must be done.

At prices which have existed since the World War, these figures would be largely increased. Costs have varied widely in different localities and are now very unstable.

#### ART. 17. TERRA COTTA CONSTRUCTION

**65. Structural Tiling.**—Hollow tiling for use in building construction is made in many different forms. It is employed either as the main structural material or as fireproof covering for other materials.

The materials of which the tiles are made are similar to those used in making bricks, but requiring usually higher grade and more refractory materials. Shales or semi-fire clays, similar to those used for paving bricks, are frequently employed for this purpose, or sometimes fire clays are mixed with plastic clays to prevent fluxing at moderate temperatures. Tiling for use in construction may be made either dense or porous according to the qualities desired.

*Dense Tiling* is made from materials which vitrify at high temperatures (above 2000° F.) and is burned to the point of vitrification like paving bricks. This material when of good quality possesses high strength and is practically non-absorbent. It is used in outer walls of buildings, or for floor and wall construction when strength is needed.

Hollow blocks as made for ordinary wall construction are not usually vitrified, but are burned to a less degree than the best dense tiling. They must be hard burned to be of value. In the rapid growth of the tile industry, attempts have been made to produce hollow tiling from inferior materials, and soft tiles lacking in strength and durability have sometimes been offered. Care must be exercised in selecting tiling to make sure of its quality.

*Porous Tiling*, or *Terra Cotta Lumber*, is made from refractory plastic clays by mixing sawdust with the clay in forming the blocks, and burning at high temperature. The sawdust burning out leaves the material light in weight and porous. These blocks may be cut with a saw, and nails or screws may be driven into them without difficulty. This tiling does not possess the strength of good dense tiling, but is tough and less brittle, and is largely used in fireproofing and for interior walls and partitions.

Tiling of less porosity but possessing somewhat the character of the terra cotta lumber is sometimes made by mixing ground coal with the clay before burning. It is claimed that this makes a better



fireproofing than the dense tiling. These blocks are sometimes known as *semi-porous tiling*.

The *forms and sizes* of hollow blocks depend upon the uses to be made of them. For walls or partitions, the blocks are usually in 12-inch lengths, and of rectangular or interlocking sections.

Rectangular blocks are made in various sizes—12-inch widths may be had from 2 inches to 8 inches thick. Widths of 6 and 8 inches are made in thicknesses from 2 to 5 inches. They are divided by webs into cells, as shown in Fig. 38. In the heavier tiling, intended

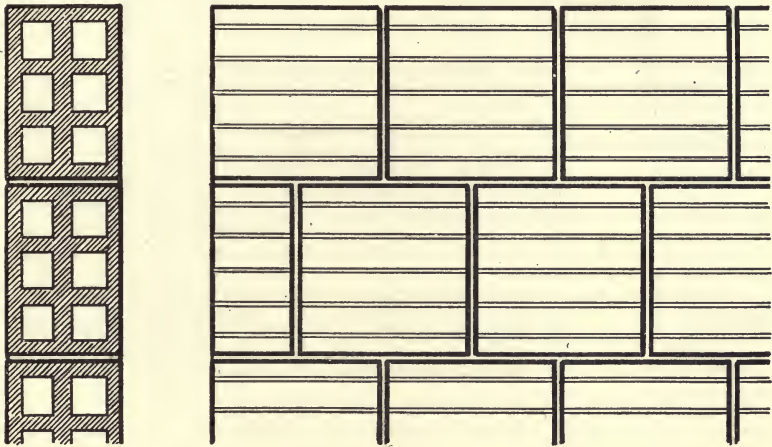

FIG. 38.—Hollow Rectangular Blocks.

for use where loads are to be carried, and in outside walls, the shells are at least 1 inch and the webs at least  $\frac{3}{4}$ -inch in thickness, and the cells not more than  $3\frac{1}{2}$  or 4 inches in width. In lighter tiling, used as filler in concrete work or for light partitions, the webs are  $\frac{3}{8}$  to  $\frac{1}{2}$  inch, and cell openings may be 5 or 6 inches.

*Interlocking blocks* are made in various shapes, with the object of improving the bond of the wall, and eliminating joints extending through the wall. These blocks are often used in outside walls to prevent moisture passing through the wall and provide air spaces in all parts of the wall. Fig. 39 shows one of the common forms of interlocking tile.

Hollow blocks for use in fire protection are made in many shapes to fit around structural members of other materials. They are also made to fit together in round or flat arches to support floors between steel beams.

Good tiling must be well burned, true in form and free from checks or cracks, and should give a ringing sound when struck with metal.

The following requirements for hollow tile are given in the Building Code of the city of St. Louis for 1917:

All hollow tile used in the construction of walls or partitions shall be hollow shale or terra cotta, well manufactured and free from checks and cracks, each piece or block to be molded square and true and to be hard burned so as to give a good clear ring when struck, and not to absorb more than twelve (12) per cent of its own weight in moisture. Each of said blocks shall develop an ultimate crushing strength of not less than three thousand (3000) pounds per square inch of available section of web area, and shall not be loaded when in the wall more than eighty (80) pounds per square inch of effective bearing area. Tiles shall

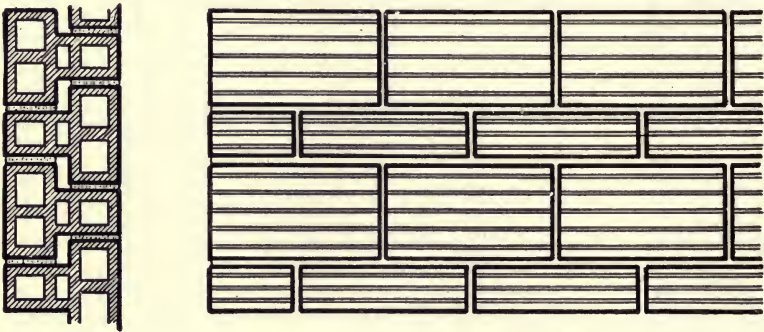

FIG. 39.—Interlocking Tile.

have outer shells or walls not less than three-quarters ( $\frac{3}{4}$ ) of an inch thick and shall be additionally reinforced by continuous interior walls or webs which shall not be less than one-half ( $\frac{1}{2}$ ) inch thick, and so arranged that no void shall exceed four (4) inches in cross-section at any point. It is further provided that the building commissioner may require a test to be made of such blocks before allowing the same to be placed in the wall, if, in his judgment, there be any doubt as to whether such blocks, proposed to be used, meet the requirements above specified.

**66. Block Construction.**—In the construction of walls of ordinary hollow rectangular blocks, the blocks are usually laid so as to break joints and extend through the walls. They should be so placed that the vertical webs in each course are directly above those in the course below. Such construction is shown in Fig. 38.

In using tile with horizontal cells, jamb blocks and corner blocks are made with the cells vertical. When very light walls are used, longitudinal reinforcement, consisting of thin band iron or of special forms of wire mesh, is placed in the joints. This is necessary for 2-inch partitions or for 3-inch partitions more than 10 feet high.

Tiles with vertical cell openings are made by some makers. Fig. 40 shows construction with standard tiling of this type.

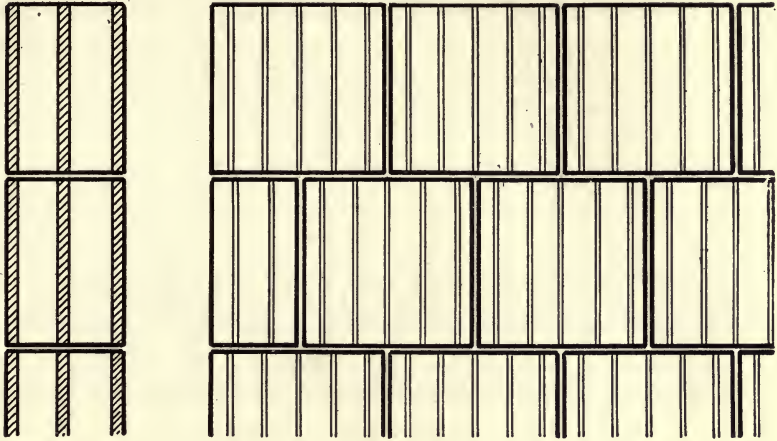

FIG. 40.—Walls of Natco Hollow Blocks.

Portland cement mortar, or mortar of lime and cement, is used in laying hollow blocks. In walls which are to carry considerable loads, Portland cement with 10 to 15 per cent of hydrated lime by volume (4 to 6 per cent by weight) should be used in 1 to 3 mortar with well-graded sand. For walls which are not to carry loads, a larger amount (equal volumes) of lime may be used. The surfaces of tiles are often grooved to aid the adhesion of the mortar in the joints. When the finish of the wall is to be plaster or stucco, the surface of the tile is grooved to hold the plaster. If brick veneer is to be applied, or if the surface of the tile is to be used for exterior finish, a smooth finish may be desirable.

*Floor Construction.*—The method of using hollow blocks in flat arch floor construction is shown in Fig. 41. These arches vary from

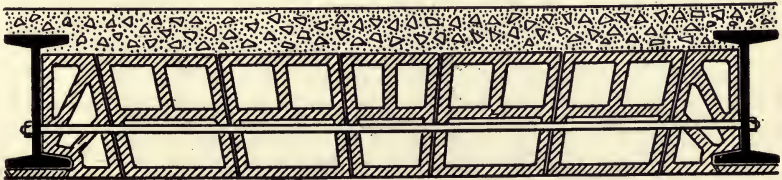

FIG. 41.—Flat Arch Floor Construction.

about 3 to 6 feet in span and from 6 to 12 inches in depth. The blocks required consist of the skewback, the fillers and the key-block.



The skewbacks are usually made of such form as to enclose the bottom of the I-beam for fire protection.

Such arches are now commonly made by the end-construction method in which the cell openings run lengthwise of the arch. The blocks do not break joints, but form a series of independent arches side by side. A number of different shapes are offered for these arches by different makers, lighter weight being obtained than with side-construction arches for the same strength.

Hollow blocks are frequently used as fillers in reinforced concrete floors, the blocks filling spaces between the webs of the T-beams of concrete, as shown in Fig. 42. Blocks 12 inches wide are usually

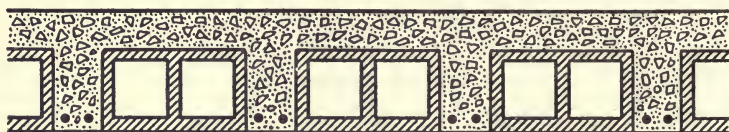

FIG. 42.—Hollow Block Fillers in Concrete Floors.

employed for this purpose, the depth depending upon the span and loading of the floor.

*Strength of Block Masonry.*—Comparatively few data are available upon the strength of constructions of terra-cotta blocks. A very carefully constructed wall of natco tile (see Fig. 40) was tested by R. W. Hunt & Company. The wall was  $36\frac{5}{8}$  inches long, 8 inches thick, and 12 feet  $2\frac{1}{2}$  inches high, and was twenty-eight days old when tested. It failed under a load of 436,000 pounds, giving a compression of 3110 lb./in.<sup>2</sup> on the net section of the web, or about 1500 lb./in.<sup>2</sup> of gross area. Tests of a wall of Denison tile (see Fig. 39) faced with brick, forty-two days old, was made at the laboratory of the Bureau of Standards. This wall was 5 feet, 1 inch in length,  $12\frac{1}{2}$  inches thick, and 31 feet high. It carried a load of 686,000 pounds, or about 900 lb./in.<sup>2</sup> of gross area.

Good dense tiling should have a crushing strength of 3000 to 6000 lb./in.<sup>2</sup> of net section. When laid in masonry the allowable load is usually not more than one-fifteenth of the ultimate strength of the block. Carefully laid masonry of good quality hollow blocks may be allowed to carry a load of 200 lb./in.<sup>2</sup> of net section of block, or in general about 5 tons per square foot of gross area.

**67. Architectural Terra-cotta.**—Terra-cotta for exterior finish or ornamental work is usually made from a mixture of clays, carefully selected to secure the desired qualities. The clay is ground, mixed, tempered, and worked to a proper condition of plasticity. It is

then formed into the desired shapes in plaster molds or by hand, modeled as may be necessary, and dried. After drying, it is given a surface treatment, by spraying with a liquid upon the surface, which determines the kind of finish to be given in burning and its color.

The blocks of terra-cotta may have a length up to 30 inches, and depth of 6 to 10 inches, with height according to the requirements of the work. They are constructed as hollow shells with webs about  $1\frac{1}{4}$  inches thick, and cells 6 inches or less in width. These blocks are built into the body of the wall by bonding the masonry into and filling the cells.

Several kinds of surface finish are used for terra-cotta. Standard terra-cotta is that in which no special finish is applied, leaving the block somewhat porous. Vitreous terra-cotta has a spray applied to the surface which causes the surface material to vitrify during burning, making the material non-absorbent. Glazed terra-cotta has an impervious coating of glaze upon the surface. When the glaze is deadened, it is called mat-glazed. A variety of colors are available for use with this material, and make its use possible in a wide range of artistic designs.

Terra-cotta of good quality is one of the most durable materials for use in the trimming and ornamentation of masonry structures. Being practically non-absorbent, it is not affected by frost, or by the gases in the atmosphere. The facility with which it may be worked into desired forms makes it a desirable material for artistic design.

#### ART. 18. GYPSUM AND CEMENT BLOCK CONCRETE

**68. Gypsum Wall Blocks.**—Blocks made by mixing gypsum plaster (see Section 37) with wood fiber or similar materials are used for partition walls in fireproof building construction. They are made 30 inches long, 12 inches high, and from 3 to 8 inches thick, with tapering openings through the block.

They are laid in the wall to break joints and cemented with mortar composed of gypsum cement plaster and sand, usually 1 to 3. They are not used for walls bearing loads, but form very light partitions, and have good soundproof and fireproof qualities.

The 3-inch blocks are used to a height of wall of about 12 feet, the 4-inch to 17 feet, and the 6-inch to 24 feet. The material may be cut with a saw, and plaster is applied directly to their surfaces.

The weights of walls of hollow gypsum blocks are approximately as follows:

|  |    |    |    |    |    |
|--|----|----|----|----|----|
| Thickness of block, inches . . . . .   | 3  | 4  | 5  | 6  | 8  |
| Weight of wall, lb per sq. ft. . . . . | 10 | 13 | 16 | 20 | 26 |

Three pounds per square foot is added for plaster upon each side of the wall.

**69. Roofing and Floor Blocks.**—Blocks of gypsum, similar in composition to the partition blocks, and reinforced with wire mesh, are made both in solid and hollow form for use in roof construction. They are usually 3 or 4 feet in length and are used to span the openings between purlins and form a solid deck upon which the roof covering may be placed. They are made with beveled edges, and are set with their lower edges in contact and the triangular openings between them filled with a grout of cement plaster. Blocks with heavier reinforcement for openings up to 10 feet in span are also now offered.

*Floor blocks*, to be used as fillers in reinforced-concrete floor construction, are now available. These are designed to act as forms for the concrete, and require support at the ends of the blocks, which are 2 feet long. A spacer is placed between two adjoining blocks to hold the concrete for the web of the beam, forming a smooth surface on the under side upon which plaster may be placed. A section of floor constructed with these blocks is shown in Fig. 43.



FIG. 43.—Pyrobar Gypsum Floor Tile.

**70. Concrete Blocks.**—Hollow building blocks of Portland cement concrete are frequently employed in building construction in the same manner as in solid concrete construction, given in Chapter V, and the concrete is proportioned and mixed in the same manner.

The blocks are usually made to set in the wall with the webs in a vertical position. Several patented forms are on the market which make blocks to bond in the wall in different ways and giving air spaces more or less effective as insulation against moisture and heat. Such blocks, when well made and properly set, make a sub-



stantial and durable building, and may be used in such manner as to give a pleasing appearance. The color of the blocks may be regulated by choice of the aggregate used upon their exposed faces. The use of coloring matter in the concrete has not usually been very successful, although there are mineral colors available which may be used without material injury to the concrete.

Metal molds are commonly employed, and concrete of rather dry consistency is compressed into them by tamping or by hydraulic pressure. This yields concrete of greatest strength and also makes a block which may be quickly removed from the mold. For ornamental work, sand molds are frequently employed, a wooden pattern being used in forming the mold, and the concrete poured in a wet mixture.

The curing of the blocks is important in its effect upon the strength and durability of the concrete, which must not dry out during the period of hardening. After the blocks are removed from the molds, they are allowed to stand in the air until the cement has set, when they may be transferred to a steam chamber, where they are subjected to an atmosphere charged with steam at a temperature about  $110^{\circ}$  to  $130^{\circ}$  F. After two or three days in the steam, they may be removed to the open air, but should be sprinkled often enough to keep them continually damp for ten or twelve days. When a steam chamber is not employed, the blocks are cured in the open air, but should be kept wet for a longer period to give time for complete hardening. The temperature to which they are subjected during hardening should never go lower than about  $50^{\circ}$  F.

## CHAPTER V

### PLAIN CONCRETE

#### ART. 19. AGGREGATES FOR CONCRETE

**71. Materials Used for Aggregates.**—Concrete as used in construction is essentially a mixture of cement mortar with broken stone, gravel, or other coarse material. The mortar serves to fill the voids in the stone and the whole is bound into a solid monolith by the setting and hardening of the cement.

The materials mixed with the cement in forming concretes are known as aggregates. The sand or stone chips in the mortar is called the *fine aggregate* and the coarser gravel or broken stone is the *coarse aggregate*. In the manufacture of good concrete it is essential that each of the materials be of proper quality, and that they be properly proportioned and incorporated into the mixture.

*Fine Aggregate.*—Material which will pass a  $\frac{1}{4}$ -inch screen is usually included under the term fine aggregate, or sand. The requirements for sand and its use in mortar have been discussed in Chapter II. Ordinarily, the sand which makes the strongest and most dense mortar will also give the best results in concrete, though this may not always be the case. The grading of the sand should be such as to reach maximum density when combined in proper proportions with the coarse aggregate to be used in the concrete.

*Coarse Aggregate.*—This may consist of any hard mineral substance broken to proper size—usually broken stone or gravel, although sometimes broken slag, cinders, or broken brick is used.

The value of stone as an aggregate depends upon much the same qualities as are needed for building stone. For high-class concrete work, it is important that the stone should possess strength, and absorb but little water. Stones breaking to cubical shapes give better results than those of shaly or slaty character, while rounded pieces pack closer and show less voids than those with sharp corners.

Trap and granite are usually the best of concrete materials. When the concrete is to be subjected to abrasive wear, trap is a superior material. For resistance to direct compression, good granite

is to be preferred. Limestones and sandstones vary greatly in their values as concrete materials, hard limestones and some of the more compact sandstones being desirable materials, while the softer varieties are not generally suitable for first-class concrete work. Gravel, when of flint or other hard material, may make excellent concrete.

*Sizes for Broken Stone.*—The sizes to which concrete stone should be broken depends upon the use to which the concrete is to be put. In heavy walls or massive work, the upper limit of size may be 2 or 3 inches in diameter. It is desirable to have the stones as large as can be easily incorporated into the mixture. In reinforced work, where the concrete must pass between and under the reinforcing rods, it may not be feasible to use stone of more than 1 inch diameter.

In stone or gravel for coarse aggregate, as in sand for mortar, the grading of sizes should be such as to give maximum density. For a given stone, the strongest concrete will ordinarily be made by that arrangement of sizes which requires the least mortar to completely fill the voids in the stone, as a surplus of mortar beyond that required for completely filling the voids is an element of weakness in the concrete, as well as a waste of the more expensive materials. Stone as ordinarily used in concrete contains all sizes, from the largest allowed to the size of the largest sand. All material retained on a  $\frac{1}{4}$ - or  $\frac{3}{8}$ -inch screen is commonly regarded as coarse aggregate, and stone is used as it comes from the crusher with all the sizes included, only the chips being screened out.

Gravel containing sand is sometimes used without screening by mixing with cement. This is not desirable practice, as the sand is seldom in proper quantity or uniformly distributed through the gravel, it should be screened out and proportioned properly to the cement and gravel.

In concrete work it is usually necessary to use the materials available in the locality of the work, but where important work is to be done, careful attention should be given to the character of these materials and of the concrete made from them. The design of concrete structures should be based upon full information concerning the properties of the concrete to be used, and this is largely a question of aggregates. Poor concrete work has much more frequently resulted from the use of poor aggregates than from the use of inferior cement.

In many cases it may be feasible and desirable to use materials of low grade in concrete work. Cinder concrete is preferred for some uses on account of its lightness, although it is low in strength. Local materials may be of poor quality, but usable by taking proper pre-



cautions and designing the work in accordance with the character of the concrete. Failures have sometimes resulted from the use of low-grade materials without investigation of their qualities. Many users of concrete have failed to recognize the importance of the quality of the aggregates and seem to have regarded any stone broken to proper size as good enough for concrete.

**72. Tests for Coarse Aggregates.**—There are at present no standard methods of making tests for concrete aggregates, or standard specifications for such materials. The methods usually employed in testing sand have been discussed in Art. 7. A committee of the American Society for Testing Materials is making a study of concrete aggregates and of the methods of testing them, and it is hoped that this may result in a standard practice in making such tests, and in throwing light upon methods of proportioning and forming the concrete.

*Mechanical Analysis.*—To determine the relative quantities of various sizes of stone in aggregate, it is common to make a mechanical analysis of the material. This consists in separating the various sizes by screening, and recording the amount retained upon each screen. The following has been adopted by the American Society for Testing Materials, upon recommendation of its Committee on Road Materials, as a standard method for making a mechanical analysis of broken stone or broken slag, *except for aggregates used in cement concrete:*

The method shall consist of (1) drying at not over 110° C. (230° F.) to a constant weight a sample weighing in pounds six times the diameter in inches of the largest holes required; (2) passing the sample through such of the following size screens having circular openings as are required or called for by the specifications, screens to be used in the order named: 8.89 cm. (3½ in.), 7.62 cm. (3 in.), 6.35 cm. (2½ in.), 5.08 cm. (2 in.), 3.81 cm. (1½ in.), 3.18 cm. (1¼ in.), 2.54 cm. (1 in.), 1.90 cm. (¾ in.), 1.27 cm. (½ in.), and 0.64 cm. (¼ in.); (3) determining the percentage by weight retained by each screen; and (4) recording the mechanical analysis in the following manner:

|  |       |
|--|-------|
| Passing 0.64 cm. (¼ in.) screen.....   | ..... |
| Passing 1.27 cm. (½ in.) screen and retained on a 0.64 cm. (¼ in.) screen..... | ..... |
| Passing 1.90 cm. (¾ in.) screen and retained on a 1.27 cm. (½ in.) screen..... | ..... |
| Passing 2.54 cm. (1 in.) screen and retained on a 1.90 cm. (¾ in.) screen..... | ..... |

For materials in which sand is combined with the broken stone or broken slag, the same method is employed together with the fine sieves used for sand (see Art. 7) and the results are recorded in the same manner, beginning with the 200-mesh sieve.

*Apparent Specific Gravity.*—The weight of a given volume of the solid material of which the aggregate is composed is often of importance in the determination of voids, or in proportioning concrete, a result obtained by determining the apparent specific gravity. The term apparent specific gravity as here used refers to the material as it exists, and includes the voids in the block of material tested; it may be somewhat less than the true specific gravity. For this purpose, the water to which it is referred need not be distilled, and determinations at ordinary air temperatures are sufficiently accurate.

The following method of determining apparent specific gravity of coarse aggregates has been adopted as standard by the American Society for Testing Materials.

The apparent specific gravity shall be determined in the following manner:

1. The sample, weighing 1000 g. and composed of pieces approximately cubical or spherical in shape and retained on a screen having 1.27 cm. ( $\frac{1}{2}$  in.) circular openings, shall be dried to constant weight at a temperature between 100 and 110° C. (212 and 230° F.), cooled, and weighed to the nearest 0.5 g. Record this weight as weight *A*. In the case of homogeneous material, the smallest particles in the sample may be retained on a screen having  $1\frac{1}{4}$  in. circular openings.

2. Immerse the sample in water for twenty-four hours, surface-dry individual pieces with the aid of a towel or blotting paper, and weigh. Record this weight as weight *B*.

3. Place the sample in a wire basket of approximately  $\frac{1}{4}$  in. mesh, and about 12.7 cm. (5 in.) square and 10.3 cm. (4 in.) deep, suspend in water<sup>1</sup> from center of scale pan, and weigh. Record the difference between this weight and the weight of the empty basket suspended in water as weight *C*. (Weight of saturated sample immersed in water.)

4. The apparent specific gravity shall be calculated by dividing the weight of the dry sample (*A*) by the difference between the weights of the saturated sample in air (*B*) and in water (*C*), as follows:

$$\text{Apparent Specific Gravity} = \frac{A}{B - C}$$

5. Attention is called to the distinction between apparent specific gravity and true specific gravity. Apparent specific gravity includes the voids in the specimen and is therefore always less than or equal to, but never greater than the true specific gravity of the material.

<sup>1</sup> The basket may be conveniently suspended by means of a fine wire hung from a hook shaped in the form of a question mark with the top end resting on the center of the scale pan.

The specific gravities and weights per cubic foot of materials commonly used for aggregates are approximately as follows:

|                        | Specific Gravity. | Weight per Cubic Foot. |
|------------------------|-------------------|------------------------|
| Gravel.....            | 2.65              | 165                    |
| Trap.....              | 2.85-3.00         | 178-187                |
| Granite.....           | 2.65-2.80         | 165-175                |
| Limestone.....         | 2.50-2.75         | 155-170                |
| Compact sandstone..... | 2.45-2.70         | 153-168                |
| Porous sandstone.....  | 2.10-2.40         | 130-150                |
| Cinders.....           | 1.40-1.60         | 90-100                 |

*Determination of Voids.*—The voids in coarse material, such as gravel or broken stone not containing sand or other fine material, may be obtained by filling a measure of known volume with the material, and pouring in water until the measure is full.

$$\text{Then, the percentage of voids} = \frac{\text{The volume of water}}{\text{The total volume}} \times 100.$$

When the specific gravity of the material is known, the voids may be obtained by weighing a measured volume of the broken stone, subtracting this weight from the weight of an equal volume of the solid material, and dividing by the solid weight.

If the aggregate contains fine material, the methods used for sand as given in Art. 7 must be used.

It is evident that the percentage of voids in a mass of broken material is not a fixed quantity, but varies with the arrangement of the pieces. If the material were composed of equal cubes, it would be possible to place them side by side so as to leave no voids which could be filled by smaller material. Poured loosely into a measure, such cubes would probably show at least 45 per cent of voids, which would be somewhat modified by shaking down and compacting the mass.

When the aggregate contains small pieces which may lie in the voids of the larger ones, the tendency to variation in results according to arrangement is greatly reduced, but the method of filling the measure, and amount of shaking that is given, will somewhat affect the results. Commonly, the material is shoveled into the measure and lightly shaken to get what may be a fair estimate of the voids in the material as it is to be used.

When fine material is introduced into a coarse aggregate to fill the voids, particles of the fine material get between the larger pieces



and hold them apart so that the voids to be filled in the larger material are increased, and cannot be completely filled. This is shown by the fact that the volume of the mixture is greater than that of the coarse aggregate even though the volume of fine aggregate used is much less than the volume of voids in the larger material.

*Selection of Aggregates.*—The Joint Committee of the Engineering Societies on Concrete and Reinforced Concrete makes the following recommendations concerning the selection of aggregates in its 1917 report.

#### AGGREGATES

Extreme care should be used in selecting the aggregates for mortar and concrete, and careful tests made of the materials for the purpose of determining the quality and grading necessary to secure maximum density or a minimum percentage of voids. Bank gravel should be separated by screening into fine and coarse aggregates and then used in the proportions to be determined by density tests.

(a) *Fine aggregate* should consist of sand, or the screenings of gravel or crushed stone, graded from fine to coarse, and passing when dry a screen having  $\frac{1}{4}$  in. diameter holes; it preferably should be of siliceous material, and not more than 30 per cent by weight, should pass a sieve having 50 meshes per linear inch; it should be clean, and free from soft particles, lumps of clay, vegetable loam, or other organic matter.

Fine aggregate should always be tested for strength. It should be of such quality that mortar composed of 1 part Portland cement and 3 parts fine aggregate by weight when made into briquettes, prisms or cylinders will show a tensile or compressive strength, at an age of not less than seven days, at least equal to the strength of 1:3 mortar of the same consistency made with the same cement and standard Ottawa sand. If the aggregate be of poorer quality, the proportion of cement should be increased to secure the desired strength. If the strength developed by the aggregate in the 1:3 mortar is less than 70 per cent of the strength of the Ottawa sand mortar, the material should be rejected. In testing aggregates care should be exercised to avoid the removal of any coating on the grains which may affect the strength; bank sands should not be dried before being made into mortar, but should contain natural moisture. The percentage of moisture may be determined upon a separate sample for correcting weight. From 10 to 40 per cent may be required in mixing bank or artificial sands than for standard Ottawa sand to produce the same consistency.

*Coarse aggregate* should consist of gravel or crushed stone which is retained on a screen having  $\frac{1}{4}$  in. diameter holes, and should be graded from the smallest to the largest particles; it should be clean, hard, durable, and free from all deleterious matter. Aggregates containing dust and soft, flat, or elongated particles should be excluded. The Committee does not feel warranted in recommending the use of blast-furnace slag as an aggregate, in the absence of adequate data as to its value, especially in reinforced concrete construction. No satisfactory specifications or methods of inspection have been developed that will control its uniformity and ensure the durability of the concrete in which it is used.

The aggregate must be small enough to produce with the mortar a homo-

geneous concrete of sluggish consistency which will readily pass between and easily surround the reinforcement and fill all parts of the forms. The maximum size of particles is variously determined for different types of construction from that which will pass a  $\frac{1}{2}$ -in. ring to that which will pass a  $1\frac{1}{2}$ -in. ring.

For concrete in large masses the size of the coarse aggregate may be increased, as a larger aggregate produces a stronger concrete than a fine one; however, it should be noted that the danger of separation from the mortar becomes greater as the size of the coarse aggregate increases.

Cinder concrete should not be used for reinforced concrete structures except in floor slabs not exceeding 8-foot span. It also may be used for fire protection purposes when not required to carry loads. The cinders should be composed of hard, clean, vitreous clinker, free from sulphides, unburned coal or ashes.

## ART. 20. PROPORTIONING CONCRETE

**73. Arbitrary Proportions.**—The common method of proportioning concrete is by assuming ratios between the volumes of cement, sand, and coarse aggregate. These proportions are varied according to the character of the work, and sometimes are adjusted to the qualities of the materials. A formula of definite proportions does not always lead to the same result unless the method of measuring the materials is the same, as cement measured loose may vary considerably in weight for the same volume. A barrel of cement may measure from 3.5 to 5 feet, according to its degree of compactness. It is desirable to follow the recommendation of the Joint Committee on Concrete and take one sack (94 pounds) of cement as a cubic foot, or a barrel as 4 cubic feet in measuring the materials.

Specific fixed proportions have to a certain extent become standard in ordinary practice for various kinds of work. For reinforced concrete in building construction and where it is necessary to develop considerable strength, the proportions of 1 part cement, 2 parts sand, and 4 parts broken stone are commonly employed. For positions where strength is of special importance, as in column construction, or work in light superstructures of buildings, the proportions  $1 : 1\frac{1}{2} : 3$ , or sometimes  $1 : 1 : 2$ , are used. In more massive work and where only compressions are to be carried with ample sections, the proportions  $1 : 3 : 6$  and sometimes  $1 : 2\frac{1}{2} : 5$  are employed.

The common proportions are based upon the requirement that the volume of fine aggregates shall be one-half that of the coarse aggregate. For materials commonly used, this gives a quantity of mortar sufficient to fill compactly the interstices in the coarse aggregate. The quality of the mortar is varied by changing the ratio of cement to fine aggregate, and the strength of the concrete

varies accordingly. The ratios between fine and coarse aggregates are often varied when the coarse aggregates contain more or less voids than is usual, and 1 : 2 : 3, 1 : 3 : 5, 1 : 2 : 5 or 1 : 3 : 7 concrete is frequently used.

Good results have been obtained in practice by this method of proportioning, when proper attention has been given to the quality of the aggregates. More careful methods of adjusting proportions would often be more economical, and equally good results might sometimes be obtained with less cost for materials. Many users of concrete employ ordinary proportions for all concrete irrespective of the character of the materials, and a wide variation in the quality of the concrete is frequently the result.

**74. Proportioning by Voids.**—A method of proportioning sometimes followed is to determine the voids in the aggregates, and use enough cement to fill the voids in the fine aggregate and enough mortar to fill the voids in the coarse aggregate. A small excess of fine materials is used in each case on account of inequalities of mixing. If the fine materials would all lie in the voids of the larger materials, this method would always give the desired result, and produce the concrete of maximum density and greatest strength. In practice, however, the voids cannot be completely filled, the volumes of the larger materials are increased by the smaller particles lying between them, and the distribution of fine material through the mass is not uniform.

Usually a volume of mortar 5 to 10 per cent in excess of the voids most nearly fills the voids without leaving appreciable excess of mortar. More mortar than this swells the volume of the concrete without increasing density, and has the effect of weakening the concrete. If, for instance, sand containing 50 per cent voids is used with stone containing 40 per cent voids, and just fills the voids in the stone without increasing the volume, the resulting mixture will have 20 per cent voids. If an excess of sand be used, this excess will give an increase in volume having 50 per cent voids.

This method of proportioning is an improvement over that of arbitrary selection of ratios, and usually gives approximately the most desirable proportions. Variations in the relative sizes of the materials, however, may change considerably the proportions necessary to give the most dense concrete. A certain sand may easily work into the voids of a given broken stone without materially increasing its volume, while with another stone containing the same percentage of voids but of different sizes, the same sand may produce quite different results, and to secure greatest density would need



to be differently proportioned. The object should be to get the greatest density in the final mixture of fine and coarse aggregates.

The inaccuracies involved in proportioning cement to sand by determining the voids in the sand is explained in Art. 7. When determining the ratio of fine to coarse aggregates by the method of voids, it is usual to proportion cement to sand by adopting an arbitrary ratio between the two, although some users of concrete have used the void method for this purpose also.

**75. Proportioning by Mechanical Analysis Curves.**—Mr. William B. Fuller<sup>1</sup> has devised a method of proportioning concrete by plotting the curves of mechanical analysis of the aggregates to be used, then combining them in such proportions as to give a curve which corresponds as nearly as possible with a certain ideal curve. This ideal curve is supposed to represent the combination of sizes which will give maximum density for the given materials.

*Mechanical Analysis Curve.*—The method of plotting the curves of mechanical analysis is shown in Fig. 44. The analyses are made

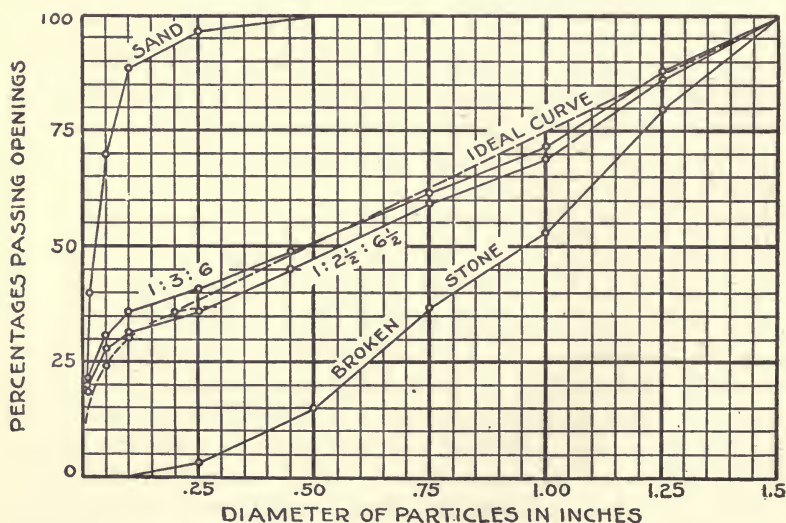

FIG. 44.—Curves of Mechanical Analyses.

by the method outlined in Section 72. In the curves, the ordinates represent percentages of the samples (by weight) which pass through

<sup>1</sup> An explanation of this method of proportioning is given by Mr. Fuller in Taylor and Thompson's "Concrete, Plain and Reinforced," Third edition, Chapter X.

openings whose sizes are shown by their distances from the origin. Fig. 44 shows a sample of stone and one of sand which are to be used in forming concrete.

From these curves, others may be drawn showing the grading of sizes in various combinations of cement, sand, and stone. Thus for the 1 : 3 : 6 concrete, we will have percentages passing openings as follows:

| Sizes of Openings,<br>inches. | PERCENTAGES PASSING. |          |          |        |
|-------------------------------|----------------------|----------|----------|--------|
|                               | Cement.              | Sand.    | Stone.   | Total. |
| 1.50                          | 10                   | + 30     | + 60     | = 100  |
| 1.25                          | 10                   | + 30     | + .80×60 | = 88   |
| 1.00                          | 10                   | + 30     | + .53×60 | = 71.8 |
| .75                           | 10                   | + 30     | + .37×60 | = 62.2 |
| .50                           | 10                   | + 30     | + .15×60 | = 49   |
| .25                           | 10                   | + .97×30 | + .03×60 | = 41   |
| .10                           | 10                   | + .88×30 | + 00     | = 36.4 |
| .05                           | 10                   | + .70×30 | + 00     | = 31   |
| .02                           | 10                   | + .40×30 | + 00     | = 22   |

This curve, corresponding to 10 per cent cement, 30 per cent sand, and 60 per cent stone, is shown on the diagram, as is the curve for 1 : 2½ : 6½ concrete.

The ideal curve is found by sifting the stone and sand into a number of sizes, and then recombining these sizes in varying proportions and comparing the results, until the condition of maximum density is obtained. In an extended series of experiments, Messrs. William B. Fuller and Sanford E. Thompson<sup>1</sup> found that the curve of most desirable grading of materials was a smooth curve, consisting of an ellipse at the fine end with a straight line tangent to the ellipse and passing through the point where 100 per cent is reached. The materials tested in these experiments consisted of broken stone, gravel, and sand used in the construction of the Jerome Park Reservoir, at New York. The equation for the ellipse as determined from these experiments is

$$(y-7)^2 = \frac{b^2}{a^2}(2ax-x^2),$$

$x$  and  $y$  being the horizontal and vertical coordinates of points on the ellipse measured from the origin of the diagram.

<sup>1</sup> Transactions, American Society of Civil Engineers, Vol. LIX, p. 67.

The values of  $a$  and  $b$  vary for the different materials and are as follows:

| Materials.                                   | $a$                 | $b$                 |
|--|---------------------|---------------------|
| Jerome Park stone and screenings . . . . .   | 0.035-0.14 <i>D</i> | 29.4-2.2 <i>D</i>   |
| Cow Bay gravel and sand . . . . .            | 0.04 -0.16 <i>D</i> | 26.4-1.3 <i>D</i>   |
| Jerome Park stone and Cow Bay sand . . . . . | 0.04 -0.16 <i>D</i> | 28.5-1.3 <i>D</i> . |

$D$  in the above formulas is the maximum diameter of the coarse aggregate.

To use this method of proportioning it is first necessary to determine the ideal curve. Sufficient data are not available to indicate whether the formulas given above are generally representative of broken stone and gravel respectively. To determine the curve in a particular case, the sand and stone should each be sifted into about three sizes. A trial curve may then be assumed and the materials mixed in proportions to agree with the curve and the density of the mixture tested. Curves above and below the first one can be tried until an approximate density is located.

**76. Proportioning by Trial.**—The simplest and usually the most accurate way of determining the ratios of quantities of materials for concrete is that of mixing batches in different proportions and comparing the densities of the resulting concrete. The object should be to secure the mixture of aggregates which will give the greatest density when mixed with the cement and water.

For making these tests, it is convenient to use a cylindrical measure 8 or 10 inches in diameter and 12 or 15 inches high. A batch of concrete is mixed in assumed proportions to the consistency to be used in the work, and the height to which it fills the cylindrical measure is noted. Other batches are then prepared with the same total weight of materials, but differing in proportions of aggregates, and measured in the same manner. The greatest density is that which occupies the least volume for the same weight. It is necessary to use a uniform method of filling the cylinders, and is usually desirable to compact the concrete by light ramming in rather thin layers to prevent voids being left where the concrete is in contact with the surface of the cylinder.

*Amount of Cement.*—In this method of proportioning, as in the preceding methods, the object is to determine the proper proportions of aggregates to give the most dense concrete. In each case, the amount of cement to be used is assumed as a definite ratio to



the total weight of aggregates. This ratio depends upon the character of the work and the need for strength in the concrete, and is determined as mentioned in Section 82. In many instances, on important work, it is desirable to test the strength of the concrete as well as the density and modify the proportion of cement to suit the requirements. With different aggregates the strength may be quite different when the same proportion of cement is used, and economy in the use of cement may result from determination of the actual strength of concrete with varying proportions of cement to aggregate. (See Section 102.)

More cement is usually required to produce the same strength when the sizes of the coarse aggregates are small than when larger aggregates are used. Stone broken to pass a  $\frac{3}{4}$ -inch screen may require 20 to 25 per cent more cement for the same strength than the same stone broken to pass a 1.5-inch screen.

**77. Fineness Modulus and Surface Area.**—Several studies of methods of proportioning concrete have recently been made, involving extensive experimental investigations and resulting in suggestions of new methods. The tests of Mr. D. A. Abrams in the Structural Materials Laboratory at the Lewis Institute at Chicago led to the conclusion that, for a given ratio of cement to aggregate, the proportions requiring the least water to produce the required consistency would give the greatest strength. This would depend primarily upon the grading of the aggregate in size, and Mr. Abrams evolved a method by the use of what he calls the "fineness modulus," based upon the mechanical analysis of the aggregate. The Tyler series of sieves is used, Nos. 100, 48, 28, 14, 8, 4, etc., each of which has openings twice the diameter of those of the preceding ones. Mr. Abrams method is given in Bulletin No. 1 of the Structural Materials Research Laboratory.

Mr. L. N. Edwards has proposed<sup>1</sup> a method of proportioning concrete by means of the surface areas of the particles of aggregate. A theoretical study of this method of proportioning has been made by Mr. R. B. Young,<sup>2</sup> in which he claims that the quantity of water necessary to bring a concrete mixture to a given consistency is dependent upon the surface area of the aggregates.

These and other investigations in progress are throwing much light upon the subject of proportioning concrete and upon its qualities. The concrete is affected by a number of elements, each of which must be considered in determining the best proportions. The ratio

<sup>1</sup> Proceedings, American Society for Testing Materials, 1918, Part II.

<sup>2</sup> Proceedings, American Society for Testing Materials, 1919, Part II.

of cement to aggregate, the voids in the aggregates, the surface areas of the aggregates, the quantity of water used in mixing are all important, and are all directly concerned with the grading of sizes of aggregates. Some method based upon mechanical analysis may finally be standardized for general use, when the relative importance of the various factors are more fully understood. Any of the methods proposed may be employed as a guide in selecting proportions, but actual trial of the materials in concrete is necessary to give certainty in results.

**78. Yield of Concrete.**—The quantities of materials needed for a cubic yard of concrete vary with the amount of voids in the aggregates and the proportions in which they are combined. The sizes of the aggregates and the quantity of water used in mixing also influence the yield of concrete.

Concrete is made up of a mixture of cement, fine aggregate, and coarse aggregate, or it is a mixture of cement mortar with coarse aggregate. The volume of the concrete is the sum of the volumes of the mortar, the solid material in the coarse aggregate and the unfilled voids in the coarse aggregate.

- Let  $C$  = Volume of cement in cubic feet (bags of 94 pounds each);  
 $S$  = Volume of fine aggregate in cubic feet;  
 $R$  = Volume of coarse aggregate in cubic feet;  
 $V$  = Volume of voids in coarse aggregate in cubic feet;  
 $s$  = Ratio of sand to cement =  $S/C$ ;  
 $r$  = Ratio of coarse aggregate to cement =  $R/C$ ;  
 $v$  = Ratio of voids to total volume of coarse aggregate,  $V/R$ .

The quantities of ingredients necessary to produce given volumes of cement mortars, and the variations for different materials, are discussed in Section 34, and while these quantities vary considerably with different materials, the volume of mortar produced by the mixture of different proportions of cement and sand is fairly well expressed by the expression:

$$\text{Volume of mortar} = aC + bS,$$

in which  $a$  and  $b$  are coefficients depending upon the character of the sand. The volume of concrete from given quantities of cement, sand and stone may then be expressed by the formula:

$$Q = aC + bS + c(R - V),$$

in which  $c$  is a coefficient depending upon the amount of unfilled voids in the stone. For ordinary fairly coarse sands commonly

used for concrete,  $a$  may be taken .67 and  $b$  .77. For well compacted, plastic concrete of ordinary materials,  $c$  is about 1.10. With these values of the coefficients, the formula becomes:

$$Q = .67C + .77S + 1.1(R - V),$$

or

$$Q = C[.67 + .77s + 1.1r(1 - v)].$$

The volume of cement required to make a cubic yard of concrete is:

$$C = \frac{27}{.67 + .77s + 1.1r(1 - v)}.$$

The number of barrels of cement =  $C/4$ .

Cubic yards of sand =  $Cs/27$ ,

cubic yard of stone =  $Cr/27$ .

Table VI gives approximate quantities of materials required for 1 cubic yard of plastic concrete, using stone with differing percentages of voids. Average crusher run stone, with chips removed, has about 40 to 45 per cent voids; good natural gravel, screened, may have 35 to 40 per cent voids; mixed stone and gravel often runs from 30 to 35 per cent voids, while carefully graded materials may have voids reduced to from 20 to 30 per cent.

Variations in the characters of the materials used, and in the methods of handling and placing the concrete may vary considerably the quantities of materials required. Dry concrete, if thoroughly compacted by ramming, is more dense and occupies less space than plastic or wet concrete, but as ordinarily placed is more porous and occupies more space. Fine sand swells more when mixed with cement and water, and fills more space in plastic concrete, than coarse sand. Coarse broken stone compacts in concrete so as to leave less unfilled voids than smaller stone with the same per cent of voids. Poor work, such as irregular mixing or imperfect compacting, results in more porous concrete and requires less materials.

Tests of the yield of concrete may easily be made by mixing a batch in the proportions to be used and measuring the resulting concrete. In cases where accurate estimates of quantities are important and data concerning the particular materials are not at hand, such tests should be made.



TABLE VI. INGREDIENTS REQUIRED FOR ONE CUBIC YARD OF COMPACT, PLASTIC CONCRETE<sup>1</sup>

| PROPORTIONS BY VOLUMES. |       |        | 50 PER CENT VOIDS. |                  |                   | 40 PER CENT VOIDS. |                  |                   | 30 PER CENT VOIDS. |                  |                   | 20 PER CENT VOIDS. |                  |                   |
|-------------------------|-------|--------|--------------------|------------------|-------------------|--------------------|------------------|-------------------|--------------------|------------------|-------------------|--------------------|------------------|-------------------|
| Cement.                 | Sand. | Stone. | Cement,<br>Bbl.    | Sand,<br>Cu. Yd. | Stone,<br>Cu. Yd. | Cement,<br>Bbl.    | Sand,<br>Cu. Yd. | Stone,<br>Cu. Yd. | Cement,<br>Bbl.    | Sand,<br>Cu. Yd. | Stone,<br>Cu. Yd. | Cement,<br>Bbl.    | Sand,<br>Cu. Yd. | Stone,<br>Cu. Yd. |
| 1                       | 1     | 2      | 2.66               | 0.39             | 0.78              | 2.45               | 0.36             | 0.72              | 2.27               | 0.33             | 0.66              | 2.11               | 0.31             | 0.62              |
| 1                       | 1½    | 3      | 1.95               | 0.43             | 0.86              | 1.78               | 0.39             | 0.78              | 1.63               | 0.36             | 0.72              | 1.51               | 0.33             | 0.67              |
| 1                       | 1½    | 4      | 1.68               | 0.37             | 1.00              | 1.52               | 0.34             | 0.90              | 1.38               | 0.31             | 0.82              | 1.26               | 0.28             | 0.75              |
| 1                       | 2     | 3      | 1.75               | 0.52             | 0.78              | 1.61               | 0.48             | 0.72              | 1.49               | 0.44             | 0.66              | 1.39               | 0.41             | 0.62              |
| 1                       | 2     | 4      | 1.53               | 0.45             | 0.91              | 1.40               | 0.41             | 0.83              | 1.28               | 0.38             | 0.76              | 1.18               | 0.35             | 0.70              |
| 1                       | 2     | 5      | 1.36               | 0.40             | 1.01              | 1.23               | 0.36             | 0.91              | 1.12               | 0.33             | 0.83              | 1.02               | 0.30             | 0.76              |
| 1                       | 2½    | 4      | 1.41               | 0.52             | 0.84              | 1.29               | 0.48             | 0.76              | 1.19               | 0.44             | 0.70              | 1.10               | 0.41             | 0.65              |
| 1                       | 2½    | 5      | 1.26               | 0.47             | 0.94              | 1.15               | 0.42             | 0.85              | 1.05               | 0.39             | 0.77              | 0.97               | 0.36             | 0.71              |
| 1                       | 2½    | 6      | 1.15               | 0.43             | 1.02              | 1.04               | 0.38             | 0.92              | 0.94               | 0.34             | 0.83              | 0.86               | 0.32             | 0.76              |
| 1                       | 3     | 5      | 1.18               | 0.52             | 0.87              | 1.08               | 0.48             | 0.80              | 0.99               | 0.44             | 0.73              | 0.91               | 0.41             | 0.68              |
| 1                       | 3     | 6      | 1.07               | 0.48             | 0.96              | 0.97               | 0.43             | 0.87              | 0.89               | 0.39             | 0.79              | 0.82               | 0.36             | 0.73              |
| 1                       | 3     | 7      | 0.99               | 0.44             | 1.02              | 0.89               | 0.40             | 0.92              | 0.81               | 0.36             | 0.84              | 0.74               | 0.33             | 0.77              |
| 1                       | 3     | 8      | 0.91               | 0.41             | 1.08              | 0.82               | 0.36             | 0.97              | 0.74               | 0.33             | 0.88              | 0.67               | 0.30             | 0.80              |
| 1                       | 4     | 7      | 0.89               | 0.52             | 0.92              | 0.81               | 0.48             | 0.84              | 0.74               | 0.44             | 0.77              | 0.68               | 0.40             | 0.71              |
| 1                       | 4     | 8      | 0.83               | 0.49             | 0.98              | 0.75               | 0.44             | 0.89              | 0.68               | 0.40             | 0.81              | 0.63               | 0.37             | 0.74              |
| 1                       | 4     | 10     | 0.73               | 0.43             | 1.08              | 0.65               | 0.38             | 0.96              | 0.59               | 0.35             | 0.87              | 0.54               | 0.32             | 0.80              |

<sup>1</sup> One bag (94 pounds) of Portland cement is taken as a cubic foot, or one barrel of cement as four cubic feet.

## ART. 21. MIXING CONCRETE

**79. Preparation of Materials.**—In making concrete, the materials should be properly prepared and conveniently placed for use, as the labor cost of concrete work is largely a matter of arrangements for handling materials. The work should be systematized so that it goes forward smoothly, without loss of time in any of its parts.

*Broken stone* can usually be obtained within such range of sizes as may be desired. In preparing crushed stone, the crusher is set to the maximum size allowed, and the product varies from this size to dust. This product is then passed through rotary screens inclined at a small angle to the horizontal, which are made in sections of different sizes of openings, and admit of screening the stone into several sizes at one operation. When considerable quantities of materials are being used, the cost of handling the stone may not be materially increased by using several sizes and grading the aggregate. In any case where the aggregates available are badly graded, the advantage to be gained by grading them should be carefully considered.

The screened stone usually drops from the screens into bins, which are arranged so that the contents may be drawn off through chutes into cars or wagons for transportation to the work. The sizes and arrangement of the bins depend upon the need for storage and the kind of transportation. It is usually desirable that the bins be of sufficient size to equalize variations in the rate of use, or short delays in the crushing plant, so that work may proceed continuously.

*Gravel and sand* nearly always need to be screened. When considerable quantities are to be handled, and power for operating the screen is available, rotary screens are desirable, giving the most economical handling of the material, and admitting of division into required sizes.

In small work it is usual to employ hand screens, which are set up in an inclined position, and the material thrown against them with a shovel, the finer material passing through and the coarser sliding down to the foot of the screens. Sometimes two or more inclined screens are placed so that the material which passes one falls upon the one below, each being hinged so that its inclination to the horizontal may be adjusted.

Sand and gravel frequently require washing to remove dirt and fine material, which is often accomplished by supplying water in the chutes leading to the screens, the dirt being washed through a fine screen which retains the aggregate. Sometimes the material

is washed down a sloping trough, with a fine screen set in its bottom to permit the dirt to pass through. Portable plants for screening and washing are available in a number of forms, and often provide the most economical means of handling work of this kind. Wetting the material while in a pile, for the purpose of cleaning it, is useless.

Some storage of materials where the work is to be done is usually necessary, in order to have a supply which permits work to proceed continuously. The location of the materials with reference to the mixer, or mixing platform, should be carefully considered, as their convenience to the work affects the cost of mixing the concrete. The amount of storage should be as small as is consistent with assuring a continuous supply to the mixers.

**80. Hand Mixing.**—Concrete may be mixed by any method which will produce a homogeneous mass of uniform consistency. The arrangement of the work and methods of manipulating the materials in hand mixing vary greatly with the character of the construction and the ideas of the men in charge. The costs vary as widely as the methods.

*Measuring the Materials.*—Bottomless boxes are sometimes used for measuring the aggregates, the box being placed on the mixing platform, filled, and then removed, leaving the material on the platform—an accurate means of measuring, and desirable when it can be employed without materially increasing the cost of handling the aggregates.

Measuring in wheelbarrows is commonly employed, and frequently results in very irregular proportioning, as the barrow may not always be equally filled, unless special attention be given to the loading. When this method is employed, it is desirable to have barrows of such form that they may be evenly filled to level surface. When ordinary barrows are used, a bottomless box may be placed in the barrow, filled and removed, before starting with the load. It is worth while to use a method that will give accurate measurement, even at a small extra cost for labor.

Cement is measured by counting bags.

*The mixing* of concrete by hand should be done upon a water-tight platform. The cement and sand should first be mixed dry, being turned by shovels, or worked by hoes, until the mixture has uniform color. Water may then be added and the mixture worked into a rather soft mortar, after which the stone is wheeled or shoveled on top of the mortar and the whole turned with shovels until thoroughly mixed. When this method is followed the stone should be wet, to prevent taking the water from the mortar.



After mixing the sand and cement dry, the stone may be immediately distributed over the top of the mixture, water added, and the whole mixed by turning with shovels. In mixing concrete the shovels must be turned completely over and the contents deposited bottom side up. It is often difficult for workmen who have used shovels in other work to get the knack of doing this. Until they do, they accomplish very little.

Water should be poured on from buckets and care used to get only the quantity needed to properly mix the concrete. The quantity of water to be used depends upon the character of the work and manner of placing the concrete. An excess of water beyond that necessary to give a plastic consistency is always an element of weakness in the concrete.

Work of this kind always requires close supervision to see that all of the operations are properly performed and that the concrete produced is of uniformly good quality. Economy in hand mixing depends upon the work being so organized that it goes smoothly in all its parts, every man having his regular duties, and the number of men at each kind of work being such that one set of men does not have to stand idle waiting for others.

**81. Machine Mixing.**—Machinery is now used for mixing in practically all large concrete construction, and it is rapidly replacing hand mixing in much of the smaller work. Portable plants, which may readily be moved from place to place, are making this economically feasible. There are a large number of mixers on the market, differing more or less in their method of mixing the materials or in their mechanical appliances for handling materials.

*Rotating batch mixers* are either cubical boxes mounted to rotate about horizontal axes passing through two opposite corners, or cylindrical or conical drums rotating about their geometrical axes. The interior of the mixer is usually provided with blades, causing the materials to be thrown from one part of the mixer to another by the rotation. In using these mixers, the materials in proper proportions to form a batch of concrete are put into the hopper of the machine, and charged into the mixer at one time. The mixer is then run for a sufficient length of time to mix the ingredients, thoroughly and the concrete is drawn off through the outlet. The amount of water required should be determined, and measured for each batch. Automatic appliances for measuring water are provided on some machines.

The proportions of materials are under perfect control by this method, and the thoroughness of mixing may be insured by regulat-

ing the time of rotation for a batch. Examination of the concrete as it comes from the mixer will show whether it is thoroughly mixed and of proper consistency. Some operators try to speed the work by using more water than necessary and using less time in mixing. This diminishes the strength of the concrete and should not be allowed. The more thoroughly the concrete is mixed, the less the amount of water required to produce a given consistency, and thoroughly mixed materials flow better and have less tendency to separate in placing than those made soft by excess of water. In most cases the run should not be less than one minute properly to mix a batch. Some machines have devices for automatic control of the discharge to prevent shortening the time of mix.

*Paddle mixers*, consisting of a series of paddles mounted on a horizontal shaft, and working in a trough, are usually employed as continuous mixers. In these, the materials are fed in at one end, forced down the trough by the paddles, and discharged at the other end. These machines have not usually been so satisfactory as the batch mixers, on account of the lack of uniformity in supplying the materials. Some automatic feeding appliances have been found to work fairly well, and when the supply of ingredients can be evenly regulated these machines may do good work.

*Gravity mixers* are those in which the materials are mixed by falling through a vertical or inclined chute, and striking obstructions in the fall which throw them together. This mixer requires no power for operation, but the materials must be at a considerable elevation to provide the necessary fall.

The cost of machine mixing depends largely upon the appliances used in conveying the materials to and from the mixer and the method of feeding the mixer. The arrangement of a mixing plant must depend upon the character and amount of work to be done and the topography of the site. When the work is large and concentrated within a small area, a plant of permanent character may be erected with derricks or other mechanical appliances for handling the materials. Sometimes a plant of this kind is made semi-portable by erecting it on a framework resting upon wheels or rollers, which permit it being moved as the work progresses.

It is very common to have the mixer set so that it may discharge into barrows or carts on the ground, the materials being supplied by wheelbarrows from piles on the ground near the mixer. For this purpose, the rotary mixer, with movable hopper which may be let down to the ground for filling, is often used, portable plants mounted on wheels being very commonly of this type. Wheel-

barrows with the wheel under the body of the barrow, so that the barrow may be easily dumped over the wheel, are convenient for this kind of work.

In building construction, the mixer is commonly at the surface of the ground and supplied by barrows, the concrete being delivered at required elevations by bucket hoists.

## ART. 22. PLACING CONCRETE

**82. Transporting Concrete.**—The methods of handling concrete from the mixer to its final location vary with the size of the work and the consistency of the concrete.

For small work and short distances, wheelbarrows are commonly used. Ordinary contractors' barrows carry from about 1.8 to 2.0 cubic feet at a load. For longer hauls, two-wheeled barrows, carrying about 6 cubic feet, are more economical. On large work, cars running on temporary tracks are frequently employed, or when the work is within a short radius, derricks may be used. In building operations concrete is frequently raised by a bucket hoist to the required elevation and distributed by barrows to the various parts of the work.

These methods of handling, in which a small bulk of the concrete is held together in transportation and dumped at once into place, offer little opportunity for the ingredients of the concrete to separate. Well-mixed concrete of any proper consistency may be transported to considerable distances without being injured. Concrete that is so dry as to lack cohesion, or concrete that is so wet that the mortar is soft enough to run away from the stone, shows a tendency to separation in handling, and these consistencies should not be used.

*Transportation in Chutes.*—The distribution of concrete is sometimes effected by elevating it sufficiently to permit it to flow in a trough or chute to its destination, and by arranging a system of movable chutes it is often possible to distribute over considerable area from a single hoisting tower. When the mixer can be set above the work, as in foundations or sometimes in dams and similar structures, the concrete may be transported wholly by gravity.

To flow in chutes, rather soft, mushy concrete is necessary, unless the chutes are quite steep. When the slope of the chute is very flat, the concrete must be made very wet, and does not result in first-class work, while the extra water necessary to make the concrete flow on a flat slope causes the mortar to separate from the stone, and frequently washes portions of the cement from the



mortar. The practice of adding water in the chutes to assist the flow is always detrimental.

Experience indicates that concrete may be made to flow readily in chutes on slopes from about  $20^{\circ}$  to  $35^{\circ}$  to the horizontal; for any slope less than about  $20^{\circ}$ , the concrete must be made too wet. The mass of concrete should slide along the chute as a whole, the stone and mortar traveling together at common velocity. For ordinary mushy concrete, as commonly used in reinforced work, a slope of 2 horizontal to 1 vertical is found most efficient.

*Pneumatic Transportation*, by forcing the concrete through pipes by compressed air, has been used in some instances—a method available on congested work, where space is lacking for other means of transport, as in tunnel and subway work.<sup>1</sup>

**83. Depositing Concrete.**—When concrete is mixed dry (the consistency of damp earth) and placed in mass construction, it is usually placed in layers about 6 inches deep and each layer tamped until the mortar flushes to the surface. Concrete so mixed and placed attains greater strength than if mixed with more water. If dry concrete is not tamped so as to be thoroughly compacted, it is more porous and has less strength than wet concrete; the labor required in properly placing dry concrete is considerable and the work strenuous, so that for ordinary uses dry concrete is not commonly employed. Poor work has frequently resulted from the use of dry concrete not properly compacted.

In ordinary practice concrete is mixed either to a rather stiff plastic condition or to a softer mushy consistency. Plastic concrete, when in massive work, should be spread in layers not more than 10 or 12 inches deep and lightly rammed; the mortar should readily flush to the surface and the mass quake like jelly under the ramming. The rammer is usually a flat piece of iron about 6 inches square, with a vertical handle, and weighing 15 to 20 pounds. Smaller tapering rammers are also used for compacting next to the forms.

Mushy concrete may be deposited in somewhat thicker layers, being lightly tamped or worked with rammers of small section, usually about 2x3 inches, for the purpose of eliminating air bubbles and making sure that there are no open spaces unfilled with mortar. A flat spade is commonly run down next to the form to bring the mortar to the surface and prevent voids which often occur where the stones of the concrete are in contact with the form.

<sup>1</sup> See *Engineering and Contracting*, March 17, 1915, or *Engineering News*, March 16, 1916.

*Laitance.*—In the use of very soft concrete, when an excess of water is used, there is a tendency for certain parts of the cement to be taken up by the surplus water and deposited on the upper surface of the concrete as a sort of light-colored slime, which is known as laitance. Its formation involves a loss of cement in the concrete and, if left in the body of the concrete, it forms a plane of weakness in the mass of concrete. Laitance is often found to an objectionable extent when very wet concrete is chuted to place, and deposited in masses of considerable vertical thickness. A column of wet concrete poured through chutes may have a cap of laitance 2 or 3 inches thick which must be removed.

*Bonding to Old Work.*—Joints must frequently be made with work previously placed. In massive work, subjected only to compressive stresses normal to the joints, the surface of the old concrete must be clean and should be wet before the placing of the new concrete. In work where the strength of the bond of the new to the old work is of special importance, the old work should be cleaned, all laitance removed, the skin on smooth surfaces broken by scarifying, and the surface thoroughly wet. A coating of cement paste will then aid the bond with the new work.

Joints between different days' work should be carefully located where they will be least injurious to the strength of the structure. When feasible it is desirable to divide a structure into integral parts, each of which may be constructed without stopping the work.

*Depositing under Water.*—Concrete work for under-water construction is sometimes done by passing the mixed concrete through the water to the desired position. It is common to use a tremie for this purpose. This consists of a tube or closed chute, which is kept full of concrete so that the water has no chance to wash the concrete as it passes downward. The bottom of the tremie is moved about over the surface upon which the concrete is being deposited, so that the concrete does not fall through the water. Concrete for this purpose must be quite wet, in order to flow readily to place without being washed by the water through which it is passing.

Buckets, which are filled with concrete, lowered through the water, and dumped by opening the bottom when in contact with the surface upon which the concrete is to be placed, are also sometimes used for under-water work. The method of enclosing the concrete in bags and placing these in contact with each other has also been used for this purpose.

**84. Placing Concrete in Freezing Weather.**—The setting and hardening of concrete are greatly retarded at low temperatures; in

cold weather much longer time is needed to gain strength, and forms must be left longer before removal. Accidents have sometimes occurred to concrete structures through premature removal of forms, on account of failure to consider the influence of temperature upon the rate of hardening. At 40° F., the time required to gain a given strength is two or three times as long as at 70° F.; below 40° F., the required time rapidly increases as the temperature is lowered.

Cement mortar or concrete made and frozen before it has time to set is uninjured by freezing and sets and hardens properly after it thaws out. If the mortar is frozen when partially set or soon after it has set and before any considerable strength has been gained, the expansion caused by freezing breaks the bond and destroys the cohesion of the mass, causing it to crumble upon thawing out.

The use of concrete in freezing weather, except in large masses, should be avoided in so far as possible. When it is necessary to place concrete at freezing temperature, or when it is likely to be frozen soon after placing, extreme care should be taken to minimize the probable effect of freezing upon the concrete. The methods employed may be intended to hasten the setting and hardening of the cement, to prevent the concrete from freezing soon after placing, or both, and for this purpose, materials may be selected that will act quickly when made into mortar. Quick-setting cements, however, are sometimes more retarded by low temperatures than others setting more slowly at normal temperatures. In selecting materials, it is more important to get those acquiring strength quickly than those setting quickly.

*Heating the Materials*, and mixing and placing them warm, has the effect of hastening the hardening processes, and also prevents immediate freezing. If the temperature is but little (3° or 4°) below the freezing-point, heating the materials and placing the concrete warm may be sufficient to prevent injury from freezing. Protection should also be given the concrete to delay freezing as long as possible. The materials should not be at a temperature much above 100° or 110° F. at the time of mixing. The use of hot water is injurious to the cement, and may defeat the object of heating by preventing the cement setting properly.

Having placed the concrete while warm, if the temperature is likely to be more than 3° or 4° below the freezing-point, it is necessary to have some means of keeping the work from freezing on the surface, which may sometimes be done by enclosing the work in some way and using small stoves, or steam pipes may be available for heating small enclosed spaces. In placing work in large masses,



the heat of chemical action will prevent freezing in the body of the work, but exposed surfaces must be protected.

*Use of Salt.*—When the temperature is but little below the freezing-point, the freezing of concrete may be prevented by dissolving salt in the water used for mixing. A small addition of salt (3 to 5 per cent of the weight of water) lowers the freezing-point of the concrete, and prevents injury from freezing at temperatures perhaps 5° or 6° below freezing. The salt also has the effect of somewhat increasing the rapidity of hardening, which is very slow at such temperatures.

Salt is sometimes used in larger proportion, 10 to 15 per cent of the weight of water, to prevent freezing at lower temperatures. This seems to retard hardening, and is considered by some engineers to be harmful to the concrete.

**85. Contraction Joints.**—Cement mortar and concrete expand and contract with changes of temperature in the same manner as other materials. They also change in dimension with changes in moisture, expanding when wet and contracting when dry.

*Temperature Changes.*—The coefficient of expansion of concrete has been found by various investigators to vary from about .0000050 to .0000065 per degree F., the average result being about .0000055 per degree F., or .0000099 per degree C. If the coefficient of elasticity of the concrete is 2,000,000, this would be sufficient to produce a unit stress in the concrete of 440 lb./in.<sup>2</sup>, for a change of temperature of 40° F. if the concrete be restrained from yielding.

Concrete in large masses frequently reaches a high temperature during the period of early hardening, due to the heat produced by the chemical changes taking place, temperatures of from 95° F. to 150° F. having been observed.<sup>1</sup> In thin walls this is largely counteracted by the radiation into the atmosphere. The influence of changes of atmospheric temperatures rapidly decreases with the distance from the surface of the concrete. Daily variations of temperature are not felt at depths of more than 2 or 3 feet, while seasonal variations may not reach more than one-third the amount of the change in the outside air at a depth of 10 feet.

*Moisture Changes.*—Variations in moisture conditions are of greater importance than those of temperature in causing mortar or concrete to expand and contract. These changes are of special importance during the time that the concrete is hardening. Experiments indicate that concrete kept in dry air during the period of

<sup>1</sup> Temperature Changes in Mass Concrete, by Paul and Mayhew, Transactions, American Society of Civil Engineers, Vol. LXXIX, 1915, p. 1225.

hardening undergoes a progressive shrinkage, while that kept in water expands during the same period, but to a less extent. The results obtained by different investigators have varied considerably in the extent of the changes shown. In general, concrete exposed to dry air may be expected to contract .04 to .06 per cent of its length in six months after mixing, while if kept under water it may expand .01 to .02 per cent. The changes for cement mortar are greater than for concrete, the extent of the change being greater as the mortar is richer.

Tests indicate that concrete at any age expands if changed from dry to wet condition, and contracts if changed from wet to dry. Concrete subject to changes in moisture conditions, therefore, alternately expands and contracts with such changes, unless restrained by its position from such motion. We have no means of estimating the amount of the variations to be expected in concrete work, but under ordinary conditions these effects must be much less than the progressive variations during hardening.

Available data are not sufficient to determine to what extent the progressive expansions or contractions taking place during hardening may be permanent.<sup>1</sup> Indications are that concrete which has been kept wet during the first month or more and then permitted to dry for several months, does not shrink to the same extent as that which is kept dry during the whole period. Concrete kept damp during the early period of hardening should not crack when exposed to the air to the same extent as that continuously dry.

It seems probable that under some conditions progressive changes in dimension may take place over a long period, though it must not be inferred that work in which the concrete is restrained from such changes is subjected to the stresses which would be imposed by the necessity of resisting them all at once. Concrete restrained, as in reinforced work, from yielding to the tendency to contract, probably becomes adjusted to the situation so that it would not contract if the restraint were removed.

*Contraction joints* are commonly used to prevent the cracking of concrete by shrinkage. The compressive strength of concrete is usually sufficient to take up the stresses due to expansion without injury to the structure, but tensions due to contraction may be sufficient to crack the concrete.

<sup>1</sup> See, "Expansion and Contraction of Concrete While Hardening," by A. T. Goldbeck, Proceedings, American Society for Testing Materials, Vol. XI, p. 563, also, "Volume Changes in Portland Cement Mortar and Concrete," by A. H. White, Proceedings, American Society for Testing Materials, Vol. XIV, p. 203.

Thin concrete walls usually need contraction joints 20 to 30 feet apart; in heavy walls, they may be 50 or 60 feet apart. The use of light reinforcement in the exposed surfaces between expansion joints may prevent disfiguring surface cracks.

Ordinarily these joints may be formed by building the work in sections and allowing one section to set before the adjoining one is placed. This introduces planes of weakness through the work which will yield when the wall contracts. To bond the ends together, grooves may be left in the sections first constructed and filled in placing the new work. Joints are sometimes made by inserting strips of roofing paper and placing the new concrete against these, or where water-tight work is necessary by filling a thin opening in the concrete with asphalt cement.

**86. Finishing Concrete Surfaces.**—The appearance of a concrete structure depends largely upon the way in which the surfaces are finished. When the forms are removed, the marks of the lumber of the forms are plainly visible, and lines between successive layers of concrete are usually seen. When the concrete next the form has been carefully spaded in placing the concrete, the surface should be fairly smooth with no vacant spaces which require filling, and if the forms are smooth, a quite even, uniform appearance may be obtained. For certain classes of structures, such as retaining walls and bridge abutments in certain locations, the appearance may be satisfactory without further treatment, although the dead color of the smooth surface skin is not particularly pleasing.

A smooth surface is sometimes obtained by plastering with cement mortar—a method not usually satisfactory, as the mortar is apt to scale off. A rough appearance is usually more suitable to the material, and the surface of the concrete itself should be used. When a smooth mortar surface is desired, it should be obtained by placing the mortar at the same time as the concrete, which may be done by using a movable form for the mortar. The form slides inside the main form and separates the mortar from the concrete, and is removed as the materials are placed so that they may be tamped together.

A pleasing appearance may often be made by scrubbing the surface with a stiff brush and water as soon as it has set sufficiently to remove the forms, which removes the marks of the forms and brings the pieces of larger aggregate into view. Scrubbing must be done before the concrete has hardened too much, usually within twenty-four hours of placing the concrete, and immediately after removing the forms, as the surface hardens rapidly after the forms



are taken off. In removing forms for this purpose, care must be used to prevent breaking the corners of the concrete, as, to present a good appearance, the edges must be straight and sharp. Scrubbing involves comparatively little labor and is an inexpensive method of finishing.

After the concrete surface is hard it may be scrubbed, and the skin removed, by the use of a solution of about one part hydrochloric acid to five parts water, though this method is quite laborious and rather expensive.

Concrete surfaces are sometimes finished by tooling, using the axe, bush-hammer, or point. The concrete may thus be made to show a very uniformly roughened surface which is very pleasing. If neatly done, this is rather slow and expensive, although a roughly pointed effect may be produced with less work.

The appearance of the finished surface may be controlled by the choice of aggregates. If a uniform appearance is desired, small aggregates may be used on the surface. If a more rough appearance is wanted, larger and less uniform material may be employed. Pleasing color effects may often be had by care in the choice of aggregates to be used on the surface, or mortar colors may be used for the purpose. White Portland cement may also be used where special effects are desired.

Breaking the continuity of a surface by introducing panels may frequently improve its appearance. These are made by nailing boards of proper shape to the inside of the forms. The surface may be broken by lines indented into the concrete by nailing strips of triangular section to the inside of the forms.

#### ART. 23. WATERTIGHT CONCRETE

**87. Permeability of Concrete.**—The permeability of a wall of concrete varies with the size and shape of the aggregates, the density of the mixture, and the richness of the mortar. For given aggregates, the densest and strongest mixture will usually be the least permeable, although the least porous concrete is not necessarily the least permeable when different materials are used.

Mortar composed of fine sand is more porous and less permeable than mortar of coarse sand mixed in the same proportions. Graded sand, with sufficient fine materials, shows less porosity and less permeability than either fine or coarse sand alone, but with any sand, the permeability of mortar decreases as the ratio of cement to sand increases.

The permeability of mortar decreases with age during the period of hardening, and mortar subject to the continuous filtration of water decreases in permeability. Messrs. Fuller and Thompson<sup>1</sup> found that the permeability of concrete decreased as the maximum size of coarse aggregate increased, and that gravel concrete was less permeable than that made with broken stone.

The use of sand cement (see Section 16) in place of Portland cement ordinarily gives a somewhat more impervious concrete, and is frequently used for the purpose. The extremely fine grinding to which the cement is subjected in preparing the sand cement is favorable to making a water-tight mortar.

*Water-proof Concrete.*—With carefully selected and proportioned materials and good workmanship, concrete may be made practically water-tight. To secure this result, rich mortar (at least 1 to 2) should be used, and the aggregates graded to produce a dense mixture. The concrete should be thoroughly mixed to a plastic or soft, but not too wet, consistency, and placed carefully, eliminating joints if possible. When horizontal joints are unavoidable, the skin on the old surface should be broken and roughened before placing the cement paste to receive the new work. A thickness of 1 foot of well-constructed concrete wall may be expected to be practically water-tight, under a head of 50 feet. No wall to hold water pressure should be less than 6 inches thick.

When a lean concrete is used for the body of the work, a thin surface of rich concrete, or of cement mortar, may be placed upon the water face; this face must be built up with the main body of the work and firmly united with it, and contraction joints must be used where cracks are likely to occur.

*Tests for Permeability.*—The permeability of concrete is tested by forcing water through a block of concrete under pressure, the block being so arranged that the water can escape only by passing through the concrete. In an apparatus used by Mr. Thompson<sup>2</sup> for this purpose the sides of the mold were made by two pieces of wrought iron bent to a half-circle and bolted together, these resting on a plank which formed the bottom of the mold until the concrete had set. The surfaces of the concrete were chipped to remove the skin, the blocks turned upside down in making the tests, and the water measured which passed through the block.

**88. Integral Waterproofing.**—For the purpose of increasing the water-tightness of concrete, additions of other materials are some-

<sup>1</sup> Transactions, American Society of Civil Engineers, Vol. LIX, 1907, p. 67.

<sup>2</sup> Proceedings, American Society for Testing Materials, Vol. VIII, p. 506.

times made. There are a number of proprietary compounds on the market to be mixed with the concrete to make it impervious, known as integral water-proofing compounds. Some of these may be of value, provided they are not used in lieu of proper proportions or good work in placing the concrete, but dependence upon making meager or improperly mixed concrete water-tight by additions of waterproofing compounds is apt to end in failure.

*Hydrated Lime.*—The addition of hydrated lime to the cement mortar used in concrete may be useful in assisting in making the concrete water-tight. As already noted (Section 35), mortar containing lime works easier, and is preferred by masons for brickwork (Section 60). A small addition of hydrated lime makes concrete flow more readily in placing and tends to prevent separation of the materials in handling, and it is sometimes used for this reason in concrete which is to be chuted to place.

Hydrated lime may be used in cement mortar to replace a small per cent by weight of the cement without injury to the strength of the mortar. It is a very finely divided material, much more bulky than the cement, and therefore renders the mortar less permeable. Where the strength is sufficient, a somewhat leaner concrete may be used if hydrated lime is added. Experiments by Mr. Thompson<sup>1</sup> show that hydrated lime may be of considerable value in rendering concrete impervious under considerable heads. Mr. Thompson recommends the addition of hydrated lime in the following percentages of weight of dry hydrated lime to the weight of Portland cement:

For 1 part Portland cement; 2 parts sand; 4 parts stone, add 8 per cent hydrated lime.

For 1 part Portland cement;  $2\frac{1}{2}$  parts sand;  $4\frac{1}{2}$  parts stone, add 12 per cent hydrated lime.

For 1 part Portland cement; 3 parts sand; 5 parts stone, add 16 per cent hydrated lime.

*Clay.*—Finely divided clay in the sand used in making concrete has been found to lessen the permeability of the concrete. The clay must be free from vegetable matter and present in small proportion, not more than 5 per cent of the weight of sand. Finely pulverized rock has much the same effect. These materials are of use when the mortar is lean, though for rich mortars they may be detrimental to strength without materially affecting the permeability.

*Alum and soap solution* has sometimes been used to mix with the body of concrete and seems to have been fairly efficient as a

<sup>1</sup> Proceedings, American Society for Testing Materials, Vol. VIII, p. 500.



water-proofing medium. In applying, it is usually best to mix powdered alum with the cement and dissolve the hard soap in the water to be used in mixing. The soap may be about 3 per cent of the weight of water, and the alum about one-half the weight of the soap.

*Oil-mixed Concrete.*—It has been proposed to use mineral oil as an integral water-proofing. The results of experiments by Mr. Page<sup>1</sup> indicated that the use of a small amount of asphaltic oil in mixing cement mortar decreased the permeability of the mortar, without materially decreasing its strength. He found the crushing strength to be somewhat reduced, when the weight of oil was 10 per cent that of the cement the crushing strength was reduced about 25 per cent.

The lubricating effect of the oil is such that it cannot be used for reinforced work with plain steel bars.

The oil recommended by Mr. Page is a fluid petroleum residual, and he suggests the use of 5 per cent of the weight of cement for water-proofing purposes.

**89. Waterproof Coatings.**—Various methods have been proposed and are sometimes used for the treatment of concrete surfaces to make them waterproof. For ordinary work, as already stated, the concrete may itself be made water-tight and nothing is needed beyond care in the selection of materials and in preparing and placing the concrete. Under some circumstances, however, as in old work or where joints and cracks cannot be avoided, it may be necessary to provide some means of protecting the surface of concrete against the penetration of water.

*Layers of Waterproof Materials.*—Probably the most effective method of protection is that of applying layers of waterproof paper or felt coated with asphalt or coal-tar pitch. The concrete is first coated with hot asphalt, layers of paper or felt are then placed, and each coated with the hot asphalt, the applications being made from 3-ply to 6-ply, depending upon the degree of protection needed—a method frequently employed on subways, and bridge floors with good results. Objection has been made to this method on account of it preventing the radiation of heat in subway work. Careful workmanship is necessary in placing such a protection; the layers must break joints properly, and be protected against being punctured after being placed.

*Cement Grout.*—Washing the surface of concrete with a grout of

<sup>1</sup> Oil-Mixed Portland Cement Concrete, Bulletin No. 46, Office of Public Roads, Washington.

neat Portland cement may sometimes be of use on a surface exposed to water, serving to fill voids and cracks which may exist in the surface.

*Plastering* with cement mortar, or other materials mixed with cement, is sometimes adopted as a means of waterproofing. Usually such plastering needs protection against possible weather cracks, and sometimes the plaster does not adhere. On horizontal or inclined surfaces a troweled mortar finish, similar to that commonly used on sidewalks, makes a water-tight job, provided care be taken to guard against cracks, and to insure the bonding of the mortar to the concrete.

*Alum and Soap.*—A solution of soap and alum is often used to wash the surface of concrete; it is of the same character as the mixture employed in integral waterproofing, and is also sometimes used for mixing with cement mortar for plastering the surface.

Bituminous coatings consisting of one or more coatings of asphalt or tar painted on hot are sometimes employed, such applications being often used on the outside of the cellar walls of buildings. A number of proprietary compounds are available for use as surface washes, some of which seem quite effective, though in many cases they require renewal from time to time. Some interesting tests of a number of methods of waterproofing concrete surfaces were made by Mr. F. M. McCullough, and the results given in Bulletin No. 336 of the University of Wisconsin, on "Tests of the Permeability of Concrete."

#### ART. 24. DURABILITY OF CONCRETE

**90. Destructive Agencies.**—Well-constructed concrete, under the conditions usually met in ordinary work, is practically an indestructible material, but under special conditions, when subject to the action of agencies peculiar to particular classes of work, concrete may yield like any other material. The cracking of concrete through contraction, as explained in Section 85, may be of injury to a structure, but the body of concrete itself is not destroyed or disintegrated by cracking.

Concrete has sometimes seemed to be injured by the action of certain chemical agencies, such as oils, salts of sea water, alkalies, and acids. Destruction by electrolysis and by fire have also sometimes occurred.

*Effect of Oils.*—Mineral oils have no ill effects upon concrete, and have sometimes been used for the purpose of rendering the

surface less pervious, and to prevent dust upon surfaces subject to abrasion. Some animal fats and vegetable oils seem to cause disintegration in concrete. When such oils at high temperatures come into contact with concrete, a combination of lime from the cement with acids contained in the oils produces compounds which expand when crystallizing in the pores. In manufacturing plants, where animal or vegetable oil may come into contact with concrete, the effect of such contact should be carefully investigated.

*Effect of Acids.*—Water containing acids should not come into contact with concrete before it has well hardened. Hard concrete may resist the action of such solutions unless they are in rather concentrated form. The effect of any destructive agency of this character will be much greater for porous concrete into which the liquid may readily penetrate than for dense concrete.

*Electrolysis.*—In some instances, injury to concrete containing steel reinforcement has resulted from the leakage of electric currents through the mass. The Joint Committee on Concrete in its 1917 report make the following statements concerning electrolysis:

*Electrolysis.*—The experimental data available on this subject seem to show that while reinforced concrete structures may, under certain conditions, be injured by the flow of electric current in either direction between the reinforcing material and the concrete, such injury is generally to be expected only where voltages are considerably higher than those which usually occur in concrete structures in practice. If the iron be positive, trouble may manifest itself by corrosion of the iron accompanied by cracking of the concrete, and, if the iron be negative, there may be a softening of the concrete near the surface of the iron, resulting in a destruction of the bond. The former, or anode effect, decreases much more rapidly than the voltage, and almost if not quite disappears at voltages that are most likely to be encountered in practice. The cathode effect, on the other hand, takes place even under very low voltages, and is therefore more important from a practical standpoint than that of the anode.

Structures containing salt or calcium chloride, even in very small quantities, are very much more susceptible to the effects of electric currents than normal concrete, the anode effect progressing much more rapidly in the presence of chlorine, and the cathode effect being greatly increased by the presence of an alkali metal.

There is great weight of evidence to show that normal reinforced concrete structures free from salt are in very little danger under most practical conditions, while non-reinforced concrete structures are practically immune from electrolysis troubles.

**91. Effect of Sea Water upon Concrete.**—There have been numerous instances of failure of concrete subject to the action of sea water, the causes of which are not fully determined. The results of experiments seem to indicate that salts contained in sea water act upon nearly all cements to which the water has free access,



producing compounds which expand, disrupting the mass of mortar, or which soften the mortar and cause disintegration. This action is probably due to sulphates in the sea water, which are decomposed in contact with the free lime of the cement, the sulphuric acid combining with the lime. A considerable deposit of magnesia also commonly occurs in cement mortar when exposed to sea water,<sup>1</sup> indicating that the sulphate of magnesia may be the source of the trouble.

Those cements which contain the most lime are usually most affected by the action of sea water. Cements containing considerable alumina should not be used for work in sea water, siliceous cements, or those in which alumina is replaced by iron oxide being preferable. In France a siliceous hydraulic lime known as lime of teil is extensively used for such work.

The addition of finely ground puzzolanic materials to Portland cement has been found useful in preventing the disintegrating effects of sea water. These materials probably combine with and reduce the amounts of free lime available for combination with the sea salts. As used, they also render the mortar less permeable.

Mortars of fine sand are found to be more affected by sea water than those of coarse or graded sands.

The injurious action of sea water is dependent upon the water having access to the body of the concrete, hence it is important in such work to use concrete of maximum density, or to protect the body of the concrete by a surface of dense mortar or concrete. The Joint Committee on Concrete in its 1917 report makes the following reference to work in sea water:

The data available concerning the effect of sea water on concrete or reinforced concrete are limited and inconclusive. Sea walls out of the range of frost action have been standing for many years without apparent injury. In many places serious disintegration has taken place. This has occurred chiefly between low and high tide levels and is due, evidently, in part to frost. Chemical action also appears to be indicated by the softening of the mortar. To effect the best resistance to sea water, the concrete must be proportioned, mixed and placed so as to prevent the penetration of sea water into the mass or through the joints. The aggregates should be carefully selected, graded and proportioned with the cement so as to secure the maximum possible density; the concrete should be thoroughly mixed; the joints between old and new work should be made watertight; and the concrete should be kept from exposure to sea water until it is thoroughly hard and impervious.

<sup>1</sup> Alexandre, *Annales des Ponts et Chaussées*, 1890, Vol. I, p. 408. Candlot, *Ciment et Chaux Hydraulique*, Paris, 1891. Feret, *Annales des Ponts et Chaussées*, 1892, Vol. II, p. 93.

**92. Effect of Alkalies.**—In some localities in the arid regions of the Western States difficulty has been met in the use of concrete because of the disintegrating effects of alkaline waters—effects similar to those of sea water and probably due to the same causes. The most serious disintegration is found where the concrete is alternately wet and dry, although in some cases the whole of the concrete below water has been affected.

On many irrigation projects large quantities of concrete are being used, and the problem of dealing with the alkaline salts, with which the soil is impregnated in some localities, has become a serious one. These alkaline deposits vary in character in different places, comprising salts of potassium, sodium, calcium, and magnesium. The ill effects seem to occur where sulphates are present in considerable quantities,<sup>1</sup> which agrees with the results of studies of the action of sea water. The same precautions may be taken in selection of materials as for work in sea water, but all cements seem to be affected to some extent by contact with these salts. The use of dense concrete, or the application of protective coatings to prevent access of the alkaline water to the interior of the mass of concrete, offers the best means of preventing disintegration.

**93. Resistance to Fire.**—Experience indicates that concrete, when properly used, is one of the best materials for resisting fire. The surface of concrete immediately exposed to the fire is injured and may become dehydrated, but concrete is a poor conductor of heat, and the penetration of the dehydrating effect is extremely slow. Experiments by Professor Woolson<sup>2</sup> show that when a mass of concrete is subjected to high heat for several hours, the temperature 1 inch beneath the surface is several hundred degrees below that at the surface. With the temperature of 1500° F. at the surface for two hours, the temperature at 2 inches beneath the surface was from 500° to 700° F., and at 3 inches beneath the surface about 200 to 250° F.

When concrete is used as structural material, where it is liable to be subjected to serious fire risk, a layer of concrete next the exposed surface should be considered as fireproofing and not included in the section necessary for resisting stresses.

The Joint Committee in its report of 1917 discusses fireproofing as follows:

Concrete, because incombustible and of a low rate of heat conductivity, is

<sup>1</sup> J. Y. Jewett, Proceedings American Society for Testing Materials, Vol. VIII, 1908, p. 484.

<sup>2</sup> Proceedings, American Society for Testing Materials, Vol. VII, 1907, p. 408.

highly efficient and admirably adapted for fire-proofing purposes. This has been demonstrated by experience and tests.

The dehydration of concrete probably begins at about 500° F. and is completed at about 900° F., but experience indicates that the volatilization of the water absorbs heat from the surrounding mass, which, together with the resistance of the air cells, tends to increase the heat resistance of the concrete; so that the process of dehydration is very much retarded. The concrete that is actually affected by fire and remains in position affords protection to that beneath it.

The thickness of the protective coating should be governed by the intensity and duration of a possible fire and the rate of heat conductivity of the concrete. The question of the rate of heat conductivity of concrete is one which requires further study and investigation before a definite rate for different classes of concrete can be fully established. However, for ordinary conditions it is recommended that the metal be protected by a minimum of 2 inches of concrete on girders and columns, 1½ inches on beams, and 1 inch on floor slabs.

Where fireproofing is required and not otherwise provided in monolithic concrete columns, it is recommended that the concrete to a depth of 1½ inches be considered as protective covering and not included in the effective section.

The corners of columns, girders, and beams should be beveled or rounded, as a sharp corner is more seriously affected by fire than a round one; experience shows that round columns are more fire resistive than square.

#### ART. 25. STRENGTH OF PLAIN CONCRETE

**94. Compressive Strength.**—There are several variables which affect the strength of concrete. The quality and quantity of cement, the kind of aggregates and their grading, the proportions of fine to coarse aggregate, the thoroughness of mixing, the consistency, the degree of compacting, and the conditions under which hardening takes place, all have an influence upon the strength of the resulting concrete.

Thorough mixing and careful placing and compacting of the concrete should be obtained in all work. Carelessness always reduces its strength, and is wasteful and unnecessary.

The Joint Committee on Concrete recommends that the materials be proportioned to secure as nearly as possible a maximum density. "The fine and coarse aggregates should be used in such proportions as will secure maximum density. These proportions should be carefully determined by density experiments and the grading of the fine and coarse aggregates should be uniformly maintained, or the proportions changed to meet the varying sizes." They also recommend that "the materials be mixed wet enough to produce a concrete of such consistency as will flow sluggishly into the forms, and about the metal reinforcement when used, and which, at the same time, can be conveyed from the mixer to the forms without separation of the coarse aggregate from the mortar."



For such concrete, the Committee suggests the following values of ultimate strength in compression as those which should be obtained for the materials and proportions listed. the ratios given being those of cement to the volumes of fine and coarse aggregates measured separately. This ultimate strength is that developed at an age of twenty-eight days, in cylinders 8 inches in diameter and 16 inches long of the consistency described above, made and stored under laboratory conditions.

TABLE OF COMPRESSIVE STRENGTHS OF DIFFERENT MIXTURES OF CONCRETE

(In Pounds per Square Inch)

| Aggregate.  | 1 : 3 | 1 : 4½ | 1 : 6 | 1 : 7½ | 1 : 9 |
|---|-------|--------|-------|--------|-------|
| Granite, trap rock . . . . .                        | 3300  | 2800   | 2200  | 1800   | 1400  |
| Gravel, hard limestone and hard sandstone . . . . . | 3000  | 2500   | 2000  | 1600   | 1300  |
| Soft limestone and sandstone . . . . .              | 2200  | 1800   | 1500  | 1200   | 1000  |
| Cinders . . . . .                                   | 800   | 700    | 600   | 500    | 400   |

## BEARING

When compression is applied to a surface of concrete of at least twice the loaded area, a stress of 35 per cent of the compressive strength may be allowed in the area actually under load.

## AXIAL COMPRESSION

For concentric compression on a plain concrete pier, the length of which does not exceed 4 diameters, or on a column reinforced with longitudinal bars only, the length of which does not exceed 12 diameters, 22.5 per cent of the compressive strength may be allowed.

Allowable stresses for concrete in reinforced work are given in Chapter VI.

*Cement.*—The strength of concrete varies nearly in proportion to the cement contained by it, and the ratio of cement to aggregate should be selected to give the strength needed in the particular work in hand.

The Committee suggests:

For reinforced concrete construction, one part cement to a total of six parts of fine and coarse aggregates measured separately should generally be used. For columns, richer mixtures are preferable. In massive masonry or rubble concrete a mixture of 1 : 9 or even 1 : 12 may be used.

These proportions should be determined by the strength or other qualities required in the construction at the critical period of use. Experience and judgment based on observation and tests of similar conditions in similar localities are excellent guides as to the proper proportions for any particular case.

*Size of Aggregate.*—The values given above are suggested for concrete as used in reinforced work and correspond to materials broken to rather small maximum sizes. Stones of larger maximum dimensions ordinarily show somewhat higher strengths. A stone broken to 2½-inch maximum size will sometimes show strength 20 to 35 per cent higher than the same stone broken to 1-inch maximum size, if both be properly graded.

*Consistency.*—The mushy consistency recommended in the report of the Committee is most convenient for ordinary use in concrete work, particularly in reinforced work. In massive work, a stiffer plastic consistency gives a slightly higher strength if the concrete is properly compacted in placing. The strength rapidly decreases as the quantity of water is made greater, so that the materials begin to separate and considerable laitance forms.

Strength is gained more slowly by concrete mixed wet than by that mixed with less water. A stiff plastic concrete may have considerable more strength at seven days than a wetter mushy concrete though the difference will have largely disappeared in twenty-eight days.

*Growth in Strength.*—It is customary to use the strength at twenty-eight days in fixing the stresses to be allowed on concrete in structures. This strength would usually be attained before maximum loads could be applied. The strength of concrete under normal conditions continues to increase through a considerable period. Tests have shown that average concrete may be expected to reach about twice the twenty-eight-day strength in two or three years if kept from becoming too dry. Specimens kept dry show a considerably smaller increase, and may ultimately gain but little more than the twenty-eight-day strength.

*Grading of Aggregates.*—With the same ratio of cement to total aggregates, the strength of concrete is greater when the aggregates are graded to give more dense mixtures. The amount of cement required to give a definite strength is less for well-graded aggregates than for those giving more porous concrete. In some instances it is possible, by sifting the aggregates into several sizes and recombining in proper proportions, to reduce considerably the quantity of cement necessary to reach the required density and strength, with a material saving in cost. In one case, with a poorly graded stone, it was found that if the stone be sifted into three sizes and recombined, 1 : 2½ : 6 concrete of the graded stone gave as much strength as 1 : 2 : 4 concrete of the ungraded material. The saving in cost of cement amounted to 80 cents per cubic yard, with an estimated

additional cost of mixing of about 20 cents. Such results are obtained only for material which is badly graded originally, and probably for average materials the saving in cost of cement would not be enough to pay for regrading. On any important work, however, it is worth while to examine carefully the materials with reference to their granulometric composition.

**95. Tests for Compressive Strength.**—The compressive strength of concrete has commonly been tested on 6-inch or 12-inch cubes, and much of the available data is based upon such tests. The desirability of eliminating the corners has led to the use of cylindrical specimens, which are found much easier to make and handle satisfactorily. The use of a test piece whose height is greater than its lateral diameter is also found advantageous. Blocks of concrete under crushing loads usually yield through shearing on surfaces making angles of about  $60^\circ$  with the horizontal, and by using blocks whose heights are twice the diameter sufficient freedom is allowed for such action. Tests have seemed to indicate that the strength of blocks varies somewhat with the ratio of height to diameter, cubes showing 25 to 35 per cent more strength per square inch than cylinders whose heights are twice their diameters. Blocks of greater relative height show a further loss of strength, but to much less degree, those having a height five times the diameter giving an average strength about 90 per cent of those with a ratio of 2 to 1.

A Committee of the American Concrete Institute recommended<sup>1</sup> that a cylindrical test piece be used, whose height is twice the diameter, and diameter at least four times the maximum size of the aggregate. Cylinders 8 inches in diameter and 16 inches high are used as standard by the Joint Committee on Concrete, though cylinders 6 inches by 12 inches are also sometimes used.

Forms made of cast iron, with a metal base, machined smooth and true, are made by manufacturers of testing apparatus; they are somewhat expensive, but are far more satisfactory in use than lighter forms. Forms made of sheet metal with flanges to bolt or clamp together may be used without the metal base by placing them on plate glass.

*Sampling the materials* should be carefully done to insure obtaining fair samples for the tests. To secure an average sample, the method of quartering is sometimes applied, which consists in taking shovelfuls of material from different parts of the pile, mixing them together and spreading out on the mixing surface. The resulting layer of material is then divided into quarters, two opposite quarters

<sup>1</sup> Journal, American Concrete Institute, Oct., 1914.



are shoveled away, the other two quarters are mixed again and the operation repeated until a sample of the size desired is obtained. When the materials are not uniform and vary in different parts of the supply, it may be desirable to take separate samples from each part and make comparative tests.

*Measurement of materials* should be by weight in making tests. When the proportions used in work are by volume the volume-weight of the materials should first be ascertained, and the weight proportions for the test pieces determined accordingly.

*Mixing* should be done on an impervious surface. The cement and sand should first be mixed thoroughly, to a uniform color, and spread evenly on the mixing surface. The coarse aggregate should then be spread over the dry mixture of sand and cement and the whole turned several times dry. Water may then be added in a crater and the mass turned and wet until it is thoroughly worked to uniform consistency.

On important work, it may often be desirable to test the concrete as it is being used, by making test pieces from the concrete as delivered for placing in the work.

*Forming the Block.*—The concrete should be tamped into the forms in layers so as to bring the mortar to the surfaces and leave no open spaces around the edges. After the concrete has set, the top of the block may be smoothed by leveling with cement paste or mortar, or with plaster of Paris, and a piece of glass pressed down on top and left until the mortar has set.

*Storage.*—In making tests for purposes of comparison, the test pieces should be kept moist while they are hardening. Blocks left in dry air do not gain strength normally.

*Testing.*—In making the tests, spherical bearing blocks should be used and care taken to permit the adjustment of the test pieces to uniform bearing, properly centered.

**96. Tensile and Transverse Strength.**—There are very few data available concerning the tensile strength of concrete, as it is not used where it is subject to direct tension, and this strength is of comparatively little interest. The tensile strength is called into play in unreinforced beams, but the action is quite different from that of a direct pull. The results of tests indicate that the tensile strength of concrete commonly varies from about one-fifteenth to one-twelfth of the compressive strength.

*The transverse strength* is dependent upon the tensile resistance of the material, and plain concrete is therefore a weak material for use in beams. On account of this weakness, concrete is seldom used

for beams without reinforcement, and in the computation of reinforced beams, the resistance of the concrete on the tension side of the beam is neglected.

The few data available indicate that the modulus of rupture for plain concrete beams varies from about one-eighth to one-fifth of the compressive unit strength, or that it is approximately twice the strength in direct tension. These values are based upon the application of the common theory of flexure, and the usual formulas for homogeneous materials. The difference between the modulus of rupture and tensile strength may be partly accounted for by the fact that the modulus of elasticity is not constant and the neutral axis does not remain at the gravity axis, but changes in position, approaching the compression side of the beam as the load increases, so that the actual tension does not reach the computed modulus of rupture.

#### ART. 26. COST OF CONCRETE WORK

**97. Cost of Materials.**—The cost of cement varies with the demand, and for different localities, with the cost of transportation. Prices for cement delivered should always be obtained in making estimates for work. The cost of wagon transportation in delivery of cement to the work varies with the condition of the roads and the means of transport available. A team may haul 10 or 12 barrels of cement on a fair country road, and travel about 20 miles per day; on hard-surface roads the loads may be increased, and auto transportation over good roads is less expensive.

The approximate quantities of materials required may be taken from the tables in Section 77. The following figures represent costs of work previous to the World War. The unsettled prices since existing make it impracticable to give later data of any value. These costs should probably be doubled at present (spring, 1920).

*Sand.*—For ordinary work in urban communities, sand may usually be purchased delivered, and estimates should be based upon the local prices, which vary in different localities (about \$.70 to \$1.60 is common) according to the nearness of the source of supply and the way in which the sand is delivered.

When sand is purchased by the ton, the weight per cubic yard must be ascertained to figure the cost accurately. Ordinary screened sand, with about 45 per cent voids, weighs from 2400 to 2500 pounds per cubic yard.

For sand taken from a pit, the costs include digging the sand, loading into wagons, and hauling to the work. In digging and load-

ing, 1 to  $1\frac{1}{2}$  hours labor is ordinarily required per cubic yard and at 20 cents per hour the cost may be from 25 to 35 cents per cubic yard. On well-organized work, where hauling is continuous, hauling may cost 7 to 10 cents per 1000 feet of distance, while on smaller and less well-arranged work, the cost may reach 12 to 15 cents, with team and driver at \$5 per day, but decreases as the length of haul increases. Hand screening usually costs somewhat less than loading, perhaps from 15 to 25 cents per cubic yard.

*Stone and Gravel.*—Broken stone or gravel, like sand, may usually be purchased for ordinary work by the cubic yard or by the ton. The weight per cubic yard depends upon the specific gravity of the stone and the percentage of voids. For ordinary crusher-run stone with the chips removed and about 45 per cent voids, granite or hard limestone weighs about 2500 pounds per cubic yard, trap about 2700 pounds; stone containing more fine material, in which the voids are 40 per cent, weighs about 10 per cent more than these figures.

When gravel is to be obtained from a pit, the cost of digging and loading, with labor at 20 cents an hour, commonly varies from about 35 to 50 cents per cubic yard, according to the quantity required and the arrangements for loading, while hauling is about the same as for sand. The cost of screening gravel by hand may vary from 30 to 55 cents per cubic yard, 45 cents being an ordinary average.

*Average Costs.*—Under average conditions, with a moderate haul the price of sand delivered on work varies from about 90 cents to \$1.20 per cubic yard; similarly screened gravel, \$1.20 to \$1.50, and broken stone, \$1.40 to \$1.75. When gravel or broken stone is delivered on cars, about 15 cents per cubic yard must be allowed for unloading.

**98. Cost of Labor.**—The labor required in concrete work includes handling the materials to the mixing platform, mixing the concrete and handling the concrete to place. The cost varies with the organization of the work and the experience of the men. The ability of the foreman to systematize and control the work is one of the most important items. The author on one occasion had two almost identical pieces of work in progress at the same time, and found after the first few days that one job was costing about 40 per cent more than the other, due almost entirely to differences in the management of the foremen.

When materials are conveniently arranged and the concrete, after mixing, may be shoveled into place from the mixing platform, the cost of mixing and placing concrete is commonly from \$0.90 to \$1.25 per cubic yard, with labor at 20 cents per hour. Wheeling



the concrete to place costs about 15 cents per cubic yard for the first 50 feet and 5 cents for each additional 50 feet. For work of moderate size the cost of machine mixing does not differ very materially from hand mixing, when the overhead charges are included.

In placing mass concrete in large work, the labor costs may be materially reduced where machinery is used for mixing and handling the concrete. Costs from 60 to 75 cents per cubic yard are not uncommon.

In reinforced concrete structural work, the placing of concrete is more expensive than ordinary work mentioned above, and the labor cost of mixing and placing concrete may be from \$1.50 to \$2 per cubic yard—figures which will vary with the difficulty of spading and compacting in the forms,<sup>4</sup> and with the means of distribution over the work.

In work for which considerable machinery is required, a charge for use of plant and supplies must be included, which will vary with the size of the job and the extent of the plant required. For building operations where a hoisting plant is necessary, it will be from 60 cents to \$1 per cubic yard.

**99. Total Costs.**—The costs for concrete in place include the costs for materials, labor, and plant. In the construction of a 1 : 3 : 6 concrete foundation for street pavement, an average cost is approximately as follows:

|  |        |
|--|--------|
| Cement, 1.02 barrel at \$1.75 . . . . .    | \$1.79 |
| Sand, 0.46 cubic yard at \$1.00 . . . . .  | 0.46   |
| Stone, 0.92 cubic yard at \$1.40 . . . . . | 1.29   |
| Labor, per cubic yard . . . . .            | 1.10   |

Total cost per cubic yard . . . . . \$4.64

For the construction of a concrete building, an average cost for 1 : 2 : 4 concrete of crusher run stone (45 per cent voids) may be as follows:

|  |        |
|--|--------|
| Cement, 1.47 barrel at \$1.80 . . . . .    | \$2.65 |
| Sand, 0.43 cubic yard at \$1 . . . . .     | 0.43   |
| Stone, 0.87 cubic yard at \$1.60 . . . . . | 1.39   |
| Labor per cubic yard . . . . .             | 1.50   |
| Plant per cubic yard . . . . .             | 0.80   |

Total cost per cubic yard . . . . . \$6.77

Allowance should be made for waste of materials, which always occurs to some extent—in some cases 5 per cent of the amount of

materials necessary to form the required concrete is needed to cover this loss. Care in handling the materials and close supervision of the mixing may reduce the loss to a negligible quantity, where the work is concentrated in large units.

The above figures do not include the cost of forms or of steel for reinforcement. Forms must be specially designed for each structure and the cost varies widely. In massive construction or in foundation work, the forms may be a comparatively small item, while for heavy walls requiring support on the sides, they may cost \$.50 per cubic yard or less. On structural work, including beams and columns, the cost of forms is frequently greater than that of the concrete. In such cases, only a careful design for the forms, and estimate of the materials and labor required for their erection, can give accurate data as to cost. In building work, the cost of forms is sometimes roughly estimated as about 8 to 10 cents per square foot of surface of concrete, where the use of the materials may be repeated, and when the forms can be used but once the cost is much greater.

Valuable information concerning the cost of concrete construction may be found in "Concrete Costs" by Taylor and Thompson, and in "Concrete Construction" by Gillette and Hill.

"Concrete, Plain and Reinforced," by Taylor and Thompson, gives a very complete discussion of the materials, proportions, methods of mixing and placing, and properties of plain concrete.

## CHAPTER VI

### REINFORCED CONCRETE

#### ART. 27. GENERAL PRINCIPLES

**100. Object of Reinforcement.**—Concrete and steel are frequently combined in structural work in two distinct types of construction:

1. *Structural Members of Steel Encased in Concrete.*—In this type of construction, the steel member is designed to carry the loads, and the concrete is used for protection of the steel against the weather or fire, or sometimes to give lateral stiffness to the member.

2. *Reinforced concrete*, in which the load-carrying member is made of concrete, the steel being used to strengthen the concrete by taking stresses that the concrete is unfitted to resist.

Structures of the first type, in which the concrete is used to give stiffness to the structure, are often classed as reinforced concrete, although reliance is placed upon the steel alone for carrying the loads. These are not, however, designed in accordance with the theories of reinforced concrete.

The advantages to be gained by combining steel and concrete are due to the fact that concrete is extremely weak and uneconomical when subjected to tension, but has much greater strength and is a convenient and economical material for resistance to compressions, while steel must be made of special forms satisfactorily to carry compression, but may be used for resisting tension in the form of ordinary bars.

In structural forms, such as beams, in which both tensile and compressive stresses are developed, the combination of the two materials offers an economical means of construction when the conditions are favorable, and the use of this type of construction has been rapidly extending during the past few years.

In the use of concrete and steel in combination, the following properties of the materials are important:

1. When steel bars are imbedded in concrete, the concrete adheres to the steel and develops a considerable bond strength, which may be relied upon to make the two materials act together.



2. Concrete acts as a protection to the steel against rust. In a number of instances in removing concrete structures, it has been found that the steel, after being embedded for several years, was in good condition and free from rust. To form an efficient protection the concrete must be mixed rather wet, so that the steel is completely covered with a coating of mortar.

3. The coefficients of expansion for the two materials are so nearly the same that no stresses need be considered as resulting from differences of expansions or contractions due to changes in temperature.

4. Changes in dimension occur in unreinforced concrete during hardening (see Section 85) and with variations in moisture conditions. When these changes are restrained by reinforcement, the concrete seems to adjust itself to the situation, adopting permanently the form in which it is held, without being placed under appreciable stress.

**101. Bond Strength.**—The stresses carried by the steel in a reinforced concrete structural member must usually be transmitted to the steel through the bond between the steel and concrete. Tests and experience show that plain steel bars imbedded in concrete develop considerable bond strength which may be relied upon to hold the bars permanently in place in resisting stresses which tend to separate them from the concrete. Experiments upon the adhesion of plain bars to concrete show that the bond strength is approximately proportional to the area of surface contact, and varies with the quality of the concrete, being nearly proportional to the strength in compression.

When tests are made by pulling a bar of steel out of a block of concrete in which its end has been embedded, the compression of the concrete may influence the results, and the bond strength shown be greater than would be developed in a beam where both steel and concrete are under tension. When the length of the bar embedded in the concrete is considerable, the bar may begin to slip at the surface of the block before the resistance of the more deeply embedded part is fully brought into play, and the bond resistance per unit of surface area be less than for shorter lengths. In tests at the University of Wisconsin no differences in unit bond strengths was found between 6-inch and 12-inch embedments.

Various tests have shown ultimate bond strengths for ordinary concrete from about 200 to 700 pounds per square inch of surface area of bar. In general, for concrete as commonly employed in

structural work the unit bond resistance for plain bars may be from 200 to 300 pounds per square inch.

Twisted and deformed bars are made in a number of forms for the purpose of increasing the bond strength, and are extensively used in reinforced concrete work; their raised projections or uneven surfaces give a mechanical bond and carry considerable more load before finally yielding than plain bars, although initial slip may occur under about the same stresses.

**102. Reinforcing Steel.**—The Joint Committee on Concrete makes the following recommendations<sup>1</sup> concerning steel for reinforcement bars:

The Committee recommends as a suitable material for reinforcement, steel of structural grade filling the requirements of the Specifications for Billet-Steel Concrete Reinforcement Bars of the American Society for Testing Materials.

For reinforcing slabs, small beams or minor details, or for reinforcing for shrinkage and temperature stresses, steel wire, expanded metal, or other reticulated steel may be used, with the unit stresses hereinafter recommended.

The reinforcement should be free from flaking rust, scale or coatings of any character which would tend to reduce or destroy the bond.

The Specifications of the American Society for Testing Materials are given in their Book of Standards or may be obtained in reprints from the Secretary of the Society.

On important work, it is common to purchase steel subject to these specifications, and to submit steel to careful inspection at the mills.

Engineers differ as to the advisability of using "hard-grade" steel for reinforcement. As a concrete beam usually gives way when the yield point of the steel is reached, through the cracking and crushing of the concrete, the yield point may be considered as the ultimate strength for concrete work, and some engineers prefer to use hard-grade steel on account of its high yield point. Medium steel is, however, usually preferred as less expensive and less likely to be brittle. When hard-grade steel is used, either high carbon or cold deformed material, it should be carefully tested, as it is more variable in quality than medium steel, but when meeting the specifications is a superior material.

For ordinary reinforced concrete work, mild steel as commonly found upon the market is usually employed. It is desirable to subject this to the cold bending test, which is the most important

<sup>1</sup> Proceedings, American Society of Civil Engineers, Dec. 1916.

test for reinforcing steel, and upon failure the material should always be rejected.

**103. Ratio of Moduli of Elasticity.**—The modulus of elasticity of a material is the ratio of unit stress to the corresponding unit deformation, within the elastic limit of the material.

When two materials with different moduli of elasticity, like steel and concrete, are combined in a structural member so that they must act together, as in a column, they will each be extended or compressed to the same amount, and the unit stress carried by each material will be proportional to the modulus of elasticity of the material.

When a beam is loaded so as to cause it to bend, it is lengthened on the convex and shortened on the concave side. Tests of reinforced concrete beams show that any plane section of the beam before bending remains approximately plane when bent, and that the amount of extension or shortening is proportional to the distance from its neutral surface. In such beams the stresses upon steel and concrete at the same distance from the neutral surface are proportional to the moduli of elasticity of the materials.

In the discussion of stresses in any structural member of steel and concrete subject to deformation, it is therefore necessary to know the ratio of the moduli of elasticity of the two materials in order to determine the amount of stress carried by each.

The modulus of elasticity of steel is practically the same for the different grades and is independent of the ultimate strength or yield point. An average value is about 30,000,000 lb./in., and this value is usually employed in reinforced concrete computations.

The modulus of elasticity of concrete is not a constant, but varies with the stress, becoming less as the stress becomes greater. For small stresses, within the limits of allowable working stress, however, the variation is very small, and the modulus of elasticity may be taken as constant without appreciable error. The formulas in common use are based upon the assumption of a constant modulus of elasticity, and variation of stress in beam design proportional to distance from the neutral axis.

Tests for the determination of the moduli of elasticity of concretes vary considerably in results, and indicate that the modulus depends upon the quality of the concrete, being approximately proportional to the compressive strength. The modulus also varies with the age of the concrete, increasing with age more rapidly than does the strength of the concrete.



The Joint Committee makes the following recommendation<sup>1</sup> concerning the modulus of elasticity:

The value of the modulus of elasticity of concrete has a wide range, depending on the materials used, the age, the range of stresses between which it is considered, as well as other conditions. It is recommended that in computations for the position of the neutral axis, and for the resisting moment of beams and for compression of concrete in columns, it be assumed as:

- (a) One-fortieth that of steel, when the strength of the concrete is taken as not more than 800 pounds per square inch.
- (b) One-fifteenth that of steel, when the strength of the concrete is taken as greater than 800 pounds per square inch and less than 2200 pounds per square inch.
- (c) One-twelfth that of steel, when the strength of the concrete is taken as greater than 2200 pounds per square inch and less than 2900 pounds per square inch and
- (d) One-tenth that of steel, when the strength of the concrete is taken as greater than 2900 pounds per square inch.

Although not rigorously accurate, these assumptions will give safe results. For the deflection of beams which are free to move longitudinally at the supports, in using formulas for deflection which do not take into account the tensile strength developed in the concrete, a modulus of one-eighth of that of steel is recommended.

**104. Reinforced Concrete in Tension.**—When reinforced concrete is subjected to tensile stresses, the two materials act together, each carrying unit stresses in proportion to its modulus of elasticity, so long as the stresses do not exceed the strength of the concrete. When, however, the steel is stressed to a fair working load, the stress upon the concrete will have passed its breaking strength, and it can no longer be considered as carrying stress—a condition which usually exists in reinforced concrete beams when carrying normal working loads. The steel in such beams is designed to carry all the tensions, the concrete on the tension side merely holding the steel in place.

In the earlier studies of reinforced beams, it was supposed that the concrete when reinforced became capable of carrying greater tensions than plain concrete, and beam formulas were proposed in which it was assumed that the concrete carried part of the tension. Later investigations, however, showed that this was erroneous and these formulas are no longer used in design.

Observations upon beams under tests have shown that minute cracks, invisible to the naked eye, frequently exist in the concrete

<sup>1</sup> Proceedings, American Society of Civil Engineers, Dec., 1916.

surface on the tension side while the beam is carrying only a safe load—a discovery made in testing damp beams with the tension side uppermost at the University of Wisconsin. Dark, wet lines appeared upon the surface at about the time that the ultimate strength of the concrete was reached, and these later developed into fine cracks. Experience with this type of construction indicates that, when the materials are properly used, no injury results from this overstressing of the concrete, and that the steel is fully protected by the concrete.

#### ART. 28. RECTANGULAR BEAMS WITH TENSION REINFORCEMENT

**105. Flexure Formulas.**—The common or straight-line formulas for reinforced concrete beams are based upon the ordinary theory of flexure, and involve the following assumptions:

- (1) A section of the beam that is plane before bending remains plane when bent.
- (2) The modulus of elasticity of concrete is constant within the limits of safe unit stresses.
- (3) The concrete resists compression only, all tensions being carried by the steel.
- (4) Initial stresses due to expansion or contraction of the concrete are negligible.

These assumptions greatly simplify the computations and are found experimentally to be sufficiently accurate within the limits of stresses used in ordinary beam design; they are not applicable to ultimate loads and can be used only for working loads and working stresses.

The following notation will be used:

- $h$  = total depth of beam;
- $b$  = breadth of beam;
- $d$  = depth of center of gravity of steel below compression face of beam, or effective depth of beam;
- $kd$  = depth of neutral axis below compression face of beam;
- $jd$  = distance between centers of tension and compression;
- $A$  = area of cross-section of steel;
- $p$  = ratio of steel area to effective area of beam ( $p = A/bd$ );
- $f_s$  = unit tensile stress on steel;
- $f_c$  = unit compressive stress on concrete at compression face;
- $E_s$  = modulus of elasticity of steel;
- $E_c$  = modulus of elasticity of concrete;

$n$  = ratio of moduli,  $E_s/E_c$ ;  
 $C$  = total compression in concrete;  
 $T$  = total tension in steel;  
 $M$  = resisting moment or bending moment.

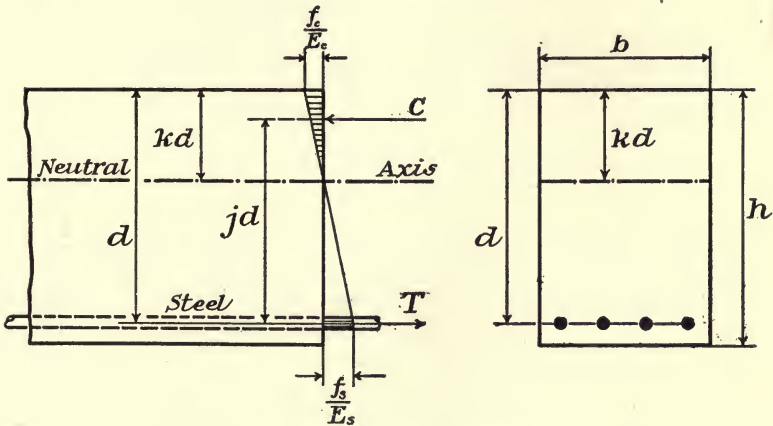

FIG. 45.—Reinforced Concrete Beam.

Assuming that a plane section before bending remains plane after bending, we have (see Fig. 45),

$$\frac{f_c/E_c}{f_s/E_s} = \frac{kd}{d - kd'}$$

OR

$$\frac{nf_c}{f_c} = \frac{k}{1 - k'}$$

from which we obtain

$$\frac{f_s}{f_c} = \frac{n(1 - k)}{k},$$

OR

$$k = \frac{nf_c}{f_s + nf_c} \dots \dots \dots (1)$$

The total compression on the concrete is,  $C = \frac{1}{2} f_c k b d$ .

The total tension on the steel is,  $T = A f_s = f_s p b d$ . These are equal for equilibrium; equating and reducing,

OR

$$f_s p = \frac{1}{2} f_c k,$$

$$\frac{f_s}{f_c} = \frac{k}{2p} \dots \dots \dots (2)$$



Combining (1) and (2) we have

$$p = \frac{k^2}{2n(1-k)} \dots \dots \dots (3)$$

and solving for  $k$ ,

$$k = \sqrt{2pn + (pn)^2} - pn. \dots \dots (4)$$

The centroid of compressive stresses is at a distance  $kd/3$  from the compressive face of the beam, and

$$jd = d - kd/3,$$

or

$$j = 1 - \frac{k}{3} \dots \dots \dots (5)$$

From the foregoing it is readily seen that the ratio of the unit stresses on the steel and concrete, and the values of  $k$ ,  $j$  and  $p$  are interdependent. If the unit stresses and value of  $n$  be assumed,  $k$  and the required percentage of steel may be found from Formulas (1) and (2). If the percentage of steel be known and the ratio  $n$  assumed, the values of  $k$  and the ratio  $f_s/f_c$  may be found from (4) and (2).

The resisting moment of the beam is due to the couple formed by the tensions and compressions and is equal to either of them into the arm of the couple:

$$M = Tjd = Af_sjd = f_s p j b d^2, \dots \dots \dots (6)$$

or

$$M = Cjd = \frac{1}{2} f_c k j b d^2, \dots \dots \dots (7)$$

and

$$bd^2 = \frac{M}{f_s p j} = \frac{2M}{f_c k j} \dots \dots \dots (8)$$

Formulas (6) and (7) give a means of determining the moment of resistance of a beam of known dimensions and safe unit stresses, while from (8) the necessary dimensions may be found to resist any given bending moment with assumed unit stresses in steel and concrete.

*Examples.*—The problems arising in the use of these formulas are of two kinds—the design of beams to carry certain loads; the investigation of existing beams to determine the loads they may safely carry, or the unit stresses resulting from given loads. The following examples illustrate the use of the formulas for these purposes:

1. A reinforced concrete beam is to carry a bending moment of 152,000 in.-lb. The safe unit stresses upon concrete and steel are

600 and 14,000 lb./in.<sup>2</sup> respectively.  $n=15$ . Find dimensions for the beam and area of steel required.

*Solution.*—Formula (1) gives

$$k = \frac{15 \times 600}{14000 + 15 \times 600} = .391,$$

from (5)

$$j = 1 - \frac{.391}{3} = .870 \quad \text{and} \quad (3) \quad p = \frac{(.391)^2}{2 \times 15(1 - .391)} = .0084$$

(8) now gives

$$bd^2 = \frac{152000}{14000 \times .0084 \times .87} = 1490.$$

We may now assume a value for either  $b$  or  $d$ , or fix a relation between them. Assuming  $b=8$  inches, we have  $8d^2=1490$  and  $d=13.7$  inches.  $A = pbd = .0084 \times 8 \times 13.7 = .92$  in.<sup>2</sup> Taking  $d$  as  $13\frac{3}{4}$  inches, if the concrete extends  $1\frac{3}{4}$  inches below the steel, the total depth,  $h = 13\frac{3}{4} + 1\frac{3}{4} = 15\frac{1}{2}$  inches.

2. A concrete beam is 9 inches wide and 16 inches deep, and is reinforced with four  $\frac{3}{4}$ -inch round steel bars, with centers 2 inches above the lower surface of the beam. The safe unit stresses for the concrete and steel are 700 and 14,000 lb./in.<sup>2</sup> respectively.  $n=15$ . What is the safe bending moment for the beam?

*Solution.*—The area of steel is  $A = .4418 \times 4 = 1.767$  in.<sup>2</sup>, and

$$p = \frac{A}{bd} = \frac{1.767}{9 \times 14} = .014.$$

Using (4),

$$k = \sqrt{2 \times 15 \times .014 + (15 \times .014)^2} - 15 \times .014 = .47.$$

$$(2) \text{ gives } \frac{f_s}{f_c} = \frac{.47}{2 \times .014} = 16.8.$$

This shows that if a stress of 14,000 lb/in.<sup>2</sup> be brought upon the steel, the stress upon the concrete will be greater than 700 lb./in.<sup>2</sup> Hence the safe moment is that which causes a stress of 700 lb./in.<sup>2</sup> in the concrete, or applying (7)

$$M = \frac{700}{2} (.47 \times .84 \times 9 \times \overline{14})^2 = 243750 \text{ in.-lb.}$$

3. If the beam in the preceding example is subjected to a bending moment of 225,000 in.-lb., what are the maximum stresses upon the steel and concrete?

*Solution.*—As in the preceding case, we find  $A = 1.767$  in.<sup>2</sup>,  $k = .47$ ,  $j = 0.84$  and  $f_s/f_c = 16.8$ .

From (6)

$$f_s = \frac{M}{Ajd} = \frac{225000}{1.767 \times .84 \times 14} = 10810.$$

$$f_c = 10810 / 16.8 = 644 \text{ lb./in.}^2$$

**106. Tables.**—The labor of computation in the use of the above formulas may be considerably lessened by tabulation of values of some of the terms involved.

In Formula (8), the denominators  $f_s pj$  and  $\frac{1}{2} f_c k j$  are constant for any particular values of  $f_s$  and  $f_c$ , and may be represented by a single term,

$$R = f_s pj = \frac{1}{2} f_c k j.$$

Substituting this in (8) we have

$$M = Rbd^2,$$

or

$$bd^2 = M/R. \quad \dots \dots \dots (9)$$

In Table VII values of  $j, k, p$  and  $R$  are given for several values of  $f_s$  and  $f_c$  when  $n = 15$ .

Table VIII gives values of the same quantities when  $n = 12$ .

In Table IX values of  $f_s/f_c, k, j$  and  $\frac{1}{2}jk$  are given for various values of  $p$ , with  $n = 12$  and  $n = 15$ .

Table X gives the areas and weights of square and round steel bars of the sizes commonly used in reinforced concrete work.

*Examples.*—The use of the tables will be illustrated by solving a few problems.

(4) A reinforced concrete beam is to resist a bending moment of 315,000 in.-lb. The safe unit stresses upon the concrete and steel are 650 and 16,000 lb./in.<sup>2</sup> respectively.  $n = 15$ . Find dimensions for the beam and area of steel required.

*Solution.*—From Table VII, for  $f_s = 16,000$  and  $f_c = 650$ , we find  $R = 108$  and  $p = .0078$ . Substituting this value of  $R$  in (9),  $bd^2 = M/R = 315000/108 = 2917$ . If we assume  $b = 10$  inches, we have  $d^2 = 2917/10 = 291.7$  and  $d = 17$  inches.

If the center of the steel be 2 inches from the surface of the concrete, the total depth of the beam,  $h = 17 + 2 = 19$  inches.

The area of steel required,  $A = pbd = .0078 \times 10 \times 17 = 1.33 \text{ in.}^2$

*Example 5.*—A concrete beam is 10 inches wide and 18 inches deep and is reinforced with four  $\frac{3}{4}$ -inch round steel bars, with centers 2 inches above the lower surface of beam. The safe unit stresses for



TABLE VII.—RECTANGULAR BEAMS

 $n = 15$ 

| $f_s$  | VALUES OF $f_c$ , LBS./IN. <sup>2</sup> |       |       |       |       |       |       |       |       |       |  |  |
|--------|---|-------|-------|-------|-------|-------|-------|-------|-------|-------|--|--|
|        | 500                                     | 550   | 600   | 650   | 700   | 750   | 800   | 850   | 900   |       |  |  |
| 14,000 | $k$                                     | .349  | .370  | .391  | .410  | .429  | .446  | .462  | .477  | .491  |  |  |
|        | $j$                                     | .884  | .877  | .870  | .863  | .857  | .851  | .846  | .841  | .836  |  |  |
|        | $p$                                     | .0062 | .0073 | .0084 | .0095 | .0107 | .0120 | .0133 | .0146 | .0158 |  |  |
|        | $R$                                     | 77.   | 89.   | 102.  | 115.  | 128.  | 143.  | 157.  | 171.  | 185.  |  |  |
| 15,000 | $k$                                     | .333  | .354  | .375  | .394  | .412  | .428  | .444  | .459  | .474  |  |  |
|        | $j$                                     | .889  | .882  | .875  | .869  | .863  | .857  | .852  | .847  | .842  |  |  |
|        | $p$                                     | .0055 | .0065 | .0075 | .0086 | .0097 | .0107 | .0118 | .0130 | .0142 |  |  |
|        | $R$                                     | 74.   | 86.   | 99.   | 112.  | 125.  | 138.  | 151.  | 166.  | 180.  |  |  |
| 16,000 | $k$                                     | .319  | .339  | .360  | .379  | .397  | .414  | .429  | .444  | .457  |  |  |
|        | $j$                                     | .894  | .887  | .880  | .874  | .868  | .862  | .857  | .852  | .848  |  |  |
|        | $p$                                     | .0050 | .0058 | .0068 | .0078 | .0087 | .0097 | .0107 | .0118 | .0128 |  |  |
|        | $R$                                     | 72.   | 83.   | 95.   | 108.  | 121.  | 134.  | 147.  | 161.  | 174.  |  |  |
| 18,000 | $k$                                     | .294  | .314  | .333  | .351  | .369  | .385  | .400  | .415  | .429  |  |  |
|        | $j$                                     | .902  | .895  | .889  | .883  | .877  | .872  | .867  | .862  | .857  |  |  |
|        | $p$                                     | .0041 | .0048 | .0055 | .0063 | .0072 | .0080 | .0089 | .0098 | .0107 |  |  |
|        | $R$                                     | 66.   | 77.   | 88.   | 100.  | 113.  | 126.  | 139.  | 152.  | 165.  |  |  |
| 20,000 | $k$                                     | .273  | .292  | .310  | .327  | .344  | .360  | .375  | .389  | .403  |  |  |
|        | $j$                                     | .909  | .903  | .897  | .891  | .885  | .880  | .875  | .870  | .866  |  |  |
|        | $p$                                     | .0034 | .0040 | .0046 | .0053 | .0060 | .0068 | .0075 | .0083 | .0091 |  |  |
|        | $R$                                     | 62.   | 72.   | 83.   | 94.   | 106.  | 119.  | 132.  | 145.  | 157.  |  |  |

concrete and steel are 700 and 16,000 lb./in.<sup>2</sup> respectively.  $n=15$ . What is the safe bending moment for the beam?

*Solution.*—From Table X, four  $\frac{3}{4}$ -inch round bars have area of 1.77 in.<sup>2</sup> and  $p=1.77/160=.0116$ . From Table IX, for  $p=.0116$  and  $n=15$ , we find  $f_s/f_c=19.2$  and  $jk/2=188$ .

TABLE VIII.—RECTANGULAR BEAMS WITH TENSION REINFORCEMENT

$n=12$

| $f_s$  |      | $f_c$ —LBS./IN. 2. |       |       |       |       |       |       |
|--------|------|--------------------|-------|-------|-------|-------|-------|-------|
|        |      | 700                | 750   | 800   | 850   | 900   | 950   | 1000  |
| 15,000 | $lc$ | .359               | .375  | .390  | .405  | .419  | .432  | .444  |
|        | $j$  | .880               | .875  | .870  | .865  | .860  | .856  | .852  |
|        | $p$  | .0084              | .0094 | .0104 | .0115 | .0125 | .0136 | .0147 |
|        | $R$  | 111.               | 123.  | 136.  | 149.  | 162.  | 175.  | 189.  |
| 16,000 | $k$  | .344               | .360  | .375  | .389  | .403  | .416  | .429  |
|        | $j$  | .885               | .880  | .875  | .870  | .866  | .861  | .857  |
|        | $p$  | .0075              | .0084 | .0094 | .0104 | .0114 | .0123 | .0134 |
|        | $R$  | 107.               | 119.  | 131.  | 144.  | 157.  | 170.  | 184.  |
| 18,000 | $k$  | .318               | .333  | .348  | .362  | .375  | .388  | .409  |
|        | $j$  | .894               | .889  | .884  | .879  | .875  | .871  | .867  |
|        | $p$  | .0062              | .0070 | .0078 | .0086 | .0094 | .0103 | .0111 |
|        | $R$  | 100.               | 111.  | 123.  | 135.  | 148.  | 161.  | 174.  |
| 20,000 | $k$  | .296               | .310  | .324  | .338  | .351  | .363  | .375  |
|        | $j$  | .901               | .897  | .892  | .887  | .883  | .879  | .875  |
|        | $p$  | .0052              | .0058 | .0065 | .0072 | .0079 | .0086 | .0094 |
|        | $R$  | 93.                | 104.  | 116.  | 128.  | 140.  | 152.  | 164.  |

When  $f_s=16,000$ ,  $f_c=16,000/19.2=833$  lb./in.<sup>2</sup> This is greater than the allowable stress on concrete, and the safe bending moment is that which causes a stress of 700 lb./in.<sup>2</sup> on the concrete, or by (7)  $700 \times .188 \times 10 \times 16 \times 16 = 336,900$  in.-lb.

*Example 6.*—A concrete beam 9 inches wide and 15 inches deep is reinforced with five  $\frac{1}{2}$ -inch round bars of steel, with centers 2 inches above lower face of beam. The beam carries a bending moment of 185,000 in.-lb. If  $n=12$ , find the unit stresses on the steel and concrete.

TABLE IX.—RECTANGULAR BEAMS WITH TENSION REINFORCEMENT

| <i>p</i> | <i>n</i> = 12 |          |              |   |                                 | <i>n</i> = 15 |          |              |   |                                 |
|----------|---------------|----------|--------------|---|---------------------------------|---------------|----------|--------------|---|---------------------------------|
|          | <i>k</i>      | <i>j</i> | <i>jk</i> /2 | <i>f<sub>s</sub></i> / <i>f<sub>c</sub></i> | <i>R</i> / <i>f<sub>s</sub></i> | <i>k</i>      | <i>j</i> | <i>jk</i> /2 | <i>f<sub>s</sub></i> / <i>f<sub>c</sub></i> | <i>R</i> / <i>f<sub>s</sub></i> |
| .0015    | .173          | .942     | .081         | 57.7  | .0014                           | .191          | .936     | .089         | 63.7  | .0014                           |
| .002     | .196          | .935     | .092         | 49.0  | .0019                           | .217          | .928     | .101         | 54.3  | .0019                           |
| .0025    | .217          | .928     | .100         | 43.4  | .0023                           | .239          | .920     | .110         | 47.8  | .0023                           |
| .003     | .235          | .922     | .108         | 39.3  | .0027                           | .258          | .914     | .118         | 43.0  | .0027                           |
| .0035    | .251          | .916     | .115         | 35.8  | .0032                           | .276          | .908     | .125         | 39.4  | .0032                           |
| .004     | .266          | .911     | .121         | 33.3  | .0037                           | .292          | .903     | .132         | 36.3  | .0036                           |
| .0045    | .279          | .907     | .126         | 31.0  | .0041                           | .307          | .898     | .137         | 33.9  | .0040                           |
| .005     | .291          | .903     | .131         | 29.1  | .0045                           | .320          | .893     | .142         | 31.6  | .0045                           |
| .0055    | .303          | .899     | .136         | 27.6  | .0049                           | .332          | .889     | .147         | 30.2  | .0049                           |
| .006     | .314          | .895     | .141         | 26.7  | .0054                           | .344          | .885     | .152         | 28.7  | .0053                           |
| .0065    | .325          | .892     | .145         | 24.9  | .0058                           | .355          | .882     | .156         | 27.5  | .0057                           |
| .007     | .334          | .889     | .149         | 23.9  | .0062                           | .365          | .878     | .160         | 26.1  | .0061                           |
| .0075    | .344          | .885     | .153         | 23.0  | .0066                           | .375          | .875     | .164         | 25.0  | .0066                           |
| .008     | .353          | .882     | .156         | 22.1  | .0071                           | .384          | .872     | .167         | 24.0  | .0070                           |
| .0085    | .361          | .879     | .159         | 21.3  | .0075                           | .393          | .869     | .171         | 23.1  | .0074                           |
| .009     | .369          | .877     | .162         | 20.5  | .0079                           | .402          | .866     | .174         | 22.3  | .0078                           |
| .0095    | .377          | .874     | .165         | 19.8  | .0083                           | .410          | .863     | .177         | 21.6  | .0082                           |
| .0100    | .384          | .872     | .167         | 19.2  | .0087                           | .418          | .861     | .180         | 21.0  | .0086                           |
| .011     | .398          | .867     | .175         | 18.1  | .0095                           | .433          | .856     | .185         | 19.7  | .0094                           |
| .012     | .412          | .863     | .178         | 17.2  | .0103                           | .446          | .851     | .190         | 18.6  | .0102                           |
| .013     | .425          | .859     | .182         | 16.4  | .0111                           | .458          | .847     | .194         | 17.7  | .0110                           |
| .014     | .436          | .855     | .186         | 15.6  | .0120                           | .470          | .843     | .198         | 16.9  | .0118                           |
| .015     | .447          | .851     | .190         | 14.9  | .0128                           | .482          | .839     | .202         | 16.1  | .0126                           |
| .016     | .457          | .848     | .194         | 14.3  | .0136                           | .493          | .836     | .206         | 15.4  | .0134                           |
| .017     | .467          | .845     | .197         | 13.7  | .0144                           | .503          | .832     | .210         | 14.8  | .0142                           |
| .018     | .476          | .842     | .200         | 13.2  | .0152                           | .513          | .829     | .213         | 14.3  | .0149                           |
| .019     | .485          | .839     | .203         | 12.8  | .0159                           | .522          | .826     | .216         | 13.8  | .0157                           |
| .020     | .493          | .836     | .206         | 12.4  | .0167                           | .531          | .823     | .219         | 13.3  | .0165                           |

From Table X, five  $\frac{1}{2}$ -inch round bars have an area of .98 in.<sup>2</sup>, and  $p = A/bd = .98/117 = .0084$ . From Table IX, for  $P = .0084$  and  $n = 12$ , we have  $jk/2 = .158$  and  $f_s/f_c = 21.5$ . By Formula (7),

$$f_c = \frac{M}{bd^2jk/2} = \frac{185000}{9 \times 13 \times 13 \times .158} = 770 \text{ lb./in.}^2$$

$$f_s = 21.5 f_c = 21.5 \times 770 = 16550 \text{ lb./in.}^2$$



TABLE X.—STEEL BARS. AREAS AND WEIGHTS

| Diam.<br>in<br>Inches. | Weight<br>per Ft.<br>Pounds. | Per-<br>meter<br>Inches. | AREAS OF DIFFERENT NUMBERS OF BARS—SQUARE INCHES. |      |      |      |       |       |       |       |       |  |
|------------------------|------------------------------|--------------------------|---|------|------|------|-------|-------|-------|-------|-------|--|
|                        |                              |                          | 1   | 2    | 3    | 4    | 5     | 6     | 7     | 8     | 9     |  |
| SQUARE BARS.           |                              |                          |   |      |      |      |       |       |       |       |       |  |
| 1/4                    | 0.212                        | 1.00                     | 0.0625  | 0.12 | 0.19 | 0.25 | 0.31  | 0.38  | 0.44  | 0.50  | 0.56  |  |
| 5/16                   | 0.333                        | 1.25                     | 0.0977  | 0.20 | 0.29 | 0.39 | 0.49  | 0.59  | 0.68  | 0.78  | 0.88  |  |
| 3/8                    | 0.478                        | 1.50                     | 0.1406  | 0.28 | 0.42 | 0.56 | 0.70  | 0.84  | 0.98  | 1.12  | 1.27  |  |
| 7/16                   | 0.671                        | 1.75                     | 0.1914  | 0.38 | 0.57 | 0.77 | 0.96  | 1.15  | 1.34  | 1.53  | 1.72  |  |
| 1/2                    | 0.850                        | 2.00                     | 0.2500  | 0.50 | 0.75 | 1.00 | 1.25  | 1.50  | 1.75  | 2.00  | 2.25  |  |
| 9/16                   | 1.076                        | 2.25                     | 0.3164  | 0.63 | 0.95 | 1.27 | 1.58  | 1.90  | 2.21  | 2.53  | 2.85  |  |
| 5/8                    | 1.328                        | 2.50                     | 0.3906  | 0.78 | 1.17 | 1.56 | 1.95  | 2.34  | 2.73  | 3.12  | 3.52  |  |
| 11/16                  | 1.608                        | 2.75                     | 0.4727  | 0.94 | 1.42 | 1.89 | 2.36  | 2.84  | 3.31  | 3.78  | 4.25  |  |
| 3/4                    | 1.913                        | 3.00                     | 0.5625  | 1.12 | 1.69 | 2.25 | 2.81  | 3.37  | 3.94  | 4.50  | 5.06  |  |
| 13/16                  | 2.245                        | 3.25                     | 0.6602  | 1.32 | 1.98 | 2.64 | 3.30  | 3.96  | 4.62  | 5.28  | 5.94  |  |
| 7/8                    | 2.603                        | 3.50                     | 0.7656  | 1.53 | 2.30 | 3.06 | 3.83  | 4.59  | 5.36  | 6.12  | 6.89  |  |
| 15/16                  | 2.988                        | 3.75                     | 0.8789  | 1.76 | 2.64 | 3.52 | 4.39  | 5.27  | 6.15  | 7.03  | 7.91  |  |
| 1                      | 3.400                        | 4.00                     | 1.0000  | 2.00 | 3.00 | 4.00 | 5.00  | 6.00  | 7.00  | 8.00  | 9.00  |  |
| 1/8                    | 4.303                        | 4.50                     | 1.2656  | 2.53 | 3.79 | 5.06 | 6.33  | 7.59  | 8.86  | 10.12 | 11.39 |  |
| 1/4                    | 5.312                        | 5.00                     | 1.5625  | 3.12 | 4.69 | 6.25 | 7.81  | 9.37  | 10.94 | 12.50 | 14.06 |  |
| 3/8                    | 6.428                        | 5.50                     | 1.8806  | 3.78 | 5.67 | 7.56 | 9.45  | 11.34 | 13.23 | 15.12 | 17.02 |  |
| 1/2                    | 7.650                        | 6.00                     | 2.2500  | 4.50 | 6.75 | 9.00 | 11.25 | 13.50 | 15.75 | 18.00 | 20.25 |  |
| ROUND BARS.            |                              |                          |   |      |      |      |       |       |       |       |       |  |
| 1/4                    | 0.167                        | 0.785                    | 0.0491  | 0.10 | 0.15 | 0.20 | 0.25  | 0.29  | 0.34  | 0.39  | 0.44  |  |
| 5/16                   | 0.261                        | 0.982                    | 0.0667  | 0.15 | 0.23 | 0.31 | 0.38  | 0.46  | 0.54  | 0.61  | 0.69  |  |
| 3/8                    | 0.375                        | 1.178                    | 0.1104  | 0.22 | 0.33 | 0.44 | 0.55  | 0.66  | 0.77  | 0.88  | 0.99  |  |
| 7/16                   | 0.511                        | 1.374                    | 0.1503  | 0.30 | 0.45 | 0.60 | 0.75  | 0.90  | 1.05  | 1.20  | 0.35  |  |
| 1/2                    | 0.667                        | 1.571                    | 0.1963  | 0.39 | 0.59 | 0.79 | 0.98  | 1.18  | 1.37  | 1.57  | 1.77  |  |
| 9/16                   | 0.845                        | 1.767                    | 0.2485  | 0.50 | 0.75 | 0.99 | 1.24  | 1.49  | 1.74  | 1.99  | 2.24  |  |
| 5/8                    | 1.043                        | 1.964                    | 0.3068  | 0.61 | 0.92 | 1.23 | 1.53  | 1.84  | 2.15  | 2.45  | 2.76  |  |
| 11/16                  | 1.262                        | 2.160                    | 0.3712  | 0.74 | 1.11 | 1.48 | 1.86  | 2.23  | 2.60  | 2.97  | 3.34  |  |
| 3/4                    | 1.502                        | 2.356                    | 0.4418  | 0.88 | 1.33 | 1.77 | 2.21  | 2.65  | 3.09  | 3.53  | 3.98  |  |
| 13/16                  | 1.763                        | 2.553                    | 0.5185  | 1.04 | 1.55 | 2.07 | 2.59  | 3.11  | 3.63  | 4.15  | 4.67  |  |
| 7/8                    | 2.044                        | 2.749                    | 0.6013  | 1.20 | 1.80 | 2.40 | 3.01  | 3.61  | 4.21  | 4.81  | 5.41  |  |
| 15/16                  | 2.347                        | 2.945                    | 0.6903  | 1.38 | 2.07 | 2.76 | 3.45  | 4.14  | 4.83  | 5.52  | 6.21  |  |
| 1                      | 2.570                        | 3.142                    | 0.7854  | 1.57 | 2.36 | 3.14 | 3.93  | 4.71  | 5.50  | 6.28  | 7.07  |  |
| 1/8                    | 3.379                        | 3.534                    | 0.9940  | 1.99 | 2.98 | 3.98 | 4.97  | 5.97  | 6.96  | 7.95  | 8.95  |  |
| 1/4                    | 4.173                        | 3.927                    | 1.2272  | 2.45 | 3.68 | 4.91 | 6.14  | 7.36  | 8.59  | 9.82  | 11.04 |  |
| 3/8                    | 5.049                        | 4.320                    | 1.4849  | 2.97 | 4.45 | 5.94 | 7.42  | 8.91  | 10.39 | 11.88 | 13.36 |  |
| 1/2                    | 6.008                        | 4.712                    | 1.7671  | 3.53 | 5.30 | 7.07 | 8.84  | 10.60 | 12.37 | 14.14 | 15.90 |  |

**107. Shearing Stresses.**—The distribution of shearing stresses in the section of a reinforced concrete beam differs from that in a homogeneous beam. The concrete between the neutral axis and the steel is not supposed to carry tension and consequently the unit shear is constant over this area. Fig. 46 represents a portion of a reinforced concrete beam, the length  $s$  being very short, so that the shear  $V$  may be the same upon its two ends. Let  $C_1$  and  $C_2$  represent the compression in the concrete on the two sides, and  $T_1$  and  $T_2$  the corresponding tensions in the steel. The difference of tensions  $T_1 - T_2$  must be communicated to the concrete and carried as horizontal shear to the compression side of the beam.

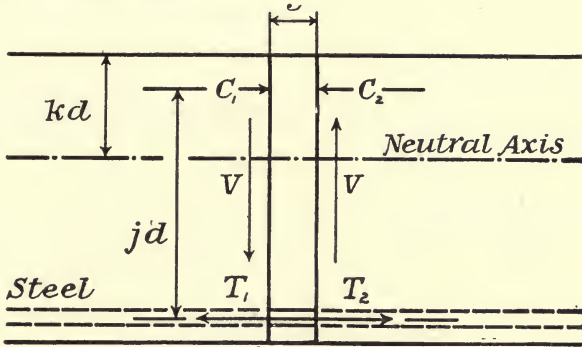

FIG. 46.

The intensity of the horizontal shear at any point is equal to the intensity of the vertical shear at the same point, as in any beam. If  $v$  is the shearing stress upon unit area and  $b$  the width of the beam, the total shear upon any horizontal section below the neutral axis is

$$vbs = T_1 - T_2.$$

For equilibrium of the forces acting upon the portion of the beam of length  $S$ , as shown in Fig. 4,  $T_1 - T_2 = C_1 - C_2$ , and the two couples are also equal, or  $Vs = (T_1 - T_2)jd$ . Equating these values of  $T_1 - T_2$ , and reducing, we find,

$$v = \frac{V}{bjd} \dots \dots \dots (10)$$

In designing reinforced concrete beams, it is usual to adopt a limiting value for  $v$  and make the section of the beam large enough so that the safe value of  $v$  as given by the above formula shall not be exceeded. The Joint Committee on Concrete recommends that the maximum value of  $v$  shall not exceed 6 per cent of the ultimate com-

pressive strength. This gives  $v=120$  lb./in.<sup>2</sup> as a safe value for ordinary concrete as commonly used in structural work (with crushing strength of about 2000 lb./in.<sup>2</sup> at thirty days).

Rectangular beams, reinforced for tension only, are usually sufficiently strong to resist direct shearing stresses when properly designed for flexural stresses. The areas of such beams are not affected by providing for shear, although they may sometimes need reinforcement against diagonal tension.

**108. Diagonal Tension.**—The intensity of the horizontal shear at any point in a beam is equal to the intensity of the vertical shear at the same point. In Fig. 47 let  $ABCD$  be an extremely small prism

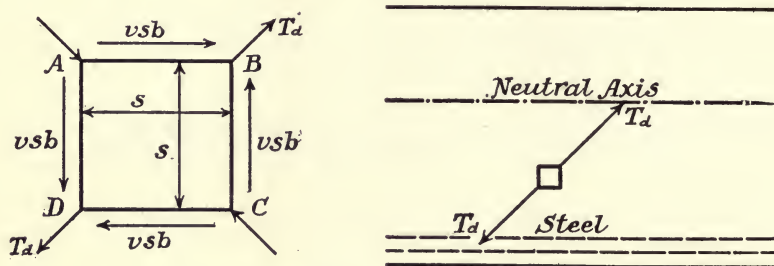

FIG. 47.—Diagonal Tension due to Shear.

in a reinforced beam, the vertical and horizontal dimensions of which, parallel to the side of the beam, are represented by  $s$ , and the thickness normal to the side by  $b$ . If  $v$  represent the unit shearing stress, the shear acting upon each of the four sides of the prism is  $vbs$ . If the two forces meeting at  $B$  and the two meeting at  $D$  be combined into resultants,  $T_d$ , there will result two equal and opposite forces producing tension in a diagonal direction upon the prism. The value of this tension is  $T_d = \frac{2vbs}{\sqrt{2}}$ , and it is distributed over an area,  $bs/\cos 45^\circ$ . The unit tension due to shear is

$$\frac{T_d}{bs\sqrt{2}} = \frac{2vbs}{\sqrt{2}} \times \frac{1}{bs\sqrt{2}} = v.$$

The unit diagonal tension due to shear is therefore equal to the unit shear and acts at an angle of  $45^\circ$  with the axis of the beam.

As is readily seen from Fig. 47, diagonal compression equal to the diagonal tension exists in a direction at right angles to the tension. The diagonal compression is unimportant and need not be considered in beam design, as these stresses are always small in comparison with



the compressive resistance of the concrete. It is, however, commonly necessary to reinforce concrete beams to prevent diagonal tension cracks, as failures of beams frequently occur from this cause.

In a homogeneous beam, the maximum tension at any point on the tension side of the neutral axis is the resultant obtained by combining the diagonal tension due to shear with the horizontal tension due to moment at the same point. In a reinforced concrete beam, the steel is supposed to carry all of the horizontal tension, and the concrete none. Some horizontal tension will necessarily be carried by the concrete, but, if sufficient horizontal reinforcement be used, the reinforcement for diagonal tension need provide only for tensions due to shear.

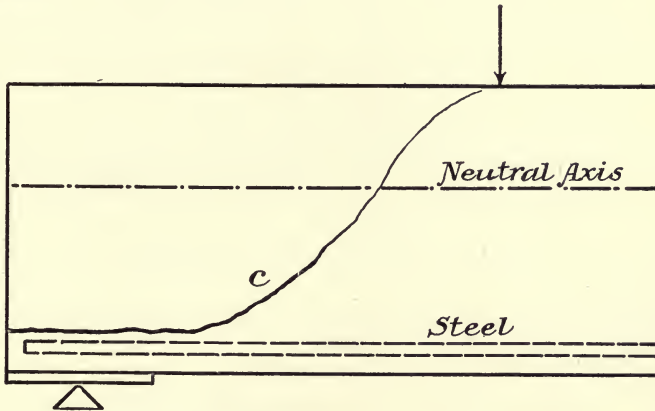

FIG. 48.—Diagonal Tension Failure.

Fig. 48 shows the form of failure likely to occur from diagonal tension, where horizontal reinforcement only is used. The diagonal tension at  $c$  becomes greater than the tensile strength of the concrete and the concrete cracks. A horizontal crack above the steel then follows, which separates the concrete from the steel and causes failure.

The safe resistance of concrete, without reinforcement, to diagonal tension is stated by the Joint Committee to be about one-third of the safe resistance to direct shear, or about 2 per cent of the ultimate compressive strength. For ordinary concrete, breaking at 2000 lb./in.<sup>2</sup> when twenty-eight days old, reinforcement against diagonal tension is necessary when  $v$  is greater than 40 lb./in.<sup>2</sup>.

Two methods of placing steel for diagonal tension reinforcement are commonly employed.

(a) Vertical stirrups may be used, designed to carry the vertical

component of the diagonal tension, leaving the horizontal component to be taken by the horizontal tension steel.

(b) The steel may be placed at an angle of  $45^\circ$  with the horizontal and parallel with the tensions due to shear. In this case the diagonal steel must be rigidly connected with the horizontal steel to prevent slipping horizontally, which is often accomplished by bending up part of the horizontal reinforcement near the end of the beam, where stresses due to moment are light.

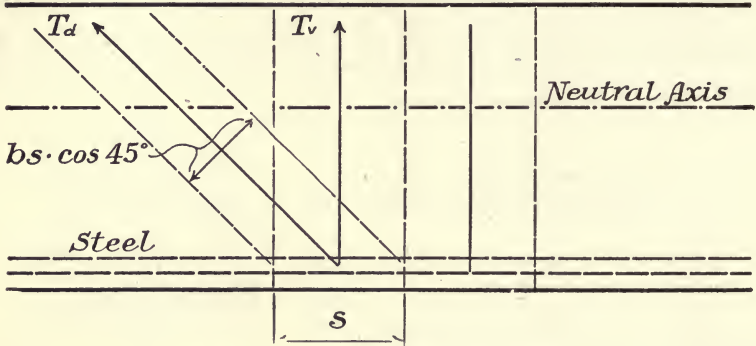

FIG. 49.—Vertical Stirrup Reinforcement.

*Vertical Stirrups.*—Fig. 49 shows a beam reinforced for diagonal tension by the use of vertical stirrups.

- Let  $s$  = length of beam to be reinforced by one stirrup;
- $V$  = Total vertical shear in section  $s$ ;
- $v$  = unit shearing stress;
- $T_a$  = Total diagonal tension in distance  $s$ ;
- $T_v$  = Total vertical tension in stirrup.

The average unit shear  $v = \frac{V}{bjd}$ . This is also the unit diagonal tension due to shear, acting at an angle of  $45^\circ$  with the horizontal, and the total tension is

$$T_a = vbs \cos 45^\circ = \frac{Vs \cos 45^\circ}{jd} \dots \dots \dots (11)$$

The vertical component of this carried by the stirrup is

$$T_v = vbs \cos^2 45^\circ = \frac{vbs}{2} = \frac{Vs}{2jd} \dots \dots \dots (12)$$

The total area of stirrup required to carry this stress is

$$A_v = \frac{vbs}{2f_s} = \frac{Vs}{2f_sjd} \quad \text{and} \quad s = \frac{2A_v f_s}{vb} = \frac{2A_v f_s jd}{V} \quad \dots \quad (13)$$

The Joint Committee recommends the use of the value

$$T_v = \frac{2}{3} \cdot \frac{Vs}{jd} \quad \text{or} \quad T_v = \frac{2}{3} \cdot vbs,$$

in place of that given in Formula (12).

In designing stirrup reinforcement, the spaces  $s$  may be assumed and the required area  $A_v$  of stirrups computed, or the spacing may be determined for stirrups of given area. The value of  $v$  to be used should be the average value for the space  $s$ .

In order to avoid danger of cracks between stirrups, the spaces  $s$  should not exceed one-half the effective depth of beam,  $\frac{1}{2}d$ . The shear is a maximum at the support, and the first space should be measured from the middle of the bearing on the support.

Diagonal tension reinforcement is needed only in the portion of the beam in which the shear exceeds the allowable unit shear for plain concrete (where  $v$  is greater than 2 per cent of the ultimate compressive strength of the concrete). In a uniformly loaded beam, the shear is zero at the middle of the beam and increases uniformly with the distance from the middle to a maximum at the support. If  $v_m$  is the maximum unit shear at the support and  $l$  the length of the beam the unit shear (or unit diagonal tension) at any point distant  $x$  from the middle of the beam is

$$v = \frac{2v_m x}{l}.$$

Reinforcement for diagonal shear is needed from the point where  $v$  equals the allowable shear for unreinforced concrete to the end of the beam. For ordinary concrete, in which the allowable unit shear is 40 lb./in.<sup>2</sup>, we have

$$x = \frac{40l}{2v_m}.$$

*Diagonal Reinforcement.*—Fig. 50 represents a beam reinforced for diagonal tension by bars inclined at 45° with the horizontal. As before, if the unit shear is more than 2 per cent of the ultimate compressive strength of the concrete, the beam needs reinforcement against diagonal tension.

Let  $s$  be the length of beam for which the steel at  $a$  is to carry the diagonal tension, and  $T_a$  the total tension in the steel at  $a$ .



$v = \frac{V}{bjd}$  is the unit diagonal tension on the concrete, and  $bs \cos 45^\circ$  is the section normal to the tension over which this unit diagonal tension is distributed. The total tension to be carried by the steel at  $a$  is

$$T_a = vbs \cos 45^\circ = \frac{V_s \cos 45^\circ}{jd} = \frac{V_s}{jd\sqrt{2}} \dots \dots (14)$$

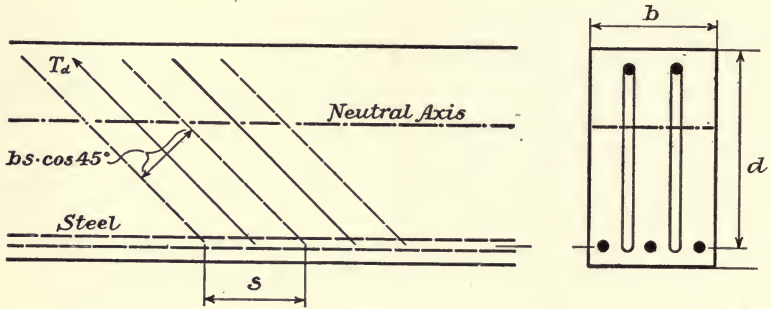

FIG. 50.—Diagonal Reinforcement.

The area of steel required is

$$A_a = \frac{vbs \cos 45^\circ}{f_s} = \frac{V_s}{f_s jd\sqrt{2}}$$

and

$$s = \frac{A_a f_s \sqrt{2}}{vb} \dots \dots \dots (15)$$

The limits within which reinforcement is necessary, and its proper spacing, may be determined in the same manner as for vertical stirrups. Where diagonal reinforcement is used, the spacing should not exceed three-fourths of the effective depth of beam or  $s = \frac{3}{4}d$ .

*Bending up Horizontal Steel.*—Diagonal reinforcement is commonly provided by bending up a portion of the horizontal steel near the supports where it is not needed for horizontal tension. In a simple beam uniformly loaded, the moment diagram is a parabola (see Fig. 51) and the diminution of the moment from the middle toward the ends is proportional to the square of the distance from the middle of the beam. Thus if  $M$  is the moment at the middle  $M_x$ , the moment at a point distant  $x$  from the middle, and  $l/2$ , the distance from the middle of the beam to the support.

$$\frac{M - M_x}{M} = \frac{x^2}{(l/2)^2}$$

or

$$M - M_x = \frac{Mx^2}{(l/2)^2} \dots \dots \dots (16)$$

The area of horizontal steel needed at any point varies directly with the moment at the point. If  $A$  is the area required at the middle and  $A_x$  the area needed at any point distant  $x$  from the middle,

$$A - A_x = \frac{Ax^2}{(l/2)^2}, \dots \dots \dots (17)$$

and

$$x = \frac{l}{2} \sqrt{\frac{A - A_x}{A}} \dots \dots \dots (18)$$

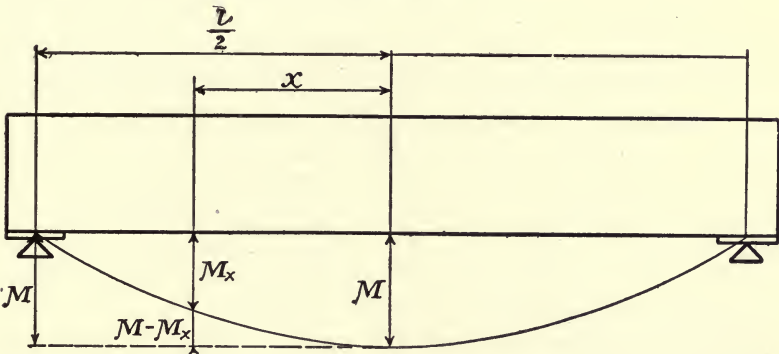

FIG. 51.—Distribution of Moment.

$A - A_x$  is the area of steel that it is allowable to turn up at distance  $x$  from the middle of the beam.

The Joint Committee does not consider diagonal tension reinforcement to be fully effective unless it is firmly attached to the longitudinal tension bars. When stirrups are looped about the longitudinal steel, the Committee recommends that the allowable unit shear ( $v = \frac{V}{bjd}$ ) be made  $4\frac{1}{2}$  per cent of the ultimate compressive strength, while when fully reinforced with bars firmly attached 6 per cent may be allowed.

**109. Bond Resistance and Lateral Spacing.**—The stress carried by the steel in a reinforced concrete beam is transmitted to the steel through the bond existing between the concrete and steel.

*Horizontal Tension Bars.*—The amount of stress that may be transmitted to the horizontal steel at any cross-section of the beam is equal to the horizontal shear at the section.

Let  $v = \frac{V}{bjd}$  = the unit horizontal shear in the concrete at any section;

$u$  = the unit bond stress between the steel and concrete;

$\Sigma o$  = total circumference of steel bars in the section;

$b$  = width of beam.

The total horizontal shear for unit length of beam,  $bv = \frac{V}{jd}$ ;

then

$$u = \frac{bv}{\Sigma o} = \frac{V}{\Sigma o jd} \quad \dots \dots \dots (19)$$

and

$$\Sigma o = \frac{bv}{u} = \frac{V}{ujd} \quad \dots \dots \dots (20)$$

If  $u$  does not exceed the safe unit bond stress between the steel and concrete at the section of maximum shear, the horizontal shear may be communicated to the steel without danger of the bars slipping. The Joint Committee recommend that the safe bond stress between concrete and plain reinforcing bars be limited to 4 per cent of the compressive strength of the concrete, and for good deformed bars not to exceed 5 per cent. For ordinary concrete (compression 2000 lb./in.<sup>2</sup>) this would give a value for plain bars,  $u = 80$  lb./in.<sup>2</sup>, and for the best deformed bars,  $u = 100$  lb./in.<sup>2</sup>

In selecting sizes of bars for horizontal tension steel, care should be taken that the bars are not too large to give sufficient surface area to provide properly for bond stress. Thus, suppose a beam, in which  $b = 6$  inches,  $d = 10$  inches, and  $j = 0.85$ , requires for tension steel,  $A = 0.60$  in.<sup>2</sup> If the maximum value of shear  $V = 3200$  lb. and allowable unit bond stress  $u = 80$  lb./in.<sup>2</sup>, the required surface area of steel per inch of length,

$$\Sigma o = \frac{V}{ujd} = \frac{3200}{80 \times .85 \times 10} = 4.7 \text{ in.}^2$$

Referring to Table X, we find:

- For two  $\frac{5}{8}$ -in. round bars,  $A = 0.61$  and  $\Sigma o = 2 \times 1.96 = 3.92$  in.<sup>2</sup>
- three  $\frac{1}{2}$ -in. round bars,  $A = 0.59$  and  $\Sigma o = 3 \times 1.57 = 4.71$  in.<sup>2</sup>
- four  $\frac{7}{16}$ -in. round bars,  $A = 0.60$  and  $\Sigma o = 4 \times 1.37 = 5.48$  in.<sup>2</sup>
- six  $\frac{5}{16}$ -in. square bars,  $A = 0.59$  and  $\Sigma o = 6 \times 1.25 = 7.50$  in.<sup>2</sup>

The  $\frac{5}{8}$ -inch bars are too large for the bond stress; the  $\frac{1}{2}$ -inch bars are just sufficient; the  $\frac{7}{16}$ -inch bars are still better and would probably be selected.



*Length of Bar to Prevent Slipping.*—The stress carried by any reinforcing bar must be transmitted to the concrete between the point at which the stress exists and the end of the bar, which must be accomplished either by having a sufficient length of bar to develop bond stress equal to the maximum tension or by anchoring the bar by other means.

- Let  $f_s$  = tensile stress per square inch in the bar;
- $i$  = diameter of bar in inches;
- $u$  = allowable bond stress per square inch;
- $l_b$  = length required for bond.

For round bar, the total stress =  $\frac{\pi i^2 f_s}{4} = \pi i l_b u$ .

For square bars, the total stress =  $i^2 f_s = 4 i l_b u$ .

Then for either round or square bars,

$$l_b = \frac{f_s i}{4u} \dots \dots \dots (21)$$

If  $f_s = 16,000$  lb./in.<sup>2</sup> and  $u = 80$  lb./in.<sup>2</sup>,  $l_b = 50i$ , or for safety, the length between the point where the stress of 16,000 lb./in.<sup>2</sup> exists and the end of the bar must be 50 diameters.

*Anchoring Bar by Bending.*—When it is not feasible to secure the length of bar necessary for bond, the end of the bar may be anchored in the concrete by bending to a semi-circle. Experiments indicate that, in general, the full strength of a bar in tension may be developed by bending the end to a semicircle, the diameter of which is four times the diameter of the bar. Short right-angled bends are found to be much less effective than curves through 180°.

In the case of restrained beams, or cantilevers, when maximum tension occurs near the support, careful attention must be given to the anchorage of the bars. Bars used for diagonal tension reinforcement, either vertical stirrups or inclined bars, have maximum tension at the neutral axis, and must have a sufficient embedment on the compression side of the neutral axis to resist the maximum tension in the steel.

*Lateral Spacing of Steel.*—The horizontal tension rods in a reinforced concrete beam must be so spaced as to leave a sufficient area of concrete between them to carry the shear communicated to the concrete by the portion of the bars below the minimum section of concrete. This would require that for circular bars the horizontal section between rods be capable of carrying a shearing stress equal to the

bond stress on the lower half of the bars. If  $s_c$  be the clear spacing between the bars and  $i$  the diameter of the bar, for the round bar

$$s_c v = \frac{\pi i u}{2} \quad \text{or} \quad s_c = \frac{\pi i u}{2v}.$$

For the values of unit stress recommended by the Joint Committee ( $v=6$  per cent and  $u=4$  per cent of the ultimate compressive strength),  $v = \frac{3}{2}u$ , and for round bars,  $s_c = \frac{i u}{2v} = 1.05i$ .

For square bars with sides vertical,  $s_c v = 3i u$ , or  $s_c = 2i$ , and for square bars with diagonals vertical,  $s_c = \frac{4}{3}i$ .

For deformed bars these values would be increased in the ratio of 5 to 4.

The Joint Committee recommends<sup>1</sup> that:

The lateral spacing of parallel bars should not be less than three diameters from center to center, nor should the distance from the side of the beam to the center of the nearest bar be less than two diameters. The clear spacing between two layers of bars should be not less than 1 inch. The use of more than two layers is not recommended, unless the layers are tied together by adequate metal connections, particularly at and near points where bars are bent up or bent down. Where more than one layer is used at least all bars above the lower layer should be bent up and anchored beyond the edge of the support.

**110. Design of Beams.**—The methods of applying formulas and tables in the design of rectangular beams is illustrated in the following examples:

(7) Design a rectangular beam to have a span of 25 feet and carry a uniform load of 600 pounds per linear foot, in addition to its own weight, using working stresses recommended by the Joint Committee for concrete of 2000 lb./in.<sup>2</sup> compressive strength.

*Solution.*—From Table VII, for  $n=15$ ,  $f_s=16,000$  and  $f_c=650$ , we find  $R=108$ ,  $p=.0078$ ,  $j=.874$ .

Assume weight of beam = 300 pounds per linear foot.

$$\text{Then } M = \frac{\omega l^2}{8} = \frac{(600+300)(25)^2 \times 12}{8} = 843750 \text{ in.-lb.}$$

$bd^2 = M/R = 843750/108 = 7812$ , and for  $b=12$ ,  $d=25.5$ , for  $b=14$ ,  $d=23.6$  Taking  $b=14$  and total depth,  $h=25.5$ , weight of beam =  $14 \times 25.5 \times 150/144 = 372$  pounds per linear foot. The assumed load is too small. Assume weight of beam = 400 pounds per linear foot.

$$M = \frac{(600+400)(25)^2 \times 12}{8} = 937500 \text{ in.-lb.}, \text{ and } bd^2 = \frac{937500}{108} = 8681.$$

<sup>1</sup> Proceedings, American Society of Civil Engineers, December, 1916.

For  $b=14$ ,  $d=\sqrt{\frac{8681}{14}}=24.9$ . Using  $b=14$  and  $d=25$ , make  $h=27$ .

Then weight of beam  $=\frac{27 \times 14 \times 150}{144}=394$  pounds per linear foot, which agrees with the assumption.

Horizontal steel,  $A = pbd = .0078 \times 14 \times 25 = 2.73 \text{ in.}^2$

From Table X, seven  $\frac{5}{8}$ -inch square bars give  $A = 2.73 \text{ in.}^2$

five  $\frac{3}{4}$ -inch square bars give  $A = 2.81 \text{ in.}^2$

six  $\frac{3}{4}$ -inch round bars give  $A = 2.65 \text{ in.}^2$

Seven  $\frac{5}{8}$ -inch square bars, spaced  $1\frac{7}{8}$  inch c. to c. or six  $\frac{3}{4}$ -inch round bars, spaced  $2\frac{1}{4}$  inches c. to c. might be placed in the width of 14 inches, meeting the requirement of spacing 3 diameters c. to c. We will use five  $\frac{3}{4}$ -inch square bars, spaced  $2\frac{1}{2}$  inches c. to c. and 2 inches from side of beam.

Maximum Shear,  $V = \frac{\omega}{2} = \frac{25 \times 1000}{2} = 12,500 \text{ lb.}$

$$v_m = \frac{V}{bjd} = \frac{12500}{14 \times .874 \times 25} = 40.6 \text{ lb./in.}^2$$

The section is sufficient for shear, and no diagonal tension reinforcement is necessary.

Bond Stress, Table X, for five  $\frac{3}{4}$ -inch bars,  $\Sigma o = 5 \times 3.00 = 15 \text{ in.}^2$  and (19)

$$u = \frac{bv}{\Sigma o} = \frac{14 \times 40.6}{15} = 37.9 \text{ lb./in.}^2,$$

which is less than the allowable stress.

8. A simple beam of 10-foot span to center of bearings, is to carry a load of 400 pounds per linear foot. Design the beam, assuming  $n=15$ ,  $f_s=15,000 \text{ lb./in.}^2$ ,  $f_c=750 \text{ lb./in.}^2$ , safe value of unit shear  $=120 \text{ lb./in.}^2$ , and for diagonal tension on concrete  $=40 \text{ lb./in.}^2$

Solution.—Assuming the weight of beam as 65 pounds per linear foot, the total load is  $(400+65)10=4650$  pounds.

$$M = \frac{1}{8}\omega l = \frac{4650 \times 10 \times 12}{8} = 69750 \text{ in.-lb.}$$

From Table VII, for  $f_s=15,000$ ,  $f_c=750$ , and  $n=15$ , we have

$$R = 138, j = 0.857, \text{ and } p = .0107.$$

then  $bd^2 = M/R = 69750/138 = 505$ . If we assume  $b=5$ , we find  $d=10$ , and  $A = pbd = .0107 \times 5 \times 10 = 0.535 \text{ in.}^2$

By Table X, five  $\frac{3}{8}$ -inch round bars  $=.55 \text{ in.}^2$

four  $\frac{3}{8}$ -inch square bars  $=.56 \text{ in.}^2$

three  $\frac{7}{16}$ -inch square bars  $=.57 \text{ in.}^2$



The four  $\frac{3}{8}$ -inch square bars will fit in the width of beam with proper spacing, but we will use three  $\frac{7}{16}$ -inch bars.

If the concrete extend  $1\frac{1}{2}$  inches below the center of the steel,  $h = d + 1\frac{1}{2} = 11\frac{1}{2}$  inches, and the weight of beam is  $5 \times 11.5 \times 150 / 144 = 60$  lb./ft.; this is a little less than our assumed weight.

*Maximum Shear,*

$$V = \omega/2 = 2325 \text{ lb.} \quad v_m = \frac{V}{bjd} = \frac{2325}{5 \times .875 \times 10} = 54 \text{ lb./in.}^2$$

This is less than 120 lb./in.<sup>2</sup>, and the dimensions of the beam are sufficient.

*Reinforcement for diagonal tension* is needed beyond the point where  $v = 40$  lb./in.<sup>2</sup>, or  $x = \frac{40l}{2v_m} = \frac{40 \times 10}{2 \times 54} = 3.7$  feet. Reinforcement is required to  $5 - 3.7 = 1.3$  foot = 15.6 inches from the support.

*Vertical Stirrups.*—If we assume  $s = \frac{1}{2}d = 5$  inches for the stirrup next the support, we have (13).

$$A_v = \frac{vbs}{2f_s} = \frac{54 \times 5 \times 5}{2 \times 15000} = 0.09 \text{ in.}^2$$

For U-shaped stirrup, the section of rod required will be one-half of this, or 0.045 in.<sup>2</sup> one-quarter in round bars are sufficient, and three stirrups may be used, spaced 3, 8, and 13 inches from the middle of support.

*Bond Stress.*—For the horizontal steel, Table X,  $\Sigma o = 3 \times 1.75 = 5.25$  in.<sup>2</sup>, and (19)  $u = bv / \Sigma o = 5 \times 54 / 5.25 = 51.4$  lb./in.<sup>2</sup>, which is less than the allowable bond stress, and no anchoring is necessary.

For the vertical stirrups (21)  $l_b = \frac{f_s i}{4u} = \frac{15000}{4 \times 80 \times 4} = 11.8$  inches, or the stirrups need 11.8 inches above the neutral axis for anchorage; they must therefore have hooked ends.

## ART. 29. T-BEAMS WITH TENSION REINFORCEMENT

**111. Flexure Formulas.**—In a rectangular reinforced concrete beam, in which the steel carries all the tension, the area of concrete below the neutral axis does not affect the resisting moment of the beam. The office of this concrete is to hold the steel in place and carry the shear, thus connecting the steel with the compression area of concrete.

In a T-beam, the flange carrying the compression is connected with a narrow web which holds the steel, as shown in Fig. 52. When the neutral axis is in the flange, such a beam may be computed by the

formulas and tables used for a rectangular beam, using the width of the flange,  $b$ , as the width of the beam.

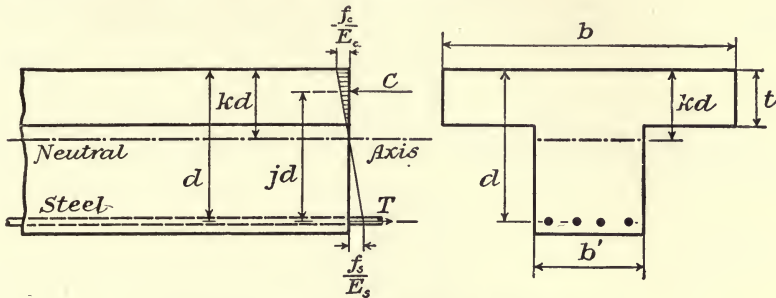

FIG. 52.—T-Beam with Tension Reinforcement.

When the neutral axis is below the bottom of the flange of the T-beam, the compression area is less than that of the rectangular beam, and special formulas are necessary. Fig. 52 represents a beam of this kind. The amount of compression on the web is usually very small and may be neglected without material error, thus greatly simplifying the formulas.

The same notation will be employed as in the rectangular beam, letting  $b$  = width of flange;

$b'$  = width of web;

$t$  = thickness of flange.

The position of the neutral axis in terms of the unit stresses may be found as in the rectangular beam, giving

$$\frac{f_s}{f_c} = \frac{n(l-k)}{k}, \dots \dots \dots (22)$$

and

$$k = \frac{nf_c}{f_s + nf_c}. \dots \dots \dots (23)$$

The average unit compression on the flange is the half sum of the compressions at the top and bottom of the flange, or

$$\frac{1}{2} \left( f_c + f_c \frac{kd-t}{kd} \right) = f_c \frac{2kd-t}{2kd}.$$

The total compression on the concrete is

$$C = f_c \frac{2kd-t}{2kd} bt. \dots \dots \dots (24)$$

This is the equal to the total tension on the steel,

$$T = f_s A = f_s pbd. \dots \dots \dots (25)$$

From the equality of (24) and (25) we find

$$p = \frac{(2k - t/d) \cdot t}{2n(l - k) \cdot d'} \quad \dots \dots \dots (26)$$

and

$$k = \frac{pn + \frac{1}{2}(t/d)^2}{pn + t/d} \quad \dots \dots \dots (27)$$

The distance of the centroid of compression from the upper face of the beam is

$$\frac{3k - 2t/d}{2k - t/d} \cdot \frac{t}{3}$$

therefore

$$jd = d - \frac{3k - 2t/d}{2k - t/d} \cdot \frac{t}{3} \quad \dots \dots \dots (28)$$

The resisting moment of the beam is

$$M = Tjd = A f_s jd = p f_s j b d^2 \quad \dots \dots \dots (29)$$

or

$$M = Cjd = f_c \frac{2k - t/d}{2k} \cdot b t j d \quad \dots \dots \dots (30)$$

*Examples.*—The use of these formulas in the solution of problems arising in the design or investigation of T-beams are illustrated in the following examples:

9. A T-beam has the following dimensions,  $b = 48$  inches,  $t = 4$  inches,  $d = 22$  inches,  $b' = 10$  inches. The steel reinforcement consists of six  $\frac{3}{4}$ -inch round rods. If the safe unit stresses of steel and concrete are 15,000 and 600 lb./in.<sup>2</sup> respectively, and  $n = 15$ , what is the safe resisting moment of the beam?

*Solution.*—From Table X,  $A = 2.65$  in.<sup>2</sup>, and  $p = \frac{2.65}{22 \times 48} = .0025$ ; formula (27) gives

$$k = \frac{.0025 \times 15 + \frac{1}{2} \left( \frac{4}{22} \right)^2}{.0025 \times 15 + \frac{4}{22}} = .247.$$

Using (28) we find

$$jd = 22 - \frac{3 \times .247 - 2 \left( \frac{4}{22} \right)}{2 \times .247 - \frac{4}{22}} \cdot \frac{4}{3} = 20.39.$$

From (22),

$$\frac{f_s}{f_c} = \frac{15(1 - .247)}{.247} = 45.7.$$

If  $f_c = 600$  lb./in.<sup>2</sup>,  $f_s = 600 \times 45.7 = 27,420$  lb./in.<sup>2</sup>

This is greater than the safe unit stress on steel, and the safe moment will be that which causes a stress of 15,000 lbs./in.<sup>2</sup> on the steel, or from (29),

$$M = 2.65 \times 15000 \times 20.39 = 810000 \text{ in.-lb.}$$



10. The flange of the T-beam is 26 inches wide and 4 inches thick. The beam is to carry a bending moment of 520,000 in.-lb. The safe unit stresses for concrete and steel are 600 and 16,000 lb./in.<sup>2</sup> respectively. What area of steel and depth of beam are needed.

*Solution.*—By (23)  $k = \frac{15 \times 600}{16000 \times 15 \times 600} = .360$ . We must now find  $d$  by assuming values and testing their suitability. Try  $d = 18$ ; from (28) we have

$$jd = 18 - \frac{3 \times .360 - 2\left(\frac{4}{18}\right)}{2 \times .360 - \frac{4}{18}} \cdot \frac{4}{3} = 16.3.$$

(9) gives  $C = M/jd = 520000/16.3 = 31900$ .

From (24)  $f_c = \frac{C}{\frac{2kd-t}{2kd}} \cdot bt = 440$  lb./in.<sup>2</sup> This is a safe value, but

a less depth will answer. Trying 15 inches, we find  $C = 38,000$  pounds, and  $f_c = 580$  lb./in.<sup>2</sup>; 15 inches is, therefore, approximately the minimum value for  $d$ . For this value of  $d$ , Formula (25) gives,

$$A = T/f_s = 38000/15000 = 2.375 \text{ in.}^2$$

*Width of Flange.*—T-beams without lateral reinforcement in the flanges should have a width of flange not more than three times the width of web,  $b = 3b'$ . When the flange is reinforced at right angles to the length of beam, as in a slab floor with T-beams support, experience indicates that the flange may overhang the web on each side to a distance equal to five or six times the thickness of flange, and still act satisfactorily as compression area for the beam. If the width of flange be greater than this, the extra width is of little value and should not be considered in estimating the strength of the beam.

The Joint Committee has recommended the following rules for determining flange width:

In beam and slab construction an effective bond should be provided at the junction of the beam and slab. When the principal slab reinforcement is parallel to the beam, transverse reinforcement should be used extending over the beam and well into the slab.

The slab may be considered an integral part of the beam, when adequate bond and shearing resistance between slab and web of beam is provided, but its effective width shall be determined by the following rules:

- (a) It shall not exceed one-fourth of the span length of the beam.
- (b) Its overhanging width on either side of the web shall not exceed six times the thickness of the slab.

In the design of continuous T-Beams, due consideration should be given the compressive stress at the support.

Beams in which the T-form is used only for the purpose of providing additional compression area of concrete should preferably have a width of flange not more than three times the width of the stem and a thickness of flange not less than one-third of the depth of the beam. Both in this form and in the beam and slab form the web stresses and the limitations in placing and spacing the longitudinal reinforcement will probably be controlling factors in design.

**112. Shear and Bond Stresses.**—Stresses due to shear in the concrete and bond stresses between the steel and concrete in T-beams are found by the same methods that are used for rectangular beams. The shearing and diagonal tension stresses must be carried by the web of the beam, the area of flange not being considered in finding unit shear. Using the same notation as for rectangular beams and letting  $b'$  represent the width of the web of the T-beam, the formulas as applied to T-beams become:

For shear, 
$$v = \frac{V}{b'jd'}$$

and 
$$b'd = \frac{V}{vj} \dots \dots \dots (33)$$

For vertical stirrups, 
$$A_v = \frac{vb's}{2f_s} = \frac{V_s}{2f_sjd'}$$

or 
$$s = \frac{2A_v f_s}{vb'} \dots \dots \dots (34)$$

For diagonal steel, 
$$A_d = \frac{vb's}{2f_s} = \frac{V_s}{2f_sjd'}$$

or 
$$s = \frac{2A_d f_s}{vb'} \dots \dots \dots (35)$$

For point where it is allowable to turn up steel, 
$$A - A_x = \frac{Ax^2}{(l/2)^2},$$

and 
$$x = \frac{l}{2} \cdot \frac{A - A_x}{A} \dots \dots \dots (36)$$

For bond stress, 
$$u = \frac{b'v}{\Sigma o} = \frac{V}{\Sigma ojd'}$$

and 
$$\Sigma o = \frac{b'v}{u} = \frac{V}{ujd'} \dots \dots \dots (37)$$

For length of bar to prevent slipping,

$$l_b = \frac{f_s l}{4u} \dots \dots \dots (38)$$

The Width of the Web ( $b'$ ) must be sufficient to provide proper area for carrying shear, as shown in (33), and also to allow for properly spacing the steel, as explained in Section 109.  $b'$  should not usually be taken at less than  $d/3$ , except in heavy beams where a thickness of  $d/4$  may be allowable. The value of  $j$ , when not known, may be assumed as  $\frac{7}{8}$  without material error, and the value of  $vj$  in (33) may be taken as  $\frac{7}{8}$  of the allowable unit shear.

**113. T-Beam Diagrams.**—The labor of T-beam computations may be considerably lessened by tabulation of some of the terms which enter into the formulas. Some of these tabulations are here given in the form of diagrams.

If we place  $Q = f_s j \cdot \frac{2k-t/d}{2k}$ ,  $Q$  will be constant for any particular values of unit stresses and  $t/d$ . Substituting in Formula (30) we obtain  $M = Qbtd$  and  $M/bt = Qd$  or

$$Q = M/btd. \dots \dots \dots (39)$$

In Diagram I, values of  $f_c$  and  $p$  are given in terms of various values of  $d/t$  and  $Q$  for  $n = 15$  and  $f_s = 16,000$ . This diagram may be used in design of beams when these units are to be employed, or similar diagrams may easily be prepared for other values of  $f_s$  and  $n$ .

Diagram II gives values of  $p$  and  $j$  in terms of  $f_s/f_c$  and  $d/t$ , when  $n = 15$ . This diagram may be used in reviewing a beam of known dimensions and reinforcement, or in design when values of  $f_s$  other than that used in Diagram I are to be employed.

*Examples.*—The following examples illustrate the use of these diagrams and formulas in computation.

11. A T-beam has dimensions as follows:  $b = 45$  inches,  $t = 4$  inches,  $d = 20$  inches,  $b' = 9$  inches. It is reinforced with ten  $\frac{3}{4}$ -inch round steel bars. If the safe unit stresses of steel and concrete are 16,000 and 650 lb./in.<sup>2</sup> respectively, what is the safe resisting moment for the beam?

*Solution.*—Table X,  $A = .4418 \times 10 = 4.418$  in.<sup>2</sup>, and  $p = \frac{4.418}{45 \times 20} = .0049$ . From Diagram II, for  $p = .0049$  and  $d/t = 5$ , we find  $f_s/f_c = 29$ , and  $j = .914$ . If  $f_c = 650$ ,  $f_s = 650 \times 29 = 18850$ . This is



more than is allowable, and the safe resisting moment is that giving a stress of 16,000 on the steel, or using (29)

$$M = A f_s j d = 4.418 \times 16000 \times .914 \times 20 = 1,292,800 \text{ in.-lb.}$$

12. The dimensions of a T-beam are,  $b = 36$  in.,  $t = 3$  in.,  $d = 13$  in., The beam is reinforced with six  $\frac{3}{4}$ -inch round steel bars. If this

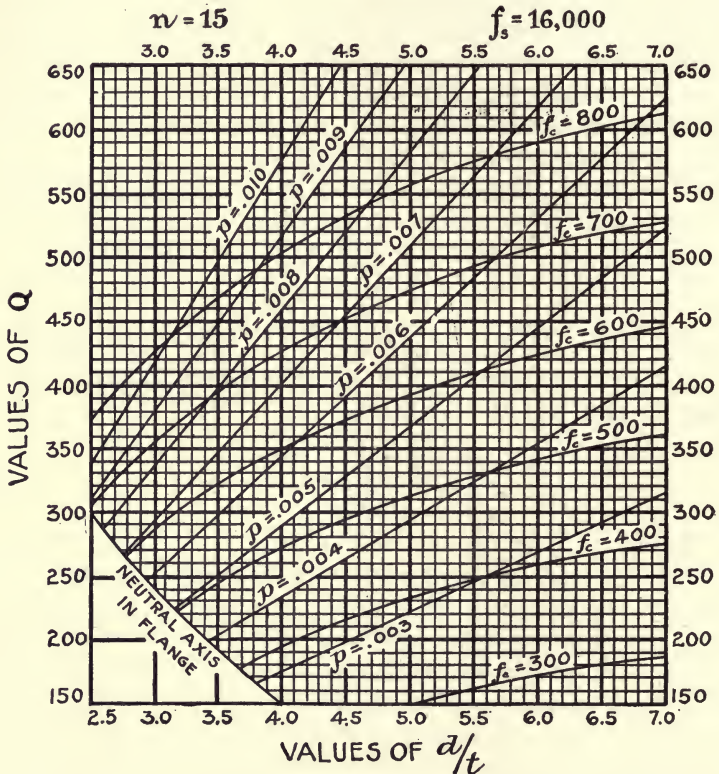

DIAGRAM I—for T-Beam Design.

$$M/bt = Qd.$$

beam is subjected to a bending moment of 550,000 in.-lb., what are the stresses in the steel and concrete respectively?

*Solution.*— $A = .4418 \times 6 = 2.65$  in.<sup>2</sup>, and  $p = \frac{2.65}{36 \times 13} = .0057$ .  
 $d/t = 13/3 = 4.33$ . From Diagram II, we find  $f_s/f_c = 27.5$  and  $j = .903$ .  
 Formula (29) now gives  $f_s = \frac{550000}{2.65 \times .903 \times 13} = 18270$  lb./in.<sup>2</sup>, from  
 which  $f_c = 18270/27.5 = 660$  lb./in.<sup>2</sup>

13. The flange of a T-beam is to be 30 inches wide and 5 inches thick. The beam is to sustain a bending moment of 930,000 in.-lb., and a maximum shear of 14,500 pounds. The safe unit stresses

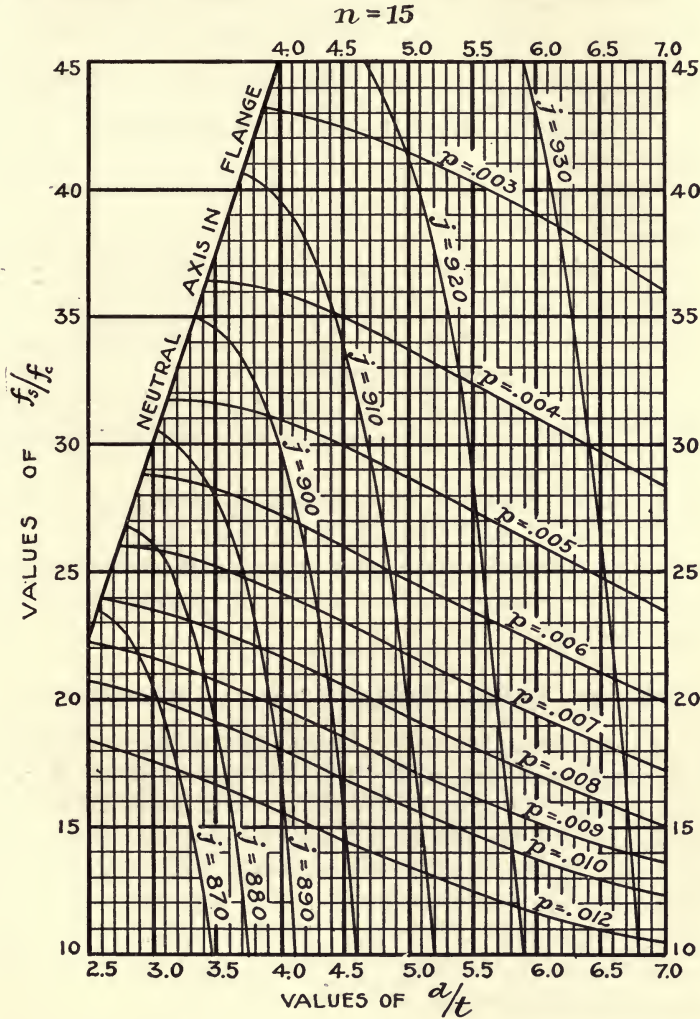

DIAGRAM II—for Review of T-Beam.

on steel and concrete are 16,000 and 650 lb./in.<sup>2</sup>, and maximum unit shear 120 lb./in.<sup>2</sup>. What dimensions of web and area of steel are required?

*Solution.*—Assuming  $j = \frac{7}{8}$ ,  $vj = 105$ , and from (33)  $b'd = \frac{V}{vj} = \frac{14500}{105}$

= 138 in.<sup>2</sup> For  $b'=8$ ,  $d=18$  or for  $b'=7$ ,  $d=20$  inches. Either of these values would give proper form to the web. The deeper beam will require less steel and may be used provided it gives sufficient width for placing the steel, and if the stress upon the concrete is satisfactory. Assume  $d=20$  inches. Then  $d/t=4$  and (31)

$$Q = \frac{930000}{30 \times 5 \times 20} = 310. \text{ For these values Diagram I gives } f_c = 540$$

lb./in.<sup>2</sup> and  $p = .0054$ .  $A = pbd = .0054 \times 20 \times 30 = 3.24$  in.<sup>2</sup> and (20)

$$\Sigma o = \frac{V}{ujd} = \frac{14500}{80 \times .9 \times 20} = 10.07 \text{ in.}$$

From Table X, for

six  $\frac{3}{4}$ -inch square bars,  $A = 3.37$  in.<sup>2</sup>,  $\Sigma o = 18.0$  in.

four  $\frac{5}{16}$ -inch square bars,  $A = 3.52$  in.<sup>2</sup>,  $\Sigma o = 15.0$  in.

four 1-inch round bars,  $A = 3.14$  in.<sup>2</sup>,  $\Sigma o = 12.56$  in.

The four  $\frac{5}{16}$ -inch bars could be placed in the 7-inch width of web in two rows (see Section 109). The six  $\frac{3}{4}$ -inch bars need a width of at least  $7\frac{1}{2}$  inches and could be used in two rows by increasing the width of web by  $\frac{1}{2}$  inch.

If  $d$  be made 21 inches, the steel needed would be  $A = 3.09$  in.<sup>2</sup> and the four 1-inch round bars could be used in two rows in the 7-inch width. At ordinary prices, the saving in steel would more than pay for the increased amount of concrete, and this would make the cheapest beam.

### ART. 30. BEAMS REINFORCED FOR COMPRESSION

**114. Flexure Formulas.**—It is frequently necessary to place steel in the compression as well as the tension side of a beam. When the size of a rectangular beam is limited, so that the concrete area is insufficient to carry the stress, steel may be used to take the surplus compression. In this case the concrete and steel act together, and the stress upon the steel must be limited to such an amount as will not overtax the compressive strength of the concrete.

In this discussion, the following notation will be used, in addition to that employed for rectangular beams:

$A'$  = area of cross-section of compression steel;

$p'$  = ratio of compression steel area to effective area of beam,  
( $p' = A'/bd$ );

$d'$  = depth of center of gravity of compression steel below  
compression face of beam;

$f'_s$  = unit stress in compression steel;

$C'$  = total compression on steel.



The same principles apply in this case as in that of the beam reinforced for tension only, and the concrete is supposed to carry compression but no tension. It is easily seen that

$$f_s = f_c \frac{n(l-k)}{k}, \dots \dots \dots (39)$$

and that

$$f'_s = n f_c \frac{kd-d'}{kd} = f_c \frac{n(k-d'/d)}{k} \dots \dots \dots (40)$$

Compression on concrete,

$$C = \frac{1}{2} f_c k b d, \dots \dots \dots (41)$$

and compression on steel,

$$C' = A' f'_s = f'_s p' b d. \dots \dots \dots (42)$$

Tension on steel,

$$T = C + C' = A f_s = f_s p b d. \dots \dots \dots (43)$$

Substituting (41) and (42) in (43) and combining with (39) and (40) we find

$$k = \sqrt{2n \left( p + p' \frac{d'}{d} \right) + n^2 \left( p + p' \frac{d'}{d} \right)^2} - n(p-p'). \dots \dots (44)$$

Taking moments about the tension steel, we find the resisting moment of the beam,

$$M = C j d + C' (d - d'). \dots \dots \dots (45)$$

*Example.*—The use of these formulas in design will be illustrated by the following example:

14. A beam whose dimensions are  $b = 12$  in.,  $d = 22$  in.,  $d' = 2$  in., is to carry a bending moment of 1,100,000 in.-lbs. The safe unit stresses are 700 and 16,000 lb./in.<sup>2</sup> for concrete and steel respectively,  $n = 15$ . Find the areas of steel required.

*Solution.*—For the given stresses (Table VII),  $k = .397$  and  $j = .868$ . Formula (41) gives

$$C = \frac{700}{2} \times .397 \times 12 \times 22 = 36680 \text{ pounds.}$$

From (45),

$$C' = \frac{1,100,000 - 36680 \times .868 \times 22}{20} = 19980.$$

By Formula (40),

$$f'_s = 15 \times 700 \times \frac{.397 - \frac{2}{22}}{.397} = 8085 \text{ lb./in.}^2$$

and (42)

$$A' = 19980/8085 = 2.47 \text{ in.}^2$$

Area of tension steel (43),

$$A = \frac{T}{f_s} = \frac{36680 + 19980}{16000} = 3.54 \text{ in.}^2$$

**115. Tables.**—The labor of computation may be materially lessened by the use of tables, which may be made in several ways, of which the following seem most convenient for use.

Table XI. Transposing the terms of formula (43) we have

$$A = \frac{C}{f_s} + \frac{C'}{f_s}$$

This may be placed in the form,

$$A = p_1bd + \frac{A'f'_s}{f_s}, \quad \dots \dots \dots (46)$$

in which  $p_1$  is the ratio of steel for a beam with the same unit stresses and without compression steel.

Formula (45) may be put in the form

$$M = Rbd^2 + f'_sA'(d - d')$$

or solving for  $A'$

$$A' = \frac{M - Rbd^2}{f'_s(d - d')}. \quad \dots \dots \dots (47)$$

Values of  $R$ ,  $p_1$  and  $f'_s$ , in terms of various values of  $f_s$ ,  $f_c$ , and  $d'/d$  for  $n = 15$ , are given in Table XI. This table may be used to find the areas of steel required when a beam of given dimensions must carry a bending moment too great to be resisted by tension reinforcement only.

Table XII. Combining (41), (42) and (45) we have

$$M = \frac{1}{2}f_cjkb d^2 + f'_sp'(l - d'/d)bd^2,$$

from which

$$M/bd^2 = \frac{1}{2}f_cjk + f'_sp'(l - d'/d) = G, \quad \dots \dots \dots (48)$$

in which  $G$  is constant for definite values of unit stresses and steel ratios. In Table XII, values of  $p'$  and  $p$  are given directly for various values of  $f_c$  and  $G$  when  $n = 15$  and  $f_s = 16,000 \text{ lbs./in.}^2$

To use this table in design, it is only necessary to find  $G$  by dividing the bending moment  $M$  by  $bd^2$  for the proposed beam and take the required ratios of steel directly from the table.

TABLE XI—BEAMS WITH COMPRESSION REINFORCEMENT.

Values of  $f's$  in terms of  $f_s, f_c$  and  $d'/d$

$$n = 15$$

| $f_s$  | $f_c$  | $R$ | $p_1$ | VALUES OF $d'/d$ . |       |       |      |      |      |      |      |
|--------|--------|-----|-------|--------------------|-------|-------|------|------|------|------|------|
|        |        |     |       | .06                | .08   | .10   | .12  | .14  | .16  | .18  | .20  |
| 14,000 | 500    | 77  | .0062 | 6210               | 5780  | 5350  | 4920 | 4490 | 4060 | 3630 | 3200 |
|        | 600    | 102 | .0084 | 7620               | 7160  | 6700  | 6240 | 5780 | 5320 | 4860 | 4400 |
|        | 700    | 128 | .0107 | 9030               | 8540  | 8050  | 7560 | 7070 | 6580 | 6090 | 5600 |
|        | 800    | 157 | .0133 | 10440              | 9920  | 9400  | 8880 | 8360 | 7840 | 7320 | 6800 |
| 15,000 | 500    | 74  | .0055 | 6150               | 5700  | 5250  | 4800 | 4350 | 3900 | 3450 | 3000 |
|        | 600    | 99  | .0075 | 7560               | 7080  | 6600  | 6120 | 5640 | 5160 | 4680 | 4200 |
|        | 700    | 125 | .0097 | 8970               | 8460  | 7950  | 7440 | 6930 | 6420 | 5910 | 5400 |
|        | 800    | 151 | .0118 | 10380              | 9840  | 9300  | 8760 | 8220 | 7680 | 7140 | 6600 |
| 16,000 | 500    | 72  | .0050 | 6090               | 5620  | 5150  | 4680 | 4210 | 3740 | 3270 | 2800 |
|        | 550    | 83  | .0059 | 6745               | 6310  | 5825  | 5340 | 4855 | 4370 | 3885 | 3400 |
|        | 600    | 95  | .0068 | 7500               | 7000  | 6500  | 6000 | 5500 | 5000 | 4500 | 4000 |
|        | 650    | 108 | .0078 | 8205               | 7690  | 7175  | 6660 | 6145 | 5630 | 5115 | 4600 |
|        | 700    | 121 | .0087 | 8910               | 8380  | 7850  | 7320 | 6790 | 6260 | 5730 | 5200 |
|        | 750    | 134 | .0097 | 9615               | 9070  | 8525  | 7980 | 7435 | 6890 | 6345 | 5800 |
|        | 800    | 147 | .0107 | 10320              | 9760  | 9200  | 8640 | 8080 | 7520 | 6960 | 6400 |
|        | 900    | 174 | .0128 | 11730              | 11140 | 10550 | 9960 | 9370 | 8780 | 8190 | 7600 |
|        | 18,000 | 600 | 88    | .0055              | 7380  | 6840  | 6300 | 5760 | 5220 | 4680 | 4140 |
| 700    |        | 113 | .0072 | 8790               | 8220  | 7650  | 7080 | 6510 | 5940 | 5370 | 4800 |
| 800    |        | 139 | .0089 | 10200              | 9600  | 9000  | 8400 | 7800 | 7200 | 6600 | 6000 |
| 900    |        | 165 | .0107 | 11610              | 10980 | 10350 | 9720 | 9090 | 8460 | 7830 | 7200 |
| 20,000 | 600    | 83  | .0046 | 7260               | 6680  | 6100  | 5520 | 4940 | 4360 | 3780 | 3200 |
|        | 700    | 106 | .0060 | 8670               | 8060  | 7450  | 6840 | 6230 | 5620 | 5010 | 4400 |
|        | 800    | 132 | .0075 | 10080              | 9440  | 8800  | 8160 | 7520 | 6880 | 6240 | 5600 |
|        | 900    | 157 | .0091 | 11490              | 10820 | 10150 | 9480 | 8810 | 8140 | 7470 | 6800 |

$$A' = \frac{M - Rbd^2}{f'_s(d-d')}, \quad A = p_1bd + \frac{A'f'_s}{f_s}$$



TABLE XII.—BEAMS WITH COMPRESSION STEEL

Values for  $p'$ .

$$f_s = 16,000. \quad n = 15. \quad G = M/bd.^2$$

| $f_c$ | $G$ | $p$   | VALUES OF $d'/d$ |       |       |       |       |       |       |       |       |
|-------|-----|-------|------------------|-------|-------|-------|-------|-------|-------|-------|-------|
|       |     |       | .06              | .08   | .10   | .12   | .14   | .16   | .18   | .20   |       |
| 500   | 72  | .0050 | .0000            | .0000 | .0000 | .0000 | .0000 | .0000 | .0000 | .0000 | .0000 |
|       | 80  | .0056 | .0014            | .0015 | .0017 | .0019 | .0022 | .0025 | .0030 | .0036 | .0042 |
|       | 100 | .0070 | .0049            | .0054 | .0060 | .0068 | .0077 | .0089 | .0104 | .0125 | .0152 |
|       | 120 | .0085 | .0084            | .0093 | .0103 | .0116 | .0132 | .0153 | .0189 | .0214 | .0254 |
|       | 140 | .0100 | .0119            | .0132 | .0146 | .0165 | .0188 | .0216 | .0264 | .0306 | .0366 |
|       | 160 | .0115 | .0154            | .0171 | .0190 | .0214 | .0243 | .0280 | .0338 | .0397 | .0477 |
|       | 180 | .0130 | .0189            | .0210 | .0233 | .0263 | .0298 |       |       |       |       |
| 600   | 95  | .0068 | .0000            | .0000 | .0000 | .0000 | .0000 | .0000 | .0000 | .0000 | .0000 |
|       | 100 | .0072 | .0007            | .0008 | .0009 | .0010 | .0011 | .0012 | .0014 | .0016 | .0018 |
|       | 120 | .0086 | .0035            | .0039 | .0043 | .0047 | .0053 | .0060 | .0068 | .0078 | .0090 |
|       | 140 | .0100 | .0064            | .0070 | .0077 | .0085 | .0093 | .0107 | .0122 | .0141 | .0166 |
|       | 160 | .0114 | .0091            | .0101 | .0111 | .0123 | .0136 | .0155 | .0176 | .0203 | .0238 |
|       | 180 | .0127 | .0120            | .0132 | .0145 | .0161 | .0178 | .0202 | .0230 | .0266 | .0314 |
|       | 200 | .0140 | .0148            | .0163 | .0179 | .0199 | .0220 | .0250 | .0284 | .0328 | .0388 |
| 650   | 108 | .0078 | .0000            | .0000 | .0000 | .0000 | .0000 | .0000 | .0000 | .0000 | .0000 |
|       | 120 | .0086 | .0015            | .0017 | .0019 | .0021 | .0023 | .0025 | .0028 | .0033 | .0039 |
|       | 140 | .0099 | .0041            | .0045 | .0050 | .0055 | .0061 | .0067 | .0076 | .0087 | .0100 |
|       | 160 | .0112 | .0067            | .0074 | .0081 | .0089 | .0099 | .0109 | .0124 | .0141 | .0166 |
|       | 180 | .0125 | .0093            | .0102 | .0112 | .0123 | .0137 | .0151 | .0172 | .0196 | .0234 |
|       | 200 | .0139 | .0119            | .0130 | .0143 | .0157 | .0174 | .0194 | .0219 | .0250 | .0296 |
|       | 220 | .0152 | .0145            | .0159 | .0174 | .0191 | .0212 | .0236 | .0267 | .0304 | .0358 |
| 700   | 121 | .0087 | .0000            | .0000 | .0000 | .0000 | .0000 | .0000 | .0000 | .0000 | .0000 |
|       | 140 | .0100 | .0023            | .0024 | .0026 | .0029 | .0032 | .0035 | .0040 | .0046 | .0054 |
|       | 160 | .0114 | .0046            | .0050 | .0054 | .0060 | .0066 | .0073 | .0082 | .0094 | .0109 |
|       | 180 | .0128 | .0070            | .0076 | .0083 | .0091 | .0100 | .0111 | .0125 | .0142 | .0164 |
|       | 200 | .0143 | .0094            | .0102 | .0111 | .0122 | .0135 | .0149 | .0167 | .0190 | .0220 |
|       | 220 | .0157 | .0118            | .0128 | .0140 | .0153 | .0169 | .0187 | .0210 | .0230 | .0266 |
|       | 240 | .0172 | .0142            | .0154 | .0168 | .0184 | .0203 | .0227 | .0252 | .0286 | .0334 |
| 750   | 126 | .0093 | .0000            | .0000 | .0000 | .0000 | .0000 | .0000 | .0000 | .0000 | .0000 |
|       | 140 | .0106 | .0023            | .0024 | .0026 | .0029 | .0032 | .0035 | .0040 | .0046 | .0054 |
|       | 160 | .0120 | .0046            | .0050 | .0054 | .0060 | .0066 | .0073 | .0082 | .0094 | .0109 |
|       | 180 | .0134 | .0070            | .0076 | .0083 | .0091 | .0100 | .0111 | .0125 | .0142 | .0164 |
|       | 200 | .0148 | .0094            | .0102 | .0111 | .0122 | .0135 | .0149 | .0167 | .0190 | .0220 |
|       | 220 | .0162 | .0118            | .0128 | .0140 | .0153 | .0169 | .0187 | .0210 | .0230 | .0266 |
|       | 240 | .0176 | .0142            | .0154 | .0168 | .0184 | .0203 | .0227 | .0252 | .0286 | .0334 |
| 800   | 131 | .0099 | .0000            | .0000 | .0000 | .0000 | .0000 | .0000 | .0000 | .0000 | .0000 |
|       | 140 | .0112 | .0023            | .0024 | .0026 | .0029 | .0032 | .0035 | .0040 | .0046 | .0054 |
|       | 160 | .0126 | .0046            | .0050 | .0054 | .0060 | .0066 | .0073 | .0082 | .0094 | .0109 |
|       | 180 | .0140 | .0070            | .0076 | .0083 | .0091 | .0100 | .0111 | .0125 | .0142 | .0164 |
|       | 200 | .0154 | .0094            | .0102 | .0111 | .0122 | .0135 | .0149 | .0167 | .0190 | .0220 |
|       | 220 | .0168 | .0118            | .0128 | .0140 | .0153 | .0169 | .0187 | .0210 | .0230 | .0266 |
|       | 240 | .0182 | .0142            | .0154 | .0168 | .0184 | .0203 | .0227 | .0252 | .0286 | .0334 |
| 850   | 136 | .0105 | .0000            | .0000 | .0000 | .0000 | .0000 | .0000 | .0000 | .0000 | .0000 |
|       | 140 | .0118 | .0023            | .0024 | .0026 | .0029 | .0032 | .0035 | .0040 | .0046 | .0054 |
|       | 160 | .0132 | .0046            | .0050 | .0054 | .0060 | .0066 | .0073 | .0082 | .0094 | .0109 |
|       | 180 | .0146 | .0070            | .0076 | .0083 | .0091 | .0100 | .0111 | .0125 | .0142 | .0164 |
|       | 200 | .0160 | .0094            | .0102 | .0111 | .0122 | .0135 | .0149 | .0167 | .0190 | .0220 |
|       | 220 | .0174 | .0118            | .0128 | .0140 | .0153 | .0169 | .0187 | .0210 | .0230 | .0266 |
|       | 240 | .0188 | .0142            | .0154 | .0168 | .0184 | .0203 | .0227 | .0252 | .0286 | .0334 |
| 900   | 141 | .0111 | .0000            | .0000 | .0000 | .0000 | .0000 | .0000 | .0000 | .0000 | .0000 |
|       | 140 | .0124 | .0023            | .0024 | .0026 | .0029 | .0032 | .0035 | .0040 | .0046 | .0054 |
|       | 160 | .0138 | .0046            | .0050 | .0054 | .0060 | .0066 | .0073 | .0082 | .0094 | .0109 |
|       | 180 | .0152 | .0070            | .0076 | .0083 | .0091 | .0100 | .0111 | .0125 | .0142 | .0164 |
|       | 200 | .0166 | .0094            | .0102 | .0111 | .0122 | .0135 | .0149 | .0167 | .0190 | .0220 |
|       | 220 | .0180 | .0118            | .0128 | .0140 | .0153 | .0169 | .0187 | .0210 | .0230 | .0266 |
|       | 240 | .0194 | .0142            | .0154 | .0168 | .0184 | .0203 | .0227 | .0252 | .0286 | .0334 |

TABLE XIII.—BEAMS WITH COMPRESSION STEEL

Values of  $f_s/f_c$  in Terms of  $p$  and  $p'$  $n = 15$ 

| $\frac{d'}{d}$ | $p'$ | VALUES OF $p$ |      |      |      |      |      |      |      |      |      |      |
|----------------|------|---------------|------|------|------|------|------|------|------|------|------|------|
|                |      | .008          | .009 | .010 | .011 | .012 | .014 | .016 | .018 | .020 | .022 | .024 |
| .06            | .004 | 28.1          | 26.0 | 24.3 | 22.8 | 21.3 | 19.3 | 17.7 | 16.3 | 15.1 | 14.1 | 13.1 |
|                | .006 | 30.1          | 27.8 | 26.0 | 24.3 | 22.9 | 20.5 | 18.8 | 17.3 | 16.1 | 15.0 | 14.0 |
|                | .008 | 32.1          | 29.7 | 27.6 | 25.9 | 24.4 | 21.7 | 19.8 | 18.3 | 17.0 | 15.8 | 14.9 |
|                | .010 | 34.2          | 31.6 | 29.4 | 27.4 | 25.7 | 23.2 | 21.1 | 19.5 | 17.9 | 16.7 | 15.7 |
|                | .012 | 36.3          | 33.4 | 31.0 | 29.1 | 27.3 | 24.5 | 22.2 | 20.4 | 18.9 | 17.6 | 16.5 |
|                | .014 | 38.4          | 35.3 | 32.6 | 30.6 | 28.7 | 25.8 | 23.4 | 21.6 | 19.8 | 18.4 | 17.3 |
|                | .016 | 40.5          | 37.2 | 34.3 | 32.2 | 30.2 | 27.0 | 24.6 | 22.8 | 20.7 | 19.3 | 18.2 |
|                | .018 | 42.3          | 39.0 | 36.1 | 33.8 | 31.7 | 28.3 | 25.9 | 23.8 | 21.7 | 20.1 | 18.9 |
|                | .020 | 44.1          | 40.8 | 37.9 | 35.3 | 33.2 | 29.6 | 27.2 | 24.8 | 22.7 | 21.0 | 19.7 |
|                | .10  | .004          | 27.5 | 25.6 | 23.9 | 22.4 | 21.1 | 19.1 | 17.5 | 16.1 | 15.0 | 14.0 |
| .006           |      | 29.2          | 27.2 | 25.3 | 23.7 | 22.4 | 20.2 | 18.5 | 17.0 | 15.8 | 14.8 | 13.8 |
| .008           |      | 30.8          | 28.7 | 26.7 | 24.9 | 23.7 | 21.3 | 19.4 | 18.0 | 16.7 | 15.5 | 14.6 |
| .010           |      | 32.6          | 30.1 | 28.1 | 26.3 | 25.0 | 22.4 | 20.4 | 18.9 | 17.6 | 16.4 | 15.4 |
| .012           |      | 34.3          | 31.5 | 29.5 | 27.7 | 26.2 | 23.5 | 21.5 | 19.7 | 18.4 | 17.2 | 16.1 |
| .014           |      | 36.0          | 33.1 | 30.9 | 29.0 | 27.4 | 24.6 | 22.5 | 20.6 | 19.2 | 18.0 | 16.9 |
| .016           |      | 37.6          | 34.6 | 32.3 | 30.2 | 28.6 | 25.8 | 23.5 | 21.5 | 20.0 | 18.7 | 17.6 |
| .018           |      | 38.1          | 36.1 | 33.7 | 31.6 | 29.8 | 26.9 | 24.4 | 22.4 | 20.8 | 19.5 | 18.3 |
| .020           |      | 40.6          | 37.7 | 35.1 | 32.9 | 30.9 | 27.9 | 25.4 | 23.4 | 21.6 | 20.2 | 18.9 |
| .14            |      | .004          | 26.9 | 25.1 | 23.4 | 22.0 | 20.8 | 18.8 | 17.3 | 16.0 | 14.8 | 13.8 |
|                | .006 | 28.4          | 26.4 | 24.6 | 23.2 | 21.9 | 19.8 | 18.2 | 16.8 | 15.5 | 14.5 | 13.6 |
|                | .008 | 29.8          | 27.6 | 25.8 | 24.3 | 23.0 | 20.8 | 19.0 | 17.5 | 16.3 | 15.2 | 14.3 |
|                | .010 | 31.2          | 28.9 | 27.0 | 25.4 | 24.1 | 21.8 | 19.9 | 18.3 | 17.1 | 16.0 | 15.0 |
|                | .012 | 32.5          | 30.2 | 28.2 | 26.5 | 25.1 | 22.7 | 20.7 | 19.1 | 17.8 | 16.7 | 15.7 |
|                | .014 | 33.7          | 31.4 | 29.4 | 27.6 | 26.1 | 23.6 | 21.6 | 19.9 | 18.5 | 17.4 | 16.3 |
|                | .016 | 34.9          | 32.5 | 30.5 | 28.7 | 27.1 | 24.5 | 22.4 | 20.6 | 19.2 | 18.0 | 16.9 |
|                | .018 | 36.1          | 33.7 | 31.6 | 29.8 | 28.1 | 25.4 | 23.2 | 21.3 | 19.9 | 18.7 | 17.5 |
|                | .020 | 37.1          | 34.9 | 32.6 | 30.8 | 29.0 | 26.2 | 24.0 | 22.0 | 20.6 | 19.3 | 18.1 |
|                | .18  | .004          | 26.1 | 24.6 | 23.1 | 21.7 | 20.5 | 18.6 | 17.1 | 15.7 | 14.6 | 13.6 |
| .006           |      | 26.9          | 25.6 | 24.1 | 22.7 | 21.4 | 19.4 | 17.8 | 16.4 | 15.3 | 14.3 | 13.4 |
| .008           |      | 28.6          | 26.6 | 25.0 | 23.6 | 22.3 | 20.2 | 18.5 | 17.1 | 15.9 | 14.9 | 14.0 |
| .010           |      | 29.6          | 27.6 | 25.9 | 24.5 | 23.2 | 21.0 | 18.3 | 17.8 | 16.5 | 15.5 | 14.6 |
| .012           |      | 30.6          | 28.6 | 26.8 | 25.3 | 24.0 | 21.8 | 20.0 | 18.5 | 17.2 | 16.1 | 15.2 |
| .014           |      | 31.6          | 29.6 | 27.7 | 26.1 | 24.8 | 22.6 | 20.7 | 19.2 | 17.9 | 16.7 | 15.8 |
| .016           |      | 32.6          | 30.5 | 28.6 | 27.0 | 25.6 | 23.3 | 21.4 | 19.8 | 18.5 | 17.3 | 16.3 |
| .018           |      | 33.6          | 31.4 | 29.4 | 27.8 | 26.4 | 24.1 | 22.1 | 20.4 | 19.1 | 17.9 | 16.9 |
| .020           |      | 34.5          | 32.2 | 30.3 | 28.6 | 27.2 | 24.8 | 22.8 | 21.0 | 19.7 | 18.4 | 17.4 |

TABLE XIV.—BEAMS WITH COMPRESSION STEEL

Values of  $N$  in Formula,  $Nf_c = M/bd$ ; $n = 15$ 

| $\frac{f_s}{f_c}$ | $\frac{d'}{d}$ | VALUES OF $p'$ |      |      |      |      |      |      |      |      |      |
|-------------------|----------------|----------------|------|------|------|------|------|------|------|------|------|
|                   |                | .002           | .004 | .006 | .008 | .010 | .012 | .014 | .016 | .018 | .020 |
| 16                | .06            | .228           | .252 | .277 | .302 | .327 | .351 | .376 | .401 | .425 | .450 |
|                   | .10            | .224           | .246 | .267 | .289 | .310 | .331 | .353 | .374 | .395 | .417 |
|                   | .14            | .221           | .240 | .258 | .276 | .295 | .313 | .331 | .349 | .368 | .386 |
|                   | .18            | .219           | .234 | .250 | .265 | .281 | .297 | .312 | .328 | .343 | .359 |
| 18                | .06            | .217           | .241 | .266 | .290 | .315 | .339 | .364 | .388 | .413 | .437 |
|                   | .10            | .213           | .234 | .255 | .276 | .297 | .318 | .339 | .360 | .381 | .402 |
|                   | .14            | .210           | .228 | .246 | .264 | .281 | .299 | .317 | .335 | .353 | .370 |
|                   | .18            | .207           | .222 | .237 | .252 | .266 | .281 | .296 | .311 | .326 | .340 |
| 20                | .06            | .208           | .232 | .256 | .281 | .305 | .329 | .354 | .378 | .402 | .426 |
|                   | .10            | .205           | .225 | .246 | .267 | .287 | .308 | .329 | .349 | .370 | .391 |
|                   | .14            | .201           | .219 | .236 | .253 | .271 | .288 | .306 | .323 | .340 | .357 |
|                   | .18            | .198           | .212 | .227 | .241 | .254 | .269 | .283 | .297 | .311 | .326 |
| 22                | .06            | .199           | .223 | .247 | .271 | .295 | .319 | .343 | .367 | .391 | .415 |
|                   | .10            | .195           | .216 | .236 | .256 | .277 | .297 | .317 | .337 | .358 | .378 |
|                   | .14            | .192           | .209 | .226 | .243 | .260 | .276 | .293 | .310 | .327 | .344 |
|                   | .18            | .187           | .202 | .216 | .229 | .243 | .257 | .270 | .284 | .297 | .311 |
| 24                | .06            | .191           | .215 | .239 | .263 | .286 | .310 | .334 | .353 | .381 | .405 |
|                   | .10            | .187           | .207 | .227 | .247 | .267 | .287 | .307 | .327 | .347 | .367 |
|                   | .14            | .184           | .200 | .217 | .233 | .249 | .266 | .282 | .299 | .315 | .332 |
|                   | .18            | .181           | .193 | .207 | .220 | .233 | .246 | .259 | .272 | .285 | .295 |
| 26                | .06            | .183           | .207 | .230 | .254 | .277 | .301 | .324 | .348 | .375 | .395 |
|                   | .10            | .179           | .199 | .218 | .238 | .257 | .277 | .296 | .316 | .335 | .355 |
|                   | .14            | .176           | .192 | .207 | .223 | .239 | .255 | .271 | .287 | .303 | .319 |
|                   | .18            | .172           | .185 | .197 | .209 | .222 | .234 | .246 | .259 | .271 | .284 |
| 28                | .06            | .177           | .201 | .224 | .247 | .271 | .294 | .317 | .340 | .364 | .387 |
|                   | .10            | .173           | .193 | .212 | .231 | .250 | .270 | .284 | .308 | .327 | .346 |
|                   | .14            | .170           | .185 | .201 | .216 | .231 | .247 | .263 | .278 | .293 | .309 |
|                   | .18            | .166           | .178 | .190 | .202 | .214 | .226 | .237 | .249 | .261 | .273 |
| 30                | .06            | .172           | .195 | .218 | .241 | .264 | .287 | .310 | .334 | .357 | .380 |
|                   | .10            | .168           | .187 | .205 | .224 | .243 | .262 | .281 | .300 | .319 | .338 |
|                   | .14            | .164           | .179 | .194 | .209 | .224 | .238 | .254 | .269 | .284 | .299 |
|                   | .18            | .160           | .171 | .183 | .194 | .205 | .217 | .228 | .239 | .251 | .262 |
| 32                | .06            | .166           | .188 | .211 | .233 | .256 | .278 | .301 | .323 | .346 | .368 |
|                   | .10            | .161           | .180 | .199 | .217 | .236 | .254 | .273 | .292 | .310 | .329 |
|                   | .14            | .157           | .172 | .186 | .201 | .215 | .230 | .244 | .259 | .273 | .289 |
|                   | .18            | .154           | .165 | .175 | .186 | .197 | .208 | .219 | .229 | .240 | .251 |



Tables XIII and XIV. If Formulas (39) and (44) be combined a value for  $f_s/f_c$  in terms of  $p$ ,  $p'$  and  $d'/d$  may be found. These values are tabulated in Table XIII.

If the values of  $f'_s$  from (40) be substituted in (48), it becomes

$$\frac{M}{bd^2} = \frac{1}{2}f_s j k + f_c n p' \left( \frac{k - d'/d}{d} \right) \left( l - \frac{d'}{d} \right),$$

and making

$$\frac{1}{2}j k + n p' \left( \frac{k - d'/d}{k} \right) (l - d'/d) = N,$$

we have

$$\frac{M}{bd^2} = N f_c. \quad \dots \dots \dots (49)$$

Combining the above value of  $N$  with (39) we find that the value of  $N$  depends upon  $n$ ,  $f_s/f_c$ ,  $p'$  and  $d'/d$ . In Table XIV, values of  $N$  are tabulated for various values of  $f_s/f_c$ ,  $p'$  and  $d'/d$  when  $n = 15$ .

These tables may be used in the investigation of beams of known dimensions and reinforcement, for the purpose of finding the safe resisting moment, or the unit stresses under given bending moment.

*Examples.*—The use of these tables will be best illustrated by a few examples.

15. Solve Problem 14 (p. 187) by the use of the tables.

*Solution.*—As  $n = 15$  and  $f_s = 16,000$  lb./in.<sup>2</sup>, Table XII may be used.  $d'/d = .09$ ,  $G = M/bd^2 = \frac{1100000}{12 \times 22 \times 22} = 190$ . From Table XII, with  $f_c = 700$ ,  $G = 190$  and  $d'/d = .09$ , we find directly that  $p = .0136$  and  $p' = .0093$ , from which,

$$A = .0136 \times 12 \times 22 = 3.59 \text{ in.}^2,$$

and

$$A' = .0093 \times 12 \times 22 = 2.46 \text{ in.}^2$$

16. A rectangular beam has the following dimensions;  $b = 10$  inches,  $d = 18$  inches,  $d' = 1.5$  inches, and is to carry a bending moment of 550,000 in.-lb. The safe unit stresses are 600 and 14,000 lb./in.<sup>2</sup> for concrete and steel respectively.  $n = 15$ . Find the areas of steel required.

*Solution.*— $d'/d = 1.5/18 = .083$ . From Table XI for  $f_s = 14,000$ ,  $f_c = 600$ , and  $d'/d = .083$ , we find  $R = 102$ ,  $p' = .0084$ ,  $f'_s = 7090$  lb./in.<sup>2</sup> substituting these values in (47) there results

$$A' = \frac{550000 - 102 \times 10 \times 18 \times 18}{7090 \times 16.5} = 1.88 \text{ in.}^2$$

and (46)

$$A = .0084 \times 10 \times 18 + \frac{7090}{14000} \times 1.88 = 2.46 \text{ in.}^2$$

17. A rectangular beam in which  $b=10$  inches,  $d=22$  inches and  $d'=2$  inches, is reinforced with 2.6 in.<sup>2</sup> of steel in tension and the same amount in compression. The beam carries a bending moment of 850,000 in./lb. What are the maximum unit stresses upon the steel and concrete respectively?

*Solution.*— $p=p'=\frac{2.6}{10 \times 22}=.0118$ .  $d'/d=.09$ . For these values Table XIII gives  $f_s/f_c=26.5$  and Table XIV,  $N=280$ . Then formula (49)

$$f_c = \frac{850000}{.280 \times 10 \times 22 \times 22} = 627 \text{ lb./in.}^2$$

$$f_s = 627 \times 26.5 = 16620 \text{ lb./in.}^2$$

18. A rectangular beam has  $b=10$  inches,  $d=16$  inches,  $d'=2$  inches,  $A'=2.4$  in.<sup>2</sup>,  $A=2.25$  in.<sup>2</sup>. If the safe unit stresses on steel and concrete are 16000 and 650 lb./in.<sup>2</sup> respectively, what is the safe resisting moment for the beam?

*Solution.*— $p'=\frac{2.4}{10 \times 16}=.015$ ,  $p=\frac{2.25}{10 \times 16}=.014$ ,  $d'/d=.125$ .

From Table XIII, for these values  $f_s/f_c=23.0$  and Table XIV,  $N=306$ . If  $f_s=16,000$ ,  $f_c=16,000/23=696$  lb./in.<sup>2</sup>, which is greater than is allowable. The safe moment will therefore be that which produces a stress of 650 lb./in.<sup>2</sup> in the concrete. Substituting in (49),

$$M = 306 \times 650 \times 10 \times 16 \times 16 = 509,184 \text{ in.-lb.}$$

### ART. 31. SLAB AND BEAM DESIGN

**116. Bending Moments and Shears.**—Structural forms in which slabs of concrete are supported by T-beams are very common in reinforced concrete structures. In this type of construction, the slab is commonly made continuous over the T-beam and forms the flange of the T-beam (see Fig. 53), being built with the beam and a part of it. In determining the bending moments and shears in such construction, the loads may usually be taken as uniform, and the slabs and beams as fully or partly continuous, depending upon the method of support.

*Fully Continuous Beams.*—If a slab which passes over one or more cross-beams is firmly held at the ends by being built into and tied by reinforcement to a wall or heavy beam, it may be considered as fully continuous, and when uniformly loaded, the positive moments of the middle of the spans are  $\frac{1}{4}wl^2$  and the negative moments at

supports  $\frac{1}{12}wl^2$ . The shear at each end of span in such a beam is  $\frac{1}{2}wl$ . If the movable load covers some of the spans leaving others unloaded, these moments may be somewhat increased. For slabs of this type, it is conservative practice to use  $\frac{1}{12}wl^2$  for both positive and negative bending moments and  $\frac{1}{2}wl$  for maximum vertical shear.

*Supported Ends.*—The ends of continuous beams, resting upon side walls or end columns, cannot be considered as fixed, and are to be taken as simply supported. Such a beam, or a slab the ends of which are not fixed, has greater positive moments in the end spans and greater negative moments at the first supports from the ends than fully continuous beams. These moments are usually taken as  $\frac{1}{10}wl^2$  for beams of more than two spans. The shear in the end span next the first support may be greater than one-half the load on the span and should be taken as  $.6wl$ . For beams of two spans, the negative moment at the middle support is taken as  $\frac{1}{8}wl^2$ , and the positive moment as  $\frac{1}{10}wl^2$ .

The moments for continuous beams of unequal spans, or with concentrated and uneven loading should be carefully determined for each individual case.

The Joint Committee makes the following recommendations in its 1916 report:

- (a) For floor slabs the bending moments at center and at support should be taken at  $\frac{wl^2}{12}$  for both dead and live loads, where  $w$  represents the load per linear unit and  $l$  the span length.
- (b) For beams the bending moment at center and at support for interior spans should be taken at  $\frac{wl^2}{12}$ , and for end spans it should be taken at  $\frac{wl^2}{10}$  for center and interior support, for both dead and live loads.
- (c) In the case of beams and slabs continuous for two spans only, with their ends restrained, the bending moment both at the central support and near the middle of the span should be taken at  $\frac{wl^2}{10}$ .
- (d) At the ends of continuous beams the amount of negative moment which will be developed in the beam will depend on the condition of restraint or fixedness, and this will depend on the form of construction used. In the ordinary cases a moment of  $\frac{wl^2}{16}$  may be taken; for small beams running into heavy columns this should be increased, but not to exceed  $\frac{wl^2}{12}$ .

For spans of unusual length, or for spans of materially unequal length, more exact calculations should be made. Special consideration is also required in the case of concentrated loads.



Even if the center of the span is designed for a greater bending moment than is called for by (a) or (b), the negative moment at the support should not be taken as less than the values there given.

**117. Loading of Slabs, Beams and Girders.**—Slabs are commonly used as continuous beams passing over a number of T-beams, of which the slab forms the flange as shown in Fig. 53.

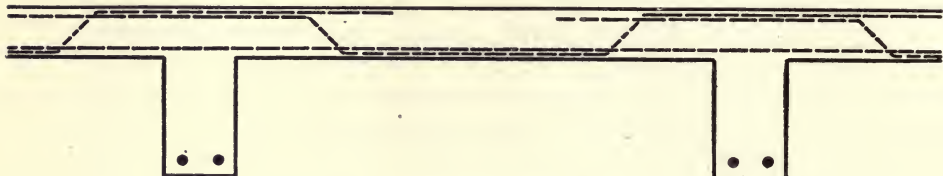

FIG. 53.—Reinforced Slab and T-Beam.

They are reinforced for tension in one direction, perpendicular to the T-beams, and in computation are considered as rectangular beams one foot in width. The T-beams supporting such slabs frequently rest upon girders, which are used to widen the interval between columns, and permit the T-beams to be spaced close enough for economical design of slab. The load upon a T-beam in such a system is uniformly distributed and consists of the weight of a half span of the slab and its load, on each side of the beam. The loads upon the girders are concentrated at the points where the T-beams cross, but may usually be taken as uniformly distributed without material error.

*Double Reinforced Slabs.*—Slabs of long span and nearly square in plan may be supported on all four sides and reinforced in both directions. It is not feasible to make an accurate analysis of the distribution of loadings in such a slab. When the length and width of slab are equal, it is assumed that the reinforcement in each direction carries one-half the load as uniformly distributed. The loads carried by the mid sections (*aaaa*, *bbbb*, Fig. 54) are, however, greater than those carried by the sections next the supports, and the reinforcement should be spaced closer in the middle than at the sides. It is suggested that the mid-half area (*aaaa*, *bbbb*, Fig. 80) of the slab be considered as carrying  $1\frac{1}{3}$  times the average load, and the side sections (*acca*, *bccb*) two-thirds of the average load per square foot of slab.

When the slabs are not square, the reinforcement parallel to its shorter dimension carries the greater part of the load. The Joint Committee makes the following recommendation concerning the division of the loads in such slabs:

Floor slabs having the supports extending along the four sides should be designed and reinforced as continuous over the supports. If the length of the

slab exceeds 1.5 times its width the entire load should be carried by transverse reinforcement.

For uniformly distributed loads on square slabs, one-half the live and dead load may be used in the calculations of moment to be resisted in each direction. For oblong slabs, the length of which is not greater than one and one-half times their width, the moment to be resisted by the transverse reinforcement may be found by using a proportion of the live and dead load equal to that given by the formula  $r = \frac{l}{b} - 0.5$ , where  $l$  = length and  $b$  = breadth of slab. The longitudinal reinforcement should then be proportioned to carry the remainder of the load.

In placing reinforcement in such slabs account may well be taken of the fact that the bending moment is greater near the center of the slab than near the

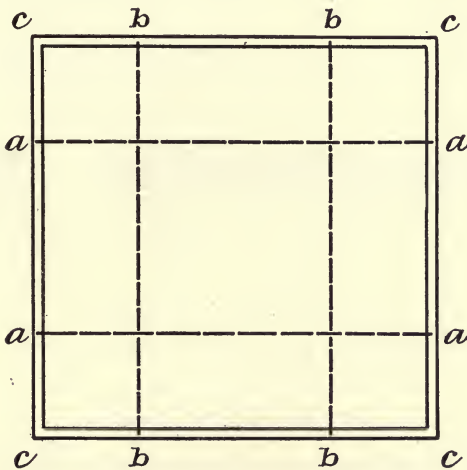

FIG. 54.—Double-reinforced Slabs.

edges. For this purpose two-thirds of the previously calculated moments may be assumed as carried by the center half of the slab and one-third by the outside quarters.

An interesting discussion of the distribution of stresses in double reinforced slabs may be found in a paper by Mr. A. C. Janni in Transactions of the American Society of Civil Engineers, 1917.

**118. Problems in Design.**—The use of the formulas and tables which have been given, in designing slab and beams, will be illustrated by the solution of a few problems. In these examples, the working stresses recommended by the Joint Committee for 2000 pounds concrete will be used.

*Example 19.*—A concrete slab is to be supported by T-beams 6 feet apart c. to c., and to carry a live load of 250 pounds per square

foot. The T-beams have a clear span of  $17\frac{1}{2}$  feet and are built into brick walls at the ends. Design the slab and beams.

*Solution.*—Assume the weight of slab as 50 pounds per square foot, giving a total load of 300 pounds per linear foot for a section of slab 12 inches wide. Taking the slab as fully continuous.

$$M = \frac{wl^2}{12} = \frac{300 \times 6 \times 6 \times 12}{12} = 10,800 \text{ in.-lb.}$$

From Table VII, for  $f_s = 16,000$  and  $f_c = 650$ ,  $R = 108$ ,  $p = .0078$  and  $j = .874$ . Formula (9) gives  $12d^2 = 10,800/108 = 100$ , and  $d = 2.9$  inches, use 3 inches.  $A = pd = 3 \times 12 \times .0078 = .277 \text{ in.}^2$  From Table XV (p. 199), we select  $\frac{3}{8}$ -inch round bars spaced 4.5 inches apart,  $A = .29 \text{ in.}^2$

If concrete extends  $\frac{3}{4}$  inch below steel, the thickness of slab is  $3\frac{3}{4}$  inches, and the weight of slab is  $150 \times 3.75/12 = 47$  pounds per square foot, which agrees with the assumed load.

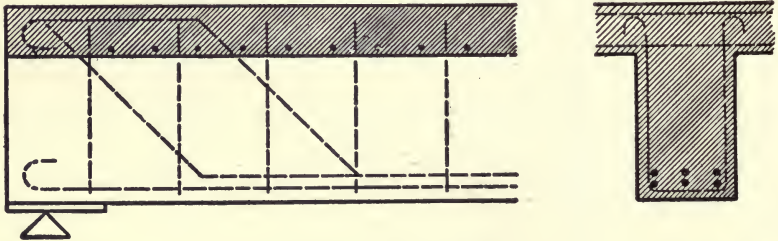

FIG. 55.—T-Beam Design.

Reinforcement for negative moment over the supports should be the same as for positive moment at mid-span, and will be provided by turning up every alternate bar at the quarter point on each side of the support and continuing them over the support to the one-third point. Transverse reinforcement to prevent cracks will be provided by using  $\frac{3}{8}$ -inch bars spaced 12 inches apart.

Unit shear at ends of slab,

$$v = \frac{V}{bjd} = \frac{300 \times 3}{12 \times .874 \times 3} = 28.6 \text{ lb./in.}^2$$

No diagonal tension reinforcement is necessary.

*T-beam.*—Assuming the weight of the web of the T-beam as 150 pounds per linear foot, the total load on the T-beam is  $6(250 + 47) + 150 = 1930$  pounds per linear foot. Taking the bearing upon the wall as 6 inches the effective length of T-beam between centers of bearings is  $17.5 + .5 = 18$  feet.



TABLE XV.—STEEL BARS, SPACING IN SLABS  
Sectional area per foot of slab—square inches.

| Diam. in Inches.   | Weight per Ft. Pounds. | Area Sq. In. | DISTANCES APART OF BARS—INCHES. |      |      |      |      |      |      |      |      |      |
|--------------------|------------------------|--------------|---------------------------------|------|------|------|------|------|------|------|------|------|
|                    |                        |              | 2                               | 2½   | 3    | 3½   | 4    | 4½   | 5    | 6    | 7    | 8    |
| <b>SQUARE BARS</b> |                        |              |                                 |      |      |      |      |      |      |      |      |      |
| 1/4                | 0.212                  | 0.0625       | 0.37                            | 0.30 | 0.25 | 0.21 | 0.19 | 0.17 | 0.15 | 0.12 | 0.11 | 0.09 |
| 5/16               | 0.333                  | 0.0977       | 0.59                            | 0.47 | 0.39 | 0.33 | 0.29 | 0.26 | 0.23 | 0.20 | 0.17 | 0.15 |
| 3/8                | 0.478                  | 0.1406       | 0.84                            | 0.67 | 0.56 | 0.48 | 0.42 | 0.37 | 0.34 | 0.28 | 0.24 | 0.21 |
| 7/16               | 0.651                  | 0.1914       | 1.15                            | 0.92 | 0.77 | 0.66 | 0.57 | 0.51 | 0.46 | 0.38 | 0.33 | 0.29 |
| 1/2                | 0.850                  | 0.2500       | 1.50                            | 1.20 | 1.00 | 0.86 | 0.75 | 0.67 | 0.60 | 0.50 | 0.43 | 0.37 |
| 9/16               | 1.076                  | 0.3164       | 1.90                            | 1.52 | 1.37 | 1.08 | 0.95 | 0.84 | 0.76 | 0.63 | 0.54 | 0.47 |
| 5/8                | 1.328                  | 0.3906       | 2.34                            | 1.87 | 1.56 | 1.34 | 1.17 | 1.04 | 0.94 | 0.78 | 0.67 | 0.59 |
| 11/16              | 1.608                  | 0.4727       | 2.84                            | 2.27 | 1.89 | 1.62 | 1.42 | 1.26 | 1.13 | 0.95 | 0.81 | 0.71 |
| 3/4                | 1.913                  | 0.5625       | 3.37                            | 2.70 | 2.25 | 1.93 | 1.69 | 1.50 | 1.35 | 1.12 | 0.96 | 0.84 |
| 7/8                | 2.603                  | 0.7656       |                                 | 3.67 | 3.06 | 2.62 | 2.30 | 2.04 | 1.84 | 1.53 | 1.31 | 1.15 |
| 1                  | 3.400                  | 1.0000       | 4.80                            |      | 4.00 | 3.43 | 3.00 | 2.67 | 2.40 | 2.00 | 1.71 | 1.50 |
| 1 1/8              | 4.303                  | 1.2656       |                                 |      | 5.06 | 4.34 | 3.80 | 3.37 | 3.04 | 2.53 | 2.17 | 1.89 |
| 1 1/4              | 5.312                  | 1.5625       |                                 |      |      | 5.36 | 4.69 | 4.17 | 3.75 | 3.12 | 2.68 | 2.34 |
| <b>ROUND BARS</b>  |                        |              |                                 |      |      |      |      |      |      |      |      |      |
| 1/4                | 0.167                  | 0.0491       | 0.29                            | 0.25 | 0.20 | 0.17 | 0.15 | 0.13 | 0.12 | 0.10 | 0.08 | 0.07 |
| 5/16               | 0.261                  | 0.0767       | 0.46                            | 0.36 | 0.31 | 0.26 | 0.23 | 0.20 | 0.18 | 0.15 | 0.13 | 0.12 |
| 3/8                | 0.375                  | 0.1104       | 0.66                            | 0.53 | 0.44 | 0.38 | 0.33 | 0.29 | 0.26 | 0.22 | 0.19 | 0.17 |
| 7/16               | 0.511                  | 0.1503       | 0.90                            | 0.72 | 0.60 | 0.51 | 0.45 | 0.40 | 0.36 | 0.30 | 0.26 | 0.23 |
| 1/2                | 0.667                  | 0.1963       | 1.18                            | 0.94 | 0.78 | 0.67 | 0.59 | 0.52 | 0.47 | 0.39 | 0.34 | 0.29 |
| 9/16               | 0.845                  | 0.2385       | 1.49                            | 1.19 | 0.99 | 0.85 | 0.75 | 0.66 | 0.60 | 0.50 | 0.43 | 0.37 |
| 5/8                | 1.043                  | 0.3068       | 1.84                            | 1.47 | 1.23 | 1.05 | 0.92 | 0.82 | 0.74 | 0.61 | 0.53 | 0.46 |
| 11/16              | 1.262                  | 0.3912       | 2.23                            | 1.78 | 1.48 | 1.27 | 1.11 | 0.99 | 0.89 | 0.74 | 0.64 | 0.56 |
| 3/4                | 1.502                  | 0.4418       | 2.65                            | 2.12 | 1.77 | 1.51 | 1.32 | 1.18 | 1.06 | 1.88 | 0.76 | 0.66 |
| 7/8                | 2.044                  | 0.6013       | 2.88                            | 2.40 | 2.06 | 2.06 | 1.80 | 1.60 | 1.44 | 1.20 | 1.03 | 0.90 |
| 1 1/8              | 2.670                  | 0.7854       | 3.77                            | 3.14 | 2.69 | 2.69 | 2.36 | 2.09 | 1.88 | 1.57 | 1.35 | 1.18 |
| 1 1/4              | 3.379                  | 0.9940       |                                 | 3.98 | 3.41 | 3.41 | 2.98 | 2.65 | 2.39 | 1.99 | 1.70 | 1.49 |
| 1 1/4              | 4.173                  | 1.2272       |                                 |      |      | 4.21 | 3.68 | 3.27 | 2.95 | 2.45 | 2.10 | 1.84 |

The maximum shear  $V=1930 \times 9=17370$  pounds. The area required for shear, assuming  $j=\frac{7}{8}$ ,  $b'd=\frac{V}{vj}=\frac{17370}{105}=165$  in.<sup>2</sup>

For  $b'=8$ ,  $d=21$  or for  $b'=9$ ,  $d=18.5$ . Take  $b'=9$ , and  $d=18.5$ .

$$M=\frac{\omega l}{8}=\frac{1900 \times 18 \times 18 \times 12}{8}=923400 \text{ in.-lb.}$$

Width of flange  $b=2 \times 6 \times 3\frac{3}{4}+9=54$  inches, and by (31)

$$Q=\frac{M}{btd}=\frac{923400}{54 \times 3.75 \times 18.5}=247; \quad \frac{d}{t}=4.95;$$

from Diagram I,  $f_c=430$  lb./in.<sup>2</sup>, and  $p=.0035$ , then

$$A=pbd=.0035 \times 54 \times 18.5=3.50 \text{ in.}^2,$$

and from Table X, six  $\frac{7}{8}$ -inch round bars in two rows, 2 inches c. to c., spaced 2.75 inches apart in the rows and 1.75 inches from side of web.  $A=3.61$  in.<sup>2</sup>

As the ends of the beam are built into the walls, some negative moment may be developed at the supports, which might cause cracks to occur unless reinforced. The upper layer of reinforcement will therefore be turned up, two rods at the quarter point and the other midway between the quarter point and support, and extend to the end of the beam (see Fig. 55).

If the concrete extend 2 inches below the steel, the weight of web below the slab is  $9(18.5+3-3.75) \times 150/144=166$  pounds per linear foot. This is a little greater than the assumed value, but would add less than 1 per cent to the total load and need not be redesigned. For the three bars in bottom of beam at the support. Table X gives  $\Sigma o=3 \times 2.75=8.25$ , and the unit bond stress  $u=b'v/\Sigma o=9 \times 120/8.25=131$  lb./in.<sup>2</sup> This is too great for safety, and the bars should be bent into hooks at the ends.

$v$  is 120 lb./in.<sup>2</sup> at the supports, and diagonal tension reinforcement is needed where  $v$  is more than 40 lb./in.<sup>2</sup> Stirrups will be needed for two-thirds of the distance from the support to the mid-span, or 6 feet. If the stirrups be spaced  $s=d/2=9$  inches apart, eight stirrups will be needed at each end of the beam. For the stirrups next the support (34)

$$A_v=\frac{vb's}{2f_s}=\frac{120 \times 9 \times 9}{2 \times 16000}=.31 \text{ in.}^2$$

Two  $\frac{1}{2}$ -inch round bars, bent as shown (Fig. 55) may be used for the first four stirrups, and  $\frac{3}{8}$ -inch bars for the four nearer the middle of the beam.

*Example 20.*—A reinforced concrete slab, to carry a live load of 200 pounds per square foot, is to rest upon a series of T-beams 5 feet apart c. to c. The T-beams are to be continuous for three spans over girders 15 feet c. to c. The girders are supported by walls at the ends and have a span of 20 feet. Design the slab and beams.

*Solution.*—Assume the weight of slab at 40 pounds per square foot; then  $M = \frac{240 \times 5 \times 5 \times 12}{12} = 6000$  in.-lb. From Table VII,  $R = 108$ ,  $p = .0078$ ,  $j = .874$ ,  $12d^2 = 6000/108 = 55.5$  and  $d = 2.15$ , Take  $d = 2.25$  in.  $A = 2.25 \times 12 \times .0078 = .21$  in.<sup>2</sup>

If concrete extend  $\frac{3}{4}$ -inch below steel, the total depth of slab is 3 inches, and weight of slab is  $150 \times \frac{3}{12} = 37.5$  pounds per square foot.

From Table XV  $\frac{5}{16}$ -inch round bars spaced 4 inches apart give  $A = .23$  in.<sup>2</sup> Negative moment at supports will be provided for by bending these up at the quarter points. For lateral reinforcement to prevent cracks,  $\frac{5}{16}$ -inch round bars spaced 12 inches c. to c. will be used.

*T-beams.*—Assuming weight of web of T-beam as 125 pounds per linear foot, load upon T-beam is  $5(200+40) + 125 = 1325$  pounds per linear foot and total span load is  $1325 \times 15 = 19,875$  pounds.

Maximum shear in end span next girder is  $V = 19,875 \times .6 = 11,925$  pounds, and  $b'd = V/jd = 11,925/105 = 113$  in.<sup>2</sup>  $7 \times 16$  or  $8 \times 14$  might be used. Try  $7 \times 16$ , then  $M = Wl/10 = 19,875 \times 15 \times 12/10 = 357,750$  in.-lb. Taking overhang of flange as six times its depth,  $b = 2 \times 6 \times 3 + 7 = 43$  inches and Formula (31)

$$Q = \frac{357750}{43 \times 3 \times 16} = 173, \quad d/t = 5.3.$$

From diagram I,  $f_c = 325$  lb./in.<sup>2</sup> and  $p = .0024$ .  $A = 1.65$  in.<sup>2</sup> Table X, six  $\frac{5}{8}$ -inch round bars,  $A = 1.84$  in.<sup>2</sup> in two rows,  $1\frac{3}{4}$  inches apart and spaced 2 inches c. to c. and 1.5 inches from side of web.

If concrete extends 2 inches below steel, the weight of web below slab is  $7 \times 16 \times 150/144 = 117$  pounds per linear foot, which is within the assumed load.

The negative moment at crossing of girder is equal to the positive moment already found. Turn up the upper row of bars on each side to provide for tension at top of beam and run the lower ones through at bottom to provide compression reinforcement as shown in Fig. 56. We now have a beam with compression reinforcement, in which  $b = 7$ ,  $d = 16$ ,  $d' = 3$ ,  $A = A' = 1.84$ ,  $p = p' = 1.84/112 = .0164$ ,  $d'/d = .18$ .



Formula (48) gives  $G = \frac{M}{bd^2} = \frac{357750}{7 \times 16 \times 16} = 200$ , and Table XII, for  $f_s = 16000$ ,  $f_c = 650$ ,  $G = 200$ , and  $d'/d = .18$ , we find that  $p = .0139$  and  $p' = .0219$  are required. The area of steel in compression ( $p = .0164$ ) is not sufficient and we must either increase the area of compression steel in the bottom of beam or increase the area of concrete section over the support. Try making  $d = 17$  inches. Then  $p = p' = 1.84/119 = .0157$ ,  $d'/d = 2.875/17 = .17$  and  $G = \frac{357750}{7 \times 17 \times 17} = 177$ . Now from Table XII, we find that  $p = .0123$  and  $p' = .0156$  are required. The reinforcement is now sufficient and we will increase

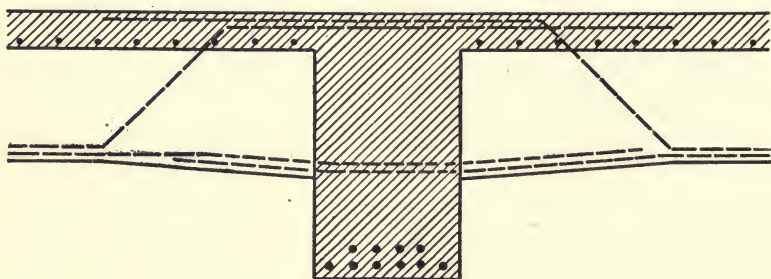

FIG. 56.—T-Beam and Girder.

the depth to 17 inches at the girder, sloping the haunches as shown in Fig. 56.

*Diagonal Tension.*—Assuming  $J$  as .85, the maximum unit shear next the girder is  $v = \frac{11925}{7 \times .85 \times 17} = 118$  lb./in.<sup>2</sup> If stirrups be spaced 8 inches apart, the area required for the end stirrups is (34)

$$A_v = \frac{118 \times 7 \times 8}{2 \times 16000} = .21 \text{ in.}^2$$

Two  $\frac{3}{8}$ -inch bars will answer, or a  $\frac{3}{8}$ -inch bar bent to U-shape around horizontal reinforcement. Stirrups will be needed to 6 feet from girder and 4 feet from end support in the end spans and 5 feet from girder on each end of the middle span.

*Girders.*—The girders are simple rectangular beams carrying three concentrated loads at the middle and quarter points. Each load is 1.1 times a span load of the T-beam, or  $1.1 \times 19875 = 21862$  pounds; assuming that the girder weighs 800 pounds per linear foot, the reaction or shear at the support is  $1.5 \times 21862 + 800 \times 10 = 40793$  pounds and the maximum bending moment  $M = 40,793 \times (120 - 29,862) \times 60 = 3,103,440$  in.-lb.  $bd^2 = 3,103,440/108 = 28,735$ . For

$b=20$ ,  $d=38$ ; for  $b=18$ ,  $d=40$ . Try  $b=18$ ,  $d=40$ ; then  $A=.0078 \times 18 \times 40 = 5.61 \text{ in.}^2$ . Ten  $\frac{3}{4}$ -inch square bars ( $A=5.62$ ) placed in two rows  $1\frac{3}{4}$  inches c. to c., six bars in lower and four in upper layer (Fig. 56). If concrete extend  $2\frac{1}{4}$  inches below center of lower layer of steel, the beam is 43 inches deep and weighs  $18 \times 43 \times 150 / 144 = 806$  pounds per linear foot, which agrees with the assumed weight.

The maximum unit shear  $v = \frac{40793}{18 \times .874 \times 40} = 65 \text{ lb./in.}^2$  Diagonal tension reinforcement will be needed from support to first load (60 inches). This may be supplied by bending up horizontal steel. The bending moment at first load is

$$40,793 \times 60 - 4000 \times 30 = 2,327,580 \text{ in.-lb.}$$

This is about three-fourths of the moment at the middle and two bars may be bent up at this point. For two bars  $A_d = 1.12 \text{ in.}^2$ , and Formula (15)

$$s = \frac{A_d f_s \sqrt{2}}{bv} = \frac{1.12 \times 16000 \times 1.4}{65 \times 18} = 21.5 \text{ inches.}$$

Turn up pairs of bars at 20, 40 and 60 inches from support.

The bond stress on four horizontal bars at end of beam is

$$u = \frac{bv}{\Sigma o} = \frac{18 \times 65}{4 \times 3} = 97 \text{ lb./in.}^2$$

This is rather large unless deformed bars are used, and bars should be bent into hooks at ends.

*Example 21.*—A reinforced concrete slab, divided into panels 12 ft.  $\times$  14 feet, by T-beam supports is to carry a live load of 150 pounds per square foot. The T-beams are supported by columns at the corners of the panels; their ends resting upon side walls. Design the slab and beams.

*Solution.*—Assume the weight of slab at 70 pounds per square foot. The proportion of load carried by the 12-foot span is  $14/12 - 0.5 = .67$  (see Section 117). The load on the slab in the 12-foot length is  $(150 + 70) \times .67 = 147 \text{ lb.}$  per square foot and in the 14-foot length  $220 \times .34 = 75 \text{ pounds}$  per square foot. If  $4/3$  of the average load per square foot be borne by the mid-section, the load to be carried by a 12-inch width will be  $147 \times 4/3 = 196 \text{ pounds}$  per linear foot.

$$M = \frac{\omega l^2}{12} = \frac{196 \times 12 \times 12 \times 12}{12} = 28,224 \text{ in.-lb.}$$

$12d^2 = 28224/108 = 261$  and  $d = 4.75$  inches. If the concrete extend  $\frac{3}{4}$  inch below steel, the total depth of slab will be 5.5 inches and the weight of slab  $150 \times 5.5/12 = 69$  pounds per square foot, as assumed.

$A = .0078 \times 12 \times 4.75 = .44$  in.<sup>2</sup> From Table XV,  $\frac{3}{8}$ -inch square bars spaced 3.5 inch c. to c. may be used.

Alternate bars in each span will be turned up at the quarter points for negative shear at the supports.

The side-sections of the shorter span will carry one-half the moment of the mid-sections, and will need about one-half the reinforcement. We will space the  $\frac{3}{8}$ -inch bars 6 inches apart for the side sections.

For the longer span (14 feet) the load upon the mid-section will be  $75 \times 4/3 = 100$  pounds per linear foot, and the bending moment

$$M = \frac{100 \times 14 \times 14 \times 12}{12} = 19,600 \text{ in.-lb.}$$

If we place the reinforcement in the 14-foot direction on top of that in the shorter span, the effective depth will be about  $\frac{1}{2}$ -inch less, or  $d = 4.75 - 0.5 = 4.25$  inches,

$$\text{and } R = \frac{M}{bd^2} = \frac{19600}{12 \times 4.25 \times 4.25} = 86.$$

From Table VII, we find that if  $f_s = 16,000$  and  $R = 86$ ,  $p = .006$  and  $f_c = 565$  lb./in.<sup>2</sup>  $A = .006 \times 12 \times 4.25 = .306$  in.<sup>2</sup> and Table XV gives  $\frac{3}{8}$ -inch round bars spaced 4 inches apart,  $A = .33$  in.<sup>2</sup> Use these for mid-half of slab and bars of the same size spaced 7 inches apart for the side-sections.

*T-Beams.*—Assuming the longer T-beam to weigh 250 pounds per linear foot, the total load will be  $196 \times 12 \times 14 + 250 \times 14 = 36,428$  pounds. The maximum shear will be  $V = 36,428 \times .6 = 21,857$  pounds and section needed for shear  $b'd = 21,857/105 = 208$  in.<sup>2</sup> Try  $b' = 10$ ,  $d = 21$  inches.

The load at the middle of the beam is greater than that at the ends; this somewhat increases the moment, but the error will not be more than about 2 per cent if the load be taken as uniformly distributed.

$$M = \frac{\omega l}{10} = \frac{35428 \times 14 \times 12}{10} = 611,990 \text{ in.-lb.}$$

Taking the width of flange as one-fourth the length of beam  $b = 45$  in.

$$Q = \frac{M}{bt d} = \frac{611990}{45 \times 5.5 \times 21} = 118, \quad d/t = 21/5.5 = 3.8.$$

From Diagram I, we find that the neutral axis is in the flange and the beam should be designed as a rectangular section.

$$R = \frac{M}{bd^2} = \frac{611990}{45 \times 21 \times 21} = 29.$$

From Table VII for  $f_s = 16000$ , and



$R=29$ , we see that  $f_c$  will be less than 350 lb./in.<sup>2</sup> and the steel needed is  $p=.0021$  ( $p=7R/100000$  approximately) or  $A=.0021 \times 45 \times 20=1.89$  in.<sup>2</sup> Four  $\frac{1}{16}$ -inch square bars may be used. Two of these bars to be turned up at the quarter point on each side of the support to provide for tension due to negative moment.

We now have at the support a double reinforced beam in which  $b=10$  inches,  $d=21$  inches,  $A=A'=1.89$  in.<sup>2</sup>,  $p=p'=1.89/210=.0090$ ,  $d'=2$  inches,  $d'/d=.095$  and  $G=\frac{611990}{10 \times 21 \times 21}=136$ . From Table XII, for  $f_s=16,000$ ,  $f_c=650$ ,  $G=136$  and  $d'/d=.095$  we find that  $p=.0096$  and  $p'=.0042$  are required. The reinforcement for tension is a little small, but as the beam will be strengthened by the slab reinforcement parallel to it, the  $\frac{1}{16}$ -inch bars will probably be ample.

Diagonal tension reinforcement will be needed for 5 feet from the supports. If stirrups be spaced 9 inches apart, seven stirrups will be needed. The first stirrup will require

$$A_v = \frac{vb's}{2f_s} = \frac{120 \times 10 \times 9}{2 \times 16000} = .34 \text{ in.}^2;$$

$\frac{1}{2}$ -inch round bars bent to U-shape will answer for the first three stirrups, the four next the middle of the beam may be  $\frac{3}{8}$ -inch.

The loads upon the shorter beams, assuming the beam to weigh 150 pounds per foot, are  $100 \times 14 \times 12 + 150 \times 12 = 18600$  pounds. The maximum shear is  $18600 \times .6 = 11160$  pounds.  $b'd = 11160/105 = 106$ . A section 7 inches  $\times$  16 inches might be used, but assuming that the depth must be the same as for the longer beams, we may use 7 inches  $\times$  21 inches. Then

$$M = \frac{18600 \times 12 \times 12}{10} = 267840 \text{ in.-lb.}, \text{ and } b=l/4 = 36 \text{ inches.}$$

As before, the neutral axis is in the flange,  $R = \frac{267840}{36 \times 21 \times 21} = 17$ , and Table VII,  $f_c$  will be small and  $p=.0012$ .  $A=.0012 \times 36 \times 21 = 0.90$  in.<sup>2</sup> Three  $\frac{5}{8}$ -inch round bars will be used. Part of these bars will be turned up, two on one side and one on the other of each support to provide for tension due to negative moment. Then

$$G = \frac{267840}{7 \times 21 \times 21} = .87, \quad d'/d = .095,$$

and from Table XII we find that no compression steel is necessary.

Maximum unit shear,  $v = \frac{11160}{7 \times 21 \times .875} = 87$  lb./in.<sup>2</sup> Diagonal

tension reinforcement is needed  $72 \times 47 / 87 = 40$  inches from support. Spacing stirrups 10 inches apart, for end stirrups

$$A_v = \frac{87 \times 10 \times 10}{2 \times 16000} = .27 \text{ in.}^2$$

Use  $\frac{3}{8}$ -inch square bars bent to U-shape.

### ART. 32. CONCRETE COLUMNS

**119. Plain Concrete Columns.**—The strength of plain concrete in compression has been discussed in Section 94. The failure of a short block under compression occurs through lateral expansion and the shearing of the material on surfaces making angles of about  $30^\circ$  with the line of pressure as shown in Fig. 57 (a). As the height of block becomes greater in proportion to its diameter, the resistance of the concrete becomes less certain and plain columns in which the length is more than four times the height frequently fail by shearing diagonally across the column as shown in Fig. 57 (b). This usually

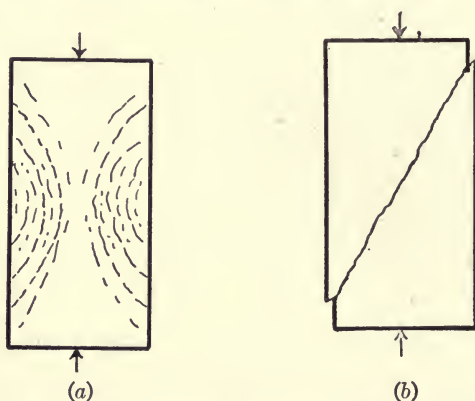

FIG. 57.—Crushing of Concrete Columns.

occurs where the concrete is of good quality and shows high crushing strength. Weaker concrete usually fails by local crushing.

Columns in which the lengths are more than six or eight times the diameters are usually reinforced. The Joint Committee recommends that all columns more than four diameters be reinforced, and that the stress on plain columns be limited to 22.5 per cent of the ultimate crushing strength of the concrete.

The use of concrete rich in cement is nearly always advisable in the construction of columns, on account of the greater reliability of such concrete, as well as because of the economy of reduced section

allowable with rich concrete. In reinforced columns, concrete of high compressive strength also admits of more economical use of steel, through employing higher unit stresses than are admissible with less rich concrete. Concrete less rich than 1 to 6 (2000 pounds) mixtures (see Section 94) is undesirable in column work and richer mixtures are commonly preferable.

**120. Longitudinal Reinforcement.**—Longitudinal bars in the corners of square columns, or near the exterior surfaces of round columns, diminish the uncertainty of action of the columns through preventing the material yielding at points of local weakness. Such reinforcement should always be stayed by light band reinforcement at frequent intervals as shown in Fig. 58 (a). This will prevent the longitudinal bars breaking away from the column through bending when loaded.

When a column containing longitudinal steel is loaded, the concrete and steel are shortened by the compression to the same extent and the stress carried by each material is proportional to its modulus of elasticity.

- Let  $A$  = cross-section of column;
- $A_s$  = cross-section of steel;
- $p$  = steel ratio =  $A_s/A$ ;
- $n$  = ratio of moduli of elasticity =  $E_s/E_c$ ;
- $P$  = total load on columns;
- $f_c$  = unit compression on concrete;
- $f_s$  = unit compression on steel =  $nf_c$ .

The total area of concrete is  $A(1-p)$ , and

$$P = f_c A(1-p) + f_s A_s = f_c(A - pA) + f_s n p A,$$

or

$$P = f_c A[1 + (n-1)p]. \quad \dots \dots \dots (50)$$

The Joint Committee recommends the following working stresses:

- (a) Columns with longitudinal reinforcement to the extent of not less than 1 per cent and not more than 4 per cent, and with lateral ties of not less than  $\frac{1}{4}$  inch in diameter 12 inches apart, nor more than 16 diameters of the longitudinal bar: the unit stress recommended for axial compression, on concrete piers having a length not more than four diameters.

The Committee also recommends that the ratio of unsupported length of column to its least width be limited to 15, and that the hoops or bands are not to be counted on directly as adding to the strength of the column.



In Formula (50), if we let  $Z=1+(n-1)p=\frac{P}{f_c A}$ , and tabulate values of  $Z$  (see Table XVI) in terms of  $n$  and  $p$ , the computation of columns of this type becomes very simple.

TABLE XVI.—COLUMNS WITH LONGITUDINAL REINFORCEMENT

Values of  $Z=\frac{P}{f_c A}$ , in Terms of  $n$  and  $p$

| $p$   | $n=10$ | $n=12$ | $n=15$ | $p$   | $n=10$ | $n=12$ | $n=15$ |
|-------|--------|--------|--------|-------|--------|--------|--------|
| 0.006 | 1.054  | 1.066  | 1.084  | 0.021 | 1.189  | 1.231  | 1.294  |
| 0.007 | 1.063  | 1.077  | 1.098  | 0.022 | 1.198  | 1.242  | 1.308  |
| 0.008 | 1.072  | 1.088  | 1.112  | 0.023 | 1.207  | 1.253  | 1.322  |
| 0.009 | 1.081  | 1.099  | 1.126  | 0.024 | 1.216  | 1.264  | 1.336  |
| 0.010 | 1.090  | 1.110  | 1.140  | 0.025 | 1.225  | 1.275  | 1.350  |
| 0.011 | 1.099  | 1.121  | 1.154  | 0.026 | 1.234  | 1.286  | 1.364  |
| 0.012 | 1.108  | 1.132  | 1.168  | 0.027 | 1.243  | 1.297  | 1.378  |
| 0.013 | 1.117  | 1.143  | 1.182  | 0.028 | 1.252  | 1.308  | 1.392  |
| 0.014 | 1.126  | 1.154  | 1.196  | 0.029 | 1.261  | 1.319  | 1.406  |
| 0.015 | 1.135  | 1.165  | 1.210  | 0.030 | 1.270  | 1.330  | 1.420  |
| 0.016 | 1.144  | 1.176  | 1.224  | 0.032 | 1.288  | 1.352  | 1.448  |
| 0.017 | 1.153  | 1.187  | 1.238  | 0.034 | 1.306  | 1.374  | 1.476  |
| 0.018 | 1.162  | 1.198  | 1.252  | 0.036 | 1.324  | 1.396  | 1.504  |
| 0.019 | 1.171  | 1.209  | 1.266  | 0.038 | 1.342  | 1.418  | 1.532  |
| 0.020 | 1.180  | 1.220  | 1.280  | 0.040 | 1.360  | 1.440  | 1.560  |

*Example 22.*—A square column is to carry a load of 95,000 pounds, and to be reinforced with 2 per cent of longitudinal steel. If  $f_c=450$  lb./in. and  $n=15$ , find dimensions for column and steel.

*Solution.*—From Table XVI, for  $n=15$  and  $p=.020$ , we find  $Z=1.280$ . Then  $A=\frac{P}{f_c Z}=165$ , and side of column = 13 inches.  $A_s=.020 \times 165=3.30$  in.<sup>2</sup> From Table X, four  $\frac{15}{16}$ -inch square bars may be used,  $A_s=3.52$  inches.

If 1 to 3 concrete of 3000 pounds compressive strength (see Section 94) were used in the above problem, we would have  $f_c=675$ ,  $n=10$ ,  $Z=1.18$ ,  $A=119$  in.<sup>2</sup> and  $A_s=2.38$  in.<sup>2</sup> The quantities of materials required would be reduced about 25 per cent, while the proportion of cement in the concrete would be about doubled.

*Example 23.*—A column 14 in.  $\times$  14 in. section is to carry a load of 130 000 pounds. If  $f_c=450$  and  $n=15$  find area of steel required.

*Solution.*— $Z = \frac{P}{f_c A} = \frac{130000}{450 \times 14 \times 14} = 1.474$  and from Table XVI,  $p = .034$ . Then  $A_s = .034 \times 14 \times 14 = 6.66 \text{ in.}^2$  This might be four  $1\frac{1}{2}$ -inch round bars at the corners ( $A_s = 7.07$ ), or eight  $\frac{1}{8}$ -inch square bars at corners and middle of sides ( $A_s = 7.03$ ), or four  $1\frac{1}{4}$ -inch round bars at corners and four  $\frac{3}{4}$ -inch round bars at middle of sides. ( $A_s = 6.68 \text{ in.}^2$ ).

The Joint Committee recommends a minimum of 1 per cent of longitudinal steel for columns of more than four diameters in length. This gives rigidity to the column, and security against local yielding in the concrete. High percentages of longitudinal steel are not

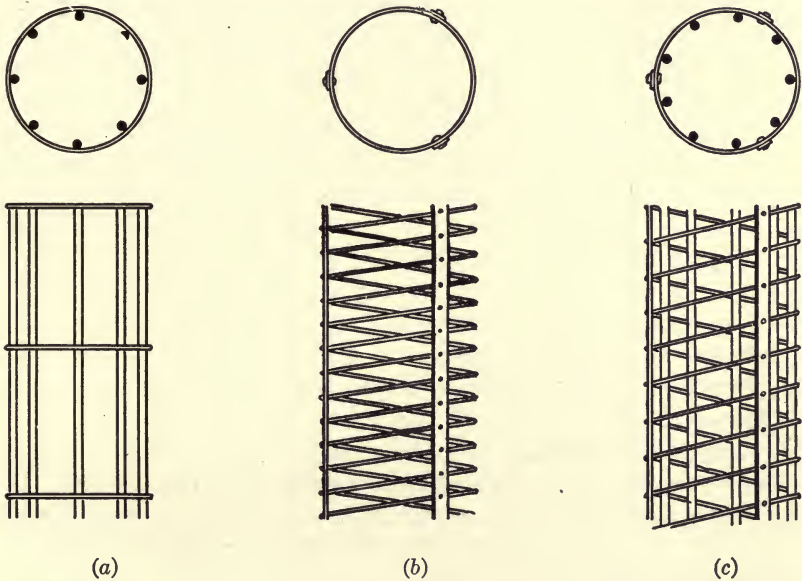

FIG. 58.—Reinforced Concrete Columns.

usually economical, because of the greater cost of steel as compared with concrete for resisting compression, particularly when the stresses in the steel are limited by those in the concrete.

When the concrete is used for fireproofing, the steel should be covered by at least 2 inches of concrete, and about  $1\frac{1}{2}$  inches of concrete on the exterior of the column should not be considered in determining the strength of the column.

**121. Columns with Hooped Reinforcement.**—As shown in Section 95, the failure of concrete under compression commonly occurs through shearing due to lateral expansion. If the concrete in the column be held by band or spiral steel (see Fig. 58 (b)) from yielding to

lateral expansion, the resistance to crushing will be materially increased. Such reinforcement is either formed of steel bars bent to form a spiral or bands of steel spaced at a uniform distance apart, but in either case, the bands should not be spaced more than about one-sixth of the diameter of the column apart, and must be held in place by longitudinal spacing bars.

Experiments upon columns with hooped reinforcement indicate that the deflections under working loads are not decreased by the reinforcement, but the ultimate strength is considerably increased, as compared with columns without such reinforcement. When hooped reinforcement is used, it is usual to allow a larger unit stress than for plain columns, or those with longitudinal reinforcement only. The effective area of the column is that inside the reinforcement. The concrete outside the hooping is stripped off when a stress is reached at which plain concrete would fail.

Hooped reinforcement prevents crushing of the concrete until a load is reached which stresses the steel to its yield point, but does not stiffen the column longitudinally, and columns so reinforced frequently fail by bending. This reinforcement is commonly combined with longitudinal steel as shown in Fig. 58 (c). The longitudinal steel serves to stiffen the column against bending, and makes the hooping more effective. In general, it is not advisable to use hooped reinforcement without longitudinal steel, as the same amount of steel would be more effective in strengthening the column if used as longitudinal steel.

Experiments indicate that about 1 per cent of steel in closely spaced hooping is sufficient to resist lateral expansion and give increased strength in compression. Larger amounts of steel do not materially increase the resistance. The Joint Committee makes the following recommendations:

- (b) Columns reinforced with not less than 1 per cent and not more than 4 per cent of longitudinal bars and with circular hoops or spirals not less than 1 per cent of the volume of the concrete and as hereinafter specified: a unit stress 55 per cent higher than given for (a), provided the ratio of unsupported length of column to diameter of the hooped core is not more than 10.

The foregoing recommendations are based on the following conditions:

It is recommended that the minimum size of columns to which the working stresses may be applied be 12 inches out to out.

In all cases longitudinal reinforcement is assumed to carry its proportion of stress. The hoops or bands are not to be counted on directly as adding to the strength of the column.

Longitudinal reinforcement bars should be maintained straight, and should



have sufficient lateral support to be securely held in place until the concrete has set.

Where hooping is used, the total amount of such reinforcement shall be not less than 1 per cent of the volume of the column, enclosed. The clear spacing of such hooping shall be not greater than one-sixth the diameter of the enclosed column and preferably not greater than one-tenth, and in no case more than 2 inches. Hooping is to be circular and the ends of bands must be united in such a way as to develop their full strength. Adequate means must be provided to hold bands or hoops in place so as to form a column, the core of which shall be straight and well centered. The strength of hooped columns depends very much upon the ratio of length to diameter of hooped core, and the strength due to hooping decreases rapidly as this ratio increases beyond five. The working stresses recommended are for hooped columns with a length of not more than ten diameters of the hooped core.

The Committee has no recommendation to make for a formula for working stresses for columns longer than ten diameters.

- Let  $d$  = effective diameter of column in inches;
- $a$  = area of the steel bar to be used, in square inches;
- $s$  = longitudinal spacing of the bands or spirals, in inches;
- $p$  = ratio of steel to concrete in column.

Then

$$a = pds/4$$

or

$$s = 4a/pd \dots \dots \dots (51)$$

From this we may obtain the size of bars necessary for steel of required spacing, or the spacing required for bars of given size.

*Example 24.*—A concrete column is to carry a load of 225,000 pounds and be reinforced with 1 per cent of spiral steel and 2 per cent of longitudinal steel. Using the stresses recommended by the Joint Committee for concrete of 2000 pounds compressive strength, find dimensions for concrete and steel.

*Solution.*—Without hooped reinforcement, the value of  $f_c$  would be limited to 22.5 per cent of the compressive strength, or 450 lb./in. This may be increased 55 per cent when spiral reinforcement is used or  $f_c = 700$  lb./in.<sup>2</sup>

Using Table XVI, for  $p = .02$  and  $n = 15$ ,  $Z = 1.28$ , from which  $A = \frac{P}{f_c Z} = \frac{225000}{700 \times 1.28} = 251$  in.<sup>2</sup>, and diameter of column is 18 inches. Longitudinal steel,  $A_s = .02 \times 251 = 5.02$  in.<sup>2</sup> From Table X we see that five 1-inch square bars, spaced about 11 inches apart about the circumference of the column, or nine  $\frac{3}{4}$ -inch square bars spaced about 6 inches apart may be used. For the spiral steel, we find from (51) that if the spacing be made  $2\frac{1}{2}$  inches,  $a = .01 \times 18 \times 2\frac{1}{2} / 4 = .112$  in.<sup>2</sup>, and  $\frac{3}{8}$ -inch round bars may be used.

**122. Eccentrically Loaded Columns.**—When the center of gravity of the load upon a column does not coincide with the gravity axis of the column, bending stresses are produced which must be taken into account in designing the column. In some cases, lateral forces may be acting upon a column, producing bending moments, as in wall columns carrying the ends of beams which are firmly attached to the columns. When these conditions exist, the maximum unit compression due to both direct thrust and bending moment at any section must not exceed the safe values for the concrete, and any tensions which may occur must be taken by proper reinforcement.

Let Fig. 59 represent the section of a column under eccentric load.

$A$  = area of section of column;

$A_s$  = area of longitudinal steel in section;

$P$  = longitudinal load on column;

$e$  = eccentricity of load;

$I_c$  = moment of inertia of section about its gravity axis;

$I_s$  = moment of inertia of steel area about same axis;

$u$  = distance gravity axis to most remote edge of section;

$M$  = bending moment on section,  $Pe$ ;

$f_c$  = maximum unit compression on concrete;

$f'_c$  = minimum unit compression on concrete.

$f_c$  = is made up of two parts—that due to direct thrust and that due to bending moment, and is

$$f_c = \frac{P}{A + (n-1)A_s} + \frac{Mu}{I_c + (n-1)I_s}, \quad \dots \quad (51)$$

and

$$f'_c = \frac{P}{A + (n-1)A_s} - \frac{Mu}{I_c + (n-1)I_s}. \quad \dots \quad (52)$$

When the stress due to moment is greater than that due to direct thrust,  $f'_c$  becomes negative, showing the stress to be tension. Tensions in columns, if occurring at all, should be very small and need not be specially provided for. The stresses in steel are always less than  $nf_c$ , and therefore within safe limits.

If the section is symmetrical about its gravity axis,  $u = d/2$ , and for rectangular sections,  $I_c = \frac{bd^3}{12}$  and  $I_s = A_s d_s^2/4$ , in which  $d_s$  is distance between centers of steel on the two sides of column. For circular sections,  $I_c = .049d^4$  and  $I_s = .125A_s d_s^2$ , where  $d$  is the diameter of the column and  $d_s$  is diameter of the circle containing the centers of the steel bars.

*Example 25.*—A wall column, 12×16 inches in section, carries the end of a beam which brings a longitudinal load of 60,000 pounds and a bending moment of 180,000 in.-lb. upon the column. The column is reinforced with four 1-inch square steel bars at the corners, the centers of steel being 2 inches from surfaces of concrete.  $n=15$ . Find the unit stresses on the concrete.

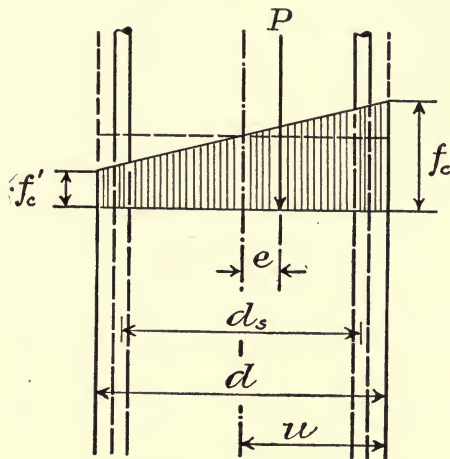

FIG. 59.—Column with Eccentric Load.

*Solution.*—

$$I_c = 12 \times 16 \times 16 \times 16 / 12 = 4096. \quad I_s = 4 \times 12 \times 12 / 4 = 144.$$

$$f_c = \frac{60000}{192 + 14 \times 4} + \frac{180000 \times 8}{4096 + 14 \times 144} = 242 + 235 = 477 \text{ lb./in.}^2,$$

$$f'_c = 242 - 235 = 7 \text{ lb/in.}^2$$

Complete discussions of the principles of reinforced concrete design with applications to structures is given in "Concrete, Plain and Reinforced," by Taylor and Thompson, and in "Principles of Reinforced Concrete Construction," by Turneure and Maurer.



## CHAPTER VII

### RETAINING WALLS

#### ART. 33. PRESSURE OF EARTH AGAINST A WALL.

**123. Theories of Earth Pressure.**—The lateral pressure of a mass of earth against a retaining wall is affected by so many variable conditions that the determination of its actual value in a particular instance is practically impossible.

Several theories, based in each case upon certain ideal conditions, have been proposed, none of which are more than very rough approximations to the conditions existing in such structures. These theo-

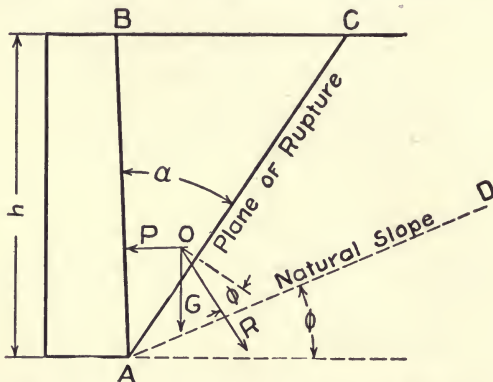

FIG. 60.—Pressure of Earth against a Wall.

ries assume that the earth is composed of a mass of particles exerting friction upon each other but without cohesion, or that the pressure against the wall is caused by a wedge of earth which tends to slide upon a plane surface of rupture, as shown in Fig. 60. Formulas for the resultant thrust against the wall have been produced in accordance with the various theories by several methods, they differ mainly in the direction given to the thrust upon the wall.

*Coulomb's Theory.*—A formula for computing the lateral thrust against a wall was proposed by Coulomb in 1773. Coulomb assumed that the thrust was caused by a prism of earth ( $BAC$ , Fig. 60) sliding

upon any plane  $AC$  which produces the maximum thrust upon the wall. There is a certain slope ( $AD$ , Fig. 60) at which the material if loosely placed will stand. This is known as the natural slope, and the angle made by this slope with the horizontal as the angle of friction of the earth. On slopes steeper than the natural slope, there is a tendency for the earth to slide down, and if held by a wall, pressures are produced which depend upon the frictional resistance to sliding.

The thrust is assumed by Coulomb to be normal to the wall, and the pressure upon the plane of rupture to be inclined at the angle of friction to the normal to the plane.

Let  $h$  = height of wall;

$P$  = resultant pressure upon a unit length of wall;

$R$  = pressure upon the plane of rupture;

$G$  = weight of the wedge of earth;

$e$  = weight of earth per cubic foot;

$\phi$  = angle of friction of earth;

$\alpha$  = angle between the back of wall and plane of rupture.

If the back of the wall be vertical and the surface of earth horizontal, from Fig. 60,

$$P = G \tan R \text{OG} = \frac{1}{2}eh^2 \cdot \frac{\tan \alpha}{\tan (\alpha + \phi)}.$$

For maximum value of  $P$ ,  $\alpha = 45^\circ - \frac{\phi}{2}$ , and the plane of rupture bisects the angle between the back of the wall and the natural slope. Substituting this value,

$$P = \frac{1}{2}eh^2 \tan^2 \left( 45^\circ - \frac{\phi}{2} \right).$$

$P$  varies as the square of  $h$ , and is therefore applied at a distance  $h/3$  above the base of the wall. This is the same in all of the theories.

*Poncelet's Theory.*—In 1840 Poncelet proposed to modify the method of Coulomb by making the thrust upon the wall act at the angle of friction with the normal to the wall.

Before the wall can be overturned about its toe ( $F$ , Fig. 61) the back of the wall ( $AB$ ) must be raised and slide upon the earth behind it, thus calling into play the friction of the earth upon the wall as a resistance. As the friction of earth upon a rough masonry wall is greater than that of earth upon earth, a film of earth would be carried with the wall and slide upon the earth behind and the angle of friction is usually taken as equal to the natural slope of the earth.

Let  $\theta$  = the angle made by the back of the wall with the horizontal;  
 $i$  = the angle made by the earth surface with the horizontal.

Following the same procedure as in developing Coulomb's formula, we find the pressure against the wall,

$$P = \frac{1}{2}eh^2 \frac{\sin^2(\theta - \phi)}{\sin^2 \theta, \sin(\theta + \phi) \left( l + \sqrt{\frac{\sin(\phi - i), \sin 2\phi}{\sin(\theta - i), \sin(\theta + \phi)}} \right)^2}$$

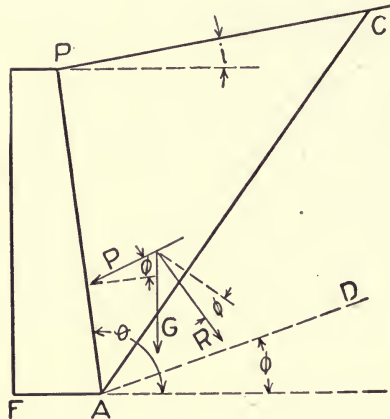

FIG. 61.—Poncelet's Theory of Pressure.

For a vertical wall and horizontal earth surface ( $\theta = 90^\circ$  and  $i = 0^\circ$ ),

$$P = \frac{eh^2}{2} \cdot \frac{\cos \phi}{(l - \sqrt{2} \cdot \sin \phi)^2},$$

which is the formula proposed by Poncelet.

*Rankine's Theory.*—Rankine considered the earth to be made up of a homogeneous mass of particles, possessing frictional resistance to sliding over each other but without cohesion. He deduced formulas for the pressure upon ideal plane sections through an unlimited mass of earth with plane upper surface, the earth being subject to no external force except its own weight, and determined the direction of the pressure from these assumptions.

Rankine found that the resultant pressure upon any vertical plane section through a bank of earth with plane upper surface is parallel to the slope of the upper surface (see Fig. 62).

Let  $E$  = the pressure upon the vertical section;  
 $i$  = the angle made by the inclination of the upper surface with the horizontal;



- $\phi$  = the angle of friction of the earth;
- $e$  = the weight per cubic foot of the earth;
- $S$  = the height of vertical section through earth.

Then

$$E = \frac{eS^2}{2} \cos i \cdot \frac{\cos i - \sqrt{\cos^2 i - \cos^2 \phi}}{\cos i + \sqrt{\cos^2 i - \cos^2 \phi}}$$

is Rankine's formula for earth pressure. This pressure acts upon the vertical section at a distance  $S/3$  from its base, and makes an angle  $i$  with the horizontal.

Rankine's formula may be produced in the same manner as Poncelet's by assuming the pressure parallel to the upper slope.

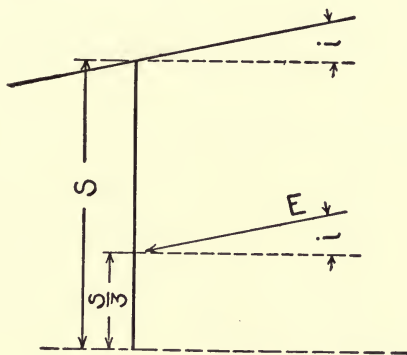

FIG. 62.—Pressure of Earth

Thus in Fig. 61 if the angle made by  $P$  with the normal to the wall be equal to  $i$ , we find

$$P = \frac{eS^2}{2} \cdot \frac{\cos^2 \phi}{\cos i \left( l + \sqrt{\frac{\sin(\phi - i) \sin(\phi + i)}{\cos^2 i}} \right)^2}$$

which may be transformed <sup>1</sup> into Rankine's formula as given above.

*Weyrauch's theory* is practically the same as Rankine's although produced in a different way.

*Cohesion*.—In all of the ordinary formulas for earth pressure, the effect of cohesion is neglected. Experiments indicate that this effect is not sufficient to affect very materially the actual pressure upon a wall. It causes the earth to break off and slide upon a concave surface instead of a plane surface. At the upper surface of the earth, the cohe-

<sup>1</sup> Wm. Cain, Practical Designing of Retaining Walls, 1914, p. 103.

sion is sufficient to overcome the lateral thrust and cause the earth to stand in a vertical position, while as the lateral thrust increases with the depth, the cohesion becomes relatively less important and the surface of rupture flattens out. When earth is placed behind a wall after it is constructed cohesion is probably negligible at first, although after the earth has become compacted may develop in some cases so that practically no pressure comes against the wall. It is so uncertain that no reliance should be placed upon it in designing walls.

*Value of Theories.*—On account of the variable nature of the material, it is evident that estimates of earth pressures are only rough approximations to the actual pressures. The material assumed as possessing uniform friction and without cohesion does not exist in practice. The general laws developed, however, do give rational methods of reaching reasonable estimates upon which safe designs may be based.

Experiments upon sand pressures, and experience with walls in use, indicate that Coulomb's use of horizontal earth pressures, or Rankine's thrust parallel to earth surface, where the surface is near the horizontal, give thrusts much greater than those actually produced upon walls with vertical backs. For such walls, the use of the Poncelet's formulas, taking into account the friction of the earth on the back of the wall, give results which seem to agree fairly well with experiment and experience.

For walls leaning forward, so that considerable weights of earth rest upon them, Rankine's formulas may be applied to find the thrust upon the vertical section through the earth at the inner edge of the base of the wall. This thrust, combined with the weight of earth resting upon the wall, gives the thrust against the wall.

**124. Computation of Earth Thrusts.**—When the back of a wall is nearly vertical, the thrust may usually be taken as making the angle of friction with a normal to the surface of the wall, as assumed in the theory of Poncelet. For such walls the thrust may be obtained from the formula already given:

$$P = \frac{eh^2}{2} \cdot \frac{\sin^2(\theta - \phi)}{\sin^2 \theta \cdot \sin(\theta + \phi) \left( 1 + \sqrt{\frac{\sin(\phi - i) \cdot \sin 2\phi}{\sin(\theta - i) \sin(\theta + \phi)}} \right)^2} \quad (1)$$

If we place  $P = \frac{eh^2}{2} Q$ , values of  $Q$  may be tabulated for various slopes and angles of friction as shown in Table XVII. The values of  $P$  obtained by this method are supposed to act against the wall at a

distance  $h/3$  above the base, and make the angle of friction with the normal to the wall.

TABLE XVII.—EARTH PRESSURE AGAINST A WALL

Values of  $Q$  in Formula (1),  $P = \frac{eh^2}{2} \cdot Q$

| Batter of Back of Wall.            | SLOPE OF UPPER SURFACE OF EARTH. |                         | ANGLE OF FRICTION, $\phi$ . |       |       |     |     |     |
|------------------------------------|----------------------------------|-------------------------|-----------------------------|-------|-------|-----|-----|-----|
|                                    | Angle $i$ .                      | Vertical to Horizontal. | 20°                         | 25°   | 30°   | 35° | 40° | 45° |
| Vertical<br>$\theta = 90^\circ$    | 33° 40'                          | 1 to 1½                 | .....                       | ..... | ..... | .59 | .39 | .28 |
|                                    | 29° 45'                          | 1 to 1¾                 | .....                       | ..... | .76   | .45 | .34 | .25 |
|                                    | 26° 30'                          | 1 to 2                  | .....                       | ..... | .54   | .39 | .32 | .23 |
|                                    | 21° 50'                          | 1 to 2½                 | .....                       | .61   | .46   | .35 | .30 | .22 |
|                                    | 18° 30'                          | 1 to 3                  | .72                         | .52   | .40   | .33 | .28 | .21 |
|                                    | 14° 00'                          | 1 to 4                  | .58                         | .45   | .36   | .30 | .25 | .19 |
|                                    | 0° 00'                           | Level                   | .43                         | .37   | .30   | .26 | .21 | .18 |
| 1 in 10<br>$\theta = 95^\circ 40'$ | 33° 40'                          | 1 to 1½                 | .....                       | ..... | ..... | .72 | .50 | .37 |
|                                    | 29° 40'                          | 1 to 1¾                 | .....                       | ..... | .90   | .56 | .44 | .35 |
|                                    | 26° 30'                          | 1 to 2                  | .....                       | ..... | .64   | .49 | .40 | .32 |
|                                    | 21° 50'                          | 1 to 2½                 | .....                       | .70   | .56   | .44 | .36 | .30 |
|                                    | 18° 30'                          | 1 to 3                  | .82                         | .60   | .48   | .40 | .34 | .28 |
|                                    | 14° 00'                          | 1 to 4                  | .66                         | .52   | .40   | .35 | .31 | .25 |
|                                    | 0° 00'                           | Level                   | .48                         | .40   | .34   | .30 | .26 | .22 |
| 1 in 5<br>$\theta = 101^\circ 20'$ | 33° 40'                          | 1 to 1½                 | .....                       | ..... | ..... | .91 | .62 | .49 |
|                                    | 29° 45'                          | 1 to 1¾                 | .....                       | ..... | 1.08  | .68 | .55 | .46 |
|                                    | 26° 30'                          | 1 to 2                  | .....                       | ..... | .77   | .60 | .50 | .42 |
|                                    | 21° 50'                          | 1 to 2½                 | .....                       | .80   | .66   | .54 | .45 | .38 |
|                                    | 18° 30'                          | 1 to 3                  | .93                         | .68   | .57   | .48 | .42 | .36 |
|                                    | 14° 00'                          | 1 to 4                  | .75                         | .60   | .48   | .41 | .38 | .32 |
|                                    | 0° 00'                           | Level                   | .52                         | .46   | .40   | .34 | .30 | .27 |

When a mass of earth rests upon a wall, as in a wall with sloping back or a reinforced concrete wall, the formula of Rankine for pressure upon a vertical section may be applied. This pressure combined with the weight of the earth resting upon the wall gives the thrust against the wall.

The value of the pressure upon the vertical section is given by Rankine's formula:

$$E = \frac{eS^2}{2} \cdot \cos i \cdot \frac{\cos i - \sqrt{\cos^2 i - \cos^2 \phi}}{\cos i + \sqrt{\cos^2 i - \cos^2 \phi}} = \frac{eS^2}{2} K. \quad (2)$$



Values of  $K$  corresponding to various values of  $i$  and  $\phi$  are tabulated in Table XVIII, thus greatly reducing the labor of computing the pressures.  $E$  as computed from this formula is supposed to act at a distance  $S/3$  from the bottom of the section and to be parallel to the upper surface of the earth.  $S$  in this formula is the height of the earth section and not the height of the wall.

TABLE XVIII.—PRESSURES UPON VERTICAL SECTIONS THROUGH EARTH

$$\text{Values of } K \text{ in Formula (2) } - E = \frac{eS^2}{2} K$$

| SLOPE OF UPPER SURFACE OF EARTH. |                         | ANGLE OF FRICTION. |       |       |      |      |      |
|----------------------------------|-------------------------|--------------------|-------|-------|------|------|------|
| Angle $i$ .                      | Vertical to Horizontal. | 20°                | 25°   | 30°   | 35°  | 40°  | 45°  |
| 33° 40'                          | 1 to 1½                 | .....              | ..... | ..... | 0.59 | 0.36 | 0.26 |
| 29° 45'                          | 1 to 1¾                 | .....              | ..... | 0.76  | 0.45 | 0.32 | 0.23 |
| 26° 30'                          | 1 to 2                  | .....              | ..... | 0.54  | 0.39 | 0.29 | 0.21 |
| 21° 50'                          | 1 to 2½                 | .....              | 0.60  | 0.45  | 0.34 | 0.27 | 0.20 |
| 18° 30'                          | 1 to 3                  | 0.72               | 0.52  | 0.40  | 0.31 | 0.24 | 0.19 |
| 14° 00'                          | 1 to 4                  | 0.59               | 0.45  | 0.36  | 0.29 | 0.23 | 0.18 |
| 0° 00'                           | Level                   | 0.50               | 0.40  | 0.33  | 0.27 | 0.22 | 0.18 |

*Angle of Friction.*—In order to be able to apply any of the formulas for determining earth pressures, it is necessary to know the weight per unit volume and the angle of friction of the earth. These vary with the kind of material to be filled behind the wall and its condition as to compactness and moisture.

The natural slope for the earth is the slope at which the surface of the material will stand when dumped into piles, the frictional resistance keeping the surface layer from sliding or rolling down the slope. The angle of sliding friction of a wedge of earth upon an earth surface may not be the same as the inclination of the natural slope. Values of sliding friction as determined by experiment vary considerably for the same material, and it is possible that much of the variation is due to the methods of testing rather than to differences in the materials. The natural slope of a particular material may usually be approximately determined without difficulty and its use instead of the angle of sliding friction would ordinarily be safe. Table XIX gives approximate values of the angle of internal friction, the natural slopes and weights of various materials commonly met in construction.

TABLE XIX.—FRICTION ANGLES AND WEIGHTS OF MATERIALS

| Kind of Material.    | Angle of Friction. | Natural Slope, Horizontal to Vertical. | Weight per Cubic Foot. |
|----------------------|--------------------|--|------------------------|
| Clay, dry.....       | 35°                | 1.5 to 1                               | 110                    |
| Clay, damp.....      | 40°                | 1.2 to 1                               | 110                    |
| Clay, wet.....       | 20°                | 3.0 to 1                               | 120                    |
| Sand, dry.....       | 35°                | 1.5 to 1                               | 100                    |
| Sand, moist.....     | 40°                | 1.3 to 1                               | 100                    |
| Sand, wet.....       | 25°                | 2.0 to 1                               | 115                    |
| Gravel and sand..... | 40°                | 1.5 to 1                               | 110                    |
| Broken rock.....     | 45°                | 1.2 to 1                               | 110                    |

*Surcharged Walls.*—The formulas for earth pressure already given assume the earth to carry only its own weight and the upper surface to slope from the top of the wall. When the earth behind the wall carries a load upon its surface, as when supporting a railway track or a pile of material of any sort, the pressure against the wall is increased uniformly over its entire depth.

If  $w$  is the weight of the load per unit area of earth surface, Formula (1) becomes,

$$P = \left( \frac{eh^2}{2} + wh \right) Q \dots \dots \dots (3)$$

The point of application of  $P$  is at a distance

$$\frac{l}{3} \cdot \frac{eh + 3w}{eh + 2w} h,$$

above the base of the wall.

In the same manner for the pressure on a vertical section through the mass of earth, Formula (2) becomes

$$E = \left( \frac{eS^2}{2} + wS \right) K \dots \dots \dots (4)$$

and its point of application is at a distance

$$\frac{l}{3} \cdot \frac{eS + 3w}{eS + 2w} S.$$

**125. Graphical Method.**—When the surface of earth is irregular or broken, the formulas do not apply, although it is usually possible to approximate the plane surfaces with sufficient accuracy. Graphical determination of earth pressures may be made when the slope of the surface is not too great. When the surface slope is near the natural slope for the material, these methods cannot be used.

A graphical method is shown in Fig. 63.  $OA$  is the back of a wall, and  $ABCD$ , etc., the upper surface of the earth resting against it. Divide the earth into a number of prisms by the lines  $OB$ ,  $OC$ , etc. On the line  $oa$  lay off on some convenient scale  $ab$ ,  $bc$ , etc., equal respectively to the weights of the prisms  $OAB$ ,  $OBC$ ,  $OCD$ , etc.

From  $a$  draw the lines  $ab_1$ ,  $ac_1$ , etc., making the angle of friction ( $\phi$ ) with the normals to  $OB$ ,  $OC$ ,  $OD$ , etc., respectively. From the points  $b$ ,  $c$ ,  $d$ , etc., draw the lines  $bb_1$ ,  $cc_1$ ,  $dd_1$ , etc., making the angle of friction ( $\phi$ ) with the back of the wall ( $OA$ ), to intersection with the lines  $ab_1$ ,  $ac_1$ , etc., respectively. The lengths  $bb_1$ ,  $cc_1$ ,  $dd_1$ , etc., will then represent, on the scale to which the weights were laid off, the thrusts of the prisms between the back of the wall and the planes  $OB$ ,  $OC$ , etc., respectively.

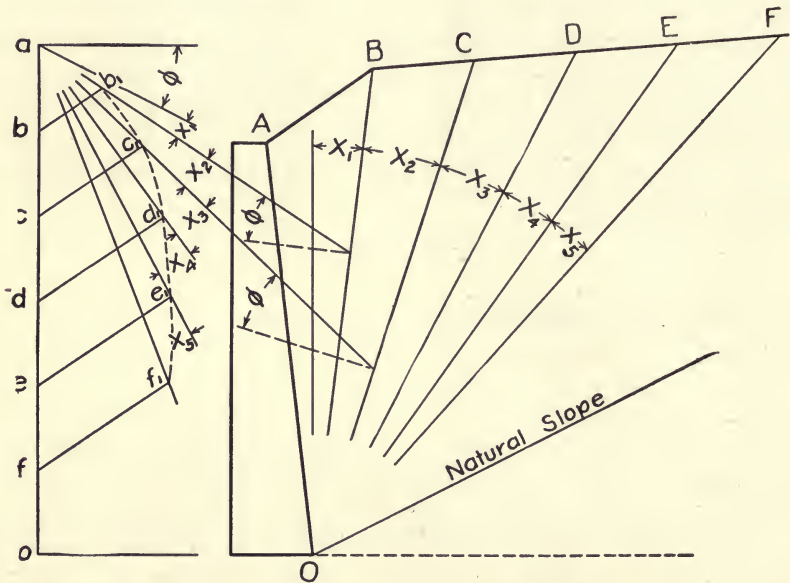

FIG. 63.—Graphical Determination of Earth Pressures.

In the figure,  $ee_1$  is the maximum thrust, caused by the prism between  $OA$  and  $OE$ , showing  $OE$  to be the plane of rupture. This resultant thrust will act at a distance  $h/3$  from the base of the wall, at the angle of friction with the normal to the wall.

Detailed discussions of methods of determining earth pressures are given in "Retaining Walls for Earth" by M. A. Howe, New York, 1896, and in "Practical Designing of Retaining Walls," by Wm. Cain, New York, 1914. An interesting paper by E. P. Goodrich in Trans-



actions, American Society of Civil Engineers, December, 1904, gives results of experiments for determination of internal friction and lateral pressure of earth.

#### ART. 34. SOLID MASONRY WALLS

**126. Stability of Walls.**—A masonry retaining wall may fail in either of three ways:

1. By overturning or rotating about its toe.
2. By crushing the masonry.
3. By sliding on a horizontal joint.

Insufficient foundation is probably the most common cause of failure of retaining walls. This is not, however, due to failure of the wall itself, but to lack of sufficient footing or other support when placed upon compressible or soft soils or to lack of proper drainage. This is discussed in Art. 36.

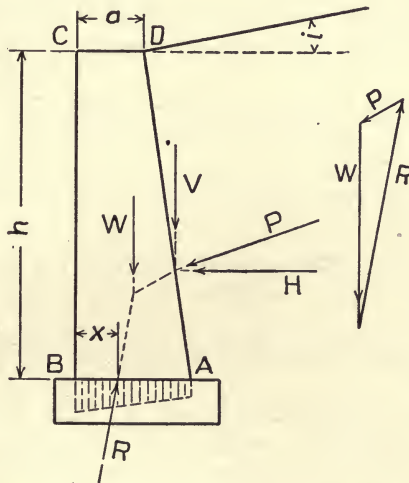

FIG. 64.—Stresses upon Retaining Walls.

In Fig. 64,  $ABCD$  is a wall with vertical face supporting a bank of earth as shown.

- Let  $P$  = thrust of earth against the wall;  
 $V$  = Vertical component of  $P$ ;  
 $H$  = horizontal component of  $P$ ;  
 $W$  = weight of wall acting through its center of gravity;  
 $R$  = resultant pressure on base  $AB$ ;

- $b$  = width of base of wall;
- $a$  = width of top of wall;
- $d$  = distance from face of wall to its center of gravity;
- $f_c$  = unit compression on masonry at toe of wall;
- $x$  = distance from toe of wall to point of application of resultant pressure upon the base;
- $\beta$  = angle made by  $R$  with base of wall.

*Resisting Moment.*—The moment of the thrust about the toe of the wall at  $B$  is  $M_p = H \times \frac{h}{3} - V \times \frac{(2b+a)}{3}$ .

This moment tends to overturn the wall by causing rotation about  $B$ , and is resisted by the moment of the weight of wall in the opposite direction. This moment is  $M_w = Wd$ .

When these moments are equal ( $M_w - M_p = 0$ ), the resultant  $R$  obtained by combining  $P$  and  $W$  passes through  $B$  and the wall is on the point of overturning. The ratio  $M_w/M_p$  is the factor of safety against overturning.

When  $M_w$  is greater than  $M_p$ ,  $R$  will cut the base of the wall to the right of  $B$ . Placing  $M_r = M_w - M_p$  we have

$$(W - V)x = Wd - \frac{Hh}{3} + \frac{V(2b+a)}{3},$$

from which we find the distance of the point of application of  $R$  from  $B$ :

$$x = \frac{3Wd + V(2b+a) - Hh}{3(W+V)}. \dots \dots \dots (5)$$

This point of application of  $R$  may also be found graphically as shown in Fig. 63.

The resultant  $R$  should always cut the base of the wall within its middle third ( $x > b/3$ ) in order that the pressure may be distributed over the whole section of the base and there may be no tendency for the joint to open, or no tensile stress developed at the inner edge ( $A$ ) of the section.

*Crushing of Masonry.*—The unit stress at the toe of the wall ( $B$ ) must not exceed the safe crushing strength of the masonry. The distribution of stress over the section depends upon the position of the point of application of the resultant ( $R$ ). When  $x = b/3$ , the stress at  $A$  will be zero, and the stress at  $B$ ,  $f_c = \frac{2(W+V)}{b}$ . If  $x$  be less than  $b/3$ , the pressure will be distributed over a distance  $3x$

from the toe (*B*), and the maximum stress,  $f_c = \frac{2(W+V)}{3x}$ . When *x* is greater than  $b/3$  the maximum compression,

$$f_c = \frac{(W+V)(4b-6x)}{b^2} \dots \dots \dots (6)$$

*Resistance to Sliding* depends upon the development of sufficient friction in any joint through the wall to overcome the pressure parallel to the joint. Thus (Fig. 64) in order that no sliding occur at the base of the wall, the frictional resistance in the joint *AB* must be greater than the horizontal component of the thrust *R*. This will be the case when *R* makes an angle ( $\beta$ ) with the normal to *AB* that is less than the angle of friction of masonry sliding upon masonry.

$\tan \beta = \frac{H}{W+V}$ , must be less than the coefficient of friction of the masonry.

In the construction of heavy walls, resistance to sliding may be increased by breaking joints so that no continuous joint exists through the wall. Joints inclined from the front to the back of the wall are also sometimes used so as to bring the resultant pressure more nearly normal to the joint.

**127. Empirical Design.**—In the practical designing of retaining walls, engineers have commonly used empirical rules given by certain prominent authorities, or have assumed dimensions based upon their own experiences. The uncertain and conflicting nature of the assumptions used in producing the formulas based upon the various theories, and the lack of satisfactory experimental data has caused the use of dimensions shown by experience to be safe and in very many instances probably quite excessive.

*Trautwine's rules* have been extensively used for many years, and are as follows <sup>1</sup> for vertical walls:

- When the backing is deposited loosely, as usual, as when dumped from carts, cars, etc.,
- Wall of cut stone, or first-class large ranged rubble, in mortar . . . . . .35 of its entire vertical height
- Wall of good common scabbled mortar-rubble, or brick . . . . . .4 of its entire vertical height
- Wall of well-scabbled dry rubble . . . . . .5 of its entire vertical height

With good masonry, however, we may take the height from the ground surface up, instead of the total height as above indicated.

When the wall has a sloping or offset back, the thickness above

<sup>1</sup> Trautwine's Engineer's Pocket-Book.



given may be used as the mean thickness, or thickness at the mid-height.

*Baker's Rules.*—Sir Benjamin Baker, from an extended experience in the construction of walls under many differing conditions, and after numerous experiments upon the thrust of earth, gives<sup>1</sup> the following statement of his views upon the design of retaining walls:

Experience has shown that a wall one-quarter of the height in thickness, and battering 1 inch or 2 inches per foot on the face, possesses sufficient stability when the backing and foundation are both favorable. The Author, however, would not seek to justify this proportion by assuming the slope of repose to be about 1 to 1, when it is perhaps more nearly  $1\frac{1}{2}$  to 1, and a factor of safety to be unnecessary, but would rather say that experiment has shown the actual lateral thrust of good filling to be equivalent to that of a fluid weighing about 10 pounds per cubic foot, and allowing for variations in the ground, vibrations, and contingencies, a factor of safety of 2, the wall should be able to sustain at least 20 pounds fluid pressure, which will be the case if one-quarter of the height in thickness.

It has been similarly proved by experience that under no ordinary conditions of surcharge or heavy backing is it necessary to make a retaining wall on a solid foundation more than double the above, or one-half of the height in thickness. Within these limits the engineer must vary the strength in accordance with the conditions affecting the particular case.

The rules of Sir Benjamin Baker give walls considerably lighter than those of Trautwine, and the tendency in recent practice has been to somewhat reduce the thicknesses for walls backed with good materials and built under favorable conditions. Where from lack of drainage or other cause, the backing is liable to get into soft condition, it may be necessary to considerably increase thickness.

**128. Using Formulas in Design.**—The design of a wall to sustain a bank of earth is a comparatively simple matter once the earth pressure has been determined. The difficulties met are those of judging the character of the material and its probable pressure against the wall. It is probable that in most instances the full pressures that theoretically might come upon the wall are not actually developed. The design should be made for the worst conditions which may reasonably be expected to occur, but the construction of heavy walls to provide for bad conditions which are not likely to occur, and which may be met by proper attention to drainage and proper care in placing the backing, is unnecessarily expensive and wasteful.

For walls with vertical or nearly vertical backs, Poncelet's formulas, taking into account the friction of the earth on the back of

<sup>1</sup> The Actual Lateral Pressure of Earth, Van Nostrand Science Series, and Proceedings, Institution of Civil Engineers, Vol. LXV, p. 183.

the wall, give thicknesses for walls which agree fairly well with the results of experience and not differing greatly from the rules suggested by Sir Benjamin Baker.

In designing by this method, the pressure of earth is obtained by the use of Formula (1), or from Table XVII, a section of wall is assumed and its sufficiency investigated.

*Example 1.*—A masonry wall, 22 feet high, is to support a bank of earth whose surface has an upward slope of 1 to 3 from the top of the wall. The backing is ordinary earth whose friction angle may be taken at  $35^\circ$ . Weight of masonry is 150 pounds and of earth 100 pounds per cubic foot. Find proper section for the wall.

*Solution.*—Try a rectangular wall with thickness of 7.5 feet. From Table XVII, we find  $Q = .33$ . Then

$$P = \frac{eh^2}{2} Q = \frac{100 \times 22 \times 22 \times .33}{2} = 7986 \text{ pounds per foot of length of wall.}$$

As  $P$  makes angle of  $35^\circ$  with normal to back of wall,

$$H = P \cos 35^\circ = 6770 \text{ pounds and } V = P \sin 35^\circ = 4580 \text{ pounds.}$$

$$W = 22 \times 7.5 \times 150 = 24,750 \text{ pounds.}$$

From (5), we find

$$x = \frac{3 \times 24750 \times 3.75 + 4580 \times 3 \times 7.5 - 6770 \times 22}{3(24750 + 4580)} = 2.64$$

and the resultant ( $R$ ) comes just within the middle third of the base.

The crushing stress on the masonry at the toe of the wall is (6)

$$f_c = \frac{(W + V)(4b - 6x)}{b^2} = \frac{(24750 + 4580)(4 \times 7.5 - 6 \times 2.64)}{7.5 \times 7.5} = 7383 \text{ lb./ft.}^2$$

which would be quite safe for any ordinary masonry.

$$\tan \beta = \frac{H}{W - V} = \frac{6770}{24750 - 4580} = .231, \text{ or } \beta = 13^\circ,$$

and sliding could not occur.

*Battered Face.*—The face of the wall may be battered, so as to diminish the width at top by one-third, using the same width of base without decreasing its stability.

*Battered Back.*—A wall with battered back may be used. Assume a top thickness,  $a = 5.5$ , and base thickness,  $b = 9.5$ . The angle made by the back of the wall with the horizontal  $\theta = 100^\circ 20'$ . From Table XVII, we find  $Q = .47$ , then  $P = \frac{eh^2 Q}{2} = \frac{100 \times 22 \times 22 \times 47}{2}$

= 11624 pounds.  $H = P \cos (\theta + \phi - 90) = 8170$  pounds, and  $V = P \sin (\theta + \phi - 90^\circ) = 8270$  pounds.  $W = \frac{5.5 + 9.5}{2} \times 22 \times 150 = 24750$  pounds.

From (3),

$$x = \frac{3 \times 24750 \times 3.83 + 8270(2 \times 9.5 + 5.5) - 8170 \times 22}{3(24750 + 8270)} = 3.11 \text{ ft.}$$

$R$  cuts the base practically at one-third its width from the toe.

The crushing stress at the toe is  $f_c = \frac{2(W+V)}{b} = 6950$  pounds, a little less than for the rectangular wall.

$\tan \beta = \frac{8170}{24750 + 8270} = .247$ , within safe limits but somewhat more than for the rectangular wall.

*Example 2.*—A retaining wall 20 feet high is to support a horizontal bank of earth carrying a railway track. If the maximum train load is taken at 800 pounds per square foot of surface, and the angle of friction of the earth at  $30^\circ$ , find the thickness of wall required by Poncelet's formula.  $w = 150$  pounds and  $e = 100$  pounds per cubic foot.

*Solution.*—Assume a thickness of wall of 9 feet. From Table XVII, we have  $Q = 30$ . Then (3)

$$P = \left( \frac{eh^2}{2} + wh \right) Q = \left( \frac{100 \times 400}{2} + 800 \times 20 \right) .30 = 10800 \text{ pounds}$$

and  $H = P \cos \phi = 10800 \times .866 = 9350$  pounds,

$$V = 10800 \times .5 = 5400 \text{ pounds.}$$

$$W = 9 \times 20 \times 150 = 27000 \text{ pounds.}$$

Using (5),

$$x = \frac{3 \times 27000 \times 4.5 + 5400 \times 9 \times 3 - 9350 \times 20}{3(27000 + 5400)} = 3.73 \text{ ft.}$$

The resultant thrust cuts the base within the middle third, and a little less width might answer.

The crushing stress at the toe of the wall is

$$f_c = \frac{(W+V)(4b-6x)}{b^2} = 5600 \text{ pounds.}$$

*The minimum thickness* allowable for a solid wall is that which causes the resultant thrust ( $R$ ) to cut the base at a distance  $x = l/3$  from the toe of the wall. For a rectangular wall, the width bears a direct ratio to the height for any particular values for weights of



materials and angles of friction. Table XX gives minimum values of thickness ratio, by Poncelet's formula for walls in which the weight of masonry is taken as 150 lb./ft.<sup>3</sup> and the weight of earth as 100 lb./ft.<sup>3</sup>

TABLE XX.—MINIMUM THICKNESS OF WALLS BY PONCELET'S FORMULA

Values of  $b/h$ , when  $w=150$  lb./ft.<sup>3</sup> and  $e=100$  lb./ft.<sup>3</sup>

| Slopes of Earth Surface Vertical to Horizontal. | ANGLES OF FRICTION. |      |      |      |      |      |
|---|---------------------|------|------|------|------|------|
|   | 20°                 | 25°  | 30°  | 35°  | 40°  | 45°  |
| 1 to 1½   | ....                | .... | .... | 0.39 | 0.31 | 0.25 |
| 1 to 1¾   | ....                | .... | 0.46 | 0.35 | 0.29 | 0.24 |
| 1 to 2  | ....                | .... | 0.41 | 0.34 | 0.28 | 0.23 |
| 1 to 2½   | ....                | 0.46 | 0.39 | 0.33 | 0.27 | 0.23 |
| 1 to 3  | 0.53                | 0.43 | 0.37 | 0.32 | 0.27 | 0.23 |
| 1 to 4  | 0.49                | 0.41 | 0.35 | 0.30 | 0.26 | 0.22 |
| Level   | 0.43                | 0.38 | 0.33 | 0.29 | 0.25 | 0.22 |

For walls battered or stepped on the back the minimum thickness given in the table may be used as the average thickness at the middle of the height. This gives a broader base to the wall and gives a larger factor of safety against overturning, but requires the same volume of masonry to keep the resultant thrust within the middle third of the base.

Walls computed as rectangular may be battered on the face to an extent which lessens the top thickness by one-third without increasing the base thickness. This slightly decreases the resisting moment, but increases the value of  $x$ , lessens the pressure at the toe, and does not impair the stability of the wall.

ART. 35. REINFORCED CONCRETE WALLS

129. Types of Reinforced Concrete Retaining Walls.—There are two types of reinforced concrete retaining walls in common use:

1. The cantilever type and 2, the counterforted type.

Both of these depend upon the weight of earth carried by the base of the wall to prevent overturning. They differ in the way in which the face wall is attached to the base.

A cantilever wall is shown in Fig. 65, consisting of a vertical stem attached to a base,  $ACFB$ . The weight of the mass of earth  $BFEG$ , rests upon the base of the wall  $BF$  and serves to assist the wall in resisting the overturning moment of the earth thrust. The hori-

zontal pressure of earth on  $EF$  is carried by the vertical stem  $CDEF$  acting as a cantilever beam. The projecting bases  $FB$  and  $AC$  are also cantilever beams, the one supporting the weight of earth resting upon it, the other resisting the upward thrust of the foundation at the toe of the wall.

A counterforted wall is shown in Fig. 66. The face wall  $CDEF$  is connected with the base  $ACFB$  by narrow counterforts  $EFB$ , spaced several feet apart. The counterforts are cantilever beams, each carrying the horizontal earth thrust on the face wall  $EF$  for a panel length of wall. The face walls  $CDEF$  are slabs holding the earth pressure between counterforts and transferring the pressure

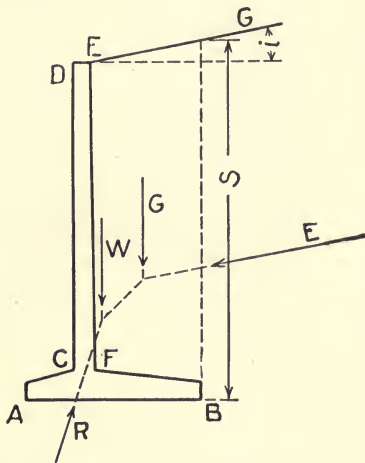

FIG. 65.—Cantilever Wall.

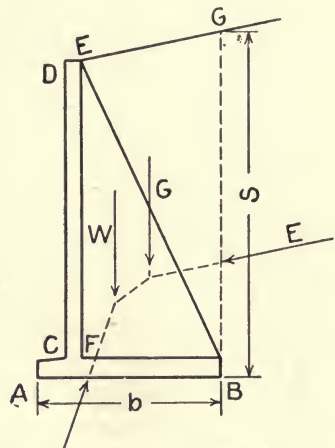

FIG. 66.—Counterfort Walls.

to the counterforts. The base  $FB$  is a slab carrying the weight of earth  $FEGB$  between counterforts and holding down the ends of the counterforts. The base  $AC$  at the front of the wall is a cantilever carrying the upward thrust of the foundation at the toe of the wall.

The cantilever type is commonly used for moderate heights of wall. For walls more than 20 or 25 feet high, the counterforted wall is usually more economical. The quantities of materials required for a counterforted wall are less and the amount of form work more than for a cantilever wall.

**130. Design of Cantilever Wall.**—In designing reinforced concrete walls, the thrust in the vertical section of earth passing through the inner edge of the base may be computed by Rankine's formula, as given in Section 123:

$$E = \frac{eS^2}{2} \cdot \cos i \cdot \frac{\cos i - \sqrt{\cos^2 i - \cos^2 \phi}}{\cos i + \sqrt{\cos^2 i - \cos^2 \phi}} = \frac{eS^2}{2} K \quad \dots \quad (2)$$

Values of  $K$  may be taken from Table XVIII. This thrust is parallel to the upper surface of the earth and its horizontal and vertical components are

$$H = E \cos i = \frac{eS^2}{2} K \cos i, \text{ and } V = E \sin i = \frac{eS^2}{2} K \sin i.$$

The method of design will be illustrated by numerical examples.

*Example 3.*—Design a retaining wall to hold a level bank of earth 16 feet high. The base of footing is to be 3 feet below surface of ground and the pressure on the soil is limited to 4000 lb./ft.<sup>2</sup> The backing is ordinary soil with angle of friction of 35°. Earth weighs 100 pounds and concrete 150 pounds per cubic foot. Unit stresses will be based upon use of 2000 pounds concrete and plain bars of medium steel.

*Solution.*—Assume the base under the wall 12 inches thick. The height of the wall above the base is then 18 feet, and the horizontal thrust, taking  $K$  from Table XVIII,

$$E = \frac{eS^2 K}{2} = \frac{100 \times 18 \times 18 \times 27}{2} = 4374 \text{ pounds per foot of length of wall.}$$

The bending moment caused by this thrust upon the section at the top of the base is  $M = 4374 \times 6 \times 12 = 314928$  in.-lb.

From Table VII, for

$$f_c = 650 \text{ and } f_s = 16,000, \text{ we find } R = 108 \text{ and } p = .0078.$$

Then

$$Rbd^2 = M \text{ becomes } 108 \times 12d^2 = 314928, \text{ and } d = 15.5 \text{ inches.}$$

Assuming the steel to be embedded 1.5 inches in the concrete, the total thickness of the vertical stem at the top of the base will be 17 inches.

The steel area required for a length of 12 inches of wall is

$$pbd = .0078 \times 12 \times 15.5 = 1.45 \text{ in.}^2$$

From Table XV we find that  $\frac{7}{8}$ -inch bars spaced 5 inches apart will answer the purpose.

If we assume 10 inches to be the minimum allowable thickness at the top of the wall and make the faces of the wall plane surfaces, the thickness at all intermediate points will be greater than required for strength. At a point 12 feet below the top, the bending moment



is  $314928 \times 8/27 = 93312$  in.-lb., and the effective depth of beam is 13 inches. Then

$$R = \frac{93312}{12 \times 13 \times 13} = 46. \quad R/f_s = 46/16000 = .0029,$$

and from Table IX, we find  $p = .0032$ . The area of steel required is  $12 \times 13 \times .0032 = 0.5$  in.<sup>2</sup> per foot of length, or about one-third of that at the base. Similarly at a section 6 feet below the top, no steel would theoretically be required.

If all of the bars be carried up 6 feet, every third bar 12 feet and every sixth bar to the top the reinforcement will be amply strong. The lower ends of these bars should be turned up in the base for anchorage.

The maximum shear in section at base is 4374 pounds, and

$$v = \frac{V}{bjd} = \frac{4374}{12 \times .874 \times 15.5} = 27 \text{ lb./in.}^2$$

No diagonal tension reinforcement is necessary.

*Overturning Moment.*—Assume the width of base at about 45 per cent of the total height, or 8.5 feet. Let the inner surface of the vertical stem be vertical, and place the stem at a distance equal to one-third the width of base ( $b/3$ ) from the toe of the wall. (See Fig. 67.)

The moment of the thrust about the toe at  $A$  tends to overturn the wall, while the moments of the weights of the wall and earth resting upon it resist overturning.

The weight of the vertical stem is

$$W_1 = \frac{10+17}{12 \times 2} (18 \times 150) = 3035 \text{ pounds.}$$

The weight of the base is  $W_2 = 1.0 \times 8.5 \times 150 = 1275$  pounds.

The weight of the earth is  $G = 18 \times 4.25 \times 100 = 7650$  pounds.

The earth thrust,  $E = \frac{eS^2K}{2} = \frac{100 \times 19 \times 19 \times .27}{2} = 4873$  pounds.

The moment on the toe at  $A$  is

$M = 3035 \times 3.65 + 1275 \times 4.25 + 7650 \times 6.4 - 4873 \times 6.33 = 34610$  ft.-lb. The point of application of the resultant on the foundation soil is equal to the moment about  $A$  divided by the vertical component of the resultant, or

$$x = \frac{34610}{3035 + 1275 + 7650} = 2.89 \text{ feet.}$$

This brings the resultant within the middle third of the base.

The factor of safety against overturning is

$$\frac{3035 \times 3.65 + 1275 \times 4.25 + 7650 \times 6.4}{4873 \times 6.33} = 2.12.$$

*Pressure on Foundation.*—The total vertical load on the foundation is  $3035 + 1275 + 7650 = 11,960$  pounds. The pressure at the

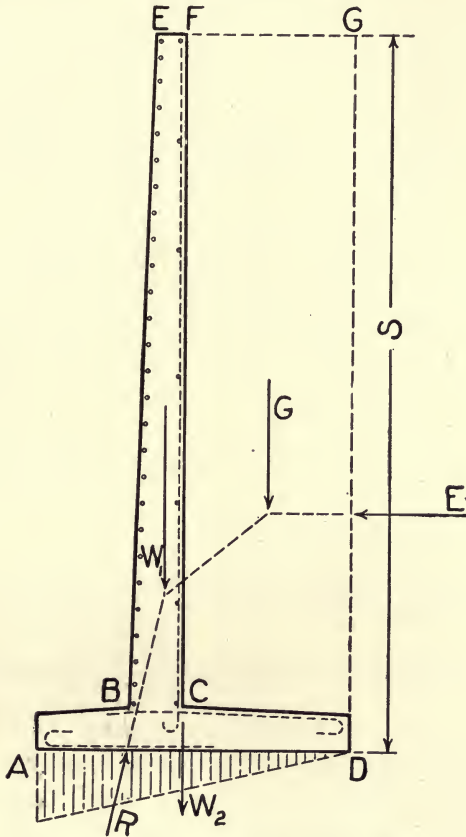

FIG. 67.—Design of Cantilever Wall.

toe is twice the average pressure,  $2 \times 11960 / 8.5 = 2814$  lb./ft.<sup>2</sup>, which is within safe limits.

*Inner Base Cantilever.*—The length of the inner cantilever is 4.25 feet. It is subject to the action of three loads:

- (1) The weight of the earth resting upon it (1800 pounds per linear foot);
- (2) Weight of the cantilever itself (150 pounds per linear foot).

- (3) Upward pressure of the foundation soil (which is 0 at the end  $D$  and 1400 pounds where the cantilever joins the vertical wall at  $C$ ).

The bending moment on the section at  $C$  is

$$M = 1800 \times 4.25 \times \frac{4.25}{2} + 150 \times 4.25 \times \frac{4.25}{2} - \frac{1400 \times 4.25}{2} \times \frac{4.25}{3}$$

$$= 13,396 \text{ ft.-lb. or } 160,752 \text{ in.-lb.}$$

From Table VII,  $R = 108$  and  $p = .0078$ . Then

$$108 \times 12d^2 = 160752 \text{ and } d = 11.2 \text{ inches.}$$

If the steel be placed 1.75 inches below the top surface the thickness at  $C$  is 13 inches,

$$A = pbd = .0078 \times 11.2 \times 12 = 1.05 \text{ in.}^2$$

From Table XV, we find that  $\frac{3}{4}$ -inch bars spaced 5 inches apart, the same as the vertical reinforcement will answer the purpose. These bars should be anchored by bending or by continuing them through the concrete on the front of the base to a length of at least 50 diameters (37.5 inches).

The shear in section at  $C$  is

$$V = 1800 \times 4.25 + 150 \times 4.25 - 1400 \times 4.25/2 = 5312 \text{ pounds,}$$

and 
$$v = \frac{V}{bjd} = \frac{5312}{12 \times .874 \times 11.2} = 45 \text{ lb./in.}^2$$

This value is rather large for use without diagonal tension reinforcement. If we make

$$v = 40 \text{ lb./in.}^2 \quad d = \frac{V}{bjd} = \frac{5312}{12 \times .874 \times 40} = 12.6 \text{ in.}$$

Using  $d = 13$  inches and embedding the steel 2 inches in the concrete, the total depth of base at  $C$  becomes 15 inches.

*Outer Base Cantilever.*—The length of the outer cantilever is 2.83 feet. The forces acting upon it are its own weight acting downward, and the thrust of the foundation soil acting upward (2814 lb./ft.<sup>2</sup> at  $A$  and 1876 lb./ft.<sup>2</sup> at  $B$ ). The shear in section at  $B$  is

$$V = \frac{2814 + 1876}{2} \times 2.83 - 150 \times 2.83 = 6212 \text{ lb.}$$

If the unit shear be limited to 40 lb./in.<sup>2</sup>,

$$d = \frac{V}{bjd} = \frac{6212}{12 \times .874 \times 40} = 14.8 \text{ in.}$$

Making  $d = 15$  inches, the total depth of base at  $B$  is 17 inches.



The bending moment at *B* is

$$M = 1876 \times 2.83 \times \frac{2.83}{2} + \frac{2814 - 1876}{2} \times 2.83 \times \frac{2 \times 2.83}{3} = 12510 \text{ ft.-lb.}$$

or 150,120 in./lb.

$$R = \frac{M}{bd^2} = \frac{150120}{12 \times 12 \times 15} = 55.6,$$

$$R/f_s = 55.6/16000 = .0035.$$

From Table IX,  $p = .0038$ , and  $A = .0038 \times 12 \times 15 = .68 \text{ in.}^2$  per foot of length of wall.

From Table XV,  $\frac{5}{8}$ -inch bars will answer if spaced like the other reinforcement 5 inches apart. These bars must extend into the base a distance of at least 50 diameters (31 inches) past the section at *B*.

Horizontal bars should be placed longitudinally through the wall near the exposed face to prevent cracking due to contraction;  $\frac{1}{2}$ -inch bars spaced 12 inches apart are sufficient for this purpose.

*Example 4.*—A cantilever wall is to be 17 feet high above ground and to support a bank of earth whose surface has an upward slope of 2 horizontal to 1 vertical from the top of the wall. Angle of friction for backing earth  $\phi = 35^\circ$ . The soil under the base may be safely loaded with 6000 pounds per square foot. Earth filling weighs 100 lb./ft.<sup>3</sup> and concrete 150 lb./ft.<sup>3</sup> Safe values of  $f_c = 500 \text{ lb./in.}^2$   $f_s = 16,000 \text{ lb./in.}^2$ , and for diagonal tension  $v = 30 \text{ lb./in.}^2$   $n = 15$ . The base of the wall will extend 4 feet below the surface of the ground and the toe of the wall cannot extend beyond its face.

*Solution.*—Assume a depth of base of 24 inches and a width of base of 12 feet. (See Fig. 68.)

*Vertical Wall.*—The total height of the vertical wall is 19 feet. The thrust on the back of this wall is

$$E = \frac{eh^2K}{2} = \frac{100 \times 19 \times 19 \times .39}{2} = 7040 \text{ pounds.}$$

This acts parallel to the surface of the earth and its horizontal component  $H = 7040 \cos 26^\circ 30' = 6300$  pounds. The moment of this about the base of the wall is  $(6300 \times 19/3) \times 12 = 478,800 \text{ in.-lb.}$  From Table VII,  $R = 72$  and  $p = .005$ .  $12d^2 = 478800/72 = 6648$ , and  $d = 24$  inches.

The total thickness at base is 26 inches. Take top as 12 inches thick, and make face of wall vertical. At base,  $A = 24 \times 12 \times .005 = 1.44 \text{ in.}^2$  From Table XV,  $\frac{3}{4}$ -inch square bars  $4\frac{1}{2}$  inches apart will answer. All bars will extend to 12 feet below top, every third bar to 6 feet below top and every sixth bar to top of wall.

Shear at base section is 6300 pounds and

$$v = \frac{6300}{12 \times .9 \times 24} = 25 \text{ lb./in.}^2$$

which is within limits without diagonal tension reinforcement.

*Overturing Moment.*—The thrust on the vertical section at the inner edge of the base is

$$E = \frac{eS^2}{2} K = \frac{100 \times 26.5 \times 26.5}{2} \times .39 = 13,690 \text{ pounds.}$$

Its horizontal component is

$$H = 13,690 \cos 26^\circ 30' = 12,250 \text{ pounds}$$

and its vertical component

$$V = 13,690 \sin 26^\circ 30' = 6100 \text{ pounds.}$$

The weight of the base of wall

$$W_1 = 12 \times 2 \times 150 = 3600 \text{ pounds.}$$

Weight of vertical wall

$$W_2 = \frac{1-2.2}{2} \times 19 \times 150 = 4560 \text{ pounds.}$$

Weight of earth on wall

$$G = \left( \frac{9.8+11}{2} \times 19 + \frac{11 \times 5.5}{2} \right) \times 100 = 22785 \text{ pounds.}$$

The moment of  $E$  about the toe of the wall is

$$M_0 = 12250 \times 26.5/3 - 6100 \times 12 = 35000 \text{ ft.-lb.}$$

The moment of resistance is

$$M_r = 3600 \times 6 + 4560 \times .64 + 22785 \times 7.0 = 184000 \text{ ft.-lb.}$$

The factor of safety against overturning is  $184000/35000 = 5.2$ .

The distance from toe to point of application of resultant pressure on foundation

$$x = \frac{184000 - 35000}{3600 + 4560 + 22785 + 6100} = 4.03 \text{ feet.}$$

The maximum pressure on the soil at the toe of the wall is

$$\left( \frac{3600 + 4560 + 22785 + 6100}{12} \right) 2 = 6175 \text{ lb./ft.}^2$$

*Base Cantilever.*—The weight of earth resting upon the inner base is

$$G = \left( 9.8 \times 19.6 + \frac{9.8 \times 4.9}{2} \right) \times 100 = 21610 \text{ pounds.}$$

The weight of the base is  $9.8 \times 2 \times 150 = 2940$  pounds. The upward thrust of the soil is

$$\frac{5055}{2} \times 9.8 = 24770 \text{ pounds.}$$

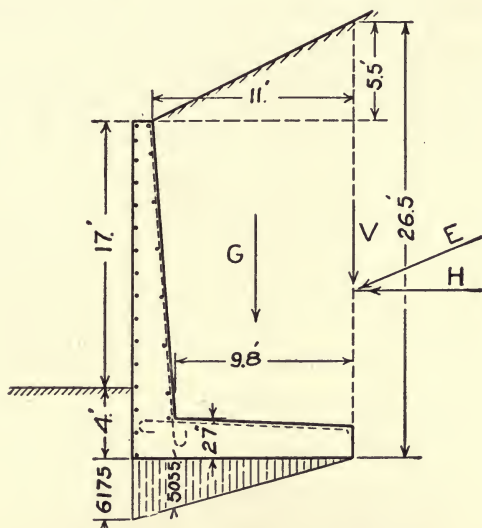

FIG. 68.—Cantilever Wall.

The maximum bending moment at junction with vertical wall is

$$M = \left( 21610 \times 5.1 + 2940 \times 4.9 - 24770 \times \frac{9.8}{3} \right) \times 12 = 524,000 \text{ in.-lb.}$$

$$d = \sqrt{\frac{M}{Rb}} = \frac{524000}{72 \times 12} = 24.6 \text{ inches. Make full depth 27 inches.}$$

$A = 24.6 \times 12 \times .005 = 1.43 \text{ in.}^2$ ;  $\frac{3}{4}$ -inch square bars spaced  $4\frac{1}{2}$  inches apart as in vertical wall meet the requirement.

For this loading, the point of maximum shear occurs where the intensity of the downward forces equals that of the upward forces. This occurs at a point distant

$$\frac{5055 - (1960 + 300)}{516 + 50} = 4.94 \text{ feet}$$



from the back of the vertical wall. The shear at this point is

$$V = \left( \frac{24.5 + 22.0}{2} \right) \times 4.86 \times 100 + 2 \times 4.86 \times 150 - \frac{2508}{2}$$

$$\times 4.86 = 6663 \text{ pounds}$$

and

$$v = \frac{V}{bjd} = \frac{6663}{12 \times .9 \times 25} = 25 \text{ lb./in.}^2$$

The reinforcing bars must be anchored and longitudinal bars introduced to prevent cracking as in Example 3.

**131. Design of Counterforted Walls.**—In walls of the counterforted type, the vertical curtain wall (See Fig. 69) is a slab supported against the horizontal thrust of the earth by the counterforts at frequent intervals. The counterforts are cantilever beams held in place by the base, and each carrying a panel load of the thrust against the vertical slab. The inner base is a horizontal slab, suspended from the counterforts, and carrying the weight of earth resting upon it. The outer base is a cantilever and carries the upward pressure of the soil upon the toe of the wall as in the cantilever wall.

*Example 5.*—A wall with counterforts is to support a bank of earth 23 feet high, carrying a double track railway as shown in Fig. 69. The base of the wall will extend 4 feet below the surface of the ground, and the soil is capable of carrying a load of 7000 lb./ft.<sup>2</sup> The filling is to be of ordinary earth with  $\phi = 35^\circ$ ,  $e = 100$  lb./ft.<sup>2</sup>, and  $w = 150$  lb./ft.<sup>2</sup>. Maximum allowable stresses are  $f_c = 650$  lb./in.<sup>2</sup>,  $f_s = 16,000$  lb./in.<sup>2</sup>, and  $v = 120$  lb./in.<sup>2</sup>, or without diagonal tension reinforcement  $v = 40$  lb./in.<sup>2</sup>.  $n = 15$ .

*Solution.*—For heavy locomotive loads, the surcharge should be taken as  $L = 1000$  pounds per square foot of surface.

The distance apart of counterforts may vary with different conditions and should be carefully examined in each instance as to its effect upon the cost of the wall. In this problem, we will assume a distance c. to c. of counterforts of 8 feet. Also try a thickness of counterforts of 18 inches.

*Vertical Walls.*—Assuming the base of the wall to be 2 feet thick the height of the curtain wall is  $23 + 4 - 2 = 25$  feet. If we divide the vertical slab into strips each 1 foot high, the horizontal thrust against the bottom strip will be (taking  $K$  from Table XVIII),

$$(eh + L)K = (100 \times 25 + 1000) \cdot 27 = 945 \text{ lb./ft.}^2$$

This strip is then a horizontal beam supported at intervals of 8 feet,

and carrying a uniform load of 945 pounds per linear foot. Considering it to be a partly continuous beam,

$$M = \frac{wl^2}{10} = \frac{945 \times 8 \times 8 \times 12}{10} = 72576 \text{ in.-lb.}$$

$$d^2 = \frac{M}{Rb} = \frac{72576}{108 \times 12} = 56, \quad d = 7.5 \text{ inches.}$$

Make  $d=8$  inches, and the total thickness 10 inches. As 10 inches is about the minimum thickness allowable at the top of the wall, make the thickness the same for the whole slab.

For the bottom strip with  $d=8$  inches,  $R = \frac{72576}{12 \times 8 \times 8} = 95$ ,  
 $R/f_s = 95/16000 = .0059$ , and from Table IX,  $p = .0068$ .

$$A = .0068 \times 12 \times 8 = .65 \text{ in.}^2,$$

and from Table XV we find that  $\frac{5}{8}$ -inch round bars, spaced 5 inches apart will answer.

For a strip 16 feet below the top of the wall,

$$M = \frac{702 \times 8 \times 8 \times 12}{10} = 53914 \text{ in.-lb.}, \quad R = \frac{53914}{12 \times 8 \times 8} = 70,$$

$p = .0049$ ,  $A = .47 \text{ in.}^2$  and the  $\frac{5}{8}$ -inch bars are needed 7 inches apart.

At 8 feet below the top,

$$M = \frac{486 \times 8 \times 8 \times 12}{10} = 31104 \text{ in.-lb.},$$

$R = 49$ ,  $p = .0034$ ,  $A = .33 \text{ in.}^2$  and the  $\frac{5}{8}$ -inch round bars may be spaced 10 inches apart.

We will therefore use  $\frac{5}{8}$ -inch round bars spaced 5 inches apart for the lower 9 feet, 7 inches apart for the next 8 feet and 10 inches apart in the upper 8 feet of the curtain wall. These bars will be run 2 inches from the face of the wall, and negative moments at the counterforts will be taken care of by short rods of the same diameter and spacing extending 24 inches on each side of the mid-section of the counterfort.

The span for shear is the clear distance between counterforts. Assuming the counterfort to be 18 inches thick, the maximum shear is  $V = (4 - 0.75) \times 945 = 3070 \text{ lb./in.}^2$ , and the unit shear

$$v = \frac{3070}{12 \times .874 \times 8} = 37 \text{ lb./in.}^2$$

The 8-inch thickness is therefore sufficient without reinforcement for diagonal tension.

*Resistance to Overturning.*—Assume the width of base at about 50 per cent of the total height or 13.5 feet, and place the middle of the vertical wall over a point one-third the width from the toe. Taking a foot of length of wall between counterforts, the

|                             |   |
|-----------------------------|---|
| weight of certain wall      | = $150 \times 25 \times 10 / 12 = 3125$ pounds, |
| weight of base              | = $150 \times 2 \times 13.5 = 4050$ pounds,     |
| weight of earth             | = $100 \times 25 \times 8.6 = 21500$ pounds,    |
| weight of load upon surface | = $1000 \times 8.6 = 8600$ pounds.              |

Using Rankine's formula,

$$E = \left( \frac{eh^2}{2} + Lh \right) K = \left( \frac{100 \times 27 \times 27}{2} + 1000 \times 27 \right) \times .27 = 17131 \text{ pounds.}$$

The moment of  $E$  about the toe of the wall is

$$M_0 = 17131 \times 9 = 154179 \text{ ft.-lb.,}$$

and the moment of resistance

$$M_r = 3125 \times 4.5 + 4050 \times 6.75 + (21500 + 8600) \times 9.2 = 322919 \text{ ft.-lb.}$$

The factor of safety against overturning is  $322919 / 154179 = 2.09$ . The distance from the toe of the wall to the point of application of the resultant pressure is

$$x = \frac{322919 - 154179}{3125 + 4050 + 30100} = 4.53 \text{ feet,}$$

and is within the middle third of the base.

*Pressure on Soil.*—As the resultant cuts the bottom of the base at one-third the width from the toe, the maximum pressure at the toe is

$$2 \left( \frac{3125 + 4050 + 30100}{13.5} \right) = 5500 \text{ lb./ft.}^2$$

The pressure at the inner edge of the base will be practically nothing.

*Inner Base Slab.*—The loading on the horizontal base slab is the difference between the sum of the weights of earth and of the base acting downward, and the soil pressure acting upward. The maximum load will be at the inner edge, where the upward pressure is a minimum. Taking a foot in width along this edge and neglecting the upward pressure, the load will be  $1000 + 25 \times 100 + 2 \times 150 = 3800$  pounds per linear foot.

The thickness of base slab will probably be determined by requirements for shear. The maximum shear at edge of counterfort (taking



counterforts as 18 inches thick) is  $V = 3800(4 - .75) = 12350$  pounds, and if no reinforcement be used for diagonal shear, the depth

$$d = \frac{V}{bjv} = \frac{12350}{12 \times .874 \times 40} = 30 \text{ inches,}$$

or the full depth must be 32 inches. If the assumed depth of 24 inches be used,

$$v = \frac{12350}{12 \times .874 \times 22} = 53 \text{ lb./in.}^2$$

This would require light reinforcement for diagonal shear for 8 inches from the edge of the counterfort and may be met by bending up a part of the tension reinforcement to use for negative moment over the supports.

The bending moment in the base slab is

$$M = \frac{3800 \times 8 \times 8 \times 12}{10} = 270480 \text{ in.-lb.,}$$

and using the 24-inch depth

$$R = \frac{270480}{12 \times 22 \times 22} = 47.$$

Table VII gives  $p = .0032$ , and  $A = .0032 \times 22 \times 12 = .85 \text{ in.}^2$  From Table XV, we find that  $\frac{3}{4}$ -inch round bars spaced 6 inches apart are needed. The negative moments at the counterforts are the same as the positive moments and may be provided for by bending up alternate bars on each side of the support, and extending these across the counterforts to the quarter points in the next panel.

*Counterforts.*—The counterforts act as cantilevers to carry the horizontal thrust upon the curtain wall for panel lengths of 8 feet. This thrust is

$$8E = 8 \left( \frac{100 \times 25 \times 25}{2} + 800 \times 25 \right) .27 = 110700 \text{ pounds,}$$

and its moment about the section at the top of the base is

$$M = 110700 \times \frac{25}{3} \times 12 = 11070,000 \text{ in.-lb.}$$

Considering the counterfort to act as a T-beam, of which the curtain wall is the flange, and the resultant of the compressive stresses to act at the middle of the base of the curtain wall, we may take this middle point as the center of moments for the tensions in the steel in the back of the counterfort. If the center of gravity

of the steel is 3 inches from the surface of the concrete, its lever arm is 8.1 feet, and the total stress in the steel is

$$= \frac{11070000}{8.1 \times 12} = 114000 \text{ pounds.}$$

The required steel area is  $A = 114000 / 16000 = 7.12 \text{ in.}^2$  From Table X, we find that six  $1\frac{1}{4}$ -inch round bars will answer. These may be placed in two rows, four bars being placed 2 inches and two bars 5 inches from the surface of the concrete. These may be spaced

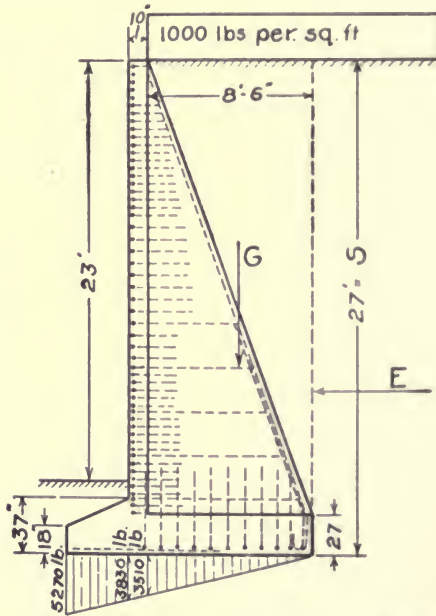

FIG. 69.—Design of Counterforted Wall.

4 inches apart and 3 inches from the sides in a thickness of counterfort of 18 inches.

At a section 16 feet below the top the moment = 4718900 in.-lb., and the steel required

$$A = \frac{4718900}{5.4 \times 12 \times 16000} = 4.54 \text{ in.}^2$$

At 8 feet below the top  $M = 1327100 \text{ in.-lb.}$  and  $A = 2.46 \text{ in.}^2$  Two bars may be stopped at 16 feet below the top, two at 8 feet and the others extend to the top of the counterfort.

The total shear in base section of counterfort is 110,700 pounds, and

$$v = \frac{V}{bjd} = \frac{110700}{18 \times .875 \times (9.4 \times 12)} = 72 \text{ lb./in.}^2$$

At 16 feet below the top  $v = 45 \text{ lb./in.}^2$  Reinforcement for diagonal tension is needed from the base to a little above the section 16 feet below the top. This may be provided by the bars to be used for bonding the counterforts to the curtain walls and base slabs.

*Bonding Bars.*—The curtain wall and the base slab must be tied to the counterforts by horizontal and vertical bars capable of carrying the reactions at the points of support. These will equal the sum of the shears on the two sides of the counterfort. At the bottom of the curtain wall the load per foot of height is  $2(4 - .75)945 = 6140$  pounds and the area of steel required  $6140/16000 = .38 \text{ in.}^2$  If these bars be placed in pairs and at the same distance apart as the horizontal reinforcement in the curtain walls,  $\frac{5}{16}$ -inch round bars will answer. These should be looped around the steel in the face of the curtain wall, and extend into the counterfort at least 50 diameters for bond strength.

For the base slab, the load upon the bonding bars per foot of width  $2(4 - .75)3600 = 23,400$  pounds, and the area of steel required  $A = 23400/16000 = 1.46 \text{ in.}^2$  A pair of  $\frac{5}{8}$ -inch square bars spaced 6 inches apart meets this requirement.

*Base Cantilever.*—The projection of the base at the toe of the wall is a cantilever, as in the cantilever wall, and carries the upward thrust of the soil. The maximum shear is

$$V = \left( \frac{5270 + 3830}{2} \right) \times 3.7 - 300 \times 3.7 = 15725 \text{ pounds.}$$

$$d = \frac{15725}{12 \times .875 \times 40} = 37 \text{ inches.}$$

This cantilever may be made 39 inches at the face of the curtain wall and taper to 12 inches at the toe.

The maximum moment is  $M = 15725 \times 2 \times 12 = 377400$ ,

$$R = \frac{377400}{12 \times 37 \times 37} = 23.$$

$R/f_s = 23/16000 = .0014$ , and from Table IX,  $p = .0015$ .  $A = .0015 \times 12 \times 37 = .67 \text{ in.}^2$ , and from Table XV,  $\frac{5}{8}$ -inch bars spaced 5 inches apart may be used.



## ART. 36. CONSTRUCTION OF RETAINING WALLS

**132. Foundations.**—As stated in Section 126, the most common cause of failure of retaining walls is defective foundations. Careful attention must always be given to the sufficiency of the foundation, footings being arranged so that excessive pressure does not come upon the soil upon which the structure rests.

On compressible soils it is important to equalize the pressures so that settlement under the toe of the wall may not cause the wall to tip forward. In constructing gravity walls this is accomplished by using a footing under the main wall which extends sufficiently beyond the base of the wall to cause the pressures to be equalized over the foundation soil, and bring the resultant near the middle of the foundation. Reinforced concrete walls must be given sufficient base to prevent excessive pressures on the foundation soil.

The extension of the front base cantilever may often be used as a means of securing good distribution of pressures upon the foundation; when this is not feasible, widening the base at the back of the wall may answer the same purpose.

When the soil is compressible, there is always some settlement, and this is greatest where the load is greatest. In many instances, therefore, it may be advisable to extend the footing sufficiently to bring the center of pressure back of the middle of the foundation so as to make the pressure greater at the heel than at the toe of the wall, and produce a tendency to tilt backward.

When soft materials are encountered, or when the pressures cannot be safely distributed over the foundation soil, a pile foundation or some other means of securing firm support for the wall must be employed. Methods of constructing such foundations, and the loads which may be borne by soils are discussed in Chapter XII.

The depth of foundations should be sufficient to prevent freezing in the soil under the footing of the walls, or of the earth in front of the wall at the depth of the bottom of the footing. This usually requires that the footing extend from 3 to 5 feet below the surface of the ground, depending upon local and climatic conditions.

**133. Drainage and Back-Filling.**—Failures of retaining walls have frequently occurred because of the lack of proper drainage, hence provision should always be made for the ready escape of water from the earth behind the wall. If the water is held in and the back-filling becomes saturated, the weight of the material is increased and the angle of friction decreased, thus producing a much heavier pressure

against the wall. Freezing of wet material behind the wall may also produce dangerous pressures against the back of it.

To provide for drainage, weep-holes are commonly left through the base of the wall at intervals of 10 or 15 feet. In concrete walls, these are usually made by the use of drain tile about 3 inches in diameter. In stone masonry walls, the stones are set so as to leave an opening 2 or 3 inches wide through the course of masonry at the base of the wall.

When the back-filling is of retentive material through which water will not readily pass, a layer of cinders, gravel, or some other porous material should be placed against the back of the wall to per-

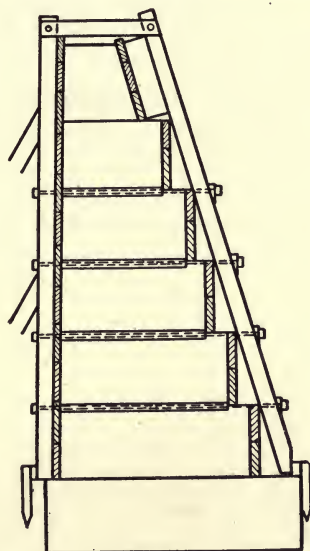

FIG. 70.—Gravity Wall of Concrete

mit the water to reach the drains without difficulty. It is always important that water be not held in the back-filling.

The manner of placing the back-filling may sometimes have an important effect upon the pressures against the wall. The layers in which the filling is placed should slope away from the wall. With some materials, there is a tendency for the earth to slide along the surfaces between the layers in compacting and settling into place, which may materially increase the pressure if inclined toward the wall.

**134. Gravity Walls.**—In constructing gravity walls it is common to give the back of the wall a batter by stepping off the surface, thus

widening the base and making a smaller projection of footing necessary. In walls of stone masonry, the steps are usually the height of one or more courses while in plain concrete walls the steps are usually of uniform height of 2 to 4 feet, to simplify the form work, and for convenience in placing the concrete. Fig. 70 shows a typical section for a wall of this kind, as used for carrying a railway embankment.

It is common to batter the back of a masonry wall at the top for 3 or 4 feet (see Fig. 70) to prevent injury if the backing becomes frozen near the surface and is lifted by the expansion. This is known as *frost batter*, and is commonly 2 or 3 inches to the foot.

Concrete is quite largely replacing stone masonry in the construction of retaining walls. For high walls, reinforced concrete is economical and usually employed, while for walls less than 20 or 25 feet high, gravity walls may often be less expensive than reinforced walls. A larger quantity of concrete is required for the gravity wall, but concrete of less rich character may be employed and no steel is needed. For reinforced walls, about 1 to 6 concrete is usually used for the body of the work, while 1 to 9 concrete may commonly be used for gravity walls; footings being made of 1 to 11 or 1 to 12 mixtures. The cost of forms does not vary greatly for the two types of wall.



## CHAPTER VIII

### MASONRY DAMS

#### ART. 37. GRAVITY DAMS

**135. Stability of Dams.**—A gravity dam, like a retaining wall, depends upon the weight of the mass of masonry to resist the thrust of the water against it. As the dam carries water pressure instead of earth pressure, the loads to which the dam is subjected are definitely known, and the thrusts are everywhere normal to the surfaces of contact.

Let  $ABCD$ , Fig. 71, represent a slice, 1 foot thick, of a gravity dam sustaining a head of water as shown.

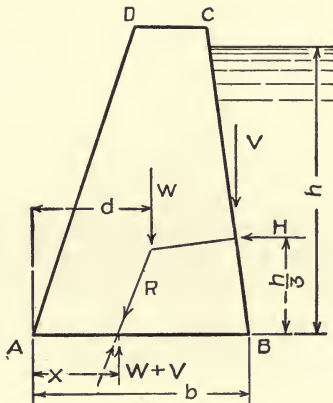

FIG. 71.

- $h$  = height of water above section  $AB$ ;
- $H$  = horizontal pressure of water against the dam;
- $V$  = vertical pressure of water on back of dam;
- $W$  = weight of dam above section  $AB$ ;
- $R$  = resultant pressure upon section  $AB$ ;
- $k$  = horizontal distance from inner edge of base to line of action of  $V$ ;
- $b$  = width of base  $AB$ ;
- $d$  = distance from outer edge of base to line of action of  $W$ ;

$x$  = distance from outer edge of base to point of application of resultant  $R$ .

The conditions of stability for the dam are the same as for the retaining wall:

It must not slide or shear on a horizontal section.

It must not overturn about outer edge of section.

The masonry must not be crushed by pressure upon the section.

*Stability against Sliding.*—Taking the weight of water as 62.5 lb./ft.<sup>3</sup>, the horizontal thrust against the dam above  $AB$  is  $H = 31.25 h^2$ . This is the shear upon the section  $AB$ . If  $AB$  is a joint in the dam, or the base of the dam,  $H$  must be resisted by the friction of the masonry upon the masonry below, or upon the foundation under the dam, and the value of  $H/(W + V)$  must not exceed the coefficient of friction for the material. If  $AB$  is a section in a concrete dam,  $H$  is resisted by the shearing strength of the concrete as well as by the friction.

Continuous joints are not usually employed in construction of masonry dams, and the interlocking of stones eliminates the tendency to slide without shearing blocks of stone. The possibility of sliding need usually only be considered at the foundation.

*Stability against Overturning.*—The overturning moment about the outer edge of the section at  $A$ , due to pressure of water, is

$$M_0 = \frac{1}{2} \times \frac{h}{3} - V(b - k)$$

The resisting moment of the weight of wall is  $M_r = Wd$ , and the distance from the outer edge  $A$  to the point of application of the resultant pressure on the base is

$$x = \frac{M_r - M_0}{W + V} = \frac{Wd - Hh/3 + V(b - k)}{W + V} \dots \dots \dots (1)$$

If the water face of the dam is vertical,  $V = 0$  and

$$x = \frac{Wd - 10.42h^3}{W} \dots \dots \dots (2)$$

Assuming that pressures upon  $AB$  are distributed with uniform variation from  $A$  to  $B$ ,  $x$  should be greater than  $b/3$  in order that no tension may be developed in the section, as in the gravity retaining wall.

*Stability against Crushing.*—The total pressure normal to the section  $AB$  is  $W + V$ , distributed over the section with center of pres-

sure distant  $x$  from  $A$ . The maximum normal unit pressure is therefore (see Section 52)

$$f_c = \frac{(W+V)(4b-6x)}{b^2} \dots \dots \dots (3)$$

This is approximately the crushing stress in the masonry at the outer edge of the section, or the maximum pressure upon the foundation if  $AB$  is the base of the dam.

When the reservoir is empty and the water pressure is removed, the pressure upon the section  $AB$  will be  $W$ , with center of pressure distant  $d$  from the outer edge. The unit pressure at the outer edge of the section will be

$$f_c = \frac{W(4b-6d)}{b^2},$$

and at the inner edge,

$$f'_c = \frac{W(6d-2b)}{b^2} \dots \dots \dots (4)$$

In dams of unsymmetrical cross-sections it is necessary to consider the pressures coming upon the bases of sections when the water pressures are removed, as when the reservoir is empty. In this case, the weight of dam will be the only load, and the centers of pressure due to this weight must always come within the middle third of the base, and the crushing stress be within proper limits, so that removal of the water pressure may produce no harmful effects upon the dam.

**136. Graphical Analysis of Profiles of Dams.**—For low dams carrying small heads of water, trapezoidal cross-sections may be employed, and designs made in the same way as for retaining walls using water pressure instead of earth pressure upon the back face of the dam. As the depth increases such a section becomes increasingly uneconomical and the form of cross-section should be modified so as to make the thickness only that required to carry the load above, and the profile such as to distribute the material to the best advantage.

Fig. 72 shows a method of graphical analysis applied to the section of a gravity dam.  $ookk$  represents a section of a dam 100 feet high. Take a slice of the dam 1 foot thick and of the section shown and divide this by horizontal planes,  $a-a$ ,  $b-b$ ,  $c-c$ , etc., into a number of horizontal layers (in this case, each 10 feet thick).

The weights of the layers,  $ooaa$ ,  $aabb$ , etc., are now computed and plotted to a convenient scale, in the vertical line  $O-K$ . The distance from  $O$  to each of the several points,  $A$ ,  $B$ ,  $C$ , etc., represents the total weight of masonry  $Wa$ ,  $Wb$ , etc., above the corresponding section  $a-a$ ,  $b-b$ , etc., of the dam.



The line of action of the total weight of masonry above each horizontal section must now be found. This may be done by taking moments about a vertical line, or it may be done graphically as follows:

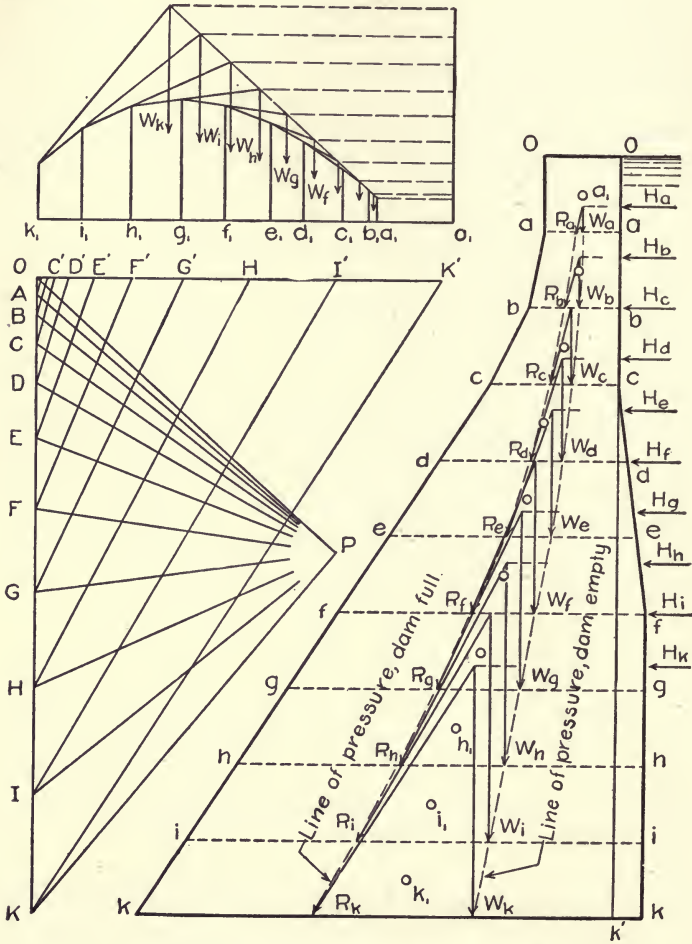

FIG. 72.—Graphical Analysis of Gravity Dam.

The center of gravity of each layer into which the section of the dam has been divided is determined and marked (as shown by the points enclosed by circles). From the point  $o_1$ , lay off on the line  $o_1-k_1$  the distances from the centers of gravity of the layers to any vertical line, as  $o-k'$ . (The scale used in laying off these distances,  $o_1-a_1, o_1-b_1$ , etc., is here made larger than that used for the section

of the dam.) Assume a pole,  $P$ , and draw strings to the weight line  $O-K$ , then from a point on the vertical through  $k_1$  draw the equilibrium polygon as shown, finding the positions of the resultant lines of action,  $Wk$ ,  $Wi$ ,  $Wh$ , etc. The distances of these lines from the vertical through  $o_1$  are the same as the distances of the respective centers of gravity from the line  $o-k'$  on the section of the dam. Plotting these lines of action and drawing them to intersection with the corresponding horizontal sections upon which they act, we find the line of pressure for the dam with no water pressure against it.

When water pressure is against the dam to its full height, the horizontal against any portion  $h$  feet in depth below the surface is  $H=31.25 h^2$ . These pressures may be computed for each of the horizontal sections, and each resultant pressure acts on a horizontal line at one-third the height from the section to the surface of the water, as shown,  $Ha$ ,  $Hb$ , etc.

On the horizontal line  $O-K'$ , make the distances  $O-A'$ ,  $O-B'$ , etc., equal the values of the water pressures  $Ha$ ,  $Hb$ , etc., to the same scale as used for the weights of masonry. The lines  $A-A'$ ,  $B-B'$ , etc., now represent, in direction and amount, the resultant pressures,  $Ra$ ,  $Rb$ ,  $Rc$ , etc., upon the various horizontal sections  $aa$ ,  $bb$ ,  $cc$ , etc., of the dam. Lines drawn parallel to these directions through the intersections of the corresponding  $H$  and  $W$  lines of action give the points of application of these resultants upon the various sections, and locate the lines of pressure with water against the dam to the top.

**137. Design of Profile.**—In designing a profile, for a dam we commence at the top with the assumed thickness and find by trial the required base thickness for each horizontal layer, making each thickness such that the line of pressure remains everywhere within the middle third of the section. This may be done by the use of the formulas given in Section 135 or by the graphical method of Section 136.

The crushing stress upon the masonry must also be kept within safe limits.

Let  $b$  = the width of the section;

$x$  = the distance from the outer edge to the point of application of  $R$ ;

$y$  = the distance from the inner edge to the point of application of  $W$ .

The maximum crushing stress at the outer edge of the section is given by the formula,

$$f_c = \frac{W(4b-6x)}{b^2} \dots \dots \dots (5)$$

The maximum crushing stress at the inner edge is

$$f'_c = \frac{W(4b - 6y)}{l^2} \dots \dots \dots (6)$$

The allowable crushing stress depends upon the quality of masonry used, and the conditions under which the dam is to be constructed. In high dams, where the front face of the dam has considerable batter, the pressure allowed at the outer face is often made less than that at the inner face. The maximum pressure at the inner edge of a section occurs when the dam carries no water pressure, and the resultant pressure on the base is vertical. The maximum pressure at the outer edge occurs when full water pressure is on the dam, the batter of the outer face is greater than that of the inner face, and the resultant pressure is inclined, only its vertical component being considered in determining the stress. For these reasons Rankine's recommendation that the allowable unit crushing stress at the outer edge be made less than that at the inner edge has been followed by some designers. Pressures of from 8 to 15 tons per square foot have been allowed in a number of large dams of massive rubble or cyclopean concrete.

The profile resulting from this method of design is somewhat irregular and may be modified by fitting it with more uniform batters and smooth curves, thus giving a more pleasing appearance and better profiles for construction purposes, without appreciably affecting its stability.

*Vertical Water Pressure.*—As the water face of the dam is nearly vertical, it is usual to disregard the vertical component of the water pressure, which is of small consequence in dams of less than about 180 to 200 feet in height. This component has the effect of diminishing the stress upon the outer edge of the section while somewhat increasing the total pressure. Its neglect is therefore a small error on the safe side until a depth is reached at which the slope of the inner face may make it of more importance.

The shape of the profile depends upon the top width given to the dam, and the weight of the masonry used.

*The top width* must be sufficient to resist any probable wave action and ice pressure, and should usually be made greater for high dams than for low ones. This is a matter of judgment in each case, about one-tenth of the height of dam being frequently used, with a minimum of about 5 feet and a maximum of 20 feet where no roadway is carried on top of the dam.

The dam should always extend to a sufficient height above the



normal water surface to prevent water passing over the dam due to waves of floods for which wasteways might not be quite sufficient. This may require the dam to be raised 5 or 10 feet above the elevation of the expected water surface. In designing the dam, water should be assumed level with the top.

*The weight of masonry* used in dam construction commonly varies from about 135 to 150 pounds per cubic foot. The heavier the masonry is assumed to be, the less the required width of section until a depth is reached at which the width is determined by the necessity of providing sufficient area to carry the weight of masonry above. Below this point, usually about 200 feet below the water surface, the width required is greater for the heavier masonry if the same unit compression be allowed.

*Uplift and Ice Pressure.*—If water under hydrostatic pressure has access to the interior of the dam, the upward pressure will tend to lift the masonry and diminish its effective weight in the moment which prevents overturning. In this discussion it has been assumed that the dam is constructed water-tight, but as this is not altogether possible, in many instances it may be necessary to allow for upward pressure in designing the profile, or make special provision for drainage—a topic discussed in Section 140.

If ice forms on the surface when the reservoir is full, a considerable pressure may be brought against the top of the dam, which should be considered in its design. This will be a concentrated horizontal thrust at the surface of the water equal to the crushing strength of the ice, and has been assumed in a number of important dams at from 2500 to 4500 pounds per linear foot of dam. In storage reservoirs generally, heavy ice is not likely to occur with full reservoir, and if water be low when freezing occurs no special allowance for ice pressure is necessary. Local conditions must determine the necessity of allowing for ice pressure in each instance.

**138. Diagonal Compressions.**—The common method of analysis, already described, considers only the stresses upon horizontal sections and resolves the diagonal thrusts into normal compressions and parallel shears upon these sections. This method does not give the actual maximum compressions, but by using proper unit stresses has seemed to give satisfactory results in use. Several methods have been proposed for computing more accurately the maximum unit compressions.

*Diagonal Compression upon Horizontal Section.*—In 1874 Bouvier<sup>1</sup> used the actual diagonal pressure ( $R$ , Fig. 72) in computing the

<sup>1</sup> Annales des Ponts et Chaussées, 1875.

maximum unit compression upon a horizontal section, claiming that the unit compressive stresses produced by  $R$  parallel to its line of action are greater than those normal to the section. He considered  $R$  to be distributed along  $A-B$ , so as to act upon successive small sections normal to its direction as shown in Fig. 73. If  $\beta$  is the angle made by  $R$  with the normal to section  $A-B$ , and  $b$  is the width of section, the area upon which  $R$  acts is  $AC = b \cdot \cos \cdot \beta$ , and the maximum intensity of the compressive stresses is

$$f_{cd} = \frac{R(4b - 6x)}{b^2 \cos \cdot \beta} = \frac{W(4b - 6x)}{b^2 \cos^2 \beta} = \frac{f_c}{\cos^2 \beta} \dots \dots (7)$$

in which  $f_{cd}$  is the unit compression at the outer edge of the section parallel to  $R$ , and  $f_c$  is that normal to the section at the same point.

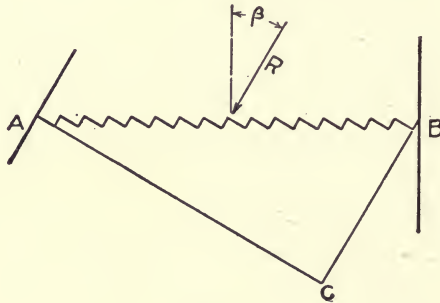

FIG. 73.

Professor Unwin<sup>1</sup> has shown that the maximum unit compression at the face of the dam occurs on a section normal to the face, and that the maximum value of this compression at the outer edge of a horizontal section through the dam is  $f_{cm} = \frac{f_c}{\cos^2 \theta}$ , in which  $f_c$  is the value of unit vertical compression and  $\theta$  is the angle made by the batter of the face of the dam with the vertical.

A method of finding the maximum diagonal compression and its direction at any point of a horizontal section of the profile of a dam is given by Professor Cain,<sup>2</sup> which agrees practically with Unwin's results for the stress at the edge.

*Compression upon Inclined Sections.*—The distribution of pressure upon an inclined section is sometimes investigated and the maximum unit stress at the outer face of the dam found to be greater than that

<sup>1</sup> Proceedings, Institution of Civil Engineers, Vol. CLXXII, Part II.

<sup>2</sup> Transactions, Am. Soc. C. E., September, 1909.

for a horizontal section. In Fig. 74 using the same profile employed in Fig. 72, the pressure upon the inclined section  $k-n$  is that due to the water pressure ( $H$ ) upon the inner face  $O-K$  of the dam combined with the weight of masonry ( $W$ ) above the section  $k-n$ . The unit compression at  $n$  is obtained in the same manner as for the horizontal section. This stress for this profile is greater than for the same point when obtained by using the horizontal section through  $n$ , and about the same as that at the outer edge of the base section  $k-k$ .

*Lateral Distribution of Stress.*—In the trapezoidal distribution of stress, which considers the stresses to vary uniformly from the inner to the outer edge of the section,

it is assumed that the whole width of the dam acts together as a single homogeneous body. It is not probable that this is the case in a wide section. The middle portion of the section carries more and the edges less stress than the assumed distribution shows, and for this reason many designers have considered that the ordinary method, with low allowable stress upon the outer edge, as proposed by Rankine, to be sufficiently exact. The

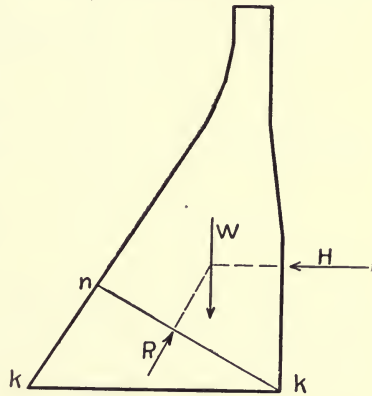

FIG. 74.

ordinary method, taking successive horizontal sections, provides an easy way of determining an approximate profile. Careful study should, however, be given to the possible diagonal stresses in a high dam, and if such stresses exceed the allowable unit compression, the profile should be widened so as sufficiently to reduce them.

**139. Horizontal Tension.**—Experiments have been made by Sir J. W. Ottley and Mr. A. W. Brightmore<sup>1</sup> upon models of dams made of plasticine (a kind of modeling clay), and by Messrs. J. W. Wilson and W. Gore<sup>2</sup> on models made of india rubber.

The distribution of stresses through the profile was determined in each case by observing the horizontal and vertical displacement of points in the section. These experiments seemed to confirm, in general, the ordinary theory of the trapezoidal distribution of stresses, and to justify the methods of design in common use.

At the base of the dam, where the profile section joins the founda-

<sup>1</sup> Proceedings, Institution of Civil Engineers, Vol. CLXXII, p. 89.

<sup>2</sup> Proceedings, Institution of Civil Engineers, Vol. CLXXII, p. 107.



tion, it was found that a different distribution of stress occurs, tension being developed at the inner edge of the base by the immovability of the foundation. Thus, in Fig. 75 the shear on  $A-B$ , due to the horizontal water pressure causes horizontal or diagonal tension ( $T$ ) in the foundation at the inner edge ( $A$ ) of the base. In the plasticine models diagonal cracks ( $A-C$ ) occurred at this point in the foundation.

Various methods have been suggested for meeting or reducing this tension by modifying the shape of the profile at the base or reinforcing the foundation. This does not seem necessary for dams as usually constructed. A high masonry dam is usually on solid rock foundation, and the strength of the rock is such that no break in the foundation is to be anticipated from this cause. In most dams the foundation is in rock at considerable depth below the bed of the stream, and the

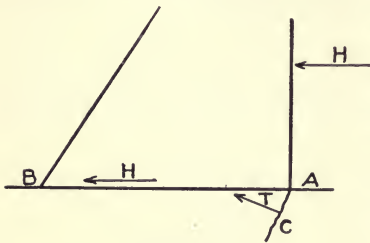

FIG. 75.

lower part of the dam is enclosed on both sides by gravel or other soil which usually may be considered to strengthen the dam, although the full depth of water pressure should be assumed to act upon it. If, however, this filling is soft material, which flows when saturated, it may increase the pressure against the dam and may be considered as a fluid heavier than water.

**140. Uplift.**—If a dam be so constructed that water under pressure may penetrate into the interior of the dam or under its base, the effect of such pressure must be considered in its design. There is considerable difference of opinion among engineers concerning the necessity of providing for uplift in designing the profiles for dams. Some allow for it in all cases; while others claim that properly constructed masonry or concrete will be so nearly water-tight that the effect of uplift may be neglected.

*Interior Pressure.*—It is always possible that some water may be forced into imperfect joints in the masonry and, if it be prevented from escaping at the lower side of the dam, have the full hydrostatic pressure of the head in the reservoir. For this reason it is important that the water face of the dam be made as nearly impervious as possible, and that the interior of the dam be drained so that any water passing into the masonry may escape without damage. It is evident that uplift of the interior of the masonry can exist only where continuous joints for considerable distances are filled with water under pressure.

If concrete be porous and its voids filled with water under hydrostatic pressure, no uplift occurs until the pressure becomes sufficient to overcome the cohesive strength of the concrete. In properly constructed masonry dams, it is usually unnecessary to consider the effect of uplift on sections above the base of the dam.

*Upward Pressure on Base.*—The probability of uplift under the base of a dam depends upon the character of the foundation. Careful attention should always be given to the determination of the character of the foundation material to considerable depths below the base of the dam. The kind of material of which the foundation is composed, and the existence of seams in the rock, or of strata of permeable material must be accurately investigated.

When the foundation is of solid rock without seams, if care be used in joining the base to the foundation and cut-off wall be used under the inner edge of the base, there is little chance of appreciable uplift under the base.

When the foundation is permeable and there is water against both sides, as is frequently the case in dock walls, the full hydrostatic head is usually considered to act under the whole base. This is somewhat excessive, as it implies that the dam is floating upon a continuous surface of water. Probably two-thirds of this pressure would represent about the maximum which could reasonably be expected in any case.

When the foundation is stratified horizontally, so that water may be expected to pass under the dam and escape below, a uniformly diminishing upward pressure from the inner to the outer edge of the base may be assumed; the pressure at the inner edge being taken at about two-thirds the hydrostatic head above the dam, and that at the lower edge at zero.

The probability of upward pressure on the foundation should always be carefully investigated, and the section, where necessary, increased sufficiently to provide weight of masonry to overcome the overturning moment of this water pressure. This subject is very fully treated in the discussion of a paper by the late C. L. Harrison in the Transactions of the American Society of Civil Engineers for December, 1912. Mr. Harrison's conclusions are:

1. For any stable dam, the uplift in the foundation cannot act over the entire area of any horizontal seam, and in the masonry it cannot act over the entire area of any horizontal joint.

2. The intensity of uplift at the heel of the dam can never be more, and is generally less, than that due to the static head. Also, this uplift decreases in intensity from the heel to the toe of the dam,

where it will be zero if the water escapes freely, and will be that due to the static head if the water is trapped.

3. The uplift in the foundation should be minimized by a cut-off wall, under-drainage, and grouting when applicable; and in the dam itself by using good materials and workmanship, and by drainage when advisable.

4. The design should be based on the conditions found to exist at each site after a thorough investigation by borings, test-pits, and otherwise, and modified if found necessary after bed-rock is uncovered.

### ART. 38. DAMS CURVED IN PLAN

**141. Curved Gravity Dams.**—In constructing dams across narrow valleys, it is often desirable to curve the dam in plan, so as to make it form a horizontal arch, convex upstream. When so arranged, a portion of the water pressure may be transmitted to the sides of the valley by arch action, thus diminishing the overturning moment which would exist in a straight dam of the same section.

In certain locations, the shape of the valley and depth of suitable foundations make the use of the curved form economical in saving materials, although the length of dam is increased by the curvature. The curved form for gravity dams has not usually been adopted for the purpose of securing the arch action, although the advantage of the curved form is recognized and the added security obtained by the possibility of the upper part of the dam acting as an arch is worth considering when it does not materially increase the cost.

In order to develop free arch action in any horizontal slice of a dam, it would be necessary that the section be free to move horizontally when the pressure comes against it. As each section is rigidly connected with these above and below it and the base is attached to a practically immovable foundation, the arch action is very imperfect. Near the top of a gravity section, deflection of the section may be sufficient to permit a portion of the water pressure to be resisted by the arch, but in the lower half of the dam such resistance is inappreciable.

There is no satisfactory way of determining how much of the pressure is borne by the arch in a curved gravity dam. In an analysis of the stresses in the Cheeseman dam, Mr. Silas H. Woodward estimated <sup>1</sup> roughly the amount of water pressure carried by the arch action, by determining the deflection at various points in the mid-section of the dam, considering the resistance of horizontal slices

<sup>1</sup> Transactions, Am. Soc. C. E., Vol. LIII, p. 108.



of the dam by arch action, and the resistance of a vertical slice as a cantilever beam, fixed at the bottom to the foundation. He concluded that in the Cheeseman dam, the arch carried about half the water pressure at the top and about 6 per cent at the mid-height of the middle section.

Mr. Woodward's analysis seemed to indicate that, while added security might be obtained through arch action at the top of the dam, the lines of pressure of the gravity section were only slightly modified by considering part of the load carried by the arch. His conclusion was that no diminution of the gravity section would be justified because of dependence upon arch action.

The use of curved plans for gravity dams may be of advantage in affording a possibility of motion when expansion and contraction take place, without cracking the masonry. The advantages to be gained by using curved plans, however, do not seem sufficient to make them worth while when they involve increase in cost. In constructing gravity dams across narrow valleys where arch action might be developed, the sides of the valley may also offer considerable support to a straight dam, causing horizontal slices of the dam to act as beams supported at the ends. In any such dam the actual stresses are probably considerably less than those obtained by considering the gravity resistance only.

**142. Arch Dams.**—Dams are sometimes constructed which depend for stability mainly upon arch action, and are designed as horizontal arches. A number of dams of this type have been constructed across narrow valleys, with sections much lighter than could be used for gravity dams. In some, the lines of pressure fall quite outside the bases when considered as gravity sections.

Let  $A-B$ , Fig. 76, represent a horizontal slice, 1 foot thick, through a circular dam.

- $R$  = radius of water face;
- $t$  = thickness of section;
- $P$  = water pressure per foot of length;
- $f_c$  = unit compression on the masonry;
- $h$  = height of water surface above section;
- $w$  = weight of water per cubic foot.

If the slice be supposed to act freely as an arch and carry the water pressure to the abutments,

$$f_c = \frac{PR}{t} = \frac{whR}{t} \dots \dots \dots (8)$$

If a limiting value of  $f_c$  be assumed, the thickness of section required at any depth will be

$$t = \frac{PR}{f_c} = \frac{whR}{f_c}.$$

For a dam of constant radius ( $R$ ) the required thickness varies uniformly with  $h$ , or the vertical section of the dam is triangular.

As the ends of the arch at  $A$  and  $B$  are built into the sides of the valley and not free to move toward the center  $O$  when subjected to the water pressure, the lines of thrust of the arch will not be exactly axial as assumed in Formula (8), and bending stresses will develop in the arch, giving a maximum compression somewhat greater than the average value. This effect will usually be small as compared with the stress due to arch action, although French authorities recommend

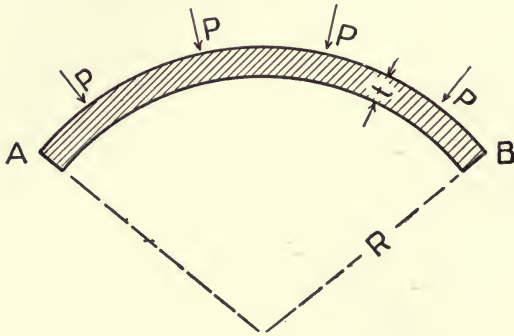

FIG. 76.

that the line of thrust be assumed at the outer edge of the middle third at the crown, thus making the maximum compression double the average. The use of vertical expansion joints through the dam, dividing it into voussoirs, has the effect of largely eliminating the bending stresses. In practice the bending stress is commonly neglected, very conservative values for  $f_c$  being used.

When the length of the arch is small as compared with its thickness, it becomes a curved wedge which acts as a beam between the abutments supporting its ends, and should be considered as a curved beam—a condition frequently occurring near the bottom of a curved dam, where the valley is narrow and the thickness of the dam considerable. The thickness obtained by considering such a section as an arch is always sufficient.

A masonry structure cannot be considered to act as an arch when the thickness of the arch ring is more than from one-quarter to one-

third of the radius of its outer surface. The exact limitations within which such action may take place are not definitely known and are seldom of importance in a dam.

*Resistance of Vertical Cantilever.*—As a dam is rigidly fastened to the foundation, it is evident that complete arch action cannot take place, and that in the lower part of the dam, the arch can carry very little of the load. A vertical section of the dam may be considered as a cantilever fixed at the bottom as in a gravity dam, and the resistance of the cantilever to deflection will limit the extent to which arch action may occur.

Attempts have been made by estimating the relative deflections of the horizontal arch and the vertical cantilever at various heights upon the mid-section of the dam, to determine what portion of the load is resisted by each. Such studies have been made by Mr. Silas H. Woodward<sup>1</sup> for the Lake Cheeseman dam, which is a curved dam of gravity section (see Section 141) and by Mr. Edgar T. Wheeler<sup>2</sup> for the Pathfinder dam, which was designed as an arch, and has a section considerably lighter than could have been employed in a gravity dam. The section of the dam has a width of 10 feet at the top, a batter of .25 on the downstream and .15 on the upstream face.

These analyses, with accompanying discussions, are interesting as throwing light upon the probable action of such dams when subjected to water pressure, but afford no means of determining the actual stresses occurring. The vertical cantilever has the effect of reducing the stresses in the arches, but it is not proposed to consider the combined actions in designing dams, or to attempt to use the actual stresses, as limited by the cantilever resistance in proportioning the arches. In practice, the arches are given sections which would enable them to carry the whole water pressure, and the vertical resistance is considered as a source of additional security.

*Horizontal Shear.*—As the dam is fixed at the bottom to the foundation and the various horizontal slices are not free to act independently of each other, the thickness at any point should be sufficient to carry the total water pressure above as horizontal shear. If  $S$  be the safe unit shear per square foot, the thickness should not be less than  $t = \frac{wh^2}{2S}$ . Such shearing stresses can exist only near the bottom of the dam, where it is rigidly attached to the foundation, and can never reach the assumed value if the water pressures toward the top of the dam are carried by arch action.

<sup>1</sup> Transactions, Am. Soc. C. E., Vol. LIII, p. 89.

<sup>2</sup> Engineering News, August 10, 1905.



*Weight of Masonry.*—Each horizontal slice of an arch dam must carry the weight of the portion of the dam above as a vertical compression. This compression is computed as in the gravity section when the dam is empty, and must not exceed a safe unit stress on any part of the section. The weight of masonry above also produces a distortion of the horizontal section. The value of Poisson's ratio for concrete may be taken as approximately one-fifth of the unit horizontal compression produced through the mass of masonry, if prevented from expanding laterally is approximately one-fifth of the unit vertical compression which causes it. The effect of this horizontal compression is to cause an expansion of the horizontal section, increasing the length of the arch ring, and deflecting the crown of the arch upstream. When water pressure is brought against the dam, a portion of the pressure, sufficient to produce compression in the arch equal to the unit horizontal pressure due to the vertical load, will be used to bring the arch back to its initial position, and no deflection due to arch action will occur until this pressure has been passed.

When the crown of the arch has been deflected upstream by the weight of masonry, stress is brought upon the vertical cantilever by its resistance to bending in that direction. If water pressure be now brought against the dam, the vertical cantilever action will offer no resistance to downstream motion until the pressure upon the arches becomes sufficient to bring the dam back to its original unloaded position.

The existence of this initial distortion due to the weight of masonry may depend upon the manner in which the dam is constructed. In order to produce this effect it is necessary that the horizontal layers be completed and hardened in position before the load above is applied. If portions of the work be carried up in vertical sections, or if vertical contraction joints be left, to be afterward grouted, the deflection due to weight of masonry may take place only to a very limited extent.

*Constant-angle Arches.*—Arch dams are usually constructed across narrow gorges which can readily be spanned by an arch of moderate radius. The gorges vary in cross-section, being usually much narrower at bottom than near the top of the arch. The arch at bottom will therefore be much shorter than at the top and if the same radius be used at top and bottom, or the centers lie in the same vertical line, the central angle included by the dam will be greater at top than at bottom. It has been shown by Mr. Lars R. Jorgensen<sup>1</sup> that a dam with a constant central angle of  $133^{\circ} 34'$  requires, theoretically,

<sup>1</sup> Transactions, Am. Soc. C. E., Vol. LXXVIII, p. 685.

the minimum amount of masonry in its construction, and that angles from  $110^\circ$  to  $150^\circ$  vary but little from the minimum. It has therefore been proposed to vary the radius from the top to the bottom, so as to keep within these ranges of central angles. This makes the radius of the dam vary with the width of the gorge at different elevations. Several dams have been constructed in which this principle has been approximately applied. The topography of the site must be carefully studied in every instance and the dam fitted to its location, keeping in mind the general principles involved.

*Temperature Stresses.*—Comparatively little is known concerning the changes of temperature to be expected in a mass of masonry like a dam, but it is evident that distortions produced by such changes may sometimes be of importance, and careful attention should be given to their probable effect. Temperature above the normal at which the masonry was placed cause deflection upstream through expansion, which may bring bending stresses upon the vertical section when the water is low behind the dam. Contractions due to temperatures below the normal, causing tensile stresses which the masonry or concrete is not calculated to bear may cause cracks, or prevent the arch action through shortening the arch near the top. It is desirable that masonry which may be injuriously affected by low temperature, be placed when the temperature is low, thus giving a low normal and probable small range below. Mr. Wisner<sup>1</sup> urges that reinforcement be used on the faces of the upper portion of arched dams to prevent cracks; vertical rods on the downstream face to take up the possible vertical tensions due to expansion, and horizontal rods on the upstream side to prevent contraction cracks.

**143. Multiple-Arch Dams.**—Dams consisting of a series of concrete arches supported by buttresses are sometimes used for moderate heights where suitable foundations are available and the cost of gravity dams would be greater. The amount of concrete required is much less than for gravity dams, and where concrete materials are expensive considerable savings in cost may result from their use. The form work required and the thin sections of concrete, make the unit costs much more than for gravity dams, and under favorable conditions for cheap concrete work gravity sections may be cheaper to construct. As the buttresses must carry the thrust of the water pressure, it is essential that they be established upon very substantial and unyielding foundations. Usually this is solid rock, although some dams of this type have been built upon gravel or fissured rock. Where the foundation is stable but of character which may permit

<sup>1</sup> Engineering News, August 10, 1905.

water to penetrate it, this type of dam has advantages over a gravity dam on account of the less importance of possible uplift.

Two types of multiple-arch dams are in use; (1) those in which the axes of the arches are vertical, the water pressures coming horizontally against the faces and being transmitted as horizontal thrusts against the buttresses; (2) those with inclined axes, the water pressures acting normal to the sloping axes and bringing vertical as well as horizontal thrusts upon the buttresses.

Let Fig. 77 represent an inclined arch dam. A slice of the arch ring normal to the axis carries a water pressure which varies from the crown to the springing line, and also carries a portion of its own weight to the buttress. If a slice of the arch ring be divided into voussoirs as shown, the water pressures upon each voussoir ( $P_1-P_5$ ) varies with the depth ( $h_1-h_5$ ) below the surface of the water. The

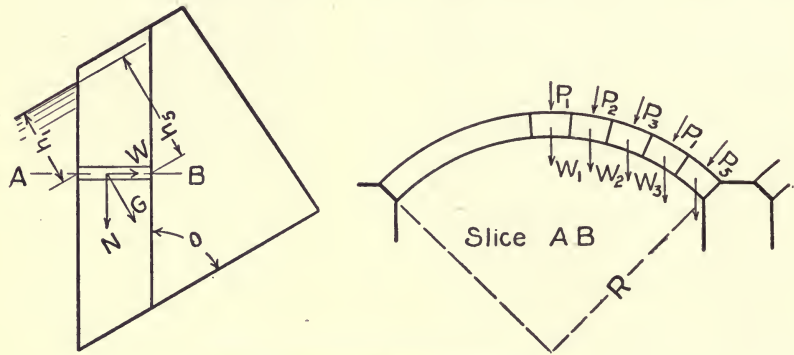

FIG. 77.—Inclined Multiple-Arch Dam.

weights of the voussoirs ( $G_1-G_5$ ) may be considered as divided into components, ( $N=G \cos \theta$ ) normal to the section and ( $W=G \sin \theta$ ) parallel to the section. The normal components are carried as longitudinal thrusts to the foundation, while the parallel components ( $W_1-W_5$ ) are carried by the arch ring to the buttress. Having determined these loads, an approximate line of thrust may be drawn by the method used for voussoir arches (see Section 162), from which stresses may be determined.

In designing such an arch, the required thickness at various depths may be approximately determined by finding the thickness for a horizontal arch at the same depth, then using this thickness in the analysis, modifying it as required. Practically an assumed thickness is given the ring at the top and tapered to the required thickness at some point below.



When the arch axis is vertical, the arch carries only the water pressure, which is uniformly distributed over the face. The weight of the arch, in this case, is normal to the arch section and is carried vertically to the foundation. The thickness required for the arch ring may be found from Formula (8), (Art. 138).

The stresses upon the buttresses of a multiple-arch dam may be found by the methods used for gravity dams. In Fig. 78  $E-F$  is a section through the crown of an inclined arch;  $ABCD$  being the side projection of the buttress. The form of the buttress must be such that the resultant thrust upon any horizontal section  $A-B$  will act approximately at the middle of the section. The loads acting are:

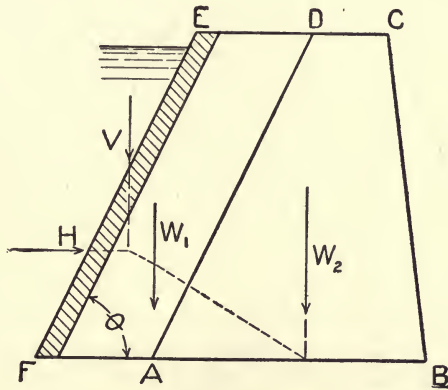

FIG. 78.

(1) The horizontal water pressure ( $H = \frac{1}{2}wh^2L$ ) due to the depth of water above the plane  $A-B$ , upon a length of dam ( $L$ ) equal to the distance between the middle points of adjacent arches.

(2) The vertical water pressure ( $V = H \cdot \tan \cdot \theta$ ). The center of pressure for the vertical water pressure is at the center of gravity of a horizontal section of the water face of the arch at two-thirds the depth below the surface of the water.

(3) The weight ( $W_1$ ) of the two half arches upon each side of the buttress. The center of gravity for the weight of the arch is at the center of gravity of the center line of a horizontal section of the arch ring which passes through the center of gravity of the vertical section ( $E-F$ ) of the crown of the arch. If the centers of gravity of the center lines of the arch ring be determined for horizontal sections at the top and bottom of the arch, all intermediate centers will lie upon the line joining these points.

(4) The weight of the buttress itself, acting through its center of gravity.

The resultant ( $R$ ) of these loads should cut the base  $A-B$  near its middle point, in order to secure uniform distribution of pressure over the section.

Buttresses, for dams of this type, are usually made very thin in comparison with their widths, and are therefore stiffened laterally by the use of horizontal struts from buttress to buttress, or by the use of cross walls. The design of these struts is purely a matter of judgment on the part of the designer.

In the design of multiple-arch dams, the general lay out is a matter which must depend upon local topography. Each dam is a problem by itself, and must be made to fit its location. It has been found that in some instances, where the conditions are favorable to the construction of masonry dams of moderate height, multiple-arch dams may be built at much less cost than gravity structures. Forty to 60 or 70 feet between centers of buttresses are commonly found economical distances. Arches with axes making angles of  $30^\circ$  or  $40^\circ$  with the vertical are apt to show some saving of material as compared with vertical axes, but this is not always the case. The unit cost of construction is usually somewhat greater for inclined arches.

In constructing gravity dams, a cheaper grade of masonry may be employed, and the form work costs less than for multiple-arch dams. Careful studies of local conditions, and tentative trial designs are necessary in each case for best results.

*Temperature Stresses*, due to temperatures lower than those at which the arches are constructed, are to be expected in all structures. These produce shortening of the arch and give tensile stresses which may result in cracks when the dam is empty. Horizontal reinforcement near the downstream face at the crown and near the upstream face at the springing line is desirable to resist this tendency to crack.

### ART. 39. REINFORCED CONCRETE DAMS

**144. Reinforcement in Arch Dams.**—Several designers have used steel reinforcement in arch dams, where it has seemed desirable to prevent the possible development of cracks, or to give additional security where the uncertainty concerning stresses made tensions seem possible under certain conditions. Cracks which may result from changes of temperature when dams are empty are frequently guarded against by using reinforcement, as has been mentioned in the previous articles. The stresses in most of these cases are practically indeter-

minate, and the reinforcement is placed according to the judgment of the designer.

These structures are sometimes called reinforced concrete dams in published reports, but are not designed as reinforced structures and are not properly so classed. No fully reinforced arch dams have as yet been constructed, and no dams have been designed in which the stresses have been determined by the use of the theory of the elastic arch.

**145. Flat Slab and Buttress Dams.**—For dams of moderate height reinforced flat slab and buttress construction has frequently proven economical. In this type of construction the buttresses are usually placed from 12 to 18 feet apart, and the slabs extending between buttresses are inclined at an angle of  $40^\circ$  to  $45^\circ$  with the vertical so that the resultant of the normal water pressures passes near the middle of the base of the buttress. Most of the dams of this type in use have been constructed under the patents of the Ambursen Hydraulic Construction Company.

Fig. 79 shows a dam of this type in section through the inclined slab. The loads carried by the slab consist of the normal water pres-

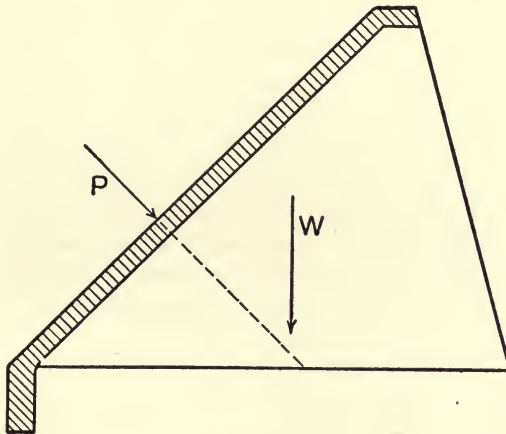

FIG. 79.

sure and the normal component of its own weight. The slab may be designed by the ordinary method for reinforced concrete beams, but the values used for allowable stresses should be very conservative.

The buttress should be made of sufficient width to cause the resultant thrust upon its base to pass approximately through its middle point when fully loaded, and must have sufficient base area



to keep the pressure upon the foundation within reasonable limits. Lateral stiffness of the buttresses may be provided by giving them sufficient thickness, and using reinforcement on the sides, or it may be obtained by ties and struts between buttresses.

‘ In many dams of this type, cellular construction is adopted, in which the spaces between buttresses are divided into cells by horizontal floors, openings through the buttresses providing opportunity to pass under the dam throughout its length. Sometimes vertical walls provide rooms which may be utilized for power house or other purposes.

Slab and buttress dams, like any other masonry dams, require firm foundations. For locations where substantial foundations may be obtained for buttresses on porous material, they possess an advantage over gravity dams which would be subjected to upward pressure. In these cases it is necessary to provide cut-off walls at the heel of the dam to prevent water passing under and washing out the foundation.

#### ART. 40. CONSTRUCTION OF MASONRY DAMS

**146. Foundations.**—Masonry dams are ordinarily applicable only to situations where foundations of solid rock may be obtained. Careful examinations of the character of the rock should always be made to considerable depths below the foundation in order to make sure that no seams or strata of porous materials exist, which might cause slipping of the foundation when subjected to pressure of water behind the dam.

Nearly all of the failures of masonry dams which have been recorded have been due to defective foundations, causing settlements through washing out the foundation materials, or sliding of base of dam, and foundation on seams or soft strata through which water under pressure found its way.

Where the depth to solid rock is considerable and the rock or gravel near the surface is of a character to give substantial support to the structure, masonry dams may sometimes be used without carrying the base of the dam into the solid rock. In such cases, curtain walls at the heel of the dam should be carried down to the rock to shut off leakage and possible washing of the foundation.

When the rock is seamed or fissured, it may frequently be made tight by grouting, which is done by drilling into it and forcing grout (usually of neat cement and water) under pressure into the fissures until the cracks become sufficiently filled to force grout to the surface through adjacent drill holes.

When a high dam is to be constructed, the geological structure of the valley should be studied, and core drill borings made over the site of the dam so as to determine fully the stability of the foundation and the probability of leakage around or under the dam.

The placing of the foundations of a dam is usually the most difficult part of the work of construction. Commonly it is necessary to divert the water of the stream to be damned, and seepage water must be handled in making the excavations and placing the masonry. The methods used in such work are described in Mr. Chester W. Smith's "Construction of Masonry Dams," New York, 1915.

**147. Masonry for Dams.**—Several types of masonry are sometimes used in dams of massive construction.

*Heavy rubble masonry* has commonly been employed, in which the large stones are set in mortar beds, and the vertical joints filled with mortar and small stones carefully placed by masons. The stones are put into place by derricks and must be held and lowered so as to seat evenly upon the mortar bed, being set with careful attention to bond, so that no continuous joints exist in any direction. The complete filling of all joints is important.

*Cyclopean masonry*, in which the large rubble stones are set in beds of concrete and the joints filled with soft concrete, has recently been used to considerable extent. The joints are made thicker than mortar joints, and the labor required in setting the stones and making good joints is much less than in the ordinary rubble.

*Rubble concrete* is masonry in which rubble stones are distributed through a mass of concrete. In some cases, boulders of considerable size are used in such work. This differs from cyclopean masonry mainly in the smaller amount of large stone used and larger quantity of concrete. It uses more cement, but is more rapidly constructed and requires less hand labor.

*Plain concrete* is now frequently used, without large stone, for massive work, as well as for the dams of thin sections. The plant required is less, as derricks are needed for handling the heavy stone, and usually more rapid progress is possible in placing the concrete. The nature and location of materials and character of labor available determine the relative costs of the different methods of construction. The rapidity of construction is usually greater as the quantity of large stone becomes less.

**148. Overflow Dams.**—When water is to flow over the top of a dam or spillway, the section must be modified to provide for the passing of the water with the least disturbance possible, and to take into account the additional head of water above the dam.

If the water falls freely over the dam, its crest should be given such form as to eliminate the possibility of causing a vacuum behind the sheet of falling water. The effect of the impact of the falling water must also be taken into account, and provision made for protecting the toe of the dam against erosion, which is frequently done by providing a water cushion into which the stream may fall.

In overflow weirs of considerable height, the downstream face of the dam is given approximately the form of the curve that the water would take in falling freely over the weir under maximum head. The water may then follow the surface of the dam, and, by reversing the curve in the lower part of the section, be turned to horizontal direction at the toe of the dam. In designing such a section, the weight of the water on the downstream face is neglected, the pressure on the upstream face being taken as that due to the full head at greatest expected flood. Special attention should also be given to the possibility of uplift or of scouring at the toe.



## CHAPTER IX

### SLAB AND GIRDER BRIDGES

#### ART. 41. LOADINGS FOR SHORT BRIDGES

**149. Highway Bridges.**—*Sidewalks* of bridges in towns may be considered as carrying a live load of 100 pounds per square foot of sidewalk area. In the more crowded districts of cities, larger loads are sometimes employed, but in general this is ample for all probable occurrences.

*Roadways of highway bridges* should be able to carry the heaviest motor trucks which may reasonably be expected to come upon them. In the development of truck transportation there is a tendency to increase the weights carried by a single truck, and careful attention should be given to this possibility in designing bridges intended to last a long time. A motor truck weighing 20 tons, with 6 tons on one axle and 14 tons on the other, the distance between wheels being 6 feet and between axles 12 feet, may reasonably be assumed as a maximum load for a bridge upon an important country highway or street of a town. This load is a very exceptional one for ordinary highways and probably in most cases a truck weighing 7 to 10 tons is as large as is likely to be met under present conditions, and possibly a road roller may be a more probable maximum load. The use of maximum loads not likely to be exceeded in the near future is always desirable in such work.

For country bridges under moderate or light traffic, a truck weighing 8000 pounds on each of two axles, 10 feet apart, may be used as a probable maximum load under present conditions, or a 15-ton road roller, 6 tons on the front wheel, which is 4 feet wide, and 4.5 tons on each of the rear wheels, each 20 inches wide.

*Street Railway Track.*—When the bridge is to carry a street railway, the load of a car weighing 50 tons on four axles spaced 5, 14, and 5 feet apart may be assumed as a probable maximum load. This load may be considered as distributed over an area of bridge floor about 35 feet in length and 10 feet in width, giving a maximum uniform load of about 300 pounds per square foot.

For light traffic roads, a car weighing 35 tons on the same wheel distribution may be used, giving a uniform loading of about 200 pounds per square foot.

**150. Distribution of Concentrated Loads.**—Investigations of the distribution of concentrated loads upon slabs have been made by Mr. Goldbeck for the U. S. Office of Public Roads. These tests<sup>1</sup> seemed to indicate that for a slab whose width is greater than its span, the effective width of distribution of a concentrated load might be taken at about eight-tenths of the span.

From a series of tests at the University of Illinois, Mr. Slater concluded<sup>2</sup> that for a slab whose width is greater than twice the span, the effective width ( $e$ ) might be assumed as  $e = \frac{4}{3}x + d$ , where  $x$  is the distance from the concentrated load to the nearest support and  $d$  is the width over which the load is applied. As the ratio of width to span decreases, the effective width becomes less, the coefficient in the formula becoming about 1.2 when the span equals the width.

From tests for the Highway Department of the State of Ohio<sup>3</sup> Professor Morris recommends for a concentrated load applied to the concrete floor of a highway bridge that  $e = 0.6S + 1.7$ , where  $e$  is the effective width in feet for a slab whose width is greater than its span, and  $S$  is the clear span in feet. This agrees well with the results of Mr. Slater if the load be placed at the middle of the span ( $x = S/2$ ).

When the load comes upon the floor of the bridge through a pavement or fill, it may also be considered as distributed lengthwise over a certain area. For earth fill, the length of distribution may be taken as twice the depth of fill. For gravel or macadam road surface, three or four times the depth of surface may be used.

In T-beam construction, when a slab is continuous over several girders and a load comes upon the slab immediately over one of the girders, the whole of the load will not be borne by the girder under the load, but a portion of it will be transferred by the slab to adjacent girders. In the Ohio tests mentioned above, this distribution was investigated and the following conclusions reached:

(1) The percentage of reinforcement has little or no effect upon the load distribution to the joists, so long as safe loads on the slab are not exceeded.

(2) The amount of load distributed by the slab to other joists than

<sup>1</sup> Proceedings, American Society for Testing Materials, 1915, p. 858.

<sup>2</sup> Proceedings, American Society for Testing Materials, 1913, p. 874.

<sup>3</sup> Bulletin No. 28, Ohio State Highway Department, 1915.

the one immediately under the load, increases with the thickness of the slab.

(3) The outside joists should be designed for the same live load as the intermediate joists.

(4) The axle load of a truck may be considered as distributed uniformly over 12 feet of roadway.

**151. Railway Bridges.**—For short spans, railway moving loads may be considered as uniformly distributed by the track and ballast. If the heaviest locomotive load per foot of length be distributed over a width of about 10 feet, the result will be well on the safe side. When the bridge is covered by a fill under the tracks, the width of distribution may be increased by twice the depth of fill.

The weights for maximum locomotive loads may vary from about 8000 to 10,000 pounds per linear foot of track, or from 800 to 1000 pounds per square foot when distributed over a width of 10 feet. For bridges longer than about 35 feet, it may be preferable to use actual locomotive wheel loads, or to somewhat reduce the load per square foot.

**ART. 42. DESIGN OF BEAM BRIDGES**

**152. Slab Bridges.**—When the span of a bridge is not more than 12 to 15 feet, the simple slab spanning the opening and resting upon the abutments at its ends is usually the most economical form to use. Under heavy loading, the economic limit of length may be only 10 to 12 feet, while for lighter loads, slabs 16 to 20 feet in length may be desirable. The design of a bridge slab will be illustrated by a numerical example.

*Example 1.*—Design a highway slab of 11 feet clear span, and width of 18 feet to carry a macadam road with the loading given in Section 149.

*Solution.*—

Assume weight of road material = 80 pounds per square foot.

Weight of slab = 145 pounds per square foot.

---

Total dead load = 225 pounds per square foot.

Live load is auto truck with 14,000 pounds on each of two wheels 6 feet apart. From Section 150, effective width,  $e = .6S + 1.7$ . As  $.6S$  is more than the distance apart of wheels, the loads would overlap, and we consider both loads distributed over  $e = .6S + 1.7 + 6 = 14.3$  feet. The live load per foot of width is  $28000/14.3 = 1950$  pounds. This load may be considered as applied over a length of



1.7 feet = 20 inches. The effective length of the beam is distance between centers of bearings, or 1 foot more than the clear span. (11 + 1 = 12 feet.)

Bending moments,

$$M \text{ (live)} = 1950/2 (72 - 5) = 65325 \text{ in.-lb.}$$

$$M \text{ (impact)} = 25 \text{ per cent of live} = 16330 \text{ in.-lb.}$$

$$M \text{ (dead)} = 225 \times 12 \times 12 \times 12/8 = 48600 \text{ in.-lb.}$$

$$\text{Total moment, } M = 130255 \text{ in.-lb.}$$

Taking  $f_c = 650$ ,  $f_s = 16,000$ ,  $n = 15$ , Table VII (p. 163) gives  $R = 108$ ,  $p = .0078$ ,  $j = .874$ .  $12d^2 = 13025/108 = 1206$ , and  $d = 10$  inches.

*Maximum shear* occurs when center of live load is 1.7/2 feet from support, in which case,

$$V \text{ (live)} = 1950 \times 10.65/12 = 1722 \text{ pounds.}$$

$$V \text{ (impact)} = 25 \text{ per cent of live} = 430 \text{ pounds.}$$

$$V \text{ (dead)} = 225 \times 11/2 = 1238 \text{ pounds.}$$

$$\text{Total shear } V = 3390 \text{ pounds.}$$

Depth required for shear,

$$d = \frac{V}{bjv} = \frac{3390}{12 \times .874 \times 40} = 8.1 \text{ inches.}$$

Make  $d = 10$  inches, then allowing concrete to extend 1.5 inches below steel, weight of beam is  $12 \times 11.5 \times 150/144 = 144$  pounds per square foot, which is within the assumed weight.

*Reinforcement.*—The area of steel required per foot of width,  $A = pbd = .0078 \times 12 \times 10 = .936 \text{ in.}^2$  From Table XV (p. 199), we see that  $\frac{3}{4}$ -inch round bars spaced 5.5 inches apart, or  $\frac{5}{8}$ -inch square bars 5 inches apart will answer. For the latter the maximum unit bond stress is

$$u = \frac{V}{jd\Sigma o} = \frac{3390}{.875 \times 10 \times 4 \times \frac{5}{8} \times \frac{1}{5}} = 65 \text{ lb./in.}^2$$

Fig. 80 shows the slab in longitudinal section. For lateral reinforcement  $\frac{1}{2}$ -inch round bars, 12 inches apart, are used. To prevent cracking due to negative moment where the slab joins the abutments,  $\frac{1}{2}$ -inch round bars 12 inches apart are placed in the ends of the slab at the top. Expansion joints, usually tar paper, are often placed on the top of the abutment under the slab, thus preventing the development of negative moment and allowing for temperature changes.

**153. T-Beam Bridges.**—When the length of the bridge is too great for a simple slab, it is found economical to use girders to support the slab. If the head room is sufficient and the span not too great, T-beam construction may be used. This consists of a series of T-beams extending from abutment to abutment, girders being placed under the

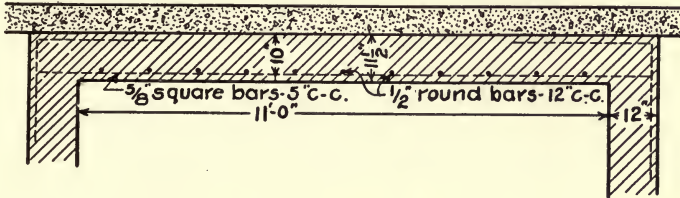

FIG. 80.—Slab Bridge.

slab to form the stems of the T-beams, and the slab being continuous over the girders for the width of the bridge.

*Example 2.*—Design a T-beam highway bridge with clear span of 24 feet, to carry a roadway 18 feet wide, using loadings as in Example 1.

*Solution.*—Allowing 12 inches for width of base of guard rail, the full width is 20 feet. Use five girders, spaced 4 feet on centers, the outside girders being 2 feet from end of beam (see Fig. 81).

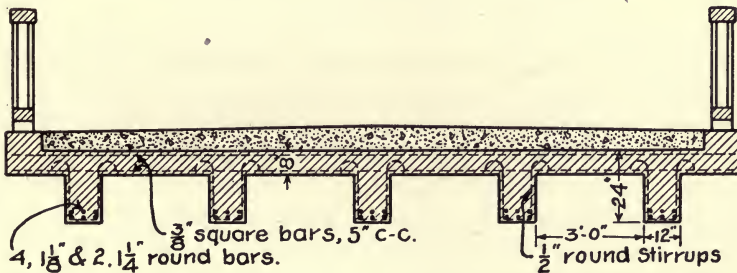

FIG. 81.—T-beam Girder Highway Bridge.

*Slab.*—Weight of road material = 80 pounds per square foot.  
 Assume weight of slab = 100 pounds per square foot.  
 Total dead load = 180 pounds per square foot.

The live load is a single wheel load of 14,000 pounds distributed over a width  $.6 \times 4 + 1.7 = 4.1$  feet. The live load per foot of width is  $14000/4.1 = 3415$  pounds. This may be considered as distributed

over 2 feet of length. The slab is continuous and taking the moment of the concentrated load as four-fifths of the moment for a simply supported beam, we have

$$M \text{ (live)} = (3415/2)(24-6)\frac{4}{5} = 24588 \text{ in.-lb.}$$

$$M \text{ (impact)} = 25 \text{ per cent of } 24588 = 6147 \text{ in.-lb.}$$

$$M \text{ (dead)} = 180 \times 4 \times 4 \times 12/12 = 2880 \text{ in.-lb.}$$

$$\text{Maximum moment, } M = 33615 \text{ in.-lb.}$$

$12 d^2 = 33615/108 = 311$ , and  $d = 5.1$  inches.

The shear is a maximum when the load is placed next to the support, and assuming width of girder at 12 inches,

$$V \text{ (live)} = 3415 \times 2.5/4 = 2134 \text{ pounds.}$$

$$V \text{ (impact)} = 25 \text{ per cent of } 3415 = 533 \text{ pounds.}$$

$$V \text{ (dead)} = 180 \times 3/2 = 270 \text{ pounds.}$$

$$\text{Total shear, } V = 2937 \text{ pounds.}$$

and the depth required for shear is

$$d = \frac{V}{bjv} = \frac{2967}{12 \times .874 \times 40} = 7.0 \text{ inches.}$$

Using  $d = 7.0$  inches,

$$A = \frac{M}{f_s j d} = \frac{33615}{16000 \times .875 \times 7} = 0.34 \text{ in.}^2$$

From Table XV (p. 199),  $\frac{3}{8}$ -inch square bars spaced 5 inches apart will answer.

When the concentrated load is at the middle of a span, adjacent unloaded spans will be under negative moment throughout their lengths. Maximum negative moment is approximately the same as positive moment, and  $\frac{3}{8}$ -inch square bars 5 inches apart will therefore be put through the top as well as the bottom of the slab.

With concrete extending 1 inch below the steel, the total depth of slab is 8 inches and the weight of slab  $= 8 \times 150/12 = 100$  pounds per square foot as assumed.

*Girders.*—The maximum stresses in the girder occur when a pair of wheels are directly over the girder. A portion of this load is distributed by the slab to adjacent girders. This rolling load consists of one wheel carrying 14,000 pounds and one carrying 6000 pounds, 12 feet apart. Assuming this distributed over a width of 6 feet (see Section 150), the load carried by one girder covers 4 feet of width and the loads are  $14000 \times 4/6 = 9333$  and  $6000 \times 4/6 = 4000$  pounds.



Assuming the stem of girder to weigh 250 pounds per foot, the dead load is  $180 \times 4 + 250 = 970$  pounds per linear foot of girder.

The position of moving load for maximum moment is that in which the heavier wheel is as far to one side of the middle of the beam as the center of gravity of the two loads is to the other, and the moment (taking length of beam as 25 feet) is:

$$M \text{ (live)} = \frac{13333(12.5 - 1.8)^2}{25} \times 12 = 732736 \text{ in.-lb.}$$

$$M \text{ (impact)} = 25 \text{ per cent of } 732736 = 183184 \text{ in.-lb.}$$

$$M \text{ (dead)} = 970 \times 25 \times 25 \times 12/8 = 909375 \text{ in.-lb.}$$

$$\text{Total moment, } M = 1825295 \text{ in.-lb.}$$

Maximum shear occurs when the heavier load is adjacent to the support, and the center of gravity of the loads (considering the loads distributed over 2 feet of length) is 5.1 feet from the center of support.

$$V \text{ (live)} = 13333(25 - 5.1)/25 = 10133 \text{ pounds}$$

$$V \text{ (impact)} = 25 \text{ per cent of } 10133 = 2533 \text{ pounds.}$$

$$V \text{ (dead)} = 970 \times 25/2 = 12125 \text{ pounds.}$$

$$\text{Total } V = 24791 \text{ pounds.}$$

The depth required for shear with 12-inch width of stem is

$$d = \frac{V}{b'jv} = \frac{24791}{12 \times .874 \times 120} = 19.7 \text{ inches.}$$

The girder is a T-beam with flange 48 inches wide and 8 inches thick, and stem 12 inches wide and 20 inches deep.

$$d/t = 20/8 = 2.5, \quad \text{and} \quad Q = \frac{M}{btd} = \frac{1825295}{48 \times 8 \times 20} = 238.$$

From Diagram I (p. 184), we see that the neutral axis is in the flange.

$$R = \frac{M}{bd^2} = \frac{1825295}{48 \times 20 \times 20} = 95.$$

From Table VII (p. 163), we see that for  $f_s = 16000$  and  $R = 95$ ,  $f_c = 600$  and  $p = .0068$ . Then  $A = .0068 \times 48 \times 20 = 6.53$  inches. From Table X (p. 166), it is found that four  $1\frac{3}{8}$ - and two  $1\frac{1}{4}$ -inch round bars will answer. These are placed in two rows, two  $1\frac{3}{8}$ - and one  $1\frac{1}{4}$ -inch bars in each row, making the total depth of the beam 24 inches. The weight of stem is then  $= 16 \times 12 \times 150/144 = 200$  pounds per foot, which is less than the assumed weight.

*Diagonal Tension.*—The maximum shear at the middle of the

girder occurs when the moving load is at one side of the middle of the beam, or  $V$  (middle) =  $9333 \times 11.5 \times 25 = 4293$  pounds; with impact this becomes 5366 pounds and  $v$  (middle) =  $\frac{5366}{12 \times .875 \times 20} = 25.5$  pounds. The maximum unit shear varies from 25.5 lb./in.<sup>2</sup> at the middle to 120 lb./in.<sup>2</sup> at the supports. Stirrups are necessary from the support to the point where the shear is 40 lb./in.<sup>2</sup> Using Formula 13 of Section 108, if U-shaped stirrups of  $\frac{1}{2}$ -inch round steel be used, the spacing at the ends should be

$$s = \frac{2A_v f_s}{vb'} = \frac{2 \times .39 \times 16000}{120 \times 12} = 8 \text{ inches.}$$

Use this spacing for eight stirrups, then change to 12 inches spacing and continue to middle of girder. Two of the horizontal rods may also be turned up near the abutment.

**154. Through Girder Bridges.**—For spans of considerable length, or where the head room under the roadway is too contracted to permit

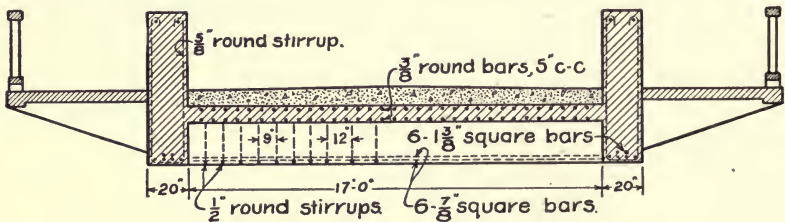

FIG. 82.—Through Girder Bridge.

the use of T-beam construction, through girders may be used at the sides of the roadway, the slab floor being hung from the bottoms of the side girders. The floors in such bridges may be simple slabs, extending from one girder to the other, or the floor slab may be carried by T-beams across the bridge from girder to girder.

Fig. 82 shows a bridge of this type. The method of design is the same as for the other types. If the loading of Example 2 be used, the T-beam cross-girder would carry the two loads of 14,000 pounds each, 6 feet apart, or if the width of the bridge and importance of traffic are sufficient, two passing trucks might give a loading of four such wheels spaced 6, 2, and 6 feet apart. In a bridge for heavy traffic, where passing loads might come upon it, each girder should be able to carry the whole weight of a truck as a rolling load in addition to the dead weight of one-half the bridge. On a country highway, designing for the passing of a single truck is usually sufficient, as the meeting

of two unusually heavy loads on the bridge is a very remote contingency.

When sidewalks are to be carried at the side of the roadway, the through girder may be placed between the roadway and sidewalk, and the sidewalk carried by cantilever beams attached to the girders. These cantilevers should be continuations of the cross-girders, the tension steel extending through the main girder and being anchored into the cross-girders.

*Example 3.*—Design the principal members for a bridge of 35 feet clear span, 17 feet wide between girders, to carry roadway and loads as in Example 2. Also to carry sidewalks 5 feet wide, loaded with 100 pounds per square foot.

*Solution.*—Assume the spacing of cross-girders at 4 feet c. to c. and the road slab as in Example 2; slab 8 inches thick,  $d=7$  inches,  $\frac{3}{8}$ -inch square steel 5 inches c. to c. top and bottom.

*Cross-beams.*—The dead load upon the T-beams, assuming weight of stem at 150 pounds per linear foot will be  $180 \times 4 + 150 = 870$  pounds per linear foot. The live load is composed of two 14,000 pounds wheel loads, 6 feet apart. As these are distributed over 6 feet of width,  $14000 \times 4/6 = 9333$  will be carried by the 4 feet width of beam.

The effective length of beam is 18 feet, and

$$M \text{ (live)} = \frac{18666(9 - 1.5)^2}{18} = 700000 \text{ in.-lb.}$$

$$M \text{ (impact)} = 25 \text{ per cent of } 700000 = 175000 \text{ in.-lb.}$$

$$M \text{ (dead)} = \frac{870 \times 18 \times 18 \times 12}{8} = 422820 \text{ in.-lb.}$$

$$\text{Total moment, } M = 1297820 \text{ in.-lb.}$$

Assuming that the nearest wheel load may pass 18 inches from the side girder, maximum shear in the cross-beam is

$$V \text{ (live)} = \frac{18666(18 - 5)}{18} = 13480 \text{ pounds.}$$

$$V \text{ (impact)} = 25 \text{ per cent} = 3370 \text{ pounds.}$$

$$V \text{ (dead)} = 870 \times 9 = 7830 \text{ pounds.}$$

$$\text{Total shear, } V = 24680 \text{ pounds.}$$

Assuming width of stem of T-beam to be 12 inches, we have the required depth,

$$d = \frac{V}{b'jv} = \frac{24680}{12 \times .875 \times 120} = 19.5 \text{ inches.}$$



By Table VII (p. 163), for  $f_s = 16000$  and

$$R = \frac{1297820}{48 \times 19.5 \times 19.5} = 71,$$

we find  $f_c = 500$  and  $p = .005$ . Then

$$A = pbd = .005 \times 48 \times 19.5 = 4.68 \text{ in.}^2$$

Use six  $\frac{7}{8}$ -inch square bars, four in lower row, two in upper.

The total depth of beam is 22 inches, and the weight of the stem is  $12 \times 14 \times 150 / 144 = 175$  pounds per linear foot, 25 pounds more than assumed.

Using U-shaped stirrups of  $\frac{1}{2}$ -inch round bars, the spacing at end of beam is

$$s = \frac{2 \times .39 \times 16000}{120 \times 12} = 9 \text{ inches.}$$

Place eight stirrups with this spacing then space 12 inches apart to middle of span.

The sidewalk slab carries 100 pounds per square foot moving load, on 4-foot continuous spans. We will make it 3 inches thick, reinforced with  $\frac{3}{8}$ -inch round bars 6 inches apart. The sidewalk supports are cantilever beams carrying 4 feet of sidewalk with its load and 4 feet of handrail at the end.

*Side Girders.*—The sidewalk with its load weighs about 800 pounds per foot of girder. One-half the weight of bridge floor and T-beams is 1900 pounds per foot. Assume weight of girder as 1600 pounds per foot, and the total dead load is 4300 pounds per linear foot.

The maximum moving load is the weight of a truck whose nearest wheels are 18 inches from the girder. These loads are

$$\frac{28000 \times (18 - 5)}{18} = 20200 \text{ and } \frac{12000 \times (18 - 5)}{18} = 8700 \text{ lb., 12 feet apart.}$$

Take effective length of girder as 36 feet and we have

$$M \text{ (live)} = \frac{28900(18 - 1.8)^2}{36} \times 12 = 2528200 \text{ in.-lb.}$$

$$M \text{ (impact)} - 25 \text{ per cent of } 2528200 = 632050 \text{ in.-lb.}$$

$$M \text{ (dead)} = \frac{4300 \times 36 \times 36}{8} \times 12 = 8359200 \text{ in.-lb.}$$

$$\text{Total } M = 11519450 \text{ in.-lb.}$$

$$bd^2 = \frac{11519450}{108} = 106666.$$

Assuming  $b = 20$  inches, we find  $d = 73$  inches.

$$A = pbd = .0078 \times 20 \times 73 = 11.38 \text{ in.}^2$$

Table X shows that nine  $1\frac{1}{8}$ -inch square bars may be used, or six  $1\frac{3}{8}$ -inch square bars will answer. These can be spaced four in the lower and two in upper row. The maximum bond stress for the latter is

$$u = \frac{V}{jd\sum o} = \frac{106250}{.875 \times 73 \times 33} = 50 \text{ lb./in.}^2$$

*Shear.*—Considering the live loads to be applied over a length of 2 feet,

$$V \text{ (live)} = 28900(36 - 5.1)/36 = 24800 \text{ pounds.}$$

$$V \text{ (impact)} = 25 \text{ per cent of } 24800 = 6200 \text{ pounds.}$$

$$V \text{ (dead)} = 4300 \times 17.5 = 75250 \text{ pounds.}$$

$$\text{Total } V = 106250 \text{ pounds.}$$

The maximum shear at the middle of the beam occurs when the heavier load is just past the middle point, or

$$V = 28900(18 - 4.6)/36 = 10760 \text{ pounds.}$$

and

$$v(\text{middle}) = \frac{10760}{20 \times .875 \times 73} = 9 \text{ lb./in.}^2$$

The maximum shear varies from 83 lb./in.<sup>2</sup> at the support to 9 lb./in.<sup>2</sup> at the middle of the girder. Reinforcement for diagonal tension is needed where  $v$  is more than 40 lb./in.<sup>2</sup> If U-shaped stirrups be spaced 12 inches apart, at the abutment,

$$A_s = \frac{bvs}{2f_s} = \frac{20 \times 83 \times 12}{2 \times 16000} = .62 \text{ in.}^2$$

By Table X,  $\frac{5}{8}$ -inch round bars are needed. The tops of these bars should be turned into hooks to secure ample bond. Seven stirrups will be used spaced 12 inches apart, three spaced 18 inches and two spaced 30 inches, at each end of the girder.

*Hangers.*—To prevent the T-beams breaking loose from the girders, bars passing under the steel in the stem of the T-beam, and extending up into the girder are used to carry the reactions at the ends of the T-beams. These reactions equal the maximum shear upon the T-beams, and the area of steel required is  $A_h = 24245/16000 = 1.52 \text{ in.}^2$  By Table X, we find 1-inch round bars to be needed. These should extend upward a distance sufficient to develop a bond strength equal to the tensile strength of the bars, or at least 50 diameters.

## CHAPTER X

### MASONRY ARCHES

#### ART. 43. VOUSOIR ARCHES

**155. Definitions.**—A masonry arch is a structure of masonry spanning an opening and carrying its loads as longitudinal thrust, which exert outward as well as vertical thrusts upon the abutments. A *voussoir arch* is one in which the arch ring is composed of a number of independent blocks of stone or masonry.

*Parts of an Arch.*—The principal parts of an arch are as follows:

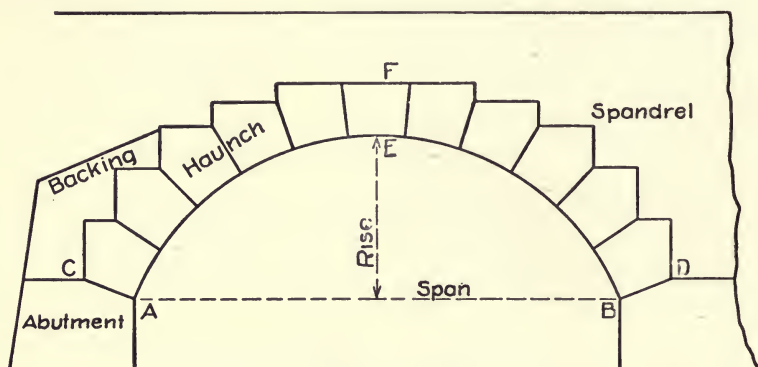

FIG. 83.

The under or concave surface of an arch is called the *soffit*. The outer or convex surface is the *back*.

The *crown* is the highest part of the arch ring ( $E-F$ , Fig. 82).

The *skewbacks* are the joints at the ends of the arch where it rests upon the abutments ( $C-A$ ,  $B-D$ , Fig. 83).

The *intrados* is the intersection of the soffit with a vertical plane perpendicular to the axis of the arch ( $A-E-B$ , Fig. 83).

The *extrados* is the intersection of the outer surface with a vertical plane perpendicular to the axis ( $C-F-D$ , Fig. 83).

The *springing lines* are the intersections of the skewbacks with the soffit.



The *span* is the distance between springing lines.

The *rise* is the perpendicular distance from the highest point of the intrados to the plane of the springing lines.

The *voussoirs* are the wedge-shaped stones of which an arch is composed.

The *keystone* is the voussoir at the crown of the arch ( $E-F$ ).

The *springers* are the voussoirs next the skewbacks.

The *haunch* is the portion of the arch between the keystone and springers.

The *arch ring* is the whole set of voussoirs from skewback to skewback.

The *ring stones* are voussoirs showing on the face of the arch.

The *arch sheeting* is the portion of the arch ring not showing at the ends.

*Backing* is masonry above and outside the arch ring.

The *spandrel* is the space between the back of the arch and the roadway above. The walls above the ring stones at the ends of the arch are spandrel walls and the filling between these walls is spandrel filling.

*Kinds of Arches.*—A *full-centered arch* is one whose intrados is a semicircle. A *segmental arch* is a circular arch whose intrados is less than a semicircle. A *pointed arch* has an intrados composed of two circular arcs which intersect at the crown. A three-centered arch composed of arcs tangent to each other is sometimes called a *basket-handled arch*.

A *right arch* is one whose ends are perpendicular to its axis. An arch whose ends are oblique to its axis is called a *skew arch*.

*Hinged arches* are those in which hinged joints are used at crown and skewback. Those without hinges are called *solid arches*.

**156. Theory of Stability.**—A voussoir arch is supposed to be composed of a number of independent blocks in contact with each other and held in place by the pressures between them. In Fig. 84, let  $ABCD$  represent a voussoir at any part of an arch ring. If  $P$  is the pressure received from the voussoir above and  $W$  the external load carried by the voussoir, the resultant,  $R$ , of these forces will be the pressure transmitted to the voussoir below. If the line of action of this resultant should pass outside of the joint  $A-D$ , the arch will fail by the voussoir rotating about the edge of the joint.

If the point of application of  $R$  is outside the middle third of

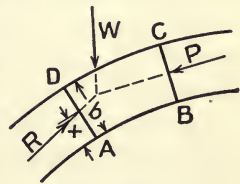

FIG. 84.

$A-D$ , there will be a tendency for the joint to open on the opposite side, and the area of contact between the voussoirs will be reduced. If the line of action of  $R$  makes an angle with the normal to the joint  $A-D$  greater than the angle of friction for the surfaces upon each other, the voussoirs may slide upon each other, causing failure of the arch.

For stability of the arch:

(1) The resultant pressures between voussoirs should act within the middle third of the joints.

(2) The components of the resultant pressures parallel to the joints ( $R \sin \alpha$ ) should be less than the frictional resistance of the voussoirs to sliding upon each other.

(3) The unit pressures at the surfaces of contact should be less than the safe compressive strength of the material of the voussoirs.

If  $b$  represents the width of the joint  $AD$ ,  $x$  the distance of the point of application of  $R$  from the nearest edge and  $\alpha$  the angle made by  $R$  with the normal to the joint, the maximum unit compression will be represented by

$$f_c = \frac{R(4b - 6x)}{b^2} \cos \alpha. \quad (\text{See Section 126.})$$

Usually the angle  $\alpha$  is so small that  $\cos \alpha$  may be taken as 1 without sensible error, or  $R$  may be considered as equal to its normal component.

*Line of Pressure.*—If an arch ring be divided into a number of voussoirs, and the points of application of the resultant pressures upon the joints between these voussoirs be determined, the broken or curved line joining these points of application is known as the line of pressure for the arch. In Fig. 85 the line  $abcdef$  is called the line of pressure for the half arch, when  $H$  is the crown thrust and  $P_1, P_2$ , etc., are the external loads coming upon the several divisions. The true line of pressure, or of resistance, is a curve circumscribing the polygon  $abcdef$ . The larger the number of divisions of the arch ring, the more nearly will the polygon approach this curve.

In determining the line of pressure, the arch ring is divided into a convenient number of parts, usually six to sixteen on each side of the crown, and the external loads ( $p_1-p_5$ , Fig. 85) coming upon the various divisions are found. It is now necessary to know certain points through which the line of pressure must pass in order to draw it. If the arch be hinged, the line of pressure must pass through the centers of the hinges and may be drawn without difficulty. In a solid arch, the points of application of the pressures upon the various joints are

not definitely known, and certain assumptions must be made concerning them. Any number of different lines may be drawn as these assumptions are varied.

*Hypotheses for Line of Pressure.*—If Fig. 85 represent half of a symmetrically loaded arch, the crown pressure  $H$  will be horizontal. Assuming its point of application,  $a$ , and that its line of resistance passes through a definite point on one of the other joints as  $f$ , the amount of  $H$  may be found by taking a center of moments at  $f$  and writing the moment equation for all the loads upon the half arch equal to zero.  $H$  is then known in amount, direction and point of application and the line of pressure may be drawn, as shown.

Several hypotheses have been proposed for the purpose of fixing the position of the line of thrust. Professor Durand-Claye assumed

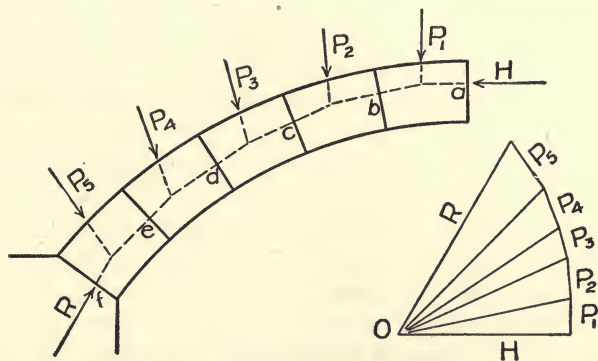

FIG. 85.

that the true line of resistance is that which gives the smallest absolute pressure upon any joint. This method is outlined in Van Nostrand's *Engineering Magazine*, Vol. XV, p. 33. Professor Winkler suggested that "for an arch ring of constant cross-section, that line of resistance is approximately the true one which lies nearest to the axis of the arch ring, as determined by the method of least squares." No practicable method of applying this principle to ordinary cases of voussour arches has been devised. Moseley's hypothesis was that the true-line of resistance is that for which the thrust at the crown is the least consistent with stability. This occurs (Fig. 85) when  $H$  is at the highest and  $R$  at the lowest point it can occupy on the joint. This hypothesis is the basis of Scheffler's method of drawing the line of resistance.

*Scheffler's theory* assumes that  $H$  is applied at the upper edge of the middle third of the crown joint, and that the value of  $H$  is such as



to cause the line of pressure to touch the lower edge of the middle third at one of the joints (as *d*, *e*, or *f*) nearer the abutment. The joint at which the line of pressure is tangent to the lower edge of the middle third is known as the joint of rupture. The joint of rupture may be found by taking moments about the lower edge of the middle third of each of several joints and solving for *H*. All loads acting between the joint considered and the crown should be used in obtaining the moment, and the one giving the largest value of *H* is the joint of rupture. The value of *H* so determined is the least consistent with stability, as a less value causes the line of pressure to pass outside the middle third at the joint of rupture.

Should it be found that the line of pressure passes outside the middle third on the upper side of any of the joints between the joint of rupture and the crown, the point of application of *H* may be lowered without violating the hypothesis. This leads to the usual statement that "if any line of pressure can be drawn within the middle third of the arch ring the arch will be stable." This is justified by common experience.

When the loading upon the arch is not symmetrical, this method of finding the crown thrust cannot be used, and in this case it is usual to select three points through which to pass the line of pressure, one at the crown and one near each abutment. A line of pressure is then passed through these three points, and if the line so found does not remain within the middle third of the arch ring the positions of the points may be changed and new lines constructed. This may be repeated until it is determined whether any line of pressure can be drawn within the middle third.

#### ART. 44. LOADS FOR MASONRY ARCHES

**157. Live Loads for Highway Bridges.**—For the floors of open spandrel arch bridges, live loads should be considered in the same manner as for slab bridges (see Art. 41). In investigations of arch rings, live loads are usually taken as uniformly distributed. The loading which should be used in any design depends upon the location of the bridge, the character of traffic, and the length of span.

A heavy (20-ton) motor truck may bring a load of about 140 pounds per square foot upon a bridge of short span (about 40 feet). Bridges 60 to 100 feet span subjected to traffic of motor trucks and heavily loaded wagons may be considered to carry about 100 pounds per square foot. For longer bridges this load may be lessened, bridges over 200 feet being designed for about 75 pounds per square foot.

For bridges less than 100 feet in length carrying street railways, a load of 1800 pounds per foot of length for each track may be taken. For spans of 200 feet or more, this may be reduced to 1200 pounds per foot of track. These loads are considered as distributed over a width of about 9 feet, giving loads of 200 and 133 pounds per square foot respectively. For spans between 100 and 200 feet, the loads may vary according to the length of span.

For light traffic lines on country roads, a load of 1200 pounds per foot of track may be used for arches less than 100 feet in length and 1000 pounds per foot for those 200 feet or more in length. Frequently bridges must be built for special service, or where the traffic conditions are unusual and should be designed for any loads that may reasonably be expected to come upon them. Traffic conditions are constantly undergoing important changes, and in determining the loading to be used in any particular instance, it is desirable to consider the possible effect upon future traffic of the rapid increase in the use of heavy auto-trucks and traction engines. As masonry arches are structures of permanent character, the probable future development of traffic should be considered and liberal loadings used in design.

**158. Live Loads for Railway Arches.**—Standard locomotive loadings are used in the design of floor systems for open spandrel arches, as in beam bridges, and are also sometimes employed in investigations of arch rings. Equivalent uniform loadings may, however, commonly be used in arch-ring design.

Loadings should correspond with the heaviest locomotive and train loads to be expected. For spans less than about 60 feet, a load of 8000 pounds per foot of track, or 1000 pounds per square foot of road surface is frequently used. When the span is 80 feet or more a load of 5600 pounds per foot of track, or about 700 pounds per square foot, is used, which are approximately the same as Cooper's E 40 loading. Impact is not taken into account in the arch-ring investigation.

A concentrated load upon a fill may be considered as distributed downward through the fill at an angle of  $45^\circ$  with the vertical, the top of the distributing slope being taken from the ends of the ties. Wheel loads are taken as distributed over three ties and then transmitted to the filling.

**159. Dead Loads.**—In arch bridges, the dead weights of the arch ring and of the filling or structure above constitute the principal loads upon the arch rings. The live loads are much less in amount, and are important mainly as producing unsymmetrical loading when

the load does not extend over the whole arch. In computing the dead load upon an arch ring, the actual weights of the materials to be used should be taken when they are accurately known. It is common to assume the weight of earth filling as 100 pounds per cubic foot, and that of concrete of other masonry as 150 pounds per cubic foot.

In open-spandrel arches the dead weights act vertically through the columns or walls supporting the floor of the roadway, and may be readily computed. When the spandrels are filled with earth, each section of the arch ring is assumed to carry the weight of the filling and roadway vertically above it.

The earth pressures upon the inclined back of the arch ring are not actually vertical, but may have certain horizontal components. For arches of small rise, these horizontal pressures are small and may be neglected, but when the rise of the arch is large, the horizontal earth thrusts may be considerable, and should be taken into account, although their omission is usually an error on the safe side. While the amount of horizontal earth pressure cannot be exactly determined, it is usual to use Rankine's minimum value for unit horizontal earth pressure in terms of the unit vertical pressure, which is

$$H = V \frac{1 - \sin \phi}{1 + \sin \phi},$$

in which  $H$  is the horizontal and  $V$  the vertical unit pressure, and  $\phi$  the angle of friction for the earth. For ordinary earth filling, this would make the unit horizontal pressure at any point approximately one-fourth of the unit vertical pressure at the same point, the probability being that a horizontal pressure of at least this amount may always be developed.

The methods used for determining pressures upon retaining walls evidently are not applicable to this case. The actual horizontal earth pressure may vary within rather wide limits, and cannot be accurately determined. In retaining-wall design, the maximum earth thrust which may come against the wall is computed, while for the arch we need to know the minimum horizontal pressure which may be relied upon to help sustain the arch. That the actual pressure may sometimes be considerably more than the computed minimum is quite probable.

When an arch carries a continuous masonry wall, as in an opening through the wall of a building, or the spandrel wall at the end of an arch bridge, the wall itself would arch over the opening and be capable of self-support if the arch were removed. The load upon the



arch would therefore be only that due to a triangular piece of wall immediately above the arch as in the case of a stone lintel. (See Section 53.)

#### ART. 45. DESIGN OF VOUSSOIR ARCHES

**160. Methods of Design.**—In designing masonry arches, the form and dimensions of the arch ring are first assumed and the stability of the arch, as assumed, is then investigated. The graphical method of investigation is commonly employed, a line of pressure (see Section 156) being drawn and the maximum unit compression computed. Stability requires that the line of pressure remain within the middle third of the arch ring and that the unit compression does not exceed a safe value. If the first assumptions are not satisfactory the shape or dimensions of the arch ring may be modified and the new assumptions tested as before.

Arches subjected to the action of moving loads should be tested for conditions of partial loading, which may cause unsymmetrical distortion of arch ring, as well as for full load over the whole arch. For ordinary loadings and spans of moderate length, it is usually sufficient to draw the line of pressure for arch fully loaded and with live load extending over half the arch, but in large and important structures, or those with unusual loadings, it may be desirable to test the arch ring with live loads in other positions which seem likely to produce maximum distortions of the line of pressure.

**161. Thickness of Arch Masonry.**—The choice of dimensions for the trial arch ring is necessarily based upon judgment founded upon knowledge of the dimensions of existing arches, which are found to differ widely, and rules have been formulated by several authorities for the purpose of aiding in selecting the dimensions.

*Crown Thickness.*—Several different formulas have been proposed for determining the thickness at the crown. *Trautwine's formula* for the depth of keystone of first-class cut-stone arches, whether circular or elliptical, is

$$\text{Depth of key in feet} = \frac{\sqrt{\text{Radius} + \text{half span}}}{4} + .2 \text{ foot.}$$

For second-class work this depth may be increased about one-eighth part; or for brick or rubble about one-third.

*Rankine's formula* for the depth of keystone for a single arch is

$$\text{Depth in feet} = \sqrt{.12 \text{ radius.}}$$

This gives results which agree fairly well with Trautwine's formula. For an arch of a series, Rankine also recommends

$$\text{Depth in feet} = \sqrt{.17 \text{ radius.}}$$

These formulas make the thickness depend upon the span and rise of the arch without regard to the loading. They agree fairly well with many examples of existing arches, but make the thickness rather large for arches of moderate span.

*Douglas Formulas.*—In Merriman's American Civil Engineer's Pocket Book, Mr. Walter J. Douglas gives the following rules for thickness at crown:

#### THICKNESS IN FEET AT CROWN FOR HIGHWAY ARCHES

| Kind of Masonry.                          | SPAN IN FEET = $L$ . |                 |                        |                 |
|---|----------------------|-----------------|------------------------|-----------------|
|   | Under 20.            | 20 to 50.       | 50 to 150.             | Over 150.       |
| First-class ashlar . . . . .              | $0.04(6 + L)$        | $0.020(30 + L)$ | $0.00012(11000 + L^2)$ | $0.018(75 + L)$ |
| Second-class ashlar<br>or brick . . . . . | $0.06(6 + L)$        | $0.025(30 + L)$ | $0.00016(11000 + L^2)$ | $0.025(75 + L)$ |
| Plain concrete . . . . .                  | $0.04(6 + L)$        | $0.020(30 + L)$ | $0.00014(11000 + L^2)$ | $0.020(75 + L)$ |
| Reinforced concrete . . . . .             | $0.03(6 + L)$        | $0.015(30 + L)$ | $0.00010(11000 + L^2)$ | $0.016(75 + L)$ |

For railroad arches, add 25 per cent for arches 20- to 50-foot span, 20 per cent for 50 to 150 feet, and 15 per cent for those over 150 feet.

These formulas give smaller thickness for highway arches of short span than Trautwine's and do not vary the thickness with the rise of the arch.

*Thickness at Skewback.*—If the arch ring be made of uniform thickness, the unit pressure at the ends will be greater than at the crown. The pressure may often be made fairly uniform by making the thickness at any radial joint equal to the crown thickness times the secant of the angle made by the joint with the vertical.

In the American Civil Engineer's Pocket Book, Mr. Douglas recommends that the thickness at the springing line of a masonry arch be obtained by adding the following percentages to the crown thickness:

- (1) Add 50 per cent for circular, parabolic, and catenarian arches having a ratio of rise to span less than one-quarter.
- (2) Add 100 per cent for circular, parabolic, catenarian, and three-centered arches having a ratio of rise to span greater than one-quarter.
- (3) Add 150 per cent for elliptical, five-centered and seven-centered arches.

Mr. Douglas recommends that the top thickness of abutments be assumed at five times the crown thickness. For a pier between

arches in a series he suggests a thickness at top of three and one-half times the crown thickness, but places an abutment at every third or fifth span.

Trautwine gives a method for design of abutment, approximately as follows (see Fig. 86):

Thickness at springing line in feet

$$a-b = \frac{\text{Radius}}{5} + \frac{\text{Rise}}{10} + 2 \text{ feet.}$$

Lay off  $a-c = \text{rise}$ , and  $c-d = ab + \frac{\text{span}}{24}$ .

Continue  $bd$  downward to bottom of abutment, and upward a distance  $be = \text{rise}/2$ . From  $e$  draw a tangent  $e-f$  to the extrados.

It is also required that the thickness at bottom of abutment  $gh$ , shall not be less than two-thirds of the height  $ag$ .

If the abutment is of rough rubble, 6 inches is added to the thickness to insure full thickness in every part.

These rules usually give arches which are amply strong

for heavy railway service and heavier than necessary for highway bridges. For structures of small span, however, when voussoir or plain concrete arches are used, the saving effected by paring them down is small, and rather heavy work is common practice.

**162. Investigation of Stability.**—After assuming dimensions for the arch ring and abutments, the stability of the arch is investigated by the methods outlined in Section 156. The stability of the abutment is tested by continuing the line of thrust and determining whether it cuts the base of the abutment within the middle third. The sufficiency of the foundation for the abutment must also be examined and footings provided which will properly distribute the pressure over the soil upon which it is to be placed. The following example will outline the method of procedure.

*Example.*—A highway arch is to have a span of 40 feet and a rise of 10 feet. It is to carry a moving load of 200 pounds per square foot.

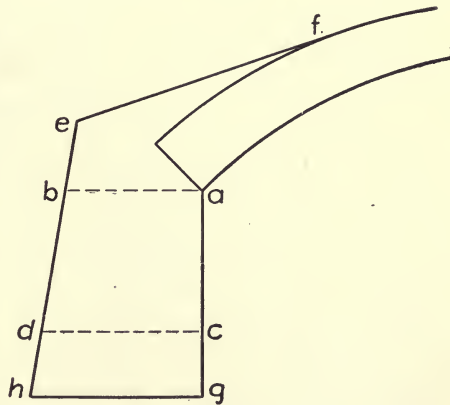

FIG. 86.



The depth of fill at crown is 2 feet. The weight of earth fill is 100 and of masonry 150 pounds per cubic foot.

We will try a segmental arch. By the Douglas rule, the thickness at crown would be 1.4 feet. By Trautwine's formula, it would be 1.95 feet. Make the crown thickness 18 inches. By the Douglas rule the thickness at springing would be between 1.5 and 2 times the crown thickness. We will try 30 inches. Draw the arch ring as shown in Fig. 87, and divide it into equal parts by radial lines. The line  $z-t$  represents the roadway and verticals from the points where the radial divisions cut the extrados divide the earth fill into parts resting upon the sections of the arch ring. These loads, including the weights of the sections of arch ring, are now computed, and their vertical lines of action determined.

In finding the loads, it is often convenient to draw the *reduced load contour*, which is obtained by reducing the height of the sections so that the volume contained by them may be considered to weigh the same per unit as the arch ring. Thus if the earth fill weighs 100 pounds and masonry 150 pounds per cubic foot, the height  $ax$  is made two-thirds of  $az$ , and the other verticals are reduced proportionately, giving the volume  $a-x-u-g$ , which has the same weight at 150 pounds as the earth fill at 100 pounds. In the same way  $x-y-v-u$  represents the live load which would come upon half the arch ring reduced to 150 pounds per cubic foot. In the example, the loadings given represent live load extending over the left half of the arch, dead load only upon the right half.

The *horizontal thrusts* against the arch ring are sometimes computed by assuming that the unit horizontal thrust bears a definite proportion (usually about one-quarter) to the unit vertical thrust. Thus in Fig. 87, if the vertical load upon the section  $a-b$  is 5085 pounds the horizontal component of the load on the section is

$$\frac{5085}{4} \times \frac{ap}{pb} = 1550 \text{ pounds.}$$

In the example, the horizontal components upon the two lower divisions on each side are used, those upon the upper divisions being too small to affect the results appreciably. The horizontal components of the loads are not usually considered in a problem of this kind unless the rise of the arch is large as compared with the span.

Having computed the loads, a line of pressure may now be drawn through any three points in the arch ring. Assume that it is to pass through the lower third point of the joint  $a$  on the loaded side, the

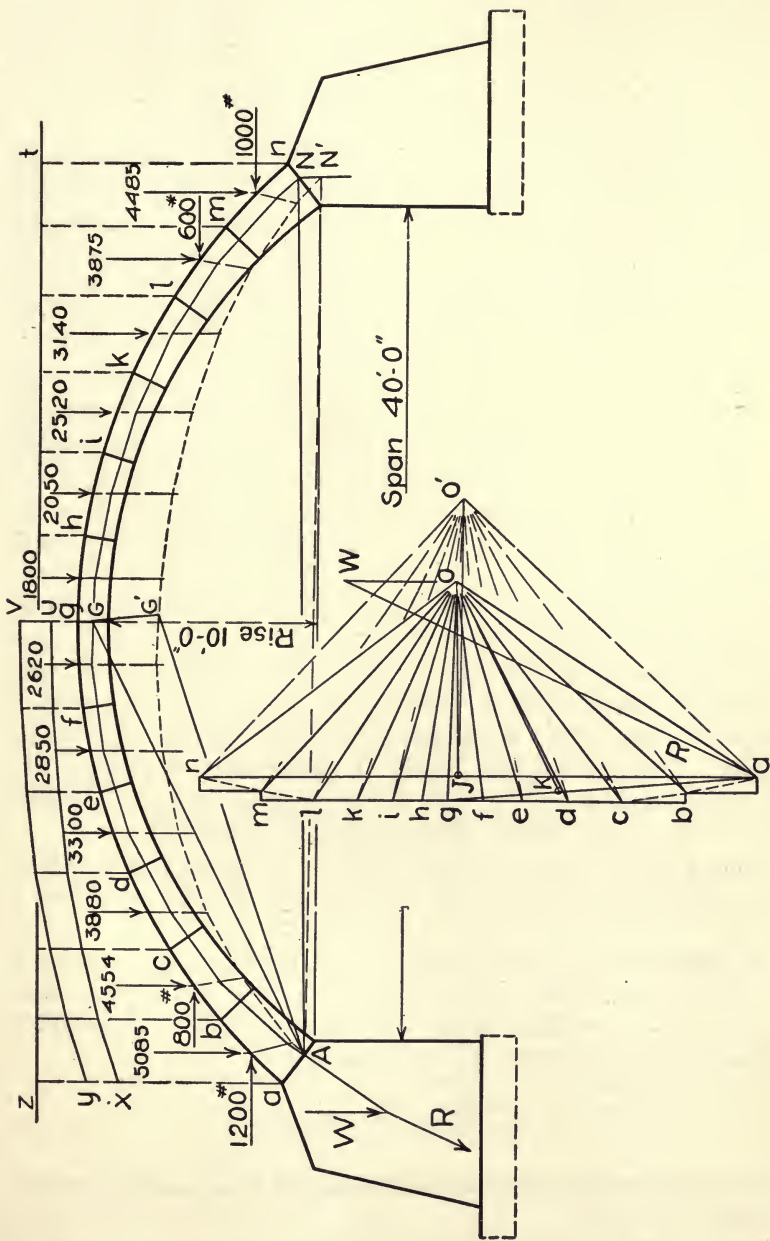

FIG. 87.

middle point at the crown, and the upper third point at the joint  $n$  on the unloaded side.

The load line is first plotted on a convenient scale by laying off the loads which come upon the various sections in succession,  $n-m$ ,  $m-l$ , etc.;  $n-a$  is now the resultant of all the loads upon the arch ring. A pole  $O'$  is assumed and the strings  $O'a$ ,  $O'b$ , etc., drawn.

The equilibrium polygon, shown in broken lines, may now be drawn. Starting from  $A$ , the lower third point on joint  $a$ , with a line parallel to the string  $O'a$  to an intersection with the line of action of the load upon the section  $a-b$ . From this intersection, draw a line parallel to  $O'b$  to intersection with the line of action of the load on  $b-c$ , and continue it until a parallel to  $O'n$  is intersected in  $N'$  upon a line through  $N$  parallel to the resultant  $n-a$ .

Connect  $N'$  with  $A$ , and from  $O'$  draw a line parallel to  $N'-A$  to intersection  $J$  with the resultant  $n-a$  of the loads, thus dividing the resultant into two reactions,  $n-J$  and  $J-a$ , which would exist at the ends of the span if the horizontal thrust of the arch be neglected. Join the points  $A$  and  $N$  and from  $J$  draw a line parallel to  $A-N$ . A pole lying upon this line will give an equilibrium polygon passing through  $A$  and  $N$ .

The distance of the pole from  $J$  must now be determined to cause the equilibrium polygon to pass through the middle of the crown joint. The line  $g-a$  in the force polygon, is the resultant of the loads upon the left half of the arch. From the middle of the crown section, draw  $G-G'$ , parallel to  $g-a$ , to intersection with the trial equilibrium polygon. Connect  $A-G'$  and  $A-G$ . From  $O'$  draw  $O'k$  parallel to  $G'A$  to intersection with  $g-a$  in  $k$ , and from  $k$  draw  $k-O$  parallel to  $AG$ . The point  $O$  where  $KO$  intersects  $JO$  is the new pole.

From  $A$ , the new line of thrust may now be drawn with sides parallel to the strings,  $Oa$ ,  $Ob$ , etc. This passes through the points  $G$  and  $N$ .

By inspection we see that the line of thrust, as thus drawn, is everywhere within the middle of the arch ring. The thrust upon the joint at  $a$  is represented by the length of the line  $O-a=27000$  pounds, and the maximum unit compression is

$$f_c = \frac{27000}{30 \times 12} \times 2 = 150 \text{ lb./in.}^2$$

The unit compression upon any other joint may be found in the same manner.

The resultant pressure  $R$  upon the base of the abutment is found by combining the weight  $W$  of the abutment with the thrust  $O-a$  of



the arch against the abutment. The footing under the base of the abutment should be so designed as properly to distribute the load over the foundation soil.

ART. 46. THE ELASTIC ARCH

**163. Analysis of Fixed Arch.**—Reinforced concrete arches are commonly constructed as solid curved beams firmly fixed to the abutments. In analyzing them, it is assumed that the abutments are immovable and the ends of the arch firmly held in their original positions. Let Fig. 88 represent the left half of an arch, fixed in position at the end  $G-H$ , and carrying loads which produce thrusts and bending moments throughout the arch ring.

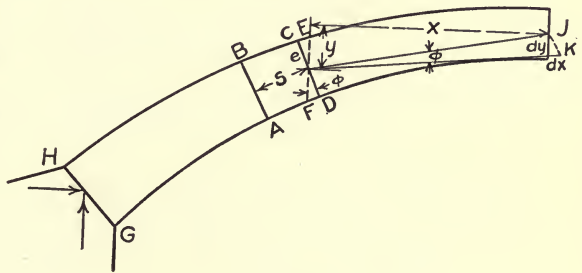

FIG. 88.

The arch may be considered as made up of a number of small divisions. Suppose  $ABCD$  to be one of these divisions, small enough so that its ends are practically parallel and its section area constant. The loads upon the arch bring a bending moment upon the division  $ABCD$ , which causes the end  $CD$  to take the position  $EF$ .

- Let
- $M$  = bending moment on the division;
  - $s$  = length of division,  $AD = BC$ ;
  - $e$  = distance from center of section to outside fiber;
  - $ds$  = elongation of fiber distant  $e$  from neutral axis;
  - $f_m$  = Unit stress upon fiber distant  $e$  from neutral axis;
  - $k$  = angle of distortion,  $COE$ ;
  - $E$  = modulus of elasticity of material;
  - $I$  = moment of inertia of section;
  - $x$  and  $y$  = horizontal and vertical coordinates of center of section,  $O$ , with reference to center of crown section,  $J$ .

The unit fiber elongation in the division  $ABCD$  is  $\frac{ds}{s} = \frac{ek}{s}$ .

$$\text{Unit stress, } f_m = \frac{Me}{I} \quad \text{also} \quad f_m = \frac{ds}{s} E = \frac{ek}{s} E.$$

Equating these and solving,

$$k = \frac{M_s}{EI} \dots \dots \dots (1)$$

If the crown of the arch be free to move, the deflection of  $ABCD$  into its new form  $ABEF$  will bring the middle point of the arch ring  $J$ , to the new position  $K$ . Let  $dx$  and  $dy$  be the horizontal and vertical coordinates of  $K$  with respect to  $J$ . Then from similar triangles,  $JK/OJ = dy/x = k$ , and

$$dy = xk = \frac{M_x s}{EI} \dots \dots \dots (2)$$

Similarly,

$$dx = yk = \frac{M_y s}{EI} \dots \dots \dots (3)$$

As the end section  $GH$  is fixed in position, the summation of all the angular distortions  $k$ , for the left half of the arch gives the distortion at the crown section. The summation similarly of those for the right half must give the same result with opposite sign, or indicating the left and right sides of the arch by the subscripts  $L$  and  $R$  respectively, and indicating summation by the sign  $\Sigma$ , we have

$$\Sigma k_L = -\Sigma k_R, \text{ also } \Sigma dy_L = \Sigma dy_R \text{ and } \Sigma dx_L = -\Sigma dx_R.$$

Substituting for these distortions, their values as found above, we have for a symmetrical arch:

$$\Sigma \frac{M_L s}{EI} = -\Sigma \frac{M_R s}{EI}, \dots \dots \dots (4)$$

$$\Sigma \frac{M_L x s}{EI} = \Sigma \frac{M_R x s}{EI}, \dots \dots \dots (5)$$

and

$$\Sigma \frac{M_L y s}{EI} = -\Sigma \frac{M_R y s}{EI} \dots \dots \dots (6)$$

If the length of the divisions of the arch ring be made directly proportional to the corresponding values of the moment of inertia,  $\frac{s}{I} = \text{constant}$ , the terms  $\frac{s}{EI}$  in Equations (4), (5), and (6) are constant and may be eliminated, and we have,

$$\Sigma M_L = -\Sigma M_R \dots \dots \dots (7)$$

$$\Sigma M_L x = \Sigma M_R x \dots \dots \dots (8)$$

$$\Sigma M_L y = -\Sigma M_R y \dots \dots \dots (9)$$

Fig. 89 represents a symmetrical arch divided into parts the lengths of which are directly proportioned to the moments of inertia of the cross-sections at their middle points.  $s/I = \text{constant}$ . Suppose the arch to be cut at the crown and the separate halves supported by introducing the stresses acting through the crown section as exterior forces. These may be resolved into a horizontal thrust, a vertical shear and a bending moment.

- $H_c$  = horizontal thrust at crown;
- $V_c$  = vertical shear at crown;
- $M_c$  = bending moment at crown.

$V_c$  is considered to be positive when acting in the direction indicated by the arrows. Moments are taken as positive when they

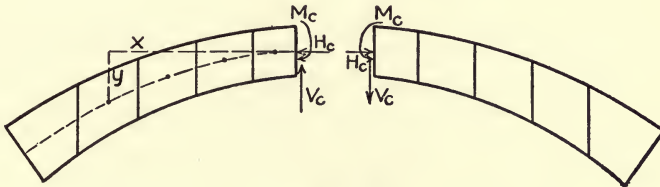

FIG. 89.

produce compression on the upper and tension on the lower side of the section.

- Let  $M_L$  = bending moment on mid-section of any division in left half of arch;
- $M_R$  = bending moment on mid-section of any division in right half of arch;
- $m_L$  = moment at middle of any division in left half, caused by external loads between that division and the crown section;
- $m_R$  = moment at mid-section of any division in right half, caused by external loads between that section and the crown section;
- $x$  and  $y$  = coordinates of middle point of any division with respect to middle of crown section.

The bending moment at any section of a beam is equal to the moment at any other section plus the moments of the intermediate loads about the center of the section. Therefore,

$$M_L = M_c + V_c x + H_c y - m_L, \quad \dots \dots \dots (10)$$

$$M_R = M_c - V_c x + H_c y - m_R. \quad \dots \dots \dots (11)$$



Substituting these values in Equations (7), (8) and (9), we have,

$$2nM_c + 2H_c \Sigma y - \Sigma m_L - \Sigma m_R = 0, \dots \dots (12)$$

$$2V_c \Sigma x^2 - \Sigma m_L x + \Sigma m_R x = 0, \dots \dots (13)$$

$$2M_c \Sigma y + 2H_c \Sigma y^2 - \Sigma m_L y - \Sigma m_R y = 0. \dots \dots (14)$$

Solving for the thrusts and moments at the crown

$$H_c = \frac{n \Sigma (m_L y + m_R y) - \Sigma (m_L + m_R) \Sigma y}{2n \Sigma y^2 - 2(\Sigma y)^2}, \dots \dots (15)$$

$$V_c = \frac{\Sigma m_L x - \Sigma m_R x}{2 \Sigma x^2}, \dots \dots (16)$$

$$M_c = \frac{\Sigma m_L + \Sigma m_R - 2H_c \Sigma y}{2n}. \dots \dots (17)$$

In analyzing an arch by this method, the arch is first divided into a number of parts in which  $s/I$  is a constant. The loads upon the divisions are then found and  $mL$  and  $mR$  computed for the several centers of division. The values of  $H_c$ ,  $V_c$  and  $M_c$  may then be found from Formulas (15), (16) and (17), after which the line of thrust may be drawn beginning with the known values of  $H_c$  and  $V_c$  at the crown. The moment  $M_c$  is due to the eccentricity of the thrust at the crown, and the point of application for  $H_c$  may be found by dividing  $M_c$  by  $H_c$ . This gives the vertical distance of  $H_c$  from the center of gravity of the crown section. For  $M_c$  positive,  $H_c$  is above, and for  $M_c$  negative,  $H_c$  is below the center of section.

The thrust at any section of the arch may be obtained from the thrust diagram as in the voussoir arch. The bending moment at any section is the moment of the thrust upon the section about the center of gravity of the section. The bending moment at any section may also be obtained by the use of Formula (10) or (11).

In analyzing an arch bridge subject to moving loads, it is necessary to assume different conditions of loading and find the thrust and moments resulting from each. For a small arch, it is usually sufficient to make the analysis for arch fully loaded and for moving load over one-half the arch. The maximum stresses will be more accurately determined by dividing the moving load into thirds, and determining the stresses with span fully loaded, one-third loaded, two-thirds loaded, center third loaded, and with two end thirds loaded. If complete analysis be made for the arch under dead load alone, for live load over one end third, and live load over the middle third, the results of these three analyses may be combined to give the five conditions of loading above mentioned.

**164. Effect of Changes of Temperature.**—A rise in temperature tends to lengthen and a fall in temperature to shorten the span. If the ends of the arch ring are rigidly held in position, the tendency to change in length is resisted by moments and horizontal thrusts at the supports, which produce moments and thrusts throughout the arch ring.

If the arch ring were not restrained, a rise in temperature of  $t$  degrees would cause an increase in length  $= CtL$ ;  $L$  being the length of span and  $C$  the coefficient of expansion of the material. The moments throughout the arch ring are therefore those which correspond to an actual change in length of span  $= CtL$ , or from Formula (3)

$$\Sigma dx = \Sigma \frac{Mys}{EI} = CtL.$$

From this, for a symmetrical arch ring

$$\Sigma \frac{M_L ys}{EI} = \Sigma \frac{M_R ys}{EI} = \frac{CtL}{2}, \dots \dots \dots (18)$$

and

$$\Sigma M_L = -\Sigma M_R. \dots \dots \dots (19)$$

As there are no exterior loads,  $m_L$ , and  $V_c$  are each equal to zero, and Formula (10) becomes  $M_L = M_c + H_c y$ . Substituting this in (18) and (19) and solving, we have

$$H_c = \frac{EI}{s} \cdot \frac{CtLn}{2n\Sigma y^2 - 2(\Sigma y)^2} \dots \dots \dots (20)$$

$$M_c = -\frac{H_c \Sigma y}{n} \dots \dots \dots (21)$$

The line of thrust consists of a single force  $H_c$ , and is applied on a horizontal line at a distance,  $e = \Sigma y/n$ , below the middle of the crown section. The bending moment at any section due to  $H_c$  is

$$M_L = H_c \left( y - \frac{\Sigma y}{n} \right) \dots \dots \dots (22)$$

The direct thrust upon any section of the arch ring is the component of  $H_c$  normal to the section.

For temperatures below the normal,  $H_c$  will be negative and may be found from Formula (20) by giving  $t$  the negative sign.

**165. Effect of Direct Thrust.**—Axial thrusts on the arch ring produce compressive stresses on the various sections and also tend to shorten the arch ring. As the span length does not change, this

tendency to become shorter causes stresses in the arch ring in the same manner as does lowering temperature. If  $f_c$  lb./in.<sup>2</sup> be the average unit compression due to axial thrust, the arch ring if unrestrained would be shortened an amount  $dx = f_c I / E$ , from which,

$$H_c = \frac{I}{s} \cdot \frac{f_c L n}{2n \Sigma y^2 - 2(\Sigma y)^2}$$

and

$$M_c = \frac{H_c \Sigma y}{n} \dots \dots \dots (23)$$

As the unit stress  $f_c$  is not uniform through the arch ring, a value obtained by finding the stresses at several points and averaging them may be used.

The stresses due to shortening of the arch ring are comparatively small and are often neglected in the analysis of ordinary arches; in some instances, however, they may be considerable.

**ART. 47. DESIGN OF REINFORCED CONCRETE ARCH**

**166. Selection of Dimensions.**—In designing an arch, it is necessary to first assume dimensions for the arch ring, and then investigate for the strength of the arch and the suitability of the assumed dimensions to the conditions of service. The methods of investigation usually employed are indicated in Art. 46. The investigation will show whether changes in form or thickness should be made in the arch ring. The shape of the arch should be such as to fit as closely as possible the lines of pressure, and the thickness should be such as to give allowable stresses under all conditions of loading.

*Example.*—As an illustration of the method of investigation, we will assume an arch of 60 feet clear span and 12 feet rise, to carry a live load of 100 pounds per square foot of road and a solid spandrel filling, 2 feet deep over the crown, weighing 100 pounds per cubic foot. For ordinary arches with solid spandrel filling, a three-centered intrados, with radii at the sides from three-fifths to three-fourths that at the crown, is apt to give better results than a segmental intrados. We will use an intrados composed of three arcs tangent to each other at the quarter points with radii of 52.5 feet and 31.25 feet respectively (see Fig. 91).

Weld's formula<sup>1</sup> for the crown thickness is  $t = \sqrt{L} + \frac{L}{10} + \frac{W}{200} + \frac{W'}{400}$

in which

<sup>1</sup> Engineering Record, Nov. 4, 1905.



- $t$  = the crown thickness in inches;  
 $L$  = clear span in feet;  
 $W$  = live load in pounds per square foot;  
 $W'$  = weight of fill at crown per square foot.

Applying this formula, we find a crown thickness of 16 inches. The thickness of the arch ring should increase from the crown to the springing line; the thickness at the quarter point may be made a little greater than that at the crown (about  $1\frac{1}{4}$  to  $1\frac{1}{3}$  times). We will assume a thickness at the quarter point of 21 inches, and at the springing line of 45 inches. The extrados will now consist of three arcs tangent to each other at the quarter points and giving the desired thicknesses. Fig. 117 shows the arch ring as assumed.

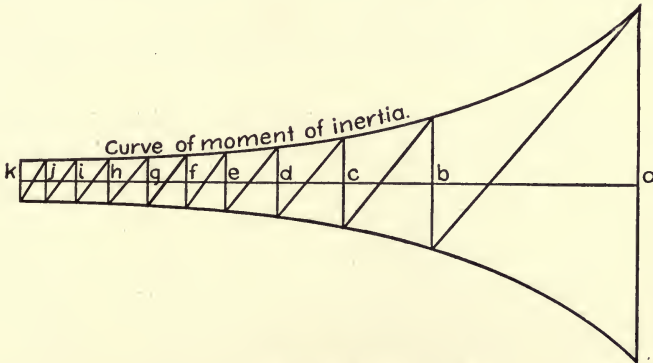

FIG. 90.

The reinforcement may be assumed at from .4 to .7 per cent of the area of the section at the crown, to be placed at both extrados and intrados. We will use  $\frac{7}{8}$ -inch round bars spaced 7 inches apart.

**167. Division of Arch Ring.**—Having chosen the form and dimensions of the arch ring, it is necessary to divide the ring so that the lengths of the divisions shall be directly proportional to the moments of inertia of their mid-sections,  $s/I = \text{constant}$ . This may be done by trial, assuming a division next the crown, determining the value of  $s/I$  for the assumed division, and finding the corresponding lengths of other sections toward the abutment. Then changing the first assumption as may seem necessary to make the division come out properly at the abutment.

More easily, the division may be made graphically as shown in Fig. 90. The line  $a-k$  is laid off equal in length to half the arch axis (34.52 feet). The moments of inertia are then computed at several points

along the arch axis, and their amounts laid off normally to the line  $a-k$ , and the curves of moment of inertia drawn through the points so located.

A trial diagonal is then drawn from  $A$  to intersection with the curve in the point  $B$ . A vertical from  $B$  is drawn to intersection with the upper curve, and a second diagonal parallel to  $A-B$ , cutting the lower curve in  $C$ . Continue successive diagonals and verticals until the end  $k$  is reached. If these do not come out accurately at the end  $k$  the inclination of the diagonals may be varied until the division of  $a-k$  is made into the correct number of parts. This divides  $a-k$  into lengths which are proportional to the average of the moments of inertia at the ends of the divisions.

The lengths of the divisions,  $a-b$ ,  $b-c$ , etc., are now transferred to the arch axis. The axis of the arch in Fig. 91 is thus laid off into ten divisions on each side of the crown section. The constant ratio  $s/I$  is found to be 5.1, all measurements being taken in feet.

The middle point of the arch axis in each division is now located, and the values of  $x$  and  $y$  are determined with reference to the middle of the crown section. These values and their squares are tabulated in Table XXI for use in the computations.

**168. Analysis.**—If vertical lines be drawn through the points of division of the arch axis, the weight of the portion of masonry and spandrel filling included between each pair of lines may be considered as the dead load resting upon the included division. The live load is similarly divided for the portion of the arch over which it is considered as acting. In Fig. 91 the live load is taken as extending over the left half of the arch, and the loads are as indicated. The values of  $m_L$  and  $m_R$  are now computed and placed in Table XXI, and include in each instance the moments of all loads between the division considered and the crown section about the center of division. The quantities  $m_Lx$ ,  $m_Rx$ ,  $m_Ly$ , and  $m_Ry$  may now be computed and placed in the table, and the summations of the various columns obtained. These substituted in Formulas (15), (16) and (17) give,

$$H_c = \frac{10(2375207 + 1989744) - (512291 + 425771)17.09}{2 \times 10 \times 80.85 - 2 \times 17.09 \times 17.09} = +26715.$$

$$V_c = \frac{10408051 - 8686133}{2 \times 1769.5} = +487 \text{ pounds,}$$

$$M_c = \frac{512291 + 425771 - 2 \times 26715 \times 17.09}{2 \times 10} = +1247 \text{ ft.-lb.}$$

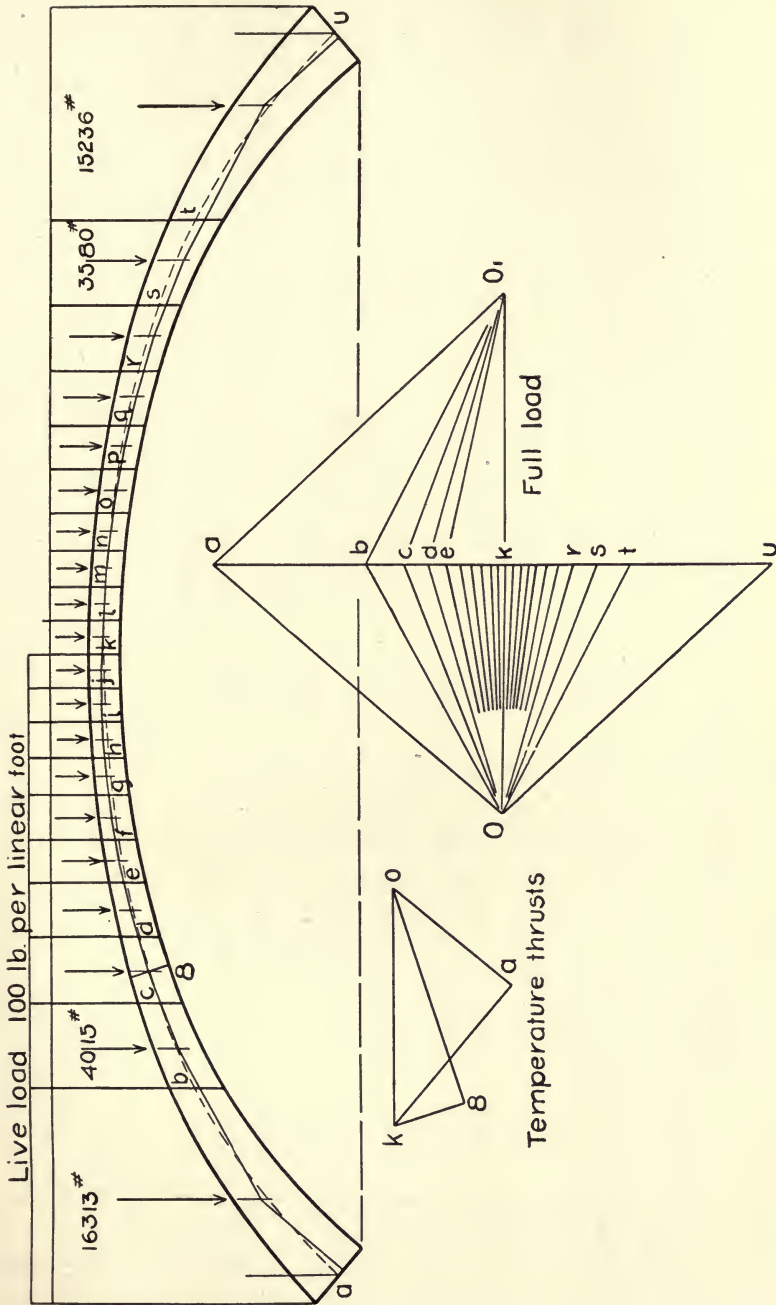

FIG. 91.



TABLE XXI.—ORDINATES AND MOMENTS FOR COMPUTATIONS

| Points.  | $x$    | $y$   | $x^2$  | $y^2$ | $m_R$   | $m_L$   | $m_{RX}$  | $m_{LX}$   | $m_{RY}$  | $m_{LY}$  |
|----------|--------|-------|--------|-------|---------|---------|-----------|------------|-----------|-----------|
| 1        | 0.84   | 0.01  | 0.7    | 0.00  | 00      | 00      | 00        | 00         | 00        | 00        |
| 2        | 2.56   | 0.06  | 6.5    | 0.00  | 1,230   | 1,519   | 3,149     | 3,889      | 74        | 91        |
| 3        | 4.32   | 0.16  | 18.7   | 0.03  | 3,812   | 4,703   | 16,468    | 20,317     | 610       | 752       |
| 4        | 6.16   | 0.34  | 38.0   | 0.11  | 7,990   | 9,841   | 49,218    | 60,620     | 2,717     | 3,346     |
| 5        | 8.14   | 0.58  | 66.4   | 0.34  | 14,237  | 17,502  | 115,889   | 142,467    | 8,257     | 10,151    |
| 6        | 10.33  | 0.95  | 106.9  | 0.90  | 23,389  | 28,670  | 241,609   | 296,151    | 22,210    | 27,236    |
| 7        | 12.85  | 1.45  | 165.4  | 2.12  | 37,012  | 45,195  | 475,594   | 580,756    | 53,667    | 65,534    |
| 8        | 15.88  | 2.25  | 252.5  | 5.06  | 58,125  | 70,608  | 923,025   | 1,120,255  | 130,781   | 158,868   |
| 9        | 19.75  | 3.58  | 390.4  | 12.85 | 93,992  | 113,278 | 1,856,342 | 2,237,240  | 336,491   | 405,535   |
| 10       | 29.91  | 7.71  | 724.0  | 59.44 | 185,984 | 220,972 | 5,004,839 | 5,946,356  | 1,433,937 | 1,703,694 |
| $\Sigma$ | 107.74 | 17.09 | 1769.5 | 80.85 | 425,771 | 512,291 | 8,686,133 | 10,408,051 | 1,988,744 | 2,375,207 |

Having obtained the thrusts and moment at the crown, we may now proceed to find the thrusts and moments at any other section desired. The thrusts are obtained graphically by drawing the line of pressure. The load line is first constructed, as shown by the vertical line  $a-u$ .  $V_c$  and  $H_c$  are laid off from the mid-point  $k$  of this line, thus locating the pole  $O$ . The force diagram is then completed by drawing connections from  $O$  to the extremities of the various loads.

The equilibrium polygon is now drawn, beginning with the crown thrust ( $O-K$ ), the point of application of which is at a point  $e = \frac{+1247}{+26715} = +0.05$  foot above the center of the crown section. The thrust upon each section is now shown in amount by the length of the line from  $O$  to the division in the load line, and its line of action by the corresponding line in the equilibrium polygon (or line of pressure).

The bending moment at any section may be found by multiplying the thrust upon the section by its perpendicular distance from the center of section, or it may be computed by the use of Formula (10) or (11). Usually the formula is employed and the measurement of the eccentricity used as a check.

**169. Computation of Stresses.**—*At the crown*, the stress due to direct thrust is

$$f_c = \frac{\text{thrust}}{\text{area}} = \frac{26715}{18 \times 12} = +124 \text{ lb./in.}^2;$$

for the moment,

$$f_c = \frac{M_c}{I} = \frac{1247 \times 12 \times 9}{6388} = 21 \text{ lb./in.}^2$$

This gives

$$124 + 21 = +145 \text{ lb./in.}^2 \text{ at the extrados}$$

and

$$124 - 21 = +103 \text{ lb./in.}^2 \text{ at the intrados.}$$

*At the left support*, by Formula (10),

$$M_L = 1247 + 26715 \times 11.7 + 487 \times 31.25 - 349930 = -20899 \text{ ft.-lb.}$$

and the measured thrust = 40300 pounds, giving an eccentricity of  $-20899/40300 = -.5$  foot. This may be checked by measurement. Then for thrust,

$$f_c = \frac{40300}{42 \times 12} = +80 \text{ lb./in.}^2$$

and for moment,

$$f_c = \frac{20899 \times 12 \times 21}{79098} = -67 \text{ lb./in.}^2,$$

giving at the extrados

$$f_c = 80 - 67 = +13 \text{ lb./in.}^2$$

and at the intrados

$$f_c = 80 + 67 = +147 \text{ lb./in.}^2$$

At the right support, by Formula (11),

$$M_R = 1247 + 26715 \times 11.7 - 487 \times 3125 - 303226 = -4632 \text{ ft.-lb.}$$

The measured thrust is 39,200, and the eccentricity

$$= -\frac{4632}{39200} = -.12 \text{ foot.}$$

For thrust,  $f_c = \frac{39200}{42 \times 12} = 78 \text{ lb./in.}^2$ , and for moment,  $f_c = -15 \text{ lb./in.}^2$

This gives at extrados  $f_c = 63 \text{ lb./in.}^2$ , and at intrados  $f_c = +93 \text{ lb./in.}^2$   
At point  $8_L$ ,

$$M_L = 1247 + 26715 \times 2.25 - 487 \times 15.88 - 70608 = -1520 \text{ ft./lb.}$$

Thrust = 27600 pounds

$$f_c = \frac{27600}{21 \times 12} = 110 \text{ lb./in.}^2$$

For moment,  $f_c = \frac{-1520 \times 12 \times 10.5}{10964} = 17 \text{ lb./in.}^2$ ;

this gives at extrados  $f_c = 93 \text{ lb./in.}^2$ , and at intrados  $f_c = 127 \text{ lb./in.}^2$

At point  $8_R$ , in the same manner, we have at extrados,  $f_c = 58 \text{ lb./in.}^2$  and at intrados  $f_c = 150 \text{ lb./in.}^2$

*Full Load.*—When the live load extends across the whole span of the arch, the loading is symmetrical and the values given in Table C for  $m_R$  become equal to those for  $m_L$ . We then have

$$V_c = 0.$$

$$H_c = \frac{2 \times 10 \times 2375207 - 2 \times 512291 \times 17.09}{2 \times 10 \times 80.85 - 2 \times 17.09 \times 17.09} = 29030 \text{ pounds}$$

$$M_c = \frac{2 \times 512291 - 2 \times 29030 \times 17.09}{2 \times 10} = +1662 \text{ ft.-lb.}$$

The force diagram is now drawn for one-half of the arch, and the equilibrium polygon may be drawn as in the case of partial loading. To avoid confusion it is not drawn in Fig. 91. The stresses in the crown section due to this loading are

$$f_c = \frac{29030}{18 \times 12} = 131 \text{ lb./in.}^2 \quad \text{and} \quad f_c = \frac{1662 \times 12 \times 9}{6388} = +28 \text{ lb./in.}^2$$



This gives at extrados, total  $f_c = 131 + 28 = +159$  lb./in.<sup>2</sup>, and at intrados, total  $f_c = 131 - 28 = 103$  lb./in.<sup>2</sup>

At section 8,  $M = 1662 + 29030 \times 2.25 - 70608 = -3629$  ft.-lb. The thrust is 30,350 pounds, and the resulting unit stresses at extrados  $f_c = 120 - 36 = 84$  lb./in.<sup>2</sup> and at intrados  $f_c = 156$  lb./in.<sup>2</sup>

At the support in the same manner, the thrust is 42,600 pounds, and the moment,  $M = 1662 + 29030 \times 11.7 - 349930 = -8617$  ft./lb. from which at extrados,  $f_c = 84 - 27 = 57$  lb./in.<sup>2</sup>, and at intrados  $f_c = 111$  lb./in.<sup>2</sup>

*Temperature Stresses.*—If we assume that a rise in temperature of 20° above the normal may take place, Formula (20) gives

$$H_c = \frac{288000000}{5.1} \times \frac{.000055 \times 20 \times 62.5 \times 10}{2 \times 10 \times 80.85 - 2 \times 17.09 \times 17.09} = +3770 \text{ pounds}$$

and (21),

$$M_c = \frac{-3770 \times 17.09}{10} = -6448 \text{ ft.-lb.} \quad e = \frac{6448}{3770} = -1.71 \text{ feet.}$$

The equilibrium polygon is a horizontal line 1.71 feet below the center of the crown section, and the bending moment at any section of the arch ring is equal to 3770 times the vertical distance from the center of section to the line of thrust. At point 8 the moment due to change of temperature is

$$3770 \times (2.25 - 1.71) = +2037 \text{ ft.-lb.}$$

and at point  $a$ ,

$$M = 3770 \times (11.7 - 1.71) = 37,696 \text{ ft.-lb.}$$

The stresses at the crown section are, at extrados

$$f_c = 17 - 112 = -95 \text{ lb./in.}^2,$$

and at intrados

$$f_c = 17 + 112 = +129 \text{ lb./in.}^2$$

The normal thrust on section at point 8 is the component of  $H_c$  normal to the section, given in diagram in Fig. 118, = 3345 pounds. At section  $a$ , thrust = 2510. These thrusts and moments give at 8, for extrados  $f_c = 14 + 24 = 38$  lb./in.<sup>2</sup>; for intrados,  $f_c = 14 - 24 = -10$  lb./in.<sup>2</sup> at support; extrados  $f_c = +127$  lb./in.<sup>2</sup>; intrados,  $f_c = -113$  lb./in.<sup>2</sup>

For a fall in temperature the stresses are equal and opposite to those for rising temperature.

*Arch Shortening.*—The effect of direct thrust in shortening the span of the arch, taking average unit compression as 100 lb./in.<sup>2</sup>

average of stresses at crown, point 8 and support under one-half live load by Formula (23),

$$H_c = \frac{1}{5.1} \cdot \frac{100 \times 144 \times 62.5 \times 10}{1033} = -1710 \text{ pounds.}$$

This is applied on the same line as the temperature thrust and the stresses are therefore equal to  $1710/3770 = .45$  of those for falling temperature.

Table XXII shows the computed stresses upon the sections at crown, at point 8 and at supports. Examination of this table shows that the unit compression is nowhere excessive. Tension of 34 lb./in.<sup>2</sup> occurs at the intrados in the crown section at low temperature. This is too small to cause cracking in the reinforced section. The tension of 150 lb./in.<sup>2</sup> at the extrados of the support section would possibly crack the concrete. The compression at the intrados under the same conditions would be 331 lb./in.<sup>2</sup>, and the reinforced section would be capable of bearing the load if the steel be assumed to carry all the tension. It might be desirable, however, to introduce additional reinforcement at this point to lessen the unit tension in the steel and prevent cracking, and these negative stresses might also be eliminated by slightly modifying the form of the arch, increasing the radius at the crown and decreasing those at the ends, although the form as shown agrees fairly well with the lines of thrust.

TABLE XXII.—STRESSES IN ARCH SECTIONS, LB/IN.<sup>2</sup>

| Character of Load.               | CROWN. |       | POINT 8 <sub>R</sub> . |       | POINT 8 <sub>L</sub> . |       | SUPPORT R. |       | SUPPORT L. |       |
|----------------------------------|--------|-------|------------------------|-------|------------------------|-------|------------|-------|------------|-------|
|                                  | Extr.  | Intr. | Extr.                  | Intr. | Extr.                  | Intr. | Extr.      | Intr. | Extr.      | Intr. |
| Dead and one-half live load..... | +145   | +103  | +58                    | +150  | +93                    | +127  | + 63       | + 93  | +13        | +147  |
| Dead and full live load.....     | +159   | +103  | +84                    | +156  | +84                    | +156  | + 57       | +111  | +57        | +111  |
| High temperature                 | - 95   | +129  | +38                    | - 10  | +38                    | - 10  | +127       | -113  | +127       | -113  |
| Low temperature.                 | +129   | - 95  | -10                    | + 38  | -10                    | + 38  | -113       | +127  | -113       | +127  |
| Arch shortening..                | + 58   | - 42  | - 5                    | + 17  | - 5                    | + 17  | - 50       | + 57  | - 50       | + 57  |
| Maximum stresses                 | +346   | +180  | +117                   | +211  | +126                   | +211  | +140       | +295  | +184       | +337  |
| Minimum stresses                 | +108   | - 34  | + 43                   | +157  | + 69                   | +134  | -106       | + 37  | -150       | + 55  |

## ART. 48. TYPES OF CONCRETE ARCHES

**170. Arrangement of Spandrels.**—In ordinary bridges of short span, solid arches with filled spandrels are commonly employed, as shown in the example of the last article. In such arches, spandrel walls are used to retain the filling above the arch ring. These are usually light reinforced walls and must be designed to resist the side pressure of the filling with its live load. When the depth of filling is considerable, a thin wall with counterforts is often employed.

For larger bridges, and where heavy filling would be required, open spandrels are often used. In these, the floor is usually carried by slabs and the loads are brought vertically upon the arch ring by cross walls. In such arches, the dead loads with their lines of action are definitely known, and the use of influence lines gives an accurate method of determining the effect of moving loads at any point of the road surface.

In a large open spandrel arch, the arch ring, instead of being solid, is frequently composed of two or more longitudinal ribs. The bridge floor is supported by beams and slabs, and the load transferred to the ribs by a series of columns. The determination of stresses is made in the same manner as for the solid arch, the whole section of the arch rib being used to carry loads brought by the columns, instead of determining loads and sections for a 1-foot slice of the arch ring. The loads must be brought upon the ribs axially, so as to produce no horizontal bending moment, and the width of the rib must be sufficient to enable it to act as a column between points of support. The width may increase from the crown to the support so as to maintain a proper relation between width and depth.

**171. Methods of Reinforcement.**—There are several methods of arranging the reinforcement in concrete arches. Numerous patented systems are more or less in use, while many designers place reinforcing bars in any way that seem to best meet their needs without following any particular system.

*The Monier system* was the earliest type invented, and consists in placing wire netting near the surfaces of the arch at both intrados and extrados. This system has been quite largely used in Europe.

*The Melan arch* has steel ribs, consisting of bent I-beams, or of built-up lattice girders, spaced 2 or 3 feet apart, extending from abutment to abutment, they are self-supporting, and may sometimes be used to carry the forms in placing the concrete for the arch ring.



Many Melan arches have been constructed in the United States, most of those built previous to 1900 being of this type.

In the *Thacher system*, steel bars are used in pairs, one immediately above the other, near the extrados and intrados, the bars being independent of each other. Several modifications of the Thacher system have been patented, in which the rods alternate in position or are connected in some way.

In other systems, attempts are made to use single tension bars, bent to pass from the extrados at certain points to the intrados at others as the occurrence of tensions may require.

When the stresses upon the concrete in an arch are kept within proper limits, the unit stresses upon the steel are very small, and more steel must be used than would be necessary to carry the tensions if reasonable unit stresses for the steel could be allowed. The steel is not therefore economically used in carrying stresses. It is rather intended to give added security against unforeseen contingencies, preventing cracks in the concrete, and guarding against distortions due to slight settlement of foundations or structural defects.

**172. Hinged Arches.**—Hinges are frequently used in arches for the purpose of making the stresses more nearly determinate, they give definite points through which the line of pressure must pass.

*Three-hinged Arches.*—Three hinges are usually employed and have the advantage of fixing the line of pressure so as to make it statically determinate. It is assumed that the hinge acts without friction and the line of pressure passes through the center of the hinges. Making this assumption, the horizontal and vertical components of the thrusts at the supports may be determined by means of moments about the hinge centers. In large arches the hinges have the advantage of eliminating the temperature stresses. Slight settlement of the foundations may occur in hinged arches without sensibly changing the stresses, while the accuracy of the computed stresses in a solid arch is dependent upon the rigidity of the supports. Hinges are usually expensive to construct, and the form of the arch, if economically designed, is not so graceful as that of a solid arch.

*Two-hinged Arches.*—Two hinges are sometimes used at the supports without the crown hinge. Two points upon the line of pressure are thus fixed and the vertical components of the end thrusts may be found by moments about the hinges. As the span of the arch remains unchanged upon the application of the loads, Formula (14) of Section 163 applies to this case, or

$$2M_c \Sigma y + 2H_c \Sigma y^2 - \Sigma m_L y - \Sigma m_R y = 0. \quad (14)$$

- Let  $R_L$  = vertical component of the thrust at left support;  
 $M_w$  = moment at crown of all loads between crown and left support;  
 $L/2$  = half span of the arch axis;  
 $h$  = rise of the arch axis.

Then using the same notation as for the solid arch,

$$M_c = R_L L/2 - H_c h - m_w. \dots \dots \dots (23)$$

Substituting this in (14), we have for arch with vertical loading,

$$H_c = \frac{\sum m_L y + \sum m_R y + 2m_w - R_L L}{2\sum y^2 - 2h}. \dots \dots \dots (24)$$

The thrusts and moments may now be determined in the same manner as for the solid arch.

**173. Unsymmetrical Arches.**—The formulas of Art. 46 apply only

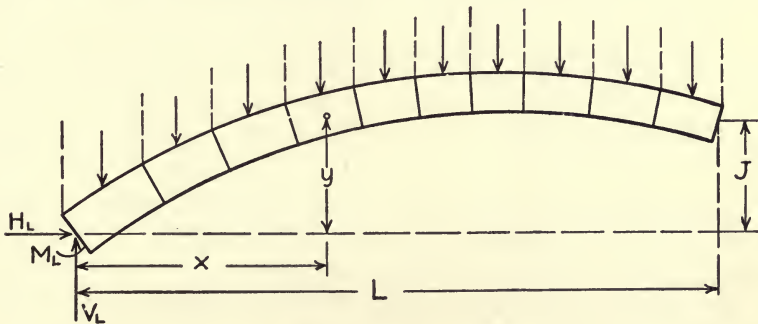

FIG. 92.—Unsymmetrical Arch.

to arch rings which are symmetrical with respect to the crown section. It is frequently necessary or desirable to construct arches which for topographical reasons are not alike upon the two sides of the crown. In these arches if  $s/I$  is made constant for the whole arch a division may not come at the crown section, the values of  $x$  and  $y$  will not be the same upon the two sides of the section nearest the crown, and the formulas produced as in Section 164 become quite complicated.

For this case, the origin of coordinates may be taken at the middle of the lower support, as in Fig. 92.

- Let  $M$  = bending moment at mid-point of any division;  
 $M_L$  = bending moment at left support;  
 $V_L$  = vertical component of thrust at left support;  
 $H_L$  = horizontal component of thrust at left support;

$x$  and  $y$  = coordinates of mid-points of divisions from center of left support;

$m$  = moment at any mid-point of division of all exterior loads between the division and the left support.

Then, using the method of Section 167, we have  $\Sigma M = 0$ ,  $\Sigma Mx = 0$ ,  $\Sigma My = 0$ , and

$$M = M_L + V_Lx - H_Ly - m. \quad \dots \quad (25)$$

From this by substitution we obtain

$$nM_L + V_L\Sigma x - H_L\Sigma y - \Sigma m = 0;$$

$$M_L\Sigma y + V_L\Sigma xy - H_L\Sigma y^2 - \Sigma my = 0;$$

$$M_L\Sigma x + V_L\Sigma x^2 - H_L\Sigma xy - \Sigma mx = 0.$$

Combining these and solving, we find

$$H_L = \frac{[n\Sigma x^2 - (\Sigma x)^2][\Sigma m\Sigma y - n\Sigma my] - [n\Sigma xy - \Sigma x\Sigma y][\Sigma m\Sigma y - n\Sigma mx]}{[n\Sigma x^2 - (\Sigma x)^2][n\Sigma y^2 - (\Sigma y)^2] - (n\Sigma xy - \Sigma x\Sigma y)^2}. \quad (26)$$

$$V_L = \frac{[\Sigma m\Sigma y - n\Sigma my] - H_L[n\Sigma y^2 - (\Sigma y)^2]}{\Sigma x\Sigma y - n\Sigma xy} \quad \dots \quad (27)$$

$$M_L = \frac{\Sigma m + H_L\Sigma y - V_L\Sigma x}{n} \quad \dots \quad (28)$$

Having found the values of  $H_L, V_L$  and  $M_L$ , the moment at any section may be calculated by Formula 25, and the line of pressure may be drawn, beginning at the left support.

The line of thrust due to change of temperature will be parallel to a line joining the ends of the arch axis.

If  $L$  = the horizontal span of the arch axis, and  $J$  = the height of its right end above its left end, using the notation of Section 168, we have

$$\Sigma M = 0, \Sigma Mys/EI = ctL/2,$$

$$M = M_L + V_Lx - H_Ly, V_L = H_LJ/L, M_L = \frac{H_L\Sigma y - V_L\Sigma x}{n}, \quad \dots \quad (29)$$

and

$$H_L = \frac{s}{EI} \cdot \frac{ctLn}{2 \frac{J}{L}(n\Sigma xy - \Sigma x\Sigma y) - 2[n\Sigma y^2 - (\Sigma y)^2]} \quad \dots \quad (30)$$

**174. Arches with Elastic Piers.**—In the ordinary theory of the elastic arch, the supports are supposed to be rigid and unyielding. This can never be strictly true, but it is practically correct where good foundations are obtained and a sufficient weight of abutment is used.



In the construction of a series of arches, light piers are sometimes employed to carry the vertical loads, the arches being depended upon to carry the horizontal reactions. In such systems, the tops of the piers are subject to lateral motion which may materially affect the stresses in the arch rings.

The bases of the piers must always be designed so that the resultant of the loads fall within their middle thirds, so that the bases will remain in contact with the foundations throughout. When this is the case, the piers become cantilevers held firmly at their bases and fixed between the arches at their upper ends.

When the structure is composed of nearly equal spans, and the thrust against the pier does not differ greatly on the two sides under dead load, the effect of the flexibility of the pier may be investigated for moving loads by a method of approximation. In Fig. 93,  $T_L$  and  $T_R$  are the thrusts of the spans upon the left and right respectively and  $R$  is their resultant acting upon the pier. The maximum load is supposed upon the left span and dead load only upon the right. The difference of the horizontal components of  $T_L$  and  $T_R$ ,  $H_L - H_R$ , is the horizontal component of  $R$ .

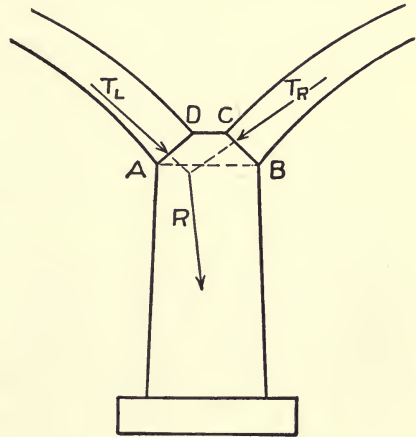

FIG. 93.

This is applied at the top of the pier, causing the pier to act as a cantilever fixed at the bottom. If we assume that the top of the pier is firmly held by the ends of the arch, so that no rotation takes place, the top of the pier will have only a horizontal motion. The effect of this motion is to lengthen the span of the arch upon the left of the pier and decrease that of the arch upon the right, which will decrease the value of  $H_L$  and increase that of  $H_R$ .

Let  $Q$  = the horizontal motion at top of pier;

$h$  = the height of pier;

$I_p$  = average moment of inertia of horizontal sections of pier.

The crown thrust for the span on the left then becomes,

$$H_c = \frac{n(\sum m_L y + \sum m_R y) - (\sum m_L + \sum m_R) \sum y}{2n \sum y^2 - 2(\sum y)^2} - \frac{nQEI/s}{2n \sum y^2 - 2(\sum y)^2} \quad (31)$$

and for the span upon the right,

$$H_c = \frac{n(\Sigma m_L y + \Sigma m_R y) - (\Sigma m_L + \Sigma m_R) \Sigma y}{2n \Sigma y^2 - 2(\Sigma y)^2} + \frac{nQEI/s}{2n \Sigma y^2 - 2(\Sigma y)^2} \cdot \quad (32)$$

$$Q = \frac{(H_L - H_R)h^3}{12EI_p}$$

The formulas for  $V_c$  and  $M_c$  are unchanged by the motion of the top of the pier, and are the same as for the arch with fixed ends.

If values of  $H_L$  and  $H_R$  be found by the formula for fixed supports, and the value of  $Q$  corresponding to their difference computed, the actual value of  $Q$  will be less than the computed value, and a trial value may be used in obtaining new values of  $H_L$  and  $H_R$ , until the values of the three quantities are in fair agreement.

The above is inaccurate in neglecting possible bending at the top of the pier. If the top of the pier in Fig. 93, be held against rotation, a bending moment will be produced in section  $A-B$  equal to  $M_p = (H_L - H_R)h/2$ . The actual bending moment in the section  $A-B$  is that produced by the eccentricity of the resultant of the thrusts of the arches against the pier, or  $M_p = Re$ . In order that no tendency to rotate exist,  $Re$  should not be less than  $(H_L - H_R)h/2$ . The error due to this cause may usually be made insignificant by careful design.

Methods of analyzing arches with elastic piers may be found in the works of Melan<sup>1</sup> and Hool.<sup>2</sup> In a paper by A. C. Janni in the Journal of the Western Society of Engineers, May, 1913, a graphical method of analysis is outlined, by the use of the ellipse of elasticity, which may be applied to a system of arches with elastic piers. These methods are complicated and cannot be discussed here; they all involve assumptions which make it necessary to exercise care in their application.

#### ART. 49. OTHER METHODS OF ANALYSIS

**175. Analysis by Influence Lines.**—In important structures, other conditions of loading than those mentioned in the preceding paragraphs may be desirable, and a more complete analysis may be obtained by determining the effect of individual loads at the various points of loading, which is accomplished by using influence lines to determine the effect of a unit load at each load point. In open spandrel arches, when the loads are brought upon the arch ring at defi-

<sup>1</sup> Plain and Reinforced Concrete Arches, by J. Melan, translated by D. B. Steinman, New York, 1915.

<sup>2</sup> Reinforced Concrete Construction, Vol. III, by George A. Hool, New York, 1915.

nite points, by vertical walls or columns, this method may be easily applied.

Fig. 94 represents an arch 80 feet long, 16 feet rise; depth at crown, 2 feet; at springing line, 2.8 feet. It is reinforced with 1.6 in.<sup>2</sup> of steel per foot of arch, placed 2.5 inches from both extrados and intrados. The loads are assumed to be applied through cross walls at points 10 feet apart.

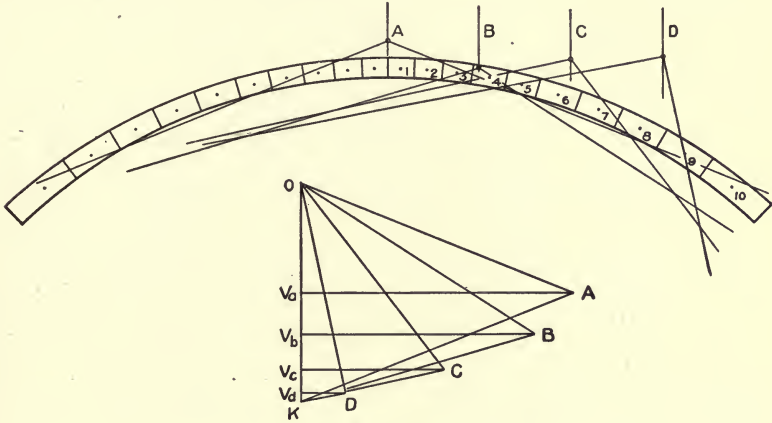

FIG. 94.

The arch ring is divided into ten parts on each side of the crown, so that the ratio  $s/I$  is constant;  $s$  being the length of division and  $I$  the moment of inertia at the middle of the division. Using the notation of Section 167, the values of  $x$  and  $y$  for centers of the various divisions are as given in Table XXIII.

TABLE XXIII

| Points.  | $x$    | $y$   | $x^2$  | $y^2$ |                                       |
|----------|--------|-------|--------|-------|---------------------------------------|
| 1        | 1.42   | 0.02  | 2.0    | 0.0   |                                       |
| 2        | 4.39   | 0.23  | 19.3   | 0.1   |                                       |
| 3        | 7.58   | 0.50  | 57.5   | 0.2   | $2n\Sigma y^2 - 2(\Sigma y)^2 = 3928$ |
| 4        | 11.01  | 1.06  | 115.8  | 1.1   |                                       |
| 5        | 14.70  | 1.89  | 216.1  | 3.6   |                                       |
| 6        | 18.67  | 3.09  | 348.6  | 12.1  | $2\Sigma x^2 = 8935.8$                |
| 7        | 22.94  | 4.73  | 502.5  | 22.4  |                                       |
| 8        | 27.50  | 6.94  | 756.3  | 48.2  | $2n = 20.$                            |
| 9        | 32.35  | 9.86  | 1046.5 | 97.2  |                                       |
| 10       | 37.46  | 13.72 | 1403.3 | 188.2 |                                       |
| $\Sigma$ | 178.02 | 42.04 | 4467.9 | 373.1 |                                       |



Values of  $m_L$ ,  $m_Lx$  and  $m_Ly$  are now computed for unit load at each load point and tabulated in Table XXIV.

TABLE XXIV

| Points. | LOAD AT A. |        |        | LOAD AT B. |        |        |
|---------|------------|--------|--------|------------|--------|--------|
|         | $m_L$      | $m_Lx$ | $m_Ly$ | $m_L$      | $m_Lx$ | $m_Ly$ |
| 1       | 1.42       | 2.0    | 0.0    |            |        |        |
| 2       | 4.39       | 19.3   | 1.0    |            |        |        |
| 3       | 7.58       | 57.5   | 3.8    |            |        |        |
| 4       | 11.01      | 115.8  | 11.1   | 1.01       | 11.1   | 1.0    |
| 5       | 14.70      | 216.1  | 27.8   | 4.70       | 69.1   | 8.9    |
| 6       | 18.67      | 348.6  | 57.7   | 8.67       | 161.9  | 26.8   |
| 7       | 22.94      | 526.2  | 108.5  | 12.94      | 296.8  | 61.2   |
| 8       | 27.50      | 756.3  | 190.9  | 17.50      | 481.2  | 121.5  |
| 9       | 32.35      | 1046.5 | 318.1  | 22.35      | 723.0  | 219.5  |
| 10      | 37.46      | 1403.3 | 514.0  | 27.46      | 1028.7 | 376.8  |
|         | 178.02     | 4467.9 | 1232.9 | 94.63      | 2770.7 | 813.7  |
|         | LOAD AT C. |        |        | LOAD AT D. |        |        |
| 7       | 2.94       | 67.4   | 13.9   |            |        |        |
| 8       | 7.50       | 206.2  | 52.1   |            |        |        |
| 9       | 12.35      | 399.5  | 120.9  | 2.35       | 76.0   | 22.3   |
| 10      | 17.46      | 644.1  | 239.6  | 7.46       | 269.5  | 102.4  |
|         | 40.25      | 1317.2 | 426.5  | 10.81      | 345.5  | 124.7  |

Substituting values from these tables in Formulas (12), (13), and (14), we have:

$$\text{Load at A. } \left\{ \begin{array}{l} H_e = \frac{10 \times 1232.9 - 178 \times 42.0}{3928} = +1.235 \\ V_e = \frac{4467.9}{8935.8} = 0.50 \\ M_e = \frac{178.0 - 2 \times 1.235 \times 42.0}{20} = +3.71 \end{array} \right.$$

$$\text{Load at B. } \left\{ \begin{array}{l} H_e = \frac{10 \times 813.7 - 94.6 \times 42.0}{3928} = -1.063 \\ V_e = \frac{2770.7}{8935.8} = 0.31 \\ M_e = \frac{94.6 - 2 \times 1.063 \times 42.0}{20} = +0.27 \end{array} \right.$$

$$\text{Load at } C. \left\{ \begin{array}{l} H_c = \frac{10 \times 426.5 - 40.2 \times 42.0}{3928} = 0.656 \\ V_c = \frac{1317.2}{8935.8} = 0.147 \\ M_c = \frac{40.2 - 2 \times 0.656 \times 42.0}{20} = -0.74 \end{array} \right.$$

$$\text{Load at } D. \left\{ \begin{array}{l} H_c = \frac{10 \times 124.7 - 10.8 \times 42.0}{3928} = 0.20 \\ V_c = \frac{345.5}{8935.8} = 0.04 \\ M_c = \frac{10.8 - 2 \times 0.20 \times 42.0}{20} = -0.30 \end{array} \right.$$

The thrusts and moments at any given section of the arch ring, due to each load, may now be found graphically (see Fig. 94). For this purpose, draw the force polygon, laying off  $O-K=1.0$ , the unit load. From  $K$ , the value of  $V_c$  is measured vertically,  $K-v=V_c$ , for each load, and  $H_c$  horizontally,  $v-A$ ,  $v-B$ , etc. The distance  $M_c/H_c$ , measured vertically from the middle point of the crown section, gives the point of application of the crown thrust,  $k-A$ ,  $k-B$ , etc. The equilibrium polygon in each case consists of two lines intersecting on the line of action of the loads and parallel to the corresponding lines in the force polygon.

The thrusts upon any section of the arch ring due to each unit load may now be taken from the force polygon, while the moment is found by multiplying the value of  $H_c$  for the given load by the vertical distance from the center of section to the equilibrium polygon.

Moments and thrusts at any section due to dead or live load at each load point may now be found by multiplying the values found for unit load by the amount of the load. If these be tabulated and combined, the maximum and minimum stresses may be obtained.

**176. Analysis Using Arbitrary Divisions.**—The method of analysis given in Art. 46 requires that the arch ring be so divided as to make  $s/I$  constant for all divisions. This simplifies the formulas used in obtaining values for  $H_c$ ,  $V_c$ , and  $M_c$ , but makes the lengths of divisions vary greatly where the thickness of the arch ring increases from crown to springing line, and frequently gives very long divisions near the ends of the arch, which may sometimes introduce considerable error into the results.

A method of analysis based upon the principle of work in deflec-

tion is sometimes employed. This is demonstrated by Professor Hudson<sup>1</sup> and is applied to the analysis of the stresses in a conduit by Professor French<sup>2</sup> under the name of the method for indeterminate structures. Practically the same formulas may be produced by the method of Art. 46 by leaving the term  $s/I$  as a variable in the formulas.

If the constant  $E$  be eliminated from Formulas (4), (5), and (6) of Section 163, we have

$$\Sigma M_L \frac{s}{I} = -\Sigma M_R \frac{s}{I}, \Sigma M_L x \frac{s}{I} = \Sigma M_R x \frac{s}{I} \text{ and } \Sigma M_L y \frac{s}{I} = -\Sigma M_R \frac{s}{I}.$$

Combining these with Equations (10) and (11) of the same section, and solving we find

$$H_c = \frac{\Sigma(m_L + m_R)y \frac{s}{I} \cdot \Sigma \frac{s}{I} - \Sigma(m_L + m_R)\frac{s}{I} \cdot \Sigma y \frac{s}{I}}{2\Sigma y^2 \frac{s}{I} \Sigma \frac{s}{I} - 2\left(\Sigma y \frac{s}{I}\right)^2} \dots (33)$$

$$V_c = \frac{\Sigma(m_L - m_R)x \frac{s}{I}}{2\Sigma x^2 \frac{s}{I}} \dots \dots \dots (34)$$

$$M_c = \frac{\Sigma(m_L + m_R)\frac{s}{I} - 2H_c \Sigma y \frac{s}{I}}{2\Sigma \frac{s}{I}} \dots \dots \dots (35)$$

In the same manner for a rise in temperature, we have

$$H_c = \frac{E_c \Delta L \Sigma \frac{s}{I}}{2\Sigma \left(y \frac{s}{I}\right)^2 + \Sigma y^2 \frac{s}{I} \cdot \Sigma \frac{s}{I}}$$

and

$$M_c = \frac{H_c \Sigma y \frac{s}{I}}{\Sigma \frac{s}{I}}$$

As an illustration of the use of this method of analysis we will

<sup>1</sup> Deflections and Statically Indeterminate Stresses, New York, 1911.

<sup>2</sup> American Sewage Practice, by Metcalf and Eddy, Vol. I, New York, 1914.



compute the values of  $H_c$ ,  $V_c$  and  $M_c$  for the arch ring given in the example of Art. 47 with the loading employed in Section 168. Fig. 95 shows the arch with divisions of equal length and the loads upon

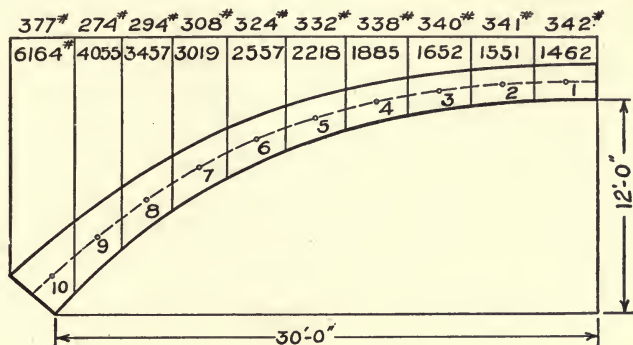

FIG. 95.

each division. Table XXV gives the coordinates of the centers of divisions, the value of  $s/I$  for the mid-section of each division, and

TABLE XXV.—COORDINATES AND  $s/I$  FOR CENTERS OF DIVISION

| Points.  | $x$   | $y$   | $s/I$ | $xs/I$ | $ys/I$ | $x^2s/I$ | $y^2s/I$ |
|----------|-------|-------|-------|--------|--------|----------|----------|
| 1        | 1.71  | 0.03  | 9.17  | 16.26  | 0.28   | 27.6     | 0.00     |
| 2        | 5.12  | 0.22  | 7.90  | 40.45  | 1.76   | 207.0    | 0.39     |
| 3        | 8.53  | 0.62  | 6.62  | 56.47  | 4.10   | 481.9    | 2.52     |
| 4        | 11.92 | 1.02  | 5.63  | 67.10  | 5.64   | 800.0    | 5.85     |
| 5        | 15.27 | 2.02  | 4.83  | 73.75  | 9.76   | 1126.4   | 19.70    |
| 6        | 18.55 | 3.09  | 3.62  | 67.15  | 11.19  | 1245.6   | 34.57    |
| 7        | 21.27 | 4.47  | 2.62  | 57.98  | 11.71  | 1234.8   | 52.40    |
| 8        | 24.72 | 6.15  | 1.86  | 45.98  | 11.44  | 1136.6   | 70.35    |
| 9        | 27.56 | 8.12  | 1.30  | 35.83  | 10.56  | 987.7    | 85.71    |
| 10       | 30.19 | 10.35 | 0.83  | 25.06  | 8.59   | 756.5    | 88.91    |
| $\Sigma$ |       |       | 44.72 |        | 75.03  | 8004.1   | 360.40   |

combinations of these quantities required in the computations. Table XXVI gives the computations of the moments at centers of divisions, and of the terms in the formulas which include these moments. These computations might be somewhat shortened by expressing the loads in Kips of 1000 pounds and the moments as foot-kips.

TABLE XXVI.—MOMENT COMPUTATIONS

| Points.  | TOTAL LOADS. |       | Lever Arms. | $m_R$   | $m_L$   | $(m_L - m_R)x \frac{s}{l}$ | $(m_L + m_R)\frac{s}{l}$ | $(m_L + m_R)y \frac{s}{l}$ |
|----------|--------------|-------|-------------|---------|---------|----------------------------|--------------------------|----------------------------|
|          | Dead.        | Live. |             |         |         |                            |                          |                            |
| 1        | 0            | 0     | 0           | 0       | 0       | 0                          | 0                        | 0                          |
| 2        | 1,462        | 342   | 3.41        | 4,985   | 6,151   | 47,223                     | 87,974                   | 19,354                     |
| 3        | 3,013        | 683   | 3.41        | 15,256  | 17,751  | 140,967                    | 218,506                  | 135,473                    |
| 4        | 4,665        | 1,023 | 3.39        | 31,069  | 36,032  | 333,017                    | 377,778                  | 385,333                    |
| 5        | 6,550        | 1,361 | 3.35        | 52,012  | 62,534  | 777,523                    | 553,256                  | 1,117,577                  |
| 6        | 8,768        | 1,693 | 3.28        | 80,791  | 96,866  | 1,078,632                  | 643,118                  | 1,987,234                  |
| 7        | 11,325       | 2,017 | 3.16        | 116,578 | 139,027 | 1,302,042                  | 669,785                  | 2,993,939                  |
| 8        | 14,344       | 2,325 | 3.01        | 159,753 | 189,200 | 1,354,562                  | 649,032                  | 3,993,546                  |
| 9        | 17,801       | 2,619 | 2.84        | 210,308 | 247,193 | 1,320,483                  | 549,751                  | 4,829,378                  |
| 10       | 21,856       | 2,893 | 2.63        | 267,789 | 312,283 | 1,116,799                  | 481,459                  | 4,983,100                  |
| $\Sigma$ |              |       |             |         |         | 7,471,248                  | 4,274,659                | 20,444,934                 |

Substituting values from the tables in Formulas (33), (34), and (35) we have,

$$H_c = \frac{20444934 \times 44.7 - 4274659 \times 75}{2 \times 360 \times 44.7 - 2 \times (77)^2} = +28340 \text{ pounds.}$$

$$V_c = \frac{7471248}{2 \times 8004} = +467 \text{ pounds.}$$

$$M_c = \frac{4274659 - 28340 \times 75}{2 \times 44.7} = +153 \text{ ft.-lb.}$$

These results are preferable to those obtained in Section 168 on account of the better division of the arch axis and the inclusion of a larger portion of the load in the moments. The labor required in the use of this method is not materially greater than that involved in the use of the ordinary method as given in Section 168.

## CHAPTER XI

### CULVERTS AND CONDUITS

#### ART. 50. CULVERTS

**177. Types of Culverts.**—The term culvert is usually applied to structures intended to provide small waterways through earth embankments. Such structures are usually constructed according to certain standard plans, depending upon the size of opening required. For the smaller openings, pipe culverts of vitrified clay, plain or reinforced concrete, cast iron or corrugated iron, are frequently used.

For openings larger than 24 or 30 inches in diameter, box culverts or arch culverts of stone or brick masonry or of concrete, either plain or reinforced are commonly employed. Concrete for this purpose has recently been gradually replacing the older types of construction, on account of its ease of application in most localities, and its low cost as compared with other types of equal strength and durability.

Wooden culverts have been largely used in the past upon highway work, but are now rapidly giving way to more permanent structures, for, while cheaper in first cost than the other types, they are very uneconomical on account of their rapid deterioration and high cost of maintenance.

All culverts require walls of masonry or concrete at the ends to prevent the possible penetration of water around the culvert, and to sustain the bank of earth and hold it from falling into and clogging the waterway. For small culverts, such walls are usually parallel to the roadway; they should be long enough to permit the earth to stand at a slope of about  $1\frac{1}{2}$  to 1 without reaching the waterway of the culvert and sufficiently high to sustain the earth fill above the culvert.

**178. Area of Waterway Required.**—The waterway provided for a culvert must, for safety, be sufficiently large to pass the maximum flow of water that is likely to occur, while for economy it should be as small as possible. There are at long intervals, in most localities, records of storms of extraordinary character, to provide for which would need large increase of capacity in the culverts and add greatly



to their cost, and while these unusual storms can hardly be taken into account in the design of the structures, effort should be made to provide for any flow of water that may reasonably be anticipated. The maximum flow of a stream depends upon a number of local conditions, most of which are very difficult of accurate determination. Among these are the maximum rate of rainfall, the area drained by the stream, the shape and character of the surface drained, and the nature and slope of the culvert channel.

The maximum rate of rainfall varies widely in different localities, the heaviest occurring over very limited areas and short periods of time, and are therefore important only for small culverts. For larger areas, the maximum rainfall of sufficient duration to permit water from all parts of the tributary area to reach the culvert gives maximum results.

The amount of water reaching the culvert depends upon the permeability of the soil, its degree of saturation, and the amount of vegetation. The rapidity with which water reaches the culvert from the far portion of the watershed depends upon the slope and smoothness of the surface and whether it is covered with vegetation. The shape of the area to be drained is important in that it determines the distance the water must travel in reaching the culvert.

The quantity of water which will pass through a culvert in a given time depends upon the smoothness of its interior surface, the disturbance of flow at entrance to the culvert, and the freedom with which the water flows away after passing the culvert. If the culvert is so constructed that water may stand against its upper end, causing it to discharge under pressure, its capacity will be considerably increased.

The determination of the area of waterway required in any instance is a matter of judgment, and there is no way in which it may be accurately computed. A number of formulas have been proposed for the purpose of aiding in estimating the probable quantity of water from a given area or the size of opening required for a given area. The formula of Professor Talbot has been used to considerable extent in the Middle West with good results. This formula is: Area of waterway in feet =  $C\sqrt[3]{(\text{drainage area in acres})^3}$ , in which  $C$  is a coefficient depending upon local conditions. For rolling agricultural country subject to floods at time of melting snow, and with length of valley three or four times its width,  $C = \frac{1}{3}$ . When the valley is longer, decrease  $C$ . If not affected by snow and with greater lengths,  $C$  may be taken at  $\frac{1}{5}$ ,  $\frac{1}{8}$ , or even less. For steep side slopes,  $C$  should be increased. Where the ground is steep and rocky,  $C$

may vary from  $\frac{2}{3}$  to 1. Table XXVII gives roughly the sizes of openings required for different areas, computed from the formula of Professor Talbot.

TABLE XXVII.—AREA IN SQUARE FEET OF WATERWAY REQUIRED

| Area Drained,<br>Acres. | Steep Slopes,<br>Sq. Ft. | Rolling Agricultural<br>Country,<br>Sq. Ft. | Level Country,<br>Sq. Ft. |
|-------------------------|--------------------------|---|---------------------------|
| 10                      | 6                        | 2   | 1                         |
| 25                      | 11                       | 4   | 2                         |
| 50                      | 19                       | 7   | 4                         |
| 75                      | 25                       | 9   | 5                         |
| 100                     | 32                       | 11  | 6                         |
| 200                     | 54                       | 18  | 10                        |
| 300                     | 72                       | 24  | 15                        |
| 500                     | 106                      | 35  | 21                        |
| 1000                    | 180                      | 60  | 35                        |

For most cases in practice the size of waterway may be determined from the knowledge which usually exists in the vicinity regarding the character of a stream, from the sizes of other openings upon the same stream, or from comparison with other streams of like character and extent in the same locality. Where data of this kind do not exist, careful examination of water marks on rocks, the presence of drift, etc., may be made to determine the height to which water has previously risen. The shape of the valley and the slope of the surface is of more importance than the area of country drained. The use of a formula like Talbot's assists the arrangement of the factors which enter into the determination, and is intended only as an aid to judgment in selecting the size of opening required.

**179. Pipe Culverts.**—Vitrified clay pipes make satisfactory as well as comparatively cheap culverts when small openings are required, and for openings from 12 to 24 inches in diameter, they may often be used economically. It is not usually desirable to build a culvert less than 12 inches in diameter. For those larger than 24 inches concrete will usually be found more suitable, although vitrified pipes 30 and 36 inches in diameter are sometimes used.

The best quality of double-strength, salt-glazed sewer pipe should be used for culverts. These pipes are made in lengths of 24 and 30 inches and diameter from 12 to 36 inches, with socket joints. They should be sound and well burned, giving a clear ring when lightly struck with a hammer.

The joints should be filled with Portland cement mortar a requirement particularly necessary where the pipe is likely to flow full, or under pressure, as it will prevent the water being forced out and the earth being washed from around the pipe.

Vitrified pipes cannot safely be used where they are directly exposed to the shocks of traffic, and many failures of such culverts have been due to this cause. In highway work they should be protected by at least 2 feet of filling, the roadway being graded so that a vehicle may pass smoothly and without shock over the culvert. In railway work a fill of about 5 feet over the culvert is usually necessary. The use of vitrified pipe for railway culverts is desirable only under favorable conditions, when danger from shocks of traffic can be avoided, and good foundations make breakage from settlement improbable.

The cost of vitrified pipe varies widely with the conditions of trade, and with the expense for freight and haulage to the site of the work. The cost of laying the pipe depends upon local conditions and the way the work is handled. Table XXVIII gives areas, weights, and rough averages of costs in a number of localities in the Middle West before the War.

TABLE XXVIII.—APPROXIMATE DIMENSIONS, WEIGHTS AND COSTS OF VITRIFIED PIPE CULVERTS

| Inside Diameter, Inches.....         | 12     | 15     | 18     | 24     |
|--------------------------------------|--------|--------|--------|--------|
| Area opening, square feet.....       | 0.78   | 1.26   | 1.76   | 3.14   |
| Weight of pipe, pounds per foot..... | 52     | 70     | 100    | 175    |
| Cost of pipe, per foot.....          | \$0.40 | \$0.50 | \$0.75 | \$1.20 |
| Cost of laying, per foot.....        | 0.40   | 0.60   | 0.75   | 1.25   |

The ends of pipe culverts should always be protected by a masonry or concrete wall. Fig. 96 shows a vitrified pipe culvert with end wall as used in highway work. These walls should extend at least 2 feet below the bottom of the culvert to prevent water passing under the culvert and undermining it, and should also reach above the surface of the roadway, thus serving as a protection both to the culvert and to the road. When the culvert is under an embankment, the wall should rise high enough to catch the slope of the embankment and form a curb to retain the earth.

Table XXIX gives dimensions that may be used for end walls for highway culverts under ordinary conditions.



*Culverts of cast-iron pipe* have been used to considerable extent in railway work for sizes from 1 to 4 feet in diameter. The present tendency, however, is to use concrete for the larger openings, on

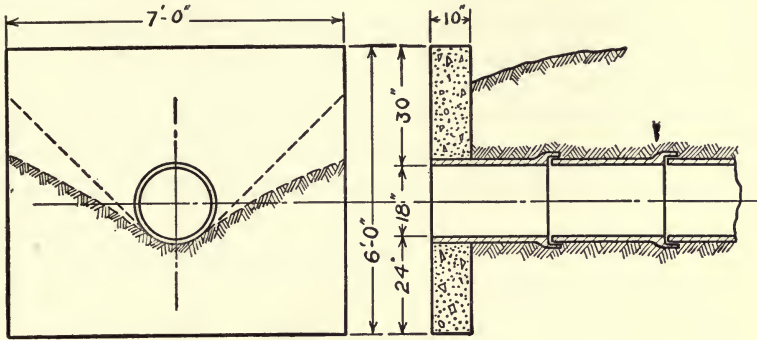

FIG. 96.—Vitrified Pipe Culvert.

account of its relative cheapness and the occasional cracking of the large iron pipes. Ordinary water pipe is sometimes used, but heavier pipe made for the purpose is more commonly employed.

TABLE XXIX.—CONCRETE END WALLS FOR PIPE CULVERT

| Diameter of Pipe, Inches.....           | 12  | 15  | 18  | 24  |
|---|-----|-----|-----|-----|
| Thickness of walls, inches.....         | 10  | 10  | 10  | 10  |
| Height of walls, feet, inches.....      | 5-6 | 5-9 | 6-0 | 6-6 |
| Length of walls, feet, inches.....      | 5-0 | 6-0 | 7-0 | 9-0 |
| Concrete in two walls, cubic yards..... | 1.7 | 2.1 | 2.5 | 3.4 |

For highway work, cast-iron pipe has the advantage of resisting shocks better than vitrified pipe, and may be used for small openings where the service is severe. It is not extensively used on account of its cost. Special culvert pipes in lengths of 3 or 4 feet are now available, which are made lighter than ordinary water pipe, some of them being made with a thinner shell reinforced by ribs. They are also made in longitudinal sections to be bolted together.

*Corrugated metal culvert pipe* is made lighter than cast iron, and does not ordinarily differ greatly in price from clay pipe. It is rather easy to handle and is less likely to break under shocks than vitrified pipe. It should, however, be covered by a thickness of at least 1 foot of road material.

The life of a culvert of this kind depends upon the ability of the metal to resist rust. Wrought iron is much better than steel in this respect, but must be selected with special reference to its resisting qualities. Pipes made of nearly pure iron have given good results, although numerous failures have resulted from the use of improper material.

*Concrete Pipe Culverts.*—Reinforced concrete culvert pipes are sometimes made from 18 to 48 inches in diameter, and in lengths from 4 to 8 feet. They usually have a hoop reinforcement, as shown in Fig. 97, passing near the interior surface at top and bottom and

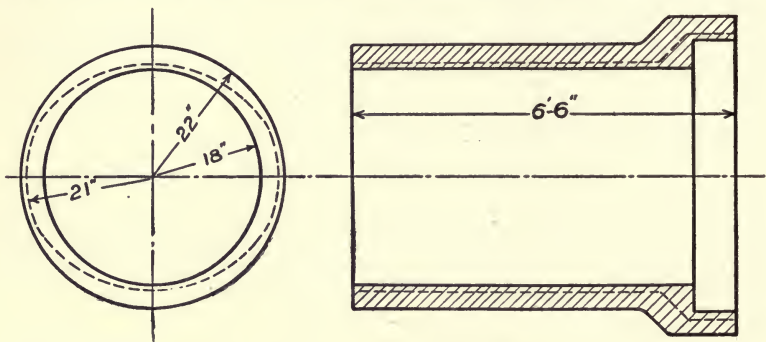

FIG. 97.—Concrete Culvert Pipe.

near the exterior surface at the sides, the reinforcement being bent to circular form and the pipe made in oval form with the larger diameter vertical. Concrete pipe is also sometimes made with a double reinforcement, one line near each surface. Table XXX gives dimensions recommended by the Iowa State Highway Commission for circular pipe with double reinforcement.

TABLE XXX.—CONCRETE CULVERT PIPE

| Diameter,<br>Inches. | Thickness of Shell,<br>Inches. | Steel Area for<br>Each Line,<br>Per Foot of Pipe. |
|----------------------|--------------------------------|---|
| 15                   | 2.25                           | .058 in. <sup>2</sup>                             |
| 18                   | 2.50                           | .077 in. <sup>2</sup>                             |
| 24                   | 3.00                           | .102 in. <sup>2</sup>                             |
| 30                   | 3.50                           | .151 in. <sup>2</sup>                             |
| 36                   | 4.00                           | .170 in. <sup>2</sup>                             |
| 42                   | 4.50                           | .225 in. <sup>2</sup>                             |

The load to be carried by a culvert under an embankment may usually be taken as equal to the weight of embankment immediately

above the culvert, and the live load carried by the roadway considered as distributed through the fill. For pipes in trenches the weight of filling is partly borne by the sides of the trenches. A study of pressures on pipes in trenches has been made by Professor Marston at the Iowa State College, and the very interesting results published in a bulletin of the Engineering Experiment Station of the College.

A uniform horizontal earth pressure over the whole width of a pipe produces positive bending moments at the top and bottom sections and negative moments at the ends of the horizontal diameter which are each equal to  $M = Wd/16$ , where  $W$  is the total load and  $d$  the diameter of the pipe. The pipe must be uniformly supported over its whole width in this case. If it is supported only at the middle, as when laid in a flat trench, the moments at top and bottom will be about doubled. In laying pipe the bottom of the trench should be rounded to fit it, being cut a little deeper under the middle, so that the bottom is free, not quite touching the soil, and letting the pipe rest upon the soil at the sides. Depressions should also be dug for the sockets to prevent the pipes being supported at the sockets and thus subjected to longitudinal bending.

Pipe should be laid from the down stream end with the sockets upstream. It is also desirable to give a slight crown to the grade of the culvert to provide for possible settlement.

**180. Box Culverts.**—Rectangular culverts are commonly used for sizes too large for pipes. These may be open boxes consisting of a slab top resting upon sidewalls, or closed boxes, in which a bottom slab connects the bases of the side walls and distributes the load over the foundation soil.

*Stone box culverts* have been extensively used in the past, but are now being superseded by reinforced concrete; but where suitable stone is available, they may often be found satisfactory and economical.

The side and end walls should be built of stone at least 6 inches thick, laid in cement mortar, and with frequent headers extending through the wall. The walls should extend downward sufficiently to obtain good foundations and to be safe from frost. The floor of the culvert between the side walls should be paved with stone, unless it is of material which will resist erosion.

The width of opening for stone box culverts is limited by the dimensions of the cover stones available and is never more than 4 or 5 feet. The cover stones should have a thickness at least one-quarter of the width of opening, and should have a bearing of about 1 foot upon each wall.



TABLE XXXI.—CONCRETE BOX CULVERTS

|   |               |               |               |               |               |               |               |               |               |
|---|---------------|---------------|---------------|---------------|---------------|---------------|---------------|---------------|---------------|
| Size of opening:                          |               |               |               |               |               |               |               |               |               |
| Span, feet.....                           | 5             | 5             | 6             | 6             | 8             | 8             | 8             | 8             | 8             |
| Height, feet.....                         | 3             | 4             | 3             | 4             | 5             | 5             | 5             | 5             | 6             |
| Top slab:                                 |               |               |               |               |               |               |               |               |               |
| Thickness of concrete, inches.....        | 7½            | 7½            | 8             | 8             | 8             | 8             | 8             | 10            | 10            |
| Reinforcement:                            |               |               |               |               |               |               |               |               |               |
| Diameter of round steel rods, inches..... | $\frac{3}{4}$ | $\frac{3}{4}$ | $\frac{3}{4}$ | $\frac{3}{4}$ | $\frac{3}{4}$ | $\frac{3}{4}$ | $\frac{3}{4}$ | $\frac{3}{4}$ | $\frac{3}{4}$ |
| Spacing of rods, c. to c., inches.....    | 7½            | 7½            | 7             | 7             | 7             | 7             | 7             | 5½            | 5½            |
| Length of rods, feet, inches.....         | 6-6           | 6-6           | 7-8           | 7-8           | 7-8           | 7-8           | 7-8           | 9-8           | 9-8           |
| Reinforcement lengthwise:                 |               |               |               |               |               |               |               |               |               |
| Diameter of steel rods, inches.....       | $\frac{1}{2}$ | $\frac{1}{2}$ | $\frac{1}{2}$ | $\frac{1}{2}$ | $\frac{1}{2}$ | $\frac{1}{2}$ | $\frac{1}{2}$ | $\frac{1}{2}$ | $\frac{1}{2}$ |
| Spacing of rods, c. to c., inches.....    | 12            | 12            | 12            | 12            | 12            | 12            | 12            | 12            | 12            |
| Quantities per foot of length:            |               |               |               |               |               |               |               |               |               |
| Concrete, cubic yards.....                | 0.16          | 0.16          | 0.20          | 0.20          | 0.20          | 0.20          | 0.20          | 0.31          | 0.31          |
| Steel, pounds.....                        | 13.5          | 13.5          | 17.1          | 17.1          | 17.1          | 17.1          | 17.1          | 26.7          | 26.7          |
| Abutments:                                |               |               |               |               |               |               |               |               |               |
| Thickness at top, inches.....             | 10            | 10            | 12            | 12            | 12            | 12            | 12            | 12            | 12            |
| Thickness at bottom, inches.....          | 24            | 24            | 24            | 24            | 30            | 30            | 30            | 30            | 36            |
| Height, feet and inches.....              | 4-6           | 5-6           | 4-6           | 5-6           | 6-6           | 6-6           | 6-6           | 6-6           | 7-6           |
| Concrete per foot, cubic yards.....       | 0.47          | 0.58          | 0.50          | 0.61          | 0.84          | 0.84          | 0.84          | 0.84          | 1.10          |

*Concrete box culverts* are sometimes constructed with a reinforced slab top resting upon side walls which may or may not be reinforced. The design of short bridges of this type has been discussed in Chapter IX. Where many culverts are to be constructed, it is common to adopt specific loadings and work out standard forms and dimensions to be used. Such standards have been adopted by many railways and State highway departments. Table XXXI shows dimensions suitable for ordinary highway culverts 5 to 8 feet in span, to carry the loadings used in Section 156. The steel is to be placed 1½ inches from the lower surface of the slab.

*Closed box culverts* of reinforced concrete are frequently used for small openings, as they require less headroom than arched openings and are easily applied when openings are too large for convenient use of pipes. The stresses in such a culvert cannot be accurately determined on account of the indeterminate character of the loads. A load applied upon the top of the culvert produces an equal upward thrust upon the bottom of the culvert, as shown in Fig. 98, which causes a moment tending to bend the top and bottom slabs inward and the sides outward.

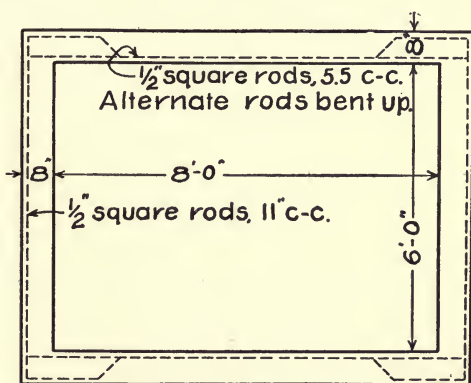

FIG. 98.

Let  $b$  = width of culvert;  
 $h$  = height of sides;  
 $w$  = uniform load per foot;  
 $M_1$  = bending moment in top and bottom slabs;  
 $M_2$  = bending moment at middle of sides;  
 $M_3$  = bending moment at corners;  
 $I_1$  = moment of inertia of sections of top and bottom;  
 $I_2$  = moment of inertia of sections of sides.

If we assume the load to be uniformly distributed over the top, the moments will be as follows:

$$M_1 = \frac{wb^2}{8} \cdot \frac{b/3I_1 + h/I_2}{b/I_1 + h/I_2}$$

and

$$M_2 = M_3 = M_1 - wb^2/8.$$

If the sectional area of the sides be made the same as those of the top and bottom, we have

$$M_1 = \frac{wb^2}{8} \cdot \frac{b/3+h}{b+h}.$$

For a square opening this becomes

$$M_1 = wb^2/12$$

and

$$M_2 = M_3 = -wb^2/24.$$

For sizes of culverts commonly used  $wb^2/12$  may be considered the limiting value to which the moment may approximate. The moments in top and bottom slabs are decreased and those in the sides increased as the ratio of height to width is lessened.

The pressure of earth against the sides of the culvert produces moments in the top, bottom and sides of the culvert of opposite sign to those produced by the load upon top of the culvert, and therefore tend to reduce the effect of the top load upon the culvert. Such pressures always exist to some extent, but are not accurately known. It is usual to assume that unit horizontal pressure, when considered, is about one-third the unit vertical pressure. The moments caused by the side pressures will always be much less than those due to the vertical loads and not sufficient to overcome those moments.

If the side pressures be supposed to exist when the vertical loads are not on the culvert, as may be the case with moving loads, the sides will be subject to positive moments and need reinforcing at the inner surfaces.

The existence of side pressures tends to increase the negative moments at the corners, and a box culvert can act as a whole only when the corners are reinforced sufficiently to carry these moments without cracking at the corners.

In case the fill upon the culvert is not sufficient to distribute the load over the whole top of the culvert, the moment will be increased. For a concentrated load at the middle of span, the moments will be about double those for the same total load distributed over the span. In highway culverts which are covered only with the thickness of the road surface, the distribution of the load may be considered as in Art. 41. In such culverts, the live load should be increased 25 per cent to allow for impact.

When, as is sometimes the case, the corners of the culvert are not reinforced for negative moment, the top becomes a simple beam, resting upon the sides but not rigidly attached to them, and the sides carry only the horizontal earth pressure as simple beams. Such



construction is shown in Fig. 99, which represents a standard section for a highway culvert designed to carry a 20-ton auto truck. The section in Fig. 98 is designed for the same loading.

**181. Arch Culverts.**—

For locations where sufficient headroom is available, arch culverts are often preferable to those with flat top. Very pleasing and artistic effects may frequently be obtained by careful design of arches for such use. Under fills of considerable height, arch culverts will commonly be more economical to construct than slab top culverts.

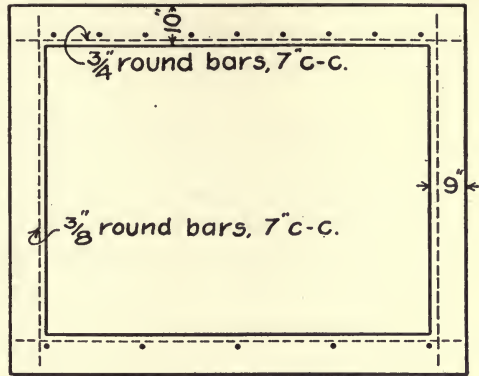

FIG. 99.—Section for Highway Culvert.

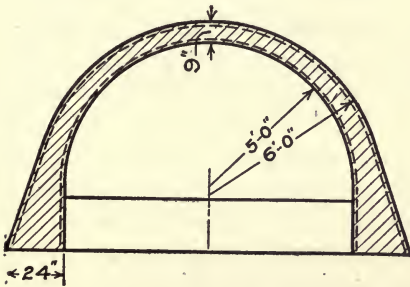

FIG. 100.

Under fills of considerable height, arch culverts will commonly be more economical to construct than slab top culverts. Fig. 100 shows a section for a standard highway culvert for use under automobile traffic.

The analysis of stresses in arch culverts may be made in the same manner as is given for arch bridges in Chapter X. The horizontal earth pressures on the sides of the arch are usually taken as one-third of the vertical pressures at the same point. These pressures are of greater relative importance than in

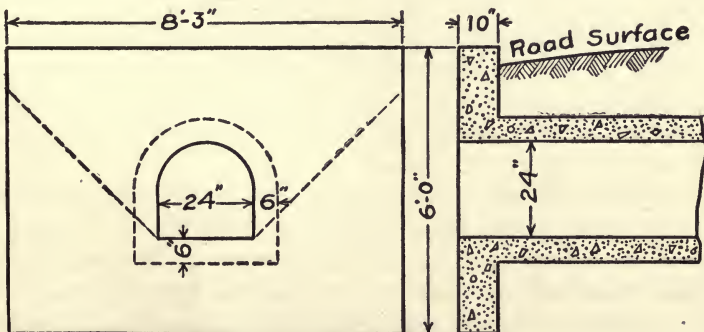

FIG. 101.—Concrete Barrel Culvert.

bridges of longer span. For short spans, plain concrete is commonly employed, while for spans greater than about 8 feet, reinforcement is usually introduced for greater security, although not necessary to carry moments.

#### ART. 51. CONDUITS

**182. Types of Conduits.**—Conduits for carrying water may be designed either for gravity flow or for internal pressure. Brick masonry was formerly largely used in the construction of gravity conduits, particularly for larger sewers, but is now being replaced for the most part by the use of concrete. For conduits to carry water under pressure, reinforced concrete or steel pipe is usually employed.

A conduit consists essentially of two parts, the invert, which forms the channel for the water, and the top, usually arched, which covers the channel and carries the weight of earth or other loads which may come upon it. The shape of the invert depends upon the requirements of the service. In sewers, special forms of invert are frequently needed to prevent deposits at times of minimum flow. The designs of sections for various uses may be found in works upon water supply, irrigation, and sewerage.

Sewage may sometimes cause disintegration of concrete, and the inverts of conduits intended to carry sewage are therefore commonly lined with vitrified brick—a method particularly desirable where the sewage is stale or impregnated with chemicals from manufacturing plants. In conduits carrying water for irrigation, injury to concrete may result from alkalis in the soil unless special precautions are taken.

The inverts of carefully constructed concrete conduits usually resist the abrasion of flowing water fully as well as those with brick or stone lining—such resistance depending upon the alignment of the conduit and the amount of sediment carried by the water. With clear water and an undisturbed flow, very high velocities may produce no appreciable damage, while the impact caused by changes in the direction of flow cause rapid wear, particularly when sand and gravel are carried by the stream.

No conduit is absolutely water-tight, and careful attention should always be given to reducing leakages to a minimum. Usually the most serious leakage occurs at joints where one section joins another, although there will generally be some porous spots through which small quantities of water may pass. The leakage may commonly be reduced to very small proportions by careful design and construc-

tion, reinforcing so as to prevent cracks and using dense and uniform mixtures of concrete. This subject is discussed in Art. 23.

Conduits of small size are sometimes made rectangular in section and designed in the same manner as rectangular culverts. Larger conduits are usually of curved form with arched tops.

**183. Design of Gravity Conduits.**—After determining the size and general shape of conduit required for a given service, the design depends upon the character of the soil upon which it is to be placed and the external loads that it must carry. When the invert rests upon a firm foundation, capable of supporting the structure without sensible yielding, the invert may be considered as fixed in position and the arch may be designed with ends fixed upon the sides of the invert. The design of such arches may be made by the ordinary method used

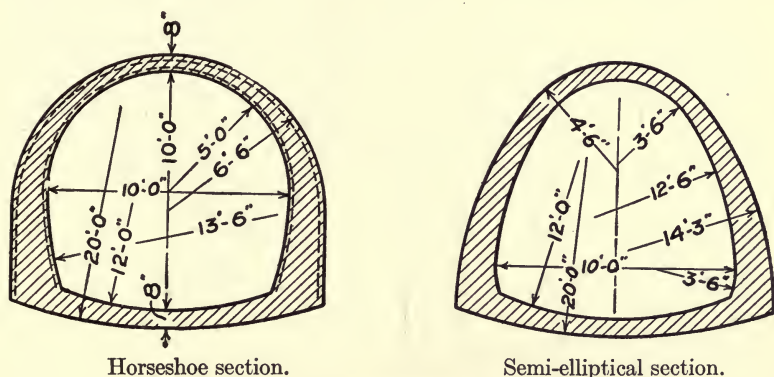

FIG. 102.—Typical Sewer Sections.

for arch bridges or culverts. Actual loads, in so far as they can be determined, should be used in such designs. Where the loads are light, such conduits may often be built of plain concrete; usually, however, it is preferable to reinforce arches of more than 4 or 5 feet span. Fig. 102 shows typical forms of standard sewer conduits.

The horizontal earth pressure to which the side of a conduit may be exposed cannot be accurately determined. It is customary to use Rankine's minimum value,

$$\text{unit horizontal pressure} = w \frac{1 - \sin \phi}{1 + \sin \phi}$$

in which  $w$  is the unit vertical pressure and  $\phi$  is the angle of friction of the earth. Taking  $\phi = 30^\circ$  for ordinary earth, this makes the unit horizontal pressure at any point equal to one-third of the unit vertical



pressure at the same point. In some instances it may be necessary to consider the possible effect of variations in horizontal pressures.

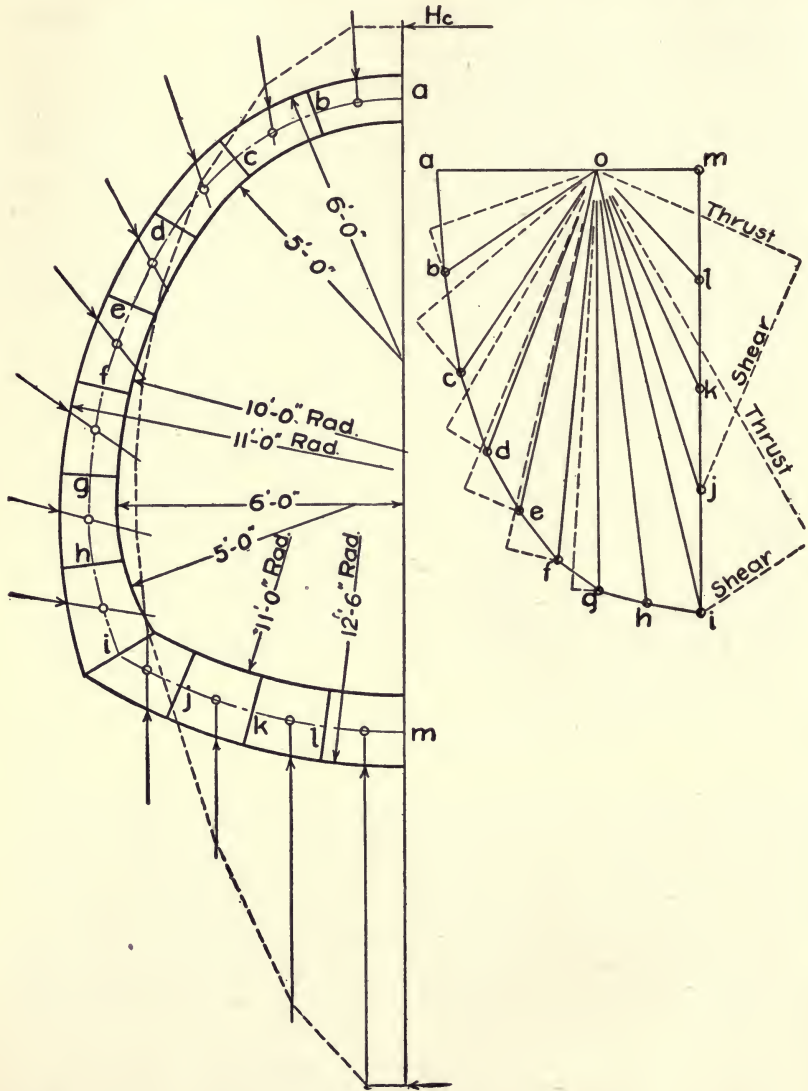

FIG. 103.

As the tendency of such a structure under vertical loading is to deflect outward upon the sides, it is reasonable to assume that at least this minimum horizontal pressure may always be depended upon, or a

TABLE XXXII.—LOADS UPON CONDUIT RING ONE FOOT LONG

| Division.  | VERTICAL LOADS.             |                        |                         |                            | HORIZONTAL LOADS.           |                      |                            | SUM OF LOADS.     |                     |
|------------|-----------------------------|------------------------|-------------------------|----------------------------|-----------------------------|----------------------|----------------------------|-------------------|---------------------|
|            | Earth, lb./ft. <sup>2</sup> | Horizontal Area. Feet. | Weight of Arch. Pounds. | Total on Division. Pounds. | Earth, lb./ft. <sup>2</sup> | Vertical Area. Feet. | Total on Division. Pounds. | Vertical. Pounds. | Horizontal. Pounds. |
| <i>a-b</i> | 2020                        | 2.00                   | 288                     | 4328                       | 673                         | 4.00                 | 269                        | 4,300             | 00                  |
| <i>b-c</i> | 2085                        | 1.85                   | 288                     | 4145                       | 695                         | 0.90                 | 625                        | 4,328             | 269                 |
| <i>c-d</i> | 2205                        | 1.35                   | 288                     | 3265                       | 735                         | 1.50                 | 1102                       | 8,473             | 894                 |
| <i>d-e</i> | 2340                        | 0.95                   | 291                     | 2514                       | 780                         | 1.75                 | 1365                       | 11,738            | 1,996               |
| <i>e-f</i> | 2550                        | 0.70                   | 296                     | 2081                       | 850                         | 1.85                 | 1573                       | 14,252            | 3,361               |
| <i>f-g</i> | 2735                        | 0.35                   | 317                     | 1274                       | 912                         | 1.95                 | 1778                       | 16,333            | 4,934               |
| <i>g-h</i> | 2935                        | 0.08                   | 346                     | 581                        | 978                         | 2.05                 | 2005                       | 17,607            | 6,712               |
| <i>h-i</i> | 3150                        | 0.00                   | 432                     | 432                        | 1050                        | 2.10                 | 2205                       | 18,188            | 8,717               |
| <i>i-j</i> | -2698                       | 1.90                   |                         | -5126                      |                             |                      |                            | 18,620            | 10,922              |
| <i>j-k</i> | -2698                       | 1.60                   |                         | -4322                      |                             |                      |                            | 13,494            | 10,922              |
| <i>k-l</i> | -2698                       | 1.65                   |                         | -4452                      |                             |                      |                            | 9,172             | 10,922              |
| <i>l-m</i> | -2698                       | 1.75                   |                         | -4720                      |                             |                      |                            | 4,720             | 10,922              |

greater passive pressure if needed. In case of soft, wet earth, the horizontal pressure will be much greater, reaching a maximum when it is practically fluid and exerts normal pressure at all points.

Conduits to be supported upon compressible soil are often designed to act as a whole, assuming that all parts of the structure, including the invert, are equally subject to distortion under the loads. Fig. 103 represents a half-section of a conduit of this character. If we assume the middle of the invert,  $m$ , to be fixed in position, the moments and thrusts in a slice of the conduit 1 foot thick may be found in the manner used for the elastic arch in Chapter X. The axis of the conduit ring is divided into lengths as shown. The lengths of the divisions, coordinates of the centers of divisions with reference to the crown, and thicknesses of concrete at centers of division, are given in Table XXXIII.

The loads given (Table XXXII), are those due to the pressure of 20 feet of earth above the crown of the arch. The weight of the earth is taken at 100 pounds per cubic foot, and the intensity of the horizontal earth pressure at one-third that of the vertical pressure at the same point. In computing the loads, the unit pressures at the middle of the extrados of the division are considered as acting upon areas equal to the horizontal and vertical projections of the extrados of the divisions. The upward pressures upon the base are considered as acting vertically and uniformly distributed horizontally. The computations of loads and their moments about the centers of division are shown in Table XXXII.

The moment and thrust at the crown section,  $a$ , may be obtained by the use of the formulas of Section 176. As the loading is symmetrical about the crown,  $m_L$  and  $m_R$  are equal,  $V_c = 0$ , and Formulas (33) and (35) of Section 176 become

$$H_c = \frac{\sum m y \frac{s}{I} \sum \frac{s}{I} - \sum m \frac{s}{I} \sum y \frac{s}{I}}{\sum y^2 \frac{s}{I} \sum \frac{s}{I} - \left( \sum y \frac{s}{I} \right)^2},$$

and

$$M_c = \frac{\sum m \frac{s}{I} - H_c \sum y \frac{s}{I}}{\sum \frac{s}{I}}.$$

Table XXXIII gives the computation of the terms needed in these formulas. As the sections are rectangular, no reinforcement being considered in the computations, the value  $s/t^3$  may be used in the formulas in place of  $s/I$ .



TABLE XXXIII.—COMPUTATIONS OF TERMS USED IN FORMULAS

| Division.  | $x$  | $y$   | $t$  | $s$  | $\frac{s}{t^3}$ | $y\frac{s}{t^3}$ | $y^2\frac{s}{t^3}$ | $m$    | $m\frac{s}{t^3}$ | $my\frac{s}{t^3}$ |
|------------|------|-------|------|------|-----------------|------------------|--------------------|--------|------------------|-------------------|
| <i>a-b</i> | 0.93 | 0.08  | 1.00 | 1.92 | 1.92            | 0.15             | 0.0                | 00     | 00               | 00                |
| <i>b-c</i> | 2.72 | 0.68  | 1.00 | 1.92 | 1.92            | 1.20             | 0.8                | 7,908  | 15,183           | 10,324            |
| <i>c-d</i> | 4.22 | 1.90  | 1.00 | 1.92 | 1.92            | 3.65             | 6.9                | 21,708 | 41,679           | 79,190            |
| <i>d-e</i> | 5.28 | 3.43  | 1.01 | 1.92 | 1.86            | 6.38             | 21.9               | 37,204 | 69,199           | 237,353           |
| <i>e-f</i> | 6.10 | 5.13  | 1.03 | 1.92 | 1.76            | 9.03             | 46.3               | 53,604 | 94,343           | 483,980           |
| <i>f-g</i> | 6.55 | 6.92  | 1.10 | 1.92 | 1.44            | 9.96             | 68.9               | 69,786 | 100,492          | 695,405           |
| <i>g-h</i> | 6.68 | 8.82  | 1.20 | 1.92 | 1.11            | 9.79             | 86.3               | 84,827 | 94,158           | 830,474           |
| <i>h-i</i> | 6.40 | 10.67 | 1.48 | 1.92 | 0.59            | 6.30             | 67.2               | 95,862 | 56,558           | 603,794           |
| <i>i-j</i> | 5.42 | 12.00 | 1.50 | 1.64 | 0.49            | 5.88             | 70.6               | 92,140 | 45,149           | 541,788           |
| <i>j-k</i> | 3.92 | 12.04 | 1.50 | 1.64 | 0.49            | 6.19             | 78.2               | 78,889 | 38,656           | 488,611           |
| <i>k-l</i> | 2.40 | 13.07 | 1.50 | 1.64 | 0.49            | 6.40             | 83.6               | 70,081 | 34,340           | 448,824           |
| <i>l-m</i> | 0.83 | 13.25 | 1.50 | 1.64 | 0.49            | 6.50             | 86.3               | 64,855 | 31,779           | 421,697           |
|            |      |       |      |      | 14.48           | 71.43            | 617.0              |        | 621,536          | 4,841,440         |

Substituting in the formulas, we have

$$H_c = \frac{4841440 \times 14.48 - 621536 \times 71.43}{617 \times 14.48 - (71.43)^2} = 6710 \text{ pounds.}$$

$$M_c = \frac{621536 - 6710 \times 71.43}{14.48} = 9830 \text{ ft.-lb.}$$

$$e = \frac{M_c}{H_c} = \frac{9830}{6710} = 1.46 \text{ feet.}$$

The load diagram is now drawn as shown, and the equilibrium polygon (or line of resistance) constructed, beginning with  $H_c$  at a distance,  $e = 1.46$  feet, above the middle of the crown section.

The thrusts acting upon the ends of divisions as found from the load diagram may be resolved into normal thrusts and shears as shown by the broken lines. These are tabulated in Table XXXIV. The moments at the centers of sections at the end of divisions may be obtained by multiplying the normal thrust upon the section by the distance from the center of section to the point at which the equilibrium polygon cuts the section, or they may be computed by Formula 10 of Section 163, which becomes for symmetrical loading

$$M = M_c + H_c y - m.$$

Table XXXIV, gives the thrusts and moments with the resulting stresses at the extrados and intrados of the sections. These results show that there are tensions at the intrados of the crown section and in the invert, and at the extrados of sections  $f$ ,  $g$ , and  $h$  which must be cared for by reinforcement. This reinforcement should be sufficient to carry the tensions in the section without materially changing the position of its neutral axis or the compression upon the concrete. To do this, the stress in the steel should be limited to about fifteen times that shown for the rectangular section, or about 6000 lb./in.<sup>2</sup> at sections  $a$  and  $g$  and 9000 lb./in.<sup>2</sup> at  $m$ . Computing the total tension in these sections, we find that an area of about 2 in.<sup>2</sup> of steel per foot of length is required at  $a$  and  $g$  and about 4 in.<sup>2</sup> at  $m$ . One-inch square bars spaced 6 inches apart near the intrados at sections  $a$  and  $b$ , then crossing to the extrados at  $e$  and extending along the extrados to section  $i$ , with 1 $\frac{3}{8}$ -inch square bars spaced 6 inches apart near the intrados of the invert would answer the requirement.

The maximum shear occurs at section  $j$ , the unit shear being about 50 lb./in.<sup>2</sup>, which is not excessive.

TABLE XXXIV.—COMPUTATION OF STRESSES

| Section. | $e$   | Normal Thrust. | Bending Moment. | $f_c$ at Extrados.<br>Lb./in. <sup>2</sup> | $f_c$ at Intrados.<br>Lb./in. <sup>2</sup> | Total Tension.<br>Lb. | Shear.<br>Lb. | Unit Shear.<br>Lb./in. <sup>2</sup> |
|----------|-------|----------------|-----------------|--|--|-----------------------|---------------|-------------------------------------|
| <i>a</i> | +1.46 | 6,710          | +9,830          | +457                                       | -363                                       | 11,573                | 00            |                                     |
| <i>b</i> | +1.05 | 7,500          | +7,875          | +380                                       | -276                                       |                       | 1,970         |                                     |
| <i>c</i> | +0.35 | 9,910          | +3,368          | +195                                       | -85  |                       | 3,000         | 21                                  |
| <i>d</i> | -0.20 | 12,540         | -2,508          | -17  | +191                                       |                       | 2,110         |                                     |
| <i>e</i> | -0.50 | 14,280         | -7,140          | -189                                       | +383                                       |                       | 2,670         |                                     |
| <i>f</i> | -0.75 | 16,220         | -12,165         | -344                                       | +556                                       | 9,906                 | 2,440         |                                     |
| <i>g</i> | -0.85 | 17,450         | -14,831         | -358                                       | +568                                       | 11,460                | 1,450         |                                     |
| <i>h</i> | -0.90 | 18,120         | -16,308         | -303                                       | +497                                       |                       | 1,310         |                                     |
| <i>i</i> | -0.75 | 18,500         | -13,875         | -152                                       | +312                                       |                       | 4,550         |                                     |
| <i>j</i> | +0.60 | 9,200          | +5,520          | +113                                       | -47  |                       | 10,690        | 49                                  |
| <i>k</i> | +3.25 | 6,480          | +21,090         | +420                                       | -360                                       |                       | 7,690         | 36                                  |
| <i>l</i> | +6.20 | 4,820          | +29,844         | +575                                       | -531                                       |                       | 4,120         |                                     |
| <i>m</i> | +8.05 | 4,212          | +33,906         | +648                                       | -608                                       | 32,332                | 00            |                                     |



It seems probable that this analysis represents the conditions giving the maximum stresses possible in the structure. For a depth as great as 20 feet, the full pressure of the earth would probably not be borne by the structure. For greater depths, these pressures need not be increased, unless the earth is unstable.

The deflection of the conduit under the loads is outward upon the sides, and, if the earth is well packed around the sides of the conduit the earth will resist that deflection and the horizontal earth pressures will probably be greater than those used in the analysis. This will diminish the bending moments at all points and reduce the need for reinforcement.

Longitudinal reinforcement is needed to prevent cracking of the concrete. Usually  $\frac{1}{2}$ -inch bars, 12 inches apart, are sufficient for this purpose. Where the support of the soil under the conduit may not be uniform, it is desirable to guard against longitudinal deflection by the use of heavier reinforcement near the bases of the side walls.

**187. Pressure Conduits.**—Conduits to carry water under pressure are usually made of circular or oval form. The stresses caused by internal pressure are all tensile and should be taken wholly by the steel reinforcement.

- Let  $P$  = the internal pressure per square inch;  
 $D$  = the internal diameter of the conduit in inches;  
 $f_s$  = the stress in the steel;  
 $A_s$  = the area of steel per inch of length.

Then we have,  $A_s = PD/2f_s$ . Low values of  $f_s$  are desirable in order to minimize the possibility of cracks in the concrete. Satisfactory results have been obtained in a number of instances with stresses from 10,000 to 15,000 pounds per square inch. The likelihood of cracks will be reduced by using reinforcement giving mechanical bond, such as expanded metal, diagonal mesh or deformed bar, rather close spaced.

The thickness of concrete, except for small conduits under light pressure, should be at least 6 inches. When the pressure is considerable, it may be possible to reduce the possible leakage by use of a greater thickness with double lines of reinforcement and low tension in the steel.

Pressure conduits must be capable, like gravity conduits, of carrying any exterior loads which may come upon them when empty. They may be analyzed in the same manner as pipes or gravity conduits for exterior loadings.

Longitudinal reinforcement is required in conduits to prevent

cracking due to changes in temperature and shrinkage of the concrete. When the conduit is divided into sections by use of expansion joints, light reinforcement may be sufficient between joints, although closer spacing is desirable than is required for longitudinal reinforcement in bridges or culverts. When prevention of leakage is important, and the probable changes in temperature not too great, continuous closely spaced longitudinal reinforcement may give better results than the use of expansion joints.

## CHAPTER XII

### FOUNDATIONS

#### ART. 52. FOUNDATION MATERIALS

**185. Examination of Soil.**—The stability of any structure requires that it be adequately supported by the ground upon which it rests, hence the nature of the soil upon which the structure is to be placed is the first subject for consideration in designing a foundation, and the local conditions under the surface of the ground must be determined. Numerous instances might be cited of the failure of structures due to lack of adequate investigation of soil conditions, and every effort should be made to obtain an accurate knowledge of the underlying strata.

For shallow foundations, *open excavations* may be made to a depth somewhat greater than that of the substructure, which will give the advantage of permitting the examination of the soil through and into which the substructure must be built and observing its condition. When the excavation is in wet material, pumping may be required to keep down the water and perhaps sheeting to prevent the sides caving in—an expensive procedure if excavating is carried to considerable depth.

*Soundings* are sometimes made with a rod, or small pipe about an inch in diameter, which is driven into the ground with a maul. When the material near the surface is soft, the depth to rock or other hard material may usually be determined in this manner if it is not more than 20 or 30 feet. Soundings serve to indicate whether resistance increases or decreases, and the depth at which hard material stops further progress. A number of soundings are usually necessary. A sunken log or boulder may stop the rod, and mistakes in interpreting the results of such soundings are easily made.

*Borings* with earth augers may be easily made for small depths with good results. Ordinary wood augers about 2 inches in diameter have also been used for this purpose, borings 100 feet deep having been made in this manner, though for ordinary work to more moderate depths, the use of earth augers of larger diameters give better deter-



minations. An auger 6 inches in diameter may readily be driven to a depth of 25 or 30 feet by two men with levers. It is held in vertical position by pipes or rods in sections, which may be coupled together as the hole becomes deeper, and is turned by hand with handles at the top 2 to 4 feet long, which are adjustable in position on the rods. The auger is screwed into the soil sufficiently to fill it with earth, and is then brought to the surface and the material examined, giving a good determination of the character of the soil at any depth, but not showing its degree of compactness. When the hole passes through material which will not retain its shape, a casing somewhat larger than the auger is driven, through which the boring may be done. When the depth to which the boring must extend is considerable, a block and fall, supported by a tripod, may be used to draw the auger from the hole.

*Wash borings* may be rapidly driven through soft soil or clay by sinking a casing, with a small pipe or hollow rod inside which carries a jet of water at its lower end. The jet cuts the soil at the bottom and brings up the excavated material through the annular space between the jet pipe and casing. It is usual also to have the bottom of the inside pipe fitted with a bit or chisel, which may aid in cutting into hard material. Both jet pipe and casing are rotated as they descend. When hard material is met, it may be necessary to cut it with the bit by churning the inside pipe. The bottom of the casing is also sometimes flared slightly and fitted with teeth for cutting.

When the depth is not great and only a small amount of work is to be done, ordinary water pipe about 2 inches in diameter is sunk as a casing, a smaller pipe  $\frac{3}{4}$ -inch in diameter being used inside. Hand appliances may be used in handling these pipes, a tripod with block and fall, levers for turning the pipes, and a hand pump for applying pressure to the jet. On more important work hollow rods for holding the jet and bits, special casings, and pipes with flush joints are necessary. These may be controlled by hand, or machine outfits similar to those used in drilling wells may be employed.

Examination of the materials brought up by the water shows the nature of the underlying strata. It does not, however, reveal the moisture or compactness of the material. It may therefore be desirable to obtain cores of the materials as they occur at certain points in the test holes, which may be done by substituting a cylinder for the jet and bit upon the end of the rod and pressing or screwing the cylinder into the soil at the bottom of the hole until it is filled with a sample of the material, which is then drawn to the surface and examined. This may sometimes prevent mistakes in judging of

subsurface conditions where the wet method of excavation is employed.

*Core drills* are used in testing rock strata. These consist of hollow circular bits, which are rotated so as to cut an annular channel into the rock, leaving a circular core on the inside of the core barrel to which the bit is attached. This core is removed at intervals for examination, and furnishes definite information concerning the character of the material. The core barrel is attached to hollow rods through which water may be supplied to cool the bit.

Several types of bits are used for this purpose; in some the cutting edge is formed of black diamonds or bort; in others, chilled shot are used under a hollow soft steel bit; or steel bits with teeth may be employed. When diamond drills are used, the cores are commonly from 1 to 2 inches in diameter; the other types are usually somewhat larger, varying from 2 to 4 inches in diameter.

Chopping bits are often used in connection with core drills, cores being taken at intervals and the intermediate cutting being done by the chopping drills. In any such work, complete drilling machines are necessary and they should be operated by men experienced in the work.

**186. Bearing Capacity of Soils.**—Definite values of bearing capacity for various soils cannot be stated with accuracy, because of the variations in character and condition of the same kind of soils and the consequent difficulty in classifying them. The ability of the soil to sustain loads depends not only upon its character, but also upon the amount of water it contains and the degree to which it is confined in position. The location and drainage of the foundation as well as the character of the soil must therefore be considered in determining its bearing capacity.

*Solid rock* makes the best and most substantial foundation, and usually is capable of carrying any load that the masonry may bring upon it. The loose and decayed portions of the rock upon its surface need to be cut away, and the surface should be trimmed so that there will be no tendency for the structure to slip upon it.

*Clay soils* vary widely in character. They may be found in any condition from soft, wet clay, which will squeeze out laterally under light pressure, to hard, indurated clays capable of bearing heavy foundations without yielding. The supporting power is mainly dependent upon the amount of moisture contained in the clay. The tendency of clay to retain water which it may absorb and to soften as the amount of water increases is its most important property. Clays differ considerably in the readiness with which they absorb

water. Compact, hard clays may by proper drainage usually be kept dry and capable of bearing heavy loads, frequently 8 to 10 tons per square foot, while wet clay may not safely carry more than 1 ton per square foot.

*Sand or gravel and sand* makes a good foundation when confined laterally so that there is no danger of it being washed out, compact gravel and sand being capable of carrying heavy loads without sensible settlement. Water will not soften it, and it is but slightly affected by frost. Loads of 8 or 10 tons per square foot seem to be conservative for such material under favorable conditions. Fine sand when saturated becomes soft and mushy and is easily displaced; it must be confined laterally to form a good foundation. Dry clean sand may carry loads of 2 to 4 tons per square foot, and when cemented with clay and protected from water it may safely carry loads of 4 to 6 tons per square foot.

When the top soil is loam or made land, foundations should go through such materials to natural subsoil beneath.

The thickness of the layer of material in which the foundation is placed and the nature of underlying strata are important factors in determining the supporting power, as well as the character of the foundation material itself. Foundations in hard clay which is soft underneath may sometimes safely carry  $1\frac{1}{2}$  or 2 tons per square foot.

For the foundations of buildings, local conditions usually lead to a standard practice, and the building codes of the various cities are designed to insure safety under the particular circumstances of each place.

The depth of the foundation below the surface of the ground is important in plastic material, the weight of the earth being relied upon to confine the material, and prevent it squeezing out and lifting the surrounding area. Corthell in his "Allowable Pressure on Deep Foundations" has cited a large number of instances showing working loads upon foundations under varying conditions.

The pressures allowed upon foundations by the specifications of various authorities differ quite widely. The values in Table XXXV represent the range of maximum pressures commonly given.

The character of the structure to be carried by a foundation may frequently have an influence upon the choice of a limiting value for the bearing capacity. Where a slight settlement in the foundation may be serious in its effect upon the structure, very conservative pressures should be adopted.

**187. Tests for Bearing Capacity.**—Direct tests of the capacity of the soil to support the loads coming upon a foundation are frequently



desirable, they should be supplemental to the examination of the site and cannot replace such examination. They are intended to give a more accurate idea of the actual bearing capacity than can be derived from observation of the material upon which the foundation is to be placed and its underlying strata, and should therefore be made in the excavation at the level upon which it is proposed to place the base of the foundation.

TABLE XXXV.—SAFE BEARING CAPACITIES OF SOILS

| Material,                                | Safe Bearing Capacity,<br>Tons per Square Foot. |
|--|---|
| Rock, limestone or sandstone . . . . .   | 15 to 30  |
| Rock, soft or shale . . . . .            | 5 to 10   |
| Clay, dry and hard, thick beds . . . . . | 4 to 8  |
| Clay, moderately dry . . . . .           | 2 to 5  |
| Clay, soft . . . . .                     | 1 to 2  |
| Gravel and sand, well cemented . . . . . | 7 to 10   |
| Gravel, coarse . . . . .                 | 5 to 8  |
| Sand, dry and well cemented . . . . .    | 3 to 6  |
| Alluvial and soft soils . . . . .        | 0.5 to 1  |

The methods of making these tests vary considerably. Sometimes a small area is loaded and observations made of the settlement under varying loads, from which the probable safe bearing capacity may be deduced. In other instances, a load of about twice that proposed for the foundation is placed upon a small area and settlement for different periods of time observed, with a view to judging the safety of the proposed loading. Usually a platform is employed to carry the load. The platform is customarily supported on a pier of about 1 square foot area, or sometimes upon four legs at its corners. The soil to be tested is leveled to receive the piers and provision made for observing the settlement of the base of the pier under the loads. The platform must be so arranged as to bring uniform pressure upon the area under test.

The time element is frequently a matter of importance, settlement in some soils occurring gradually during a period of twenty-four or forty-eight hours, until a stable position is reached. Some soils are elastic under working loads, and the settlement diminishes as the load is decreased after a test.

The resistance offered by the soil to pressure upon a small area is not necessarily the same as that which may exist over a large area, and the results of such tests must be used very conservatively in the design of foundations. These results, however, when combined with

careful observations of the character of the materials underlying the foundation, give a basis upon which to form a judgment of safe bearing capacity.

#### ART. 53. SPREAD FOUNDATIONS

**188. Distribution of Loads.**—When bedrock is at considerable depth, it frequently becomes necessary to spread foundations over large areas near the surface of the ground by the use of footings at the bases of columns or walls. The method to be employed in such work depends upon the area of soil required to support the loads and the extent of the footings necessary beyond the bases of the walls or columns. When the extensions are small, masonry footings may often be employed to advantage, and this is the most common type of foundations for light buildings upon firm soil. When footings must extend to greater distances beyond the bases of the walls or piers, grillage or reinforced concrete footings occupy less space and are more economical.

In foundations of this type some settlement is usually to be expected, and the object should be to make this settlement as small and as uniform as possible. The loads to be carried by the different parts of the foundation should be ascertained and the footings so proportioned as to bring uniform pressure upon the soil under the foundation. Inequalities in the settlement of the foundations of buildings are apt to crack the walls, injuring the appearance when not sufficient to impair the stability of the structure. To produce uniform pressure it is necessary that the center of pressure of the load pass through the center of area of the base of the foundation.

In determining the loads which may come upon the footings in the foundation of a building, the dead loads and live loads are separately computed. The entire dead load is always upon the foundation, while the live load may vary, and only such portion as may reasonably be assumed usually to exist should be used in estimating the load distribution upon the footings, which will depend upon the character of the building. In hotels, office buildings, etc., while the floors of each portion should be designed to carry the maximum live load which could come upon it, only a small percentage of the total of this live load can reach the footings at once, and it is common to neglect it altogether. In churches, theaters, etc., the maximum floor loads are more apt to occur, and a larger percentage should be used in designing the foundations. The building codes of the various cities com-

monly prescribe the loads to be used in designing foundations for buildings.

When the exterior walls of a building carry much of its weight, the center of pressure should be somewhat inside the center of the footing, thus avoiding any tendency to tip outward and crack the walls of the structure; a tendency to tip inward will be resisted by the interior walls and floors. The rigid connection of a lightly loaded interior wall with a heavily loaded exterior one often causes an eccentricity of loading in the foundation which produces serious cracks. When a series of openings one above the other through the wall of a building cause the loads to be brought to the foundation through piers between the openings, the footings should be disconnected and properly centered for each pier, unless the foundation has sufficient stiffness in itself to distribute the loads over its whole base. The walls of many buildings are cracked over the openings by the use of continuous foundations in such cases.

**189. Masonry Footings.**—For light loads, footings of brick or stone masonry or of concrete are commonly employed. Where

suitable stone is available, stone masonry is often the most economical, but concrete is now usually preferred. Brick footings are less desirable on account of the likelihood of the deterioration of the bricks when used under ground.

In placing *stone footings*, the stones must be carefully bedded so as to bear evenly upon the foundation soil. The projection of the footing, when of considerable extent, is stepped off as shown

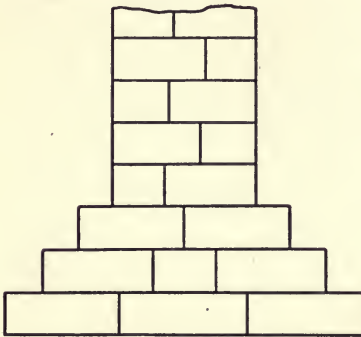

FIG. 104.

in Fig. 104. The width of a step should not ordinarily be greater than two-thirds of the height of the course, and a stone should not project more than one-third of its length beyond the course above. Footing stones under walls carrying heavy loads should be large and roughly squared, and should be set in a thick bed of mortar to give even bearing upon the soil beneath.

*Plain concrete footings* are usually stepped off in the same manner. As the concrete footing is a monolithic structure and capable of carrying small tensile stresses, the projecting step may be considered as a cantilever carrying the upward thrust of the soil upon its lower surface.



- Let  $t$  = the thickness of the footing at any point;  
 $o$  = the projection of the footing beyond the point where the thickness is  $t$ ;  
 $p$  = the pressure in pounds per square foot on the bottom of the footing;  
 $f$  = unit stress upon the concrete due to bending.

Then the allowable projection for any given thickness is

$$o = t\sqrt{48f/p}.$$

Thus, if we assume the safe tension on the concrete to be 60 lb./in.<sup>2</sup>, and the pressure upon the foundation soil as 2 tons per square foot,  $o = .85t$ , or the projection should not be greater than .85 of its thickness.

The projections for cut stone in which each stone is the full height of the course may be estimated by the above formula, provided the stones may be considered as firmly held in place under the wall. When placed upon compressible soil, however, the pressure will not be uniformly distributed over the base of the stone, and there is likelihood of tipping the block if the projection is too great.

Under brick walls, a bed of concrete is usually employed at the base and the brickwork stepped off on top of this to give the required extensions. The offsets in such work should not be more than three-quarters of their heights, which may be composed of two courses of brick.

**190. Grillage Foundations.**—When a foundation must be spread over an area which is large compared to that of the column or wall resting upon it, a masonry footing becomes uneconomical and a footing possessing greater transverse strength and requiring less height becomes desirable. For such foundations, grillages of timber or steel or reinforced concrete slabs are commonly employed.

*Steel I-beam grillages* are now very frequently used under heavy buildings. The construction of foundations of this type was begun in Chicago about 1880. In founding heavy buildings upon the clay subsoil, it was necessary to spread the footings over considerable areas, and room was not available for masonry footings, as the subsoil was soft at greater depths. A footing consisting of several layers of old steel rails encased in concrete was devised and used for some time. This was soon replaced by I-beams of sufficient depth to carry the loads in a single layer, thus saving space and giving better economy in the use of the metal.

A grillage footing as applied to the foundation of a single column is

shown in Fig. 105. Such foundations rest upon a bed of concrete

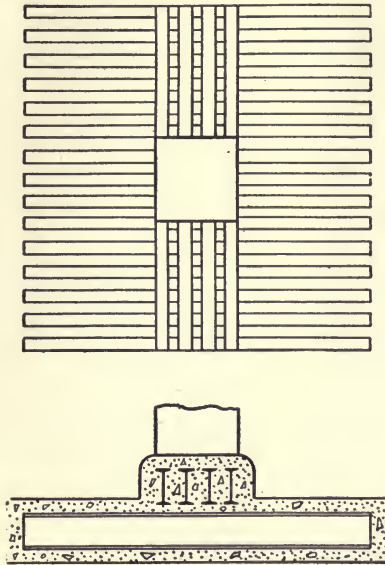

FIG. 105.

and are enclosed by a filling and surfacing of concrete for the protection of the steel. Under heavy loads, the bed of concrete is usually about 12 inches thick and the protective coating from 3 to 6 inches thick. The beams should be held by spacers at least 3 inches apart in the clear in order to permit filling the spaces with concrete. Under a continuous wall, a block of plain concrete is usually employed instead of the upper series of I-beams.

In designing a grillage footing, the loads to be carried and the areas of the walls or piers are known and the grillage must be so placed as to bring the center of its area in the line of action of the resultant load.

The total load may be considered as distributed uniformly over the base, giving uniform upward pressure upon the beams, while the downward

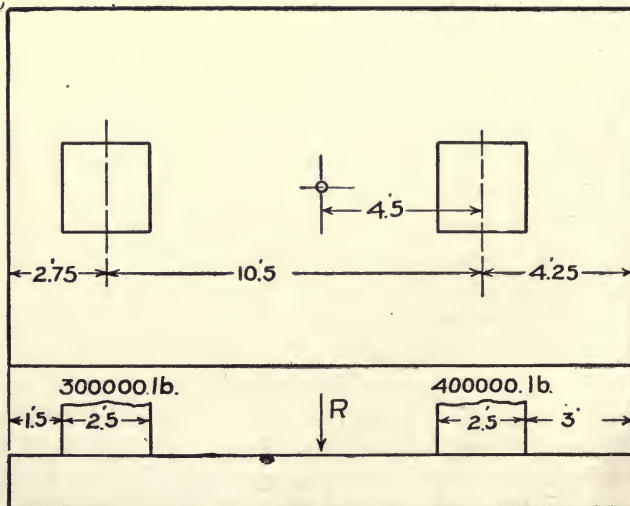

FIG. 106.

thrust of a pier is taken as uniformly distributed over its section. Usually a grillage is centered under each column or wall, proportioned to the load to be carried, but two or more loads may be carried by a single grillage when it seems desirable.

Fig. 106 shows a footing supporting two piers each 2.5 feet square, one carrying a load of 300,000 pounds and the other 400,000 pounds, spaced 10.5 feet between centers. The soil pressure is limited to 4000 lb./ft.<sup>2</sup> and an area of 175 ft.<sup>2</sup> is required. If this area be assumed as 17.5 feet by 10 feet as the center of gravity of the loads is 4.5 feet from the center of the pier carrying the larger load, the piers will occupy the positions shown, when the pressure is uniform upon the soil.

The upper tier of beams under the heavier load carries 400,000 pounds distributed over 2.5 feet at the middle acting downward on its upper surface, and the same load distributed uniformly over the length of 10 feet, acting upward on its lower surface. The maximum moment will be at the mid-section and will be

$$M = 200000 \times 5/2 - 200000 \times .625 = 375000 \text{ lb.-ft.}$$

If the allowable unit stress in the steel is 16,000 lb./in.<sup>2</sup>,

$$I/e = 375000 \times 12/16000 = 281 \text{ in.}^2, \text{ and we might use}$$

2—24-in. 80 lb. I-beams,  $I/e$  173.9 each, flange 7 in. wide

2—20-in. 80 lb. I-beams,  $I/e$  146.6 each, flange 7 in. wide

3—18-in. 60 lb. I-beams,  $I/e$  93.5 each, flange 6.1 in. wide

The 20-inch beams require less concrete than the 24-inch, and less steel than the 18-inch and may be used, although the spacing is rather wide. The flanges are spaced 10 inches apart and 3 inches inside the block of concrete.

Under the load of 300,000 pounds,  $I/e$  should be 210 in.<sup>3</sup>, and two 20-inch 65-pound I-beams may be used.

The lower tier of beams carries two loads of 400,000 and 300,000 pounds respectively, acting downward upon its upper surface, each distributed over 2.5 feet as shown, and a load of 4000 pounds per square foot uniformly distributed over its lower surface. There are sections of maximum moment under each load and at some point between them. These sections are where the shear passes through zero. Let  $y$  = distance from end of beam to section. Under the heavier load, the shear is



$$4000 \times 10y - \frac{400000}{2.5}(y-3) = 0, \text{ and } y = 4.$$

Then

$$M = 4000 \times 10 \times \frac{4^2}{2} - \frac{400000}{2.5} \times \frac{(4-3)^2}{2} = 240000 \text{ lb.-ft.}$$

For the mid-section,  $4000 \times 10y - 400,000 = 0$ , and  $y = 10$ .

Then

$$M = 4000 \times 10 \times 10 \times 10 / 2 - 400000(10 - 4.25) = -300000 \text{ lb.-ft.}$$

The greatest moment is 300,000 lb.-ft. or 3,600,000 lb.-in., and the required  $I/e$  is  $3,600,000/16,000 = 225 \text{ in.}^2$

Eleven 6-in. 12.25-pound I-beams,  $I/e = 21.8$  each, flange 3.33 inches wide, clearance 8.4 inches may be used. Three or four additional beams may be introduced if thought desirable to reduce the clearance. If this is not done, light transverse reinforcement might be placed in the concrete covering the beams.

The moments might be somewhat decreased and the positive and negative moments made more nearly equal by making the foundation narrower upon the end carrying the smaller load and widening the other end. The same steel area would then be needed at both ends and the spaces between the beams would widen from one end to the other.

It may frequently be convenient to carry three or more piers or columns upon one grillage. In such a design, the line of action of the resultant of all the loads must pass through the center of area of the grillage. Two loads are usually carried upon one set of the upper tier of beams, which is arranged to give uniform loading to the tier below at right angles to it.

*Timber grillages* may be employed where the footing is so located as to be continually wet. They are also commonly used for temporary footings which are to be removed in a comparatively short time. These foundations are usually constructed by placing a layer of 2-inch planks on the bed to be occupied by the footing and across these one or more series of timbers in the same manner that the I-beams are used in the steel grillages. The timbers must be capable of carrying the bending moments due to transmitting the loads from the walls or piers to the soil upon which the footing rests. On top of the grillage a floor, usually of 3-inch plank, is placed to carry the base of the masonry. All timber in such foundations must be kept below low water and the spaces between the timbers should be filled with sand or broken stone.

**191. Reinforced Concrete Footings.**—Reinforced concrete slabs

are ordinarily used as footings for the distribution of loads in spread foundations. When used under walls, these consist of a cantilever projecting on each side of the wall; the determination of thickness and amount of reinforcement is made as for a simple cantilever. When used under columns or piers, the load may be transmitted to the slab through beams, or flat slabs with two-way or four-way reinforcement may be employed.

When beams are used, the moments may be computed by the methods used for I-beam grillages and reinforced concrete beams and slabs with one-way reinforcement designed to resist these moments in the usual manner. If the construction is monolithic, the maximum stresses occur in the sections where the slabs join the beams and in the beams where they join the base of the pier. The stresses in such foundations may be accurately computed in so far as the loads are known, and they are not subject to the assumptions required in the flat-slab computations. Usually these footings are cheaper in cost of materials than flat-slab footings, but require more form work in construction.

In a flat-slab footing with two-way reinforcement, the maximum moment in the slab occurs in the sections through the face of the pier. In the footing shown in Fig. 107, it is assumed that the section through each face carries the moment between that face and the side of the footing. Thus, the moment of the upward pressures on the area  $ABCD$

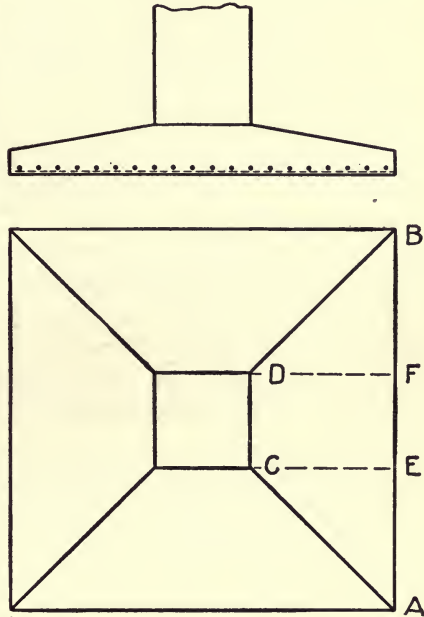

FIG. 107.

is supposed to be borne by the section  $C-D$ . These moments are not uniformly distributed over the section, but must be greater in the portion between  $C$  and  $D$  than in its ends. From experiments made at the University of Illinois, Professor Talbot<sup>1</sup> concludes that "For footings having projections of ordinary dimensions, the critical section for the bending moment for one direction

<sup>1</sup> Bulletin No. 67, Engineering Experiment Station, Univ. of Ill.

(which in two-way reinforced concrete footings is to be resisted by one set of bars) may be taken to be at a vertical section passing through the face of the pier. In calculating this moment, all the upward load on the rectangle lying between a face of the pier and the edge of the footing is considered to act at a center of pressure located at a point halfway out from the pier, and half of the upward load on the two corner squares is considered to act at a center of pressure located at a point six-tenths of the width of the projection from the given section.

“With two-way reinforcement evenly spaced over the footing, it seems that the tensile stress is approximately the same in bars lying within a space somewhat greater than the width of the pier and that there is also considerable stress in the bars which lie near the edges of the footing. For intermediate bars, stresses intermediate in amount will be developed. For footings having two-way reinforcement spaced uniformly over the footing, the method proposed, for determining the maximum tensile stress in the reinforcing bars, is to use in the calculation of resisting moment at a section at the face of the pier the area of all the bars which lie within a width of footing equal to the width of pier plus twice the thickness of footing, plus half the remaining distance on each side to the edge of the footing. This method gives results in keeping with the results of tests. When the spacing through the middle of the width of the footing is closer, or even when the bars are concentrated in the middle portion, the same method may be applied without serious error. Enough reinforcement should be placed in the outer portion to prevent the concentration of tension cracks in the concrete and to provide for other distribution stresses.

“The method for calculating maximum bond stress in column footings having two-way reinforcement evenly spaced, or spaced as noted in the preceding paragraph, is to use the ordinary bond-stress formula, and to consider the circumference of all the bars which were used in the calculation of tensile stress, and to take for the external shear that amount of upward pressure or load which was used in the calculation of the bending moment at the given section.”

*Example.*—A column 2 feet square is to carry a load of 300,000 pounds on soil that may safely carry 3000 pounds per square foot. It is required to design a square footing with two-way reinforcement, using concrete of 2000 pounds compressive strength and unit stress of 16,000 lb./in.<sup>2</sup> upon the steel.

The required area of footing is  $300000/3000 = 100$  square feet. A base 10 feet square will be used.



The thickness of footing required for shear at base of column is

$$t = \frac{300000 - 4 \times 3000}{4 \times 24 \times 120} = 25 \text{ inches.}$$

Using Talbot's rule, the moment of the load upon *DCEF* (Fig. 107) is  $2 \times 4 \times 3000 \times 2 \times 12 = 576000$  in.-lb.; that of the loads *DFB* and *ACE* is  $4 \times 4 \times 3000 \times 2.4 \times 12 = 1382400$  in.-lb.

Total,  $M = 576000 + 1382400 = 1958400$  in.-lb.

The effective width of section is  $2 + 2.1 \times 2 + 1.9 = 8.0$  feet.

The depth required for moment is (Formula (9) Chapter VI)

$$d = \sqrt{\frac{M}{Rb}} = \sqrt{\frac{1958400}{108 \times 96}} = 14 \text{ inches.}$$

If we use the depth of 25 inches,

$$A_s = \frac{M}{f_s j d} = \frac{1958400}{16000 \times .875 \times 25} = 5.6 \text{ in.}^2$$

Nineteen  $\frac{5}{8}$ -inch bars in the width of 8 feet gives an area of 5.8 in.<sup>2</sup> and a spacing of about 5 inches. Four additional bars or 23 in all should be used in the full width of 10 feet.

The maximum shear is equal to the load upon the area *ABDC*,

$$\frac{300000 - 4 \times 3000}{4} = 72000 \text{ pounds,}$$

and the bond stress is

$$u = \frac{V}{\Sigma o j d} = \frac{72000}{19 \times 1.96 \times .875 \times 25} = 88 \text{ lb./in.}^2$$

This is rather high for plain bars, but deformed bars may be used.

According to Talbot's rules, the shear for diagonal tension may be computed on a section distant the depth of footing from the base of the pier, which will give a shear

$$V = [(10)^2 - (2 + 2 \times 2.1)^2] 3000 = 184680 \text{ pounds,}$$

and a unit shear

$$v = 184680 / [4(24 - 2 \times 25) \times .875 \times 25] = 29 \text{ lb./in.}^2$$

and no diagonal tension reinforcement is necessary.

The volume of concrete in the above footing may be decreased by widening the base of the pier or placing a block of concrete under it as shown in Fig. 108. If a step 6 inches wide be used, making the block 3 feet square, the depth of footing required is found to be 16

inches. Reinforcement for diagonal tension would be required for this depth but by increasing it to 17 inches, the shear may be so reduced as to make this unnecessary. This change would decrease the volume of concrete required by about 30 per cent and increase the weight of steel by 20 to 25 per cent.

*Four-way Reinforcement.*—When a four-way reinforcement is used, each set of bars is supposed to carry an equal share of the moment. As the length of the diagonal bars are not the same as those parallel to the sides of the footing, this supposition is only approxi-

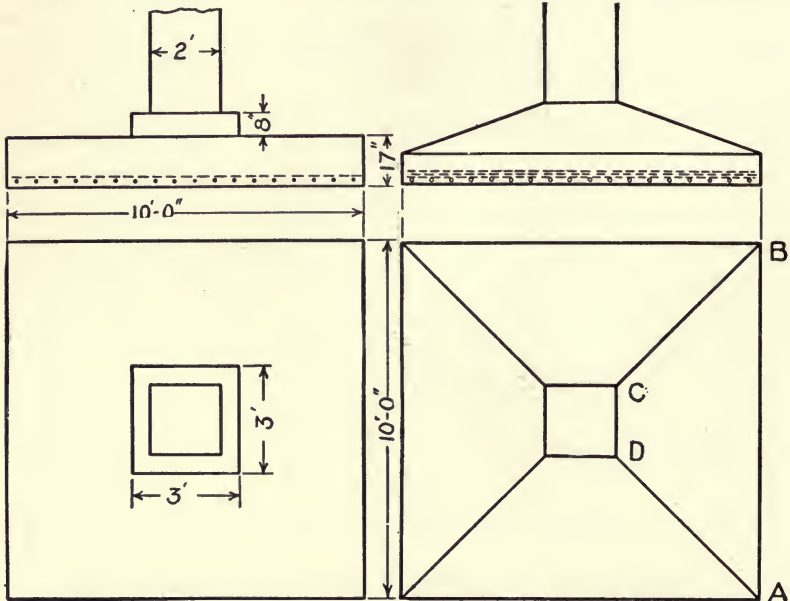

FIG. 108.

FIG. 109.

mately correct, but in the absence of more definite information concerning the distribution of stress it may be used in design.

If a four-way reinforcement be used in the example already given, as shown in Fig. 109, the depth required for shear at the base of the pier will be as before, 25 inches. The moment of the upward thrust upon the area  $ABCD$  about the section  $CD$  is, as before, 1,958,400 in.-lb. If the width of section be supposed to carry all of the compression due to this moment, the depth of section required will be

$$d = \sqrt{\frac{M}{Rb}} = \sqrt{\frac{1958400}{108 \times 24}} = 28 \text{ inches.}$$

The depth to the steel will be made 28 inches at the base of the pier and slope to 6 inches at the edges of the slab, thus giving greater depth than necessary at all intermediate points.

$$A_s = \frac{M}{f_s j d} = \frac{1958400}{16000 \times .875 \times 28} = 5.0 \text{ in.}^2$$

Sixteen  $\frac{9}{16}$ -inch square bars may be used. The maximum bond stress will be

$$u = \frac{V}{\Sigma o j d} = \frac{72000}{16 \times 2.5 \times .875 \times 28} = 74 \text{ lb./in.}^2$$

Eight bars will be placed parallel to the edge of the footing and eight on the diagonal in each direction; they may cover a greater width than the base of the pier, and will be spaced 5 inches apart, thus making each band 3 feet wide and covering the whole area in a satisfactory manner.

The method for diagonal tension in a slab of this form has not been satisfactorily worked out. If we apply the method proposed by Professor Talbot for slabs with flat-top surface, we have, on a section distant 28 inches from the base of the pier,

$$V = [(10)^2 - (6.67)^2]3000 = 166600 \text{ pounds,}$$

and

$$v = \frac{166600}{4 \times 80 \times .875 \times 15.2} = 39 \text{ lb./in.}^2;$$

and no diagonal tension reinforcement is necessary. As the section to resist diagonal tension is increased by the slope of the top surface of the beam, it seems reasonable to employ the [method in this instance.

Various modifications of these forms of footing are often employed, depending upon the same principles in design, but varied to suit special needs or to secure greater economy in the use of materials. Ribs may sometimes be used to advantage in distributing the loads upon the slab.

*Cantilever Foundations.*—When it is necessary to carry the side walls or wall columns of buildings upon footings which cannot project beyond the face of the wall on the outside, cantilever footings are often employed, wherein the wall columns rest upon one arm of a cantilever beam, the other arm of which carries an interior column, the cantilever being so proportioned as to center the total load upon the footing which supports it. Footings of this type are often necessary when the loads upon the wall columns are greater than those upon the interior column, so that the ordinary combined footing is



in placing it in position and to raise and lower the hammer in driving. The leads are supported in position by a triangular framework braced with backstays. The platform or deck to which the framework is attached also carries a hoisting engine with friction drums for handling the pile and hammer lines. The general arrangement is shown in Fig. 111. The details of arrangement and method of mounting vary widely according to the service for which the machine is intended.

Pile-drivers may be so mounted as to move forward, backward, and to the side by the use of rollers, or made to turn in any direction by mounting upon a turntable. For river work, they are usually rigidly connected to the deck of a barge which is moved to place the driver in position.

For railway work, drivers are commonly mounted upon cars, and many of them are very carefully designed to render efficient service under varying conditions. The cars are made self-propelling to make the machine independent of locomotive service, and leads which can be quickly raised and lowered are employed. The drivers are mounted upon turntables which permit driving upon either side, and the leads are arranged so that they may be turned to an inclined position for the purpose of driving batter piles. The stability of the machines when driving at the greatest reach from the cars is important and must be carefully considered in design. Combination machines, in which service as pile drivers is added to that as derricks or as excavators are also frequently employed.

*A drop-hammer*, as used in driving piles, usually consists of a solid casting, which is raised by means of a rope and allowed to drop upon the head of the pile. The hammer slides in guides upon the leads and should be so shaped as to give it a low center of gravity and a sufficient length to cause it to slide in the guides without rocking; it may be given a free fall by the use of nippers which engage a pin upon the hammer and are automatically disengaged at a certain height upon the leads. The more common method, however, is to raise and drop the hammer by the use of a hoisting drum with a friction clutch, the rope being permanently attached to the hammer—a more rapid system, which permits the operator to regulate readily the height of fall. The weight of hammer employed in ordinary work varies from about 2000 to 3500 pounds. For light work in small operations, light hammers may be used, while for heavy service and unusual conditions, heavier ones may be necessary. A heavy hammer with low fall is more effective in driving than a light hammer with high fall, as it may be operated more rapidly and causes less vibration in the machine.

A *steam pile-hammer* is one which is raised and dropped by a steam piston working in a cylinder attached to a frame which rests upon the head of the pile. The frame slides in the guides upon the leads, and the striking part or hammer is guided by the frame. In some of the steam hammers the pistons are attached to the striking weight; in others, the cylinders are the moving parts.

Steam pile-hammers are of two types—single acting, in which the weight is raised by the steam pressure and allowed to drop by gravity; double acting, in which the steam pressure is used to accelerate the downward motion of the hammer and increase the force of the blow. Single-acting hammers are made heavier and of longer stroke than double-acting ones for the same service, and are slower in action. For heavy service, single-acting hammers usually have strokes of 36 to 42 inches and strike 50 to 70 blows per minute, while the double acting kind have strokes from 12 to 24 inches and strike 120 to 200 blows per minute. Lighter machines may work much faster.

The blows of the steam hammer are so rapidly given that the motion of the pile is practically continuous and under many conditions the effectiveness of the driving is thereby greatly increased. There are few data giving definite information concerning the relative costs of driving by drop-hammer or steam-hammer, but the steam-hammer has seemed to be gradually replacing the drop-hammer in important operations. It has as advantages that of causing less damage to the head of the pile; the driving may be accomplished at a more rapid rate, and more piles may usually be driven in the same time; the wear and tear upon the machine is much less than in the use of the drop-hammer, although the first cost of the steam-hammer is considerably greater.

*Water-jet pile drivers* are fitted with appliances for discharging a jet of water at the foot of the pile. The water comes up around the pile, bringing with it much of the material cut from beneath the pile and lessening the friction resisting its descent. The water-jet equipment is usually a straight piece of pipe, which may be held alongside the pile, with a nozzle at its lower end, the upper end being connected by a flexible hose to a pump which supplies water under pressure. The driver is equipped with leads and hammer, the latter being used to assist in sinking the pile by light blows and to settle it firmly into place after the jet is stopped.

The water jet is especially applicable to driving piles into sand, which usually offers considerable resistance to driving by the hammer alone. It may be used in any material which will be washed up by the jet and puddled about the pile, and frequently effects large savings

in placing it in position and to raise and lower the hammer in driving. The leads are supported in position by a triangular framework braced with backstays. The platform or deck to which the framework is attached also carries a hoisting engine with friction drums for handling the pile and hammer lines. The general arrangement is shown in Fig. 111. The details of arrangement and method of mounting vary widely according to the service for which the machine is intended.

Pile-drivers may be so mounted as to move forward, backward, and to the side by the use of rollers, or made to turn in any direction by mounting upon a turntable. For river work, they are usually rigidly connected to the deck of a barge which is moved to place the driver in position.

For railway work, drivers are commonly mounted upon cars, and many of them are very carefully designed to render efficient service under varying conditions. The cars are made self-propelling to make the machine independent of locomotive service, and leads which can be quickly raised and lowered are employed. The drivers are mounted upon turntables which permit driving upon either side, and the leads are arranged so that they may be turned to an inclined position for the purpose of driving batter piles. The stability of the machines when driving at the greatest reach from the cars is important and must be carefully considered in design. Combination machines, in which service as pile drivers is added to that as derricks or as excavators are also frequently employed.

A *drop-hammer*, as used in driving piles, usually consists of a solid casting, which is raised by means of a rope and allowed to drop upon the head of the pile. The hammer slides in guides upon the leads and should be so shaped as to give it a low center of gravity and a sufficient length to cause it to slide in the guides without rocking; it may be given a free fall by the use of nippers which engage a pin upon the hammer and are automatically disengaged at a certain height upon the leads. The more common method, however, is to raise and drop the hammer by the use of a hoisting drum with a friction clutch, the rope being permanently attached to the hammer—a more rapid system, which permits the operator to regulate readily the height of fall. The weight of hammer employed in ordinary work varies from about 2000 to 3500 pounds. For light work in small operations, light hammers may be used, while for heavy service and unusual conditions, heavier ones may be necessary. A heavy hammer with low fall is more effective in driving than a light hammer with high fall, as it may be operated more rapidly and causes less vibration in the machine.



A *steam pile-hammer* is one which is raised and dropped by a steam piston working in a cylinder attached to a frame which rests upon the head of the pile. The frame slides in the guides upon the leads, and the striking part or hammer is guided by the frame. In some of the steam hammers the pistons are attached to the striking weight; in others, the cylinders are the moving parts.

Steam pile-hammers are of two types—single acting, in which the weight is raised by the steam pressure and allowed to drop by gravity; double acting, in which the steam pressure is used to accelerate the downward motion of the hammer and increase the force of the blow. Single-acting hammers are made heavier and of longer stroke than double-acting ones for the same service, and are slower in action. For heavy service, single-acting hammers usually have strokes of 36 to 42 inches and strike 50 to 70 blows per minute, while the double acting kind have strokes from 12 to 24 inches and strike 120 to 200 blows per minute. Lighter machines may work much faster.

The blows of the steam hammer are so rapidly given that the motion of the pile is practically continuous and under many conditions the effectiveness of the driving is thereby greatly increased. There are few data giving definite information concerning the relative costs of driving by drop-hammer or steam-hammer, but the steam-hammer has seemed to be gradually replacing the drop-hammer in important operations. It has as advantages that of causing less damage to the head of the pile; the driving may be accomplished at a more rapid rate, and more piles may usually be driven in the same time; the wear and tear upon the machine is much less than in the use of the drop-hammer, although the first cost of the steam-hammer is considerably greater.

*Water-jet pile drivers* are fitted with appliances for discharging a jet of water at the foot of the pile. The water comes up around the pile, bringing with it much of the material cut from beneath the pile and lessening the friction resisting its descent. The water-jet equipment is usually a straight piece of pipe, which may be held alongside the pile, with a nozzle at its lower end, the upper end being connected by a flexible hose to a pump which supplies water under pressure. The driver is equipped with leads and hammer, the latter being used to assist in sinking the pile by light blows and to settle it firmly into place after the jet is stopped.

The water jet is especially applicable to driving piles into sand, which usually offers considerable resistance to driving by the hammer alone. It may be used in any material which will be washed up by the jet and puddled about the pile, and frequently effects large savings

in costs of driving. The pressure and volume of water required depend upon the kind of material to be penetrated. The pressure must be sufficient to cut the material and the volume enough to bring it up alongside the pile. Pressures of 75 to 150 lb./in.<sup>2</sup> and volumes from about 50 to 200 gallons per minute are common.

**194. Timber Piles.**—A timber pile is usually the lower portion of the trunk of a tree, from which the branches and bark have been removed. It is nearly circular in section and tapers from butt to tip. Many kinds of timber are employed for the purpose. The conifers—yellow pine, Douglas fir, spruce, and cedar—are commonly obtainable in straight pieces of considerable length. White and post-oak piles are not so straight, but are tough and hard and are suitable when requirements are severe. Cedar is valuable on account of its durability. For ordinary work in foundations, piles are usually required to be not less than 6 inches in diameter at the top, and commonly vary from 10 to 18 inches at the butt.

The specifications of the American Railway Engineering Association name the following requirements for timber piles:

#### RAILROAD HEART GRADE

1. This grade includes white, burr, and post oak; longleaf pine, Douglas fir, tamarack, Eastern white and red cedar, chestnut, Western cedar, redwood and cypress.

2. Piles shall be cut from sound trees; shall be close-grained and solid, free from defects, such as injurious ring shakes, large and unsound or loose knots, decay or other defects, which may materially impair their strength or durability. In Eastern red or white cedar a small amount of heart rot at the butt, which does not materially injure the strength of the pile, will be allowed.

3. Piles must be butt cut above the ground swell and have a uniform taper from butt to tip. Short bends will not be allowed. A line drawn from the center of the butt to the center of the tip shall lie within the body of the pile.

4. Unless otherwise allowed, piles must be cut when sap is down. Piles must be peeled soon after cutting. All knots shall be trimmed close to the body of the pile.

5. The minimum diameter at the tips of round piles shall be 9 inches for lengths not exceeding 30 feet; 8 inches over 30 feet but not exceeding 50 feet and 7 inches for lengths over 50 feet. The minimum diameter at one-quarter of the length from the butt shall be 12 inches and the maximum diameter at the butt 20 inches.

6. The minimum width of any side of the tip of a square pile shall be 9 inches for lengths not exceeding 30 feet; 8 inches for lengths over 30 but not exceeding 50 feet, and 7 inches for lengths over 50 feet. The minimum width of any side at one-quarter of the length from the butt shall be 12 inches.

7. Square piles shall show at least 80 per cent heart on each side at any cross-section of the stick, and all round piles shall show at least 10½ inches diameter of heart at the butt.

## RAILROAD FALSEWORK GRADE

8. This grade includes red and all other oaks not included in Railroad heart grade, sycamore, sweet, black and tupelo gum, maple, elm, hickory, Norway pine, or any sound timber that will stand driving.

9. The requirements for size of tip and butt, taper and lateral curvature are the same as for Railroad heart grade.

10. Unless otherwise specified piles need not be peeled.

11. No limits are specified as to the diameter or proportion of heart.

12. Piles which meet the requirements of Railroad heart grade except the proportion of heart specified will be classed as Railroad Falsework grade.

Piles are driven with the tips down, although in some instances it is desirable to drive the butts down. In certain soils, as quicksand, the upward pressure on the sides of the piles may force the pile upward after being driven with the tip down. Where piles are being driven through soft material to a hard substratum, it may be desirable to drive them with the butts down in order to obtain larger bearing surface at the base.

The butt of the pile is cut off accurately at a right angle to its length in order that the blow of the hammer may be uniformly distributed over the section. When the hammer strikes directly upon the head of the pile, it is common to use a hammer with a slightly concave upper surface. This tends to keep the pile centered in the leads, and minimizes the brooming effect of the blow. Heavy blows upon the head of a pile have a tendency to splinter and broom it, and a portion of the energy of the blow is used up in injury to the pile. When the brooming effect has become considerable, the efficiency of the driving is greatly decreased, and a large portion of the work is wasted. It has frequently been observed that when the broomed head of a pile has been cut off, an increase in the penetration under each blow is obtained, the penetration being in some cases more than doubled.

*Pile rings* are frequently placed upon the heads of piles to reduce the brooming effects. They are made of wrought iron from 2 to 4 inches wide and  $\frac{1}{2}$  to 1 inch thick; the pile is chamfered off so that the ring may be started on and be driven into place by the hammer. The rings are used repeatedly and serve for a larger number of piles.

*Pile caps* consisting of cast-iron blocks with tapered recesses above and below are used for the same purpose. The head of the pile is fitted into the lower recess and a hard-wood block into the upper one. The block is reinforced by a ring at the top and receives the blow of the hammer. The cap fits into the guides of the leads, and holds the head of the pile in place. After the pile is in place, the cap is drawn from its head by being attached to the hammer. Some steam



hammers are provided with anvils, which rest upon the head of the pile and receive the blow of the hammer.

In driving piles through hard material, it is often desirable to point the lower end, by cutting the end of the pile in the form of a pyramid, a blunt end 3 or 4 inches square being left at the bottom. A thinner point is apt to be too easily injured.

When piles are needed of greater length than those available, it becomes necessary to splice two piles together, which is accomplished by the use of fish plates. The ends of the two piles are cut square and butted together, the sides are trimmed flat for a considerable distance on each side of the splice and long wooden fish-plates are spiked to the sides, four or six fish-plates being commonly used.

**194. Bearing Power of Piles.**—There are so many variable factors affecting the supporting power of pile foundations that in most instances accurate determinations are not possible. Piles may derive their support either from a hard stratum at the bottom which resists the penetration of the foot of the pile, or from friction of the sides of the pile upon the material through which it is driven. Conditions may also vary widely as to the lateral support afforded the pile between the loaded end and the point of support.

*Piles Acting as Columns.*—When piles are driven through soft soil, offering slight resistance to lateral motion, and rest upon a hard substratum below, they may be considered as columns. They are fixed in position at the bottom with the top free to move laterally but held in vertical position by the caps joining them together. Piles driven in water and not braced depend for lateral stiffness upon being driven into the soil beneath to a sufficient depth to hold them firmly at the bottom. The length of the column in such a pile is to be taken from the cap to a point below the surface of the soil, a distance depending upon the firmness of the soil. In stiff soil a depth of 1 or 2 feet may be sufficient to firmly hold the pile. In less resistant soils, one-third to one-half the total penetration may be required.

When piles project into the air, they are braced laterally, so that no bending can take place and the strength of the pile is that of the compressive strength of the wood, or the resistance to penetration of the soil into which it is driven. The compressive resistance of wooden piles depends upon the kind of wood employed, but is taken at a low value, commonly about 600 lb./in.<sup>2</sup> When the pile acts as a column, this is reduced to  $600(1-L/60d)$ , in which  $L$  is the length of the column and  $d$  is the diameter at its middle point.

*Piles Supported by Friction.*—Numerous attempts have been made to state in a formula the relation between the penetration of a pile under a hammer blow of given energy and the load the pile may bear without yielding. The effective work done upon the pile by the hammer in striking the blow should equal the work done by the resistances in stopping penetration. There are, however, so many indeterminate losses of energy in the operation of striking the blow that a rational formula is not feasible—there is loss of energy in the friction of the hammer in the guides; some energy is consumed in brooming the head of the pile; the elastic compression of the pile consumes a part of the energy; the effectiveness of the blow is affected by the height of fall and velocity of the hammer. The impossibility of evaluating these and other data affecting the resulting penetration renders any formula obtained by discussion of the theory of the subject rather useless. Mr. Ernest P. Goodrich has made a very elaborate and interesting study<sup>1</sup> of the subject in which is produced a formula of very complicated form. This formula is reduced by evaluating experimentally many of the terms, but the result seems to show that a usable rational formula cannot be produced.

*Engineering News Formula.*—This formula was suggested in 1888 by Mr. A. M. Wellington, the editor of *Engineering News*. When the drop-hammer is used this formula is  $P = 2Wh/(s-1)$ , in which  $P$  is the safe load in pounds,  $W$  is the weight of the hammer,  $h$  is the height of fall in feet, and  $s$  the average penetration under the last blows in inches. When using a steam hammer the formula suggested by Mr. Wellington is  $P = 2Wh/(s-0.1)$ .

These formulas are the only ones in common use. They are empirical formulas obtained by studying all available data derived from tests of bearing power. It is assumed that the blows have been struck upon sound wood and commonly it may be necessary to cut off the head of the pile to remove the wood splintered or broomed by previous driving before making the tests. There must be no visible rebound of the hammer in striking the blows, and if such rebound occurs, it indicates that the fall is too great or the hammer too light, and the full effect of the blow is not communicated to the pile. The hammer must always be heavier than the pile, and should be twice as heavy, in order to strike an effective blow. The formulas are supposed to give a factor of safety of about six.

*Eytelwein's formula* is frequently used for reinforced concrete piles, on account of the greater weight of such piles. This formula

<sup>1</sup>Transactions, Am. Soc. C. E., Vol. XLVIII, p. 180.

takes into account the relative weights of pile and hammer. With a factor of safety of six the formula is

$$\text{Safe load} = \frac{2W_h H}{s(1 - W_p/W_h)}$$

in which  $W_h$  is the weight of hammer,  $W_p$  the weight of pile,  $H$  the height of fall and  $s$  the penetration.

It is desirable that the blows used for measuring penetration be struck with a hammer having free fall, as considerable loss of velocity may result from the resistance of a rope and friction drum. It is also necessary that the penetration under the last few blows be uniform and fairly represent the state of resistance of the pile. The penetration should not be less than one-half inch, as less penetration may indicate injury to the pile rather than resistance to penetration.

When piles are driven into soft or plastic materials, the resistance to penetration usually increases with time after the driving ceases. A rest of twenty-four hours may be sufficient to cause the material to settle against the surface of the pile so as to develop a resistance several times that existing when the material was disturbed by the operation of driving. Numerous instances are recorded in which it was found that the penetration under a blow had been decreased by a rest of a few days to from one-third to one-sixth of that at the end of the original driving. In case of driving into material of this kind, it is desirable to examine the effect of rest upon the bearing power and piles upon which tests are to be made should have a period of rest before the final test is made. Piles easily sunk by light blows or even by static pressure frequently carry loads a few days later much greater than those required to sink them. In coarse sand or gravel, the time effect is of less importance, if it exists at all.

Piles are frequently tested by applying static loads until movement occurs. Usually a load is balanced over a single pile, although sometimes a platform resting upon several piles is loaded. The pile is allowed to stand under the load at least twenty-four hours before being examined for settlement. It is desirable that the load be added in increments, each being allowed to stand for twenty-four hours, until a load is obtained which produces settlement.

In any test of bearing power, it is essential that the pile be tested under the same conditions that will afterward apply to the foundation. The determination of the requirements in any particular instance is largely a matter of judgment on the part of the engineer, but such judgment should be exercised with knowledge of all conditions that



may be evaluated and in accordance with the principles underlying such work.

*The spacing of piles* in a foundation is a matter of importance because of its possible bearing upon the supporting power of the individual piles. In general, piles should not be closer than 3 feet center to center, although they are sometimes driven  $2\frac{1}{2}$  feet apart. When piles are closely spaced over the area of a foundation, a considerable compression of the soil between them must result. The effect of this disturbance of the soil depends upon its character, but too close driving impairs the bearing capacity of all of the piles, and they cannot be considered as individually carrying loads up to their normal bearing capacity.

**196. Concrete Piles.**—Timber piles in structures intended to be permanent must be cut off below the water line, while concrete may be used without reference to moisture conditions. In many instances, therefore, the use of concrete piles is more satisfactory and economical than that of wood, sometimes effecting large savings in excavation. They may be made in any size considered desirable and are not subject to the limitations of wooden piles in this respect.

Concrete piles may be either molded in place or molded before placing and then driven like wooden piles. Those molded in place are generally not reinforced, while those to be driven after molding must be reinforced so as to resist the stresses brought upon them in handling and driving. The methods employed for molding piles in place are patented, and a number of forms of pre-molded piles are also patented.

*The Raymond pile* is made by driving into the ground a thin shell of sheet steel with a collapsible core which holds the shell to its form while driving. When the shell has been driven to the required penetration, the core is withdrawn and the shell filled with concrete. It is made tapering, usually 18 to 20 inches in diameter at the head and 6 to 8 inches at the foot, with a closed boot of heavier steel. They are made in sections for convenience in shipping.

The taper adopted for these piles gives high bearing capacity under ordinary conditions of use. The interior of the form may be inspected before placing the concrete. Difficulty is sometimes met in the collapsing of the thin shell when heavy hydrostatic pressure comes upon it, a fault sometimes corrected by driving a second shell inside the first one.

*The Simplex pile* is formed by driving into the ground a heavy steel pipe with the bottom closed by a special jaw. The pipe is driven to the depth required, and is then withdrawn as the hole is

filled with concrete. The jaw opens as the pipe is raised, permitting the concrete to pass through, and the concrete is rammed into place so as to fill completely the hole below the end of the pipe, and press the concrete against the earth at the sides of the hole. Sometimes a cast-iron shoe is used at the bottom of the pipe and is left in the hole when the pipe is withdrawn.

In driving through soft material which will not retain its form after the pipe is withdrawn, it is sometimes necessary to place a form of thin sheet metal inside the pipe and fill it with concrete before withdrawing the pipe. The soft soil then fills around this form and does not mix with or replace the concrete.

*The Pedestal pile* is intended to give larger bearing surface at the bottom of the pile. A pipe, or casing, is driven into the ground with a core inside which extends 3 or 4 feet below the bottom of the pipe. The core is then removed and the hole below the pipe is filled with concrete. The core is then rammed into this concrete, as shown in Fig. 112, so as to force the concrete into the earth at the sides of the hole and form an enlarged base upon which the pile may rest, which procedure is repeated until a sufficient volume of concrete has been forced into the base, the pipe being then withdrawn and the hole filled with concrete.

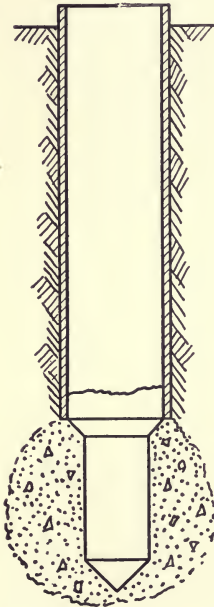

FIG. 112.

In *the Gow pile* a casing is sunk by use of a water-jet which removes the earth from inside the casing. A cutting tool is then used to widen the hole below the end of the pipe, the earth being removed by the water-jet. The hole is then pumped out and filled with concrete as the casing is removed.

Care is necessary, when using piles molded in place, that injury to the pile may not result from disturbance of the soil around the pile by driving other piles during the period of hardening—a danger which varies with the character of the soil. No pile should be driven near enough to be felt in the earth surrounding a green pile for a week after it is placed, unless the driving can be done before the initial set of the concrete takes place.

*Pre-molded piles* are reinforced like columns with lateral reinforcement of wire hoops, spiral wrappings, or wire mesh, combined with longitudinal steel bars, the cross-section most commonly employed

being octagonal or square with chamfered corners. The diameters in general use are from 12 to 20 inches for lengths of 20 to 50 feet, although larger and longer piles are sometimes employed and they are either of uniform section or given a slight taper, according to the service for which they are intended. When to be supported by friction upon their sides, tapering may be of value in increasing bearing power, but at somewhat increased cost of construction. Pointed shoes are used at the bottom to facilitate driving.

Piles are molded in either horizontal or vertical position. The molding is easier to handle and readily subject to inspection when in horizontal position. When molded in vertical position, the surface of concrete as deposited is normal to the length of pile, but special care is necessary in placing the concrete to eliminate voids. The reinforcement is connected up and handled as a unit in placing in the forms, to assure its proper position in the pile. During the early period of hardening, special attention should be given to keeping the concrete moist, and it is customary to allow it to harden about thirty days before it is driven, though in some instances the hardening has been hastened by subjecting the piles to a steam bath.

The steel reinforcement in a pre-molded pile must be sufficient to carry the stresses which occur during handling and driving as well as those caused by the loads which come upon it afterward. In raising the pile from a horizontal position or in moving it horizontally, the pile must be capable of carrying its own weight as a beam, supported near the ends or at the middle. Allowance for shocks and impact should be made. After driving, the pile may be in direct compression when supported laterally or it may act as a column when not so supported. The concrete used is ordinarily that known as 2000 pounds concrete of about 1 : 2 : 4 mixture, although sometimes a richer mixture is employed.

On account of the weight of concrete piles, heavy drivers are necessary. Steam hammers are found most effective and occasion less damage to the piles than drop hammers. Heavy drop hammers with low fall give better results than lighter ones with greater fall. Caps of various designs are employed to cushion the blow and prevent shattering the head of the pile. A wooden block receives the blow of the hammer, and layers of old belting, rope ends, or bags of sawdust have sometimes been used upon the head of the pile to prevent the shattering of the concrete. With proper precautions, it has been found practicable to drive pre-molded piles without injury where heavy driving was necessary.

When a jet is to be used in driving, a hole is cast through the



center of the pile into which the jet pipe may be inserted—a tapering core, or a collapsible form, being used for this purpose, which is cheaper than casting the jet pipe in the pile. Solid piles are also sometimes driven by use of the outside jet as with wooden piles.

There are several forms of patented pre-molded piles in use.

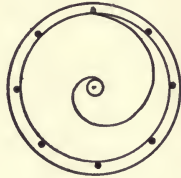

FIG. 113.

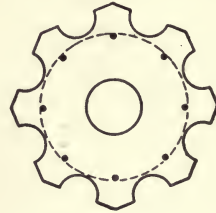

FIG. 114.

*The Chenoweth pile* is formed by spreading concrete over a wire mesh upon a platform, and rolling it over a mandrel, the longitudinal reinforcement being fastened to the wire mesh. Section for a Chenowith pile is shown in Fig. 113. *The Corrugated pile* is reinforced with electrically welded wire fabric, and is generally octagonal in cross-



FIG. 115.

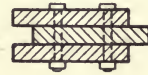

FIG. 116.—Wakefield Piles.

section, tapered, with grooves cut in each face. A section is shown in Fig. 114.

As the several types of concrete piles have been devised through the need of meeting differing conditions, each has advantages for certain kinds of service and is unsuited to certain other conditions. Careful determination of conditions must always precede choice of method of construction.

**196. Sheet Piling.**—Sheet piles are made to fit closely together and are driven in contact with each other so as to form a wall to prevent the lateral flow of soft materials, and find their greatest use in enclosing areas which are to be excavated, or guarding foundations against undermining by currents of water. They are made of timber, steel, or concrete.

The simplest and most common form of sheet pile consists of a

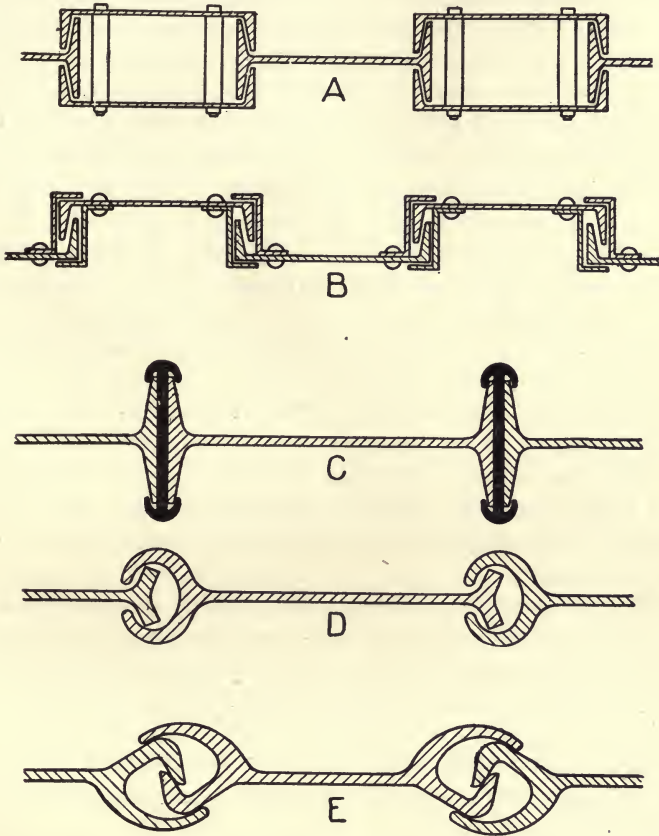

FIG. 117.

thick plank sharpened (as shown in Fig. 115) to a point at one side as so to cause each pile to drive closely against the one previously driven. When heavy timbers are employed, they are sometimes arranged with tongue and groove, which may be planed into the edges of the planks, or made by nailing strips to the edges. In some instances these are made to dovetail together.

*Wakefield sheet piling* is formed by bolting and spiking three planks together so as to form a tongue on one edge and a groove on the other, as shown in Fig. 116. The patent upon this pile has expired. They have been quite extensively used in this country and for heavy work are preferred to the other forms of wooden piles. They are made of planks from  $1\frac{1}{2}$  to 4 inches in thickness, depending upon the strength needed in the work, and are bolted together by pairs of  $\frac{1}{2}$ -inch or  $\frac{5}{8}$ -inch bolts, 6 or 8 feet apart, and spiked between the bolts. The planks are 12 inches wide and the tongue is made as wide as the thickness of plank, but not less than about  $2\frac{1}{2}$  inches for the thin planks.

*Steel Sheet-piling* is made in a number of forms either built up from standard rolled sections, or rolled in special sections so that the piles may interlock. A few of these forms are shown in Fig. 117. In form *A*, known as the Jackson pile, two channels bolted together with pipe separators are used alternately with I-beams. The Friestadt piling, *B*, consists of alternate channel bars interlocking with channels having Z-bars riveted to them. Form *C* is made up of I-beams held together by a special locking bar. Forms *D* and *E* are special rolled sections, the ends of which are designed to interlock, and may be used in work curved in plan.

For temporary work, where the piling is to be removed, steel sheet-piling is largely used and is often more economical than timber piling. The interlocking edges hold the piles together in driving, and give a certain amount of transverse strength to the wall. In hard driving, the steel piling is less injured than timber piling and it may be repeatedly used.

*Reinforced concrete sheet-piles*, shaped like wooden piles, either rectangular or with tongue and groove on the edges, are often used on important work where the piling is to be left permanently in the structure, and are often reinforced with longitudinal bars to resist the stresses occurring in handling and driving. The loads coming upon them after driving are in a transverse direction and the piles should be designed for hydrostatic pressure, being supported laterally by the waling.

Concrete sheet-piling is sometimes made interlocking by setting interlocking steel bars in the pile edges, the interlocking parts being then enclosed in concrete after driving. In some instances semi-circular grooves are left in the edges of the pile, the circular opening between the piles being filled with concrete after driving.

In driving sheet-piling it is necessary to first drive a row of guide piles to which may be attached horizontal timbers, or wales, against which the sheet piling may be driven. The driving of ordinary sheet-



piles is much lighter work than driving bearing piles, and light steam hammers are used for the purpose. These are frequently operated from a derrick without leads and may be handled with greater rapidity and less injury to the piles than the ordinary heavy driver.

#### ART. 55. COFFERDAMS

**197. Types of Cofferdams.**—A cofferdam is a structure intended to exclude water and soft materials from an inclosed area, in order to permit the water to be pumped out and the work of placing a foundation to be done in the open air. This method is applicable only to rather shallow foundations, and for depths greater than about 30 feet other methods are more economical. Cofferdams can be used only where the soil at the bottom is fairly impervious, so that an excessive flow of water under the dam does not occur.

The type of structure for this purpose varies with the depth of the foundation and the character of the soil upon which it is to be built. Earth, sheet piling, timber cribs, or combinations of these arranged to meet special conditions, are the materials employed.

*Earth cofferdams* are banks of earth surrounding the area of the foundation, and are made thick enough to sustain the pressure of the water and to prevent excessive leakage into the inclosed space. The use of plain earth dams for this purpose is limited to shallow water without currents; where danger of washing from a light current exists, a wall of bags filled with clay and gravel or a revetment of such bags upon the exposed face of the embankment may be employed. The top of the dam should be at least 2 feet above the water surface, and the top width not less than 3 feet. A row of sheet piling is sometimes driven and inclosed in an earth dam for the purpose of reducing the size of embankment needed, or of cutting off a flow of water through the soil under the dam.

*Sheet-pile cofferdams* are constructed either of timber or steel piles in single or double rows, and are supported by guide piles, timber frames, or cribs. Where a double row of sheet piling is used, a filling of earth between the rows is necessary.

A *crib cofferdam* consists of a timber crib built so as to be watertight and is floated into place and sunk around the site of the foundation.

*Movable cofferdams* which may be removed after using and sunk again have been employed in a number of instances. These may be cribs with watertight compartments, or framework supporting sheet piling.

**198. Sheet-Pile Cofferdams.**—When timber sheet-piling is used the most common form of cofferdam consists of two rows of piles with a filling of puddled earth between them—a system of construction shown in Fig. 118. Two rows of guide piles are first driven.

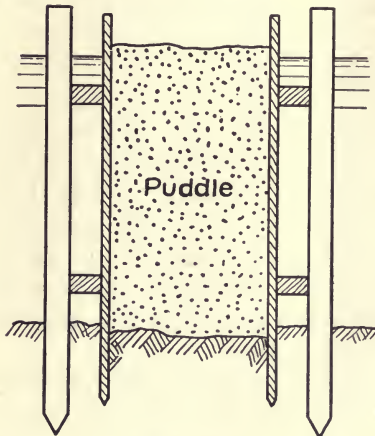

FIG. 118.

Horizontal timbers known as walls are attached to these, and the sheet-piling driven inside against the wales, the tops of the guide piles being tied together to prevent spreading when the puddle is put in. The guide piles should be driven to a firm bearing in order to develop the transverse strength of the pile in resisting the water pressure. Horizontal braces across the area to be drained may sometimes be used to assist the cofferdam against

lateral pressure, and when this is not feasible, the width of cofferdam must be made sufficient to provide lateral strength.

The sheet-piling must be driven into a fairly impervious stratum to prevent leakage under the dam, and pervious material overlying such stratum between the rows should be excavated sufficiently to give the puddle contact with the impervious material below. The

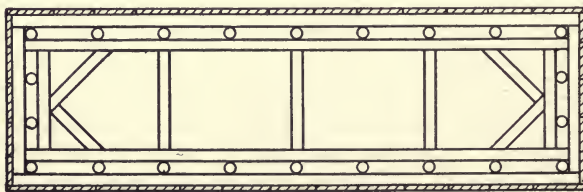

FIG. 119.

puddle needs to be both impervious and stable, and a mixture of gravel and clay is desirable for the purpose. Clay is impervious but washes easily if the water finds an opening through it, while gravel or coarse sand mixed with the clay tends to prevent such washing. The thickness of puddle required depends upon its quality and upon the pressure to be resisted, a thickness of one-fourth to one-sixth of the depth being usually sufficient. For best results, the puddle should be placed in thin layers and well tamped in damp condition.

A single wall of sheet-piling is often used supported by guide piles or by an interior framework—a method which requires less space than the puddle wall type and is preferable where it is important not to restrict the water way. Plan of a cofferdam of this type for use in constructing a bridge pier is shown in Fig. 119. The guide piles are first driven, wales attached, and the sheet-piles driven against the outside waling. Braces from wall to wall across the opening are used to assist in resisting the lateral pressure. Such bracing when needed may be placed at lower levels as the water is pumped out and excavation proceeds.

When guide piles cannot be driven to firm bearing, timber frames are sometimes used to act as guides and support the sheet-piling against lateral pressure. These frames may be built upon the ground, floated to the site and sunk into position. The sheet-piles are then driven around the frames so as to inclose it.

Interlocking steel piling is often employed for single wall work because of its greater strength and tightness. Timber piling for such use should be tongued and grooved. Wakefield piling has most frequently been used.

Some leakage is always to be expected in cofferdams, and in many instances special precautions are necessary to exclude water. The possibility of meeting difficulty in preventing leakage is the principal objection to this method of construction. Banking clay against the outside of the cofferdam is a common expedient to prevent leakage through or immediately under the dam. When it is feared that channels may open under the piling, gravel may be deposited around the base of the dam to close such incipient openings. Tarpaulins are often employed to cover the outside of the dam, or spread out upon the bottom outside the base of the dam and weighted with gravel. When the bottom is rock, it is sometimes necessary to cover the whole area inside the cofferdam with a layer of concrete to prevent inflow of water through seams in the rock.

**199. Crib Cofferdams.**—Timber cribs built on land and floated into position are frequently used as cofferdams, and for shallow depths, these may be made of a framework of timber with a covering of planks upon the outside. Usually the crib is formed of two walls made of squared timbers laid on top of each other, tied together, and braced with framework, and is sunk by loading with gravel or earth, and sometimes filled with puddle to increase its watertightness. The crib itself may be made practically water-tight, so that leakage is restricted to the space below the crib. In using this method there are no braces across the space in which the foundation is to be placed.



The bottom should be leveled before sinking the crib, or when on bed rock, the bottom of the crib may be made approximately to fit the surface of the rock. Sheet piling may be driven around the outside of the crib to prevent leakage under the crib when the crib does not lie upon the rock. Tarpaulins fastened to the crib near the bottom are frequently used to prevent leakage under the crib. A deposit of puddle around the base of the crib is generally sufficient to seal the bottom against excessive leakage in ordinary work, but a layer of concrete over the rock bottom is sometimes necessary.

Cribs are sometimes made so that they may be removed and repeatedly used. These have sometimes been used for bridge piers, being made in two parts joining together on the short sides so that they may be taken from around the foundation after it is constructed. Watertight compartments are provided which may be pumped out when it is desired to float the cribs. Sometimes sheet-piling is used around these cribs, which may be withdrawn before raising them.

#### ART. 56. BOX AND OPEN CAISSONS

**200. Box Caissons.**—A caisson is a watertight casing within which the work of placing a foundation may be done. The casing forms a shell which contains and usually remains a permanent part of the foundation. Caissons are of three general types: Those closed at bottom, known as *box or erect caissons*; those open at both top and bottom, known as *open caissons*; and those closed at top, called *pneumatic or inverted caissons*.

Box caissons of timber are commonly employed when masonry foundations are to be placed upon piles cut off under water. These caissons are water-tight boxes, open at the top, which may be floated into position over the piles upon which they are to rest and then sunk by building the masonry inside them. The floor and lower part of the caisson is usually a permanent part of the foundation, but the sides which extend above the water are intended to act as cofferdams during construction of the masonry and are removed upon completion of the work.

The construction of box caissons varies with the depth of water in which they are to be sunk and the shape and dimensions of the foundations. For light work, timber studding with plank sides and bottom may be sufficient, while in heavier work, a bottom of two or more thicknesses of 12×12 inch timbers, with sides built up of similar timbers on top of each other, and drift-bolted together, or timber framework with vertical staves may be used. The bottom

must be capable of carrying the load of masonry required for sinking and the sides must resist the water pressure or the outward pressure of material with which it may be filled. The caisson may be built on land, launched and floated to the site of the foundation, or when heavy timbers are to be used for a floor, it may more easily be built afloat.

Timber box caissons are occasionally used as a base for foundations upon fairly firm soil. The excavation must be made to the depth required before the caisson is sunk. Such caissons were used in the foundations of the south pier of the Duluth Ship canal. "They<sup>1</sup> were from 24 to 36 feet wide, 21 feet high, and from 50 to 100 feet long. The floor was 8 inches thick laid close, the channel side had a solid wall of a double thickness of 12×12 inch timbers, while the opposite side was composed of a single thickness of 12×12 inch timbers laid close. Connecting and bracing the two walls were transverse bulkheads of 10×12 inch material spaced 4 feet center to center horizontally.

"The caissons were built in the harbor, towed to the site, and sunk by filling with rock and gravel. After sinking, the caissons were covered with a layer of heavy timbers, in which was built the concrete pier, the top of the caisson being slightly below low water level."

For work of this kind, a timber crib or grillage which is not watertight is sometimes used for the lower part of the foundation, the top of the crib being below low water. A box caisson is then sunk on top of the crib. The floor of the caisson carries the masonry superstructure, and the sides, which are intended only to exclude water during construction, are removed when no longer needed. Reinforced-concrete box caissons have been used in some instances. They may be made part of the permanent structure above as well as below the low water level, and do not need the cofferdam sides.

Box caissons of small size have sometimes been sunk several feet into soft material by the use of water jets under the bottom. A number of pipes are run through the bottom to carry the water, which washes the material from underneath and allows the caisson to sink.

**201. Types of Open Caissons.**—An open caisson consists of a casing, with one or more openings extending through from top to bottom, intended to be sunk through soft materials which may be displaced by the weight of the caisson or removed by dredging through the openings. The caisson is always an integral part of the foundation. It may be simply a shell to contain concrete upon

<sup>1</sup> Jacoby and Davis, *Foundations of Bridges and Buildings*, p. 243.



which the main reliance for strength is placed, or the caisson itself may be designed to bear the loads coming upon the foundation and the filling for the purpose of sinking and anchoring it.

The open-caisson method is extensively used and has been employed in placing foundations when the depth is too great for any of the other methods in common use. The caissons may be made of timber, steel, or concrete, and vary widely in design, according to the size and character of the foundation to be constructed. Three types of open caissons are in use: (1) Single-wall caissons of timber, consisting of an outer watertight wall with the bracing necessary to enable it to hold its form; (2) cylinder caissons, consisting of a single or double cylindrical shell of steel or concrete with a single opening at the center; (3) caissons having several openings or wells, with double walls between and around them. The double walls are joined at bottom into cutting edges, and the spaces between them filled with concrete or other materials to aid in sinking.

Caissons of the first type are used where the depth of sinking is small or the material through which they are to be sunk is soft. They are frequently employed for piers where the foundation is upon rock with little or no soil above it, and a shell is needed within which the concrete body of the pier may be formed. Cylinder caissons are used for foundations of small area which must be sunk to considerable depths through soft materials. The method with several openings is used for larger foundations requiring sinking to considerable depths.

**203. Single-wall Timber Caissons.**—Single-wall caissons are constructed in the same manner as box caissons, without the bottoms. The walls are commonly built up with 12×12 inch timbers or with 12 inch plank laid flat. They are sunk upon a bottom of rock or other firm material which has been prepared to receive them. It is then only necessary to provide an outer wall of the form desired for the foundation, with bracing to resist the water pressure when pumped out, and a means of carrying sufficient load to sink it.

When the site is covered with soft material, sinking is accomplished by weighting the top of the caisson with some material which may afterward be removed, by dredging the soil from inside the bottom, and sometimes by using a water-jet to wash the soil from under the walls. After sinking, the bottom is sealed with concrete deposited under water and the caisson pumped out, after which the concrete filling may be placed in the open air. In some instances the filling is all placed through the water without pumping out the caisson, in



which case, it would not be necessary that the caisson be water-tight, but it must be capable of holding the concrete filling.

The permanent portion of a timber caisson usually terminates below low water, the part extending above the water being removed after serving as a cofferdam within which the masonry has been constructed.

In constructing the Columbia River Bridge of the North Coast Railway,<sup>1</sup> open caissons were used to provide forms for the construction of concrete piers upon the hard bottom of the river. The depth of water was about 30 feet and velocity of current seven miles per hour. The construction of the caissons is shown in Fig. 120.

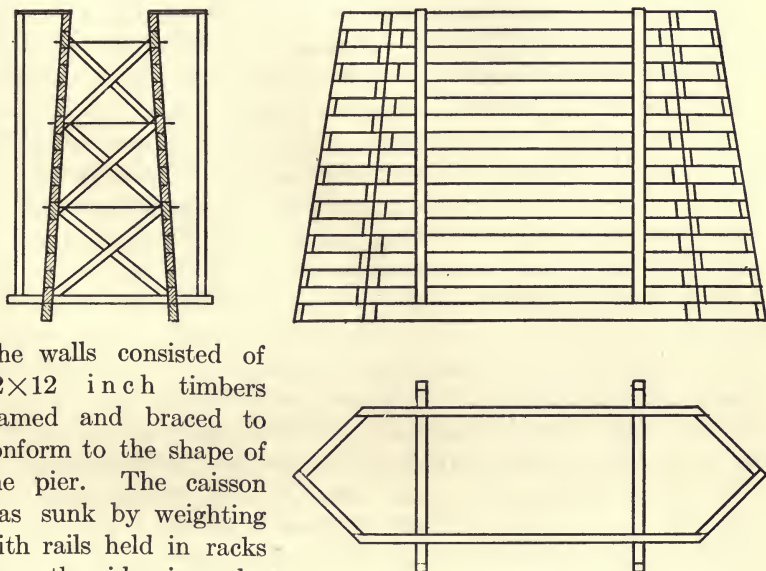

The walls consisted of 12×12 inch timbers framed and braced to conform to the shape of the pier. The caisson was sunk by weighting with rails held in racks upon the sides in order to keep the load near the

bottom and prevent capsizing. The concrete was deposited through the water to the depth of 32 feet, large buckets with movable bottoms being used for the purpose.

In the construction of a pivot pier on rock foundation, the Engineering Department of Boston used a single-wall circular caisson 60 feet in diameter and 30 feet high as a form for the concrete body of the pier. The caisson was built of about 145 courses of 3×12 inch yellow pine planks, 8 feet long, laid flat and breaking joints. The ends were beveled to make radial joints, and each plank secured to

FIG. 120.

<sup>1</sup> Engineering News, Oct. 5, 1911, p. 392.

those below it by 1-inch oak tree nails 9 inches long, two at each end of each plank. In addition, the planks were well spiked to the lower courses throughout their lengths with 6-inch spikes. The courses were also secured together by 4×12 inch vertical planks opposite alternate joints.

Before placing the caisson, the site was dredged to rock. "There<sup>1</sup> was no attempt to construct the crib so that on the bottom it should conform to the variations in the rock surface. Instead, the bottom of the crib was made level and it was sunk until it took bearing on only a portion of the lower edge at the highest rock level. Then to provide continuous bearing to all parts of the circumference, and especially to complete the inclosure of the crib and confine the concrete that was afterward deposited within it, wooden boxes of varying sizes, but averaging about 4 feet square and 4 feet deep, were filled with lean concrete, lowered to the bottom and placed by divers under the edge of the crib to form a continuous wall. After the concrete boxes were placed, the excavation outside the crib was back-filled with gravel until the whole crib was surrounded by filling to about 29 feet below low water or some 2 feet above the bottom courses of plank. This backfilling formed an effectual seal to retain the concrete which was deposited in water inside the crib without unwatering the crib."

**203. Cylinder Caissons.**—The method of sinking wells by using a curbing of brick masonry which sinks as the earth is excavated from the bottom has been in common use for many years. A wooden cutting edge is constructed and the brickwork started on top of this and built up as the sinking progresses. This method has been used for a long time in India for bridge foundations and in a number of instances in Europe. Usually work of this character has been of small diameter and sunk to comparatively shallow depths, but in some instances large shafts have been sunk by this method, and depths of over 200 feet have been reached.

Circular caissons of metal and reinforced concrete have come into use more recently and are frequently employed where foundations of small area are feasible, and in a few instances for foundations of larger area where circular piers are to be constructed. They are frequently used for the foundations of highway bridges where considerable depths must be reached, a pair of cylinders braced together being employed for each pier. Circular caissons of small diameter are constructed with single walls and a cutting edge at the bottom, those of larger diameters having double walls with space between the walls for loading with concrete.

<sup>1</sup> Engineering Record, Aug. 2, 1913.

*Steel walls* are commonly used for circular caissons in this country, although small sections are frequently of cast-iron pipe resting upon a steel cutting edge. In the foundations of the California City Point Coal Pier, 4-foot cast-iron pipe was used in lengths of 12 feet bolted together.<sup>1</sup> A conical steel section 8 feet in diameter was used at the bottom to give large bearing area, and the concrete filling in the pipe was reinforced with vertical steel.

In constructing foundations for torpedo boat berths at Charleston, S. C., steel cylinders 8 feet in diameter and 42 to 52 feet long were used as cofferdams.<sup>2</sup> The cylinders were sunk through a bed of sand and about 4 feet into a bed of blue clay, which sealed the bottom, the soil inside being then excavated to near the bottom. Some wooden piles 45 feet long were driven inside the cylinder and the bottom section 5 feet deep filled with concrete, inclosing the tops of the piles. A form was then set up inside the cylinder and 4-foot reinforced concrete columns constructed to the top, the forms and cylinder above the bottom section being then removed.

Cylinders 8 feet in diameter were used for the foundations of the bridge over the Atchafalaya at Morgan City, La. (see Baker's *Masonry Construction*). These were sunk to a depth of 120 feet below high water and from 70 to 115 feet below the mud line. Below the river bottom, the cylinders were of cast iron  $1\frac{1}{4}$  inches thick and above of wrought iron  $\frac{3}{8}$  inch thick.

A double-wall caisson of steel was used for the pivot pier of the Omaha Bridge and Terminal Company's bridge across the Missouri River at Council Bluffs, Iowa.<sup>3</sup> The caisson was of steel, 40 feet outside and 20 feet inside diameter and was sunk through sand and clay and coarse sand to the rock 120 feet below low water. The spaces between the walls were filled with concrete to furnish weight for sinking. In sinking, the material was dredged from inside the caisson, and water jets were used upon the outside to reduce the friction. Twenty 3-inch vertical pipes were carried down inside the outer cylinder to the cutting edge to provide for operation of water jets.

*Reinforced concrete walls* are gradually coming into use for cylinder caissons and seem to offer advantages for the purpose. The weight of concrete is of help in sinking and obviates the necessity of so much temporary loading, which is an item of considerable expense, while the greater durability of the concrete as compared with steel is also

<sup>1</sup> Engineering News, June 27, 1908.

<sup>2</sup> Engineering News, Nov. 11, 1915.

<sup>3</sup> Engineering Record, Jan. 24, 1903.



of value. Gravel filling may sometimes be employed in a reinforced concrete cylinder, while the steel cylinder should be filled with concrete.

Concrete cylinders are cast in place by using adjustable forms for building up the upper end as the cylinder is sunk. In some instances, however, they are cast in sections off the work and placed in position after hardening.

Reinforced concrete cylinder caissons were used in the foundations of the lumber docks at Balboa, Canal Zone.<sup>1</sup> The caissons were made 8 feet in outside and 6 feet in inside diameter and were pre-cast in sections 6 feet long. The bottom sections had conical exterior surfaces, widening to 10 feet in diameter

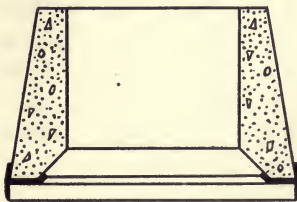

FIG. 121.

and fitted into a cutting edge made of steel plates as shown in Fig. 121. The sections were reinforced with vertical bars and horizontal rings of steel, and were fastened together by means of six 1-inch anchor bars 12 feet long, which pass through cores molded in the shell. The rods were fastened together by the

use of sleeve nuts which were adjusted in niches molded in the shell for the purpose.

The caissons were sunk 60 to 70 feet to rock, by laborers excavating inside of them, the water being kept down by pumping. The cutting edge was embedded about a foot in the rock, and a conical depression was blasted out of the rock in the center to give the concrete filling a strong bond.

Caissons having shells  $6\frac{1}{2}$  feet in outside and  $4\frac{1}{2}$  feet in inside diameter were used in the foundations for the Penhorn Creek Viaduct of the Erie Railroad.<sup>2</sup> They were reinforced with  $\frac{1}{2}$ -inch horizontal rings spaced 6 inches apart. The caissons were built in place in sheeted pits, 12 feet square and 15 feet deep, collapsible steel forms 5 feet long being used and 29 feet of caisson built at one operation, which after being allowed to set was sunk and another section added, depths of about 70 feet being reached in this way. The concrete was allowed to harden six days before sinking, which was accomplished by dredging with an orange peel bucket, and sometimes using a water jet. The jets were usually necessary below depths of about 40 feet. Four  $1\frac{1}{2}$ -inch pipes suspended from the derricks and guided by hand were employed. The jets were used around the upper part

<sup>1</sup> Engineering Record, July 20, 1912.

<sup>2</sup> Engineering News, Oct. 13, 1910.

of the exterior faces of the caissons to within about 20 feet of the bottom.

Concrete cylinder caissons 6 feet in outside diameter, 8 inches thick and from 33 to 55 feet deep were used in the foundations for the storehouse of the Boston Army Supply Base; 577 of these piers were placed in 110 working days.<sup>1</sup> Pits 12 feet deep and 10 feet 4 inches square were dug and concrete cylinders 22 feet high constructed in the pits. The caissons were sunk below the bottoms of the pits by men digging the earth from inside them and forcing them down by the use of jacks. The forms were removed and excavation begun twenty-four hours after pouring the concrete. When a sufficient depth could not be reached by this method, the concrete cylinder was continued at the bottom in open cut behind poling boards. After the concrete shell reached solid clay, the hole was belled out below the end of the shell to give a larger bearing to the base of the pier and the whole filled with concrete. Ground water was kept down by constant pumping.

**204. Dredging through Wells.**—When foundations are to be sunk to considerable depths through soft materials, the method of dredging through wells is very commonly employed, wherein, caissons of wood, steel, or concrete are built with vertical openings, or wells, extending through them. The body of the caisson surrounding the wells is filled with concrete to provide weight for sinking, and the soil at the bottom is removed by dredging through the wells, or by men in open excavation when the water can be kept down by pumping.

When the foundation is to be sunk through deep water, the caissons may be built on land or on barges and floated to the site. When the site for the foundation is on land or in shallow water, the caisson may be started in place, in an open cut or inside of cofferdams, and built up as the sinking proceeds. As the position of the caisson cannot be accurately controlled in sinking, it is necessary to make the horizontal area covered by it larger than that of the foundation it is to carry. In a large caisson, the descent is guided by the manner of excavation, when resistance is met upon one end which tends to tip the caisson, the excavation is confined to that end until it is righted. If the caisson is narrow and the wells in one line, the control in a transverse direction is often difficult. Obstructions, such as boulders or sunken logs under the cutting edges, offer the most serious obstacles to work of this kind. These are not met at great depths and are commonly removed by divers, or sometimes by the use of a water jet.

<sup>1</sup> Engineering News-Record, Sept. 24, 1918.

Timber caissons have been employed more frequently than metal ones in this country.

The first use of deep open caissons in America was in the construction of the foundations of the Poughkeepsie bridge over the Hudson River.<sup>1</sup> The largest of these caissons was 60×100 feet in plan for the bottom 40 feet, narrowing to 40 feet in width at the top. There were 14 wells, each 10×12 feet, separated by one longitudinal and six transverse walls. The cutting edges at the bottom were 12×12 inch white-oak timbers, and the walls were of hemlock, solid and triangular in shape for the lower 20 feet, widening at that height to their full widths. The end walls and longitudinal walls were hollow above this height. The six transverse walls were solid and 2 feet thick for the full height.

The hollow walls were filled with gravel in sinking the crib and the soil was excavated through the wells with a clam-shell bucket. The caisson was 104 feet high and was sunk until the top was 23 feet below low water, the last dredging being done with the top submerged. The wells were then filled with concrete, and a box caisson with bottom of grillage 6 feet thick was sunk on top and the masonry of the pier built up in this as a cofferdam, the sides being removed when the masonry was above water.

Open timber caissons were used in the foundations of the bridge of the Oregon Railway and Navigation Company across the Willamette River at Portland, Oregon.<sup>2</sup> They were 36×72 feet with six well holes, each 9 feet square, the cutting edges being made of steel plates inclosing the bottom timbers, with 6×6× $\frac{3}{4}$ -inch angles at the bottom. The lower 11 feet of the crib was of solid timber, triangular in shape, with vertices at the cutting edges. Above that height, walls 12 inches thick were carried up and the entire spaces around the wells filled with concrete as the caissons were sunk. The caissons rest upon cemented gravel 120 and 130 feet below low water, and when in final position the wells were filled with concrete. The crib proper ends at 20 feet below low water and the upper part of the caissons were built to be used as cofferdams within which the superstructure of the pier could be constructed.

“In the construction of each of these piers a substantial dock was first constructed in the river, consisting of about 100 piles well driven down, capped, and braced together. Borings were then made around the entire perimeter of the crib at spaces about 8 feet apart, and the elevations of hard material at all points were determined. It was

<sup>1</sup> Transactions, American Society of Civil Engineers, June, 1888.

<sup>2</sup> Railway Age-Gazette, July 14, 1911.



found to be on a considerable slope, showing a difference of elevation of 22 feet for opposite diagonal corners. When these elevations were determined, pipes were successively sunk at numerous points around the perimeter and in the location of the cross walls, and holes drilled in the hard material to a common level some 2 feet below the lowest elevation of the top of the cemented gravel. As soon as the drilling at each hole had been completed to the proper elevation, a cartridge of black powder and dynamite in a sheet iron case was lowered to the bottom of the hole and discharged by an electric battery. This process was repeated at such frequent intervals as it was deemed would produce a bottom uniform in character throughout the entire area of the crib. Thus the blasting for leveling the cemented gravel was carried on before an excavation was made through 50 feet of gravel and sand. In the meantime the steel cutting edge had been set up and riveted together on ways in a shipyard convenient, and enough timber put on to float the crib, which in this condition was some 30 feet high. It was then floated into position in the dock already prepared and other piles driven on the open end of the dock, entirely inclosing the crib."

*Iron and steel caissons* have been extensively used by English engineers, but in this country the use of metal has usually been restricted to the cylindrical form, as timber has generally been found cheaper and more satisfactory.

The foundations of the Hawkesbury bridge in Australia is a notable example of this method. The caissons were of wrought iron, 48 feet long and 20 feet wide, with semicircular ends. Three circular dredging wells were used, 8 feet in diameter and 14 feet between centers. The pockets around and between the wells were filled with concrete to aid in sinking the caisson, and the sides and filling were continually built up as the sinking progressed. The caissons were bedded upon sand, the maximum depth reached being 162 feet below high water, through 108 feet of mud and silt.

The bottoms of the caissons were made flaring for the lower 20 feet, making the bottom 2 feet wider all around, this arrangement being intended to reduce friction on the sides, but it was found to increase seriously the difficulty of guiding the caisson. When the soil is not uniform over the base, there is a tendency to travel toward the firmer material, which was obviated by making the surfaces of the wider bottom sections vertical instead of flaring, with an offset about 20 feet above the cutting edge.

*Concrete open caissons* are rapidly coming into use and possess many advantages where they may be built in place and started in the

open air. When the wells are filled with concrete, it makes a monolithic structure, with no parts subject to decay or corrosion, and when heavy walls are used, the weight is of advantage in sinking. Reinforcement is usually employed, although in a few instances heavy shells have been sunk without reinforcement. Light reinforcement seems desirable in nearly all cases as having additional security against cracking.

The method of dredging through wells was used in sinking concrete caissons for the foundations of the Pittsburgh & Lake Erie Railroad bridge at Beaver, Pa. The caissons were 80 feet long and 28 feet wide with semicircular ends. The shell was 7 feet thick with two

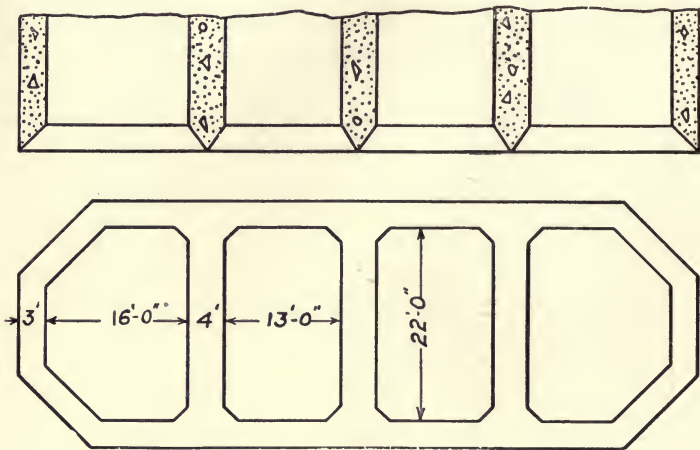

FIG. 122.—Concrete Caisson.

cross-walls each 5 feet thick, and was tapered in the lower 9 feet to the cutting edge of steel. Rectangular cofferdams were constructed around the site in about 7 feet of water and pumped out. The caissons were then built inside the cofferdams and sunk through about 38 feet of sand and gravel to the rock. When they had been sunk nearly to the rock by dredging through the open walls, they were transformed into pneumatic caissons and bedded upon the rock by the pneumatic process.

Fig. 122 shows a reinforced-concrete caisson used in the foundation of a pier of the American River bridge of the Southern Pacific Railroad.<sup>1</sup> It was 76 feet long, 28 feet wide, and 22 feet high, with a shell 3 feet thick and three cross-walls each 4 feet thick, and was built when the stream was dry in a pit dug to the level of ground water, being

<sup>1</sup> Engineering Record, August 27, 1910.

sunk by dredging through the four wells. When the top of the caisson reached the ground level, a timber cofferdam was constructed on top. The sinking was then continued until the stratum of cobbles and boulders upon which it was to rest was reached. The wells were then filled with concrete and the pier built up in the cofferdam. This caisson was very light in weight and the sinking so slow that it was found more economical to construct the other piers by excavating inside of sheet iron cofferdams.

In constructing the channel pier of the North Side Point bridge over Allegheny River at Pittsburgh, a concrete caisson  $83\frac{1}{2} \times 23$  feet was used, with 4 wells  $10 \times 9$  feet spaced 19 feet between centers.<sup>1</sup> When the caisson reached a height of 31 feet, with the cutting edge 17 feet below the bed of the river, a transverse crack extending from top of caisson to below the river bed occurred near the mid length, probably due to tension in the top of the caisson caused by unequal dredging. This caisson was unreinforced. It was blasted out and replaced by one reinforced by longitudinal bars.

#### ART. 57. PNEUMATIC CAISSONS

**205. The Compressed-air Method.**—A pneumatic caisson as ordinarily employed consists essentially of an air-tight box, or working chamber, open at the bottom, which may be filled with compressed air to keep back the water and permit the excavation of the soil from below the bottom of the caisson by men working in the compressed air. The working chamber is ordinarily at the bottom of a crib, constructed in a manner similar to an open caisson and arranged to be filled with concrete to aid in sinking. Shafts with air locks connect the working chamber with the outside air, and provide means of entering the working chamber and transporting materials to and from it.

This method is frequently employed for foundations to depths within which men may safely work in the compressed air, about 110 feet below water surface, and is sometimes combined with the open-caisson method, being used where obstructions may be met in sinking the open caisson, or for bedding a caisson which has been sunk by open dredging. The caissons are constructed of timber, metal, or concrete. The use of timber caissons has been quite common in the United States, although concrete seems to be coming into more general use, while in Europe, iron and steel are preferred.

The pneumatic system was first applied to large foundations in

<sup>1</sup> Engineering News, Oct. 17, 1912.



this country by Mr. Eads in the construction of the St. Louis arch bridge over the Mississippi in 1870, where a depth of 109 feet below water surface was reached. This was followed by the Brooklyn bridge foundations, in which the caissons were very large in plan and sunk to a depth of 78 feet. Since that time, pneumatic caissons have been used in a large number of structures, with rapid improvement in the methods of handling the work, and in preventing injurious effects upon men working in the compressed air.

Pneumatic caissons have been quite extensively used for heavy building foundations, particularly in New York City, where it has been found necessary to carry the foundations of high buildings through unstable materials to solid rock, without undermining older buildings on more shallow foundations. In such construction, separate caissons of small area are sunk for individual piers, although frequently two or more piers rest upon a single caisson. The layout of a foundation for a heavy building is a matter requiring very careful study. The first instance in which this method was applied to a building in New York was in the Manhattan Life Insurance Company's building by Kimball & Thompson, architects, in 1893.<sup>1</sup> Since that time the use of pneumatic caissons has become quite common.

**206. Construction of Caissons.**—The materials and methods of construction of a caisson usually vary with its size and shape. Cylinder caissons are generally of steel, although concrete is now being used to considerable extent. The thickness required for the concrete walls usually prevent its use for cylinders less than about 8 feet in diameter. Large caissons of rectangular shape are frequently made of timber, although steel is sometimes used, while the use of concrete is increasing rapidly.

The working chamber is surrounded by sloping sides, resting upon the cutting edges and widening to give support to the roof, which must be capable of carrying the load of filling used in sinking the caisson. In large caissons it is necessary to brace the side walls, bulkheads being sometimes built both transversely and longitudinally across the working chamber for the purpose. In some of the older caissons, when the masonry of the pier was built upon the roof of the working chamber, the roofs were made very thick. The roof of the large caisson for the Brooklyn bridge was 22 feet thick of solid timber; that of the Havre de Grace bridge was 8 feet thick. In others, heavy bulkheads were used to support thinner roofs.

In timber caissons, in addition to the walls of solid timber, plank

<sup>1</sup> Engineering Record, Jan. 20, 1893.

sheeting is used on both inside and outside surfaces, being caulked carefully to make them air- and water-tight. In metal caissons, also, the joints must be carefully leaded and caulked to withstand the interior air pressure and outside water pressure. When the construction above the roof is of concrete, reinforcement near the bottom of the concrete may make it practically self-supporting, and the roof needs only sufficient strength to carry the concrete until it has hardened. The concrete may also be expected to exclude the water more effectively than caulking.

The roofs of the caissons for the Municipal bridge over the Mississippi at St. Louis consisted of a single layer of 12-inch timbers with sheeting of 3-inch planks, on both upper and lower surfaces, placed diagonally and well caulked. This acted as a form for the concrete filling, which was reinforced near the lower surface with 1-inch bars, 6 inches apart both longitudinally and transversely.<sup>1</sup>

In small caissons for foundations of buildings, temporary roofs are sometimes employed, which serve as forms for the concrete filling, and are removed before the working chamber is filled with concrete, in order to make the construction monolithic, with no separation between the bottom concrete and the filling.

In deep caissons, timber cribs are frequently used upon top of the working chamber, being made with solid end and side walls, braced with cross walls or timbers. Such cribs are usually filled with concrete, but in some instances they are built to carry the whole load of the superstructure, and filling is omitted in order to reduce the weight upon the foundation. As they must not extend above low water, cofferdams are required on top of the crib within which to build the masonry piers.

*The shafts* connecting the working chambers with the tops of the caissons are steel cylinders. When the caisson is of sufficient size separate shafts are used for men and materials. For moderate depths, where ladders are used by the men, the shaft is about 3 feet in diameter, but when elevators are employed, it is made larger. Shafts for transporting materials are generally about 2 feet in diameter, the shaft casings frequently being made so that they may be removed before the shaft is filled with concrete, thus eliminating the separation between the concrete used for filling the shaft and that in the shell outside and making a practically monolithic job when the working chamber has a concrete roof.<sup>2</sup>

In small caissons of moderate depth, the air-locks are placed at

<sup>1</sup> Engineering Record, October 15, 1910.

<sup>2</sup> Trans. Am. Soc. Civil Engineers, Vol. LXI, p. 211.

the top of the shafts, while in large and deep caissons, they may be near the bottom, but far enough above the working chamber to provide a refuge for the men in case of accident at the bottom. The lock is simply a small room with two doors, one leading into the outside air, the other into the compressed-air shaft, connected with the working chamber. The doors are arranged to be held tightly closed when the air pressure is unequal on their two sides. In passing through the lock, the men enter the lock by the upper door, which is then closed and the air pressure in the lock is gradually raised to that in the working chamber, after which the lower door is opened and the men pass into the lower shaft and working chamber.

**207. Sinking the Caissons.**—The method of constructing and placing a caisson must always be determined by local conditions. When the caisson is to be sunk through a considerable depth of water, it may be constructed on ways built on land and floated to the site where it is to be sunk, and if no suitable location is at hand on shore, it may be built on barges or pontoons, from which it can be launched or lowered into position. In shoal water, a platform on piles is sometimes built at or around the site, upon which the caisson may be erected and from which it may be placed in position. The working chamber is built and made air-tight, then a sufficient height of crib or cofferdam added to reach above the water when the caisson is grounded in the position in which it is to be sunk. It is then built up as the sinking progresses so as to keep the top above water.

For the foundations of buildings, the sinking of the caissons is started in open excavation at about the level of ground water. The working chambers when of small size are constructed at a bridge shop or a wood-working shop and hauled to the site of the building, and are then set up in position and a section of concrete shell constructed on top. The air locks are then placed and the sinking proceeds. In some instances, the whole caisson is built and filled with concrete to the top before sinking begins. As a rule, however, they are built in two or three sections heights of 30 or 40 feet being sunk at once. When the working chamber is of concrete, it is built in position for sinking upon cutting edges previously placed and held in position by the concrete forms.

In large caissons sunk through water, the concrete in the cribs provides sufficient weight to cause sinking to take place as the material is removed from beneath the caisson, without the use of temporary loadings. Sometimes water jets are used to reduce friction upon the sides. As in the smaller caissons used in building foundations, temporary loadings—frequently pig iron—are required to force the



caissons down, some means for handling such loadings easily must be provided. It is common practice to employ derricks, which handle the loads in blocks weighing 2000 to 5000 pounds, 100 to 500 tons total weight being generally needed.

*Excavated material* is removed from the working chamber in buckets through small shafts with special air-locks near the top. The buckets are usually operated by hoisting engines outside the shaft, but sometimes compressed-air cylinders in the shaft are used for the purpose. In the caissons for the Brooklyn Bridge foundations, an open shaft extended through the caisson into a sump below the bottom of the working chamber, the sump being filled with water to a height sufficient to balance the air pressure, the material being removed by dredging through this shaft, and thrown into the sump by the men in the working chamber.

*The blow-out or sand-lift method* may be used in the removal of sand or mud. It consists in blowing the material through a pipe by the use of the air pressure in the working chamber. An open pipe 4 or 5 inches in diameter leads upward from the working chamber with a valve near its lower end. The material is heaped about the lower end of the pipe and the valve opened, thus blowing the mud and sand out through the pipe—a method that has been found quite satisfactory in many instances. The pipe wears rapidly on account of the high velocity of the sand passing through it, and it is sometimes difficult to prevent fluctuations in the air pressure in the working chamber due to the amount of air suddenly withdrawn.

*The mud pump* is used for driving the sand and mud upward through a pipe by means of a stream of water under pressure. This method was first used by Mr. Eads in the caissons for the St. Louis arch bridge. The suction of the pump is placed in a sump which is kept filled with water at the bottom of the working chamber, and the material to be removed is shoveled into the sump by the men.

**208. Physiological Effects of Compressed Air.**—The depths below water surface to which the pneumatic method may be employed is dependent upon the ability of men to work in compressed air. Experience has shown that under careful management, men in good physical condition may safely be subjected to an air pressure of about 45 or 50 pounds above atmospheric pressure, and work has been successfully carried out in several instances at maximum depths of 110 to 115 feet below water surface. Very careful attention to the physical condition of the men and to the methods used in entering and leaving the compressed air are necessary to prevent injurious results.

When the men enter the air locks and the air pressure is gradually increased, a sensation of giddiness, with pain in the ears and oppressive heat is felt. When equilibrium between the air pressures outside and inside the body has been reached, a feeling of exhilaration results while breathing the more dense air. Labor in the compressed air is more exhausting than in the outside air, and is carried on in shorter shifts. As the pressure is reduced, on leaving the caisson, a sensation of intense cold is experienced, accompanied by an itching feeling under the skin. Warm clothing is necessary, and it is customary to serve hot coffee to the men as they leave the locks. These are the usual and normal sensations experienced by those working in compressed air. The effects are greater the first time the air is encountered, and the unpleasant sensations are gradually eliminated as experience teaches the proper method of meeting them.

*Caisson disease* is a malady which sometimes results from working in compressed air and develops severe pains in the joints, resembling rheumatism, causing the patient to double up, and is commonly known as the "bends." It is experienced only after returning to atmospheric pressure, and is sometimes relieved by returning to the compressed air and coming out again very slowly, medical locks being sometimes provided for this purpose. In many instances the patient is partially paralyzed, and when the attack is severe a long time may be required for recovery. In the most serious cases, congestion of the brain and sometimes death may result.

Much has been learned through experience concerning the methods of preventing and treating caisson disease since the pneumatic process has been in use. In sinking the caissons of the St. Louis bridge, 119 cases of caisson disease developed and 14 deaths occurred. The better control in later work has largely eliminated this danger, but failure to exercise sufficient care, or unforeseen contingencies, still frequently cause trouble from this source.

The rate of decompression in coming out of the compressed air is a matter of importance, and the time allowed is not usually sufficient, according to the opinions of most medical authorities, to insure safety. The length of working shift should be reduced as the pressure increases. The proper ventilation of the working chamber is of greater importance than for men working at atmospheric pressure, and arrangements must be made for frequent changes of air.

## ART. 58. BRIDGE PIERS AND ABUTMENTS

**209. Locations and Dimensions for Piers.**—In fixing the locations for piers of a bridge, there are a number of factors which it may be necessary to take into consideration. In a navigable stream, they must be arranged so as to obstruct the channel as little as possible and meet the regulations imposed by the Government. This may sometimes determine positions, length of span, and height of structure. The waterway requirements and possibility of the piers restricting the waterway to a serious extent must always be considered. The character of the foundation along the line of the bridge, and probable difficulty of placing foundations at various locations may sometimes influence the choice of positions for piers.

Financial considerations are always important. The total cost of the structure including piers and superstructure should be the minimum consistent with properly meeting the other requirements. The cost of superstructure increases approximately as the square of the length of span, while the cost of piers may be nearly proportional to their number. An arrangement may therefore be worked out in each instance which will give a minimum of cost for the entire structure.

Aesthetic considerations may also have an influence on pier location; the appearance of the structure is always an important matter and may sometimes control the design. The arrangement of spans to secure symmetry in the whole structure, with proper placing of dominating features ought to be carefully considered.

The shape to be given to a pier is determined by the requirements of each particular case. It must be designed safely to transmit to the foundation, the loads brought upon it, and to resist any lateral pressure due to wind or current, and the form to be given a horizontal section should offer as little resistance as possible to the flow of the stream in which it may be placed.

The most common form for piers in streams is that of a rectangle of length a little more than the width of the bridge, with triangular or curved ends. The pointed ends below high water are known as starlings, and are intended to reduce the disturbance to the stream flow and sometimes to act as ice breakers. Sometimes starlings are used only on the up-stream end of the pier, but more commonly the horizontal section is made symmetrical. The down-stream starling serves to prevent eddies below the pier, and to equalize the load over the foundation area. Starlings are necessary only below high water, and the upper part of the pier is sometimes made rectangular, but



more commonly the ends are semicircular (see Fig. 123) or the shape of the starling is continued to the top.

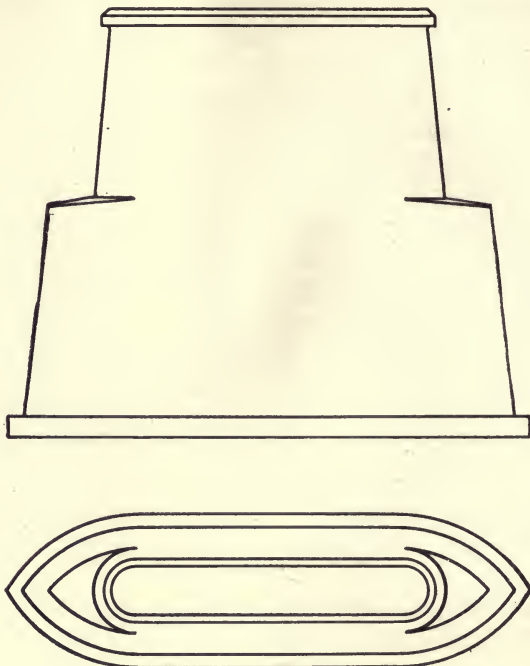

FIG. 123.

Fig. 124 shows a simple form of concrete pier in which a triangular starling is used upon the upstream end only and is continued to the top of the pier. In Fig. 123 the horizontal section of the starling is composed of two intersecting circular arcs of radius equal to the width of the pier, while the upper part of the pier has semicircular ends.

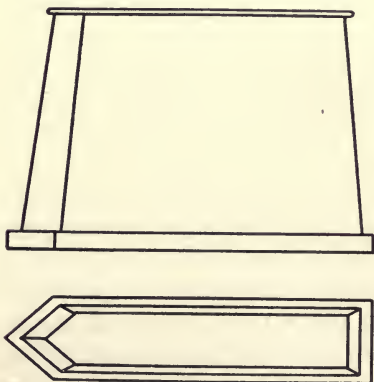

FIG. 124.

The dimensions required for the top of a pier are usually fixed mainly by the area of the bearings needed for the superstructure. A coping not less than

1 foot in thickness is placed on the top of the pier, projecting 3 to 6 inches beyond the top of the masonry beneath. The dimensions of

the top of the pier should be such that the base plate of the superstructure shall not come within 4 to 6 inches of the edges of the masonry under the coping. The width of the top of the pier under the coping is required to be at least 4 feet, and at least 1 foot more than is needed for the base plate.

A batter of at least  $\frac{1}{2}$  inch to 1 foot, or sometimes 1 inch to 1 foot, is given to the surfaces of the pier. Footing courses may be employed at the base of the pier to distribute the loads over a larger area of the foundation, being commonly stepped off, projecting about a foot horizontally and with a depth about twice the width. When of reinforced concrete the projecting steps may be designed as cantilever slabs.

*Cylinder piers* are frequently used when the sectional area of a single solid pier is not necessary to stability. These consist of a pair of cylinders arranged so that each may carry the ends of the trusses upon one side of the bridge, and are connected by bracing near the top to give rigidity transversely to the length of the bridge. They are either thin steel shells filled with concrete, or monolithic concrete shafts, reinforced near the outer surfaces.

**210. Stability of Piers.**—A masonry pier is a vertical column carrying both vertical and transverse loads. The vertical loads carried by any horizontal section of the pier consist of the weight of the superstructure with its live load and the weight of the pier above the section considered. The effect of impact is not usually considered, although a small allowance for impact is sometimes added for the upper part of railroad bridge piers.

The wind and current pressures are horizontal forces which tend to produce bending moments in any horizontal section of the pier, and in the foundation, in a direction normal to the bridge. The wind load upon the superstructure and upon a railway train upon the bridge may be taken the same as in designing the superstructure. Wind upon the end of the pier is commonly taken at about 20 pounds per square foot of vertical section for semicircular ends, but may be reduced to 15 pounds for pointed ends, and should be increased to 30 pounds for rectangular piers.

The pressure of a current of water upon the end of a pier cannot be accurately determined; in pounds per square foot of vertical section, it is frequently taken at about  $.75v^2$  (where  $v$  is the surface velocity of the stream in feet per second) for curved or pointed starlings and about twice this amount for rectangular piers. The center of pressure is assumed to be at one-third the depth from the surface to the bottom of the stream.

The pressure exerted by ice depends upon the thickness of the ice and the shape of the up-stream end of the pier, and is greatest when the ice is breaking up and a large body of floating ice is being cut by the pier. Where ice 10 or 12 inches thick may form, a pressure of 45,000 to 50,000 pounds per foot of width of pier is often assumed, considered as concentrated at the level of high water. For other thicknesses, the pressure is somewhat proportional to the thickness.

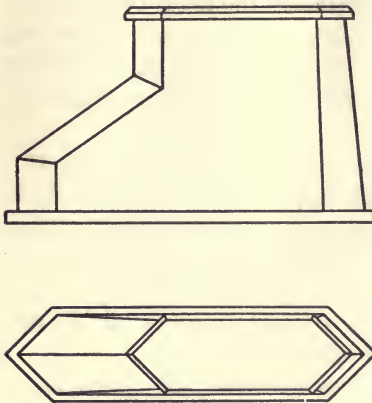

FIG. 125.

Where heavy ice is likely to form, the use of ice breakers, or starlings with edges inclined to the vertical (as shown in Fig. 125) may materially decrease the pressure.

The tractive force in the piers of a railway bridge is a horizontal force acting parallel with the length of the bridge at the level of the rail, and therefore produces moments in the horizontal sections of the pier and foundation at right angles to those due to wind and current. The tractive force is commonly taken

at  $2/10$  of the moving load on one track.

It is essential to stability that the maximum compressive stress upon any horizontal section due to the vertical loads combined with that due to the moments of the horizontal forces shall not exceed the safe compressive strength of the masonry. The maximum unit pressure upon the foundation must not exceed a safe value. No tension should exist in the masonry at any section under any possible loading, unless it be reinforced concrete designed for tension, and compression must always exist over the whole area of the foundation.

The horizontal forces must not be sufficient to produce sliding upon any joint in the masonry or foundation, or to shear any section of concrete.

Ordinary solid piers dimensioned to give sufficient bearing area at the top and slightly battered will usually be amply strong. The distribution of loads over the foundation should, however, be carefully looked after.

Large masonry piers are frequently built hollow. The masonry under the base plates of the superstructure is considered to act as columns which transmit the vertical loads to the foundation, and the central part of the pier is regarded as bracing to stiffen the columns



and carry the lateral loads. A part of the masonry at the center of the pier may be left out without appreciably reducing its strength, thus reducing the weight upon the foundation and saving a considerable volume of masonry or concrete. Such an arrangement is shown in Fig. 126.

Hollow piers of reinforced concrete have been occasionally used. These have been designed in a number of ways, columns being used under the base plates of the superstructure, connected in some way by reinforced bracing. The exterior shape of these piers below high water is made the same as solid piers in order to produce minimum disturbance of stream flow.

The pier below high water is hollow, with reinforced side walls connecting the towers at the ends. Above high water, the towers

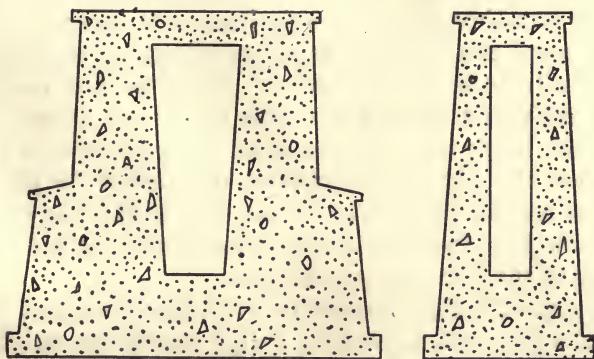

FIG. 126.

are separate and connected by a reinforced arch at the top. Openings are provided through the walls to admit water to the interior spaces.

**211. Construction of Piers.**—Solid bridge piers are constructed of concrete or of concrete with facing of cut stone. The use of rubble masonry as backing in such work has given way to concrete on account of its less cost and greater ease of handling.

Stone masonry facing has the advantage of presenting a pleasing appearance, and offering good resistance to the abrasion of the stream and of floating debris. In constructing a pier by its use forms are unnecessary, which frequently results in lessened cost of construction, although the cost of the masonry itself is greater than that of concrete. First-class ashlar masonry is required in such work, and the stone must be well bonded into the concrete backing. In important work carrying heavy loadings, the facing stones are tied to

the concrete by the use of steel rods attached to the stretchers at frequent intervals and extending well into the concrete.

When piers are wholly of concrete, it is desirable to place light reinforcement near the surface in the face of the pier to prevent surface cracks, which usually develop in any large exposed surface of concrete. This would require horizontal bars not more than 1 foot apart, and vertical bars every 2 or 3 feet, embedded about 2 inches in the concrete. The top of the coping should be similarly reinforced.

Cylinder piers are most commonly formed by constructing a cylindrical shell of steel and filling it with concrete. Reinforced concrete cylinders are also coming into use, and have the advantage of not requiring painting to prevent rust. A pair of cylinders is generally used for a pier and they are connected by bracing near the top or at two points for high piers. This bracing may be of reinforced concrete, or sometimes a steel truss inclosed in concrete.

The masonry of a pier may be supported upon a caisson, or upon hard material or piles in a cofferdam. When the pier rests upon a caisson, a cofferdam is built upon the top of the caisson and the masonry built inside the cofferdam after filling the caisson with concrete. When the pier rests upon piles, the tops of the piles extend upward into and are inclosed by the concrete in the base of the pier. In such work, it is desirable to place reinforcement in the bottom of the footing of the pier between the piles.

**212. Types of Bridge Abutments.**—A bridge abutment is a combination of a pier with a retaining wall; it carries the weight of one end of the bridge with its moving load and retains the bank of earth sustaining the roadway leading to the bridge, the requirements for stability being the same as those for a retaining wall. The weight of the bridge with its live load is brought upon the abutment near the top, and the thrust of the earth filling with that of the load upon the roadway is brought upon the back of the abutment, as shown in Fig. 127. These, with the weight of the pier itself, must give a proper distribution of pressures upon the foundation and safe stresses at any point in the masonry.

The filling supporting the roadway usually has side slopes about 1.5 horizontal to 1 vertical, which must be sustained by walls joined to the abutments. Abutments are divided according to the method used for supporting the side slopes into straight abutments, wing abutments, U abutments, and T abutments.

*Straight abutments* are those in which the walls retaining the side slopes are continuations of the abutments in the same lines, as shown in Fig. 127.

*Wing abutments* are those in which the side slopes are retained by wing walls, making an angle, usually about  $30^\circ$  with the face of the abutment (see Fig. 128). This type of abutment is selected where a

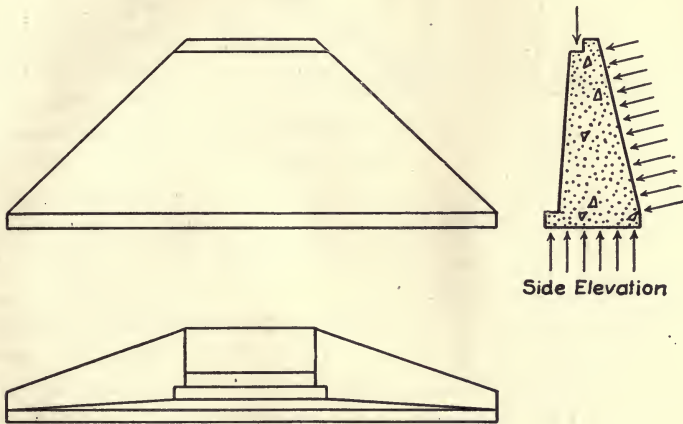

FIG. 127.—Straight Abutment.

stream flows past the face of the abutment, as it disturbs the flow of the stream to the least extent and protects the abutment against the stream getting behind it. The wing walls may be shorter and require

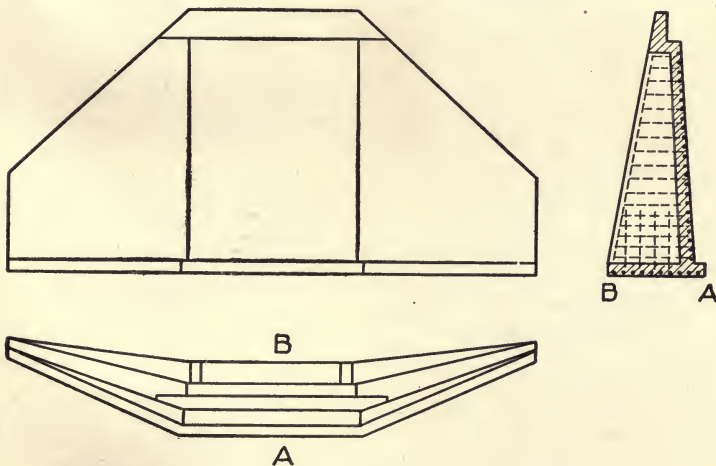
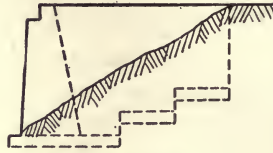

FIG. 128.

somewhat less masonry than the walls of straight abutments, when the bottom of the sloping earth is held back to the line of the face of the abutment.



U-*Abutments* are those in which the walls are turned at right angles to the abutment as shown in Fig. 129. The earth slope is then upon the face of the wall. They may be economical when the abutment is on the edge



Side Elevation

FIG. 129.

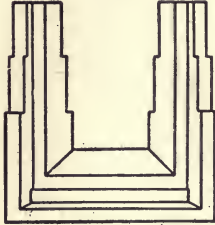

of a bluff so that the depth of the wall may be reduced by running into the face of the bluff.

Foundations of Bridges and Buildings by Jacoby and Davis, New York, 1914, gives a complete description of the various methods of constructing foundations, with detailed descriptions of many important constructions.

## INDEX

---

- Abutments, types of, 398  
—, U-, 400  
—, wing, 399  
Aggregates, kinds of, 111  
—, mechanical analysis of, 112, 118  
—, measuring fine, 40  
—, selection of, 115  
—, specific gravity, 113  
—, specifications for, 39  
—, tests for, 113  
—, voids in, 114  
American Railway Engineering Association, 69, 76, 362  
Arches, elastic, 295, 302  
—, analysis of, 314, 317, 334  
—, effect of direct thrust, 299  
—, temperature effects, 299  
—, theory of, 295  
Arches, hinged, 310  
—, reinforced, *see* Reinforced concrete arches  
—, Roman, 5  
—, unsymmetrical, 311  
—, voussoir, abutments for, 291  
—, —, earth pressures on, 288  
—, —, line of pressure in, 284, 292  
—, —, loads for, 286  
—, —, parts of, 282  
—, —, stability of, 283, 291  
—, —, thickness for, 289  
— with elastic piers, 312  
Ashlar masonry, 70, 73  
— —, strength of, 79  
— —, weight of, 80  
Assyrian architecture, 3, 4  
Beams, reinforced concrete, *see* Reinforced concrete beams  
Bond strength of reinforced concrete, 154, 173, 177, 186  
Brick, definition, 1  
— masonry, bond in, 94  
— —, cost of, 100  
— —, efflorescence in, 99  
— —, hollow walls, 97  
— —, joints in, 93  
— —, laying, 94  
— —, measurement of, 100  
— —, mortar for, 94, 101  
— —, strength of, 97  
— —, uses of, 2  
Bricks, clay and shale, 84-88  
—, classification of, 87  
—, clay for, 86  
—, composition of, 85  
—, pressed, 87  
—, vitrified, 88  
—, sand-lime, 88-90  
—, —, caustic lime process, 89  
—, —, hydrated lime process, 89  
—, —, properties of, 90  
—, sizes of, 92  
—, —, sun-dried, 3  
—, tests for, 91  
Bridge piers, construction of, 397  
— —, dimensions for, 393  
— —, hollow, 397  
— —, stability of, 395  
Bridges, concrete, girder, 278  
—, —, loading for, 271  
—, —, slab, 273  
—, —, T-beam, 275  
Building stone, 51-60  
— —, classification, 52  
— —, fire resistance, 60  
— —, seasoning, 61

- Building stone, strength of, 59  
 —, temperature effects, 59  
 —, tests for, 61
- Caissons, box, 376  
 —, cylinder, 380  
 —, dredging through wells, 383  
 —, open, 377  
 —, pneumatic, 387  
 —, steel, 385  
 —, timber, 378, 384
- Cantilever foundations, 375
- Cement, hardening of, 16  
 —, history of, 6  
 —, hydraulic, definition, 10  
 —, mixed, 21  
 —, natural, 20  
 —, permanence of volume, 23  
 —, Portland, *see* Portland cement  
 —, puzzolan, 21  
 —, Roman, 20  
 —, setting of, 16  
 —, silica, 22  
 —, slag, 21  
 —, specifications of 1916, 27
- Cement, Tests for, accelerated, 29  
 —, —, adhesive strength, 31  
 —, —, compressive strength, 30  
 —, —, standard, 27  
 —, —, soundness, 29  
 —, —, transverse strength, 30
- Cement mortar, materials required, 44  
 —, mixing, 42  
 —, proportioning, 39  
 —, retempering, 43  
 —, sand for, 31  
 —, strength of, 45  
 —, yield of, 44
- Chaldean construction, 3
- Chenoweth piles, 370
- Clay bricks, *see* Bricks, clay and shale
- Cofferdams, crib, 380  
 —, earth, 378  
 —, sheet-pile, 379
- Columns, concrete, 206  
 —, eccentric loads on, 212  
 —, examples in, 208, 211  
 —, hooped reinforcement, 209  
 —, longitudinal reinforcement, 207
- Compressed air, caisson disease, 392  
 —, —, physiological effects, 391
- Concrete, cost of, 149  
 —, consistency of, 130, 146  
 —, contraction joints, 133
- Concrete culverts, 326, 329, 331  
 —, durability of, 140  
 —, density of, 144, 146  
 —, expansion and contraction of, 133  
 —, fire resistance of, 143  
 — foundations, 352  
 —, —, design of, 354  
 —, freezing of, 131  
 — materials required for, 123  
 — mechanical analysis curve, 118  
 — mixers, 128  
 — mixing, 125  
 —, permeability of, 136  
 — piles, 367  
 —, placing, 130  
 —, proportioning, 116  
 —, reinforced, *see* Reinforced concrete  
 — rubble, 269  
 — surfaces, finishing, 135  
 —, strength of, 144  
 —, transportation of, 129  
 —, waterproofing, 137
- Conduits, analysis of gravity, 334  
 —, earth pressures on, 333  
 —, stresses in, 338
- Construction, Assyrian, 4  
 —, Chaldean, 3  
 —, Egyptian, 4
- Copings, 72, 75
- Costs of brick masonry, 100  
 — concrete, 149  
 — stone masonry, 83
- Coulomb's theory of earth pressure, 214
- Culverts, arch, 331  
 —, box, 327, 329  
 —, pipe, *see* Pipe culvert  
 —, types of, 321  
 —, waterway area, 321
- Dams, arched, 259-266  
 —, — constant angled, 262  
 —, — horizontal shear in, 261  
 —, — temperature stresses in, 263  
 —, construction of, 268  
 —, gravity, curved, 258  
 —, —, design of profile for, 251  
 —, —, distribution of pressures, 255  
 —, —, graphical analysis of, 249



- Dams, gravity, horizontal tensions in, 256  
 —, —, ice pressures on, 253  
 —, —, stability of, 247  
 —, —, uplift in, 253  
 —, masonry for, 269  
 —, multiple arched, 263  
 —, overflow, 269  
 —, reinforced concrete, 266
- Earth pressures, angle of friction, 220  
 — —, computation of, 218  
 — —, graphical method for, 221  
 — —, table of, 219  
 — —, theories of, 214
- Efflorescence in brick walls, 99
- Egyptian construction, 4
- Equilibrium polygon, 294
- Expansion and contraction of concrete, 133
- Fire resistance of concrete, 143
- Foundations, cantilever, 357  
 —, pile, *see* Pile foundations  
 —, pneumatic, caissons, *see* Caissons  
 —, —, compressed air, 391  
 —, —, sinking, 390  
 —, soils, *see* Soils  
 —, spread, 347  
 — —, concrete, 352  
 —, —, grillage, 349, 352  
 —, —, masonry, 348  
 —, —, steel, 350
- Freezing of concrete, 131
- Frost batter in walls, 246
- Gneiss, 53
- Granite, 52  
 —, durability of, 60  
 —, strength of, 59
- Grillage foundations, 349, 352
- Gypsum blocks, 107  
 — plasters, 48
- Hollow clay blocks, *see* Structural tiling
- Hydrated lime, 15, 94, 138
- Hydraulic index, 13
- Influence lines, 314
- Keene's cement, 49
- Lime, common, 9, 11  
 —, hydraulic, 11, 13  
 —, hydrated, 15, 94, 138  
 —, putty, 15
- Limestone, 53  
 —, durability of, 60  
 —, strength of, 58
- Loads for bridges, 271  
 — — arches, 286, 300
- Marble, 54  
 —, strength of, 59
- Masonry, brick, *see* Brick masonry  
 —, cyclopean, 269  
 —, rubble concrete, 269  
 —, stone, *see* Stone masonry
- Mortar, cement, *see* Cement mortar
- Piers, bridge, *see* Bridge piers
- Pile-drivers, 359
- Piles, bearing power, 364  
 — classification of, 358  
 —, concrete, 367  
 —, pedestal, 368  
 —, sand, 359  
 —, sheet, 371  
 —, timber, 362
- Pipe culverts, cast iron, 325  
 — —, concrete, 326  
 — — and walls, 325  
 — —, vitrified, 324
- Plasters, gypsum, 48  
 —, hard finish, 50
- Portland cement, 18  
 — —, burning, 19  
 — —, composition, 19, 24  
 — —, silica ratio, 26
- Proportioning concrete, 116  
 — — by trial, 120  
 — —, fineness modulus, 121
- Puzzolan cement, 21
- Pyrobar floor tile, 108
- Quicklime, 12
- Rankine's theory of earth pressure, 216
- Raymond concrete pile, 367
- Reinforced concrete, arches, analysis of, 302, 314, 317  
 — —, — division of arch ring, 301, 317  
 — —, — design of, 300

- Reinforced concrete, arches, loads for, 300  
 — —, — stresses in, 305  
 — —, — types of, 309
- Reinforced concrete beams, compression reinforcement, 186  
 — — —, design of, 176  
 — — —, diagonal tension in, 168, 178  
 — — —, flexure formulas, 158, 179, 186  
 — — —, shear in, 167, 177, 182  
 — — —, spacing of steel, 173  
 — — —, tables for, 162, 188  
 — — —, T-beams, 179, 183, 198
- Reinforced concrete, bond strength, 154, 173  
 — —, columns, 206  
 — —, history of, 7  
 — —, modulus of elasticity, 156
- Retaining walls, concrete, cantilever, 229, 231  
 — —, —, counterforted, 230, 238  
 — —, —, design of, 230, 238  
 — —, —, examples of, 231, 235, 238  
 — —, Baker's rules, 221  
 — —, earth pressure upon, 214  
 — —, empirical design, 225  
 — —, foundations for, 244  
 — —, graphical method, 221  
 — —, stability of, 223  
 — —, surcharged, 221, 238  
 — —, Trautwine's rules, 225
- Roman arches, 5
- Rubble masonry, 71  
 — —, strength of, 79  
 — —, weight of, 80
- Sand for mortar, 31  
 —, density of, 37  
 —, specifications for, 39  
 —, tests for, 34
- Sandstone, 54  
 —, durability of, 55, 60
- Sandstone, strength of, 58, 59
- Sea water, action on concrete, 141
- Setting of cement, 16
- Sheet-piling, 371
- Simplex concrete piles, 367
- Slab and buttress dams, 267
- Slabs, reinforced concrete, 194
- Soils, bearing capacity, 344, 346  
 —, examination of, 342  
 —, tests for, 345
- Steel for reinforced concrete, 155  
 —, bond strength of, 173, 177  
 —, tables for, 166, 199
- Stone building, *see* Building stone  
 — cutting, 62-70  
 — masonry, 1, 70-84  
 — —, ashlar, 70, 73  
 — —, bearing blocks, 80  
 — —, capstones, 80  
 — —, cost of, 82  
 — —, corbels, 82  
 — —, strength of, 78
- Structural tiling, 102  
 — —, wall construction, 105
- Syenite, 53
- T-beam bridges, 275
- T-beams, *see* Reinforced concrete beams
- Tests for aggregates, 113  
 — — bricks, 91  
 — — cements, 27  
 — — concrete, 147
- Voussoir arches, *see* Arches, voussoir
- Walls of stone masonry, 72
- Waterproof concrete, 137
- Water-tables, 75
- Window sills, 76
- Yield of concrete, 122



---

## Wiley Special Subject Catalogues

For convenience a list of the Wiley Special Subject Catalogues, envelope size, has been printed. These are arranged in groups—each catalogue having a key symbol. (See special Subject List Below). To obtain any of these catalogues, send a postal using the key symbols of the Catalogues desired.

- 1—Agriculture. Animal Husbandry. Dairying. Industrial Canning and Preserving.
- 2—Architecture. Building. Concrete and Masonry.
- 3—Business Administration and Management. Law.  
Industrial Processes: Canning and Preserving; Oil and Gas Production; Paint; Printing; Sugar Manufacture; Textile.

### CHEMISTRY

- 4a General; Analytical, Qualitative and Quantitative; Inorganic; Organic.
- 4b Electro- and Physical; Food and Water; Industrial; Medical and Pharmaceutical; Sugar.

### CIVIL ENGINEERING

- 5a Unclassified and Structural Engineering.
  - 5b Materials and Mechanics of Construction, including; Cement and Concrete; Excavation and Earthwork; Foundations; Masonry.
  - 5c Railroads; Surveying.
  - 5d Dams; Hydraulic Engineering; Pumping and Hydraulics; Irrigation Engineering; River and Harbor Engineering; Water Supply.
- 
-



---

---

**CIVIL ENGINEERING—Continued**

**5e** Highways; Municipal Engineering; Sanitary Engineering; Water Supply. **Forestry. Horticulture, Botany and Landscape Gardening.**

**6—Design. Decoration. Drawing:** General; Descriptive Geometry; Kinematics; Mechanical.

**ELECTRICAL ENGINEERING—PHYSICS**

**7—General and Unclassified; Batteries; Central Station Practice; Distribution and Transmission; Dynamo-Electro Machinery; Electro-Chemistry and Metallurgy; Measuring Instruments and Miscellaneous Apparatus.**

**8—Astronomy. Meteorology. Explosives. Marine and Naval Engineering. Military. Miscellaneous Books.**

**MATHEMATICS**

**9—General; Algebra; Analytic and Plane Geometry; Calculus; Trigonometry; Vector Analysis.**

**MECHANICAL ENGINEERING**

**10a** General and Unclassified; Foundry Practice; Shop Practice.

**10b** Gas Power and Internal Combustion Engines; Heating and Ventilation; Refrigeration.

**10c** Machine Design and Mechanism; Power Transmission; Steam Power and Power Plants; Thermodynamics and Heat Power.

**11—Mechanics.**

**12—Medicine. Pharmacy. Medical and Pharmaceutical Chemistry. Sanitary Science and Engineering. Bacteriology and Biology.**

**MINING ENGINEERING**

**13—General; Assaying; Excavation, Earthwork, Tunneling, Etc.; Explosives; Geology; Metallurgy; Mineralogy; Prospecting; Ventilation.**

**14—Food and Water. Sanitation. Landscape Gardening. Design and Decoration. Housing, House Painting.**

---

---



RETURN TO the circulation desk of any  
University of California Library  
or to the

NORTHERN REGIONAL LIBRARY FACILITY  
Bldg. 400, Richmond Field Station  
University of California  
Richmond, CA 94804-4698

---

ALL BOOKS MAY BE RECALLED AFTER 7 DAYS

2-month loans may be renewed by calling  
(415) 642-6753

1-year loans may be recharged by bringing books  
to NRLF

Renewals and recharges may be made 4 days  
prior to due date

---

DUE AS STAMPED BELOW

---

JUN 10 1991

---

---

---

---

---

---

---

---

---

---

---

---



436264

TA 670  
SS

UNIVERSITY OF CALIFORNIA LIBRARY

