

TG 270

.E3

Copy 1



Class TG 270

Book .E3

PRESENTED BY

RESEARCHES

IN

GRAPHICAL STATISTICS.

RESEARCHES

IN

GRAPHICAL STATISTICS.

BY

HENRY T. EDDY, C. E., Ph. D.,

PROFESSOR OF MATHEMATICS AND CIVIL ENGINEERING
IN THE UNIVERSITY OF CINCINNATI.

ILLUSTRATED BY FORTY-ONE ENGRAVINGS IN TEXT AND NINE FOLDING PLATES.

REPRINTED FROM VAN NOSTRAND'S ENGINEERING MAGAZINE.

NEW YORK:

D. VAN NOSTRAND, Publisher,
23 MURRAY STREET AND 27 WARREN STREET.

1878.

TG 270
E3

Copyright ;
1878,
By D. VAN NOSTRAND.

Gift -
Raymond E. Adams
S. 19. 19

19-194/6

PREFACE.

At a meeting of the American Association for the Advancement of Science, held in August, 1876, at Buffalo, the writer read two papers, entitled respectively, "Certain New Constructions in Graphical Statics," and "A New Fundamental Method in Graphical Statics." These papers, with considerable additions and amplifications, are presented on the following pages; and to them is added a third on *The Theory of Internal Stress*.

The paper, entitled *New Constructions in Graphical Statics*, is largely occupied with the various forms of the elastic arch. The possibility of obtaining a complete graphical solution of the elastic arch in all cases depends upon a theorem not hitherto recognized as to the relative position of the equilibrium curve due to the loading and the curve of the arch itself. The demonstration of this theorem, which may be properly named the Theorem Respecting the Coincidence of Closing Lines, as given on page 12, is somewhat obscure. However, a second demonstration is given on page 98, and this latter, stated at somewhat greater length, may also be found in the *American Journal of Pure and Applied Mathematics*, Vol. I, No. 3. Prof. Wm. Cain, A.M., C.E., has also published a third demonstration in *Van Nostrand's Magazine*, Vol. XVIII. The solution of the elastic arch is further simplified so that it depends upon that of the straight girder of the same cross section. Moreover, it is shown that the processes employed not only serve to obtain the moment, thrust and shear due the loading, but also to obtain those due to changes of temperature, or to any cause which alters the span of the arch. It is not known that a graphical solution of temperature stresses has been heretofore attempted.

A new general theorem is also enunciated which affords the basis for a direct solution of the flexible arch rib, or suspension cable, and its stiffening truss.

These discussions have led to a new graphical solution of the continuous girder in the most general case of variable moment of inertia. This is accompanied by an analytic investigation of the Theorem of Three Moments, in which the general equation of three moments appears for the first time in simple form. This investigation, slightly extended and amplified, may be also found in the *American Journal of Pure and Applied Mathematics*, Vol. I, No. 1.

Intermediate between the elastic and flexible arch is the arch with block-work joints, such as are found in stone or brick arches. A graphical solution of this problem was given by Poncelet, which may be found in Woodbury's treatise on the *Stability of the Arch*, page 404. Woodbury states that this solution is correct in case of an unsymmetrical arch, but in this he is mistaken. The solution proposed in the following pages is simpler, susceptible

of greater accuracy, and is not restricted to the case when either the arch or loading is symmetrical about the crown.

The graphical construction for determining the stability of retaining walls is the first one proposed, so far as known, which employs the true thrust in its real direction, as shown by Rankine in his investigation of the stress of homogeneous solids. It is in fact an adaptation of that most useful conception, Coulomb's *Wedge of Maximum Thrust*, to Rankine's investigation.

It has also been found possible to obtain a complete solution of the dome of metal and of masonry by employing constructions analogous to those employed for the arch; and in particular, it is believed that the dome of masonry is here investigated correctly for the first time, and the proper distinctions pointed out between it and the dome of metal.

In the paper entitled, *A New General Method in Graphical Statics*, a fundamental process or method is established of the same generality as the well-known method of the Equilibrium Polygon. The new method is designated as that of the Frame Pencil, and both the methods are discussed side by side in order that their reciprocal relationship may be made the more apparent. The reader who is not familiar with the properties of the equilibrium polygon will find it advantageous to first read this paper, or, at least, defer the others until he has read it as far as page 83.

As an example affording a comparison of the two methods, the moments of inertia and resistance have been discussed in a novel manner, and this is accompanied by a new graphical discussion of the distribution of shearing stress.

In the paper entitled, *The Theory of Internal Stress in Graphical Statics*, there is considerable new matter, especially in those problems which relate to the combination of states of stress, a subject which has not been, heretofore, sufficiently treated.

It is hoped that these graphical investigations which afford a pictorial representation, so to speak, of the quantities involved and their relations may not present the same difficulties to the reader as do the intricate formulæ arising from the analytic solutions of the same problems. Indeed, analysis almost always requires some kind of uniformity in the loading and in the structure sustaining the load, while a graphical construction treats all cases with the same ease; and especially are cases of discontinuity, either in the load or structure, difficult by analysis but easy by graphics.

H. T. E.

CONTENTS.

NEW CONSTRUCTIONS IN GRAPHICAL STATICS.

	PAGE.
The Fundamental Propositions and Equations of the Elastic Arch.....	9
Arch Rib with Fixed Ends.	14
Arch Rib with Fixed Ends and Hinge Joint at the Crown.....	20
Temperature Strains.....	23
Unsymmetrical Arches.....	25
Arch Rib with End Joints.....	25
Arch Rib with Three Joints.....	27
Arch Rib with One End Joint.....	28
Arch Rib with Two Joints.....	29
Suspension Bridge with Stiffening Truss.....	30
Continuous Girder with Variable Cross Section.....	36
Theorem of Three Moments.....	41
Flexible Arch Rib and Stiffening Truss.....	43
Arch of Masonry.....	45
Retaining Walls and Abutments.....	49
Foundations in Earth.....	53
Spherical Dome of Metal.....	53
Spherical Dome of Masonry.....	56
Conical Dome of Metal.....	59
Conical Dome of Masonry.....	60
Other Vaulted Structures.....	61

A NEW GENERAL METHOD IN GRAPHICAL STATICS.

Reciprocal Figures.....	65
Roof Truss, Wind and Weight Stresses.....	67
Bridge Truss, Maximum Stresses.....	68
Wagon Wheel with Tension-Rod Spokes. . .	72

	PAGE.
Water Wheel with Tension-Rod Spokes.....	73
Equilibrium Polygon for Forces in One Plane.....	74
Frame Pencil for Forces in One Plane.....	76
Equilibrium Forces for Parallel Forces.....	78
Frame Pencil for Parallel Forces.....	80
Summation Polygon.....	82
Girder with Fixed Ends, by both Methods.....	83
Any Forces in One Plane applied at Given Points.....	86
Kernel, Moments of Resistance and Inertia, treated by the Equilibrium Polygon.....	86
Kernel, Moments of Resistance and Inertia, treated by the Frame Pencil.....	90
Uniformly Varying Stress in General.....	91
Distribution of Shearing Stress.....	92
Relative Stresses.....	94
Stresses in a Horizontal Chord.....	97
Addendum to Page 12.....	98
Addendum to Page 10.....	99

THE THEORY OF INTERNAL STRESS IN GRAPHICAL STATICS.

Introductory Definitions, etc.....	103
General Properties of Plane Stress.....	104
Problems in Plane Stress.....	110
Combination and Separation of States of Stress.....	116
Properties of Solid Stress.....	119
Problems in Solid Stress.....	120

ERRATA.

Page 12, line 12, first column, for "these" put "their."

" 42, " 16, " " " (M_i) " ($M_1 i$).

" 51, " 4, " " " ab " aa'

" 51, " 4, " " " $a'b'$ " bb'

" 55, " 26, " " " a " a_1

" 66, " 11, second " " B. Cremona put L. Cremona.

NEW CONSTRUCTIONS
IN
GRAPHICAL STATICS.

NEW CONSTRUCTIONS

IN

GRAPHICAL STATICS.

CHAPTER I.

It is the object of this work to fully discuss the stability of all forms of the arch, flexible or rigid, by means of the equilibrium polygon—the now well recognized instrument for graphical investigation. One or two other constructions of interest may also be added in the sequel. The discussion will pre-suppose an elementary knowledge of the properties of the equilibrium polygon, and its accompanying force polygon, for parallel forces.

As ordinarily used in the discussion of the simple or continuous girder, the equilibrium polygon has an entirely artificial relation to the problem in hand, and the particular horizontal stress assumed is a matter of no consequence; but not so with respect to the arch. As will be seen, there is a special equilibrium polygon appertaining to a given arch and load, and in this particular polygon the horizontal stress is the actual horizontal thrust of the arch. When this thrust has been found in any given case, it permits an immediate determination of all other questions respecting the stresses. This thrust has to be determined differently in arches of different kinds, the method being dependent upon the number, kind, and position of the joints in the arch.

The methods we shall use depend upon our ability to separate the stresses induced by the loading into two parts; one

part being sustained in virtue of the reaction of the arch in the same manner as an inverted suspension cable (*i.e.*, as an equilibrated linear arch), and the remainder in virtue of its reaction as a girder. These two ways in which the loading is sustained are to be considered somewhat apart from each other. To this end it appears necessary to restate and discuss, in certain aspects, the well-known equations applicable to elastic girders acted on by vertical pressures due to the load and the resistances of the supports.

Let P represent any one of the various pressures, P_1, P_2, P_n , applied to the girder.

Consider an ideal cross section of the girder at any point O .

Let x = the horizontal distance from O to the force P .

Let R = the radius of curvature of the girder at O .

At the cross section O , the equations just mentioned become:—

Shearing stress, $S = \Sigma (P)$

Moment of flexure, $M = \Sigma (Px)$

Curvature, $P' = \frac{1}{R} = \frac{M}{EI}$

Total bending, $B = \Sigma (P') = \Sigma \left(\frac{M}{EI} \right)$

Deflection, $D = \Sigma (P'x) = \Sigma \left(\frac{Mx}{EI} \right)$

in which E is the modulus of elasticity of the material, and I is the moment of inertia of the girder; and as is well known, the summation is to be extended from the point O to a free end of the girder, or, if not to a free end, the summation expresses the effect only of the quantities included in the summation.

Let a number of points be taken at equal distances along the girder, and let the values of P , S , M , B , D be computed for these points by taking O at these points successively, and also erect ordinates at these points whose lengths are proportional to the quantities computed. First, suppose I is the same at each of the points chosen, then the values of these ordinates may be expressed as follows, if a , b , c , etc., are any real constants whatever :

$$y_p = a \cdot P \quad . \quad . \quad (1)$$

$$y_s = b \cdot \Sigma(P) \quad . \quad . \quad (2)$$

$$y_m = c \cdot \Sigma(Px) = c \cdot M \quad . \quad (3)$$

$$y_b = d \cdot \Sigma(M) \quad . \quad . \quad (4)$$

$$y_d = e \cdot \Sigma(Mx) \quad . \quad . \quad (5)$$

If I is not the same at the different cross sections, let $P=M \div I$; then the last three equations must be replaced by the following:

$$y_m' = f \cdot P' \quad . \quad . \quad (3')$$

$$y_b' = g \cdot \Sigma(P') \quad . \quad . \quad (4')$$

$$y_d' = h \cdot \Sigma(P'x) \quad . \quad . \quad (5')$$

The ordinates y_m and y_m' are not equal, but can be obtained one from the other when we know the ratio of the moments of inertia at the different cross sections.

Equation (1) expresses the loading, and y_p may be considered to be the depth of some uniform material as earth, shot or masonry constituting the load. Lines joining the extremities of these ordinates will form a polygon, or approximately a curve which is the upper surface of such a load. When the load is uniform the surface is a horizontal line.

For the purposes of our investigation, a distributed load whose upper

surface is the polygon or curve, above described, is considered to have the same effect as a series of concentrated loads proportional to the ordinates y_p acting at the assumed points of division. If the points of division be assumed sufficiently near to each other, the assumption is sufficiently accurate.

If a polygon be drawn in a similar manner by joining the extremities of the ordinates y_m computed from equation (3), it is known that this polygon is an equilibrium polygon for the applied weights P , and it can also be constructed directly without computation by the help of a force polygon having some assumed horizontal stress.

Now, it is seen by inspection that equations (3) and (5), or (3') and (5'), have the same relationship to each other that equations (1) and (3) have. The relationship may be stated thus:—If the ordinates y_m (or y_m') be regarded as the depth of some species of loading, so that the polygonal part of the equilibrium polygon is the surface of such load, then a second equilibrium polygon constructed for this loading will have for its ordinates proportional to y_d . But these last are proportional to the actual deflections of the girder.

Hence a second equilibrium polygon, so constructed, might be called the deflection polygon, as it shows on an exaggerated scale the shape of the neutral axis of the deflected girder.

The first equilibrium polygon having the ordinates y_m may be called the moment polygon.

It may be useful to consider the physical significance of equations (3), (4), (5), or (3'), (4'), (5').

According to the accepted theory of perfectly elastic material, the sharpness of the curvature of a uniform girder is directly proportional to the moment of the applied forces, and for different girders or different portions of the same girder, it is inversely proportional to the resistance which the girder can afford. Now this resistance varies directly as I varies, hence curvature varies as $M \div I$, which is equation (3) or (3').

Now curvature, or bending at a point, is expressed by the acute angle between two tangents to the curve at the distance of a unit from each other; and the total

bending, *i.e.* the angle between the tangent at O , and that at some distant point A is the sum of all such angles between O and the point A . Hence the total bending is proportional to $\Sigma(M \div I)$, the summation being extended from O to the point A , which is equation (4) or (4').

Again, if bending occurs at a point distant from O , as A , and the tangent at A be considered as fixed, then O is deflected from this tangent, and the amount of such deflection depends both upon the amount of the bending at A , and upon its distance from O . Hence the deflection from the tangent at A is proportional to $\Sigma(Mx \div I)$ which is equation (5) or (5').

It will be useful to state explicitly several propositions, some of which are implied in the foregoing equations. The importance and applicability of some of them has not, perhaps, been sufficiently recognized in this connection.

Prop. I. Any girder (straight or otherwise) to which vertical forces alone are applied (*i.e.*, there is no horizontal thrust) sustains at any cross-section the stress due to the load, solely by developing one internal resistance equal and opposed to the shearing, and another equal and opposed to the moment of the applied forces.

Prop. II. But any flexible cable or arch with hinge joints can offer no resistance at these joints to the moment of the applied forces, and their moment is sustained by the horizontal thrust developed at the supports and by the tension or compression directly along the cable or arch.

It is well known that the equilibrium polygon receives its name from its being the shape which such a flexible cable, or equilibrated arch, assumes under the action of the forces. In this case we may say for brevity, that the forces are sustained by the cable or arch in virtue of its being an equilibrium polygon.

Prop. III. If an arch not entirely flexible is supported by abutments against which it can exert a thrust having a horizontal component, then the moment

due to the forces applied to the arch will be sustained at those points which are not flexible, partly in virtue of its being approximately an equilibrium polygon, and partly in virtue of its resistance as a girder.

It is evident from the nature of the equilibrium polygon that it is possible with any given system of loading to make an arch of such form (*viz.*, that of an equilibrium polygon) as to require no bracing whatever, since in that case there will be no tendency to bend at any point. Also it is evident that any deviation of part of the arch from this equilibrium polygon would need to be braced. As, for example, in case two distant points be joined by a straight girder, it must be braced to take the place of part of the arch. Furthermore, the greater the deviation the greater the bending moment to be sustained in this manner. Hence appears the general truth stated in the proposition.

It will be noticed that the moment called into action, at any point of a straight girder, depends not only on the applied forces which furnish the polygonal part of the equilibrium polygon, but also on the resistance which the girder is capable of sustaining at joints or supports, or the like. For example, if the girder rests freely on its end-supports, the moment of resistance vanishes at the ends, and the "closing line" of the polygon joins the extremities of the polygonal part. If however the ends are fixed horizontally and there are two free (hinge) joints at other points of the girder, the polygonal part will be as before, but the closing line would be drawn so that the moments at those two points vanish. Similarly in every case (though the conditions may be more complicated than in the examples used for illustration) the position of the closing line is fixed by the joints or manner of support of the girders, for these furnish the conditions which the moments (*i.e.*, the ordinates of the equilibrium polygon) must fulfill. For example, in a straight uniform girder without joints and fixed horizontally at the ends, the conditions are evidently these; the total bending vanishes when taken from end to end, and the deflection of one end below the tangent at the other end also vanishes.

Prop. IV. If in any arch that equilibrium polygon (due to the weights) be constructed which has the same horizontal thrust as the arch actually exerts; and if its closing line be drawn from consideration of the conditions imposed by the supports, etc.; and if furthermore the curve of the arch itself be regarded as another equilibrium polygon due to some system of loading not given, and its closing line be also found from the same considerations respecting supports, etc., then, when these two polygons are placed so that these closing lines coincide and their areas partially cover each other, the ordinates intercepted between these two polygons are proportional to the real bending moments acting in the arch.

Suppose that an equilibrium polygon due to the weights be drawn having the same horizontal thrust as the arch. We are in fact unable to do this at the outset as the horizontal thrust is unknown. We only suppose it drawn for the purpose of discussing its properties. Let also the closing line be drawn, which may be done, as will be seen hereafter. Call the area between the closing line and the polygon, A . Draw the closing line of the curve of the arch itself (regarded as an equilibrium polygon) according to the same law, and call the area between this closing line and its curve A'' . Further let A' be the area of a polygon whose ordinates represent the actual moments bending the arch, and drawn on the same scale as A and A'' . Since the supports etc., must influence the position of the closing line of this polygon in the same manner as that of A , we have by Prop. III not only

$$A = A' + A''$$

which applies to the entire areas, but also

$$y = y' + y''$$

as the relation between the ordinates of these polygons at any of the points of division before mentioned, from which the truth of the proposition appears.

This demonstration in its general form may seem obscure since the conditions imposed by the supports, etc., are quite

various, and so cannot be considered in a general demonstration. The obscurity, however, will disappear after the treatment of some particular cases, where we shall take pains to render the truth of the proposition evident. We may, however, make a statement which will possibly put the matter in a clearer light by saying that A'' is a figure easily found, and we, therefore, employ it to assist in the determination of A' which is unknown, and of A which is partially unknown. And we arrive at the peculiar property of A'' , that its closing line is found in the same manner as that of A , by noticing that the positions of the closing lines of A and A' are both determined in the same manner by the supports, etc.; for the same law would hold when the rise of the arch is nothing as when it has any other value. But A'' is the difference of A and A' . Hence what is true of A and A' separately is true of their difference A'' , the law spoken of being a mere matter of summation.

From this proposition it is also seen that the curve of the arch itself may be regarded as the curved closing line of the polygon whose ordinates are the actual bending moments, and the polygon itself is the polygonal part of the equilibrium polygon due to the weights.

It is believed that Prop. IV contains an important addition to our previous knowledge as to the bending moments in an arch, and that it supplies the basis for the heretofore missing method of obtaining graphically the true equilibrium polygon for the various kinds of arches.

Prop. V. If bending moments M act on a uniform inclined girder at horizontal distances x from O , the amount of the vertical deflection y_d will be the same as that of a horizontal girder of the same cross section, and having the same horizontal span, upon which the same moments M act at the same horizontal distances x from O . Also, if bending moments M act as before, the amount of the horizontal deflection, say x_a , will be the same as that of a vertical girder of the same cross section, and having the same height, upon which the same moments M act at the same heights.

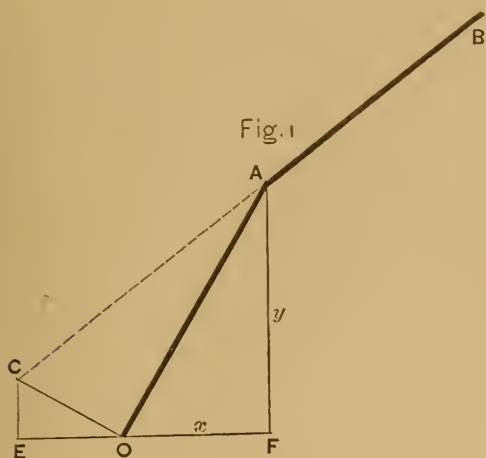

Let the moment M act at A , producing according to equation (5) the deflection

$$OC = e \cdot M \cdot AO$$

whose vertical and horizontal components are

$$y_d = CE \quad \text{and} \quad x_d = OE$$

For the small deflections occurring in a girder or arch, $\angle AOC = 90^\circ$

$$\therefore AO : OF :: OC : CE$$

$$\therefore CE = \frac{OC}{AO} \cdot OF = e \cdot M \cdot OF$$

$$\therefore y_d = e \cdot Mx$$

Also, $AO : AF :: OC : OE$

$$\therefore OE = \frac{OC}{AO} \cdot AF = e \cdot M \cdot AF$$

$$\therefore x_d = e \cdot My$$

The same may be proved of any other moments at other points; hence a similar result is true of their sum; which proves the proposition.

It may be thought that the demonstration is deficient in rigor by reason of the assumption that $\angle AOC = 90^\circ$.

Such, however, is not the fact as appears from the analytic investigation of this question by Wm. Bell in his attempted graphical discussion of the arch in Vol. VIII of this Magazine, in which the only approximation employed is that admitted by all authors in assuming that the curvature is exactly proportional to the bending moment.

We might in this proposition substitute $f \cdot M \div I$ for $e \cdot M$, and prove a similar but more general proposition re-

specting deflections, which the reader can easily enunciate for himself.

Before entering upon the particular discussions and constructions we have in view, a word or two on the general question as to the manner in which the problem of the arch presents itself, will perhaps render apparent the relations between this and certain previous investigations. The problem proposed by Rankine, Yvon-Villarcieux, and other analytic investigators of the arch, has been this:—Given the vertical loading, what must be the form of an arch, and what must be the resistances of the spandrels and abutments, when the weights produce no bending moments whatever? By the solution of this question they obtain the equation and properties of the particular equilibrium polygon which would sustain the given weights. Our graphical process completely solves this question by at once constructing this equilibrium polygon. It may be remarked in this connection, that the analytic process is of too complicated a nature to be effected in any, except a few, of the more simple cases, while the graphical process treats all cases with equal ease.

But the kind of solution just noticed, is a very incomplete solution of the problem presented in actual practice; for, any moving load disturbs the distribution of load for which the arch is the equilibrium polygon, and introduces bending moments. For similar reasons it is necessary to stiffen a suspension bridge. The arch must then be proportioned to resist these moments. Since this is the case, it is of no particular consequence that the form adopted for the arch in any given case, should be such as to entirely avoid bending moments when not under the action of the moving load.

So far as is known to us, it is the universal practice of engineers to assume the form and dimensions, as well as the loading of any arch projected, and next to determine whether the assumed dimensions are consistent with the needful strength and stability. If the assumption is unsuited to the case in hand, the fact will appear by the introduction of excessive bending moments at certain points. The considerations set forth furnish a guide to a new

assumption which shall be more suitable, it being necessary to make the form of the arch conform more closely to that of the equilibrium polygon for the given loading.

The question may be regarded as one of economy of material, and ease of construction, analogous to that of the truss bridge. In this latter case, constructors have long since abandoned any idea of making bridges in which the inclination of the ties and posts should be such as to require theoretically the minimum amount of material. Indeed, the amount of material in the case of a theoretic minimum, differs by such an inconsiderable quantity from that in cases in which the ties and posts have a very different inclination, that the attainment of the minimum is of no practical consequence.

Similar considerations applied to the arch, lead us to the conclusion that the form adopted can in every case be composed of segments of one or more circles, and that for the purpose of construction every requirement will then be met as fully as by the more complicated transcendental curves found by the writers previously mentioned. If considerations of an artistic nature render it desirable to adopt segments of parabolas, ellipses or other ovals, it will be a matter of no more consequence than is the particular style of truss adopted by rival bridge builders.

We can also readily treat the problem in an inverse manner, viz:—find the system of loading, of which the assumed curve of the arch is the equilibrium polygon. From this it will be known how to load a given arch so that there shall be no bending moments in it. This, as may be seen, is often a very useful item of information; for, by leaving open spaces in the masonry of the spandrels, or by properly loading the crown to a small extent, we may frequently render a desirable form entirely stable and practicable.

CHAPTER II.

THE ARCH RIB WITH FIXED ENDS.

LET us take, as the particular case to be treated, that of the St. Louis Bridge, which is a steel arch in the form of the

arc of a circle; having a chord or span of 518 feet and a versed sine or rise of one-tenth the span, *i. e.* 51.8 feet. The arch rib is firmly inserted in the immense skew-backs which form part of the upper portion of the abutments. It will be assumed that the abutments do not yield to either the thrust or weight of the arch and its load, which was also assumed in the published computations upon which the arch was actually constructed. Further, we shall for the present assume the cross section of the rib to have the same moment of inertia, I , at all points, and shall here only consider the stresses induced by an assumed load. The stresses due to changes in the length of the arch itself, due to its being shortened by the loading, and to the variations of temperature, are readily treated by a method similar to the one which will be used in this article, and will be treated in a subsequent chapter.

Let $b_s a b'_s$ in Fig. 2, be the neutral axis of the arch of which the rise is one-tenth the span. Let $axyz$ be the area representing the load on the left half of the arch, and $ax'y'z'$ that on the right, so that $y_p = a$. $P = xy$ on the left, and $y_p = x'y'$ on the right.

Divide the span into sixteen equal parts bb_1, bb'_1 , etc., and consider that the load, which is really uniformly distributed, is applied to the arch at the points a, a_1, a'_1 , etc., in the verticals through b, b_1, b'_1 , etc.; so that the equal weights P are applied at each of the points on the left of a and the equal weights $\frac{1}{2}P$ at each point on the right of a , while $\frac{3}{4}P$ is applied at a .

Take b as the pole of a force polygon for these weights, and lay off the weights which are applied at the left of a on the vertical through b_s , viz., $b_s w_1 = \frac{1}{2}P =$ the weight coming to a from the left; $w_1 w_2 = P =$ the weight applied at a_1 ; $w_2 w_3 = P =$ the weight applied at a_2 , etc. Using b still as the pole, lay off $b'_s w'_1 = \frac{1}{4}P =$ the weight coming to a from the right; $w'_1 w'_2 = \frac{1}{2}P =$ the weight applied at a'_1 , etc. This amounts to the same thing as if all the weights were laid off in the same vertical. Part are put at the left and part at the right for convenience of construction. Now draw bw_1 until it intersects the vertical 1 at c_1 ; then draw $c_1 c_2 \parallel bw_2$; and $c_2 c_3 \parallel bw_3$,

etc. In the same manner draw bw_1' to c_1' ; then $c_1'c_2' \parallel bw_2'$, etc. Then the broken line $bc_1 \dots c_8$ is the equilibrium polygon due to the weights on the left of a , and $bc_1' \dots c_8'$ is that due to the weights on the right. Had the polygon been constructed for the uniformly distributed load (not considered as concentrated), on the left we should have a parabola passing through the points $bc_1 \dots c_8$, and another parabola on the right through $bc_1' \dots c_8'$. From the properties of this parabola it is easily seen that c_8 must bisect w_4w_5 , as c_8' must also bisect $w_4'w_5'$; which fact serves to test the accuracy of our construction. This test is not so simple in cases of more irregular loading.

The equilibrium polygon c_8bc_8' is that due to the applied weights, but if these weights act on a straight girder with fixed ends, this manner of support requires that the total bending be zero, when the sum is taken of the bending at the various points along the entire girder; for, the position of the ends does not change under the action of the weights, hence the positive must cancel the negative bending. To express this by our equations:

$$yb = e. \sum(M) = 0 \therefore \sum(M) = 0.$$

This is one of two conditions which are to enable us to fix the position of the true closing line h_8h_8' in this case. The other condition results from the fact that the algebraic sum of all the deflections of this straight girder must be zero if the ends are fixed horizontally.

This is evident from the fact that when one end of a girder is built in, if a tangent be drawn to its neutral axis at that end, the tangent is unmoved whatever deflections may be given to the girder; and if the other end be also fixed, its position with reference to this tangent is likewise unchanged by any deflections which may be given to the girder. To express this by our equations:

$$ya = f. \sum(Mx) = 0 \therefore \sum(Mx) = 0$$

The method of introducing these conditions is due to Mohr. Consider the area included between the straight line c_8c_8' and the polygon c_8bc_8' as some species of plus loading; we wish to find what minus loading will fulfill the above two conditions. Evidently the whole

negative loading must be equal numerically to the whole positive loading, if we are to have $\sum(M) = 0$. Next, as the closing line is to be straight, the negative load $c_8c_8'h_8h_8'$ may be considered in two parts, viz., the two triangles, $c_8c_8'h_8$ and $c_8'h_8h_8'$. Let the whole span be trisected at t and t' , then the total negative loading may be considered to be applied in the verticals through t and t' , since the centers of gravity of the triangles fall in these verticals. Again, the positive loading we shall find it convenient to distribute in this manner: viz., the triangle c_8bc_8' applied in the vertical through b , the parabolic area $bc_1 \dots c_8$ in the vertical 4 which contains its center of gravity, and the parabolic area $bc_1' \dots c_8'$ in $4'$.

Now these areas must be reduced to equivalent triangles or rectangles, with a common base, in order that we may compare the loads they represent. Let the common base be half the span: then $bb_0 = pp'$ is the positive load due to the triangle c_8bc_8' ; and $\frac{2}{3}c_4c_0 = pp_1$, and $\frac{2}{3}c_4'c_0' = p'p_1'$ are the positive loads due to the parabolic areas.

Now assume any point q as a pole for the load line p_1p_1' and find the center of gravity of the positive loading by drawing the equilibrium polygon, whose sides are parallel to the lines of this force polygon: viz., use qp_1 and qp as the 1st and 2nd sides, and make $p'q' \parallel qp'$, and $q'q_1 \parallel qp_1'$. The first and last sides intersect at q_1 ; therefore the center of gravity of the positive loads must lie in the vertical through q_1 .

Now the negative loading must have its center of gravity in the same vertical, in order that the condition $\sum(Mx) = 0$ may be satisfied, for it is the numerator of the general expression for finding the center of gravity of the loading. The question then assumes this form: what negative loads must be applied in the verticals through t and t' that their sum may be p_1p_1' , and that they may have their center of gravity in the vertical through q_1 .

The shortest way to obtain these two segments of p_1p_1' is to join r and r' which are in the horizontals through p_1 and p_1' , and draw an horizontal through q_0 , which is the intersection of rr' with the vertical through q_1 ; then rr_1 and $r'r_1'$ are the required segments

of the negative load. For, let $r r_2 = p_1' p_1$ and take r' as the pole of the load $r r_2$; then, since $r_1 q_0 \parallel r_2 r'$ and $q_0 r' \parallel r r'$ we have the equilibrium polygon $r_1 q_0 r'$ fulfilling the required conditions.

Now these two negative loads $r_1 r_2 = r_1' r_1'$ and $r r_1$, are the required heights of the triangles $c_8 h_8 c_8'$ and $c_8 c_8' h_8'$; therefore lay off $c_8 h_8 = r' r_1'$ and $c_8' h_8' = r r_1$.

The closing line $h_8 h_8'$ can then be drawn, and the moments bending the straight girder will then be proportional to $h_1 c_1, h_2 c_2$, etc., the points of inflexion being where the closing line intersects the polygon. If the construction has been correctly made, the area above the closing line is equal to that below, a test easy to apply.

Let us now turn to the consideration of the curve of the arch itself, and treat it as an equilibrium polygon. Since the rise of the arch is such a small fraction of the span, the curve itself is rather flat for our purposes, and we shall therefore multiply its ordinates $ab, a_1 b_1$, etc., by any number convenient for our purpose: in this case, say, by 3. We thereby get a polygon $d_8 d d_8'$ such that $d b = 3 ab, d_1 b_1 = 3 d_1 b_1$, etc. If a curve be described through $d_8 \dots d \dots d_8'$ it will be the arc of an ellipse, of which d is the extremity of the major axis.

If we wish to find the closing line $k_8 k_8'$ of this curve, such that it shall make $\Sigma (M_a) = 0$ and $\Sigma (M_{dx}) = 0$, the same process we have just used is here applicable; but since the curve is symmetrical, the object can be effected more easily. By reason of the symmetry about the vertical through b , the center of gravity of the positive area above the horizontal through b lies in the vertical through b . The center of gravity of the negative area lies there also; hence the negative area is symmetrical about the center vertical; the closing line must then be horizontal. It only remains then to find the height of a rectangle having the same area as the elliptical segment, and having the span for its base. This is done very approximately by taking (in this case where the span is divided into 16 equal segments) $\frac{1}{3}$ the sum of the ordinates $b_1 d_1$, etc.

We thus find the height $b k$ and the horizontal through k is the required closing line.

Before effecting the comparison which

we intend to make between the polygons c and d (as we may briefly designate the polygons $c_8 b c_8'$ and $d_8 d d_8'$), let us notice the significance of certain operations which are of use in the construction before us. One of these is the multiplication of the ordinates of the polygon or curve a to obtain those of d . If a was inverted, certain weights might be hung at the points a_1, a_2 , etc., such that the curve would be in stable equilibrium, even though there are flexible joints at these points. Equilibrium would still exist in the present upright position under these same applied weights, though it would be unstable. If now, radiating from any point, we draw lines, one parallel to each of the sides $aa_1, a_1 a_2, aa_1'$, etc., of the polygon, then any vertical line intersecting this pencil of radiating lines will be cut by it in segments, which represent the relative weights needed to make a their equilibrium polygon. By drawing the vertical line at a proper distance from the pole, its total length, *i. e.*, the total load on the arch can be made of any amount we please. The horizontal line from the pole to this vertical will be the actual horizontal thrust of the arch measured on the same scale as the load. If a like pencil of radiating lines be drawn parallel to the sides of the polygon d and the load be the same as that we had supposed upon the polygon a , it is at once seen that the pole distance for d is one-third of that for a ; for, every line in d has three times the rise of the corresponding one in a , and hence with the same rise, only one-third the horizontal span. The increase of ordinates, then, means a decrease of pole distance in the same ratio, and vice versa. As is well known, the product of the pole distance by the ordinate of the equilibrium polygon is the bending moment. This product is not changed by changing the pole distance.

Again, suppose the vertical load-line of a force polygon to remain in a given position, and the pole to be moved vertically to a new position. No vertical or horizontal dimension of the force polygon is affected by this change, neither will any such dimension of the equilibrium polygon corresponding to the new position of the pole be different from that in the polygon corre-

sponding to the first position of the pole; the direction of the closing line, however, is changed. Thus we see that the closing line of any equilibrium polygon can be made to coincide with any line not vertical, and that its ordinates will be unchanged by the operation. It is unnecessary to draw the force polygon to effect this change.

Now to make clear the relationship between the polygons c and d , let us suppose, for the instant, that the polygon e has been drawn by some means as yet unknown, so that its ordinates from d , viz., $e_1 d_1 = y_1$, $e_2 d_2 = y_2$, etc., are proportional to the actual moments M_e which tend to bend the arch.

The conditions which then hold respecting these moments M_e , are three:—

$$\sum (M_e) = 0, \quad \sum (M_e x) = 0, \quad \sum (M_e y) = 0.$$

The first condition exists because the total bending from end to end is zero when the ends are fixed. The second and third are true, because the total deflection is zero both vertically and horizontally, since the span is unvariable as well as the position of the tangents at the ends. These results are in accordance with Prop. V. Now by Prop. III these moments M_e are the differences of the moments of a straight girder and of the arch itself; hence the polygon e is simply the polygon c in a new position and with a new pole distance. As moments are unchanged by such transformations, let us denote these moments by M_c . We have before seen that

$$\sum (M_c) = 0, \text{ and } \sum (M_c x) = 0$$

Subtract

$$\therefore \sum (M_c - M_e) = 0, \text{ and } \sum (M_c - M_e)x = 0$$

$$\therefore \sum (M_d) = 0 \text{ and } \sum (M_d x) = 0$$

From this it is seen that the polygon d must have its closing line fulfill the same conditions as the polygon c . This is in accordance with Prop. IV.

$$\text{Again, } \sum (M_e y) = \sum (M_c - M_d)y = 0$$

$$\therefore \sum (M_c y) = \sum (M_d y).$$

This last condition we shall use for

determining the pole distance of the polygon e , which is one-third of the actual thrust of the arch measured on the scale of the weights w_1, w_2 , etc. The physical significance of this condition may be stated according to Prop. V, thus: if the moments M_d are applied to a uniform vertical girder bd at the points b, b_1'', b_2'', b_3'' , etc., at the same height with b_1, d_1 , etc., they will cause the same total deflection $xd = e$. $\sum (M_d y)$ as will the moments M_c when applied at the same points. Hence if M_d are used as a species of loading, we can obtain the deflection by an equilibrium polygon. Suppose the load at d_1 is $d_1 k_1$, and that at d_2 is $d_2 k_2$, etc., then that at b_3 is $\frac{1}{2} b_3 k_3$. This approximation is sufficiently accurate for our purposes.

Now lay off on $l_1 l_1'$ as a load line $dm_3 = \frac{1}{2} b_3 k_3$, $m_3 m_7 = d_1 k_1$, $m_7 m_6 = d_2 k_2$, etc. The direction of these loads must be changed when they fall on the other side of the line k ; e.g., $m_5 m_4 = k_4 d_4$. If this process be continued through the entire arch m_5' (not drawn) will fall as far to the right of d as m_5 does to the left, and the last load will just reach to d again. This is a test of the correctness with which the position of the line $k_3 k_3'$ has been found. Now using any point as b for a pole, draw bm_3 to f_7 , then draw $f_7 f_6 \parallel bm_7$, $f_6 f_5 \parallel bm_6$, etc. The curve bf' is then the exaggerated shape of a vertical girder bd , fixed at b , under the action of that part of moments M_d which are in the left half of the arch. The moments M_d on the right may act on another equal girder, having the same initial position bd , and it will then be equally deflected to the right of bd . This is not drawn.

Again, suppose these vertical girders fixed at b are bent instead by the moments M_c . We do not know just how much these moments are, though we do know that they are proportional to the ordinates of the polygon c . Therefore make $dn_3 = \frac{1}{2} h_3 c_3$, $n_3 n_7 = h_1 c_1$, $n_7 n_6 = h_2 c_2$, etc. When all these loads are laid off, the last one $n_8' d = \frac{1}{2} h_8' c_8'$ must just return to d . This tests the accuracy of the work in determining the position of $h_3 h_3'$.

Now using b as a pole as before, construct the deflection curves bg and bg' . Since these two deflections, viz., $2 df$ and gg' ought to be the same, this fact

informs us that each of the ordinates $h_1 c_1, h_2 c_2$, must be increased in the ratio of $\frac{1}{2} gg'$ to df , in order that when they are considered as loads, they may produce a total deflection equal to $2df$. To effect this, lay off $bj = df$ and $bi = \frac{1}{2} gg'$, and draw the horizontals through i and j . At any convenient distance draw the vertical $i_0 j_0$, and draw bi_0 and bj_0 . These last two lines enable us to effect the required proportions for any ordinates on the left, and these or two lines of the same slope on the right to do the same thing on the right. *E. g.* lay off the ordinate $bi'_s = h'_s c'_s$, then the required new ordinate is bj'_s . Then lay off $ki'_s e'_s = bj'_s$. In the same manner find ke from hb , and ke_s from $h_s c_s$. In the same manner can the other ordinates $h_1 e_1$, etc., be found; but this is not the best way to determine the rest of them, for we can now find the pole and pole distance of the polygon e .

As we have previously seen, the pole distance is decreased in the same ratio as the ordinates of the moment curve are increased, therefore prolong bi_0 to v_1 , and draw a horizontal line through v_1 intersecting bj_0 at v_2 and the middle vertical at v_0 ; then is $v_2 v_0$ the pole distance decreased in the required ratio. Hence we move up the weight-line $w_1 w_8$ to the position $u_1 u_8$ vertically through v_2 ; and for convenience, lay off the weights $w'_1 w'_2$ at $u'_1 u'_2$, etc.

Furthermore, we know that the new closing-line is horizontal. To find the position of the pole o so that this shall occur, draw bv parallel to hh_8 , and from v the horizontal vo . As is well known, v divides the total weight into the two segments, which are the vertical resistances of the abutments, and if the pole o is on the same horizontal with v , the closing line will be horizontal.

Now having determined the positions of the points e_s, e, e'_s , starting from one of them, say e_8 , draw $e_8 e_7 \parallel ou_8, e_7 e_6 \parallel ou_7$, etc.; then if the work be accurate, the polygon will pass through the other two points e and e'_s . The bending moments of the arch d or the arch a at a_1, a_2 , etc., is the product of the pole distance $v_0 v_2 = v'o$ by the ordinates $d_1 e_1, d_2 e_2$, etc., respectively, and between these points a similar product gives the moment with sufficient accuracy. It would be useful for the sake of accuracy to

multiply the ordinates of the arch by some number greater than 3.

As a final test of the accuracy of the work, let us see whether $\sum (Mey)$ is actually zero, as should be. At d_7 , for example, $y = d_7 l_7$, and Me is proportional to $d_7 e_7$. Then $\overline{d_7 s_7}^2$ is proportional to $Me y$ at that point if $e_7 s_7$ is the arc of a circle, of which $e_7 l_7$ is the diameter. Similarly find $d'_7 s'_7$, etc. When e_4 for example falls above d_4 , the circle must be described on the sum of $l_4 d_4$ and $d_4 e_4$ as a diameter, and $\overline{d_4 s_4}^2$ is proportional to a moment of different sign from that at d_7 . We have distinguished the sign of the moments at the different points along the arch, by putting different signs before the letter s . It would have been slightly more accurate to have used only one-half the ordinates $b_s e_s$ and $b'_s e'_s$, but as they nearly equal in this case and of opposite sign, we have introduced no appreciable error.

Now at any point s lay off $ss_7 = d_7 s_7$, and at right angles to it $s_7 s_8 = b_s s_8$, then at right angles to the hypotenuse ss_8 make $s_8 s'_8 = d'_8 s'_8$, etc. Then the sum of the positive squares is ss'_1 , and similarly the sum of the negative squares is ss_1 . If these are equal, then $\sum (Mey)$ vanishes as it should, and the construction is correctly made.

It would have been equally correct to suppose the two vertical girders fixed at d , and bent by the moments acting. We could have determined the required ratio equally well from this construction. Further, in proving the correctness of the construction by taking the algebraic sum of the squares, we could have reckoned the ordinates, y , from any other horizontal line as well as from $l_8 l'_8$.

To find the resultant stress in the different portions of the arch, we must prolong $v'o$ to o' , say, (not drawn) so that the pole distance $v'o' = 3v'o$; then if we join o' and u_8 , $o'u_8$ will be the resultant stress in the segment $b_8 a_7$; $o'u_7$ will be the stress in $a_7 a_6$, etc., measured in the same scale as the weights $w_1 w_2$, etc. This resultant stress is not directly along the neutral axis of the arch.

The vertical shearing stress is constructed in the same manner as for a girder, by drawing one horizontal through w_8 between the verticals 7 and 8, another

through w_7 , between 7 and 6, etc. (not drawn). Then the shear will be the vertical distance between vo and these horizontals through w_8, w_9 , etc. It is seen that the shear will change sign on the vertical through b_1 with our present loading.

The actual position of the vertical through the center of gravity of the load may be found by prolonging the first and last sides of the polygon c . A weight $= \frac{1}{2}P = w_8 w_9$ ought, however, first to be applied at b_2 , and another $= \frac{1}{4}P = w_8' w_9'$ at b_8' . The shearing stress under a distributed load will actually change sign on the vertical so found. It will not pass far however from b_1 .

The resultant stress is the resultant of the horizontal thrust and the vertical shearing stress, and it can be resolved into a tangential thrust along the arch and a normal shearing stress. This resolution will be effected in Fig. 3 of the next chapter.

As to the position of the moving load which will produce the maximum bending moments, we may say that the position chosen, in which the moving load covers one-half the span, gives in general nearly this case. It is possible, however, to increase one or two of the moments slightly by covering a little more than half the span with the moving load.

The loading which produces maximum moments will be treated more fully in subsequent chapters.

The maximum resultant stress and maximum vertical shear occur in general when the moving load covers the whole span. The construction in this case is much simplified, as the polygon c is then the same on the right of b as it now is on the left, and the center of gravity of the area is in the center vertical; so that the closing line $h_8 h_8'$ is horizontal, and can be drawn with the same ease as $k_8 k_8'$ was drawn. We shall not, even in this case, be under the necessity of drawing the curves bg and bg' , which would be both alike; for, as may be readily seen, the sum of the positive moments M_c on the left must be very approximately equal to the positive moments M_a on the left, and the same thing is true for the negative

moments at the left. The same two equalities hold also on the right. From this we at once obtain the ratio by which the ordinates of the polygon c must be altered to obtain those of the polygon e .

This last approximation also shows us that for a total uniform load, the four points of inflection when the bending moment is zero, lie two above and two below the closing line. It is frequently a sufficiently close approximation in the case when the moving load covers only part of the span to derive the ratio needed by supposing that the sum of all the ordinates, both right and left, above the closing line in the polygon c must be increased, so that it shall equal the corresponding sum in the polygon d . If the sums taken below the closing lines give a slightly different result, take the mean value.

Thus the single construction we have given in Fig. 2, and one other much simpler than this, which can be obtained by adding a few lines to Fig. 2, give a pretty complete determination of the maximum stresses on the assumptions made at the commencement of the article.

One of these assumptions, viz., that of constant cross section (*i. e.* $I = \text{constant}$), deserves a single remark. In the St. Louis Arch I was increased one-half at each end for a distance of one-twelfth of the span. This very considerable change in the value of I slightly reduced the maximum moments computed for a constant cross section. From other elaborate calculations, particularly those of Heppel,* on the Britannia Tubular Bridge, it appears that the variation in the moments caused by the changes in cross section, which will adapt the rib to the stresses it must sustain, are relatively small, and in ordinary cases are less than five per cent. of the total stress. The same considerations are not applicable near the free ends of a continuous girder, where I may theoretically vanish. In the case before us, where the principal part of the stress arises not from the bending moments, but from the compression along the arch, the effect of the variation of I is very inconsiderable indeed.

* *Philosophical Magazine*, Vol. 40, 1870.

CHAPTER III.

ARCH RIB WITH FIXED ENDS AND HINGE JOINT AT THE CROWN.

LET the curve a of Fig. 3 represent the proportions of the arch we shall use to illustrate the method to be applied to arches of this character. The arch a is segmental in shape, and has a rise of one-fifth of the span. It is unnecessary to assume the particular dimensions in feet, as the above ratio is sufficient to determine the shape of the arch.

The arch is supposed to be fixed in the abutments, in such a manner that the position of a line drawn tangent to the curve a at either abutment is not changed in direction by any deflection which the arch may undergo. At the crown, however, is a joint, which is perfectly free to turn, and which will, then, not allow the propagation of any bending moment from one side to the other. In order that we may effect the construction more accurately, let us multiply the ordinates of the curve a by some convenient number, say 2, though a still larger multiplier would conduce to greater accuracy: We thus obtain the polygon d .

Having divided the span b into twelve equal parts b_1, b_2 , etc, (a larger number of parts would be better for the discussion of an actual case), we lay off below the horizontal line b on the end verticals, lengths which express on some assumed scale the weights which may be supposed to be concentrated at the points of division of the arch. If al is the depth of the loading on the left and $al' = \frac{1}{2}al$ that on the right, then $b_6w_1 + b_6'w_6'$ = the weight concentrated at a ; w_1w_2 = the weight at a_1 ; $w_1'w_2'$ = the weight at a_1' , etc. Using b as a pole, draw the equilibrium polygon c , whose extremities c_6 and c_6' bisect w_3w_4 and $w_3'w_4'$ respectively.

Now to find the closing line of this equilibrium polygon so that its ordinates shall be proportional to the bending moments of a straight girder of the same span, and of a uniform moment of inertia I , which is built in horizontally at the ends and has a hinge joint at its center; we notice in the first place that the bending moment at the hinge is zero, and hence the ordinate of the equilibrium polygon at this point vanishes. The closing line then passes through b the point in question. Furthermore it is

evident that if we consider the parts of the girder at the right and left of the center as two separate girders whose ends are joined at the center, these ends have each the same deflection, by reason of this connection.

This is expressed by means of our equations by saying that $\Sigma(Mx)$ when the summation is extended from one end to the center is equal to $\Sigma(Mx)$ when the summation is extended from the other end to the center, for these are then proportional to the respective deflections of the center. We may then write it thus :

$$\Sigma_{b_6}^b (Mx) = \Sigma_{b_6'}^b (Mx)$$

The equation has this meaning, viz : that the center of gravity of the right and left moment areas taken together is in the center vertical : for, taking each moment M as a weight, x is its arm, and Mx its moment about the center.

In order to find in what direction to draw the closing line through b so that it shall cause the moment areas together to have their center of gravity in the center vertical through b , let us draw a second equilibrium polygon using the moment areas as a species of loading.

The area on the left included between any assumed closing line as bb_6 (or bh_6) and the polygon bc_6 may be considered to consist of a positive triangular area bc_6b_6 (or bc_6h_6) and a negative parabolic area bc_6c_6' ; and similarly on the right a positive area $bc_6'b_6'$ (or $bc_6'h_6'$) and a negative area $bc_6'c_6'$.

At any convenient equal distances from the center as at p and p' , lay off these loads to some convenient scale. It is, perhaps, most convenient to reduce the moment areas to equivalent triangles having each a base equal to half the span: then take the altitudes of the triangles as the loads. This we have done, so that $pp_1 = \frac{1}{3}c_6c_3$, and $p'p_1' = \frac{1}{3}c_6'c_3'$. Now assume, for the instant, that closing line is b_6b_6' , which of course is incorrect, and make $p_1p_2 = b_6c_6$ and $p_1'p_2' = b_6'c_6'$, then these are the loads due to the positive triangular areas at the left and right respectively, while pp_1 and $p'p_1'$ are the negative parabolic loads.

Take o' as the pole of these loads, then pp' may be taken for the first side of the second equilibrium polygon. Draw $pq \parallel o'p_1$ and $p'q' \parallel o'p_1'$, and then from q

and q' draw parallels to $o'p_2'$ respectively. These last sides intersect at q_2 . The vertical through q_2 then contains the center of gravity of the moment areas when b_6, b_6' is assumed as the closing line.

A few trials will enable us to find the position of the closing line which causes the center of gravity to fall on the center vertical. We are able to conduct these trials so as to lead at once to the required closing line as follows. Since, evidently, $b_6c_6 + b_6'c_6' = h_6c_6 + h_6'c_6'$, it is seen that the sum of the positive loads is constant. Therefore make $p_2p_3 = p_2'p_3'$ and use p_1, p_3 and p_1', p_3' as the positive loads, in the same manner as we used p_1, p_2 and p_1', p_2' previously.

This will be equivalent to assuming a new position of the closing line. The only change in the second equilibrium polygon will be in the position of the last two sides. These must now be drawn parallel to $o'p_3$ and $o'p_3'$ respectively; and they intersect at q_3 . The vertical through q_3 contains the center of gravity for this assumed closing line. Another trial gives us q_4 .

Now if the direction of the closing line had changed gradually, then the intersection of the last sides of the second equilibrium polygon would have described a curve through q_2, q_3 and q_4 . If one of these points, as q_3 , is near the center vertical, then the arc of a circle $q_2q_3q_4$, will intersect it at q_5 indefinitely near to the point where the true locus of the points of intersection would intersect the center vertical.

Let us assume that q_5 is then determined with sufficient exactness by the circular arc $q_2q_3q_4$, and draw qq_5 and $q'q_5$ as the last two sides of the second equilibrium polygon. Now draw $o'p_5 \parallel qq_5$ and $o'p_5' \parallel q'q_5$, then $p_4, p_5 = c_6h_6$ and $p_4', p_5' = c_6'h_6'$ are the required positive loads, and h_6bh_6' is the position of the closing line such that the center of gravity of the moment areas is in the center vertical.

It is evident that the closing line of the polygon d considered as itself an equilibrium polygon is the horizontal line through d , for that will cause the center of gravity of the moment areas on the left and right, between it and the polygon d , to fall on the center vertical.

The next step in the construction is to

apply Prop. IV, for the determination of the bending moments.

That Prop. IV is true for an arch of this kind is evident; for, the loading causes bending moments proportional to the ordinates h_2c_2, h_3c_3 , etc., while the arch itself is fitted to neutralize, in virtue of its shape, moments which are proportional to k_2d_2, k_3d_3 , etc. The differences of the moments represented by these ordinates are what actually produce bending in the arch.

Now the ordinates of the type hc are not drawn to the same scale as those of the type kd , for each was assumed regardless of the other. In order that we may find the ratio in which the ordinates hc must be changed to lay them off on the same scale as kd it is necessary to use another equation of condition imposed by the nature of the joint and supports, viz:

$$\Sigma_{b_6}^a (M_a - M_c)y = \Sigma_{b_6}^a (M_a - M_c)y$$

$$\text{or } \Sigma_{b_6}^d (M_d - M_c)y = \Sigma_{b_6}^d (M_d - M_c)y$$

The left hand side of the equation is the horizontal displacement (*i.e.*, the total deflection) of the extremity a of the left half of the arch, due to the actual bending moments $(M_a - M_c)$ acting upon it: and the right hand side is the horizontal displacement of a the extremity of the right half of the arch due to the moments actually bending it. These are equal because connected by the joint.

The construction of the deflection curves due to these moments will enable us to find the desired ratio.

The ordinates kd and hc are rather longer than can be used conveniently, to represent the intensity of the moments concentrated at d_1, d_2 , etc, and c_1, c_2 , etc.: so we will use the halves of these quantities instead. Therefore lay off $dm_6 = \frac{1}{2}k_6b_6$, $m_6m_5 = \frac{1}{2}k_5d_5$, $m_5m_4 = \frac{1}{2}k_4d_4$, etc., and also $dn_6 = \frac{1}{2}h_6c_6$, $n_6n_5 = \frac{1}{2}h_5c_5$, etc.

We use only one-quarter of each end ordinate because the moment area supposed to be concentrated at each end has only one half the width of the moment areas concentrated at the remaining points of division.

Using b as a pole we find the deflection curve fb due to the moment M_a or M_d and the deflection curve gb due to the moments M_c on the left. On the right

we should find a deflection $d'f' = df$ not drawn, and similarly a deflection $d'g'$ not equal to $d'g$.

Now the equation we are using requires that the ordinates hc shall be elongated so that when used as weights the deflections shall be identical: *i.e.*, we must have $d'f = \frac{1}{2}gg'$. To effect the elongation, lay off $aj = df$ and $ai = \frac{1}{2}gg'$; and at any convenient distance on the horizontals ii_0 and jj_0 draw the vertical i_0j_0 ; then the lines ai_0 and aj_0 will effect the required elongation. For example, lay off $ai_0 = h_0c_0$, from which we obtain $aj_0 = k_0e_0$ for the left end ordinate, and similarly $aj'_0 = k'_0e'_0$.

The pole distance tt_1 , of the original polygon c must be shortened in the same ratio in which the ordinates are elongated. Hence the new pole distance of the polygon e is tt_2 .

Since $k_0k'_0$ is the closing line of the polygon e , and is horizontal, the pole of e is o , on the horizontal through h_0 ; for, h_0w_0 is the part of the applied weight sustained by the left support.

Now if the weight line be moved up to t_2 so that the applied weights are $u_1u'_1$ at the center, etc., and o is the pole, the polygon e may be described starting from d , and it will finally cut off the end ordinates k_0e_0 and $k'_0e'_0$ before obtained. Then will the ordinates of the type de be proportional to the moments actually bending the arch, and the moments will be equal to the products of de by tt_2 , in which de is measured on the scale of distance, and tt_2 on the scale adopted for the weights w_1w_2 , etc.

The accuracy of the construction is finally tested by taking $\sum(ds)^2 = 0$, an equation deduced from $\sum''(M_a - M_c)y = 0$, as explained in the previous article upon the St. Louis Arch. It is unnecessary to explain the details of this construction since as appears from Fig. 3 it is in all respects like that in Fig. 2.

Now let us find the intensity of the tangential compression along the arch and of the shearing normal to the arch. Since the pole distance tt_2 refers to the difference of ordinates between the polygons d and e , whose ordinates are double the actual ordinates, if we wish now to return to the actual arch a whose ordinates are halves of the ordinates of d , we must take a pole distance $tt_3 = 2tt_2$ and move the weight line so that it is the

vertical through t_3 . Then tt_3 is the actual horizontal thrust of this arch due to the weights; and ov_0 is the resultant stress in the segment a_5b_0 of the arch, which may be resolved into two components or_0 and v_0r_0 respectively parallel and perpendicular to a_5b_0 .

Then are or_0 and v_0r_0 respectively, the thrust directly along, and the shear directly across the segment a_5b_0 of the arch. Similarly or_5 and v_5r_5 represent the thrust along, and the shear across the segment a_5a_4 , and so on for other segments. These quantities are all measured in the same scale as that of the applied weights.

The shear changes sign twice, as will be seen from inspection of the directions in which the quantities of the type vr are drawn. The shear is zero wherever the curves d and e are parallel to each other. Thus the shear is nearly zero at b_0 , at a_2 and at some point between a_2' and a_3' .

The maxima and minima shearing stresses are to be found where the inclination between the tangents to the curves d and e are greatest.

The statements made in the previous article, respecting the position of the moving load which causes maximum bending moments, are applicable to this kind of arch also.

The maximum normal shearing stress will occur for the parts of the arch near the center, when the moving load is near its present position, covering one half of the arch. But the maximum normal shearing stress near the ends, may occur when the arch is entirely covered by the moving load, or when it may occur when the moving load is near its present position, it being dependent upon the rise of the arch, and the ratio between the moving and permanent load.

The maximum tangential compressions occur when the moving load covers the entire arch. The stresses obtained by the foregoing constructions, go upon the supposition that the arch has a constant cross-section, so that its moment of inertia does not vary, and no account is taken of the stresses caused by any changes of the length of the arch rib, due to variations of temperature or other causes. These latter stresses we shall now investigate for both of the kinds of arches which have been treated.

CHAPTER IV.

TEMPERATURE STRAINS.

It is convenient to classify all strains and stresses arising from a variation in the length of the arch, under the head of temperature, as such stresses could evidently have been brought about by suitable variations of temperature.

The stresses of this kind which are of sufficient magnitude to be worthy of consideration, besides temperature stresses are of two kinds, viz. the elastic shortening of the arch under the compression to which it is subjected, and the yielding of the abutments, under the horizontal thrust applied to them by the arch. This latter may be elastic or otherwise. It was, I believe, neglected in the computation of the St. Louis Arch, and no doubt with sufficient reason, as the other stresses of this kind were estimated with a sufficient margin to cover this also. Anything which makes the true span of the arch differ from its actual span causes strains of this character. By true span is meant the span which the arch would have if laid flat on its side on a plane surface in such a position that there are no bending moments at any point of it, while the actual span is the distance between the piers when the arch is in position. If the arch be built in position, but joined at the wrong temperature the true and actual spans do not agree and excessive temperature strains are caused.

Taking the coefficient of expansion of steel as ordinarily given, a change of $\pm 80^\circ\text{F}$. from the mean temperature would cause the St. Louis Arch to be fitted to a span of about $3\frac{1}{4}$ inches, greater or less than at the mean.

The problem we wish to solve then is very approximately this: What horizontal thrust must be applied to increase or decrease the span of this arch by $3\frac{1}{4}$ inches, and what other stresses are induced by this thrust. In Fig. 4 the half span is represented on the same scale as in Fig. 2. The only forces applied to the half arch are an unknown horizontal thrust H at b_8 and an equal opposite thrust H at a . The arch is in the same condition as it would be if Fig. 4 represented half of a gothic arch of a span = $2ab$, of which a was one abutment, and b_8 was the new crown at which a weight of

$2H$ was applied. The gothic arch would be continuous at the crown, but the abutment a would be mounted on rollers, so that although the direction of a tangent at a could not be changed, nevertheless the abutment could afford no resistance to keep the ends from moving apart, *i.e.* there is no thrust in the direction of ab , any more than there is along an ordinary straight girder.

In order to facilitate the accurate construction, let us multiply the ordinates of a by 3 and use the polygon d instead. Now the real equilibrium polygon of the applied forces H , is the straight line kk_8 . By real equilibrium polygon is meant, that one which has for its pole distance, the actual thrust of the arch. As we are now considering this arch, H is the applied force, and the thrust spoken of is at right angles to H . We have just shown this thrust to be zero. We have then to construct an equilibrium polygon for the applied force H with a pole distance of zero. The polygon is infinitely deep in the direction of H , and hence is a line parallel to H . This fixes its direction.

Its position is fixed from the consideration that the total bending is zero, (because the direction of the tangents at the extremities a and b_8 are unchanged), which is expressed by the equation

$$\Sigma(M_d) = 0.$$

This gives us the same closing line through k which we found in Fig. 2, and the ordinates of the type kd , are proportional to the moments caused by the horizontal thrust H .

Now lay off $dm_8 = \frac{1}{2}k_8b_8$, $m_8m_7 = k_7d_7$, etc., as in Fig. 2.

The problem of finally determining H , will be solved in two steps:

1°. We shall find the actual values of the moments to which the ordinates kd are proportional;

2°. We shall find H by dividing either of these moments by its arm.

By considering the equation

$$D_y EI = \Sigma(My)$$

given in Chapter I, in which D_y is the horizontal displacement, it is seen that if the actual moments are used for weights, and EI for the pole distance, we shall obtain, as the second equilibrium polygon, a deflection curve whose ordi-

nates are the actual deflections due to the moments. By actual moments, actual deflections, etc, is meant, that all of the quantities in the equation are laid off to the scale of distance, say *one* n^{th} of the actual size.

Now let the equation be written

$$nD_y \cdot \frac{1}{n}EI = \Sigma(My).$$

From which it is seen that if the ordinates be multiplied by n , so that on the paper they are of the same size as in the arch, we must use *one* n^{th} of the former pole distance, all else remaining unchanged.

Now for the St. Louis Arch, $EI = 39680000$ foot tons. Let us take 100 tons to the inch, as the scale of force: and since $bd = 3$ inches, the scale of distance n is found from the proportion

$$3 \text{ in.} :: 51.8 \text{ ft.} :: 1 : n = 210 \text{ nearly,} \\ \text{and } EI \div 100 n^2 = 9 \text{ in. nearly,}$$

which is the pole distance necessary to use with the actual deflection $\frac{1}{2}$ of $3\frac{1}{4}$ in. = $1\frac{1}{2}$ in., in order that the moments may be measured to scale. As it is inconvenient to use so large a distance as 9 in. on our paper, let us take $\frac{2}{3}$ of 9 in. = $3\frac{1}{3}$ in. nearly = dz for the pole distance, and $\frac{2}{3}$ of $1\frac{1}{2}$ in. = $4\frac{1}{3}$ in. = dy , for the deflection.

Now with z as a pole and the weights $dm_s, m_s m_r$, etc, draw the deflection curve bf , having the deflection = df . The moments M_d must be increased in such a ratio that the deflection will be increased from df to dy . Therefore draw the straight lines bf and by , which will enable us to effect the increase in the required ratio. For example, the moment $dm_1 = bi$ is increased to bj , and $dm_s = bj$ is increased to bj_s . Now measuring bj in inches and multiplying by 210 and by 100, we have found that $21000 bj = 1809$ foot tons = the moment at d or a .

And again, $21000 bj_s = 3747$ foot tons = the moment at b_s .

By measurement $210 dk = 17$ ft. and $210 bk = 34.8$ ft.

$$\therefore H = 1809 \div 17 = 106 \text{ tons, +} \\ \text{or } H = 3747 \div 34.8 = 108 \text{ tons -}$$

These results should be identical, and the difference between them of less than 2 per cent. is due to the error occasioned

by using the polygon d instead of the curve of the ellipse, and to small errors in measurement. With a larger figure and the subdivision of the span into a greater number of parts this error could be reduced. The value of H found for the St. Louis Arch by computation was 104 tons, but that was not on the supposition of a uniform moment of inertia I , and should be less than the value we have obtained.

Now this horizontal thrust H due to temperature and to any other thrusts of like nature as compression, etc, is of the nature of a correction to the thrust due to the applied weights. Thus in Fig. 2 we found $3ov'$ to be the thrust due to the applied weights, and on applying the correction we must use the two thrusts $3ov' + H$ and $3ov' - H$ as pole distances to obtain equilibrium polygons whose ordinates reckoned from the arch a will, when multiplied by its pole distance, give the true bending moments. The tangential and normal stresses can then be determined by resolution, precisely as in Fig. 3.

If it, however, appears desirable to compute separately the strains due to H , this may be more readily done than in combination with the stresses already obtained. We have already seen sufficiently how the bending moments due to H are found. In fact the moments are such as would be produced by applying H at the point where the horizontal through k cuts the polygon d , for this is the point of no moment, and may be considered for the instant as a free end of each segment, to each of which H is applied causing the moments due to its arm and intensity.

To find the tangential stress and shear, lay off in Fig. 4 $av = H$ and on it as a diameter describe a semicircle, and draw $ar_s \parallel a_r a_s$, $ar_r \parallel a_s a_r$ etc.; then will ar_s be the component of H along $a_r a_s$, and vr_s be the component of H directly across the same segment. In a similar manner the quantities of which ar on the type are the tangential stresses and the quantities vr are the shearing stresses caused by H .

The scale used for this last construction is about fifty tons to the inch.

Now H is positive or negative according as the temperature is increased above or diminished below the mean,

and these tangential and normal components, of course, change sign with H .

It should also be noticed in this connection that thrusts and bending moments, which are numerically equal but of opposite sign, are induced by equal contractions and expansions.

The stresses due to variation of temperature in the arch of Fig. 3, having a center joint, are constructed in Fig. 5.

It is evident from reasoning similar to that employed for the case just discussed, that the closing line dk of the polygon d is the equilibrium polygon of the thrust H induced by variation of temperature. Suppose we have changed the equation of deflections to the form,

$$mD_y \cdot \frac{EI}{mn^2} = \Sigma \left(\frac{M}{n} \cdot \frac{y}{n} \right),$$

in which, if $mD_y = dy$ and $EI \div mn^2 = dz$, then the moments M and the ordinates y will be laid off on the scale of 1 to n . This is equivalent to doing what was done in the previous case, where m was equal to $\frac{2}{3}$. The remainder of the process is that previously employed.

It should be noticed that we have in Figs. 4 and 5, incidentally discussed two new forms of arches, viz: in Fig. 4 that of an arch having its ends fixed in direction, but not in position; *i.e.*, its ends may slide but not turn, and in Fig. 5, that of an arch sliding freely and turning freely at the ends. The first of these arches has the same bending moments as a straight girder, fixed in direction at the ends, and the second of them has the same bending moments as a simple girder supported at its ends.

Errata.—The measurements of Fig. 4 given on page 24 do not agree with the scale on which the drawing is engraved. The following equations and quantities agree with the dimensions of Fig. 4, and are to be substituted instead of those given on page 24.

Let the scale of force be 100 tons to the inch, and since $bd = 4\frac{1}{2}$ inches, $4\frac{1}{2}$ in. : 51.8 ft. :: 1 : $n = 140$ nearly, and $EI \div 100n^2 = 20$ in. nearly, which is the pole distance to use with the actual deflection of the half span = $1\frac{5}{8}$ in.

Now take one fourth of this pole distance = 5 in. = dz , and four times the deflection = $6\frac{1}{2}$ in. = dy , as being more convenient to use; the moments, which

are the products of the deflections by the pole distance, will be unchanged by this process.

Now increase the ordinates in such a ratio that the deflection will be increased from df to dy . For example, the moment $dm_1 = bi$ is increased to bj , and $dm_2 = bi_2$ is increased to bj_2 . Now by measuring bj in inches and multiplying by 140 and by 100 we have found $14000 bj = 1809$ foot tons = the moment at a or d . And again, $14000 bj_2 = 3747$ foot tons = the moment at b_2 .

By measurement, $140 dk = 17$ ft.

and $140 bk = 34.8$ ft.

$\therefore H = 1809 \div 17 = 106$ tons +,
or $H = 3747 \div 34.8 = 108$ tons -.

Near the bottom of the second column of page 24, instead of ar_s, ar, vr_s, ar, vr , read av_s, av, vv_s, av, vv .

The scale used in the last construction in Fig. 4, is about $33\frac{1}{2}$ tons to the inch.

UNSYMMETRICAL ARCHES.

The constructions which have been given have been simplified somewhat by the symmetry of the right and left hand halves of the arch, but the methods which have been used are equally applicable if such symmetry does not exist, as it does not, if, for example, the abutments are of different heights.

In particular, for the unsymmetrical arch, its closing line is not in general horizontal, and must be found precisely as that for the equilibrium polygon due to the applied weights.

If, in Fig. 3, the hinge joint is not situated at the center, the arch is unsymmetrical, and the determination of the closing line due to the applied weights, is not quite so simple as in Fig. 3. It will be necessary to draw the trial lines through the joint by which the curve of errors q is found.

CHAPTER V.

ARCH RIB WITH END JOINTS.

Let the curve a of the arch to be treated have a span of six times the rise, as represented in Fig. 6, and having divided the span into twelve equal parts, make the ordinates of the type bd twice the ordinates ab .

Let a uniform load having a depth wy cover the two-thirds of the span at the left, and a uniform load having a depth

$xy' = \frac{1}{2}xy$ cover the one-third of the span at the right. Assume any pole distance, as of one-third of the span, and lay off $b_4w_1 = xy =$ one-half of the load supposed to be concentrated at the center; $w_1w_2 = 2xy =$ the load concentrated above b_1 , etc. Similarly at the left make $b_4'w_1' = xy =$ one-half the load above b_1 ; $w_1'w_2' = 2xy =$ the load above b_1' ; $w_2'w_3' = xy + xy' = \frac{2}{3}xy =$ the load above b_2' ; $w_3'w_4' = xy =$ the load above b_3' , etc.

From this force polygon draw the equilibrium polygon c , just as in Figs. 2 and 3.

Now the closing line of the equilibrium polygon for a straight girder with ends free to turn, must evidently pass so that the end moments vanish. Hence c_6c_6' is the closing line of the polygon c , and b_6b_6' is the closing line of the polygon d , drawn according to the same law. The remaining condition by which to determine the bending moments is:

$$\Sigma (M_d - M_c)y = 0 \quad \therefore \Sigma (M_d y) = \Sigma (M_c y)$$

which is the equation expressing the condition that the span is invariable, the summation being extended from end to end of the arch.

This summation is effected first as in Figs. 2 and 3, by laying off as loads quantities proportional to the applied moments concentrated at the points of division of the arch, and thus finding the second equilibrium polygon, or deflection polygon of two upright girders, bent by these moments.

Let us take one-fourth of each of the ordinates bd for these loads, *i.e.* $bm = \frac{1}{4}$ of $\frac{1}{2}bd$; $mm_1 = \frac{1}{4}b_1d_1$, etc.: also bn, nm_1 , etc., equal to similar fractions of the ordinates of the curve c . Using d as the pole for this load, we obtain the total deflection bf_6 on the left, and the same on the right (not drawn) due to the bending moments M_d .

Similarly g_6g_6' is the total deflection right and left due to the moments M_c .

Now the equation of condition requires that $\frac{1}{2}g_6g_6' = bf_6$. That this may occur, the ordinates of the polygon c must be elongated in the ratio of these deflections. To effect this, make $ai = \frac{1}{2}g_6g_6'$ and $aj = bf_6$, and on the horizontals through i and j at a convenient distance draw the vertical i_0j_0 ; then the lines ai_0 and aj_0 will effect the required elongation, as previously explained. To

obtain the center ordinate be , for example, make $ai' = bh \therefore aj' = be$. To find the new pole o , draw bv parallel to c_6c_6' and vo horizontal, as before explained.

If ai_0 cuts the load line at t_1 and the horizontal through t_1 cuts aj_0 at t_2 , then the vertical through t_2 is the new position of the load line and tt_2 is the new horizontal thrust.

Now using o as the pole of the load line u, u_1' etc., through t_2 draw the equilibrium polygon starting from e . It must pass through b_6 and b_6' , which tests the accuracy of the construction.

The construction may now be completed just as in Fig. 3, by doubling the pole distance, and finding the tangential thrust along the arch and the normal shear directly across the arch in the segments into which it is divided. The maximum thrust and tangential stress is obtained when the line load covers the entire span.

To compute the effect of changes of temperature and other causes of like nature in producing thrust, shear, bending moment etc., let us put the equation of deflections in the following form:

$$mD_y \cdot \frac{EI}{mn^2n'} = \Sigma \left(\frac{M}{nn'} \cdot \frac{y}{n} \right) \quad (D)$$

This equation may perhaps put in more intelligible form the processes used in Figs. 4 and 5, and is the equation which should be used as the basis for the discussion of temperature strains in the arch. In equation (D) n is the number by which the rise of the arch must be divided to reduce it to bd , *i.e.*, it is the scale of the vertical ordinates of the type bd , in Fig. 6, so that if bd was on the same scale as the arch itself, n would be unity. Again, n' is the scale of force, *i.e.*, the number of tons to the inch; and m is a number introduced for convenience so that any assumed pole distance p may be used for the pole distance of the second equilibrium polygon. In Fig. 6, $p = bd$.

We find m from the equation,

$$p = \frac{EI}{mn^2n'} \quad \therefore m = \frac{EI}{pn^2n'}$$

from which m may be computed, for EI is a certain known number of foot tons when the cross-section of the rib is given, p is

a number of inches assumed in the drawing, n and n' are also assumed. Now D_y is the number of inches by which the span is increased or decreased by the change of temperature, and mD_y is at once laid off on the drawing.

The quantities in equation (D) are so related to each other, that the left-hand member is the product of the pole distance and ordinate of the second equilibrium polygon, while the right-hand member is the bending moment produced by the loading $M \div nn'$, which loading is proportional to M . The curve f was constructed with this loading, and only needs to have its loads and ordinates elongated in the ratio of bf_0 to $\frac{1}{2} mD_y$ to determine the values of $M \div nn'$ at the various points of division of the arch. One-half of each quantity is used, because we need to use but one-half the arch in this computation. Two lines drawn, as in Figs. 4 and 5, effect the required elongation.

The foregoing discussion is on the implied assumption that the horizontal thrust caused by variation of temperature is applied in the closing line bb_0 of the arch, which is so evident from previous discussions as to require no proof here.

The quantity determined by the foregoing process is $M \div nn' = q$ say, a certain number of inches. Then $M = nn'q$, and $H = M \div y = n'q \div \frac{y}{n}$, in which $\frac{y}{n}$ is the length of the ordinate in inches on the drawing at the point at which M is applied.

The determination of the shearing and tangential stress induced by H is found by using H as the diameter of a circle, in which are inscribed triangles, whose sides are respectively parallel and perpendicular to the segments of the arch, precisely as was done in Figs. 4 and 5.

The whole discussion of the arch with end joints may be applied to an unsymmetrical arch with end joints. In that case, it would be necessary to draw a curve f' at the right as well as f at the left, and the two would be unlike, as g and g' are. This, however, would afford no difficulty either in determining the stresses due to the loads, or to the variations of temperature.

When the live load extends over two-thirds of the span, as in the Fig., the maximum bending moment is nearly in

the middle of that live load, and is very approximately the largest which can be induced by a live load of this intensity, while the greatest moment of opposite sign is found near the middle of the unloaded third of the span.

If the curve of the arch were a parabola instead of the segment of a circle, these statements would be exact and not approximate, as may be proved analytically. This matter will be further treated hereafter.

CHAPTER VI.

ARCH RIB WITH THREE JOINTS.

Let the joints be at the center and ends of the arch, as seen in Fig. 7. Let the loading and shape of the arch be the same as that used in Fig. 6. Now since the bending moment must vanish at each of the joints, the true equilibrium curve must pass through each of the joints; *i. e.*, every ordinate of the polygon c must be elongated in the ratio of db to bh . To effect this, make $di = bh$, and at a convenient distance on the horizontals through b and i draw the vertical i_0b_4 . Then the ratio lines di_0 and db_4 will enable us to elongate as required, or to find the new pole distance ti , diminished in the same ratio, by drawing the horizontal ti through i_0 . The new pole o is found in the same manner as in Fig. 6.

Now with the new pole o and the new load line through t , we can draw the polygon e starting at d . It must then pass through b_0 and b'_0 which tests the accuracy of the construction.

The maximum thrust, and tangential stress is attained when the live load covers the entire span.

Variations in length due to changes of temperature induce no bending moments in this arch, but there may be slight alteration in the thrust, etc., produced by the slight rising or falling of the crown due to the elongation or shortening of the arch. This is so small a displacement that it is of no importance to compute the stresses due to it. We have for the same reason, in the previous and subsequent constructions, omitted to compute the stresses arising from the displacement which the arch undergoes at various points by reason of its being bent. It would be quite possible to give a complete investigation of these stresses by analogous methods.

The construction above given is applicable to any arch with three joints. The arch need not be symmetrical, and the three joints can be situated at any points of the arch as well as at the points chosen above.

CHAPTER VII.

THE ARCH RIB WITH ONE END JOINT.

Let the arch be represented by Fig. 8, in which the load, etc., is the same as in Fig. 6.

The closing line must pass through the joint, for at this joint the bending moment vanishes.

A second condition which must be fulfilled is, that the total deflection below the tangent at the fixed end of a straight girder having one end joint vanishes, for the position of the joint is fixed. This is expressed by the equation

$$\Sigma(Mx) = 0,$$

in which the summation is extended from end to end.

This condition will enable us to draw the closing line of the polygon c , and also that of d . The problem may be thus stated:—In what direction shall a closing line such as c_6h' be drawn from c_6 so that the moment of the negative triangular area $c_6c_6'h'$ about c_6 shall be equal to the moment of the positive parabolic area c_6bc_6'

To solve this problem, first find the center of gravity of the parabolic area by taking it in parts. The parabolic area c_6bc_6' is a segment of a single parabola whose area is $\frac{2}{3}b_6b_6' \times c_0c_2 = \frac{1}{2}h_1 \times b_6b_6'$, when h_1 = the height of an equivalent triangle having the span for its base $\therefore h_1 = \frac{3}{8}c_0c_2$.

Lay off $l_6b_6 = c_0c_2$, and draw l_6b_6' $\therefore b_6l_6 = h_1$. Lay off $c_2'p_1 = h_1$ as proportional to the weight of the parabolic area. Again, $c_2'p$ is proportional to the weight of the triangle $c_6c_2'c_6'$. The parabolic area $c_2'c_6' = \frac{2}{3}c_0'c_4' \times b_2'b_6' = \frac{1}{2}h_2 \times b_6b_6'$, as before, $\therefore h_2 = \frac{4}{3}c_0'c_4'$, which may be found as h_1 was before.

Let $h_2 = pp_2$, then on taking any pole, as c_2 , of this weight line, we draw $qq_1 \parallel c_2c_2'$, since the left parabolic area has its center of gravity in the vertical through q_1 , and the triangular area in that through q , we draw $qq_1' \parallel c_2p$, to the vertical through q_1' , which contains the center of gravity of the right parabolic area. The position of q midway between the

verticals containing b and b_2 is slightly to the right of its true position, as it should be at one-third of the distance from the vertical through b to that through b_2 . This does not affect the nature of the process however.

Then $q_1q_2 \parallel c_2p_1$ and $q_1'q_2 \parallel c_2p_2$ give q_2 in the vertical through the center of gravity of the total positive area. The negative area, since it is triangular, has its center of gravity in the vertical through c_2' .

Now if the total positive bending moment be considered to be concentrated at its center of gravity and to act on a straight girder it will assume the shape $r_2q_2r_1$ of this second equilibrium polygon, and if a negative moment must be applied such that the deflection vanish, the remainder of the girder must be r_1r_2 , a prolongation of rr_1 . Now draw $c_2p_3 \parallel rr_1$, and we have $p_2p_3 = c_6'h'$ the height of the triangle of negative area. Hence $c_6'h'$ is the closing line, fulfilling the required conditions.

Again, to draw the closing line b_6k' according to the same law, we know that the center of gravity of the polygonal area d is in the center vertical. To find the height p_4p' , of an equivalent triangle having a base equal to the span, we may obtain an approximate result, as in Fig. 2, by taking one twelfth of the sum of the ordinates of the type bd , but it is much better to obtain an exact result by applying Simpson's rule which is simplified by the vanishing of the end ordinates. The rule is found to reduce in this case to the following:—The required height is one eighteenth of the sum of the ordinates with even subscripts plus one ninth of the sum of the rest.

Now this positive moment concentrated in the center vertical and a negative moment such as to cause no total deflection in a straight girder, will give as a second equilibrium polygon $r_2q_2'r_1'r_2'$; and if $c_2p_3' \parallel rr_1'$, then $p_4'p_3' = b_6'k'$ is the height of the triangular negative area, and the closing line is b_6k' .

Now the remaining condition is that the span is invariable, which is expressed by the equation

$$\Sigma(M_d - M_c)y = 0, \text{ or } \Sigma(M_d y) = \Sigma(M_c y).$$

Let us construct the deflection curve due to the moments M_d in a manner similar to that employed in Fig. 2. We lay off quantities dm_3, m_3m_4 , etc.,

equal to one-fourth of the corresponding ordinates of the curve d , and dn_3 , n_3n_4 , etc., one-fourth of the ordinates of the curve c . We use one-fourth or any other fraction or multiple of both which may be convenient. By using b for a pole we obtain the deflection curves f and f' for the moments proportional to M_d , and the curves g and g' for those proportional to M_c .

Now, Prop. IV. requires that the ordinates of the polygon c should be increased so that gg' shall become equal to ff' . Make $di = gg'$ and $dj = ff'$ and draw as before the ratio lines di_0 and dj_0 , then the vertical through t_1 is the new position of the load line.

Find the new length of bh which is ke , and with the new pole o , draw the polygon e starting at e . It must pass through b_6 . The new pole o is found thus: draw $bv \parallel hh'$, then v divides the weight line into two parts, which are the vertical resistances of the abutments. From v_1 draw $v_1o \parallel kk'$, then the closing line of the polygon e has the direction kk' .

A single joint at any point of an unsymmetrical arch can be treated in a similar manner.

A thrust produced by temperature strains will be applied along the closing line kk' , and the bending moments induced will be proportional to the ordinates of the polygon d from this closing line. The variation of span must be computed not for the horizontal span, but for the projections of it on the closing line kk' . The construction of this component of the total effect will be like that previously employed. Another effect will be caused in a line perpendicular to kk' . The variation of span for this construction, is the projection of the total horizontal variation on a line perpendicular to kk' , and the bending moments induced by this force applied at b_6 , and perpendicular to the closing line, will be proportional to the horizontal distances of the points of division from b_6 . As these constructions are readily made, and the shearing and tangential stresses determined from them, it is not thought necessary to give them in detail.

CHAPTER VIII.

ARCH RIB WITH TWO JOINTS.

Let us take the two joints, one at the center and one at one end as represented

in Fig. 9. Let the loading, etc., be as in Fig. 6.

The closing line evidently passes through the two joints, as at them the bending moment vanishes.

The remaining condition to be fulfilled is that the deflection of the right half of the arch in the direction of this line, shall be the same as that of the left half.

Let us then suppose that the straight girder $b_6'p'$ perpendicular to the closing line, is fixed at b_6' and bent first by the moments M_d giving us the deflection curve $b_6'f'$ when b_6' is taken as the pole, and the loads of the type mm are one-quarter of the corresponding ordinates of the polygon d ; and secondly, by the moments M_c giving us the deflection curve $b_6'g'$ when drawn with the same pole, and the loads of the type nn also one-quarter of the corresponding ordinates of the polygon c . It should be noticed that the points at which these moments are supposed to be concentrated in the girder $b_6'p'$, are on the parallels to kk' through the points d_3 , d_6 , etc.

Similarly let ff_3 and f_3f_6 be the deflection curves of the straight girder d_3p (using d_3 as the pole distance), under the applied moments.

We have used now a pole distance differing from that used in the right half of the arch. These pole distances must have the same ratio that the quantity EI has for the two parts of arch. If EI is the same in both parts of the arch the same pole distance must be used to obtain the deflection curves in both sides of the middle. In the same manner the curves gg_3 and g_3g_6 are found. Now must the moments M_c causing the total deflection $p'g' - gg_6 = \frac{1}{2}ai$ be elongated so that they shall cause a total deflection $pf' - ff_6 = \frac{1}{2}aj$. The ratio lines ai_0 , aj_0' will enable us to find the new position t_2 of the load line to effect this.

To find o the new pole, through v_2 , which divides the load line into parts which are the vertical resistances of the piers, draw $v_2o \parallel b_6k$. Then draw the polygon e as in Fig. 7, starting from d . It must pass through b_6 . We can find also whether ke_6' has the required ratio to hc_6' by the aid of the ratio lines, which will further test the accuracy of the work.

Any unsymmetrical arch with joints situated differently from the case considered can be treated by a like method.

The temperature strains should be treated like those in Fig. 8, which are caused by a thrust along the closing line. Those at right angles to this line vanish as the joints allow motion in this direction. The shearing and tangential stresses can be found as in Fig. 3.

Arches with more than three hinge joints are in unstable equilibrium, and can only be used in an inverted position as suspension bridges. These will be treated subsequently. If the joints, however, possess some stiffness so that they are no longer hinge joints, but are block-work joints, or analogous to such joints, we may still construct arches which are stable within certain limits although the number of joints is indefinitely increased. Such are stone or brick arches. These will also be treated subsequently.

The constructions in Figs. 6, 7, 8, 9, can be tested by a process like that employed in Figs. 2 and 3. In Fig. 2, for instance, we obtained the algebraic sum of the squares of the quantities of the type ss , and showed that such sum vanishes. We can obtain the same result in all cases.

CHAPTER IX.

THE CINCINNATI AND COVINGTON SUSPENSION BRIDGE. (Fig. 10.)

THE main span of this bridge has a length of 1057 feet from center to center of the towers, and the end spans are each 281 feet from the abutment to the center of the tower. The deflection of the cable is 89 feet at a mean temperature, or about $1-11.87$ th of the span. There is a single cable at each side of the bridge. Each of these cables is made up of 5200 No. 9 wires, each wire having a cross-section of $1-60$ th of a square inch and an estimated strength of 1620 lbs. Each of these cables has a diameter of $12\frac{3}{8}$ inches, and an estimated strength of 4212 tons. Each cable rests at the tower upon a saddle of easy curvature, the saddle being supported by 32 rollers which run upon a cast iron bed-plate 8×11 feet, which forms part of the top of the tower. Since the bed-plate is horizontal this method of support ensures the exact perpendicularity of the force

which the cables exert upon the towers, without its being necessary to make the inclination of the cable on both sides of the saddle the same. There is, therefore, no tendency by the cables to overturn the towers, and they need only be proportioned to bear the vertical stresses coming upon them.

As this bridge differs greatly in some respects from other suspension bridges, it seems necessary to describe its peculiarities somewhat minutely.

The roadway and sidewalks make a platform 36 feet wide, extending from abutment to abutment, 1619 feet. It is built of three thicknesses of plank solidly bolted together, in all 8 inches thick. This is strengthened by a double line of rolled I girders, 1630 feet long, running the entire length of the center of the platform. These I girders are arranged one line above the other, and across between them, at distances of 5 feet, run lateral I girders which are suspended from the cable. The upper line of girders is 9 inches deep, (and 30 lbs. per foot); the lower line is 12 inches deep (and 40 lbs. per foot). The lateral girders are 7 inches deep (and 20 lbs. per foot), and are firmly embraced between the double line of longitudinal girders. The girders of this center line are each 30 ft. long, and are spliced together by plates in the hollows of the I, but the holes through which the bolts pass are slots whose length is two or three times the diameter of the bolts. This makes a "slip joint" such as is often used in fastening the ends of the rails on a railroad. The slip joints permit the wooden planking of the roadway to expand and contract from variations of moisture and temperature without interference from the iron girders which are bolted to it.

There is also a line of wrought-iron truss-work about 10 feet deep extending from abutment to abutment on each side of the roadway, consisting of panels of 5 feet each, to each lower joint of which is fastened a lateral girder and a suspender from the cable. This trussing is a lattice, with vertical posts, and ties extending across two panels, and its chords are both made with slip joints every 30 feet.

It is apparent that this whole arrangement of flooring with the girders and

trusses attached to it possesses a very small amount of stiffness, in fact the stiffness is principally that of the flooring itself. It will permit a very large deflection, say 25 feet, up or down from its normal position without injury. Its office is something quite different from that of the ordinary stiffening truss of a suspension bridge. It certainly serves to distribute concentrated loads over short distances, but not to the extent required, if that were the sole means of preserving the cable in a fixed position under the action of moving loads. Its true function is to destroy all vibrations and undulations, and prevent their propagation from point to point by the enormous frictional resistance of these slip joints. When a wave does work against elastic forces, the reaction of those forces returns the wave with nearly its original intensity, but when it does work against friction it is itself destroyed.

The means relied on in this bridge to resist the effect of unbalanced loads is a system of stays extending from the top of the tower in straight lines to those parts of the roadway which would be most deflected by such loads. There are 76 such stays, 19 from the top of each tower. The longest stays extend so far as to leave only 350 feet, *i.e.*, a little over one-third of the span, in the center over which they do not extend. Each stay being a cable $2\frac{1}{4}$ inches in diameter has an estimated strength of 90 tons. They are attached every 15 feet to the roadway at the lower joints of the trussing, and are kept straight by being fastened to the suspenders where they cross them. This system is shown in Fig. 10 in which all the stays for one cable are drawn, together with every third suspender. The suspenders occur every 5 feet throughout the bridge but none are shown in the figure except those attached at the same points as the stays.

These stays must sustain the larger part of any unbalanced load, at the same time producing a thrust in the roadway against either the abutment or tower.

It is really an indeterminate question as to how the load is divided between the stays and trussing; and this the more, because of the manner in which the other extremities of the stays are attached. Of the nineteen stays

carried to the top of one tower, the eight next the tower are fastened to the bed plate under the saddle, and so tend to pull the tower into the river; the remaining eleven are carried over the top of the tower, and rest on a small independent saddle, beside the main saddle, and are eight of them fastened to the middle portion of the side spans as shown in Fig. 10, while the other three are anchored to the abutment.

In view of the indeterminate nature of the problem, it has seemed best to suppose that the stays should be proportioned to bear the whole of any excess of loading of any portion of the bridge, over the uniformly distributed load (which latter is of course borne by the cable itself); and further that the truss really does bear some fraction of the unbalanced load, and that the bending moments have therefore the same relative amounts as if they sustained the entire unbalanced load. This fraction, however, is quite unknown owing to the impossibility of finding any approximate value of the moment of inertia I for the combined wood and iron work of the roadway.

This method of treatment has for our present purpose this advantage, that the construction made use of is the same as that which must be used when there are no stays at all, and the entire bending moments induced by the live loads are borne by the stiffness of the truss alone.

Now in order to determine the tension in any stay, as for instance that in the longest stay leading to the right hand tower, lay off v_1v_2 equal to the greatest unbalanced weight, which under any circumstances is concentrated at its lower extremity. This weight is sustained by the longitudinal resistance of the flooring, and the tension of the stay. The stresses induced in the stay and flooring by the weight, are found by drawing from v_1 and v_2 the lines v_1o and v_2o parallel respectively to the stay and the flooring. Then v_1o is the tension of the stay, and that of the other stays may be found in a similar manner.

It is impossible to determine with the same certainty how the stress ov_2 parallel to the flooring is sustained. It may be sustained entirely by the compression it produces in the part of the flooring between the weight and the tower or the

abutment; or it may be sustained by the tension produced in the flooring at the left of the weight; or the stress ov_2 may be divided in any manner between these two parts of the flooring, so that v_1, v_1' may represent the tension at the left, and ov_2, v_2' the compression at the right of the weight. It appears most probable that the induced stress is borne in the case before us by the compression of the flooring at the right, for the flooring is ill suited to bear tension both from the slip joints of the iron work and the want of other secure longitudinal fastenings; but on the contrary it is well designed to resist compression. The flooring must then be able at the tower to resist the sum of the compressions produced by all the unbalanced weights which can be at once concentrated at the extremities of the nineteen stays.

There is one considerable element of stiffness which has not been taken account of in this treatment of the stays, which serves very materially to diminish the maximum stresses to which they might otherwise be subjected. This is the intrinsic stiffness of the cable itself which is formed of seven equal subsidiary cables formed into a single cable, by placing six of them around the seventh central cable, and enclosing the whole by a substantial wrapping of wire, so that the entire cable having a diameter of $12\frac{1}{2}$ inches, affords a resistance to bending of from one sixth to one half that of a hollow cylinder of the same diameter and equal cross section of metal. Which of these fractions to adopt depends somewhat on the tightness and stiffness of the wrapping.

It is this intrinsic stiffness of the cable which is largely depended upon in the central part of the bridge, between the two longest stays, to resist the distortion caused by unbalanced weights.

As might be foreseen the distortions are actually much greater in the central part of the bridge than elsewhere, though they would have been by far the greater in those parts of the bridge where the stays are, had the stays not been used.

The center of a cable is comparatively stable while it is undergoing quite considerable oscillations, as may be readily seen by a simple experiment with a rope or chain.

Let us now determine the relative

amount of the stresses in the stiffening truss, on the supposition that the actual stresses are some unknown fraction of the stresses which would be induced, if there were no stays, and the truss was the only means of stiffening the cable. We, therefore, have to determine only the total stresses, supposing there are no stays, and then divide each stress obtained by n (at present unknown) to obtain the results required. Let us draw the equilibrium polygon d which is due to a uniform load of depth xy , and which has a deflection bd six times the central deflection of the cable. The loading of the cable is so nearly uniform, that each of the ordinates of the type bd , may be considered with sufficient accuracy to be six times the corresponding ordinate of the cable. Any multiple other than six might have been used with the same facility. In order to cause the polygon to have the required deflection with any assumed pole distance it is necessary to assume the scale of weights in a particular manner, which may be determined easily in several ways. Let us find it thus :

Let W = one of the concentrated weights.

Let D = central deflection of cable.

Let S = span of the bridge

Let M = central bending moment due to the applied weights.

Then, if the pole distance = $\frac{1}{3}S$, $M = \frac{1}{3}S \times 6D = 2SD$, for the moment is the product of the pole distance by the ordinate of the equilibrium polygon. Again, computing the central moment from the applied forces,

$$M = \frac{1}{2} W \times \frac{1}{2} S - 5 W \times \frac{1}{4} S = \frac{3}{2} WS,$$

in which the first term of the right hand member is moment of the resistance of the piers, and the second term is the moment of the concentrated weights applied at their center of gravity.

$$\therefore \frac{3}{2} WS = 2SD \therefore W = \frac{4}{3} D,$$

Hence, if one-third of the span is to represent the pole distance or true horizontal tension of an equilibrium curve having six times the deflection of the cable, each concentrated weight when the span is divided into twelve equal parts, is represented by a length equal to $\frac{4}{3}$ of the deflection of the cable. The

true horizontal tension of the cable will be six times that of the equilibrium polygon, or it will be represented, in the scale used, by a line twice the length of the span. Now taking b as the pole, at distances $bb_4 = bb_4' = \frac{1}{2}S$, lay off $b_4'w_1 = b_4w_1' = \frac{1}{2}W = \frac{2}{3}D$, so that they together represent the weight concentrated at b_4 ; and let $w_1w_2 = W$, represent the weight concentrated at b_2 , etc. Then can the equilibrium polygon d be constructed by making $dd_1 \parallel bw_1$, $d_1d_2 \parallel bw_2$, etc. If $bd = 6D$ the polygon must pass through b_6 and b_6' , which tests the accuracy of the work.

Now to investigate the effect of an unbalanced load covering one-half the span, let us take one half the load on the right half of the span and place it upon its left, so that xz and xb represent the relative intensity of the loading upon the left and right half of the span respectively, the total load being the same as before. If it is desirable to consider that the total load has been increased by the unbalanced load we have simply to change the scale so that the same length of load line as before, (viz, $b_4'w_6 + b_4w_6'$) shall represent the total loading. This will give a new value to the horizontal tension also.

Now let a new equilibrium polygon c be drawn, which is due to the new distribution of the concentrated weights. It is necessary to have the closing line of this polygon c horizontal, and this may be accomplished either, by drawing the polygon in any position and laying off the ordinates of the type bc equal to those in the polygon so drawn, or better as is done in this Figure by laying off in each weight line that part of the total load which is borne by each pier, which is readily computed, as follows. The distance of the center of gravity of the loading divides the span in the ratio of 17 to 27. Hence $\frac{27}{44}$ and $\frac{17}{44}$ of the total load are the resistances of the piers, or since the total load = $11W$, we have $b_4'u_6 = \frac{27}{44}W$ and $b_4'u_6' = \frac{17}{44}W$. Now make u_6 u_5 = the weight concentrated at b_5 , etc., and $b_4'u_2 + b_4'u_1 =$ that at b_1 . Then draw the polygon c .

The polygon c has the same central deflection as the polygon d ; for compute as before,

$$\therefore M = \frac{17}{44}W \times \frac{1}{2}S - \frac{5}{44}W \times \frac{1}{4}S = \frac{3}{44}WS$$

in which the first term of the second member is the moment of the resistance of the right pier, and the second term is the moment of the concentrated weights applied at their center of gravity.

By similar computations we may prove the following equalities;

$$\begin{aligned} d_5c_5 &= d_1c_1 - -d_1'c_1' = -d_5'c_5'; \\ d_4c_4 &= d_2c_2 = -d_2'c_2' = -d_4'c_4'; \\ d_3c_3 &= -d_3'c_3'. \end{aligned}$$

The quantities of the type dc are proportional to the bending moments which the stiffening truss must sustain if it preserves the cable in its original shape, when acted on by an unbalanced load of depth bx , on the supposition that the truss has hinge joints at its ends, and is by them fastened to the piers. For in that case the cable is in the condition of an arch with hinge joints at its ends. The condition which then holds is this:

$$\Sigma(May) = \Sigma(Mcy)$$

or, $\Sigma(M_d - M_c)y = 0 \therefore \Sigma(cdl)y = 0.$

This last is fulfilled as is seen by the above equations, for to every product such as $+b_1d_1 \times d_1c_1$ corresponds another $-b_1'd_1' \times d_1'c_1'$ of the same magnitude but opposite sign.

The polygon c could have been obtained by a second equilibrium polygon in a manner precisely like that used before, but as it appears useful to show the connection between the methods of treating the arch rib which is itself stiff, and the flexible arch or cable, which is stiffened by a separate truss, we have departed from our previously employed method for determining the polygon c , as it is easy to do when both c and d are parabolic.

Now let us compute the bending moment

$$\begin{aligned} &= d_5c_5 \times \frac{1}{3}S = M^c - M^d \\ M^c &= \frac{27}{44}W \times \frac{1}{2}S = \frac{27}{88}WS \\ M^d &= \frac{17}{44}W \times \frac{1}{2}S = \frac{17}{88}WS \\ \therefore M^c - M^d &= \frac{5}{88}WS. \end{aligned}$$

Compute also the bending moment at the vertical through b_4 ,

$$\begin{aligned} M^c &= \frac{27}{44}W \times \frac{1}{6}S - \frac{5}{44}W \times \frac{1}{2}S = WS \\ M^d &= \frac{17}{44}W \times \frac{1}{6}S - W \times \frac{1}{2}S = \frac{5}{44}WS \\ \therefore M^c - M^d &= \frac{1}{44}WS \end{aligned}$$

Similar computations may be made for the remaining points, and this noteworthy result will be found true, that the bending moments induced in the stiffening truss by the assumed loading, are the same as would have been induced by a positive loading on the left of a depth yz , and a negative loading on the right of an equal depth yb . For compute the moments due to such loading at the points b_5 and b_4 .

The resistance of the pier due to such loading = $\frac{5}{4} W$

$$\therefore M_5 = \frac{5}{4} W \times \frac{1}{2} S = \frac{5}{8} WS$$

and

$$M_4 = \frac{5}{4} W \times \frac{1}{6} S - \frac{1}{2} W \times \frac{1}{2} S = \frac{1}{6} WS, \text{ etc.}$$

We arrive then at this conception of the stresses to which the stiffening truss is subjected, viz:—the truss is loaded with the applied weights acting downward, and is drawn upward by a uniformly distributed negative loading, whose total amount is equal to the positive loading, so that the load actually applied at any point may be considered to be the algebraic sum of the two loads of different signs which are there applied. This conception might have been derived at once from a consideration of the fact that the cable can sustain only a uniform load, if it is to retain its shape; but it appears useful in several regards to show the numerical agreement of this statement with Prop. IV of which in fact it is a particular case. It is unnecessary to make a general proof of this agreement, but instead we will now state a proposition respecting stiffening trusses, the truth of which is sufficiently evident from considerations previously adduced.

Prop. VI. The stresses induced in the stiffening truss of a flexible cable or arch, by any loading, is the same as that which would be induced in it by the application to it of a combined positive and negative loading distributed in the following manner, viz: the positive loading is the actual loading, and the negative loading is equal numerically to the positive loading, but is so distributed as to cause no bending moments in the cable or arch, *i.e.*, the cable or arch is the equilibrium polygon for this negative loading.

By flexible cable or arch is meant one which has hinge joints at the points where it supports the stiffening truss. It need not actually have hinge joints at these points: the condition is sufficiently fulfilled if it is considerably more flexible than the truss which it supports.

The truth of Prop. VI has been recognized by previous writers upon this subject in the particular case of the parabolic suspension cable, and it has been erroneously applied to the determination of the bending moments in the arch rib in general. It is inaccurate for this purpose in two particulars, inasmuch as in the first place the arch to which it is applied is not parabolic, though the negative loading due to it is assumed to be uniform, and in the second place the horizontal thrust is not the same for the different kinds of arch rib, while this assumes the same thrust for all, viz: that arising from a flexible arch or one with three or more joints.

A similar proposition has been introduced into a recent publication on this subject*, but in that work the truss stiffens a simple parabolic cable, and the truss is not supposed to be fastened to the piers, so that it may rise from either pier whenever its resistance becomes negative. As this should not be permitted in a practical construction the case will not be discussed. In accordance with Prop. VI let us determine anew the bending moments due to an unbalanced load on the left of an intensity denoted by bz . As before seen this produces the same effect as a positive loading of an intensity $yz = fm = \frac{1}{2}bz$ on the left, and a negative loading of an intensity $yb = fn = \frac{1}{2}bz$. Now using g as a pole with a pole distance of $gf_2 =$ one third of the span lay off the concentrated weight $p_1 p_2 =$ that applied at b_1 , etc., on the same scale as the weights were laid off in the previous construction, and in such a position that g is opposite the middle of the total load, which will cause the closing line to be horizontal. Then draw the equilibrium polygon a due to these weights. The ordinates of the type af are by Prop. VI proportional to the bending moments induced in the stiffening truss by the unbalanced load when the truss is simply fastened to the

* Graphical Statics, A. J. Du Bois, p. 329, published by John Wiley & Son, New York.

piers at the ends, and, as we have seen, each of the quantities af' is identical with the corresponding quantity cd .

If the stiffening truss is fixed horizontally at its ends a closing line hh' must be drawn in such a position that $\Sigma(M) = 0$, and as it is evident that it must divide the equilibrium polygon symmetrically it passes through f' its central point.

As stated in a previous article, the maximum bending moments at certain points of the span are caused when the unbalanced load covers somewhat more than half of the span. In the case of a parabolic cable or arch the maximum maximum bending moment is caused when this load extends over two-thirds of the span, as is proved by Rankine in his Applied Mechanics by an analytic process. Let the load extend then over all except the right hand third of the span with an intensity represented by $bz = q_3 q_4'$. Then if $f_2' q_3 = \frac{1}{2} f_2' q_4'$, the truss may by Prop. VI be considered to sustain a positive load of the intensity $f_2' q_3$ on the left of b_2' , and a negative load of the intensity $f_2' q_4'$ on the right of b_2' . Using g' as the pole and the same pole distance as before, lay off the weight $q_3 q_4'$ concentrated at b_3 , etc., so that g' is opposite the middle of the weight line. We thus obtain the equilibrium polygon e , in which the ordinates of the type ef are proportional to the bending moments of the truss under the assumed loading, when its ends are simply fastened to the piers.

Now bd was the ordinate of an equilibrium polygon having the same horizontal tension, and under a load of the same intensity covering the entire span. It will be found that $bd = \frac{27}{4} f_2' e_2$, which may be stated thus:—the greatest bending moment induced in the stiffening truss, by an unbalanced load of uniform intensity is four twenty-sevenths of that produced in a simple truss under a load of the same intensity covering the entire span. This result was obtained by Rankine analytically. If the truss is fixed horizontally at its ends, we must draw a closing line kk' , which fulfills the conditions before used for the straight girder fixed at the ends, as discussed previously in connection with the St. Louis Arch. By the construction of a second equilibrium polygon, as there given, we find

the position of kk' ; then the ordinates ke will be proportional to the bending moments of the stiffening truss.

The shearing stress in the truss is obtained from the loading which causes the bending moment, in the same manner as that in any simple truss. The horizontal tension in the cable, is the same whenever the total load on the span is the same, and is not changed by any alteration in the distribution of the loading, which fact is evident from Prop. VI. The maximum tension of the cable is found when the live load extends over the entire span, and is to be obtained from a force polygon which gives for its equilibrium polygon the curve of the cable itself, as would be done by using the weights w, w_2 , etc., and a pole distance of six times $bb_4 =$ twice the span.

The temperature strains of a stiffening truss of a suspension bridge are more severe than those of the truss stiffening an arch, because the total elongation of the cable in the side spans as well in the main span, is transmitted to the main span and produces a deflection at its center. This is one reason why stays furnish a method of bracing, particularly applicable to suspension bridges. But supposing that the truss bears part of the bending moment due to the elongation of the cable, it is evident that when the truss is simply fastened to the piers, the bending moments so induced are proportional to the ordinates of the type bd , for by the elongation of the cable, it transfers part of its uniformly distributed weight to the truss.

That load which the cable still sustains, is uniformly distributed, if the cable still remains parabolic, therefore that transferred to the truss is uniformly distributed.

When the truss is fixed horizontally at the piers, the closing line of the curve d must be changed so that $\Sigma(M) = 0$, and the bending moments induced by variations of temperature, will be proportional to the ordinates between the curve d and this new closing line.

It remains only to discuss the stability of the towers and anchorage abutments. The horizontal force tending to overturn the piers comes from a few stays only, as was previously stated, and is of such small amount that it need not be considered.

The weight of the abutment in the case before us is almost exactly the same as the ultimate strength of the cable. Suppose that $st=sv$ are the lines representing these quantities in their position relatively to the abutment. Since their resultant sv intersects the base beyond the face of the abutment, the abutment would tip over before the cable could be torn asunder. And since the angle vsr is greater than the angle of friction between the abutment and the ground it stands on, the abutment if standing on the surface of the ground, would slide before the cable could be torn asunder.

The smallest value which the factor of safety for the cable assumes under a maximum loading is computed to be six. Take $st'=\frac{1}{6}st$ as the greatest tension ever induced in the cable, then sr' the resultant of sv and st' cuts the base so far within the face that it is apparent that the abutment has sufficient stability against overturning, and the angle vsr' is so much smaller than the least value of the angle of friction between the abutment and the earth under it, that the abutment would not be near the point of sliding even if it stood on the surface of the ground. It should be noticed that all the suspenders in the side span assist in reducing the tension of the cable as we approach the abutment, and conduce by so much to its stability. Also the thrust of the roadway may assist the stability of the abutment, both with respect to overturning and sliding.

CHAPTER X.

THE CONTINUOUS GIRDER WITH VARIABLE CROSS-SECTION.

In the foregoing chapters the discussion of arches of various kinds has been shown to be dependent upon that of the straight girder; but as no graphical discussion has, up to the present time, been published which treats the girder having a variable cross-section and moment of inertia, our discussion has been limited to the case of arches with a constant moment of inertia.

Certain remarks were made, however, in the first chapter tending to show the close approximation of the results in case of a constant moment of inertia to those obtained when the moment of inertia is variable. We, in this chapter,

propose a new solution of the continuous girder in the most general case of variable moment of inertia, the girder resting on piers having any different heights consistent with the limits of elasticity of the girder. This solution will verify the remarks made, and enable us easily to see the manner in which the variation of the moment of inertia affects the distribution of the bending moments, and by means of it the arch rib with variable moment of inertia can be treated directly.

Besides the importance of the continuous girder in case it constitutes the entire bridge by itself, we may remark that the continuous girder is peculiarly suited to serve as the stiffening truss of any arched bridge of several spans in which the arches are flexible. Indeed, it is the conviction of the writer that the stiff arch rib adopted in the construction of the St. Louis Bridge was a costly mistake, and that, if a metal arch was desirable, a flexible arch rib with stiffening truss was far cheaper and in every way preferable.

Let us write the equation of deflections in the form

$$mD \cdot \frac{EI_0}{mn^2n'} = \Sigma \left(\frac{Mi}{nn'} \cdot \frac{x}{n} \right)$$

in which n is the number by which any horizontal dimension of the girder must be divided to obtain the corresponding dimension in the drawing, n' is the divisor by which force must be divided to obtain the length by which it is to be represented in the drawing, m is an arbitrary divisor which enables us to use such a pole distance for the second equilibrium polygon as may be most convenient, I_0 is the moment of inertia of the girder at any particular cross section assumed as a standard with which the values of I at other cross sections are compared, and $i=I_0 \div I$ is the ratio of I_0 (the standard moment of inertia), to I (that at any other cross-section). For the purpose of demonstrating the general properties of girders, the equation need not be encumbered with the coefficients mnn' , but for purposes of explaining the graphical construction they are very useful, and can be at once introduced into the equation when needed.

In the equation

$$D \cdot EI_0 = \Sigma_a^o (Mix)$$

the quantity D is the deflection of any point O of the girder below the tangent at the point a where the summation begins, and M is the actual bending moment at any point between O and a . These moments M at any point consist in general of three quantities, represented in the construction by the positive ordinate of the equilibrium polygon due to the weights, and by the two negative ordinates of the triangles into which we have divided the negative moment area. If we distinguish these components of M by letting M_0 represent that due to the weights, while M_1 and M_2 represent the components due to the left and right negative areas respectively, the equation of deflections becomes

$$D \cdot EI_0 = \sum_a^o (M_0 ix) - \sum_a^o (M_1 ix) - \sum_a^o (M_2 ix)$$

Now let us take O at a pier at one end of a span and extend the summation over the entire span.

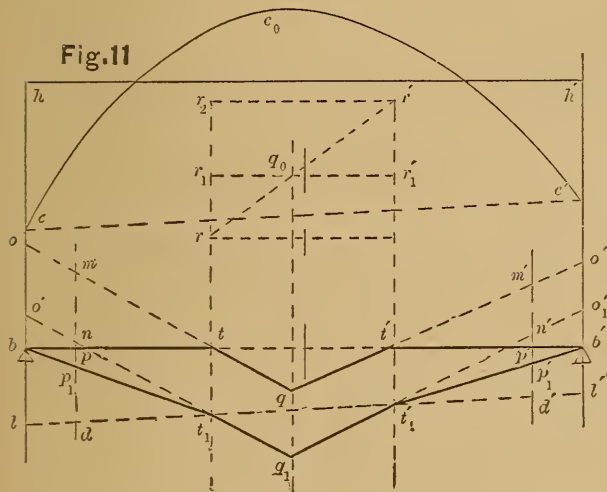

If the piers are b and b' as in Fig. 11, let us suppose that O coincides with b and a with b' ; also suppose for the instant that I is constant, so that $i=1$ at all points of the girder. Then we have

$$D_b \cdot EI = \bar{x}_3 \sum_{b'}^b (M_0) - \bar{x}_1 \sum_{b'}^b (M_1) - \bar{x}_2 \sum_{b'}^b (M_2)$$

in which D_b is the deflection of b below the tangent at b' , \bar{x}_3 is the distance of the center of gravity of the moment area due to the applied weights from b , while \bar{x}_1 and \bar{x}_2 are the distances of the centers of gravity of the negative areas from b . In Fig. 11 let cc_0c' be the positive area due to the weights and repre-

senting $\sum_{b'}^b (M_0)$, while $\sum_{b'}^b (M_1)$ and $\sum_{b'}^b (M_2)$ are represented by hcc' and $hh'c'$ respectively. Let the center of gravity of cc_0c' be in qq_0 , while the centers of the two negative areas are in tr and $t'r'$. Let the height of a triangle on some assumed base, and equivalent in area to cc_0c' , be rr_2 , then by a process like that in Fig. 2 it is evident that rr_1 and r_1r_2 are the heights of the right and left negative triangles, having the assumed base, on the supposition that the girder is fixed horizontally over the piers.

Now introducing the constants mnn' into the last equation and into the equation before that, the relation of the quantities is such that if the moments be applied as weights at their centers of gravity with the pole distance $pt = EI \div mnn'$, the equilibrium polygon so obtained will be tangent at the piers to the exaggerated deflection curve obtained when the distributed moments are used as weights; and the deflection at the pier b from the tangent at b' will be the same as that of this exaggerated deflection curve, and vice versa.

Let $pm = r_1r_2$, $p'm' = rr_1$ and $pt = p't$, then t and t' constitute the pole, pm and $p'm'$ the negative loads, and $pm + p'm'$ the positive load. Then is $btqt'b'$ the equilibrium polygon for these loads. The deflection of b below $b't'$ vanishes as it should in case the girder is fixed horizontally over the pier.

Now let the direction of the tangents at the piers be changed so that the tangents to the exaggerated deflection curve assume the directions bt_1 and $b't_1'$. Then the load line and force polygon assume a new position, such that t_1 and t_1' form the pole, and $d'n = pm$ and $d'n' = p'm'$ comprise the positive load while np_1 and $n'p_1'$ are the new negative loads which will cause the equilibrium polygon $bt_1q_1t_1'b'$, which is due to them, to have its sides bt_1 and $b't_1'$ in the directions assumed.

There are several relations of quantities in this figure to which we wish to direct attention. It is evident, in case I is not constant, that from the area cc_0c' whose ordinates are proportional to M_0 , the actual bending moments due to the weights, another area whose ordinates are proportional to

M_0i , the effective bending moments, can be obtained by simple multiplication, since i is known at every point of the girder. Moreover, the vertical through the center of gravity of this positive effective moment area can be as readily found as that through the actual positive moment area. Call this vertical "the positive center vertical." Again, the negative moment areas proportional to M_1i and M_2i can be found from the triangular areas proportional to M_1 and M_2 by simple multiplication, and if we proceed to find the verticals through their centers of gravity we shall obtain the same verticals whatever be the magnitude of the negative triangular areas, since their vertical ordinates are all changed in the same ratio by assuming the negative areas differently. Let us call these verticals the "left" and "right" verticals of the span. In case $i=1$, as in Fig. 11, the left and right verticals divide the span at the one-third points. This matter will be treated more fully in connection with Fig. 13.

Again, let us call the line t_1t_1' "the third closing line." It is seen that, whatever may be the various positions of the tangent bt_1 , the ordinate dn , between the third closing line and t_1q_1 prolonged, is invariable; for the triangle $t_1q_1t_1'$ is invariable, being dependent on the positive load and pole distance alone. By similarity of triangles it then follows that the ordinate, such as lo' , on any assumed vertical continues invariable; and when there is no negative load at t_1 , then bt_1q_1 becomes straight, o' coincides with b and n with p_1 . Similar relations hold at the right of q_1 . The quantity dp_1 is of the nature of a correction to be subtracted from the negative moment when the girder is fixed horizontally at the piers in order to find the negative moment when the tangent assumes a new position, for $np_1 = dn - dp_1$. The negative moments can consequently be found from the third closing line and the tangents at the piers; while the remaining lines q_1t_1 and $q_1't_1'$ will test the correctness of the work. Before applying these properties of the deflection polygon and its third closing line to a continuous girder, it is necessary to prove a geometrical theorem from Fig. 12.

Let the variable triangle xyz be such that the side xz always passes through

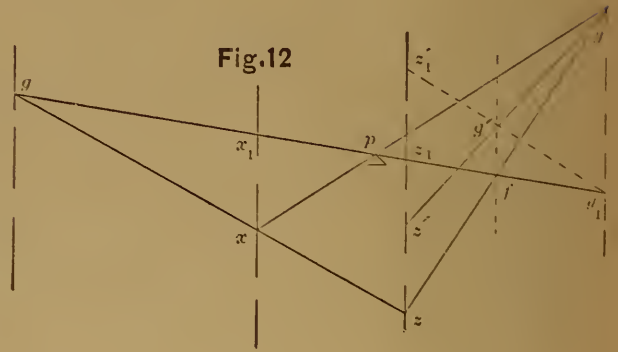

the fixed point g , the side xy always passes through the fixed point p , and the vertices xyz are always in the verticals through those points; then by the properties of homologous triangles the side yz also has a fixed point f in the straight line gp . Furthermore, if there is a point z' in the vertical through z , and in all positions of z it is at the same constant distance from z , then on the line yz' there is a fixed point g' where the vertical through f intersects yz' ; for, if z' maintains its distance zz' invariable, then must any other point as g' remain constantly at the same vertical distance from f , as appears from similarity of triangles. But as f is fixed g' is also. When, for instance, the triangle xyz assumes the position $x_1y_1z_1$, then z' moves to z'_1 .

Let us now apply the foregoing to the discussion of a continuous girder over three piers $p''pp'$ as shown in Fig. 13, in which the lengths of the spans have the ratio to each other of 2 to 3. Divide the total length of the girder into such a number of equal parts or panels, say 15, that one division shall fall at the intermediate pier, and let the number of lines in any panel of the type aa represent its relative moment of inertia. Assume the moment of inertia where there are three lines, as at a, a_4 , etc., as the standard or I_0 , then $i=1$ at $a, i=\frac{3}{2}$ at $a_2, i=\frac{3}{4}$ at a_6 , etc.

Let the polygons c and c' be those due to the weights in the left and right spans respectively. Then the ordinates of the type bc are proportional to M_0 in the left span. The figure $bc_1c_1''c_2''c_3''c_3c_4c_4c_5''b_0$ is the positive effective moment area in the left span, and its ordinates are proportional to M_0i . Its center of gravity has been found, by an equilibrium

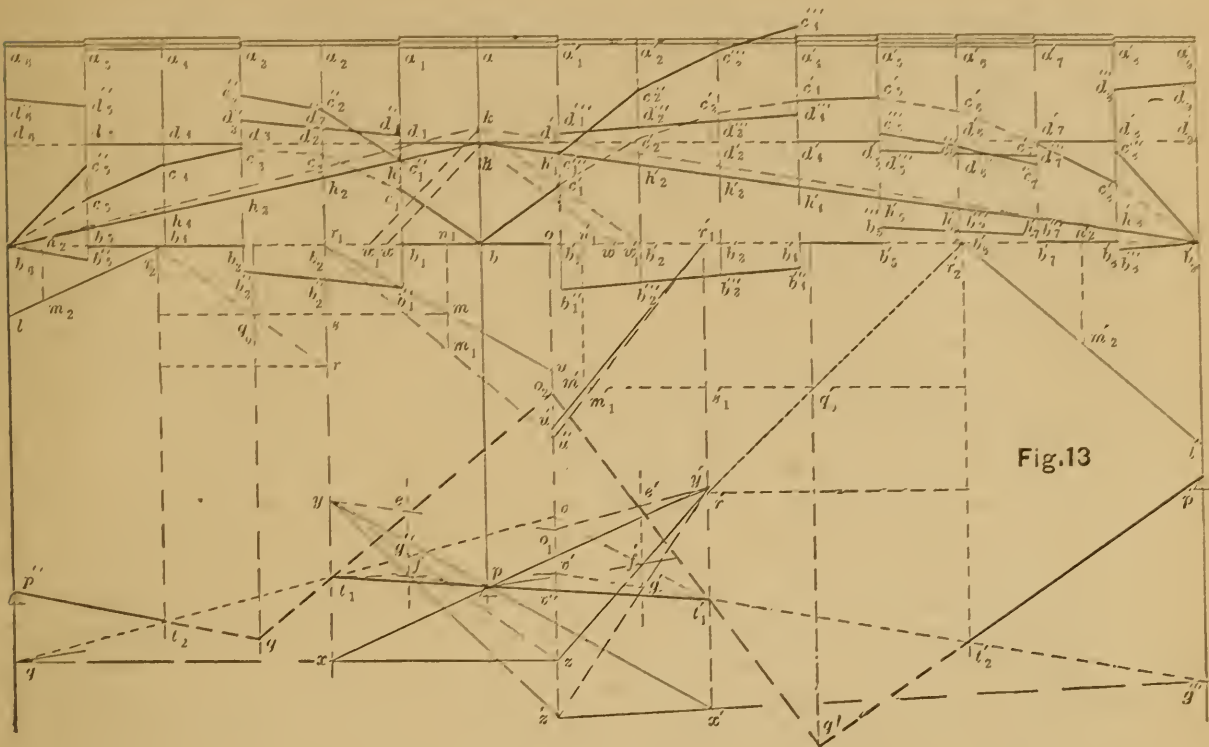

Fig. 13

polygon not drawn, to lie in the positive center vertical qq_0 . A similar positive effective moment area on the right has its center of gravity in the positive center vertical $q'q'_0$.

Now assume any negative area, as that included between the lines b and d , and draw the lines hb_0 and hb'_0 , dividing the negative area in each span into right and left triangular areas. Let the quantities of the type hb be proportional to M_1 , hd to M_2 , $h'b'$ to M'_1 , etc., then the ordinates of $bb_1b_1''b_2''b_3''b_3b_4b_5''b_6h$ are proportional to M_1i , and the center of gravity of this area has been found to lie in the right negative vertical t_1r_1 . Similarly, the left negative vertical containing the center of gravity of the left negative effective moments, is t_2r_2 . In the right span $t_1'r_1'$ and $t_2'r_2'$ are the left and right verticals. As before stated, these verticals would not be changed in position by changing the position in any manner whatever of the line d by which the negative moments were assumed, for such change of position would change all the ordinates in the same ratio.

Let us find also the vertical containing the center of gravity of the effective moment area, corresponding to the actual moment area $b_0hb'_0$. It is found by a polygon not drawn to be vo . Call vo "the negative center vertical." It is unchanged by moving the line d . If a

polygon be drawn due to the effective moments as loads, two of its sides must intersect on vo , because it contains the center of gravity of contiguous loads. Now let rr_1 represent $\Sigma(M_0i)$:—it is in fact one eighth of the sum of the ordinates $b_1c_1 + b_1c_1''$, etc., and hence is the height of a triangle having a base $=\frac{4}{3}bb_0$, and an area equal to the effective moment area in the left span. Also $r'r_1'$ is the height of a triangle having the same base, and an area equal to the effective moment area in the right span.

As previously explained, sr_1 is the amount of the right negative effective moment area in the left span, measured in the same manner, while sr is that on the left when the girder is fixed horizontally at the piers. We obtain $s'r_1'$ and $s'r'$ in the right span, in a similar manner. Now assume the arbitrary divisor $m=1$, and take the pole distance $r_1n_1 = EI_0 \div n^2n'$. Then as seen previously, if $mn_1 = sr_1$, ou is the constant intercept on the negative center vertical, between the third closing line in the left span, and a side of the type qt . Also ou' is a similar constant intercept on this vertical due to the right span. Make $r_2n_2 = r_1n_1$ and $n_2m_2 = sr$, then lv_0 is a similar invariable intercept; as is $l'b'_0$, which is obtained in a similar manner.

Now the negative center vertical ov was obtained from the triangle $b_0hb'_0$, i.e.

on the supposition that the actual moment over the pier is the same whether it be determined from the left or right of the pier. It is evident that while the girder is fixed horizontally at the intermediate pier, the moment at that pier is generally different on the two sides, at points infinitesimally near to it, but that when the constraint is removed an equalization takes place.

Since ou and ou' are derived from the positive effective moments, it appears that when the tangent at p is in such a position that the two third closing lines intercept a distance uu' on ov and the two lines of the type qt when prolonged intersect on ov , the moments over the pier will have become equalized.

We propose to determine the position of the tangent at p which will cause this to be true, by finding the proper position of the third closing lines in the two spans.

Move the invariable intercepts to a more convenient position, by making $o_1z = ou$, and $o_1z' = ou'$. Now by making the arbitrary divisor $m = 1$, as we did, the ordinates of the deflection polygon became simply D , i.e., they are of the same size in the drawing as in the girder, hence the difference of level of p'' , p and p' must be made of the actual size. By changing m this can be increased or diminished at will.

Now we propose to determine two fixed points g and g'' , through which the third closing line in the left span must pass, and similarly g''' and g' on the right.

If the girder is free at p'' then as shown in connection with Fig. 11, the third closing line must pass through g , if $gp'' = lb_6$. Draw gz as a tentative position of the third closing line, and complete the triangle $xy'z$ as in Fig. 12.

Then is xy' the tentative position of the tangent at p , and since the third closing line in the right span must pass through y' , and make an intercept on the negative center vertical equal to uu' , then $z'y'$ is its corresponding tentative position. But wherever gz may be drawn, every line making an intercept $= uu'$ and intersecting $t_1'r_1'$ in such a manner that the tangent passes through p must pass through the fixed point g' , found as described in Fig. 12. Therefore the third closing line in the right span passes through g' . Similarly, if

there were more spans still at the right of these, we should use g' for the determination of another fixed point, as we have used g to determine it.

Now find g''' and g'' precisely as g and g' have been found, and draw the third closing lines t_1t_2 and $t_1't_2'$. If t_1t_1' passes through p the construction is accurate. Make $uu'' = vv''$, then is n_1m_1 the negative effective moment at the left, and $n_1'm_1'$ that at the right of the pier.

Let bw be the effective moment area corresponding to the triangle hbb_6 , and measured in the same manner as the positive area was, by taking one eighth of its ordinates, and let $bw_1 = n_1m_1$; then as the effective moment bw is to the actual moment bh corresponding to it, so is the effective moment bw_1 or n_1m_1 to the actual moment b_k corresponding to it. The same moment b_k is also found from $n_1'm_1'$, by an analogous construction at the right of b , which tests the accuracy of the work.

Several other tests remain which we will briefly mention.

Prolong $p''t_2$ to q , and $p't_2'$ to q' , then qt_1 and $q't_1'$ must intersect on the negative center vertical at o_2 so that $o_2v'' = ou''$. Also vv' must be equal to uu' . Again t_1v' passes through f , and $t_1'v$ through f' . Also yo_1 intersects qo_2 on the fixed vertical fg'' at e , and $y'o_1$ intersects $q'o_2$ on the fixed vertical $f'g'$ at e' . That these must be so is evident from a consideration of what occurs during a supposed revolution of the tangent t_1t_1' , to the position xy' .

Now having determined the moment b_k over the pier, kb_6 and kb_6' are the true closing lines of the moment polygons c and c' . Call these closing lines k , then the ordinates of the type kc will represent the bending moments at different points of the girder. The points of the contra flexure are at the points where the closing lines intersect the polygons c and c' . The directions of the closing lines will permit at once the determination of the resistances at the piers and the shearing stresses at any point.

The particular difference between the construction in case of constant and of variable moment of inertia, is seen to be in the positions of the center verticals positive and negative, and the right and left verticals.

The small change in their position due to the variation in the moment of inertia, is the justification of the remarks previously made respecting the close approximation of the two cases.

It is seen that the process here developed can be applied with equal facility to a girder with any number of spans. Also if the moment of inertia varies continuously instead of suddenly, as assumed in Fig. 13, the panels can be taken short enough to approximate with any required degree of accuracy to this case.

CHAPTER XI.

THE THEOREM OF THREE MOMENTS.

The preceding construction has been in reality founded on the theorem of three moments, but when the equation expressing that theorem is written in the usual manner, the relationship is difficult to see. Indeed the equation as given by Weyrauch* for the girder having a variable moment of inertia, is of so complicated a nature that it may be thought hopeless to attempt to associate mechanical ideas with the terms of the equation, in any clearly defined relationship. We propose to derive and express the equation in a novel manner, which will at once be easy to understand, and not difficult of interpretation in connection with the preceding construction.

Let us assume the general equation of deflections in the form.

$$D = \Sigma(Mx \div EI), \text{ or } D \cdot EI_0 = \Sigma(Mix) \tag{7}$$

in which I is the variable moment of inertia, I_0 some particular value of I assumed as the standard of comparison, $i = I_0 \div I$, and x is measured horizontally from the point as origin, where the deflection D is taken to the point of application of the actual bending moment M . The quantity Mi is called the effective bending moment, and the deflection D is the length of the perpendicular from the origin to the line tangent to the deflection curve at point to which the summation is extended.

Now consider two contiguous spans of a continuous girder of several spans, and let acb denote the piers, c being the intermediate pier. Let the span $ac = l$ and $bc = l'$. Take the origin at a and

extend the summation to c , calling the deflection at a , D_a . When the origin is at b and the summation extends to c , let the deflection be D_b . Let also y_a, y_b and y_c be the heights of a, b and c respectively above some datum level. Then, as may be readily seen,

$$D_a = y_a - y_c - lt_c, \\ D_b = y_b - y_c - l't'_c,$$

if t_c is the tangent of the acute angle at c on the side towards a between the tangent line of the deflection curve at c and the horizontal, and t'_c is the tangent of the corresponding acute angle on the side of c towards b .

Now if we consider equation (7) to refer to the span l , the moment M may be taken to be made up of three parts, viz:— M_0 caused by the weights on the girder, M_1 dependent on the moment M_c at c , and M_2 dependent on the moment M_a at a . The moments in the span l' may be resolved in a similar manner. We may then write the equations of deflections in the two spans when the summation extends over each entire span as follows:

$$EI_0(y_a - y_c - lt_c) = \Sigma_c^a(M_0ix) - \Sigma_c^a(M_1ix) - \Sigma_c^a(M_2ix) \dots \dots \dots \tag{8}$$

$$EI_0(y_b - y_c - l't'_c) = \Sigma_c^b(M'_0i'x') - \Sigma_c^b(M'_1i'x') - \Sigma_c^b(M'_2i'x') \tag{9}$$

in which x is measured from a , and x' from b towards c . Now if the girder is originally straight, $t_c = -t'_c$, hence we can combine these two equations so as to eliminate t_c and t'_c , and the resulting equation will express a relationship between the heights of the piers, the bending moments (positive and negative), their points of application and the moments of inertia; of which quantities the negative bending moments are alone unknown. The equation we should thus obtain would be the general equation of which the ordinary expression of the theorem of three moments is a particular case. Before we write this general equation it is desirable to introduce certain modifications of form which do not diminish its generality. Suppose that

$$\bar{x}_1 \Sigma_c^a(M_1i) = \Sigma_c^a(M_1ix)$$

then is \bar{x}_1 the distance from a to the center of gravity of the negative effective

* Allgemeine Theorie und Berechnung der Continuirlichen und Einfachen Trager. Jakob I. Weyrauch. Leipzig 1873.

moment area next to c . As was shown in connection with Fig. 13, the position of this center of gravity is independent of the magnitude of M_1 or M_c and may be found from the equation,

$$\bar{x}_1 = \frac{\int_c^a ix^2 dx}{\int_c^a ix dx} \dots (10)$$

for M_1 is proportional to x . Similarly it may be shown that

$$\bar{x}_2 = \frac{\int_c^a i(l-x)x dx}{\int_c^a i(l-x) dx} \dots (11)$$

is the distance of the center of gravity of the negative effective moment area next to a .

Again, suppose that

$$i_1 \Sigma_c^a (M_1) = \Sigma_c^a (Mi)$$

then is i_1 an average value of i for the negative effective moment area next to c , which is likewise independent of the magnitude of M_1 , as appears from reasoning like that just adduced respecting \bar{x}_1 . Hence i_1 may be found from the equation

$$i_1 = \frac{\int_c^a ix dx}{\int_c^a x dx} \dots (12)$$

Similarly it may be shown that

$$i_2 = \frac{\int_c^a i(l-x) dx}{\int_c^a (l-x) dx} \dots (13)$$

in which i_2 is the average value of i for the negative effective moment area next to a .

The integrals in equations (10), (11), (12), (13), and in others like them referring to the span l' , which contain i must be integrated differently, in case i is discontinuous, as it usually is in a truss, from the case where i varies continuously. When i is discontinuous the integral extending from c to a must be separated into the sum of several integrals, each of which must extend over that portion of the span l in which i varies continuously.

Furthermore we have

$$\Sigma_c^a (M_1) = \frac{1}{2} M_c l \dots (14)$$

since each member of this equation rep-

resents the negative actual moment area next to c in the span l .

Similarly, we have the equations

$$\Sigma_c^a (M_2) = \frac{1}{2} M_{al} l, \quad \Sigma_c^b (M_1') = \frac{1}{2} M_c l',$$

$$\Sigma_c^b (M_2' l') = \frac{1}{2} M_b l'.$$

If there is no constraint at the pier then must $M_c = M_c'$.

Now making the substitutions in equations (8) and (9), which have been indicated in the developments just completed, and then eliminating t_c and t_c' ,

$$EI_0 \left\{ \frac{y_a - y_c}{l} + \frac{y_b - y_c}{l'} \right\} - \frac{\bar{x}_0 i_0}{l} \Sigma_c^a (M_0) - \frac{\bar{x}_0' i_0'}{l'} \Sigma_c^b (M_0') = \frac{1}{2} [M_a \bar{x}_2 i_2 + M_c (\bar{x}_1 i_1 + \bar{x}_1' i_1') + M_b \bar{x}_2' i_2'] \dots (15)$$

in which \bar{x}_0 is the distance from a of the center of gravity of the positive effective moment area due to the weights in the span l , and \bar{x}_0' is a similar distance from b in the span l' , while i_0 and i_0' are average values of i for these areas derived from the equations in each span,

$$i_0 = \Sigma (M_0 i) \div \Sigma (M_0).$$

It may frequently be best to leave the expressions containing the positive moments in their original form as expressed in equations (8) and (9).

Equation (15) expresses the theorem of three moments in its most general form.

Let us now derive from equation (15), the ordinary equation expressing the theorem of three moments, for a girder having a constant cross section. In this case $i=1$, and we wish to find the value of the term $\Sigma (M_0 x)$ in each span. Let M_0 be caused by several weights P applied at distances z from a , then the moment due to a single weight P at its point of application is

$$M_z = Pz(l-z) \div l,$$

which may be taken as the height of the triangular moment area whose base is l which is caused by P . This triangle whose area is $\frac{1}{2} M_z l$ is the component of $\Sigma (M_0)$ due to P and can be applied as a concentrated bending moment at its center of gravity at a distance x from a .

Now $x = \frac{1}{3}(l+z)$, and taking all the weights P at once

$$\Sigma^a (M_0 x) = \frac{1}{6} \Sigma_c^a [P(l^2 - z^2)z].$$

Also in equation (15) we have in this case

$$\begin{aligned} \bar{x}_1 &= \frac{1}{3}l, \quad \bar{x}_2 = \frac{2}{3}l, \quad \bar{x}'_1 = \frac{1}{3}l', \quad \bar{x}'_2 = \frac{2}{3}l' \\ \therefore 6EI &\left\{ \frac{y_a - y_c}{l} + \frac{y_b - y_c}{l'} \right\} \\ &- \frac{1}{l} \sum_c^a [P(l^2 - z^2)z] - \frac{1}{l'} \sum_c^b [P'(l'^2 - z'^2)z'] \\ &= M_a l + 2M_c (l + l') + M_b l' \quad . \quad (16) \end{aligned}$$

Equation (16) then expresses the theorem of three moments for a girder having a constant moment of inertia I , and deflected by weights applied in the span l at distances z from a , and also by weights in the span l' at distances z' from b .

Let us also take the particular case of equation (15) when the moment of inertia is invariable and the piers on a level; then $i=1$, and if we let A_0 and A'_0 be the positive moment areas due to the weights we have

$$6 \left\{ \frac{1}{l} A_0 \bar{x}_0 + \frac{1}{l'} A'_0 \bar{x}'_0 \right\} = M_a l + 2M_c (l + l') + M_b l' \quad . \quad (17)$$

This form of the equation of three moments was first given by Greene.*

The advantage to be derived in discussing this theorem in terms of the bending moments, instead of the applied weights is evident both in the analytical and the graphical treatment. The extreme complexity of the ordinary formulae arises from their being obtained in terms of the weights.

In order to complete the analytic solution of the continuous girder in the general case of equation (15), it is only necessary to use the well known equations,

$$M = M_c + S_c z_0 - \Sigma_c^o (Pz_0) \quad . \quad (18)$$

$$S_c = \frac{1}{l} [M_a - M_c + \Sigma_c^a (Pz)] \quad . \quad (19)$$

$$S'_c = \frac{1}{l'} [M_b - M_c + \Sigma_c^b (Pz')] \quad . \quad (20)$$

$$R_c = S_c + S'_c \quad . \quad . \quad . \quad (21)$$

$$S = S_c - \Sigma_c^o (P) \quad . \quad . \quad . \quad (22)$$

In (18) M is the bending moment at any point O in the span l , S_c is the shear at c due to the weights in the span l , and z_0 is the distance from O towards c of the applied forces P and S_c in the segment Oc .

Equation (19) is derived from (18) by taking O at a , and (20) is obtained similarly in the span l' . R_c is the reaction of the pier at c . S is the shear at O in the span l . These equations also complete the solution of the cases treated in (16) and (17).

CHAPTER XII.

THE FLEXIBLE ARCH RIB AND STIFFENING TRUSS.

Whenever the moment of inertia of an arch rib is so small, that it cannot afford a sufficient resistance to hold in equilibrium the bending moments due to the weights, it may be termed a flexible rib.

It must have a sufficient cross section to resist the compression directly along the rib, but needs to be stiffened by a truss, which will most conveniently be made straight and horizontal. The rib may have a large number of hinge joints which must be rigidly connected with the truss, usually by vertical parts. It is then perfectly flexible.

If, however, the rib be continuous without joints, or have blockwork joints, it may nevertheless be treated as if perfectly flexible, as this supposition will be approximately correct and on the side of safety, for the bending moments induced in the truss will be very nearly as great as if the rib were perfectly flexible, in case the same weight would cause a much greater deflection in the rib than in the truss. It will be sufficient to describe the construction for the flexible rib without a figure, as the construction can afford no difficulties after the constructions already given have been mastered.

Lay off on some assumed scale the applied weights as a load line, and let us call this vertical load line ww' . Divide the span into some convenient number of equal parts by verticals, which will divide the curve a of the rib into segments. From some point b as a pole draw a pencil of rays parallel to the segments of a , and across this pencil draw a vertical line uu' , at such a distance from b that the distance uu' between the extreme rays of the pencil is equal to ww' . Then the segments of uu' made by the rays of the pencil are the loads which the arch rib would sus-

* Graphical Method for the Analysis of Bridge Trusses. Chas. E. Greene. Published by D. Van Nostrand. New York, 1875.

tain in virtue of its being an equilibrium polygon, and they would induce no bending moments if applied to the arch. The actual loads in general are differently distributed. By Prop. VI the bending moments induced in the truss are those due to the difference between the weight actually resting on the arch at each point, and the weight of the same total amount distributed as shown by the segments of the line uv' .

Now lay off a load line vv' made up of weights which are these differences of the segments of uv' and wv' , taking care to observe the signs of these differences. The algebraic sum of all the weights vv' vanishes when the weights which rest on the piers are included, as appears from inspection of the construction in the lower part of Fig. 10. The construction above described will differ from that in Fig. 10 in one particular. The rib will not in general be parabolic, and the loads which it will sustain in virtue of its being an equilibrium polygon will not be uniformly distributed, hence the differences which are found as the loading of the stiffening truss do not generally constitute a uniformly distributed load.

The horizontal thrust of the arch is the distance of uv' from b measured on the scale on which the loads are laid off, and the thrust along the arch at any point is length of the corresponding ray of the pencil between b and uv' . These thrusts depend only on the total weight sustained, while the bending moments of the stiffening truss depend on the manner in which it is distributed, and on the shape of the arch.

Having determined thus the weights applied to the stiffening truss, it is to be treated as a straight girder, by methods previously explained according to the way in which it is supported at the piers.

The effect of variations of temperature is to make the crown of the arch rise and fall by an amount which can be readily determined with sufficient exactness, (see Rankine's Applied Mechanics Art. 169). This rise or fall of the arch produces bending moments in the stiffening truss, which is fastened to the tops of the piers, which are the same as would be produced by a positive or negative loading, causing the same deflection at

the center and distributed in the same manner as the segments of uv' : for it is such a distribution of loads or pressures which the rib can sustain or produce. A similar set of moments can be induced in the stiffening truss by lengthening the posts between the rib and truss.

When this deflection and the value of EI in the truss are known, these moments can be at once constructed by methods like those already employed. A judicious amount of cambering of this kind is of great use in giving the structure what may be called "initial stiffness." The St. Louis Arch is wanting in initial stiffness to such an extent that the weight of a single person is sufficient to cause a considerable tremor over an entire span. This would not have been possible had the bridge consisted of an arch stiffened by a truss which was anchored to the piers in such a state of bending tension as to exert considerable pressure upon the arch. This tension of the truss would be relieved to some extent during the passage of a live load.

The arch rib with stiffening truss, is a form of which many wooden bridges were erected in Pennsylvania in the earlier days of American railroad building, but its theory does not seem to have been well understood by all who erected them, as the stiffening truss was itself usually made strong enough to bear the applied weights, and the arch was added for additional security and stiffness, while instead of anchoring the truss to the piers and causing it to exert a pressure on the arch, a far different distribution of pressures was adopted. Quite a number of bridges of this pattern are figured by Haupt* from the designs of the builders, but most of them show by the manner of bracing near the piers that the engineers who designed them did not know how to take advantage of the peculiarities of this combination. This further appears from the fact, that the trussing is not usually continuous.

A good example, however, of this combination constructed on correct principles is very fully described by Haupt on pages 169 *et seq.* of his treatise. It is a wooden bridge over the Susquehanna River, $5\frac{1}{2}$ miles from Harrisburg on the

* Theory of Bridge Construction. Herman Haupt, A.M. New York. 1853.

Pennsylvania Railroad, and was designed by Haupt. It consists of twenty-three spans of 160 feet each from center to center of piers. The arches have each a span of $149\frac{1}{4}$ feet and a rise of 20 ft. 10 in., and are stiffened by a Howe Truss which is continuous over the piers and fastened to them. It was erected in 1849. Those parts which were protected from the weather have remained intact, while other parts have been replaced, as often as they have decayed, by pieces of the original dimensions. This bridge, though not designed for the heavy traffic of these days, still stands after twenty-eight years of use, a proof of the real value of this kind of combination in bridge building.

CHAPTER XIII.

THE ARCH OF MASONRY.

Arches of stone and brick have joints which are stiff up to a certain limit beyond which they are unstable. The loading and shape of the arch must be so adjusted to each other that this limit shall not be exceeded. This will appear in the course of the ensuing discussion.

Let us take for discussion the brick arch erected by Brunel near Maidenhead England, to serve as a railway viaduct.

It is in the form of an elliptic ring, as represented in Fig. 14, having a span of 128 ft. with a rise of $24\frac{1}{4}$ feet. The thickness of the ring at the crown is $5\frac{1}{4}$ ft., while at the pier the horizontal thickness is 7 ft. 2 inches.

Divide the span into an even number of equal parts of the type bb , and with a radius of half the span describe the semicircle gg . Let $ba=24\frac{1}{4}$ ft. be the rise of the intrados, and from any convenient point on the line bb as b_5 draw lines to a and g . These lines will enable us to find the ordinates ba of the ellipse of the intrados from the ordinates bg of the circle, by decreasing the latter in the ratio of bg to ba . For example, draw a horizontal through g_3 cutting b_5g at i_3 , then a vertical through i_3 , cutting b_5a at j_3 , then will a horizontal through j_3 cut off a_3b_3 the ordinate of the ellipse corresponding to b_3g_3 in the circle, as appears from known properties of the ellipse.

Similarly let $bq=64$ ft. + 7 ft. 2 in., and with bq as radius describe a semicircle. Let $bd=24\frac{1}{4}$ ft. + $5\frac{1}{4}$ ft. be the rise

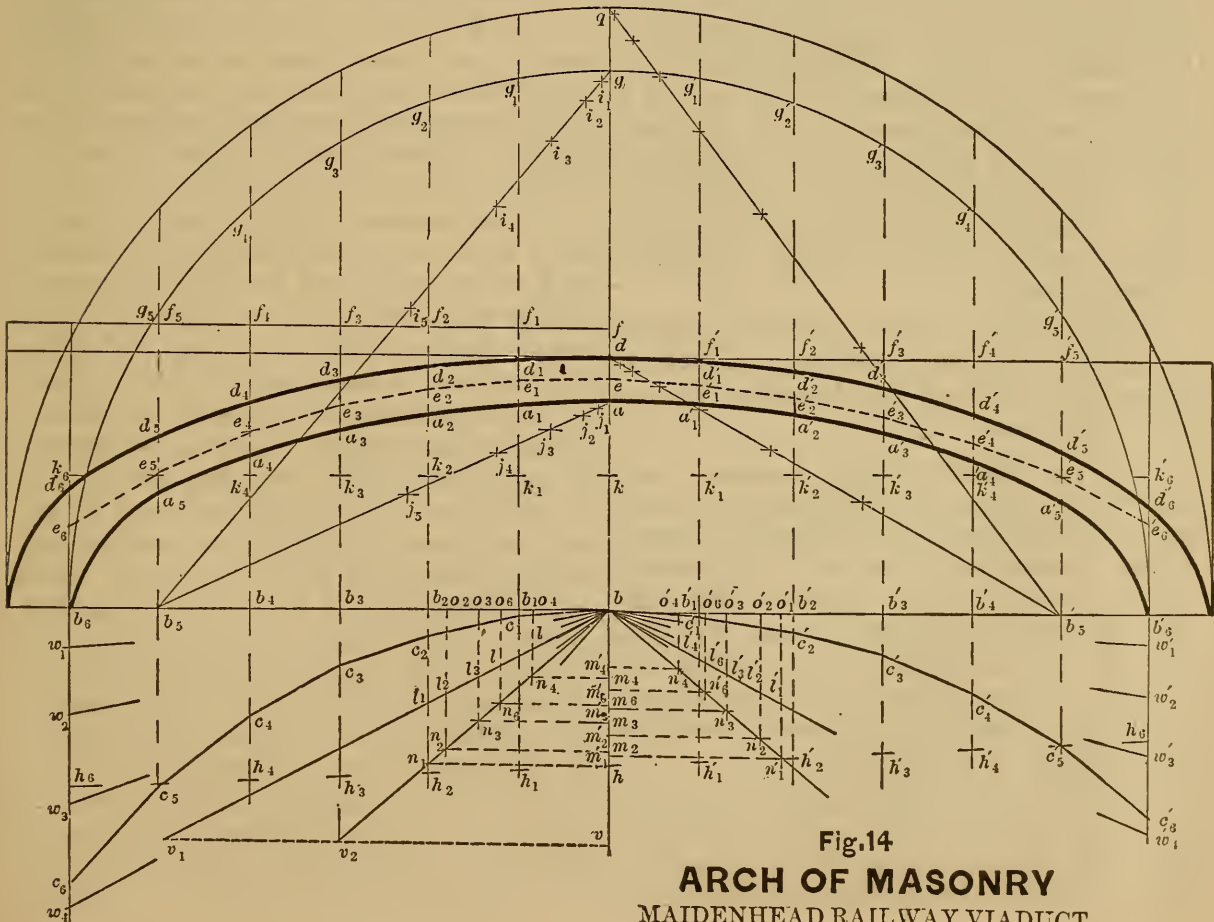

Fig. 14

ARCH OF MASONRY
MAIDENHEAD RAILWAY VIADUCT

of the extrados, and from any convenient point on bb , as b'_e draw lines to d and g . These will enable us to find the ordinates bd of the ellipse of the extrados, from those of the circle, by decreasing the latter in the ratio of bq to bd . By this means, as many points as may be desired, can be found upon the intrados and extrados; and these curves may then be drawn with a curved ruler. We can use the arch ring so obtained for our construction, or multiply the ordinates by any convenient number, in case the arch is too flat for convenient work. Indeed we can use the semicircular ring itself if desirable. We shall in this construction employ the arch ring ad which has just been obtained.

We shall suppose that the material of the surcharge between the extrados and a horizontal line tangent at d causes by its weight a vertical pressure upon the arch. That this assumption is nearly correct in case this part of the masonry is made in the usual manner, cannot well be doubted. Rankine, however, in his Applied Mechanics assumes that the pressures are of an amount and in a direction due to the conjugate stresses of an homogeneous, elastic material, or of a material which like earth has an angle of slope due to internal friction. While this is a correct assumption, in case of the arch of a tunnel sustaining earth, it is incorrect for the case in hand, for the masonry of the surcharge needs only a vertical resistance to support it, and will of itself produce no active thrust, having a horizontal component.

This is further evident from Moseley's principle of least resistance, which is stated and proved by Rankine in the following terms:

"If the forces which balance each other in or upon a given body or structure, be distinguished into two systems, called respectively, *active* and *passive*, which stand to each other in the relation of cause and effect, then will the passive forces be the least which are capable of balancing the active forces, consistently with the physical condition of the body or structure.

For the passive forces being caused by the application of the active forces to the body or structure, will not increase after the active forces have been balanced

by them; and will, therefore, not increase beyond the least amount capable of balancing the active forces."

A surcharge of masonry can be sustained by vertical resistance alone, and therefore will exert of itself a pressure in no other direction upon the haunches of the arch. Nevertheless this surcharge will afford a resistance to horizontal pressure if produced by the arch itself. So that when we assume the pressures due to the surcharge to be vertical alone, we are assuming that the arch does not avail itself of one element of stability which may possibly be employed, but which the engineer will hesitate to rely upon, by reason of the inferior character of the masonry usually found in the surcharge. The difficulty is usually avoided, as in that beautiful structure, the London Bridge, by forming a reversed arch over the piers which can exert any needed horizontal pressure upon the haunches. This in effect increases by so much the thickness of the arch ring at and near the piers.

The pressure of earth will be treated in connection with the construction for the Retaining Wall. On combining the pressures there obtained with the weight, the load which a tunnel arch sustains, may be at once found, after which the equilibrium polygon may be drawn and a construction executed, similar in its general features to that about to be employed in the case before us.

Let us assume that the arch is loaded with a live load extending over the left half of the span, and having an intensity which when reduced to masonry of the same specific gravity as that of which the viaduct is built, would add a depth df to the surcharge. Now if the number of parts into which the span is divided be considerable, the weights which may be supposed to be concentrated at the points of division vary very approximately as the quantities of the type af . This approximation will be found to be sufficiently exact for ordinary cases; but should it be desired to make the construction exact, and also to take account of the effect of the obliquity of the joints in the arch ring, the reader will find the method for obtaining the centers of gravity, and constructing the weights, in Woodbury's Treatise on the Stability of the Arch pp. 405 *et seq.* in which is

given Poncelet's graphical solution of the arch.

With any convenient pole distance, as one half the span, lay off the weights. We have used b as the pole and made $b_6 w_1 = \frac{1}{2}$ the weight at the crown $= \frac{1}{4} (af + ad) = b'_6 w_1$, $w_1 w_2 = a_1 f_1$, $w_2 w_3 = a_2 f_2$, etc. Several of the weights near the ends of the span are omitted in the Figure; viz., $w_4 w_5$, etc. From the force polygon so obtained, draw the equilibrium polygon c as previously explained.

The equilibrium polygon which expresses the real relations between the loading and the thrust along the arch, is evidently one whose ordinates are proportional to the ordinates of the polygon c .

It has been shown by Rankine, Woodbury and others, that for perfect stability, —i.e. in case no joint of the arch begins to open, and every joint bears over its entire surface,—that the point of application of the resultant pressure must everywhere fall within the middle third of the arch ring. For if at any joint the pressure reaches the limit zero, at the intrados or extrados, and uniformly increases to the edge farthest from that, the resultant pressure is applied at one third of the depth of the joint from the farther edge.

The locus of this point of application of the resultant pressure has been called the "curve of pressure," and is evidently the equilibrium curve due to the weights and to the actual thrust in the arch. If then it be possible to use such a pole distance, and such a position of the pole, that the equilibrium polygon can be inscribed within the inner third of the thickness of the arch ring, the arch is stable. It may readily occur that this is impossible, but in order to ensure sufficient stability, no distribution of live load should be possible, in which this condition is not fulfilled.

We can assume any three points at will, within this inner third, and cause a projection of the polygon c to pass through them, and then determine by inspection whether the entire projection lies within the prescribed limits. In order to so assume the points that a new trial may most likely be unnecessary, we take note of the well known fact, that in arches of this character, the curve of pressure is likely to fall without the pre-

scribed limits near the crown and near the haunches. Let us assume e at the middle of the crown, e'_5 at the middle of $a'_5 d'_5$, and e_5 near the lower limit on $a_5 d_5$. This last is taken near the lower limit, because the curvature of the left half of the polygon is more considerable than the other, and so at some point between it and the crown it may possibly rise to the upper limit. The same consideration would have induced us to raise e'_5 to the upper limit, were it not likely that such a procedure would cause the polygon to rise above the upper limit on the right of e'_5 .

Draw the closing line kk through $e_5 e'_5$, and the corresponding closing line hh through $c_5 c'_5$, and decrease all the ordinates of the type hc in the ratio of hb to ke , by help of the lines bn and bl , in a manner like that previously explained. For example $h_3 c_3 = n_3 o_3$, and $l_3 o_3 = k_3 e_3$. By this means we obtain the polygon e which is found to lie within the required limits. The arch is then stable: but is the polygon e the actual curve of pressures? Might not a different assumption respecting the three points through which it is to pass lead to a different polygon, which would also lie within the limits? It certainly might. Which of all the possible curves of pressure fulfilling the required condition, is to be chosen, is determined by Moseley's principle of least resistance, which applied to the case in hand, would oblige us to choose that curve of all those lying within the required limits, which has the least horizontal thrust, i.e. the smallest pole distance. It appears necessary to direct particular attention to this, as a recent publication on this subject asserts that the true pressure line is that which approaches nearest to the middle of the arch ring, so that the pressure on the most compressed joint edge is a minimum; a statement at variance with the theorem of least resistance as proved by Rankine.

Now to find the particular curve which has the least pole distance, it is evidently necessary that the curve should have its ordinates as large as possible. This may be accomplished very exactly, thus: above e_1 where the polygon approaches the upper limit more closely than at any other point near the crown, assume a new position of e_1 at the upper limit; and be-

low e_4' where it approaches the lower limit most nearly on the right, assume a new position of e_4' at the lower limit. At the left e_5 may be retained. Now on passing the polygon through these points it will fulfill the second condition, which is imposed by the principle of least resistance.

A more direct method for making the polygon fulfill the required condition will be given in Fig. 18.

It is seen in the case before us, the changes are so minute that it is useless to find this new position of the polygon, and its horizontal thrust. The thrust obtained from the polygon e in its present position is sufficiently exact. The horizontal thrust in this case is found from the lines bn and bl . Since $2vv_2$ is the horizontal thrust, *i.e.* pole distance of the polygon c , $2vv_1$ is the horizontal thrust of the polygon e .

By using this pole distance and a pole properly placed, we might have drawn the polygon e with perhaps greater accuracy than by the process employed, but that being the process employed in Figs. 2, 3, etc., we have given this as an example of another process.

The joints in the arch ring should be approximately perpendicular to the direction of the pressure, *i.e.* normal to the curve of pressures.

With regard to what factor of safety is proper in structures of this kind, all engineers would agree that the material at the most exposed edge should never be subjected to a pressure greater than one fifth of its ultimate strength. Owing to the manner in which the pressure is assumed to be distributed in those joints where the point of application of the resultant is at one third the depth of the joint from the edge, its intensity at this edge is double the average intensity of the pressure over the entire joint. We are then led to the following conclusion, that the total horizontal thrust (or pressure on any joint) when divided by the area of the joint where this pressure is sustained ought to give a quotient at least ten times the ultimate strength of the material. The brick viaduct which we have treated is remarkable in using perhaps the smallest factor of safety in any known structure of this class, having

at the most exposed edge a factor of only $3\frac{1}{2}$ instead of 5.

It may be desirable in a case like that under consideration, to discuss the changes occurring during the movement of the live load, and that this may be effected more readily, it is convenient to draw the equilibrium polygons due to the live and dead loads separately. The latter can be drawn once for all, while the former being due to a uniformly distributed load can be obtained with facility for different positions of the load. The polygon can be at once combined into a single polygon by adding the ordinates of the two together. Care must be taken, however, to add together only such as have the same pole distance. In case the construction which has been given should show that the arch is unstable, having no projection of the equilibrium polygon which can be inscribed within the middle third of the arch ring, it is possible either to change the shape of the arch slightly, or increase its thickness, or change the distribution of the loading. The last alternative is usually the best one, for the shape has been chosen from reasons of utility and taste, and the thickness from consideration of the factor of safety. If the center line of the arch ring (or any other line inscribed within the middle third) be considered to be an equilibrium polygon, and from a pole, lines be drawn parallel to the segments of this polygon, a weight line can be found which will represent the loading needed to make the arch stable. If this load line be compared with that previously obtained, it will be readily seen where a slight additional load must be placed, or else a hollow place made in the surcharge, such as will render the arch stable. In general, it may be remarked, that an additional load renders the curvature of the line of pressures sharper under it, while the removal of any load renders the curve straighter under it.

The foregoing construction is unrestricted, and applies to all unsymmetrical forms of arches or of loading, or both. As previously mentioned, a similar construction applies to the case of an arch sustaining the pressure of water or earth; in that case, however, the load is not applied vertically and the weight line becomes a polygon.

CHAPTER XIV.

RETAINING WALLS AND ABUTMENTS.

Let $aa'b'b$ in Fig. 15 represent the cross section of a wall of masonry which retains a bank of earth having a surface aa_6 . Assume that the portion of the wall and earth under consideration is bounded by two planes parallel to the plane of the paper, and at a unit's distance from each other: then any plane containing the edge of the wall at b , as ba_0, ba_1 , etc., cuts this solid in a longitudinal section, which is a rectangle having a width of one unit, and a length ba_0, ba_1 , etc.

The resultant of the total pressure distributed over any one of these rectangles of the type ba is applied at one-third of that distance from b : *i.e.* the resultant pressure exerted by the earth against the rectangle at ba_0 is applied at a distance of $bk = \frac{1}{3} ba_0$ from b .

That the resultant is to be applied at this point, is due to the fact that the distributed pressure increases uniformly as

we proceed from any point a of the surface toward b : the center of pressure is then at the point stated, as is well known.

Again, the direction of the pressures against any vertical plane, as that at ba_0 , is parallel to the surface aa_0 : This fact is usually overlooked by those who treat this subject, and some arbitrary assumption is made as to the direction of the pressure.

That the thrust of the earth against a vertical plane is parallel to the ground surface is proved analytically in Rankine's Applied Mechanics on page 127; which proof may be set forth in an elementary manner by considering the small parallelopiped mn , whose upper and lower surfaces are parallel to the ground surface. Since the pressure on any plane parallel to the surface of the ground is due to the weight of the earth above it, the pressure on such a plane is vertical and uniformly distributed. If mn were a rigid body, it would be held in equilibrium by these vertical pressures, which are, therefore, a system of forces

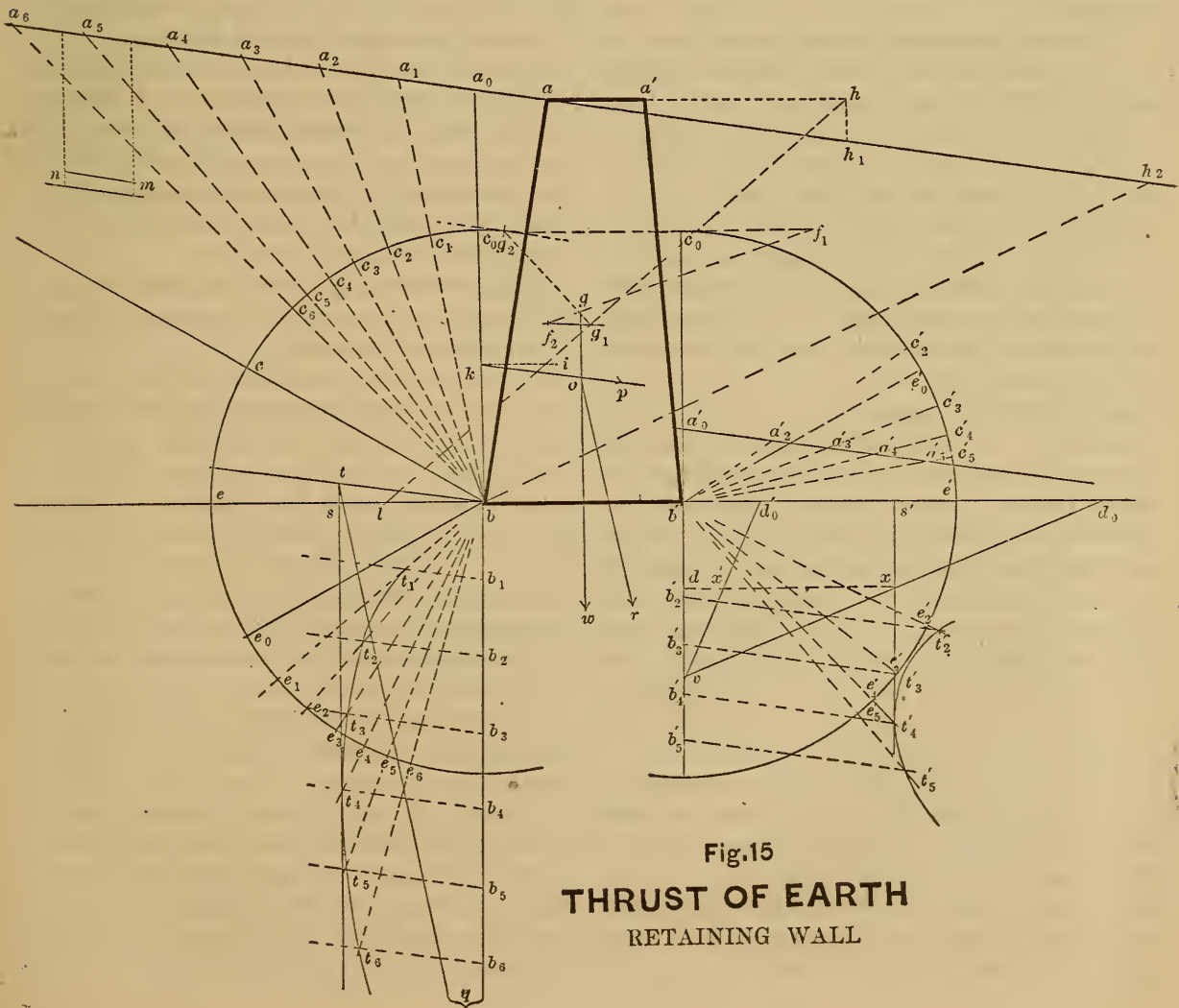

Fig.15
THRUST OF EARTH
RETAINING WALL

in equilibrium; but as mn is not rigid it must be confined by pressures distributed over each end surface, which last are distributed in the same manner on each end, because each is at the same depth below the surface. Now the vertical pressures and end pressures hold mn in equilibrium: they therefore form a system in equilibrium. But the vertical pressures are independently in equilibrium, therefore the end pressures alone form a system which is independently in equilibrium. That this may occur, and no couple be introduced, these must directly oppose each other; *i.e.* be parallel to the ground line aa_5 .

Draw $kp \parallel aa_4$, it then represents the position and direction of the resultant pressure upon the vertical ba_0 . Draw the horizontal ki , then is the angle ikp called the *obliquity* of the pressure, it being the angle between the direction of the pressure and the normal to the plane upon which the pressure acts.

Let $ebc = \Phi$ be the *angle of friction*, *i.e.* the inclination which the surface of ground would assume if the wall were removed.

The obliquity of the pressure exerted by the earth against any assumed plane, such as ba_3 or ba_4 , must not exceed the angle of friction; for should a greater obliquity occur the prism of earth, a_0ba_3 or a_0ba_4 , would slide down the plane, ba_3 or ba_4 , on which such obliquity is found.

For dry earth Φ is usually about 30° ; for moist earth and especially moist clay, Φ may be as small as 15° . The inclination of the ground surface aa_4 cannot be greater than Φ .

Now let the points a_1, a_2, a_3 , etc., be assumed at any convenient distances along the surface: for convenience we have taken them at equal distances, but this is not essential. With b as a center and any convenient radius, as bc , describe a semi-circumference cutting the lines ba_1, ba_2 , etc. at c_1, c_2 , etc. Make $ee_0 = ec$; also $e_0e_1 = c_0c_1, e_0e_2 = c_0c_2$, etc.: then be_0 has an obliquity Φ with ba_0 , as has also be_1 with ba_1, be_2 with ba_2 , etc.; for $a_0be_0 = a_1be_1 = a_2be_2 = 90^\circ + \Phi$.

Lay off bb_1, bb_2, bb_3 , etc., proportional to the weights of the prisms of earth $a_0ba_1, a_0ba_2, a_0ba_3$, etc.: we have effected this most easily by making $a_0a_1 = bb_1, a_0a_2 = bb_2, a_0a_3 = bb_3$, etc. Through b, b_1, b_2 , etc., draw parallels to kp ; these will intersect be_0, be_1, be_2 , etc., at t, t_1, t_2 , etc.

Then is bb_1t_1 the triangle of forces holding the prism a_0ba_1 in equilibrium, just as it is about to slide down the plane ba_1 , for bb_1 represents the weight of the prism, b_1t_1 is the known direction of the thrust against ba_0 , and bt_1 is the direction of the thrust against ba_1 when it is just on the point of sliding: then is t_1b_1 the greatest pressure which the prism can exert against ba_0 . Similarly t_2b_2 is the greatest pressure which the prism a_0ba_2 can exert. Now draw the curve $t_1t_2t_3$, etc., and a vertical tangent intersecting the parallel to the surface through b at t ; then is tb the greatest pressure which the earth can exert against ba_0 . This greatest pressure is exerted approximately by the prism or wedge of earth cut off by the plane ba_4 , for the pressure which it exerts against the vertical plane through b is almost exactly $b_4t_4 = bt$. This is Coulomb's "wedge of maximum thrust" correctly obtained: previous determinations of it have been erroneous when the ground surface was not level, for in that case the direction of the pressure has not been ordinarily assumed to be parallel to the ground surface.

In case the ground surface is level the wedge of maximum thrust will always be cut off by a plane bisecting the angle cbc_0 , as may be shown analytically, which fact will simplify the construction of that case, and enable us to dispense with drawing the thrust curve tt .

The pressure tb is to be applied at k , and may tend either to overturn the wall or to cause it to slide.

In order to discuss the stability of the wall under this pressure, let us find the weight of the wall and of the prism of earth aba_0 . Let us assume that the specific gravity of the masonry composing the wall is twice that of earth. Make $a'h = bb'$, then the area $abb'a' = abh = abh_1$; and if $ah_2 = 2ah$, then ah_2 represents the weight of the wall reduced to the same scale as the prisms of earth before used. Since aa_0 is the weight of aba_0 , a_0h_2 is the weight of the mass on the right of the vertical ba_0 against which the pressure is exerted.

Make $bq = a_0h_2$, and draw tq , which then represents the direction and amount of the resultant to be applied at o where the resultant pressure applied at k intersects the vertical gw through the center of gravity g of the mass $aa_0bb'a'$. The

center of gravity g is constructed in the following manner. Lay off $a'h=bb'$, and $bl=aa'$; and join hl . Join also the middle points of ab and $a'b'$: the line so drawn intersects hl at g_1 , the center of gravity of $aa'b'b$. Find also the center of gravity g_2 , of aba_0 , which lies at the intersection of a line parallel to aa_0 , and cutting ba_0 at a distance of $\frac{1}{3}ba_0$ from a_0 and of a line from b bisecting aa_0 . Through g_2 and g_1 draw parallels, and lay off g_2f_1 and g_1f_2 on them proportional to the weights applied at g_1 and g_2 respectively. We have found it convenient to make $g_2f_1=\frac{1}{2}ah_2$, and $g_1f_2=\frac{1}{2}aa_0$. Then f_1f_2 divides g_1g_2 inversely as the applied weights; and g , the point of intersection, is the required center of gravity.

Let or be parallel to tq ; since it intersects bb' so far within the base, the wall has sufficient stability against overturning. The base of the wall is so much greater than is necessary for the support of the weight resting upon it, that engineers have not found it necessary that the resultant pressure should intersect the base within the middle third of the joint. The practice of English engineers, as stated by Rankine, is to permit this intersection to approach as near b' as $\frac{1}{3}bb'$, while French engineers permit it to approach as near as $\frac{1}{5}bb'$ only. In all cases of buttresses, piers, chimneys, or other structures which call into play some fraction of the ultimate strength of the material, or ultimate resistance of the foundation as great as one tenth, or one fifteenth, the point should not approach b' nearer than $\frac{1}{3}bb'$.

Again, let the angle of friction between the wall and the earth under it be Φ' : then in order that the thrust at k may not cause the wall to slide, the angle wor must be less than Φ' .

When, however, the angle Φ' is less than wor it becomes necessary to gain additional stability by some means, as for example by continuing the wall below the surface of the ground lying in front of it. Let $a_0'a_3'$ be the surface of the ground which is to afford a *passive* resistance to the thrust of the wall: then in a manner precisely analogous to that just employed for finding the greatest active pressure which earth can exert against a vertical plane, we now find the least passive pressure which the earth in front of the

wall will sustain without sliding up some plane such as $b'a_3'$ or $b'a_4'$, etc. The difference in the two cases is that in the former case friction hindered the earth from sliding down, while it now hinders it from sliding up the plane on which it rests.

Lay off $e'e_0'=ee_0$; then taking any points $a_2'a_3'$, etc. on the ground surface, make $e_0'e_2'=c_0'e_2'$, $e_0'e_3'=c_0'e_3'$, etc.

Lay off $b'b_2'=a_0'a_2'$, etc., and drawing parallels through b_2' , b_3' , etc., we obtain the thrust curve $t_2't_3'$, etc.

The small prism of earth between $b'a_0'$ and the wall adds to the stability of the wall, and can be made to enter the construction if desired, in the same manner as did aba_0 .

The vertical tangent through s' shows us that the earth in front of the wall can withstand a thrust having a horizontal component $b's'$ measured on a scale such that $b'b_2'=a_0'a_2'$ is the weight of the prism of earth $a_0'b'a_2'$.

This scale is different from that used on the left. To reduce them to the same scale lay off from b' , the distances $b'd_0$ and $b'd_0'$ proportional to the perpendiculars from b on aa_4 and b' on $a_1'a_4'$ respectively. In the case before us, as the ground surfaces are parallel, we have made $b'd_0=ba_0$ and $b'd_0'=b'a_0'$.

Then from any convenient point on $b'b_4'$, as v , draw vd_0 and vd_0' : these lines will reduce from one scale to the other. We find then that $x'd$ is the thrust on the scale at the left corresponding to $xd=b's'$ on the right: *i.e.*, the earth under the surface assumed at the right can withstand something over one fourth of the thrust sb at the left.

It will be found that a certain small portion of the earth near a_0' has a thrust curve on the left of b' , but as it is not needed in our solution it is omitted.

If any pressure is required in pounds, as for example sb , it is found as follows:—the length of ah_2 is to that of sb as the weight of $bb'ad'$ in lbs. is to the pressure sb in lbs.

Frequently the ground surface is not a plane, and when this is the case it often consists of two planes as ad , da_1 , Fig. 16. In that case, draw some convenient line as ad_1 , and lay off ad_1 , d_1d_2 , etc. at will, which for convenience we have made equal. Draw d_1a_1 , d_2a_2 , etc. parallel to bd , and join ba_1 , ba_2 , etc.: then are the

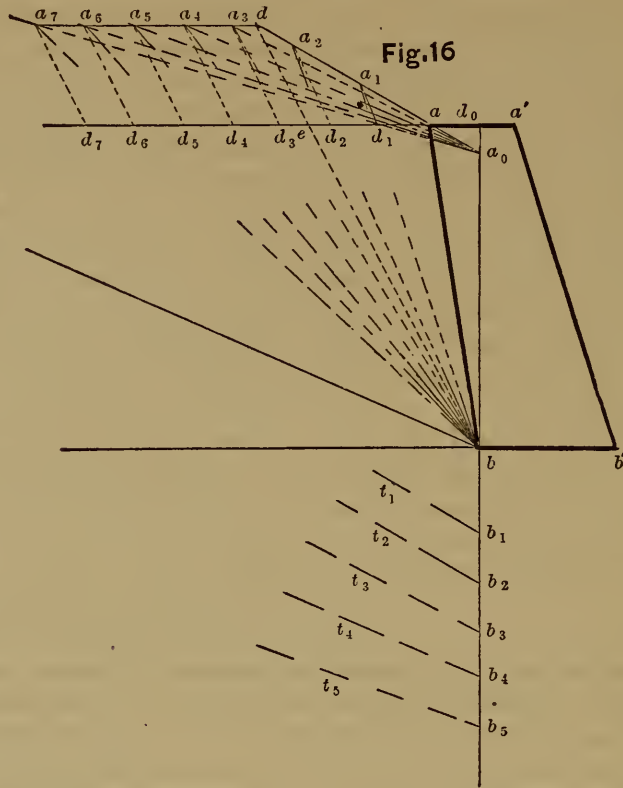

triangles bda, bda_1, bda_2, bda_3 , etc. proportional in area to the lines ea, ea_1 , etc. Hence the weights of the prisms of earth baa_1, baa_2 , etc., are proportional to ad_1, ad_2 , etc.

In case ab slopes backward the part of the wall at the left of the vertical ba_0 rests upon the earth below it sufficiently to produce the same pressure which would be produced if baa_0 were a prism of earth. The weights of the wedges which produce pressures, and which are to be laid off below b , are then proportional to $d_0d_1=bb_1, d_0d_2=bb_2$, etc. The direction of the pressures of the prisms at the right of bd are parallel to ad ; but upon taking a larger prism the direction may be assumed to be parallel to a_0a_1, a_0a_2 , etc., which is very approximately correct. Now draw $b_1t_1 \parallel a_0a_1, b_4t_4 \parallel a_0a_4$, etc.; and complete the construction for pressure precisely as in Fig. 15, using for resultant pressure the direction and amount of that due to the wedge of maximum pressure thus obtained.

In finding the stability of the wall, it will be necessary to find the weight and center of gravity of the wall itself, minus a prism of earth baa_0 , instead of plus this prism as in Fig. 15; for it is now sustained by the earth back of the wall.

When the back of the wall has any

other form than that above treated, the vertical plane against which the pressure is determined should still pass through the lower back edge of the wall.

In case the wall is found to be likely to slide upon its foundations when these are level, a sloping foundation is frequently employed, such that it shall be nearly perpendicular to the resultant pressure upon the base of the wall. The construction employed in Fig. 15 applies equally to this case.

The investigation of the stability of any abutment, buttress, or pier, against overturning and against sliding, is the same as that of the retaining wall in Fig. 15. As soon as the amount, direction, and point of application, of the pressure exerted against such a structure is determined, it is to be treated precisely as was the resultant pressure kp in Fig. 15.

In the case of a reservoir wall or dam, the construction is simplified from the fact that, since the surface of water is level and the angle of friction vanishes, the resultant pressure is perpendicular to the surface upon which the water presses. It is useful to examine this as a case of our previous construction. In Fig. 17, let abb' be the cross-section of the dam; then the wedge of maximum pressure against ba_0 is cut off by the

plane ba_1 when $cba_1 = 45^\circ$, i.e. ba_1 bisects cba_0 as before stated.

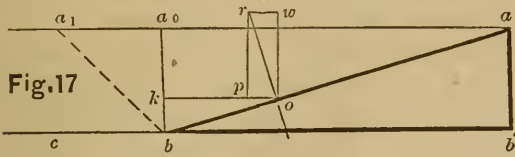

This produces a horizontal resultant pressure at k equal to the weight of the wedge. Now the total pressure on ab is the resultant of this pressure, and the weight of the wedge aba_0 . The forces to be compounded are then proportional to the lines $a_1a_0 = bv_0$ and aa_0 . By similarity of triangles it is seen that ro the resultant is perpendicular to ab .

It is seen that by making the inclination of ab small, the direction of ro can be made so nearly vertical that the dam will be retained in place by the pressure of the water alone, even though the dam be a wooden frame, whose weight may be disregarded.

We can now construct the actual pressures to which the arch of a tunnel surcharged with water or earth is subjected. Suppose, for example, we wish to find the pressure of such a surcharge on the voussoir $a_4d_4d_5a_5$ Fig. 14. Find the resultant pressure against a vertical plane extending from d_5 to the upper surface of the surface and call it p_5 . Draw a horizontal through d_4 and let its intersection with the vertical just mentioned be called d_5'' . Find the resultant pressure against the vertical plane extending from d_5'' to the surface, and call it p_5' . Now let $p_5'' = p_5 - p_5'$ and let it be applied at such a point of d_5d_5'' that p_5 shall be the resultant of p_5' and p_5'' . Then will the resultant pressure against the voussoir be the resultant of p_5'' and the weight of that part of the surcharge directly above it.

FOUNDATIONS IN EARTH.

A method similar to that employed in the determination of the pressure of earth against a retaining wall, or a tunnel arch, enables us to investigate the stability of the foundations of a wall standing in earth.

Suppose in Fig. 15 that the wall $abb'a'$ is a foundation wall, and that the pressure which it exerts upon the plane bb' is vertical, being due to its own weight and the weight of the building or other

load which it sustains. Now consider a vertical plane of one unit in height, say, as bb_1 ; and determine the resultant pressure against it on the supposition that the pressure is produced by a depth of earth at the right of it, sufficient to produce the same vertical pressure on bb' which the wall and its load do actually produce. In other words we suppose the wall and load replaced by a bank of earth having its upper surface horizontal and weighing the same as the wall and load. Call the upper surface z , and find the pressure against the vertical plane zb due to the earth under the given level surface; similarly, find the pressure against zb_1 . The surface being level, the maximum pressure, as previously stated will be due to a wedge cut off by a plane bisecting the angle between bz and a plane drawn from b at the inclination Φ , of the limiting angle of friction. This enables us to find the horizontal pressures against zb and zb_1 directly: their difference is the resultant active pressure against bb_1 .

Next, it must be determined what passive pressure the earth at the left of bb_1 can support. The passive resistance of the earth under the surface a against the plane ab as well as that against the plane ab_1 can be found exactly as that was previously found under the surface a' . The difference of these resistances is the resistance which it is possible for bb_1 to support. Indeed bb_1 could support this pressure and afford this resistance even if the active pressure against ab were, at the limit of its resistance, which it is not. The limiting resistance which is thus obtained, is then so far within the limits of stability, that ordinarily, no further factor of safety is needed, and the stability of the foundation is secured, if the active pressure against bb_1 does not exceed the passive resistance. This construction should be made on the basis of the smallest angle of friction Φ which the earth assumes when wet; that being smaller than for dry earth, and hence giving a greater active pressure at the right, and a less resistance at the left.

CHAPTER XV.

SPHERICAL DOME OF METAL.

The dome which will be treated in the following construction is hemispherical in shape; but the proposed construction

applies equally to domes of any different form generated by the revolution of the arc of some curve about a vertical axis: such forms are elliptic, parabolic or hyperbolic domes, as well as pointed or gothic domes, etc. Let the quadrant aa in Fig. 18, represent the part of the meridian section of a thin metallic dome between the crown and the springing circle. The metallic dome is supposed to be so thin that its thickness need not be represented in the Figure: the thickness of a dome of masonry, however, is a matter of prime importance and will be treated subsequently.

In a thin metallic dome the only thrust along a meridian section is necessarily in a direction tangent to that section at each point of it. This consideration will enable us to determine this thrust as well

as the hoop tension or compression along any of the conical rings into which the dome may be supposed to be divided by a series of horizontal planes.

Let the height ab of the dome be divided into any number of parts, which we have in this case, for convenience, made equal. Let these equal parts of the type du be the distances between horizontal planes such that the planes through the points d_1, d_2 , etc., cut small circles from the hemisphere which pass through the point a_1, a_2 , etc., and similarly the planes through v_1, v_2 , etc., cut small circles which pass through g_1, g_2 , etc. Now suppose the thickness of this dome to be uniform, and if ab be taken to represent the weight of a quadrantal lune of the dome included between two meridian planes making some small angle with each other; then

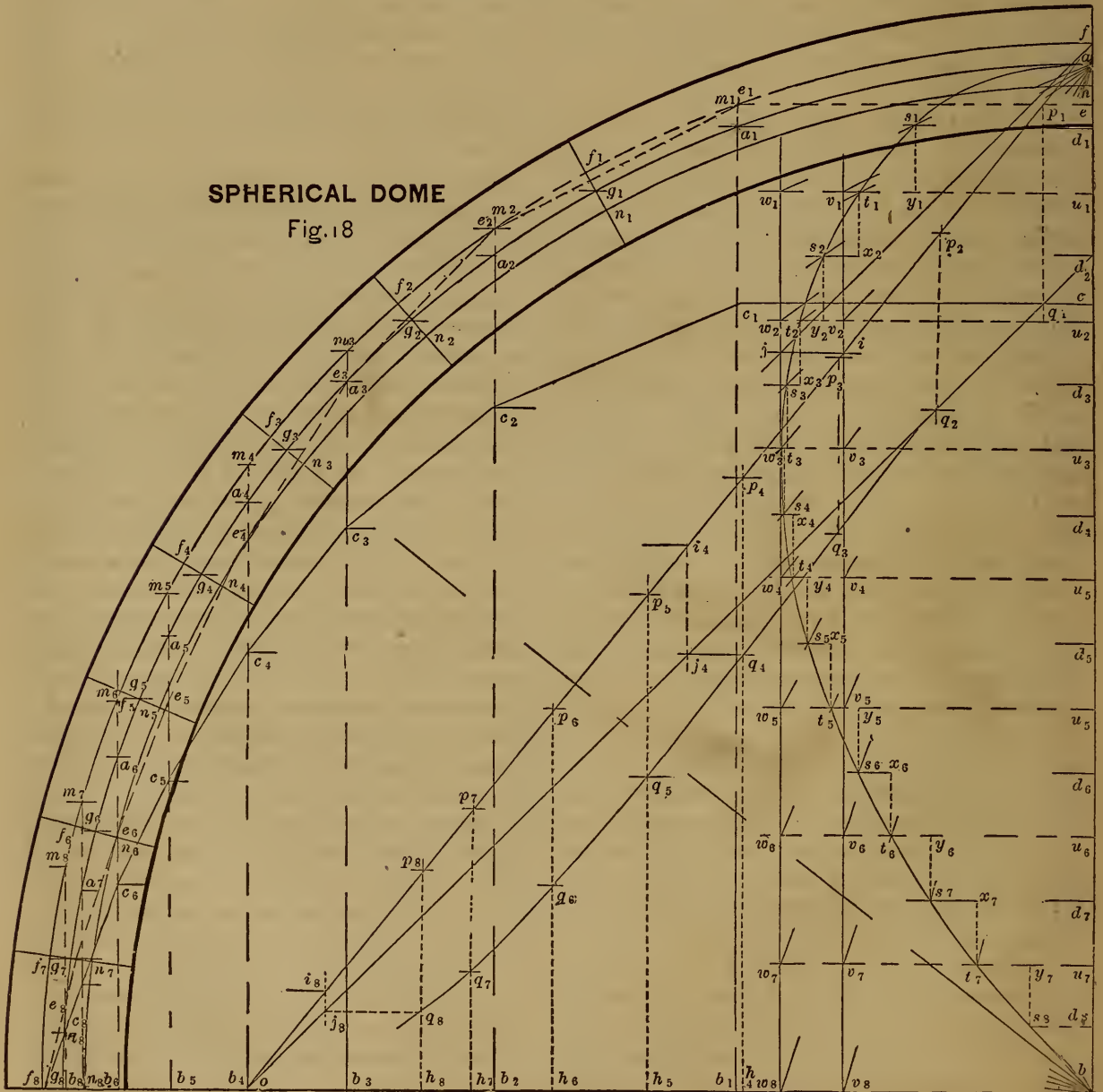

from the well-known expression for the area of the zone of a sphere it appears that ad_1 will represent the weight of that part of the lune above a_1d_1 . Similarly au_1 is the weight of the lune ag_1 ; ad_2 the weight of aa_2 , etc.

This method of obtaining the weight applies of course in case the dome is any segment of a sphere less than a hemisphere and of uniform thickness. If the thickness increases from the crown, the weights of the zones cut by equi-distant horizontal planes increase directly as the thickness. In case the dome is not spherical the weights must be determined by some process suited to the form of the dome and its variation in thickness.

Now the weight of the lune aa_1 is sustained by a horizontal thrust which is the resultant of the horizontal pressures in the meridian planes by which it is bounded, and by a thrust, as before remarked, in the direction of the tangent at a_2 . Draw a horizontal line through d_1 , and through a a parallel to the tangent at a_1 ; these intersect at s_1 , then is ad_1s_1 the triangle of forces which hold in equilibrium the lune aa_1 . Similarly, au_1t_1 is the triangle of forces holding the lune ag_1 in equilibrium, etc. Draw a curve st through the points thus determined. This curve is a well-known cubic which when referred to ba as the axis of x and bg_1 as that of y has for its equation

$$\frac{y^2}{x^2} = \frac{r-x}{r+x}$$

On being traced at the right of a it has in the other quadrant of the dome a part like that here drawn forming a loop; it passes through b at an inclination of 45° and the two branches below b finally become tangent to a horizontal line drawn tangent to the circle aa of the dome. The curve has this remarkable property:—If any line be drawn from a , cutting the curve here drawn and, also, the part below bg_1 , the product of these two radii vectores of the curve from the pole a is constant, and the locus of the intersection of the normals at these two points is a parabola.

Draw a vertical tangent to this curve: the point of contact is very near t_3 , and g_3 , the corresponding point of the dome is almost 52° from the crown a . A determination of this maximum point by means

of the equation gives the height of it above b as $\frac{1}{2}(\sqrt{5}-1)r$, corresponding to about $51^\circ 49'$. Now consider any zone, as, for example, that whose meridian section is g_1a_2 : the upper edge is subjected to a thrust whose radial horizontal component is proportional to u_1t_1 , while the horizontal thrust against its lower edge is proportional to d_2s_2 , and the difference s_2x_2 between these radial forces produces a hoop compression around the zone proportional to s_2x_2 . It will be seen that these differences which are of the type sx or ty , change sign at t_3 . Hence all parts of the dome above $51^\circ 49'$ from the crown, are subjected to a hoop compression which vanishes at that distance from a , while all parts of the dome below this are subjected to hoop tension. This may be stated by saying that a thin dome of masonry would be stable under hoop compression as far as $51^\circ 49'$ from the crown, but unstable below that, being liable to crack open along its meridian sections. A thick dome of masonry, however, does not have the resultant thrust at every point of its meridian section in a direction which is tangential to its surface,—this will be discussed later.

It is necessary to determine the actual hoop tension or compression in any ring in order to determine the thickness of the dome such that the metal may not be subjected to too severe a stress.

The rule for obtaining hoop tension (we shall use the word tension to include both tension and compression) is: Multiply the intensity of the radial pressure by the radius of the hoop, the product is the tension at any meridian section of the hoop. The correctness of this rule appears at once from consideration of fluid pressure in a tube, in which it is seen that the tensions at the two extremities of a diameter prevent the total pressure on that diameter from tearing the tube asunder.

Now in the case before us t_1y_1 is the radial force distributed along a certain lune. The number of degrees of which the lune consists is at present undetermined: let it be determined on the supposition that it shall be such a number of degrees as to cause that the total radial force against it shall be equal to the hoop tension. Call the total radial force P and the hoop tension T , then the lune

is to be such that $P=T$. Also let θ be the number of degrees in the lune, then $90^\circ \div \theta$ is the number of lunes in a quarter of the dome, and $90 P \div \theta$ is the radial force against a quarter of the dome, which last must be divided by $\frac{1}{2}\pi$ to obtain the hoop tension; because if p is the intensity of radial pressure, $\frac{1}{2}\pi r p$ is the total pressure against a quadrant and $r p$, as previously stated, is the hoop tension. The ratio of these is $\frac{1}{2}\pi$, and by this we must divide the total radial pressure in every case to obtain hoop tension

$$\therefore \frac{180 P}{\theta \pi} = T, \quad \therefore \theta = \frac{180^\circ}{\pi}$$

for $P=T \quad \therefore \theta = 57^\circ.3-$

This is the number of degrees of which the lune must consist in order that when ab represents its weight, $t_1 y_1$ shall represent the hoop tension in the meridian section $a_1 g_1$. The expression we have found is independent of the radius of the ring, and hence holds for any other ring as $g_1 a_2$, in which $s_2 x_2$ is the hoop tension, etc. To find what fraction this lune is of the whole dome, divide θ by 360°

$$\therefore \frac{\theta}{360} = \frac{180}{360\pi} = \frac{1}{2\pi} = \frac{4}{25} \text{ nearly,}$$

from which the scale of weight is easily found, thus; let W be the total weight of the dome and r its radius, then

$2\pi r : W :: 1 : n$, the weight per unit, or the hoop tension per unit of the distances ty or sx .

Distances at or as , on the same scale, represent the thrust tangential to the dome in the direction of the meridian sections, and uniformly distributed over an arc of $57^\circ.3-$: e.g. if we divide at_2 measured as a force by $\theta \times u_2 g_2$ measured as a distance we shall obtain the intensity of the meridian compression at the joint cut from the dome by the horizontal plane through a_2 .

Analogous constructions hold for domes not spherical and not of uniform thickness. Approximate results may be obtained by assuming a spherical dome, or a series of spherical zones approximating in shape to the form which it is desired to treat.

CHAPTER XVI.

SPHERICAL DOME OF MASONRY.

Let the dome treated be that in Fig. 18 in which the uniform thickness of the masonry is one-sixteenth of the internal diameter or one-eighth of the radius of the intrados. Divide ab the radius of the center line into any convenient number of equal parts, say eight, at u_1, u_2 , etc.: a much larger number would be preferable in actual construction. At the points a_1, a_2 , etc., on the same levels with u_1, u_2 , etc. pass conical joints normal to the dome, so that b is the vertex of each of the cones.

If we consider a lune between meridian planes making a small angle with each other, the center of gravity of the parts of the lune between the conical joints lie at g_1, g_2 , etc. on the horizontal midway between the previous horizontals. These points are not exactly upon the central line aa , but if the number of horizontals is large, the difference is inappreciable. We assume them upon aa . That they fall upon the horizontals through d_1, d_2 , etc., midway between those through u_1, u_2 , etc., is a consequence of the equality in area between spherical zones of the same height.

In finding the volume of a sphere it may be considered that we take the sum of a series of elementary cones whose bases form the surface of the sphere, and whose height is the radius. Hence, if any equal portions of the surface of a sphere be taken and sectorial solids be formed on them as bases and having their vertices at the center, then the sectorial solids have equal volumes. The lunes of which we treat are equal fractions of such equal solids.

Draw the verticals of the type bg through the centers of gravity g_1, g_2 , etc. The weights applied at these points are equal and may be represented by $au_1, u_1 u_2 = w_1 w_2$, etc. Use a as the pole and $w_1 w_2$ as the weight line; and, beginning at the point f_s , draw the equilibrium polygon c due to the weights.

We have used for pole distance the greatest horizontal thrust which it is possible for any segment of the dome to exert upon the part below it, when the hoop compression extends to $51^\circ 49'$ from the crown.

Below the point where the compression

vanishes we shall not assume that the bond of the masonry is such that it can resist the hoop tension which is developed. The upper part of the dome will be then carried by the parts of the lunes below this point by their united action as a series of masonry arches standing side by side.

Now it is seen that the curve of equilibrium c , drawn with this assumed horizontal thrust falls within the curve of the lune, which signifies that the dome will not exert so great a thrust as that assumed. By the principle of least resistance, no greater horizontal thrust will be called into action than is necessary to cause the dome to stand, if stability is possible. If a less thrust than that just employed be all that is developed in the dome, then the point where the hoop compression vanishes is not so far as $51^{\circ} 49'$ from the crown, and a longer portion of the lune acts as an arch, than has been supposed by previous writers on this subject,* none of whom, so far as known, have given a correct process for the solution of the problem, although the results arrived at have been somewhat approximately correct.

To ensure stability, the equilibrium curve must be inscribed within the inner third of that part of the meridian section of the lune which is to act as an arch; as appears from the same reasons which were stated in connection with arches of masonry.

And, further, the hoop compression will vanish at that level of the dome where the equilibrium curve, in departing from the crown, first becomes more nearly vertical than the tangent of the meridian section; for above that point the greatest thrust that the dome can exert, cannot be so great as at this point where the thrust of the arch-lune is equal to that of the dome.

Now to determine in what ratio the ordinates of the curve c must be elongated to give those of the curve e which fulfills the required conditions, we draw the line fo , and cut it at p_1, p_2 , etc. by the horizontals $m_1 p_1, m_2 p_2$, etc., the quantities mb being the ordinates of exterior of the inner third. Again draw verticals through p_1, p_2 , etc., and cut them at $q_1,$

q_2, q_3 , etc. by horizontals through c_1, c_2, c_3 , etc. Through these points draw the curve qq , whose ordinates are of the type qh . Some one of these ordinates is to be elongated to its corresponding ph , and in such a manner that no qh shall then become longer than its corresponding ph . To effect this, draw oq_2 tangent to the curve qq ; then will oq_2 enable us to effect the required elongation: *e.g.* let the horizontal through c_4 cut oq_2 at j_4 , and then the vertical through j_4 cuts fo at i_4 , then is e_4 (which is on the same level with i_4) the new position of c_4 . Similarly, we may find the remaining points of the curve e ; but it is better to determine the new pole distance, and use this method as a test only.

The curve qq made use of in this construction for finding the ratio lines for so elongating the ordinates of the curve c , that the new ordinates shall be those of a curve e tangent to the exterior line of the inner third, may be applied with equal facility to the construction for the arch of masonry. This furnishes us with a direct method in place of the tentative one employed in connection with Fig. 14.

To find the new pole distance, draw $fj \parallel oq_2$ cutting wv at j , then will i the intersection of the horizontal through j , be the new position of the weight line vv , having its pole distance from a diminished in the required ratio.

The equilibrium curve e will be parallel to the curve of the dome at the points where the new weight line vv cuts the curve st . It should be noticed that the pole distance which we have now determined is still a little too large because the polygon e is circumscribed about the true equilibrium curve; and as the polygon has an angle in the limiting curve mm the equilibrium curve is not yet high enough to be tangent to the limiting curve. If the number of divisions had originally been larger (which the size of our Figure did not permit) this matter would be rectified.

The polygon e is seen at e_5 to fall just without the required limits, this would be partly rectified by slightly decreasing the pole distance as just suggested; the point, however, would still remain just without the limit after the pole distance is decreased, and by so much is the dome unstable. A dome of which the thick-

* See a paper read before the Royal Inst. of British Architects, "on the Mathematical Theory of Domes," Feb. 6th, 1871. By Edmund Beckett Denison, L.L.D., Q.C., F.R.A.S.

ness is one fifteenth of the internal diameter, is almost exactly stable.

It is a remarkable fact that a semi-cylindrical arch of uniform thickness and without surcharge must be almost exactly three times as thick, viz., the thickness must be about one fifth the span in order that it may be possible to inscribe the equilibrium curve within the inner third.

The only large hemispherical dome, of which I have the dimensions, which is thick enough to be perfectly stable without extraneous aid such as hoops or ties, is the Gol Goomuz at Beejapore, India. It has an internal diameter of $137\frac{1}{2}$ feet, and a thickness of 10 feet, it being slightly thicker than necessary, but it probably carries a load upon the crown which requires the additional thickness.

The hemispherical dome of uniform thickness is a very faulty arrangement of material. It is only necessary to make the dome so light and thin for $51^{\circ} 49'$ from the crown that it cannot exert so great a horizontal thrust as do the thicker lunes below, to take complete advantage of the real strength of this form of structure. A dome whose thickness gradually decreases toward the crown takes a partial advantage of this, but nothing short of a quite sudden change near this point appears to be completely effective.

The necessary thickness to withstand the hoop compression and the meridian thrust can be found as previously shown in the dome of metal.

Domes are usually crowned with a lantern or pinnacle, whose weight must be first laid off below the pole a after having been reduced to the same unit as that of the zones of the dome.

Likewise when there is an eye, at the crown or below, the weight of the material necessary to fill the eye must be subtracted, so that a is then to be placed below its present position. The construction is then to be completed in the same manner as in Fig. 18.

It is at once seen that the effect of an additional weight, as of a lantern, at the crown, since it moves the point a upward a certain distance, will be to cause the curve st to have all its points except b to the left of their present position, and especially the points in the upper part of the curve, thus making the point of no hoop tension much nearer the crown than

in the metallic dome. It will be noticed that the addition of very small weight at the crown will cause the point m_2 of no hoop tension in the dome of masonry to approach almost to the crown, so that then the lunes will act entirely as stone arches with the exception of a very small segment at the crown.

On the contrary, the removal of a segment at the crown, or the decrease of the thickness, or any device for making the upper part of the dome lighter will remove the point of no hoop tension further from the crown, both for the dome of metal and of masonry. In any dome of masonry the thickness above the point of no hoop tension, as determined by the curve st , need be only such as to withstand the two compressions to which it is subjected, viz; hoop compression and meridian compression: while below that the lunes acting as arches must be thick enough to cause a horizontal thrust equal to the maximum radial thrust of the dome above the point of no hoop tension.

Several large domes are constructed of more than one shell, to give increased security to the tall lanterns surmounting them: St. Peter's, at Rome, is double, and the Pantheon, at Paris, is triple. The different shells should all spring from the same thick zone below the point of no hoop tension; and the lunes of this thick zone should be able to afford a horizontal thrust equal to the sum of the radial thrusts of all the shells standing upon it.

Attention to this will secure the stability in itself of any dome of masonry spherical or otherwise; and, though I here offer no proof of the assertion, I am led to believe that this is the solution of the problem of constructing the dome of a minimum weight of material, on the supposition that the meridian joints can afford no resistance to hoop tension.

Now, in fact, it is a common device to ensure the stability of large domes by encircling them with iron hoops or chains, or by embedding ties in the masonry; and this case appears to be of sufficient importance to demand our attention.

If the hoop encircles the dome at $51^{\circ} 49'$ or any other less distance from the crown the dome will be a true dome at all points above the hoop. Suppose the

hoop to be at $51^\circ 49'$, then the curve e should, below that point, be made to pass through the points f_3 and f_8 , from which it is seen that the dome may be made thinner than at present, and the horizontal thrust caused will be less. The tension of the hoop would be that due to a radial thrust which is the difference between that given by the curve st for this point and the horizontal thrust (pole distance) of the polygon e when it passes through f_3 and f_8 . That the curve e passes through these last mentioned points is a consequence of the principle of least resistance.

Again, suppose another hoop encircles the dome at f_5 ; the curve e must pass through f_8 and f_5 , and in this part of the lune will have a corresponding horizontal thrust. The curve e must also pass through f_5 and f_3 , but in this part of the lune will have a horizontal thrust corresponding to it, differing from that in the part between f_8 and f_5 : indeed the horizontal thrust in the segment of a dome above any hoop depends exclusively upon that segment and is unaffected by the zone below the hoop. The tension sustained by the hoop is, however, due to the radial force, which is the difference of the horizontal thrusts of the zones above and below the hoop.

It is seen that the introduction of a second hoop will still further diminish the thickness of lune necessary to sustain the dome, unless indeed the thickness is required to sustain the meridian compression.

Had a single hoop been introduced at f_5 with none above that point, the dome above f_5 should then be investigated, just as if the springing circle was situated at that point. The curve e must then start from f_5 , as it before did from f_8 , and be made to become tangent to the limiting curve at some point between f_5 and the crown.

By the method here employed for finding the tension of a hoop it is possible to discuss at once the stresses induced in the important modern domes constructed with rings and ribs of metal and having the intermediate panels closed with glass.

On introducing a large number of rings at small distances from each other, it will be seen that the discussion just

given leads to the method previously given for the dome of metal.

The dome of St. Paul's, London, is one which has excited much adverse criticism by reason of the novel means employed to overcome the difficulties inherent in so large a dome at so great a height above the foundations of the building. The exterior dome consists of a framework of oak sustained by conical dome of brick which forms the core. There is also a parabolic brick dome under the cone which forms no essential part of the system. Since the conical dome in general presents some peculiarities worthy of notice we will give an investigation of that form of structure as our concluding construction.

CHAPTER XVII.

CONICAL DOME OF METAL.

In Fig. 19, let bd be the axis of the frustum of a metallic cone cut by a vertical plane in the meridian section a . The cone is supposed to have a uniform thickness too small to be regarded in comparison with its other dimensions. Suppose the frustum to be cut by a series of equi-distant horizontal planes as at g_1, g_2 , etc., into a series of frustra or rings: then the weight of each ring is proportional to its convex surface. The convex surface of any ring $= 2\pi r \times$ slant height; when r is half the sum of the radii of the two bases, *i.e.*, r is the mean radius. Consequently, the weights of these rings, or any given fraction of them included between two meridian planes, is proportional to their mean radii. Let us draw these mean radii d_1a_1, d_2a_2 , etc., between the horizontals through g_1, g_2 , etc., and use some convenient fraction, say $\frac{1}{3}$, of these quantities of the type du as the weights. The line ii cuts off $\frac{1}{3}$ of each of these: then lay off $du_1 = d_1i_1$ as the weight of the ring ag_1 , lay off $u_1u_2 = d_2i_2$, $u_2u_3 = d_3i_3$, etc., as the weights of the rings g_1g_2, g_2g_3 , etc.

Draw the line $dt \parallel aa$, it corresponds to the curve st of Fig. 18; then the quantities of the type tu represent the horizontal radial thrust which the cone exerts upon the part below it, while the radial thrust borne by any ring is the difference between two successive quantities of the type tu , *i.e.*, the radial thrust in the ring g_1g_2 is represented by t_2y_2 ,

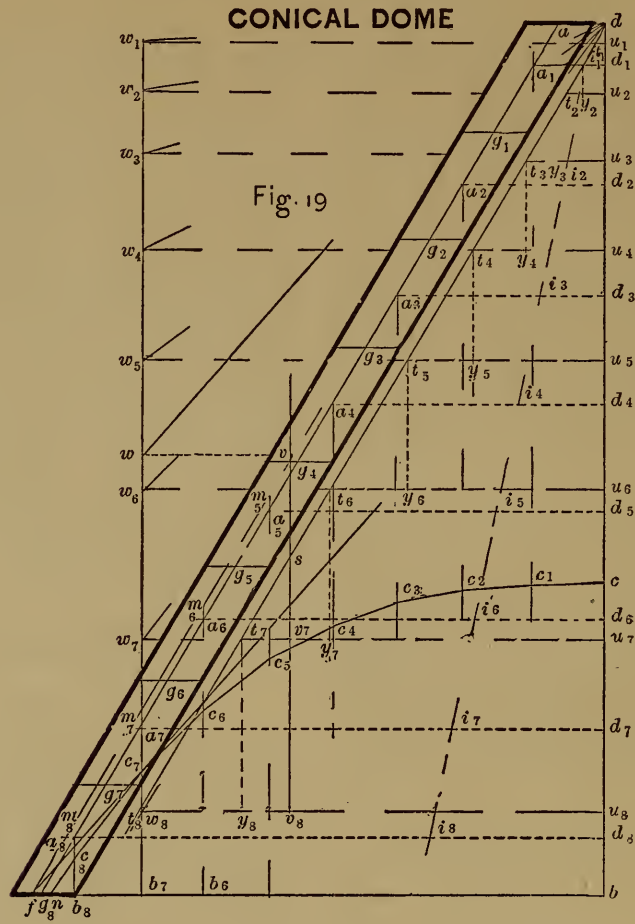

that in g_6g_7 by t_7y_7 , etc. As previously shown in connection with the spherical dome, if the scale of weights be such that du_8 represents a part of the cone between two meridian planes which make an angle of $\theta = 180^\circ \div \pi = 57^\circ.3$, then will t_8y_8 , t_7y_7 etc., be the total hoop compression of the corresponding rings of the cone. It is to be noticed that this quantity does not change sign in the cone, and is always compression.

The meridian compression is expressed, under the same circumstances by the quantities dt_8 , dt_7 , etc.

Such a cone as this must be placed upon a cylindrical drum or other support which can exert a resistance in the direction aa , but if this support is very slightly displaced by the horizontal radial thrust, a hoop tension will be induced at the base of the cone. As this displacement is very likely to occur it is far better to have the base of the cone sufficiently strong to withstand this tension, which is t_8u_8 when du_8 is the weight of $57^\circ.3$: then the supports will sustain a vertical force alone.

This discussion applies equally well to

a cone formed of a network of rings and inclined posts with intermediate panels of glass or other material.

CONICAL DOME OF MASONRY.

Let us assume that the uniform horizontal thickness of the dome to be treated, is one sixteenth of the internal diameter of the base, or one eighth of the internal radius, as shown in Fig. 19. The actual thickness is less than this, but since the horizontal thickness is a convenient quantity, we shall call it the thickness unless otherwise specified.

Pass equidistant horizontal planes as previously stated: then the volumes of these rings may be found by the prismoidal formula. The volume

$$= \frac{1}{6} \pi h [r_1^2 - r_1'^2 + 4(r^2 - r'^2) + r_2^2 - r_2'^2],$$

in which h is the height of the ring, r_1 and r_1' are the radii external and internal of one base, r_2 and r_2' of the other, and r and r' of the middle section. Now $r_1 - r_1' = r - r' = r_2 - r_2' = t$ the thickness of the cone; and

$$r_1 + r_2 = 2r, \quad r_1' + r_2' = 2r'$$

$$\therefore \text{Volume} = \pi h t (r + r') = 2\pi h t \bar{r}$$

when $\frac{1}{2}(r + r') = \bar{r}$ the mean radius of the middle section. From this it is seen that the weights vary in the same manner, and are represented by the same quantities as previously stated in case of a thin cone. Assume that the centers of gravity of any thin lunes cut from these rings by meridian planes making a small angle with each other, are at the middle points a_s, a_r , etc., this assumption is sufficiently exact for the part of the cone near the base, which we are now specially to investigate.

By means of the weights $w_s w_r = u_s u_r$, etc., at some assumed distance from the pole d , describe the equilibrium polygon c , starting from n at the inner third of the base.

Now if the cone stands upon a drum which necessarily exerts a sufficient radial thrust to keep the meridian joints of the cone closed down to the base, then all the circumstances will be precisely as before explained in respect to the metallic dome: but if the drum exerts a less radial thrust, the meridian joints will open near the base, and the conditions of stability of that part of the cone will need to be investigated, as was done in the spherical dome of masonry, by considering the upper part of the dome as sustained by a series of stone arches. From f draw fc_r tangent to the curve c ; then must $c_r b_r$ be elongated to $m_r b_r$ and the other ordinates of c must be elongated in the same ratio in order that the equilibrium polygon may be tangent to the exterior limit fm ; and, further, fm and fc_r are the ratio lines by which to effect the elongation. To find how much the thrust is diminished, draw through the intersection of fm with bd , a line parallel to fc_r , intersecting the weight line at w , and then v the point where the horizontal through w intersects fm gives us the new position of the weight line, and its distance from the pole d . This vertical intersects tt about midway between t_s and t_r , thus showing that the meridian joints of the cone will be open from the base to about the point g_s . It is unnecessary to draw the equilibrium polygon in its new position.

We thus obtain the least horizontal thrust against which the dome can stand.

The actual thrust which the drum exerts may have any value greater than this least thrust.

It is seen that the effect of diminishing the thickness of the cone, is to carry the tangent point c_r and the point of no compression nearer to the base. In other words the thin dome of masonry of given semi-vertical angle necessarily exerts a greater thrust in proportion to its weight than does a thick dome, though that proportion is unchanged if the joints are to remain closed all the way to the base.

All of the circumstances respecting radial thrust above the point of no hoop compression, and respecting meridian thrust, are the same as in the metallic cone.

Any additional loading above that of the weight of the cone itself, as for example, the weight of a lantern, or of an external dome, as in the case of St. Paul's, can be introduced and treated as an additional height or thickness of certain rings of the cone. The same method which has been here applied may be applied to all such cases, if the weights be determined by some suitable process. For example, it may be shown by the help of the prismoidal formula, that the volume of the ring cut from a uniformly tapering cone by equidistant horizontal planes, varies as the product of the mean radius of the mid-section by the thickness at the mid-section.

OTHER VAULTED STRUCTURES.

Similar principles to those above developed apply to domes with an elliptical or polygonal base, to domes whose meridian sections are ogee curves, to Skew Arches, to Groined Arches formed by the combination of cylindrical arches, as well as to Groined Arches which are dome-shaped.

By the application of the principles developed it is easy to treat the cone or dome which sustains the pressure of earth or water. Indeed, it is not too much to say that the complete solution of the problem of the stability of vaulted structures has now been set forth for the first time, and that the proper connection and relationship between similar structures, in metal and masonry, may now be clearly seen. In particular, the discus-

sions have made manifest the applicability of a particular equilibrium polygon among the infinite number which are due to a given set of weights, and which are all projections of any one of them, and the possibility of deriving from it in each of the structures treated, a complete and sufficiently exact solution.

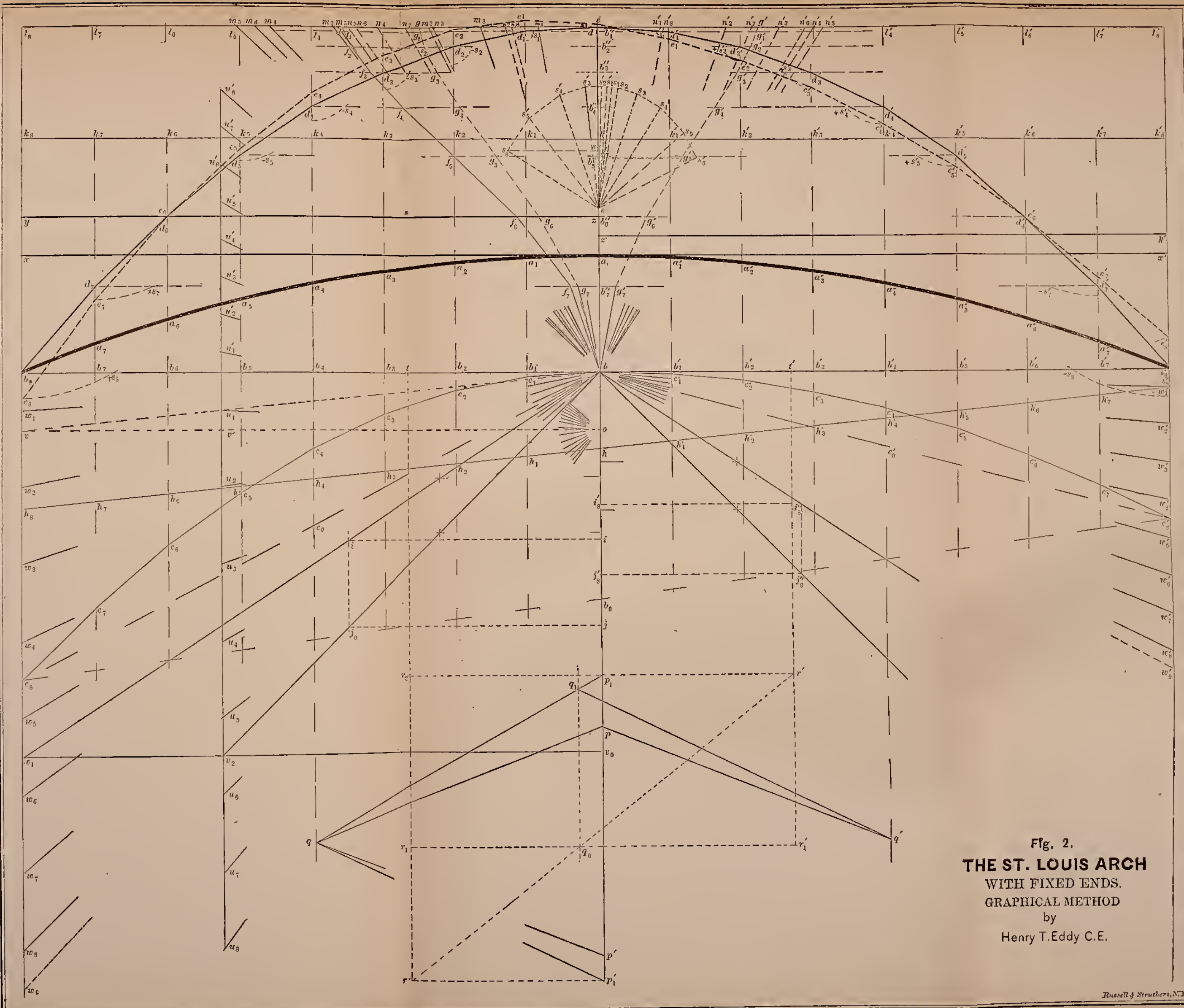

Fig. 2.
THE ST. LOUIS ARCH
 WITH FIXED ENDS.
 GRAPHICAL METHOD
 by
 Henry T. Eddy C.E.

sions
ity c
amoi
due :

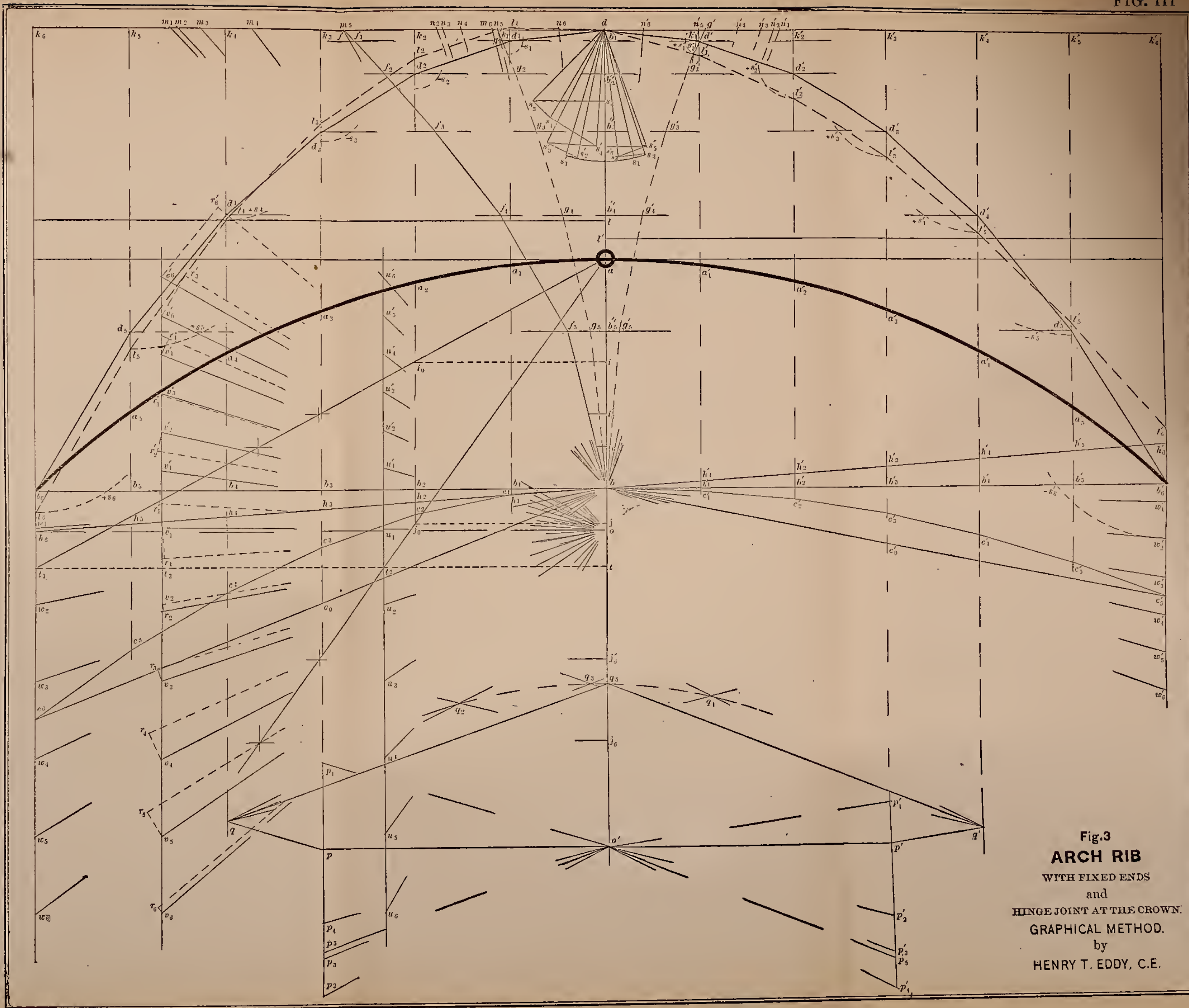
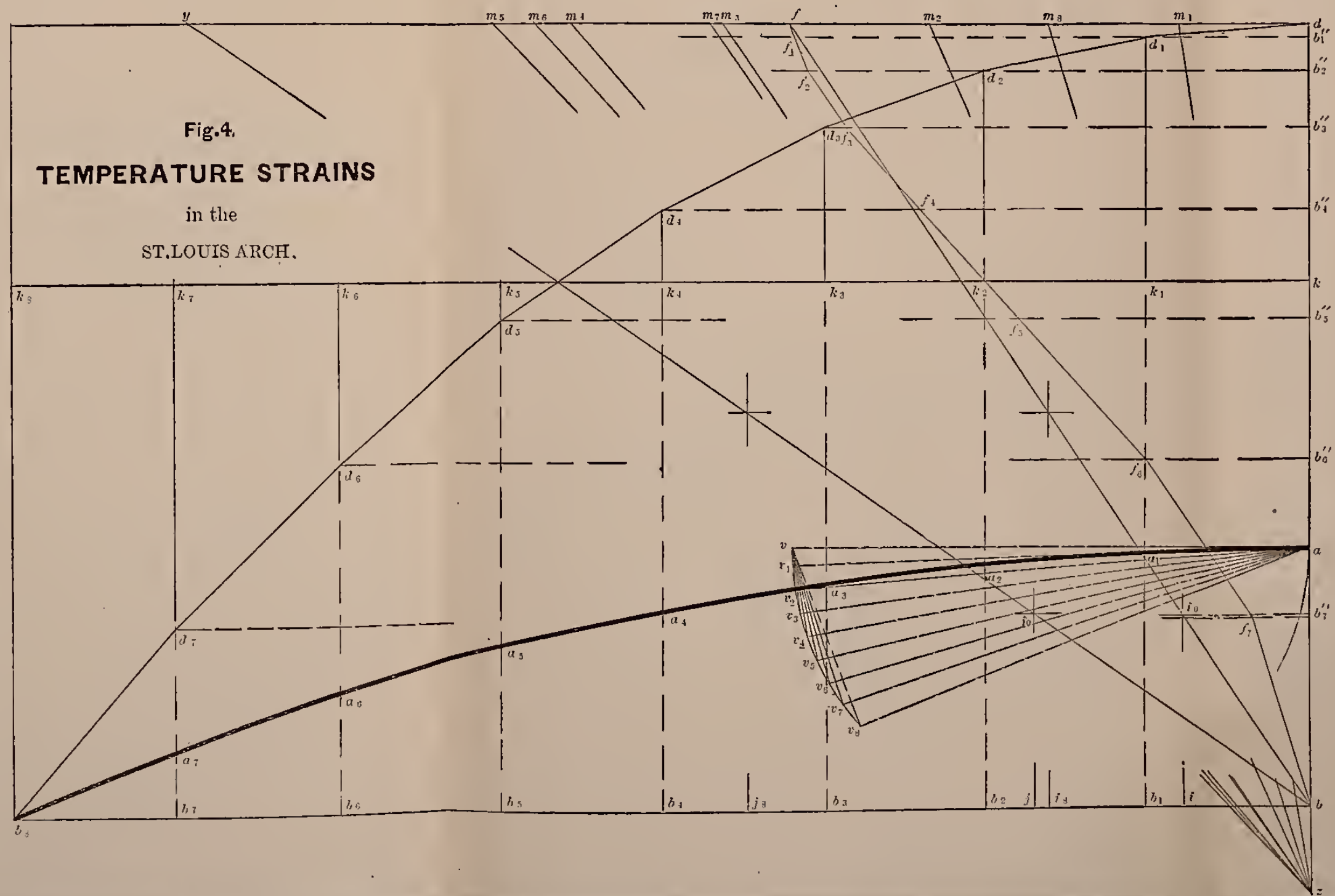

Fig.3
ARCH RIB
WITH FIXED ENDS
and
HINGE JOINT AT THE CROWN.
GRAPHICAL METHOD.
by
HENRY T. EDDY, C.E.

sion
ity
amc
due

FIG. IV.



—
sion
ity
amc
due

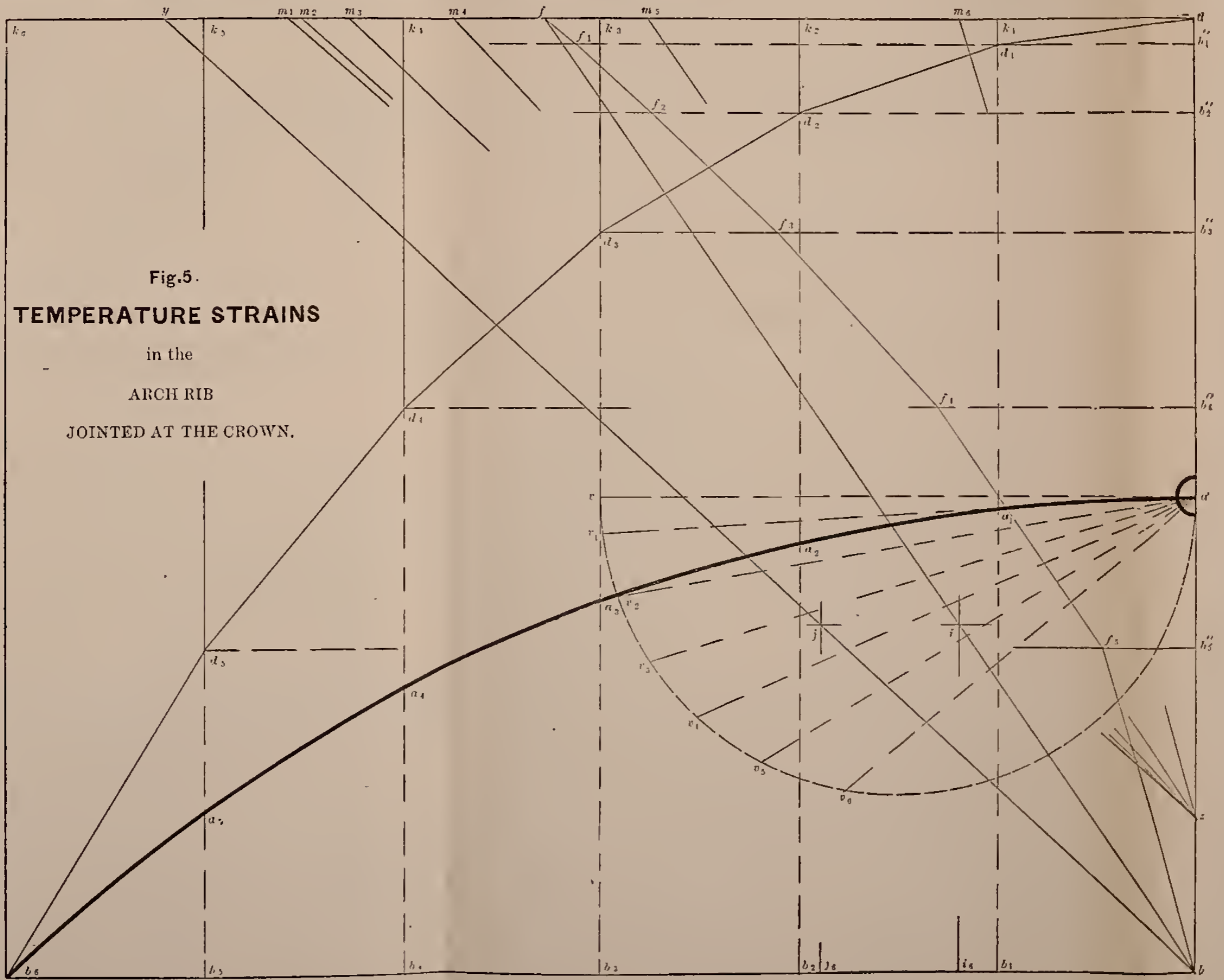

Fig.5.
TEMPERATURE STRAINS
 in the
 ARCH RIB
 JOINTED AT THE CROWN.

6:
—
si
it
an
d

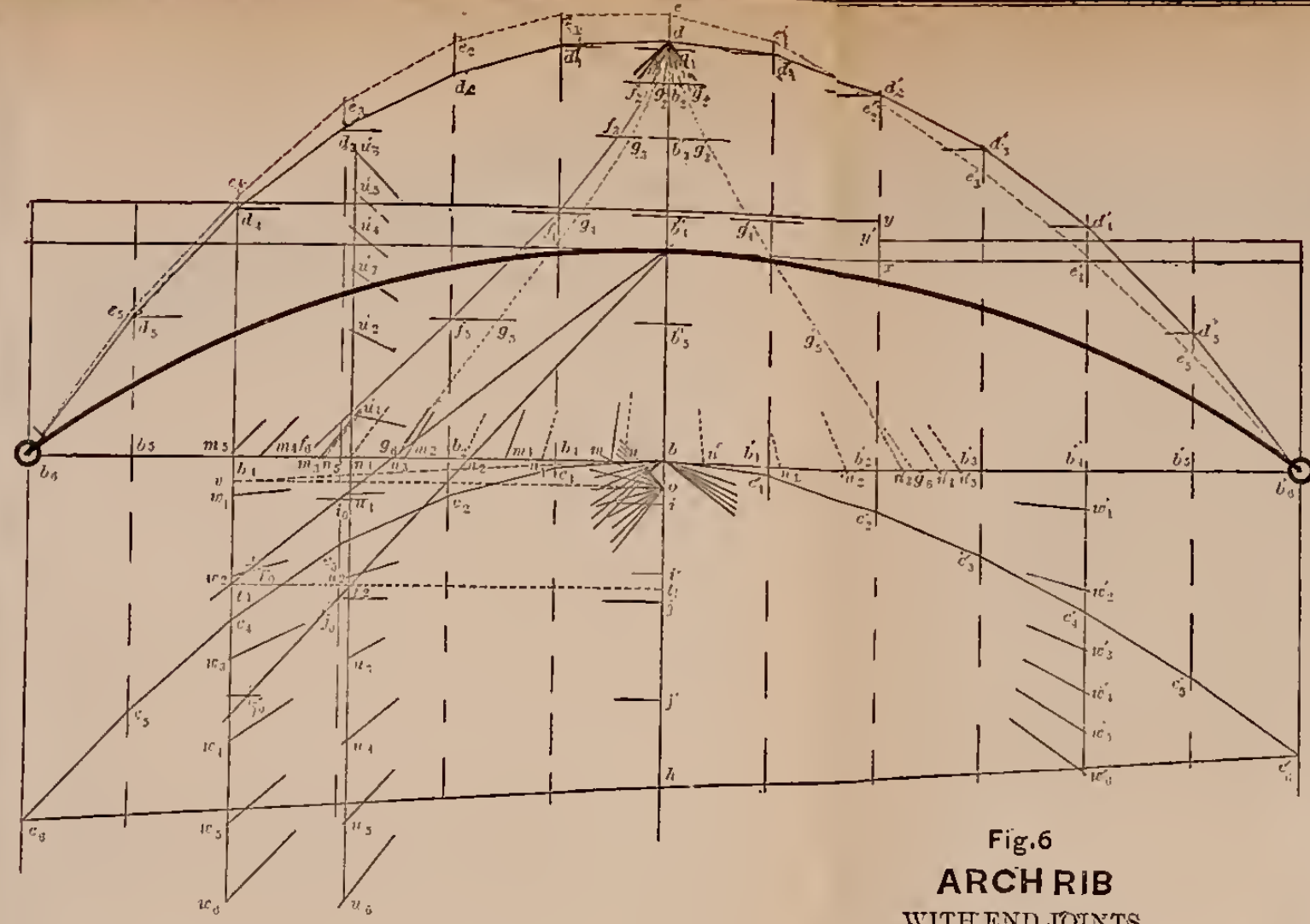

Fig.6
ARCH RIB
WITH END JOINTS.
GRAPHICAL METHOD.

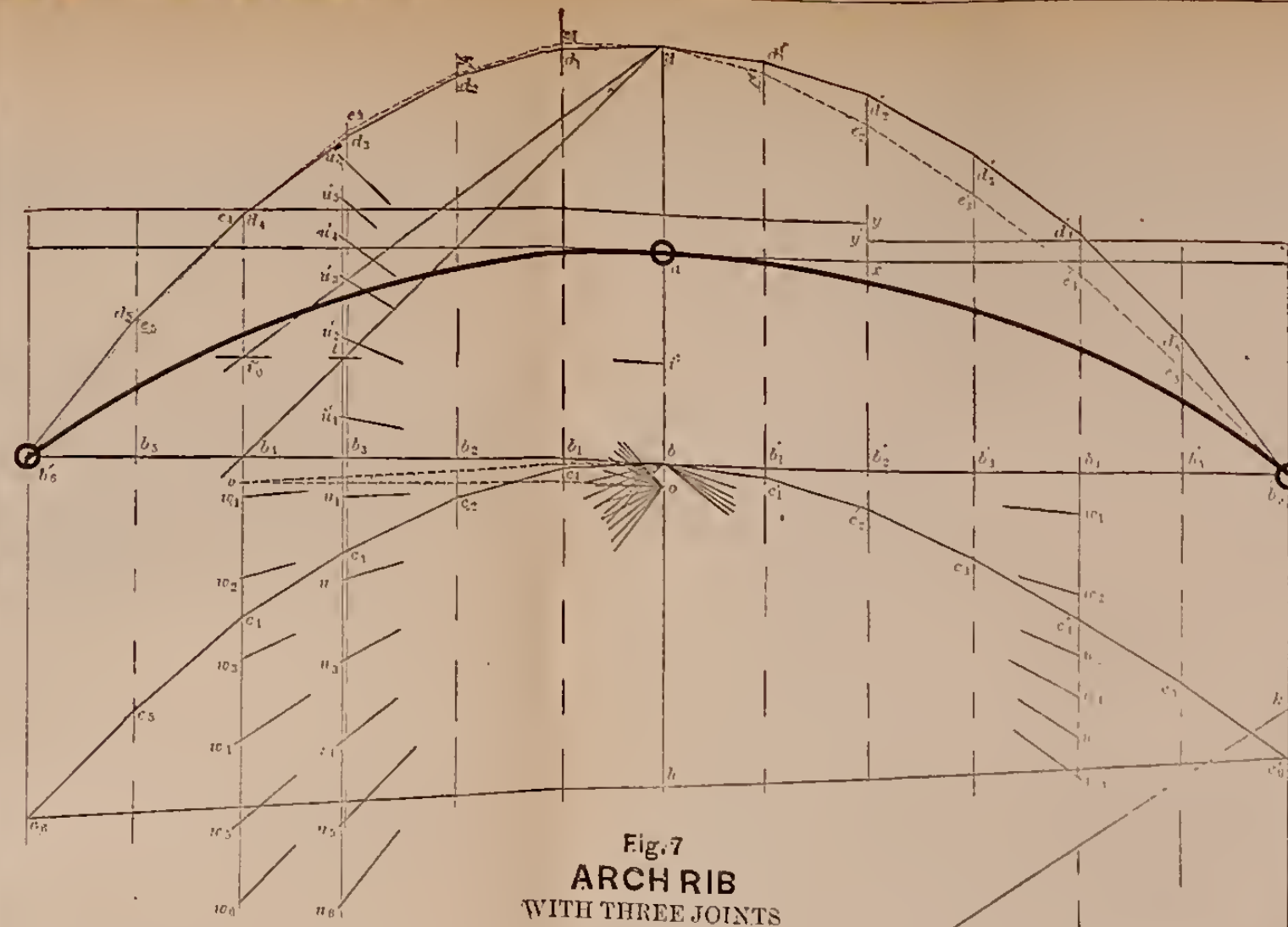

Fig.7
ARCH RIB
WITH THREE JOINTS
GRAPHICAL METHOD.

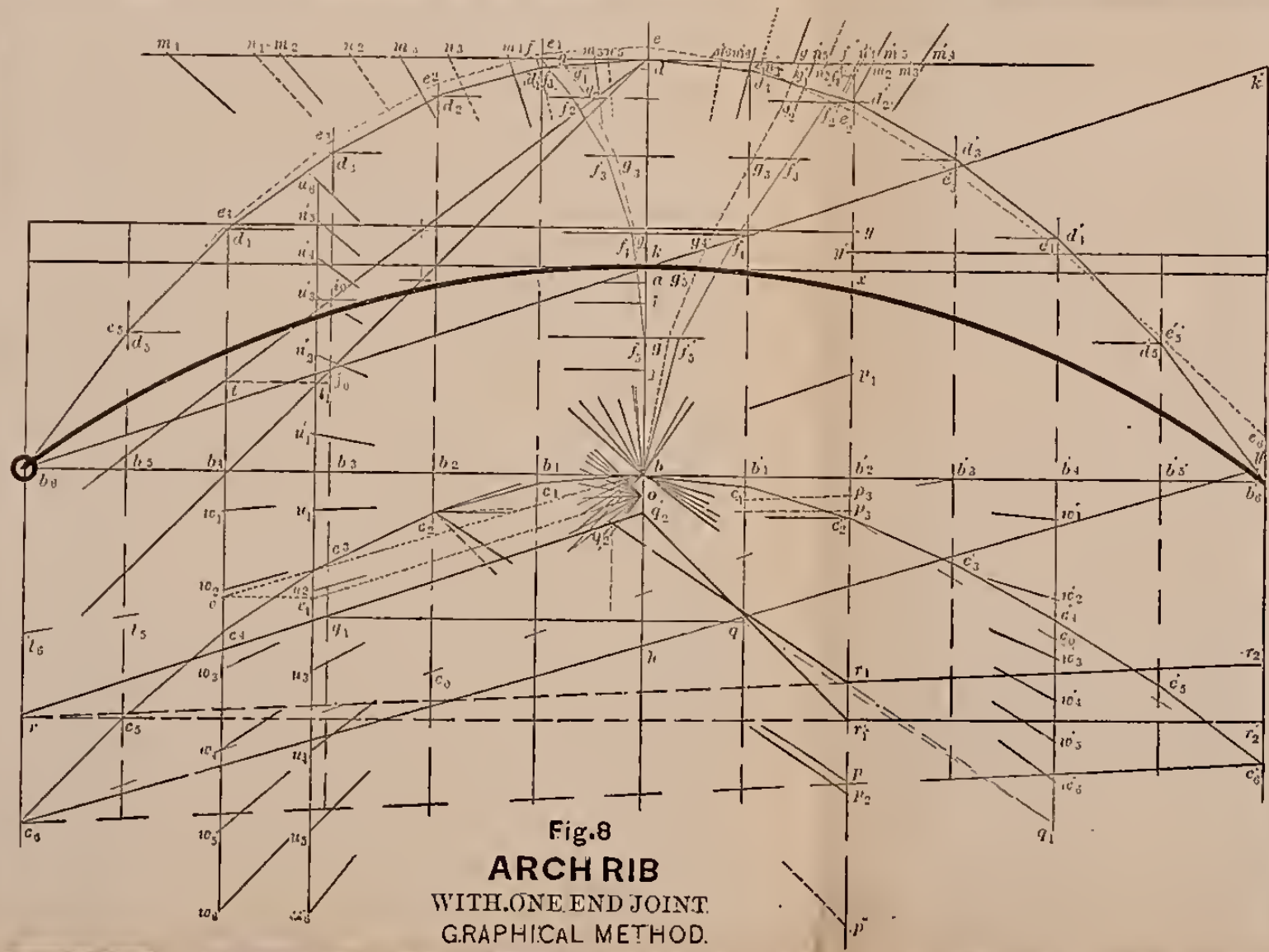

Fig.8
ARCH RIB
WITH ONE END JOINT.
GRAPHICAL METHOD.

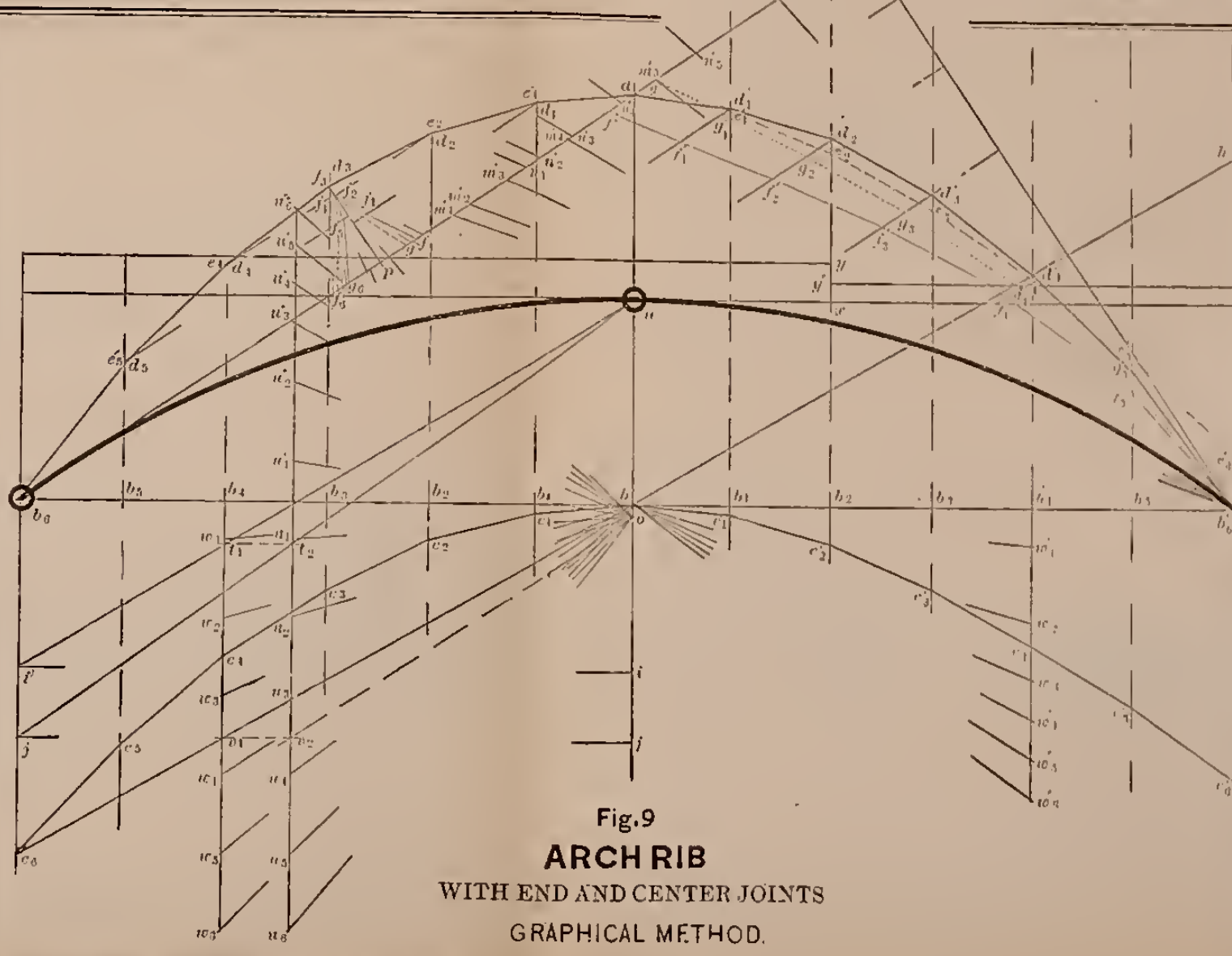

Fig.9
ARCH RIB
WITH END AND CENTER JOINTS
GRAPHICAL METHOD.



3.

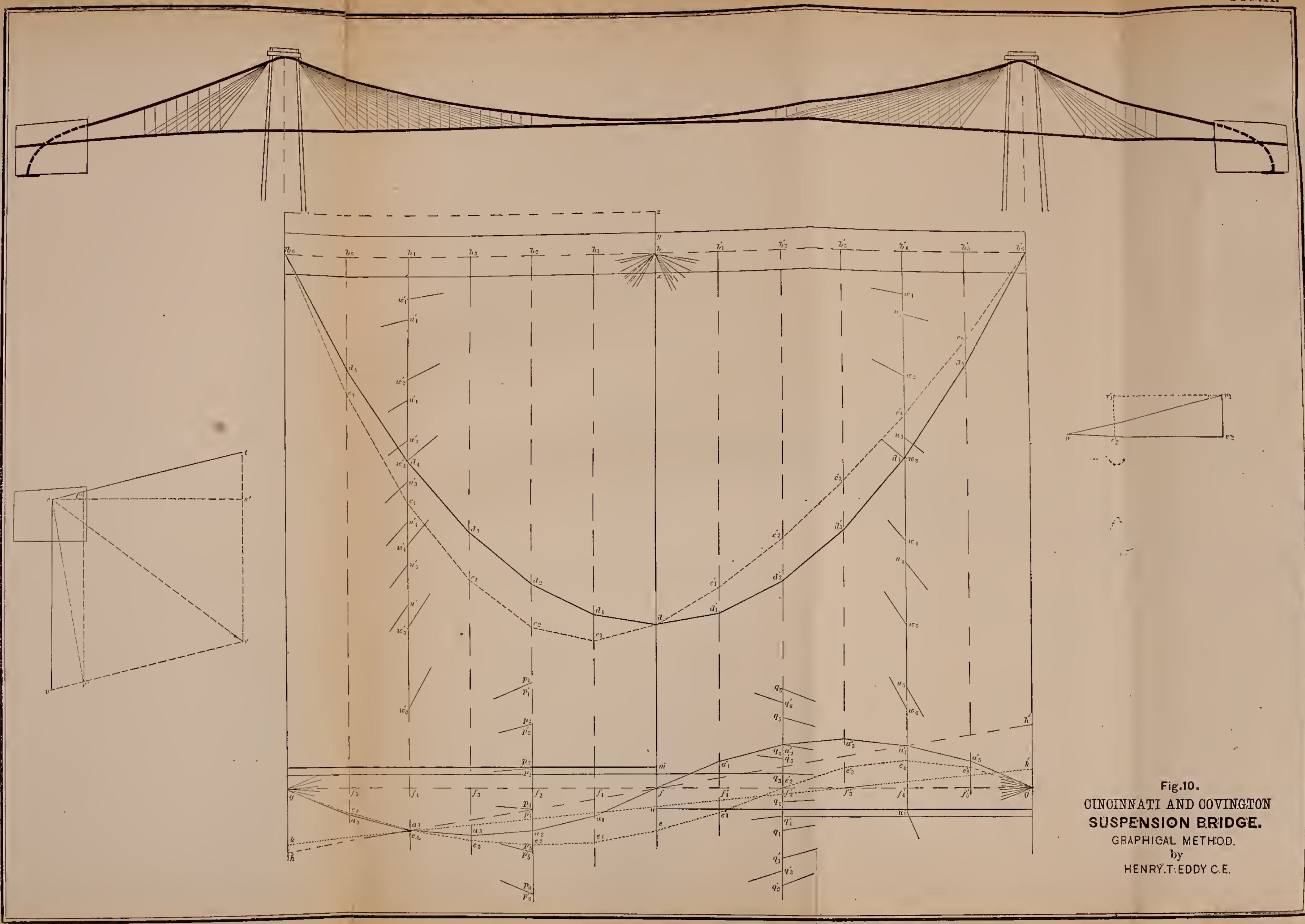
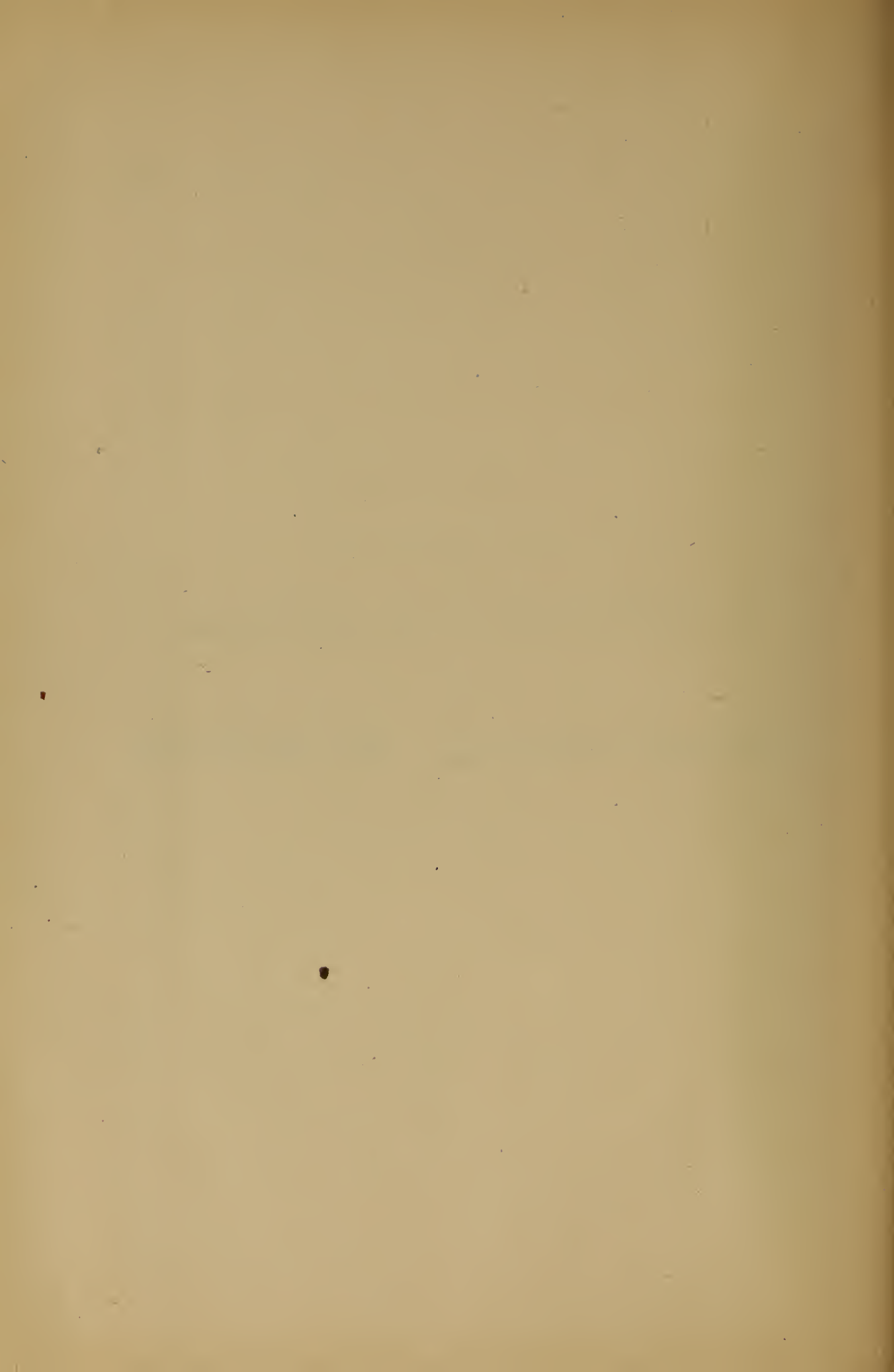

Fig.10.
 CINCINNATI AND COVINGTON
 SUSPENSION BRIDGE.
 GRAPHICAL METHOD.
 by
 HENRY T. EDDY C.E.

A NEW GENERAL METHOD
IN
GRAPHICAL STATISTICS.



A NEW GENERAL METHOD

IN

GRAPHICAL STATICS.

ALL general processes used in the graphical computation of statical problems consist, in their last analysis, in a systematized application of the proposition known as the "parallelogram of forces," which states that if two forces be applied to a material point, and if they be represented in magnitude and direction by two determinate straight lines, then their resultant is represented in magnitude and direction by the diagonal of a parallelogram, two of whose sides are the just mentioned determinate lines. This is the basis of all grapho-statical construction, but the methods by which it is systematized, and the auxiliary ideas incorporated in the processes, have so enlarged its possibilities of usefulness, that Graphical Statics may perhaps claim to be a science of itself;—the science of the geometrical treatment of force.

In order to introduce to the public a new set of auxiliary ideas, which shall constitute a new method, of a character equally general with that now in use and known as the "equilibrium polygon method," it has seemed best to give, in the first place, a brief review of the principal ideas already employed by the cultivators of this science.

RECIPROCAL FIGURES.

When a framed structure, such as a roof or bridge truss, is subjected to the action of certain weights or forces, these applied forces form a system which is in

equilibrium. Now any system of forces in equilibrium may be represented in magnitude and direction by the sides of a closed polygon, a fact which follows at once from the doctrine of the parallelogram of forces. Such a polygon is called the polygon of the applied forces.

Again, the forces which act at any joint of a frame are in equilibrium, and hence there is a closed polygon of the forces acting at each joint. The forces which meet at a joint of a frame are the longitudinal tensions or compressions of the pieces meeting at that joint, together with any of the applied forces whose point of application may be the joint in question. Draw a diagram of the frame and the applied forces all of which we will suppose lie in a single plane. Call this the "frame diagram:" it represents the position and direction of all the forces acting in and upon the frame. The frame diagram necessarily has at least three lines meeting at each joint. A piece which constitutes part of the frame does not necessarily have both its extremities attached at joints of the frame; one extremity may be firmly attached to any immovable object. The frame diagram is, therefore, not necessarily made up of closed figures.

Now draw the closed polygon of the forces applied to the frame, and at each of the joints where forces are applied draw the closed polygon of the forces which meet at that joint, using so far as possible the lines already drawn as sides

of the new polygons, and at the same time draw polygons for the forces acting at each of the remaining joints. If this process be effected with care as to the order of procedure, as well as to the order in which the forces follow each other in the polygon of the applied forces, then the resulting "diagram of forces," which is formed of the combination of the polygon of the applied forces with the polygons for each joint, will contain in it a single line and no more parallel to each line of the frame diagram. In that case the force diagram is said to be a reciprocal figure to the frame diagram. If sufficient care is not exercised in the particulars mentioned some of the lines in the force diagram will have to be repeated, and the figure drawn will not be the reciprocal of the frame diagram, nevertheless it will give a correct construction of the quantities sought.

If the frame diagram and the force diagram are both closed figures then they are mutually reciprocal. The properties of reciprocal figures were clearly set forth by Professor James Clerk Maxwell, in the *Philosophical*

Magazine, vol. 27, 1864; in which is stated, what is also evident from considerations already adduced above, that mutually "reciprocal figures are mechanically reciprocal; that is, either may be taken as representing a system of points (*i.e.* joints) and the other as representing the magnitudes of the forces acting between them."

The subject has also been treated by Professor B. Cremona in a memoir entitled "Le figure reciproche nelle statica grafica." Milan, 1872.

We shall now give examples of this method of computing the forces acting between the joints of a frame, together with certain extensions by which we are enabled to treat moving loads, etc. The method is correctly called "Clerk Maxwell's Method." The notation employed, which is particularly suitable for the treatment of reciprocal diagrams, is due to R. H. Bow, C.E.; and is used by him in his work entitled "Economics of Construction." London, 1873. In this work will be found a very large number of frame and force diagrams drawn by this method.

Let the right hand part of Fig. 1

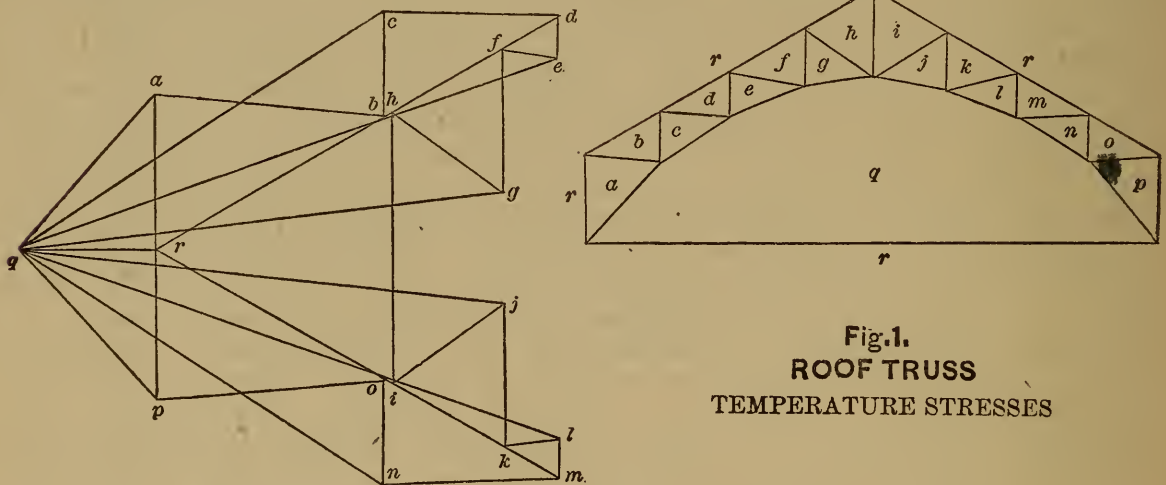

Fig.1.
ROOF TRUSS
TEMPERATURE STRESSES

represent a roof truss having an inclination of 30° to the horizon, of which the lower chord is a polygon inscribed in an arc of 60° of a circle. If the lower extremities of the truss abut against immovable walls a change of temperature causes an horizontal force between these lower joints, the effect of which upon the different pieces of the truss is to be constructed. No other weights or forces are now considered except those due to this horizontal force.

This force is considered thus apart from all others because it is a force between two joints, and must enable us to obtain a pair of mutually reciprocal figures, such as weights and other applied forces seldom give.

It is seen that the force between these joints might be supposed to be caused by a tie joining these points; and in general it may be stated that the diagram of forces due to any cambering or stress induced in a frame by "keying"

pieces, is mutually reciprocal to the frame diagram.

Let any piece of the frame be denoted by the letters in the spaces on each side of it; thus the pieces of the lower chord are qa , qc , qe , etc.; and those of the upper chord are rb , rd , etc., while ab , bc , etc., are pieces of the bracing, and qr is the tie whose tension produces the stress under consideration.

In the force diagram upon the left, let qr represent, on some assumed scale of tons to the inch, the tension in the piece qr ; and complete the triangle aqr with its sides parallel to the pieces which converge to the joint aqr ; then must this triangle represent the forces which are in equilibrium at that joint. Next, with ar as one side, complete the triangle abr , by making its sides parallel to the pieces meeting at the joint of the same name:—its sides will represent the forces in equilibrium at that joint. In a similar manner we proceed from joint to joint, using the stresses already obtained in determining those at the successive joints.

It is not possible to determine in general more than two unknown stresses in passing to a new joint, unless aided by some considerations of symmetry which may exist at such a joint as $ghijq$.

Now from the left hand figure as a frame diagram, in which stresses are induced by causing tension in the tie qr , we can construct the right hand figure as a force diagram, but it must be noticed in that case that rb , rh , rf , rd are separate and distinct pieces meeting at the joint r , although they all lie in the same right line, and that the same is true along the line $oikm$.

One or two considerations of a general nature should be recalled in this connection.

A polygon encloses the space q ; in the reciprocal figure the lines parallel to its sides must all diverge from the point q : and if the upper chord had been a polygon, instead of being of uniform slope, the lines parallel to its sides would diverge from the point r . As it is, ra , rb , rd , rm etc., form the rays of such a pencil, in which several rays are superposed one upon another.

The determination of the question as to whether the stress in a given piece is tension or compression is

effected by following the polygon for any joint completely around and noting whether the forces act toward or from the joint: *e.g.* at the point $fghrf$, from following the diagrams of preceding joints in the manner stated, it will be found that fg is under tension, and acts from the joint; consequently, gh which acts toward the joint is under compression, as are also the two remaining pieces. Hence if the tension in the tie qr be replaced by an equal compression in a part, tending to move the lower extremities of the roof from each other, the sign of every stress in the roof will be changed, but the numerical amount will remain unchanged, and no change will be made in the force diagram.

ROOF TRUSS.

As another example let us take a roof truss represented in Fig. 2, acted upon by the equal weights fe , ed , dd' , etc. Suppose that the effect of the wind against the right hand side of the truss is such as to cause a deviation of the force applied at the joint $a'b'e'f'$ of the amount indicated in the figure. Such a deviation may of course occur at several joints of a roof, but the treatment of the single joint at which the force of the wind is, in this case, principally concentrated, will sufficiently indicate the method to be employed in more intricate examples.

Suppose that this pressure of the wind is sustained by the left abutment. The manner in which it is really sustained depends upon the method by which the roof is fixed to the walls.

This horizontal pressure of the wind is not directly opposed to the thrust of the left abutment, consequently a couple is brought into play by these forces, whose effect is to transfer a part of the weight from the right to the left abutment. To compute the amount of this effect, draw an horizontal line through this joint (or in case the wind acts at several joints the horizontal line has to be drawn through the center of action of the wind pressure) and prolong it until it intersects the vertical at the right abutment at 3. Let 14 be equal to the pressure of the wind. Join 13 and prolong 13 until it intersects the vertical through 4 at 5, then is 45 the amount by which the weight upon the left abutment is increased, and that

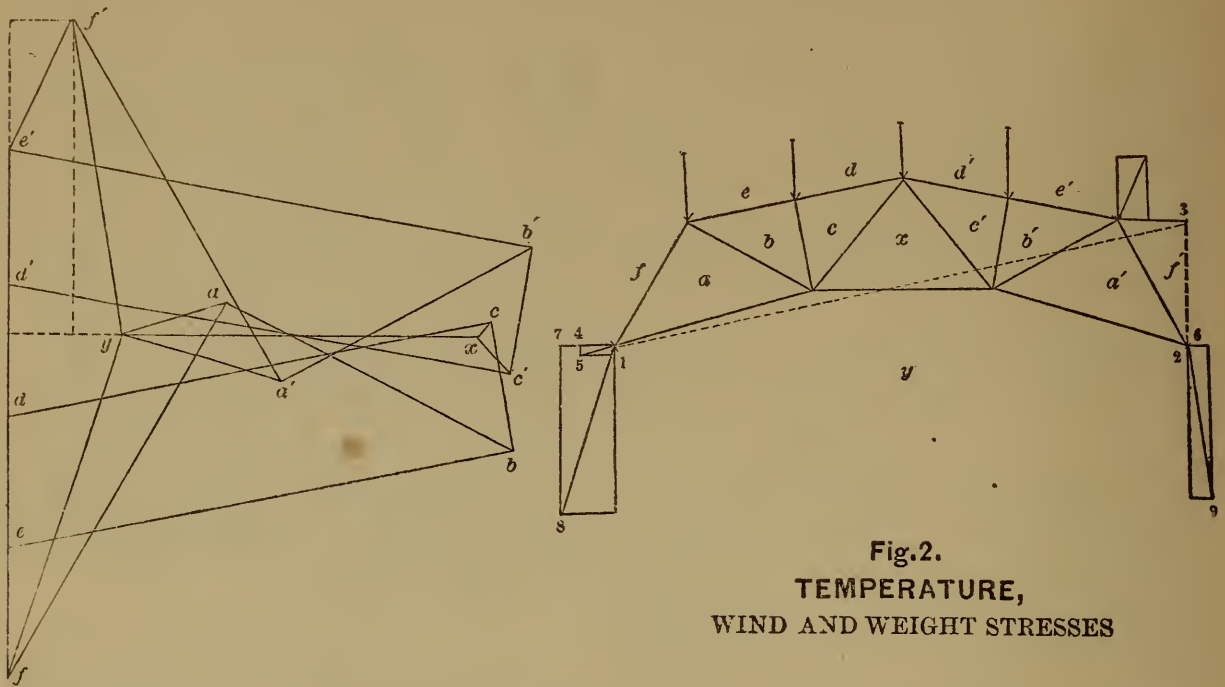

Fig. 2.
TEMPERATURE,
WIND AND WEIGHT STRESSES

upon the left abutment decreased. For, let $k. \overline{14} = \overline{12}$. then $k. \overline{45} = \overline{23}$. Now the couple due to the wind $= \overline{23} \cdot \overline{14}$ but $k. \overline{23} \cdot \overline{14} = \overline{12} \cdot \overline{23} = k. \overline{12} \cdot \overline{45}$, $\therefore \overline{23} \cdot \overline{14} = \overline{12} \cdot \overline{45}$. The right hand side of this last equation is the couple equivalent to the wind couple, having the arm 12 and a pair of equal and opposite forces represented by 45. Let 45 be added to half the weight of the symmetrical loading upon the roof to obtain the vertical reaction of the left abutment, and subtracted from the same quantity for the vertical reaction of the right abutment.

If any doubt occurs as to the manner in which the wind pressure is distributed between the abutments that distribution should be adopted which will cause the greatest stresses upon the pieces, or, as it may be stated in better terms, each piece should be proportioned to bear the greatest stress which any distribution of that pressure can cause.

Let us suppose that a horizontal compression is exerted upon the truss due to temperature or other cause, and represented by the width 26 of the rectangle at the right abutment, then the reaction at that point is the resultant 92 of this compression and the vertical reaction; while at the left abutment the total horizontal reaction 71 is the sum of this compression and the resistance called into action by the wind, giving 81 as the resultant reaction at the left abutment.

Now, using a scale of force twice that just employed, for the sake of greater convenience and accuracy, construct $defyf'e'd'$ the polygon of the applied forces; and proceed to construct as in Fig. 1 the polygons of forces for each of the joints. The accuracy of the construction will be tested by the closing of the figure at the completion of the process.

The force diagram at the left is the reciprocal figure of the diagram of the frame and applied forces at the right, but the figure at the right is not the reciprocal of that at the left since it is not a closed figure with at least three lines meeting at each intersection.

BRIDGE TRUSS.

As a further example take the bridge truss shown in Fig. 3, which is represented as of disproportionate depth in order to fit the diagram to the size of the page. The method employed is a simplification of that given by Mr. Charles H. Tutton on page 385, vol. XVII of this Magazine.

Let us suppose the dead load of the bridge itself to consist of a series of equal weights w , applied at the upper joints x_1, x_2 , etc., of the bridge. Let each of these weights when laid off to scale be represented by the length of $zy''' = w$, then the horizontal lines xx and $y'''o$ include between them ordinates which represent these weights.

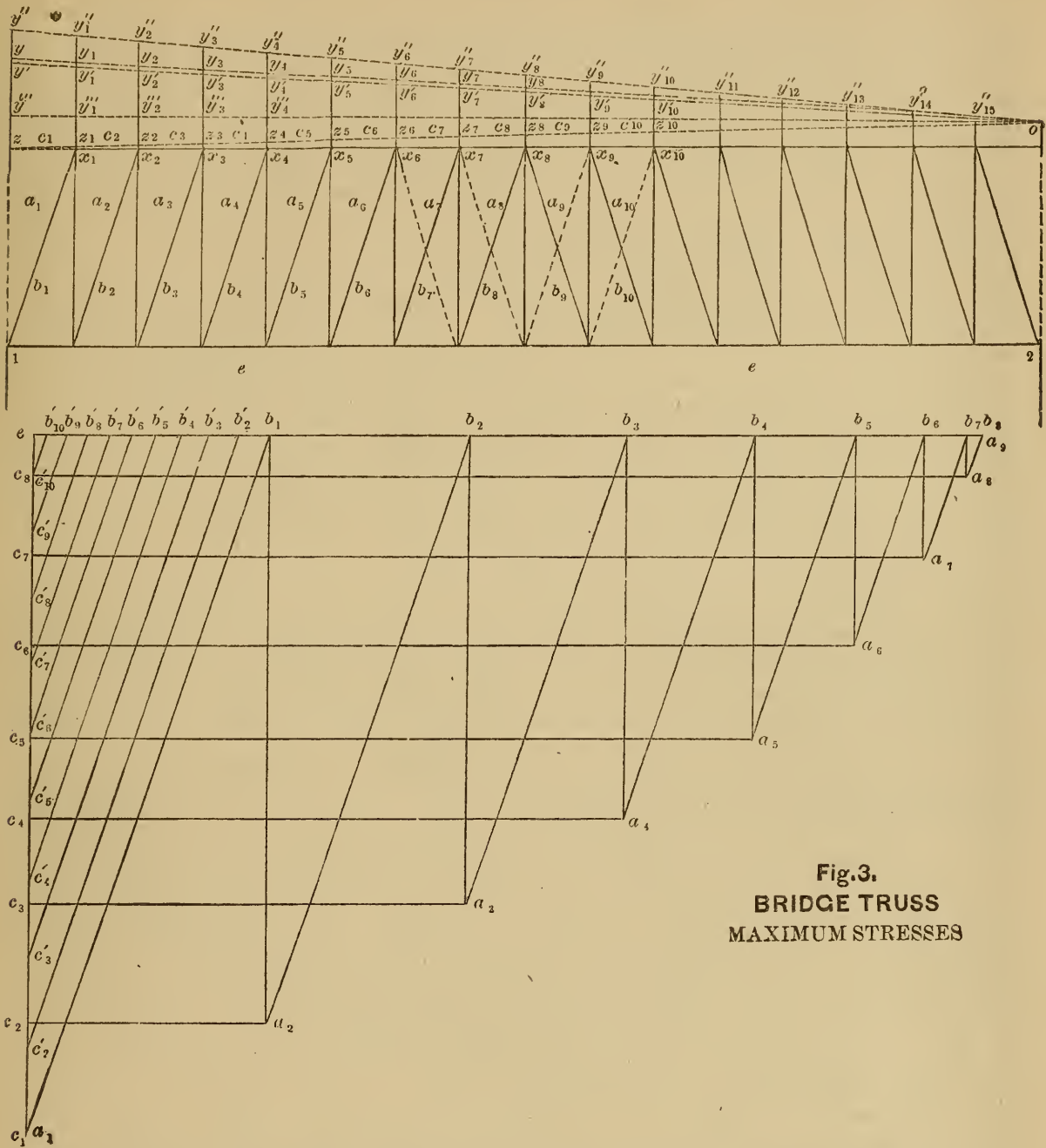

Fig. 3.
BRIDGE TRUSS
MAXIMUM STRESSES

Let the live load consist of one or more locomotives which stand at the joints x_1 and x_2 , and a uniform train of cars which covers the remaining joints. Let the load at each joint due to the cars be represented by $y''y' = w'$, and the excess above this of the load at each of the joints covered by the locomotives be represented by $y'y'' = w''$, $\therefore w + w' + w'' = c_1c_2 = zy'' = c_2c_3$ is the load at x_1 and at x_2 , and $w + w' = c_3c_4 = zy'$ is the load at x_3 and at each of the remaining joints.

Draw $y'o$, $y''o$ and zo , then is $z_1y_1'' = \frac{15}{16}zy''$ that part of the load at x_1 which is sustained at the left abutment, as appears from the principle of the lever. Again $z_2y_2'' = \frac{14}{16}zy''$ is that part

of the load at x_2 sustained by the same abutment, and $z_3y_3' = \frac{13}{16}zy'$ is a similar part of load at x_3 . Let the sum of these weights sustained by the left abutment be obtained; it is c_1e upon the lower figure. Upon c_1e lay off $c_1c_2 = w + w' + w''$, $c_2c_3 = w + w' + w''$, $c_3c_4 = w + w'$, etc., equal to the loads applied at x_1, x_2 , etc. We are now prepared to construct a diagram of forces which shall give the stresses in the various pieces under this assumed loading. Before constructing such a diagram, we wish to show that the assumed position of the load causes greater stresses in the chords of the bridge than any other possible position. The demonstration is quoted nearly ver-

batim from Rankine's Applied Mechanics, and though not strictly applicable to the case in hand, since it refers to a uniformly distributed load, it is substantially true for the loading supposed, when the excess of weight in the locomotives is not greater than occurs in practice.

"For a given intensity of load per unit of length, a uniform load over the whole span produces a greater moment of flexure at each cross section than any partial load."

"Call the extremities of the span 1 and 2, and any intermediate cross section 3. Then for a uniform load, the moment of flexure at 3 is an upward moment, being equal to the upward moment of the supporting force at either 1 or 2 relatively to 3, minus the downward moment of the uniform load between that end and 3. A partial load is produced by removing the uniform load from part of the span, situated either between 1 and 3, between 2 and 3, or at both sides of 3. First, let the load be removed from any part of the span between 1 and 3. Then the downward moment, relatively to 3, of the load between 2 and 3 is unaltered, and the upward moment, relatively to 3, of the supporting force at 2 is diminished in consequence of the diminution of the force; therefore the moment of flexure is diminished. A similar demonstration applies to the case in which the load is removed from a part of the span between 2 and 3; and the combined effect of those two operations takes place when the load is removed from portions of the span lying at both sides of 3; so that the removal of the load from any portion of the beam diminishes the moment of flexure at each point."

The stress upon a chord multiplied by the height of the truss is equal to the moment of flexure; hence in a truss of uniform height the stresses upon the chords are proportional to the moments of flexure, and when one has its greatest value the other has also.

The sides of the triangle c_1eb_1 represents the forces in equilibrium at the joint c_1eb_1 at the left abutment 1. The polygon $c_2c_1b_1a_2c_2$ represents the forces in equilibrium at the joint of the same name, *i.e.*, at the joint x_1 . The forces at the other joints are found in a similar manner.

It is unnecessary to complete the figure above e unless to check the process. The stresses obtained for the corresponding pieces in the right half of the truss would, upon completing the diagram, be found to be slightly less than those already determined because there are no locomotives at the right. The greatest stresses upon the pieces of the lower chord are eb_8 , eb_7 , etc., and on the upper chord are a_8c_8 , a_7c_7 , etc.

To determine the greatest stress upon the pieces of the bracing (posts and ties) it is necessary to find what distribution of loading causes the greatest shearing force at each joint, since the shearing forces are held in equilibrium by the bracing. We again quote nearly word for word from Rankine's Applied Mechanics.

"For a given intensity of load per unit of length, the greatest shearing force at any given cross-section in a span takes place when the longer of the two parts into which that section divides the span is loaded, and the shorter unloaded."

"Call the extremities of the span, as before, 1 and 2, and the given cross-section 3; and let 13 be the longer part, and 23 the shorter part of the span. In the first place, let 13 be loaded and 23 unloaded. Then the shearing force at 3 is equal to the supporting force at 2, and consists of a tendency of 23 to slide upwards relatively to 13. The load may be altered either by putting weight between 2 and 3, or by removing weight between 1 and 3. If any weight be put between 2 and 3, a force equal to *part* of that weight is added to the supporting force at 2, and, therefore, to the shearing force at 3; but at the same time a force equal to the *whole* of that weight is taken away from that shearing force; therefore the shearing force at 3 is diminished by this alteration of the load. If weight be removed from the load between 1 and 2, the shearing force at 3 is diminished also, because of the diminution of the supporting force at 2. Therefore any alteration from that distribution of load in which the longer segment 13 is loaded, and the shorter segment 23 is unloaded, diminishes the shearing force at 3."

The shearing force at any point is the resultant vertical force at that point, and can be computed by subtracting

from the weight which rests upon either abutment the sum of all the weights between that point and the abutment, *i.e.*, by taking the algebraic sum of all the external forces acting upon the truss from either extremity to the point in question; the reaction of the abutment is, of course, one of these external forces.

The greatest stress upon the brace a_1b_1 is that already found, while x_1 is loaded with the live load.

If the live load be moved to the right so that no live load rests upon x_1 , and the locomotives rest upon x_2 and x_3 , the pieces b_1a_2 and a_2b_2 will sustain their greatest stress. To find the shear at x_2 in that case, we notice that the change in position of the live load has changed the reaction c_1e of the left abutment by the following amounts: the reaction has been diminished by the quantity $y_1'''y_1'' = \frac{1}{16}(w' + w'')$, since the load at x_1 has been removed, and it has been increased by $y_3'y_3'' = \frac{1}{16}w''$, since x_3 is loaded more heavily than before, therefore the reaction of the abutment has on the whole been decreased by the total amount $\frac{1}{16}(15w' + 2w'')$.

Now the shear at x_2 is this reaction diminished by the load w at x_2 . In order to construct it, draw yy_{14}'' parallel to $y'o$, then $yy' = \frac{2}{16}w''$. \therefore Shear at $x_2 = ec_1 - w - \frac{1}{16}(15w' + 2w'') = ec_1 - x_1y_1$. Lay off $c_1c_2' = x_1y_1$, then the shear at $x_2 = ec_2'$ = the greatest stress in the brace b_1a_2 ; and b_2c_2' = the greatest stress in a_2b_2 .

Again, to find the greatest shear at x_3 when the live load has moved one panel further to the right, we have the equation: Shear at $x_3 = ec_2' - w - \frac{1}{16}(w' + w'') + \frac{1}{16}w'' = ec_2' - w - \frac{1}{16}(14w' + 2w'') = ec_2' - x_2y_2$. Lay off $c_2c_3' = x_2y_2$, then the shear at $x_3 = ec_3'$, which is the greatest stress in the piece b_2a_3 , while b_3c_3' is the greatest stress in a_3b_3 .

In similar manner lay off, $c_3c_4' = x_3y_3$, $c_4c_5' = x_4y_4$, etc., until the whole of the original reaction ec_1 of the abutment is exhausted, then are $ec_1, ec_2', ec_3', ec_4',$ etc., the successive shearing stresses at the end of the load, *i.e.* the greatest shearing stresses, and consequently these stresses are the greatest stresses on the successive vertical members of the bracing, while $c_1b_1, c_2'b_2', c_3'b_3',$ etc., are the great-

est stresses on the successive inclined members of the bracing.

Had the greater load, such as the locomotives, extended over a larger number of panels, the line $y_1y_2y_3$ would have cut off a larger fraction of $y'y''$. Suppose, for instance, that the locomotives had covered the joints x_1x_3 inclusive, then the line y_1y_2 would have passed through y_3'' , and been parallel to its present position. In that case the ordinates x_1y_1, x_2y_2 would have been successively subtracted from the reaction of the abutment due to a live load covering every joint, in order to obtain the shearing forces, just as at present, until we arrive at x_3 , after which it would be necessary to subtract the ordinates x_3y_3'', x_3y_3'' , etc. The counter braces are drawn with broken lines. Two counters are necessary on each side of the middle under the kind of loading which we have supposed. It is convenient, and avoids confusion in lettering the diagram to let a_3b_3 , for instance, denote the principal or counter indifferently, as both are not subject to stress at the same time.

The devices here used can be applied to a variety of cases in which the loading is not distributed in so simple a manner as in this case.

IN GENERAL.

This method permits the determination of the stresses in any frame when we know the relative position of its pieces and the applied forces, provided the disposition of the pieces is such as to admit of a determination of the stresses.

The determination of what the applied forces are in case of a continuous girder or arch is a matter of some complexity, depending upon the elasticity of the materials employed, and the method in its present form affords little assistance in finding them.

Some authors have applied the method to find the stresses induced in the various pieces of a frame by a single force first applied at one joint, and then at another, and so on, and, finally, to find the stresses induced by the action of several simultaneous forces, by taking the algebraic sum of their separate effects. This is theoretically correct but laborious in practice in ordinary cases. Usually, some supposition respecting the applied forces can be made from which the results of

all the other suppositions which must be made, can be derived with small labor. The bridge truss treated was a remarkable case in point.

WHEEL WITH TENSION-ROD SPOKES.

A very interesting example is found in the wheel represented in Fig. 4, in which the spokes are tension rods, and

the rim is under compression. Let the greatest weight which the wheel ever sustains be applied at the hub of the wheel on the left, and let this weight be represented by the force aa' on the right, which is also equal to the reaction of the point of support upon which the wheel stands; hence aa' represents the force acting between two joints of this

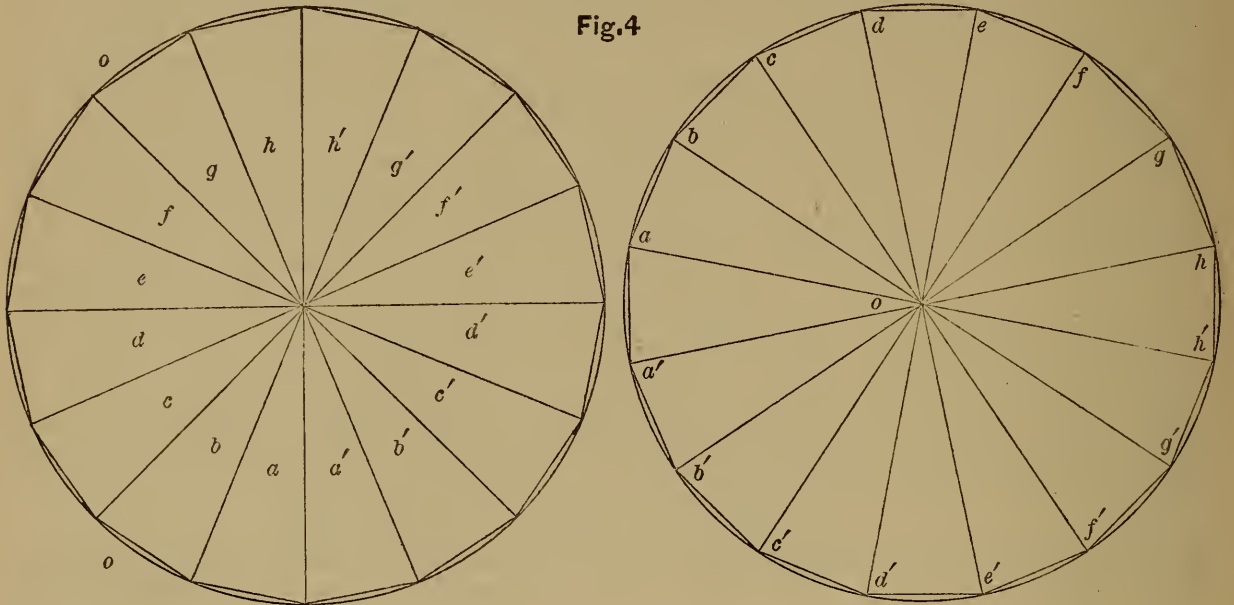

Fig.4

frame. The same effect would be caused upon the other members of the frame by "keying" the rod aa' sufficiently to cause this force to act between the hub and the lowest joint.

It should be noticed in passing, that the weights of the parts of the wheel itself are not here considered; their effect will be considered in Fig. 5. Also, the construction is based upon the supposition that there is a flexible joint at the extremity of each spoke. This is not an incorrect supposition when the flexibility of the rim is considerable compared with the extensibility of the spokes, a condition which is fulfilled in practice.

A similar statement holds in the case of the roof truss with continuous rafters, or a bridge truss with a continuous upper chord. The flexibility of the rafters or the upper chord is sufficiently great in comparison with the extensibility of the bracing, to render the stresses practically the same as if pin joints existed at the extremities of the braces.

Furthermore, the extremities of the spokes are supposed to be joined by straight pieces, since the forces be-

tween the joints of the rim act in those directions. Such forces will cause small bending moments in the arcs of the rim joining the extremities of the spokes. Each arc of the rim is an arch subjected to a force along its chord or span, and it can be treated by the method applicable to arches. This discussion is unimportant in the present case and will be omitted.

Upon completing the force polygon in the manner previously described, it is found that the stress on every spoke is the same in amount, and is represented by a side of the regular polygon $abcd$, etc. upon the left, while the compression of the pieces of the rim are represented by the radii oa , ob , etc.

As previously explained these diagrams are mutually reciprocal, and it happens in this case that they are also similar figures.

We then conclude that in designing such a wheel each spoke ought to be proportioned to sustain the total load, and that the maker should key the spokes until each spoke sustains a stress at least equal to that load. Then in no

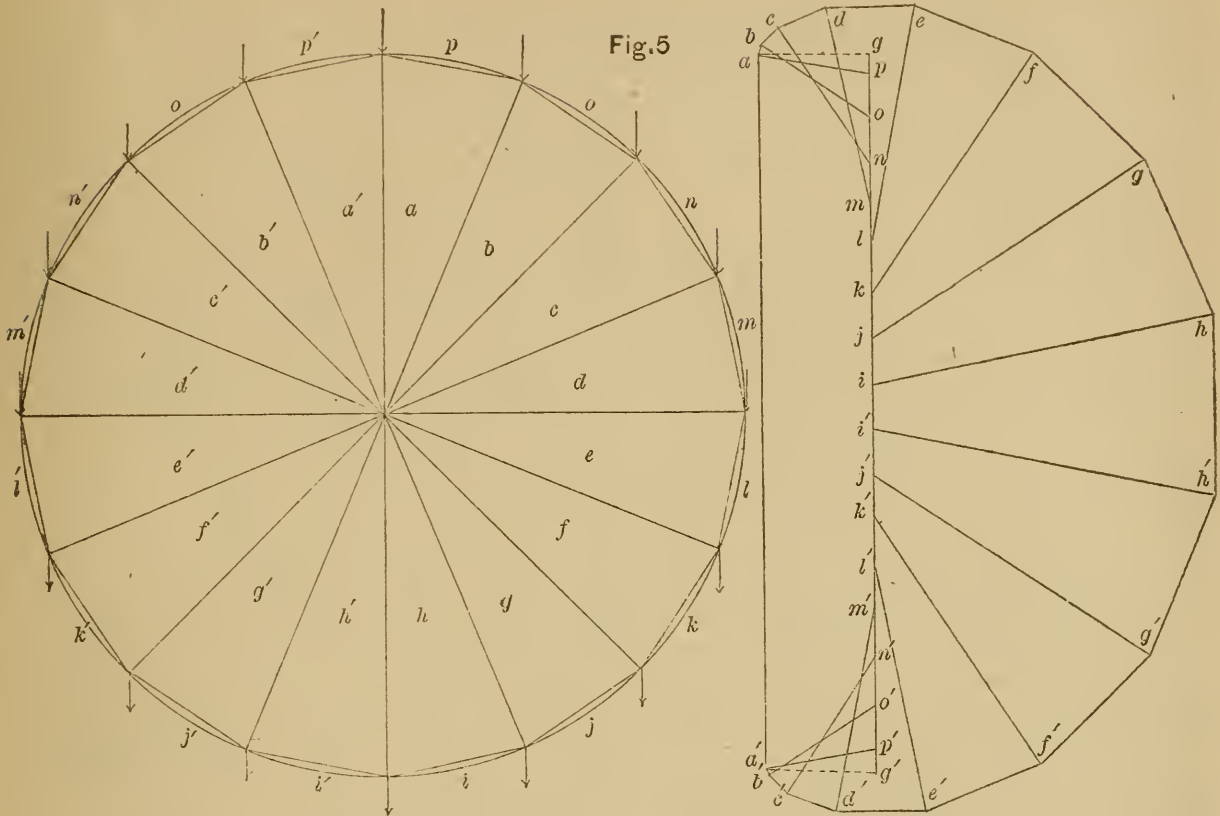

position of the wheel can any spoke become loose. The load here spoken of includes, of course, the effect of the most severe blow to which the wheel may be subjected while in motion.

WATER WHEEL WITH TENSION-ROD SPOKES.

The effect of a load distributed uniformly around the circumference of such a wheel as that just treated is represented in Fig. 5. Should it be desirable to compute the effect of both sets of forces upon the same wheel, it will be sufficient to take the sum of the separate effects upon each piece for the total effect upon that piece, though it is perfectly possible to construct both at once.

We shall suppose a uniform distribution of the loading along the circumference in the case of the Water Wheel, because in wheels of this kind such is practically the case so far as the spokes are concerned, since the power is transmitted, not through them to the axis, but, instead, to a cog wheel situated near the center of gravity of the "water arc." This arrangement so diminishes the necessary weight of the wheel, and the consequent friction of the gudgeons, as to render its adoption very desirable.

The discussion of the stresses appears however, to have been heretofore erroneously made.*

Let the weight pp' , at the highest joint of the wheel, be sustained by the rim alone, since the spoke aa' cannot assist in sustaining pp' , as aa' is suited to resist tension only. Conceive, for the moment, that two equal and opposite horizontal forces are introduced at the highest joint such as the two parts of the rim exert against each other, then $\frac{1}{2}pp' = pq = p'q'$ being sustained by each of the pieces ap , $a'p'$ respectively we have apq and $a'p'q'$ as the triangles which together represent the forces at the highest joint. The force aa' on the right is the upward force at the axis, equal and opposed to the resultant of the total load upon the wheel, and the apparent peculiarity of the diagram is due to this;—the direction of the reaction or sustaining force of the axis passes through the highest joint of the wheel and yet it is not a force acting between those joints and could not be replaced by keying the tie connecting those joints. In other particulars the force diagram is

* "A Manual of the Steam Engine, etc.," by W. J. M Rankine. Page 182, 7th Ed.

constructed as previously described and is sufficiently explained by the lettering. Should the spoke aa' have an initial tension greater than pp' , then there is a residual tension due to the difference of those quantities whose effect must be found as in Fig. 4.

Should the wheel revolve with so great a velocity that the centrifugal force must be considered, its effect will be to increase the tension on each of the spokes by the same amount,—the amount due to the deviating force of the mass supposed to be concentrated at the extremity of each spoke. The compression of the rim may be decreased by the centrifugal force, but as this is a temporary relief, occurring only during the motion, it does not diminish the maximum compression to which the rim will be subjected.

We conclude then, that every spoke must be proportioned to endure a tension as great as hh' from the loading alone; and that if other forces, due to centrifugal force or to keying, are to act they must be provided for in addition. Furthermore, we see that the rim must be proportioned to bear a compression as great as hi , due to the loading alone, and that the centrifugal force will not increase this, but any keying of the spokes beyond that sufficient to produce an initial tension on each spoke as great as pp' must be provided for in addition.

The diagram could have been constructed with the same facility in case the applied weights had been supposed unequal.

It can be readily shown that the differential equation of the curve circumscribing the polygon $abcd$, etc. of Fig. 5 is

$$y + x \frac{dx}{dy} + c \tan^{-1} \left(\frac{dx}{dy} \right) = 0$$

which equation is not readily integrable. When, however, the number of spokes is indefinitely increased, it appears from simple geometrical considerations that this curve becomes a cycloid having its cusps at q and q' .

ASSUMED FRAMING.

Thus far, we have treated the effect of known external forces upon a given form of framing, and it is evident from the previous discussions and the illustra-

tive examples that any such problem, which is of a determinate nature, can be readily solved by this method. But in case the problem under discussion has reference to the relations of forces among themselves, it is necessary to assume that the forces are applied to a frame or other body, in order to obtain the required relationship. Certain general forms of assumed framing have properties which are of material assistance in treating such problems, and this is true to such an extent that even though the form of framing to which the forces are applied is given, it is still advantageous to assume, for the time being, one of the forms having properties not found in ordinary framing. The special framing which has been heretofore assumed for such purposes is the Equilibrium Polygon, whose various properties will be treated in order. We now propose another form of framing, which we have ventured to call the Frame Pencil, with equally advantageous properties which will also be treated in due order.

It may be mentioned here, that the particular case of parallel forces is that most frequently met with in practice. In case of parallel forces the properties of the equilibrium polygon and frame pencil are more numerous and important than those belonging to the general case alone. We shall first treat the general case, and afterwards derive the additional properties belonging to parallel forces.

THE EQUILIBRIUM POLYGON FOR ANY FORCES IN ONE PLANE.

Let ab, bc, cd, de Fig. 6 be the diagram of any forces lying in the plane of the paper, and $abcde$ their force polygon, then, as previously shown, ae the closing side of the polygon of the applied forces represents the resultant of the given forces in amount and direction. Assume any point p as a pole, and draw the force pencil $p-abcde$. The object in view in so doing, is to use this force pencil and polygon of the applied forces together in order to determine a figure of which it is the reciprocal.

From any convenient point as 2 draw the side ap parallel to the ray ap until it intersects the line of action of the force ab , and from that intersection draw the side bp parallel to the ray bp , etc., etc.; then the polygon p will have its sides

EQUILIBRIUM POLYGON.

Fig.6

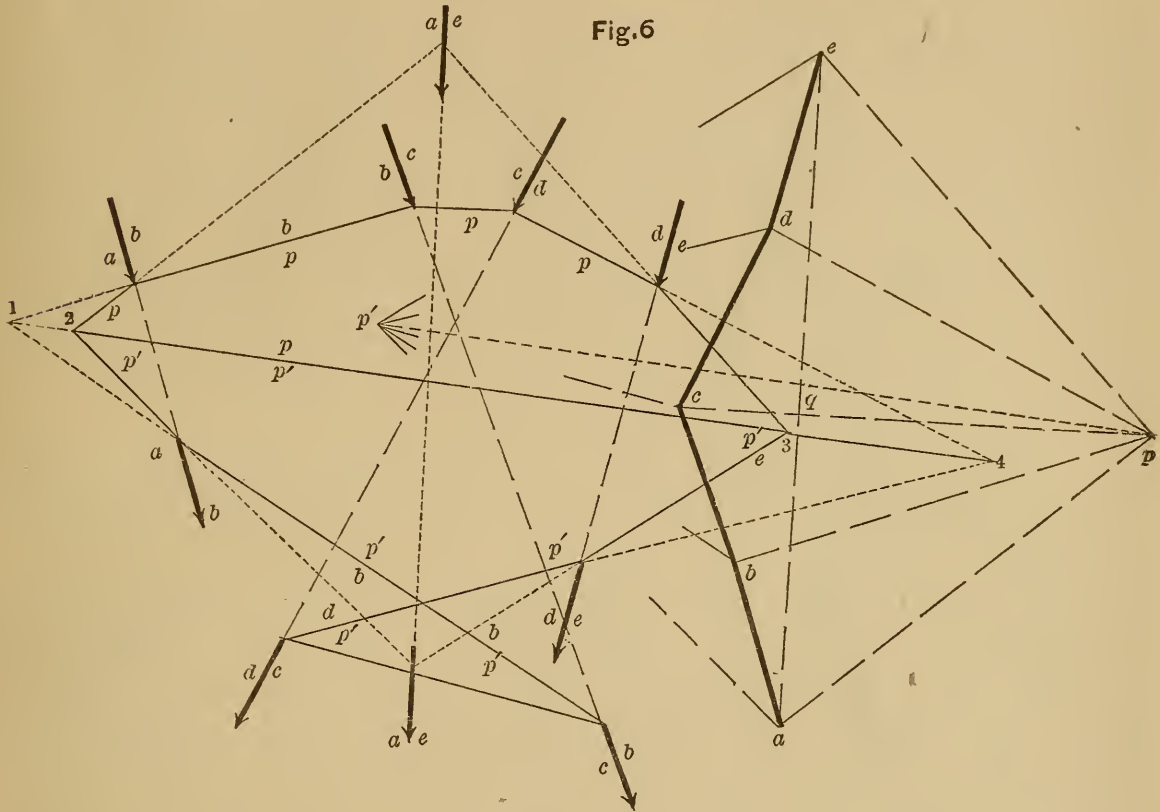

RECIPROCAL FIGURES.

<p>Direction and Position.</p>	}	Force Diagram,	<i>abcde,</i>	Force Polygon.	}	<p>Direction and Magnitude.</p>
		Equilibrium Polygon,	<i>ap, bp, cp, dp, ep,</i>	Force Pencil.		
		Equilibrium Polygon,	<i>ap', bp', cp', dp', ep',</i>	Force Pencil.		
		Closing Line,	<i>23 pq,</i>	Closing Ray.		
		Resultant Force,	<i>ae,</i>	Resultant Force.		

parallel respectively to the rays of the pencil p .

The polygon p and the given forces $ab, bc,$ etc, then form a force and frame diagram to which the pencil $p-abcde$ is reciprocal, and of which it is the force diagram. It is seen that no internal bracing is needed in the polygon p , and hence it is called an equilibrium (frame) polygon: it is the form which a funicular polygon, catenary, or equilibrated arch, would assume if occupying this position and acted upon by the given forces.

As represented in Fig. 6 the sides of the polygon p are all in compression so that p represents an ideal arch. If the line 23 be drawn cutting the sides ap, ep so that it be considered to be the span of the arch having the points of support 2 and 3, then this arch exerts a thrust in the direction 23 which may be borne either by a tie 23 or by fixed abutments 2 and 3: the force in either case is the

same and is represented by $pq \parallel 23$. It is usual to call 23 a closing line of the polygon p . The point q divides the resultant ae into two parts such that $qapq$ and $epqe$ are triangles whose sides represent forces in equilibrium, i.e., the forces at the points 2 and 3; hence, qa and eq are the parts of the total resultant which would be applied at 2 and 3 respectively.

This method is frequently employed to find the forces acting at the abutments of a bridge or roof truss such as that in Fig. 2. But it appears that it has often been erroneously employed. It must be first ascertained whether the reaction at the abutments is really in the direction ae for the forces considered. It may often happen far otherwise. If the surfaces upon which the truss rests without friction are perpendicular to ae , then this assumption is probably correct; as, for instance, when one end is mounted

on rollers devoid of friction, running on a plate perpendicular to ae . But in cases of wind pressure against a roof truss the assumption is believed to be in ordinary cases quite incorrect. Indeed, the friction of the rollers at end of a bridge has been thought to cause a material deviation from the determination founded on this assumption. It is to be noticed that any point whatever on pq (or pq prolonged) might be joined to a and e for the purpose of finding the reactions of the abutments. Call such a point x (not drawn), then ax and ex might be taken as two forces which are exerted at two and 3 by the given system. It appears necessary to call attention to this point, as the fallacious determination of the reactions is involved in a recently published article upon this subject.* We shall return to the subject again while treating parallel forces and shall extend the method given in connection with Fig. 2 to certain definite assumptions, such as will determine the maximum stresses which the forces can produce.

Prolong the two sides ap and ep of the polygon p until they meet. It is evident that if a force equal to the resultant ae be applied at this intersection of ap and ep prolonged, then the triangles apq and epq will represent the stresses produced at 2 and 3 by the resultant. But as these are the stresses actually produced by the forces, and as the resultant should cause the same effects at 2 and 3 as the forces, it follows that the intersection of ap and ep must be a point of the resultant ae ; and if, through this intersection, a line be drawn parallel to the resultant ae , it will be a diagram of the resultant, showing it in its true position and direction.

This is in reality a geometric relationship and can be proved from geometric considerations alone. It is sufficient for our purposes, however, to have established its truth from the above mentioned static considerations which may be regarded as mechanical proof of the geometric proposition.

The pole p was taken at random: let any other point p' be taken as a pole. To avoid multiplying lines p' has been

taken upon pq . Now draw the force pencil $p'-abcde$ and the corresponding equilibrium polygon for the same forces ab, bc , etc. This equilibrium polygon has all its pieces in tension except $p'e$. It is to be noticed that the forces are employed in the same order as in the previous construction, because that is the order in the polygon of the applied forces: but the order of the forces in the polygon of the applied forces is, at the commencement, a matter of indifference, for the construction did not depend upon any particular succession of the forces.

As previously shown, the intersection of ap' with ep' is a point of the resultant, and the line joining this intersection with the corresponding intersection above is parallel to ae .

Again, prolong the corresponding sides of the two equilibrium polygons until they intersect at 1234, these points fall upon one line parallel to pp' . For, suppose the forces which are applied to the lower polygon p' to be reversed in direction, then the system applied to the polygons p and p' must together be in equilibrium; and the only bracing needed is a piece $23 \parallel pp'$, since the upper forces produce a tension pq along it, and the lower forces a tension qp' , while the parts aq and qe of the resultant which are applied at 2 and 3 are in equilibrium. The same result can be shown to hold for each of the forces separately; e.g. the opposite forces ab may be considered as if applied at opposite joints of a quadrilateral whose remaining joints are 1 and 2: the force polygon corresponding to this quadrilateral is $apbp'$, hence $12 \parallel pp'$. Hence 1234 is a straight line. The intersection of pc and $p'e$ does not fall within the limits of the figure.

It is to be noticed that the proposition just proved respecting the collinearity of the intersections of the corresponding sides of these equilibrium polygons is one of a geometric nature and is susceptible of a purely geometric proof.

THE FRAME PENCIL FOR ANY FORCES IN ONE PLANE.

Let ab, bc, cd, de in Fig. 7 represent a system of forces, of which $abcde$ is the force polygon. Choose any single point upon the line of action of each of these

* See paper No. 71 of the Civil Engineers' Club of the Northwest. Applications of the Equilibrium Polygon to determine the Reactions at the Supports of Roof Trusses. By James R. Willett, Architect. Chicago.

FRAME PENCILS.

Fig.7

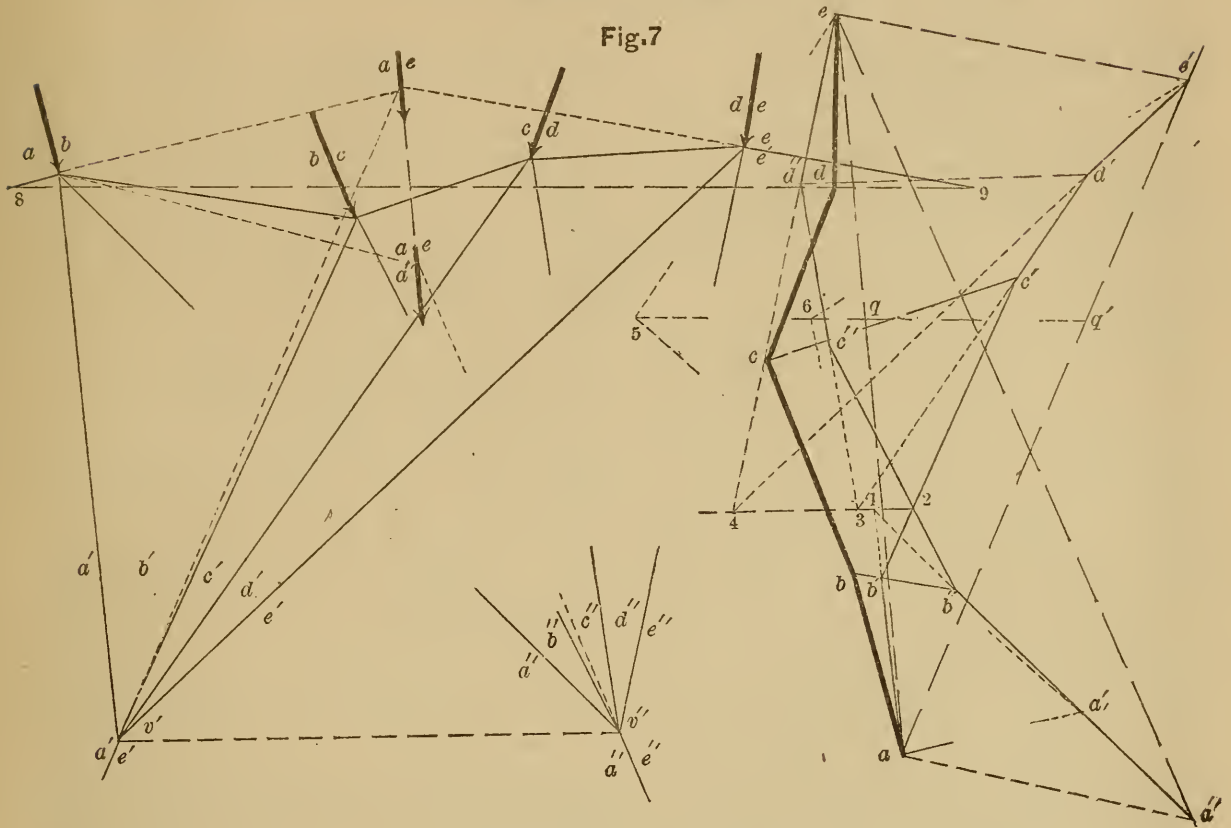

RECIPROCAL FIGURES.

Direction and Position.	}	Force Diagram, $a b c d e,$	Force Polygon.	Direction and Magnitude.
		Frame Pencil, $a' b' c' d' e',$	Equilibrating Polygon.	
		Frame Pencil, $a'' b'' c'' d'' e'',$	Equilibrating Polygon.	
		Frame Polygon, $b b', c c', d d', e e',$	Force Lines.	
		Resultant Force, $a e,$	Resultant Force.	
		Resultant Ray, $a' e',$	Resultant Side.	

forces, and join these points to any assumed vertex v' by the rays of the frame pencil $a'b'c'd'e'$. Also join the successive points chosen by the lines bb', cc', dd' which form sides of what we shall call the frame polygon. Now consider the given forces to be borne by the frame pencil and frame polygon as a system of bracing, which system exerts a force at the vertex v' in some direction not yet known, and also exerts a force along some assumed piece ee' , which may be regarded as forming a part of the frame polygon. The stresses upon the rays of the frame pencil will be represented by the sides of $ab'c'd'e'$ which we shall call the equilibrating (force) polygon; while the stresses in the frame polygon are given by the force lines $bb', cc',$ etc. If a resultant ray $a'e'$ be drawn from v' parallel to the resultant side ae' of the equilibrating polygon it will intersect ee' at a point of the resultant of the system

of forces; for that is a point at which if the resultant be applied it will cause the same stresses along the pieces $a'e'$ and ee' which support it as do the forces themselves.

If the point e' in the force polygon be moved along $e'd'$, the locus of the intersection of the corresponding positions of the resultant ray $a'e'$ and the last side ee' will be the resultant ae . It would have been unnecessary to commence the equilibrating polygon at a had the direction of aa' been known. Having obtained the direction of aa' as shown at 8, the equilibrating polygon could be drawn by commencing at any point of $aa', \parallel aa'$.

In cases like that in the Fig., where there is no reason for choosing the points which determine the sides of the frame polygon otherwise, it is simpler to make the frame polygon a straight line, which may in that case be called the frame

line. Then the force lines are parallel to each other and to aa' also. This is a practical simplification of the general case of much convenience.

It should be noticed here that the equilibrium polygon, as well as the straight line, is one case of the frame polygon. The interesting geometric relationships to be found by constructing the frame and equilibrium polygons as coincident must be here omitted.

Suppose that it is desired to find the point q which divides the resultant into two parts, which would be applied in the direction of the resultant at two such points as 8 and 9: draw $a6 \parallel v'8$ and $e'6 \parallel v'9$ and then through 6 draw $qq' \parallel 89$. This may be regarded as the same geometric proposition, which was proved when it was shown that the locus of the intersection of the two outside lines of the equilibrium polygons (reciprocal to a given force pencil) is the resultant, and is parallel to the closing side of the polygon of the applied forces. The proposition now is, that the locus of the intersection of the two outside lines of the equilibrating polygon (reciprocal to a given frame pencil) is the resolving line, and is parallel to the abutment line: for these two statements are geometrically equivalent.

Assume a different vertex v'' , and draw the frame pencil and its corresponding equilibrating polygon $a''b''c''d''e$. If $a_1 5$ and $e 5$ be drawn parallel to $v'' 8$ and $v'' 9$ respectively their intersection is upon qq' as before proven.

Again, the corresponding sides of these two equilibrating polygons intersect at 1 2 3 4 upon a line parallel to $v'v''$, for this is the same geometric proposition respecting two vertices and their equilibrating polygons which was previously proved respecting two poles and their equilibrium polygons.

It would be interesting to trace the geometric relations involved in different but related frame polygons, as for example, those whose corresponding sides intersect upon the same straight line, but as our present object is to set forth the essentials of the method, a consideration of these matters is omitted. Enough has been proven, however, to show that we have in the frame pencil an independent method equally general and

fruitful with that of the equilibrium polygon.

EQUILIBRIUM POLYGON FOR PARALLEL FORCES.

LET the system of parallel forces in one plane be four in number as represented in Fig. 8, viz: $w_1 w_2, w_3 w_4$, etc., acting in the verticals 2 3 4 5 of the force diagram on the left. Let the points of support be in the verticals 1 and 6.

The force polygon at the right reduces, in case of vertical forces, to a vertical line $w_1 w_2$. Assume any arbitrary point p as pole of this force polygon, (or weight line, as it is often designated) and, parallel to the rays of the force pencil at p , draw the sides of the equilibrium polygon ee , in the manner previously described. Draw the closing line kk of this polygon ee , and parallel to it draw the closing ray pq ; then, as previously shown, pq divides the resultant $w_5 w_6$, at q into two parts which are the reactions of the supports. The position of the resultant is in the vertical mm which passes through the intersection of the first and last sides of the polygon ee , as was also previously shown.

Designate the horizontal distance from p to the weight line by the letter H . It happens in Fig. 8 that $pw_1 = H$, but in any case the pole distance H is the horizontal component of the force pq acting along the closing line.

Now by similarity of triangles

$$k_1 e_2 (=h_1 h_2) : k_2 e_2 :: pw_1 : qw_1 \\ \therefore H \cdot k_2 e_2 = qw_1 \cdot h_1 h_2 = M_2,$$

the moment of flexure, or bending moment at the vertical 2, which would be caused in a simple straight beam or girder under the action of the four given forces and resting upon supports in the verticals 1 and 6.

Again, from similarity of triangles,

$$h_1 h_3 (=k_1 f_3) : k_3 f_3 :: H : qw_1 \\ h_2 h_3 (=e_2 f_3) : e_3 f_3 :: H : w_1 w_2 \\ \therefore H (k_3 f_3 - e_3 f_3) = H \cdot k_3 e_3 \\ = qw_1 \cdot h_1 h_3 - w_1 w_2 \cdot h_2 h_3 = M_3,$$

the moment of flexure of the simple girder at the vertical 3.

Similarly it can be shown in general that

$$H \cdot ke = M,$$

EQUILIBRIUM POLYGON.

Fig. 8

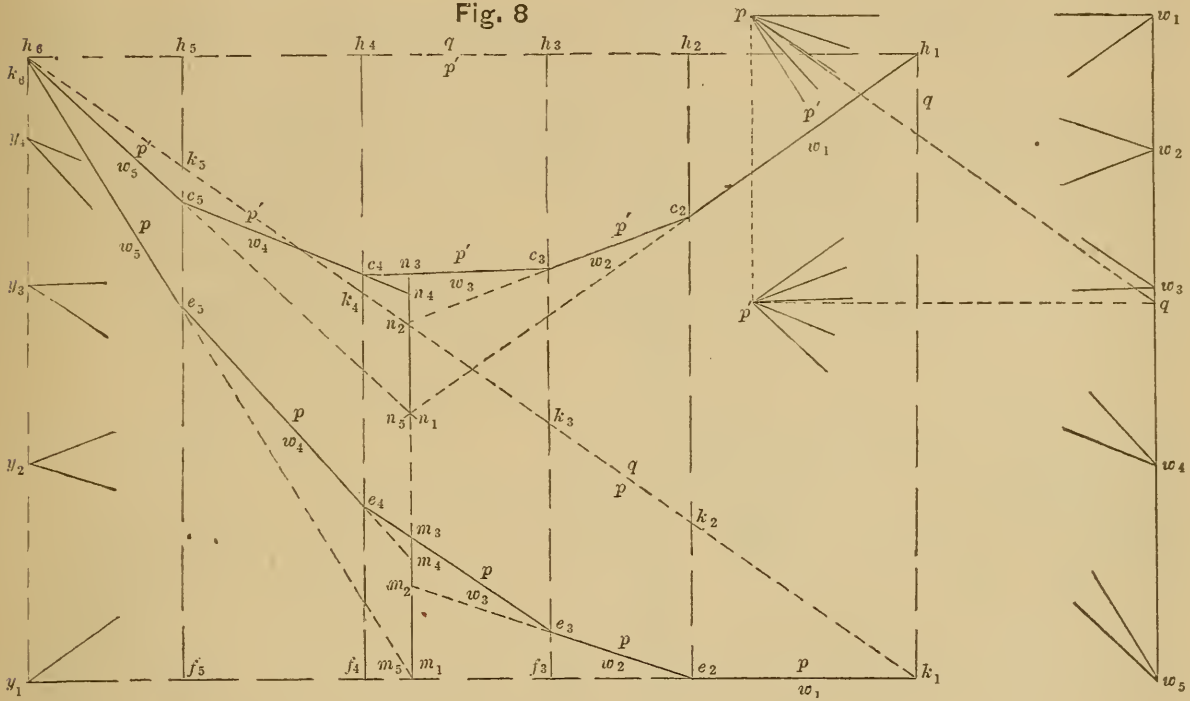

i.e. that the moment of flexure at any vertical whatever (be it one of the verticals 2 3 4, etc., or not) is equal to the product of the assumed pole distance H multiplied by the vertical ordinate ke included between the equilibrium polygon ee and the closing line kk at that vertical.

From this it is evident that the equilibrium polygon is a moment curve, *i.e.* its vertical ordinate at any point of the span is proportional to the bending moment at that point of a girder sustaining the given weights and supported by simply resting without constraint upon piers at its extremities.

From this demonstration it appears that $H.e_3.f_3 = w_1.w_2.h_2.h_3$ is the moment of the force $w_1.w_2$ with respect to the vertical 3; and similarly $H.m_1.m_2 = w_1.w_2.e_2.m_1$ is the moment of the same force with respect to the vertical through the center of gravity. Also, $H.y_1.y_2 = w_1.w_2.h_2.h_6$ is the moment of the same force with respect to the vertical 6.

Similarly $m_1.m_3$ is proportional to the moment of all forces at the right, and $m_3.m_5$ to all the forces left of the center of gravity, but $m_1.m_3 + m_3.m_5 = 0$, as should be the case at the center of gravity, about which the moment vanishes. From these considerations it appears that the segments mm of the resultant

are proportional to the bending moments of a girder supporting the given weights and resting without constraint upon a single support at their center of gravity.

Let us move the pole to a new position p' having the same pole distance H as p , and in such a position that the new closing line will be horizontal, *i.e.* $p'q$ must be horizontal.

One object in doing this is to furnish a sufficient test of the correctness of the drawing in a manner which will be immediately explained; and another is to transfer the moment curve to a new position cc such that its ordinates may be measured from an assumed horizontal position hh of the girder to which the forces are applied, so that the girder itself forms the closing line.

The polygon cc must have its ordinates hc equal to the corresponding ordinates ke , for

$$M = H.ke = H.hc$$

Also the segments of the line mm are equal to the corresponding segments of the line nn for similar reasons.

Again, as has been previously shown, the corresponding sides (and diagonals as well) of the polygons ee and cc intersect upon the line $yy \parallel pp'$.

These equalities and intersections furnish a complete test of the correctness of the entire construction.

vertical distance V multiplied by the corresponding segment rr of the resolving line.

The moment of flexure at *any* point of the girder may be found by drawing a line tangent to the equilibrating polygon (or curve) parallel to a ray of the frame pencil at that point, the intercept r_1r of this tangent is such that $V.r_1r$ is the moment required.

Also by similarity of triangles

$$o2 : v6 :: u_2d_2 : w_1w_2$$

$$\therefore V.u_2d_2 = w_1w_2.o2$$

$$o2(=o3+32) : v6 :: u_3l : w_1w_3$$

$$32 : v6 :: d_3l : w_2w_3$$

$$\therefore V(u_3l - d_3l) = V.u_3d_3 = w_1w_2.o2 + w_2w_3.o3,$$

i.e. the horizontal abscissas ud between the equilibrating polygon dd and its closing side uu multiplied by the vertical distance V are the algebraic sum of the moments of the forces about their center of gravity. The moment of any single force about the center of gravity being the difference between two successive algebraic sums may be found thus: draw $d_2i \parallel uu$, then is $V.d_2i$ the moment of w_1w_2 about the center of gravity, as may be also proved by similarity of triangles.

Again by proportions derived from similar triangles, precisely like those already employed, it appears that

$$V.w_2d_2 = w_1w_2.26$$

is the moment of the force w_1w_2 about the point 6. And similarly it may be shown that

$$V.w_3d_3 = w_1w_2.26 + w_2w_3.36$$

is the moment of w_1w_2 and w_2w_3 about 6.

Furthermore, as this point 6 was not specially related to the points of application 1 2 3 4, we have thus proved the following property of the equilibrating polygon: if a pseudo resultant ray of the frame pencil be drawn to any point of the frame line, then the horizontal abscissas between the equilibrating polygon and a side of it parallel to that ray, (which may be called a pseudo closing side), are proportional to the sum total of the moments about that point of those forces which are found between that abscissa and the end of the weight line from which this pseudo side was drawn. The difference between two successive

sum totals being the moment of a single force, a parallel to the pseudo side enables us to obtain at once the moment of any force about the point, *e.g.* draw $d_4i' \parallel ww \therefore V.d_4i'$ is the moment of w_4w_5 about 6.

Now move the vertex to a new position v' in the same vertical with o : this will cause the closing side of the equilibrating polygon (parallel to $v'o$) to coincide with the weight line. The new equilibrating polygon bb has its sides parallel to the rays of the frame pencil whose vertex is at v' . If V is unchanged the abscissas and segments of the resolving line are unchanged, and vv' is horizontal. Also $xx \parallel vv'$ contains the intersections of corresponding sides and diagonals of the equilibrating polygon. These statements are geometrically equivalent to those made and proved in connection with the equilibrium polygon and force pencil.

In Figs. 8 and 9 we have taken $H=V$, hence the following equations will be found to hold,

$$\begin{aligned} k_2e_2 &= r_1r_2, k_3e_3 = r_1r_3, k_4e_4 = r_1r_4, \text{ etc.} \\ m_1m_2 &= u_2d_2, m_1m_3 = u_3d_3, m_1m_4 = u_4d_4, \text{ etc.} \\ y_1y_2 &= w_2d_2, y_1y_3 = w_3d_3, y_1y_4 = w_4d_4, \text{ etc.} \\ m_2m_3 &= d_3i, \text{ etc.}, y_4k_6 = d_5i', \text{ etc.} \end{aligned}$$

By the use of *etc.* we refer to the more general case of many forces. From these equations the nature of the relationship existing between the force and frame pencils and their equilibrium and equilibrating polygons becomes clear. Let us state it in words.

The height of the vertex (a vertical distance), and the pole distance (a horizontal force) stand as the type of the reciprocity or correspondence to be found between the various parts of the figures. *

The ordinates of the equilibrium polygon (vertical distances) correspond to the segments of the resolving line (horizontal forces), each of these being proportional to the bending moments of a simple girder sustaining the given weights, and resting without constraint upon supports at its two extremities.

The segments of the resultant line (vertical distances) correspond to the abscissas of the equilibrating polygon (horizontal forces) each of these being proportional to the bending moments of

a simple girder sustaining the given weights and resting without constraint upon a support at their center of gravity.

The segments of any pseudo resultant line, parallel to the resultant, which are cut off by the sides of the equilibrium polygon, are proportional to the bending moments of a girder supporting the given weights and rigidly built in and supported at the point where the line intersects the girder; to these segments correspond the abscissas between the equilibrating polygon and a pseudo side of it parallel to the pseudo resultant ray.

The two different kinds of support which we have supposed, viz. support without constraint and support with constraint, can be treated in a somewhat more general manner, as appears when we consider that at any point of support there may be, besides the reaction of the support, a bending moment, such as would be induced, for instance, when the span in question forms part of a continuous girder, or when it is fixed at the support in a particular direction. In such a case the closing line of the equilibrium polygon is said to be moved to a new position. It seems better to call it in its new position a pseudo closing line. The ordinates between the pseudo closing line and the equilibrium polygon are proportional to the bending moments of

the girder, so supported. It is possible to induce such a moment at one point of support as to entirely remove the weight from the other, and cause it to exert no reaction whatever; and any intermediate case may occur in which the total weight in the span is divided between the supports in any manner whatever. When the weight is entirely supported at h_6 , then y_1e_2 is the pseudo closing line of the polygon ee . In that case xx becomes the pseudo resolving line, and in general the ordinates between the pseudo closing line and the equilibrium polygon correspond to the segments of the pseudo resolving line, and are proportional to the bending moments of the girder. This general case is not represented in Figs. 8 and 9; but the particular case shown, in which the total weight is borne by the left pier, gives the equations

$$e_3f_3 = w_1x_2, e_4f_4 = w_1x_3, e_5f_5 = w_1x_4, \text{ etc.}$$

In order to represent the general case in which the weights, supported by the piers, are not the same as in the case of the simple girder, by reason of some kind of constraint, we propose to treat the case of the straight girder, fixed horizontally at its extremities; but it is necessary first to discuss the following auxiliary construction.

SUMMATION POLYGON.

Fig. 10

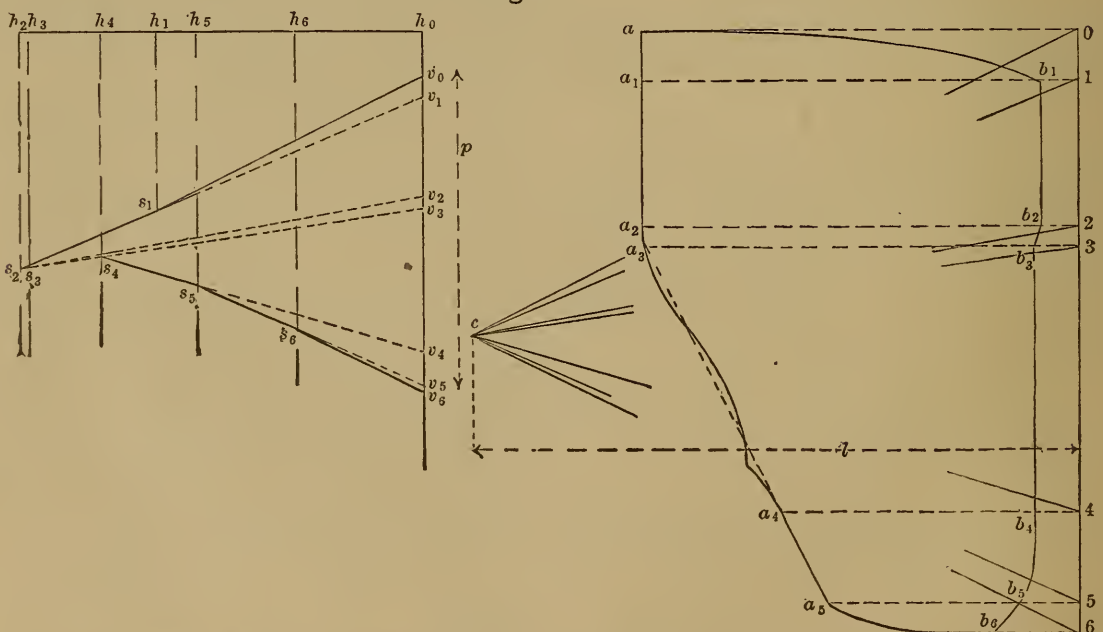

THE SUMMATION POLYGON.
In Fig. 10 let $aabb$ be any closed

figure of which we wish to determine the area. The example which we have

chosen is that of an indicator card taken from page 12 of Porter's Treatise on Richard's Steam Indicator, it being a card taken from the cylinder of an old-fashioned paddle-wheel Cunarder, the Africa. The scale is such that a_1b_1 is 26.9 pounds per square inch and 06 parallel to the atmospheric line is the length of the stroke.

Divide the figure by parallel lines a_1b_1 , a_2b_2 , etc. into a series of bands which are approximately trapezoidal. A sufficient number of divisions will cause this approximation to be as close as may be desired. The upper and lower bands may in the present case be taken as approximating sufficiently to parabolic areas. Let 06 be perpendicular to a_1b_1 , etc., then will 01, 12, etc., be the heights of the partial areas. Lay off

$$h_0h_1 = \frac{2}{3} a_1b_1, \quad h_0h_2 = \frac{1}{2}(a_1b_1 + a_2b_2), \\ h_0h_3 = \frac{1}{2}(a_2b_2 + a_3b_3), \text{ etc.}$$

then will these distances be the bases of the partial areas. Assume any point c at a distance l from 06 as the common point of the rays of a pencil passing through 0, 1, 2, etc.; and draw the parallels hs : then from any point v_0 of the first of these make $v_0s_1 \parallel c0$, and $s_1s_2 \parallel c1$, $s_2s_3 \parallel c2$, etc.

The polygon ss is called the summation polygon, and has the following properties.

By similarity of triangles

$$l : 01 :: h_0h_1 : v_0v_1, \quad \therefore 01.h_0h_1 = l.v_0v_1$$

is the area of the upper band. Similarly $12.h_0h_2 = l.v_0v_2$ is the area of the next band, and finally

$$06\Sigma(h_0h) = l.v_0v_6 = lp$$

is the total area of the figure.

In the present instance we have taken $l=06$, the length of stroke, consequently p is the average pressure during the stroke of the piston, and is 21.25 pounds, which multiplied by the volume of the cylinder gives the work per stroke.

This method of summation, which obtains directly the height p of a rectangle of given base l equivalent in area to any given figure, is due to Culmann, and is applicable to all problems in planimetry; it is especially convenient in treating the problems met with in equalizing the areas of profiles of excavation and embankment, and is frequently of use in

dividing land. It is much more expeditious in application than the method of triangles founded on Euclid, and is also, in general, superior to the method of equidistant ordinates, whether the partial areas are then computed as trapezoids or by Simpson's Rule; for it reduces the number of ordinates and permits them to be placed at such points as to make the bands approximate much more closely to true trapezoids than does the method of equidistant ordinates.

GIRDER WITH FIXED ENDS.

It is to be understood that by a girder with fixed ends, we mean one from which if the loading were entirely removed, without removing the constraint at its ends, there would be no bending moment at any point of it, and, when the loading is applied to it the supports constrain the extremities to maintain their original direction unchanged, but furnish no horizontal resistance. Under those circumstances the girder may not be straight, and may not have its supports on the same level, but it will be more convenient to think of the girder as straight and level, as the moments, etc., are the same in both cases.

Suppose in Fig. 11 that any weights w_1w_2 , etc. are applied at h_2, h_3, h_4, h_5 , to a girder which is supported and fixed horizontally at h_1 and h_6 . With p as the pole of a force pencil draw the equilibrium polygon ee as in Fig. 8. The resultant passes through m .

It is shown in my New Constructions in Graphical Statics, Chapter II, that the position of the pseudo closing line $k'k'$, in case the girder has its ends fixed as above stated, is determined from the conditions that it shall cut the curve ee in such a way that the moment area above $k'k'$ shall be equal to that below $k'k'$, and also in such a way that the center of gravity of the new moment area shall be in the same vertical as the original moment area.

To find the center of gravity of the moment area ek ; determine the areas of the various trapezoids of which it is composed by help of the summation polygon ss . In constructing ss we make $h_21 = k_2e_2$, $h_22 = k_2e_2 + k_3e_3$, etc., and using v as the common point of the pencil we

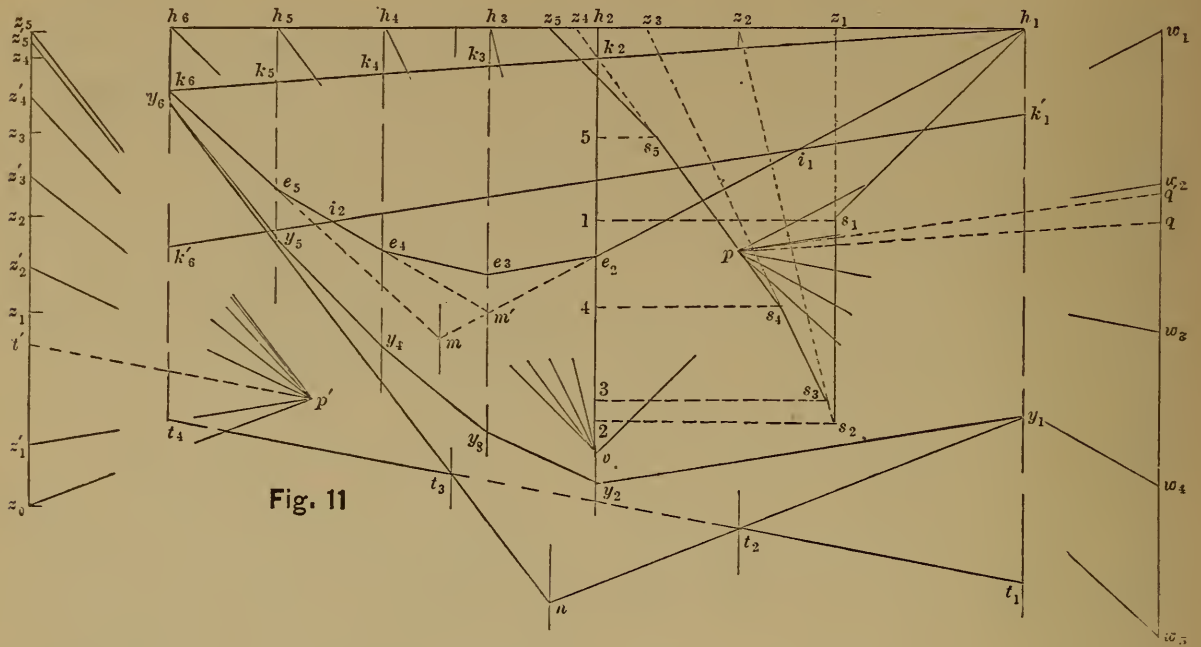

Fig. 11

shall have $h_2 v . h_1 z_5 =$ twice the area of the moment area. We have used the sum of the two parallel sides of each trapezoid instead of half that quantity for greater accuracy.

Now lay off from z_0 , $z_0 z_1 = h_1 z_1$, $z_0 z_2 = h_1 z_2$, etc., as a weight line and assume the pole p' .

Of the triangle $h_1 h_2 e_2$, one-third rests at h_1 and two-thirds at h_2 ; make $z_0 z_1' = \frac{1}{3} z_0 z_1$, it is the part of the area applied at h_1 . Of the area $h_2 e_2 e_3 h_3$, one half, approximately, rests at h_2 and one half at h_3 . Bisect $z_1 z_2$ at z_2' , then $z_1' z_2'$ rests at h_2 . Bisect each of the other quantities $z_2 z_3$, etc. except $z_4 z_5$, in which make $z_5 z_5' = \frac{1}{3} z_5 z_4$. With the weights $z' z'$ so obtained, construct the second equilibrium polygon yy , which shows that the center of gravity of the moment area is in the vertical through n . There is a balancing of errors in this approximation which renders the position of n quite exact; if, however, greater precision is desired, determine the centers of gravity of the trapezoids forming the moment area, and use new verticals through them as weight lines, with the weights zz instead of the weights $z' z'$.

Draw verticals which divide the span into three equal parts,—they cut ny_1 and ny_6 at t_2 and t_3 , and draw $p' t' \parallel t_2 t_3$. Then is $t_1 t_2 n t_3 t_4$ an equilibrium polygon due to the force $z_5 z_0$ applied at n , and to the forces $z_0 t'$, and $t' z_5$ applied at t_2 and t_3 respectively. As explained when

treating this matter in the New Constructions in Graphical Statics, $z_0 t'$ and $t' z_5$ are proportional to the bending moments at the extremities of the fixed girder. In this case, since we have taken $h_2 v = \frac{1}{2} h_1 h_6$, we find that $h_1 k_1' = \frac{1}{2} z_0 t'$, and $k_6 k_6' = \frac{1}{2} t' z_5$ are the end moments, and they fix the position of the pseudo closing line. Draw $p q' \parallel k' k'$ then are $w_1 q'$ and $q' w_6$ the reactions of the piers. The pseudo resultant is at m' .

To obtain the same result by help of a frame pencil, let Fig. 12 represent the same weights applied in the same manner as in Fig. 11. Choose the vertex v , and draw the equilibrating polygon dd , etc. as in Fig. 8. Make $h_2 1 = r_1 r_2$, $h_2 2 = r_1 r_2 + r_1 r_3$, etc., since these quantities are proportional to the bending moments as previously shown. With v as the common point of the rays of a pencil, find $h_1 z_5$ by the help of the summation polygon ss just as in Fig. 11.

Lay off the second weight line $z_0 z_1'$, etc., just as in Fig. 11, and with v as vertex construct the second equilibrating polygon xx . Then as readily appears $vn \parallel z_0 x_6$ determines n the center of gravity of the moment area. Make $z_0 x_0 \parallel vt_2$ and $x_6 x_0 \parallel vt_3$; if t_2 and t_3 divide the span into three equal parts, then the horizontal through x_0 fixes t' corresponding to t' in Fig. 11.

To find the position of the pseudo resolving line and its segments proportional to the new bending mo-

ments, lay off $r_1 j = \frac{1}{2}(t' z_5 - z_0 t')$ the difference of the bending moments at the ends, and make $j r_6' \parallel r_1 w_1$ and prolong $u_5 r_6'$ until they meet at r_6' which is on the pseudo resolving line. Then lay off $r_1 r' = \frac{1}{2} z_0 t'$ and $r_6' r' = \frac{1}{2} t' z_5'$ upon this pseudo resolving line $r' q'$, then $r' r_2', r' r_3',$ etc., are the bending moments when the girder is fixed at the ends. For by similarity of triangles

$$h_1 h_6 : V :: r_1' r_6' : q q',$$

$$\therefore h_1 h_6 \cdot q q' = V \cdot r_1' r_6',$$

is the moment, and $q q'$ is the weight which is transferred from one support to the other by the constraint, hence $r' q'$ is the correct position of the pseudo resolv-

ing line. Thence follows the proof that the bending moments are proportional to intercepts upon this line in a manner precisely like that employed in Fig. 9.

Again, draw $v i_1 \parallel w_1 r'$ and $v i_2 \parallel u_5 r_6'$, then are i_1 and i_2 the points of inflexion of the girder when the bending moment vanishes, being in reality points of support on which the girder could simply rest without constraint and have the pseudo resultant in that case as the true resultant.

In Figs. 11 and 12 we have taken $H = V$, consequently the new moments can be directly compared, the ordinates $k'e$ being equal to the corresponding segments $r'r$.

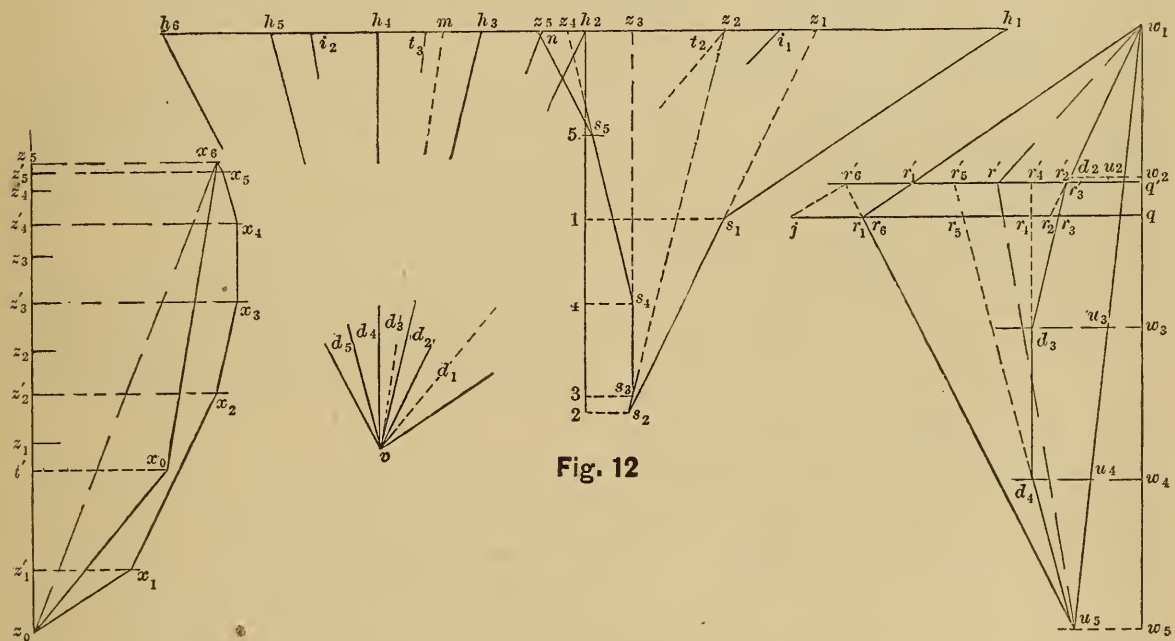

Fig. 12

Apparently in this example Fig. 12 presents a construction somewhat more compact than that of Fig. 11, it is certainly equally good.

It remains to remark before proceeding to further considerations of a slightly different character, that we owe to the genius of Culmann* the establishment of the generality of the method of the equilibrium polygon.

He adopted the funicular polygon, some of whose properties had long been known, and upon it founded the general processes and methods of systematic work which are now employed by all.

Furthermore it should be stated that parallelograms of forces were compounded and applied in such a way as to

give rise to a frame pencil and equilibrating polygon by the illustrious Poncelet* who by their use determined the centers of gravity of portions of the stone arch. Whether he recognized other properties besides the simple determination of the resultant of parallel forces, I am not informed, as my knowledge of Poncelet's memorial is derived from so much of his work as Woodbury† has incorporated in his graphical construction for the stone arch.

So far as known, the method has been advanced by no one of the numerous recent writers upon Graphical Statics

* Graphische Statik. Zurich, 1866.

* Memorial de l'officier du Genie. No. 12.
† Treatise on the Stability of the Arch. D. P. Woodbury, New York, 1858.

which would certainly have been the case had Poncelet established its claim to be regarded as a general method. I think the method of the frame pencil may now fairly claim an equal generality and importance with that of the equilibrium polygon.

ANY FORCES LYING IN ONE PLANE, AND APPLIED AT GIVEN POINTS.

We have previously referred to this problem, having treated a particular case of it in Fig. 2; and subsequently certain statements were made respecting the indeterminateness of the process for finding the reactions of supports in case the applied forces were not vertical.

The case most frequently encountered in practice is wind-pressure combined with weight, and we can take this case as being sufficiently general in its nature; so that we are supposed to know the precise points of application of each of the forces, and its direction. Now it may be that the reaction of the supports cannot be exactly determined, but in all cases an extreme supposition can be made which will determine stresses in the framework which are on the safe side.

For example, if it is known that one of the reactions must be vertical, or normal to the bed plate of a set of supporting rollers, this will fix the direction of one reaction and the other may then be found by a process, like that employed in Fig. 2, of which the steps are as follows:

Resolve each of the forces at its point of application into components parallel and perpendicular to the known direction of the reaction, which we will call vertical for convenience, since the process is the same whatever the direction may be. By means of an equilibrium polygon or frame pencil find the line of action of the resultant of the horizontal components, whose sum is known. Then this horizontal resultant, can be treated precisely as was the single horizontal force in Fig. 2, which will determine the alteration of the vertical components of the reactions due to the couple caused by the horizontal components.

Also, find by an equilibrium polygon, or frame pencil, the vertical reactions due to the vertical components. Correct the point of division q of the weight line as found from the vertical components by

the amount of alteration already found to be due to the horizontal components. Call this point q' , then the polygon of the applied forces must be closed by two lines representing the reactions, which must meet on a horizontal through q' ; but one of them has a known direction, hence the other is completely determined.

This determination causes the entire horizontal component to be included in a single one of the reactions, and it is usually one of the suppositions to be made when it is not known that the reaction of a support is normal to the plane of the bed joint.

Another supposition in these circumstances is that the horizontal component is entirely included in the other reaction; and a third supposition is that the horizontal component is so divided between the reactions that they have the same direction. These suppositions will usually enable us to find the greatest possible stress on any given piece of the frame by taking that stress for each piece which is the greatest of the three.

In every supposition care must be taken to find the alteration of the vertical components due to the horizontal components. This is the point which has been usually overlooked heretofore.

KERNEL, MOMENTS OF RESISTANCE AND INERTIA: EQUILIBRIUM POLYGON METHOD.

The accepted theory respecting the flexure of elastic girders assumes that the stress induced in any cross section by a bending moment increases uniformly from the neutral axis to the extreme fiber.

The cross section considered, is supposed to be at right angles to the plane of action or solicitation of the bending moment, and the line of intersection of this plane with that of the cross section is called the axis of solicitation of the cross section.

The radius of gyration of the cross section about any neutral axis is in the direction of the axis of solicitation.

It is well known that these two axes intersect at the center of gravity of the cross section, and have directions which are conjugate to each other in the ellipse which is the locus of the extremities of the radii of gyration.

We shall assume the known relation

$$M = SI \div y$$

in which M is the magnitude of the bending moment, or moment of resistance of the cross section, S is the stress on the extreme fiber, I is the moment of inertia about any neutral axis x , and y is the distance of the extreme fiber in the direction of the axis of solicitation, *i. e.* the distance between the neutral axis x and that tangent to the cross section which is parallel to x and most remote from it, the distance being measured along the axis of solicitation.

Let $M = Sm$ in which m is called the "specific moment of resistance" of the cross section; it is, in fact, the bending moment which will induce a stress of unity on the extreme fiber.

$$\text{Now} \quad I = k^2 A$$

in which k is the radius of gyration and A is the area of the cross section.

$$\text{Let} \quad k^2 \div y = r, \therefore m = rA,$$

is the specific moment of resistance about x , and when the direction of x varies, r varies in magnitude: r is called the "radius of resistance" of the cross section. The locus of the extremity of r , taken as a radius vector along the axis of solicitation, is called the "kernel."

The kernel is usually defined to be the locus of the center of action of a stress uniformly increasing from the tangent to the cross section at the extreme fiber. It was first pointed out by Jung,* and subsequently by Sayno, that the radius vector of the kernel is the radius of resistance of the cross section measured on the axis of solicitation. This will also appear from our construction by a method somewhat different from that heretofore employed.

Jung has also proposed to determine values of k , by first finding r ; and has given methods for finding r . We shall obtain r by a new method which renders the proposal of Jung in the highest degree useful.

The method heretofore employed by Culmann and other investigators has been to find values of k first, and then having drawn the ellipse of inertia to

construct the kernel as the locus of the antipole of the tangent at the extreme fiber. The method now proposed is the reverse of this, as it constructs several radii of the kernel first, then the corresponding radii of gyration, and from them the ellipse, and finally completes the kernel. In the old process there are inconvenient restrictions in the choice of pole distances which are entirely avoided in the new process.

Let the cross section treated be that of the T rail represented in Fig. 13, which is $4\frac{1}{2} \times 2\frac{1}{2}$ inches and $\frac{1}{2}$ inch thick. We have selected a rail of uniform thickness in order to avoid in this small figure the numerous lines needed in the summation polygon for determining the area; but any cross section can be treated with ease by using a summation polygon for finding the area.

To find the center of gravity, let the weights $w_1 w_2$ and $w_2 w_3$, which are proportional to the areas between the verticals at $b_1 b_2$ and $b_2 b_3$ be applied at their centers of gravity a_1 and a_2 respectively; then the equilibrium polygon $c_1 c_2$, having the pole p_1 , shows that o is the required center of gravity.

Let the area $b_2 b_3$ be divided into two parts at o , then $w_2 w_0$ and $w_0 w_3$ are weights proportional to the areas $b_2 o$ and $o b_3$ respectively; and $c_1 c_3 c_4$ is the equilibrium polygon for these weights applied at their centers of gravity a_3 and a_4 .

The intercepts mm have been previously shown to be proportional to the products of the applied weights by their distances from the center of gravity o .

We have heretofore spoken of these products as the moments of the weights about their common center of gravity o . But the weights in this case are areas and the product of an area by a distance is a volume. Let us for convenience call volumes so generated "stress solids." The elementary stress solids obtained by multiplying each elementary area by its distance from the neutral axis will correctly represent the stresses on the different parts of the cross section, and they will be contained between the cross section and a plane intersecting the cross section along the neutral axis and making an angle of 45° with the cross section.

If $b_1 b_3$ is the ground line, $b_1 b_2$ and $d_1 d_3$ are the traces of the planes between

* "Rappresentazioni grafiche dei momenti resistenti di una sezione piana." G. Jung, Rendiconti dell' Instituto Lombardo, Ser. 2, t. IX, 1876, No. XV. "Complemento alla nota precedente." No. XVI.

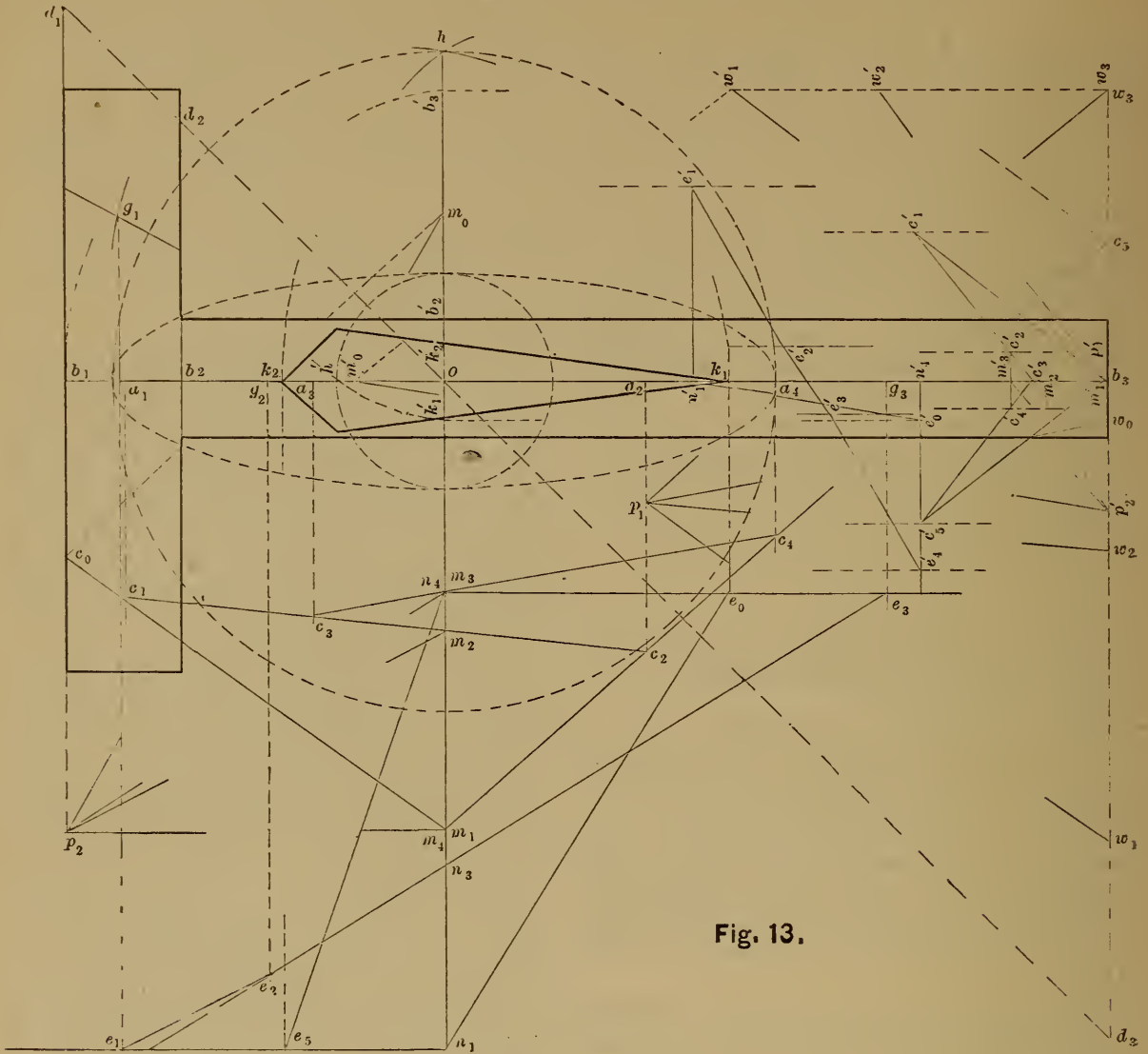

Fig. 13.

which the stress solid lies on a plane at right angles to the neutral axis.

The distances of the centers of gravity of the stress solids from o are also the distances of the points of application of the resultant stresses, and the magnitude of the resultant stresses are proportional to the stress solids. The stress solids may be considered to be some kind of homogeneous loading whose weight produces the stress upon the cross section. The moment of inertia I is the moment of this stress with respect to o .

Now the intercept m_3m_1 represents the weight of the stress solid whose profile is ob_3d_3 . Its point of application is g_3 , if $og_3 = \frac{2}{3}ob_3$. Similarly the weight m_2m_3 has its point of application at g_2 if $og_2 = \frac{2}{3}ob_2$. And the weight m_1m_2 is applied in the vertical through g_1 ; for the profile of this stress solid is the trapezoid $b_1b_2d_2d_1$, and g_1 is its center of gravity found geometrically. In case the

area is divided into narrow bands parallel to the neutral axis the points of application coincide sensibly with the centers of gravity of the bands.

Now take any pole p_2 and construct a second equilibrium polygon ee due to the stress solids applied in the verticals through $g_1g_2g_3$.

The last two sides e_1n_1 and e_3n_3 are necessarily parallel and have their intersection at infinity, for the total stress is a couple.

The intercept n_1n_3 is not drawn through the common center of gravity of the stress solids, *i. e.*, it is not an intercept on the line of the resultant stress, but since parallels are everywhere equidistant this intercept is proportional to the moment of the stresses about their center of gravity; in other words n_1n_3 when multiplied successively by the two pole distances would be I . We shall not need to effect the multiplication.

Prolong c_1m_1 to c_0 on the tangent to the extreme fiber and draw $c_0m_0 \parallel p_1w_3$, then m_1m_2 represents the product of the total weight-area w_1w_3 by $ob_1=y$ the distance of the extreme fiber, or m_1m_0 is proportional to the volume of a stress solid whose base is the entire cross section and whose altitude is $b_1d_1=ob_1$.

Suppose this stress to be of the same sign as that at the right of o , let us combine it with the stress already treated. Its point of application is necessarily at o , and its amount is m_1m_0 if measured on the same scale as the other stresses. Draw $n_1e_0 \parallel p_2m_0$, then is k_1 on the vertical through e_0 the point of application of the combined stresses. But the combined stresses amount to a stress whose profile is included between d_1d_3 and a horizontal line through d_1 , *i.e.* to a stress uniformly increasing from b_1 to b_3 ; hence k_1 is a point of the kernel as usually defined.

If c_4m_4 be prolonged to c_5 and we draw $c_5m_5 \parallel p_1w_1$, then m_4m_5 (not shown) is the weight of a stress solid of a uniform depth b_3d_3 over the entire cross section; and if we draw $n_4e_5 \parallel p_2m_5$, then will k_2 on the vertical through e_5 be also in like manner a point of the kernel, *i.e.* the point of application of a stress uniformly increasing from b_3 to b_1 .

But now let us examine our construction further in order to gain a more exact understanding of what the distances $r_1=ok_1$ and $r_2=ok_2$ signify.

We have shown that m_1m_0 represents the product of the area of the cross section by the distance ob_1 of the extreme fiber, *i.e.* the quantity Ay_1 ; but n_1n_4 represents the moment of this weight when applied at k_1 , *i.e.* the product Ay_1r_1 . Also as previously shown n_1n_4 represented I on the same scale, hence

$$I = Ay_1r_1, \text{ but } I = Ak_1^2 \therefore r_1 = k_1^2 \div y_1$$

and r_1 is the radius of resistance previously mentioned.

In order to determine the radius of gyration k_1 , which is a mean proportional between r_1 and y_1 , describe a circle on b_1k_1 as a diameter intersecting mm at h then $oh=k_1$ the semi-axis of the ellipse of inertia conjugate to mm as a neutral axis. The accuracy of the construction is tested by using b_3k_2 as a diameter and finding the mean proportional between ok_2 and ob_3 . It should give the same

result as that just obtained. In our Fig. both circles intersect at h .

It is known from the symmetry of figure of the cross section that k_1 is one of the principal axes.

In similar manner we construct the radius of resistance, etc., when b_1b_3 is taken as the neutral axis.

Knowing before hand that this line passes through the centre of gravity, we have taken the weights of the area above it in two parts, *viz.*: that extending from b_1b_2 , and that from b_2b_3 , and we have taken $w_1'w_2'$ and $w_2'w_3'$ respectively, as the weights of these. Choose any pole p_1' and draw the equilibrium polygon $c'e'$: use its intercepts $m'm'$, which represent the weights of stress solids, as weights and with any pole p_2' construct the second equilibrium polygon $e'e'$ on the verticals through the points of application of the stresses. Also find $m_1'm_0'$ the product of the total area by the distance of the extreme fiber and make $n_1'e_0' \parallel p_2'm_0'$; then is k_1' which is on the same vertical as e_0' a point of the kernel, and $ok_1'=r_1'$ the radius of resistance. Use $k_1'b_3'$ as a diameter, then is $oh'=k_1'$ the radius of gyration, for $k_1'^2=r_1'y_1'$.

With these two principal axes thus determined, it is possible at once to construct the ellipse of inertia. In any case it will be possible to determine the direction of the axis of solicitation corresponding to any assumed neutral axis by actual construction, it being simply necessary to find the line through o upon which lie the points of application of the positive and negative stresses considered separately. These axes being conjugate directions in the ellipse of inertia, when we have found the radii of resistance in those two directions we can at once obtain the corresponding radii of gyration which are conjugate semi-diameters, and so draw the ellipse.

After the ellipse is drawn the kernel can be readily completed by making r in every direction a third proportional to the distance of the extreme fiber and the radius of gyration.

We are assisted in drawing the kernel by noticing that to each straight side of the cross section there corresponds a single point in the kernel, and to each non-re-entrant angular point a side of the kernel, these standing in the mutual re-

lation of polar and anti-pole with respect to the ellipse of inertia, as shown by the equation $k^2 = ry$.

In Fig. 13 the point k_1 corresponds to the left hand vertical side, the point k_2 to the right hand vertical side, and the sides k_1k_1' , k_2k_2' to the angular points at the upper and lower extremities of the left side respectively, while the points

$k_1'k_2'$ at the very obtuse angular points of the kernel correspond to the upper and lower horizontal sides of the flange. The two remaining angular points of the kernel correspond to tangent lines when they just touch the corners of the flange and web, while the intermediate sides correspond to the angles at the extremities of these lines.

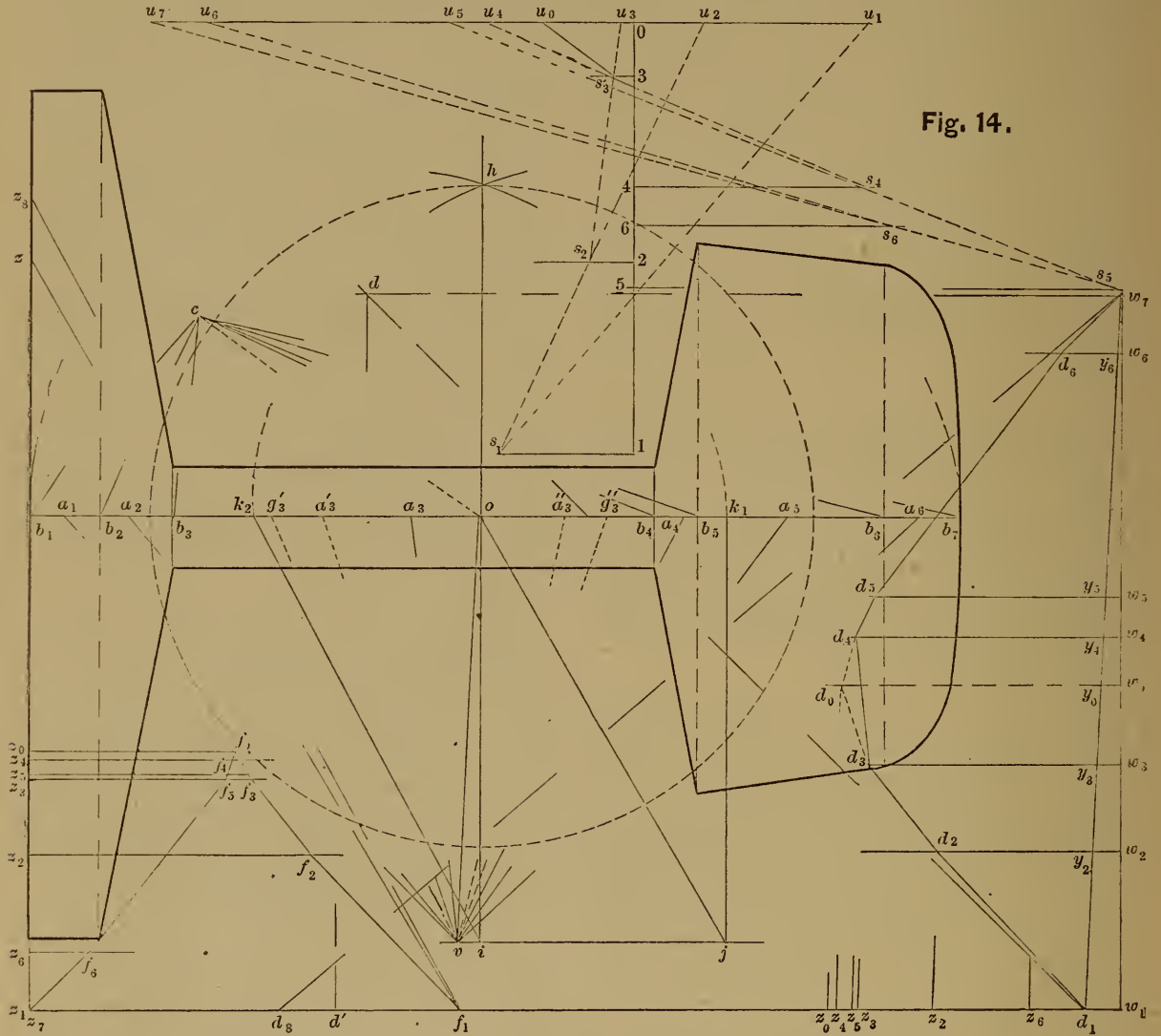

Fig. 14.

KERNEL, MOMENTS OF RESISTANCE AND INERTIA: FRAME PENCIL METHOD.

Let the cross section treated be that shown in Fig. 14, which is nearly that of a 56 lb. steel rail, the difference consisting only in a slight rounding at the angles.

Let the cross section be divided by lines perpendicular to the axis of symmetry bb at b_2, b_3 , etc., then the partial areas and the total area may be found by a summation polygon.

Take c as the common point of the

rays through b_1b_2 , etc., and make $01, 02$, etc., proportional to the mean ordinates of the areas standing on the bases b_1b_2, b_2b_3 , etc. respectively. Draw $s_1u_1 \parallel cb_1, s_2u_2 \parallel cb_2$, etc., then will the segments of the line wu represent the respective partial areas, and u_1u_7 will represent the total area.

Divide the vertical line wv into segments equal to those of the line nn , then is wv the weight line for finding the center of gravity, etc., of the cross section. Let a_1, a_2, a_3 , etc., be the centers

of gravity of the partial areas, and let v be the vertex of a frame pencil whose rays pass through these centers of gravity. Draw the equilibrating polygon dd with its sides parallel to the rays of this frame pencil, then the ray vo parallel to the closing side yy of the equilibrating polygon determines the center of gravity o of the cross section, according to principles previously explained.

It will be convenient to divide the cross section into two parts by the vertical line oi , which we shall take as the neutral axis. The partial areas b_3o and ob_4 have a_3' and a_3'' as their centers of gravity. Make $s_3u_0 \parallel co$, then w_0 which corresponds to u_0 , divides the weight line into two parts, representing the areas each side of the neutral axis, and the polygon dd can be completed by drawing $d_0d_3 \parallel va_3'$ and $d_0d_4 \parallel va_3''$. It has been previously shown that the abscissas yd represent the sum of the products of the weights (*i.e.* areas) by their distances from o ; and any single product is the difference of two successive abscissas. Project the lengths yd upon the horizontal zz by lines parallel to yy , then the segments of zz represent the products just mentioned. But these products are the stress solids or resultant stresses before mentioned. Hence zz is to be used as a weight line and is transferred to a vertical position at the left of the Fig. The points of application of the resultant stresses may without sensible error be taken at the centers of gravity a_1a_2 , etc., of the partial areas except in case of the segments of the web on each side of o . For these, let $og_3' = \frac{2}{3}ob_3$, and $og_3'' = \frac{2}{3}ob_4$, then g_3' and g_3'' are the required points of application.

Now with the weight line zz , which consists partly of negative loads, and with the same vertex v construct the second equilibrating polygon ff , then z_1f_1 represents the moment of inertia of the cross section, it being proportional the moment of the resultant stresses about o . It is seen that the sides f_3f_0 and f_0f_4 are so short that any small deviation in their directions would not greatly affect the result, and that there would therefore have been little error if the resultant stresses in the web had been applied at a_3' and a_3'' .

Again, draw $dd_1 \parallel vb_1$, then the hori-

zontal line $dw_1 (=d_1d')$ represents Ay_1 , the product of the total weight w_1w_7 (*i. e.* the total area of the cross section), by the distance of the extreme fiber $ob_1=y_1$. Use this as a stress solid or resultant stress applied at o and having a weight $zz_1=d_1d'$, and draw $oj \parallel zf_1$, j being at the same vertical distance from bb as v is; then is k_1 , which on the same vertical at j , a point of the kernel. For k_1 is such a point that the product of $ok_1 (=r_1)$ by the weight $zz_1 (=Ay_1)$ is $z_1f_1 = I$ on the same scale as I was previously measured.

Similarly draw $w_7d_8 \parallel vb_7$ and make $z_8z_1=d_1d_8$; also draw $ik_2 \parallel f_1z_8$: then is k_2 another point of the kernel as appears from reasons like those just given in case of k_1 .

Use b_1k_1 as a diameter, then oh is a semi-axis of the ellipse of inertia. The same point h should be found by using k_2b_7 as a diameter. Another semi-axis of the ellipse of inertia with reference to bb as a neutral axis, and conjugate to oh can be determined, using the same partial areas, by finding the centers of gravity and points of application of the stresses of the partial areas on one side of bb , the process being similar to that employed in Fig. 13, except in the employment of the frame pencil instead of the equilibrium polygon.

It is to be noticed that the closing side f_1z_1 of the second equilibrating polygon ff is parallel to a resultant ray which intersects bb at infinity, the point of application of the resultant of the applied stresses, *i. e.* the stresses form a couple.

When the ellipse of inertia has been found by determining the magnitude and direction of two conjugate axes, the kernel can be readily completed as has been shown in connection with Fig. 13.

UNIFORMLY VARYING STRESS IN GENERAL.

The methods employed in Figs. 13 and 14 are applicable also to any uniformly varying stress, for a stress which uniformly increases from any neutral axis x through the center of gravity of the cross section can be changed into a stress which uniformly increases from same parallel axis x' at a distance y_0 from x by simply combining with the former a stress uniformly distributed over the cross-section and of such intens-

ity as to make the resultant intensity zero along x' .

In the construction given in Figs. 13 and 14 it is only necessary to use the proposed line x' at a distance y_0 from o , instead of the tangent to the extreme fiber at a distance y_1 or y_2 from o , when we wish to determine the weight or volume of the resultant stress solid, its moment about o , and its center of gravity or application.

Since the locus of the center of application of the resultant stress is the anti-pole of x' with respect to the ellipse of inertia, it is evident that when the proposed axis x' lies partly within the cross section the center of application of the resultant stress is without the kernel, and that when x' is entirely without the cross section its center of application is within the kernel.

It is frequently more convenient to determine the center of application from the kernel itself than from the ellipse of inertia. This can be readily found from the equation which we are now to state

$$Ar_0y_0 = Ar_1y_1 = I,$$

in which equation Ay_0 and Ay_1 are the volumes of the stress solids which if uniformly distributed and compounded with the stress whose neutral axis is x , will cause the resultant stresses to vanish at distances y_0 and y_1 , respectively; while r_0 and r_1 are the distances from o of the respective centers of application of these stresses.

The truth of the equation is evident from the fact that the moment about o of any stress solid uniformly distributed is zero, hence the composition of such a stress with that previously acting will leave its moment unchanged.

From the equation just stated we have

$$y_0 : y_1 :: r_1 : r_0,$$

from which r_0 can be found by an elementary construction, since y_0 , y_1 and r_1 are known quantities. When it is desired to express these results in terms of the intensities of the actual stresses,

let $p_0 = ny_0$ be the mean stress; and let $p_1' = n(y_0 + y_1)$ be the greatest, and let $p_2' = n(y_0 - y_2)$ be the least intensity at the extreme fiber:

then $ny_1 = p_1' - ny_0 = p_1' - p_0$

or $ny_2 = ny_0 - p_2' = p_0 - p_2'$

$\therefore p_0 : p_1' - p_0 :: r_1 : r_0$

or $p_0 : p_0 - p_2' :: r_2 : r_0$

in which r_1 and r_2 are the two radii of the kernel.

DISTRIBUTION OF SHEARING STRESS.

It is well known that the equation $dM = Tdz$, expresses the relation of the total shearing stress T sustained at any cross section of a girder to the variation dM of the bending moment M at a parallel cross-section situated at the small distance dz from the first mentioned cross section.

We have already treated the normal components of the stress caused by the bending moment M : we shall now treat the tangential component or shear which accompanies any variation of the bending moment.

We shall assume as already proved the following equation* which expresses the intensity q of the shearing stress at any point of the cross section:

$$Iqx = TV$$

in which x is the width of the girder measured parallel to the neutral axis at any distance y from the neutral axis, and q is the intensity of the shearing stress at the same distance, I is the moment of inertia of the cross section about the neutral axis, T is the total shear at this cross section, and V is the volume of that part of one of the stress solids used in finding the moment of inertia which is situated at a greater distance than y from the neutral axis, *i.e.* in Fig. 13 if we were finding the value of q at b_2 , with respect to om_3 as the neutral axis, then V would signify the stress solid whose profile is $d_1d_2b_2b_1$. It, however, makes no difference whether we define V as the stress solid situated at the left or at the right of b_2 ; for, since the total stress solid, positive and negative, is zero, that on either side of any assumed plane is the same.

The first step in our process is to find the intensity of the shear at the neutral axis, which we denote by q_0 ; and if we also call x_0 the width here and V_0 the volume of either of the two equal stress

* See Rankine's Applied Mechanics. Eighth Edition, Art. 309, p. 333.

solids between this axis and the extreme fiber, we have

$$Iq_0x_0 = TV_0, \text{ but } I = V_0d$$

when d is the distance between the centers of application of the equal stress solids, *i.e.*, d is the arm of the couple of the resultant stresses. Also $T = A\bar{q}$ when A is the total area of the cross section and \bar{q} is the mean intensity of the shearing stress. Hence at the neutral axis we have the equation

$$q_0x_0d = A\bar{q} = T$$

Now the length of the arm d is found in Fig. 13 by prolonging the middle side (*i.e.* the side through n_3) of the second equilibrium polygon until it intersects the first side and the last. These intersections will give the position of the centers of gravity of the stress solids on either side of o .

In Fig. 14 the same points are found by drawing rays from v parallel respectively to z_1f_0 and f_1f_0 until they intersect aa .

In Fig. 15 the points f_1 and f_2 are found by either of these methods and $f_1f_2 = d$ is the required distance.

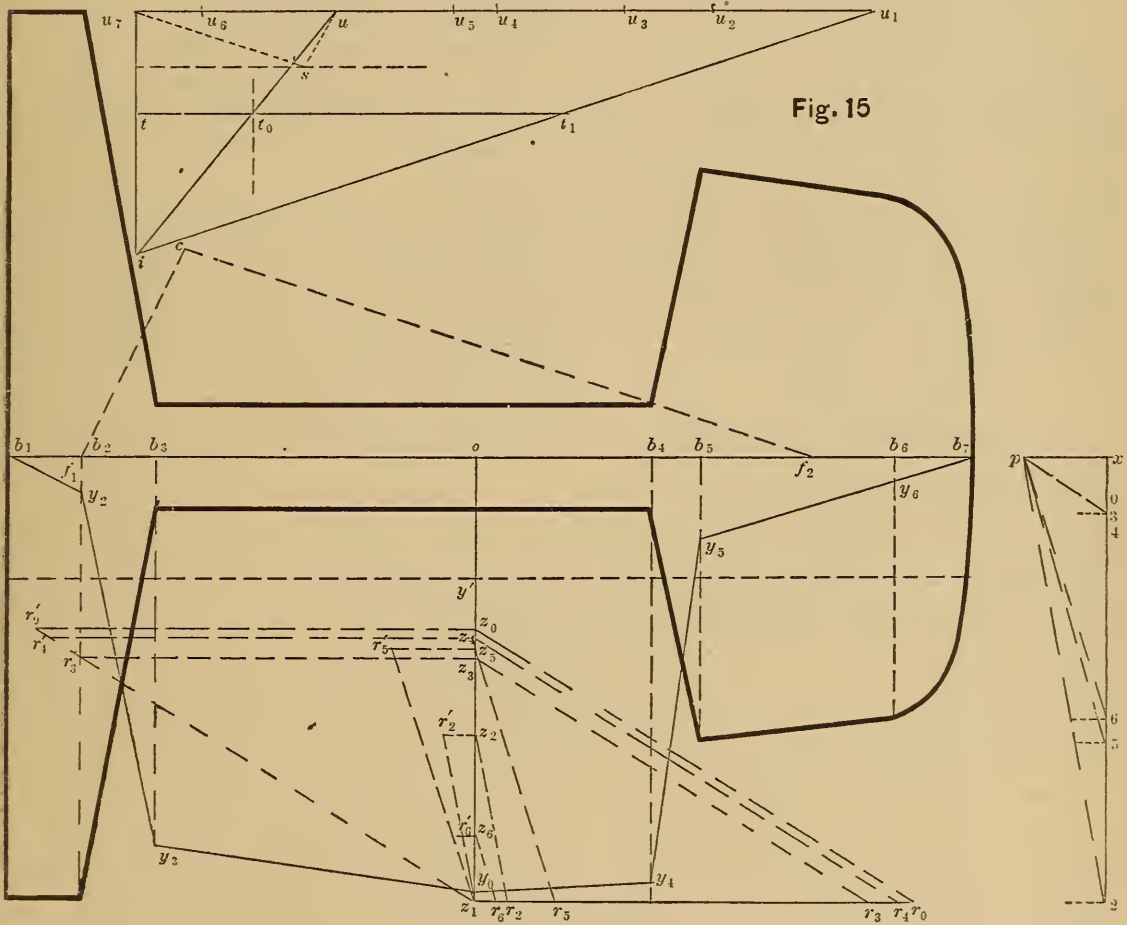

Fig. 15

Now in Fig. 15 let the segments uu of the summation polygon be obtained just as in Fig. 14, and parallel to uu draw a line through s representing the width of the cross section x_0 on the same scale as before used in constructing the summation polygon. Also make $su_7 \parallel cf_2$ and $su \parallel cf_1$, c being the common point in the rays of the pencil of the summation polygon for finding the area.

Then uu_7 represents the product x_0d on same scale that u_1u_7 represents A .

Now draw from any point i rays to u_1 , u and u_7 , and also a parallel to iu_7 at a distance \bar{q} and intersecting iu at some point t_0 such that $tt_0 = \bar{q}$ to such a scale as may be convenient. The mean intensity \bar{q} is supposed to be a known quantity, and $tt_0 \parallel uu$. Then from the proposed equation we have the proportion

$$x_0d : A :: \bar{q} : q_0$$

$$uu_7 : u_1u_7 :: tt_0 : tt_1$$

or

Hence tt_1 represents the intensity of the shearing stress at the neutral axis on the same scale that tt_0 represents the mean intensity.

This first step of our process has determined the intensity of the stress at the neutral axis relatively to the mean stress; the second step will determine the intensity of the stress at any other point relatively to the stress at the neutral axis. When this last point is all that is desired the first step may be omitted.

The equation $Ixq = TV$ may be written $xq = cV$, in which $c = T \div V$ is a constant. At the neutral axis this equation is

$$x_0q_0 = cV_0 \text{ or } V_0 : q_0 :: x_0 : c$$

In Fig. 15 lay off the segments of the line zz just as in Fig. 14; then z_1z_0 represents the weight or volume V_0 ; also make x_0, x_2, x_3 , etc., proportional to width of the girder at o, b_2, b_3 , etc., and lay off $z_1r_0 = z_0r'_0 = tt_1$.

Draw $p_0 \parallel r_0z_0$, then by similar triangles

$$z_1z_0 : z_1r_0 :: x_0 : xp$$

or $V_0 : q_0 :: x_0 : c$

$\therefore px$ represents the constant c .

Now the several segments z_1z_2, z_1z_3, z_1z_4 , etc., represent respectively the values of V_2, V_3, V_4 , or the stress solids between one extreme fiber and b_2, b_3, b_4 , etc.; it is of no consequence which extreme fiber is taken as the stress solid is the same in either case.

Now using p as a pole draw rays to 2 3 4 5 etc., and make $z_2r_2 \parallel p2, z_3r_3 \parallel p3$, etc., then by similar triangles

$$z_1z_2 : z_1r_2 :: x_2 : c, \text{ or } x_2q_2 = cV_2$$

and $z_1z_3 : z_1r_3 :: x_3 : c, \text{ or } x_3q_3 = cV_3$

etc., etc., and z_1r_2, z_1r_3 , etc., represent the intensity of the shearing stresses at b_2, b_3 , etc. These can be constructed equally well by drawing rays from z_1 parallel to the rays at p , from which we obtain

$$z_2r'_2 = z_1r_2, z_3r'_3 = z_1r_3, \text{ etc.}$$

Now lay off $b_2y_2 = z_1r'_2, b_3y_3 = z_1r'_3$, etc., then the ordinates by of the polygon yy represent the intensity of the shearing stress on the same scale that $tt_1 = z_1r_0$ represents the intensity q_0 at the neutral axis, and on the same scale that $tt_0 = oy'$ represents the mean intensity \bar{q} . The

lines joining y_2, y_3 , etc., should be slightly curved, but when they are straight the representation is quite exact.

RELATIVE STRESSES.

It is proposed here to develop a new construction which will exhibit the relative magnitude of the normal components of the stresses produced by a given system of loading in the various cross-sections of a girder having a variable cross section. The value of such a construction is evident, as it shows graphically the weakest section, and investigates the fitness of the assumed disposition of the material for sustaining the given system of loading.

The constructions heretofore given for the kernel and moments of resistance at any given cross section admit of the immediate comparison of the normal components of the stresses produced in that single cross section when different neutral axes are assumed, but by this proposed construction, a comparison is effected between these stresses at any different cross sections of the same girder or truss.

In the equation previously used

$$M = SI \div y = SAk^2 \div y = SA_r$$

in which M is the moment of flexure which produces the stress S in the extreme fiber of a cross section whose area is A and whose radius of resistance is r , we see, since the specific moment of resistance $m = Ar$ is the product of two factors, that the same product can result from other and very different factors.

For example, let $m = A_0r'$ in which A_0 is the area of some cross section which is assumed as the standard of comparison, and $r' = Ar \div A_0 = ar$, when $a = A \div A_0$. Then is A_0r' the specific moment of resistance of a cross section of an assumed area A_0 which has a different disposition of material from that whose specific moment of resistance is Ar , but the cross sections A and A_0 are equivalent to each other in this sense, that they have the same specific resistance, and consequently the same bending moment will produce equal stresses in the extreme fiber in each.

The two cross sections do not have the same moment of inertia, and so the deflections of the girder would be

changed by substituting one cross section for the other. We shall then speak of them as equivalent only in the former sense, and on the basis of this definition, state the result at which we have arrived thus: Equivalent cross sections under the action of the same bending moment, have the same stresses at the extreme fiber (though they are not equally stiff); hence in comparing stresses equivalent cross sections may be substituted for each other (but they may not be so substituted in comparing deflections).

It is proposed to utilize this result by substituting for any girder or truss having a variable cross section A or a variable specific moment of resistance whose magnitude is expressed by the variable quantity Ar , a different one having a cross section everywhere of constant

area A_0 , but of such disposition of material that its specific moment of resistance is $A_0 r' = Ar$ at corresponding cross sections.

The proposed substitution is especially easy in case of a truss, for in it the value of r varies almost exactly as its depth, as may be seen when we compute the value of $m = Ak^2 \div y = Ar$ in this case.

Since the material which resists bending is situated in the chords alone and is all approximately at the same distance from the neutral axis we have $k = y = r = \frac{1}{2}h$ very nearly when h is the distance between the chords, $\therefore m = \frac{1}{2}Ah$ nearly. Even when the two chords are of unequal cross section and the neutral axis not midway between them the same result holds when the ratio of the two cross sections is constant.

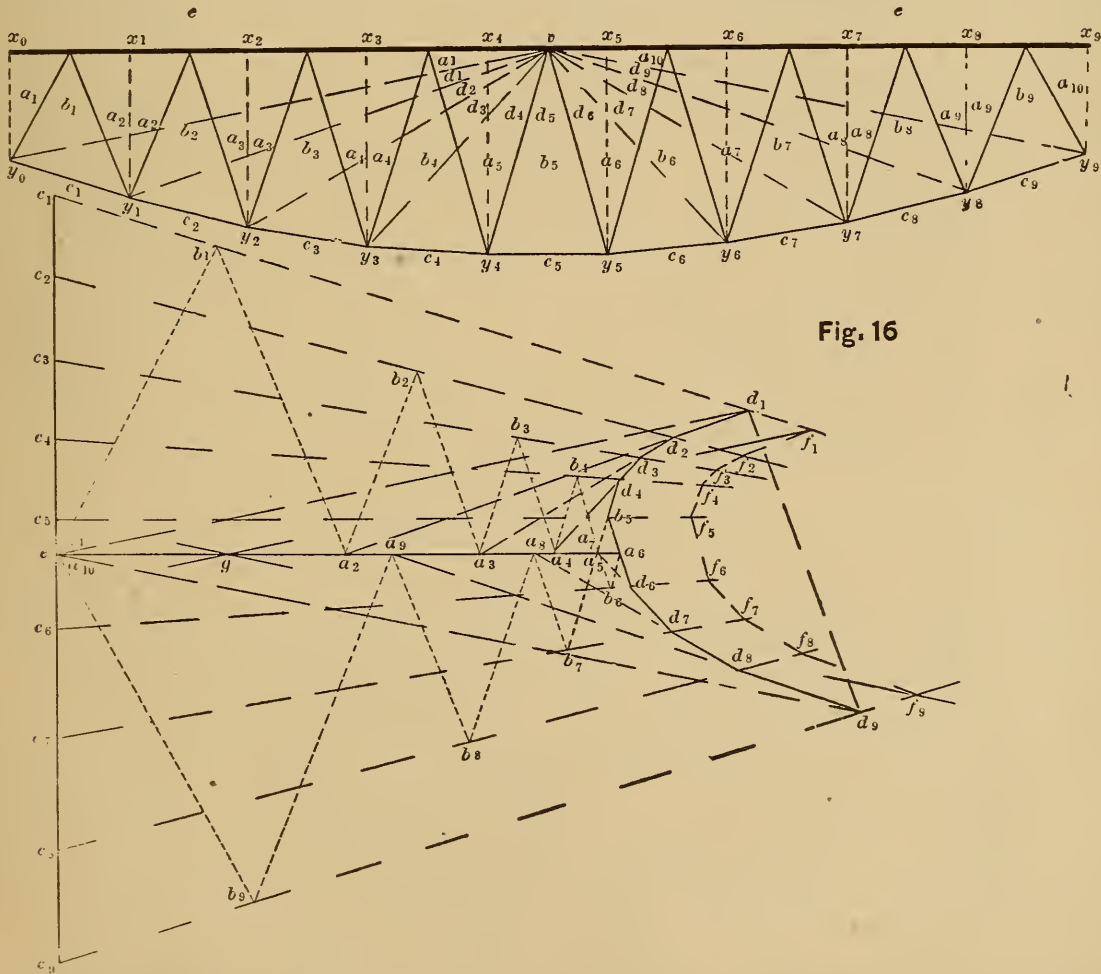

Fig. 16

In Fig. 16 let xx be the axis of a girder sustaining at the points x_1, x_2 , etc., the weights c_1, c_2, c_3 , etc. Lay off the ordinates xy at each of the points at which weights are applied, so that $xy = Ar$ on some assumed scale; then since

$A_0 r' = Ar = xy$, xy varies as r' , the radius of resistance of a girder having at every point a cross section A_0 so disposed as to be equivalent to that of the given girder xx .

Assume some form of framing con-

necting the points xy as shown in the Fig., and suppose the weights applied at the points yy of the lower chord, the points of support being at y_0 and y_3 . Then by a method like that employed in Fig. 3, we obtain the total stresses $ea_2, ea_3, ea_4, \text{ etc.}$, in the segments of the upper chord which are opposite to $y_1, y_2, y_3, \text{ etc.}$ Now these total stresses are resisted by a cross section of constant area A_0 , consequently they have the same ratio to one another as the intensities per square unit; or further, they represent, as we have just shown, the relative intensities of the stresses on the extreme fiber of the given girder.

It is well known from mechanical considerations, that the stress in the several segments of the upper chord is

dependent upon the loading and upon the position of $y_1, y_2, \text{ etc.}$, and is not dependent upon the position of the joints in the upper chord. Of this fact we offer the following geometrical proof derived from the known relations between the frame and force polygons.

We know, if any joint of the upper chord, such as ea_2b_1 for example, be removed to a new position, such as v , that so long as the weights $c_1c_2, c_2c_3, \text{ etc.}$, are unchanged, that the vertex b_1 of the triangle ea_2b_1 in the force polygon must be found on the force line $c_1f_1 \parallel y_0y_1$. We shall show that while the side ea_2 is unchanged, the locus of b_1 is the force line c_1f_1 ; hence conversely, so long as c_1f_1 is the locus of b_1 , ea_2 is unchanged, since there can be but one such triangle.

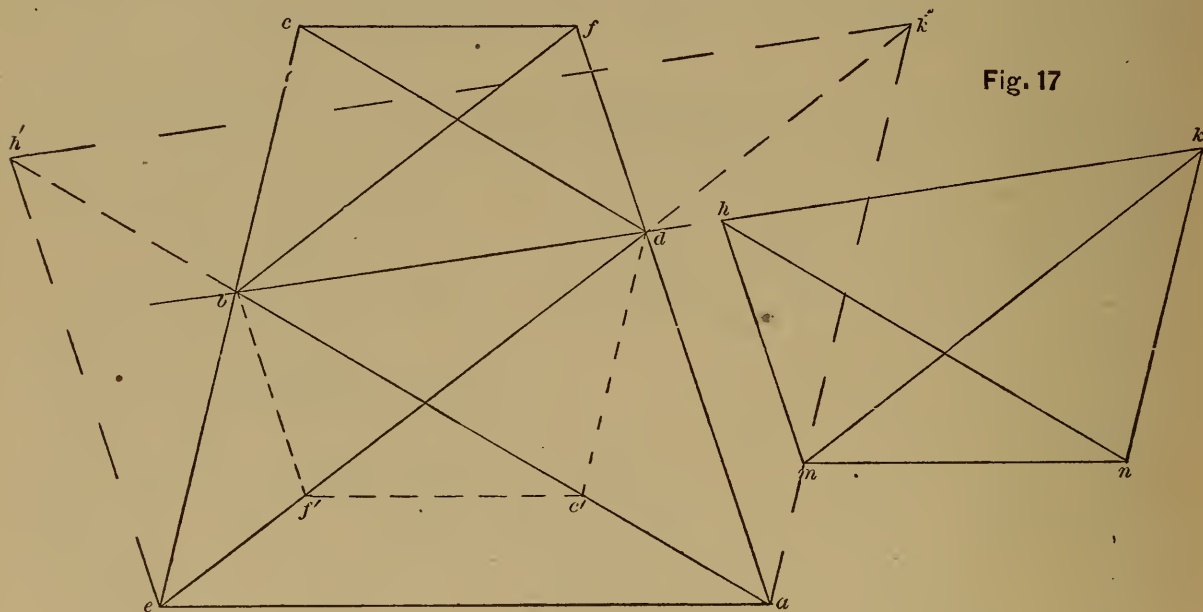

Fig. 17

In Fig. 17 let the two triangles abe, hnk , have the sides meeting at b and n mutually parallel. Let the bases ae and hk be invariable but let the vertex b be removed to any point d such that $bd \parallel hk$, then will the vertex n be removed to a point m such that $mn \parallel ae$.

For, prolong ad and eb , and draw $bf \parallel ed$ and $dc \parallel ab$, then is $abfcddea$ a hexagon inscribed in the conic section consisting of the two lines af and ec , hence by Pascal's Theorem, the opposite diagonals ea and cf intersect on the same line as the remaining pairs of opposite diagonals, $ab \parallel dc$ and $ed \parallel bf$. But this line is at infinity, hence $cf \parallel ae$. Also $c'f' \parallel cf$, from elementary considerations; and $c'f' \parallel mn$ from similarity of

figures, hence $mn \parallel ae$. There are two cases, according as mn is above or below bk , but we have proved them both.

Now in Fig. 16 let all the joints in the upper chord be removed to v , then the segments $ea_2, a_2a_3, \text{ etc.}$, are unchanged, hence $ea_3, ea_4, \text{ etc.}$ are unchanged, and the assumed framing reduces to the frame pencil whose vertex is v . The corresponding force polygon is the equilibrating polygon dd .

Hence the frame pencil can be used as the assumed framing just as well as any other form of framing, and it is unnecessary to use any construction except that of the frame pencil and equilibrating polygon for finding the relative stresses $ea_2, ea_3, \text{ etc.}$

STRESSES IN A HORIZONTAL CHORD.

If Fig. 16 be regarded as representing an actual bridge truss, whose chords are not of uniform cross section; it is seen that the total stresses on the horizontal chord are given by the segments ea_2 , ea_3 , etc., which are found from the equilibrating polygon alone without regard to the kind of bracing in the truss, which it is unnecessary to consider; and this method can be used to take the place of that given in connection with Fig. 3 for finding the maximum stresses on the chords.

The equilibrating polygon ff was constructed to determine the reactions of the piers by finding the point e . The outer sides of the polygon ff intersect at g which determines e as explained in Fig. 7 in a manner different from that given in Fig. 3.

This construction sheds new light upon the significance of the frame pencil and equilibrating polygon. The frame pencil is the limiting case of a truss when the joints along one chord are removed to a single point, so that each ray may be regarded as compounded of a tension member and a compression member, having the same direction, *e.g.*, the tension member of which y_1v is compounded has the stress d_1a_2 , and the compression member the stress d_2a_2 , but if the two be combined, the resultant tension is d_1d_2 .

In case yy is the equilibrium curve due to the applied weights, and v falls upon the closing line, the force lines cd meet at the pole and the lines ed_1 , ed_2 , coincide with aa , so that the polygon dd is at the pole and infinitely small, and the stress in every segment of the upper chord is equal to the pole distance de .

NOTE A.

ADDENDUM TO PAGE 12, CHAPTER I.

The truth of Proposition IV is, perhaps, not sufficiently established in the demonstration heretofore given. As it is a fundamental proposition in the graphical treatment of arches, and as it is desirable that no doubt exist as to its validity, we now offer a second proof of it, which, it is thought, avoids the difficulties of the former demonstration.

Prop. IV. If in any arch that equilibrium polygon (due to the weights) be constructed which has the same horizontal thrust as the arch actually exerts; and if its closing line be drawn from considerations of the conditions imposed by the supports, etc.; and if, furthermore, the curve of the arch itself be regarded as another equilibrium polygon due to some system of loading not given, and its closing line be also found from the same considerations respecting supports, etc.; then when these two polygons are so placed that their closing lines coincide, and their areas partially cover each other, the ordinates intercepted between these two polygons are proportional to the real bending moments acting in the arch.

The bending moments at every point of an arch are due to the applied forces and to the shape of the arch itself.

The applied forces are these: the vertical forces, which comprise the loading and the vertical reactions of the piers; the horizontal thrust; and the bending moments at the piers, caused by the constraint at these points of sup-

port. The loading may cause all the other applied forces or it may not: in any case the bending moments are unaffected by the dependence or want of dependence of the thrust, etc., upon the loading.

Now, so far as the loading and the moments due to the constraint at the piers are concerned, they cause the same bending moments at any point of the arch as they would when applied to a straight girder of the same span, for neither are the forces nor their arms different in the two cases.

But the horizontal thrust, which is the same at every point of the arch, causes a bending moment proportional to its arm, which is the distance of its line of application from the curve of the arch. This line of application is known to be the closing line; hence the ordinates which represent the bending moments due to the horizontal thrust, are included between the curve of the arch and a closing line drawn in such a manner as to fulfill the conditions imposed by the joints or kind of support at the piers, hence the curved neutral axis of the arch is the equilibrium or moment polygon due to the horizontal thrust.

But the same conditions fix both the closing line of the equilibrium polygon which represents the bending moments due to the loading and to the constraint at the piers, and the closing line of the equilibrium polygon due to the horizontal thrust. Hence the resultant bending moment is found by taking the difference of the ordinates at each point, or by laying them off from one and the same closing line exactly as described in the statement of our proposition.

THE THEORY OF INTERNAL STRESS

IN

GRAPHICAL STATICS.

THE THEORY OF INTERNAL STRESS

IN

GRAPHICAL STATICS.

STRESS includes all action and reaction of bodies and parts of bodies by attraction of gravitation, cohesion, electric repulsion, contact, etc., viewed especially as distributed among the particles composing the body or bodies. Since action and reaction are necessarily equal, stress is included under the head of Statics, and it may be defined to be the equilibrium of distributed forces.

Internal stress may be defined as the action and reaction of molecular forces. Its treatment by analytic methods is necessarily encumbered by a mass of formulæ which is perplexing to any except an expert mathematician. It is necessarily so encumbered, because the treatment consists in a comparison of the stresses acting upon planes in various directions, and such a comparison involves transformation of quadratic functions of two or three variables, so that the final expressions contain such a tedious array of direction cosines that even the mathematician dislikes to employ them.

Now, since the whole difficulty really lies in the unsuitability of Cartesian coordinates for expressing relations which are dependent upon the parallelogram of forces, and does not lie in the relations themselves, which are quite simple, and, which no doubt, can be made to appear so in quaternion or other suitable notation; it has been thought by the writer that a presentation of the subject from a graphical stand point would put the

entire investigation within the reach of any one who might wish to understand it, and would also be of assistance to those who might wish to read the analytic investigation.

The treatment consists of two principal parts: in the first part the inherent properties of stress are set forth and proved by a general line of reasoning which entirely avoids analysis, and which, it is hoped, will make them well understood; the second part deals with the problems which arise in treating stress. These problems are solved graphically, and if analytic expressions are given for these solutions, such expressions will result from elementary considerations appearing in the graphical solutions. The constructions by which the solutions are obtained are many of them taken from the works of the late Professor Rankine, who employed them principally as illustrations, and as auxiliary to his analytic investigations.

It is thus proposed to render the treatment of stress exclusively graphical, and by so doing to add a branch to the science of Graphical Statics, which has not heretofore been recognized as susceptible of graphical treatment. It seems unnecessary to add a word as to the importance, not to say necessity, to the engineer of a knowledge of the theory of combined internal stress, since all correct designing presupposes such knowledge.

STRESS ON A PLANE.—“If a body be conceived to be divided into two parts by an ideal plane traversing it in any direction, the force exerted between those two parts at the plane of division is an *internal stress*.”—Rankine.

A STATE OF INTERNAL STRESS is such a state that an internal stress is or may be exerted upon every plane passing through a point at which such a state exists.

It is assumed as a physical axiom that the stress upon an ideal plane of division which traverses any given point of a body, cannot change suddenly, either as to direction or magnitude, while that plane is gradually turned in any way about the given point. It is also assumed as axiomatic that the stress at any point upon a moving plane of division which undergoes no sudden changes of motion, cannot change suddenly either as to direction or amount. A sudden variation can only take place at a surface where there is a change of material.

GENERAL PROPERTIES OF PLANE STRESS.

We shall call that stress a *plane stress* which is parallel to a plane; e.g., let the plane of the paper be this plane and let the stress acting upon every ideal plane which is at right angles to the plane of the paper be parallel to the plane of the paper, then is such a stress a plane stress.

The *obliquity* of a stress is the angle included between the direction of the stress and a line perpendicular to the ideal plane it acts upon. This last plane we shall for brevity call the *plane of action* of the stress, and any line perpendicular to it, its *normal*. In plane stress, the planes of action are shown by their traces on the plane of the paper, and then their normals, as well as their directions, the magnitudes of the stresses, and their obliquities are correctly represented by lines in the plane of the paper.

The definition of stress which has been given is equivalent to the statement that stress is *force* distributed over an area in such wise as to be in equilibrium.

In order to measure stress it is necessary to express its amount per unit of

area: this is called the *intensity* of the stress.

Stress, like force, can be resolved into components. An oblique stress can be resolved into a component perpendicular to its plane of action called the *normal component*, and a component along the plane called the *tangential component* or *shear*.

When the obliquity is zero, the entire stress is normal stress, and may be either a compression or a tension, i.e., a thrust or a pull. When the obliquity is $\pm 90^\circ$, the stress consists entirely of a tangential stress or shear. If a compression be considered as a positive normal stress, it is possible to consider a normal tension as a stress whose obliquity is $\pm 180^\circ$, and the obliquities of two shears having opposite signs, also differ by 180° .

Fig. 1

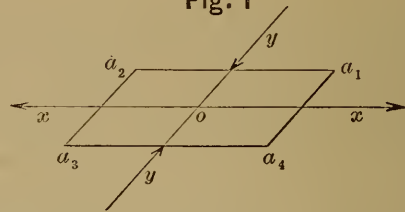

CONJUGATE STRESSES.—If in Fig. 1 any state of stress whatever exists at o , and xx be the direction of the stress on a plane of action whose trace is yy , then is yy the direction of the stress at o on the plane whose trace is xx . Stresses so related are said to be *conjugate stresses*.

For consider the effect of the stress upon a small prism of the body of which $a_1a_2a_3a_4$ is a right section. If the stress is uniform that acting upon a_1a_4 is equal and opposed to that acting upon a_2a_3 , and therefore the stress upon these faces of the prism are a pair of forces in equilibrium. Again, the stresses upon the four faces form a system of forces which are in equilibrium, because the prism is unmoved by the forces acting upon it. But when a system of forces in equilibrium is removed from a system in equilibrium, the remaining forces are in equilibrium. Therefore the removal of the pair of stresses in equilibrium acting upon a_1a_4 and a_2a_3 from the system of stresses acting upon the four faces, which are also in equilibrium, leaves the stresses upon a_1a_2 and a_3a_4 in equilibrium. But if the stress is uniform, the stresses on a_1a_2 and a_3a_4 must

be parallel to yy , as otherwise a couple must result from these equal but not directly opposed stresses, which is inconsistent with equilibrium.

This proves the fact of conjugate stresses when the state of stress is uniform: in case it varies, the prism can be taken so small that the stress is sensibly uniform in the space occupied by it, and the proposition is true for varying stress in case the prism be indefinitely diminished, as may always be done.

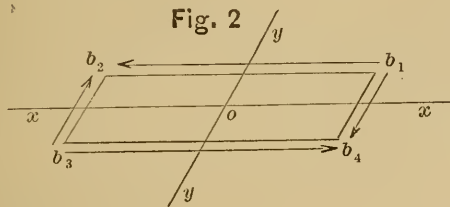

Fig. 2

TANGENTIAL STRESSES.—If in Fig. 2 the stress at o on the plane xx is in the direction xx , *i.e.* the stress at o on xx consists of a shear only; then there necessarily exists some other plane through o , as yy , on which the stress consists of a shear only, and the shear upon each of the planes xx and yy is of the same intensity, but of opposite sign.

For let a plane which initially coincides with xx revolve continuously through 180° about o , until it again coincides with xx , the obliquity of the stress upon this revolving plane has changed gradually during the revolution through an angle of 360° , as we shall show.

Since the obliquity is the same in its final as in its initial position, the total change of obliquity during the revolution is 0° or some multiple of 360° . It cannot be 0° , for suppose the shear to be due to a couple of forces parallel to xx , having a positive moment; then if the plane be slightly revolved from its initial position in a plus direction, the stress upon it has a small normal component which would be of opposite sign, if the pair of forces which cause it were reversed or changed in sign; or, what is equivalent to that, the sign of the small normal component would be reversed if the plane be slightly revolved from its initial position in a minus direction. Hence the plane xx , on which the stress

is a shear alone, separates those planes through o on which the obliquity of the stress is greater than 90° from those on which it is less than 90° , *i.e.*, those having a plus normal component from those having a minus normal component.

Since in revolving through $+180^\circ$ the plane must coincide, before it reaches its final position, with a plane which has made a slight minus rotation, it is evident that the sign of the normal component changes at least once during a revolution of 180° . But a quantity can change sign only at zero or infinity, and since an infinite normal component is inadmissible, the normal component must vanish at least once during the proposed revolution. Hence the obliquity is changed by 360° or some multiple of 360° while the plane revolves 180° . In fact the normal component vanishes but once, and the obliquity changes by once 360° only, during the revolution.

It is not in every state of stress that there is a plane on which there is no stress except shear, but, as just shown, when there is one such plane xx there is necessarily another yy , and all planes through o and cutting the angles in which are b_1 and b_3 have normal components of opposite sign from planes through o and cutting the angles in which are b_2 and b_4 .

To show that the intensity of the shear on xx is the same as that on yy , consider a prism one unit long and having the indefinitely small right section $b_1b_2b_3b_4$. Let the area of its upper or lower face be $a_1 = b_1b_2$, that of its right or left face be $a_2 = b_2b_3$, then a_1s_1 and a_2s_2 are the total stresses on these respective faces if s_1 and s_2 are the intensities of the respective shears per square unit. Let the angle $xoy = i$, then

$$a_1s_1 \cdot a_2 \sin. i$$

is the moment of the stresses on the upper and lower faces of the prism, and

$$a_2s_2 \cdot a_1 \sin. i$$

is the moment of the stresses on the right and left faces; but since the prism is unmoved these moments are equal.

$$\therefore s_1 = s_2$$

These stresses are at once seen to be of opposite sign.

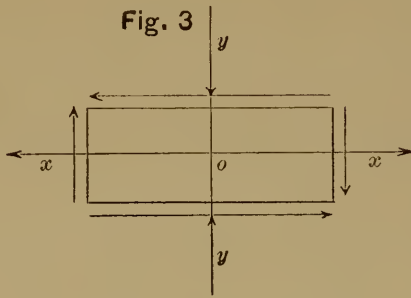

TANGENTIAL COMPONENTS.—In Fig. 3 if xx and yy are any two planes at right angles to each other, then the intensity at o of the tangential component of the stress upon the plane xx is necessarily the same as that upon the plane yy , but these components are of opposite sign.

For the normal components acting upon the opposite faces of a right prism are necessarily in equilibrium, and by a demonstration precisely like that just employed in connection with Fig. 2 it is seen that for equilibrium it is necessary and sufficient that the intensity of the tangential component on xx be numerically equal to that on yy , but of opposite sign.

STATE OF STRESS.—In a state of plane stress, the state at any point, as o , is completely defined, so that the intensity and obliquity of the stress on any plane traversing o can be determined, when the intensity and obliquity of the stress on any two given planes traversing that point are known.

For suppose in Fig. 4 that the intensity and obliquity of the stress on the given planes xx and yy are known, to find that on any plane $x'a'$ draw $mn \parallel x'a'$ then the indefinitely small prism one unit in length whose right section is mno , is held in equilibrium by the forces acting upon its three faces. The forces acting upon the faces om and on are known in direction from the obliquities of the stresses, and, if p_x and p_y are the respective intensities of the known stresses, then the forces are $om.p_x$ and $on.p_y$ respectively. The resultant of these forces and the reaction which holds it in equilibrium, together constitute the stress acting on the face mn : this resultant divided by mn is the intensity of the stress on mn and its

direction is that of the stress on mn or $x'a'$.

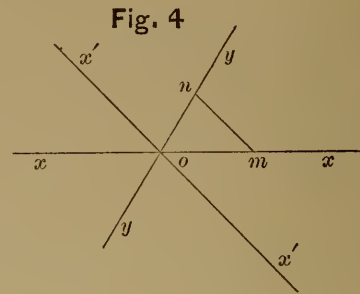

It should be noticed that the stress at o on two planes as xx and yy cannot be assumed at random, for such assumption would in general be inconsistent with the properties which we have shown every state of stress to possess. For instance we are not at liberty to assume the obliquities and intensities of the stresses on xx and yy such that when we compute these quantities for any plane $x'a'$ and another plane $y'y'$ at right angles to $x'a'$ in the manner just indicated, it shall then appear that the tangential components are of unequal intensity or of the same sign. Or, again, we are not at liberty to so assume these stresses as to violate the principle of conjugate stresses.

But in case the stresses assumed are conjugate, or consist of a pair of shears of equal intensity and different sign on any pair of planes, or in case any stresses are assumed on a pair of planes at right angles such that their tangential components are of equal intensity but different sign, we know that we have made a consistent assumption and the state of stress is possible and completely defined.

The state of stress is not completely defined when the stress upon a single plane is known, because there may be any amount of simple tension or compression along that plane added to the state of stress without changing either the intensity or obliquity of the stress on that plane.

PRINCIPAL STRESSES.—In any state of stress there is one pair of conjugate stresses at right angles to each other, *i.e.* there are two planes at right angles on which the stresses are normal only. Stresses so related are said to be *principal stresses*.

It has been previously shown that if a plane be taken in any direction, and the direction of the stress acting on it be found, then these are the directions of a pair of conjugate stresses of which either may be taken as the plane of action and the other as the direction of the stress acting upon it.

Consider first the case in which the state of stress is defined by a pair of conjugate stresses of the same sign; *i.e.*, the normal components of this pair of conjugate stresses are both compressions or both tensions.

It is seen that they are of opposite obliquities, and if a plane which initially coincides with one of these conjugate planes of action be continuously revolved until it finally coincides with the other, the obliquity must pass through all intermediate values, one of which is 0° , and when the obliquity is 0° the tangential component of the stress vanishes. But as has been previously shown there is another plane at right angles to this which has the same tangential component; hence the stress is normal on this plane also.

Consider next the case in which the pair of conjugate stresses which define the state of stress are of opposite sign, *i.e.*, the normal component on one plane is a compression and that on the other a tension.

In this case there is a plane in some intermediate position on which the stress is tangential only, for the normal component cannot change sign except at zero. It has been previously shown that in case there is one plane on which the stress is a shear only, there is another plane also on which the stress is a shear only, and that this second shear is of equal intensity with the first but of opposite sign. Let us consider then that the state of stress, in the case we are now treating, is defined by these opposite shears instead of the conjugate stresses at first considered.

Now let a plane which initially coincides with one of the planes of equal shear revolve continuously until it finally coincides with the other. The obliquity gradually changes from $+90^\circ$ to -90° , during the revolution, hence at some intermediate point the obliquity is 0° ; and since the tangential component has the same intensity on a plane at right

angles to this, that is another plane on which the obliquity of the stress is also 0° .

We have now completely established the proposition respecting the existence of principal stresses which may be restated thus:

Any possible state of stress can be completely defined by a pair of normal stresses on two planes at right angles to each other.

As to the direction of these principal planes and stresses, it is easily seen from considerations of symmetry that in case the state of stress can be defined by equal and opposite shears on a pair of planes, that the principal planes bisect the angles between the planes of equal shear, for there is no reason why they should incline more to one than to the other. We have before shown that the planes of equal shear are planes of separation between those whose stresses have normal components of opposite sign: hence it appears that the principal stresses are of opposite sign in any state of stress which can be defined by a pair of equal and opposite shears on two planes.

It will be hereafter shown how the direction and magnitude of the principal stresses are related to any pair of conjugate stresses.

For convenience of notation in discussing plane stress let us denote *compression* by the sign +, and *tension* by the sign -.

Let us also call that state of stress which is defined by equal principal stresses of the same sign a *fluid stress*. A material fluid can actually sustain only a + fluid stress, but it is convenient to include both compression and tension under one head as fluid stress, the properties of which we shall soon discuss.

Let us call a state of stress which is defined by unequal principal stresses of the same sign an *oblique stress*. This may be taken to include fluid stress as the particular case in which the inequality is infinitesimal. In this state of stress there is no plane on which the stress is a shear only, and the normal component of the stress on any plane whatever has the same sign as that of the principal stresses.

Furthermore let us call that state

of stress which is defined by a pair of shearing stresses of equal intensity and different sign on two planes at right angles to each other a *right shearing stress*. We shall have occasion immediately to discuss the properties of this kind of stress, but we may advantageously notice one of its properties in this connection. It has been seen previously from considerations of symmetry that the principal stresses and planes which may be used to define this state of stress, bisect the angles between the planes of equal shear. Hence in right shearing stress the principal stresses make angles of 45° with the planes of equal shear. We can advance one step further by considering the symmetrical position of the planes of equal shear with respect to the principal stresses and show that the principal stresses in a state of right shearing stress are equal but of opposite sign.

We wish to call particular attention to fluid stress and to right shearing stress, as with them our subsequent discussions are to be chiefly concerned: they are the special cases in which the principal stresses are of equal intensities, in one case of the same sign, in the other case of different sign.

Let us call a state of stress which is defined by a pair of equal shearing stresses of opposite sign on planes not at right angles an *oblique shearing stress*. The principal stresses, which in this case are of unequal intensity and bisect the angles between the planes of equal shear, are of opposite sign. A right shearing stress may be taken as the particular case of oblique shearing in which the obliquity is infinitesimal.

We may denote a state of stress as + or - according to the sign of its larger principal stress.

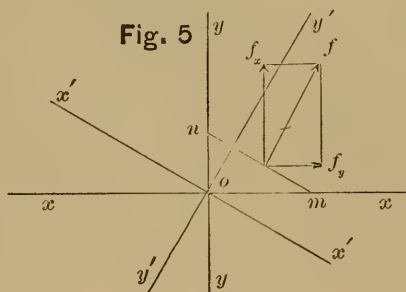

FLUID STRESS.—In Fig. 5 let xx and

yy two planes at right angles, on which the stress at o is normal, of equal intensity and of the same sign; then the stress on any plane, as $x'x'$, traversing o is normal, of the same intensity and same sign as that on xx or yy .

For consider a prism a unit long and of infinitesimal cross section having the face $mn \parallel x'x'$, then the forces f_x and f_y acting on the faces om and on are such that

$$f_x : f_y :: om : on.$$

Now $nm = \sqrt{om^2 + on^2}$, and the resultant force which the prism exerts against nm is

$$f = \sqrt{f_x^2 + f_y^2}, \quad \therefore f_x : f :: om : mn.$$

But $f_x \div om$ is the intensity of the stress on xx and $f \div mn$ is the intensity of the stress on $x'x'$, and these are equal. Also by similarity of triangles the resultant f is perpendicular to mn .

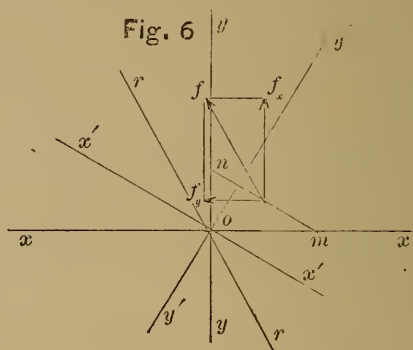

RIGHT SHEARING STRESS.—In Fig. 6, let xx and yy be two planes at right angles to each other, on which the stress is normal, of equal intensity, but of opposite sign; then the stress on any plane, as $x'x'$, traversing o is of the same intensity as that on xx and yy , but its obliquity is such that xx and yy respectively, bisect the angles between the direction rr of the resultant stress, and the normal $y'y'$ to its plane of action.

For, if the intensity of the stress on $x'x'$ be computed in the same manner as in Fig. 5, the intensity is found to be the same as that on xx or yy ; for the stresses to be combined are at right angles and are both of the same magnitude. The only difference between this case and that in Fig. 5 is this, that one of the

component stresses, that one normal to yy say, has its sign the opposite of that in Fig. 5. In Fig. 5 the stress on $x'x'$ was in the direction $y'y'$, making a certain angle yoy' with yy . In Fig. 6 the resultant stress on $x'x'$ must then make an equal negative angle with yy , so that $yoy = yoy'$. Hence the statement which has been made respecting right shearing stress is seen to be thus established.

COMBINATION AND SEPARATION.—Any states of stress which coexist at the same point and have their principal stresses in the same directions xx and yy combine to form a single state of stress whose principal stresses are the sums of the respective principal stresses lying in the same directions xx and yy : and conversely any state of stress can be separated into several coexistent stresses by separating each of its two principal stresses into the same number of parts in any manner, and then grouping these parts as pairs of principal stresses in any manner whatever.

The truth of this statement is necessarily involved in the fact that stresses are forces distributed over areas, and that as a state of stress is only the grouping together of two necessarily related stresses, they must then necessarily follow the laws of the composition and resolution of forces.

For the sake of brevity, we shall use the following nomenclature of which the meaning will appear without further explanation.

The terms applied to forces and stresses are:	The terms applied to states of stress are:
<i>Compound,</i>	<i>Combine,</i>
<i>Composition,</i>	<i>Combination,</i>
<i>Component,</i>	<i>Component state,</i>
<i>Resolve,</i>	<i>Separate,</i>
<i>Resolution,</i>	<i>Separation,</i>
<i>Resultant.</i>	<i>Resultant state.</i>

Other states of stress can be combined besides those whose principal stresses coincide in direction, but the law of combination is less simple than that of the composition of forces; such combinations will be treated subsequently.

COMPONENT STRESSES.—Any possible state of stress defined by principal stresses whose intensities are p_x and p_y on the planes xx and yy respectively is equivalent to a combination of the fluid stress whose intensity is $+\frac{1}{2}(p_x + p_y)$ on each of the planes xx and yy respectively, and the right shearing stress whose intensity is $+\frac{1}{2}(p_x - p_y)$ on xx and $-\frac{1}{2}(p_x - p_y)$ on yy .

For as has been shown, the resultant stress due to combining the fluid stress with the right shearing stress is found by compounding their principal stresses. Now the stress on xx is

$$\frac{1}{2}(p_x + p_y) + \frac{1}{2}(p_x - p_y) = p_x$$

and that on yy is

$$\frac{1}{2}(p_x + p_y) - \frac{1}{2}(p_x - p_y) = p_y$$

and hence these systems of principal stresses are mutually equivalent

In case $p_y = 0$, the stress is completely defined by the single principal stress p_x , which is a simple normal compression or tension on xx . Such a stress has been called a *simple stress*.

A fluid stress and a right shearing stress which have equal intensities combine to form a simple stress.

It is seen that the definition of a state of stress by its principal stresses, is a definition of it as a combination of two simple stresses which are perpendicular to each other.

There are many other ways in which any state of stress can be separated into component stresses, though the separation into a fluid stress and a right shearing stress has thus far proved more useful than any other, hence most of our graphical treatment will depend upon it. It may be noticed as an instance of a different separation, that it was shown that the tangential components of the stresses on any pair of planes xx and yy at right angles to each other are of equal intensity but opposite sign. These tangential components, then, together form a right shearing stress whose principal planes and stresses $x'x'$ and $y'y'$ bisect the angles between xx and yy , while the normal components together define a state of stress whose principal stresses are, in general, of unequal intensity.

Hence any state of stress can be separated into component stresses one of which is a right shearing stress on any two planes at right angles and a stress having those planes for its principal planes.

The fact of the existence of conjugate stresses points to still another kind of separation into component stresses.

PROBLEMS IN PLANE STRESS.

PROBLEM 1.—When a state of stress is defined by principal stresses which are of unequal intensity and like sign, *i.e.*, in a state of oblique stress, to find the intensity and obliquity of the stress at *o* on any assumed plane in the direction *uv*.

FIG. 7.

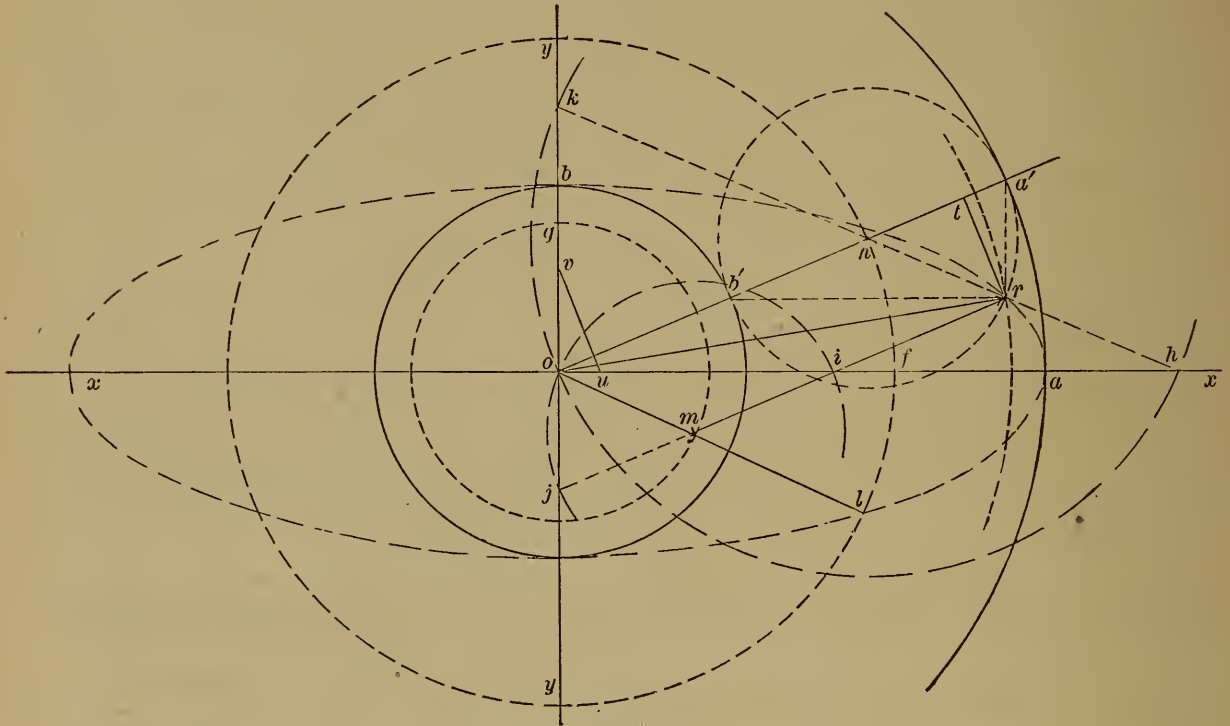

In Fig. 7 let the principal stresses at *o* be *a* on *yy* and *b* on *xx*; and on some convenient scale of intensities let *oa*=*a* and *ob*=*b*. Let *uv* show the direction of the plane through *o* on which we are to find the stress, and make *on* perpendicular *uv*. Make *oa'*=*oa* and *ob'*=*ob*. Bisect *a'b'* at *n*, then *on*= $\frac{1}{2}(a+b)$ and *na'*= $\frac{1}{2}(a-b)$. Make *xol*=*xon* and complete the parallelogram *nomr*; then is the diagonal *or*=*r* the resultant stress on the given plane in direction and intensity.

The point *r* can also be obtained more simply by drawing *b'r* || *xx* and *a'r* || *yy*.

We now proceed to show the correctness of the constructions given and to discuss several interesting geometrical properties of the figure which give to it a somewhat complicated appearance, which complexity is, however, quite unnecessary in actual construction, as will be seen hereafter. It has been shown

that a state of stress defined by its two principal stresses *a* and *b* can be separated into a fluid stress having a normal intensity $\frac{1}{2}(a+b)$ on every plane, and a right shearing stress whose principal stresses are $+\frac{1}{2}(a-b)$ and $-\frac{1}{2}(a-b)$ respectively.

Since the fluid stress causes a normal stress on any given plane, its intensity is rightly represented by *on*= $\frac{1}{2}(a+b)$, which is the amount of force distributed over one unit of the given plane. Since, further, it was shown that a right shearing stress causes on any plane a stress with an obliquity such that the principal stress bisects the angle between its direction and the normal to the plane, and causes a stress of the same intensity on every plane, we see that *om*= $\frac{1}{2}(a-b)$ represents, in direction and amount, the force distributed over one unit of the given plane which is due to the right shearing stress.

To find the resultant stress we have only to compound the forces on and om , which give the resultant $or=r$.

The obliquity nor is always toward the greater principal stress, which is here assumed to be a .

It is seen that in finding r by this method it is convenient to describe one circle about o with a radius $of=\frac{1}{2}(a+b)$ and another with a radius $og=-\frac{1}{2}(a-b)$, after which any parallelogram mn can be readily completed. Let nr and mr intersect xx and yy in hk and ij respectively; then we have the equations of angles,

$$noh=nho=\frac{1}{2}kno, nok=nko=\frac{1}{2}hno,$$

$$moi=mio=\frac{1}{2}jmo, moj=mjo=\frac{1}{2}imo,$$

hence $hn=kn=on=\frac{1}{2}(a+b)$

$$\therefore hk=a+b,$$

and $rk=rj=a, rh=ri=b$.

It is well known that a fixed point r on a line of constant length as $hk=a+b$, or $ij=a-b$ describes an ellipse, and such an arrangement is called a trammel. If x and y are the coordinates of the point r , it is evident from the figure that $x=a \cos \alpha n$, $y=b \sin \alpha n$, in which αn signifies the angle between xx and the normal on .

$\therefore \frac{x^2}{a^2} + \frac{y^2}{b^2} = 1$ is the equation of the stress

ellipse which is the locus of r ; and αn is then the eccentric angle of r . Also, since $noh=nho$, $nb'r=nr b'$; hence $b'r \parallel xx$ and $a'r \parallel yy$ determine r .

In this method of finding r it is convenient to describe circles about o with radii a and b , and from a' and b' where the normal of the given plane intersects them find r .

We shall continue to use the notation employed in this problem, so far as applicable, so that future constructions may be readily compared with this. It will be convenient to speak of the angle αn as αn , nor as nr , etc.

PROBLEM 2.—When a state of stress is defined by principal stresses of unequal intensity and unlike sign, *i.e.* in a state of oblique shearing stress, to find the intensity and obliquity of the stress at o on any assumed plane having the direction uv .

In Fig. 8 the construction is effected according to both the methods detailed in Problem 1, and it will be at once apprehended from the identity of notation.

Since a and b are of unlike signs $a+b=on$ is numerically less than $a-b=a'b'$.

The results of these two problems are expressed algebraically thus:

$$r^2 = \frac{1}{4}(a+b)^2 + \frac{1}{4}(a-b)^2 + \frac{1}{2}(a^2-b^2)\cos 2\alpha n$$

$$\therefore r^2 = \frac{1}{2}[a^2 + b^2 + (a^2 - b^2)\cos 2\alpha n]$$

$$\text{or, } r^2 = a^2 \cos^2 \alpha n + b^2 \sin^2 \alpha n.$$

FIG. 8.

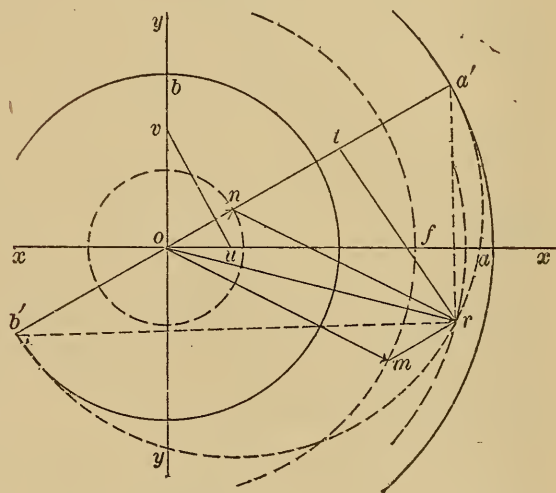

If r be resolved into its normal and tangential components $ot=n$ and $rt=t$

$$\text{then, } n = \frac{1}{2}[a+b+(a-b)\cos 2\alpha n],$$

$$\text{or, } n = a \cos^2 \alpha n + b \sin^2 \alpha n,$$

and,

$$t = \frac{1}{2}(a-b)\sin 2\alpha n = (a-b)\sin \alpha n \cos \alpha n.$$

It is evident from the value of the normal component n , that the sum of the normal components on any two planes at right angles to each other is the same and its amount is $a+b$: this is also a general property of stress in addition to those previously enumerated.

$$\text{Also } \tan nr = \frac{t}{n} = \frac{a-b}{a \cot \alpha n + b \tan \alpha n}$$

The obliquity nr can also be found from the proportion

$$\sin nr : \frac{1}{2}(a-b) :: \sin 2\alpha n : r.$$

In the case of fluid stress the equations reduce to the more simple forms:

$$a=b=r=n, t=0$$

For right shearing stress they are:

$$a=-b=\pm r, n=\pm a \cos rn,$$

$$t=\pm a \sin rn, rn=2 \alpha n.$$

And for simple stress they become:

$$b=0, r=a \cos rn, n=a \cos^2 rn, \\ t=a \sin rn \cos rn, rn=zn.$$

PROBLEM 3.—In any state of stress defined by its principal stresses, a and b , to find the obliquity and plane of action of the stress having a given intensity r intermediate between the intensities of the principal stresses.

To find the obliquity nr and the direction uv let Fig. 7 or 8 be constructed as follows: assume the direction uv and its normal on , and proceed to determine the position of the principal axes with respect to it. Lay off $oa'=a, ob'=b$, in the same direction if the intensities are of like sign, in opposite directions if unlike. Bisect $a'b'$ at n , and on $a'b'$ as a diameter draw the circle $a'rb'$. Also, about o as a center and with a radius $or=r$ draw a circle intersecting that previously drawn at r ; then is nr the required obliquity; and $xx' \parallel b'r, yy' \parallel a'r$ are the directions of the principal stresses with respect to the normal on .

PROBLEM 4.—In a state of stress defined by two given obliquities and intensities, to find the principal stresses, and the relative position of their planes of action to each other and to the principal stresses.

FIG. 9.

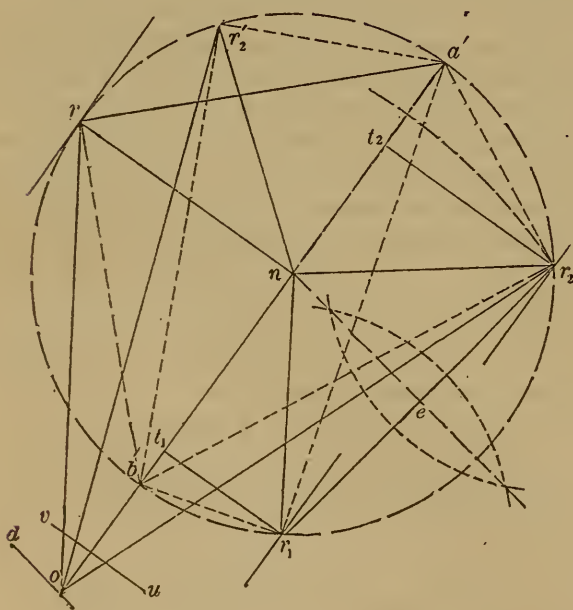

In Fig. 9 let nr_1, nr_2 be the given obliquities measured from the same nor-

mal on , and $or_1=r_1, or_2=r_2$ the given intensities. As represented in the figure these intensities are of the same sign, but should they have different signs, it will be necessary to measure one of them from o in the opposite direction, for a change of sign is equivalent to increasing the obliquity by 180° , as was previously shown.

Join r_1r_2 and bisect it by a perpendicular which intersects the common normal at n . About n describe a circle $r_1r_2a'b'$; then $oa'=a, ob'=b, a'r_1, b'r_1$, are the directions of the principal stresses with respect to r_1 and $b'r_2, a'r_2$ with respect to r_2 , i.e., $ob'r_1=zn_1$ and $ob'r_2=zn_2$

$$\therefore n_1n_2=ob'r_2-ob'r_1=r_2b'r_1=r_2a'r_1$$

In case the given obliquities are of opposite sign, as they must be in conjugate stresses, for example, it is of no consequence, in so far as obtaining principal stresses a and b is concerned, whether these given obliquities are constructed on the same side of on , or on opposite sides of it; for a point on the opposite side of on , as r_2' , and symmetrically situated with respect to r_2 , must lie on the same circle about n . But in case opposite obliquities are on the same side of on we have $n_1n_2=ob'r_1+ob'r_2=r_1b'r_2'$.

It is unnecessary to enter into the proof of the preceding construction as its correctness is sufficiently evident from preceding problems.

The algebraic relationships may be written as follows:

$$\frac{1}{4}(a-b)^2 = \frac{1}{4}(a+b)^2 + r_1^2 - r_1(a+b)\cos n_1r_1 \\ \frac{1}{4}(a-b)^2 = \frac{1}{4}(a+b)^2 + r_2^2 - r_2(a+b)\cos n_2r_2 \\ \therefore (a+b)(r_1\cos n_1r_1 - r_2\cos n_2r_2) = r_1^2 - r_2^2 \\ \text{Also } (a-b)\cos 2zn_1 + a + b = 2r_1\cos n_1r_1 \\ (a-b)\cos 2zn_2 + a + b = 2r_2\cos n_2r_2$$

which last equations express twice the respective normal components, and from them the values of zn_1 and zn_2 can be computed.

PROBLEM 5.—If the state of stress be defined by giving the intensity and obliquity of the stress on one plane, and its inclination to the principal stresses, and also the intensity of the stress on a second plane and its inclination to the principal stresses, to find the obliquity of

the stress on the second plane, and the magnitude of the principal stresses.

Let the construction in Fig. 9 be effected thus: from the common normal on lay off or_1 to represent the obliquity and intensity of the stress on the first plane; draw od so that $nod = xn_2 - xn_1$, the difference of the given inclinations of the normals of the two planes; through r_1 draw r_1r_2 perpendicular to od ; about o as a center describe a circle with radius r_2 the given intensity on the second plane, and let it intersect r_1r_2 at r_2 or r_2' , then is nr_2 the required obliquity. This is evident, because

$$\begin{aligned} xn_1 &= nb'r_1 = \frac{1}{2}a'nr_1, \quad xn_2 = nb'r_2 = \frac{1}{2}a'nr_2, \\ \therefore nod &= one = \frac{1}{2}(onr_1 + onr_2) \\ &= 180^\circ - (xn_2 - xn_1) \end{aligned}$$

If xn_1 and xn_2 are of different sign care must be taken to take their algebraic sum.

The construction is completed as in Problem 4.

PROBLEM 6.—In a state of stress defined by two given obliquities and either both of the normal components or both of the tangential components of the intensities, to find the principal stresses and the relative position of the two planes of action.

If in Fig. 9 the obliquities nr_1 , nr_2 , and the normal components $ot_1 = n_1$, $ot_2 = n_2$ are given, draw perpendiculars at t_1 and t_2 intersecting or_1 and or_2 at r_1 and r_2 respectively.

If the tangential components $t_1r_1 = t_1$ and $t_2r_2 = t_2$ are given instead of the normal components, draw at these distances parallels to on which intersect or_1 , or_2 at r_1 , r_2 respectively. Complete the construction in the same manner as before.

PROBLEM 7.—In a state of stress defined by its principal stresses a and b , to find the positions and obliquities of the stresses on two planes at right angles to each other whose stresses have a given tangential component t .

Fig. 9, slightly changed, will admit of the required construction as follows: lay off on the same normal on , $oa' = a$, $ob' = b$; bisect $a'b'$ at n ; erect a perpendicular $ne = t$ to $a'b'$ at n ; draw through e a parallel r_1r_2 to on intersecting or_1 and

or_2 at r_1 and r_2 respectively. Then the stresses $or_1 = r_1$, $or_2 = r_2$ have equal tangential components, and as previously shown these belong to planes at right angles to each other provided these tangential components are of opposite sign. So that when we find the position of the planes of action, one obliquity, as nr_2 , must be taken on the other side of on , as nr_2' . The rest of the construction is the same as that already given.

PROBLEM 8.—In a state of stress defined by its principal stresses, to find the intensities, obliquities and planes of action of the stresses which have maximum tangential components.

In Fig. 9 make $oa' = a$, $ob' = b$ and describe a circle on $a'b'$ as a diameter; then the maximum tangential component is evidently found by drawing a tangent at r parallel to on , in which case $t = a - b$, and rb' , ra' the directions of the principal stresses make angles of 45° with on , which may be otherwise stated by saying that the planes of maximum tangential stress bisect the angles between the principal stresses; or conversely the principal stresses bisect the angles between the pair of planes at right angles to each other on which the tangential stress is a maximum.

It is unnecessary to extend further the list of problems involving the relations just employed as they will be readily solved by the reader.

In particular, a given tangential and normal component may replace a given intensity and obliquity on any plane.

We shall now give a few problems which exhibit specially the distinction between states of stress defined by principal stresses of like sign and by principal stresses of unlike sign, (*i.e.* the distinction between oblique stress and oblique shearing stress).

PROBLEM 9.—In a state of stress defined by like principal stresses, to find the inclination of the planes on which the obliquity of the stress is a maximum, to find this maximum obliquity and the intensity.

In Fig. 10 let $oa' = a$, $ob' = b$, the principal stresses; on $a'b'$ as a diameter describe a circle; to it draw the tangent or_0 ; then nr_0 is the required maximum

obliquity and or_0 the required intensity. It is evident from inspection that in the given state of stress there can be no greater obliquity than nr_0 . The directions of the principal axes are $b'r_0, a'r_0$, as has been before shown.

There are two planes of maximum obliquity, and or'_0 represents the second; they are situated symmetrically about the principal axes.

Bisect nr_0 by the line od , then

$$\begin{aligned} oa'r_0 &= yn \therefore onr_0 = 2yn, \text{ but} \\ onr_0 + nor_0 &= 90^\circ \text{ or, } 2yn + nr_0 = 90^\circ \\ \therefore \frac{1}{2}nr_0 + yn &= 45^\circ, \text{ but} \\ odr_0 &= doa' + oa'd \therefore odr_0 = 45^\circ, \end{aligned}$$

hence the line bisecting the angle of maximum obliquity bisects also the angle between the principal axes. This is the best test for the correctness of the final position of the planes of maximum obliquity with reference to the principal axes.

FIG. 10.

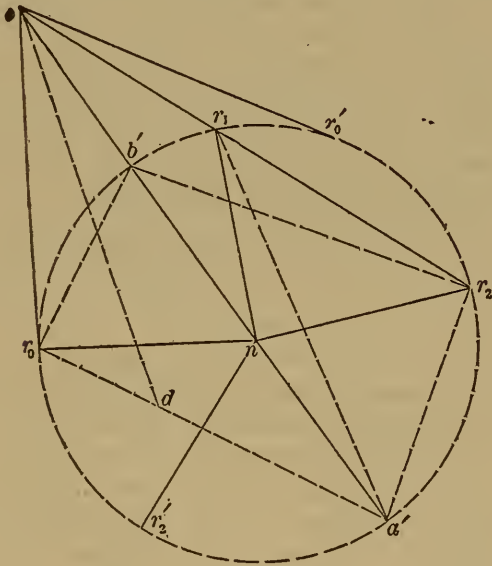

PROBLEM 10.—In a state of stress defined by its maximum obliquity and the intensity at that obliquity, to find the principal stresses.

In Fig. 10 measure the obliquity nr_0 from the normal on and at the extremity of $or_0=r_0$ erect a perpendicular intersecting the normal at n . Then complete the figure as before. The principal axes make angles of 45° at o with od which bisects the obliquity nr_0 .

The algebraic statement of Problems 9 and 10 is:

$$\sin nr_0 = \frac{a-b}{a+b} = -\cos 2xn, r_0^2 = ab.$$

$$r_0 = a \cot xn = b \tan xn, \therefore a = b \tan^2 xn$$

The normal and tangential components are:

$$n_0 = \frac{2r_0^2}{a+b}, \quad t_0 = \frac{r_0(a-b)}{a+b}.$$

PROBLEM 11.—When the state of stress is defined by like principal stresses, to find the planes of action and intensities of a pair of conjugate stresses having a given common obliquity less than the maximum.

In Fig. 10 let $nr_1=nr_2$ be the given obliquity; describe a circle on $a'b'$ as a diameter; then $or_1=r_1, or_2=r_2$ are the required intensities. The lines $a'r_1, b'r_1$ show the directions of the principal axes with respect to or_1 , and $a'r'_2, b'r'_2$ with respect to $or'_2=or_2$. The obliquities of conjugate stresses are of opposite sign, and for that reason r'_2 is employed for finding the position of the principal stresses. The algebraic expression of these results can be obtained at once from those in Problem 4.

PROBLEM 12.—When the state of stress is defined by the intensities and common obliquity of a pair of like conjugate stresses, to find the principal stresses and maximum obliquity.

This is the case of Problem 4, so far as finding the principal stresses is concerned, and the maximum obliquity is then found by Problem 9. The construction is given in Fig. 10.

PROBLEM 13.—Let the maximum obliquity of a state of oblique stress be given, to find the ratio of the intensities of the pair of conjugate stresses having a given obliquity less than the maximum.

In Fig. 10 let nr_0 be the given maximum obliquity, and nr_1 the given obliquity of the conjugate stresses. At any convenient point on or_0 , as r_0 erect the perpendicular r_0n , and about n (its point of intersection with on) as a center describe a circle with a radius nr_0 which

cuts nr_1 at r_1 and r_2 ; then $or \div or_2 = r_1 \div r_2$ is the required ratio.

It must be noticed that the scale on which or_1 and or_2 are measured is unknown, for the magnitude of the principal stresses is unknown although their ratio is $ob' \div oa'$. In order to express these results in formulæ, let r represent either of the conjugate stresses, then as previously seen

$$\frac{1}{2}(a-b)^2 = \frac{1}{2}(a+b)^2 + r^2 - r(a+b) \cos nr$$

$$\therefore 2r = (a+b) \cos nr \pm [(a+b)^2 \cos^2 nr - 4ab]^{\frac{1}{2}}$$

Call the two values of r , r_1 and r_2 ; and as previously shown $r_0^2 = r_1 r_2$; also

$$\cos nr_0 = r_0 \div \frac{1}{2}(a+b)$$

$$\therefore \frac{r_1}{r_2} = \frac{\cos nr - (\cos^2 nr - \cos^2 nr_0)^{\frac{1}{2}}}{\cos nr + (\cos^2 nr - \cos^2 nr_0)^{\frac{1}{2}}}$$

When $nr=0$ the ratio becomes

$$\frac{b}{a} = \frac{1 - \sin nr_0}{1 + \sin nr_0}$$

PROBLEM 14.—In a state of stress defined by unlike principal stresses, to find the inclination of the planes on which the stress is a shear only, and to find its intensity.

In Fig. 11 let $oa' = a$, $ob' = b$, the given principal stresses of unlike sign; on $a'b'$ as a diameter describe a circle; at o erect the perpendicular or_0 cutting the circle at r_0 ; then is $or_0 = r_0$ the required intensity, and $b'r_0$, $a'r_0$ are the directions of the principal stresses.

It is evident from inspection that there is no other position of r_0 except r_0' which will cause the stress to reduce to a shear alone. Hence as previously stated the principal stresses bisect the angles between the planes of shear.

PROBLEM 15.—In a state of stress defined by the position of its planes of shear and the common intensity of the stress on these planes, to find the principal stresses.

In Fig. 11 let $or_0 = r_0$, the common intensity of the shear, and $or_0 b' = xn$, $or_0 a' = yn$ the given inclinations of a plane of shear; then $oa' = a$ and $ob' = b$, the principal stresses.

The algebraic statement of Problems

14 and 15, when n_0 denotes the normal to a plane of shear, is:

FIG. 11.

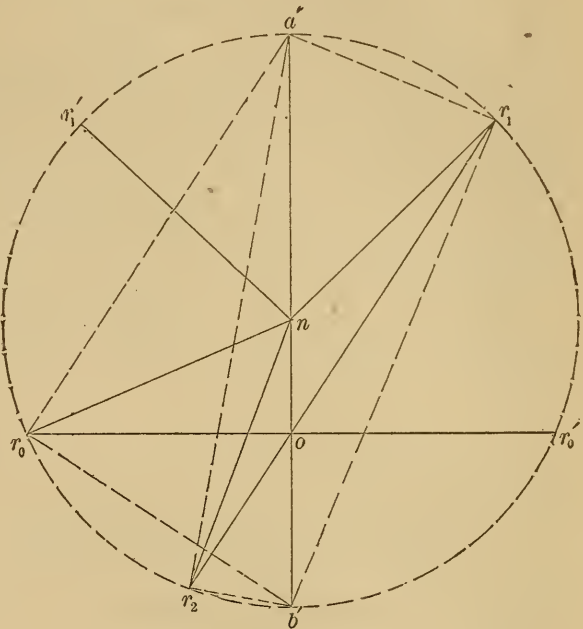

$$\frac{a+b}{a-b} = -\cos 2xn_0, \quad r_0^2 = -ab = t_0^2$$

$$r_0 = \pm a \cot xn_0 = \pm b \tan xn_0, a = -b \tan^2 xn_0$$

PROBLEM 16.—When the state of stress is defined by unlike principal stresses, to find the planes of action and intensities of a pair of conjugate stresses having any given obliquity.

In Fig. 11 let nr_1 be the common obliquity, $oa' = a$, $ob' = b$, the given principal stresses. On $a'b'$, as a diameter, describe a circle cutting or_1 at r_1 and r_2 ; then $or_1 = r_1$, $or_2 = r_2$ are the required intensities. Also, since the obliquities of conjugate stresses are of unlike sign, the lines $r_1'a'$, $r_1'b'$ show the directions of the principal stresses with respect to on_1 , and $r_2'a'$, $r_2'b'$ with respect to on_2 .

PROBLEM 17.—When the state of stress is defined by the intensities and common obliquities of unlike conjugate stresses, to find the principal stresses and planes of shear.

In finding the principal stresses this problem is constructed as a case of Problem 4, and then the planes of shear are found by Problem 14. The construction is given in Fig. 11.

PROBLEM 18.—Let the position of the

planes of shear be given in a state of oblique shearing stress, to find the ratio of the intensities of a pair of conjugate stresses having any given obliquity.

In Fig. 11 at any convenient point r_o make $or_o b' = xn$, $or_o a' = yn$, the given angles which fix the position of the planes of shear. On $a'b'$ as a diameter describe a circle; make nr_1 equal to the common obliquity of the conjugate stresses; then is $or_1 \div or_2 = r_1 \div r_2$ the ratio required.

The ratio may be expressed as in Problem 13, and after reducing by the relations

$$r_o^2 = -ab, \quad r_o \div \frac{1}{2}(a+b) = \tan 2\alpha n_o,$$

we have,

$$\frac{r_1}{r_2} = \frac{\cos nr + (\cos^2 nr + \tan^2 2\alpha n_o)^{\frac{1}{2}}}{\cos nr - (\cos^2 nr + \tan^2 2\alpha n_o)^{\frac{1}{2}}}$$

When $nr=0$ the ratio becomes

$$\frac{a}{b} = \frac{1 + \cos 2\alpha n_o}{1 - \cos 2\alpha n_o}$$

COMBINATION AND SEPARATION OF STATES OF STRESS.

PROBLEM 19.—When two given states of right shearing stress act at the same point, and their principal stresses have a given inclination to each other, to combine these states of stress and find the resultant state.

In Fig. 12 let ox_1, ox_2 denote the directions of the two given principal + stresses, and let $a_1 = on_1, a_2 = on_2$ repre-

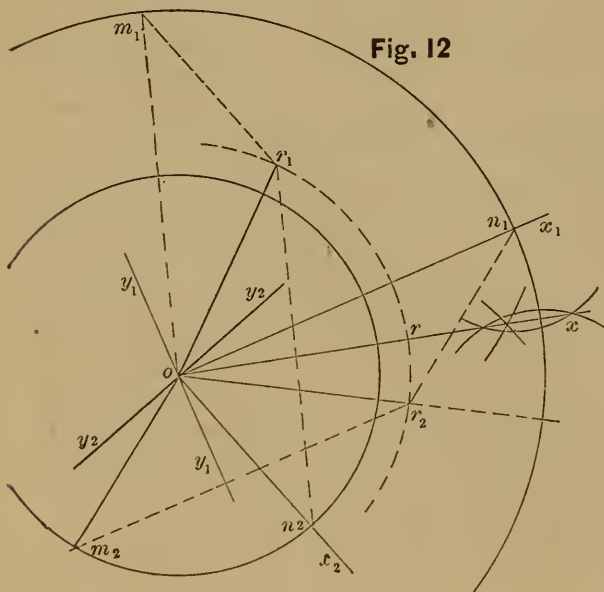

Fig. 12

sent the position and magnitude of these principal stresses. Since the given stresses are right shearing stresses $a_1 = -b_1, a_2 = -b_2$ and the respective planes of shear bisect the angles between the principal stresses. Now it has been previously shown that the intensity of the stress caused by the principal stresses $a_1 = -b_1$ is the same on every plane traversing o : the same is true of the principal stresses $a_2 = -b_2$: hence, when combined, they together produce a stress of the same intensity on every plane traversing o . This resultant state of stress evidently does not cause a normal stress on every plane, hence the resultant state must be a right shearing stress.

Let us find its intensity as follows: The principal stresses $a_1 = -b_1$ cause a stress on_1 on the plane y_1y_1 , and the principal stresses $a_2 = -b_2$ cause a stress om_2 on the same plane in such a direction that $x_2om_2 = x_1ox_2$, as has been before shown. Complete the parallelogram $n_1om_2r_2$; then or_2 represents the intensity and direction of the stress on y_1y_1 . But the principal stresses bisect the angles between the normal and the resultant intensity, therefore, ox , which bisects x_1or_2 , is the direction of a principal stress of the resultant state, and $or = or_2 = a$ is the intensity of the resultant stress on any plane through o .

The same result is obtained by finding the stress the plane y_2y_2 , in which case we have $on_2 = a_2$ acting normal to the plane, and $om_1 = a_1$ in such a direction that $x_1om_1 = x_2ox_1$. The sides and angles of $n_2om_1r_1$ and $n_1om_2r_2$ are evidently equal, hence the resultants are the same, $or_1 = or_2 = a$, and ox bisects x_2or_1 .

The algebraic solution of the problem is expressed by the equation,

$$a^2 = a_1^2 + a_2^2 + 2a_1a_2 \cos 2x_1x_2,$$

from which a may be found, and, finally, the position of or is found from the proportion,

$$\sin 2\alpha x_1 : a_2 :: \sin 2\alpha x_2 : a_1 :: \sin 2x_1x_2 : a.$$

PROBLEM 20.—When any two states of stress, defined by their principal stresses, act at the same point, and their principal stresses have a given inclination to each other, to combine these states and find the resultant state.

Let a_1, b_1 , and a_2, b_2 be the given prin-

cipal stresses, of which a_1 and a_2 have the same sign and are inclined at a known angle x_1x_2 , but in so taking a_1 and a_2 they may not both be numerically greater than b_1 and b_2 respectively.

Separate the pair of principal stresses a_1, b_1 into the fluid stress $+\frac{1}{2}(a_1+b_1)$, and the right shearing stress $\pm\frac{1}{2}(a_1-b_1)$ as has been previously done; and in a similar manner the principal stresses a_2, b_2 into $+\frac{1}{2}(a_2+b_2)$ and $\pm\frac{1}{2}(a_2-b_2)$. Then the combined fluid stresses produce a fluid stress of $+\frac{1}{2}(a_1+b_1+a_2+b_2)$ on every plane through o ; and the combined right shearing stresses cause a stress whose intensity and position can be found by Problem 19.

The total stress is obtained by combining the total fluid stress with the resultant right shearing stress.

Of course, any greater number of states of stress than two, can be combined by this problem by combining the resultant of two states with a third state and so on.

The algebraic expression of the combination of any two states of stress is as follows :

$$(a+b) = (a_1+b_1+a_2+b_2),$$

$$(a-b)^2 = (a_1-b_1)^2 + (a_2-b_2)^2 + 2(a_1-b_1)(a_2-b_2) \cos 2x_1x_2,$$

$$\therefore a = \frac{1}{2}(a_1+b_1+a_2+b_2 + [(a_1-b_1)^2 + (a_2-b_2)^2 + 2(a_1-b_1)(a_2-b_2) \cos 2x_1x_2]^{1/2}),$$

$$b = \frac{1}{2}(a_1+b_1+a_2+b_2 - [(a_1-b_1)^2 + (a_2-b_2)^2 + 2(a_1-b_1)(a_2-b_2) \cos 2x_1x_2]^{1/2}),$$

in which a and b are the resultant principal stresses. Also, $\sin 2xx_1 : a_2 - b_2$

$$:: \sin 2xx_2 : a_1 - b_1 :: \sin 2x_1x_2 : a - b.$$

PROBLEM 21.—In a state of stress defined by the stresses upon two planes at right angles to each other, to find the principal stresses.

Let the given stresses be resolved into tangential and normal components; it has been shown that the tangential components upon these planes are of equal intensity and unlike sign. Let the intensity of the tangential component be a_t , and that of the normal components a_n and b_n respectively. The tangential components together constitute a state of right shearing stress of which the given planes are the planes of shear,

and the principal stresses bisect the angles between the given planes.

Separate the remaining state of stress into the fluid stress $+\frac{1}{2}(a_n+b_n)$ and the right shearing stress $\pm\frac{1}{2}(a_n-b_n)$, and combine this last right shearing stress with that due to the tangential components. The final result is found, just as in Problem 20, by combining the fluid stress $\frac{1}{2}(a_n+b_n)$ with the resulting right shearing stress.

This problem can also be solved in a manner similar to that employed in Problem 6.

The result is expressed by the equations,

$$a+b = a_n + b_n,$$

$$(a-b)^2 = (a_n - b_n)^2 + 4a_t^2$$

for the angle which has been heretofore denoted by x_1x_2 is in this case $45^\circ \therefore \cos 2x_1x_2 = 0$

$$\therefore a = \frac{1}{2}(a_n + b_n + [(a_n - b_n)^2 + 4a_t^2]^{1/2})$$

$$b = \frac{1}{2}(a_n + b_n - [(a_n - b_n)^2 + 4a_t^2]^{1/2})$$

$$\sin. 2xx_1 : 2a_t :: \sin. 2xx_2 : a_n - b_n \\ :: 1 : a - b,$$

but $2xx_1 = 90^\circ - 2xx_2$,

$$\therefore \tan 2xx_1 = 2a_t \div (a_n - b_n).$$

PROBLEM 22.—In a state of stress defined by two simple stresses which act at the same point and have a given inclination to each other, to combine them and find the resultant state.

It has been previously mentioned that any simple stress as a_1 can be separated into the fluid stress $+\frac{1}{2}a_1$ and the right shearing stress $\pm\frac{1}{2}a_1$, as it is simply a case in which $b_1 = 0$. Hence the simple stresses a_1, a_2 can be combined as a special case of Problem 20, in which b_1 and b_2 vanish. The results are expressed algebraically as follows:

$$a+b = a_1 + a_2,$$

$$(a-b)^2 = a_1^2 + a_2^2 + 2a_1a_2 \cos 2x_1x_2$$

$$\therefore ab = \frac{1}{2}a_1a_2(1 - \cos 2x_1x_2)$$

$$\therefore ab = a_1a_2 \sin^2 x_1x_2.$$

Since a simple compression or tension produces a simple stress in material, this problem is one of frequent occurrence, for it treats the superposition of two, and hence of any number of simple stresses lying in the same plane.

This problem is of such importance that we think it useful to call attention

to another solution of it, suggested by the algebraic expressions just found.

In Fig. 13 let

$$o'a' = a_1, o'b' = a_2 \therefore o'r' = \sqrt{a_1 a_2} = oi.$$

Now, if $oir = x_1 x_2$, then $or = o'r' \sin x_1 x_2$

$$\therefore \overline{or}^2 = oa' \cdot ob' = o'a' \cdot o'b' \sin^2 x_1 x_2$$

$$\therefore oa' = a \text{ and } ob' = b.$$

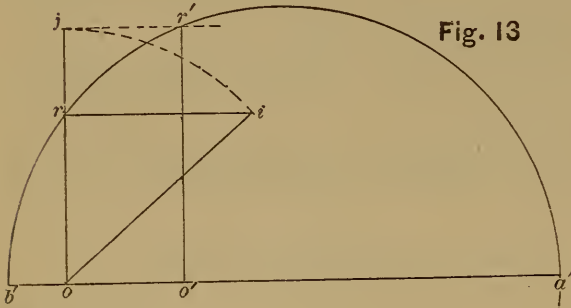

Fig. 13

This solution is treated more fully in Problem 23.

PROBLEM 23.—When a state of stress is defined by its principal stresses, it is required to separate it into two simple stresses having a given inclination to each other.

It was shown in Problem 22 that $a + b = a_1 + a_2$, and $ab = a_1 a_2 \sin x_1 x_2$.

Let us apply these equations in Fig. 13 to effect the required construction. Make $oa' = a$, $ob' = b$; then $a'b' = a_1 + a_2$. At o erect a perpendicular to $a'b'$ cutting the circle of which $a'b'$ is the diameter at r ; then $\overline{or}^2 = ab$, the product of the principal stresses. Also make $a'oi = x_1 x_2$ the given inclination of the simple stresses, and let $ri \parallel a'b'$ intersect oi at i ; then $or = oi \sin x_1 x_2 \therefore \overline{oi}^2 = a_1 a_2$.

Make $oj = oi$ and draw $jr' \parallel a'b'$, then

$$o'r' = oi, \text{ and } o'a' \cdot o'b' = \overline{or'}^2,$$

$$\therefore o'a' = a_1 \text{ and } o'b' = a_2,$$

the required simple stresses. This construction applies equally whether the given principal stresses are of like or unlike sign, and also equally whether the two simple stresses are required to have like or unlike signs.

PROBLEM 24.—When a state of stress is defined by its principal stresses, to find the inclination of two given simple stresses into which it can be separated.

In Fig. 13 let $oa' = a$, $ob' = b$ be the intensities of the principal stresses, and $o'a' = a_1$, $o'b' = a_2$ be the intensities of the given simple stresses. It has been already shown that $a + b = a_1 + a_2$. Draw the two perpendiculars or and $o'r'$; through r draw $ri \parallel a'b'$; make $oi = oj = o'r'$; then is $oir = ioa'$ the required inclination, for it is such that

$$ab = a_1 a_2 \sin^2 x_1 x_2$$

PROBLEM 25.—To separate a state of right shearing stress of given intensity into two component states of right shearing stress whose intensities are given, and to find the mutual inclination of the principal stresses of the component states.

In Fig. 12, about the center o , describe circles with radii $on_1 = a_1$, $on_2 = a_2$, the given component intensities; and also about o at a distance $or_1 = a$, the given intensity. Also describe circles with radii $r_1 m_1 = on_2$, $r_1 n_2 = on_1$ cutting the first mentioned circles at m_1 and n_2 ; then is $\frac{1}{2} n_2 om_1 = x_1 x_2$ the required mutual inclination of the principal stresses of the component states. This is evident from considerations previously adduced in connection with this figure. The relative position of the principal stresses and principal component stresses is also readily found from the figure.

PROBLEM 26.—In a state of right shearing stress of given intensity to separate it into two component states of right shearing stress, when the intensity of one of these components is given and also the mutual inclination of the principal stresses of the component states.

In Fig. 12, about the center o describe a circle rr with radius $or = a$, the intensity of the given right shearing stress, and at n_1 , at a distance $on_1 = a_1$ from o which is the intensity of the given component, make $x_1 n_1 r_2 = 2x_1 x_2$, twice the given mutual inclination; then is $n_1 r_2$ the distance from n_1 to the circle rr the intensity of the required component stress. The figure can be completed as was done previously.

It is evident, when the component a_1 exceed a , that there is a certain maximum value of the double inclination, which can be obtained by drawing $n_1 r_2$.

tangent to the circle rr , and the given inclination is subject to this restriction.

Other problems concerning the combination and separation of states of stress can be readily solved by methods like those already employed, for such problems can be made to depend on the combination and separation of the fluid stresses and right shearing stresses into which every state of stress can be separated.

PROPERTIES OF SOLID STRESS.

We shall call that state of stress at a point a *solid stress* which causes a stress on every plane traversing the point. In the foregoing discussion of plane stress no mention was made of a stress on the plane of the paper, to which the plane stress was assumed to be parallel. It is, evidently, possible to combine a simple stress perpendicular to the plane of the paper with any of the states of stress heretofore treated without changing the stress on any plane perpendicular to the paper.

Hence in treating plane stress we have already treated those cases of solid stress which are produced by a plane stress combined with any stress perpendicular to its plane, acting on planes also perpendicular to the plane of the paper.

We now wish to treat solid stress in a somewhat more general manner, but as most practical cases are included in plane stress, and the difficulties in the treatment of solid stress are much greater than those of plane stress, we shall make a much less extensive investigation of its properties.

CONJUGATE STRESSES.—Let xx , yy , zz be any three lines through o ; now, if any state of stress whatever exists at o , and xx be the direction of the stress on the plane yoz , and yy that on zox , then is zz the direction of the stress on xoy : *i.e.*, each of these three stresses lies in the intersection of the planes of action of the other two.

Reasoning like that employed in connection with Fig. 1, shows that no other direction than that stated could cause internal equilibrium; but a state of stress is a state of equilibrium, hence follows the truth of the above statement.]

TANGENTIAL COMPONENTS.—Let xx , yy , zz be rectangular axes through o ; then, whatever may be the state of stress at o , the tangential components along xx and yy are equal, as also are those along yy and zz , as well as those along zz and xx .

The truth of this statement flows at once from the proof given in connection with Fig. 3.

It should be noticed that the total shear on any plane xoy , for example, is the resultant of the two tangential components which are along xx and yy respectively.

STATE OF STRESS.—Any state of solid stress at o is completely defined, so that the intensity and direction of the stress on any plane traversing o can be completely determined, when the stresses on any three planes traversing o are given in magnitude and direction.

This truth appears by reasoning similar to that employed with Fig. 4, for the three given planes with the fourth enclose a tetrahedron, and the total distributed force acting against the fourth plane is in equilibrium with the resultant of the forces acting on the first three.

PRINCIPAL STRESSES.—In any state of solid stress there is one set of three conjugate stresses at right angles to each other, *i.e.* there are three planes at right angles on which the stresses are normal only.

Since the direction of the stress on any plane traversing a given point o can only change gradually, as the plane through o changes in direction, it is evident from the directions of the stresses on conjugate planes that there must be at least one plane through o on which the stress is normal to the plane. Take that plane as the plane of the paper; then, as proved in plane stresses, there are two more principal stresses lying in the plane of the paper, for the stress normal to the plane of the paper has no component on any plane also perpendicular to the paper.

FLUID STRESS.—Let the stresses on three rectangular planes through o be

normal stresses of equal intensity and like sign; then the stress on any plane through o is also normal of the same intensity and same sign.

This is seen to be true when we combine with the stresses already acting in Fig. 5, another stress of the same intensity normal to the plane of the paper.

RIGHT SHEARING STRESS.—Let the stresses on three rectangular planes through o be normal stresses of equal intensity, but one of them, say the one along xx , of sign unlike that of the other two; then the stress on any plane through o , whose normal is $x'x'$, is of the same intensity and lies in the plane xox' in such a direction rr that xx and the plane yz bisect the angles in the plane xox' between rr and its plane of action, and rox' respectively.

The stress parallel to yz is a plane fluid stress, and causes therefore a normal stress on the plane xox' . Hence the resultant stress is in the direction stated, as was proved in Fig. 6.

COMPONENT STATES OF STRESS.—Any state of solid stress, defined by its principal stresses abc along the rectangular axes of xyz respectively, is equivalent to the combination of three fluid stresses, as follows:

$$\begin{aligned} &\frac{1}{2}(a+b) \text{ along } x \text{ and } y, -\frac{1}{2}(a+b) \text{ along } z; \\ &\frac{1}{2}(c+a) \text{ along } z \text{ and } x, -\frac{1}{2}(c+a) \text{ along } y; \\ &\frac{1}{2}(b+c) \text{ along } y \text{ and } z, -\frac{1}{2}(b+c) \text{ along } x; \end{aligned}$$

For these together give rise to the following combination:

$$\begin{aligned} &\frac{1}{2}(a+b) + \frac{1}{2}(c+a) - \frac{1}{2}(b+c) = a, \text{ along } x; \\ &\frac{1}{2}(a+b) - \frac{1}{2}(c+a) + \frac{1}{2}(b+c) = b, \text{ along } y; \\ &\frac{1}{2}(a+b) + \frac{1}{2}(c+a) + \frac{1}{2}(b+c) = c, \text{ along } z. \end{aligned}$$

In case $b=0$ and $c=0$ this is a simple stress along x .

COMPONENT STRESSES.—Any state of solid stress defined by its principal stresses can also be separated into a fluid stress and three right shearing stresses, as follows:

$$\frac{1}{4}(a+b+c) \text{ along } x, y, z;$$

$$\begin{aligned} &\frac{1}{4}(a-b-c) \text{ along } x, \text{ and} \\ &\quad -\frac{1}{4}(a-b-c) \text{ along } y \text{ and } z; \\ &\frac{1}{4}(b-c-a) \text{ along } y, \text{ and} \\ &\quad -\frac{1}{4}(b-c-a) \text{ along } z \text{ and } x; \\ &\frac{1}{4}(c-a-b) \text{ along } z, \text{ and} \\ &\quad -\frac{1}{4}(c-a-b) \text{ along } x \text{ and } y; \end{aligned}$$

It will be seen that the total stresses along xyz are $a b c$ respectively. This system of component stresses is remarkable because it is strictly analagous in its geometric relationships to the trammel method used in plain stress. We shall simply state this relationship without proof, as we shall not use its properties in our construction.

If the distances $pa_1=a, pb_1=b, pc_1=c$ be laid off along a straight line from the point p , and then this straight be moved so that the points $a_1 b_1 c_1$ move respectively in the planes yz, zx, xy ; then p will describe an ellipsoid, as is well known, whose principal semiaxes are along xyz , and are abc respectively. Now the distances pa_1, pb_1, pc_1 , may be laid off in the same direction from p or in different directions; so that, in all, four different combinations can be made, either of which will describe the same ellipsoid. But the position of these four generating lines through any assumed point $x_1 y_1 z_1$ of the ellipsoid is such that their equations are

$$\frac{a}{x_1}(x-x_1) = \pm \frac{b}{y_1}(y-y_1) = \pm \frac{c}{z_1}(z-z_1)$$

Now if the fluid stress $\frac{1}{4}(a+b+c) = or_1$ be laid off along the normal to any plane, *i.e.* parallel to that generating line which in the above equation has all its signs positive, and the other three right shearing stresses $r_1 r_2, r_2 r_3, r_3 r_4$ be laid off successively parallel to the other generating lines, as was done in plane stresses, the line or_4 will be the resultant stress on the plane.

PROBLEMS IN SOLID STRESS.

PROBLEM 27.—In any state of stress defined by the stresses on three rectangular planes, to find the stress on any given plane.

Let the intensities of the normal components along xyz be $a_n b_n c_n$ respectively, and the intensities of the pairs of tangential components which lie in the planes which intersect in xyz and are

perpendicular to those axes be a_t b_t c_t respectively, e.g., a_t is the intensity of the tangential component on xoy along y , or its equal on xoz along z .

In Fig. 14 let a plane parallel to the given plane cut the axes at $x_1y_1z_1$; then the total forces on the area $x_1y_1z_1$ along xyz are respectively:

Fig. 14

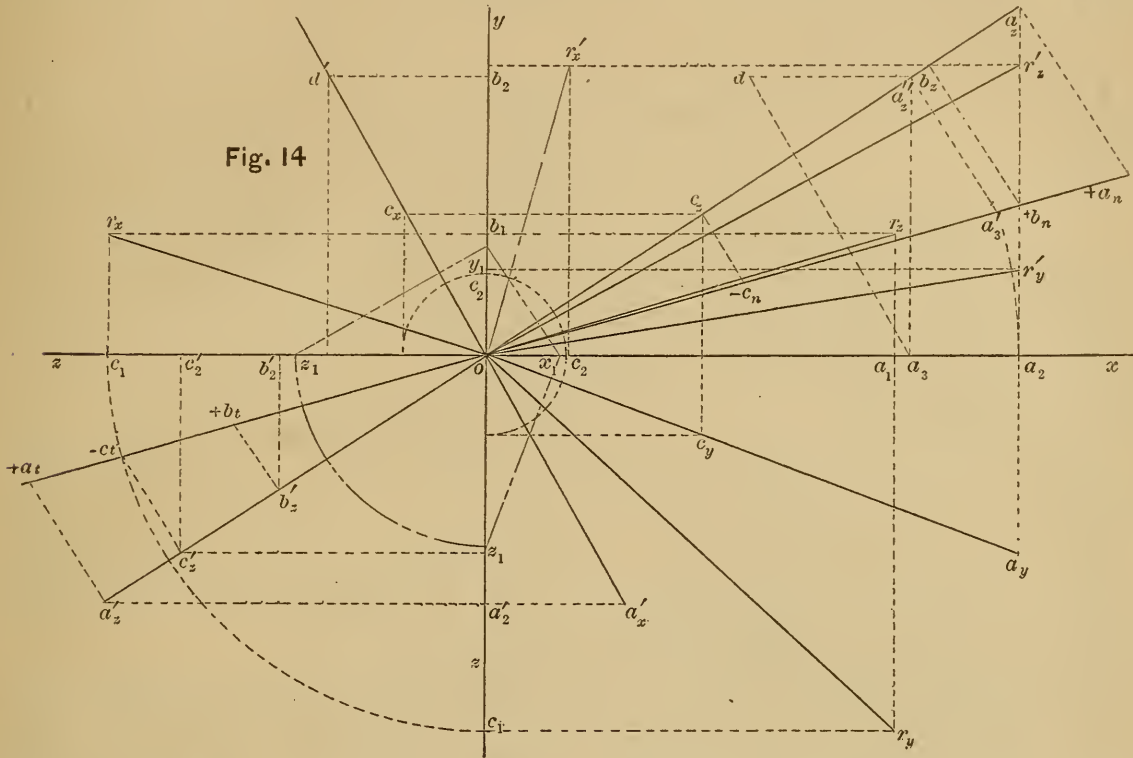

$\overline{x_1y_1z_1} \cdot a_1 = \overline{y_1oz_1} \cdot a_n + \overline{x_1oy_1} \cdot b_t + \overline{z_1ox_1} \cdot c_t$
 $\overline{x_1y_1z_1} \cdot b_1 = \overline{y_1oz_1} \cdot c_t + \overline{x_1oy_1} \cdot a_t + \overline{z_1ox_1} \cdot b_n$
 $\overline{x_1y_1z_1} \cdot c_1 = \overline{y_1oz_1} \cdot b_t + \overline{x_1oy_1} \cdot c_n + \overline{z_1ox_1} \cdot a_t$
 in which a_1, b_1, c_1 are the intensities of the components of the stress on the plane $x_1y_1z_1$ along xyz respectively. Now

$$\overline{y_1oz_1} \div \overline{x_1y_1z_1} = \cos xn$$

$$\overline{z_1ox_1} \div \overline{x_1y_1z_1} = \cos yn$$

$$\overline{x_1oy_1} \div \overline{x_1y_1z_1} = \cos zn.$$

$$\therefore a_1 = a_n \cos xn + b_t \cdot \cos zn + c_t \cos yn$$

$$b_1 = c_t \cos xn + a_t \cdot \cos zn + b_n \cos yn$$

$$c_1 = b_t \cos xn + c_n \cdot \cos zn + a_t \cos yn$$

and $r^2 = a_1^2 + b_1^2 + c_1^2$, therefore the resultant stress r is the diagonal of the right parallelepiped whose edges are a_1, b_1, c_1 . In order to construct a_1, b_1, c_1 it is only necessary to lay off $a_n, b_n, c_n, a_t, b_t, c_t$ along the normal, and take the sums of such projections along xyz as are indicated in the above values of a_1, b_1, c_1 .

Thus, in Fig. 14, let $x_1y_1z_1$ be the traces of a plane, and it is required to construct the stress upon a plane parallel to it through o .

The ground line between the planes of xoy and xoz is ox . The planes xoz and yoz on being revolved about ox and oy respectively, as in ordinary descriptive geometry, leave oz in two revolved positions at right angles to each other.

The three projections of the normal at o to the given plane are, as is well known, perpendicular to the traces of the given plane, and they are so represented. Let oa_z be the projection of the normal on xoy , and oa_y that on xoz . To find the true length of the normal, revolve it about one projection, say about oa_z , and if $a_z a_n = a_2 a_y$ then is oa_n the revolved position of the normal.

Upon the normal let $oa_n = a_n, ob_n = b_n, oc_n = c_n$, the given normal components of the stresses upon the rectangular planes, and also let $oa_t = a_t, ob_t = b_t, oc_t = c_t$, the given tangential components upon the same planes.

Let $a_2, b_2, c_2, a'_2, b'_2, c'_2$ be the respective projections of the points $a_n, b_n, c_n, a_t, b_t, c_t$ of the normal upon the plane xoy by lines parallel to oz , similarly $a_y, etc.$, are projections by parallels to oy , and $a_x', etc.$, by parallels to ox .

We have taken the stresses c_n and c_t of

different sign from the others, and so have called them negative and the others positive.

It is readily seen that the first of the above equations is constructed as follows:

$$a_1 = oa_1 = oa_2 + b_1 b_z' - c_z' c_2'$$

Similarly, the other two equations become:

$$b_1 = ob_1 = -oc_2' + a_1 a_2' + ob_2$$

$$c_1 = oc_1 = ab_2' - c_2 c_1 + oa_2'$$

We have thus found the coordinates of the extremity r of the stress or upon the given plane; hence its projections upon the planes of reference are respectively or_x, or_y, or_z .

PROBLEM 28.—In any state of stress defined by its three principal stresses, to find the stress on any given plane.

This problem is the special case of Problem 27, in which the tangential components are each zero. Taking the normal components given in Fig. 14 as principal stresses we find $oa_2 = a_n \cos xn$, $ob_2 = b_n \cos yn$, $oc_2 = c_n \cos zn$, as the coordinates which determine the stress or' upon the given plane, and the projections of or' are or_x', or_y', or_z' , respectively.

From these results it is easy to show that the sum of the normal components of the stresses on any three planes is constant and equal to the sum of the principal stresses. This is a general property of solid stress in addition to those previously stated.

PROBLEM 29.—Any state of stress being defined by given simple stresses, to find the stresses on three planes at right angles to each other.

In Fig. 14 let a simple stress act along the normal to the plane $x_1 y_1 z_1$, and cause

a stress on that plane whose intensity is $a_n = oa_n$, then is $a_n \cos xn = oa_2$, the intensity of the stress in the same direction acting on the plane yoz . The normal component of this latter intensity is

$$a_n \cos^2 xn = oa_2, \cos xn = oa_3,$$

and it is obtained by making $oa_3' = oa_2$, $a_3' a_z'' \parallel x_1 y_1$, and $a_z'' a_3'' \parallel oy$. The tangential component on yoz is od' in magnitude and direction, and it is obtained thus: make $a_z'' d = a_z'' a_3'$, then in the right angled triangle $da_3 a_2''$, da_3 is the magnitude of the tangential component; now make $od' = da_3$. This tangential component can be resolved along the axes of y and z . The stress on the planes zox and xoy can be found in similar manner, since the tangential components which act on two planes at right angles to each other and in a direction perpendicular to their intersection are, as has been shown, equal; the complete construction will itself afford a test of its accuracy.

Other simple stresses may be treated in the same manner, and the resultant stress on either of the three planes, due to these simple stresses, is found by combining together the components which act on that plane due to each of the simple stresses.

It is useless to make the complete combination. It is sufficient to take the algebraic sum of the normal components acting on the plane, and then the algebraic sum of the tangential components along two directions in the plane which are at right angles, as along y and z in yoz .

The treatment of conjugate stresses in general appears to be too complicated to be practically useful, and we shall not at present construct the problems arising in its treatment.

SCIENTIFIC BOOKS

PUBLISHED BY

D. VAN NOSTRAND,

23 Murray Street and 27 Warren Street,

NEW YORK.

Any Book in this Catalogue, sent free by mail on receipt of price.

Weisbach's Mechanics.

Fourth Edition, Revised. 8vo. Cloth. \$10.00.

A MANUAL OF THEORETICAL MECHANICS. By Julius Weisbach, Ph. D. Translated from the fourth augmented and improved German edition, with an introduction to the Calculus, by Eckley B. Coxe, A. M., Mining Engineer. 1100 pages and 902 wood-cut illustrations.

Francis' Lowell Hydraulics.

Third Edition. 4to. Cloth. \$15.00.

LOWELL HYDRAULIC EXPERIMENTS—being a Selection from Experiments on Hydraulic Motors, on the Flow of Water over Weirs, and in open Canals of Uniform Rectangular Section, made at Lowell, Mass. By J. B. Francis, Civil Engineer. Third edition, revised and enlarged, including many New Experiments on Gauging Water in Open Canals, and on the Flow through Submerged Orifices and Diverging Tubes. With 23 copperplates, beautifully engraved, and about 100 new pages of text.

Kirkwood on Filtration.

4to. Cloth. \$15.00.

REPORT ON THE FILTRATION OF RIVER WATERS, for the Supply of Cities, as practised in Europe, made to the Board of Water Commissioners of the City of St. Louis. By JAMES P. KIRKWOOD. Illustrated by 30 double-plate engravings.

Rogers' Geology of Pennsylvania.

3 Vols. 4to, with Portfolio of Maps. Cloth. \$30.00.

THE GEOLOGY OF PENNSYLVANIA. A Government Survey. With a general view of the Geology of the United States, Essays on the Coal Formation and its Fossils, and a description of the Coal Fields of North America and Great Britain. By HENRY DARWIN ROGERS, Late State Geologist of Pennsylvania. Splendidly illustrated with Plates and Engravings in the Text

Merrill's Iron Truss Bridges.

Third Edition. 4to. Cloth. \$5.00.

IRON TRUSS BRIDGES FOR RAILROADS. The Method of Calculating Strains in Trusses, with a careful comparison of the most prominent Trusses, in reference to economy in combination, etc., etc. By Bvt. Col. WILLIAM E. MERRILL, U.S.A., Corps of Engineers. Nine lithographed plates of illustrations.

Shreve on Bridges and Roofs.

8vo, 87 wood-cut illustrations. Cloth. \$5.00.

A TREATISE ON THE STRENGTH OF BRIDGES AND ROOFS—comprising the determination of Algebraic formulas for Strains in Horizontal, Inclined or Rafter, Triangular, Bowstring, Lenticular and other Trusses, from fixed and moving loads, with practical applications and examples, for the use of Students and Engineers. By Samuel H. Shreve, A. M., Civil Engineer.

The Kansas City Bridge.

4to. Cloth. \$6.00

WITH AN ACCOUNT OF THE REGIMEN OF THE MISSOURI RIVER,—and a description of the Methods used for Founding in that River. By O. Chanute, Chief Engineer, and George Morison, Assistant Engineer. Illustrated with five lithographic views and twelve plates of plans.

Clarke's Quincy Bridge.

4to. Cloth. \$7.50.

DESCRIPTION OF THE IRON RAILWAY. Bridge across the Mississippi River at Quincy, Illinois. By Thomas Curtis Clarke, Chief Engineer. With twenty-one lithographed plans.

Whipple on Bridge Building.

New edition. 8vo. Illustrated. Cloth. \$4.

AN ELEMENTARY AND PRACTICAL TREATISE ON BRIDGE BUILDING.

By S. Whipple, C. E.

Roebling's Bridges.

Imperial folio. Cloth. \$25.00.

LONG AND SHORT SPAN RAILWAY BRIDGES. By John A. Roebling,
C. E. With large copperplate engravings of plans and views.

Dubois' Graphical Statics.

8vo. 60 Illustrations. Cloth. \$2.00.

THE NEW METHOD OF GRAPHICAL STATICS. By A. J. Dubois, C. E.,
Ph. D.

Eddy's Graphical Statics.

8vo. Illustrated. Cloth.

NEW CONSTRUCTIONS IN GRAPHICAL STATICS. By Prof. Henry T.
Eddy, C. E., Ph. D. With ten engravings in text and nine
folding plates.

Bow on Bracing.

156 Illustrations on Stone. 8vo. Cloth. \$1.50.

**A TREATISE ON BRACING,—with its application to Bridges and other
Structures of Wood or Iron.** By Robert Henry Bow, C. E.

Stoney on Strains.

New and Revised Edition, with numerous illustrations. Royal 8vo, 664 pp.
Cloth. \$12.50.

THE THEORY OF STRAINS IN GIRDERS—and Similar Structures, with
Observations on the Application of Theory to Practice, and Tables of
Strength and other Properties of Materials. By Bindon B. Stoney,
B. A.

Henrici's Skeleton Structures.

8vo. Cloth. \$1.50.

SKELETON STRUCTURES, especially in their Application to the building
of Steel and Iron Bridges. By OLAUS HENRICI.

Burgh's Modern Marine Engineering.

One thick 4to vol. Cloth. \$25.00. Half morocco. \$30.00.

MODERN MARINE ENGINEERING, applied to Paddle and Screw Propulsion. Consisting of 36 Colored Plates, 259 Practical Wood-cut Illustrations, and 403 pages of Descriptive Matter, the whole being an exposition of the present practice of the following firms: Messrs. J. Penn & Sons; Messrs. Maudslay, Sons & Field; Messrs. James Watt & Co.; Messrs. J. & G. Rennie; Messrs. R. Napier & Sons; Messrs. J. & W. Dudgeon; Messrs. Ravenhill & Hodgson; Messrs. Humphreys & Tenant; Mr. J. T. Spencer, and Messrs. Forrester & Co. By N. P. BURGH, Engineer.

King's Notes on Steam.

Nineteenth Edition. 8vo. \$2.00.

LESSONS AND PRACTICAL NOTES ON STEAM,—the Steam Engine, Propellers, &c., &c., for Young Engineers. By the late W. R. KING, U. S. N. Revised by Chief-Engineer J. W. KING, U. S. Navy.

Link and Valve Motions, by W. S. Auchincloss.

Sixth Edition. 8vo. Cloth. \$3.00.

APPLICATION OF THE SLIDE VALVE and Link Motion to Stationary, Portable, Locomotive and Marine Engines. By WILLIAM S. AUCHINCLOSS. Designed as a hand-book for Mechanical Engineers. Dimensions of the valve are found by means of a Printed Scale, and proportions of the link determined *without* the assistance of a model. With 37 wood-cuts and 21 lithographic plates, with copperplate engraving of the Travel Scale.

Bacon's Steam-Engine Indicator.

12mo. Cloth. \$1.00 Mor. \$1.50.

A TREATISE ON THE RICHARDS STEAM-ENGINE INDICATOR,—with directions for its use. By CHARLES T. PORTER. Revised, with notes and large additions as developed by American Practice, with an Appendix containing useful formulæ and rules for Engineers. By F. W. BACON, M. E., Illustrated. Second Edition.

Isherwood's Engineering Precedents.

Two Vols. in One. 8vo. Cloth. \$2.50.

ENGINEERING PRECEDENTS FOR STEAM MACHINERY.—By B. F. ISHERWOOD, Chief Engineer, U. S. Navy. With illustrations.

Slide Valve by Eccentrics, by Prof. C. W. MacCord.

4to. Illustrated. Cloth, \$3.00

A PRACTICAL TREATISE ON THE SLIDE VALVE BY ECCENTRICS,—examining by methods the action of the Eccentric upon the Slide Valve, and explaining the practical processes of laying out the movements, adapting the valve for its various duties in the steam-engine. For the use of Engineers, Draughtsmen, Machinists, and Students of valve motions in general. By C. W. MACCORD, A. M., Professor of Mechanical Drawing, Stevens' Institute of Technology, Hoboken, N. J.

Stillman's Steam-Engine Indicator.

12mo. Cloth. \$1.00

THE STEAM-ENGINE INDICATOR,—and the Improved Manometer Steam and Vacuum Gauges ; their utility and application. By PAUL STILLMAN. New edition.

Porter's Steam-Engine Indicator.

Third Edition. Revised and Enlarged. 8vo. Illustrated. Cloth. \$3.50.

A TREATISE ON THE RICHARDS STEAM-ENGINE INDICATOR,—and the Development and Application of Force in the Steam-Engine. By CHARLES T. PORTER.

McCulloch's Theory of Heat.

8vo. Cloth. 3.50.

A TREATISE ON THE MECHANICAL THEORY OF HEAT, AND ITS APPLICATIONS TO THE STEAM-ENGINE. By Prof. R. S. McCULLOCH, of the Washington and Lee University, Lexington, Va.

Van Buren's Formulas.

8vo. Cloth. \$2.00.

INVESTIGATIONS OF FORMULAS,—for the Strength of the Iron parts of Steam Machinery. By J. D. VAN BUREN, Jr., C. E. Illustrated.

Stuart's Successful Engineer.

18mo. Boards. 50 cents.

HOW TO BECOME A SUCCESSFUL ENGINEER. Being Hints to Youths intending to adopt the Profession. By BERNARD STUART, Engineer. Sixth Edition.

Stuart's Naval Dry Docks.

Twenty-four engravings on steel. Fourth edition. 4to. Cloth. \$6.00.

THE NAVAL DRY DOCKS OF THE UNITED STATES. By CHARLES B. STUART, Engineer in Chief U. S. Navy.

Ward's Steam for the Million.

8vo. Cloth. \$1.00.

STEAM FOR THE MILLION. A Popular Treatise on Steam and its Application to the Useful Arts, especially to Navigation. By J. H. WARD, Commander U. S. Navy.

Tunner on Roll-Turning.

1 vol. 8vo. and 1 vol. folio plates. \$10.00.

A TREATISE ON ROLL-TURNING FOR THE MANUFACTURE OF IRON, by PETER TUNNER. Translated by JOHN B. PEARSE, of the Pennsylvania Steel Works. With numerous wood-cuts, 8vo., together with a folio atlas of 10 lithographed plates of Rolls, Measurements, &c.

Grüner on Steel.

8vo. Cloth. \$3.50.

THE MANUFACTURE OF STEEL. By M. L. GRÜNER; translated from the French. By LENOX SMITH, A.M., E.M.; with an Appendix on the Bessemer Process in the United States, by the translator. Illustrated by lithographed drawings and wood-cuts.

Barba on the Use of Steel.

12mo. Illustrated. Cloth. \$1.50.

THE USE OF STEEL IN CONSTRUCTION. Methods of Working, Applying, and Testing Plates and Bars. By J. BARBA, Chief Naval Constructor. Translated from the French, with a Preface, by A. L. HOLLEY, P.B.

Bell on Iron Smelting.

8vo. Cloth. \$6.00.

CHEMICAL PHENOMENA OF IRON SMELTING. An experimental and practical examination of the circumstances which determine the capacity of the Blast Furnace, the Temperature of the Air, and the Proper Condition of the Materials to be operated upon. By I. LOWTHIAN BELL.

**The Useful Metals and their Alloys; Scoffren,
Truran, and others.**

Fifth Edition. 8vo. Half calf. \$3.75

THE USEFUL METALS AND THEIR ALLOYS, employed in the conversion of IRON, COPPER, TIN, ZINC, ANTIMONY, AND LEAD ORES, with their applications to the INDUSTRIAL ARTS. By JOHN SCOFFREN, WILLIAM TRURAN, WILLIAM CLAY, ROBERT OXLAND, WILLIAM FAIRBAIRN, W. C. AITKIN, and WILLIAM VOSE PICKETT.

Collins' Useful Alloys.

18mo. Flexible. 50 cents.

THE PRIVATE BOOK OF USEFUL ALLOYS and Memoranda for Goldsmiths, Jewellers, etc. By JAMES E. COLLINS.

Joynson's Metal Used in Construction.

12mo. Cloth. 75 cents.

THE METALS USED IN CONSTRUCTION: Iron, Steel, Bessemer Metal, etc., etc. By FRANCIS H. JOYNSON. Illustrated.

Dodd's Dictionary of Manufactures, etc.

12mo. Cloth. \$1.50.

DICTIONARY OF MANUFACTURES, MINING, MACHINERY, AND THE INDUSTRIAL ARTS. By GEORGE DODD.

Von Cotta's Ore Deposits.

8vo. Cloth. \$4.00.

TREATISE ON ORE DEPOSITS. By BERNHARD VON COTTA, Professor of Geology in the Royal School of Mines, Freiberg, Saxony. Translated from the second German edition, by FREDERICK PRIME, Jr., Mining Engineer, and revised by the author; with numerous illustrations.

Plattner's Blow-Pipe Analysis.

Third Edition. Revised. 568 pages. 8vo. Cloth. \$5.00.

PLATTNER'S MANUAL OF QUALITATIVE AND QUANTITATIVE ANALYSIS WITH THE BLOW-PIPE. From the last German edition, Revised and enlarged. By Prof. TH. RICHTER, of the Royal Saxon Mining Academy. Translated by Professor H. B. CORNWALL; assisted by JOHN H. CASWELL. With eighty-seven wood-cuts and Lithographic Plate.

Plympton's Blow-Pipe Analysis.

12mo. Cloth. \$1.50.

THE BLOW-PIPE: A Guide to its Use in the Determination of Salts and Minerals. Compiled from various sources, by GEORGE W. PLYMPTON, C.E., A.M., Professor of Physical Science in the Polytechnic Institute, Brooklyn, N.Y.

Pynchon's Chemical Physics.

New Edition. Revised and enlarged. Crown 8vo. Cloth. \$3.00.

INTRODUCTION TO CHEMICAL PHYSICS; Designed for the Use of Academies, Colleges, and High Schools. Illustrated with numerous engravings, and containing copious experiments, with directions for preparing them. By THOMAS RUGGLES PYNCHON, M.A., President of Trinity College, Hartford.

Eliot and Storer's Qualitative Chemical Analysis.

New Edition. Revised. 12mo. Illustrated. Cloth. \$1.50.

A COMPENDIOUS MANUAL OF QUALITATIVE CHEMICAL ANALYSIS. By CHARLES W. ELIOT and FRANK H. STORER. Revised, with the coöperation of the Authors, by WILLIAM RIPLEY NICHOLS, Professor of Chemistry in the Massachusetts Institute of Technology.

Rammelsberg's Chemical Analysis.

8vo. Cloth. \$2.25.

GUIDE TO A COURSE OF QUANTITATIVE CHEMICAL ANALYSIS, ESPECIALLY OF MINERALS AND FURNACE PRODUCTS. Illustrated by Examples. By C. F. RAMMELSBURG. Translated by J. TOWLER, M.D.

Naquet's Legal Chemistry.

Illustrated. 12mo. Cloth. \$2.00.

LEGAL CHEMISTRY. A Guide to the Detection of Poisons, Falsification of Writings, Adulteration of Alimentary and Pharmaceutical Substances; Analysis of Ashes, and Examination of Hair, Coins, Fire-arms, and Stains, as Applied to Chemical Jurisprudence. For the Use of Chemists, Physicians, Lawyers, Pharmacists, and Experts. Translated, with additions, including a List of Books and Memoirs on Toxicology, etc., from the French of A. NAQUET. By J. P. BATTERSHALL, Ph. D., with a Preface by C. F. CHANDLER, Ph. D., M.D., LL.D.

Prescott's Proximate Organic Analysis.

12mo. Cloth. \$1.75.

OUTLINES OF PROXIMATE ORGANIC ANALYSIS, for the Identification, Separation, and Quantitative Determination of the more commonly occurring Organic Compounds. By ALBERT B. PRESCOTT, Professor of Organic and Applied Chemistry in the University of Michigan.

Prescott's Alcoholic Liquors.

12mo. Cloth. \$1.50.

CHEMICAL EXAMINATION OF ALCOHOLIC LIQUORS.—A Manual of the Constituents of the Distilled Spirits and Fermented Liquors of Commerce, and their Qualitative and Quantitative Determinations. By ALBERT B. PRESCOTT, Professor of Organic and Applied Chemistry in the University of Michigan.

Prescott and Douglas's Qualitative Chemical Analysis.

Second Edition. Revised. 8vo. Cloth. \$3.50.

A Guide in the Practical Study of Chemistry and in the Work of Analysis.

Pope's Modern Practice of the Electric Telegraph.

Ninth Edition. 8vo. Cloth. \$2.00.

A Hand-book for Electricians and Operators. By FRANK L. POPE. Ninth edition. Revised and enlarged, and fully illustrated.

Sabine's History of the Telegraph.

Second Edition. 12mo. Cloth. \$1.25.

HISTORY AND PROGRESS OF THE ELECTRIC TELEGRAPH, with Descriptions of some of the Apparatus. By ROBERT SABINE, C.E.

Haskins' Galvanometer.

Pocket form. Illustrated. Morocco tucks. \$2.00.

THE GALVANOMETER, AND ITS USES;—A Manual for Electricians and Students. By C. H. HASKINS.

Larrabee's Secret Letter and Telegraph

18mo. Cloth. \$1.00.

CIPHER AND SECRET LETTER AND TELEGRAPHIC CODE, with Hogg's Improvements. By C. S. LARRABEE.

Gillmore's Limes and Cements.

Fifth Edition. Revised and Enlarged. 8vo. Cloth. \$4.00.

PRactical TREATISE ON LIMES, HYDRAULIC CEMENTS, AND MORTARS. By Q. A. GILLMORE, Lt.-Col. U. S. Corps of Engineers. Brevet Major-General U. S. Army.

Gillmore's Coignet Beton.

Nine Plates, Views, etc. 8vo. Cloth. \$2.50.

COIGNET BETON AND OTHER ARTIFICIAL STONE.—By Q. A. GILLMORE, Lt.-Col. U. S. Corps of Engineers, Brevet Major-General U.S. Army.

Gillmore on Roads.

Seventy Illustrations. 12mo. Cloth. \$2.00.

A PRACTICAL TREATISE ON THE CONSTRUCTION OF ROADS, STREETS, AND PAVEMENTS. By Q. A. GILLMORE, Lt.-Col. U. S. Corps of Engineers, Brevet Major-General U. S. Army.

Gillmore's Building Stones.

8vo. Cloth. \$1.00.

REPORT ON STRENGTH OF THE BUILDING STONES IN THE UNITED STATES, etc.

Holley's Railway Practice.

1 vol. folio. Cloth. \$12.00.

AMERICAN AND EUROPEAN RAILWAY PRACTICE, in the Economical Generation of Steam, including the materials and construction of Coal-burning Boilers, Combustion, the Variable Blast, Vaporization, Circulation, Super-heating, Supplying and Heating Feed-water, &c., and the adaptation of Wood and Coke-burning Engines to Coal-burning; and in Permanent Way, including Road-bed, Sleepers, Rails, Joint Fastenings, Street Railways, etc., etc. By ALEXANDER L. HOLLEY, B.P. With 77 lithographed plates.

Useful Information for Railway Men.

Pocket form. Morocco, gilt. \$2.00.

Compiled by W. G. HAMILTON, Engineer. New Edition, Revised and Enlarged. 577 pages.

Stuart's Civil and Military Engineers of America.

8vo. Illustrated. Cloth. \$5.00.

THE CIVIL AND MILITARY ENGINEERS OF AMERICA. By General CHARLES B. STUART, Author of "Naval Dry Docks of the United States," etc., etc. Embellished with nine finely-executed Portraits on steel of eminent Engineers, and illustrated by Engravings of some of the most important and original works constructed in America.

Ernst's Manual of Military Engineering.

193 Wood-cuts and 3 Lithographed Plates. 12mo. Cloth. \$5.00.

A MANUAL OF PRACTICAL MILITARY ENGINEERING. Prepared for the use of the Cadets of the U. S. Military Academy, and for Engineer Troops. By Capt. O. H. ERNST, Corps of Engineers, Instructor in Practical Military Engineering, U. S. Military Academy.

Simms' Levelling.

12mo. Cloth. \$2.50.

A TREATISE ON THE PRINCIPLES AND PRACTICE OF LEVELLING, showing its application to purposes of Railway Engineering and the Construction of Roads, etc. By FREDERICK W. SIMMS, C.E. From the fifth London edition, Revised and Corrected, with the addition of Mr. Law's Practical Examples for Setting-out Railway Curves. Illustrated with three lithographic plates and numerous wood-cuts.

Jeffers' Nautical Surveying.

Illustrated with 9 Copperplates and 31 Wood-cut Illustrations. 8vo. Cloth. \$5.00.

NAUTICAL SURVEYING. By WILLIAM N. JEFFERS, Captain U. S. Navy.

Text-book of Surveying.

8vo. 9 Lithograph Plates and several Wood-cuts. Cloth. \$2.00.

A TEXT-BOOK ON SURVEYING, PROJECTIONS, AND PORTABLE INSTRUMENTS, for the use of the Cadet Midshipmen, at the U. S. Naval Academy.

The Plane Table.

8vo. Cloth. \$2.00.

ITS USES IN TOPOGRAPHICAL SURVEYING. From the papers of the U. S. Coast Survey.

Chauvenet's Lunar Distances.

8vo. Cloth. \$2.00.

NEW METHOD OF CORRECTING LUNAR DISTANCES, and Improved Method of Finding the Error and Rate of a Chronometer, by equal altitudes. By WM. CHAUVENET, LL.D., Chancellor of Washington University of St. Louis.

Burt's Key to Solar Compass.

Second Edition. Pocket-book form. Tuck. \$2.50.

KEY TO THE SOLAR COMPASS, and Surveyor's Companion; comprising all the Rules necessary for use in the Field; also Description of the Linear Surveys and Public Land System of the United States, Notes on the Barometer, Suggestions for an Outfit for a Survey of Four Months, etc. By W. A. BURT, U. S. Deputy Surveyor.

Howard's Earthwork Mensuration.

8vo. Illustrated. Cloth. \$1.50.

EARTHWORK MENSURATION ON THE BASIS OF THE PRISMOIDAL FORMULÆ. Containing simple and labor-saving method of obtaining Prismoidal Contents directly from End Areas. Illustrated by Examples, and accompanied by Plain Rules for practical uses. By CONWAY R. HOWARD, Civil Engineer, Richmond, Va.

Morris' Easy Rules.

78 Illustrations. 8vo. Cloth. \$1.50.

EASY RULES FOR THE MEASUREMENT OF EARTHWORKS, by means of the Prismoidal Formula. By ELWOOD MORRIS, Civil Engineer.

Clevenger's Surveying.

Illustrated Pocket Form. Morocco, gilt. \$2.50.

A TREATISE ON THE METHOD OF GOVERNMENT SURVEYING, as prescribed by the U. S. Congress and Commissioner of the General Land Office. With complete Mathematical, Astronomical, and Practical Instructions for the use of the U. S. Surveyors in the Field, and Students who contemplate engaging in the business of Public Land Surveying. By S. V. CLEVINGER, U. S. Deputy Surveyor.

Hewson on Embankments.

8vo. Cloth. \$2.00.

PRINCIPLES AND PRACTICE OF EMBANKING LANDS from River Floods, as applied to the Levees of the Mississippi. By WILLIAM HEWSON, Civil Engineer.

Minifie's Mechanical Drawing.

Ninth Edition. Royal 8vo. Cloth. \$4.00.

A TEXT-BOOK OF GEOMETRICAL DRAWING, for the use of Mechanics and Schools. With illustrations for Drawing Plans, Sections, and Elevations of Buildings and Machinery; an Introduction to Isometrical Drawing, and an Essay on Linear Perspective and Shadows. With over 200 diagrams on steel. By WILLIAM MINIFIE, Architect. With an Appendix on the Theory and Application of Colors.

Minifie's Geometrical Drawing.

New Edition. Enlarged. 12mo. Cloth. \$2.00.

GEOMETRICAL DRAWING. Abridged from the octavo edition, for the use of Schools. Illustrated with 48 steel plates.

Free Hand Drawing.

Profusely Illustrated. 18mo. Boards. 50 cents.

A GUIDE TO ORNAMENTAL, Figure, and Landscape Drawing. By an Art Student.

The Mechanic's Friend.

12mo. Cloth. 300 Illustrations. \$1.50.

THE MECHANIC'S FRIEND. A Collection of Receipts and Practical Suggestions, relating to Aquaria—Bronzing—Cements—Drawing—Dyes—Electricity—Gilding—Glass-working—Glues—Horology—Lacquers—Locomotives—Magnetism—Metal-working—Modelling—Photography—Pyrotechny—Railways—Solders—Steam-Engine—Telegraphy—Taxidermy—Varnishes—Waterproofing—and Miscellaneous Tools, Instruments, Machines, and Processes connected with the Chemical and Mechanical Arts. By WILLIAM E. AXON, M.R.S.L.

Harrison's Mechanic's Tool-Book.

44 Illustrations. 12mo. Cloth. \$1.50.

MECHANICS' TOOL BOOK, with Practical Rules and Suggestions, for the use of Machinists, Iron Workers, and others. By W. B. HARRISON.

Randall's Quartz Operator's Hand-Book.

12mo. Cloth. \$2 00.

QUARTZ OPERATOR'S HAND-BOOK. By P. M. RANDALL. New edition, Revised and Enlarged. Fully illustrated.

Joynson on Machine Gearing.

8vo. Cloth. \$2.00.

THE MECHANIC'S AND STUDENT'S GUIDE in the designing and Construction of General Machine Gearing, as Eccentrics, Screws, Toothed Wheels, etc., and the Drawing of Rectilineal and Curved Surfaces. Edited by FRANCIS H. JOYNSON. With 18 folded plates.

Silversmith's Hand-Book.

Fourth Edition. Illustrated. 12mo. Cloth. \$3.00.

A PRACTICAL HAND-BOOK FOR MINERS, Metallurgists, and Assayers. By JULIUS SILVERSMITH. Illustrated.

Barnes' Submarine Warfare.

8vo. Cloth. \$5.00.

SUBMARINE WARFARE, DEFENSIVE AND OFFENSIVE. Descriptions of the various forms of Torpedoes, Submarine Batteries and Torpedo Boats actually used in War. Methods of Ignition by Machinery, Contact Fuzes, and Electricity, and a full account of experiments made to determine the Explosive Force of Gunpowder under Water. Also a discussion of the Offensive Torpedo system, its effect upon Iron-clad Ship systems, and influence upon future Naval Wars. By Lieut.-Com. JOHN S. BARNES, U.S.N. With twenty lithographic plates and many wood-cuts.

Foster's Submarine Blasting.

4to. Cloth. \$3.50.

SUBMARINE BLASTING, in Boston Harbor, Massachusetts—Removal of Tower and Corwin Rocks. By JOHN G. FOSTER, U. S. Eng. and Bvt. Major-General U. S. Army. With seven plates.

Mowbray's Tri-Nitro-Glycerine.

8vo. Cloth. Illustrated. \$3.00.

TRI-NITRO-GLYCERINE, as applied in the Hoosac Tunnel, and to Submarine Blasting, Torpedoes, Quarrying, etc.

Williamson on the Barometer.

4to. Cloth. \$15.00.

ON THE USE OF THE BAROMETER ON SURVEYS AND RECONNAISSANCES. Part I.—Meteorology in its Connection with Hypsometry. Part II.—Barometric Hypsometry. By R. S. WILLIAMSON, Bvt. Lt.-Col. U. S. A., Major Corps of Engineers. With illustrative tables and engravings.

Williamson's Meteorological Tables.

4to. Flexible Cloth. \$2.50.

PRACTICAL TABLES IN METEOROLOGY AND HYPSONOMETRY, in connection with the use of the Barometer. By Col. R. S. WILLIAMSON, U.S.A.

Butler's Projectiles and Rifled Cannon.

4to. 36 Plates. Cloth. \$7.50.

PROJECTILES AND RIFLED CANNON. A Critical Discussion of the Principal Systems of Rifling and Projectiles, with Practical Suggestions for their Improvement. By Capt. JOHN S. BUTLER, Ordnance Corps, U. S. A.

Benét's Chronoscope.

Second Edition. Illustrated. 4to. Cloth. \$3.00.

ELECTRO-BALLISTIC MACHINES, and the Schultz Chronoscope. By Lt.-Col. S. V. BENÉT, Chief of Ordnance U. S. A.

Michaelis' Chronograph

4to. Illustrated. Cloth. \$3.00.

THE LE BOULENGÉ CHRONOGRAPH. With three lithographed folding plates of illustrations. By Bvt. Captain O. E. MICHAELIS, Ordnance Corps, U. S. A.

Nugent on Optics.

12mo. Cloth. \$1.50.

TREATISE ON OPTICS; or, Light and Sight, theoretically and practically treated; with the application to Fine Art and Industrial Pursuits. By E. NUGENT. With 103 illustrations.

Peirce's Analytic Mechanics.

4to. Cloth. \$10.00.

SYSTEM OF ANALYTIC MECHANICS. By BENJAMIN PEIRCE, Professor of Astronomy and Mathematics in Harvard University.

Craig's Decimal System.

Square 32mo. Limp. 50c.

WEIGHTS AND MEASURES. An Account of the Decimal System, with Tables of Conversion for Commercial and Scientific Uses. By B. F. CRAIG, M.D.

Alexander's Dictionary of Weights and Measures.

New Edition. 8vo. Cloth. \$3.50.

UNIVERSAL DICTIONARY OF WEIGHTS AND MEASURES, Ancient and Modern, reduced to the standards of the United States of America. By J. H. ALEXANDER.

Elliot's European Light-Houses.

51 Engravings and 21 Wood-cuts. 8vo. Cloth. \$5.00.

EUROPEAN LIGHT-HOUSE SYSTEMS. Being a Report of a Tour of Inspection made in 1873. By Major GEORGE H. ELLIOT, U. S. Engineers.

Sweet's Report on Coal.

With Maps. 8vo. Cloth. \$3.00.

SPECIAL REPORT ON COAL. By S. H. SWEET.

Colburn's Gas Works of London.

12mo. Boards. 60 cents.

GAS WORKS OF LONDON. By ZERAH COLBURN.

Walker's Screw Propulsion.

8vo. Cloth. 75 cents.

NOTES ON SCREW PROPULSION, its Rise and History. By Capt. W. H. WALKER, U. S. Navy.

Pook on Shipbuilding.

8vo. Cloth. Illustrated. \$5.00.

METHOD OF PREPARING THE LINES AND DRAUGHTING VESSELS PROPELLED BY SAIL OR STEAM, including a Chapter on Laying-off on the Mould-loft Floor. By SAMUEL M. POOK, Naval Constructor.

Saeltzer's Acoustics.

12mo. Cloth. \$2.00.

TREATISE ON ACOUSTICS in connection with Ventilation. By ALEXANDER SAELTZER.

Eassie on Wood and its Uses.

250 Illustrations. 8vo. Cloth. \$1.50.

A HAND-BOOK FOR THE USE OF CONTRACTORS, Builders, Architects, Engineers, Timber Merchants, etc., with information for drawing up Designs and Estimates.

Wanklyn's Milk Analysis.

12mo. Cloth. \$1.00.

MILK ANALYSIS. A Practical Treatise on the Examination of Milk, and its Derivatives, Cream, Butter, and Cheese. By J. ALFRED WANKLYN, M.R.C.S.

Rice & Johnson's Differential Functions.

Paper, 12mo. 50 cents.

ON A NEW METHOD OF OBTAINING THE DIFFERENTIALS OF FUNCTIONS, with especial reference to the Newtonian Conception of Rates or Velocities. By J. MINOT RICE, Prof. of Mathematics, U. S. Navy, and W. WOOLSEY JOHNSON, Prof. of Mathematics, St. John's College, Annapolis.

Coffin's Navigation.

Fifth Edition. 12mo. Cloth. \$3.50.

NAVIGATION AND NAUTICAL ASTRONOMY. Prepared for the use of the U. S. Naval Academy. By J. H. C. COFFIN, Professor of Astronomy, Navigation and Surveying ; with 52 wood-cut illustrations.

Clark's Theoretical Navigation,

8vo. Cloth. \$3.00.

THEORETICAL NAVIGATION AND NAUTICAL ASTRONOMY. By LEWIS CLARK, Lieut.-Commander, U. S. Navy. Illustrated with 41 woodcuts, including the Vernier.

Toner's Dictionary of Elevations.

8vo. Paper, \$3.00 Cloth, \$3.75.

DICTIONARY OF ELEVATIONS AND CLIMATIC REGISTER OF THE UNITED STATES. Containing, in addition to Elevations, the Latitude, Mean Annual Temperature, and the total Annual Rain Fall of many Localities ; with a brief introduction on the Orographic and Physical Peculiarities of North America. By J. M. TONER, M.D.

VAN NOSTRAND'S SCIENCE SERIES.

It is the intention of the Publisher of this Series to issue them at intervals of about a month. They will be put up in a uniform, neat, and attractive form, 18mo, fancy boards. The subjects will be of an eminently scientific character, and embrace as wide a range of topics as possible, all of the highest character.

Price, 50 Cents Each.

- I. CHIMNEYS FOR FURNACES, FIRE-PLACES, AND STEAM BOILERS. By R. ARMSTRONG, C.E.
- II. STEAM BOILER EXPLOSIONS. By ZERAH COLBURN.
- III. PRACTICAL DESIGNING OF RETAINING WALLS. By ARTHUR JACOB, A.B. With Illustrations.
- IV. PROPORTIONS OF PINS USED IN BRIDGES. By CHARLES E. BENDER, C.E. With Illustrations.
- V. VENTILATION OF BUILDINGS. By W. F. BUTLER. With Illustrations.
- VI. ON THE DESIGNING AND CONSTRUCTION OF STORAGE RESERVOIRS. By ARTHUR JACOB. With Illustrations.
- VII. SURCHARGED AND DIFFERENT FORMS OF RETAINING WALLS. By JAMES S. TATE, C.E.
- VIII. A TREATISE ON THE COMPOUND ENGINE. By JOHN TURNBULL. With Illustrations.
- IX. FUEL. By C. WILLIAM SIEMENS, to which is appended the value of ARTIFICIAL FUELS AS COMPARED WITH COAL. By JOHN WORM-ALD, C.E.
- X. COMPOUND ENGINES. Translated from the French of A. MALLET. Illustrated.
- XI. THEORY OF ARCHES. By Prof. W. ALLAN, of the Washington and Lee College. Illustrated.
- XII. A PRACTICAL THEORY OF VOUSOIR ARCHES. By WILLIAM CAIN, C.E. Illustrated.

-
- XIII. A PRACTICAL TREATISE ON THE GASES MET WITH IN COAL MINES. By the late J. J. ATKINSON, Government Inspector of Mines for the County of Durham, England.
- XIV. FRICTION OF AIR IN MINES. By J. J. ATKINSON, author of "A Practical Treatise on the Gases met with in Coal Mines."
- XV. SKEW ARCHES. By Prof. E. W. HYDE, C.E. Illustrated with numerous engravings and three folded plates.
- XVI. A GRAPHIC METHOD FOR SOLVING CERTAIN ALGEBRAIC EQUATIONS. By Prof. GEORGE L. VOSE. With Illustrations.
- XVII. WATER AND WATER SUPPLY. By Prof. W. H. CORFIELD, M.A., of the University College, London.
- XVIII. SEWERAGE AND SEWAGE UTILIZATION. By Prof. W. H. CORFIELD, M.A., of the University College, London.
- XIX. STRENGTH OF BEAMS UNDER TRANSVERSE LOADS. By Prof. W. ALLAN, author of "Theory of Arches." With Illustrations
- XX. BRIDGE AND TUNNEL CENTRES. By JOHN B. McMASTERS, C.E. With Illustrations.
- XXI. SAFETY VALVES. By RICHARD H. BUEL, C.E. With Illustrations.
- XXII. HIGH MASONRY DAMS. By JOHN B. McMASTERS, C.E. With Illustrations.
- XXIII. THE FATIGUE OF METALS under Repeated Strains, with various Tables of Results of Experiments. From the German of Prof. LUDWIG SPANGENBERG. With a Preface by S. H. SHREVE, A.M. With Illustrations.
- XXIV. A PRACTICAL TREATISE ON THE TEETH OF WHEELS, with the theory of the use of Robinson's Odontograph. By S. W. ROBINSON, Prof. of Mechanical Engineering, Illinois Industrial University.
- XXV. THEORY AND CALCULATIONS OF CONTINUOUS BRIDGES. By MANSFIELD MERRIMAN, C.E. With Illustrations.
- XXVI. PRACTICAL TREATISE ON THE PROPERTIES OF CONTINUOUS BRIDGES. By CHARLES BENDER, C.E.

-
- XXVII. ON BOILER INCRUSTATION AND CORROSION. By J. F. Rowan.
- XXVIII. ON TRANSMISSION OF POWER BY WIRE ROPE. By Albert W. Stahl.
- XXIX. INJECTORS : THEIR THEORY AND USE. Translated from the French of M. Leon Pouchet.
- XXX. TERRESTRIAL MAGNETISM AND THE MAGNETISM OF IRON SHIPS. By Professor Fairman Rogers.
- XXXI. THE SANITARY CONDITION OF DWELLING HOUSES IN TOWN AND COUNTRY. By George E. Waring, Jr.

IN PRESS.

Heating and Ventilation in its Practical Application for the Use of Engineers and Architects.

Embracing a Series of Tables and Formulæ for dimensions for Heating Flow and Return Pipes, for Steam and Hot Water Boilers, Flues, etc., etc. By F. Schumann, C. E. 1 vol. 12mo. Illustrated.

A Guide to the Determination of Rocks.

Being an Introduction to Lithology. By Edward Jannettaz, Doctuer des Sciences. Translated from the French by Geo. W. Plympton, Professor of Physical Science, Brooklyn Polytechnic Institute. 12mo.

Shield's Treatise on Engineering Construction.

12mo. Cloth.

Embracing Discussions of the Principles involved and Descriptions of the Material employed in Tunnelling, Bridging, Canal and Road Building, etc., etc.

MILITARY BOOKS

PUBLISHED BY

D. VAN NOSTRAND,

23 Murray Street and 27 Warren Street,

NEW YORK.

Any Book in this Catalogue sent free by mail on receipt of price.

Benton's Ordnance and Gunnery.

Fourth Edition, Revised and Enlarged. 8vo. Cloth. \$5.00.

ORDNANCE AND GUNNERY. A Course of Instruction in Ordnance and Gunnery. Compiled for the use of the Cadets of the U. S. Military Academy, by Col. J. G. BENTON, Major Ordnance Dep., late Instructor of Ordnance and Gunnery, Military Academy, West Point. Illustrated.

Holley's Ordnance and Armor.

8vo. Half Roan, \$10.00. Half Russia, \$12.00.

A TREATISE ON ORDNANCE AND ARMOR. With an Appendix, referring to Gun-Cotton, Hooped Guns, etc., etc. By Alexander L. Holley, B. P. With 493 illustrations. 948 pages.

Scott's Military Dictionary.

8vo. Half Roan, \$6.00. Half Russia, \$8.00. Full Morocco, \$10.00.

MILITARY DICTIONARY. Comprising Technical Definitions; Information on Raising and Keeping Troops; Law, Government, Regulation, and Administration relating to Land Forces. By Col. H. L. Scott, U.S.A. 1 vol. Fully illustrated.

Roemer's Cavalry.

8vo. Cloth, \$6.00. Half Calf, \$7.50.

CAVALRY: ITS HISTORY, MANAGEMENT, AND USES IN WAR. By J. Roemer, LL.D., late an officer of Cavalry in the Service of the Netherlands. Elegantly illustrated with one hundred and twenty-seven fine wood engravings. Beautifully printed on tinted paper.

Michaelis' Chronograph.

4to. Illustrated. Cloth. \$3.00.

THE LE BOULENGE CHRONOGRAPH. With three lithographed folding plates of illustrations. By Brevet Capt. O. E. Michaelis, First Lieutenant Ordnance Corps, U. S. Army.

Benet's Chronoscope.

Second Edition. Illustrated. 4to. Cloth. \$3.00.

ELECTRO-BALLISTIC MACHINES., and the Schultz Chronoscope. By Genl. S. V. Benét, Chief of Ordnance, U. S. Army.

Dufour's Principles of Strategy and Grand Tactics.

12mo. Cloth. \$3.00.

THE PRINCIPLES OF STRATEGY AND GRAND TACTICS. Translated from the French of General G. H. Dufour. By William P. Craighill, U. S. Engr., and late Assistant Professor of Engineering, Military Academy, West Point. From the last French edition. Illustrated.

Jomini's Life of the Emperor Napoleon.

4 vols. 8vo., and Atlas. Cloth. Half Calf.

MILITARY AND POLITICAL LIFE OF THE EMPEROR NAPOLEON. By Baron Jomini, General-in-Chief and Aid-de-Camp to the Emperor of Russia. Translated from the French, with Notes, by H. W. Halleck, LL.D., Major-General U. S. Army. With 60 Maps and Plans.

Jomini's Campaign of Waterloo.

Third Edition. 12mo. Cloth. \$1.25.

THE POLITICAL AND MILITARY HISTORY OF THE CAMPAIGN OF WATERLOO. Translated from the French of General Baron de Jomini, by Genl. S. V. Benét, Chief of Ordnance.

Jomini's Grand Military Operations.

2 vols. 8vo., and Atlas. Cloth, \$15.00. Half Calf or Morocco, \$21. Half Russia, \$22.50.

TREATISE ON GRAND MILITARY OPERATIONS. Illustrated by a Critical and Military History of the Wars of Frederick the Great. With a Summary of the Most Important Principles of the Art of War. By Baron de Jomini. Illustrated by Maps and Plans. Translated from the French by Col. S. B. Holabird, A. D. C., U. S. Army.

Rodenbough's Everglade to Canon.

Royal 8vo. Illustrated with Chromo-Lithographs. Extra Cloth. \$7.50.

EVERGLADE TO CANON, with the Second Dragoons (Second U. S. Cavalry), an authentic account of service in Florida, Mexico, Virginia and the Indian Country, including Personal Recollections of Distinguished Officers. By Theo. F. Rodenbough, Colonel and Brevet Brigadier-General, U. S. Army.

History of Brevets.

Crown 8vo. Extra Cloth. \$3.50.

THE HISTORY AND LEGAL EFFECTS OF BREVETS in the Armies of Great Britain and the United States, from the origin in 1692 until the present time. By Gen. James B. Fry, U. S. Army.

Barre Duparcq's Military Art and History.

8vo. Cloth. \$5.00.

ELEMENTS OF MILITARY ART AND HISTORY. By Edward de la Barre Duparcq, Chef de Bataillon of Engineers in the Army of France, and Professor of the Military Art in the Imperial School of St. Cyr. Translated by Colonel Geo. W. Cullum, U. S. E.

Discipline and Drill of the Militia.

Crown 8vo. Flexible cloth. \$2.00.

THE DISCIPLINE AND DRILL OF THE MILITIA. By Major Frank S. Arnold, Assistant Quartermaster-General, Rhode Island.

Wallen's Service Manual.

12mo. Cloth. \$1.50.

SERVICE MANUAL for the Instruction of newly appointed Commissioned Officers, and the Rank and File of the Army, as compiled from Army Regulations, The Articles of War, and the Customs of Service. By Henry D. Wallen, Bvt. Brigadier-General U. S. Army.

Boynton's History of West Point.

Second Edition, 8vo. Fancy Cloth. \$3.50.

HISTORY OF WEST POINT, and its Military Importance during the American Revolution; and the Origin and Progress of the United States Military Academy. By Bvt. Maj. Edward C. Boynton, A. M., Adjutant of the Military Academy. With 36 Maps and Engraving

Wood's West Point Scrap-Book.

8vo. Extra Cloth. \$5.00

THE WEST POINT SCRAP-BOOK. Being a Collection of Legends, Stories, Songs, &c. By Lieut. O. E. Wood, U. S. A. With 69 wood-cut Illustrations. Beautifully printed on tinted paper.

West Point Life.

Oblong 8vo. Cloth, \$2.50.

WEST POINT LIFE. A Poem read before the Dialectic Society of the United States Military Academy. Illustrated with twenty-two full-page Pen and Ink Sketches. By A Cadet. To which is added the song, "Benny Havens, Oh!"

Gillmore's Fort Sumter.

8vo. Cloth. \$10.00. Half Russia, \$12.00.

GILLMORE'S FORT SUMTER. Official Report of Operations against the Defences of Charleston Harbor, 1863. Comprising the descent upon Morris Island, the Demolition of Fort Sumter, and the siege and reduction of Forts Wagner and Gregg. By Maj.-Gen. Q. A. Gillmore, U. S. Engineers. With 76 lithographic plates, views, maps, etc.

Gillmore's Supplementary Report on Fort Sumter.

8vo. Cloth. \$5.00.

SUPPLEMENTARY REPORT to the Engineer and Artillery Operations against the Defences of Charleston Harbor in 1863. By Maj.-Gen. Q. A. Gillmore, U. S. Engineers. With Seven Lithographed Maps and Views.

Gillmore's Fort Pulaski.

8vo. Cloth, \$2.50

SIEGE AND REDUCTION OF FORT PULASKI, GEORGIA. By Maj.-Gen. Q. A. Gillmore, U. S. Engineers. Illustrated by Maps and Views.

Barnard and Barry's Report.

8vo. Cloth, \$4.00.

REPORT OF THE ENGINEER AND ARTILLERY OPERATIONS OF THE ARMY OF THE POTOMAC, from its Organization to the Close of the Peninsular Campaign. By Maj.-Gen. J. G. Barnard, U. S. Engineers, and Maj.-Gen. W. F. Barry, Chief of Artillery. Illustrated by 18 Maps, Plans, &c.

Guide to West Point.

18mo. Flexible Cloth. \$1.00.

GUIDE TO WEST POINT AND THE U. S. MILITARY ACADEMY. With Maps and Engravings.

Barnard's C. S. A., and the Battle of Bull Run.

8vo. Cloth. \$2.00.

THE "C. S. A.," AND THE BATTLE OF BULL RUN. By Maj.-Gen. J. G. Barnard, U. S. Engineers. With five Maps.

Barnard's Peninsular Campaign.

8vo. Cloth. \$1.00. 12mo. Paper. 30c.

THE PENINSULAR CAMPAIGN AND ITS ANTECEDENTS, as developed by the Report of Maj.-Gen. Geo. B. McClellan, and other published Documents. By Maj.-Gen. J. G. Barnard, U. S. Engineers.

Barnard's Notes on Sea-Coast Defence.

8vo. Cloth. \$2.00.

NOTES ON SEA-COAST DEFENCE: Consisting of Sea-Coast Fortification; the Fifteen-Inch Gun; and Casemate Embrasure. By Major-Gen. J. G. Barnard, U. S. Engineers. With an engraved Plate of the 15-inch Gun.

Henry's Military Record of Civilian Appointments, U. S. A.

2 Vols. 8vo. Cloth. \$10.00.

MILITARY RECORD OF CIVILIAN APPOINTMENTS IN THE UNITED STATES ARMY. By Guy V. Henry, Brevet-Colonel U. S. A.

Harrison's Pickett's Men.

12mo. Cloth. \$2.00.

PICKETT'S MEN. A Fragment of War History. By Col. Walter Harrison. With portrait of Gen. Pickett.

Todleben's Defence of Sebastopol.

12mo. Cloth. \$2.00.

TODLEBEN'S (GENERAL) HISTORY OF THE DEFENCE OF SEBASTOPOL. By William Howard Russell, LL.D., of the London Times.

Hotchkiss and Allan's Battle of Chancellorsville.

8vo. Cloth. \$5.00.

THE BATTLE-FIELDS OF VIRGINIA. Chancellorsville, embracing the Operations of the Army of Northern Virginia. From the First Battle of Fredericksburg to the Death of Lt.-Gen. T. J. Jackson. By Jed. Hotchkiss and William Allan. Illustrated with five Maps and Portrait of Stonewall Jackson.

Andrews' Campaign of Mobile.

8vo. Cloth. \$3.50.

THE CAMPAIGN OF MOBILE, including the Co-operation of General Wilson's Cavalry in Alabama. By Brevet Maj.-Gen. C. C. Andrews. With five Maps and Views.

Stevens' Three Years in the Sixth Corps.

New and Revised Edition. 8vo. Cloth. \$3.00

THREE YEARS IN THE SIXTH CORPS. A concise narrative of events in the Army of the Potomac from 1861 to the Close of the Rebellion. April, 1865. By Geo. T. Stevens, Surgeon of the 77th Regt. New York Volunteers. Illustrated with 17 engravings and six steel portraits.

Lecomte's War in the United States.

12mo. Cloth. \$1.00.

THE WAR IN THE UNITED STATES. A Report to the Swiss Military Department. By Ferdinand Lecomte, Lieut.-Col. Swiss Confederation. Translated from the French by a Staff Officer.

Roberts' Hand-Book of Artillery.

16mo. Morocco Clasp. \$2.00.

HAND-BOOK OF ARTILLERY. For the service of the United States Army and Militia. Tenth edition, revised and greatly enlarged. By Joseph Roberts, Lt.-Col. 4th Artillery and Brevet. Maj.-General U. S. Army.

Instructions for Field Artillery.

12mo. Cloth. \$3.00.

INSTRUCTIONS FOR FIELD ARTILLERY. Prepared by a Board of Artillery Officers. To which is added the "Evolutions of Batteries," translated from the French, by Brig.-Gen. R. Anderson, U. S. A. 122 plates.

Heavy Artillery Tactics.

12mo. Cloth. \$2.50.

HEAVY ARTILLERY TACTICS.—1863. Instructions for Heavy Artillery; prepared by a Board of Officers, for the use of the Army of the United States. With service of a gun mounted on an iron carriage and 39 plates.

Andersons' Evolutions of Field Artillery.

24mo. Cloth. \$1.00.

EVOLUTIONS OF FIELD BATTERIES OF ARTILLERY. Translated from the French, and arranged for the Army and Militia of the United States. By Gen. Robert Anderson, U. S. A. Published by order of the War Department. 33 plates.

Duane's Manual for Engineering Troops.

12mo. Half Morocco. \$2.50.

MANUAL FOR ENGINEER TROOPS: Consisting of—Part I. Ponton Drill; II. Practical Operations of a Siege; III. School of the Sap; IV. Military Mining; V. Construction of Batteries. By General J. C. Duane, Corps of Engineers, U. S. Army. With 16 plates and numerous wood-cut illustrations.

Cullum's Military Bridges.

8vo. Cloth. \$3.50.

SYSTEMS OF MILITARY BRIDGES, in use by the United States Army; those adopted by the Great European Powers; and such as are employed in British India. With Directions for the Preservation, Destruction, and Re-establishment of Bridges. By Col. George W. Cullum, U. S. E. With 7 folding plates.

Mendell's Military Surveying.

12mo. Cloth. \$2.00.

A TREATISE ON MILITARY SURVEYING. Theoretical and Practical, including a description of Surveying Instruments. By G. H. Mendell, Major of Engineers. With 70 wood-cut illustrations.

Abbot's Siege Artillery Against Richmond.

8vo. Cloth. \$3.50.

SIEGE ARTILLERY IN THE CAMPAIGN AGAINST RICHMOND. By Henry L. Abbot, Major of U. S. Engineers. Illustrated.

Haupt's Military Bridges.

8vo. Cloth. \$6.50.

MILITARY BRIDGES; For the Passage of Infantry, Artillery and Baggage Trains; with suggestions of many new expedients and constructions for crossing streams and chasms. Including also designs for Trestle and Truss-Bridges for Military Railroads, adapted specially to the wants of the Service of the United States. By Herman Haupt, Brig.-Gen. U. S. A., author of "General Theory of Bridge Constructions," &c. Illustrated by 69 lithographic engravings.

Lendy's Maxims and Instructions on the Art of War.

18mo. Cloth. 75c.

MAXIMS AND INSTRUCTIONS ON THE ART OF WAR. A Practical Military Guide for the use of Soldiers of All Arms and of all Countries. Translated from the French by Captain Lendy, Director of the Practical Military College, late of the French Staff, etc., etc.

Benet's Military Law and Courts-Martial.

Sixth Edition, Revised and Enlarged. 8vo. Law Sheep. \$4.50.

BENET'S MILITARY LAW. A Treatise on Military Law and the Practice of Courts-Martial. By Gen. S. V. Benet, Chief of Ordnance U. S. A., late Assistant Professor of Ethics, Law, &c., Military Academy, West Point.

Lippitt's Special Operations of War.

Illustrated. 18mo. Cloth. \$1.00.

Lippitt's Field Service in War.

12mo. Cloth. \$1.00.

Lippitt's Tactical Use of the Three Arms.

12mo. Cloth. \$1.00.

Lippitt on Intrenchments.

41 Engravings. 12mo. Cloth. \$1.25.

Kelton's New Bayonet Exercise.

Fifth Edition. Revised. 12mo. Cloth. \$2.00.

NEW BAYONET EXERCISE. A New Manual of the Bayonet, for the Army and Militia of the United States. By General J. C. Kelton, U. S. A. With 40 beautifully engraved plates.

Craighill's Army Officers' Companion.

18mo. Full Roan. \$2.00.

THE ARMY OFFICERS' POCKET COMPANION. Principally designed for Staff Officers in the Field. Partly translated from the French of M. de Rouvre, Lieut.-Col. of the French Staff Corps, with additions from Standard American, French, and English authorities. By Wm. P. Craighill, Major U. S. Corps of Engineers, late Assistant Professor of Engineering at the U. S. Military Academy, West Point.

Casey's U. S. Infantry Tactics.

3 vols. 24mo. Cloth. \$2.50.

U. S. INFANTRY TACTICS. By Brig.-Gen. Silas Casey, U. S. A. 3 vols., 24mo. Vol. I.—School of the Soldier; School of the Company; Instruction for Skirmishers. Vol. II.—School of the Battalion. Vol. III.—Evolutions of a Brigade; Evolutions of a Corps d'Armée. Lithographed plates.

United States Tactics for Colored Troops.

24mo. Cloth. \$1.50.

U. S. TACTICS FOR COLORED TROOPS. U. S. Infantry Tactics for the use of the Colored Troops of the United States Infantry. Prepared under the direction of the War Department.

Morris' Field Tactics for Infantry.

Illustrated. 18mo. Cloth. 75c.

FIELD TACTICS FOR INFANTRY. By Brig.-Gen. Wm. H. Morris, U. S. Vols., late Second U. S. Infantry.

Monroe's Light Infantry and Company Drill.

32mo. Cloth. 75c.

LIGHT INFANTRY COMPANY AND SKIRMISH DRILL. Bayonet Fencing; with a Supplement on the Handling and Service of Light Infantry. By J. Monroe, Col. Twenty-Second Regiment, N. G., N. Y. S. M. formerly Captain U. S. Infantry.

Berriman's Sword Play.

Fourth Edition. 12mo. Cloth. \$1.00.

SWORD-PLAY. The Militiaman's Manual and Sword-Play without a Master. Rapier and Broad-Sword Exercises, copiously explained and illustrated; Small-Arm Light Infantry Drill of the United States Army; Infantry Manual of Percussion Musket; Company Drill of the United States Cavalry. By Major M. W. Berriman.

Morris' Infantry Tactics.

2 vols. 24mo. \$2.00. 2 vols. in 1. Cloth. \$1.50.

INFANTRY TACTICS. By Brig.-Gen. William H. Morris, U. S. Vols.,
and late U. S. Second Infantry.

Le Gal's School of the Guides.

16mo. Cloth. 60c.

THE SCHOOL OF THE GUIDES. Designed for the use of the Militia of
the United States. By Col. Eugene Le Gal.

Duryea's Standing Orders of the Seventh Regiment.

New Edition. 16mo. Cloth. 50c.

STANDING ORDERS OF THE SEVENTH REGIMENT NATIONAL GUARDS.
By A. Duryea, Colonel.

Heth's System of Target Practice.

18mo. Cloth. 75c.

SYSTEM OF TARGET PRACTICE; For the use of Troops when armed
with the Musket, Rifle-Musket, Rifle, or Carbine. Prepared princi-
pally from the French, by Captain Henry Heth, Tenth Infantry,
U. S. A.

Wilcox's Rifles and Rifle Practice.

New Edition. Illustrated. 8vo. Cloth. \$2.00.

RIFLES AND RIFLE PRACTICE. An Elementary Treatise on the Theory
of Rifle Firing; with descriptions of the Infantry Rifles of Europe
and the United States, their Balls and Cartridges. By Captain C. M.
Wilcox, U. S. A.

Viele's Hand-Book for Active Service.

12mo. Cloth. \$1.00.

HAND-BOOK FOR ACTIVE SERVICE, containing Practical Instructions in
Campaign Duties. For the use of Volunteers. By Brig.-Gen. Egbert
L. Viele, U. S. A.

Nolan's System for Training Cavalry Horses.

24 Plates. Cloth. \$2.00.

NOLAN'S SYSTEM FOR TRAINING CAVALRY HORSES. By Kenner Gar-
rard, Bvt. Brig.-Gen. U. S. A.

Arnold's Cavalry Service.

Illustrated 18mo. Cloth. 75c.

NOTES ON HORSES FOR CAVALRY SERVICE, embodying the Quality, Purchase, Care, and Diseases most frequently encountered, with lessons for biting the Horse, and bending the neck. By Bvt. Major A. K. Arnold, Capt. Fifth Cavalry, Assistant Instructor of Cavalry Tactics, U. S. Mil. Academy.

Cooke's Cavalry Practice.

100 Illustrations. 12mo. Cloth. \$1.00.

CAVALRY TACTICS; Regulations for the Instruction, Formation and Movements of the Cavalry of the Army and Volunteers of the United States. By Philip St. George Cooke, Brig.-Gen. U. S. A.

This is the edition now in use in the U. S. Army.

Patten's Cavalry Drill.

93 Engravings. 12mo. Paper. 50c.

CAVALRY DRILL. Containing Instructions on Foot; Instructions on Horseback; Basis of Instruction; School of the Squadron, and Sabre Exercise.

Patten's Infantry Tactics.

92 Engravings. 12mo. Paper. 50c.

INFANTRY TACTICS. School of the Soldier; Manual of Arms for the Rifle Musket; Instructions for Recruits, School of the Company; Skirmishers, or Light Infantry and Rifle Company Movements; the Bayonet Exercise; the Small-Sword Exercise; Manual of the Sword or Sabre.

Patten's Infantry Tactics.

Revised Edition. 100 Engravings. 12mo. Paper. 75c.

INFANTRY TACTICS. Contains Nomenclature of the Musket; School of the Company; Skirmishers, or Light Infantry and Rifle Company Movements; School of the Battalion; Bayonet Exercise; Small Sword Exercise; Manual of the Sword or Sabre.

Patten's Army Manual.

8vo. Cloth. \$2.00.

ARMY MANUAL. Containing Instructions for Officers in the Preparation of Rolls, Returns, and Accounts required of Regimental and Company Commanders, and pertaining to the Subsistence and Quartermaster's Department, &c., &c.

Patten's Artillery Drill.

12mo. Paper. 50c.

ARTILLERY DRILL. Containing instruction in the School of the Piece, and Battery Manœuvres, compiled agreeably to the Latest Regulations of the War Department. From Standard Military Authority. By George Patten, late U. S. Army.

Andrews' Hints to Company Officers.

18mo. Cloth. 60c.

HINTS TO COMPANY OFFICERS ON THEIR MILITARY DUTIES. By General C. C. Andrews, Third Regt., Minnesota Vols.

Thomas' Rifled Ordnance.

Fifth Edition, Revised. Illustrated. 8vo. Cloth. \$2.00.

RIFLED ORDNANCE; A Practical Treatise on the Application of the Principle of the Rifle to Guns and Mortars of every calibre. To which is added a new theory of the initial action and force of Fired Gunpowder. By Lynall Thomas, F. R. S. L.

Brinkerhoff's Volunteer Quartermaster.

12mo. Cloth. \$2.50.

THE VOLUNTEER QUARTERMASTER. By Captain R. Brinkerhoff, Post Quartermaster at Washington.

Hunter's Manual for Quartermasters and Commissaries.

12mo. Cloth. \$1.25. Flexible Morocco, \$1.50.

MANUAL FOR QUARTERMASTERS AND COMMISSARIES. Containing Instructions in the Preparation of Vouchers, Abstracts, Returns, etc. By Captain R. F. Hunter, late of the U. S. Army. 12mo. Cloth. \$1.25.

Greener's Gunnery.

8vo. Cloth. \$4.00. Full Calf. \$6.00.

GUNNERY IN 1858. A Treatise on Rifles, Cannon, and Sporting Arms. By Wm. Greener, R. C. E.

Head's System of Fortifications.

Illustrated. 4to. Paper. \$1.00.

A NEW SYSTEM OF FORTIFICATIONS. By George E. Head, A. M., Capt. Twenty-Ninth Infantry, and Bvt. Major U. S. A.

LIBRARY OF CONGRESS



0 021 218 355 6