

NATIONAL AERONAUTICS AND SPACE ADMINISTRATION

SPACE SHUTTLE MISSION STS-63

PRESS KIT
FEBRUARY 1995



SHUTTLE-MIR RENDEZVOUS
SPACEHAB-3; SPARTAN-204

STS-63 INSIGNIA

STS063-S-001 -- Designed by the crewmembers, the STS-63 insignia depicts the orbiter maneuvering to rendezvous with Russia's Space Station Mir. The name is printed in Cyrillic on the side of the station. Visible in the Orbiter's payload bay are the commercial space laboratory Spacehab and the Shuttle Pointed Autonomous Research Tool for Astronomy (SPARTAN) satellite which are major payloads on the flight. The six points on the rising sun and the three stars are symbolic of the mission's Space Transportation System (STS) numerical designation. Flags of the United States and Russia at the bottom of the insignia symbolize the cooperative operations of this mission.

The NASA insignia design for space shuttle flights is reserved for use by the astronauts and for other official use as the NASA Administrator may authorize. Public availability has been approved only in the form of illustrations by the various news media. When and if there is any change in this policy, which we do not anticipate, it will be publicly announced.

PHOTO CREDIT: NASA or National Aeronautics and Space Administration.

PUBLIC AFFAIRS CONTACTS

For Information on the Space Shuttle

Ed Campion NASA Headquarters Washington, DC	Policy/Management	202/358-1778
Rob Navias Johnson Space Center Houston, TX	Mission Operations Astronauts	713/483-5111
Bruce Buckingham Kennedy Space Center, Fl	Launch Processing KSC Landing Information	407/867-2468
June Malone Marshall Space Flight Center Huntsville, AL	External Tank/SRBs/SSMEs	205/544-0034
Cam Martin Dryden Flight Facility Edwards, CA	DFRF Landing Information	805/258-3448

For Information on STS-63 Experiments & Activities

Rob Navias Johnson Space Center Houston, TX	Mir Rendezvous & Fly Around	713/483-5111
Debra Rahn NASA Headquarters Washington, DC	International Cooperation	202/358-1639
Jim Cast NASA Headquarters Washington, DC	SPACEHAB-3	202/358-1779
Mike Braukus NASA Headquarters Washington, DC	SSCE	202/358-1979
Don Savage NASA Headquarters Washington, DC	SPARTAN-204	202/358-1547
Tammy Jones Goddard Space Flight Center Greenbelt, MD	CGP/ODERACS-II	301/286-5566

CONTENTS

GENERAL BACKGROUND

General Release	5
Media Services Information	7
Quick-Look Facts	8
Shuttle Abort Modes	10
Summary Timeline	11
Payload and Vehicle Weights	12
Orbital Events Summary	14
Crew Responsibilities	

CARGO BAY PAYLOADS & ACTIVITIES

Shuttle-Mir Rendezvous and Fly Around	16
SPARTAN-204	21
CGP/ODERACS	29
STS-63 Extravehicular Activities (EVA)	31

IN-CABIN PAYLOADS

SPACEHAB-3	32
Solid Surface Combustion Experiment (SSCE)	47
Air Force Maui Optical Site (AMOS)	48

STS-63 CREW BIOGRAPHIES

49

RELEASE: 95-5

RENDEZVOUS WITH RUSSIAN SPACE STATION HIGHLIGHTS FIRST SHUTTLE FLIGHT OF 1995

A significant step in the growing cooperative effort between the United States and Russia will take place during NASA's first Shuttle mission of the year when Discovery and her crew perform a rendezvous and fly around of the Russian Space Station Mir.

In addition, the STS-63 mission will see the third flight of the commercial SPACEHAB facility in which a number of microgravity research experiments will be conducted. Discovery's crew also will deploy and retrieve a free-flyer astronomy payload and two crew members will perform a five hour spacewalk.

The STS-63 crew will be commanded by James D. Wetherbee who will be making his third Shuttle flight. Eileen M. Collins will serve as pilot. She will be making her first spaceflight, becoming the first woman to pilot a Space Shuttle. The four mission specialists aboard Discovery will include Bernard A. Harris Jr., the Payload Commander and Mission Specialist-1 who will be making his second flight; Michael C. Foale, Mission Specialist-2 who will be making his third flight; Janice Voss, Mission Specialist-3 who will be making her second flight; and Cosmonaut Vladimir Georgievich Titov, Mission Specialist-4 who will be making his first flight aboard the Shuttle and fourth flight into space.

Launch of Discovery is currently targeted for February 2, 1995, at approximately 12:49 a.m. EST from Kennedy Space Center's Launch Complex 39-B. The actual launch time is expected to vary by several minutes based on new Mir state vectors for Shuttle rendezvous phasing requirements which will be updated closer to launch. The available window to launch Discovery is approximately 5 minutes each day. The STS-63 mission is scheduled to last 8 days, 6 hours, 13 minutes. A 12:49 a.m. launch on February 2 would produce a landing at Kennedy Space Center's Shuttle Landing Facility on February 10 at approximately 6:15 a.m. EST.

The Discovery crew's primary objective is to rendezvous with the Russian Space Station Mir in a dress rehearsal of missions that will follow later in 1995. The rendezvous is scheduled to take place on the fourth day of the mission and will serve to test the systems and techniques currently planned for the first Shuttle docking mission with Atlantis on Mission STS-71, currently scheduled for launch in June 1995.

The rendezvous will validate a number of flight techniques that will be employed on subsequent docking missions. These techniques include the use of precision flying as the Shuttle closes in on Mir, validating the use of a centerline camera for targeting the docking mechanism on Mir, verifying the absence of plume effects, demonstrating VHF radio communications, inspecting the Mir complex through photographs and video, and demonstrating the joint operations between Mission Control Centers in Houston, and Kaliningrad, Russia.

While the fly-around will provide valuable information for flight designers planning the docking missions, the completion of these objectives is not mandatory for the STS-71 mission.

The STS-63 mission will see the third flight of the SPACEHAB module, a pressurized, commercially-developed space research laboratory located in the forward end of Discovery's cargo bay. The SPACEHAB module significantly increases the pressurized working and storage volume normally available aboard the Shuttle. Over 20 SPACEHAB-3 experiments, sponsored by NASA's Offices of Space Access and Technology and Life and Microgravity Sciences and Applications together with the Department of Defense, represent a diverse cross-section of technological, biological and other scientific disciplines. These experiments were developed for flight by an equally-diverse complement of university, industry and government organizations nationwide.

Also being carried on Discovery is the Shuttle Pointed Autonomous Research Tool for Astronomy-204 (SPARTAN-204) designed to obtain data in the far ultraviolet region of the spectrum from diffuse sources of light.

Spartan 204's mission will occur in two distinct phases. The first phase will have the crew grapple the Spartan spacecraft with the robot arm and unberth it from its support structure. The crew then will conduct scientific observations by pointing Spartan at the Shuttle's tail to observe surface glow. It also will point at a primary Reaction Control System thruster to obtain far ultraviolet spectrographs of a thruster firing.

After the Mir rendezvous portion of the mission is complete, a crew member will again use the robot arm to lift the Spartan spacecraft from the payload bay and release it over the side of the Shuttle. It will be deployed from the Shuttle so that it can operate independently. For approximately 40 hours, Spartan 204's instrument will observe various celestial targets. Discovery will then rendezvous with Spartan 204 and the robot arm will be used to retrieve the payload.

The STS-63 mission will continue laying the groundwork for future space activities when Mission Specialists Mike Foale and Bernard Harris perform an almost five-hour spacewalk to test spacesuit modifications and practice handling large objects in microgravity.

The spacewalk has two specific objectives: to evaluate modifications to the spacesuits that provide astronauts with better thermal protection from cold and to perform several mass handling exercises in a series of activities designed to increase NASA's experience base as it prepares for the on-orbit assembly of the International Space Station.

Also being carried aboard Discovery will be a series of experiments that are part of the Hitchhiker Program, managed at NASA's Goddard Space Flight Center, Greenbelt, MD. The program is designed for customers who wish to fly quick- reaction and low-cost experiments on the Shuttle.

The first of four Hitchhiker missions scheduled for this year is CGP/ODERACS-II and will be aboard STS-63. This payload's acronym stems from the following experiments: Cryo System Experiment (CSE) whose overall goal is to validate and characterize the on-orbit performance of two thermal management technologies that comprise a hybrid cryogenic system; the Shuttle Glow (GLO-2) experiment which will investigate the mysterious shroud of luminosity, called the "glow phenomenon" observed by astronauts on past Shuttle missions; and the Orbital Debris Radar Calibration System-II (ODERACS-II) experiment which will provide a vehicle whereby small calibration targets are placed in Low Earth Orbit (LEO) for the purpose of calibrating ground-based radar and optical systems so that they may more accurately provide information regarding small debris in LEO.

The Solid Surface Combustion Experiment (SSCE) being flown on the Discovery is a continuing effort to study how flames spread in a microgravity environment. Comparing data on how flames spread in microgravity with knowledge of how flames spread on Earth may contribute to improvements in all types of fire safety and control equipment. This will be the eighth time SSCE has flown aboard the Shuttle, testing the combustion of different materials under different atmospheric conditions.

STS-63 will be the 20th flight of Discovery and the 67th flight of the Space Shuttle System.

(END OF GENERAL RELEASE; BACKGROUND INFORMATION FOLLOWS.)

MEDIA SERVICES INFORMATION

NASA Television Transmission

NASA Television is available through Spacenet-2 satellite system, transponder 5, channel 9, at 69 degrees West longitude, frequency 3880.0 MHz, audio 6.8 Megahertz.

The schedule for television transmissions from the Orbiter and for mission briefings will be available during the mission at Kennedy Space Center, FL; Marshall Space Flight Center, Huntsville, AL; Dryden Flight Research Center, Edwards, CA; Johnson Space Center, Houston; NASA Headquarters, Washington, DC; and the NASA newscenter operation at Mission Control-Moscow. The television schedule will be updated to reflect changes dictated by mission operations.

Television schedules also may be obtained by calling COMSTOR 713/483-5817. COMSTOR is a computer data base service requiring the use of a telephone modem. A voice update of the television schedule is updated daily at noon Eastern time.

Status Reports

Status reports on countdown and mission progress, on-orbit activities and landing operations will be produced by the appropriate NASA newscenter.

Briefings

A mission press briefing schedule will be issued prior to launch. During the mission, status briefings by a Flight Director or Mission Operations representative and when appropriate, representatives from the payload team, will occur at least once per day. The updated NASA television schedule will indicate when mission briefings are planned.

Access by Internet

NASA press releases can be obtained automatically by sending an Internet electronic mail message to domo@hq.nasa.gov. In the body of the message (not the subject line) users should type the words "subscribe press- release" (no quotes). The system will reply with a confirmation via E-mail of each subscription. A second automatic message will include additional information on the service.

Informational materials also will be available from a data repository known as an anonymous FTP (File Transfer Protocol) server at <ftp.pao.hq.nasa.gov> under the directory /pub/pao. Users should log on with the user name "anonymous" (no quotes), then enter their E-mail address as the password. Within the /pub/pao directory there will be a "readme.txt" file explaining the directory structure.

Access by fax

An additional service known as fax-on-demand will enable users to access NASA informational materials from their fax machines. Users calling (202) 358-3976 may follow a series of prompts and will automatically be faxed the most recent Headquarters news releases they request.

Access by Compuserve

Users with Compuserve accounts can access NASA press releases by typing "GO NASA" (no quotes) and making a selection from the categories offered.

STS-63 QUICK LOOK

Launch Date/Site: Feb. 2, 1995/KSC Pad 39B
Launch Time: 12:49 a.m. EST *
Launch Window: 5 minutes
Orbiter: Discovery (OV-103) - 20th flight
Orbit/Inclination: 170 nautical miles/51.6 degrees
Mission Duration: 8 days, 6 hours, 13 minutes
Landing Time/Date: 6:15 a.m. EST, Feb. 10, 1995
Primary Landing Site: Kennedy Space Center, Florida
Abort Landing Sites: Return to Launch Site - KSC
Transoceanic Abort Landing - Zaragoza, Spain
Moron, Spain
Ben Guerir, Morocco

Abort Once Around - KSC

Crew: Jim Wetherbee, Commander (CDR)
Eileen Collins, Pilot (PLT)
Bernard Harris, Payload Commander,
Mission Specialist 1 (MS 1)
C. Michael Foale, Mission Specialist 2 (MS 2)
Janice Voss, Mission Specialist 3 (MS 3)
Vladimir Titov, Mission Specialist 4 (MS 4)

Extravehicular Crewmembers: Foale (EV 1), Harris (EV 2)

Cargo Bay Payloads: SPACEHAB-03
SPARTAN-204
CGP-ODERACS-2 (Cryo Systems Experiment/Orbital Debris Radar Calibration Spheres)
ICBC (IMAX Cargo Bay Camera)

Middeck Payloads: SSCE (Solid Surface Combustion Experiment)

* Actual launch time is expected to vary by several minutes based on new Mir state vectors for Shuttle rendezvous phasing requirements which will be updated closer to launch.

Developmental Test Objectives/Detailed Supplementary Objectives:

DTO 301D:	Ascent Structural Capability Evaluation
DTO 305D:	Ascent Compartment Venting Evaluation
DTO 306D:	Descent Compartment Venting Evaluation
DTO 307D:	Entry Structural Capability
DTO 312:	External Tank Thermal Protection System Performance
DTO 319D:	Orbiter/Payload Acceleration and Acoustics Data
DTO 414:	APU Shutdown Test
DTO 524:	Landing Gear Loads and Brake Stability Evaluation
DTO 623:	Cabin Air Monitoring
DTO 671:	EVA Hardware for Future Scheduled EVA Missions
DTO 672:	EMU Electronic Cuff Checklist
DTO 700-2:	Laser Range and Range Rate Device
DTO 700-5:	Payload Bay Mounted Rendezvous Laser
DTO 700-7:	Orbiter Data for Real-Time Navigation Evaluation
DTO 805:	Crosswind Landing Performance
DTO 832:	Target of Opportunity Navigation Sensors
DTO 833:	EMU Thermal Comfort Evaluations
DTO 835:	Mir Approach Demonstration
DTO 836:	Tools for Rendezvous and Docking
DTO 838:	Near Field Targeting and Reflective Alignment System
DTO 1118:	Photographic and Video Survey of Mir Space Station
DTO 1210:	EVA Operations Procedures/Training
DSO 200B:	Radiobiological Effects
DSO 201B:	Sensory-Motor Investigations
DSO 204:	Visual Observations from Space
DSO 327:	Shuttle-Mir VHF Voice Link Verification
DSO 483:	Back Pain Pattern in Microgravity
DSO 484:	Assessment of Circadian Shifting in Astronauts by Bright Light
DSO 486:	Physical Examination in Space
DSO 487:	Immunological Assessment of Crewmembers
DSO 491:	Characterization of Microbial Transfer Among Crewmembers During Flight
DSO 492:	In-Flight Evaluation of a Portable Clinical Blood Analyzer
DSO 604:	Visual-Vestibular Integration as a Function of Adaptation
DSO 608:	Effects of Space Flight on Aerobic and Anaerobic Metabolism
DSO 621:	In-Flight Use of Florinef to Improve Orthostatic Intolerance Postflight
DSO 626:	Cardiovascular and Cerebrovascular Responses to Standing Before and After Space Flight
DSO 901:	Documentary Television
DSO 902:	Documentary Motion Picture Photography
DSO 903:	Documentary Still Photography

SPACE SHUTTLE ABORT MODES

Space Shuttle launch abort philosophy aims toward safe and intact recovery of the flight crew, Orbiter and its payload. Abort modes for STS-63 include:

- Abort-To-Orbit (ATO) -- Partial loss of main engine thrust late enough to permit reaching a minimal 105-nautical mile orbit with the orbital maneuvering system engines.
- Abort-Once-Around (AOA) -- Earlier main engine shutdown with the capability to allow one orbit of the Earth before landing at the Kennedy Space Center, FL.
- Transatlantic Abort Landing (TAL) -- Loss of one or more main engines midway through powered flight would force a landing at either Zaragoza, Spain; Moron, Spain; or Ben Guerir, Morocco.
- Return-To-Launch-Site (RTL) -- Early shutdown of one or more engines, and without enough energy to reach Zaragoza, would result in a pitch around and thrust back toward Kennedy until within gliding distance of the Shuttle Landing Facility.

STS-63 SUMMARY TIMELINE

Flight Day 1

Ascent
OMS-2 Burn
SPACEHAB activation
ODERACS deploy
RMS checkout

Flight Day 2

SPACEHAB experiments
SPARTAN attached operations

Flight Day 3

SPACEHAB experiments
Mir Rendezvous Burns

Flight Day 4

Mir Rendezvous

Flight Day 5

SPARTAN Deploy
SPACEHAB experiments

Flight Day 6

EMU checkout
Flight Control Systems Checkout
SPARTAN Rendezvous Burns

Flight Day 7

EVA Prep
SPARTAN Rendezvous and Retrieval
EVA

Flight Day 8

SPACEHAB experiments
Crew News Conference
Cabin Stow

Flight Day 9

Deorbit Prep
Deorbit Burn
Entry
Landing

PAYLOAD AND VEHICLE WEIGHTS

	<u>Pounds</u>
Orbiter (Discovery) empty and 3 SSMEs	173,716
Spacehab-03	8,765
Spacehab Support Equipment	662
Spartan 204 Airborne Support Equipment	2,409
Spartan 204 Deployable Payload	2,572
CGP/ODERACS-2	4,406
Solid Surface Combustion Experiment	139
Detailed Test/Supplementary Objectives	247
Shuttle System at SRB Ignition	4,511,889
Orbiter Weight at Landing	211,318

STS-63 ORBITAL EVENTS SUMMARY

(Based on a Feb. 2, 1995 Launch)

Event	MET	Time of Day (EST)
OMS-2	0/00:42	1:39 AM, Feb. 2
SPACEHAB Activation	0/02:30	3:21 AM, Feb. 2
ODERACS Deploy	0/03:40	4:31 AM, Feb. 2
RMS Checkout	0/06:10	7:01 AM, Feb. 2
SPARTAN Unberth (Attached RMS Operations)	1/01:00	1:51 AM, Feb. 3
SPARTAN Berth	1/07:00	7:51 AM, Feb. 3
TI-Burn, Mir	3/10:55	11:55 AM, Feb. 5
V-Bar Arrival, Mir	3/12:35	1:26 PM, Feb. 5
30-Foot Stationkeeping	3/13:22	2:19 PM, Feb. 5
Separation Burn	3/14:45	3:36 PM, Feb. 5
SPARTAN Deploy	4/06:45	7:36 AM, Feb. 6
EMU Checkout	5/03:00	3:51 AM, Feb. 7
FCS Checkout	5/05:05	5:56 AM, Feb. 7
EVA Prep	6/00:00	12:51 AM, Feb. 8
TI-Burn, SPARTAN	6/03:35	4:26 AM, Feb. 8
SPARTAN Grapple	6/05:45	6:36 AM, Feb. 8
EVA Begins	6/06:30	7:21 AM, Feb. 8
EVA Ends	6/11:10	12:01 PM, Feb. 8
Crew News Conference	7/02:55	3:46 AM, Feb. 9
SPACEHAB Deactivation	7/07:50	8:41 AM, Feb. 9
Deorbit Burn	8/05:13	6:04 AM, Feb. 10
KSC Landing	8/06:13	7:04 AM, Feb. 10

STS-63 CREW RESPONSIBILITIES

Task/Payload	Primary	Backups/Others
Primary Payloads/Activities		
Mir Rendezvous Operations	Wetherbee	Collins, Foale
Spacehab-3	Harris	Titov, Voss
Spartan-204	Foale	Voss
Secondary Payloads		
CSE	Wetherbee	
GLO-2	Wetherbee	Collins
ODERACS-2	Wetherbee	Collins, Harris
AMOS	Wetherbee	Collins
CONCAP-II	Wetherbee	Collins
ICBC	Voss	Titov
MSX	Collins	Wetherbee
SSCE	Foale	Titov
CTOS	Harris	Voss
Spacehab-3 Experiments		
ASC-IV	Titov	Voss, Harris
BRIC-03	Foale	Voss
BPL-03	Wetherbee	Collins, Harris
CHARLOTTE	Titov	Voss, Harris
CHROMEX-06	Titov	Voss, Harris
CGBA-05	Titov	Harris, Voss
CPCG-VDA	Voss	Titov
CREAM-06	Wetherbee	Foale, Titov
ECLiPSE-HAB-3	Harris	Titov
F-GBA	Wetherbee	Collins, Harris
GPPM-02	Voss	Harris
IMMUNE-02	Harris	Titov, Foale, Voss
NIH-C-03	Harris	Foale
PCG-STES-03	Voss	Foale, Titov
PCF-LST-03	Harris	Voss
RME-III-13	Wetherbee	Foale
SAMS-03	Foale	Wetherbee,
3-DMA	Collins	Titov
WINDEX-01	Foale	Collins, Titov

DTOs/DSOs

Task Payload	Primary	Backups/Others
DSO 200B (Radiobio Effects)	All	
DSO 201B (Sensory-Motor)	Wetherbee, Collins, Harris, Foale, Voss, Titov	
DSO 204 (Visual Observ.)	Titov, Foale	
DSO 483 (Back Pain Pattern)	Collins, Foale, Voss	
DSO 484 (Circadian Shifting)	Wetherbee, Collins, Voss, Titov	
DSO 486 (Physical Exam)	Wetherbee, Collins, Harris (doctor), Foale, Voss, Titov	
DSO 487 (Immun. Assessment)	All	
DSO 491 (Microbial Transfer)	All	
DSO 492 (Blood Analyzer)	Wetherbee, Harris, Voss	
DSO 608 (Ergometer)	Harris, Foale	
Photography/TV	Foale	Titov
In-Flight Maintenance	Titov	Foale
Earth Observations	Titov	Foale
RMS	Voss	Titov, Foale
Medical	Harris	Foale

SHUTTLE MIR RENDEZVOUS AND FLY AROUND

STS-63's primary objective is to rendezvous with the Russian Space Station Mir in a dress rehearsal of cooperative missions that will follow later in 1995. The approach will serve to test the systems and techniques currently planned for the first Shuttle docking mission, STS-71, currently scheduled for June 1995.

The rendezvous sequence will begin about nine hours into the mission when a reaction control system jet firing adjusts the rate at which Discovery is closing on Mir. Over the next few days, additional burns will gradually bring Discovery to within eight nautical miles behind Mir. At this point, the Ti burn is fired and the final phase of the rendezvous begins. Discovery will close the final 8 nautical miles to Mir during the next one-and-a-half-hour orbit. At this point, the Shuttle's rendezvous radar system begins providing range and closing rate information to the crew.

The manual phase of the operation begins just after Discovery passes about a half-mile below Mir when Commander Jim Wetherbee takes the controls at a distance of about 2,000 feet. Wetherbee will be flying the Shuttle from the aft flight deck controls as Discovery circles up to intersect the velocity vector of Mir. The velocity vector, also known as the V-Bar, is an imaginary line drawn along Mir's direction of travel.

Wetherbee will stop Discovery's approach when the Shuttle reaches a point about 400 feet directly in front of Mir.

After the Shuttle moves to within 1,000 feet of Mir, Discovery's steering jets will be fired in a mode called "Low Z". This approach uses braking jets that are slightly offset to the Mir rather than steering jets pointed directly at the Station, thus avoiding contaminating or damaging the Station. Also, as Discovery reaches close proximity to Mir, the Trajectory Control Sensor, a laser ranging device mounted in the payload bay, will supplement the navigation information by supplying data on the Shuttle's range and closing rate to Mir.

Discovery will maintain its position 400 feet in front of Mir until Flight Control teams in Russia give a "go" for the Shuttle's approach. Wetherbee will then slowly fly the Orbiter from 400 feet to a point about 30 feet from Mir, aligning with the Station's docking module in a rehearsal of a docking approach planned for Shuttle mission STS-71. To assist with the alignment, Wetherbee will watch the approach from a centerline television camera, mounted in the upper window of the Spacehab module, on a monitor in the aft flight deck. When within about 200 feet of Mir, Discovery will begin air-to-air communications with cosmonauts on Mir using a VHF radio system.

At 30 feet from the docking port, Wetherbee will again stationkeep, rehearsing a maneuver to orient Discovery properly to the docking port, before slowly backing the Orbiter away from Mir.

When Discovery is again about 400 feet from Mir, Wetherbee will begin a slow fly-around, maintaining a distance of about 450 feet from Mir. Discovery will completely circle Mir once over the next 45 minutes.

The two spacecraft will begin the separation sequence when Discovery reaches a point about 450 feet above Mir for the second time. The Orbiter will then fire its steering jets in a maneuver that will put it on a course to eventually take it ahead of Mir as Discovery opens the distance between the two spacecraft with each orbit. Throughout the operation, Discovery's crew will use video and still cameras to document the exterior of the Mir.

The rendezvous will validate a number of flight techniques that will be employed on subsequent docking missions. These techniques include the use of precision flying as the Shuttle closes in on Mir, validating the use of a centerline camera for targeting the docking mechanism on Mir, verifying the absence of plume effects, demonstrating VHF radio communications, inspecting the Mir complex through photographs and video, and demonstrating the joint operations between Mission Control Centers in Houston, and Kaliningrad, Russia.

While the fly-around will provide valuable information for flight designers planning the docking missions, the completion of these objectives is not mandatory in preparation for the STS-71 mission.

MIR RENDEZVOUS PROFILE

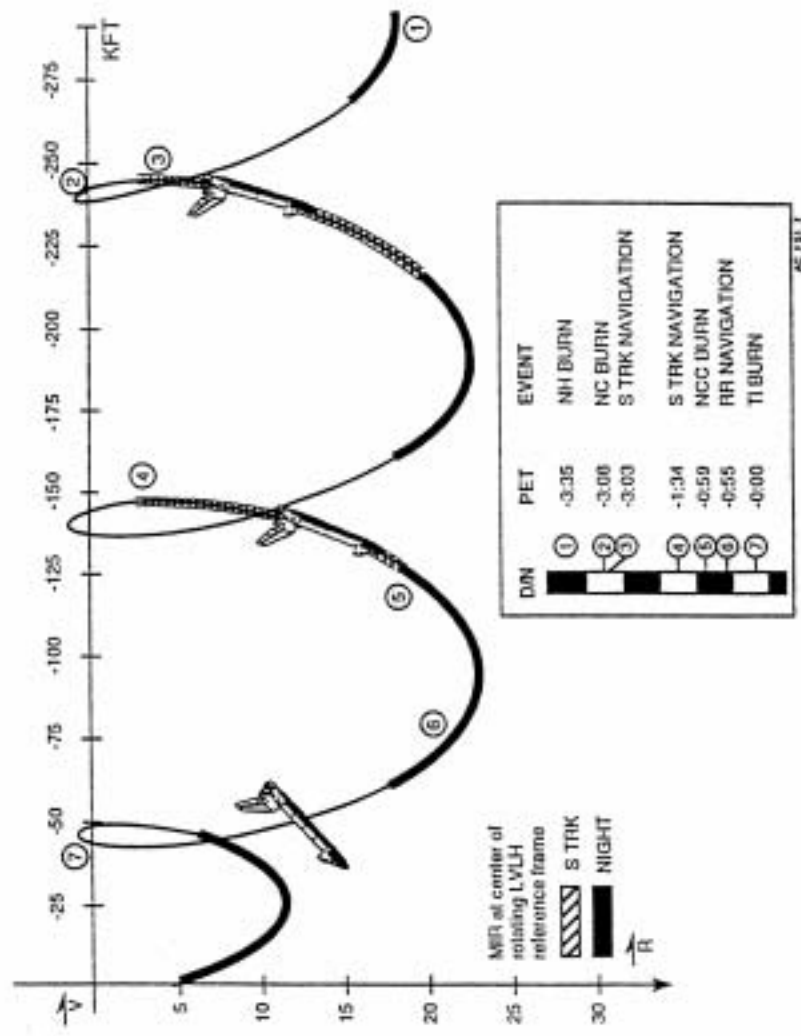

MIR FLY-BY

MIR POST TI PROFILE

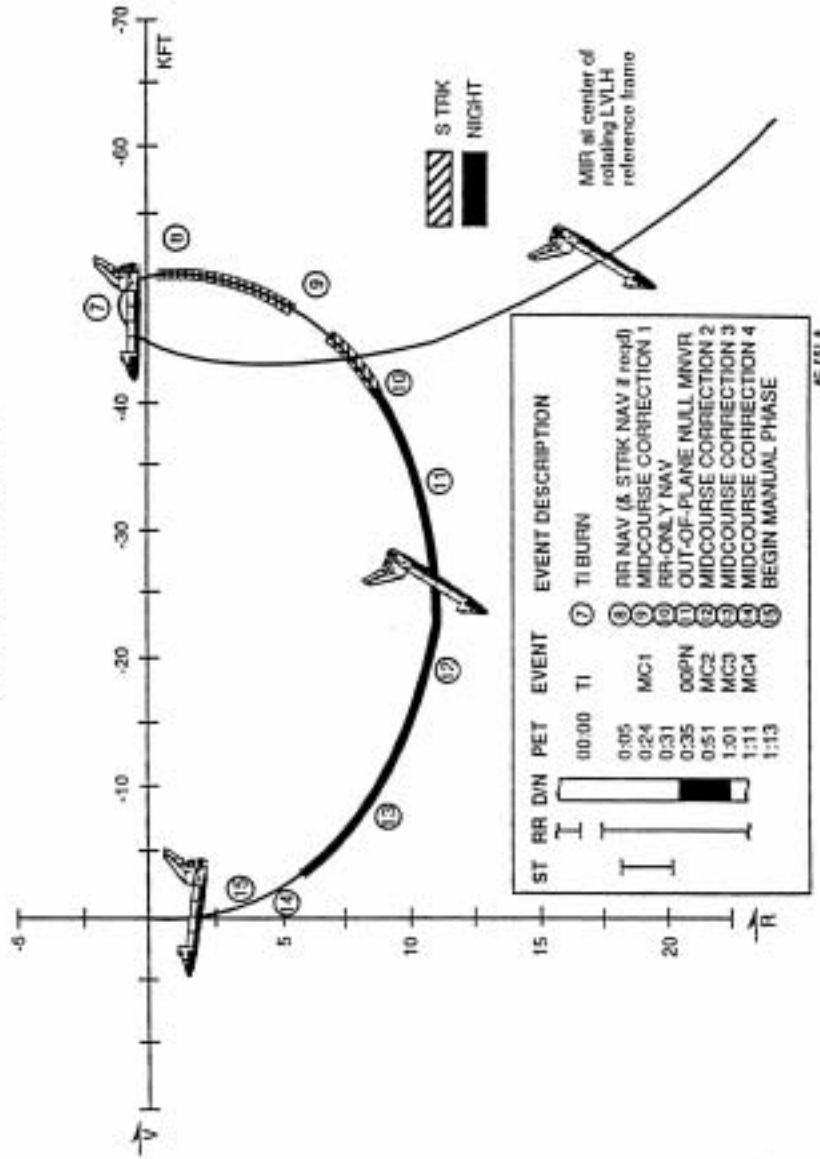

MIR FLY-BY

MIR BACKAWAY, FLYAROUND, AND SEPARATION

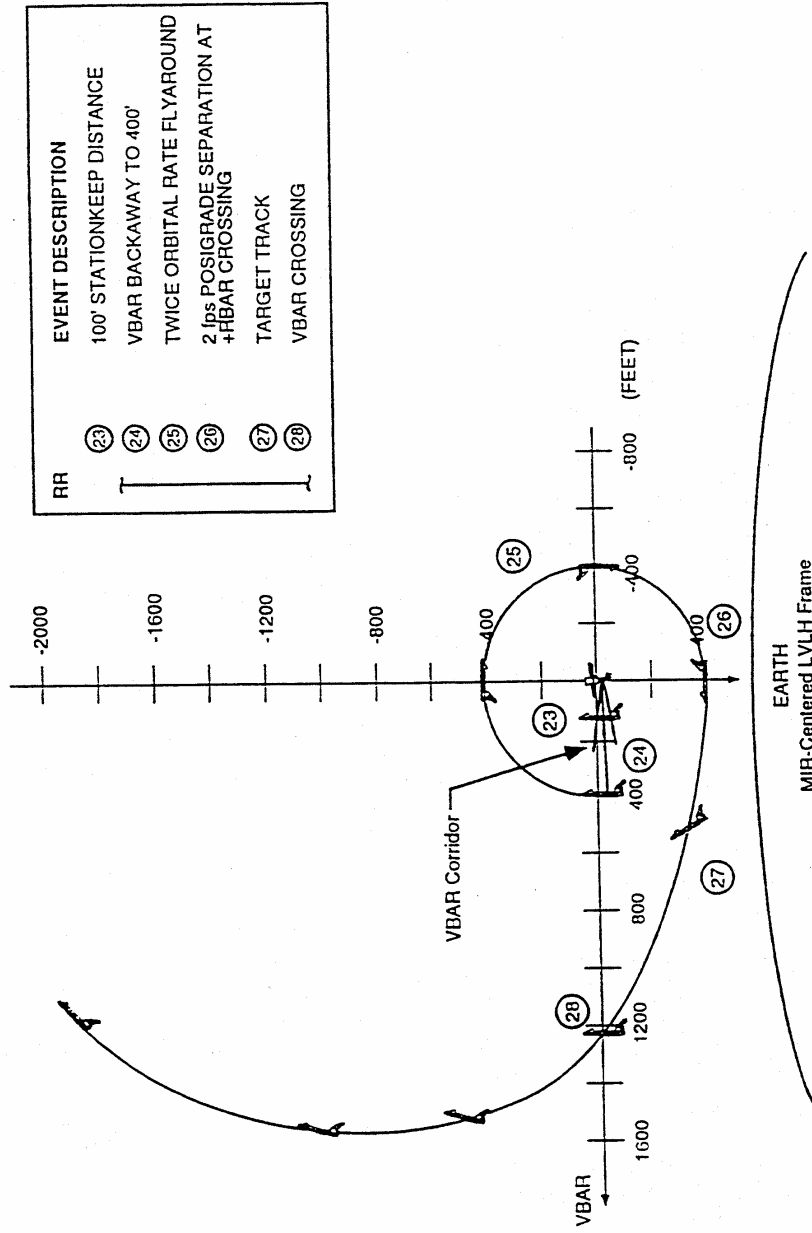

MIR FLY-BY

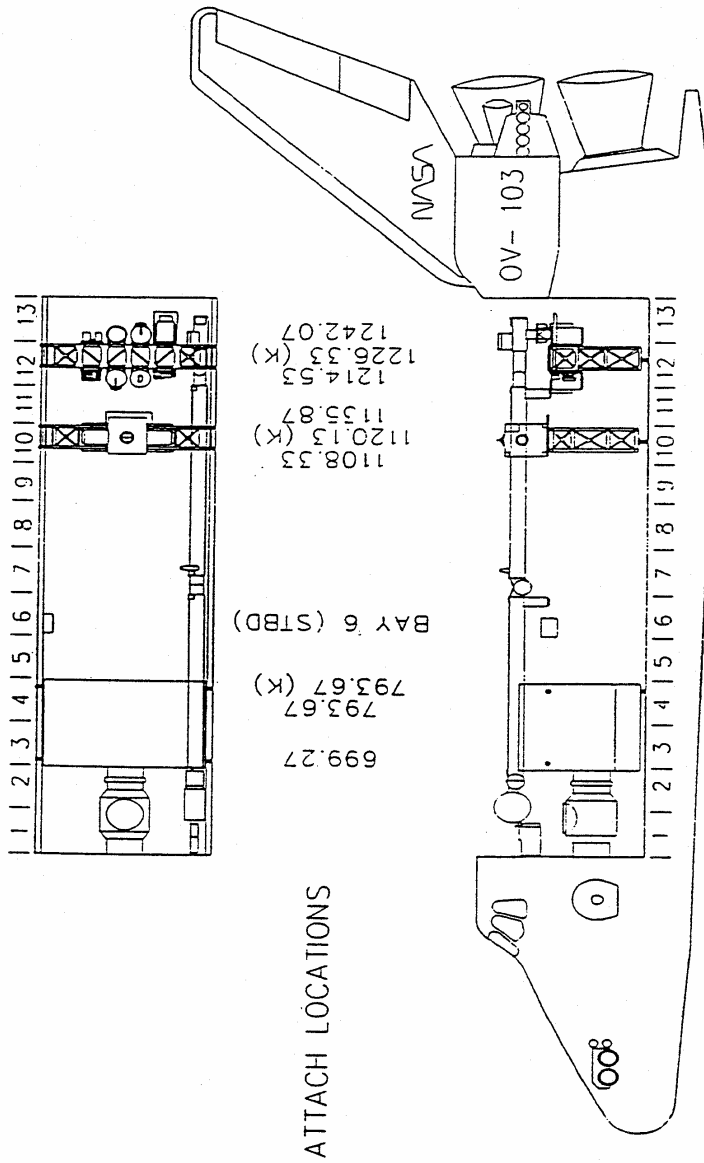

STS-63 PAYLOAD CONFIGURATION

SPARTAN 204

Background

The Spartan program is designed to provide easy and relatively inexpensive access to Earth orbit via the Space Shuttle for science experiments. Spartan's design consists of a basic carrier, which, with the addition of a science experiment, becomes a complete spacecraft designed to meet specific science objectives on each mission. Spartan missions include stellar, solar, Earth fine-pointing, and microgravity science and technology experiments requiring space environments away from the Space Shuttle.

The Spartan program was conceived in the mid-1970s and developed by the Special Payloads Division, Goddard Space Flight Center (GSFC), Greenbelt, MD, and the U.S. Naval Research Laboratory, Washington, DC, to extend the capabilities of sounding rocket-class science experiments by making use of the Space Shuttle.

In June 1985, a Spartan mission successfully carried an X-Ray telescope aboard STS-51G. Another carrier, Spartan Halley, was on board Shuttle Mission STS-51L. In April 1993 and September 1994, Spartan 201 was flown aboard the Space Shuttle Discovery on missions STS-56 and STS-64. This is the first flight of the Spartan 204 carrier system.

SPARTAN 204 Mission

Spartan 204 will obtain data in the far ultraviolet region of the spectrum from diffuse sources of light. For this mission, the Spartan 204 spacecraft is designed to operate both while attached to the Shuttle's Remote Manipulator System (RMS) or robot arm, and in free-flight away from the Orbiter.

Spartan 204's mission will occur in two distinct phases. The first phase will be on flight day 2, when the crew will grapple the Spartan spacecraft with the robot arm and unberth it from its support structure. The crew then will conduct scientific observations for about 4.5 hours by pointing Spartan at the Shuttle's tail to observe surface glow. It also will point at a primary Reaction Control System thruster to obtain far ultraviolet spectrographs of a thruster firing. After these operations Spartan will be reberthed in the Orbiter bay as other Shuttle operations take place.

The second phase of Spartan 204 operations will begin on Flight Day 5, when the free-flight operations begin. The crew will prepare Spartan by again grappling it with the robot arm and unberthing it from its support structure. Spartan then will be released from the robot arm, and the Orbiter will back away from the Spartan free-flyer spacecraft.

Spartan will operate autonomously in free-flight for a mission duration of approximately 43.5 hours following a pre-programmed science mission, providing its own battery power, pointing system and recorder for capturing data. The scientific observations will be recorded on film on board Spartan 204, and analyzed by scientists and engineers after it is returned from space.

After its free-flyer mission ends on Flight Day 7, the Orbiter will fly back to the Spartan 204 spacecraft, retrieve it with the robot arm, and power it off. The Spartan spacecraft will be reberthed in the Orbiter bay, completing its scientific mission.

SPARTAN 204 Science

The Far Ultraviolet Imaging Spectrograph (FUVIS) experiment objectives are to study astronomical and artificially-induced sources of diffuse far-ultraviolet radiation. The astronomical diffuse sources include nebulae, celestial diffuse background radiation and nearby external galaxies. The artificial sources include emissions associated with the Orbiter -- the recently discovered Shuttle surface glow and emissions due to Shuttle Reaction Control system rocket engines.

The FUVIS astrophysical science objectives are primarily concerned with improving scientific understanding of the composition, physical and chemical properties, and distribution in space of the interstellar medium.

The interstellar medium is the gas and dust which fills the space between the stars, and which is the material from which new stars and planets are formed.

The Orion Nebula is an example of a cloud of interstellar material which is excited to glow by the far-ultraviolet light emitted by the very hot stars embedded within it. The Cygnus Loop is an example of a supernova remnant - a shell of interstellar gas which is excited to glow by the outwardly-moving shock wave produced by a stellar explosion -- a supernova -- which occurred about 50,000 years ago.

The unique features of FUVIS are that it observes in the far-ultraviolet region of the electromagnetic spectrum, which can provide new information unobtainable in other spectral regions, and it is optimized for the study of diffuse sources rather than point sources (e.g., stars). However, since FUVIS is an imaging spectrograph, it also can obtain spectra of stars for in-flight calibration, and can separate out the contributions of stars from those of truly diffuse sources.

The FUVIS instrument is designed to provide the highest possible diffuse source sensitivity in the far-ultraviolet, but also provides efficient means for study of large, faint galactic nebulae such as the Barnard Loop, North America, and Cygnus Loop nebulae, comets, and diffuse emissions associated with the Shuttle. It also is capable of mapping nearby galaxies such as the Magellanic Clouds and the Andromeda Galaxy.

Detailed FUVIS plans include observations of stellar UV radiation which is scattered by interstellar dust particles to obtain information on the physical properties, composition, and spatial distribution of the dust; and of emission lines from the gaseous phases of the interstellar medium; i.e., diffuse nebulae and the general interstellar medium, which provides information on gas temperature, composition, and spatial distribution.

Department of Defense objectives include studies to determine the UV spectral intensity distributions in, and chemical species contributing to the emission from, Shuttle glow and rocket engine plumes.

Spartan 204 science objectives are sponsored by the U.S. Naval Research Laboratory (NRL), Washington, DC. The FUVIS science investigation team consists of Principal Investigator Dr. George Carruthers of NRL, and Co- Investigators Dr. Adolf Witt, University of Toledo, Dr. Reginald Dufour, Rice University, and Dr. John Raymond, Center for Astrophysics.

SPARTAN Operations

Attached Operations

The science payload is mounted aboard the Spartan carrier. When the Shuttle is on orbit and the payload bay doors are open, a crew member uses the robot arm to lift Spartan from the payload bay. The instrument on the Spartan carrier is controlled over a command path through the robot arm while a crew member points the spacecraft on the end of the arm using the robot arm's controls. Several pointing sequences will be performed over one and a half orbits. After this part of the science mission is over, tracking control system tests will be performed using the spacecraft on the end of the robot arm before the spacecraft is berthed.

Free-flight Deployment

After the Mir rendezvous portion of the mission is complete, a crew member will again use the robot arm to lift the Spartan spacecraft from the payload bay, and this time will release it over the side of the Shuttle. It will be deployed from the Shuttle so that it can operate independently and leave the Orbiter free for other activities. Because the Spartan and Shuttle become separated, the Spartan will be able to view the celestial targets clear of any contamination which might be generated by Shuttle thruster firings.

After initialization, Spartan is designed to operate autonomously. During the free-flight, the Shuttle crew has no interaction with the satellite other than deploying and retrieving it.

For approximately 40 hours, Spartan 204's instrument will observe various celestial targets of interest as the Space Shuttle paces it from behind. About four hours prior to the scheduled retrieval, the Shuttle will perform engine firings allowing it to close on Spartan 204, eventually passing directly below it before a crew member manually flies the final few hundred feet (approximately 100 meters) to allow the satellite to be grasped by the robot arm. Once caught by the arm, Spartan 204 will be brought back into the cargo bay.

Detailed Test Objectives (DTOs)

Besides its scientific mission, the Spartan 204 spacecraft will support two Space Station Detailed Test Objectives, or DTOs. For the first DTO, Spartan 204 has six laser retroreflectors mounted on it to aid in testing the Tracking Control System (TCS). They will be used during proximity operations after the attached operations on Flight Day 2, as well as during deployment and retrieval on flight days 5 and 7.

For the second DTO, the Spartan 204 spacecraft will be used as a large mass handling object by the EVA crew members. They will demonstrate the ability to move large objects without the robot arm, using new equipment and techniques.

During their EVA, the astronauts will practice moving Spartan 204 around the payload bay after its science mission is complete, on Flight Day 7. The Spartan 204 spacecraft has mounted on it three EVA handling attachment points to aid the crew in controlling the spacecraft. After the mass-handling portion of the EVA, the astronauts will put the Spartan spacecraft back onto its support structure for the remainder of the mission.

SPARTAN 204 STATISTICS

Launch Vehicle:	Space Shuttle Discovery (STS-63)
Deployment Altitude:	Approximately 190 nautical miles
Inclination:	51.6 degrees
Spacecraft Weight:	2,661 lbs. (1,210 kg)

SPARTAN 204 MANAGEMENT

The Spartan-204 mission is sponsored by the Air Force Space Test Program. The FUVIS is the primary scientific instrument on the Spartan-204. The FUVIS experiment is sponsored, designed and constructed at the Naval Research Laboratory, Washington, DC.

The Spartan project is managed by GSFC for the Office of Space Science, Washington, DC. The acting Spartan Project Manager is Dave Shrewsbury, and the Goddard Space Flight Center Mission Manager is Mark Steiner. GSFC provides the Spartan carrier and manages its integration with the Shuttle.

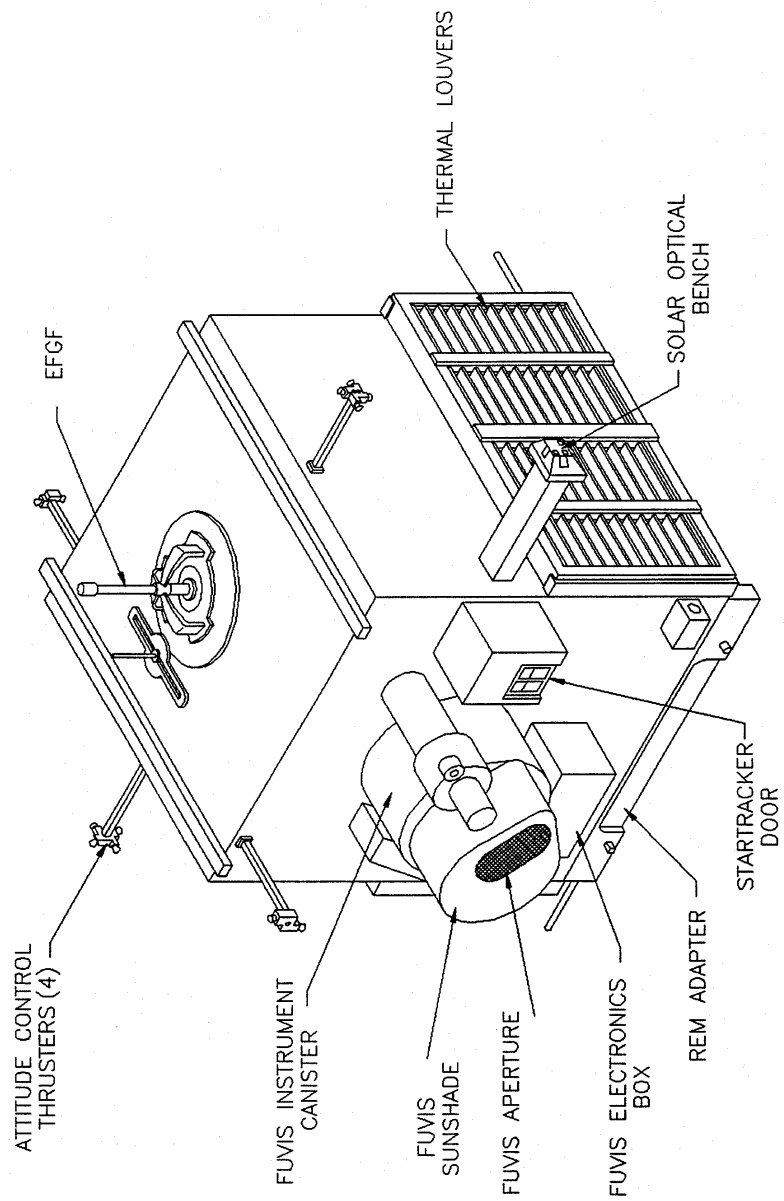

SPARTAN 204 SPACECRAFT

SPARTAN 204
DEPLOYABLE
SPACECRAFT

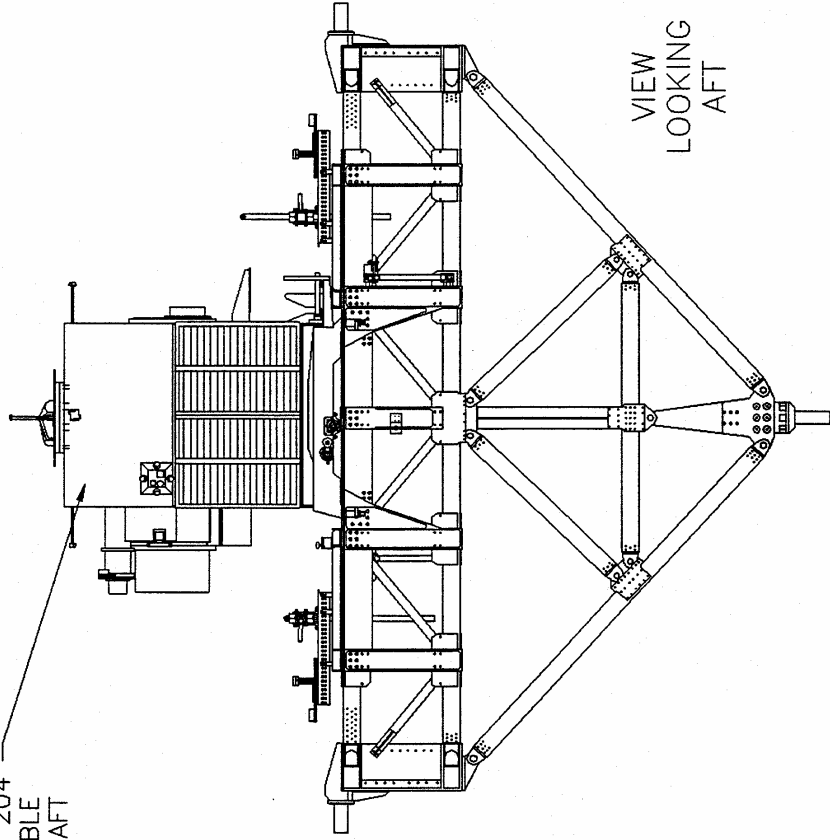

VIEW
LOOKING
AFT

STS-63 HITCHHIKER PROGRAM/PAYLOAD OVERVIEW

The Hitchhiker Program, managed by the Shuttle Small Payloads Project at GSFC, is designed for customers who wish to fly quick-reaction and low-cost experiments on the Shuttle. The program's system is designed to be modular and expandable in accordance with customer requirements. The system provides power, data or command services to operate these experiments. Typically, payloads receive their power and data handling through the Hitchhiker Avionics which provides standardized electrical, telemetry, and command interfaces between the Orbiter and the experiments. During the mission operations, experimenters will receive real-time communications between themselves and their payloads at the Payload Operations Control Center (POCC) located at GSFC.

The first of four Hitchhiker missions manifested for 1995 is CGP/ODERACS-II. The payload's acronym stems from the following experiments: Cryo System Experiment (CSE), Shuttle Glow (GLO-2) experiment and the Orbital Debris Radar Calibration System-II (ODERACS-II) experiment. An IMAX Camera also is flying in this configuration. The Hitchhiker carrier used to support the CGP/ODERACS-II experiments is a crossbay carrier referred to as a Mission Peculiar Equipment Support Structure (MPESS). Displays of orbit position, attitude, ancillary data, and any downlink data will allow the experimenters to monitor the status of their payloads during the mission.

Experiment: Cryo System Experiment (CSE)

Customer: Jet Propulsion Laboratory (JPL) and Hughes Aircraft Corporation

Principal Investigator: Russell Sugimura (JPL), Sam Russo (Hughes)

Mission Manager: Susan Olden, Hitchhiker Program, GSFC

The Cryo System Experiment (CSE) is a space flight experiment conducted by the Hughes Aircraft Co., in a cooperative program with NASA. The overall goal of the CSE is to validate and characterize the on-orbit performance of two thermal management technologies that comprise a hybrid cryogenic system. These thermal management technologies consist of: 1) a new generation, long life, low vibration, 65 K Stirling-cycle cryocooler, and 2) an oxygen diode heat pipe that thermally couples the cryocooler and a cryogenic thermal energy storage device. The experiment is necessary to provide a high confidence zero-gravity database for the design of future cryogenic systems for NASA and military space flight applications.

These technologies promise to satisfy many of the currently defined system performance goals for planned NASA and military space programs. Feasibility of each technology has already been demonstrated in independent R&D ground based laboratory tests. However, questions raised by the scientific community relative to the performance of these components in a zero-gravity environment must be answered before these technologies can be optimized for application to flight systems. The CSE flight experiment is configured to: 1) provide data necessary to resolve performance and design issues, 2) validate capability of the hybrid cooling system to meet future mission requirements, and 3) provide for the high confidence and the design of flight system concepts currently being considered.

During on-orbit operation, test data will be recorded to characterize performance of the technology including 1) oxygen diode heat pipe temperature gradient and transport capacity in steady-state and transient conditions, 2) system vibration levels attributed to the active cryocooler, and 3) integrated, extended operations of the cooling system.

An understanding of the performance of these components in flight is required to develop accurate performance models for designing flight hardware. Key issues to be addressed include: 1) heat pipe transfer capacity and start up behavior, 2) cryocooler mechanical disturbance and cryocooler dynamic balance.

Ground-based life testing of the cryocooler has been initiated at Hughes in support of the experiment and will continue into next year for comparison with flight data.

The flight experiment results will be significant to a number of satellites scheduled for deployment in the late 1990s, for which cryocooler technologies are contemplated, including those in support of NASA's Mission to Planet Earth and Astrophysics Programs.

The Cryo System Experiment illustrates an important type of NASA in-space flight experiment in which a relatively mature system technology is validated to provide the option for subsequent application for future space system development. A successful experiment could be followed by the use of the technology in an operational system.

Experiment: Shuttle Glow Experiment (GLO-2)

Customer: University of Arizona and USAF/Phillips Laboratory

Principal Investigator: Dr. Lyle Broadfoot (Univ. of AZ), Dr. Edmond Murad (Phillips Lab)

Mission Manager: Susan Olden, Hitchhiker Program, GSFC

This experiment originated as the Shuttle Glow experiment sponsored by the USAF/Phillips Laboratory. The nature of the instrument makes it ideal for studies of Earth's thermosphere. Consequently, it has become a joint program with NASA/Space Physics Division of the Office of Space Science.

The GLO-2 will investigate the mysterious shroud of luminosity, called the "glow phenomenon," observed by astronauts on past Shuttle missions. Theory suggests that the glow may be due to atmospheric gases collisionally interacting on the windward or ram side surface of the Shuttle with gaseous engine effluents and contaminant outgassing molecules.

To understand why spacecraft glow, and the potential effects of glow on space-based sensors, USAF Phillips Laboratory is sponsoring the experiment to collect spectral and imaging data to characterize the optical emissions. The principal investigators, Dr. Edmond Murad from the Phillips Laboratory and Dr. Lyle Broadfoot from the University of Arizona, plan to collect high resolution (0.5 nanometer) spectra over a wide spectral range including the ultraviolet and visible portions of the spectrum. The spatial extent of the glow will be mapped precisely (0.1 degrees), and the effects of ambient magnetic field, orbit altitude, mission elapsed time, Shuttle thruster firings, and surface composition on the intensity and spectrum of the glow will be measured. An optical emission model will then be developed from the data.

The GLO-2 experiment consists of imagers and spectrographs, which are bore-sighted to the imagers, so that both sensors are focused onto the same area of observation, for example, the Shuttle tail. The imagers serve to unambiguously identify the source region of the glow spectrum as well as to map the spatial extent of the luminosity. Unique features of the sensors are their high spectral and spatial resolution. Each spectrograph employs a concave holographic grating that focuses and disperses light within a small field of view (0.1 by 2.0 degrees) over the wavelength range of 115-1100 nanometers. The sensor comprises nine separate channels, each of which operates simultaneously and independently, to cover individual segments of the spectrum. Spectrally resolved light from the grating is amplified by image intensifiers that are optically coupled to a charge-coupled-device (CCD) detector. CCD-pixel readouts are summed in groups to achieve spatial mapping with a resolution of about 0.1 degrees.

The imager comprises six separate telescopes, of which four are intensified. Images are conducted to the single CCD by fiber optics. One image channel is wide angle, and one has high magnification. The other four channels are filtered to different wavelength bands. The spectrographs and imagers are mounted on a scan platform, which rotates about the vertical and horizontal axes, and provides sensor scanning in azimuth and elevation over glowing Shuttle surfaces. Experiment hardware units include the sensor head, a scan platform, electronics, and high- and low- voltage power supplies.

The Shuttle glow experiments are short in duration compared to the total flight time of the mission, therefore, the remainder of the flight is dedicated to studies of Earth's atmosphere. This phase of the experiment is called the Arizona Airglow Experiment. The scientific objectives are related to the ionosphere, thermosphere and mesosphere section of the NASA Space Physics Division. A scientific team will receive

the data, assist in planning the experiments, and coordinate the overflights with ground-based sites or networks. The period of the flight is identified in the scientific community as a campaign. Active participants who have ground-based instrumentation will attempt to make observations throughout the campaign. The data are correlated and deposited in a data bank at the National Center for Atmospheric Research, Boulder, CO, for use by the community. The coordination of this data is important to relate local observation to the global picture provided by the GLO observations from the Shuttle.

An accurate description of the process leading to the emissions from the sunlit thermosphere is being pursued by the GLO experiment. The two prominent ion emissions are **the [OII] (7320) and the N2+ (1N)** systems. Presently, both emissions have shortcomings as reliable signatures of the ionosphere conditions. The nature of the nitrogen ion N2+ (1N) emission in the twilight and dayglow has still not been fully explained. The intensity of the emission is greater, by about a factor of two, than models predict. The nature of the emission is further confused since neither the extended rotational nor vibrational distributions are understood. Earlier data sets have not had the quality to resolve these problems. Investigators believe that the GLO data will provide more insight.

The nature of the mesospheric reactions in the night atmosphere have eluded proper investigation. The ability of the GLO experiment to observe all of the night sky emission simultaneously has already demonstrated its usefulness. The GLO observation from a previous mission demonstrated that vertical profiles through the emitting layer are easily obtained and will add markedly to understanding of these mesospheric processes.

An important task for the GLO experiment is concerned with atmospheric model validation. Atmospheric models typically predict vertical profiles of reaction products which give rise to emissions. The models do not account for the manifold of energy distribution within systems but, rather, predict the total product in excited states. Establishing the relationship of the total production to the observation is the responsibility of the experiment and the spectral analyst. The relationship of the model to the observation is the responsibility of the theorist. Again, collaboration is the most powerful tool; each party contributes its expertise to a single problem.

A graduate student program will provide the interface between the model and the experiment. The modeler will be involved in the planning to optimize his/her validation. The observation will be advocated by the graduate student and the data product will be prepared and defended by the graduate student using the spectral analysis capabilities at the GLO data center at the University of Arizona.

In the next few years the GLO experimenters, USAF/Phillips Lab and the University of Arizona representatives, will be changing research practices because the overall objective is to understand the nature of our atmosphere on a global basis. Global models are already well underway, but the hope of verifying those models on a global scale is unrealistic. Our nearest approach to the global verification will come through coordinated observational opportunities. No one type of experiment, orbit or ground-based observation is a sufficient test. Our closest approach will be through coordinated studies, ground stations, rocket and satellite coordination.

Experiment: IMAX Cargo Bay Camera (ICBC)

Customer: Johnson Space Center

Payload Manger: Dick Walter

Mission Manager: Susan Olden, Hitchhiker Program, GSFC

The IMAX Cargo Bay Camera is a space-qualified, 65 mm color motion picture camera system that consists of a camera, lens assembly, and a film supply magazine containing approximately 3500 feet of film and an empty take-up magazine. The camera is housed in an insulated, pressurized enclosure with a movable lens window cover. The optical center line of the 60 mm camera lens is fixed and points directly out of the payload bay along the Orbiter Z axis with a 15 degree rotation towards the Orbiter nose. Heaters and

thermal blankets provide proper thermal conditioning for the camera electronics, camera window, and film magazines.

The 65 mm photography will be transferred to 70 mm motion picture film for playing in IMAX theaters. An audio tape recorder with microphones will be used in the crew compartment to record middeck audio sounds and crew comments during camera operations. The audio sound is then transferred to audio tapes or compact discs for playing in coordination with the IMAX motion picture.

The camera system is operated by the crew from the Aft Flight Deck with the enhanced Get Away Special Autonomous Payload Controller (GAPC). Commands such as on/off, camera standby, and camera run/stop may be initiated by the crew. Additional commands for camera setups such as f/stop, focus, and frame rate status of exposed film footage also are accomplished by the crew using the GAPC. A light level measurement unit will be used by the crew to set the lens aperture. Four focus zones and seven aperture settings are available for this flight.

The normal camera speed is 24 frames per second (fps). On this flight, this also can be changed to 3 fps for photographing slower moving objects. The 3500 feet of film in the ICBC will last approximately 10.5 minutes at 24 fps and much longer at 3 fps. Film cannot be changed in flight and ICBC operations are terminated when all film is exposed. ICBC is managed by Dick Walter of the Johnson Space Center.

Experiment: Orbital Debris Radar Calibration System-II (ODERACS-II)

Customer: Johnson Space Center

Principal Investigator: Gene Stansbery

Mission Manager: Susan Olden, Hitchhiker Program, GSFC

Man-made debris, now circulating in a multitude of orbits about the Earth as a result of the exploration and use of space, poses a growing hazard to future space operations. Since the launch of Sputnik 1, more than 3200 launches have placed about 6500 artificial orbiting objects, weighing 2 million kilograms (4.4 million pounds) in orbit around the Earth. While these objects are cataloged by the Space Surveillance Network operated by United States Space Command (USSPACECOM), only six percent represent functional satellites; the rest are considered debris. Additionally, USSPACECOM tracks only objects larger than 10 cm in diameter. However, history has proven that smaller objects cause considerable damage to spacecraft. Hence, orbital debris is a critical factor in the shielding design and mission planning of the International Space Station.

For the past decade, the Johnson Space Center has led efforts, such as using the Haystack Radar, to characterize the debris environment for sizes smaller than 10 cm. The Orbital Debris Radar Calibration System (ODERACS) provides a vehicle whereby small calibration targets are placed in Low Earth Orbit (LEO) for the purpose of calibrating ground-based radar and optical systems so that they may more accurately provide information regarding small debris in LEO.

Radar facilities include: the Millstone, Haystack, and the Haystack Auxiliary Radars in Massachusetts; the Kwajalein Radars (TRADEX, ALCOR, Millimeter Wave, and ALTAIR) in the South Pacific; the Eglin Radar in Florida; the PARCS Radar in North Dakota; and the FGAN Radar in Germany. Optical facilities include: the worldwide GEODDS telescope network, the NASA/JSC telescope, and the Super-RADOT telescope facility in the South Pacific. Other USSPACECOM sensor facilities also will support the mission as necessary. This experiment enables the correlation of controlled empirical optical and radar debris signatures of targets whose physical dimensions, compositions, reflectivity, and electromagnetic scattering properties are precisely known, thereby verifying or improving the sensors' accuracy and ultimately leading to better knowledge of the debris environment.

The ODERACS-II experiment, whose Principal Investigator is Gene Stansbery of Johnson, will release six targets, three spheres and three dipoles of different sizes from the Shuttle payload bay. The targets will be

observed, tracked and recorded using ground-based radar and optical sensors. The spheres are composed of polished, blackened, and whitened stainless steel and aluminum. The sphere group consists of one 2-inch diameter stainless steel sphere, one 4-inch diameter aluminum sphere and one 6-inch diameter aluminum sphere. The dipoles consist of platinum alloys chosen to maximize orbital lifetime. The dipole group consists of one 1.740 inches x .040 inch diameter wire and two 5.255 inches x .040 inch diameter wires. The targets will be ejected retrograde along the Shuttle velocity vector at velocities between 1.4 and 3.4 meters per second (4.5 to 11.1 feet per second). The estimated average orbital lifetime of the targets ranges from about 20 to 280 days and is highly dependent on solar flux and the resultant atmospheric heating. All targets will completely burn up during reentry.

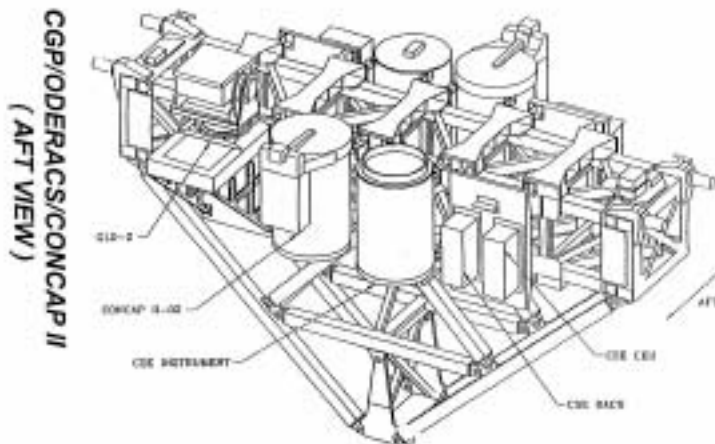
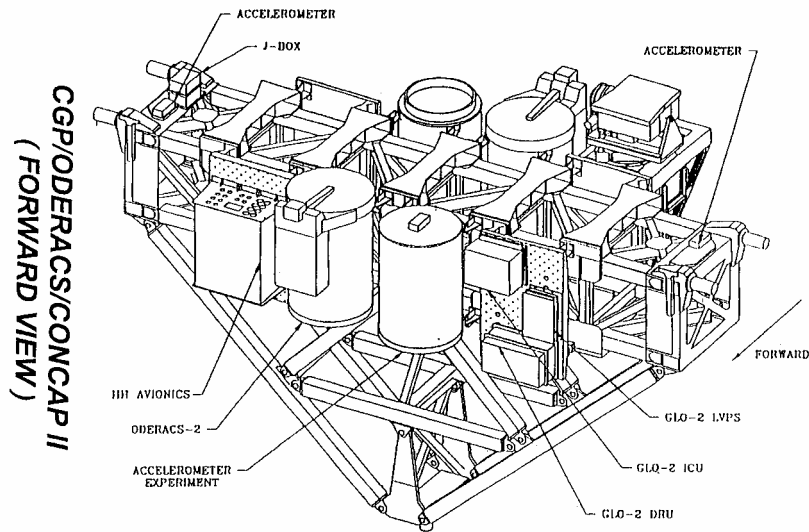

STS-63 EVA ACTIVITIES

STS-63 will continue laying the groundwork for future space activities on the flight's seventh day when Mission Specialists Mike Foale and Bernard Harris perform an almost five-hour spacewalk to test spacesuit modifications and practice handling large objects in microgravity.

During the extravehicular activity, Foale will carry the designation EV1 and will be wearing red stripes on the legs of his spacesuit, while Harris will be EV2. Pilot Eileen Collins will assist the spacewalkers from inside the crew cabin by monitoring their progress through the EVA timeline and will serve as the primary communicator between the spacewalkers and the crew inside Discovery. Russian Mission Specialist Vladimir Titov will operate the robot arm during the spacewalk and will assist Harris and Foale into their suits.

The spacewalk has two specific objectives: to evaluate modifications to the spacesuits that provide astronauts with better thermal protection from cold and to perform several mass handling exercises in a series of activities designed to increase NASA's experience base as it prepares for the on-orbit assembly of the International Space Station.

Past EVA experience has demonstrated that, even with the spacesuit's thermal controls, a spacewalking astronaut can become chilled when working in open or shaded areas. During most Shuttle EVAs, crew members work in the payload bay where the Orbiter's radiated heat keeps the spacewalkers warm. The assembly of the International Space Station, however, will require astronauts to work in extremely cold conditions frequently.

Several modifications have been made to the spacesuit systems to prevent astronauts' hands from becoming cold. On the liquid cooling garment, for example, the cooling tubes running down the arms have been bypassed so the spacewalkers' arms are not cooled. Additional layers of material have been added to the thermal undergarment and the exterior of the suit's gloves for warmth.

The evaluation of the modifications will be performed when Discovery is positioned with its belly pointed toward the Sun and the payload bay shadowed, creating the coldest environment possible. The robot arm, with Foale and Harris on it, will be extended above the payload bay, clear of the Orbiter's radiated heat. Foale and Harris will stay in that position without performing any work for about 15 minutes, all the time providing ground engineers with objective feedback and data on their thermal comfort levels.

The mass handling exercises will be performed with the Spartan spacecraft, which will have been returned to the payload bay only a few minutes before start of the EVA. The exercise will begin with Foale in a Portable Foot Restraint on the end of the robot arm and Harris in a restraint on the Spartan's support structure.

Titov will move Foale into position to grab Spartan from its berthing platform. Foale will then hand the satellite to Harris who will perform a series of translation and rotation maneuvers. When he is finished, Harris will hand the satellite back to Foale, who will repeat the activity on the end of the robot arm.

The entire EVA is scheduled for 4 hours, 50 minutes, but may be shortened if the Spartan retrieval is delayed.

SPACEHAB-3

The primary payload for the STS-63 mission is SPACEHAB-3, a pressurized, commercially-developed space research laboratory located in the forward end of Discovery's cargo bay. The laboratory is accessed by crew members from the Orbiter's middeck through a tunnel adapter connected to the vehicle's airlock. This is the third flight of SPACEHAB-- the first two highly-successful missions were flown in June, 1993, and February, 1994, aboard STS-57 and STS-60, respectively.

Under a contract awarded in 1990 with SPACEHAB, Inc., of Arlington, VA, NASA is leasing space aboard SPACEHAB-3 to support the Agency's commercial development of space program by providing access to space to test, demonstrate or evaluate techniques or processes in the environment of space and thereby reduce operational risks to a level appropriate for commercial development. The 5-1/2 ton space module significantly increases the pressurized working and storage volume normally available aboard the Shuttle.

New System Features

As a result of experience gained on SPACEHAB-1 and -2, it is clear that there are some resources the SPACEHAB shares with the Space Shuttle that are very scarce. One of those resources is crew time. SPACEHAB, Inc., has developed two new system features to significantly reduce the demands on crew time. The first new feature is a video switch to reduce the demand for crew time in video operations, and the second new feature is an experiment interface to the SPACEHAB telemetry system to reduce the demand for crew time in experiment data down link.

The SPACEHAB video system uses camcorders that are tied to the Orbiter closed circuit television system and then down linked through the Orbiter. On SPACEHAB-1 and -2, the crew set up the camcorders and manually switched from one camera scene to another, a time-consuming operational arrangement. For SPACEHAB-3, SPACEHAB, Inc., installed a video switching unit allowing up to eight camcorders to be cabled into the SPACEHAB video switch. Then, by ground control, one of the camcorders can be switched into the Orbiter system for down link. Also, another one of the camcorders can collect a digital image on a freeze frame and send it down through SPACEHAB's telemetry stream, independent of other Orbiter video down link operations. This new video switch and digital television down link capability will provide operational flexibility that will be very valuable on this flight and on subsequent flights.

SPACEHAB, Inc., also has enhanced the experiment data interface with the SPACEHAB telemetry system in the interest of on-orbit efficiency. The system now allows an experimenter with a standard RS232 computer interface to tie directly into the system and send continuous information down to the ground, off loading this task from the crew and enhancing ground controller monitoring of experiment status.

Also, on the roof of the SPACEHAB laboratory there will be two 12-inch diameter windows installed for STS-63. One window will have a NASA docking camera in it to assist in the Mir proximity operations.

Experiments

Over 20 SPACEHAB-3 experiments, sponsored by NASA's Offices of Space Access and Technology and Life and Microgravity Sciences and Applications together with the Department of Defense, represent a diverse cross-section of technological, biological and other scientific disciplines and were developed for flight by an equally-diverse complement of university, industry and government organizations nationwide. A summary of experiments to be flown aboard STS-63 follows:

The ASTROCULTURE™ payload is sponsored by the Wisconsin Center for Space Automation and Robotics (WCSAR), a NASA Center for the Commercial Development of Space (CCDS), located at the University of Wisconsin at Madison.

Extended space ventures that involve human presence will require safe and reliable life support at a reasonable cost. Plants play a vital role in the life support system present here on Earth. Likewise, it can be expected that plants will be a critically important part of a life support system in space because they can be a source of food while also providing a means of purifying air and water. Currently, no satisfactory plant-growing unit is available to support long-term plant growth in space. Several industry affiliates including Automated Agriculture Assoc., Inc., Dodgeville, WI; Quantum Devices, Inc., Barneveld, WI; and Orbital Technologies Corp., Madison, WI; together with WCSAR have been involved with this cooperative program to develop the technologies needed for growing plants in a space environment.

The objective of the ASC series of flights is to validate the performance of plant growth technologies in the microgravity environment of space. Each of the flight experiments involves the incremental addition of important subsystems required to provide the necessary environmental control for plant growth. The flight hardware is based on commercially-available components thereby significantly reducing the hardware costs. The information from these flight experiments will become the basis for developing large scale plant-growing units required in a life support system. In addition, these technologies also will have extensive uses on Earth, such as improved dehumidification/humidification units, water-efficient irrigation systems, removal of hydrocarbons and other pollutants from indoor air and energy-efficient lighting systems for plant growth.

The ASC-1 flight experiment, conducted during the USML- 1 mission on STS-50, evaluated the WCSAR concept for providing water and nutrients to plants.

The ASC-2 flight experiment, conducted during the SPACEHAB-1 mission on STS-57, provided additional data on the water nutrient delivery concept, plus an evaluation of the light-emitting diode-based plant lighting concept. The ASC-3 flight experiment, included in the SPACEHAB-2 STS-60 mission, provided data for a concept to control temperature and humidity in a closed-plant growth chamber. Results from these flight experiments confirmed the validity of these concepts for use in a space-based growing unit.

The ASTROCULTURE™ ASC-4 flight experiment aboard the STS-63 mission will be the first to include plants. Wheat seedlings and special fast-growing plants developed at the University of Wisconsin-Madison College of Agriculture and Life Sciences will be used to confirm the performance of the ASC environmental control subsystems. Also being evaluated is the Zeponics nutrient composition control system developed by researchers at NASA's Johnson Space Center, Houston.

Demonstration of successful plant growth in space using the ASTROCULTURE™ unit will represent a major advance in the ability to provide superior environmental control for plant growth in an inexpensive and reliable flight package.

A supplemental experiment is being conducted in cooperation with researchers at NASA's Ames Research Center, CA. This experiment is referred to as the Fluid Dynamics in a Porous Matrix (FDPM) experiment and consists of three test units being flown as stowage. This experiment will investigate capillary migration of liquids in granular beds. This knowledge is essential for the optimization of a substrate-based nutrient and water delivery system for plant growth in space.

The flight hardware for this mission is accommodated in a SPACEHAB locker located in the module, and weighs approximately 50-pounds. The ASC-4 flight unit includes humidity and temperature control, lighting, water and nutrient delivery, nutrient composition control, CO2 control, atmospheric contaminant removal, video and data acquisition. These subsystems provide essentially all the environmental regulation needed for plant growth. The next ASC flight experiment beyond SPACEHAB-3 will be a 16-day experiment on STS-73 to study plant starch metabolism and carbohydrate translocation in potato leaves.

Principal Investigator on ASTROCULTURE™ is Dr. Raymond J. Bula, WCSAR.

BioServe Pilot Laboratory-3 (BPL-3)

The BioServe Pilot Laboratory-3 payload is sponsored by BioServe Space Technologies, a NASA Center for the Commercial Development of Space (CCDS) based at the University of Colorado, Boulder, CO, and Kansas State University, Manhattan, KS.

BioServe developed the BPL to provide a “first step” opportunity to companies interested in exploring low-gravity research in a wide variety of life sciences areas with primary emphasis on cellular studies. For STS-63, two series of investigations will be carried out on bacterial products and processes.

BioServe will examine *Rhizobium trifolii* behavior in microgravity. Rhizobia are special bacteria that form a symbiotic relationship with plants. The bacteria infect the plants early in seedling development to form nodules on the plant roots. The bacteria in these nodules derive nutritional support from the plant while, in turn, providing the plant with nitrogen fixed from the air. Plants that form such relationships with rhizobia are called legumes and include alfalfa, clover and soybean. Such plants do not require synthetic fertilizers to grow. In contrast, many important crop plants such as wheat and corn are dependent on synthetic fertilizers since they do not form symbiotic relationships with rhizobia. Understanding the multi-step process associated with rhizobia infection of legumes may make it possible to manipulate the process to cause infection of other crop plants. The potential savings in fertilizer production would be tremendous.

Another BioServe investigation concerns the bacteria *E. Coli*. These bacteria are normally found in the gastrointestinal tracts of mammals, including man. *E. Coli* have been thoroughly studied as a model system for bacterial infection, population dynamics and genetics research. *E. Coli* has been manipulated to produce bacteria capable of secreting important pharmaceutical products and also has served as a model for bacteria used in waste treatment and water reclamation.

BioServe will study these bacteria to determine changes in growth and behavior that occur as a consequence of exposure to microgravity. The commercial objectives include understanding and controlling bacterial infection in closed environments; exploiting bacteria and other microorganisms in the development of ecological life support systems and waste management; determining the opportunity for enhanced genetic engineering; and enhanced pharmaceutical production using bacterial systems. For STS-63, the BPL will consist of 40 Bioprocessing Modules (BPMs) stowed in a standard locker in the middeck of Discovery. The BPMs will contain the biological sample materials. The stowage locker also will contain an Ambient Temperature Recorder which will provide a temperature history of the payload throughout the mission.

For most of the investigations, simultaneous ground controls will be run. Using similar hardware and identical sample fluids, ground personnel will activate and terminate BPMs in parallel with the flight crew. Synchronization will be accomplished based on voice downlink from the crew. Ground controls will be conducted at the SPACEHAB Payload Processing Facility at Cape Canaveral, FL.

After the Orbiter has landed, the stowage locker containing the BPMs will be turned over to BioServe personnel for de-integration. Some sample processing will be performed at the landing site. However, most BPMs will be shipped or hand-carried back to the sponsoring labs for detailed analysis.

Dr. George Morgenthaler, Director of the BioServe CCDS, is Program Manager. Dr. Louis Stodieck and Keith Pharris, also of BioServe, are responsible for mission management.

Biological Research in Canisters (BRIC-3)

Research on carbohydrate-rich plants is the subject of the Biological Research in Canisters payload.

Soybeans and other carbohydrate-rich plants would provide an ideal food source for long-duration space missions, including Space Station. This experiment will investigate the basic processes involved in

carbohydrate production by observing how exposure to microgravity affects the production of consumable food products.

In this research, soybean seeds are rolled in germination paper and placed in tubes located inside BRIC canisters. The experiment will be sealed and housed in the middeck of the Space Shuttle. The experiment itself is passive, however, the crew is required on mission day five to transfer one canister to the freezer. Freezing these samples will dramatically increase the science return for this investigation by allowing an examination of plants developed in microgravity to be contrasted with control groups developed in regular gravity.

The experiment will be removed immediately after landing in order to freeze the second canister's soybean seedlings before the effects of gravity are re-established.

BRIC experiments are sponsored by NASA's Office of Life and Microgravity Sciences and Applications and managed by NASA's Kennedy Space Center, FL. Dr. Christopher Brown, Plant Space Biology Program, Kennedy Space Center, is Principal Investigator.

Commercial Generic Bioprocessing Apparatus (CGBA-6)

The Commercial Generic Bioprocessing Apparatus-6 payload is sponsored by BioServe Space Technologies, a NASA Center for the Commercial Development of Space (CCDS), located at the University of Colorado, Boulder, and Kansas State University, Manhattan, KS. The purpose of the CGBA is to allow a wide variety of sophisticated biomaterials, life sciences and biotechnology investigations to be performed in one payload in the low gravity environment of space.

Corporate affiliates include the Center for Cancer Research, Manhattan, KS; Kansas Agricultural Experiment Station, Manhattan, KS; NeXagen, Boulder, CO; Synchrocell, Inc.; and Water Technology Industries.

During the STS-63 mission, BioServe will support 26 separate commercial investigations which can be classified in three application areas: biomedical testing and drug development; small agricultural and environmental systems development; and biomaterials and biotechnology systems development.

In the Biomedical Testing and Drug Development category, eight biomedical models will be tested in microgravity. Of the eight models, three are related to immune disorders: one will study the ability of macrophage cells to function normally; one will study the ability of T- lymphocyte cells to secrete essential communication modules; and one will study the ability of immune system cells to respond to infectious-type materials. The other five models are related to bone and developmental disorders, wound healing, cancer and cellular disorders. Analysis of the test results will provide information to better understand diseases and disorders that affect human health, including cancer, osteoporosis and AIDS. In the future, these models may be used for the development and testing of new drugs to treat these diseases.

In the category of Small Agricultural and Environmental Systems Development, BioServe will conduct seven ecological studies: five on seed germination and seedling processes; one on brine shrimp; and one on a new material's ability to control build-up of unwanted bacteria and other microorganisms.

In the third category, Biomaterials and Biotechnology Systems Development, BioServe will investigate eleven different biomaterials and biotechnology products and processes in the following areas: large protein and RNA crystals for use in commercial drug development; assembly of virus shells for use in a commercially-developed drug delivery system; enzymatic breakdown of fibrin, collagen and cellulose materials with application to engineering of tissue implants; bacterial systems with application to understanding proliferation, antibiotic resistance, pharmaceutical production and response to environmental

stress; and evaluation of the use of microscopic magnetic particles, called magnetosomes, to form strong, collagen-based materials for possible use in artificial implants.

Some experiments will require astronaut involvement while others will be automated. For most investigations, simultaneous ground controls will be run in synchronization with flight crew participation.

After Discovery has landed, the stowage lockers will be retrieved and turned over to BioServe personnel for de-integration. Some sample processing will be performed at the SPACEHAB Payload Processing Facility in Florida, but most will be shipped or hand-carried back to the sponsoring laboratories for detailed analysis.

Dr. George Morgenthaler, Director of the BioServe CCDS, is Program Manager for CGBA. Dr. Louis Stodieck and Keith Pharris, also of BioServe, are responsible for mission management.

CHARLOTTE

An experimental robotic device built by McDonnell Douglas Aerospace (MDA) will fly aboard the SPACEHAB module to demonstrate automated servicing of experimental payloads and allow remote video observation aboard the pressurized space research laboratory.

Through the compact device, roughly the size of a small microwave oven, investigators hope to demonstrate the advantages of a simple, safe, low power, rigid, easily-installed robotic device to relieve the workload of future flight crews.

Nicknamed "Charlotte" by its MDA developers, this robot does not employ gantries, jointed-arms or complicated systems. Charlotte, when deployed by the STS-63 crew, will be suspended on cables which are relatively easy to install and remove.

Among Charlotte's experimental objectives are to operate knobs, switches and buttons inside the SPACEHAB module. The robot also has the capability to changeout experimental samples and data cartridges and perform many other inspection and manipulation tasks thereby automating many routine procedures and freeing the flight crew to perform other tasks.

CHROMEX-6

In previous spaceflight experiments, it has been observed that plants exposed to microgravity exhibit abnormalities in cell shape and structure. Many of these observations can be linked to changes in the plant cell walls. These cell walls of plants determine many aspects of plant growth, including shape, growth rate, cell-cell recognition, and composition of fiber to name a few. Many of the biochemical features that characterize mature, functional cell walls are catalyzed by cell wall-associated enzymes. The CHROMEX-6 study will help explain the role of these enzymes in establishing normal cell wall structure and function.

The species being studied is Superdwarf Wheat (*Triticum aestivum*) which will be planted 48 hours prior to flight. These plants will develop under laboratory conditions until specimens are loaded for flight. The plants will be loaded into the Orbiter during the late load timeframe. Upon return to Earth, the plants will be dissected, fixed by exposure to cryogenics, and analyzed for cell wall associated enzymes. CHROMEX-5, which flew on STS-68, examined the effects of space flight on early reproductive events in plants and was the first occurrence of successful pollination, fertilization and embryo development (formation of young seed) for a U.S. investigator. A longer-duration flight opportunity will be necessary in order to produce mature seed from seed that is planted in space.

Earlier attempts at successful plant reproduction in space flight (CHROMEX-3 and 4) may have failed because of poor airflow or replacement in the chambers housing the plants in the Plant Growth Unit (PGU)

and/or insufficient CO₂ availability to the plants due perhaps to the microgravity environment lacking connective air movement. CHROMEX-5 employed the new active Air Exchange System (AES) for the PGU for the first time to enhance air circulation to and around the plants. And the CHROMEX-5 plants are being analyzed for increased carbohydrate levels and other evidence of improved growth and development.

The experiment is sponsored by NASA's Office of Life and Microgravity Sciences and Applications and managed by NASA's Kennedy Space Center, FL. Dr. Elizabeth E. Hood, Utah State University, is Principal Investigator.

Commercial Protein Crystal Growth (CPCG)

The Commercial Protein Crystal Growth (CPCG) experiments aboard STS-63 are sponsored by the Center for Macromolecular Crystallography (CMC), based at the University of Alabama at Birmingham. The CMC is a NASA Center for the Commercial Development of Space (CCDS) which forms a bridge between NASA and private industry by developing methods for the crystallization of macromolecules in microgravity. These crystals are used to determine the three-dimensional structure of the molecules by X-Ray crystallography. The structural information not only provides a greater understanding of the functions of macromolecules in living organisms, but it also provides scientific insight into the development of new drugs.

By the technique of protein crystallography, crystals of purified proteins are grown in the laboratory, and X-Ray diffraction data are collected on these crystals. The three-dimensional structure is then determined by analysis of this data. Unfortunately, crystals grown in the gravity environment of Earth frequently have internal defects that make such analysis difficult or impossible. Space-grown crystals often have fewer defects and are much better than their Earth-grown counterparts.

The protein crystal growth experiments aboard STS-63 will consist of two crystallization systems: the Vapor Diffusion Apparatus (VDA) and the Protein Crystallization Facility (PCF).

The objective of the VDA experiments aboard STS-63 is to use the microgravity environment to produce large, well-ordered crystals that yield X-Ray diffraction data that are superior to the data from their Earth-grown counterparts. This will be the 18th flight of the Vapor Diffusion Apparatus experiments, and the series of experiments has produced the highest-quality crystals ever grown of several proteins. Crystallographic analysis has revealed that on average 20% of proteins grown in space in the VDA are superior to their Earth-grown counterparts.

The objective of the PCF experiment, contained in a thermal control enclosure located in the middeck, will be to crystallize human alpha interferon protein. Alpha interferon is a protein pharmaceutical that currently is used against human viral hepatitis B and C. The objective is to discover the next generation alpha interferon pharmaceuticals and formulations.

With continued research, the commercial applications developed using protein crystal growth have phenomenal potential, and the number of proteins that need study exceeds tens of thousands. Current research, with the aid of pharmaceutical companies, may lead to a whole new generation of drugs that could help treat diseases such as cancer, rheumatoid arthritis, periodontal disease, influenza, septic shock, emphysema, aging and AIDS.

A number of pharmaceutical companies partner with the CMC including: BioCryst Pharmaceuticals, Inc; Eli Lilly and Co.; Schering-Plough; DuPont Merck Pharmaceuticals; Eastman Kodak; Upjohn Co.; Smith Kline Beecham Pharmaceuticals; and Vertex Pharmaceuticals, Inc. Principal Investigator for the STS-63 protein crystal growth experiments is Dr. Larry DeLucas, Director of the CMC.

Equipment for Controlled Liquid Phase Sintering Experiments (ECLIPSE)

The Consortium for Materials Development in Space (CMDS), based at the University of Alabama in Huntsville (UAH) has developed the Equipment for Controlled Liquid Phase Sintering Experiments (ECLIPSE). This furnace was developed in a very rapid and cost-effective manner. Development of ECLIPSE was supported by Wyle Laboratories. It successfully flew on the first two SPACEHAB missions and is now available as space-qualified hardware and is a key part of the nation's commercial space infrastructure.

The SPACEHAB-3 ECLIPSE experiment will investigate the "Liquid Phase Sintering" (LPS) of metallic systems. "Sintering" is a well-characterized process by which metallic powders are consolidated into a metal at temperatures only 50% of that required to melt all of the constituent phases. In LPS on Earth, a liquid coexists with the solid which can produce sedimentation, thus producing materials that lack homogeneity and dimensional stability. To control sedimentation effects, manufacturers limit the volume of the liquid. The ECLIPSE experiment examines metallic composites at or above the liquid volume limit to understand more fully the processes taking place and to produce materials that are dimensionally stable and homogeneous in the absence of gravity. The concept of "defect trapping in microgravity" will be pursued during this experiment. The knowledge gained from the experiments will be applied toward preventing or controlling defect formation.

This flight of the ECLIPSE payload is building on the experience of other ECLIPSE flights on sub-orbital rockets. Sub-orbital flights have provided 1-3 minutes of sample processing time. Longer flight durations are made possible by the Shuttle. The STS-63 flight will be the longest melt period (approximately one hour) for the copper series. Copper is the metal that melts and provides the liquid phase in the sintering process.

Composites of hard metals in a tough metal matrix have excellent wearing properties of the hard material and the strength of the touch material. Applications of such a composite include stronger, lighter, more durable metals for bearings, cutting tools, electric brushes, contact point and irregularly-shaped mechanical parts for high stress environments.

Industry partners on the ECLIPSE experiment, besides Wyle Laboratories, are Kennametal, Inc.; Automatic Switch Co.; Parker Hannifin Corp.; and Machined Ceramics. Principal Investigator for ECLIPSE is Dr. James E. Smith Jr., Associate Professor and Chairman, Department of Chemical and Materials Engineering at UAH.

Fluids Generic Bioprocessing Apparatus-1 (FGBA-1)

The Fluids Generic Processing Apparatus-1 is the first of three commercial payloads being developed by BioServe Space Technologies. BioServe is a NASA Center for the Commercial Development of Space (CCDS) located at the University of Colorado, Boulder. A consortium of private businesses, universities and government, including The Coca-Cola Company, Atlanta, GA; Martin Marietta, Denver, CO; Ohmeda, Boulder, CO; University of Colorado, Boulder; Kansas State University, Manhattan, KS; and NASA's Office of Space Access and Technology, Washington, DC, have combined resources to sponsor the FGBA commercial program.

The consortium has a major long-range objective in advancing fluid management technology in microgravity. Consistent with this objective, this first BioServe FGBA experiment represents a significant opportunity to obtain fundamental data on containment, manipulation and transfer of pressurized, supersaturated two-phase fluids. During STS-63, this program is expected to further the commercial objectives of The Coca-Cola Company in developing both terrestrial and space applications. The Coca-Cola Company has a strong interest in developing hardware to carbonate water on demand and to mix and dispense beverages with minimal loss of carbonation. Developing technology to accomplish these objectives in microgravity may

likely evolve into terrestrial applications that could further the long-range research and development objectives of The Coca-Cola Company.

This flight will provide baseline data on changes in astronauts' taste perception of beverages consumed in microgravity. The beverages to be used in the evaluation are Coca-Cola and diet Coke. The taste perception changes experienced by astronauts on-orbit will be compared to their taste perception of these beverages in matched pre- and post-flight ground controls involving the same crew members.

Dr. George Morgenthaler, Director of the BioServe CCDS, is Program Manager for the FGBA experiment. Drs. Louis Stodieck and Alex Hoehn, also of BioServe, are responsible for mission management. Dr. Ashis Gupta is the principal engineer for this experiment for The Coca-Cola Company.

Gas Permeable Polymer Materials (GPPM)

The Gas Permeable Polymer Materials (GPPM) payload is sponsored by NASA Langley Research Center, Hampton, VA, and its commercial affiliate, Paragon Vision Sciences of Phoenix, AZ.

Plastic materials, which are made of very large molecules called "polymers", are used in everyday life in many ways. Some polymers prevent gases, such as oxygen, from passing through. These polymers are used in keeping foods fresh for long periods of time in a refrigerator or freezer. Other polymers allow one or more gases to pass through. These polymers, called gas permeable polymeric materials, also have many uses. Gravity may affect many properties of the polymer while it is being made. As early as 1984, it was suggested that these effects may be eliminated or at least reduced if the polymer were made in the low gravity of space flight.

The Gas Permeable Polymer Materials (GPPM) flight experiment is a follow on to the first GPPM flight, which took place in July 1993. The purpose of these flights is to determine if certain types of polymers made in low gravity while the Space Shuttle is in orbit, differ greatly from the same polymers made at the same time on the ground. The current flight will evaluate new materials based on results from the first GPPM flight.

This second flight also will determine if polymers can be made from monomers which cannot be mixed on the ground. As in the first GPPM mission, there also will be ground experiment samples tested to compare the results of the polymer manufacturing process in a gravity-based setting.

Gas permeable polymeric materials have many uses. One use is the potential improvement in contact lenses for long-term wear, allowing greater oxygen to pass through the lens and adding comfort to the wearer. Paragon Vision Sciences is a leading manufacturer of polymers for contact lenses, and is using these flight activities to determine if formation of polymers in microgravity has application to their line of optical products.

There are other potential applications of polymers developed in microgravity, including medical applications such as dialysis and blood gas monitoring, and industrial processes associated with the manufacture of pure gases. Langley researchers are interested in further exploring other uses for polymer materials developed in low gravity.

After the return of the samples from the STS-63 mission, Paragon Vision Sciences and NASA researchers will assess the mission results and make the determination on what the next steps will be. Langley researchers will use the results from the flight to determine what might be possible new research paths to take using polymer development in microgravity.

Handheld Diffusion Test Cell (HH-DTC)

The Handheld Diffusion Test Cell (HH-DTC) apparatus will evaluate experiment chambers designed for the new Observable Protein Crystal Growth Apparatus (OPCGA), which will use sophisticated optical techniques to analyze the growth of individual crystals in orbit. Scientists have been growing protein crystals in space for almost a decade. There is good evidence that in about 25 percent of the cases crystals can be grown in space that are superior to any grown on Earth. Determining exactly why some space-grown crystals are better is the goal of the Observable Crystal Growth System and the transparent test cells being tested on this flight. If scientists can pinpoint the underlying mechanisms which influence growth in space versus that on Earth, the fundamental knowledge they gain could suggest improved methods of crystal growth in orbit as well as in Earth-based laboratories. Past studies on small-molecule crystal growth, for instance involving semiconductors and laser optics, have produced such improved methods.

The STS-63 experiment also will evaluate the growth of protein crystals by diffusion of one liquid into another, since crystals produced by the liquid diffusion process will be better suited for observation experiments on upcoming flights.

The majority of previous Shuttle protein crystal growth experiments have involved growth by vapor diffusion, concentrating a droplet by evaporation to force the remaining material to crystallize. However, planned OPCGA observations cannot be done with the round droplets found in vapor diffusion.

In liquid-liquid diffusion, different fluids are brought into contact but not mixed. Over time, the fluids will diffuse into each other through random motion of molecules. The gradual increase in concentration of the precipitant within the protein solution causes the proteins to crystallize. Liquid-liquid diffusion is difficult on Earth because differences in solution densities allow mixing by gravity-driven thermal convection. In addition, the greater density of the crystals allows them to settle into inappropriate parts of the cell.

Four HH-DTC units containing four test cells each will be flown, for a total of 16 test cells. The end of the test cells where crystals will grow and the containment housing are made of clear plastic, so the crew can photograph growth during the mission. Three HH-DTC units will be housed in Spacehab lockers, and the other will be mounted on the Spacehab module wall for periodic video recording.

Each test cell has three chambers: protein solution, buffer solution, and precipitant solution. The buffer solution chamber cuts across the width of a shaft between protein and precipitant solutions. Before the experiment, a valve is positioned so each fluid is isolated from the others. An astronaut will activate the experiment by rotating the valve 90 degrees, so the buffer contacts the protein and precipitant and the three form a single volume. The rotating valve minimizes liquid movement, limiting alteration of the liquids' shapes and volumes. When the three liquids are in contact, they will slowly diffuse into each other. The crew will close the valves before return to Earth.

Candidate proteins for growth in the HH-DTC include several which have been crystallized in previous Shuttle experiments to allow comparisons of results from the different growth methods. The proteins include lysozyme, hemoglobin, satellite tobacco mosaic virus, concanavalin B and concanavalin. Dr. Alexander McPherson Jr., of the University of California, Riverside, is Principal Investigator for HH-DTC.

Immune System Experiment - 2 (IMMUNE-2)

The IMMUNE-2 experiment is a commercial middeck payload sponsored by BioServe Space Technologies. BioServe is a NASA Center for the Commercial Development of Space at the University of Colorado, Boulder, and Kansas State University, Manhattan. The corporate affiliate leading the IMMUNE-2 investigation is Chiron Corporation, Emeryville, CA. NASA's Ames Research Center, Mountain View, CA, provides payload and mission integration support.

The goal of IMMUNE-2 is to further understand and define the ability of Polyethylene Glycol-Interleukin-2 (PEG-IL2) to prevent or reduce the detrimental effects of space flight on immune responses in rats.

This is a follow-on experiment to IMMUNE-1, which showed that PEG-IL2 did induce a trend toward a reduction in space flight-caused changes in immune responses. These experiments may result in greater understanding of immunodeficiencies in general. In particular, they may lead to development of new therapeutic approaches for dealing with the effects of space flight on the human immune system and on physiological systems affected by the immune system.

Hardware for the IMMUNE-2 experiment consists of two suitcase-size Animal Enclosure Modules (AEMs) in the Shuttle's middeck area. Ames Research Center developed the AEMs to support NASA's space life sciences research program. The AEMs provide a safe habitat and all life support functions for rats during a Space Shuttle mission. AEMs have had a very successful flight history, with 13 flights in support of other NASA investigations. IMMUNE-2 is the sixth experiment to use the AEM in support of activities to develop the commercial uses of space.

Each of the two AEMs will hold six white male rats. Six of the rats will be treated pre-flight with a prescribed dosage of a compound similar to the commercially available recombinant Interleukin-2 (IL-2). IL-2 is known to stimulate the immune system. The compound, PEG-IL2, is longer-lasting than recombinant Interleukin-2. Scientists hope it will reduce or prevent the suppression of the immune system seen in rats flown in space. The other six rats will receive a placebo.

The rats will live in an environment similar to that of the astronauts in terms of launch stress, length of exposure to microgravity, and the forces of Shuttle re-entry and recovery. These conditions are known to result in a suppression of the immune system similar to "shipping fever" in cattle. The utility of PEG-IL2 in preventing space flight-induced effects on the immune system may lead to its use as a therapeutic treatment for shipping fever in animals on Earth.

The longer-lasting PEG-IL2 probably will be useful in clinical settings as well. It might reduce the frequency of injections required, to perhaps once a week instead of up to three times a day, as is necessary with recombinant IL-2. The development of recombinant IL-2 for treatment of some human cancers is still being investigated, although it is licensed for high-dose therapy of kidney cancer in humans.

Based on recent experimental findings, PEG-IL2 (and recombinant IL-2) appears to have potential as an immunoregulatory agent leading to control of microbial infections. As such, PEG-IL2 may become part of a therapy used to treat various opportunistic infections associated with AIDS and other non-AIDS related infectious diseases.

It also may become useful for the nation's aging population, because aging individuals show decreased levels of Interleukin-2. The PEG-IL2 treatment could accompany flu shots to bolster the immune system of the elderly. These important applications present exciting commercial opportunities for Chiron Corp.

Dr. Robert Zimmerman, of the Chiron Corp., Emeryville, CA, is Principal Investigator for the IMMUNE-2 experiment.

National Institutes of Health C-3

The NIH-C-3 payload is composed of three collaborative biomedical experiments sponsored by NASA and the National Institutes of Health (NIH). These three experiments will make use of a computerized tissue culture incubator known as the Space Tissue Loss (STL) Culture Module. STL was developed at the Walter Reed Army Medical Center in Washington, DC, to study cells under microgravity.

These three experiments are sponsored by NASA's Office of Life and Microgravity Sciences and Applications and the National Institute of Arthritis and Musculoskeletal and Skin Diseases:

1. Effects of Hypogravity on Osteoblast Differentiation (Animal and Human Physiology: Bone loss)

Principal Investigator: Dr. Ruth Globus, Department of Medicine
University of California at San Francisco

Several U.S. Shuttle flights and the Russian Cosmos biosatellite series of space flights showed that weightlessness causes bone loss in rats and humans, apparently because of abnormal functions of the bone-forming cells called osteoblasts. The investigators do not yet know whether the reduced gravitational environment experienced by astronauts in space directly harms osteoblast function, or alternatively, whether changes in hormones or other systemic factors lead to the bone loss.

The investigators will test the hypothesis that exposure to space flight causes abnormal function of bone-forming osteoblasts grown in culture, even though those cells are isolated from systemic influences. An experiment using isolated rat osteoblasts flown on the Shuttle (STS 59) in the STL previously showed that space flight might directly impair both the energy metabolism and the mature function of isolated osteoblasts. Comparable changes in the activity of astronaut's osteoblasts during space flight may contribute to their loss of bone mass.

Investigators will confirm and extend previous results; they will determine whether space flight regulates specific genes which are needed for normal osteoblast function.

They also will evaluate the quality of bone-like tissue formed by the cultured osteoblasts during space flight. They expect information gathered from this experiment to contribute substantially to the understanding of how gravity regulates bone cell function, a basic question that remains largely unanswered.

2. Molecular and Cellular Analysis of Space Flown Myoblasts (Animal and Human Physiology: Muscle loss)

Principal Investigator: Dr. David A. Kulesh, Capt., USAF
Armed Forces Institute of Pathology, Washington, DC

While many of the overt physiological effects of microgravity can be compensated for by various countermeasures, effects at the cellular and molecular levels may require other means of intervention. However, little detail is known about the direct effect of microgravity at the molecular and cellular level. Insight into the cellular and molecular events responsible for muscle cell growth and development come in large part from in-vitro studies with established cell lines. This investigation will use a well-characterized rat skeletal muscle cell line, in the STL module. The specific goals of the muscle cell culture model are to augment the whole animal model studies and simplify the molecular and cellular analysis of microgravity effects on muscle tissue in general.

For Dr. Kulesh's research, rat muscle cells will be cultured in individual cell cartridges and sustained in the STL module. The experiment itself is passive, requiring no in-flight manipulation except for temperature monitoring. The experiment requires special preparations before launch and immediate removal from the Shuttle after landing, to access the effects of microgravity on the growth of muscle cells, before the effects of full gravity are re-established.

Post flight experiments with the space flown muscle cells will evaluate the overall effect of microgravity on cellular characteristics (shape, doubling times, etc.). In addition, the investigator will begin to assess possible changes in the expression of proteins and genes after their exposure to microgravity.

Gravity may play an integral role in the biological functioning of single cells. Information on the effects of gravity on muscle cell development will help scientists overcome the deleterious effects of space travel.

These studies in weightlessness will also contribute to the understanding of cell proliferation, cell differentiation, development and wound healing.

3. Influence of Space Flight on Bone Cell Cultures (Animal and Human Physiology: Bone loss)

Principal Investigator: Dr. William J. Landis
Children's Hospital Boston, MA

In humans and other vertebrates, the weightless environment of space flight causes defective skeletal growth, marked by a loss of bone mass and a change toward lower bone maturity. The development of defective bone is believed to involve matrix production controlled by bone cells, bone mineralization, or an interaction between bone matrix production and bone mineralization.

The investigators will use established cell lines of chicken osteoblasts in the STL module. The investigators will analyze rates of cell growth, aspects of collagen and bone development, and mineralization both inside and outside the cultured cells. Data obtained in the flight experiments should provide knowledge on the effects of gravity on osteoblast activity and function, protein development, and mineralization. The studies will have implications for long duration space flight, as well as application to the diagnosis and treatment of prolonged skeletal immobilization or mineral abnormalities.

Protein Crystallization Apparatus for Microgravity

The Protein Crystallization Apparatus for Microgravity (PCAM), to be carried in the Shuttle middeck, tests a new design for growing large quantities of protein crystals in orbit. The apparatus holds more than six times as many samples as are normally accommodated in the same amount of space.

Proteins are important, complex biochemicals that serve a variety of purposes in living organisms. Determining their molecular structures will lead to a greater understanding of how those organisms function. Knowledge of the structures also can assist the pharmaceutical industry in the development of disease-fighting drugs.

Many proteins can be grown as crystals and their molecular structure determined through analysis of the crystals by X-Ray crystallography. Unfortunately, crystals grown in the gravity environment of Earth often have internal defects that make such analysis difficult or impossible. As demonstrated on Space Shuttle missions since 1985, some protein crystals grown in space are larger and have fewer defects.

The PCAM will grow crystals using the vapor diffusion method, which has been highly effective in previous Shuttle experiments. In vapor diffusion, liquid evaporates from a protein solution and is absorbed by a reservoir solution contained in a wicking material. As the protein concentration rises, the proteins form crystals.

A controlled-temperature enclosure occupying a single Shuttle mid-deck locker, called the Single-locker Thermal Enclosure System (STES), will hold six cylinders containing a total of 378 samples – one of the largest quantities in any single protein crystal growth experiment to date. In previous experiments of this type, a single locker accommodated a maximum of 60 samples. The STES will maintain temperatures at 72 degrees Fahrenheit (22 degrees Celsius).

Each cylinder contains nine trays held in position by guide rods and separated from each other by bumper plates with springs. The trays are sealed by an adhesive elastomer. Each tray holds seven sample wells, surrounded by a donut-shaped reservoir with a wicking material to absorb the protein carrier solution as it evaporates.

To start the experiment, an astronaut will open the front of the thermal enclosure, then rotate a shaft on the end of the cylinder with a ratchet from an Orbiter tool kit. This will allow diffusion to start and protein crystal growth to begin. Near the end of the mission, an astronaut will rotate the shaft in the opposite direction to stop diffusion.

A few of the candidate proteins for this flight of the PCAM are human cytomegalovirus assembling (a factor in virus duplication), parathyroid hormone antagonist (a controlling factor in bone growth), pseudoknot 26 (a potential HIV inhibitor), and human antithrombin III (a blood clotting factor).

Dr. Daniel Carter of NASA's Marshall Space Flight Center, Huntsville, AL, is Principal Investigator for PCAM.

Space Acceleration Measurement System (SAMS)

STS-63 will be the 13th mission SAMS has supported and will be the third on a Spacehab mission. For this mission, SAMS will be flying in the mid-deck instead of the Spacehab module as it has in the past. SAMS will be supporting three different protein crystal experiments (PCG-STES, CPCG-VDA and PCF-LST). These experiments require late access for launch which can only be accommodated in the mid-deck of the Space Shuttle. Each of these experiments will have a dedicated 10 Hz triaxial sensor head (TSH) to monitor its particular vibration environment. Shortly before activation, the crew will mount the three TSHs at their designated locations close to the experiments.

SAMS will provide the scientists conducting these experiments with the information of the microgravity environment they experienced during the mission. The scientists will be able to account for the rocket thruster firings, crew activity and background vibrations that influence these delicate experiments. The instrument is managed by NASA's Lewis Research Center, Cleveland, OH, for the agency's Office of Life and Microgravity Sciences and Applications, Washington, DC.

Three-Dimensional Microgravity Accelerometer (3-DMA)

The Consortium for Materials in Space (CMDS) is sponsoring the Three Dimensional Microgravity Accelerometer on the STS-63 mission. The CMDS is a NASA Center for the Commercial Development of Space (CCDS) based at the University of Alabama in Huntsville (UAH).

The acceleration measurement experiment system will help chart the effects of deviations from zero-gravity on experiments conducted in space. The microgravity environment inside the SPACEHAB Space Research Laboratory will be measured in the three dimensions by the 3-DMA at four different locations, allowing researchers to review experiment results against deviations from zero-gravity. This information will be used to determine the degree of microgravity achieved inside the SPACEHAB.

The 3-DMA will measure disturbances caused by operating various experiments in SPACEHAB and the residual microgravity resulting from Orbiter rotational motions and by residual resistance at the upper atmosphere fringes. No crew interaction is required on-orbit other than occasional status checks. Status data also are sent to the ground by telemetry.

The 3-DMA, which successfully flew aboard the first two SPACEHAB missions, has been developed as a low-cost system suitable for commercialization by the CMDS.

A potential application of 3-DMA would be to characterize potential microgravity environment of the International Space Station in support of experiments, research and commercialization activities.

Principal Investigator for 3-DMA is Jan Bijvoet of the UAH CCDS.

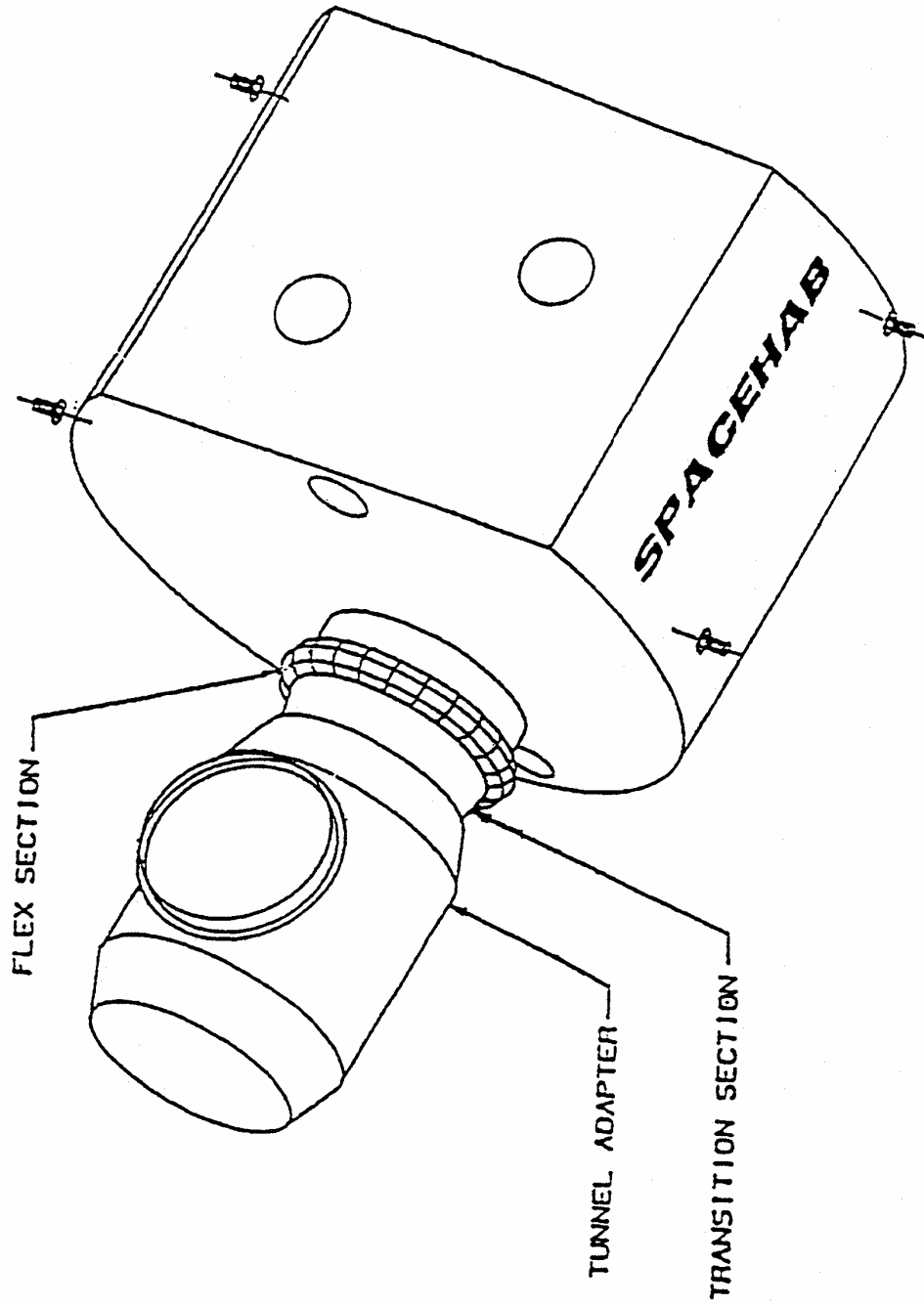

SPACEHAB - 3

SPACEHAB 03 EXPERIMENT OVERVIEW

SH-03 EXPERIMENT LAYOUT SPACEHAB 03 MODULE LAYOUT

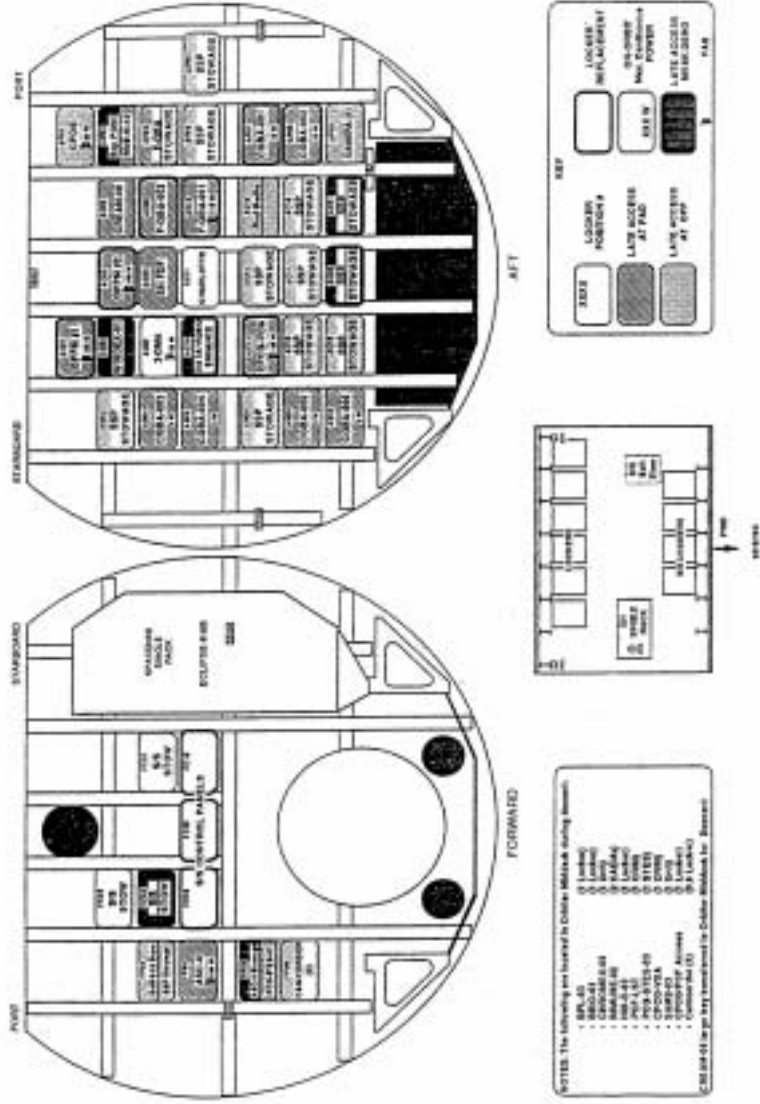

SOLID SURFACE COMBUSTION EXPERIMENT

Principal Investigator: Robert A. Altenkirch, Dean of Engineering, Mississippi State University

The Solid Surface Combustion Experiment (SSCE) is a major study of how flames spread in a microgravity environment. Comparing data on how flames spread in microgravity with knowledge of how flames spread on Earth may contribute to improvements in all types of fire safety and control equipment. This will be the eighth time SSCE has flown aboard the Shuttle, testing the combustion of different materials under different atmospheric conditions. The experiment hardware is flown in the Shuttle mid-deck in place of the four middeck stowage lockers.

In the SSCE test planned for STS-63, scientists will investigate flame spread along a sample of Plexiglas in an environment of 50% oxygen and 50% nitrogen at 1 atmosphere pressure. This flight will be the third test with the Plexiglas fuel. The previous tests were performed on STS-54 with an environment of 70% oxygen and 30% nitrogen at 1 atmosphere and STS-64 with an environment of 50% oxygen and 50% nitrogen at 2 atmospheres.

Scientists will use computer image enhancement techniques to analyze the film record of the Solid Surface Combustion Experiment. They will then compare the enhanced images and recorded temperature and pressure data with a computer simulation of the flame spreading process. Reconciliation of data and predictions is expected to provide new insights into the basic process of combustion of solid surfaces. The data from the previous missions are still being analyzed but have already provided insights into the combustion process and improvements to the combustion model that the principal investigators have developed.

The experiment is sponsored by NASA's Office of Life and Microgravity Sciences and Applications and managed by NASA's Lewis Research Center, Cleveland, OH.

AIR FORCE MAUI OPTICAL SITE (AMOS)

The Air Force Maui Optical System (AMOS) is an electrical-optical facility on the Hawaiian island of Maui. No hardware is required aboard Discovery to support the experimental observations. The AMOS facility tracks the Orbiter as it flies over the area and records signatures from thruster firings, water dumps or the phenomena of "Shuttle glow," a well-documented fluorescent effect created as the Shuttle interacts with atomic oxygen in Earth orbit. The information obtained by AMOS is used to calibrate the infrared and optical sensors at the facility. AMOS is a Department of Defense payload and is flown under the direction of the DOD Space Test Program.

STS-63 CREWMEMBERS



STS063-S-002 -- With the United States and Russian flags in the background, five NASA astronauts and a Russian cosmonaut named to fly aboard the Space Shuttle Discovery for the STS-63 mission pose for the flight crew portrait at JSC. Left to right (front row) are Janice E. Voss, mission specialist, Eileen M. Collins, pilot; James D. Wetherbee, mission commander; and Vladimir Titov of the Russian Space Agency, mission specialist. In the rear are Bernard A. Harris Jr., payload commander; and C. Michael Foale, mission specialist.

No copyright is asserted for this photograph. If a recognizable person appears in the photo, use for commercial purposes may infringe a right of privacy or publicity. It may not be used to state or imply the endorsement by NASA or by any NASA employee of a commercial product, process or service, or used in any other manner that might mislead. Accordingly, it is requested that if this photograph is used in advertising and other commercial promotion, layout and copy be submitted to NASA prior to release.

PHOTO CREDIT: NASA or National Aeronautics and Space Administration.

BIOGRAPHICAL DATA

JAMES (JIM) D. WETHERBEE, 42, Commander, USN, will be the Commander (CDR) of STS-63. Wetherbee was born in Flushing, NY, and will be making his third space flight.

Wetherbee graduated from Holy Family Diocesan High School in South Huntington, NY, in 1970; received a bachelor of science degree in aerospace engineering from the University of Notre Dame in 1974; and completed training at the U.S. Naval Test Pilot School in Patuxent River, MD, in 1981.

His first Shuttle flight was as pilot of Columbia during STS-32, a mission that successfully deployed the Syncom IV-F5 satellite and retrieved the Long Duration Exposure Facility. He next flew as commander of STS-52, a mission that deployed the Laser Geodynamic Satellite and operated the first U.S. Microgravity Payload.

Wetherbee has logged more than 497 hours in space and more than 4,200 hours flying time and 345 carrier landings in 20 different types of aircraft.

EILEEN M. COLLINS, 38, Lt. Col., USAF, will serve as Pilot (PLT). Born in Elmira, NY, Collins was selected as an astronaut in 1990. She will be making her first space flight, becoming the first woman to pilot a Space Shuttle.

Collins graduated from Elmira Free Academy, Elmira, NY, in 1974; received an associate of science degree in mathematics/science from Corning Community College in 1976; a bachelor of arts degree in mathematics and economics from Syracuse University in 1978; a master of science degree in operations research from Stanford University in 1986; and a master of arts degree in space systems management from Webster University in 1989. She is a 1990 graduate of the Air Force Test Pilot School.

She served as a T-38 instructor pilot and C-141 aircraft commander and instructor pilot. Collins has logged more than 4,000 hours in 30 different types of aircraft.

BERNARD A. HARRIS JR., 38, will be Payload Commander, Mission Specialist 1 (MS1) and Extravehicular Crewman 2 (EV2) on STS-63. Harris was born in Temple, TX, and will be making his second space flight.

Harris graduated from Sam Houston High School, San Antonio, TX, in 1974; received a bachelor of science degree in biology from the University of Houston in 1978; and a doctorate in medicine from Texas Tech University School of Medicine in 1982. After completing residency training in internal medicine at the Mayo Clinic, Harris conducted research in the field of musculoskeletal physiology and disuse osteoporosis under a Research Council Fellowship at the Ames Research Center, Moffett Field, CA.

Harris' first Shuttle flight was as a mission specialist on board Columbia during STS-55 in 1993. That mission saw a variety of research done in physical and life sciences. Harris has logged over 239 hours in space.

BIOGRAPHICAL DATA

C. MICHAEL (MIKE) FOALE, 38, will be Mission Specialist 2 (MS2) and Extravehicular Crewman 1 (EV1) on STS-63. Selected as an astronaut in 1987, Foale was born in Louth, England, but considers Cambridge, England, to be his hometown. Foale will be making his third space flight.

Foale graduated from Kings School, Canterbury, in 1975; received a bachelor of arts degree in physics, National Science Tripos, with first class honors from Queens College in 1978; and a doctorate in laboratory astrophysics from Cambridge University in 1982.

Foale's first flight was as a mission specialist on STS-45 in March and April, 1992, a mission that saw the first of the ATLAS flights to study the atmosphere and its interaction with the Sun. He also flew as a mission specialist on STS-56, carrying the ATLAS-2 and the SPARTAN retrievable satellite which made observations of the solar corona. Foale has logged more than 436 hours in space.

JANICE VOSS, 38, will be Mission Specialist 3 (MS3) on STS-66. Born in South Bend, IN, Voss considers Rockford, IL, her home town. She was selected as an astronaut in 1990 and will be making her second Shuttle flight.

Voss graduated from Minnechaug Regional High School, Wilbraham, MA, in 1972; received a bachelor of science degree in engineering science from Purdue University in 1975; a master of science degree in electrical engineering and a doctorate in aeronautics/astronautics from Massachusetts Institute of Technology in 1977 and 1987, respectively.

Voss' first Shuttle flight was as a mission specialist on STS-57 in June 1993. STS-57 included the retrieval of the European Retrievable Carrier (EURECA) satellite, and the first flight of the Spacehab mid-deck module. Voss has logged more than 239 hours in space.

VLADIMIR GEORGIEVICH TITOV, 48, Colonel, Russian Air Force, will be Mission Specialist 4 (MS4) on STS-63. Titov will be making his first flight on board the Space Shuttle, becoming the second cosmonaut to fly on an American spacecraft.

In October 1992, Titov was one of two Russian cosmonauts named by the Russian Space Agency for mission specialist training. Titov trained as back-up mission specialist for Sergei Krikalev, who flew on STS-60 in February 1994.

Titov graduated from the Higher Air Force College in Chernigov, Ukraine, in 1970 and the Yuri Gagarin Air Force Academy in 1987. He joined the cosmonaut team in 1976 and is a veteran of three space flights with a total of 368 days in space.

Titov served as commander on Soyuz T-8 and Soyuz T-10 in 1983 and Soyuz TM-4 in 1987. Soyuz T-8, a mission to repair a faulty Salyut 7 solar array, lasted 2 days, 17 minutes and 48 seconds when the rendezvous was aborted. Soyuz T-10 was aborted following a launch pad fire. The crew module was pulled clear of the rocket by the launch escape system and after a flight of 5 minutes, 30 seconds, landed 2.5 miles from the launch vehicle.

During his third space flight in December 1987, Titov rendezvoused with the Mir Space Station spending a record 365 days, 22 hours, 39 minutes in space.