

## **Historic, Archive Document**

Do not assume content reflects current scientific knowledge, policies, or practices.



AE 78  
A14569

Reserved

Lrd 13

101

United States  
Department of  
Agriculture

Forest  
Service

Intermountain  
Region

Ogden, Utah

Cultural Resource  
Report No. 9



# Log Cabin Studies:

- The Rocky Mountain Cabin
- Log Cabin Technology and Typology
- Log Cabin Bibliography





LOG CABIN STUDIES

By  
Mary Wilson

- The Rocky Mountain Cabin
- Log Cabin Technology and Typology
- Log Cabin Bibliography

CULTURAL RESOURCE REPORT NO. 9  
USDA Forest Service  
Intermountain Region  
Ogden, Ut  
1984

EDITORS NOTES

*The author is a cultural resource specialist for the Boise National Forest, Idaho. An earlier version of her Rocky Mountain Cabin study was submitted to the University of Idaho as an M.A. thesis.*

*Cover photo: Homestead claim of Dr. E. Watson, Fall Creek, Idaho (date unknown).*

THE ROCKY MOUNTAIN CABIN  
By  
Mary Wilson

USDA Forest Service  
Intermountain Region  
1984





## TABLE OF CONTENTS

	Page
EDITORS NOTES.....	i
ABSTRACT.....	ii
ACKNOWLEDGEMENTS.....	iii
1. INTRODUCTION.....	1
2. HISTORY OF LOG CONSTRUCTION.....	4
3. GEOGRAPHY OF THE ROCKY MOUNTAIN REGION.....	15
4. HISTORY OF THE ROCKY MOUNTAIN REGION.....	19
A. Indians and Explorers.....	19
B. The Fur Trade.....	21
C. Mining.....	24
D. Farming and Ranching.....	26
E. Transportation.....	28
F. Logging.....	30
G. The Forest Service.....	31
5. ARCHITECTURE OF THE ROCKY MOUNTAIN CABIN.....	33
6. PAST DOCUMENTATION.....	48
7. VERNACULAR THEORY.....	56
8. ORIGIN OF THE ROCKY MOUNTIAN CABIN.....	63
9. SUMMARY.....	70
NOTES.....	74
REFERENCES CITED.....	75



## LIST OF FIGURES

Figure	Page
1. Typical Rocky Mountain Cabin.....	2
2. Floorplans of Eastern American Cabin Types.....	11
3. Anglo-Western Cabin.....	13
4. Anglo-Western Cabin.....	13
5. Physiogeographic Map of the Western United States.....	16
6. Reconstruction of a House in Succase.....	35
7. Rocky Mountain Cabin with 100 Percent Gable Extension..	35
8. Rocky Mountain Cabin, Winter Floorplan.....	36
9. Rocky Mountain Cabin, Summer Floorplan.....	37
10. Simmond's Cabin, Summer Occupation.....	38
11. Simmond's Cabin.....	38
12. Miner's Cabin in Heavy Snow.....	39
13. Winter Campsite.....	39
14. Scattergram of RMC Gable Extensions.....	41
15. Wyle's Ranch, One Story Cabin.....	42
16. Frame Cabin.....	42
17. Gambrel Roof Cabin.....	44
18. Shed Roof Cabin.....	44
19. South and East Elevations, Morton Cabin.....	45
20. Nineteenth Century Homestead.....	47
21. 1902 Homestead.....	47
22. Olebo Cabin .....	49
23. Polygon of RMC Construction Dates.....	53

	Page
24. RMC Distribution Among Western National Forests.....	55
25. Scattergram of RMC Sizes, North Idaho.....	60
26. Georgia Corncrib.....	65
27. Outbuilding, Hand Mine.....	65
28. First Generation Type Dogtrot.....	66
29. Second Generation Type Dogtrot.....	66
30. Cabin with Transitional Gable Extension.....	68
31. Cabin with Transitional Gable Extension.....	68
32. Liz Creek Cabin.....	69
33. Indian Creek Guard Station.....	69
34. Brink Realty Office.....	72
35. Cabin with Enclosed Extension.....	72

## LIST OF TABLES

Table	Page
1. Notching Types Present.....	43
2. Average Cabin Sizes by Use.....	51
3. Cabin Usage, Big Creek Drainage.....	51
4. Cabin Types Present, Big Creek Drainage.....	52



## ABSTRACT

While conducting fieldwork in southern Idaho during the summer of 1980, I came upon numerous examples of a type of cabin not previously documented. This report attempts to determine how this type fits with other known cabin types, and to find its place in present theories about American vernacular architecture. By making use of extant reports, historical photos, and archeological site forms, it is apparent this cabin type can be found throughout the Rocky Mountain region. Along with other Western studies, this report attempts to show that vernacular construction patterns in the Western United States differ from those present in Eastern study areas.





## ACKNOWLEDGEMENTS

I wish to thank the National Forests of the Western United States for their cooperation in the gathering of data for this report, particularly Jerry Wylie, Intermountain Regional Archeologist. I wish to thank John Hartung for providing information and photos from his research in the Payette National Forest of Idaho. Finally, I want to recognize the University of Idaho's Laboratory of Anthropology for its assistance in the processing of graphic materials appearing in this report.



## I. INTRODUCTION

While employed as an archeologist at Boise National Forest during the summer of 1980, I became involved in a cultural resource project concerning the typological classification of log cabins. After reviewing the existing cabin literature and doing field surveys in the Forest, it became apparent that a cabin type common to southern Idaho had not previously been studied or recorded, that actually very little information about cabin construction in the United States west of Texas was available.

Log cabins in the United States have generally been described as side-gabled dwellings with doors in the front and sometimes rear walls with a fireplace centered along a gabled wall. While this description is valid for cabins in much of the eastern United States, a cabin type appearing in Idaho is, in many ways, quite different. Orientation of the structure is changed so that the gable ends of the cabin face to the front and rear. A single door is usually off-centered in the front wall of the cabin with an iron stove replacing the fireplace along a gable wall. The most distinctive feature of this cabin is the frontward extension of the gabled roof, 25 to 100 percent of the length of the cabin, which forms a covered porch or work area (Figure 1). The first aim of this project is to describe this cabin type--to define its architectural attributes along with its geographical and temporal range.

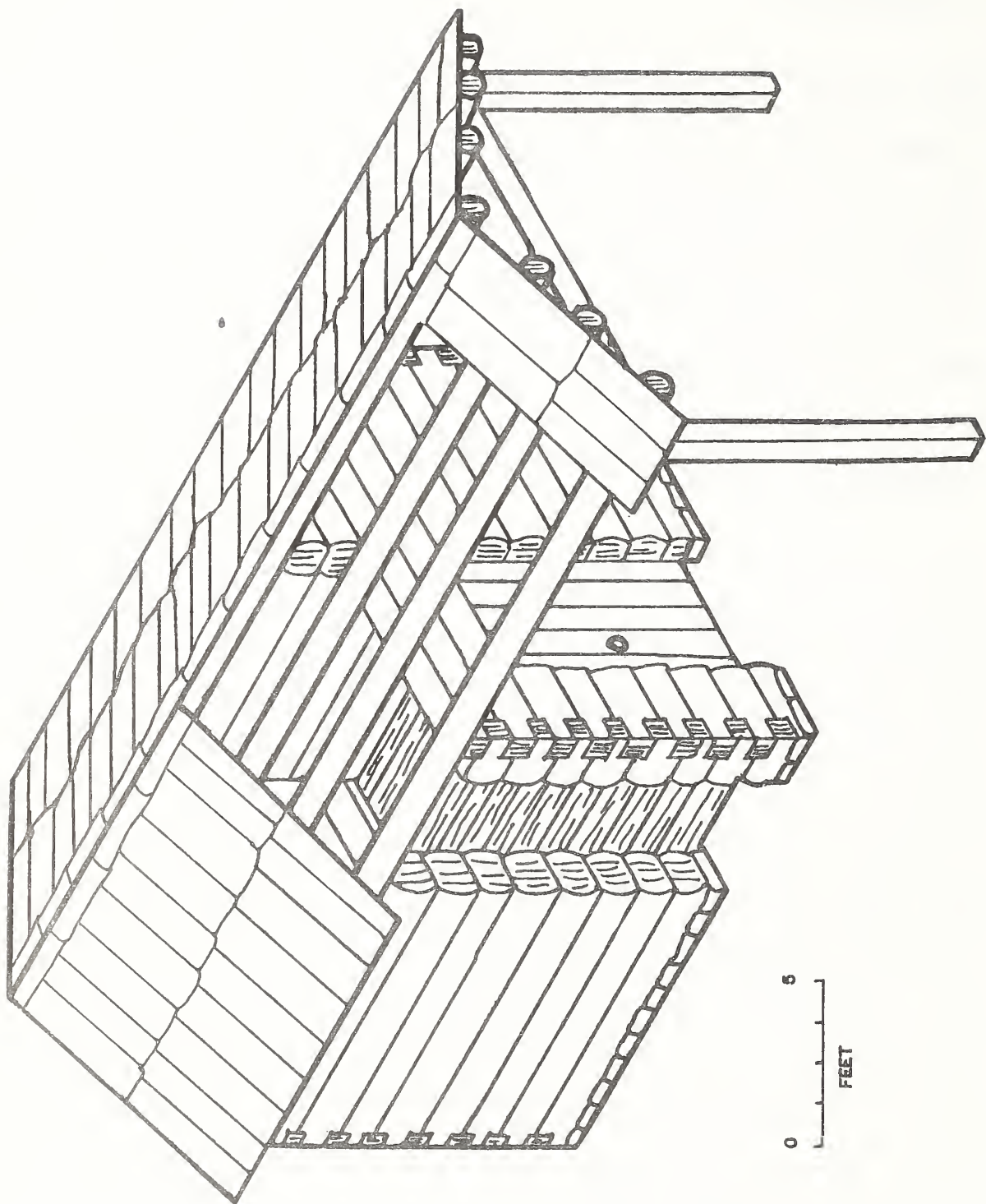

Fig. 1. Cutaway axonometric drawing of a typical Rocky Mountain Cabin.

Once described, this information becomes important when used in conjunction with other studies to make broader conclusions about human behavior. For example, in the field of vernacular architecture, the results of behavioral studies have stressed continuity and tradition over innovation. These works have included evaluations of log cabin construction, but as in the area of architecture, the studies are overwhelmingly based on Eastern examples. After an examination of settlement patterns in the Rocky Mountain Region, it becomes apparent that Western cabins differ from those of Eastern study areas, and the vernacular architecture of the Rockies reflects these differences. It is therefore the second aim of this report to determine the particular contribution of the Rocky Mountain cabin to American cabin construction and to various theories of innovation in vernacular architecture.

The data used for this report come from three primary sources: archeological site forms from the northern third of Idaho, the historical resource survey of the Big Creek Drainage in central Idaho done by John Hartung, and information on cabin types gathered from 27 National Forests in 8 Western States by the author. Photographic information was also provided from historical collections of the University of Idaho and Washington State University.

## II. HISTORY OF LOG CONSTRUCTION

The use of wood to provide shelter dates back to prehistoric times. Probably the oldest form of log housing is the use of vertical posts set close together. This practice seems to have originated in the Near East during the Neolithic and spread across Europe as a part of the Neolithic cultural complex. By Late Neolithic times, vertical post building was the dominant construction form in all of Europe except for the Far North, the Western Mediterranean, and the Atlantic coastal areas of England. Spaces left between posts were usually filled with a wattle and daub mixture (straw and small branches mixed with clay or mud). In the colder areas of the Late Neolithic, posts were set close enough together in the ground to abut each other for added insulation (Kniffen and Glassie 1966:43). Archeological examples of log construction have been unearthed at Breeze Kyawski, Biskulin, and from several other sites in the region of the bend of the Lower Vistula where traces of large rectangular houses, trapezoid in plan, have been located. These sites date from the Chalcolithic Stage, about 2000 BC (Gimbutas 1956:118).

The earliest examples of construction using horizontally laid logs held together by notched corners appear with the Magelmosian culture from Mesolithic Europe. Originally concentrated in Denmark, southern Sweden, and northern Germany, the range of this technology gradually expanded, so by the end of the Bronze age, horizontal logs had replaced vertical posts as the dominant construction form

(Kniffen and Glassie 1966:54). By the 17th century, log wall construction of rural dwellings was almost universal for most of Scandinavia, Finland, the Baltic Provinces, and Russia (Weslager 1971:85-88).

While log technology was commonly used across much of Europe, the countries responsible for much of the early colonization of the New World--France, the Netherlands, and England--did not have it as a part of their cultural inventory. It was Sweden, probably the most highly developed area in terms of log technology, that sent to North America the first log cabin builders. New Sweden was founded on Delaware Bay in 1638 by the Swedish West India Company. The site was primarily a fur trading colony of about 200 people, who were also engaged in raising cattle and cultivation (Shurtleff 1953:163-170). Swedish log construction was characterized by logs left in the round with notches cut in the top or both sides about a foot from the end, producing an overhang at the corners. Each log was grooved the entire length of its bottom so that it could fit tightly on top of the log below it (Kniffen and Glassie 1966:58).

New Sweden was annexed by New Netherlands in 1655, and then claimed by the British in 1664 following their conquest of New Netherlands. In spite of this political confusion, the Swedish colony remained culturally intact. As English settlements grew up around New Sweden, documents suggest cultural interchange took place between the groups, but English settlers continued to build their rough

structures of frame and clapboard instead of adopting the easier and stronger Swedish log construction techniques (Shurtleff 1953: 163-170). Due to their small population and the strong cultural integrity of the surrounding groups, the Swedish cabin builders had little influence on the development or diffusion of log construction techniques in North America (Weslager 1971:150-202).

The diffusion of cabin technology in America can be traced to the interaction of two different cultural groups. Beginning in 1681, the publication of Penn's Prospectus influenced many Europeans from what is now Germany and Switzerland to come to America. This diverse group, known collectively as the Pennsylvania Dutch, was far more numerous than the Swedes, exerting a stronger and wider area of cultural influence. These Germans were also log cabin builders, and brought with them housing techniques readily adaptable to this country of forests (Weslager 1971:208-215). Four different building types found in North America can be traced to definite regions of Switzerland or Germany (Shurtleff 1953:176). Pennsylvania German log work is characterized by logs notched near their end (no overhang), which produced box corner. Spaces between logs were chinked with clay, stones, poles, or shingles. The logs were usually rough or square hewn for easier handling and a more finished appearance (Kniffen and Glassie 1966:59).

The second important cultural group was the Scotch-Irish--Scotsmen who had immigrated to Ireland during the 16th and 17th centuries.



Beginning in 1717 and lasting for 50 years, five successive waves of immigration brought over 250,000 Scotch-Irish to the New World (Weslager 1971:226-235). The Scotch-Irish and Germans had much in common--similar histories of religious persecution, economic unrest, and warfare. With these similarities, they soon became politically aligned against the English (Glassie 1968:8). Being a very adaptable group, the Scotch-Irish were quick to imitate the German construction forms, finding them superior to their native frame dwellings constructed of stone or mud and covered with a thatched roof (Shurtleff 1953:178).

Like the Germans, most of the Scotch-Irish settled originally in Pennsylvania. From Pennsylvania, the major direction of movement for these groups was southward along the Appalachians, with offshoots in every direction. Eventually the building methods practiced by these two groups became the dominant construction methods for all of the Eastern United States south of New England, except for the thin Tidewater strip along the outer coastal plain (Kniffen 1965:561).

As log construction became established through time, distinctively American plans with recognizable European antecedents began to be built in specific areas. The following section will describe some of these.

First, however, a few basic terms that will be used throughout this study should be defined. "Cabin" denotes a small often temporary dwelling, usually one room in size and not more than one and one-half stories in height. While usually associated with log construction, cabins of clapboard, adobe, brick, sod, and stone have been built in different parts of the United States. In the Rocky Mountain Region, the focus of this study, the vast majority of cabins were constructed of log, and when the term "cabin" appears it will refer to a log dwelling unless otherwise noted. It should also be pointed out that log construction is a building technique, not a specific architectural form. This can be seen in the way many cultures in America embraced German log technology, but still used it to build their specific architectural forms.

Now that log technology has been established in North America, the direction of this study will turn to an examination of its application by different peoples in diverse geographical areas.

Three cultural source areas have been recognized by geographers for the Eastern United States. The New England tradition saw dwellings, even from its beginning, of exclusively frame construction. A synchronic series of house types developed, but basic construction techniques remained the same. The Tidewater South as a whole also continued this English tradition of frame construction. The third and most important source area for log technology is the Mid-Atlantic Region. It included in its inventory the "I" house floor plan, which became the most common house type from the Mid-Atlantic and on into the Midwest during much of the 18th and 19th centuries.

The only important German house type, the central-chimney or continental log house, was seldom constructed outside of German settlements in Pennsylvania. The most important contributions of this region, at least for this study, were its single and double pen cabin types (Kniffen 1963:558-581).

Single pen cabins from the Mid Atlantic were the most numerous and indeed have become the typification of the "American log cabin." The two dominant forms have much in common with each other: Both have side facing gables - the door in a wall, running parallel to the ridgepole. Both usually have an external chimney in the center of one gable end, constructed of brick, stone, log, and/or clay (Glassie 1963:341-343). The oldest of these is called the rectangular or Scotch-Irish cabin (Figure 2a). The dimensions of front and rear walls exceed that of side walls by at least five feet. This cabin may consist of a single room or be unequally divided by a light partition into two rooms, the larger of which will contain the fireplace and the door. A rear door, sometimes present, will be in line with the front door. This floor plan seems to be directly related to that of stone and mud cabins commonly built around Ulster, in Northern Ireland. In the United States, the rectangular cabin was commonly found in areas where the Scotch-Irish/Pennsylvanian influence was the strongest - into the Blue Ridge of North Carolina and Tennessee, and the Upper Piedmont of North Carolina (Glassie 1968:353-355; Jordan 1978:108).

The second form is the square or English cabin (Figure 2b). Roughly 16-foot square, it is the traditional one-bay size of ancient English dwellings. It was introduced to America as a frame structure by English colonists. Once inland, however, most were of log construction (Glassie 1968:349-353); Jordan 1978:111).

Double pen cabins were also a part of the Mid Atlantic tradition although not as common. Usually two pen construction came about through additions to originally single pen dwellings. The three most common ways this was done was to abut a second pen against the non-chimney side of the first pen (simple two pen); to build the second pen close enough to the first that they might both share a common chimney (saddlebag); or to build the second pen far enough from the first so that a passageway was formed between them by joining both pens with a common roof (Dog-trot) (Figure 2c).

As the American frontier moved westward, cabin building continued in these already established forms until it reached the "Great American Desert" - the Great Plains that stretch 2000 miles from Texas to Alberta, and average 400 miles in width between the Mississippi Valley and the Rocky Mountains. This vast treeless land saw log construction sputter and die for lack of material (Kalman and Vissar 1976:152). But such traditions change slowly; while dwellings of sod and hay might have proved more practical, log construction continued as long as it was possible to build that way (Welsch 1980:312). It has been noted that in most cases architectural form endures longer through time than the use of specific materials, but

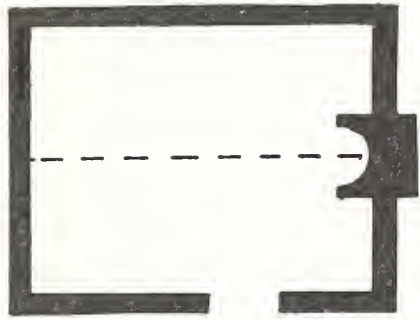

*a*

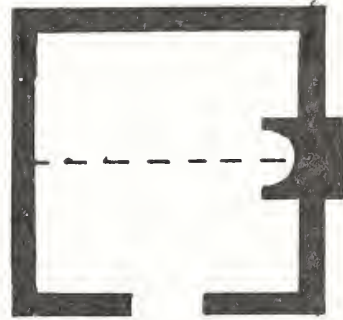

*b*

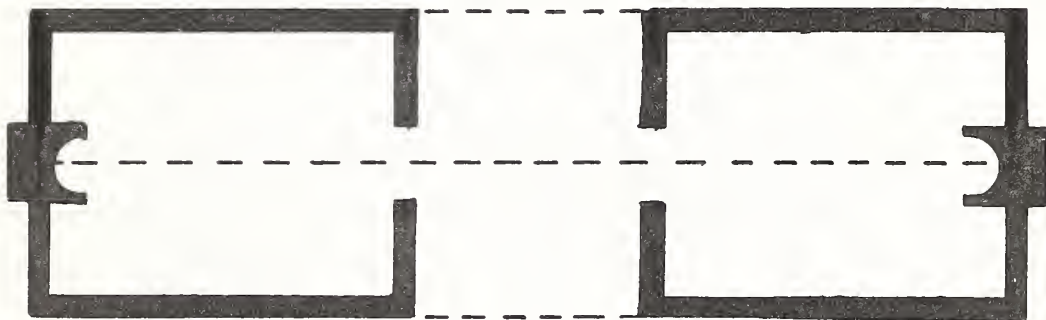

*c*

Fig. 2. Floorplans of eastern American cabin types: *a*, rectangular (Scotch) plan; *b*, square (English) plan; *c*, Dogtrot.

on the fringes of the Plains, log construction continued even when it meant altering traditional building forms. While established Eastern plans continued to be constructed from Virginia to California, a district cabin type began to make its appearance on the 19th century American Plains.

The "Anglo-western cabin," first documented by geographer Charles Gritzner (1971), has several features different from earlier American types. The most apparent change is in the placement of the doorway - moved from under an eave to a gable end, thus turning the structure so the gable faces forward. The degree of slope in the roof is diminished, dropping in most cases below 45°, and sometimes is almost flat. And, while due more to technology than typology, the iron stove almost totally replaced the fireplace as the builder's choice for heating and cooking (Figures 3 and 4).

While its definitive origin is uncertain, several logical theories about the Anglo-western cabin have been proposed. According to Roger Welsch, writing about Nebraska cabins, the movement of the door came about because "...logs were scarce on the Plains and the walls were usually low - five to seven feet high - and a door in the eave would have had to cut through the sill and plate logs, introducing structural instability. So, the main door was often centered in the gable end, thus taking advantage of a slightly higher wall." Welsch suggests that roof slope was lowered because it took fewer logs, and could better support a sod roof, common in that region (Welsch 1980:319). Another possibility outlined in a study of Texas



Fig. 3. Anglo-Western cabin along the Missouri River; photo taken in 1877 by David Carlisle (from Bealer and Ellis, 1978).



Fig. 4. Anglo-Western cabin from mining era of Dawson City, Yukon, built ca. 1900 (from Bealer and Ellis, 1978).

log building by Terry Jordan, is that the absence of wood brought about the construction of dugouts and semi-dugouts - dwellings partially excavated into a slope, with logs forming only the superstructure. A gable entrance makes the best use of space in such construction (Jordan 1978:111,113). While the origin of front-gabled log structures goes back to ancient Europe (Gimbutas 1963), prototypes can be found throughout the Eastern United States in the form of outbuildings. Specific techniques such as corner notching, appear to continue onto the Plains as westward extensions of established Eastern traditions (Welsch 1980:319).



### III. GEOGRAPHY OF THE ROCKY MOUNTAIN REGION

The Rocky Mountains make up only a short segment of the geologic backbone of the Americas that extends 10,000 miles (16,000 km) from Alaska to Patagonia. The United States part of this range constitutes a north-south barrier - the continental divide - separating the interior Plains from the Intermountain plateaus and the Pacific Mountain System. The Rocky Mountains comprise three provinces, each with distinctive land forms: the North, the Middle, and the Southern Rocky Mountains (Figure 5). These, together with the Wyoming Basin, cover about 180,000 miles (466,000 km), which is between 5-percent and 10-percent of the land area of the United States.

The region's outstanding features include:

1. High peaks, many of which rise above 14,000 feet.
2. Great relief; the summits of many or most of the ranges are 5,000 to 7,000 feet (1,500 to 2,100 m) higher than their respective bases.
3. Ruggedness, far exceeding that of the Appalachians.
4. Rocks of igneous, sedimentary, and metamorphic origins in diverse kinds of uplifts and basins.

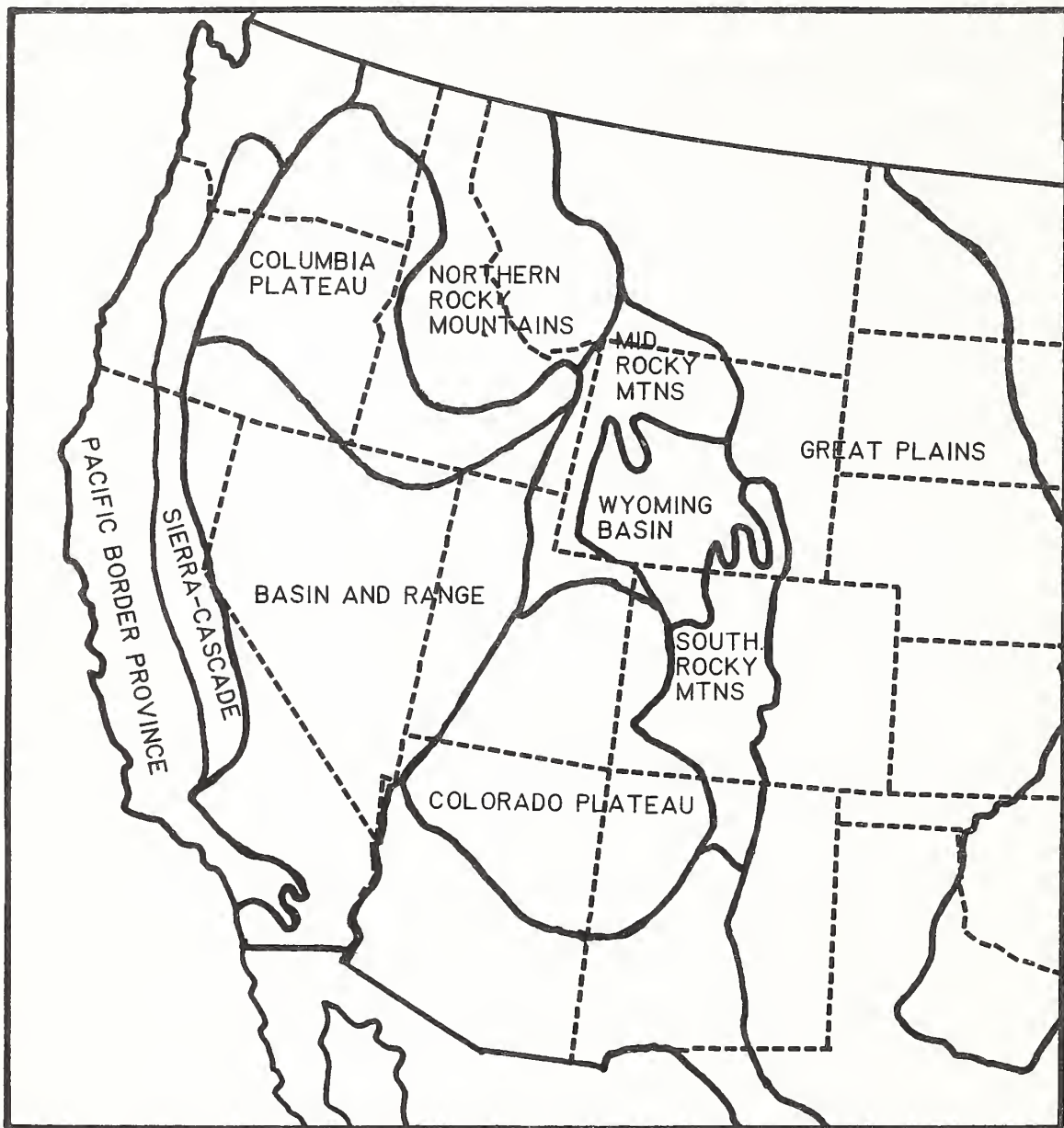

Fig. 5. Physiographic map of the western United States (after Hunt, 1967).

5. Shallow soils and extensive areas of bare rock.
6. Extensive stands of conifer forests.
7. Water supplies - it is the principal water source for a quarter of the country including the Plains to the east and deserts to the west.
8. Mineral wealth - considerable and varied.

The three principal divisions in the Rocky Mountain system each have distinctive features. The Southern Rocky Mountains form the principal barrier to travel and may be crossed only through high passes. Differences in mean annual temperatures between the mountain tops and the Great Plains average about 35° F (19° C) (the upper mountains have about the same temperature range as much of Alaska). Annual snowfall often exceeds 20 feet (6 m). The timber line reaches up to about 11,500 feet, containing altitudinally based zones of spruce, fir, and pine.

The Middle Rocky Mountains have levels of both temperature and precipitation that are slightly lower than those of the Southern Rockies. Both early transcontinental routes--the Oregon and California trails--crossed the mountains in this region. The Northern Rocky Mountain region, while not as high as either the Southern or Middle regions, is not topographically very different from them. This region supports the greatest population of the

three. Milder temperatures are found with precipitation varying with altitude, but generally drier than the lower sections. This region contains three times the wood reserves of the Southern Rockies (Hunt 1967:245-276).

Within the Rockies lie mountain parks - huge meadows, often of considerable size. As well as providing the region's agricultural base, these valleys are sources for some of the major Western rivers (Merk 1978:240-241).

#### IV. HISTORY OF THE ROCKY MOUNTAIN REGION

In order to understand the architecture of the Rocky Mountain region, a brief history of its settlement is in order. Six groups which can be viewed as playing major roles in this process will be discussed separately. First, however, a look at their antecedents.

##### A. Indians and Explorers

At the time of contact the inhabitants of the Rocky Mountains were aboriginal populations thinly scattered throughout the region. Most belonged to the Shoshone linguistic family with individual groups including the Shoshone, Bannock, Paiute, and Ute. Their occupation of individual sites was seasonal at best - spending summers in the mountains, and wintering along major water sources in the valleys and along the plateaus. While winter activities were fairly sedentary, summers were spent moving between temporary camps, taking advantage of diverse food sources (mainly hunting, fishing, and root gathering) (Sappington 1981:13-15).

Enthnographic accounts of aboriginal housing reflect the usually temporary nature of these dwellings. Winter shelter appears to have been quite variable in form, described as "a sort of tipi made of ryegrass" (Murphy and Murphy 1960:309); "shaped like haystacks and constructed of branches of willows covered with long grass, so as to be warm and comfortable" (Irving 1977:160); "made of rush mats

wrapped around cones of poles" (Farnham 1906:316). Summer housing was even less substantial: "tops of (willows) have been bent over, and tied so as to form a lodge; over these, there have probably been stretched deer skins or blankets, to exclude the rays of the sun" (Townsend 1906:247).

Given our present knowledge of these people, it does not appear they were cabin builders. Given their temporary nature, it would not have been practical to expend the amount of work necessary to build log structures. It does appear, however, that less substantial wood materials were used in house construction when available.

The first westerners to venture into the Rocky Mountains were members of the Coronado expedition, in search of the riches of the "Seven Cities of Cibola." The contingent consisted of three hundred Spaniards and perhaps a thousand Indians driving large numbers of cattle and sheep, all guided by a Franciscan Friar named Marcos. Between 1539 and 1542, their wanderings took them into what is now southeast Colorado, northern Arizona, and northern New Mexico.

The next expedition into the Rockies was headed by Lewis and Clark from 1804 to 1806. Their party, consisting of 30 westerners and 1 Indian, was the first non-aboriginal group to cross the Continental Divide, passing through what is now Montana, the Idaho Panhandle, and into Washington and Oregon. A year later (1805) Zebulon Pike led an expedition into Colorado. In the next decade, more adventurers followed those first explorers into the uncharted mountains.

Due to the mobile and very temporary nature of their time spent in the mountains, no structures of any permanence were constructed. No log structures other than crude lean-tos, have been recorded (Hawgood 1967:20-29, 67-86).

## B. The Fur Trade

The first people to build structures of any permanent nature were those who came to the Rockies for the acquisition and trade of beaver pelts. This was usually set in motion when a company opened a fort in a promising area where trappers, Indian and European, could exchange fur for trade goods.

The earliest company to establish forts in the Rockies was the English Hudson's Bay Company. Founded in 1670, Hudson's Bay Company was active in the Rocky Mountain region from the late 1700's up into the 1840's. Its primary rival, the Northwest Company, merged with Hudson's Bay in 1821, making it by far the largest fur company operating in the area (Hawgood 1967:93-94). Hudson's Bay posts included the Rocky Mountain House on the north Saskatchewan River, the Kootenai House north of Lake Windmere, the Kullyspel House on the Pend Oreille Lake, and forts Colvile and Vancouver in what is now Washington State (Johanson 1967:93-94).

American companies also attempted to establish posts in the northern Rockies. The earliest of these was Fort Astoria, opened by Ashley in 1811 but shortly captured by the British, and operated by

Hudson's Bay until returned to America to 1818. Americans continued to operate the fort until its abandonment in 1827. Other American companies set up forts in the area, but with well-established competition and the increasing settlement of the area, few were successful. In 1846 permanent treaties ceded all lands below the 49th parallel to the United States after 28 years of joint ownership, bringing to an end British control of area commerce (Clampitt 1889:656-657).

In the southern Rockies, the earliest fur trade was in progress in Colorado before 1807 by the Missouri Fur Company. The company was not on the best of terms with the Spanish, who claimed ownership to the area, and open confrontations were taking place by 1815, continuing until Mexican independence in 1821. Permanent posts included Fort Robidoux on the Gunnison River, and Fort Block (Ubhelonde and others 1972: 31-38). American trappers attempting to avoid British to the north and the Spanish to the south, began trapping the Central Rockies about 1824 (Ridge and Billington 1969:343).

Considering the cultural diversity of the groups involved, it is not surprising that the kind of dwellings constructed varied widely. The larger forts and trading houses, constructed to provide storage, shelter and protection for employees, were typically "a palisaded outpost of an empire" (Johanson 1967: 127). The earliest mention of actual construction is from 1821 - a trading post "nine logs high"



constructed by Glen-Fowler Company (Ubbelonde and others 1972:38). While descriptions are few, given the cultural background of the builders, most were probably built of log. From early drawings and archaeological investigations, Hudson's Bay dwellings shared similar construction techniques - hewed logs were joined at the corners by either being pegged or grooved into vertical logs.

The other participants in the fur trade were the actual trappers. Along with the large number of Indians involved, Americans, French Canadians, and Mexicans were also represented. Most of the non-Indian trappers stayed into the mountains year-round either as independents or "hired hands" for the fur companies. Pelts were usually brought in on an annual basis to a fort, or in parts of Colorado, a "rendezvous" was assembled for trade and entertainment (Ridge and Billington 1969:393). Even less is known about dwellings of the early trappers than those of the traders. Considering their year-round occupation, the easy access to wood, and later examples which still survive, it is probable most of these dwellings were built of log.

Because of the huge profits to be made, overtrapping began to take its toll by 1840, pushing the beaver to the edge of extinction. About the same time, European fashions began to change, with silk hats replacing beaver in popularity. While some trapping continued on a small scale and still continues today, the combination of these two factors brought an end to large-scale fur-trading in the Rockies in the early 1840's (Ridge and Billington 1969:396).

### C. Mining

Probably the most important force in the settlement of the Rockies - and the kind of dwellings constructed there - was the quest for gold and silver. The West's first gold boom came in California in the late 1840's. Next came discoveries in the Washoe area of Nevada in 1858. The first strike within the Rocky Mountain region came near Denver that same year (Hawgood 1967:200-215). In 1859, 100,000 would-be miners from the East, the Midwest, and the Mississippi Valley began a migration to the Colorado gold fields although only about half of them actually made it. Two other major strikes followed within a 4-year period. In 1862, a gold strike was made in the Boise Basin, beginning a decade of booming mining activity in southern Idaho. The next year discoveries were made in western Montana, bringing in miners from both Colorado and Idaho (Hawgood 1967: 221-223).

These gold fields seemed to be playing out in the late 1860's, but the 1870's brought new mineral booms to the mountain states. Leadville and Cripple Creek in Colorado, and the Coeur d'Alene region of Idaho became centers of activity, this time in pursuit of silver ore. Montana was also beginning the large-scale mining of copper. In 1880, a new gold field opened up in the mountains of Arizona (Ubbelonde and others 1972:112-200). The final Rocky Mountain gold rush came in the Yukon region of Alaska and Canada in the 1890's.

While existing at different times and places, life in and around the boom towns seems to have had many similarities. Populations were very heterogenous - consisting of adventurers from the East, Civil War draft-dodgers and later veterans from the South, and aliens from all over the world. "The population was like a swarm of grasshoppers...gathering quickly in the area of a strike...and disappearing with as much speed when the gold was exhausted" (Merk 1978:417).

Construction also followed similar patterns of growth. The first buildings constructed on a new field were usually canvas tents (Clampitt 1889:595). Log cabins soon followed, providing fairly permanent structures that could be used for year-round habitation. In the actual cities, frame structures would begin to replace those of log as soon as a sawmill was opened. If a town lasted several years, brick began to be used, especially for public and commercial buildings. This was particularly true in areas where fires had been a major problem. The final "step" in this process was the construction of stone and masonry buildings (Ubbelonde and others 1972: 78-79).

Outside of the population centers, few 19th century buildings were constructed of anything other than log except in places like Nevada where wood was scarce and sawmills arrived very early (Browne 1861:155). From most accounts, these non-urban dwellings continued to be single pen structures. Some cabins saw only seasonal occupation, with miners working their claims in the mountains during the

summer, and wintering in the valleys; for others, occupation of Rocky Mountain cabins was year round. Most dwellings were occupied for more than one mining season, but few miners intended these structures to be for long-term occupation. A claim would be worked while it was producing gold, but when "color" began to play out, the miner would move on to build again elsewhere. Some early cabins saw several successive occupations as the value of gold fluctuated, experiencing a cycle of refurbishing, occupation, and abandonment.

By the 1890's boom towns had either found other sources of livelihood, or died out (Ubbelonde and others 1972:161). Mining that continued consisted of professional operations with specialized equipment and the capital to sink deep shafts, or small independent operations, usually in isolated areas (Johansen 1967:322).

#### D. Farming and Ranching

One effect of the influx of miners into the Rockies was the initiation of agriculture in the mountain parks and valleys (Merk 1978:418). Most early agricultural enterprises were begun through the Homestead Act of 1862. Under this legislation, any American (citizen or alien filing for citizenship) over 21 and the head of a household could claim 160 acres of surveyed but unappropriated public lands. The original cost was \$10; after 5 years, full title would be granted for a small fee. This granting of title could be accelerated--gained in only 6 months--by paying \$1.25 per acre. Unfortunately, the act had several faults: Land speculators found

several loopholes through which they could acquire vast tracts of land. Some families would go through seven or eight farms, holding one long enough to acquire title then selling the property and moving on. The major problem was that 160 acres proved to be too small a tract to be economically viable for agriculture. Acts to provide supplemental tracts for established homesteads were passed in 1873 and 1878 (Hawgood 1967:353-355).

The homestead, unlike the mining claim, was intended for fairly permanent occupation, so the original cabin was temporary until a larger house could be built. Often these farms would be worked only until the soil was depleted, then the family would move on (this usually took several years). Many families did not get a choice about moving or staying--due to their lack of original capital and inexperience with farming practices necessary in the area. About two-thirds of the homesteads failed before title could be awarded. Another force which helped to undermine the success of small farming operations was the timber industry. At times early timber companies would "hire" troublemakers to scare off homesteaders and jump their claims (Hult 1952: 113). More often, timber companies would help a foundering farmer pay off his claim so it could be legally purchased by the company.

Ranching also grew along with the populations of early mining towns, reaching its height in Colorado about 1880. But over-grazing, profit-taking, and finally severe weather saw a collapse of the cow bonanza in the late 1880s. Large operations like those in Colorado

were not duplicated in the northern Rockies. Like cattle, sheep were also a great demand; flocks were well-established in the southern Rockies by the 1870s, a little later in the north (Ubbelonde and others 1972:167-169).

Due to the limited space and climatic extremes, inhabitants would often combine livelihoods--raising crops on a few acres and herding small numbers of cattle or sheep. For this reason, farmers and ranchers in the Rocky Mountain region will be considered as a single group.

The cabins constructed by farmers and ranchers differ little in appearance from those of miners of the same area and time period. Instead of a single or several males, the usual owners of mining cabins, homestead cabins were designed to be family dwellings and were usually larger than other cabins. The loft would often be floored to provide a sleeping area for the children. Outbuildings would also be different, reflecting specific subsistence patterns. Otherwise, few differences seem to exist in surviving archeological examples. With the exception of Forest Service cabins, early farm structures are the most likely to survive over time, for after the family has moved into more permanent quarters, the original cabin usually remains for storage or for animal use.

#### E. Transportation

While never comprising a large percentage of the population, those responsible for bringing rail service to the Rockies can be said to

have made sizable contributions to its settlement. After a major gold strike had been made, it was sometimes many years before a railroad would reach the area, leaving wagon roads or often pack trails to provide the only available transportation (Ubbelonde and others 1972:120). If accessible to larger bodies of water, steamboats were used to transport people and supplies, especially along the lakes and rivers of northern Idaho (Hult 1952:82-83). This lack of fast or economical transportation can be seen in some early construction--the use of local materials like wooden pegs instead of iron nails, leather instead of metal door hinges, and an absence of window glass. A metal drum or even rolled sheets of metal propped upon bricks, a "Queen Anne stove," was used as a substitute for a manufactured iron stove in some areas.

The need for a transcontinental railroad had been recognized ever since the discovery of gold in California. Surveys began in 1853, congressional approval followed in 1862. Large land grants for three separate routes were set aside, but the diversion of capital and the political instability brought on by the Civil War caused continued delays. Subsidies were finally granted two corporations, the Union Pacific and the Central Pacific, in 1863, with completion of this first transcontinental line coming in 1869 (Clampitt 1889: 91-96). By 1890, four railroads had been built over the mountains, providing rail transportation to Colorado, Wyoming, Arizona, and the western Montana-northern Idaho area (Hawgood 1967:260).

Railroads not only provided transportation, they often induced settlement. During the 1870's and 1880's, large propoganda campaigns were launched. Railroads wanted to sell large tracts of land they had been granted along right-of-ways, and even when not their own land, new settlers meant more business. Promotional staffs were maintained in Europe and major Eastern cities (Ridge and Billington 1969:623). Extravagant pamphlets put out in the 1880's about mining opportunities brought people from all over the country into the northern Rockies (Hult 1952:26). While most of these settlers were no doubt unprepared for actual conditions, many stayed as settlement of the Rockies accelerated.

f. Logging

While major mining towns were not without at least one sawmill, full scale logging operations in the Rockies did not get under way before 1890 (Johansen 1967:403). The "second migration of the timber industry" took place about 1900, when timber barons who had previously concentrated operations in Michigan, Wisconsin, and Minnesota moved westward, bringing new life to declining mining towns like Coeur d'Alene (Hult 1952:79-80). Small operators would cut freely on the public domain, while larger companies would either buy their land or take advantage of generous government land grants. A peak in timber production was reached about 1913, after which stricter government policies, the depletion of easily accessible timber, and some disastrous fires combined to restrict production.



Loggers were usually transient. Because of small size and the inaccessibility of their holdings, independent operators usually contracted for larger companies or mill operators, moving camp continuously to new areas for easy cutting and hauling. Many loggers were "stump rangers" - homesteaders and miners wishing to supplement their incomes. In some areas farmers made up 75 percent of timber crews (Johansen 1967:400-405). Due to their impermanence, loggers have left little in the way of structural dwellings. Those which remain are similar to the ones built by miners and homesteaders in the same area, although usually a little smaller in size. The loggers' biggest contribution to log technology can be found in the structures built for the transportation of logs, systems that deserve study in their own right.

#### G. The Forest Service

The most recent major influence on Rocky Mountain settlement has been the Federal Government, the Forest Service in particular. Proposed in 1907, it was to remove millions of acres of land from the public domain, and institute restrictions that would hopefully lead to conservation, and disease and fire control. While bitterly opposed by many Western representatives, the proposals became law virtually intact. Grazing fees were imposed, cutting limits were set - all in an attempt to make these forests a permanent American resource (Ubbelonde and others 1972:276-278; Johansen 1967:543-545).

While the Forest Service "depopulated" many areas by repossessing nonproducing mineral claims and buying up homesteads, it also brought at least seasonal occupation to some of the Rockies' most remote locations.

Fire towers and guard stations from the first quarter of the twentieth century still stand throughout most Forests; the great majority of these structures are constructed of log. Log construction of these government dwellings continued into the mid-twentieth century. While official building manuals were in existence from at least the mid-1930's, builders in many areas would apply these plans to existing local vernacular traditions. New Deal legislation, specifically the CCC (Civilian Conservation Corps), also contributed to Forest Service construction. Their credits include roads, bridges, fire lanes, and parks, as well as dwellings (Ubbelonde and others 1972:301).

## V. ARCHITECTURE

The first section of this report explored the origins of log technology and its diffusion in North America as far as the Great Plains. The second section was concerned with the groups responsible for bringing log technology to the Rocky Mountain region. This part will look at how a specific cabin type resulted from the combination of these factors. The typology of log structures in the Rocky Mountain region, particularly in the early stages of settlement, appears in many ways a continuation of styles common to the Plains and eastern United States. Extant archeological examples, however, attest to the evolution of a different, uniquely western cabin type in the latter stages of the nineteenth century. Due to the fact that the vast majority of surviving examples lie within this geographic region, I will refer to this type as the Rocky Mountain Cabin (RMC).

First, identifying attributes of this cabin type will be cataloged. Its close ties to the Anglo-Western Cabin cannot be denied: both typically have a front-facing gable, with a single door off-centered in the gable end; both have roof slopes usually under 45°; and both show the builder's preference of iron stoves over fireplaces. The probable reasons for these attributes being present in cabins from the Great Plains have already been discussed. Why they continued to be popular in areas where wood was again plentiful indicates that there continued to be advantages in using those techniques.

The front-facing gable was useful on the Plains because it allowed the construction of lower buildings, thereby using fewer logs. Its primary advantage in the mountains was that it allowed easier access to the cabin door during periods of heavy snowfall - a door under an eave could prove difficult when snow began drifting or sliding off the roof. A lowered roof angle meant not only easier construction, but allowed snow to remain on the roof, providing added insulation. Like Eastern fireplaces, stoves were traditionally placed against a gable wall. Ideally, the stove would be placed next to the door, as close as possible to an exterior woodpile for easy access to fuel. Because of the small size of most of these cabins, the placement of both the door and stove against the front wall meant the door could no longer be centered. Usually it was off-centered in symmetry with the stove. Examples of these cabins also continued to be built in the semi-dugout variation, due more to its insulative properties and the lack of level ground, than to a shortage of logs. These attributes help to explain why the Anglo-Western Cabin saw popularity in the Rocky Mountains, but the Rocky Mountain Cabin has an additional feature: the gable end of the roof extends to an average of 50 percent beyond the front of the cabin. The extension usually was so long that added support was necessary at its termination, this taking the form of vertical posts.

Front-gabled structures with roof extensions are not unique to the Rocky Mountain area. Neolithic examples of vertical post structures with probable roof extensions have been archeologically located in Northeastern Europe (Figure 6) (Gimbutas 1956:122,145). Historical

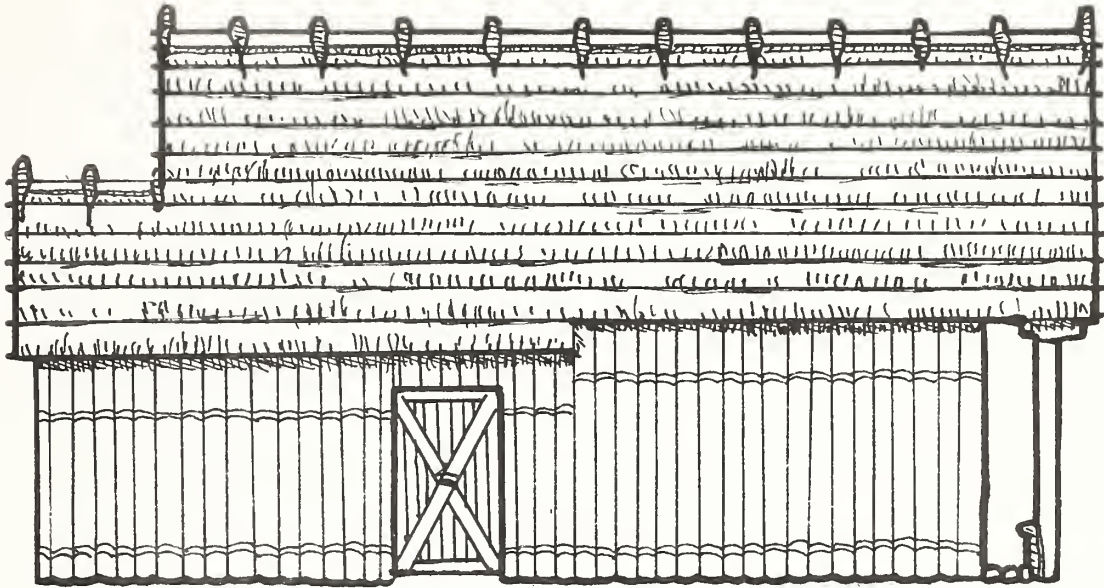

Fig. 6. Reconstruction of a house from the village of Succase near Elblag (after Gimbutas 1956).



Fig. 7. Rocky Mountain Cabin with a gable extension nearing 100% the length of the actual cabin; a Forest Service structure from ca. 1930 (from Carrey and Conley 1977).

examples of such construction are present in Germany, Sweden, and Finland (Richards 1978:109). The Megarons of Classical Greece also made use of such construction (Moholy-Nagy 1957:84). In the United States, structures with a gabled roof projected above the door were common throughout the eastern United States in the form of smoke-houses, stables, tool sheds, kitchens, corncribs, bake ovens, chicken coops, coal houses, spring houses, and washhouses (Figure 26) (Glassie 1968a:8,9). The use of this structure in the eastern United States as an actual dwelling is not documented.<sup>1</sup>

The RMC's extension is distinctive from these in several respects. The most obvious of these being its extreme length, sometimes 100 percent beyond the actual length of the cabin (Figure 7). The second, and in typological terms the most important factor, is the use of the space beneath the extension. Historical and archaeological evidence strongly suggests this area was a living space, making the Rocky Mountain cabin in many ways, a two-room cabin. This conclusion is based on photos of abandoned cabins and historical photos of inhabited structures. It can best be observed through seasonal variations in the living patterns of the cabin residents. A "typical" winter floorplan is shown in Figure 8.

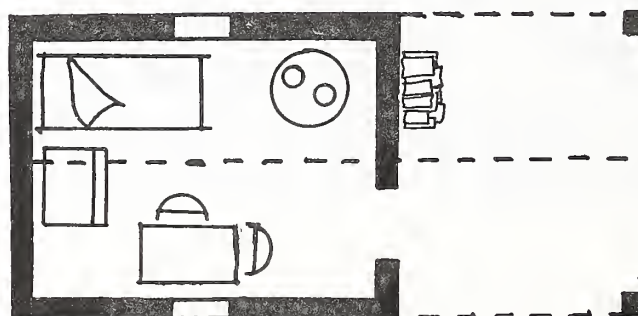

Fig. 8. Rocky Mountain Cabin, Winter Floorplan

In summer, however, as temperatures moderate and activity became more outdoor oriented, the living areas would change significantly (figure 9).

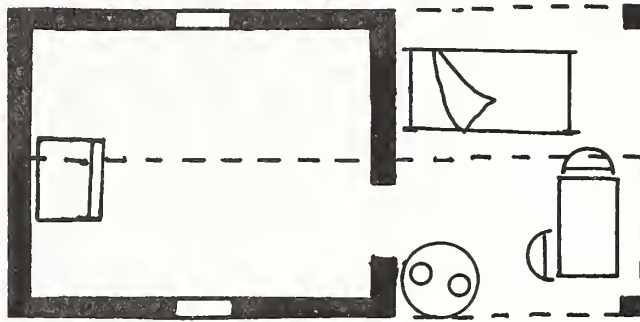

Fig. 9. Rocky Mountain Cabin, Summer Floorplan.

During the warmer months, activities were moved from the cabin's "inner" to its "outer" room. Mobile furnishings--usually storage shelves and beds--were moved to the outer room. The stove was usually moved, but if this proved too difficult, a separate outdoor stove was "manufactured" from a metal drum, rocks, bricks, or whatever materials were available. Nonmobile interior furniture was also replaced by outdoor counterparts--especially tables, made large enough to provide a satisfactory work surface and often made too large to fit through the cabin door (Figures 10 to 12). This exterior room was in most cases fully floored and on the same level as the inner room (there are examples where both had dirt floors). Additional space for the outer room could be made by adding onto it a tent extension. The space inside the gable extension saw different uses. In some cases this area was left open at the front and used for exterior storage. If a large family occupied the dwelling, the



Fig. 10. Simond's cabin, Payette National Forest, Idaho. Note bed on porch and gable extension opening to the outside; typical of miner's cabin during summer occupation (from Hartung, 1978).

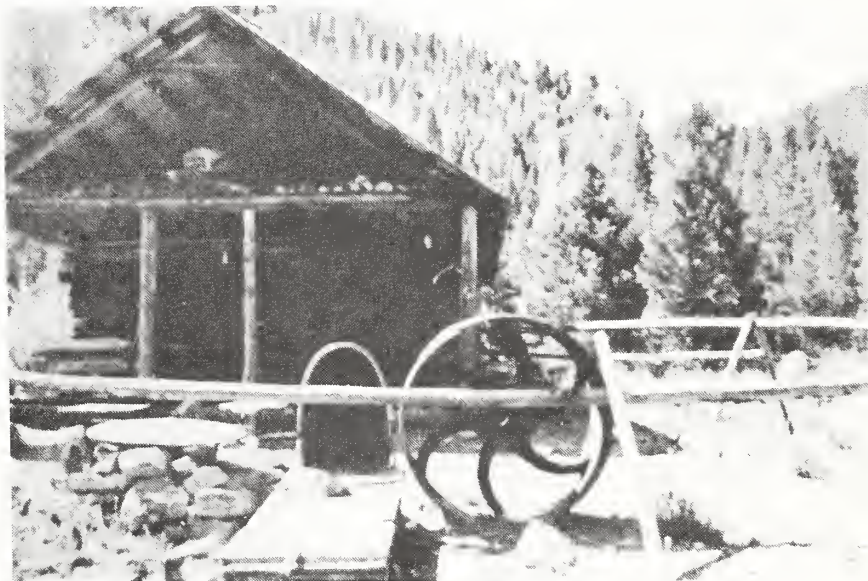

Fig. 11. Simond's cabin, Payette National Forest, Idaho. Note outdoor stove in foreground (from John Hartung).





Fig. 12. 1880s miner's cabin, Boise National Forest, Idaho. Note accessibility provided by gable extension during heavy snowfall (from Jerry Wylie).



Fig. 13. 1925 photo of winter campsite of A. B. Curtis; cabin entirely buried by snow (from University of Idaho Historical Collection).

extension would often open from the interior direction, offering storage for interior belongings and sleeping space for children (Figure 14).

This cabin type also proved practical for seasonal occupation. The outer room continued to be the living area during the summer, with the inner room providing storage space for tools and equipment during the winter.

Much variation exists within the type itself (Figure 13). While the majority are made of log, frame structures also exist (Figure 15). Within log construction, the majority so far analyzed make use of square notching, a type present, but not common east of the Rockies.

Examples can be found of Rocky Mountain Cabins made with saddle, half dovetail, full dovetail, "V" notch, and box corner construction techniques (Table 1).

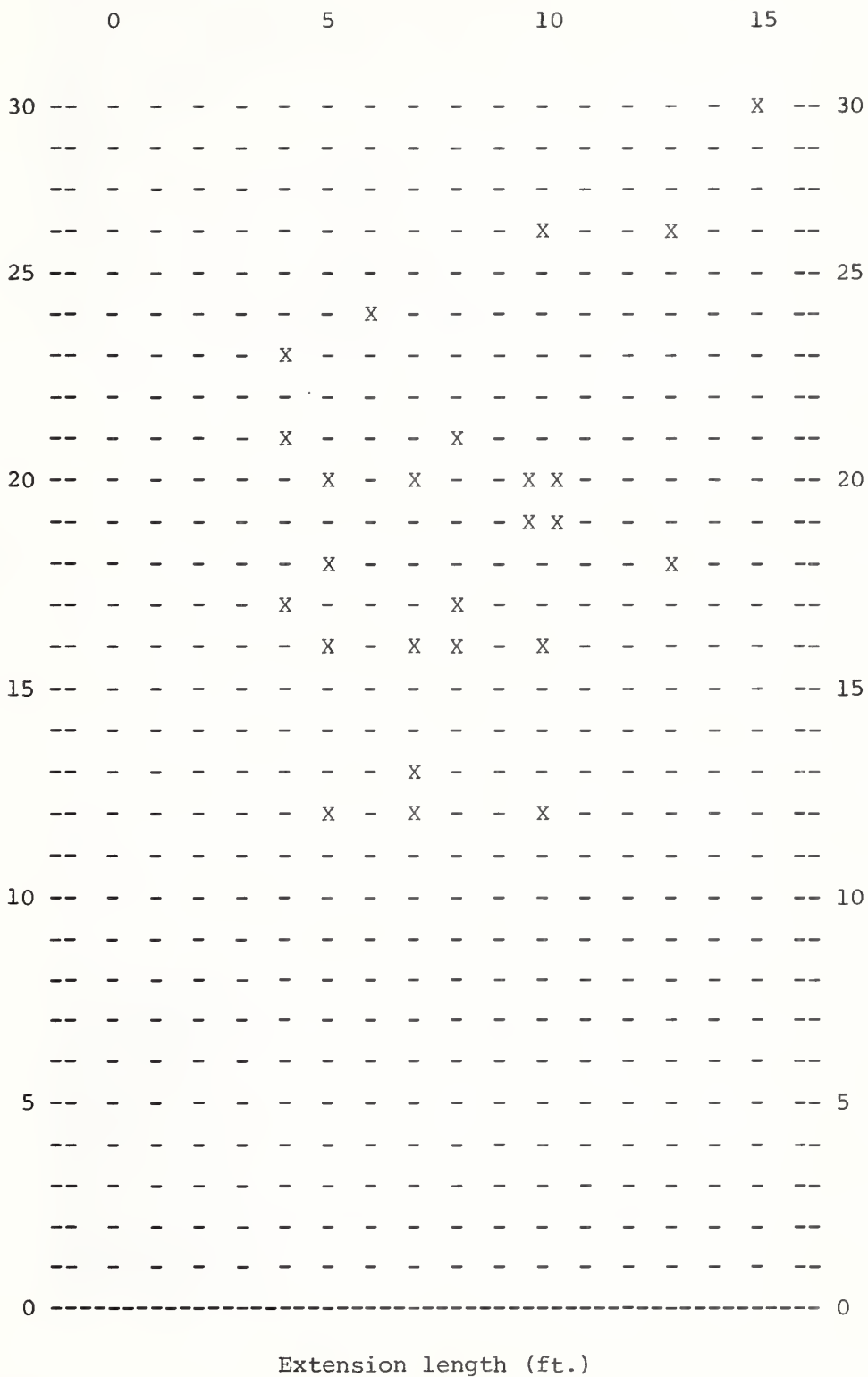

Fig. 14. Scattergram of the cabin lengths and gable extension lengths in northern Rocky Mountain cabins.



Fig. 15. Wyle's ranch, Payette National Forest, Idaho. Note  $1\frac{1}{2}$  story height of cabin and stove under extension (from John Hartung).



Fig. 16. Twentieth century frame homestead from Oregon (Hatton, 1977).

TABLE 1

Notching Types Present in Rocky Mountain Cabins

---

---

Type	No.	Percent
Square	29	48.3%
Saddle	14	23.9%
Dovetail	7	11.6%
"γ"	5	8.3%
Box Corner	4	6.6%
Other	1	1.3%
TOTAL	60	100.0%

---

Variations in roof styles include simple gable, gambrel (Figure 16), shed (Figure 17), and hip. The length of the gable extension is quite variable, but appears to average 50 percent the length of the cabin. The most unusual variation involves cabins with gable extensions on both ends of the cabin - at least two examples of this exist in different parts of Idaho (Figures 18 and 19).

One area still not discussed about the RMC is defining its difference from the Anglo-Western cabin; how long must the gable extension be

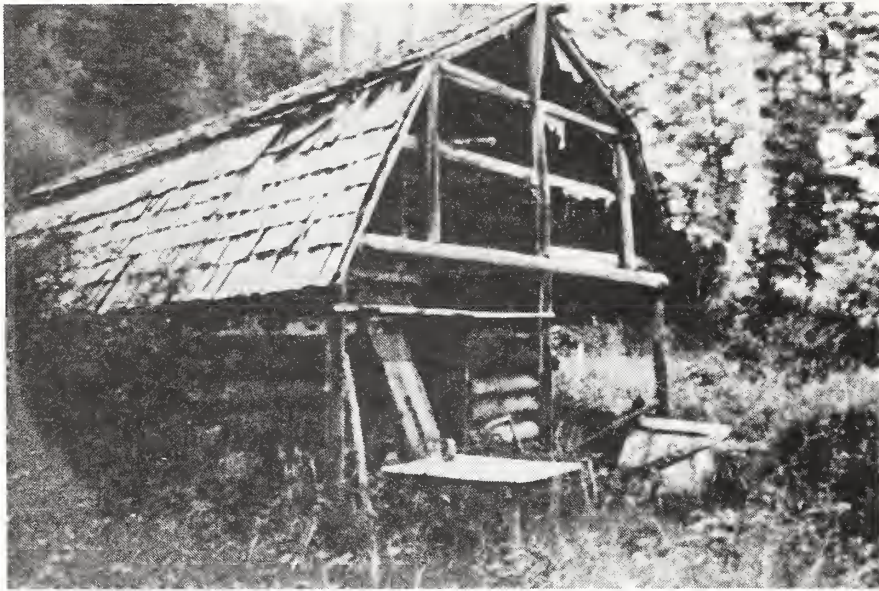

Fig. 17. Twentieth century miner's cabin, Payette National Forest, Idaho. Note gambrel roof, exterior table, and dog sled leaning against front wall of cabin (from Hartung, 1978).



Fig. 18. Miner's cabin, Payette National Forest, Idaho. This unique cabin features a shed roof (from John Hartung).

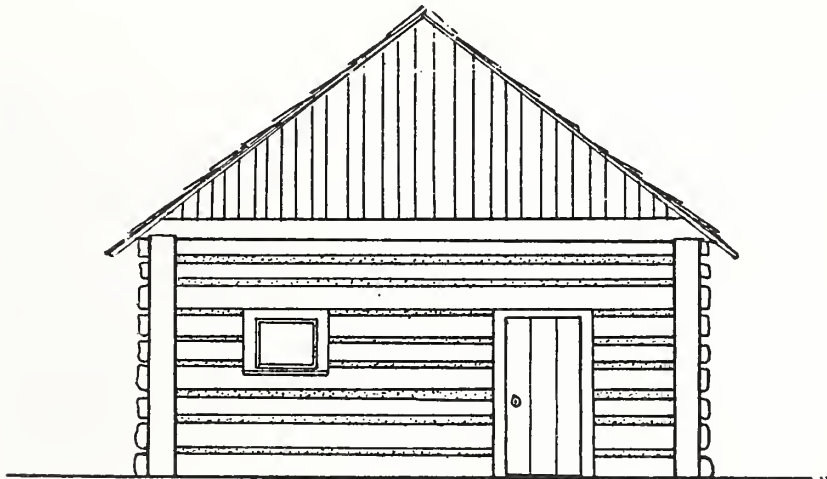
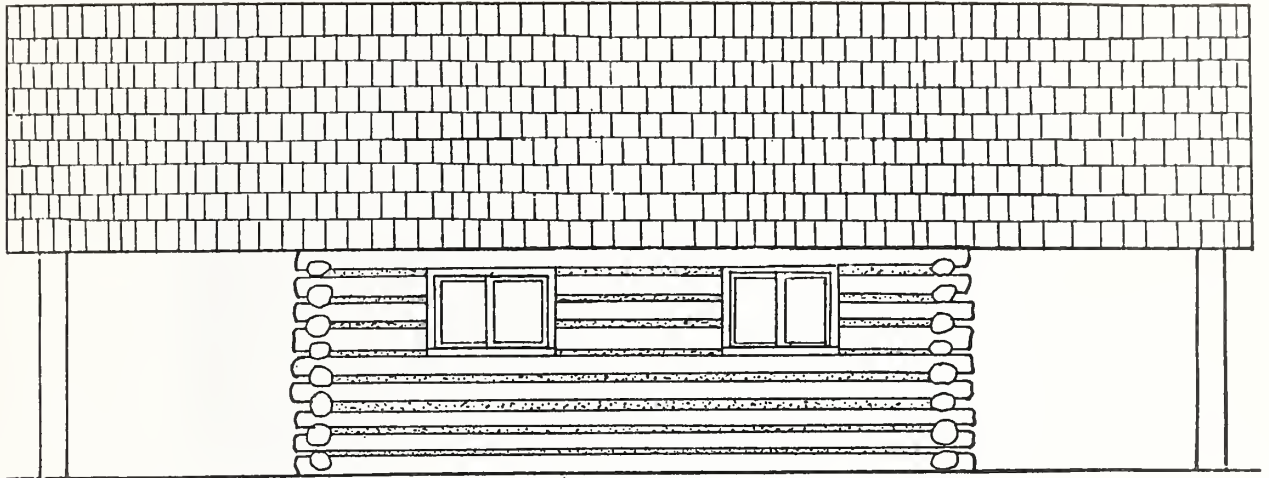

Fig. 19. South and East elevations of Norton cabin, De Smet, Idaho.  
Scale: one-eighth in. equals one ft.

for a cabin to qualify as one and not the other? While cabins with intermediate or transitional length gables occur in Idaho and elsewhere, I consider the defining attribute to be how the covered area was used - was it only a porch to cover firewood and tools, or was the area used by people as a living and working space? This is best determined when dealing with period photos, where the kinds of material goods appearing under the gable made this determination possible (Figures 20 and 21). When one has no examples other than abandoned and often deteriorating structures which offer no material clues, archeological excavation is probably the only method of determination.





Fig. 20. Nineteenth century homestead, location unknown (from the Washington State University Photo Collection).



Fig. 21. Homestead along the Middle Fork of the Salmon River, Idaho. Photo from ca. 1902 (from Carrey and Conley, 1977).

## VI. PAST DOCUMENTATION

References to Western cabin types are few; providing a date for the inception of this cabin type through historical sources has proved difficult. D. C. Beard, in his 1914 book Shelters, Shacks, and Shanties shows plans for the construction of a "Wyoming Olebo", described as having "a roofed-over open-air room, or, if you choose to call it, a front porch, veranda, stoop, piazza, or galley, according to the section of the country in which you live..." (Beard 1914:171) (Figure 22a). Beard's example shows the gable extending 56 percent beyond the cabin. Another variation is presented by Beard, called the "Hoko River Olebo." This cabin, designed for less severe climatic areas, has a smaller extension with roof supports that could be removed during nonsnow months (Beard 1914:173-173) (Figure 22b). A Forest Service Handbook from 1935 written by C. P. Fikes includes a similar floor plan and construction information, also a 56 percent gable extension (Fikes 1935: Plan C-17). A more elaborate book on log building from 1945 and co-authored by Fikes, has several examples of and variations on this plan in western Forest Service construction (Fikes and Groben 1945:21, 32, 38).

Another historical source is early photography. Nineteenth century photos exist in which RMCs make the background for portraits of early frontier families. From the early twentieth century (1909), the Forest Service has been building cabins in the region, and numerous photos of these early sites survive. The primary sources

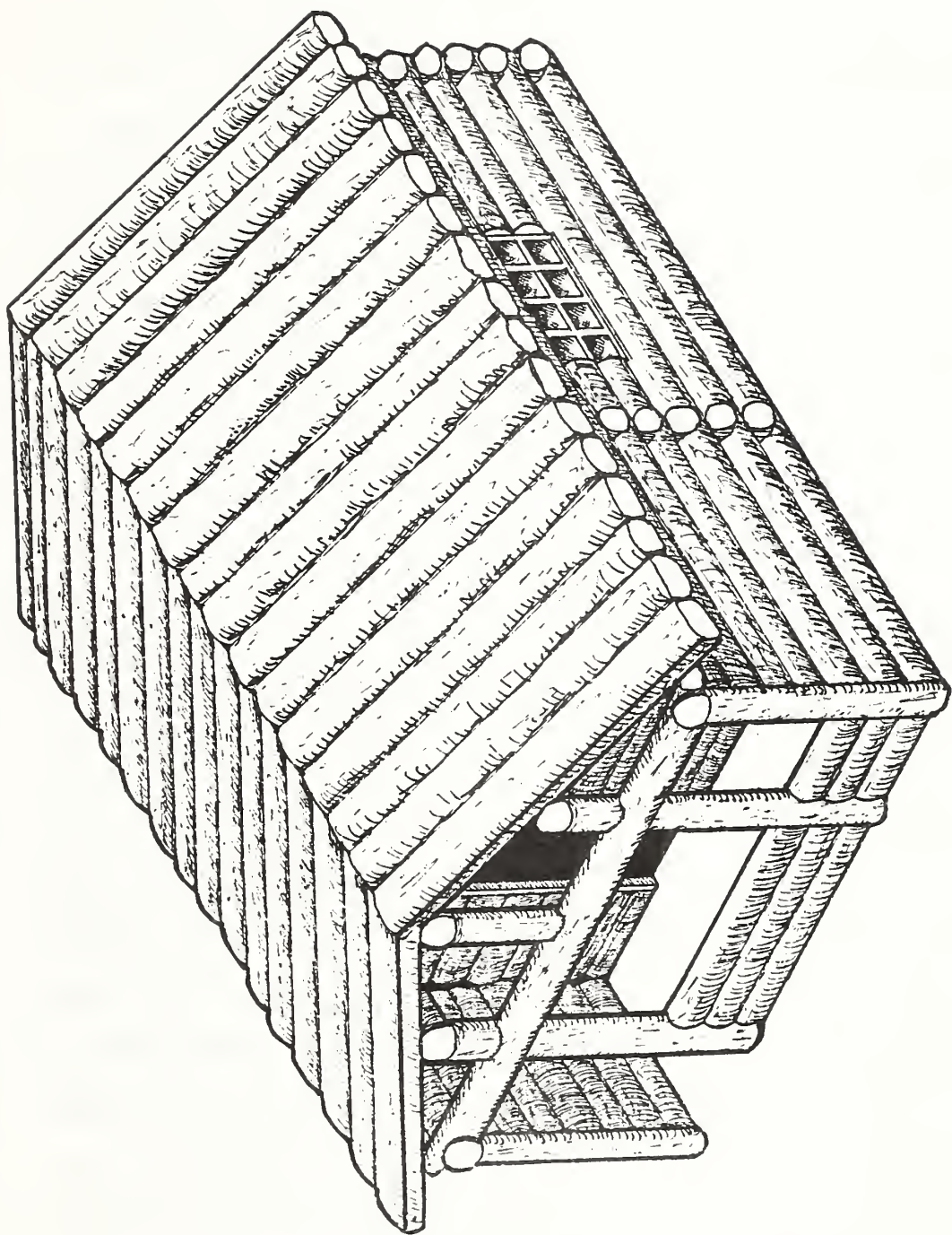

Fig. 22. A Wyoming Olebo cabin (after Beard, 1914).

of data for this report, however, are studies of physical remains. The dating of extant structures without an oral informant or datable photo is difficult. Many sites have been claimed and reclaimed several times between 1860 and 1980, with structures being built, altered, and destroyed, leaving one unable to use claim records as reliable dating mechanisms. Cabins have been known to appear in areas where official claims were never filed. The use of dendrochronology (tree-ring dating) to provide construction dates for log cabins has seen little application, but in appropriate areas may prove to be the most accurate dating method. Until a better system is developed, one cannot reliably locate a "source area" for the RMC. Even now as structures continue to disappear unrecorded, it may be too late to find such a location.

No correlation appears to exist between a specific subsistence method and this cabin type. Surviving examples were constructed by miners, homesteaders, ranchers, and loggers, as well as by the Forest Service. While it cannot be considered a determining factor by itself, differences in average cabin sizes appear when the structures are grouped according to their use (table 2). The following data, part of a study of historic structures in the Big Creek drainage of central Idaho, show a comparison of structures based on their architectural type and probable use. This study, done by John Hartung in 1978, represents one of the very few extant reports that provides a detailed cataloging of structures anywhere in the western United States (Tables 3 and 4).

TABLE 2

Average Cabin Sizes by Usage, North Idaho Rocky Mountain Cabins.

---

---

Use	Width	Length	Percent Extension of Length
Homesteads	15.6	19.6	50%
Mining	14.25	19.1	43%
Logging	14.5	17.9	32%
Forest Service	12.7	14	54%

---

TABLE 3

Cabin Usage Within the Big Creek Drainage, Idaho

---

---

Use	Number	Percent
Mining	8	32%
Homesteads	9	36%
Forest Service	6	24%
Logging	2	8%
TOTAL	25	100%

---

TABLE 4

Cabin Types Present, Big Creek Drainage, Idaho

---



---

Cabin Type	Mines		Homesteads		Overall	
	No.	Percent	No.	Percent	No.	Percent
Rocky Mountain	9	38%	9	41%	18	38%
Anglo-Western	8	33%	7	32%	15	32%
Eastern	<u>7</u>	<u>29%</u>	<u>6</u>	<u>27%</u>	<u>13</u>	<u>30%</u>
TOTALS	24	100%	22	100%	46	100%

---

Based on present information, the RMC seems to have first appeared in the Rocky Mountain Region at least 20 years after actual settlement had begun. The earliest datable cabin is from the 1880's. The dominant construction period for RMCs came between 1900 and 1930, with cabins still being constructed this way into the 1950s (Figure 23).

The majority of cabins illustrated in this report are located in Idaho. While this is primarily due to my proximity to the area and its data, Idaho appears to have the highest percentage of RMC's from any area within the Rocky Mountain Region. A preliminary survey of RMC locations has been made: data compiled from 27 National Forests in 7 western states. Among these Forests, 26 report the RMC extant.

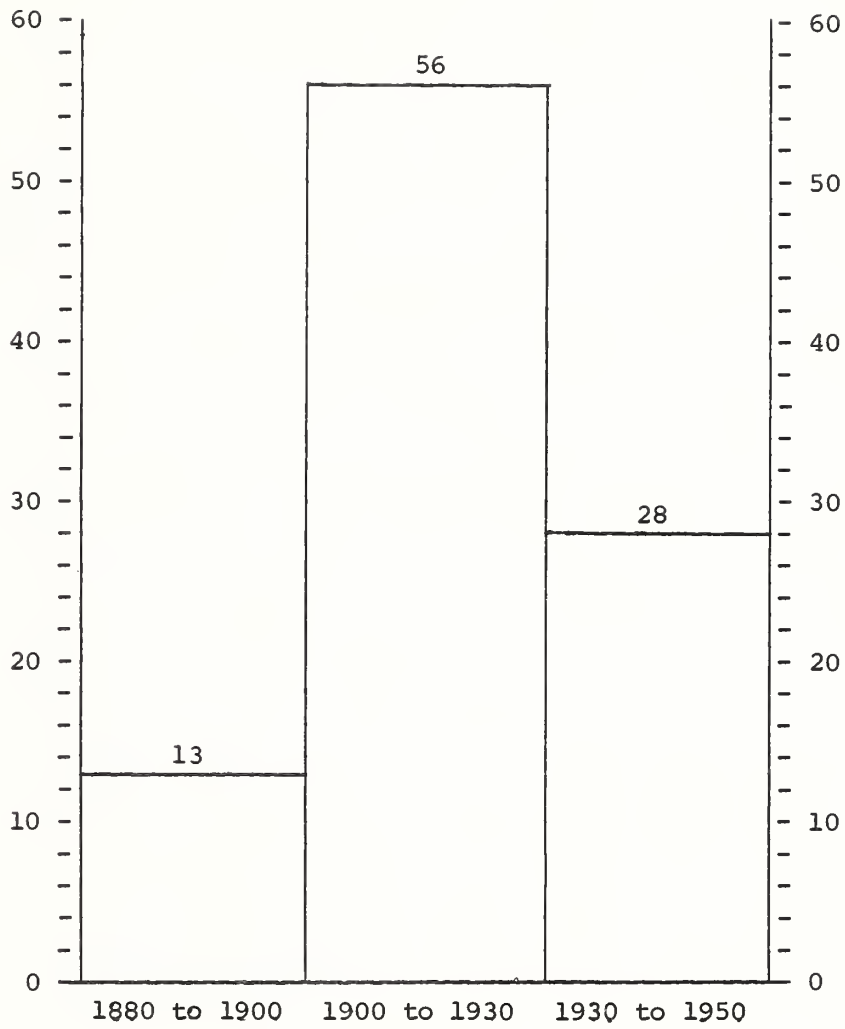
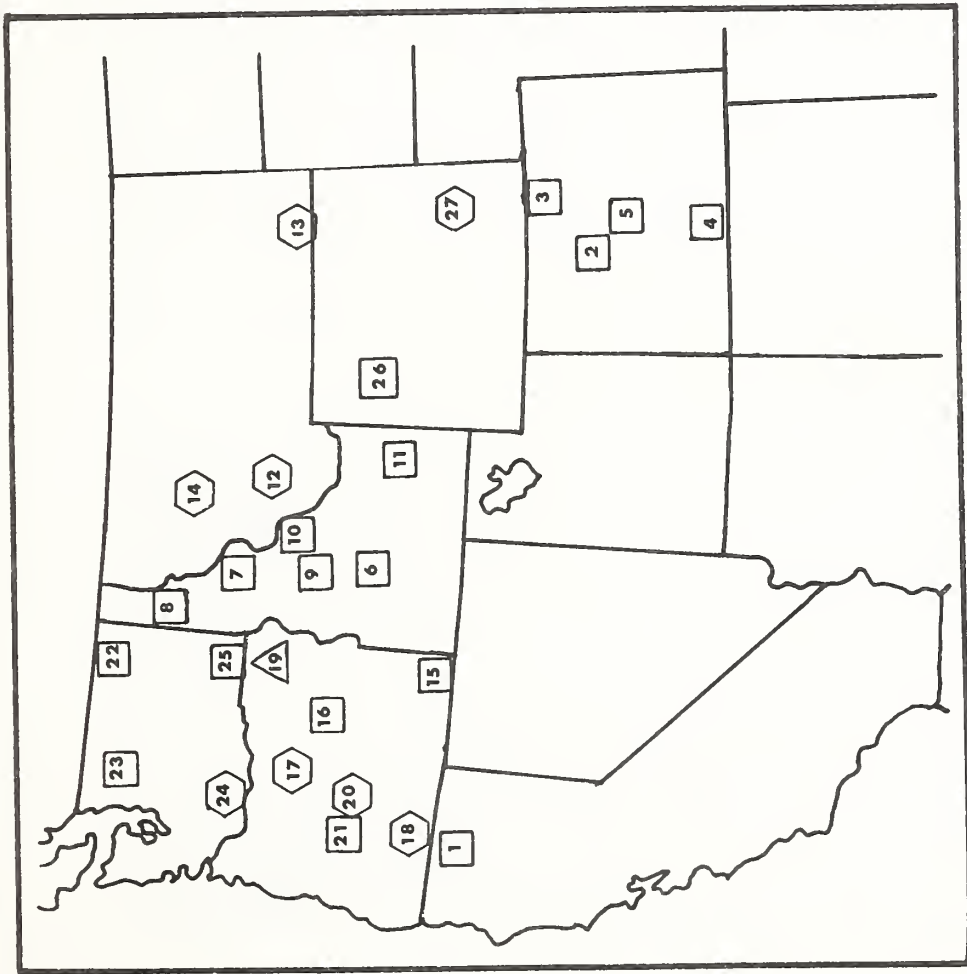

Fig. 23. Temporal distribution of a sample of datable Rocky Mountain cabins.

A distinction is made in this figure between Forests reporting the RMC present as Forest Service structures only, and those possessing RMCs constructed for nongovernment purposes (Figure 24).





No.	State	Forest
1	California	Klamath
2	Colorado	Gunnison
3		Rio Grande
4		Routt
5		White River
6	Idaho	Boise
7		Clearwater
8		Panhandle
9		Payette
10		Salmon
11		Targhee
12	Montana	Beaverhead
13		Custer
14		Lewis and Clark
15	Oregon	Fremont
16		Malheur
17		Ochoco
18		Rogue River
19		Umatilla
20		Umqua
21		Winema
22	Washington	Colville
23		Mt. Baker
24		Mt. Hood
25		Wallowa-Whitman
26	Wyoming	Bridger-Teton
27		Medicine Bow

0 0  
 300 mi  
 300 km

"□" indicates RMCs occurring as both Forest Service and private structures;  
 "◡" indicates RMCs occurring as Forest Structures only;  
 "△" indicates RMCs are not present in either form.

Fig. 24. Map and list of a sample of National Forests in the western United States, showing the distribution of Rocky Mountain Cabins.

## VII. VERNACULAR THEORY

Antecedents of the RMC could be "picked from pre-existing types with a little imagination. From the viewpoint of an anthropologist, however, the placement of this cabin type into theories of innovation - the understanding of the process of change - is a more useful approach.

Most cabin-building in the United States, at least until the last 20 years, falls under the rubrick of "vernacular architecture," a term which should be defined before given further use. Eric Mercer, writing about English vernacular architecture, provides three requirements: (1) houses of traditional form, built in traditional ways, built of traditional materials; (2) they are common within, and peculiar to, one or more limited parts of the country; and (3) they are small and mean in comparison to some of their neighbors (Mercer 1975:1).

Sibyl Maholy-Nagy, writing specifically about North American architecture, gives four aspects that are emphasized in vernacular building: (1) unsupplemented use of native materials and local construction materials; (2) planning and massing as the result of specific unduplicable functional requirements and site conditions, regardless of symmetry or generally accepted taste canons; (3) absence of ornamentation that is not a part of the structure; and (4) identity of enclosing or enclosed space (Maholy-Nagy 1957:72-73).

By far the most comprehensive look at vernacular or folk traditions in the United States comes from Henry Glassie. In his analysis of the East, three "cultures" are recognized - the academic (elite, progressive), the popular (mass, normative), and the vernacular. Folk material generally displays major variation over space, minor variation over time. Because of this, culture areas can be defined. Building types are traditional (defined as being old and acceptable to the individual that produced it). The most important and unchanging vernacular component is form in systems that favor replication over innovation (Glassie 1968:4-8). In a later book concerned with folk areas in middle Virginia, Glassie further crafts these architectural traditions into a set of rigid rules for the planning and massing of structures. Within any folk area, the "acceptable" types of architecture were surprisingly small - with success found in repetition, not originality (Glassie 1975:68,88,163).

#### A. APPLICATION

Based on definitions provided by Mercer and Maholy-Nagy, I have listed four elements that I believe can be used by the disciplines of both anthropology and architecture to define examples of vernacular construction:

1. Individual variation within prescribed traditions.
2. Limited geographic range.
3. Made by local builders using native materials.
4. Absence of overt ornamentation.

found in the East, but not in the 19th century Rockies. This has been noted elsewhere in the West by Charles Gritzner, writing about New Mexico architecture: "Folk housing traditions generally involve a high degree of consistency in both form and dimension...(but) log buildings represent a myriad of heterogenous forms and construction methods... The creativity of individuals is readily apparent not only from village to village but within villages and even on single farmsteads..." (Gritzner 1971:56). This "experimentation" is apparent in Rocky Mountain vernacular construction.

If both "systems" represent vernacular construction, can their diversity be explained? The group studied by Glassie can be considered as having fairly closed cultural system. The area had been settled with a stable population for 200 years, the majority of the inhabitants being of English or African ancestry. Most were involved in agriculture as multi-generational family enterprises (Glassie 1975:5-7). In this kind of environment, there was time for traditions to grow and be perpetuated.

In the Rocky Mountain region, cultural systems were far more open in nature. Settlement had been going on for about 50 years, much less time in many localities. Original settlers moved on to be replaced by new, a pattern which made continuation of traditions difficult. Cultural backgrounds represented all geographic areas of the United States, and parts of Europe, Asia, and Africa. <sup>3/</sup> The common element for these individuals was their need to survive the harsh, often unfamiliar climate. This need for survival, along with no

Rocky Mountain cabin construction meets these requirements. During this study, it was exceptional to find two cabins having exactly the same dimensions (Figure 25). Even with this diversity, the RMC's have much in common: all are square or rectangular in plan; most are built of horizontal logs held together by one of four notching types. Range appears to be limited by the Rocky Mountains to the east and south, following the mountains north into Alaska and west into California. The primary construction material is provided by forests of pine, fir, and cedar. The cabin's owner was usually the builder. Finally, the plainness of these dwellings is obvious--no extra ornamentation is evident in any examples so far--none are painted (except a few with preservative materials). The only nonfunctional item commonly found on RMCs is a set of deer or elk antlers on the gable's end.

When information on Rocky Mountain cabin construction is compared with Glassie's findings concerning vernacular culture areas, several problems become apparent. Glassie's definition of tradition does not apply because settlement of the area is not old, nor is its architecture credited to any specific group from elsewhere. While form appears to remain fairly unchanging among Eastern vernacular groups, major changes are observable in the vernacular structures of the Rockies within the 30-year period 1865-1890. The continuity of form can also be challenged in Plains construction, where the use of logs as a construction material continued even when it is necessary to change forms to do so (Welsch 1980:319). A third problem involves the favoring of replication over innovation, a characteristic

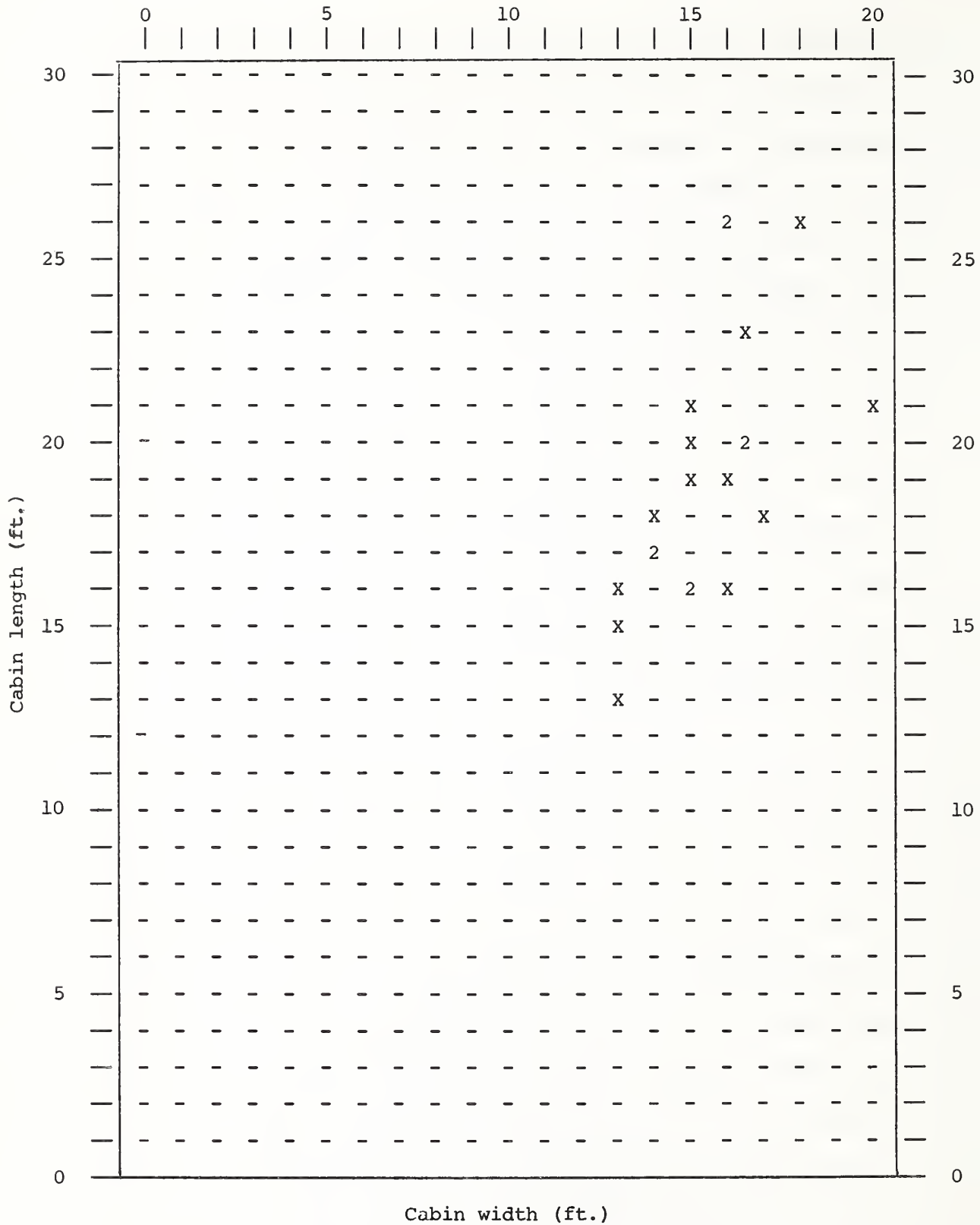

Fig. 25. Scattergram of northern Idaho Rocky Mountain cabin sizes, excluding gable extensions.

established cultural group to pressure the continuation of established forms, were two factors favoring experimentation and innovation within the vernacular architecture of the area. After several decades of experimentation, the RMC can be viewed as a step toward consistency on architectural form. To understand how this came about, it will be useful to explore the processes involved in innovation.

The best source I have found for the study of change is Homer Barnett's "Innovation" (1952), and the following comments represent a brief summary of his ideas. Two sources provide the raw materials for innovation--the physical world, and the inventor's cultural inventory. The mechanism of inventing is viewed as the alteration and recombination of "configurations," from pre-existing prototypes into new ideas that are qualitatively different from things that were previously known. The potential for the formation of new ideas is governed by two sets of factors--external conditions, and the internal wants of the individual. Once a new idea has found expression, it must be adopted by others if it is to be perpetuated. This is dependent upon the position and prestige of the original advocate, the acceptability and desirability of the idea in terms of established norms, and finally, the personality and position of potential acceptors.

Sources for the development of the RMC would be, physically, the climatic conditions--cold, snowy winters and warm, humid summers--and also a plentiful supply of wood for building purposes.

Culturally, the presence of people from diverse architectural traditions who shared a familiarity with log construction. This broad base of construction experience, along with the presence of no dominant tradition, and the need to find practical forms of shelter, qualify as external conditions favoring innovation. For the categories of individual wants and advocate qualities, not enough information is available on the RMC to make any useful comments. As for acceptability, the RMC does not violate any general features of American cabin construction, but is a recombination of them. This would allow its identification and probable acceptance by Rocky Mountain settlers.



## VIII. ORIGIN OF THE ROCKY MOUNTAIN CABIN

Without knowledge of a specific source area or datable cabins that demonstrate changes over time, determining a single prototype for the RMC is not possible, however, with the knowledge of groups settling the area and their previous building traditions, four possibilities can be suggested. Each of these represents one of Barnett's suggested changes through which new ideas are formed:

1. The elaboration of construction forms brought to the Rocky Mountains by immigrants from northwest Europe. The Rocky Mountain region saw first generation settlement from Germany, Sweden, and Finland <sup>2/</sup> --areas where front-gabled structures with modest overhangs were constructed. The ability of this cabin type to withstand the severe climatic conditions was observed by other settlers who copied its form, exaggerating the overhang for additional protection.
2. The assimilation of eastern United States outbuilding types. The majority of settlers entering the Rocky Mountain region were native-born Americans. As already mentioned, the extended front-gabled outbuilding is quite common throughout the mid-Atlantic and Southeastern United States. A settler who constructed a traditional outbuilding might have noticed advantages in its overhang and used it in the construction of his next dwelling--an idea then copied and elaborated on by others (figures 26 and 27).

3. Simplification of the Southern Dogtrot. The Dogtrot has the distinction of being the only other American cabin type that incorporates an open living space as a part of its design. The Dogtrot first made its appearance in 18th-century Virginia and Tennessee, spreading to the Central Gulf Plain where it became a common building form from Georgia into east Texas, and finding its way as far north as Indiana, Illinois, and Iowa. The earliest Dogtrots were made by the joining of two common single-pen cabins under one roof. "Second generation" Dogtrots, however, saw their doors moved to the facing gable walls, with windows moved to the front wall (Jordan 1978:119-123). This later style of Dogtrot would meet all the requirements of the RMC if only one of the pens was deleted, leaving a single pen and connected covered area.

Several Dogtrots are known to have existed in central Idaho (Figures 28 and 29). The presence of Southerners in early Rocky Mountain settlement is apparent from the names given features in the area (Atlanta, Chattanooga, Leesville). Limitations placed upon these people by geography and time, along with the need for reduced space, might have resulted in a simplification of this more complex form. Additional support for a Dogtrot origin comes from Alaska--cabins have been observed where an original RMC had been altered by the addition of a second pen, making the dwelling into a Dogtrot. From this viewpoint, cabins with small or transitional gable extensions might be viewed as further Dogtrot simplifications.



Fig. 26. Georgia corncrib, ca. 1840 (from Bealer and Ellis, 1978).



Fig. 27. Outbuilding, Hand mine complex, Payette National Forest, Idaho (from John Hartung).

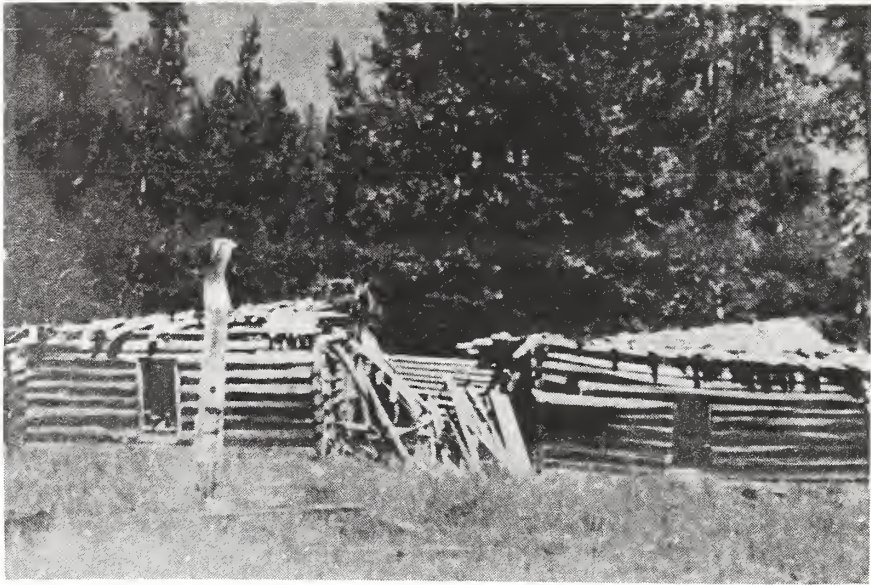

Fig. 28. Mahan mine building, Payette National Forest, Idaho; an example of a first generation type of Dogtrot (from John Hartung).

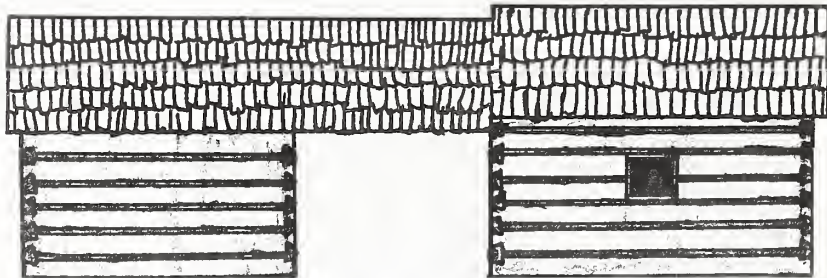

Fig. 29. Miner's cabin on the Gold Fork River, Cascade Ranger District, Boise, National Forest, an example of a second generation type of Dogtrot.

4. A purely local innovation. The Anglo-Western cabin type had been established before Rocky Mountain settlement began, and appears throughout the region, usually with minimal gable extensions in both ends. In order to store more wood and supplies outside the front of the cabin, the front gable was extended. Gradually, as longer extensions were constructed, use of the space beneath the gable increased. Numerous examples of what might be termed "transitional" extensions can be found on cabins throughout the Rocky Mountain region (Figures 30 and 31). Limits on the length of the extension would be governed by the maximum length of available logs, or possibly, by limiting the covered area to a size large enough to fulfill the needs of the builder. No standardization of extension lengths appears to have existed other than those prescribed by the Forest Service.

While it cannot really be considered as the source, the Forest Service deserves mention because of its major role as a diffuser of this cabin type. The RMC became popular as a Forest Service plan for guard stations and lookouts throughout the Western United States (Figures 32 and 33). Construction of these structures can be documented from 1910 and into the 1930's. While much work still needs to be done in the way of local studies before this relationship is fully understood, it appears to be a unique example of a vernacular building form being spread by an agent of the popular culture, yet the form remaining vernacular in nature.



Fig. 30. Cabin with minimal extension near Libby, Montana. Although only a small area is covered, note shelves built under the window to make use of this space (from Guy Marden).



Fig. 31. Hopkin's cabin, Middle Fork of the Salmon River, Idaho. Photo taken ca. 1910, note large size of logs used in cabin's construction and small stool under gable extension (from Carrey and Conley, 1977).

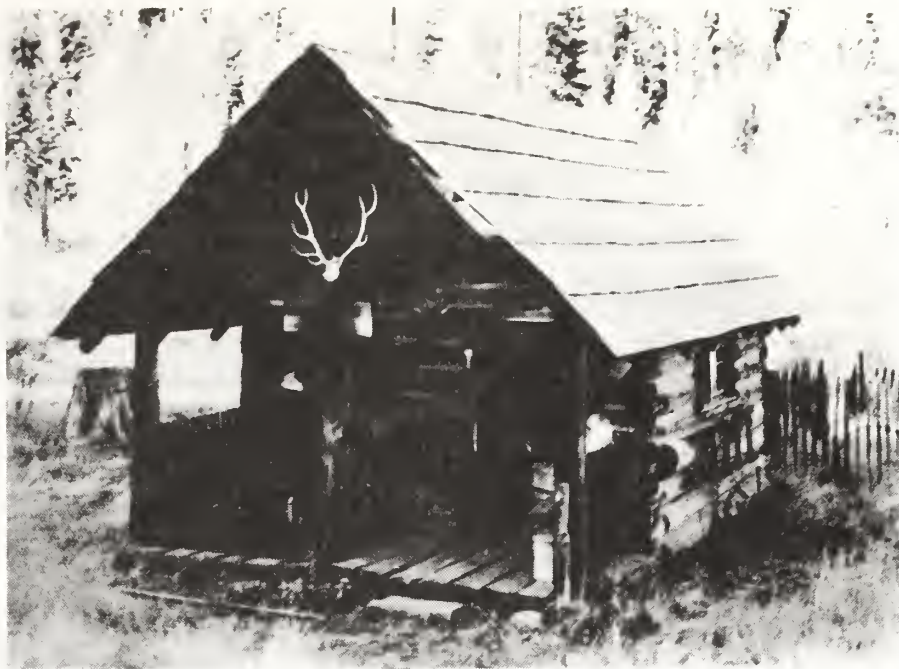

Fig. 32. Liz Creek cabin, Clearwater National Forest, Idaho (from Gerald Franc).



Fig. 33. Indian Creek Guard Station, Challis National Forest, Idaho (from Jerry Wylie).

## IX. SUMMARY

I have attempted in this report to document the existence of a previously unknown cabin type, and to find for this type a place in the overall development of American log technology. While research in the eastern United States has yielded several excellent studies about log construction and vernacular traditions in architecture, the western United States has received little of this attention. Perhaps this lack of attention is attributable to the fact that Western structures are not as old as their Eastern counterparts, a condition that can prove to be an advantage in that more examples remain, thus making more accurate studies possible. At this time, the Rocky Mountain cabin is the last documented cabin type to appear in North America (early examples date from about 1890, with the height of construction coming in the 1920's). As the construction of vernacular structures continues to decline, it may well be the last definable type on this continent.

This limited study has shown that the concept used for the East of defining culture areas to explain vernacular diversity (and similarity) is not valid for the architecture of the Rocky Mountain West. The same processes appear to have been at work in both areas, but at different stages of development. Rocky Mountain construction began bringing in types that originated elsewhere (Eastern cabin types, the Anglo-Western, European types), and by builders experimenting with variations and recombinations that might better suit



the local climatic conditions. From these trials, a new type, the Rocky Mountain cabin, came into being and began to be duplicated throughout the region.

Although built with common attributes over a fairly limited geographic area, the RMC never experienced a standardization of form. No "culture areas" can be defined in the Rockies due to the diversity and temporary nature of settlement patterns. The termination point for the construction of vernacular forms is also not as well-defined in the Rocky Mountain region as in the East. The period between World War I and World War II saw a transition from vernacular to popular construction in Middle Virginia (Glassie 1975:57). This termination date probably holds true for most of the East. In the Rockies, however, popular forms appear almost from the beginning of settlement in the cities, and vernacular forms still continue to be constructed in rural areas, although their numbers have decreased.

The last decade has seen a renaissance in log construction throughout the country, the Rocky Mountain region in particular. Some of these are cabins traditional in notching and plan, others of modern design with complex notching and contemporary plan (Figures 34 and 35). These structures, with few possible exceptions, represent the popular culture's rendition of vernacular styles and are not themselves folk in nature. This upsurge in log building has brought renewed interest in the cabins of America's past and will hopefully aid in the continued examination of log construction in the United States. Much work remains to be done before the roles of the Anglo-



Fig. 34. Brink Realty Office, Stanley, Idaho (from Jerry Wylie).

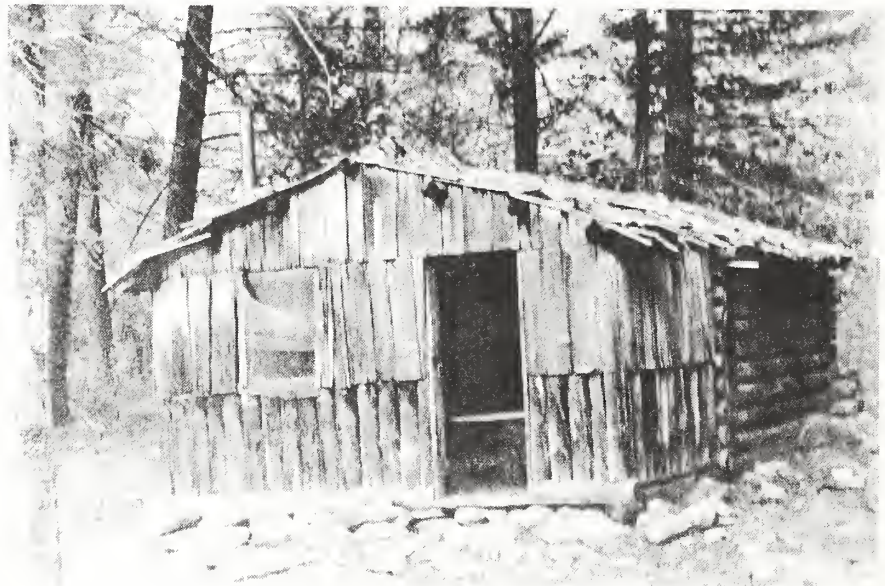

Fig. 35. Bump's cabin, Payette National Forest, Idaho. Gable extension has been walled to make a second full room (from Carrey and Conley, 1977).

Western and Rocky Mountain cabin in the settlement of the Rocky Mountain region can be fully understood. As these cabins continue to fall, unrecorded, this task becomes more urgent.

It should also be the goal of those studying western cabins to apply their findings to theories about vernacular construction. This approach will involve an interdisciplinary effort including architecture, history, geography, and anthropology. Archaeology will become an increasingly important tool as standing structures disappear. I have attempted to incorporate into this report procedures used in these different disciplines. I am hopeful the result of this study has been not only an identification of types, but also an attempt to understand man's dual natures of constancy and innovation.

## NOTES

1. The only Eastern vernacular structure that typically possesses a foreward-facing gable is the Shotgun house of Louisiana, described by Fred Kniffen to be a long, narrow house one room width and from one to three rooms deep. A front porch formed by either a gable extension or by a shed addition is very common (Kniffen 1936:186).
2. One of the best sources about the distribution of log construction methods is provided by Kniffen and Glassie (1966:61). They report square notching to be a corner timbering form developed by English immigrants to America, used instead of the German "V" notch. Square notching is the commonist form of corner timbering east of the Blue Ridge, particularly in the Virginia Piedmont (Kniffen and Glassie 1966:63).
3. The presence of immigrants from Germany and Sweden, along with natives of the southeastern United States living in the Rocky Mountain region can be documented. The earliest complete census for the State of Idaho from the year 1900 reports an overall population of 57,666. Four-thousand, nine-hundred and fifteen or 8.5 percent of these were originally from Germany or Sweden, and 7,542 (13 percent) reported themselves to be natives of the Southeastern United States.

## REFERENCES CITED

- Barnett, Homer  
 1953 Innovation. New York: MacGraw Hill.
- Bealer, Alex, and John O Ellis  
 1978 The Log Cabin. Barre, MA: Barre Publishing
- Beard, D. C.  
 1914 Shelter, Shacks, and Shanties. New York: Charles Scribner's Sons.
- Browne, J. Ross  
 1861 "A Peep at Washoe." New Harper's Monthly Magazine 22:155-156.
- Carrey, John, and Cort Conley  
 1977 A Guide to the Middle Fork of the Salmon and the Sheepeater War. Riggins, ID: Backeddy Books.
- Clampitt, John W.  
 1889 Echoes from the Rocky Mountains. Chicago: Belford, Clark, and Company.
- De Visser, John, and Harold Kalman  
 1976 Pioneer Churches. New York: W. W. Norton and Company.
- Farnham, Thomas T.  
 1843 "Travels in the Great Western Prairies, the Anahuac and the Rocky Mountains, and the Oregon Territory." In Early Western Travels, 1748-1846, volume 28, edited by Ruben Gold Thwaites. Cleveland: Arthur H. Clark.
- Fickes, C. P., editor  
 1935 "Construction and Maintenance of Forest Improvements." Region 1 Handbook, USDA Forest Service.
- 1945 "Building with Logs." USDA Forest Service Miscellaneous Publication No. 579.
- Glassie, Henry  
 1963 "The Appalachian Log Cabin." Mountain Life and Work 39(4):5-14.
- 1968 "The Types of the Southern Mountain Cabin." Appendix C of The Study of American Folklore, by Jan Bruvand. New York: W. W. Norton.
- 1968 Pattern of the Material Folk Culture of the Eastern United States. Philadelphia: University of Pennsylvania Press.

- 1975 Folk Housing in Middle Virginia. Knoxville: University of Tennessee Press.
- Gimbutas, Margia  
 1956 The Prehistory of Eastern Europe. Cambridge: The Peabody Museum.
- 1963 The Balts. London: Thames and Hudson.
- Gritzner, Charles F.  
 1971 "Log Housing in New Mexico." Pioneer America. 3(2):60-63
- Hartung, John  
 1978 "Documentation of the Historical Resources in the Idaho Primitive Area, Big Creek Drainage." Unpublished Master's thesis, University of Idaho, Moscow.
- Hatton, Raymond R.  
 1977 The High Desert of Central Oregon. Portland: Binford and Mort.
- Hawgood, John A.  
 1967 America's Western Frontiers. New York: Alfred A. Knopf.
- Hult, Ruby E.  
 1952 Steamboats in the Timber. Caldwell, ID: The Caxton Printers.
- Hunt, Charles B.  
 1967 Physiogeography of the United States. San Francisco: W. H. Freeman and Company.
- Irving, Washington  
 1837 The Adventures of Captain Bonneville. Boston: Thwayne Publishers.
- Johansen, Dorothy O.  
 1967 Empire of the Columbia. New York: Harper and Row.
- Jordan, Terry  
 1978 Texas Log Buildings: A Folk Architecture. Austin: University of Texas Press. Kniffen, Fred.
- 1935 "Louisiana House Types." Annals of the Association of American Geographers 26(4):179-193.
- 1965 "Folk Housing: Key to Diffusion." Annals of the Association of American Geographers 55(4):549-576.
- Kniffen, Fred, and Henry Glassie  
 1966 "Building With Wood in the Eastern United States: A Time-Place Perspective." Geographical Review 56(1): 40-66.

- Maholy-Nagy, Sibyl  
 1957 Native Genius in Anonymous Architecture in North America. New York: Schokin Books.
- Mercer, Eric  
 1975 English Vernacular Architecture. London: Royal Commission on Historical Documents.
- Merk, Frederick  
 1978 History of the Westward Movement. New York: Alfred A. Knopf.
- Murphy, Robert F., and Yoland Murphy  
 1960 "Shoshone Bannock Subsistence and Society." Anthropological Records 16(7):293-338.
- Richards, J. M.  
 1978 800 Years of Finnish Architecture. London: David and Charles.
- Ridge, Martin, and Ray A. Billington, editors  
 1969 America's Frontier Story. New York: Holt Rinehart and Winston.
- Sappington, Robert Lee,  
 1981 "The Archaeology of the Lydle Gulch Site" (10-AA-72): prehistoric occupation of the Boise River Canyon in southwestern Idaho. University of Idaho Anthropological Research Manuscript Series (in press), Moscow.
- Shurtleff, Harold R.  
 1939 The Log Cabin Myth: A Study of Early Dwellings of the English Colonies in North America. Cambridge: Harvard University Press.
- Townsend, John K.  
 1906 Narrative of a journey across the Rocky Mountains to the Columbia River, and a visit to the Sandwich Islands, and Chile; with a scientific appendix. In Early Western Travels 1748-1846, volume 21, edited by Ruben Gold Thwaites. Cleveland: Arthur H. Clark.
- Ubbelonde, Carl, Maxine Benson, and Dwane Smith  
 1972 A Colorado History. Boulder: Pruett Publishing Company.
- Welsch, Roger L.  
 1980 Nebraska Log Construction: Momentum in Tradition. Nebraska History, Fall:310-355.
- Weslager, C. A.  
 1971 The Log Cabin in America. Rutgers University Press.





LOG CABIN TECHNOLOGY AND TYPOLOGY  
By  
Mary Wilson

USDA Forest Service  
Intermountain Region  
1984



## TABLE OF CONTENTS

	<u>Page</u>
1. INTRODUCTION . . . . .	1
2. CORNER JOINTS . . . . .	1
True Notching, Types Common . . . . .	3
True Notching, Types Less Common . . . . .	8
Other Log Construction Methods . . . . .	10
3. FLOOR PLANS . . . . .	12
4. ROOF AND WINDOW CONSTRUCTION . . . . .	18
REFERENCES CITED . . . . .	21



## 1. INTRODUCTION

Log construction first began in the Near East, spreading across Europe as a part of the Neolithic culture complex (Kniffen and Glassie 1966). This construction method was first introduced in North America by Swedish emigrants about 1638. It was, however, not until 1671 that German emigrants began to popularize log construction in the New York (Shurtleff 1939:176-178). This group, popularly known as the Pennsylvania Dutch, along with large numbers of Scotch-Irish settlers, helped to make logs the dominant construction form for most of the eastern United States south of New England by the end of the 16th century (Kniffen 1965:561).

The following paper presents a brief summary of basic definitions for the components of log construction, an explanation of the way these components can be assembled, and floor plans most common to log structures built in the United States. The aim is present an easy-to-follow reference source for those interested in log technology, with particular emphasis given examples from the western United States.

## 2. CORNER JOINTS

The following diagrams (Figure 1) shows the basic terminology given to logs used in construction. The first part (Figure 1a to g) deals with the parts of a notched log. The second part (Figure 1h to m) deals with the exterior form of the log, which may be altered either prior to or after the construction of the log structure. Logs left in the round may also show variation by either being peeled for having bark left on the

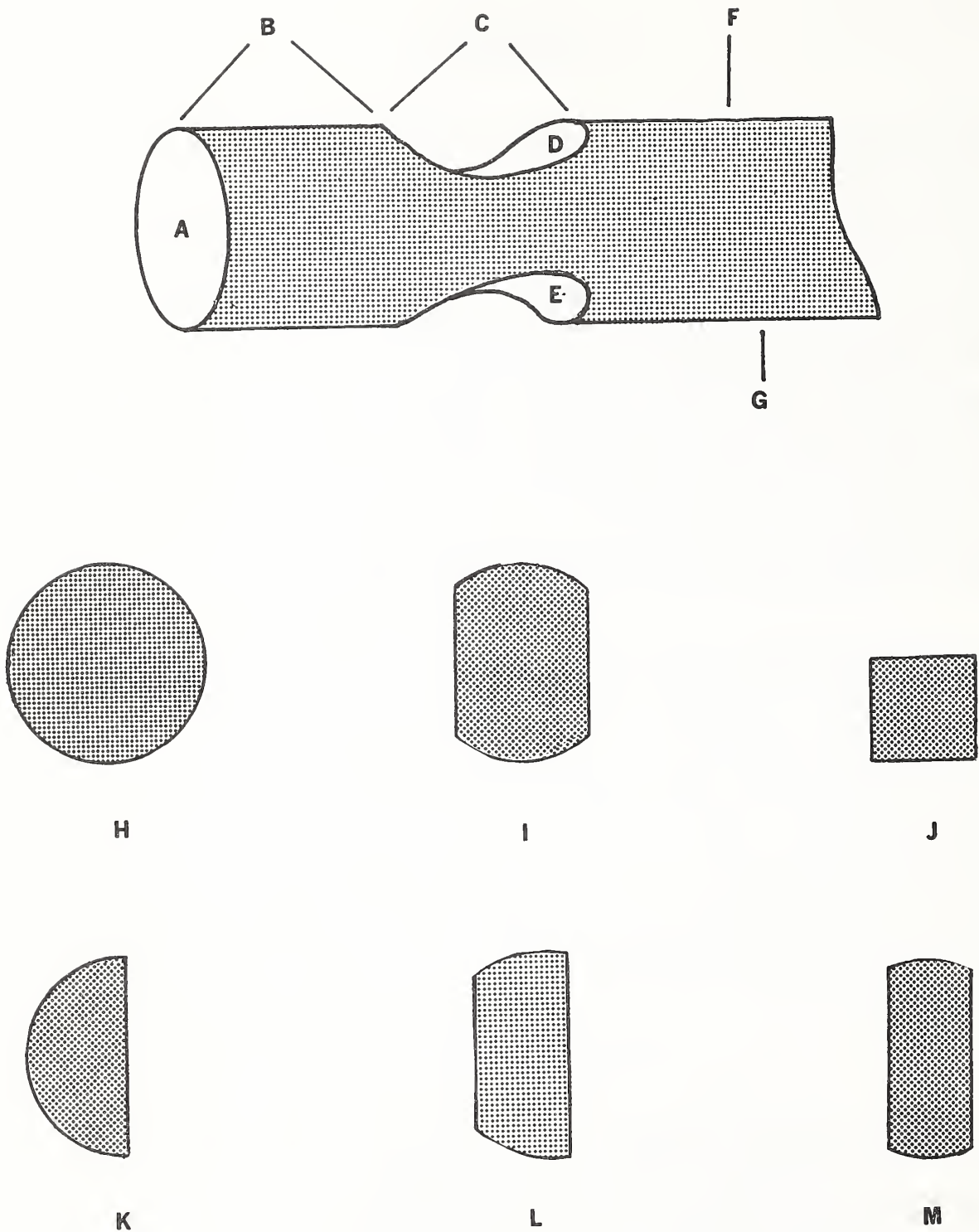

Fig. 1. Log Terminology: a, crown; b, head; c, neck; d, dorsal notch; e, ventral notch; f, dorsal side; g, ventral side; h, round; i, round hewn; j, square hewn; k, half log; l, hewn half log; m, planked (from Jordan 1978).

exterior surface of the logs in the finished structure. Figure 2 provides structural terminology used when discussing the parts of a log structure.

### True Notching Types, Common

Saddle Notch: The simplest notching methods, it is almost always used on round logs which, for maximum tightness at the corner joints, should extend beyond the plane of the wall. The saddle is probably the most ancient form of corner notching. While replaced in popular usage by more complex notches during much of the 18th and 19th centuries, the saddle again became the most commonly used notch for much of the United States during the 20th century (Figure 3a).

Three general variations exist; notches can occur on the upper, the lower, or on both sides of a log. Lower notching only is the most effective for shedding water and is the most common variety. Other names for this notch include groove-joint with round notch (Erixon 1937), and coping and cutting (Aldritch 1934).

Square Notch: This method is simple to execute, but does not interlock the logs as do most other types. This problem is often remedied by the addition of pegs or metal spikes. While square notching seems to have originated in English areas of Virginia during the 18th century, it is commonly found today in 19th and 20th century structures from the western United States. It can be found on hewn logs or rounded logs squared only on the ends (Figure 3b). Other names for the square notch

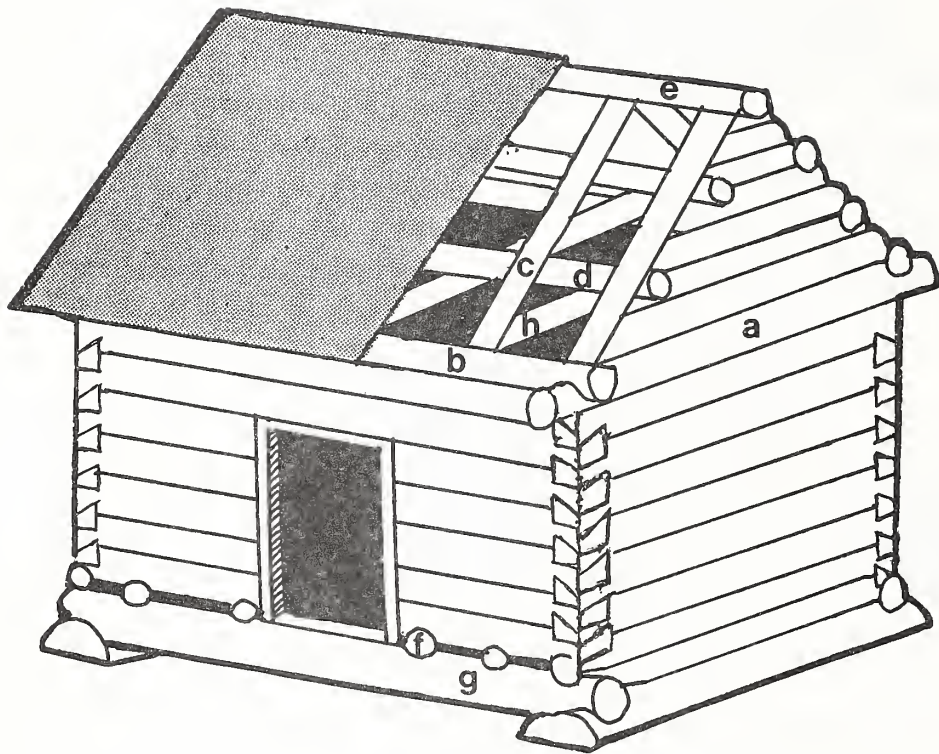

Fig. 2. Structural terminology: *a*, eave beam; *b*, plate log; *c*, rafter; *d*, purlin; *e*, ridgepole; *f*, joist; *g*, sill log; and *h*, tie beam (Hutslar, 1974).



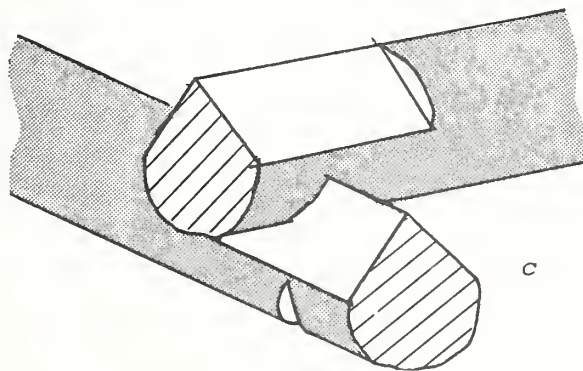
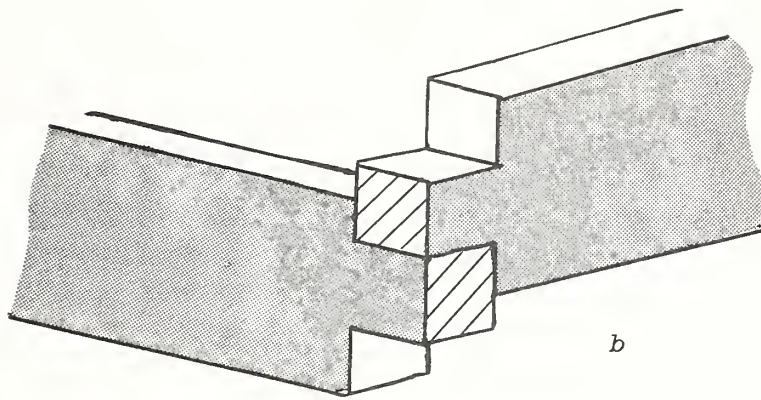
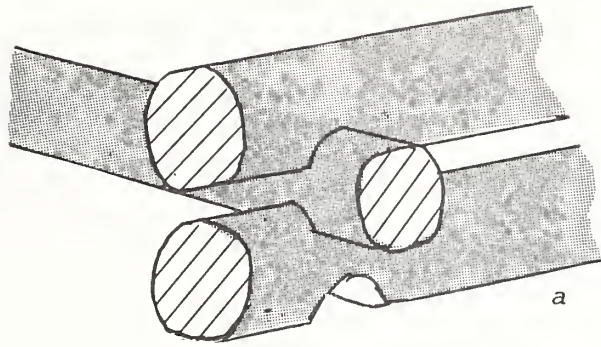

Fig. 3. Notches: a, saddle; b, square; and c, "v" notch.

include lapped joint (Mackie 1972), corner joint (Erixon 1937), and full lap (Hutslar 1972).

Full Dovetail Notch: This is one of the most complicated corner timbering methods requiring considerable skill to execute. Logs are locked in both directions producing a box-like corner; the logs are usually hewn, or at least squared at the ends. The dovetail was most popular in the eastern United States in the late 18th century (Figure 4a). It is also called chamber and notched (Sloane 1964).

Half Dovetail Notch: While probably a simplification of the full dovetail notch, this corner timbering method was easier to execute and was far more popular. This method was commonly used throughout the southern and central United States during the 19th century. Along with the saddle notch, this type is described in 20th century Forest Service building manuals, and can be found in Forest Service structures from the western United States (Figure 4b).

"V" Notch: This notch is executed by making V-notch cut into the bottom of an upper log which fits into the pointed crown of a lower log. The cross-section of a rounded log appears pear-shaped when a "V" joint is used, a hewn log takes on a gabled appearance. This notch is usually found in 18th century structures in the eastern United States, and can be found in late 19th century structures in the West (Figure 3c). Other names for this notching type include steeple notch (Hutslar 1972), saddle (used by most Canadian authors), saddle and rider (Sultz 1964), saddle in notch (Aldritch 1934), groove joint (Erixon 1937), dog collar (Karni and Levin 1972), and sharp notch (Sloane 1964).

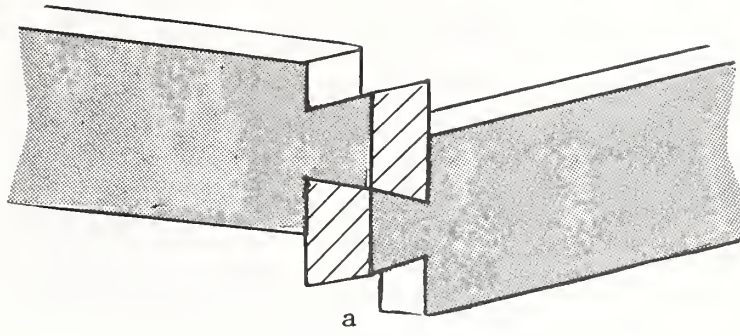

a

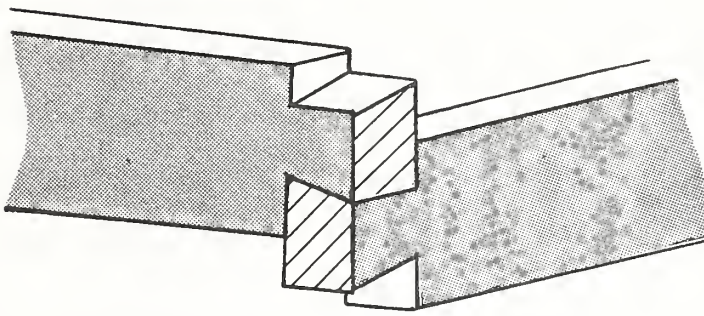

b

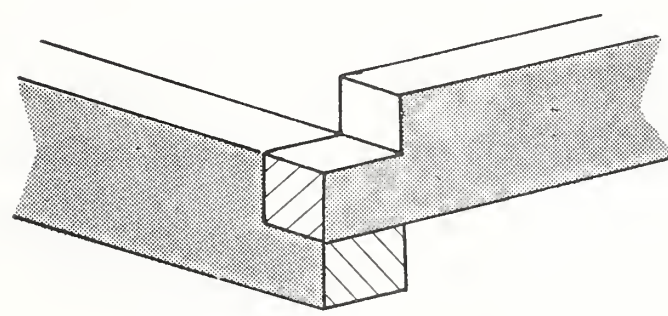

c

Fig. 4. Notches: a, Full dovetail; b, Half dovetail; c, half notch.

## True Notching Types, Less Common

Half Notch: A variation of the square notch, the half notch is sometimes executed by itself, but more often occurs in conjunction with square notching to help reposition and straighten the rows of horizontal logs (Figure 4c) (Kniffen and Glassie 1966). Also called tenant corner (Sultz 1964 and 1969), corner joint (Erixon 1937), half lap (Hutslar 1972), and square notch (Sloane 1964).

Double Lock. This form of notching is common to Sweden and other parts of Scandinavia and can be found in the upper Great Lakes region of North America and occasionally in other isolated areas settled by Scandinavian emigrants. While not common for cabin construction, this is the notching form used in "Lincoln Logs" (Figure 5a) (Kniffen and Glassie 1966). Also called lip joint (Erixon 1937), full double joint (Gritzner 1969), and egg crate (Mackie 1972).

Single Lock: This variation of the double lock notch has one large notch cut in the bottom of the logs instead of smaller notches cut on both the top and bottom. Both single and double lock notches appear very similar from outside examination (Figure 4b) (Kniffen and Glassie 1966). Also called common block (Karni and Levin 1972), lipped joint (Erixon 1937), and half double (Gritzner 1969).

Diamond Notch: A complicated design, the diamond notch involves cutting a "V" notch in both the top and bottom of a log. It is quite rare (Figure 5c) (Kniffen and Glassie 1966, Weslager 1969).

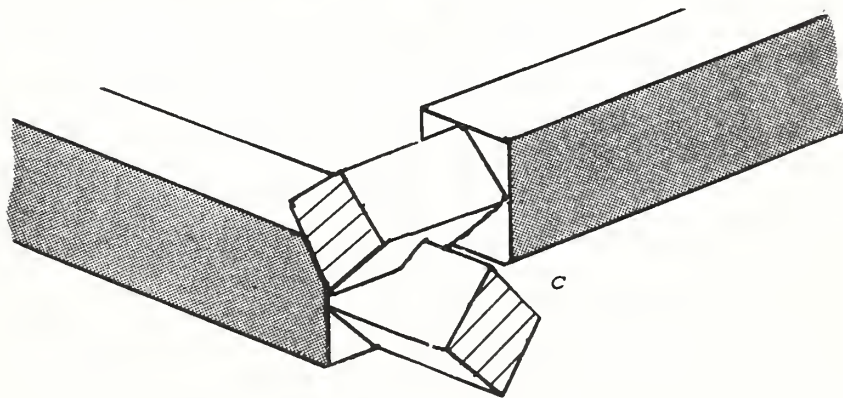
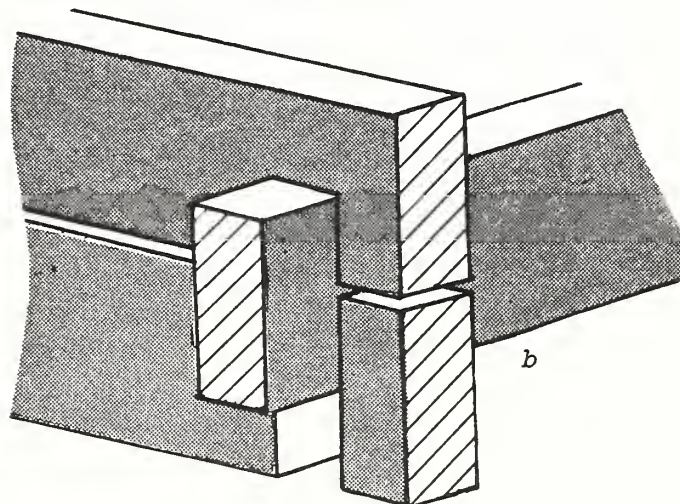
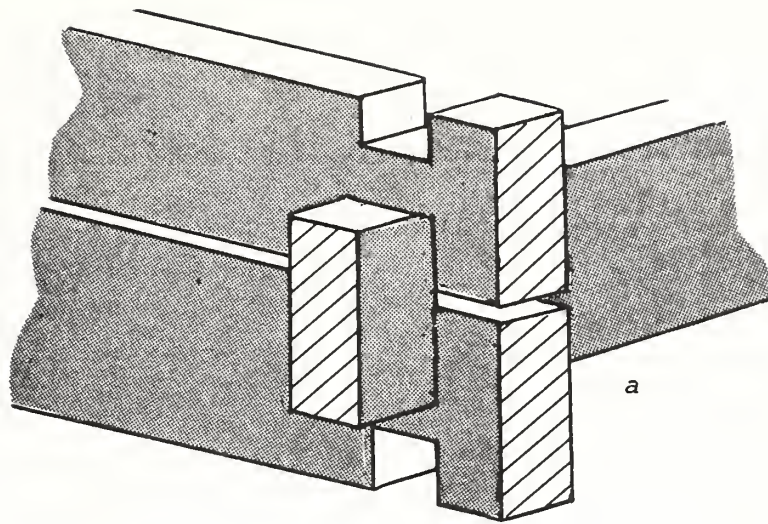

Fig. 5. Less common notches: a, double lock; b, single lock; and c, diamond notch.

## Other Log Construction Methods

False Notching: In this construction technique, logs are laid in even tiers which do not effectively interlock with those immediately above or below (Figures 6a and b). This method probably originated as an English interpretation of true corner timbering introduced to America by the Germans and Swedes. Recognized types include the butt joint (commonly used in modern cabin manufacture) (Figure 6c), the lapped or rebated joint (Figure 6d), and the tongue and groove joint, an exaggerated form of a square notch (Kniffen and Glassie 1966).

Mortise and Tenon: Also known as piece-sur-piece, this method can be used with logs or planks. Vertically notched horizontal timbers are placed into the grooves of vertical timbers set at regular intervals. While this requires more time and care than most construction methods, it allows the use of shorter timbers and puts no restrictions on the size of the building. Most common in areas of French settlement, this method is still used today in remote parts of Canada (Figure 7a) (Attebery 1976, Hutslar 1972, and Kniffen and Glassie 1966).

Box Corner: This technique involves the use of heavy planks to abut the ends of horizontal logs at the corners, usually spiked or pegged into place. This may be left uncovered giving the corner an indented "V" appearance (Figure 7b), or be covered by two or more additional boards to form the more standard squared corner appearance (Figure 7c) (Attebery 1976, Kniffen and Glassie 1966). Other variations include the use of a

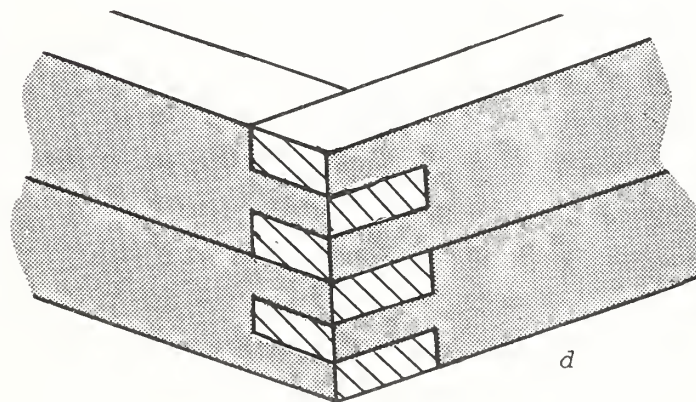
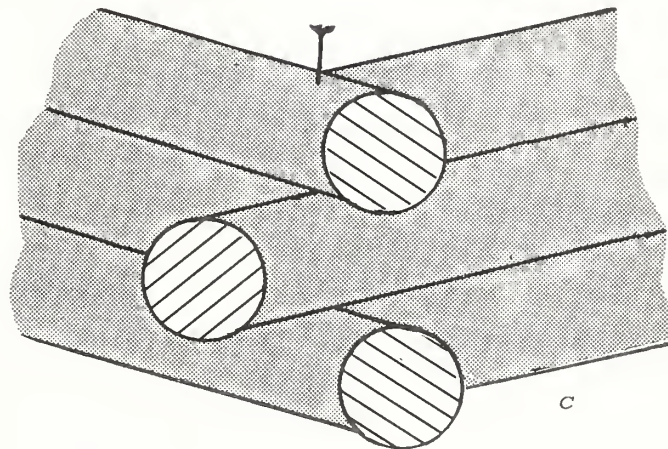
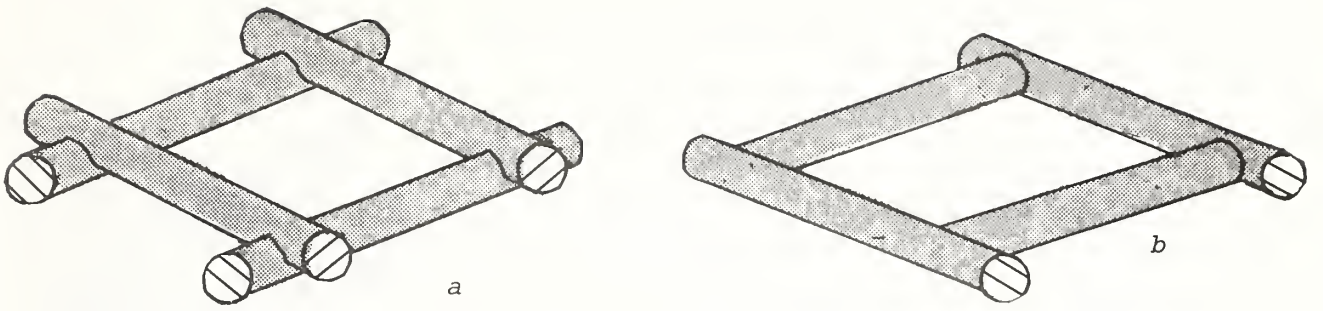

Fig. 6 . Corner terminology: *a*, true notching; *b*, false notching; *c*, butt joint; and *d*, lapped or rebated joint.

vertical log to fill this outside corner (Figure 7d) or a single board to abut the horizontal ends (Figure 7e).

Post on Sill: The contemporary form of the ancient stockade construction (poteaux en terre) usually appears as vertical posts attached to a horizontal board. If spaces remain between logs, these are filled with chinking or wook strips (Figure 7f).

### 3. FLOOR PLANS

Log structures, while quite usable in specific dimensions, can usually be grouped into a few basic floor plans. This information can be important because floor plans generally show less variation through time than do other architectural elements. Local conditions may necessitate the use of unfamiliar construction materials, but structures still may be laid out in a traditional way. Because of this, a structure's plan has been successfully used in some areas as a guide to its builders ethnic heritage. The majority of log structures constructed in the United States are single or double pen in size, so these plans are given the most emphasis.

In the following figures, a broken line indicates the position of ridgepole. The positions of windows and doors are not included due to their variability; however, a door usually occurs in the structure's front wall (the wall toward the bottom of the page in the following drawings).



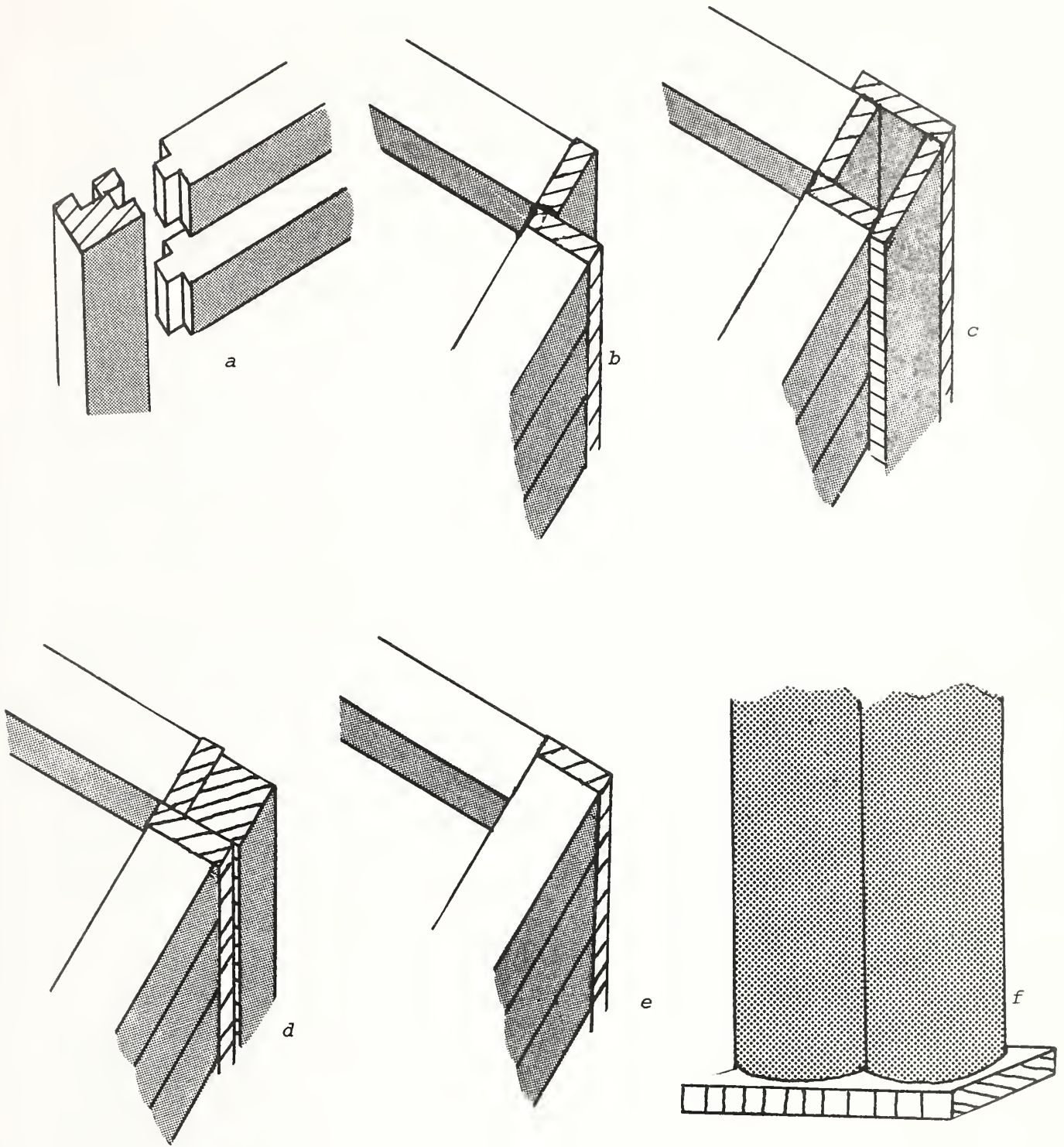

Fig. 7. Other corner-timbering methods: a, mortise and tenon; b, hog trough corner; c, covered box corner; d, corner post; e, lapped box corner; and f, post on board.

Single Pen: The great majority of single pen dwellings (those constructed as a single four-sided unit) belong to one of four types. A square single pen dwelling has four walls of equal or near equal dimensions (usually 16 feet to 18 feet per side). A single door faces forward in a nongabled wall. Also common is a single chimney centered along a gabled wall. While almost never reaching two full stories, a loft is common, reached through a steep corner stairwell. This floor plan appears to be British in origin, first appearing in log structures east of the Appalachians in the 18th century. Through time, this plan has become popular in cabin construction throughout the United States and can be found in most geographic areas (Figure 8a).

Also common throughout the United States is the rectangular single pen, in which the structure's width is greater than its depth. The dwelling may be single large room or is frequently divided into two rooms of unequal size by an interior partition. Like the square pen, the rectangular cabin may be up to one and a half stories in height. The origin of this plan is traced to Scotch-Irish emigrants, occurring most frequently in the Upland South and Midwest (Figure 8b).

From the Great Plains and into the Far West, the single pen most commonly appears as a front-gabled structure with a single door in the front wall. In the "Anglo-western" cabin, a manufactured iron stove usually replaces the traditional chimney. This cabin type appears as a common dwelling type in the United States in the mid-19th century (Figure 8c).

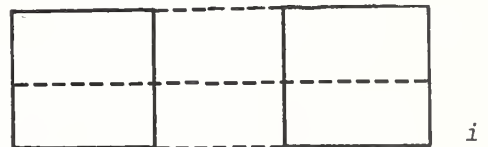
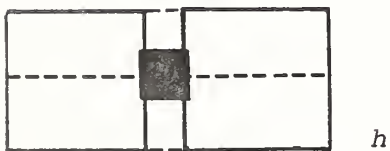
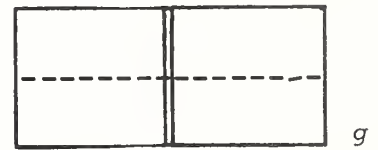
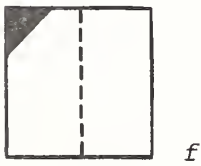
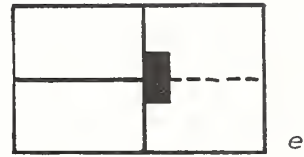
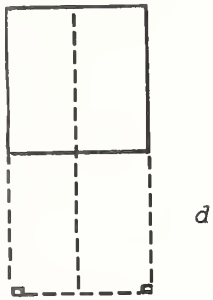
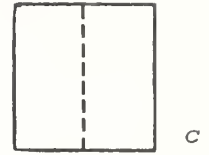
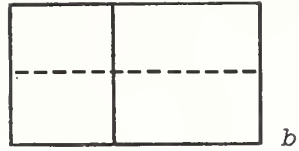
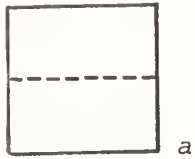

Fig. 8. Floor plans: *a*, rectangular single pen; *b*, square single; *c*, Anglo-Western cabin; *d*, Rocky Mountain cabin; *e*, central chimney house; *f*, Spanish-American; *g*, simple double pen; *h*, saddlebag; and *i*, dogtrot.

Other types of single pen structures can also be found, most reflecting ethnic or geographic diversity. The large central-chimney house usually reflects the builder's German heritage (Figure 8e). A front-gabled structure with a corner chimney is common in areas where the Spanish-American influence was strong (Figure 8f) (Glassie 1968, Jordan 1978, Gritzner 1969, Kniffen 1936, Welsch 1980, and Muckelroy 1974).

Double Pen: As the name implies, this group of structures is made up of dwellings constructed of two four-sided units that, while not usually joined, share a common roof. In the basic double pen, a side of the first pen abuts a side of the second pen along one of their gabled walls. This type is often called the "Cumberland House" denoting the geographic area of its greatest popularity (Figure 8g).

Two other types of double pen structures are popular in different parts of the country. In cooler climates, the central chimney or saddlebag structure can be found (Figure 8h). In more temperate or humid climates, the Dogtrot cabin shows popularity (Figure 8i).

Multiple Pens: Log structures of three or four pens do occur, but are far less common than one and two pen varieties. Most took form over time as additions were made to simpler structures. Names for these types reflect the overall form of the dwelling and the amount of space left between pens (Figure 9). Another very common way of adding onto a log building is the addition of a shed structure usually of framed wood and usually along a nongabled wall (Jordan 1978).

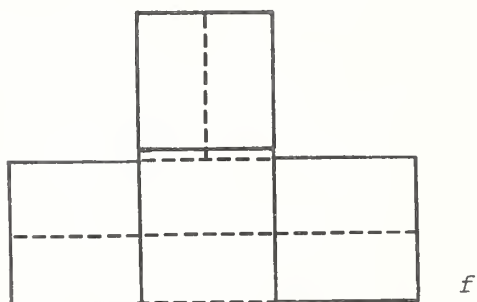
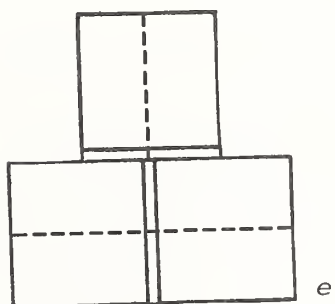
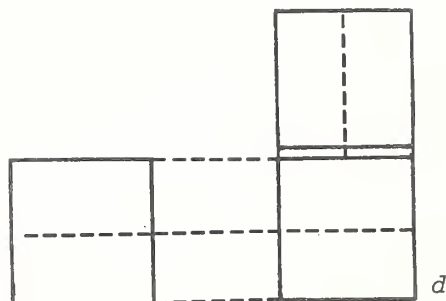
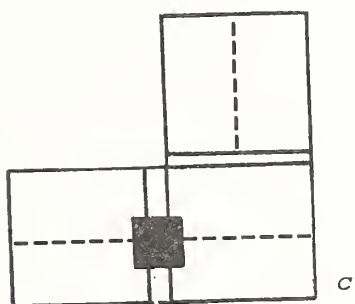
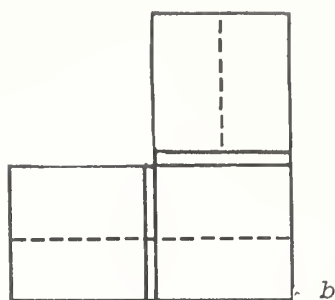
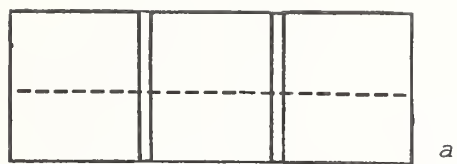

Fig. 9. More complex floor plans: a, linear triple pen; b, ell; c, saddlebag ell; d, dogtrot ell; e, "T"; and f, dogtrot "T" (Jordan, 1978).

#### 4. ROOF AND WINDOW CONSTRUCTION

Roofs: The following diagram on roof typology (Figure 10) illustrates the most common roof forms found on cabins in the United States. The vast majority of log structures built possess a simple gabled roof (Figure 10). Some variation exists, however, especially among Western structures. Other roof forms that can occur, but are not shown here, include circular, hexagonal (eight-sided), pyramidal (an equilateral hip-roofed structure), and a flat roof (no slope).

Roofing materials can be quite variable. Sometimes two or more materials were combined to cover a structure. If a structure was used for a number of years, it may have had different materials used at different times. Often, an old roof was left in place and new materials laid on top of it. Roofing materials that could be produced by the builder included split logs, split shakes, split shingles, sod, and thatched/straw. Where manufactured materials were available, roof can be found composed of sawed planks, plywood, asphalt shingles, tar paper, and tin.

Windows: Two primary window types can be found in 19th and 20th century vernacular construction, they are sash-type (Figure 11a) and casement-type (Figure 11b) windows. The principal difference lies in the method used to open the window. Sash-type windows slide open, either vertically or horizontally, along wooden grooves. Casement-type windows rotate open on hinges toward the interior or exterior of a structure. Much variation exists within both window types concerning overall window size and the number of glass panes. The basic terminology of window components is included in Figure 11.

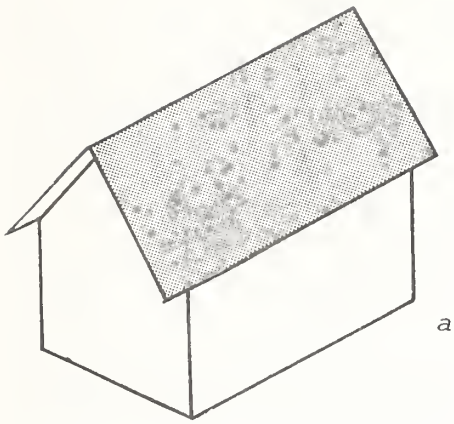

*a*

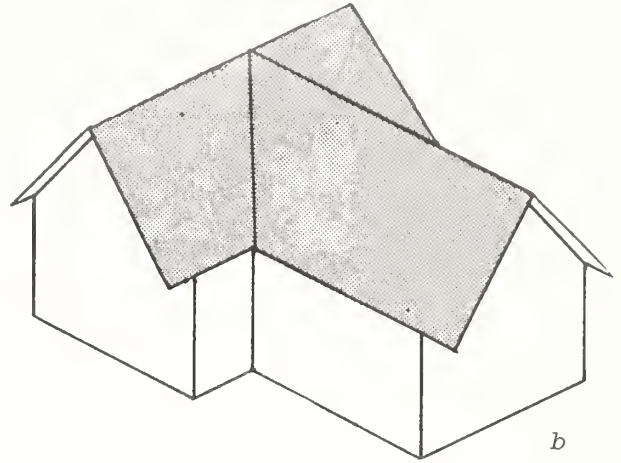

*b*

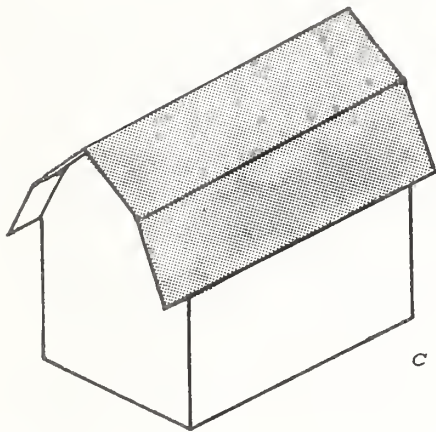

*c*

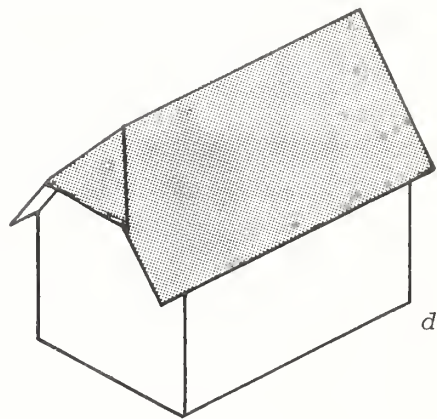

*d*

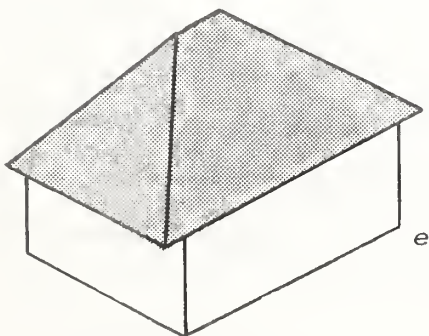

*e*

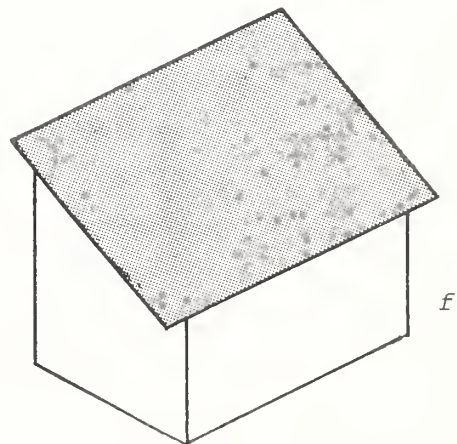

*f*

Fig. 10. Roof typology: *a*, simple gable; *b*, multiple gables; *c*, gambrel; *d*, jerkin head (clipped gable); *e*, hip roof; and *f*, shed roof.

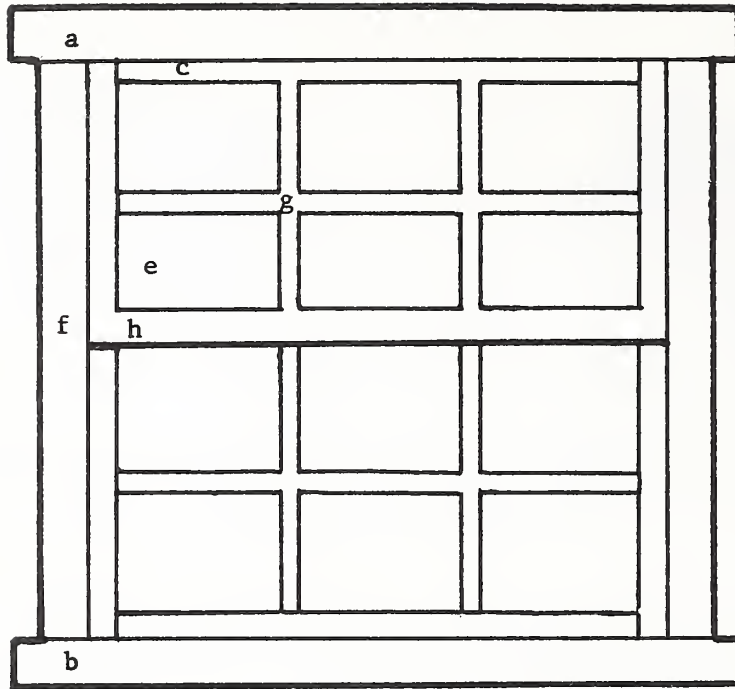

Sash-type window

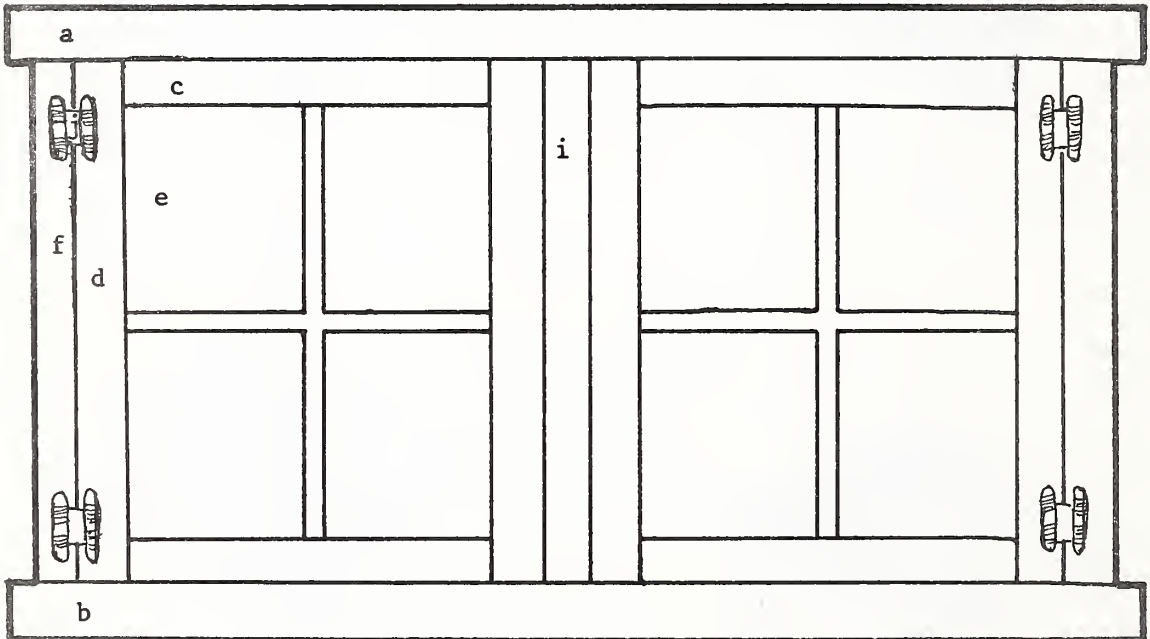

Casement-type Window

Fig. 11. Window typology: a, head; b, sill; c, rails; d, stiles; e, lights or panes; f, jambs; g, mutins; h, meeting rails (g and h on casement type only); i, mullion; j, hinges (i and j on casement type only).



## REFERENCES CITED

- Aldrich, Chilson D.  
1934 The Real Log Cabin. New York: Macmillan.
- Attebery, Jennifer Eastman  
1976 Log Construction in the Sawtooth Valley of Idaho. Pioneer America 8(1):36-46.
- Erixon, Sirgud  
1937 The North European Technique of Corner Timbering. Folkliv 1:56-68.
- Glassie, Henry, and Fred Kniffen  
1966 Building with Wood in the Eastern United States: A Time-Place Perspective. Geographical Review 56(1):40-56.
- Glassie, Henry  
1968 Pattern in the Material Folk Culture of the Eastern United States. Knoxville: University of Tennessee Press.
- Gritzner, Charles F.  
1969 Spanish Log Construction in New Mexico. Doctoral dissertation, Louisiana State University.
- Hutslar, Donald A., and Jean J. Hutslar  
1972 The Log Architecture of Ohio. Ohio History 80(3 and 4).
- Jordan, Terry  
1978 Texas Log Buildings: A Folk Architecture. Austin: University of Texas Press.
- Karni, Michael, and Robert Levin  
1972 Finnish Log Cabins in Minnesota. North West Architect (3):92-99.
- Kniffen, Fred  
1936 Louisiana House Types. Annals of the Association of American Geographers 26(4):179-193.  
1965 Folk Housing: A Key to Diffusion. Annals of Association of American Geographers 55(4):549-576.
- Kniffen, Fred, and Henry Glassie  
1966 Building with Wood in the Eastern United States. Geographical Review 56(1):40-56.
- Levin, Robert, and Michael Karni  
1972 Finnish Log Cabins in Minnesota. North West Architect (3)92-99.
- Mackie, B. Allen  
1972 Building with Logs. Prince George, BC: Hairy Woodpecker Press.

Muckelroy, Duncan C.

1974 Ranching History of the American West: Revitalized Through the Preservation of Its Architecture. Pioneer America 6(2):34-42.

Shurtleff, Harold R.

1939 The Log Cabin Myth: A Study of Early Dwellings of the English Colonies in North America. Cambridge: Harvard University Press.

Sloane, Eric

1964 A Museum of Early American Tools. New York: Funk and Wagnalls.

Sultz, Phillip W.

1964 From Sagebrush to Hay and Back Again. American West 1(1):20-30.

1969 Architectural Values of Early Frontier Log Structures. In Forms Upon the Frontier: Folklife and Folk Arts in the United States. Logan: Utah State University Press.

LOG CABIN BIBLIOGRAPHY  
By  
Mary Wilson

USDA Forest Service  
Intermountain Region  
1984



## INTRODUCTION

This partially annotated bibliography is not intended to be an exhaustive listing of works about log construction, but rather a representative sampling of existing publications. The 230+ listings are divided into six sections according to subject matter.

A special thanks for this bibliography to Jerry Wylie and Donald Hill for making accessible the sources they have gathered over the years about log construction.



TABLE OF CONTENTS

	<u>Page</u>
INTRODUCTION . . . . .	i
1. MAJOR INFORMATIONAL SOURCES . . . . .	1
<p>This section includes works that can at this time be considered the most important because of their methodology, typology, or just overall completeness.</p>	
2. THEORETICALLY VALUABLE SOURCES . . . . .	3
<p>This section includes works that form the basis for present methodology in this field. Perspectives include those of geography, anthropology, history, and architecture.</p>	
3. GENERAL SOURCES . . . . .	4
<p>Works in this section are primarily popular works, either very general in nature or part of a study emphasizing other subject matter.</p>	
4. REGIONAL STUDIES . . . . .	7
A. The Western United States . . . . .	7
B. The Midwest and Plains States . . . . .	10
C. The Eastern and Southern United States . . . . .	12
D. Outside the United States . . . . .	16
5. LOG CABIN CONSTRUCTION, MAINTENANCE, AND RESTORATION . . . . .	19
6. BIBLIOGRAPHIES . . . . .	22





Part 1 - Major Informational Sources

Bealer, A. W., and J. O. Ellis

1978 The log cabin: homes of the North American wilderness. NY: Clarkston N. Potter, Inc.

A nontechnical look at the log cabin in America, from colonial times to the present. Very well illustrated.

Beard, D. C.

1914 Shelters, shacks, and shanties. NY: Charles Scribner's Sons.

Contains numerous sketches of log, pole, and timber construction. A very early look at this kind of construction.

Dunfield, John D.

1974 Log cabin construction. (unpublished paper) Ottawa, Ontario.

Erixon, Sirgud

1937 The North European technique of corner timbering. Folkliv, 1:56-68.

A major work detailing Northern European notching - techniques, distributions, and change over time.

Fickes, C. P., and W. E. Crolen

1957 Building with logs. U.S. Forest Service, misc. publication No. 579.

A primer for 20th century log cabin construction with excellent line drawings and photos.

Jordan, Terry

1978 Texas log buildings: a folk architecture. Austin: Univ. of Texas Press.

A look at Texas log cabins and their Germanic origins, as well as a study in methodology.

Kniffen, Fred B.

1936 Louisiana house types. Annals of the Association of American Geographers 26:179-193.

Important as an informational source for floor-plan terminology, applicable for most of the United States.

Kniffen, Fred B., and Henry Glassie

1966 Building with wood in the eastern United States: a time-place perspective. Geographical Review 56(1):40-66.

Probably the most important brief publication on cabin technology, it attempts to describe and interpret the establishment and westward movement of cabin technology across eastern North America.

- 1969      On corner-timbering. Pioneer America: 1(1):1-4.
- Descriptions and illustrations of all major notching types, with discussions about their origins, evolution, and relative merits.
- Mackie, B. Allen
- 1972      Building with logs. Prince George, B.C.: Hairy Woodpecker Pub.
- Mostly a "how-to" manual, but provides information on French and Canadian building techniques.
- 1977      Notches of all kinds. Prince George, B.C.: Hairy Woodpecker Pub.
- Rock, Jim
- 1980      Log cabins: horizontal log construction. Siskiyou County Historical Society Technical Papers.
- Written for use as a training guide for Klamath National Forest.
- Stickley, Gustav
- 1912      Architectural development of the log cabin in America. New York: The Craftsman Pub. Co.
- Swanson, William
- 1948      Log Cabins. New York: The Macmillan Company.
- Weslager, C. A.
- 1969      The log cabin in America. Rutgers University Press.
- One of the most significant and thorough books on the subject: includes history, typology, illustrations.

Part 2 - Theoretically Valuable Sources

Barnett, Homer

1953 Innovation. New York: MacGraw Hill.

An overlooked but important source in the analysis of change within culture. His theories are very applicable to vernacular architecture.

Glassie, Henry

1968 Pattern in the material folk culture of the eastern United States. Philadelphia: University of Pennsylvania Press.

Defines and examines vernacular architecture in the eastern United States, with an emphasis on origins and mechanisms for change.

1975 Folk housing in middle Virginia. Knoxville: University of Tennessee Press.

Probably the most detailed study of a vernacular architecture in existence. Looks at changes in typology over a 200-year period in the architecture of middle Virginia. Study includes both log and frame structures.

Kniffen, Fred B.

1965 Folk housing: a key to diffusion. Annals of the Association of American Geographers 55(4): 549-577.

A geographer's view of vernacular types. It includes a look at notching and cabin types (including some front-gabled varieties) and traces the western diffusion of these variables (into the Midwest only).

Meyer, Douglas K.

1975 Diffusion of the Upland South folk housing into the Shawnee Hills of southern Illinois. Pioneer American 7(2): 56-66.

A test of Glassie's theories about changes and diffusion as put forth in his Middle Virginia book.

Roberts, Warren E.

1972 Folk architecture in context: the folk museum. Proceedings of the Pioneer American Society 1:34-50.

Shurtleff, Harold R.

1939 The log cabin myth: a study of early dwellings of the English colonists in North America. Cambridge: Harvard University Press.

A separation of fact from fiction in the early architecture and materials of North American colonists; very good source for the historical background of log housing in North America.

Part 3 - General Sources

(The following publications are not directly written about log construction, but do include some cabin information, or else are about cabins, but of a very general nature.)

Aldrich, Chilson D.

1934 The real log cabin. New York: Macmillan Co.

Brochner, George

1913 The revival of the log cabin. New York: House and Garden.

Bruyere, C., and Bob Bruyere

1975 In harmony with nature. New York: Drake Publishers, Inc.

1976 Country comforts. New York: Drake Publishers, Inc.

Fife, Austin

1957 Folklore of material culture on the Rocky Mountain frontier.  
Arizona Quarterly 13: 104-110.

Gould, Mary Earl

1965 Early American life: households in America (1620-1850).  
Rutland, Vermont: Tuttle Publishers.

Graves, Richard H.

1952 Bush hutmaking: thatched huts, rammed earth, log cabins. Sydney:  
J. M. Graves (distributed via Shakespeare Press).

Guidoni, Enrico

1977 Primitive architecture. New York: H. N. Abrahams.

Interesting cross-cultural look at vernacular building traditions.

Herring, Ethel

1976 Echos of a log cabin. Winston-Salem, N.C.: Hunter Publishers.

Hoover, Helen

1969 A place in the woods. New York: Alfhred A. Knopf.

Karasz, I Lowka

1928 Log house in good taste. House Beautiful 64: July issue.

Kemp, Oliver

1908 Wilderness homes: a book of log cabins. New York: The Outing  
Publishing Co. (2nd ed., 1911).

Klammer, Paul W.

1963 Building with logs. Gopher Historian, Fall: St. Paul, Minn.

- Labastville, Anne  
 1976 Woodswoman. New York: E. P. Dutton and Co.
- Mercer, H. C.  
 1923 The dating of old homes. Doylestown, Pa.: Bucks County Historical Society Papers, Vol. 5.  
 1975 Ancient carpenter's tools. Doylestown, Pa.: Bucks County Historical Society (reprint).
- Morrison, Hugh  
 1952 Early American architecture: colonial to national period. Toronto: Oxford University Press.
- Mould, Jack  
 1976 Stumpfarms and broadaxes. Seattle, Wash.: Hancock House.
- Newton, Janet Foster  
 1944 Log cabin - or frame? Antiques Magazine 46: November.  
 1977 Log cabins as public occasions; Annals of the Association of American Geographers: September.
- Orians, G. Harrison  
 1955 My life in a log house; Northwest Ohio Quarterly 27: Fall.
- Owsley, Frank  
 1949 Plain folk of the old South. Baton Rouge: Louisiana State University Press.
- Peterson, Charles E.  
 1976 Building early America. Radnor, Pa.: Chilton Book Company.
- Kildare, Maurice  
 1967 Old cabin corners; Relics, fall issue: 16-18.  
 Gives some unique layman's terminology for notch names; shows some of the variation that exists in western building types.  
 1970 Cabins west; Relics 3(5): 6-9, 28-29.
- Robinson, Captain S.  
 1927 The manner of the backwoods; House and Garden Magazine: May.
- Rustrum, Calvin  
 1961 The wilderness cabin. New York: Macmillan Co.  
 A general overview of cabin and adobe techniques and variations.
- Sale, Edith Tunis  
 1929 A little cabin of logs; House Beautiful 65: May.

- Scully, Vin  
 1962 The earth the temple, and the gods. New Haven: Yale University Press.
- Shepard, Augustus  
 1931 Camps in the woods. New York: Architectural Publishing Company.
- Sloane, Eric  
 1954 American barns and covered bridges. New York: Funk and Wagnalls.  
 1964 A museum of early American tools. New York: Funk and Wagnalls.  
 1965 A reverence for wood. New York: Wilfred Funk, Inc.  
 1967 An age of barns. New York: Funk and Wagnalls.
- Sunset Magazine Staff  
 1975 Cabins and vacation homes. Menlo Park, Calif.: Lane Publishing Co.  
 1976 The log cabin renaissance; Sunset Magazine, October: 74-83.
- Waterman, Thomas T.  
 1950 The dwellings of colonial America. Chapel Hill, N.C.: University of North Carolina Press.
- Wiggington, Eliot; Editor  
 1972 The foxfire book. Garden City, N.Y.: Doubleday and Co.  
 1977 The foxfire book IV. Garden City, N.Y.: Doubleday and Co.,/Anchor Press.
- Williams, John S.  
 1843 Our cabin; or life in the woods. American Pioneer 2(10): 435-439.  
 An original account of cabin construction on the Ohio frontier.

Part 4 - Regional Studies

A. The Western United States

Attebery, Jennifer Eastman  
1976 Log construction in the Sawtooth Valley of Idaho. Pioneer America  
8(1): 36-46.

Beauvais, Robert  
1972 New Mexico log residence of Stephan W. Dorsey. New Mexico  
Architecture Magazine, Nov./Dec.

Carlson, Axel R.  
1977 Building a log house in Alaska. Fairbanks, Alaska: University of  
Alaska Cooperative Extension Service.

Carrey, Johnny, and Cort Conley  
1977 The Middle Fork and the Sheepeater War. Riggins, Idaho: Backeddy  
Books.

1978 River of no return. Riggins, Idaho: Backeddy Books.

1979 Snake River of Hells Canyon. Riggins, Idaho: Backeddy Books.

All three of these Carrey/Conley books are informal histories, based mostly on oral history of the areas discussed. Very good recent and older photos along with dates of construction for many of the shown structures give them some typological merit.

Comstock, William Phillips  
1915 Bungalows, camps, and mountain houses. William Comstock Co.

Fontana, Bernard L.  
1967 The archaeology of post-18th century ranches in the United States.  
Historical Archaeology 1:60-63.

While not concerned with structures in particular, Fontana looks at the relations between structures, activities, and means of subsistence.

Gritzner, Charles F.  
1969 Spanish log construction in New Mexico. Doctoral dissertation,  
Louisiana State University.

A very complete study of building techniques and types in New Mexico.

1971 Log housing in New Mexico. Pioneer America 3(2): 60-63.

Discusses Mexican influences in housing from the southwestern United States, emphasizing differences in form, function, and materials.

- Hartung, John A.  
1978 Documentation of primitive resources in the Idaho Primitive Area, Big Creek drainage. Unpublished thesis, University of Idaho, Forestry Department.  
  
A report documenting field inventories and oral history. Includes many photos of structures, both occupied and abandoned.
- Jackson, J. B.  
1975 A catalog of New Mexico building terms. Landscape 1(3): 31-32.  
  
A short glossary of Mexican architectural terms, both official and vernacular.
- McDaniel, Marion, and Jerry Wylie  
1979 Cultural resource evaluation of Sater Cabin - Little Creek. Middle Fork Ranger District, Challis National Forest, Idaho. USDA, Forest Service, Intermountain Region.
- Muckelroy, Duncan C.  
1974 Ranching history of the American West: revitalized through the preservation of its architecture. Pioneer America 6(2): 34-42.  
  
Looks at examples of preserved Texas ranch houses, including dugouts, and vertical log construction.
- Perry, Edgar  
1971 The old log cabin. Tucson: The Arizona State Historical Society.
- Pittman, Leon Sidney  
1973 A survey of the 19th century folk housing of the Mormons. Salt Lake City: Utah State Historical Society.
- Proenneke, Keith, and Richard Proenneke  
1973 One man's wilderness. Anchorage, Alaska: Alaska Northwest Publishing Company.
- Rice, Ed  
1975 Building in the North. Fairbanks, Alaska: Geophysical Institute, University of Alaska.
- Schumann, David R.  
1976 Building with house logs in Alaska. Juneau, Alaska: Division of State and Private Forestry, USDA, Forest Service.
- Segger, Martin  
1977 Log idom survivals in West Coast architecture (1890-1930). Banff, Alberta: Canadian Log Structures Conference.



- Sultz, Phillip W.  
1964 From sagebrush to hay and back again. American West 1(1): 20-30.  
A photo-essay of log structures around Jackson Hole, Wyoming.
- 1969 Architectural values of early frontier log structures. From Forms upon the frontier: folklife and folk arts in the United States. Logan, Utah.  
Again dealing with Jackson Hole, Wyoming, but also discusses the factors that may have influenced structural design.
- Sutherland, M., and J. Lock  
1949 Adobe New Mexico. National Geographic 96(6): December.
- Vaughan, Thomas; Editor  
1974 Space, style, and structure: buildings in northwest America (2 volumes). Portland: Oregon Historical Society.  
A thorough examination of Northwest building styles from pioneer days to modern cities.
- Woodward, Claire V.  
1975 Ethnohistory of Baker Cabin, Clackamas City, Oregon. Unpublished thesis, Portland: Portland State University.
- Wylie, Jerry  
1978 Cultural resource evaluation of the Sack (Kipp) cabin, Big Springs. Island Park Ranger District, Targhee National Forest, Idaho. USDA-Forest Service, Intermountain Region.
- 1979 A cultural resource evaluation of the Cabin Creek Ranch, Payette National Forest. Appendices by Rossillion and Sprague, Green, Attebery, Dalstrum, Hartung, and Wells. USDA-Forest Service, Intermountain Region.

B. The Midwest and Plains States

Bonebright, Harriet

1921 Reminiscences of Newcastle, Iowa in 1848. Des Moines: State of Iowa History Dept.

Brandt, Lawrence R., and Ned E. Braatz

1972 Log buildings in Portage County, Wisconsin: some cultural implications. Pioneer America 4(1): 29-39.

Dale, Edward E.

1945 From log cabin to sod house. Journal of the Illinois State Historical Society 38(4): December.

Fisher, Oneita

1965 Life in a log cabin. Annals of Iowa 37(8): 561-573.

Hudson, John

1975 Frontier housing in North Dakota. State Historical Society of North Dakota: Fall.

Hutslar, Donald A., and Jean J. Hutslar

1971 The log architecture of Ohio. Ohio History 80(3 and 4).

A major work documenting a 6-year study.

Irish, Jane

1940 Log cabins of Iowa. Iowa State Historical Society: WPA File #2.

Karni, Michael, and Robert Levin

1972 Finnish log cabins in Minnesota. North West Architect May/June: 92-99.

Klammer, Paul A.

1960 Collecting log cabins: a photographer's hobby. Minnesota History 37(2).

Koch, William

1974 Corner timbering and wood use in Kansas log structures. Manhattan, Kan.: Kansas State University.

Marshall, Howard Wight

1971 The "thousand acres" log house, Monroe County, Indiana. Pioneer America 3(1): 48-56.

Meyer, Douglas K.

1975 Diffusion of folk houses in the Shawnee Hills of Illinois. Pioneer America: July.

Perrin, Richard W. E.

1967 The architecture of Wisconsin. Madison: The State Historical Society of Wisconsin.

- Petersen, William J.  
 1960 A pioneer log cabin. Palimpsest State Historical Society 41(11):  
 November.
- Roberts, Warren E.  
 1977 The tools used in building log houses in Indiana. Pioneer America  
 9(1): 32-61.
- Schutte, John A. C.  
 1973 Record of log house restoration - New Salem, Illinois. Illinois  
State Historical Society.
- Stauffer, Florence S.  
 1978 Conner Prairie pioneer settlement: a living museum. Early American  
Life 9(1): 38-41, 54.
- Vlach, John W.  
 1972 The Canada homestead: a saddlebag log house in Monroe County,  
 Indiana. Pioneer America 4(2): 8-17.
- 1895 The old log house. Michigan Pioneer and Historical Society.
- Welsch, Roger L.  
 1980 Nebraska log construction: momentum in tradition. Nebraska History,  
 fall: 310-335.
- Witzel, S. A.  
 1935 Log buildings. Madison: Agricultural Extension Service Circular 158,  
 University of Wisconsin.

C. The East and the South

- Alexander, Drury B., and Tod Webb  
1966 Texas homes of the nineteenth century. Austin: The University of Texas Press.
- Alcott, John V.  
1963 Colonial homes in North Carolina. Carolina Charter Tercentenary Committee, Raleigh.
- Arthur, E. R., and D. Whitney  
1972 The barn. New York: New York Graphic Society.
- Baber, Adin, and Mary E. Lobb  
1969 The Lincoln log cabins. Lincoln Herald 71(1): 19-26.
- Bastian, Robert W.  
1977 Indiana folk architecture: a lower mid-western index. Pioneer America 9(2): 113-136.
- Black, Patti Carr  
1976 Mississippi piney woods architecture. Jackson: Mississippi State History Museum.
- Bucher, Robert C.  
1962 The continental log house. Pennsylvania Folklife 12(4): 14-19.
- Conger, Roger N.  
1954 Historic log cabins in McLennan County, Texas. Waco, Texas: Heritage Society of Waco.
- Connor, Seymor V.  
1949 Log cabins in Texas. The Southwestern Historical Quarterly 53(2): 105-115.
- Durham, Walt. T.  
1974 Wynnewood. Tennessee Historical Quarterly 33(2): 48-56.
- Dwyer, Charles P.  
1872 The immigrant builder - or practical hints for the handyman. Philadelphia: Claxton, Remsen, and Haffelfinger.
- Franklin, James  
1973 Castilian Springs preservation - Tennessee log complex. Chattanooga, Tenn.: James Franklin and Associates.
- Glassie, Henry  
1963 The Appalachian log cabin. Mountain Life and Work 39(4): 5-14.

- 1964 The smaller outbuildings of the southern mountains. Mountain Life and Work. 21-29.
- 1965a A central chimney continental log house. Pennsylvania Folklife 18(2): 33-39.
- 1965b The old barns of Appalachia. Mountain Life and Work, summer: 21-29.
- 1968a Pattern in the material folk culture of the eastern United States. Philadelphia: University of Philadelphia Press.
- 1968b The types of the southern mountain cabin. Appendix C of Jan Bruvand's The Study of American Folklore. New York: W. W. Norton.
- 1975 Folk housing in Middle Virginia. Knoxville: University of Tennessee Press.
- Giles, Henry E., Janice Holt Giles  
 1963 A little better than plumb: the bibliography of a house. Boston, Mass.: Houghton Mifflin.
- Heimsath, Clovis  
 1968 Pioneer Texas buildings - a geometry lesson. Austin, Texas: University of Texas Press.
- Hendershott, Allan  
 1937 Handicrafts in the southern highlands. New York: The Russell Sage Foundation.
- Hulan, Richard H.  
 1975 The middle Tennessee dogtrot house. Pioneer America 7(2): 37-46.
- Jeffers, Jack  
 1975 Cabins of the Blue Ridge: a photographic essay. Virginia Cavalcade 24(3): 116-123.
- Johnston, Francis B.  
 1941 The early architecture of North Carolina. Chapel Hill: University of North Carolina Press.
- Jordan, Terry G.  
 1978 Texas log buildings: a folk architecture. Austin, Texas: University of Texas Press.
- 1976 Log timbering in Texas. Pioneer America 8(1): 8-18.
- Pillsbury, R., and A. Kardos  
 1970 A field guide to folk architecture of the northeastern United States. Hanover, N.H.: Dartmouth College Press.

- Kelley, J. Frederick  
 1924 Early domestic architecture of Connecticut. New Haven, Conn.: Yale University Press.
- 1940 A seventeenth century Connecticut log house. Old Time New England Society for the Preservation of Antiques: October.
- Kniffen, Fred B.  
 1936 Louisiana house types. Annals of the Association of American Geographers 26: 179-193.
- 1966 Building with wood in the eastern United States: a time-place perspective. (coauthored with Henry Glassie) Geographical Review 56(1): 40-66.
- 1963 The physiognomy of rural Louisiana. Louisiana History 4(4): 291-299.
- McMurty, R. Gerald  
 1974 The Hardin Thomas House (Kentucky). Lincoln Herald 76(1): 172-271.
- McRaven, Charles  
 1978 Building the hewn log house. Hollister, Mo.: Mountain Publishing Services.
- Montell, W. L.  
 1976 Kentucky folk architecture. Lexington, Ky.: Kentucky Bicentennial Bookshelf, University Press.
- O'Malley, James R., and John Brender  
 1978 The two-story log cabin in the Upland South. Popular Culture 11(4): 904-915.
- Rosenberger, Jesse Leonard  
 1923 The Pennsylvania Germans. Chicago: University of Chicago Press.
- Stuck, Goodloe  
 1971 Log houses in northwest Louisiana. Louisiana Studies 10(4): 225-237.
- 1978 Restoring a log house in De Soto Parish. North Louisiana Historical Association 9(3): 143-146.
- Thomas, James C.  
 1974 The log houses of Kentucky. Antiques 105: 791-798.
- Wacker, Peter O., and Bob Trindel  
 1969 The log house in New Jersey - origins and diffusion. Keystone Folklore Quarterly: Winter.
- Wells, Carol  
 1975 Earliest log cabins of the Natchochites. North Louisiana Historical Association Journal 6(3): 117-122.

- Weslager, C. A.  
1955 Log houses in Pennsylvania during the seventeenth century.  
Pennsylvania History 5(22): 256-265.
- Willis, Stanley  
1972 Log houses in southwest Virginia: tools used in their construction.  
Virginia Cavalcade 21(4): 36-47.
- Wilson, Eugene  
1975 Alabama folk houses. Montgomery, Ala.: Alabama Historical Commission.
- Woods, John  
1904 Two years residence in settlements on the English prairie. Early Western Travels, 1748-1846, edited by Rueben G. Thwaites: 274-279.  
Cleveland.
- Zelinsky, Wilbur  
1953 The log house in Georgia. Geographical Review 43(2): 173-193.

D. - Outside the United States

- Abler, Thomas S.  
1970 Longhouse and palisade, northwest Iroquoian village of the seven-teenth century. Ontario History 62: 17-40.
- Alnaes, Eyvind, et al.  
1950 Norwegian architecture throughout the ages. Oslo, Norway: H. Aschehough and Co.
- Arthur, Eric Ross  
1938 The early buildings of Ontario. Toronto, Ontario: University of Toronto Press.
- Boethius, Gerda  
1927 Studier i den Nordiska timmerbyggnadskonsten. Stockholm, Sweden.  
1977 The Canadian log house. Prince George, B.C.
- Bugge, Gunnar, and Christian Norborg-Schulze  
1969 Early wooden architecture in Norway. Oslo, Norway: Byggekunst.
- Burcaw, George E.  
1973 The Saxon House as a cultural index in European ethnography. Moscow, Idaho: University of Idaho Press.
- Clemson, Donovan  
1974 Living with logs: British Columbia's log buildings and rail fences. Sanichton, B.C.: Hancock House.
- Erexon, Sirgud  
1937 The north European technique of corner-timbering. Folkliv 1:56-68.
- Gimbutas, Margia  
1956 The prehistory of Eastern Europe. Cambridge, Mass.: The Peabody Museum.  
1963 The Balts. London, England: Thames and Hudson.
- Gowans, Alan  
1958 Looking at architecture in Canada. Toronto, Ontario: Oxford University Press.
- Gullet, Edwin C.  
1963 The pioneer farmer and backwoods man. Toronto, Ontario: University of Toronto Press.
- Hale, Richard W.  
1963 The French side of the log cabin myth. Mass. Historical Society: 118-125.



- Hansen, Hans Jurgen  
1971 Architecture in wood. London, England: Faber and Faber.
- Hallerot, Bjorn  
1965 Timmerhus. Falv Nya Boktryckeri, Artifbolag.
- Jacquet, Pierre  
1963 The Swiss chalet. Zurich: Orell Fussli.
- Kavli, Guthorm, et al.  
1958 Norwegian architecture - past and present. Oslo, Norway: Dreyers Forlag.
- Lafromboise, Yves  
1975 L'architecture traditionnelle au Quebec aux 17 at 18 siecles. Montreal, Quebec: Les Editions De L'Homme.
- Lehr, John  
1976 Ukranian vernacular architecture in Alberta. Alberta Cultural History Resources Commission (1).
- Mackie, B. Allan  
1972 Building with logs. Prince George: Hairy Woodpecker Publications.  
1974- The Canadian log house (annual publication). Prince George: Allan  
1978 Mackie Publications.
- Mercer, Eric  
1975 English vernacular architecture. London, England: Royal Commission on Historical Documents.
- Patterson, G., and L. G. Patterson  
1938 Pioneer days in Ontario. Toronto, Ontario: Ryerson Press.
- Rempel, John I.  
1967 Building with wood and other aspects of nineteenth century building in Ontario. Toronto, Ontario: University of Toronto Press.
- Richardson, A. H. J.  
1973 A comparative study of timber buildings in Canada. Ottawa, Ontario: Association for Preservation Technology.
- Ritchie, T.  
1967 Canada buildings - 1867-1967. Toronto, Ontario: University of Toronto Press.  
1971 Plank wall framing: a modern wall construction with an ancient history. Paper #347, Division of Building Research, Ottawa, Ontario.
- Roberts, Warren  
1976 Some comments on log construction in Scandinavia and the United States. Bloomington, Ind.: Indiana Folklore Institute, Indiana University.

Roe, Frank Gilbert

1958 The old log house in western Canada. Alberta Historical Review  
6(2): 1-9.

Vriem, Halvor

1937 The ancient settlements of Finmark, Norway. Folkliiv 2, 3.

Wade, Jill

1971 Log construction at the Red River. Canadian Antiques Collector:  
30-36, November/December.

Weslager, C. A.

1952 Log structures in New Sweden during the seventeenth century.  
Delaware History 5: 77-95.

Winberry, John J.

1974 The log house in Mexico. Annals of the Association of American  
Geographers 64:54-69.

Wonders, William C.

1979 Log dwellings in Canada. Annals of the Association of American  
Geographers 69(2): 187-207.

Part 5 - Construction and Restoration

Anderson, L. O.

- 1975 Wood house construction. Agricultural Handbook 73. Washington: Government Printing Office.

Angier, Bradford

- 1952 How to build your home in the woods. New York: Sheridan House, Hart Publishing.

Balkan, Donna

- 1976 How to build a log house of 240 pine logs. Ontario Citizen: October 30.

Barton, Arthur

- 1941 Log cabin construction. Bulletin 22, Michigan State Extension Service.

Brimmer, Frank E.

- 1925 Camps, log cabins, lodges, and clubhouses. New York: D. Appleton and Company.

Bruette, William Arthur; Editor

- 1934 Log cabins and cottages; how to build and furnish them, by practical architects and woodsmen. New York: A. Bruette.

Includes a section (pp. 8-39) originally published in 1889 under the title of "Log Cabins," by William S. Wicks.

Coon, Milton C.; Editor

- 1964 Restoration and preservation of historic buildings. Building Research 1(5).

Provides benchmark data for the documentation of historic structures.

DeGroot, Rodney C.

- 1976 Your wood can last for centuries. USDA. Washington: Government Printing Office.

Dillion, Ralph P.; Editor

- 1938 Sunset's cabin book. San Francisco: Sunset Magazine.

Fikes, C. P.; Editor

- 1935 Construction and maintenance of Forest improvements. Region 1 Handbook, U.S. Forest Service.

An excellent source of techniques, plans, and construction concepts utilized by the Forest Service throughout the Rocky Mountain west.

- 1957 Building with logs. U.S. Forest Service misc. publication 579.

- Goodall, Harrison, and Renee Friedman  
 1980 Log structures: preservation and problem-solving. Nashville, Tenn.:  
 Society for State and Local History.
- Hard, Roger  
 1977 Build your own low-cost log house. Charlotte, Vt.: Garden Way  
 Associates.
- Hunt, Walter B.  
 1939 Rustic construction. Milwaukee, Wis.: Bruce Publishing Company.  
 1939 How to build and furnish a log cabin. New York: Collier - Macmillan  
 Company (revised editions also 1947, 1974).
- Hutslar, Donald A.  
 1974 Log cabin restoration; guidelines for the historical society. History  
 News (History Technical Leaflet 74).
- Jenkins, Thomas A.  
 1976 Relocation and restoration of a North Carolina log home. Chapel Hill,  
 N.C.: North Carolina Bicentennial Commission.
- Leitch, William C.  
 1976 Hand-hewn: the art of building your own cabin. San Francisco:  
 Chronicle Books.
- Livingstone, Jeffery  
 1955 Build your own summer camp or cabin. New York: McGraw-Hill Company.
- Mason, Bernard S., and Frederick H. Kock  
 1947 Cabins, cottages and summer homes. New York: A. S. Barnes and  
 Company.
- Meinecke, Conrad E.  
 1947 Cabincrafts and outdoor living. Buffalo, N.Y.: Foster and Stewart.  
 1945 Your cabin in the woods, a compilation of cabin plans and philosophy  
 for discovering life in the great out-doors. Buffalo, N.Y.: Foster  
 and Stewart Publishers.
- Henderson, Tracey  
 1977 Log cabin kits - you can build them yourself. Western Living Magazine,  
 May.
- Munger, John W.  
 1949 How to build a log cabin. Detroit, Mich.: Griffen H. Munger
- Parker, J. B.  
 1932 Vacation cabins: a selection of small cabins for comfort, utility,  
 and economy. Memphis, Tenn.: Cooke Printing Company.

- Phillips, R. A. G.  
1976 Moving and erection of log buildings. Heritage Canada: November.
- Roe, Frank Gilbert  
1958 The old log house in western Canada. Alberta Historical Review 6(2): 1-9.
- Roff, J. W., and R. S. Smith  
1975 Protection and preservation of wood in service. Vancouver: Western Forest Products Lab.
- Rowell, Black, Gjovik, and Feist  
1977 Protecting log cabins from decay. Madison, Wis.: USDA-Forest Service; Forest Products Laboratory General Technical Report PPL-11.
- Rustrum, Calvin  
1972 The wilderness cabin. New York: Macmillan Publishing Company.
- St. George, R. A.  
1962 Protecting log cabins from insects in the eastern United States. Washington, D.C.: Government Printing Office No. 2104.
- Scharff, Robert  
1952 Complete summer homes handbook. New York: Prentice-Hall.
- Schutte, John A. C.  
1973 Record of log house restoration - New Salem, Illinois Springfield, Ill.: Illinois State Historical Society.
- Walton, Harry  
1964 How to build your cabin or vacation home. New York: Popular Science Book; Harper and Roe Publishers.
- Warrick, John  
1949 How to build a log cabin. Detroit, Mich.: G. H. Munger.
- Wicks, William S.  
1889 Log cabins: how to build and furnish them. New York: Forest and Stream Publishing Company.
- Witzel, S. A.  
1935 Log buildings. Circular #158, Agricultural Extension Service. Madison, Wis.: University of Wisconsin.

## Part 6 - Bibliographies

Hill, Donald R.

- 1978 Select bibliography list of log homes and related wilderness experiences. Not published; Mr. Hill a consultant for Log Home Builders Guide: Muir Publishing Company, Rutland, Vt.

While not annotated, this is one of the largest bibliographies available. Emphasis is with cabin construction; over 100 entries. Most of these works are from popular and trade sources.

Look, David W.

- 1975 Selected bibliography on cottages and cabins. Washington: Office of Archaeology and Historic Preservation, National Park Service, U.S. Dept. of the Interior.

The emphasis on this bibliography is on construction; it includes many older listings; 31 references are sited; it is not annotated.

- 1975 Selected bibliography on log structures. Washington: Office of Archaeology and Historic Preservation, National Park Service, U.S. Dept. of the Interior.

Similar to Look's other bibliography, but more emphasis on typology and regional studies, including those outside the United States. Over 30 listings; it is not annotated.

Walker, Richard I.

- 1974 Log cabin construction (origin and history): annotated bibliography. Unpublished, at Anthropology Department, University of Idaho.

Includes 33 references covering construction, history, and regional studies; very useful annotations.

Wylie, Jerry, and Mary A. Wilson

- 1980 A selected log cabin annotated bibliography. Idaho Cultural Resource Handbook, Intermountain Region (4), Forest Service, USDA.

Includes 51 references; the most complete annotated bibliography available. Emphasis on regional studies, the western United States in particular.

## CULTURAL RESOURCE REPORTS

USDA Forest Service, Intermountain Region  
324 25th Street, Ogden, UT 84401

Jerry Wylie and Tom Scott  
Editors

- \*No. 1 - Archeological Reconnaissance Survey of the Bridger-Teton National Forest. George C. Frison (1975).
- \*No. 2 - The Elk Ridge Archeological Project: A Test of Random Sampling in Archeological Surveying. Evan I. DeBloois (1975).
- \*No. 3 - Lithic Sites of the LaSal Mountains, Southeastern Utah. Dee F. Green (1974).
- \*No. 4 - Pahsimeroi Valley Longitudinal Subsistence-Settlement and Land Use Study. James C. Chatters (1976).
- No. 5 - The Archeology of the Sheepeater Battleground and Redfish Overhang Sites: Settlement Model for Central Idaho. Joseph G. Gallagher (1979).
- No. 6 - An Overview of History in the Drainage Basin of the Middle Fork of the Salmon River. Mary P. Rossillon (1981).
- \*No. 7 - A Cultural Resource Reconnaissance of the Middle Fork Salmon River, Idaho, 1978. Ruthann Knudson and others (1982).
- No. 8 - A Cultural Resource Overview of the River of No Return Wilderness, Idaho. Leslie Wildesen (1982).
- No. 9 - Log Cabin Studies. Mary Wilson (1984).

\*(Out of print)

