

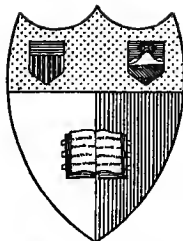

HG
1586
W52
v. 2



Cornell University Library
Ithaca, New York

BOUGHT WITH THE INCOME OF THE
SAGE ENDOWMENT FUND
THE GIFT OF
HENRY W. SAGE

1891

The date shows when this volume was taken.

To renew this book copy the call No. and give
to the librarian.

HOME USE RULES

MAR 21 1952 G

All Books subject to recall

All borrowers must register in the library to borrow books for home use.

All books must be returned at end of college year for inspection and repairs.

Limited books must be returned within the four week limit and not renewed.

Students must return all books before leaving town. Officers should arrange for the return of books wanted during their absence from town.

Volumes of periodicals and of pamphlets are held in the library as much as possible. For special purposes they are given out for a limited time.

Borrowers should not use their library privileges for the benefit of other persons.

Books of special value and gift books, when the giver wishes it, are not allowed to circulate.

Readers are asked to report all cases of books marked or mutilated.

Do not deface books by marks and writing.

CORNELL UNIVERSITY LIBRARY



3 1924 092 592 710

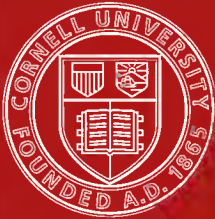

Cornell University Library

The original of this book is in
the Cornell University Library.

There are no known copyright restrictions in
the United States on the use of the text.

BANKING PRINCIPLES AND PRACTICE

By

RAY B. WESTERFIELD, PH.D.

Assistant Professor of Political Economy, Yale University;
Secretary-Treasurer, American Economic Association

IN FIVE VOLUMES

VOLUME II

THE BANKING SYSTEM OF THE
UNITED STATES



NEW YORK

THE RONALD PRESS COMPANY

1921

~~to 511.~~

~~4. 11. 11.~~

A508652

Copyright, 1921, by
THE RONALD PRESS COMPANY

All Rights Reserved

LIBRARY
UNIVERSITY
CORNELL

HZ

CONTENTS

VOLUME II—THE BANKING SYSTEM OF THE UNITED STATES

CHAPTER	PAGE
XII ANTECEDENTS OF THE FEDERAL RESERVE SYSTEM . . .	211
Classification of the Financial Institutions	
The First Bank of the United States	
Services of First Bank to Government	
Dissolution of First Bank	
The Second Bank of the United States	
History of Second Bank	
Weaknesses in Operation of Second Bank	
Defects of Note Redemption System	
Services of Second Bank to Commerce	
Causes of Dissolution of Second Bank	
State Banks Before the Civil War	
Causes of Panic of 1837	
The Independent Treasury System	
Bases of Note Issue Before the Civil War	
Evils of Early Bank Note Issues	
Proposed Advantages of National Bank Note Issue	
The National Banking Act	
The Growth of the National Banking System	
Movement to Reform National Banking System	
XIII FEDERAL RESERVE DISTRICTS AND MEMBERSHIP . . .	238
The Federal Reserve Districts	
Boundaries of Federal Reserve Districts	
Domestic Branches of Federal Reserve Banks	
Foreign Branches of Federal Reserve Banks	
Membership in Federal Reserve System	
Legal Requirements of Membership	
Procedure in Applying for Membership	
Growth in State Bank Membership	
Objections to Membership	
Reasons for Membership	
New Powers of National Banks	
XIV FEDERAL RESERVE BANKS	258
Capitalization of Federal Reserve Banks	
Surplus	
Earnings and Operating Costs	
The Board of Directors	
Election of Directors	
The Federal Reserve Agent	

CHAPTER	PAGE
Internal Organization	
Reorganization of Federal Reserve Bank of New York 1919	
The Governor	
Powers of the Reserve Banks	
Typical Bank Departments	
Resources and Liabilities of the Federal Reserve Banks	
Liabilities of the Federal Reserve Banks	
Fiscal Agents of the United States	
The Treasury and Reserve Banks	
Duties of Former Sub-Treasuries	
XV THE FEDERAL RESERVE BOARD	285
Membership of the Board	
Criticism of Constitution of the Board	
Powers and Responsibilities	
Administrative Duties	
The Federal Advisory Council	
The Comptroller of the Currency—Powers and Duties	
The Comptroller's Examiners	
National Bank Reports	
XVI DOMESTIC AND FOREIGN BRANCH BANKING	296
Branch Banking Within the United States	
State and National Branch Banks	
Development of Branch Banking	
Need for Foreign Branches of American Banks	
Foreign Branch Banks Established	
Ownership and Management of Foreign Branches	
Growth and Functions of Foreign Branches	
Federal Foreign Banking Associations	
Provisions of the Edge Act	
Powers of the Edge Corporations	
Edge Corporations Established	
XVII LEGISLATION GOVERNING NATIONAL BANK NOTE ISSUE	311
Bond Deposit Requirement from 1864 to 1900	
The Aldrich-Vreeland Act—Emergency Circulation of As- sociations	
Emergency Circulation of National Banks	
Character of the Emergency Notes	
Effect of War on Emergency Circulation	
Conversion and Refunding of Bonds under the Federal Reserve Act	
Effect of Liberty Bond Issues on Bond Refunding and Conversion	
Retirement of National Bank Notes	
The Pittman Act of 1918	
The Deposited Bonds	

CONTENTS

v

CHAPTER	PAGE
XVIII NATIONAL BANK NOTES	328
Preparation of National Bank Notes	
Denominations and Character	
The Redemption Fund	
Method of Note Redemption	
Withdrawal of Circulation	
Effect of Liquidation	
Effect of Failure to Redeem upon Demand	
The Tax on National Bank Notes	
Public Advantages of National Bank Notes	
Banking Advantages of National Bank Notes	
Method of Calculating Profit on Note Circulation	
Disadvantages of National Bank Notes	
Inelasticity	
Other Disadvantages	
XIX FEDERAL RESERVE NOTES	350
Issue of Federal Reserve Notes	
Methods of Redemption and Retirement	
Effect of Gold Reserve Concentration	
Amendment Providing for Direct Issue	
Reserves of Federal Reserve Banks	
Tax on Deficiency of Reserves	
Other Devices for Obviating Deficiencies of Reserves	
Movement of Reserve Ratio	
Characteristics of Federal Reserve Notes	
Provisions for Controlling Excessive Issues	
Responsibility for Stemming Inflation	
Safety of Federal Reserve Notes	
Elasticity of Federal Reserve Notes	
XX DISCOUNT OPERATIONS OF THE FEDERAL RESERVE BANKS	374
Paper Eligible for Rediscount	
1. Rediscounting for Member Banks	
Effect of War on Discount of Commercial Paper	
Statistical Statement of the Discounts	
2. Open-Market Operations	
3. Rediscount Operations Between Federal Reserve Banks	
Discount Rates of Federal Reserve Banks	
Factors Influencing Discount Policy of Federal Reserve Board	
Control by Lines of Credit	
XXI RESERVES AGAINST DEPOSITS UNDER NATIONAL BANKING ACT	387
Legal Requirements	
System of Redeposited Reserves	
Bank Correspondents	
Effect of System on Concentration of Money	
Competition for Deposit Balances	

CHAPTER	PAGE
Effect of Redeposited Reserves on Securities and Money Markets	
Effect on Cash Carried, Exchange, and Accommodation Reserves and Stock Exchange Loans	
Fictitious Reserves	
Evils of Legal Minimum Reserve	
Decentralization of Reserves	
XXII RESERVES AGAINST DEPOSITS UNDER THE FEDERAL RESERVE ACT	400
Legal Requirements	
Amendments to Reserve Requirements	
Amounts and Distribution of Reserves	
Effects of Federal Reserve System on Reserves	
1. Reduction of Reserves	
2. Concentration of Reserves	
3. Decentralization of Bank Balances in Central Reserve Cities	
4. Cessation of Interest Payments on Reserves	
Calculation of Reserves of Member Banks Against Deposits	
Definition of Reserve Cities	
Reserves of the Federal Reserve Banks Against Deposits	
Nature of the Gold Settlement Fund	
Operation of Gold Settlement Fund	
Functions and Transactions of Gold Settlement Fund	
Telegraphic Transfer of Funds	
Members' Drafts on Federal Reserve Banks	
The Par Collection System	
Progress of Par Collection System	
Statistical Statement of Deposits in the United States	
XXIII INSTITUTIONS OTHER THAN NATIONAL AND FEDERAL RESERVE BANKS	426
Composition of the Banking System of the United States	
State Banks—Growth	
Requirements as to Capital	
Limitations as to Loans	
Requirements as to Reserves, Branches, and Supervision	
Trust Companies—Legal Requirements	
Growth of Trust Companies	
Causes of Recent Growth	
Supervision and Regulation	
Private Bankers	
Mutual and Joint-Stock Savings Banks	
Statistical Statement of the Banking System of the United States	
XXIV INSTITUTIONS OTHER THAN NATIONAL AND FEDERAL RESERVE BANKS (Continued)	443
Postal Savings Banks	
School Savings Banks	

CONTENTS

vii

CHAPTER	PAGE
<ul style="list-style-type: none"> Building and Loan Associations—Nature and Organization Operations and Functions Statistical Summary Savings in the United States The Loan Shark Remedial Loan Systems Morris Plan Banks Advantages of Morris Loan Plan Cattle Loan Companies Nature and Terms of Cattle Loans Rediscounting Cattle Paper Security and Liquidity of Cattle Paper The Federal Farm Loan System Federal Land Banks Federal Farm Loan Bonds National Farm Loan Associations Joint-Stock Land Banks Federal Farm Loan Board 	469
XXV	BANK ORGANIZATION AND CONVERSION
<ul style="list-style-type: none"> Introductory Organization of a New National Bank Requirements for Formal Application Examination of Application Articles of Association and Organization Certificate Election of Directors and Officers Requirements as to Capital Stock Subscriptions Requirements as to Circulation Reorganization of a Bank into a National Bank Conversion of a State Bank into a National Bank Organization of a State Bank—Preliminary Requirements Authorization Certificate Qualifications of Directors Organization of a Trust Company Conversion of a State Bank into a Trust Company Conversion of a Trust Company Organization of a Mutual Savings Bank 	486
XXVI	CHARTER CHANGES, CONSOLIDATION, AND LIQUIDATION
<ul style="list-style-type: none"> Increasing Capitalization of a National Bank Reducing Capitalization of a National Bank Extension of Charter Change of Name or Location Requirements in Amending Charter Reasons for Consolidation of Banks The Agreement of Consolidation Approval of Consolidation Methods of Consolidation Liquidation of National Banks Conversion of a National Bank into a State Bank 	486

FORMS AND ILLUSTRATIONS

FIGURE	PAGE
4. The Federal Reserve Districts	242
5. Proposed Type of Organization for the Federal Reserve Banks, 1918	266
6. Official Organization of the Federal Reserve Banks of New York . . .	268
7. Graphic Chart Showing Reserves of the Twelve Federal Reserve Banks	363
8. Graphic Chart Showing Seasonal Variations in Federal Reserve Note Circulation	372
9. Graphic Chart Showing Earning Assets of the Federal Reserve Banks, 1914-1920	376

BANKING PRINCIPLES AND PRACTICE

VOLUME II

THE BANKING SYSTEM OF THE UNITED
STATES

CHAPTER XII

ANTECEDENTS OF THE FEDERAL RESERVE SYSTEM

Classification of the Financial Institutions

The banking system of the United States is dual in the sense that some institutions are authorized by federal statute and charters and other institutions by state statute and charters, and the two classes have developed in competition with each other.

The financial institutions to which federal charters are granted or which operate under federal law include:

1. Federal reserve banks.
2. National banks, some of which have local or foreign branches.
3. Federal land banks.
4. Federal joint-stock land banks.
5. National farm loan associations.
6. Postal savings depositories, including branch post-offices and stations.
7. "Edge" corporations.
8. The War Finance Corporation.

The state institutions are more varied in their nature, purpose, and operations. They embrace:

1. Commercial chartered banks.
2. Private individual banks.
3. Trust companies.
4. Mutual or trustee savings banks.
5. Joint-stock and "special deposits" savings banks.
6. Bond houses and investment companies.
7. Co-operative savings associations and building and loan associations.

8. Morris-plan banks.
9. Personal loan companies.
10. Personal loan brokers.
11. Land banks.
12. Mortgage loan companies.
13. Credit unions.
14. Discount houses.
15. Acceptance houses.
16. Note brokerage houses.
17. Finance companies.
18. Cattle loan companies.

The emphasis of this book is on commercial banking and the development of the federal reserve system. It is the purpose of this chapter to present the historical background of this system. Non-commercial banks are treated less fully, the discussion of such institutions being limited to Chapters XXIII and XXIV.

The First Bank of the United States

As part of a general scheme to support public credit in 1791, Alexander Hamilton prevailed upon Congress to institute the first Bank of the United States. His main arguments in support of the institution were:

1. The demonstrated success and usefulness of national banks in the chief European countries.
2. The more effective utilization of capital by concentrating the savings of the community for business uses.
3. The possible services of such a bank to the government in advancing loans and facilitating the payment of taxes.
4. The desirability of a bank note currency.

The opposition to the scheme was led by Madison and came from the southern states.

The law provided for a Bank of the United States, located at Philadelphia, capitalized at \$10,000,000, with shares at \$400 each,

subscriptions payable one-fourth in specie and three-fourths in United States securities bearing 6 per cent interest and payable within two years. The United States government subscribed \$2,000,000, which sum was loaned by the bank to the government, the loan to be repaid in ten annual instalments. Thus the payment of the government subscription was effected by what were virtually stock notes—a very faulty banking operation. The subscriptions in government securities were thought to give the bank a wider basis for note issue than would otherwise have been possible, as it would have been difficult to assemble \$10,000,000 in gold.

The bank was privately controlled by a board of directors of 25 members, one-fourth of whom at the end of each year became ineligible for re-election. Stockholders in foreign countries could not vote by proxy. The votes allowed per share decreased with the increase in the number of shares held by any one stockholder, thus providing for decentralized control, and no subscription, save that of the government, was to exceed 1,000 shares.

The bank was authorized to issue notes which were a legal tender in payment of all debts to the United States. The bank's debts were limited to the amount of the capital. This limitation could be exceeded only by authorization of Congress, and the directors were personally liable for the excess. The bank was forbidden to trade in merchandise, it was permitted to sell—but not to buy—United States securities, and its real estate investments were limited to its bank buildings and site. The bank was to make no loan to the United States in excess of \$100,000, nor to any state in excess of \$50,000, nor to any foreign country without the authorization of Congress. The maximum rate for loans and discounts was fixed at 6 per cent. The directors were empowered to establish branches within the United States. The bank was required to report its condition to the Secretary of the Treasury at his demand, but not oftener than once a week. The Secretary of the Treasury had the right to inspect the books

of the bank. The charter ran for twenty years and meanwhile the government was to establish no other bank.

In 1792 the bank established in the chief cities of the country eight branches, among which the \$10,000,000 capital was apportioned.

Bank notes were issued by the parent bank and its branches in denominations of \$5 and more, the total amount in circulation at any one time never exceeding \$6,000,000. As the parent bank refused to redeem the notes of its branches, this forced each branch to be self-reliant and tended to prevent overextension; this policy also relieved the parent bank from a sudden demand for large payment at any one of its branches. The bank used "half-notes" and "post-notes" to make payments at a distance. As these notes circulated widely, they had a salutary effect in restraining the overissue of notes by state banks.

Services of First Bank to Government

The government enjoyed many advantages from the bank, such as the \$2,000,000 loan for its stock subscription, which bore only 6 per cent interest, whereas the dividend rate on the stock was 8 per cent, the 2 per cent difference representing a net profit to the government. The Treasury also borrowed on short-term notes from the bank. When by 1795 long-term loans to the government amounted to \$6,200,000, or nearly two-thirds of its entire capital, this concentration of loans crippled its services to commerce and industry and also made it difficult for the institution to help the government with short-term accommodation. To liquidate its debt to the bank the government, between 1797 and 1802, sold its shares of the bank's stock—at premiums aggregating \$671,860. Meanwhile the government had received dividends amounting to \$1,101,720.

The relations between the Treasury and the bank were intimate. The bank granted loans to the Treasury, helped it to perform its foreign exchange business—for the bank did most of

the foreign and domestic exchange business of the country—acted as government depository, paying no interest on the public deposits, and in compensation for the use of the deposits transmitted public moneys from place to place free of charge. In addition the bank was of service to importers in the payment of custom duties, which were commonly paid in post-notes. After 1800 the Collector of the Internal Revenue used the bank as well as its branches to collect the maturing revenue bonds, promoting thereby greater punctuality and economy in the service.

Dissolution of First Bank

Because the bank was regarded as a Federalist institution, Jefferson and the Democrats were opposed to it, yet the institution was managed capably and with a view to profits and kept aloof from political controversies. Gallatin, who pleaded the bank's cause with Jefferson, was willing to waive political objections in consideration of the fiscal and business advantages of its operation, and in 1808 when the original charter was soon to expire he advocated its renewal. The objection which weighed most heavily against the bank was the large holdings of the bank's stock abroad and the consequent payment of dividends to foreigners. The trade organizations of the country in general favored the renewal of the charter but state jealousy of the national institution and the repressive effect of the bank and its branches on the smaller new state banks, served to fan political opposition. As a result Congress refused to renew the charter, and in 1811 the bank closed. Its officials attempted to procure a state charter for it in Pennsylvania, but failed. They obtained one, however, in New York under the name, Bank of America, and the concern continued to do business as a state institution.

The first Bank of the United States failed of success because of political opposition, despite the fact that it had served well both the government and the financial and commercial world.

The Second Bank of the United States

After the dissolution of the first Bank of the United States and during the war against Great Britain, the money market became badly disorganized, specie payments were suspended except in New England, and the public credit sank to a low ebb. A demand for the re-establishment of the bank arose spontaneously, the main reason being to restore to the country an orderly currency through the resumption of specie payments. Accordingly a bill was passed in 1816 creating a new bank, with a charter to run for twenty years.

The new bank was capitalized at \$35,000,000, in \$100 shares, one-fifth to be subscribed by the government and four-fifths by private subscribers. No one subscription was to exceed \$390,000. Subscriptions were payable within a year, one-fourth in specie, and the remainder in either specie or government bonds. The board of directors consisted of 25 members, 5 of whom were appointed annually by the President of the United States from several states, and the other 20 by the stockholders under a system of restricted voting. Not all the directors were eligible for re-election and no director could be a director of any other bank.

The bank was authorized to deal in bills of exchange and bullion and to sell goods pledged for loans, but was not to deal in any public stock. Loans to the United States were limited to \$500,000, and to any state to \$50,000. Debts, excluding deposits, were not to exceed the capital. The smallest denomination of bank note issued was \$5. All bank notes below \$100 denomination were payable upon demand, and were legal tender in payments to the government. The larger notes could run for terms up to 60 days. The organization of branches of the bank was required under certain conditions, and control of the branch was lodged with the parent institution by the appointment of the branch directors.

The bank was required to transmit public moneys at par and free of charge. The Treasurer was directed to deposit the govern-

ment funds in the bank or its branches; and if for any reason he did not do so, he was to report the reasons to Congress. In case of the suspension of specie payments, the obligations of the bank were subject to 12 per cent interest until resumption of such payments. The bank was to make periodical statements, not more often than once a week, to the Secretary of the Treasury, and he was empowered to inspect its books. A bonus of \$1,500,000 was levied upon the bank for its franchise.

History of Second Bank

Professor Dewey summarizes the history of the bank somewhat as follows. The bank was chartered on April 10, 1816, and on April 30 Congress ordered the resumption of specie payments to go into effect on February 20, 1817. The bank was quickly organized under the presidency of one Jones, and began operations in January, 1817. Owing to mismanagement, Jones was forced to resign in 1818, and Langdon Cheves became president. He held office until 1823, when he was succeeded by Nicholas Biddle. In June, 1829, Senator Woodbury of New Hampshire brought complaints against Jeremiah Mason, manager of the Portsmouth branch; in the following December President Jackson in his annual message questioned the constitutionality of the bank and accused it of failing to establish a sound currency. On April 30, 1830, a committee of the House of Representatives reported at length on the questions raised by Jackson, its conclusions being entirely favorable to the bank. A Senate report was likewise friendly. In 1831 Senator Benton supported a resolution against rechartering the bank. In January, 1832, the bank petitioned for recharter. This petition was favorably acted upon by committees of the Senate and the House and a bill for recharter was passed. The bill, however, was vetoed by Jackson, July 10, 1832. In the autumn of the same year Jackson was re-elected President, and he interpreted the vote as an indorsement of his opposition to the bank. In December, 1832, he raised the question as to whether

the funds of the government were safe in the custody of the bank. An investigation was ordered by the House, and a majority report of the Committee on Ways and Means upheld the policy of the bank and was adopted March 2, 1833, by a vote of 109 to 46. Notwithstanding this recommendation the President determined to remove the deposits, and in order to accomplish his purpose, on September 23 he dismissed Duane, Secretary of the Treasury, who objected to the removal, and appointed Taney in his place. The latter, on September 26, ordered that deposits henceforth be made in certain state banks, and on December 3, 1833, he reported to the Senate his reasons for their removal. In 1836 the charter of the bank expired.

Weaknesses in Operation of Second Bank

A number of weaknesses developed in the operations of the second bank during its earlier years. The subscription to its stock by means of stock notes was a mistake in that the method of payment amounted to a margin purchase of the stock and was therefore speculative in character; besides, the payments on the notes were very dilatory and renewals were freely made.

Friction also developed with the state banks over the transfer of public deposits and over the credit to be given to state bank notes. The state banks, with the exception of those in New York, Philadelphia, and Baltimore, refused to help the national bank effect the resumption of specie payments, and when this resumption was accomplished without their help they became embittered. When the national bank charged the delinquent banks interest on overdue balances, they regarded this as "an unprecedented grievance." The withdrawal of government deposits from a state bank usually led to a collision, not with the Treasury but with the national bank with which the funds were placed.

A controversy which centered in the West, where inflation had been carried further than elsewhere, arose over the acceptance of

state bank notes tendered in payment of public revenues. The Treasury and the bank instead of co-operating in the matter worked at cross-purposes. The Treasury permitted the collectors of internal revenue to receive state bank notes, the collection of which was thrown upon the national bank. This responsibility brought the latter into collision with the state banks, which were unable or unwilling to redeem promptly. The national bank held that whatever loss was incurred in the collection of the notes should devolve upon the Treasury, but the Treasury threatened to remove all public deposits rather than deprive the people of the means of paying for public lands and for their taxes. Naturally this dispute also contributed to the unpopularity of the national bank.

Political expediency as well as the terms of the charter demanded that many branches be established, and 27 in all were founded. Almost every state had at least one, and this was too many for the best business efficiency. Losses were greater in the branches than in the parent bank, for the reason that they were run more loosely and their management tended to yield to local pressure for favors in operation and policy. The branches were established with an eye to equalizing banking facilities over the country and consequently excessive amounts of cash were transferred to the South and West. Despite the number of branches, however, it was impracticable to open one in every collection district, and this was a further cause of complaint.

The volume of deposits fluctuated widely from month to month and this fluctuation was a very disturbing factor in the bank's loan operations. The original theory was that the bank and its branches were a unit and, since the bank was required to transmit government funds free of charge, the Treasury drew upon the bank at any place where public money was deposited, whether public funds happened to be there at that time or not, it being understood that the Treasury would give the bank reasonable notice of withdrawal so that provision might be made for

meeting the draft. Trouble soon arose between the bank and the Treasury because of lack of sufficient notice, but later a schedule of lengths of notice was arranged. The transfer of public moneys by the bank was a convenient arrangement for the government, and better than any that could have been provided by the state banks.

Defects of Note Redemption System

Though the original system of bank note redemption aided in effecting resumption by forcing the state banks to improve the standing of their notes and created a good national currency accepted everywhere, it was nevertheless defective. The parent bank agreed to redeem its own notes and those of the branches north of Charleston, without distinction, at any branch. One result was that the parent bank did not know where or when notes were likely to be presented. Loans were also created freely by certain branches, for the loaning branch knew that its notes would be presented elsewhere for redemption. In consequence, sudden and great demands were made, varying with the balance of trade, and it became useless for any one branch to be conservative.

For these reasons the system broke down in 1818, and the bank resolved that no branch should take the notes of other branches except in payments due to the United States. It further resolved that no branch should reissue notes of the parent bank or other branches except when it was a creditor of the other bank, and then only when the exchanges indicated that such reissue was for the interest of the parent bank. By making notes of \$5 denomination issued by any branch or by the parent bank acceptable at the others, however, a good currency was provided. But the burden of signing these notes of small denomination was so great that the bank officers sought relief from Congress; failing to secure this relief the bank in 1827 invented "branch drafts," in \$5 and \$10 denominations. These drafts were signed by the branch president and cashier, and drawn upon the parent bank;

they resembled bank notes in form, were indorsed payable to bearer, and circulated freely, supplanting the notes in certain areas. Their issue, however, was a leading cause of complaint against the parent bank, because such drafts were held to be contrary to the provisions of the bank's charter and harmful because they contracted the circulation of the state banks.

Services of Second Bank to Commerce

The second Bank of the United States operated in domestic exchange, the sale of drafts to the public constituting no small part of its business. The public and the Treasury argued that the bank ought to sell these drafts at par; but the bank charged varying rates of exchange, averaging $\frac{1}{2}$ per cent. These varying rates gave rise to the complaint that the bank showed favoritism and that it charged excessive and usurious rates. After 1820, however, the bank bought bills heavily and increasingly, and this helped to facilitate commerce and to equalize exchange. In this business it competed with the state banks. The exchange operations gave the bank a considerable control over the local currency by purchasing, or refusing to purchase, bills from the different areas.

During the first few years of the second bank's existence its services to commerce were restricted through the tying up of an undue proportion of its capital in stock notes received for subscriptions. With the change of management, however, its service improved and commercial loans of short-term usance were readily granted, mostly on pledge of personalty. Not only by aiding commerce in this and other ways, but also by its influence upon the state institutions, the bank proved its value to the community as a national institution.

Causes of Dissolution of Second Bank

The opposition which brought the bank to an untimely end was largely inspired by political intrigue and by selfish jealousy

on the part of the state banks. The charges of Jackson and other critics were that some of its officers who were incompetent were retained in office by political influence, that it tried to influence political elections and state legislation, and that some of the branches were established for political effect. It was further alleged that the bank was monopolistic and undemocratic in character and therefore dangerous to our institutions. On other grounds it was argued that the bank was unconstitutional. Some of its banking operations were held to be objectionable and violations of its charter, such, for instance, as the use of branch drafts, the practice of usury in exchange dealings, the sale of coin, trading in public securities, speculation in real estate, and the like. The aggressive and peculiar character of the Democratic President, with his large political following from the West and South, really explains why the inconsequential charges brought against so serviceable and successful an institution led to its dissolution.

State Banks Before the Civil War

Banking in the United States really dates from 1781, when Robert Morris, Superintendent of Finance of the Revolution, founded the Bank of North America at Philadelphia to promote the financing of Washington's army. The institution was chartered by the Continental Congress and was organized as a means of creating credits based upon the small amount of specie that existed and of making advances to the government. It was a complete success as a war measure and had a benign commercial influence as well. In 1782 it was chartered as a state bank in Pennsylvania, and under this charter, renewed from time to time, it enjoyed a very successful career until 1864, when it became a national bank, and is still a leading bank of Philadelphia.

In 1784 Massachusetts chartered the Bank of Massachusetts, and in New York, under Hamilton's influence, the Bank of New

York was founded and put into operation but the state refused to grant it a charter until 1791. The tendency in both these states, as time passed, was to lay heavier restrictions upon their banks. The restrictions included the imposition of personal liability upon directors for any violation of the law that debts should not exceed some specified multiple of the paid-in capital, the limitation of notes to large denominations, the prohibition of dealing in merchandise or stocks, and the requirement of reports of condition.

By the year 1800 the number of state banks had increased to 28, and by 1811, to 88. This rapid increase, though it indicated the need of credit institutions, was also a leading cause of the opposition to the rechartering of the first Bank of the United States. In the period from 1812 to 1816 the Treasury of the United States employed the state banks as depositories of the public funds. The poor conduct of the national finances, particularly the failure to levy taxes, the heavy issue of Treasury circulating notes, and the drain of specie abroad precipitated suspension of specie payments by all state banks, except those in New England, and tied up the government deposits.

The failure to recharter the first Bank of the United States left the field free to the state banks, which increased from 88 in 1811 to 246 in 1816, and expanded their bank note issues to \$100,000,000. These banks were organized on very defective credit principles, the loans being based heavily upon lands and government securities. The export of specie due to the adverse balance of trade made the situation still worse. The Treasury operations were thrown into confusion by the disordered currency. At this juncture, in the year 1816, the demand for a second Bank of the United States became strong enough to force Congress to grant a charter.

From its organization in 1816 down to 1834, the year in which the second Bank of the United States was refused an extension of its charter, the state banks grew in number. Good statistics are

not available as to their number, for no general reporting system existed and, moreover, through a peculiar policy of secrecy, several states concealed the operations of their banks. The available records, however, indicate that in 1829 there were 329 banks, the character of which varied greatly, depending upon state law, local conditions, and individual management.

After Jackson's re-election in 1832 he became more determined in his opposition to the second Bank of the United States and decided to sever relations between the government and the institution, removing the public deposits and putting them in state banks. These state banks, although selected with reasonable care and subjected to fairly strict conditions, were called Jackson's "pets," and political motives were alleged to have entered into their selection. The entire period from 1816 to 1837 was one of rapid development and speculative prosperity. Land speculation, internal improvements, and the development of cotton farming were particularly active features of finance, and banks in consequence sprang into existence in great numbers. The hope of procuring some of the redistributed public surplus during Jackson's administration was a further stimulus. By 1836 the number of state depository banks increased to 89 and by 1837 the state banks increased to 788, with a circulation of \$149,000,000.

Causes of Panic of 1837

In 1836 the Treasury issued the "spécie circular," an order to its public land agents to receive for the sale of public lands only specie, and to refuse the notes issued by the banks. The order aimed to repress land frauds, to discourage the extension of bank notes and bank credits, and to protect the Treasury. The circular restricted particularly the activities of western banks and their eastern agents. This restriction, in conjunction with the failure of a number of foreign banks and the failure of the crops between 1835 and 1837, precipitated a panic which had been brewing for some

time. When the transfer of public deposits was suddenly halted, banks and projects founded on the expectation of receiving these funds failed straightway and the government lost heavily. During the long period of depression that followed, the number of banks, after increasing to 901 in 1840, declined to 691 in 1843, and their circulation contracted from \$149,000,000 in 1837 to \$59,000,000 in 1843.

The Independent Treasury System

After the crisis of 1837 many projects were advanced to substitute for the banks some other form of financial institution as public depositories. Two national banks had failed for political reasons, and losses had been sustained by the Treasury during the intervening periods, 1812-1816 and 1832-1836, when it had used the state banks. After a long legislative struggle an independent treasury was created in 1840, the law having a "specie clause" to the effect that the government would accept only specie in payments to itself. The Whigs in 1842 repealed the Independent Treasury Act and attempted in vain to establish a national bank. The Democrats in 1846 re-established the Independent Treasury by legislation which permitted only specie and treasury notes to be received by the government, and public funds to be kept only in the Treasury, sub-treasuries, the mints, and the custom-houses. The Independent Treasury system worked fairly well during the period before the Civil War. The inauguration of the system was plainly forced by the abuses and failure of the banking system of the day, and was a protest both against the central national bank and the state bank systems. Before the Civil War the state banks had increased in number from 691 in 1843, to 1,601 in 1861; in circulation from \$59,000,000, to \$202,000,000; and in deposits from \$56,000,000, to \$257,000,000. Some states had developed a body of sound banking laws and methods of supervising their banks, thereby increasing their utility as commercial and public institutions.

Bases of Note Issue Before the Civil War

The period between 1790 and 1861 was one of experimental banking in a new country rich in natural resources and settled with an energetic, inventive, and independent people who worked things out for themselves locally. But the country was poor in specie, in loanable capital, in financial institutions, and in experience. Such a combination led to a wide variety of experiments which always sought a maximum of benefit from a minimum of specie. Banks of many kinds were developed, and four types of note issue stand out, based upon or protected by:

1. General assets.
2. A general safety fund.
3. Bond security.
4. The credit of the several states.

1. *General Assets.* Of the banks whose issues rested upon general assets, the best examples were those of New England. The original Bank of Massachusetts was of this type and was singularly free from legal limitations. Later laws restricted the amount of issue to a multiple of the capital and specified the minimum denomination of the notes, but no provision was made for the special protection of the notes. The banks were required to report their condition from time to time to the state. They grew up in a conservative area and were sounder than those in other parts of the country. As a result, in 1814 they alone of all banks did not suspend specie payments. In 1837 Massachusetts adopted a system of examinations by state bank commissioners. Though repealed in 1842, the system was readopted in 1851.

The banks of New England were modeled upon those of Massachusetts, and they maintained intimate relations with the banks of Boston. The Boston banks in 1818 instituted the Suffolk system of note redemption, in order to prevent the note issues of interior banks from driving out of circulation the issues of the sound Boston banks. This system required the country banks to

keep, in addition to a sum sufficient for the current redemption of its notes, a permanent deposit with the Suffolk Bank. The notes of any bank which refused to make this deposit were sent home for redemption. A large majority of the New England banks came into the system, some quite reluctantly, and the circulating notes of the area were thus brought to par in Boston. The bank notes were redeemed through this agency on an average ten times a year, and this redemption constantly tested the solvency of the issuing bank and kept the volume of issue elastic.

2. *Safety Fund.* The safety fund system was illustrated in New York. It was inaugurated at the instance of Governor Van Buren, in 1829, as a protection for notes only, but by accident the fund was made to cover deposits also. Each bank was to pay annually to the State Treasurer a sum equal to $\frac{1}{2}$ per cent of its capital until the payments aggregated 3 per cent. Any deficit, after the assets of a failed bank had been liquidated and the proceeds applied to its notes and deposits, was paid from this fund. In 1837 the law was changed to provide for the immediate payment of the notes of an insolvent bank whose debts in excess of assets were less than two-thirds of the bank fund. In 1842 the fund was specifically set aside for the redemption of bank notes alone, and the other liabilities of the bank were charges against the assets. Had the fund not been made to cover both notes and deposits, it would have succeeded, for calculation shows that the annual assessment required to pay the losses from 1829 to 1865 would have been less than $\frac{1}{4}$ per cent of the capital and $\frac{3}{8}$ per cent of the average circulation of the banks. The fund should have been proportioned to the volume of the note issue rather than to the capitalization.

3. *Bond Security.* The panic of 1837 proved the defects of the safety fund system of protecting bank notes as employed in New York State, and the next year the Free Banking Act was passed. Banking was "free" in the sense that any individuals or associations were free to open a bank and to issue notes upon

deposit with the State Comptroller of securities of the United States, or of New York, or of any other state approved by the Comptroller. After 1840 the securities of other states were not accepted. Provision was also made, though little used, for the issue of notes against deposit of approved mortgages. Though this method of note issue lacked elasticity, it was relatively sound, and in 1863 it became the model of the national bank note system. Many other states also adopted the method of protection by deposit of securities, but usually without due safeguards, so that in some states an endless chain of debt creation and note issue developed until the securities fell below par.

4. *State Credit.* The fourth system of note issue was based on state credit, that is, on the credit of banks owned and managed by the state. Though the Constitution forbade the states to issue bills of credit, in 1837 the Supreme Court decided that an issue by a bank owned in whole or part by the state was not thereby prohibited. Such banks had been in operation even before this date, but the experiences of Kentucky, Alabama, Mississippi, Florida, Illinois, Louisiana, and other states, with their note issues, were most unfortunate. On the other hand, the state bank of Indiana was very successful. It based its note on commercial assets and required the payment of its capital in actual cash, whether the subscriptions were by the state government or by private citizens. The state made good profits on its investment and its natural resources were developed very well indeed through the help of the bank.

Evils of Early Bank Note Issues

Prior to the year 1860 the state bank notes consisted of a heterogeneous currency, lacking all uniformity, under diverse systems of issue, with varying degrees of protection and of limitations on issues. The bank notes of the New York banks, where the banking law was rigidly enforced, attained wide circulation; the mutual redemption system in New England also gave cur-

rency to the notes of the stronger banks. With these and a few other exceptions, state bank notes enjoyed only a local credit.

As bank notes constituted practically the whole circulating media, the difficulties confronting travelers in procuring acceptable media for their expenses can readily be realized. The currency of the western states was so motley and contained so many doubtful notes that their recipient had to have almost the expert knowledge of a note-detector. The notes issued in one state were accepted at varying rates of discount in others, and the consequent losses were large. Exchange on eastern cities was quoted in the Mid-west at high premiums, ranging from 1 to 10 per cent. After its unfortunate experiences in the panic of 1837, the national government refused to accept bank notes and insisted upon specie in payments to itself. Noteholders, particularly the poorer and more ignorant classes into whose hands the worst notes drifted, lost heavily from failures of the issuing banks. In 1861 a writer in the *Chicago Tribune* said the "bank nuisance had become unbearable." According to that writer many banks made it their chief business to manufacture and put out as large an amount as they could by any contrivance keep in circulation, regardless of the dearth of reserves. Some were "merely banks of circulation without capital and doing no business at their nominal locations," the notes being issued at goodly distances from the place of redemption so as to delay presentation.

Since the notes circulated some time before redemption, they became dirty, greasy, mutilated, and worn—facts which made them not only unfit for circulation but also facilitated counterfeiting. It was necessary to inspect all bills carefully and the receiving tellers of banks had to be very expert and acute to recognize and reject the spurious notes. Publications, known as "Counterfeit Detectors," with weekly supplements, found a useful place in every counting-room. A writer in 1863, examining these "Detectors," claimed that there were in existence nearly 1,600 banks issuing daily 10,000 different kinds of notes,

a large portion having been copied and issued by counterfeiters.

Considering the number of issues, the different forms and pictorial designs, the various denominations, the numerous counterfeits and raised notes, and the notes of fraudulent and failed banks, that formed the currency of the day, it is not surprising that reform was advocated. The poorer and more ignorant classes, who were least able to refuse tendered notes and to detect and reject worthless ones, suffered most and yet could not make their protests heard.

During periods of depression the quantity of note circulation was considerably decreased by failures of issuing banks, but prosperous years gave birth to new issues. The volume in circulation was also summarily increased or decreased by fits of legislative enactments permitting or suppressing note issues.

Another evil of the day inherent in the bank note system was the speculation and traffic in bank notes. Speculators would buy up certain issues at discounts and carry them to redemption points or put them out in regions where they circulated at higher values; they would also speculate in the changes in note values effected by time.

In 1861 the risks and difficulties of note circulation were increased by the suspension of the banks, a suspension which relieved them from the test of redeeming in specie their issues on presentation, but allowed them to redeem with the fluctuating greenbacks, if redeemed at all. A sound, sufficient, and uniform currency was also rendered necessary by the government's suspension of specie payments and by the passage of the Internal Revenue Bill, for the collection of revenues would have been farcical or unequal if the revenues could have been paid in the existing legal tenders or bank notes.

Proposed Advantages of National Bank Note Issue

In his finance report of 1861, Secretary Chase first stated the advantages to be derived from "the preparation and delivery to

institutions and associations of notes prepared for circulation under national direction and secured as to prompt convertibility into coin by the pledge of United States bonds." The advantages claimed were:

1. Uniformity in currency.
2. Uniformity in security.
3. Effectual safeguard, if effectual safeguard is possible, against depreciation.
4. Protection from losses on discounts and exchanges.
5. A large demand for government securities.
6. Increased facilities for obtaining war loans.
7. Some alleviation of the burdens on industry, through a diminution of the rate of interest or a participation in the profit of circulation without risking the peril of a great money monopoly.
8. Increased security to the Union, springing from the common interest in its preservation, created by the distribution of its stocks to associations throughout the country as the basis of circulation.
9. Easy and desirable method of accomplishment through voluntary action of existing institutions.

In 1862 Chase drew attention to the further advantage that the note-issuing banks would provide the government with safe and convenient agencies for the deposit of government moneys. His two fundamental motives were: to create a safe uniform currency, and to secure a market for government bonds. He opposed making the greenbacks legal tender and objected to their issue, suggesting as an alternative the issue of bond-secured bank notes. The plan necessitated the nationalization of the banks, a step which the banks strongly opposed in Congress on the grounds that: (1) nationalization would force the state bonds already deposited against circulation on the market in competition with United States bonds; (2) the total note circulation was but \$200,-

000,000, and the market created for bonds would therefore be negligible; (3) nationalization would take place slowly and the government would secure no considerable relief for two or three years.

The National Banking Act

The National Banking Act became a law on February 25, 1863. On October 1 the Secretary reported the organization of but 66 national banks, and these were small institutions with the foundation of which the leading financiers had nothing to do. During the early part of 1864 Chase urged a prohibitive tax on state bank notes as a means of forcing the state banks to nationalize, the argument being based on:

1. The desirability of an exclusive national currency.
2. The support which the bond sales would afford to the credit of the government.
3. The convenience and utility of the national banks to the government.

On June 3, 1864, the act was amended, the new act constituting what is commonly called the National Banking Act. On March 3, 1865, an act was passed imposing a tax of 10 per cent on the amount of notes issued by state banks after July 1, 1866. Up to November 15, 1864, only 584 national banks had been organized, with \$81,961,450 capital. The effect of the tax by October 1, 1865, was to raise the number of banks to 1,566, with \$276,219,450 capital. Though during the Civil War the national bank system failed to provide either a uniform currency (which seems to have been Chase's main motive), or a market for government bonds, after the amendment of March 3, 1865, the plan quickly established a safe and uniform note circulation and a permanent market for government bonds.

The Growth of the National Banking System

The nationalization of those state banks which desired to continue to issue bank notes was rapidly consummated during the

years 1865 and 1866. Since that time the number of banks has increased eightfold, with periods of growth between 1871 and 1875, 1880 and 1892, and 1900 and 1919, and periods of contraction between 1867 and 1869, 1876 and 1879, 1894 and 1898, and in 1916. The most rapid expansion occurred after 1900, at which date the minimum required capitalization, as well as the tax on circulation, was reduced.

The volume of national bank notes is not an adequate index to the growth of the banks. The rapid growth between the dates 1877 and 1882 was due to the expansion of the country; their growth between 1895 and 1914 was also due to the expansion of the country, but more particularly, after 1900, to the lower capital requirements for national banks. The two periods of their decline were between the years 1883 and 1891, when the government debt was being paid off, and between 1915 and 1917 when the Aldrich-Vreeland currency was being contracted.

The two best indexes of banking activity are the deposits and aggregate resources. Except during the panic periods of 1873-1878, 1883-1887, and 1903, our banks have grown in number and in the extent of their operations, and the panic of 1907 and the depression of 1913-1914 retarded but did not reverse this tendency.

The above facts are presented more plainly in the table on page 234.

The comparative growth of national banks and the state banks and trust companies is tabulated on page 433. Such comparisons are somewhat unfair to the national banks, since their minimum capitalization is higher than that of state banks and the increase in the number of small banks does not affect the national bank columns. Possibly a fairer comparison of the growth of the two classes of institutions would be as between state and national banks having capitalization above the former minimum of \$50,000.

GROWTH OF THE NATIONAL BANKING SYSTEM

NUMBER OF BANKS		TOTAL RESOURCES		DATE	BANK NOTES		DEPOSITS	
Increase	Decrease	Increase (In millions)	Decrease (In millions)		Increase (In millions)	Decrease (In millions)	Increase (In millions)	Decrease (In millions)
134				1863				
450				1864				
1,007				1865				
56				1866				
	9			1867				
	9			1868				
	9			1869				
7				1870				
158				1871				
158				1872				
36				1873				
48				1874				
64				1875		\$5.0		
	5		\$88	1876		20.6		\$44
	7		51	1877	\$3.6			5
	27		24	1878	3.6			0
	3	\$269		1879	20.1		\$254	
45		16		1880	1.4			57
60		323		1881	18.6		239	
146		41		1882	0.7		51	
220			27	1883		12.2		71
150			93	1884		22.2		74
56		153		1885		8.5	127	
141		81		1886		23.8	73	
192		107		1887		26.8	85	
90		195		1888		36.5	232	
168		183		1889		34.5	115	
248		143		1890		18.8	73	
127		72		1891		2.3	14	
93		297		1892	1.2		171	
8			401	1893	34.4			314
	50	364		1894		2.1	277	
	42		50	1895	8.2			27
	36		160	1896	21.8			102
	65		558	1897		7.6	256	
	19	298		1898	17.5		237	
2		647		1899	3.9		423	
334		398		1900	85.1		73	
344		647		1901	107.1		442	
397		418		1902	20.7		289	
469		197		1903	39.7			28
346		665		1904	37.6		263	
363		497		1905	68.0		314	

GROWTH OF THE NATIONAL BANKING SYSTEM—*Continued*

NUMBER OF BANKS		TOTAL RESOURCES		DATE	BANK NOTES		DEPOSITS	
Increase	Decrease	Increase (In millions)	Decrease (In millions)		Increase (In millions)	Decrease (In millions)	Increase (In millions)	Decrease (In millions)
366	\$ 544	1906	\$ 59.0	\$ 425
425	374	1907	28.3	173
222	637	1908	61.2	194
151	546	1909	34.0	384
192	253	1910	24.0	137
113	557	1911	14.6	331
97	478	1912	11.1	358
86	175	1913	10.7	137
61	446	1914	367.5	247
48	313	1915	\$315.3	343
.....	26	2,131	1916	48.4	1,537
62	2,374	1917	14.5	1,595
94	1,549	1918	7.4	1,476
135	2,960	1919	4.9	1,720

INCREASE IN NUMBERS OF BANKS HAVING
CAPITAL OF \$50,000 AND OVER

	From 1877 to 1888	From 1888 to 1899	From 1899 to 1909
State banks.....	409	535	1,032
National banks.....	1,064	435	1,194

Movement to Reform National Banking System

Certain defects in the national banking system appeared early, particularly in the geographical distribution of the banks and in the reduction of national bank note circulation as the national bonds were paid off. The inability of the system to meet and stem panics had been demonstrated in 1884, 1890, and 1893. During 1893 an acute scarcity of currency started the reform movement which has culminated in the federal reserve. At the meeting of the American Bankers' Association at Baltimore in

1893 a plan for a currency protected by a joint guaranty fund contributed by all the banks was advocated; this "Baltimore plan" of "currency reform" was based on the Canadian system. In 1896 the reform of the banking currency became involved with the question of bimetallism versus the gold standard. The Indianapolis Currency Commission, a body composed of representatives of boards of trade and commercial organizations, recommended the establishment of the gold standard, the segregation of the reserve gold fund against greenbacks and its automatic repletion by issue of bonds, and the issue of bank notes based upon commercial paper and protected in several ways. The Gold Standard Act of 1900 accomplished the first two of these recommendations, and further provided for the refunding of the government bonds into 2 per cent consols and the establishment of national banks with a smaller capitalization than had been allowed theretofore, and permitted the issue of notes up to 100 per cent instead of 90 per cent of the par value of the bonds. This legislation temporarily satisfied the demand for currency, but it did not remedy any of the inherent defects of the national bank plan.

The aim of reform henceforth was to reorganize the system completely. In 1901 and succeeding years the Banking and Currency Committee of the House of Representatives presented bills to establish an elastic currency and a centralized banking system. Several banking students advocated in private circulars, in the press, and in Congressional bills, various schemes of centralization.

The movement thus well under way was precipitated by the panic of 1907. In the spring of 1908 the Banking and Currency Committee of the House reported the Fowler Bill advocating the issue of currency based on commercial paper, and the Senate Committee on Finance reported the Aldrich Bill advocating the issue of notes against other kinds of bonds than United States bonds. As a compromise, the Aldrich-Vreeland Act of May 30,

1908, was passed, providing for the issue of currency based on commercial paper by associations of banks known as "national currency associations," and for the issue of national bank notes based on deposits of special kinds of municipal and other bonds.

This act, which was regarded as a makeshift on the eve of a presidential election, provided for a National Monetary Commission with wide powers to make an investigation of the currency and banking situation and report to Congress. The commission made an extensive investigation and published an excellent series of books with the object of helping to educate the business and financial world in the banking problem. In 1910 Senator Aldrich presented in a bill the outlines of the Aldrich or Monetary Commission plan. A Republican Congress meanwhile had become Democratic in character and the Aldrich Bill in consequence died in committee. The Democratic Banking and Currency Committee of the House, out of the vast amount of information assembled, and with the help of the Aldrich, Fowler, Muehlman, and other bills, prepared, during 1912 and 1913, a preliminary draft of what later became the Federal Reserve Act. After three months of consideration and amendment the measure passed Congress and was signed by the President on December 23, 1913. It is known as the Currency Act, or more commonly and properly the Federal Reserve Act, and is the most important piece of financial legislation since the National Bank Act of 1863.

CHAPTER XIII

FEDERAL RESERVE DISTRICTS AND MEMBERSHIP

The Federal Reserve Districts

The Federal Reserve Act provides for the division of the country into not less than eight nor more than twelve Federal reserve districts, each with its own reserve bank, "individually controlled and holding the fluid funds of the region in which it is organized, and each ordinarily dependent upon no other part of the country for assistance." The factor of centralization is the Federal Reserve Board.

The regional idea is a fundamental feature of the system, and was hotly debated in Congress. Those in favor of the idea maintained that no area the size of the United States was or could be under one central bank without prejudice to some areas, since such wide diversities of banking needs existed, and that the regional plan would provide greater adaptation to regional characteristics and would give local control and responsibility, thus not only serving local financial needs better but being politically expedient since local control would allay jealousy of Wall Street and other distant money marts. The central banks of England, France, Germany, etc., correspond with the several federal reserve banks so far as area and local adaptations are concerned. Undoubtedly one deep-seated motive behind the federal reserve legislation was a decentralization of the money power centering in New York. The federation of the reserve banks in the Federal Reserve Board clothes the system with ample powers to give uniformity and unity of action where needed, and at the same time local autonomy enough to remove the system from politics, which defeated our two earlier attempts to found central banks.

The opponents of the regional plan argued that it could not effect uniformity of interest rates, equal facilities for discounting, nor uniform banking practice; that the banks would not work together; that, as the system would be unreasonably expensive, member banks would not get dividends on their stocks; that there were too many reserve banks; and so on. These arguments have since been disproved by actual operation.

Although the federal reserve system is regional, some complaint has been raised that because the reserve banks are bankers' banks, which do not deal directly with individuals, the system is still too highly centralized and too remote from the people. This contention has some basis of fact, in so far as the depositors and customers of the reserve banks are mostly banks and the only direct dealings of the reserve banks with the people are the open-market transactions in commercial paper, gold, and securities. Certain European central banks, it may be noted, allow direct access to the public. In actual practice, however, the privilege is infrequently used in the case of those European banks, and the great bulk of private business is done with local banks. The competition of our reserve banks with the local banks extends the benefits of a central bank to the public, for by going into the market the central bank can break any temporary obstacles to the flow of benefits from the local banks.

Boundaries of Federal Reserve Districts

To put the federal reserve system into operation the Reserve Bank Organization Committee was constituted, consisting of the Secretary of the Treasury, the Secretary of Agriculture, and the Comptroller of the Currency. This committee made a trip through the United States for the purpose of hearing arguments and assembling data to determine the number and boundaries of the districts, as well as the federal reserve cities. Two provisions of the law were: that the number of districts be not less than eight and not more than twelve, and that the districts con-

form to the convenience and customary course of business of the country.

The aim of the committee was to create a certain degree of equality or strength among the districts rather than to allow the New York district to overshadow weaker districts. As equality is impossible unless each district is laid out so that its area is inversely proportional to the number and strength of its banks, and as the minimum capitalization of a reserve bank was fixed by the act at \$4,000,000, and was to be subscribed primarily on the basis of 6 per cent of the capital and surplus of the member banks, therefore in the South and West, where banks are small and few in number, the district had to embrace a large territory. The committee laid out the eastern districts on lines that will to a large extent probably prove permanent, but the western and southern districts will probably be rearranged as the country develops. In hearing arguments and assembling data the committee discovered an intense local jealousy among the candidate cities. To appease this jealousy and to effect as great local control as possible, the committee decided to establish twelve districts, as nearly as possible in their final form, so as to allay efforts to divide and rearrange them later.

The act provides that "the districts thus created (that is, by the Organization Committee) may be readjusted and new districts may from time to time be created by the Federal Reserve Board, not to exceed twelve in all." As the Organization Committee fixed twelve districts at the beginning, the board has no power to create new districts, but only to readjust boundaries of those already existing. In making such readjustments the board has transferred certain banks in Louisiana from the Dallas district to the Atlanta district, and certain banks in the new county Humphreys from the Atlanta to the St. Louis district, and in Fairfield County, Connecticut, from the Boston to the New York district. Appeals for transfer by other areas have been denied by the board, and it is probable that the districts are now quite

permanently fixed. Appeals by Pittsburgh to be made a federal reserve city instead of Cleveland, and by Baltimore to supersede Philadelphia, and by bankers and others to abolish certain districts, have been denied by the board on the ground that it has no power to change the federal reserve cities or to abolish any of the districts.

The districts are numbered and each reserve bank is named after the city in which it is situated, as the Federal Reserve Bank of Boston, and the like.

The boundaries of the districts and the federal reserve cities are given on Figure 4.

Domestic Branches of Federal Reserve Banks

The Federal Reserve Act, as amended June 21, 1917, provides that the board may permit or compel a federal reserve bank to establish branches within its district or within the district of any reserve bank which may have been suspended. Such branches, subject to such rules and regulations as the Federal Reserve Board may prescribe, are operated under the supervision of a board of directors, consisting of not more than seven nor less than three members of whom a majority of one are appointed by the federal reserve bank of the district, and the remaining directors by the Federal Reserve Board.

The volume of business done by a branch may sometimes equal or even exceed that of the parent bank. The establishment of branches makes it possible for the board to appease local jealousy against a federal reserve city and to bring the facilities of the reserve bank nearer the member banks, such proximity being particularly desirable in the larger western districts. The board has also found it advisable to establish branches for the purpose of specially catering to the state banks and inducing them to join the federal collection system.

Under the authority of the board branches have been established as follows:

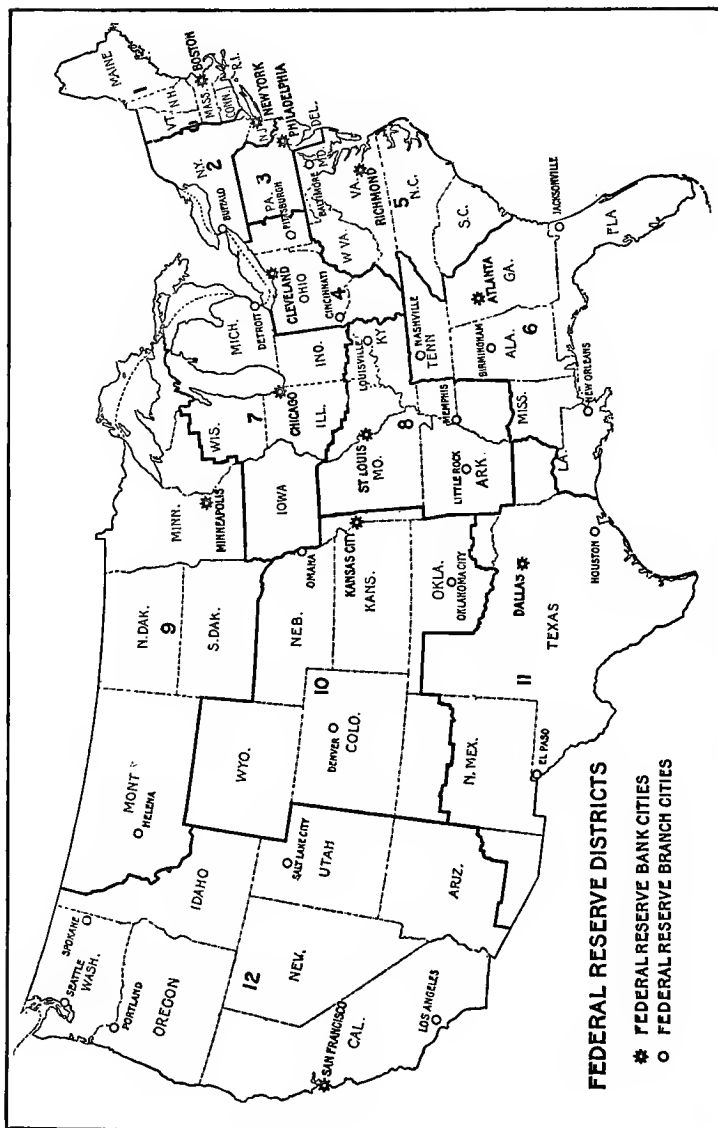

Figure 4. The Federal Reserve Districts

District No.	Federal Reserve City	Branches
1	Boston	None
2	New York	Buffalo
3	Philadelphia	None
4	Cleveland	Pittsburgh, Cincinnati
5	Richmond	Baltimore
6	Atlanta	New Orleans, Jacksonville, Birmingham, Nashville
7	Chicago	Detroit
8	St. Louis	Louisville, Memphis, Little Rock
9	Minneapolis	Helena
10	Kansas City	Omaha, Denver, Oklahoma City
11	Dallas	El Paso, Houston
12	San Francisco	Seattle, Portland, Spokane, Salt Lake City, Los Angeles

In addition to their branches the reserve banks establish temporary or permanent agencies in such cities in their districts as may require special services, such as collecting checks or making loans on warehouse receipts. The St. Louis reserve bank, for instance, established such an agency in Memphis in 1915 as a convenience to the banks of that area in handling cotton rediscount paper. Such agencies are less expensive to operate than branches with their completely equipped offices, vaults, and full staff of officers; moreover an agency is usually the forerunner of a branch to be opened when the volume of business warrants the expense.

Two types of organization exist among the branches. The older, like the New Orleans branch, has a definite area allotted to it; the capital subscriptions by the member banks of this area are regarded as the theoretical capital of the branch, upon which its earnings are estimated; and the members within that area are required to deal with the branch. The later type, like the Spokane branch, has no definite area or capital assigned to it, but is regarded rather as an office of the reserve bank; members are not

required to deal solely with this branch. A collection zone is allotted to each branch, and checks drawn upon banks in this zone may be sent to the branch by any member bank, thus saving time in transit and reducing the float. The resulting credit is reported by the branch to the parent bank. Member banks send their collections either to the parent or to the branch. They send their offerings for discount, however, to the parent bank, but upon application a member who is in the allotted collection zone may send discount offerings to the branch. Daily reports of each member's account are forwarded to the parent by the branch.¹

Foreign Branches of Federal Reserve Banks

The Federal Reserve Act authorizes any reserve bank, with the consent of the Federal Reserve Board, to establish banking accounts, appoint correspondents, and set up agencies in such foreign countries as it may deem best for the purpose of purchasing, selling, and collecting bills of exchange, and further authorizes the reserve bank to buy or sell, with or without indorsement, through such correspondents or agencies, bills of exchange arising out of actual commercial transactions, and to open and maintain banking accounts for such correspondents or agencies. These powers are ample for carrying on foreign business.

The Federal Reserve Board was reluctant to let the reserve banks establish such agencies abroad, on the grounds that the condition of business in foreign markets was too disturbed by the war, that foreign operations should not be engaged in until the domestic aspects of the federal reserve system had been fully developed, and that pioneering should be done rather by member banks. On February 13, 1917, however, the Philippine National Bank was designated by the reserve bank of San Francisco as its agent for the Philippine Islands. The arrangement includes the maintenance of reciprocal accounts, the collection of drafts and claims and, when desired, the purchase of bills by either bank for

¹ See Federal Reserve Bulletin, Aug. 1917, p. 586.

the other or from the other for its own account, if conditions favor and such business is deemed mutually desirable. When as a result of the war the United States became a creditor nation and financial operations of huge size developed between this country, England, and France, the board permitted the reserve bank of New York to appoint as its foreign agents the Banks of England and of France (December 24, 1916, and February 28, 1917), and to become the American agent of these banks. Other federal reserve banks may participate in the agency relationship with these foreign banks upon the same terms and conditions as the New York bank, if they so desire. It is probable that the system will develop more and more along the line of the establishment of such foreign agencies. The New York bank has also entered upon mutual agency relations with the Bank of Japan (January 23, 1918), and has now, or has had during the war, relationships with De Nederlandsche Bank, Norges Bank, Sveriges Riksbank, De Javasche Bank, and with the governments of India, Argentina, Bolivia, and Peru. Most of these relationships were arranged to stabilize foreign exchange. The item, Gold Held with Foreign Agencies, appeared for the first time in the statement of the federal reserve banks under the date of June 23, 1917.

Membership in Federal Reserve System

The sponsors of the federal reserve system hoped to have it include all national banks and all state banks and trust companies of size and importance. The act required each national bank to signify to the Organization Committee its acceptance of the terms and provisions of the act, within sixty days of its passage. Any national bank failing thus to signify its acceptance was to cease acting as a reserve agent upon thirty days' notice from the committee or Federal Reserve Board; and if any national bank failed within one year after the passage of the act to become a member bank, it forfeited its national charter. As soon as the districts were determined, the committee required the members to sub-

scribe to the capital of the federal reserve bank. Only fifteen banks refused to join, and as these were either small, or in process of liquidation or consolidation, or had been organized so recently that they had not had time to signify their acceptance, acceptance of the system was practically unanimous.

The act provides that state banks and trust companies may apply to the Federal Reserve Board for membership in the federal reserve system and may buy stock of the reserve bank. Such a bank, when admitted, must comply with the capital and reserve requirements of national banks and have a paid-up unimpaired capital sufficient to entitle it to become a national bank. In acting upon such applications the board considers the financial condition of the applying bank, the general character of its management, and whether or not its corporate powers are consistent with the requirements of the Federal Reserve Act.

Legal Requirements of Membership

State banks becoming members of the federal reserve must conform to the laws imposed upon national banks, which prohibit them from lending on or purchasing their own stock, and which relate to the withdrawal or impairment of their capital and to the payment of unearned dividends. Their officers and employees are subject to the national bank statutes covering penal offences. They are required to present to the federal reserve bank, not less than three times a year and on dates fixed by the Federal Reserve Board, reports of their condition and of the payment of dividends. They are also subject to examination made under direction of the board or of the reserve bank by examiners selected or approved by the board. In lieu of this, however, the reserve bank may accept the examinations made by the state authorities. The board may also order special examinations. The expenses for these various federal examinations are assessed upon the bank.

The Federal Reserve Board has power, after a hearing, to require any member to surrender its stock in the reserve bank

and forfeit its membership, if the member fails to comply with the federal laws or regulations. A state member bank or trust company may withdraw its membership at will, after six months' notice of its intention has been filed with the board. The board deals with these applications for withdrawal in the order in which they are filed. After indebtedness to or from the reserve bank has been adjusted the withdrawing member is entitled to a refund of its subscription at par and to the repayment of its deposits with the reserve bank. Subject to the provisions of the Federal Reserve Act and to the regulations of the board, a state bank or trust company becoming a member retains its full charter and statutory rights as a state institution and may continue to exercise all the corporate powers granted by the state, except that no federal reserve bank is permitted to discount for such bank or trust company the paper of any one borrower who has borrowed from such bank or trust company in an amount greater than 10 per cent of its capital and surplus. The discount, however, of bills of exchange drawn against actually existing value and the discount of commercial or business paper actually owned by the person negotiating the same are not considered as borrowed money within the meaning of this clause. The reserve bank requires a signed statement from such member seeking to discount its paper, that it is not liable in excess of these amounts. Overcertification of checks by a state bank or trust company member is prohibited under penalty of forfeiture of membership.

Procedure in Applying for Membership

The procedure for acquiring membership in the federal reserve system is as follows:

1. A resolution by the board of directors, upon a form furnished by the federal reserve agent, applying for stock in the federal reserve bank. Accompanying the application and as a part of it must be a certified statement of the condition of the applying bank or trust company,

a copy of the charter and articles of incorporation, together with any amendments thereto, and a statement containing certain additional information requested. The State Banking Department is also requested to furnish the federal reserve bank with two copies of its last report of examination and with copies of all correspondence relating thereto.

2. Examination by an examiner from the staff of the federal reserve bank.
3. Sending of the application to the Federal Reserve Board, which determines whether or not it shall be approved, and if approved, upon what conditions.
4. If approved, payment of the amount required on the capital stock subscription and the making of the necessary reserve deposit.²

Growth in State Bank Membership

After the passage of the Federal Reserve Act the state banks and trust companies did not seek admission to the federal reserve system as quickly as was expected. Many banks objected outright to the system and other factors also caused delay. For one reason, the system was new and difficult to understand, and it took time to educate the state bankers to the desirability of joining. For another reason, many banks preferred to wait until the workability of the system had been proved. Laws had to be passed in some states enabling their banks to join, and in others the bank laws were liberalized and made equal to the national law, so as to keep the state banks from joining the national system. The long-standing jealousy which existed between the state and national banks also kept them aloof, and the permission granted to national banks to do trustee business, to make loans on real estate, and to act as insurance agents further intensified the competition and animosity between these two groups of institutions.

² See Federal Reserve Bulletin, Aug. 1917, p. 592.

The larger state institutions joined first. Up to February 1, 1921, 1,501 state banks and trust companies, with aggregate resources of \$10,345,000,000, had become members of the federal reserve. The war was a strong factor in securing state bank members. The President, the Council of National Defense, the Federal Reserve Board, and certain state bank superintendents urged the eligible state institutions to join the system and thereby unify and strengthen it for the heavy burdens of war financing. Legislation to compel them to join was advocated by some parties. The main influence operating to extend the membership is the recognition of the benefits derived from the system and the removal of the most serious objections to it.

The growth in the number of member banks in the federal reserve system is shown in the following table:

GROWTH OF FEDERAL RESERVE SYSTEM

Date	National	State	Total
1914 December 31.....	7,584	8	7,592
1915 June 30.....	7,607	17	7,624
December 31.....	7,614	32	7,646
1916 June 30.....	7,581	34	7,615
December 31.....	7,590	38	7,628
1917 June 30.....	7,631	56	7,687
December 31.....	7,683	250	7,933
1918 June 30.....	7,713	523	8,236
December 31.....	7,776	936	8,712
1919 June 30.....	7,819	1,047	8,866
December 31.....	7,888	1,181	9,069
1920 June 30.....	8,030	1,375	9,405
December 31.....	8,130	1,487	9,617

Objections to Membership

The board has tried to induce the state banks to join by meeting their objections and removing the obstacles. For instance,

the expense and bother of examinations by both state and national examiners have been saved by co-operative arrangements. Only such reasonable standards of admission are enforced as will protect the national banks, whose membership is obligatory; and only such regulations govern their conduct as will insure a reasonable conformity to the fundamental principles of the system. To meet the wishes of the state banks, the board had most of its regulations enacted into law on June 21, 1917, so as to give them permanent stability.

It is not expedient to admit all state institutions. Very small banks, though great in number and in the combined amount of their resources, would prove an element of weakness, for too large a part of their funds is loaned on real estate or other non-commercial security. Likewise savings banks are non-commercial institutions, as are trust companies that do no commercial bank business. Private banks are excluded because of the character of their business or their lack of regulation. Mutual savings banks without capital stock are excluded because they can make no subscription to federal reserve bank stock.³

The following are some of the positive objections that have been offered to membership in the system, objections which have not been or cannot be eliminated by amendments to the act:

1. Extra clerical expense.
2. Lack of rediscountable paper and want of provision for loans by the reserve bank on securities collateral.
3. Too much regulation, interference, and federalization.
4. Loss of exchange under "par collection" system.
5. Loss of interest on reserve balances.
6. Limitations on loans.
7. Losses on dividends on federal reserve bank stock.

³ Effort was made in 1919 to get Congress to authorize the admission of mutual savings banks and, in lieu of the capital stock subscription, to require them to deposit 3 per cent of their surplus fund, to be adjusted annually, and an additional sum of not exceeding 3 per cent upon call, upon which they were to be paid $4\frac{1}{2}$ per cent interest. This measure was favored by the American Bankers' Association, the United States Council of State Banking Associations, and others, but failed to pass.

8. Political character of the Federal Reserve Board and of the Comptroller of the Currency.
9. Higher reserve requirements.
10. Less ready access to the Comptroller than to the State Banking Department.
11. Personnel of the Board and Comptroller.

An examination of these objections will show that some of them are trivial and sentimental and that others have been disproved by the facts. For instance, the objection that a great deal of red tape is involved in doing business with the federal reserve bank is not true; the federal reserve banks are conducted upon a strictly business basis, and transactions with them involve little if any more red tape than with another bank.

Reasons for Membership

The following are some of the reasons prompting state institutions to join the system:

1. The state institution retains all its charter and statutory powers and in addition enjoys the advantages of the reserve system.
2. The economies of the par collection system, namely, the collection of its items at par, the economy of time, the closing of correspondent balances, the easy transfer of funds by draft or telegraph, the shipment of funds without cost, etc.
3. Ability to borrow from the reserve bank at lower rates than elsewhere, and with sure accommodation.
4. Ability to carry with safety substantially lower excess reserves, and to invest these in rediscountable earning assets.
5. The rediscount privilege, and the security it offers against panics.
6. The moral obligation to contribute to the strength and

unity of the banking system, particularly in time of war.

7. The privilege of securing postal savings deposits and other government deposits.
8. Larger deposits from member correspondents permitted to members.
9. The prestige of examinations made under the supervision of the federal government.
10. Advertising value of membership in the system.
11. Better price for the acceptances of member banks.
12. The special services which the federal reserve banks are developing for their member banks free of charge, such as purchasing and caring for commercial paper for account of the members, etc.

The federal reserve banks have striven since the burden of the war was lifted to establish personal relations between the officers of the central and member banks, especially those situated outside the reserve city. To acquaint the members with the various services of the federal reserve bank and to explain the nature of its operations, member bank officers have been invited to the reserve bank in groups of, say, twenty-five, for the purpose of discussing banking operations, making suggestions for the improvement of the service, visiting the various departments, and outlining the policies of the reserve bank. The New York bank has established a "member bank relations department," with traveling representatives who visit each member at least once a year and thus come into direct contact with its owner customers.

New Powers of National Banks

The Federal Reserve Act and amendments also broadened the powers of national banks, so as to put them more nearly on the same plane of competition with the state banks. Some of these acquired powers are:

1. *To Act as Insurance Agent.* Any national bank in a town

or city with a population of less than 5,000 may act as agent for an insurance company authorized to do business within the state. In this capacity the bank may solicit and sell insurance and collect premiums on policies issued by such company, and receive therefor such lawful fees as may be agreed upon. The bank is prohibited from assuming or guaranteeing the payment of any premiums on policies so issued, or from guaranteeing the truth of any statement made by an insured person in filing his application for insurance. These powers must be exercised under the regulations made by the Comptroller of the Currency.

2. *To Act as Real Estate Loan Broker.* National banks located in places with a population not exceeding 5,000 may act as broker or agent in making or procuring loans on real estate and may receive reasonable fees or commission for such services. The real estate must be located within 100 miles of the place in which the negotiating bank is located. The bank must make the loans subject to the regulations of the Comptroller of the Currency and cannot guarantee either their principal or interest.

3. *To Act as Trustee and Fiscal Agent.* The Federal Reserve Board is authorized to grant by special permits to national banks applying therefor, when not in contravention of state or local law, the right to act as trustee, executor, administrator, or registrar of stocks and bonds, under rules and regulations prescribed by the board. This law gave national banks the power to compete with trust companies which do commercial banking. The law of some states definitely prohibited national banks from doing trust business, others clearly permitted it, while still others had doubtful laws on the subject. After the passage of the federal statute some states of the first group passed laws enabling national banks to engage in trust business; in others the efforts at similar legislation failed. In some states the trust companies became very hostile and contested in court whether the trust clause—Section 11 (k)—of the act is constitutional, and whether the exercise of such powers in that state was in contravention of the state law. Test

cases were carried to the Supreme Court from Michigan, and the constitutionality of the law was upheld (*Fellows v. First National Bank*, June 11, 1917). The board does not grant such power unless it is plainly within the law of the state, and unless it appears that the granting of the power is to the best interests of the applying bank.

The trust company section of the American Bankers' Association, as well as other interested parties, felt that trust funds of national banks should be segregated from their commercial funds and the two businesses handled separately, as is required by law in most states; otherwise, instead of Section 11 (k) simply putting national banks on the same competitive basis with state banks and trust companies, the advantage would be with the national banks. On September 26, 1918, the so-called Phelan Bill became law, and among its various sections is one amending Section 11 (k) of the Federal Reserve Act, to the following effect:

That the Federal Reserve Board has power to grant by special permit to national banks applying therefor, when not in contravention of state or local law, the right to act in any fiduciary capacity in which state banks, trust companies, or other corporations which come into competition with national banks are permitted to act under the laws of the state in which the national bank is located.

Whenever the laws of such state authorize or permit the exercise of any of these powers by its institutions which compete with national banks, the granting to and the exercise of such powers by national banks shall not be deemed to be in contravention of state or local law within the meaning of this act.

National banks exercising any of these fiduciary powers must segregate all assets held in any fiduciary capacity from its general assets and keep a separate set of books and records for these transactions, which books and records must be open to inspection by the state authorities to the same extent as the books and records of those operating under state law. This amendment does not authorize state authorities to examine the books, records, and assets of the national bank when such assets are not thus held in trust.

No national bank may receive in its trust department deposits of current funds, subject to check, or the deposit of checks, drafts, bills of exchange, or other items for collection or exchange purposes. Funds deposited or held in trust by the bank awaiting investment must be carried in a separate account and not be used by the bank in the conduct of its business, unless it first sets aside in the trust department United States bonds or other securities approved by the Federal Reserve Board.

In the event of the failure of such bank the owners of the funds held in trust for investment shall have a lien on the bonds or other securities so set apart, in addition to their claim against the estate of the bank.

Whenever the laws of the state require corporations acting in a fiduciary capacity to deposit securities with the state authorities for the protection of private or court trusts, national banks so acting shall be required to make similar deposits, and the securities so deposited shall be held for those purposes, as provided by the state law.

National banks in such cases shall not be required to execute the bond usually required of individuals, if state corporations under similar circumstances are exempt from this requirement.

National banks are authorized to execute such bond when so required by the laws of the state.

In case the laws of the state require a corporation acting in a fiduciary capacity to take an oath or make an affidavit, the president, vice-president, cashier, or trust officer of such national bank may take the necessary oath or execute the necessary affidavit.

It is unlawful under penalty for any national bank to lend any officer, director, or employee, any funds held in trust under powers conferred by this act.

In passing upon applications for permission to exercise the above powers, the Federal Reserve Board may take into consideration the amount of capital and surplus of the applying bank, whether or not such capital and surplus is sufficient under the circumstances of the case, the needs of the community to be served and any other circumstances that seem to it proper, and may grant or refuse the application accordingly. No permit shall be issued to a bank having a capital and surplus less than the capital and surplus required by the state law of state banks, trust companies, and corporations exercising such powers.

It will be observed that the purpose of this law is to put national and state banks on the same competitive basis and hedge them about with the same safeguards.

4. *To Handle Savings Deposits.* The act distinguished between demand and time deposits, and fixed the required reserve against the latter at a very low rate. It is now 3 per cent. Heretofore it had been quite impossible for a national bank to handle savings accounts except through an affiliated savings bank organized under state law.

5. *To Lend on Real Estate Security.* State banks had enjoyed a competitive advantage in their powers to loan on real estate security; as a result they flourished in agricultural regions where national banks could not. This inequality was reduced by the act, which permitted national banks not situated in central reserve cities to make loans on improved and unencumbered farm land situated in its federal reserve district or within 100 miles from the bank, irrespective of district lines, and to make loans on improved and unencumbered real estate within 100 miles of the bank, irrespective of district lines. No loan may be for a longer time than five years, and no loan on real estate as distinguished from farm land may be for more than one year. No loan may exceed 50 per cent of the actual value of the property offered as security. The total of the loans of this character may not exceed 25 per cent of the bank's capital and surplus, or $33\frac{1}{3}$ per cent of its time deposits. The board is empowered to name, from time to time, other cities besides central reserve cities in which such loans may not be made.

By entering into the trust, savings, and real estate loan business the commercial banks tended to reduce the liquidity of their assets; compensation for this, however, is realized in the higher liquidity of their other assets through rediscounts with and loans from the federal reserve banks.

The national banks were given power to accept bills drawn upon them under certain conditions, to establish foreign branches,

and to do other things denied them heretofore. But since such powers were not much used by state banks, if they had them, the legislation was not occasioned by a desire to equalize the conditions of competition.

CHAPTER XIV

FEDERAL RESERVE BANKS

Capitalization of Federal Reserve Banks

The Federal Reserve Act prescribes a minimum capitalization of \$4,000,000, divided into \$100 shares for each of the twelve federal reserve banks. The outstanding capital stock increases or decreases from time to time with the increase or decrease in the capital or surplus of member banks. When a new bank joins the system it is required to subscribe 6 per cent of its capital and surplus to the stock of the federal reserve bank, and when a bank already a member increases its capitalization or surplus it must at the same time increase its subscription so as to reach 6 per cent of the new amount. Half this original subscription is payable in three quarterly instalments, and the rest at the call of the Federal Reserve Board. If a bank buys reserve bank stock it contracts to pay par value plus $\frac{1}{2}$ per cent a month for each month since the last dividend payment. When a bank reduces its capital and surplus or withdraws from the system, refunds are made to it on the same basis. The shares may not be transferred nor hypothecated.

To date, the Federal Reserve Board has not called for any part of the second half of the stock subscriptions of member banks. The accumulation of a goodly surplus in recent years makes it improbable that the uncalled subscription will ever be called. It will simply remain as a contingent asset of the reserve bank.

The advisability of capitalizing the reserve banks, or at least requiring the members to pay subscriptions to their stock, has been questioned. The objection arose because of the low earnings of certain reserve banks during the period 1914-1917. The ar-

guments were that the requirement of a 6 per cent subscription, as explained above, was arbitrary and no more than a guess at what the capital requirements of the reserve banks would be, and that the mere liability of the member banks for the required capital would have been as effective as its payment; that the paid-in capital of the reserve banks created a dividend responsibility which forced them to undertake banking operations in the open market in competition with the member owners; that the gold reserves paid into the reserve banks were ample to take care of the rediscounting needs of the member banks; and that the subscription requirements for member banks discouraged state banks from entering the system.

The capitalization of the reserve banks, however, serves many useful ends: It provides an initial working capital; it gives the member banks a decided interest in the operation of the reserve bank other than if the institution were a mere depository; it provides resources sufficient to insure to the reserve bank stability and continuity; it furthers open-market operations, through which the board and reserve banks can control the banking situation; and it is a fair investment for the members.

Surplus

The act provides for an annual 6 per cent cumulative dividend on the paid-in capital stock of the reserve bank. Any excess of net earnings above the 6 per cent accrues to the United States as a franchise tax, except that the whole of such net earnings shall be paid into a surplus fund until it shall amount to 100 per cent of the subscribed capital stock, and thereafter 10 per cent of the net earnings shall be paid into surplus. The earnings derived by the United States from this source are, at the discretion of the Secretary of the Treasury, put into the gold reserve fund for the redemption of the greenbacks or used to reduce the government debt.

If a federal reserve bank should be dissolved or go into liquidation, any surplus remaining after the payment of its debts,

dividend requirements, and the par value of the outstanding stock, would be paid to and become the property of the United States. In other words, any surplus accrued is a contingent asset of the United States government rather than of the member banks.

The Federal Reserve Act differs from the charters of most foreign central banks in that it names no specific annual franchise tax, but provides first for the payment of dividends to the stockholding banks at a moderate rate of return, leaving the excess of earnings, whatever that may be, for the government.

With the exception of real estate owned, the federal reserve banks, their capital and surplus, and the income derived therefrom, are exempt from the burden of federal, state, and local taxation.

Earnings and Operating Costs

During their first years of operation not many of the reserve banks were able to earn the 6 per cent. The amortization of organization expenses, the small volume of business, and the low earnings on their investments, made it impossible to pay full dividends. But by the year 1918 every bank had met its arrears, or nearly so, and some had turned over excess profits to the government. The low earnings at first occasioned demands for the reduction or abolition of the capitalization, for the reduction in number of these expensive institutions, and for the suspension of further subscription payments. These demands have ceased since all the banks are now earning more than 6 per cent, have paid their arrears of dividends, and are accumulating surpluses.

By the end of 1920 all but three of the federal reserve banks had accumulated surpluses in excess of their capital stock, and for that calendar year the ratio of current net earnings to average paid-in capital and reserve balance combined ranged from 5.6 per cent (the Dallas bank) to 11 per cent (the Atlanta bank) and averaged 7.9 per cent.

TABLE SHOWING THE DISTRIBUTION OF EARNINGS OF THE FEDERAL RESERVE BANKS FOR THE YEAR ENDING DECEMBER 31, 1919

(In millions, except "Dividend Payments," which are in thousands)

Federal	Gross Earnings	Net Earnings	Dividend Payments	Transferred to Surplus	Franchise Tax to U. S.	Subscribed Capital	Surplus	Ratio of Surplus to Capital
Boston	\$ 7.4	\$ 5.8	\$ 414.4	\$ 5.4	\$ 14.2	\$ 8.4	58.80%
New York	35.3	27.9	1,291.0	23.9	\$2.7	44.8	45.0	100.67
Philadelphia	8.6	6.7	462.3	6.2	15.8	8.8	55.84
Cleveland	7.8	6.0	556.7	5.5	19.1	9.0	47.67
Richmond	4.8	3.9	252.9	3.6	8.8	5.8	66.26
Atlanta	4.4	3.4	197.4	3.2	6.9	4.7	68.48
Chicago	12.0	8.6	700.8	7.9	24.7	14.3	57.87
St. Louis	3.9	2.4	234.6	2.1	8.1	3.7	45.81
Minneapolis	3.0	2.3	180.2	2.1	6.1	3.6	58.05
Kansas City	4.9	3.9	228.7	3.7	8.0	6.1	76.15
Dallas	3.0	2.0	196.3	1.8	6.8	3.0	44.29
San Francisco	7.0	5.3	296.2	5.1	11.5	7.5	65.56
	\$102.4	\$78.4	\$5,011.8	\$70.6	\$2.7	\$174.8	\$120.1	66.71%

The combined gross earnings of the twelve federal reserve banks for the calendar year 1917 were \$12.1 million; for 1918, \$20.3 million; and for 1919, \$102.4 million. This growth of earnings is quite remarkable. It was largely occasioned by the increased use made of the reserve banks by members borrowing or rediscounting at the favorable rates maintained by the reserve banks. This policy of low rates was part of the general policy of war finance. In 1919, of the total earnings, 78.9 per cent came from discounts, largely war paper, 13.7 per cent from bills purchased in open market, and 5.6 per cent from United States securities owned.

These high earnings have had several important effects, some of which strike at the root of the problem of central banking. One effect has been to raise a demand that the reserve banks pay

interest on reserve balances. Another demand is that member banks should be permitted to share in the profits of the reserve banks. Thirdly, high earnings have made it possible for the reserve banks to undertake various services for the members and thus to share the profits with them indirectly. Such indirect sharing of profits is illustrated by the absorption of the service charges in the collection of checks, the absorption of the express charges on currency shipments, etc. A fourth effect has been to question the policy of permitting these central banks to make profits without limit. Undoubtedly a central bank should not be run for profits, since it has a greater public responsibility than the other banks, and this fact should take precedence over all other factors in determining its policies. The present situation is peculiar, for the war finance policy demanded low rediscount rates, and these rates made high earnings of the reserve banks inevitable.

The operating costs of the federal reserve banks for the year 1919 were \$20.3 million. They are expensive institutions. Undoubtedly their number might be reduced and the nation's business be handled as expeditiously as at present. Not only is the expense of their operation large, but this expense is further increased by certain legal provisions which among other things place upon the reserve banks the expenses of the Federal Reserve Board, amounting in 1919 to \$595,000; but all this is simply the price paid for the benefits of the regional system.

The Board of Directors

Each reserve bank is supervised and controlled by a board of directors of nine members, holding office three years and divided into classes A, B, and C, of three members each. The directors owe their appointment to different agencies, and represent very comprehensively the business interests of the country. Class A members are chosen by and represent the stockholding banks; class B members at the time of their election must be actively engaged in their district in commerce, agriculture, or some other

industrial pursuit; and class C members are designated by the Federal Reserve Board.

No member of Congress may be a director of a federal reserve bank. No class B director may be an officer, director, or employee of any other bank. No class C director may be an officer, director, employee, or stockholder of any other bank. These provisions against interlocking directorates were designed to insure impartiality and to prevent the control of the policy of a reserve bank from falling into the hands of persons with adverse interests.

Election of Directors

Directors of class A and class B are chosen as follows: The banks of the district are classified by the chairman of the board of directors into three groups, each containing about one-third of the banks and consisting of banks of similar capitalization. Each group elects one A and one B director every third year. If vacancies occur they are filled in the same manner as the original election, and such appointees hold office for the unexpired term. The board of directors of each member bank elects a district reserve elector and certifies his name to the chairman of the reserve bank board, who prepares lists of the electors thus named in each group and sends one list to each elector in the group. Each member bank may nominate to the chairman one candidate for class A and another for class B, and a copy of the list of these nominees is sent to each elector. The electors vote by preferential ballot.

The method of election has been criticized, first, because of its awkwardness and the fact that few member banks are sufficiently interested to participate in the election, and, secondly, because the "one bank, one vote" equality provided by the act gives the preponderating power to the smaller banks. But this last objection is probably more than counterbalanced by avoidance of the opposite criticism that would arise if the larger banks were given

plural voting, namely, that the system was run by and in the interests of the larger institutions.

Directors of class C at the time of their appointment shall have been for at least two years residents in the district for which they are appointed. One of them is designated by the Federal Reserve Board as "Chairman of the Board of Directors of the Federal Reserve Bank" and as "Federal Reserve Agent." Another class C director is designated as "Deputy Chairman," to exercise the powers of the chairman when necessary. In case of absence of both the chairman and deputy chairman, the third class C director presides at meetings of the board.

The Federal Reserve Agent

The federal reserve agent must be a man of tested banking experience. As indicated by his other title mentioned above, he acts as chairman of the board of directors of the reserve bank and maintains the office of the board on the premises of the reserve bank. He makes regular reports to the Federal Reserve Board, and acts as its official representative for the performance of its functions. His compensation is fixed by the Federal Reserve Board but paid by the reserve bank. Subject to the approval of the Federal Reserve Board he may appoint assistants, who must likewise be persons of tested banking experience, and who assist him and act in his name and stead during his absence or disability. The assistants are put under such bonds as the Federal Reserve Board may deem necessary for the protection of the United States, and receive a compensation fixed by the Federal Reserve Board but paid by the reserve bank. The minimum bonds fixed by the Federal Reserve Board are \$100,000 for the federal reserve agents and \$50,000 for the assistant federal reserve agents, but the board of directors of the reserve bank may require higher bonds if they deem it desirable.

One of the most important duties of a federal reserve agent is to issue federal reserve notes to the reserve banks, holding gold and

commercial paper against the issue of such notes and handling a portion of the gold settlement fund. These moneys, of course, reach into millions. The duties of the official may be described by enumerating the four departments among which the federal reserve agent of the New York bank has divided his functions, as follows:

1. The member bank relations department, which seeks to promote better relations between the reserve bank and the member bank, and handles the state bank membership affairs.
2. The note issues department, which issues the federal reserve notes to the reserve bank, and cares for the collateral to secure these notes, and has the custody of the commercial paper of other federal reserve banks and federal reserve agents.
3. The bank examinations department, which examines the member banks and has custody of the examination reports, handles applications for membership, for capital stock, for permission to accept bills drawn upon it up to 100 per cent of its capital stock and surplus, and for permission to do fiduciary business, and which is also on the lookout for violations of the Clayton Act by the banks.
4. The statistics department, which reports to the Federal Reserve Board on the business and banking conditions of the district, and prepares statistical information.

Internal Organization

In 1915 and again in 1918, the Federal Reserve Board suggested a scheme of internal organization for the federal reserve banks. The 1918 scheme is shown in Figure 5.

Reorganization of Federal Reserve Bank of New York 1919

The heavy demands made by the war upon the services of the federal reserve banks led to a disproportionate growth of certain

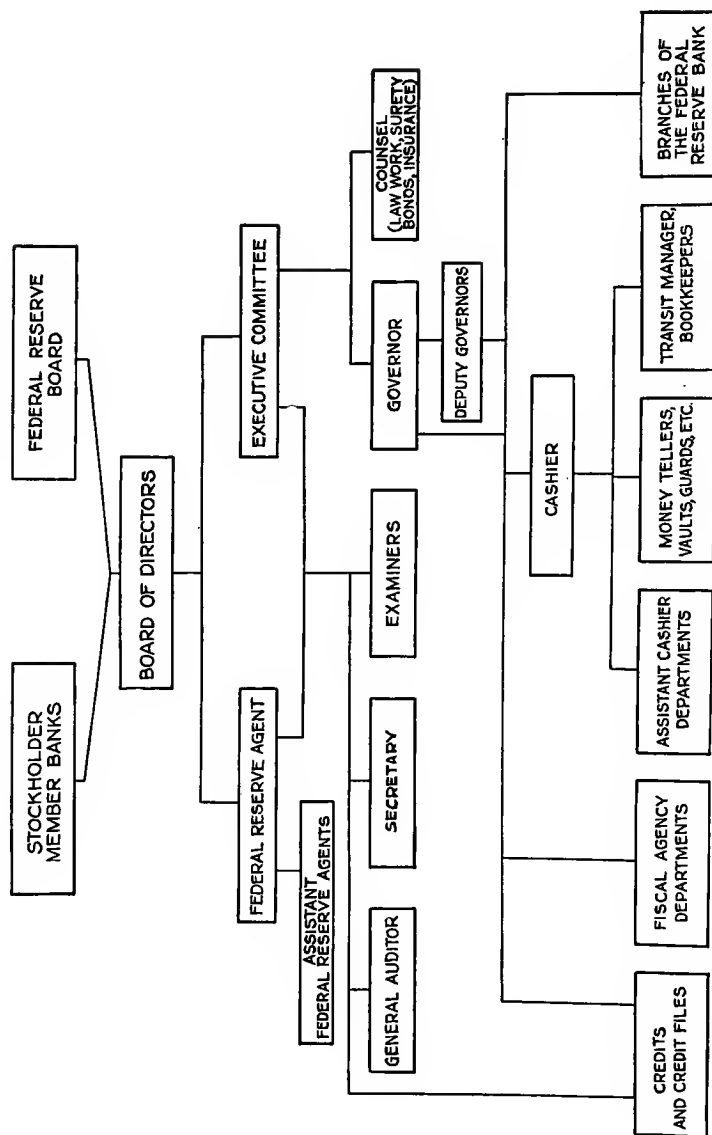

Figure 5. Proposed Type of Organization for the Federal Reserve Banks, 1918

functions and departments, while the general growth of these banks since 1914 had been so great as to require a complete reorganization. The Federal Reserve Bank of New York devised a scheme of organization which it believed would facilitate the work of that bank and this reorganization (see Figure 6) was put into operation in September, 1919. It has as its aim the separation of the functions of operation and organization, and it places the responsibility for conducting each department upon its own administrative officer, requiring him to transact completely the business falling within his province. As every activity is definitely allocated to a specific department, responsibility is thus more specifically fixed. One of the most striking features of the change is the abolition of the office of cashier, through whose hands in the old organization all operating matters, in the last analysis, had to pass.

The officers of the New York bank are grouped as follows:

1. The junior officers are the managers of the various departments, their position corresponding to the former position of assistant cashier. Each of these managers is responsible for the duties of operation or organization, as the case may be, of his department. He has working under him subordinates authorized to sign within specified limitations, as well as a sufficient staff to complete all the business of his department.

2. The senior officers are called "controllers." To each controller is assigned the supervision of one or more of the important functions of the bank, and each is responsible for the development of the policies relating thereto and for supervision of the departments charged with carrying out such functions. The controllers are not in charge of the operation of the departments, but supervise and control their policies; however, with the present size of the bank, a controller may act as a department manager, and a deputy governor as controller.

3. The general officers include the governor, the deputy governors, and the chairman of the board of directors, corre-

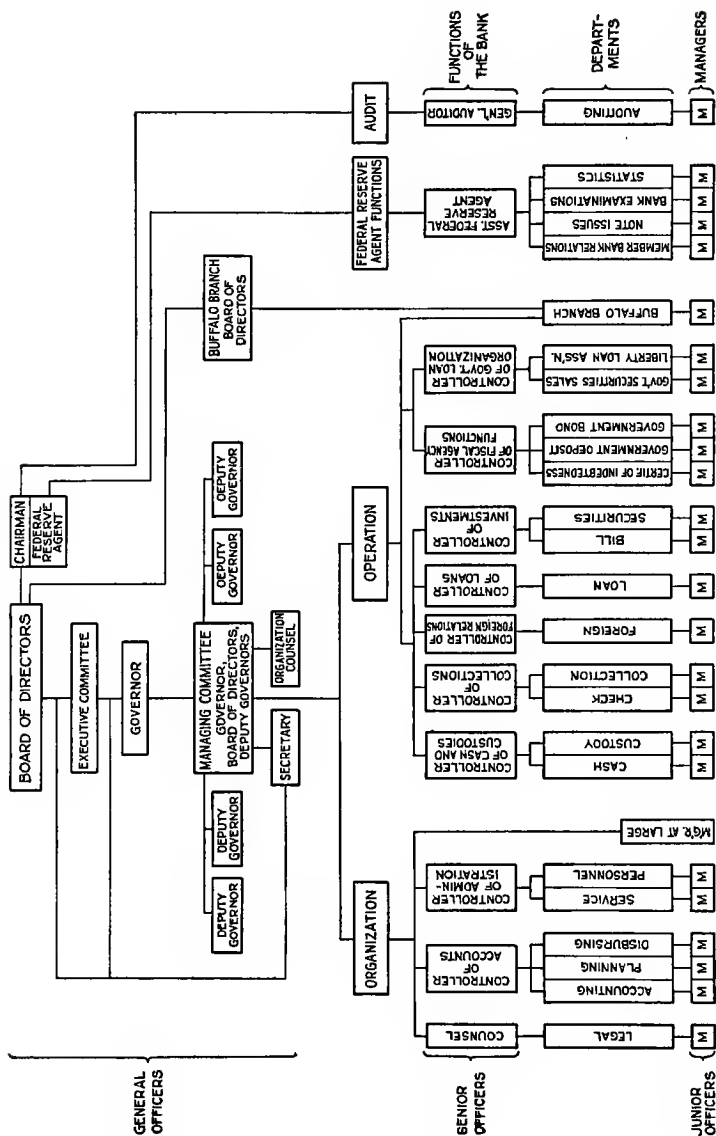

Figure 6. Official Organization of the Federal Reserve Banks of New York

sponding to the president, vice-presidents, and chairman of the board of directors of other banks. These general officers form the managing committee of the bank, and certain controllers from time to time are invited to confer with this committee at its daily meetings. The members of the committee are concerned with general policies of administration and not with specific functions or departments of the bank.

Another aim of reorganization was to center responsibility upon the junior and senior officers, thus affording them more opportunities for promotion than existed under the old form of organization with its one cashiership to which office all assistant cashiers aspired. The plan of fixing responsibility has been extended to the divisions of the departments, each of which is put in charge of a chief, and many of the larger divisions are divided into sections, each in charge of a supervisor.

As this functional system of management seems to be successful, it will probably be adopted by the other federal reserve banks.

The Governor

The two chief men in a federal reserve bank are the federal reserve agent, whose duties have been stated in a preceding section, and the governor. The governor is the active operating officer of the bank. He supervises, through his subordinates, the details of operation, controls the personnel, devises internal organization, and executes the instructions of the board of directors by whom he is elected. Although he is hired on a commercial basis, the responsibilities of his position make him a public servant. The federal reserve agent is a government appointee and his salary is not so likely to represent his commercial worth. The question of the relative importance and honor of the two positions has been much discussed. They are approximately co-ordinate in rank, and their duties do not overlap or conflict.

On December 31, 1919, the employees of the twelve federal reserve banks numbered 9,393, of which New York had 2,896, and

Chicago, 1,199. The smallest force was that of Minneapolis, which had 287. The average salaries of officers ranged from \$5,080 at Atlanta, to \$10,540 at New York; and the average salary of employees ranged from \$1,031 at Richmond, to \$1,255 at San Francisco.

Powers of the Reserve Banks

The federal reserve banks are primarily bankers' banks, for their customers and owners are the member banks. But they are clothed with powers enabling them also to perform certain services for non-member banks and trust companies, and to operate in the open market in certain ways. They also serve the government in a fiscal capacity. Their wide powers are expected to invest them with a high sense of their responsibilities for the public welfare.

Among the chief powers of a federal reserve bank are those enumerated below:

1. To receive from its members or from the United States government deposits of cash and cash items, and, for collection, maturing notes and bills.
2. To receive from other federal reserve banks, solely for purposes of exchange or collection, deposits of cash, cash items, and maturing notes and bills payable within its district.
3. To receive from any non-member bank or trust company, solely for the purposes of exchange or collection, deposits of cash and cash items and maturing bills and notes, provided the non-member maintains with the reserve bank a balance sufficient to offset the items in transit held for its account by the reserve bank.
4. To discount, upon indorsement of any of its members, commercial paper eligible under the rules and definitions of the Federal Reserve Board and under the terms of the act.

5. To make advances to its members on their promissory notes, for periods not exceeding 15 days, at rates fixed by the bank, subject to review and determination by the board, provided such notes are secured by paper eligible for discount or by United States securities.
6. To issue federal reserve notes.
7. To establish branches, agencies, or correspondents.
8. To perform the following open-market operations: to deal in gold at home or abroad, to make loans thereon, to exchange federal reserve notes for gold or gold certificates, and to contract for loans of gold.
9. To buy and sell at home or abroad, securities of the United States, and bills, notes, revenue bonds, and warrants with maturity from date of purchase not exceeding six months, issued in anticipation of the payment of taxes by the individual states or political divisions or municipalities of the United States.
10. To purchase from members and sell, with or without its indorsement, bills of exchange arising out of commercial transactions.
11. To establish from time to time rates of discount to be charged by it for each class of paper, subject to review and determination by the Federal Reserve Board.
12. To establish for exchange purposes accounts with other federal reserve banks and agencies, correspondents, branches, and accounts in foreign countries; to buy and sell through these agencies commercial paper; and to open and maintain accounts for such agencies or correspondents.

Typical Bank Departments

These and other functions are distributed among the departments of the Federal Reserve Bank of New York (using this bank for illustration) as follows:

The Cash Department

1. The Authorities Division handles signatures, stop-payments, examination of checks, discount resolutions, and extracts from by-laws and resolutions of customers.
2. The Paying Division (Paying Teller) handles the payment of checks and orders, the settlement of clearing house balances, and certifications.
3. The Shipping Division handles the shipment of funds from the bank by registered mail or express.
4. The Codes and Tests Division prepares and keeps codes and makes tests for telegraph and cable uses.
5. The Wire Transfer Division attends to the transfer of funds by cable and telegraph, as well as letters of advice, and officers' checks.
6. The Incoming Mail Division receives and credits the cash letters.
7. The Receiving Division (Receiving Teller) receives the cash deposits over the counter and the currency shipments by express and registered mail.
8. The Money Division sorts and counts the money received from all sources, and has the mutilated money redeemed.
9. The Coin and Bullion Division handles the coin and bullion.
10. To another Division are allocated the applications for federal reserve notes, the redemption accounts for federal reserve notes and federal reserve bank notes, the account of the bank with the United States government, the gold settlement fund, and the care and determination of the reserve position.

The Custody Department

1. The Custody Division has the custody of the collateral for all departments, including the investments of the federal reserve bank itself, the collateral on discounts and advances, collateral for government deposits, items for safe-keeping, fiscal agency collateral, and the clipping of coupons as they appear.
2. The Vault Division has the general care and management of the vaults; it watches their opening and closing and the combinations.

The Check Department

1. The Incoming Mail Division handles the general distribution of the mail, prepares the morning exchanges for the clearing house, receives and credits remittances, advising immediate credits and proving deferred credits.

2. The Transit Division remits checks by mail for payment, and advises deferred debits and deferred credits.
3. The Redemption and Return Items Division examines and returns unpaid cash items, attends to the afternoon clearing house exchanges, and handles redemptions.
4. The Adjustment Division handles lost items, traces errors, and makes adjustments.

The Collections Department

1. The Government Check Division receives the Government checks out of the exchanges from the clearing houses, sorts and schedules them, and attends to the accounting for them.
2. The City Collection Division makes collections by messenger, or through the clearing house.
3. The Country Collections Division handles maturing rediscounts, up-town city collection items, and country collection items.
4. The Coupon Collections Division collects coupons and matured bonds.

The Loan Department

1. The Credit Division receives applications for advances and discounts, handles the commercial statements of borrowers, and makes credit investigations.
2. The Loans and Discounts Division handles advances and rediscounts made to member banks and other federal reserve banks, and the collateral to secure these, keeping records, schedules, ticklers, and making necessary statements and reports.

The Foreign Department

The Foreign Department handles the accounts of foreign governments and banks, the allotments and purchases of foreign exchange for other federal reserve banks, and all government regulations of foreign exchange operations.

The Certificate of Indebtedness Department

The Certificate of Indebtedness Department handles the subscriptions, the deliveries, and the redemptions of the certificates of indebtedness of the United States Treasury, and also the account of the War Finance Corporation.

The Government Deposit Department

The Government Deposit Department handles the applications of the banks for government deposits, the receipt and delivery of securities for collateral, the calculation and receipt of interest on

the deposits, the records of redeposits and withdrawals, and the records of collateral and of coupons from the collateral.

The Government Bond Department

1. The Bond Division handles the incoming and outgoing mails that pertain to government bonds, the loans records, and records of individual subscriptions; the conversion, registration, exchange, transfer, and preparation of the bonds; the work in connection with the war savings stamps and thrift stamps; and all incidental work.
2. The Coupon Paying Division pays due coupons from the United States government securities, the British government securities, the federal farm loan bonds, and the issues of the War Finance Corporation.

The Government Securities Sales Department

The Government Securities Sales Department includes a number of divisions, the name of each indicating its function in the sale of securities:

1. Certificates of Indebtedness Sales
2. War Savings Societies
3. School
4. Advertising
5. Women's
6. Labor
7. Press
8. Foreign Language
9. New York State
10. New York City
11. New Jersey
12. Office Service

The Liberty Loan Association Department

The Liberty Loan Association Department includes five divisions which perform the various operations connected with the Liberty and Victory Loan issues:

1. Consignment
2. Financial
3. Liquidation
4. Subscribers' Service
5. Office Service

The Bill Department

The Bill Department performs the open-market operations concerned with bills of exchange, keeps records of bills purchased for the reserve bank itself and for others, makes allotments to and purchases for the other federal reserve banks and for other correspondents, and makes and keeps the purchase and the sales contracts.

The Securities Department

The Securities Department handles the open-market transactions in United States securities and municipal warrants, makes and keeps the purchase and sale contracts, keeps records of the securities owned and of those held for safe-keeping, the purchases and sales and allotments of United States bonds covering the national bank notes and federal reserve bank notes, and the purchase and sale of securities of member banks and for other federal reserve banks.

Resources and Liabilities of the Federal Reserve Banks

In the following statement, as of July 17, 1920, the resources and liabilities of the twelve federal reserve banks are grouped and numbered for convenience in describing them.

CONSOLIDATED STATEMENT OF THE
FEDERAL RESERVE BANKS

	<i>Resources</i>	<i>Millions</i>
Reserves		
1. Gold Coin and Certificates.....	\$ 168	
2. Gold Settlement Fund, with the Federal Reserve Board. .	393	
3. Gold with Foreign Agencies.....	111	
Total Gold Held by the Banks.....	\$ 674	
4. Gold with the Federal Reserve Agents.....	1,152	
5. Gold Redemption Fund Against the Federal Reserve Notes.....	144	
Total Gold Reserves.....	\$ 1,971	
6. Legal Tenders, Silver, etc.....	\$ 2,119	

Earning Assets

7. Bills Discounted: Secured by Government War Obligations	\$1,255
8. All Other Bills Discounted	1,234
9. Bills Bought in the Open Market	356
Total Bills on Hand	<u>\$2,846</u>
10. United States Government Bonds and Certificates of Indebtedness	321
Total Earning Assets	<u>\$3,167</u>

Miscellaneous Items

11. Bank Premises	14
12. Uncollected Items and Other Deductions from Gross Deposits	890
13. Redemption Fund against Federal Reserve Bank Notes	12
14. All Other Resources	4
Total Resources	<u><u>\$6,208</u></u>

Liabilities

Capital

15. Capital Paid in	\$ 94
16. Surplus	164
Total Capital Liabilities	<u>\$ 259</u>

Deposits

17. Government Deposits	11
18. Due to Member Banks—Reserve Account	1,867
19. Deferred Availability Items	647
20. Other Deposits Included for Government Credits	50
Total Gross Deposits	<u>\$2,577</u>

Notes

21. Federal Reserve Notes in Actual Circulation	\$3,135
22. Federal Reserve Bank Notes in Circulation, Net Liability	189
Total Note Liabilities	<u>\$3,325</u>
23. All Other Liabilities	45
Total Liabilities	<u><u>\$6,208</u></u>

In the scrutiny of the above statement it will be noted that the reserves of the federal reserve banks are held in different places: the gold coin, gold certificates, legal tenders, silver, etc. (items 1 and 6), are the till money held in their own vaults; the gold settlement fund (item 2) is held in Washington, D. C.; other gold (item 3) is held by agencies abroad, such as the Bank of England and others; other gold (item 4) is held by the federal reserve agents, as security against the federal reserve notes and for other purposes; and the redemption funds (items 5 and 13) are also held at Washington, the one against the federal reserve notes being lawful reserve, but not the one against the federal reserve bank notes. This allocation of parts of the reserve to different places and uses does not mean that it is any less a reserve, but rather that it is a more efficient reserve, for it is placed where payments are most conveniently and frequently made.

The earning assets of the reserve banks consist of short-term bills and long-term investments. The bills are of two types: those secured by government war obligations (item 7) and commonly called "war paper" and those of a direct commercial origin (items 8 and 9). The bills are discounted for the member banks and are called "rediscounts" (item 8), or else they are bought in the open market (item 9). The United States securities (item 10) are those bought by the banks for investment purposes, or purchased in the process of retiring the national bank notes or in the process of issuing federal reserve bank notes under the Pittman Act, or acquired in the process of collecting debts, etc. The methods and occasions of acquiring these various earning assets are described in later chapters.

The investments of a federal reserve bank are purchased from member banks or in the open market here and abroad. Practically all are voluntary purchases for the purpose of earnings. The bank, however, may be compelled by the Federal Reserve Board to purchase 2 per cent bonds, as well as commercial paper, from its member banks. The nature of these investments is strictly

defined by law and regulated by the board. Their essential feature is that they be highly liquid.

The assets of the central bank in any system should be cash or highly liquid investments, its earning assets should constitute but a small fraction of its resources, and the rest of its assets should be in current funds held against emergencies. Such a bank is then able to absorb commercial paper in a redundant market, and to release it in an undersupplied market; or, in other terms, the bank can loan out funds in a tight money market and contract them in an easier market. By such open-market operations the reserve banks will, when the system is developed, control the money market.

Such operations by the federal reserve banks make the market rate conform to the rediscount rate set by themselves and the board. By becoming an active factor in the market, buying and selling at the established rates, the banks can make their rediscount rate effective; otherwise, whether it would be effective or not would depend wholly upon the extent to which members chose to rediscount. By this means the reserve banks are also able to maintain a reasonable and stable discount rate. A power of control, however, is possible only if the reserve banks have a substantial amount of loan funds at their disposal, if the open-market purchases are commercial paper, and if really a broad discount market exists. The Federal Reserve Act was so drawn as to eliminate from the transactions of the reserve banks call loans (see Chapter XXI) on stock exchange collateral, because experience had shown that in panics such loans could not be realized except by selling at a sacrifice the collateral on which they were based. For this reason during the war it was found necessary to supplement the control by the reserve banks with a voluntary "Money Committee" in New York, which so pooled the fund available for call loans as to control the call loan rate.

To continue the discussion of the items shown in the statement on pages 275 and 276 all the federal reserve banks are now provided

with suitable building sites (item 11) and plans are under way for the erection of buildings. It is obviously desirable for these banks to have permanent and commodious quarters, alike for the efficiency of their service and for their prestige.

The federal reserve banks act as clearing houses for the banks of their respective districts, and, through the gold settlement fund, for the banks of the whole country. The operation of this fund as part of the federal par collection system will be described later. The reserve banks accept the items for collection and defer the availability of the proceeds until sufficient time has elapsed for collection to be made. At any one time, therefore, the uncollected items (item 12) on hand are a resource and the deferred availability (item 19) is a liability.

Liabilities of the Federal Reserve Banks

The paid-in capital of the reserve banks (item 15) amounts to 3 per cent of the capital and surplus of the member banks. The surplus of the reserve banks (item 16) now exceeds their capital and this item will continue to increase, for 10 per cent of the net earnings are converted to surplus after the surplus of a reserve bank reaches 100 per cent of its capital. The other 3 per cent of the capital subscription remains as a contingent asset of the bank.

The deposits of the reserve banks are liabilities to the government (item 17) and to the member banks for reserve account (item 18), and to the banks which have sent collection items whose availability has been deferred (item 19). The reserve of a member bank consists of the deposit rights against the federal reserve bank. The balance of a member bank with its reserve bank is divided into "account current" and "reserve account," and transfers from one account to the other can be made at the member's instance.

The note liabilities are of two classes: the federal reserve notes (item 21) and the federal reserve bank notes (item 22). The nature of these items is discussed in the following chapter.

Fiscal Agents of the United States

The Federal Reserve Act provides that moneys held in the general fund of the United States Treasury, except the 5 per cent redemption funds against national bank notes and federal reserve notes, may, upon the direction of the Secretary of the Treasury, be deposited in federal reserve banks, which banks, when required by the Secretary, shall act as fiscal agents of the United States. The revenues of the government in whole or part may be so deposited and disbursements made by checks drawn against such deposits.

On January 1, 1916, the Secretary began to use the reserve banks as depositories. He commenced by transferring part of the government deposits from banks in federal reserve cities to the reserve banks. Not until the United States began the sale of treasury certificates of indebtedness and Liberty Loan bonds, however, did this item become important or considerable. In announcing the first Liberty Loan in April, 1917, the Secretary also announced that each federal reserve bank would be constituted a central agency in its district for the organization of a bond campaign, for receiving subscriptions and payments, making deliveries, and managing the necessary details. Through these duties the reserve banks were brought into intimate contact with the Treasury and with the member banks of their districts, and together they proved invaluable agents of the Treasury in war financing.

The duties of a fiscal agent are numerous. They include the handling of all details connected with the sales, subscriptions, allotments, redemptions, conversions, and distribution of government loans and certificates of indebtedness; the collection of all bond and certificate payments, and the redeposit of these funds with designated depositories, whence they are withdrawn upon request of the Treasury; the payment of due coupons; the operations connected with the treasury savings certificates, the war savings stamps, and the thrift stamps. The expense of the fiscal

agency function is kept separate from the other expenses of the reserve bank and is reimbursed from the Treasury.

The average government daily balance with the depositories during 1919 was \$738 million; the number of depositories designated by the Treasury through the federal reserve banks was 7,632 on December 31, 1919; as security for these deposits, the federal reserve banks received and cared for the collateral of \$1,338 million. During the year the reserve banks handled 33 million government checks, amounting to \$14.5 billion. The government balance in the federal reserve banks averaged \$99 million, though it fluctuated widely because of the constantly changing requirements of the Treasury and the seasonal character of the collections of the internal revenues. By means of inter-district settlements through the gold settlement fund, the Treasury is able to leave the funds with the designated depository banks throughout the country until actually required, transfer being made by telegraph to federal reserve banks in cities where government disbursements are made.

The Treasury and Reserve Banks

The number of depositories was greatly increased during the war, and many "special depositories" will continue to be used until the war financing definitely ends. Meanwhile the Treasury, despite political pressure, is reducing the number of regular depositories and the deposits carried with many other banks; it is attempting a "scientific apportionment" by cutting off the inactive accounts and reducing balances so that each bank will be able to realize equal returns on the basis of the business done for the government. This is a logical step, for with the establishment of the federal reserve banks and their use as fiscal agents, there is less need for depositories; besides, it is now an economy to use the government money to reduce the debt, for the 2 per cent interest on deposits does not now give sufficient compensation for the rate paid by the government on its loans.

Our Independent Treasury has been a source of great financial weakness and disturbance. Want of a sensible budget system has resulted in a series of surpluses and deficits in the Treasury, causing alterations of tight and easy money in the market. The surpluses occurred at times of great importation, that is, of business boom, and, by reducing bank reserves at the time of big demand for loans, accentuated the rise of money rates. The government had no good means of making such balances available for banking uses, nor had it any efficient agency under its control and in direct intimate contact with the banks of the country, through which it could float loans. The federal reserve banks have provided for both. The sub-treasuries exercised some banking functions, such as the transfer of money by telegraph, the clearance of checks through the clearing house, and the receipt of taxes by certified checks, but most of their transactions were in currency and were slow and limited because they had no banking connections. If the government wished to redeposit the accrued surpluses, it was practically impossible to redeposit them in the banks from which they were originally withdrawn. Too often politics, caprice, or favoritism determined their distribution. Besides they were deposited in too many banks too widely separated. The twelve federal reserve banks which now act as fiscal agents for the government can supply the same facilities as a thousand or more national banks formerly supplied, thus simplifying the handling of the government funds. Another defect of the former system was, that the depositories had to pledge United States securities for government deposits, thus tying up such a quantity of bonds that the national bank note issue could not be increased in emergencies.

One of the leading criticisms against the maintenance of Independent Treasury was the discretionary power lodged with the Secretary in his choice and use of banks as depositories—a power fraught with danger as well as with good; for capricious action on his part might make or break a bank and might disturb the fi-

nancial equilibrium of the country. Much depended upon the Secretary, his will, good sense, and skill. The same criticism applies to the existing federal reserve system, for the Secretary may or may not use the federal reserve banks as depositories for all or part of the government funds.

Duties of Former Sub-Treasuries

The functions of the sub-treasuries were in part as follows:

1. Issue of gold order certificates on gold deposits.
2. Acceptance of gold coins and silver dollars for exchange.
3. Acceptance of fractional silver, greenbacks, minor coins, gold certificates and silver certificates for redemption.
4. Cancellation and laundering of unfit currency.
5. Exchange of various kinds of money for other kinds requested.
6. Remittance from United States depository banks of their surplus deposits of internal revenue, customs, money order, postal, and similar funds.
7. Receipt of deposits of postal savings funds direct.
8. Receipt of deposits of money order funds direct and indirect.
9. Receipt of deposits on account of the 5 per cent redemption fund.
10. Receipt of deposits of interest on public deposits.
11. Receipt of deposits of funds belonging to disbursing officers.
12. Receipt of funds deposited for transfer to some other point through a payment by a sub-treasury located there.
13. Encashment of checks, warrants, and drafts drawn against the Treasurer of the United States and presented at the sub-treasury for payment.
14. Payment of the United States coupons and interest checks.
15. Custody of large reserve and trust funds.

Efforts have been made during recent years to abolish the sub-treasuries and have their work done by the federal reserve banks. These efforts reached success on May 29, 1920, when Congress authorized and directed the Secretary of the Treasury to discontinue the sub-treasuries by July 1, 1921.

The sub-treasuries were located in New York, Boston, Philadelphia, Baltimore, San Francisco, New Orleans, St. Louis, Chicago, and Cincinnati. In each of these cities there is now either a federal reserve bank or one of its branches. The argument favoring the abolition of the sub-treasuries was the apparent duplication of systems and its unnecessary expense. Against this argument it was contended that little economy would result from the merging of the two sets of institutions; that the trust funds against the gold and silver certificates and the greenbacks should not be committed to the custody of private corporations; and that the services required by the government would be less well rendered under the change of system.

The recent law provides that the Secretary of the Treasury may assign such of the duties performed by the sub-treasuries to the Treasurer of the United States, to the mint, and to the assay offices, as he may deem best; that he may utilize the federal reserve banks as depositories or fiscal agents of the United States; that all trust or special funds must be kept separate and distinct from the other assets of the federal reserve bank and be held in joint custody of the federal reserve agent and the federal reserve bank; and that the Secretary may assign any rooms, vaults, equipment, safes, or space in buildings used by the sub-treasuries to any federal reserve bank acting as fiscal agent for the government.

Between the dates October 25, 1920, and February 10, 1921, the closing of the sub-treasuries and the transfer of their duties were accomplished without interruption to business and without interference with the financial operations of the government. In some cities the former sub-treasury buildings continue to be used, in others the transactions are conducted in the reserve bank buildings.

CHAPTER XV

THE FEDERAL RESERVE BOARD

Membership of the Board

Our previous experience with a central national bank, in 1791-1811 and again in 1816-1836, had shown that such an institution, despite its financial success, was likely to fall a victim of politics, as jealousy of the money power is too prevalent and too effective a vote-winner to be neglected by demagogic politicians. Therefore in setting up the present federal reserve system Congress showed political astuteness by establishing it along regional lines, giving it a degree of local autonomy and placing it close to the people, and by naming the centralized institution "board" instead of "bank." It is with this board that supreme control of the system is lodged.

The board is composed of seven members, consisting of the Secretary of the Treasury and the Comptroller of the Currency, who are members *ex officio*, and five additional members who are appointed by the President with the advice and consent of the Senate. These additional members must be chosen with due regard to a fair representation of the different commercial, industrial, and geographical divisions of the country, not more than one coming from the same reserve district. The five members must give their entire time to the services of the board and each receives an annual salary of \$12,000; the Comptroller in addition to his regular salary receives \$7,000 for his services on the board. In order to eliminate favoritism to banks, no members of the board are eligible, during the time they are in office and for two years thereafter, to hold any office, position, or employment in any member bank; nor while in office may they be an officer, director, or stockholder in any bank, banking institution,

trust company or federal reserve bank. Of the five members, at least two must be persons experienced in banking or finance. The term of office is 10 years unless the member is sooner removed by the President; one member's term expires every two years, so that at all times the board will have an experienced majority and a continuity of policy. Of the five members, one is designated by the President as governor and one as vice-governor of the board, the governor being the active executive officer of the board. Membership on the board gives the Secretary of the Treasury certain powers in addition to those previously possessed by him, and none of his powers as Secretary are qualified or limited because of his membership on the board.

Criticism of Constitution of the Board

The chief criticisms that have been brought against the constitution of the board are: that appointment thereto is owing to government officials rather than to banks, and therefore the board is too open to political influence; that it has too few bankers and too many without banking knowledge and experience, an equipment required for only two of the seven; that it is too powerful and arbitrary; and finally that the Comptroller should not be a member of the board. The political menace is undoubtedly the board's greatest danger, but so far in its history no charges of a political nature have been alleged against it, and the country has been fortunate in having some expert bankers and financiers as members. The contention that the Comptroller should not be a member of the board is debatable because it is he who links the supervision of the national banks as such with the general supervision of the whole system, including federal reserve, national, and member state banks and trust companies. It is also probably well to have the Secretary of the Treasury a member because of the paramount importance of government finance in its relation to banks and banking; indeed, to separate the Treasury and the board would lead to contrariety of purposes and consequent

difficulties. Some prominent bankers have complained of the dominance of the Treasury in the financial policy and conduct of the board; but this dominance is largely accidental and temporary, arising out of the exigencies of war finance.

Powers and Responsibilities

The board is responsible for the success of the system and is clothed with great powers, the chief of which are as follows:

1. To examine the federal reserve banks and member banks, and to require weekly statements from the reserve banks.
2. To permit or, on the affirmative vote of at least five members of the board, to require, federal reserve banks to rediscount the discounted paper of other federal reserve banks at rates fixed by the board.
3. To suspend reserve requirements for limited times under certain conditions.
4. To supervise and regulate, through the Comptroller of the Currency, the issue and retirement of federal reserve notes.
5. To add to the number of cities classified as reserve and central reserve cities, or to reclassify them, or to terminate their designation as such.
6. To suspend or remove any officer or director of any federal reserve bank.
7. To require the writing off of doubtful or worthless assets upon the books and balance sheets of federal reserve banks.
8. To suspend, for violations of law, the operations of any federal reserve bank, to take possession of it, administer it during suspension, and, when deemed advisable, to liquidate or reorganize it.
9. To require bonds of federal reserve agents; to make regulations for the safeguarding of all collateral, bonds,

federal reserve notes, money, etc.; to prepare rules and regulations for the conduct of all business required under the law; and to employ such attorneys, experts, etc., as may be deemed necessary to the conduct of the board.

10. To permit or compel federal reserve banks to establish branches within their districts, and to permit them to establish branches, agencies, or correspondents abroad or in our insular possessions, and to authorize member banks to establish branches abroad.
11. To require federal reserve banks to buy from member banks at par the 2 per cent bonds offered by them for sale.
12. To readjust federal reserve districts.
13. To assess the expenses of the Board upon the federal reserve banks.
14. To define the character of paper eligible for discount for member banks, and prescribe rules and regulations as to rediscounting and open-market operations.
15. To review and determine the rates of discount fixed by the federal reserve banks.
16. To act as a clearing house for the federal reserve banks, and to require the reserve banks to act as clearing houses for member banks.

Administrative Duties

The business of the Federal Reserve Board is handled through committees of the members, who prepare the matters to be acted upon and report them to the full board for determination. The board appoints all its officers and employees, with the exception of the governor and vice-governor, who are designated by the President. The main offices are in the Treasury Building at Washington, where meetings are held at various times during the week as business requires.

The administrative duties consist of such regular and recurring duties as approving discount rates, granting power to members to accept bills drawn upon them up to 100 per cent of their capital and surplus, preparation of reports, determination of salaries, passing on increases and decreases of capital stock of the reserve banks, and so forth, and of such occasional duties as may arise in the execution of the law.

During the period of organization and development the board had to determine its general policies and prepare rules and regulations governing the operations of the system. This work has been constructive and highly important, and in carrying it out the board consulted freely with reserve bank officials, the advisory council, and others. Periodical conferences are held with the various federal reserve agents and with the various governors of the federal reserve banks, both of which classes are organized and have frequent conferences among themselves. In this way a high degree of unity, uniform practice, and co-operation has been achieved in our system. The board refrains from interfering with the local administrative practice of the reserve banks except where necessary to effect uniformity.

The preparation of rules and regulations and of definitions is a very difficult and important part of the board's work. Even after the rules and regulations are fixed, they are subject to change, but since they affect vitally the conduct of banking and business in general, it is desirable that they be fixed in as nearly permanent a form as possible. The volume of this sort of work, however, will decline as the system gets established. The board has also been active in educational work, through the publication of reports, circulars, and press statements, and through lectures by its members.

The board has no source of income, but it has power to assess its expenses upon the federal reserve banks in proportion to their capitalization. The expenses, levied semiannually, amount to less than \$250,000 per year.

The Federal Advisory Council

The Federal Reserve Act provides for an advisory council consisting of as many members as there are districts. The board of directors of each federal reserve bank elects one member and determines his compensation subject to approval by the board. The meetings of this council are held at Washington at least four times a year, and oftener if called by the board. The council may meet elsewhere at such other times as it pleases. It elects its own officers and determines its own procedure. It has power to call for information regarding discount rates, rediscount business, note issues, reserve conditions in the various districts, the purchase and sale of gold and securities by the reserve banks, open-market operations by said banks, and the general affairs of the system, and to make recommendations concerning them; it can make oral and written representations regarding matters within the jurisdiction of the Federal Reserve Board, and it can confer directly with the board on general business conditions.

The council was created in response to the feeling that in the administration of the system the banks should be given an avenue of direct access to the responsible heads. It is wholly advisory. The practice has been for the reserve bank to elect some very prominent banker of its district, making membership on the council honorary and without compensation. Though composed of experts in banking, the council may not be able to give expert advice upon the operation of the reserve bank mechanism, for it has not the experience or information gained from conferences of the federal reserve agents or governors of the reserve banks, and most of the members' time is necessarily devoted to interests outside the reserve system. The term of office is but one year, although members may be re-elected. Even with such eligibility for re-election, however, the terms are likely to be short, and therefore the policies of the council tend to be less consistent and permanent and its work less efficient than if terms were long and there were rotation in office. The law does not confer clear and

definite responsibilities upon the council nor provide opportunities for broad usefulness. Nor is the authority granted to it necessarily exclusive, since other bodies may also advise with the board, as for instance, the officers of the American Bankers' Association, as well as the federal reserve agents and the governors of the reserve banks.

The Comptroller of the Currency—Powers and Duties

The National Banking Act of 1864 provided for the establishment of a separate bureau of the Treasury, under the Comptroller of the Currency, charged with the execution of that and subsequent laws respecting the issue and regulation of national bank notes. The Comptroller is appointed by the President, upon recommendation of the Secretary of the Treasury, for a term of five years at an annual salary of \$5,000. Neither the Comptroller nor his deputy may be interested directly or indirectly in any national bank.

The powers and duties of the Comptroller's office as they developed under the national bank laws were, in part, as follows:

1. To make investigations to determine whether a bank had satisfied the conditions prerequisite to issuing a certificate authorizing it to commence business; to issue such certificates or withhold them for good cause; to determine the maximum and minimum capitalization of a bank; to issue permits to increase or decrease the capital stock or to merge with other banks; to extend charters; to approve the name or change of name of a bank; to require and file oaths of directors; and the like.
2. To take possession of defaulting banks, appoint receivers, liquidate the banks, cancel their notes, and pay depositors.
3. To care for the issue, redemption, security, withdrawal, and cancellation of bank notes. This includes the engraving of plates and the making of dies and the

custody of same; the printing of new notes and the custody of new and old notes; furnishing notes to banks; issuing new notes for those worn or mutilated; calculating and watching the redemption fund; requiring deposits of bonds and increases of such deposits if values fall; examining bonds, notes, dies, etc.; transferring these bonds for owners; redeeming notes; etc.

4. To appoint examiners and conduct examinations of all national banks and of all banks in the District of Columbia.
5. To report to Congress annually the condition of the national banks, and of the state banks, banking companies, and savings banks.

The Federal Reserve Act as amended affects the Comptroller in several respects. By this act he is made *ex officio* a member of the Federal Reserve Board, and for his services in this connection is given \$7,000 additional salary. He is also made ineligible during his term of office and for two years thereafter to hold any office, position, or employment in any bank which is a member of the federal reserve system.

By the provisions of the act he is empowered to issue to federal reserve banks, upon deposit by them of bonds bearing the circulation privilege, federal reserve bank notes under the same conditions and provisions of law as govern the issue of national bank notes. He is given full charge of the execution of the laws governing the issue and retirement of federal reserve notes, under the general supervision of the Federal Reserve Board. To him the federal reserve agents return for redemption all federal reserve notes unfit for circulation, for which purpose a 5 per cent redemption fund is carried with the United States Treasury. It is no longer necessary for him to require the deposit of bonds and the taking out of national bank notes when a national bank is to be organized.

The Federal Reserve Act also changed the law with respect to the Comptroller's duties relative to bank examinations. The Comptroller now, with the approval of the Secretary of the Treasury, appoints examiners, who examine every member bank at least twice in each calendar year, and oftener if considered necessary. The Federal Reserve Board may, however, authorize examinations by the state authorities in case of member state banks and trust companies, and may direct special examinations of them. The examiners are clothed with ample powers and make full and detailed reports of conditions to the Comptroller. The expense of the examinations is assessed by the Comptroller upon the banks examined in proportion to assets of the various banks. The total assessment of examiners' fees for 1920 was \$1,184,026. As a condition of membership in the federal reserve system, state institutions are subject to examinations, made by direction of the Federal Reserve Board or of the federal reserve bank, by examiners selected or approved by the Federal Reserve Board. The national and state examiners co-operate increasingly, and this serves to effect better banking in both national and state banks.

In addition to examinations conducted by the Comptroller, the federal reserve banks may, with the approval of the federal reserve agent or board, provide for special examinations of members within their respective districts, and the expense of these special examinations also is borne by the examined banks. The object of these special examinations is to inform the reserve bank of the condition of its members and of the lines of credit which are being extended by them. The reserve bank must, at the request of the board, furnish such information as may be required concerning the condition of any member bank of its district.

The board is required to examine each federal reserve bank at least once each year, and upon the joint application of ten member banks to make a special examination of the reserve bank.

The Comptroller's Examiners

The Comptroller's examiners, on October 31, 1919, consisted of a field force of 128 national bank examiners and as many assistants, who were under the immediate supervision of twelve chief examiners located in the twelve federal reserve districts, the number in each district varying with the number and size of the banks. Each district is subdivided, and an examiner is assigned to each subdivision and operates under the chief examiner. The chief examiner, whose headquarters are at the federal reserve city, acts under the general supervision of the Comptroller. Each examiner is assigned about seventy banks for examination at least twice a year, and is furnished an assistant in connection with the examinations of the larger banks. The assistant examiners are attached to the office of the chief examiner of the respective districts and are subject to his instructions.

The examiners send their original reports, together with data concerning credit, reconciliation, and other matters taken up during the examination, to the office of the chief examiner, where the typewritten reports are prepared, forwarded to the examiner for his signature, and then transmitted to the Comptroller's office. The credit data are tabulated in the chief examiner's office. The chief examiner also makes the necessary reconcilements of accounts with other banks. A copy of each report of examination is furnished to the federal reserve bank and to the bank examined. Wherever state and national banks are operated in the same building, or are closely affiliated, the state and national bank examiners arrange, if possible, for simultaneous examinations, and if conditions warrant, they discuss together loans and other matters.

National Bank Reports

The Act of 1869, still in force, requires national banks to make each year not less than five reports to the Comptroller. At the call of the Comptroller a report of conditions on the specified past

date must be prepared and transmitted within five days, under penalty of fine, and must be published in a local newspaper. The Comptroller may require special reports for various purposes. At the time of declaration each bank is also to report each dividend declared and the amount of net earnings in excess of the dividends. Under the Act of 1917, state institutions becoming members are required to report to their federal reserve bank their condition and the payment of dividends. Not less than three such reports must be made annually on call of the federal reserve bank, on dates to be fixed by the Federal Reserve Board. The reports must be made within ten days of call under penalty of fine.

The supervision and regulation of the banks has exercised a beneficent influence upon banking in the United States. Uniformity of practice and accounting has made possible accurate comparisons between different banks and between conditions on different dates. Thus on the one hand fraudulent and dangerous practices have been reduced or eliminated, and on the other, good practices have been encouraged.

CHAPTER XVI

DOMESTIC AND FOREIGN BRANCH BANKING

Branch Banking Within the United States

Branch banking in the United States has always aroused much opposition, especially among the smaller banks, on the theory that it results in monopoly and is contrary to our democratic ideals, "the big banks eating up the little ones." In the fact of their private ownership our state and national banks afford a wide contrast to the system in vogue in Canada and in England where, indeed, the tendency to consolidation has been strongly evident for many years. In the last-named country, between 1891 and 1917 the number of private banks decreased from 37 to 6, and between 1886 and 1918 the joint-stock banks fell from 109 to 35, the number of branches of the latter increasing from 1,547 to 5,993, and the total liabilities increasing from £376,808,999 to £1,316,220,000. In 1917, however, the proposal to amalgamate two more of these large banks led to public outcry and adverse Parliamentary action.

The great objection to the concentration of banking resources is a fear of a "money trust," with results detrimental to the national interest; and the small trader fears that the big bank will favor the more important traders and dealers at his expense.

In order to guard against these evils, in the United States the law prohibits a national bank from acquiring and holding the stocks of another national bank as an investment. The reasoning behind this inhibition, according to our courts, is, that to permit one bank to invest its surplus funds in other banks situated perhaps at a distance would make it no longer possible to confine the management of each bank to persons who live in the neighborhood and who may be supposed to know the trustworthiness of

the appointed officers and the financial ability of applicant borrowers; and that such concentration of ownership would deprive the people of the advantages from bank competition.

Of course, the fundamental reason for establishing branches is to gather more business so that the economies of large-scale business can be realized and additional services performed. Since the branch bank need not be as fully equipped as an independent local bank, since its official list may be small, and since its accounting system may be combined with that of the parent bank, a branch can be operated at lower cost than an independent bank, and therefore branches can reach communities too small for independent banks. On the other hand, as compared with the independent bank, the parent and branch system may not be so alive to local needs, may be tardy in establishing branches, and may not adapt them to local conditions as fully.

State and National Branch Bank

In certain states, state banks and trust companies are empowered to establish branches in their home cities, elsewhere in the state or abroad, but even in those states the system has not spread as far as might be expected, because of the dogged hold and possession of the field by independent banks. The idea of branch establishment is, however, not strange to our banking thought as shown by the number of branches of state banks in the following representative states in 1920.

This argument against concentration is not altogether conclusive. In Canada, where conditions are similar to those in the United States, an efficient system of branch banking has arisen, and centralized ownership and direction do not seem to promote loose extensions of credit. The managements of local interior banks rely increasingly for credit data and advice upon the large metropolitan banks, and it is probable that a parent bank could function in this capacity even more effectually than a metropolitan correspondent. Besides, any locality large enough to support

two banks might find the competition of two branches of different parent banks quite as beneficent as the competition of two independent banks.

BRANCHES OF STATE BANKS IN REPRESENTATIVE STATES, 1920

Alabama.....	21	New Jersey.....	19
Arizona.....	21	New York.....	148
California.....	118	North Carolina.....	23
Delaware.....	10	Ohio.....	61
Georgia.....	32	Pennsylvania.....	12
Indiana.....	4	Rhode Island.....	13
Louisiana.....	50	South Carolina.....	14
Maine.....	25	Tennessee.....	16
Maryland.....	36	Virginia.....	20
Massachusetts.....	22	Washington.....	11
Michigan.....	72	Wisconsin.....	9
Mississippi.....	23		

Although a national bank may not directly establish a string of branches, this may be accomplished indirectly. A state bank having branches may become a national bank and retain its branches; the branches are then treated as if they had no separate corporate existence. A national bank, by purchasing a bank with branches and then liquidating the purchased bank, does not acquire the right to establish branches. A state bank joining the federal reserve system may retain its branches. National banks having branches within their domiciling states are (1921):

Location	Name of Bank	Number of Branches
New York, N. Y.	National City	3
New York, N. Y.	Chatham and Phoenix National	12
New York, N. Y.	Public National	5
San Francisco, Cal.	Bank of California	3 (diff. states)
Milton, Ore.	First National	1
Moss Point, Miss.	Pascagoula National	1
Greensboro, N. C.	American Exchange National	1
Lake Charles, La.	Calscieu National Bank of South- west Louisiana	8
Seattle, Wash.	Union National	2

Congress has recently considered the advisability of permitting national banks to establish branches in their home cities. Such legislation would put those national banks having no branches at present on a competitive equality with national and state banks that have branches. One state bank in New York City has forty branches in the city, and one national bank has twelve branches in New York City. The Federal Reserve Board favors permitting national banks of capital and surplus of \$1,000,000 or more, located in cities of 100,000 population or more, to establish not more than ten branches, each within their home cities.

Development of Branch Banking

Altogether it would seem that branch banking is an inevitable future development in the United States and that the state and national bank laws will be liberalized in this respect. It is a perversion of justice that in New York City three national banks should have branches while the others are denied this privilege, because it is impossible for the other national banks to acquire equivalent chains by the same process as did these three. The permission granted by certain states to their state banks to maintain branches puts the state and national banks on unequal competitive planes; the obvious remedy is that the National Bank Law permit national banks in such states to have branches under the same conditions and limitations as the state banks. It is to be remembered that in Canada, where economic and political conditions are similar to those in the United States, branch banking prevails. On the whole it does not appear that branch banking conflicts with the principles of sound banking.

Another method of obtaining advantages equivalent to those of a branch bank is to create subsidiary or affiliated banks or finance houses, controlled by various corporate devices. Numerous national banks have such affiliated savings banks, trust companies, cattle loan companies, bond houses, or other commercial

banks which specialize in one line of service or in service to one class of clientele. These may be run in conjunction with other banking houses. A good example is the Textile Banking Company, Inc., recently organized by officers of the Guaranty Trust Company and the Liberty National Bank of New York especially to serve the wholesale dry goods trade.

Need for Foreign Branches of American Banks

American banks have been slow to establish foreign branches. The National Banking Act gave the national banks no such right and in this respect most of the state banking laws followed the national law. Although some states permitted the establishment of branches abroad, the privilege was little used and the field was left to private banking houses, which did open some branches. The one notable success was the International Banking Corporation, which maintained a chain of banks, chiefly in the Orient. As a result of this abstention from the establishment of branches our banking system remained provincial, and we were obliged to depend upon foreign banking houses for accommodation to our traders. In contrast with this, the number of European banks having branches in foreign countries exceeds 100, and the number of branches exceeds 2,000. Of these about 100 are in South America, 300 in Asia, 400 in Africa, and 700 in Oceania.

The chief argument against domestic branch banking in the United States—that it is undemocratic and places powerful control over money in the hands of a few institutions—is not thought to apply in the case of foreign branches. Although it is a premise of American polity that it is dangerous to allow combinations in domestic trade and finance, the objections are not regarded as valid when applied to combinations for foreign trade, as witness the Webb-Pomerene Act for combinations to conduct foreign trade, and the Federal Reserve Act in its provisions for foreign branch banking. The fact is that the American banks have to face a fact and not a theory if they wish to develop inter-

national finance, and as the banks of foreign countries do own and operate numerous branches abroad, in order to meet the foreign competition it is necessary that the American banks establish branches likewise.

A fundamental purpose of the Federal Reserve Act was to provide for the extension of American banks into the foreign field, and one of the many provisions to this end was that which authorized national banks possessing a capital and surplus of \$1,000,000 or more to establish branches in foreign countries or possessions of the United States. Applications to establish such branches must first be approved by the Federal Reserve Board, which has power to reject an application if it regards as inadequate the amount of capital proposed to be set aside for foreign business, or if for other reasons it deems the establishment of the branch inexpedient. These branches are calculated to further foreign commerce and to act, if so required, as fiscal agents of the United States. The parent bank is required at all times to furnish information concerning the condition of such branches to the Comptroller of the Currency upon demand, and the Federal Reserve Board may order special examinations at its will. The accounts of each branch are conducted independently of the accounts of the other branches and of the parent, and at the end of each fiscal period the profit or loss from each branch is transferred separately to the general ledger of the parent. The question of reserves of foreign branches is left by the board entirely to the discretion of the parent institution.

Foreign Branch Banks Established

As a result of this provision of the Federal Reserve Act two national banks have opened foreign branches. The National City Bank of New York in 1920 operated a chain of 55 branches, located in Hispanic America, Europe, and South Africa. The First National Bank of Boston has one branch in Buenos Aires.

Another method of operating foreign branch banks is for a

national or state bank to organize under state charter a subsidiary corporation, which in turn opens and operates the foreign branches. Control of the subsidiary is retained by several means, such as making the stock of the subsidiary transferable only along with an equivalent number of shares of the parent bank, or having the shares of the subsidiary owned by the officers of the parent company, or making use of the legal privilege to invest 10 per cent of the parent company's capital and surplus in the subsidiary. Thus the International Banking Corporation is affiliated with the National City Bank of New York and operates 29 branches in the Far East, England, France, the Dominican Republic, and Panama. The Mercantile Bank of the Americas, affiliated with Brown Brothers and Company, J. and W. Seligman and Company, Guaranty Trust Company of New York, the National Shawmut Bank of Boston, the Anglo-London Paris National Bank of San Francisco, and the Hibernian Bank and Trust Company of New Orleans, has branches in Paris, Barcelona, and Madrid, and operates 31 other branches through affiliated chartered companies in Colombia, Peru, Venezuela, Brazil, Nicaragua, Cuba, and Costa Rica. The Asia Banking Corporation, closely affiliated with the Guaranty Trust Company of New York, operates eight branches in Manila and China. The Park-Union Foreign Banking Corporation, affiliated with the National Park Bank of New York and the Union Bank of Canada, operates five branches in Paris, China, and Japan. On the other hand, the First National Corporation of Boston (affiliated with the First National Bank of Boston), the Shawmut Corporation (affiliated with the Shawmut National Bank of Boston), the French-American Banking Corporation of New York (affiliated with the National Bank of Commerce of New York, the First National Bank of Boston, and the Comptoir National d'Escompte de Paris), and the Foreign Credit Corporation of New York, have not as yet opened foreign branches.

All the above have one or two branches each within the

United States and are carrying on business under an agreement with the Federal Reserve Board. The charters of these subsidiary corporations are liberal indeed; for instance, that of the International Banking Corporation, chartered in Connecticut, after specifying a long list of activities in which the corporation may engage, allows it "to transact and engage in any other lawful business whatsoever." For the most part, however, these corporations actually engage in nothing but purely banking business. Exceptions in this respect are the Mercantile Bank of the Americas—which operates a subsidiary, the Mercantile Overseas Corporation, for trade and development work in foreign countries—and the Foreign Commerce Corporation of America established by the Morgan interest to engage in foreign trade.

In order to give all national banks, little as well as big, an opportunity for sharing in the benefits of foreign trade, the Federal Reserve Act was amended September 7, 1916, to permit any national bank to subscribe an amount not exceeding 10 per cent of its capital and surplus to stock of banks organized to transact a foreign banking business. These banks are authorized to receive only such deposits in this country as may be incidental to or connected with their foreign business. They are authorized to establish branches abroad or they may operate through agencies there, and they may have either state or federal charters. Before the board authorizes them to operate they are obliged to enter an agreement to restrict their operations according to the limitations set by the board; failure to comply with these regulations, or failure of the parent or branch, may lead to the revocation of their right to do business. Under this scheme of cooperative ownership several institutions have been opened by groups of national banks and foreign branches or connections have been established; for example, the American Foreign Banking Corporation, owned by banks all over the United States and Canada, and the International Acceptance Bank, Inc., owned by bankinghouses of the United States, Switzerland, Holland, Sweden,

and England, and closely co-operating with the French-American Banking Corporation of New York, the American International Corporation of New York, and other foreign banking institutions.

Ownership and Management of Foreign Branches

A committee of government experts in foreign trade recently considered the question of the character of the agencies most desirable for banks to maintain in foreign countries—whether they should be branches in the strict sense of the term, or independent banks affiliated with American banks the capital of which would be supplied wholly or partly by the American banks, or, finally, whether they should be local banks already in operation, control being secured through the purchase of the majority of their stock. The committee did not formulate any definite conclusions; it did recognize, however, the advantages resulting from the association of local capital with a foreign branch bank undertaking, and from securing the co-operation of natives through their representation on the board of directors or in the management of the branches. It also urged the importance of foreign branches of American banks being, so far as practicable, under the management of American citizens, and the importance of employing American banking methods. As banks are constantly in receipt of valuable information regarding investment and trade opportunities, it was thought highly desirable that the officers to whom this information came should, as a result of their nationality, be interested in the promotion of the interests of the United States rather than those of a third country.

Growth and Functions of Foreign Branches

The growth of foreign branch banking has been promoted by the war and the consequent increase of our foreign trade, and, on the other hand, it has been a leading factor in developing that trade. Branch banks push the financing of foreign trade in their areas, through the parent bank and in dollar exchange; and

through its branches the parent bank obtains an accurate knowledge of the standing and credit of foreign merchants, so that it can act as adviser of American exporters. The branches are ready to negotiate drafts on foreign acceptors and to act as agents for the collection and transmission of proceeds of items. They also perform other financial functions in the payment of debts between the countries (covering imports, exports, travel, interest, loans, etc.), and also the ordinary local banking services in their areas, such as receiving deposits, making loans, and granting discounts. In addition the branches may be used by the parent bank to gather special information and make daily reports on the trade, industrial, and commercial conditions of their areas.

Federal Foreign Banking Associations

In 1919, after the "peg" was removed from sterling, franc, and lire exchange, rates declined to hitherto unknown levels and speculation in exchange became excessive. American exporters suffered, and a wide demand arose to have the exchange situation "corrected." The needs of "suffering Europe" also played a prominent rôle in the plea for action. Various private and public proposals were presented, and some were adopted. Among these was the plan of Senator Edge of New Jersey, who advocated the federal incorporation of companies engaged in foreign banking and finance, with the multiplex object of remedying the exchange situation, extending quick credits to European purchasers, and thus increasing the demand for our exports, stimulating our foreign trade, and developing our new merchant marine. The general purpose was "to provide for the establishment of a federal system of international banking or financial corporations operating under federal supervision with powers sufficiently broad to compete with similar foreign institutions and to afford to the American exporter and importer at all times a possible means of financing his foreign business."

This act logically follows previous legislation to promote

foreign trade. The Federal Reserve Act of 1913 enabled national banks with a capital and surplus of at least \$1,000,000 to establish branches abroad. An amendment in 1916 permitted banks of this size jointly to establish and own such American banks or corporations as were principally engaged in foreign banking, by investing up to 10 per cent of their capital and surplus in such institutions "incorporated under the laws of the United States or of any state thereof"; but no provision existed at that time for federal incorporation of such institutions in which it authorized national banks to invest. And in 1919 the McLean Act was passed providing that national banks, without regard to the amount of their capital and surplus, might subscribe up to 5 per cent of their capital and surplus in stocks of federal or state corporations principally engaged in such phases of international financial operations as might be necessary to facilitate exports from the United States. The McLean Act enabled national banks to invest in the stocks of corporations whose business was more in the nature of an investment company's than that of a commercial banking institution.¹

Before the passage of the Edge Act certain foreign banking corporations had been established under state law; for instance, the Asia Banking Corporation, the Foreign Discount Corporation, the Mercantile Bank of the Americas, Inc., etc. Some of these corporations were operated partially under control of the Federal Reserve Board in cases when national banks contributed to their capital, since they were then required to restrict their business according to rules and limitations set by the board. In the passage of the Edge Act, however, it was thought that control through agreement with the board was not as satisfactory as that exercised through incorporation under federal law. It was felt that the time would come when the conflict of dual control by the board and the state banking departments might prove embarrassing or might operate to restrict the activities of the corporation,

¹ See Federal Reserve Bulletin, Jan. 1921, pp. 71-72.

and that a banking corporation, being essentially a national enterprise with some of its stock owned by national banks, should have the protection of a federal charter and enjoy the prestige of such charter in foreign trade competition.

Provisions of the Edge Act

The Edge Act became law in December, 1919. It allows federal incorporation of two kinds of banking institutions, which, however, are not clearly distinguished—one doing principally commercial banking, and the other modeled upon the “investment trust” of European countries doing an investment business. Five or more natural persons may procure a federal charter running twenty years, under a name approved by the Federal Reserve Board. Its capital must be at least \$2,000,000, and one-tenth of the net proceeds must be carried to surplus until the amount thus set aside equals 20 per cent of the capital. A controlling interest in the corporation must at all times be owned either by—

1. Citizens of the United States.
2. State or federal corporations in which the controlling interest is owned by citizens of the United States.
3. Firms or companies in which the controlling interest is owned by citizens of the United States.

National banks may invest in the stocks of the Edge corporations, but the aggregate amount of stock held by a bank in all Edge corporations together with its stock in those corporations described in Section 25 of the Federal Reserve Act as amended, authorizing national banks to establish branches abroad, may not exceed 10 per cent of its capital and surplus. The act provides for the conversion of state corporations into Edge corporations, with the approval of the board.

The directors of an Edge corporation must be citizens of the United States, and a member of the Federal Reserve Board is disqualified from being an officer, director, or shareholder, either in

an Edge corporation or in a similar institution chartered by a state. The Clayton Act was amended to extend its prohibitions of interlocked directorates to the Edge corporations; but a director, officer, agent, or employee of a national bank may serve at the same time in an Edge corporation, with the permission of the Federal Reserve Board; and a director, officer, agent, or employee of an Edge corporation is not prohibited from serving, with the approval of the board, in any other corporation in which the Edge corporation has invested.

Powers of the Edge Corporations

The Edge corporations enjoy general banking powers; to handle all forms of commercial instruments; to deal in securities, including those of the United States and of any state; to accept bills drawn upon them, subject to regulations and limitations imposed by the Federal Reserve Board; to issue letters of credit; to deal in coin, bullion, and exchange; to borrow and lend money; to issue debentures, bonds, and promissory notes, subject to conditions and restrictions imposed by the board, to an amount not exceeding at any one time ten times the capital and surplus of the issuing corporation; to receive deposits outside the United States and such deposits inside the United States as may be incidental to its foreign operations (against which domestic deposits it must carry reserves prescribed by the Federal Reserve Board amounting to not less than 10 per cent); to do all things deemed by the board as incidental to the transaction of its business of banking and finance in foreign countries; to establish branches and agencies abroad, in places approved and under regulations prescribed by the board.

An Edge corporation may purchase and hold stock in any other Edge corporation or in a corporation organized under the laws of any foreign country or of any state or dependency of the United States, on condition that such corporation does not engage in merchandise business inside the United States except to the

extent that the board may decide is incidental to its foreign business. It may not invest in any one corporation in excess of 10 per cent (15 per cent in case of banking corporations) of its own capital and surplus, without the approval of the board. Nor may it own stocks in any other corporation, organized under the Edge Act or state law, which is in substantial competition with it, or which holds stock in corporations which are in substantial competition with the purchasing corporation. Edge corporations may not become members of the federal reserve system, and they are prohibited from carrying on any part of their business inside the United States, except as the board deems it incidental to the foreign business. They are also prohibited from merchandising in commodities and from directly or indirectly controlling or fixing prices of the merchandise, a prohibition conforming to the American policy of separation of trading and banking.

Edge Corporations Established

It is thus seen that the Federal Reserve Board is clothed with broad powers for the regulation and control of the Edge corporations, and upon this regulation their success and avoidance of danger largely depend. The first set of regulations was issued² in March, 1920. Another potent factor determining the success of the Edge corporations is their ability to distribute among investors in this country the obligations that they may indorse or may issue against the foreign obligations they may acquire. Being a new form of banking institution it will require considerable publicity and propaganda to induce the participants in foreign trade to use them. Their development is also being promoted by the fact that in the different states (already 19) the "blue sky" restrictions forbidding one bank to hold for investment stock in another bank have been cleared away.

Of the several Edge corporations already established the First Federal Foreign Banking Association of New York was organized

² Federal Reserve Bulletin, Apr. 1920, pp. 379-382.

by financial interests of New York and New England, in the interest of the manufacturers of their localities.

The Foreign Trade Financing Corporation of New York was launched during the economic depression in the winter 1920-1921, at a Chicago conference of some 500 representatives of the banking, commercial, agricultural, and industrial interests of every section of the country, with a view to extending long-term credits to foreign buyers of American goods and thus terminating the threatened paralysis of our international trade. The corporation is capitalized at \$100,000,000, the shares being held broadly throughout the country, and it may issue \$1,000,000,000 of debentures for sale to investors of all classes throughout the United States and elsewhere, if deemed desirable. The corporation is establishing branches in different parts of the United States as well as agencies in foreign countries.

A third Edge corporation, the Federal International Banking Company of New Orleans, was also founded during the depression in the winter of 1920-1921, by southern bankers, for the purpose of lending financial aid in the exportation of cotton and other southern products. It is capitalized at \$6,000,000, with shares held throughout the cotton states, in whose larger cities branches and agencies are being located.

CHAPTER XVII

LEGISLATION GOVERNING NATIONAL BANK NOTE ISSUE

Bond Deposit Requirement from 1864 to 1900

The National Banking Act of 1864 required, as a preliminary to the issue of national bank notes, a deposit of United States registered bonds to an amount not less than one-third of the paid-in capital stock of the bank and in a sum not less than \$30,000. On these deposited bonds the bank could issue circulating notes, but not to an amount exceeding 90 per cent of the market value of the bonds, nor 90 per cent of their par value, nor to an amount exceeding the bank's paid-in capital. The aggregate limit was fixed at \$300,000,000. In the following year the act was amended, limiting the issue of circulation as follows: to banks with capital of \$500,000 or less, 90 per cent of the capital; over \$500,000 up to \$1,000,000, 80 per cent; over \$1,000,000 up to \$3,000,000, 75 per cent; and over \$3,000,000, 60 per cent. It was further provided that of the aggregate amount authorized, one-half should be divided among cities and territories according to population, and the other half should be apportioned by the Secretary of the Treasury among the states according to the banking capital, volume of business, and so forth.

The Act of 1870 authorized the issue of additional circulation to the amount of \$54,000,000, but provided that no bank organized thereafter should issue circulation in excess of \$500,000. This extra issue was to be divided among the states on the basis of the census of 1870. This act also authorized the organization of banks to issue circulation redeemable in gold, but limited the amount to be issued by each "gold bank" to 80 per cent of the par value of the United States bonds deposited, and to a maxi-

mum of \$1,000,000; these notes were of different denominations (none less than \$5), were payable on demand in gold, and were a legal tender at par in payments to every other such "gold bank." Against these notes the banks were to hold on hand not less than 25 per cent of their outstanding circulation in gold or silver coin.

In 1874 an act was passed establishing the national bank redemption agency and providing for the retirement of circulation and withdrawal of bonds; it also changed in part the provisions of the original law with respect to the bond deposit requirement, in that banks with capital in excess of \$150,000 were permitted to reduce their bond deposit to \$50,000. This reduction determined the minimum bond deposit required of banks with capital in excess of \$150,000. Six months later the limit on the aggregate amount of national bank note circulation was repealed, and every bank was permitted to issue circulation secured by bonds to the extent of 90 per cent of its paid-in capital.

Prior to 1880 it became apparent that there was no demand for gold banks, only ten having been organized, all in California, and in that year their conversion into currency banks was authorized. Within a short time thereafter all the gold banks were either closed or converted into currency banks. The chief reasons for the failure of the gold banks were: (1) their highly localized distribution, (2) the opposition of the Californians to their notes after the panic of 1873, since they were paper rather than metal money, and (3) the meager profit possible from the note issue privilege inasmuch as the notes issuable were limited to 80 per cent of the par value of the bonds and the market rate of interest was high in the state of California.

The bond deposit requirement was again amended in 1882, to the effect that banks with capital of \$150,000 or less were compelled to deposit, as security for circulation, bonds to the amount of one-fourth of their capital only. Those banks having on deposit bonds in excess of that amount were authorized to reduce their circulation by depositing lawful money for redemption of

the notes and to withdraw bonds, but no bank reducing its circulation could again receive any increase of its circulation for a period of six months after the time it deposited money for the reduction, nor could more than \$3,000,000 lawful money be deposited to retire circulation in any one calendar month.

The circulation franchise was given an added value by the Act of March 14, 1900, which authorized the issue of circulation to the par value of the bonds deposited, reduced the tax on circulation secured by 2 per cent consols to $\frac{1}{4}$ per cent semiannually, and repealed the provision of the Act of 1882 forbidding the increase of circulation within six months from date of decrease.

The Aldrich-Vreeland Act—Emergency Circulation of Associations

On May 30, 1908, the Aldrich-Vreeland Act was passed in order to provide emergency circulation, the need for which had been severely felt during the panic the previous year. By this act ten or more national banks, which individually had an unimpaired capital and surplus of not less than 20 per cent and collectively an aggregate capital and surplus of at least \$5,000,000, were permitted, with the approval of the Secretary of the Treasury, to form voluntary associations known as "national currency associations." Not more than one such association could be formed in any city, the uniting banks were to be located in a contiguous territory, and no bank could belong to more than one association. Each association was given a corporate entity and was to be managed by a board consisting of one representative from each bank, and its business was to be done by duly appointed officers.

For the purpose of obtaining additional circulation, any bank belonging to such an association, which had notes outstanding secured by the deposit of United States bonds to an amount not less than 40 per cent of its capital and had its capital unimpaired and a surplus of not less than 20 per cent might deposit with and

transfer to the association, in trust for the United States, such securities as were satisfactory to the directors of the association. The officers of the association then might make application to the Comptroller of the Currency, for an issue of circulating notes. The Comptroller would forward the application to the Secretary of the Treasury with such recommendations as he might think proper. If the Secretary judged the business conditions in the locality demanded additional circulation, and if he were satisfied with the character and value of the securities offered and that the lien of the United States on the securities so deposited and on the banks composing the association was amply sufficient for the government's protection, he might then direct the issue to the association, on behalf of such bank, of additional notes to an amount fixed at his discretion. This amount, however, could not exceed 90 per cent of the cash value of the municipal securities and 75 per cent of the other securities deposited, but in any event no bank could be authorized to issue notes based on commercial paper in excess of 30 per cent of its unimpaired capital and surplus. Commercial paper was defined as including only notes representing actual commercial transactions, which, when accepted by the association, bore the names of at least two responsible parties and had not more than four months to run.

All the members of these various national currency associations were jointly and severally liable to the United States for the redemption of such additional circulation, and the government took a lien on the securities deposited and the total assets of the member banks. As among the several banks composing an association each bank was liable only in the proportion that its capital and surplus bore to the aggregate capital and surplus of all such banks. The association was empowered to call at any time for additional securities or commercial paper, and to require the exchange of other securities. In case a member failed to comply with this demand the association had power to sell at public sale the securities and paper on hand and deposit the proceeds with

the United States Treasury for the redemption of the additional circulation, and if the proceeds of this sale were insufficient to redeem the circulation the association could recover in court from the bank and have the benefit of the government's lien on the bank's assets.

Emergency Circulation of National Banks

The Aldrich-Vreeland Act also provided that national banks having bank notes outstanding secured by the deposit of United States bonds to an amount less than 40 per cent of its capital, and having a surplus of not less than 20 per cent, might make application to the Comptroller of the Currency for authority to issue additional notes to be secured by the deposit of bonds other than those of the United States. The Comptroller was to transmit this application, with his recommendation, to the Secretary of the Treasury, who, if he judged that business conditions in the locality demanded additional circulation, would approve the application, determine the time of issue, and fix the amount of the additional circulation within the limits imposed by law.

After the Secretary of the Treasury had approved the character and amount of the deposited bonds, the applying bank was entitled to receive from the Comptroller notes in blank, not exceeding 90 per cent of the market value and not in excess of the par value of any bonds so deposited. The Treasurer of the United States, with the approval of the Secretary of the Treasury, was to accept, as security for the additional circulating notes, bonds or other interest-bearing obligations of any state of the United States, or any legally authorized bonds issued by any city, town, county, or other legally constituted municipality or district in the United States conforming to certain prescribed conditions as to age, financial record, and condition; the Treasurer was to determine the relative proportions of these securities which were accepted by him, and he was empowered to require additional securities and substitute securities.

Character of the Emergency Notes

The additional circulating notes issued under the Aldrich-Vreeland Act were of the same nature, tenor, and use as the circulating notes of national banks previously issued and secured by the deposit of United States bonds. The total amount of outstanding notes of any bank, including the additional issues, was not at any time to exceed the bank's unimpaired capital and surplus, and the maximum total issue was limited to \$500,000,000. The additional issues were to be distributed by the Secretary of the Treasury among the states on the basis of the proportion which the unimpaired capital and surplus of the national banks in the state bore to the total amount of these items for all national banks of the United States. Any national bank having circulating notes secured otherwise than by bonds of the United States was required to pay for the first month a tax at the rate of 5 per cent per annum upon the average amount of such of its notes as were based upon such securities, and afterwards an additional tax of 1 per cent per annum for each month until a 10 per cent per annum tax was reached, and thereafter a 10 per cent per annum tax. Reports of such note issues were required from the banks monthly. The taxes were paid into the redemption fund. For the retirement of the additional circulation the issuing bank was authorized to deposit lawful money or national bank notes.

The Aldrich-Vreeland Act was to expire, by the terms of the act, on June 30, 1914. Between the crises of 1907 and 1914 there was no unusual demand for currency and therefore no issues of national bank notes on other security than United States bonds. Quite a number of these associations were organized in these five years, and \$500,000,000 of the emergency notes were printed and deposited in the sub-treasuries against the day of need.

The Aldrich-Vreeland Act was understood to be only a makeshift and temporary arrangement until the National Monetary

Commission made its report and a new banking plan was established. When the Federal Reserve Act was passed in December, 1913, provision was made to extend to June 30, 1915, the time for the expiration of the Aldrich-Vreeland Act, which was retained as the means of an emergency currency until the federal reserve system was well established. Also at this time the taxes on the circulating notes secured otherwise than by bonds of the United States were reduced to 3 per cent per annum for the first three months, with an additional tax of $\frac{1}{2}$ per cent per annum for each month until a tax of 6 per cent per annum was reached; thereafter a tax of 6 per cent per annum was to prevail.

Effect of War on Emergency Circulation

On August 4, 1914, at the opening of the Great War and the consequent disturbance of financial conditions, the Federal Reserve Act and the Aldrich-Vreeland Act were further amended. By these amendments the Secretary of the Treasury was given power to suspend, whenever he deemed it desirable, the limitations of the law which prescribed that additional circulation, secured otherwise than by bonds of the United States, could be issued only to those national banks which had circulating notes outstanding, secured by the deposit of United States bonds to an amount not less than 40 per cent of the capital stock. He could also suspend the limitation that the total issue of additional notes could not exceed \$500,000,000, and that the total issue of any bank could not exceed the amount of its unimpaired capital and surplus, the maximum issue of any bank being also fixed at 125 per cent of its unimpaired capital and surplus. The privileges of the amended acts were also extended to state banks and trust companies which were members of the federal reserve system.

The Aldrich-Vreeland Act thus amended was put into immediate effect. The record is best told by the following statistical statement:

EMERGENCY CIRCULATION, 1914-1915

(In millions)

	U. S. Bonds on Deposit	Issue Value of Miscellaneous Securities	Circulation Secured by:			Total Circulation Outstanding
			U. S. Bonds	Miscellaneous	Lawful Money	
1914						
Jan. 31..	\$741.6	\$736.6	\$17.8	\$754.0
Feb. 28..	741.4	736.6	16.7	753.2
Mch. 31..	740.6	735.4	16.6	752.0
Apr. 30..	741.2	736.2	15.6	751.8
May 31..	740.8	735.4	16.1	751.6
June 30..	740.8	735.5	15.1	750.7
July 31..	740.2	735.2	15.7	750.9
Aug. 31..	743.3	\$126.9	735.9	\$126.2	15.4	877.5
Sep. 30..	744.5	344.8	737.1	325.0	15.8	1,077.9
Oct. 31..	744.7	365.2	739.7	361.1	20.6	1,121.5
Nov. 30..	744.6	272.5	740.5	270.1	101.4	1,111.9
Dec. 31..	744.4	152.7	720.3	150.8	168.5	1,039.7
1915						
Jan. 31..	742.0	68.5	723.2	67.3	191.7	982.2
Feb. 28..	737.9	32.2	716.8	31.1	190.1	938.0
Mch. 31..	736.1	15.1	718.9	15.1	165.4	899.5
Apr. 30..	736.1	6.7	722.2	6.5	139.0	867.8
May 31..	736.1	2.5	725.7	2.5	112.1	840.3
June 30..	735.0	.7	725.3	.7	93.2	819.3
July 31..	735.6	.2	723.6	.2	80.8	804.6
Aug. 31..	735.5	.2	722.9	.2	70.6	793.8
Sep. 30..	735.6	.2	722.8	.2	63.8	768.7
Oct. 31..	735.1	.2	722.7	.2	56.9	779.9
Nov. 30..	731.5	.0	720.6	.0	55.7	776.4
Dec. 31..	730.3	719.6	51.8	771.3

The additional circulation authorized and secured by commercial paper represented $57\frac{1}{2}$ per cent of the total authorized; by miscellaneous securities, including industrial bonds, and other securities, mainly city and town notes and warrants, 28 per cent; by state, county, and municipal bonds, 14 per cent; and by notes secured by warehouse receipts, $\frac{1}{2}$ per cent.

Although there were between 7,500 and 7,600 national banks in active operation at this time, and 45 national currency associations organized, the membership of these associations was but 2,197, and of that number only 1,363 took out additional circula-

tion. All the states of the Union except Maine and Wyoming were included in one or more of the currency associations, but in nine of the states not a single national bank applied for additional circulation, and of the authorized issue 80 per cent was for banks in the reserve city associations, the amount for New York City banks being \$144,975,960.

The tax collected on this additional circulation for the fiscal year 1914-1915, which practically covers the period of the issue, was \$2,977,066.73. As the tax was not applied until the notes were actually put into circulation, many banks took out notes for which they had no immediate need and held them in their vaults against emergency.

Conversion and Refunding of Bonds under the Federal Reserve Act

The Federal Reserve Act repealed the provisions of Section 5159 of the Revised Statutes of the United States and of the Acts of 1874 and 1882, and any other provisions of existing statutes that required national banks to deposit a stated amount of bonds with the United States Treasurer before being authorized to commence banking business.

The Federal Reserve Act also provided for the retirement of the national bank circulation, and for the sale and transfer to the federal reserve banks of the United States bonds securing circulation. A member bank desiring to retire the whole or a part of its circulating notes is empowered at any time during a period of twenty years after December 23, 1915, to file with the Treasurer of the United States an application to sell for its account, at par and accrued interest, the United States bonds securing the circulation to be retired. The Treasurer is required to furnish the Federal Reserve Board, at the end of each quarterly period, with a list of such applications; and the board may in its discretion require the federal reserve banks to purchase such bonds from the banks whose applications have been filed with the Treasurer at

least ten days before the end of the quarterly period at which the board may direct the purchase to be made. But the federal reserve banks cannot be required to buy an amount to exceed \$25,000,000 of such bonds in any one year, this amount including all such bonds which they may have bought in the open market. The board is required to allot to each federal reserve bank such proportion of these bonds as the capital and surplus of the bank bear to the aggregate capital and surplus of all the federal reserve banks. When such sales are made the member bank assigns and transfers the bonds to the federal reserve bank purchasing them; the reserve bank pays the purchase price in lawful money to the United States Treasurer, and the Treasurer in turn pays the selling bank any balance due after deducting a sufficient sum to redeem its outstanding notes secured by such bonds. When redeemed these notes are canceled and permanently retired. The federal reserve bank purchasing such bonds is permitted to take out an amount of circulating notes equal to the par value of the bonds. These notes, known as "federal reserve bank notes," have the same tenor, qualities, basis, and method of issue and redemption as national bank notes, except that they are not limited to the amount of the capital of the federal reserve bank issuing them.

The Federal Reserve Act went further and provided for the conversion of the 2 per cent bonds bearing the circulation privilege, but not having any circulation outstanding at the time, into 3 per cent securities without the circulation privilege. Upon application of any federal reserve bank, approved by the Federal Reserve Board, the Secretary of the Treasury may issue, in exchange for the United States 2 per cent gold bonds bearing the circulation privilege but against which no circulation is outstanding, 1-year United States 3 per cent gold notes without the circulation privilege, to an amount not to exceed one-half of the 2 per cent bonds so tendered for exchange, and 30-year 3 per cent gold bonds without the circulation privilege for the remainder of the

2 per cent bonds so tendered. In obtaining the 1-year notes, however, the federal reserve bank enters into a contract with the Secretary of the Treasury to purchase, if the Secretary so requests, from the United States for gold, at the maturity of these 1-year notes, an amount of 1-year notes not to exceed those originally received from the Secretary in exchange for the 2 per cent bonds, this obligation to buy notes at each maturity of the previous issue continuing for a period not to exceed 30 years. The Treasury notes so issued are to run not longer than one year, are to be issued at par, in coupon or registered form, in denominations of \$100 or multiples thereof, are to bear 3 per cent interest payable quarterly, redeemable at maturity in gold, and are exempt from payment of all taxes of the United States (except as provided by this act) and of state, municipal, or local taxes. The bonds, on the other hand, are payable in 30 years, bear 3 per cent interest, and are like the United States bonds without the circulation privilege. Upon application of any federal reserve bank, approved by the board, the Secretary may issue at par such 3 per cent bonds, to take up the 1-year gold notes. The Secretary may convert any amount of 2 per cent bonds that he deems best, and the establishment of such amount is a matter to be annually determined in accordance with the requirements of the situation.

Effect of Liberty Bond Issues on Bond Refunding and Conversion

Bond refunding and conversions were well under way during 1916 and the first quarter of 1917. But the process was halted by the Liberty bond issues. Before that date the 3 per cent conversion bonds could be sold at a premium, and it was profitable to the federal reserve banks to buy the 2 per cent bonds at par, convert them into 3's, and sell at a premium. The 3 per cent notes could also be sold at a premium, but the reserve banks chose to keep them as an investment. But the issue of 3½ per cent Liberty Loan bonds destroyed the market for 3 per cent conversion bonds, and sales at par were no longer possible. At

this time 3 per cent conversion bonds were held by the reserve banks to the amount of \$7,000,000.

To remedy this condition a proposal has been made to raise the rate on future issues of conversion bonds to $3\frac{1}{2}$ per cent. But the Federal Reserve Board hesitated to encourage the conversion of bonds in this or other ways, deeming it best during the war to hold the 2 per cent bonds with the circulation privilege rather than the conversion 3 per cent bonds without the privilege, so that in an emergency the volume of federal reserve bank notes might be expanded. On December 31, 1919, the aggregate holdings of the twelve federal reserve banks were \$18.6 million of bonds with the note issue privilege, and \$6.5 million of 3 per cent conversion bonds. From the fact that some \$16 million of the privileged bonds bear but 2 per cent interest, it is evident that the federal reserve banks are not trying to make maximum earnings from this investment. In 1916 the Federal Reserve Board encouraged the federal reserve banks to buy the 2 per cent bonds, but discouraged the issue of federal reserve bank notes upon them; or, if such notes were issued to a reserve bank, the board favored the bank's holding them in its vaults against a time of stress. The policy of the Treasury has been to redeem the 1-year 3 per cent gold notes issued in connection with the conversions for the federal reserve banks.

Retirement of National Bank Notes

One of the fundamental purposes of the federal reserve system was to eliminate the bond-secured note circulation and substitute the federal reserve note based on commercial paper and gold. The sudden withdrawal of the national bank notes was not feasible, since they constituted a large fraction of our circulating media—in recent years averaging between \$700 and \$750 million—and to withdraw them would cause a violent contraction of the currency and of credit and a fall in prices. The plan adopted limits the maximum yearly reduction to \$25,000,000, at which

rate, if the banks made regular applications for the full amount and if the federal reserve banks bought such bonds only from the national banks and not in the open market, it would be 30 years before all the national bank notes were retired. The law, however, limits the retirement operations to 20 years and to the 2 per cent bonds; it was not, therefore, the contemplation of the law to provide for full retirement, which Congress may have regarded as less conservative and safe than the present plan. Special laws, of course, may be passed later to hasten and extend the retirement if it is found desirable.

No provision is made whereby the board is directed to give preference to the 2 per cent bonds of a bank which is forced to liquidate and throw its bonds on the open market. The board is also without instructions as to the amount of bonds which it shall require the reserve bank to buy from any particular bank. During 1916 the purchases of 2 per cent bonds by the federal reserve banks exceeded the \$25,000,000 maximum which the board can compel the reserve banks to buy in any one year, and it was found unnecessary, therefore, to direct the purchase of such bonds.

The purpose of the conversion plan of the act is to maintain the market value for the 2 per cent bonds and to insure a gradual retirement of national bank notes, any resulting deficiency in the volume of circulation being made up with federal reserve bank notes.

The Pittman Act of 1918

The occasion of the Pittman Act was explained in Volume I, Chapter I, as the sudden and pressing need for a great quantity of specie to pay the adverse trade balance with India during the war, and the desire to conserve the gold supply for reserve purposes. There were other incidental purposes, such as the stabilization of the price of silver and the encouragement of its production.

The act authorized the Secretary of the Treasury to reduce and sell as bullion silver dollars up to \$350 million, then held in

the Treasury, and to retire the silver certificates outstanding against the silver dollars so destroyed. To prevent contraction of the currency as the certificates were retired, the Federal Reserve Board was authorized to permit or require the federal reserve banks to issue federal reserve bank notes, in any denomination authorized by the board, to an amount equal to the silver melted and sold. In order to secure these bank notes the federal reserve banks were to deposit with the Treasurer of the United States certificates of indebtedness and 1-year gold notes. The Treasurer was permitted to extend the time of the certificates so deposited or to pay them before maturity, at his option, and the tax on the federal reserve bank notes so issued was to be so adjusted that the net return on the certificates of indebtedness and the gold notes would equal the net return on the United States 2 per cent bonds used to secure federal reserve bank notes. The Treasurer issued 2 per cent 1-year certificates for this specific purpose. In all other respects the federal reserve bank notes are like those provided for under the Federal Reserve Act.

Under this law, up to May 6, 1919, the date of the final transaction, the total amount of silver so reduced was \$260 million, and up to December 31, 1919, there had been issued \$259.4 million of federal reserve bank notes, mostly of \$1 and \$2 denominations.

The Pittman Act further provides that the Director of the Mint, at the instance of the Secretary of the Treasury, is to buy, at a maximum price of \$1 per fine ounce, enough silver from the product of American mines to replace that melted and sold. Accordingly, the Director of the Mint is now (1921) buying silver at 99.5 cents, which is nearly twice the market price of foreign silver. When silver dollars have been coined from the silver thus purchased, the Federal Reserve Board may require the federal reserve banks to retire an equal amount of federal reserve bank notes, and the Secretary of the Treasury will pay off an equal amount of the certificates of indebtedness.

The Deposited Bonds

National banks wishing to issue bank notes are required to deposit with the Treasurer of the United States registered bonds of the United States. The Treasury stands ready to exchange for this purpose registered bonds for coupon bonds which have the same par value, bear the same rate of interest, and run for the same period. A bank desiring to take out circulation remits the necessary bonds to the Comptroller of the Currency to be placed by him in the custody of the Treasurer, who gives a receipt in duplicate, one copy of which is sent to the bank and the other retained by the Comptroller, the bank bearing the expense incident to sending the bonds to the Comptroller. The bonds are assigned by the cashier or other officer of the bank to the "Treasurer of the United States in trust for the National Bank of . . ." The bank surrenders title to these bonds, which the Treasurer holds in trust primarily for the purpose of securing the redemption of the bank's circulation. The Comptroller gives the depositing bank power of attorney to receive and appropriate to its own use the interest on the deposited bonds, but this power becomes inoperative whenever the bank fails to redeem its circulating notes. Moreover, the interest is withheld if the bank fails (1) to pay the tax on the circulation, (2) to pay the penalty for failure to make reports required by the Comptroller of the Currency, (3) to pay instalments on account of capital stock, or (4) to make good an impairment of capital.

Upon the basis of these pledged bonds the depositing bank is authorized to receive from the Comptroller of the Currency an amount of circulating notes equal to the par value, but not greater than the market or cash value, of the bonds, and not in excess of the paid-in capital of the bank. Whenever the market value of any bonds thus deposited falls below the amount of the circulation issued for them, the Comptroller may demand and receive from the bank the amount of such depreciation, in other United States bonds at cash value or in money, to be deposited

with the Treasurer so long as the depreciation continues. If a bank desires to substitute United States bonds of a different issue for some already deposited, the Comptroller may permit such exchange, if in his opinion it can be made without prejudice to the United States. The Comptroller may direct the return to the depositing bank of any bonds, in sums not less than \$1,000, upon the surrender to him and upon the cancellation of a proportionate amount of its circulating notes, provided neither the market nor the par value of the remaining bonds deposited by the bank is less than the amount of notes not surrendered. To make withdrawals or transfer of deposited bonds for any purpose, the Comptroller and Treasurer insist upon the authority given by the board of directors under seal of the bank, together with the duplicate receipt given by the Treasurer at the time of deposit.

The Comptroller keeps a registry of all transfers or assignments of deposited bonds, and immediately advises the bank from whose account any transfer is made as to the kind, amount, and numerical designation of the bonds transferred. The Comptroller has access at all times to the books of the Treasurer to ascertain the correctness of any transfer or assignment of any deposited bonds, and the Treasurer has like access to the books of the Comptroller. The Comptroller also has access at all times to the bonds on deposit, to ascertain their amount and condition. Every depositing bank is required once or oftener in each fiscal year to examine and compare with the books of the Comptroller and the accounts of the bank the bonds pledged by the bank and, if no error is found, to present to the Treasurer a certificate setting forth the different kinds and amounts of the pledged bonds and stating that the same are in the possession and custody of the Treasurer at the date of the certificate. Such examination may be made by an officer or agent of the bank duly appointed in writing for that purpose. The bank is thus made directly responsible for ascertaining the actual presence and safety of these bonds.

The United States bonds which have the circulation privilege are as follows: the 4's of 1925, the 2 per cent consols of 1930, and the 2 per cent Panama Canal bonds. Of the \$793 million of eligible bonds, on June 30, 1919, there were on deposit to secure national bank notes, \$692 million, and to secure federal reserve bank notes, \$17 million. Of the 245 new banks chartered during the fiscal year ending June 30, 1919, only 65 deposited bonds for this purpose.

CHAPTER XVIII

NATIONAL BANK NOTES

Preparation of National Bank Notes

After the bonds have been deposited, the bank is entitled to receive from the Comptroller of the Currency circulating notes in blank, registered, and countersigned, equal to the par value of the bonds. The Comptroller has the plates engraved and the notes printed. The plates are made at the expense of the issuing bank, a plate with four notes on its face costing \$75, and with two notes \$50, but no charge is made for printing. The general expenses of the Bureau of the Currency are paid out of the proceeds from taxes on bank note circulation. To prevent the loss of the plates or the illegal issuing of notes, the plates are kept in the custody of the Secretary of the Treasury. The Comptroller is required to examine yearly the plates, dies, bed-pieces, and other material from which the notes are printed, and to file in his office a correct list of the same.

About 40 days are required to get out the first order of notes, and about 20 days for future orders, the difference in time being caused by the necessity of preparing plates in the first instance. The original order for circulation should, however, exceed the amount of circulation that can be taken out against the bonds deposited, as it is necessary for the Comptroller to have on hand enough notes to replace without delay any worn-out or mutilated notes sent in for redemption. Unless otherwise ordered, circulating notes are shipped by the Comptroller to the issuing bank by express at its own expense.

The notes when received by the bank are in large perforated sheets ready for the signature of the president, or vice-president, and of the cashier. It was formerly held that written signatures

on notes were necessary, but, while the Comptroller did not authorize or sanction any change in this respect, it gradually came about that no objection was made to printed or stamped signatures as distinguished from written signatures. Indeed, by an Act of 1920 engraved signatures were expressly permitted. As, however, all notes issued to or received by a bank are subject to redemption whether or not they are signed by the officers, the signature is not very important. After signing, the notes are cut and turned over to the paying teller who puts them into the cash of the bank.

Denominations and Character

The Act of June 3, 1864, provided for \$1, \$2, \$5, \$10, \$20, \$50, \$100, \$500, and \$1,000 notes, but not more than one-sixth part of the notes furnished to any bank was to be of smaller denomination than \$5, and after the resumption of specie payments no bank was to be furnished with notes smaller than \$5. The issuance of \$500 notes was discontinued in 1885, and of \$1,000 notes in 1884. Some notes of these early issues are still outstanding, but probably most of them are lost or held as souvenirs. The Act of March 4, 1900, limited the amount of \$5 notes issuable to any bank to one-third of its total issues. The rising price level and great business activity during the war occasioned a demand for small bills, and the passage of the Act of October 5, 1917, provided for the issue to any bank of \$1, \$2, \$5, \$10, \$20, \$50, and \$100 notes in such proportion as the bank might elect, but no bank may receive or have in circulation at any one time more than \$25,000 in notes of the denominations of \$1 and \$2. The Act of 1920 permitted again the issue of \$500 and \$1,000 notes. The notes state that they are secured by United States bonds or other securities, and express the promise of the issuing bank to pay on demand.

National bank notes are not a legal tender for private debts, but are receivable by the government in all payments except for

customs duties. The notes are also a legal tender in payments by the United States, except for interest on the public debt and in redemption of the national currency. Every national bank is required to accept at par the notes of every other national bank, but is forbidden to accept them as security for loans. The notes are redeemable in lawful money at the United States Treasury and at the bank of issue, and are also exchangeable at the Treasury for subsidiary silver and minor coins. Any notes not redeemed go to the profit of the United States.

The Redemption Fund

Immediately after a bank receives its first circulation from the Comptroller it is required to deposit with the Treasurer of the United States, as a redemption fund, a sum of lawful money equal to 5 per cent of its circulation. Remittances for credit to the 5 per cent fund may be made in several ways:

1. By check drawn on New York, payable to the Federal Reserve Bank of New York, collectible through the clearing house (of which the reserve bank is a member), forwarded to the reserve bank with instructions to deposit the amount to the credit of the 5 per cent fund and to forward the certificate of deposit to the Treasurer of the United States.

2. By the deposit of lawful money with any of the federal reserve banks or branch banks, on account of the 5 per cent fund. Banks not located in cities having a federal reserve bank or branch bank can request their correspondents to make the necessary deposits. The certificate of deposit must be forwarded immediately to the Treasurer of the United States, as no credit is given until he receives such certificate.

3. By sending direct to the Treasurer of the United States, Washington, D. C., the proper amount of lawful money. This package, if specifically marked "For the credit of the 5 per cent fund," will be transmitted by express companies at government rates. If the bank does not pay the express charges, the Treasurer

will pay them at government rates and deduct the amount from the bank's remittance.

The term "lawful money" includes every form of money which is endowed by law with the legal-tender quality. There is a diversity of opinion as to whether silver certificates can be used for this purpose.¹

The bank's contributions to the redemption fund cannot be counted as part of its reserve against deposits, nor can the bank count as reserve any amounts thus carried in excess of the minimum required; the redemption fund is not in the proper sense a bank reserve against notes, as the Comptroller uses it in redeeming for the most part only worn and mutilated notes presented to him; and it is not in any sense a reserve against deposits as it is not available for paying depositors. The amount of the fund is calculated on the amount of notes issued to the bank, no deduction being made even though all or part of such notes be lost, stolen, or put into circulation without the signature of the president, or vice-president, and of the cashier, or held in the vaults of the bank.

Method of Note Redemption

The notes must be presented to the Treasurer in sums of \$1,000 or any multiple thereof. Upon receipt they are sent to the National Bank Redemption Agency of the Treasurer's office, and are there sorted and redeemed. A bank sending notes should first have them assorted by denominations and enclosed in paper straps. No straps should contain more than 100 notes, and each package should be marked with the amount of its contents. A memorandum giving the amount of each denomination of notes, the total amount in the package, the address of the sending bank, and the disposition to be made of the proceeds, should be enclosed with each package and a letter of advice sent by mail. All pack-

¹ See Federal Reserve Bulletin, May 15, 1917, and Opinions of Attorney-Generals, Vol. 17, p. 123.

ages are sent to the "Treasurer of the United States, Washington, D. C.," "collect," under special government express rates.

The Treasurer on redeeming the notes charges them to the various issuing banks and notifies such banks on the first day of each month, or oftener, of the amount of their notes so redeemed and the corresponding reduction of their 5 per cent funds. When a bank receives such notification it must immediately deposit with the Treasurer lawful money equal to the amount of its notes redeemed, and keep the 5 per cent fund intact. If the amount redeemed does not exceed the 5 per cent fund of the bank, the notes fit for circulation are promptly forwarded to the issuing bank by express, and any notes unfit for circulation are delivered on the same day to the Comptroller of the Currency. If the bank's 5 per cent fund is overdrawn by such redemption, an amount of notes equal to the deficit is held by the Treasurer until the bank makes good the fund by the deposit of lawful money. As soon as this is done, all the fit notes are returned to the issuing bank and the remainder delivered to the Comptroller for destruction and for the issuance of new notes. Every bank is required by law to have in Washington a legal representative to witness the destruction of the mutilated currency, which is now done by maceration.

Withdrawal of Circulation

Should a bank reduce its circulation, either by depositing lawful money or by permitting notes to be redeemed by the Treasurer and destroyed and asking for no new notes to take their place, the amount of the 5 per cent fund may be correspondingly reduced. In such case the Treasurer will, upon receiving the proper advice, surrender any excess in the 5 per cent fund that may result from such destruction or reduction of notes; but he will not so release a portion of the 5 per cent fund until the details of the reduction of circulation are completed by depositing lawful money and withdrawing the bonds.

The bank must pay the charges for transportation and the

cost for assorting redeemed notes. At the end of each fiscal year, account having been kept of its expenses by the National Bank Redemption Agency, the several banks are assessed in proportion to the amount of their notes redeemed, and this sum is then charged to their 5 per cent funds respectively. If a bank deposits lawful money for the retirement of its circulation, it is assessed at the time it makes such deposit for the cost of transporting and redeeming the notes then outstanding, the assessment being equal to the average cost of the redemption of national bank notes during the preceding year. The rate charged to the national banks in 1915-1916 for redemption expenses was \$.817229 per \$1,000 redeemed.

Any bank desiring to withdraw all of its circulation, or any part of it, may do so by depositing with the Treasurer of the United States lawful money to an amount equal to the notes it wishes to retire. The Treasurer will then reassign the bonds to the bank which is withdrawing circulation, and will destroy the redeemed circulation. The retirement of circulation by depositing lawful money is limited to \$9,000,000 in any one calendar month.² In certain cases, however, this limitation does not apply: (1) when a bank reduces its capital stock to an amount below its outstanding circulation; (2) when a bank retires its circulation by surrendering the notes for cancellation without reissue, as in this case no deposit of lawful money is required; (3) when bonds are called for redemption by the Secretary of the Treasury and circulating notes are withdrawn in consequence thereof. The purpose of limitation on the rate of retirement of national bank notes is to prevent too sudden reduction in the volume of currency, with its train of undesirable consequences.

Effect of Liquidation

Within six months from the date of the vote to go into liquidation, the bank must deposit with the Treasurer of the United

² See Acts of July 12, 1882, March 4, 1907, and May 30, 1908.

States lawful money sufficient to redeem all outstanding notes. This deposit is made directly, or through a correspondent or agent, with the Treasurer at Washington. When the deposit is made and the bank has paid to the Treasurer all amounts due for taxes on circulation and for expenses of redeeming outstanding notes, its bonds on deposit will be surrendered to it. Thereafter the shareholders are discharged from all liability on the outstanding notes, and these notes are redeemable only at the Treasury. If the bank fails to take up the bonds within 30 days after the expiration of the time specified, the Comptroller has the power to sell them at public auction in New York and, after providing for the redemption of the outstanding notes and the necessary expenses of the sale, to pay over any balance remaining to the bank. It is made the duty of the Treasurer, the federal reserve banks, and designated depositories of the United States, to assort and return to the Treasury for redemption the notes of such national banks as have failed or gone into voluntary liquidation, and the Treasurer causes the redeemed notes of such banks to be destroyed and charged to the redemption accounts of the banks.

Effect of Failure to Redeem Upon Demand

Whenever a national bank fails to redeem in lawful money any of its circulating notes, upon demand of payment duly made at its place of business during the usual business hours, the holder may cause the notes placed in one package to be protested by a notary public, unless the president or cashier of the bank waives demand and notice of protest and makes, signs, and delivers to the holder making the demand an admission in writing stating the time of the demand, the amount demanded, and the fact of non-payment thereof. The notary public forwards such protest or admission to the Comptroller, who with the concurrence of the Secretary of the Treasury may then appoint a special agent, of whose appointment immediate notice is given to the bank, and

who proceeds at once to ascertain and report whether the bank has refused to pay its notes in lawful money when demanded. If, from such protest and the report of this agent, the Comptroller is satisfied that the bank has refused to redeem its notes and is in default, he declares, within 30 days, the deposited bonds forfeited to the United States. After notice has been sent to the defaulting bank it becomes unlawful for the bank to do any business except receive and safely keep money belonging to it and to deliver special deposits.

The holders of the notes of the defaulting bank are also immediately notified that the notes will be redeemed as presented at the Treasury. The Comptroller may then, at his discretion, either cancel an amount of bonds pledged by the bank equal at current market rates, not exceeding par, to the notes paid, or may cause so much of them as may be necessary to redeem its outstanding notes to be sold at public auction in New York City, after giving 30 days' notice of such sales to the bank. If the Comptroller deems it for the best interest of the United States, he may sell any of the bonds at private sale, but not for less than par value or market value thereof at the time of sale. If the proceeds of all the bonds of the bank when thus sold are insufficient to reimburse itself for the amount expended in redeeming the notes of the bank, the United States has a paramount lien upon all the bank's assets for the deficiency.

The Tax on National Bank Notes

National banks taking out circulation are subject to a tax on the average amount outstanding. This tax is payable semi-annually, and is at the rate of $\frac{1}{2}$ per cent per annum on such notes as are secured by 2 per cent bonds, and 1 per cent per annum on the notes secured by bonds bearing higher interest rates. The Treasurer, when levying the tax, takes as the basis the average amount of notes that the bank has had in circulation during the six months previous to the assessment date. This estimate must

be made by each bank and submitted, under the oath of the president or cashier, within 10 days from the first of January and 10 days from the first of July. If a bank fails to make a proper report on the average amount of circulation it has had outstanding for a period of six months, it is liable to a fine of \$200, and the tax which must be paid by the bank is then assessed upon the amount of notes that have been delivered by the Comptroller instead of upon the average amount in circulation. A bank calculates the average amount outstanding during a period by taking the amount it has outstanding each day for the period and dividing by the exact number of days. Should a bank not keep a daily record of outstanding notes, but obtain its averages from weekly statements, it adds together the amounts outstanding weekly and divides by the number of weeks. If there is any fraction of a week, the amount that should be added for each day of such fraction is one-seventh of the balance for the week immediately preceding the odd number of days.

A bank may pay the amount of tax assessed on its circulating notes to the Treasurer of the United States, or to a federal reserve bank or to national bank depositories. When payments are so made, certificates are issued in triplicate, the original being forwarded to the Secretary of the Treasury, the duplicate to the Treasurer, and the triplicate being held by the paying bank as a voucher. If there is not a depository convenient, payment may be made by draft on New York, payable through the clearing house, to the order of the federal reserve bank, or by direct remittance to the Treasurer in lawful money or national bank notes.

Public Advantages of National Bank Notes

By means of national bank notes several advantages are acquired by the public.

The national bank system was formed to provide a uniform bank note currency, and this purpose has been thoroughly realized. By conferring the printing, issue, and redemption of the

bank notes upon the Comptroller of the Currency, requiring the ample pledge of government bonds as security and requiring every national bank to accept the bank notes of every other national bank, the system provides a currency uniform in style, issue, redemption, security, and acceptability. The notes are national in a geographical sense, for they circulate freely at par in any part of the Union, however far from their issuing bank, and travel and domestic exchange are thereby greatly facilitated. Their uniformity also makes counterfeiting more easy to detect and cheaper to prosecute.

Again, the safety of national bank notes up to the present has been unquestioned. The security is twofold. Certain government bonds, among the best of the assets of the bank, are segregated and pledged specifically to secure the notes. The government guarantees the redemption of the notes, retaining a prior lien on all the assets of the issuing bank. The ultimate security is therefore the government credit, represented both in the bonds and in the guaranty of redemption, and only to a small degree does that security lie in the strength of the commercial banks. The 10 per cent margin of security required until 1900 between the par value of the bonds and the amount of notes issued to the banks, the present limitation that the amount of notes may not exceed the par value or, in the discretion of the Comptroller of the Currency, the market value of the bonds, and the confidence of the people in the financial omnipotence and fair dealing of our government, have sufficed to give the bank notes an unquestioned safety.

Secretary Chase and others holding the Hamiltonian idea of the political value of a public debt, believed that banks would have a more favorable attitude toward the government and would support it more willingly and fully if the value of their assets and the acceptability of their note issues depended upon the financial prosperity of the government—a theory which has since been borne out by the facts.

Banking Advantages of the National Bank Notes

The establishment of a safe and uniform bank note system has undoubtedly proved a direct benefit to banking by creating confidence in banking institutions. The National Banking Act stemmed the rising tide of hostile public opinion, which in its most radical phase demanded the suppression of all banks as a penalty and cure for the losses, disturbances, and inconveniences wrought under the then existing system.

Then, too, the banks derive an advantage from the fact that the national bank notes bear the name of the bank and the adjective "national," which serves to advertise the bank among noteholders. An advertising advantage is also realized from having an amount of United States bonds in the bank's statement, since it suggests conservative management and the possession of a reliable secondary reserve. In addition, the ownership of government bonds by the banks and the provision for central redemption of notes open to the banks avenues for cultivating friendly relations with the United States Treasury.

The chief advantage to the banks is sometimes presumed to be the gaining of profits from the note issue privilege. It is commonly alleged that banks make a "double profit"—the interest on the pledged bonds, and the interest on the loans of notes. The extra profit from the interest on the bonds is not large, however, since the rate of interest on most of the bonds bearing the circulation privilege is now only 2 per cent, and this percentage is reduced by several factors. If the bonds sell at a premium, more is paid for a bond than the sum of the notes which may be issued on it, since the notes may not exceed the par value of the bond. Moreover, the bank must maintain a 5 per cent redemption fund with the Treasurer and this may not be regarded as reserve and does not earn interest. In addition, the circulating notes are taxed 1 or $\frac{1}{2}$ per cent per year, and the expense of preparing plates, transporting, issuing and redeeming notes, examining the bonds and plates annually, and witnessing the de-

struction of worn-out notes, must be deducted from the gross profit. Furthermore, if the bonds are bought above par and will be redeemed at par, a sinking fund must be maintained. And, finally, the full volume of notes issued to the bank cannot be kept continuously outstanding by means of loans. After making these many deductions, the net profit from the circulation privilege is small.

The profit is further affected by money rates. In the case of a purchase of bonds at par, the average rate for money does not affect the additional profit derived from taking out circulation, as the amount of notes received is exactly the same as the money invested in the bonds. With bonds purchased at a premium, it is more profitable to take out circulation in a low money market than in a high, since the notes received are less in amount than the price paid for the bonds, and the bank will therefore be able to loan an amount only equal to the par value of the bonds. In a low money market this loss of interest is less than in a high market. Hence, in case of bonds bought at a premium the profits are less in a high money market than in a low money market.

Method of Calculating Profit on Note Circulation

Profit on a national bank's circulation may be thus calculated:

Date of calculation, March 1, 1910.	
Issue of bonds purchased, United States registered 2% bonds of 1930.	
Price of bonds (101 and interest), \$101,000.	
Par value of bonds, \$100,000.	
Money worth on the market, 6%.	
Income from bonds per year.....	\$2,000
Income from circulation (\$100,000 less \$5,000 redemption fund) loaned at 6%.....	<u>5,700</u>
Total gross income.....	\$7,700
Deductions:	
Tax on circulation.....	\$500
Sinking fund to retire premium, set aside each year....	26
Expenses for plates, expressage, etc.....	<u>63</u>
	<u>589</u>

Net income from circulation.....	\$7,111
Net income from loaning \$101,000 (net cost of bonds purchased) at 6%.....	6,060
Increased income from circulation over loaning cost of bonds direct.....	1,051
Percentage of increased profit on investment.....	1.04%

C. F. Childs and Company, specialists in government bonds, publish the following table of the profits from the note issue privilege under varying conditions of bonds, money rates, and purchase price:

TABLE SHOWING RELATIVE ANNUAL PROFIT AT DIFFERENT PRICES AND MONEY RATES ON A BASIS OF A PURCHASE OF \$100,000 BONDS AS OF JUNE 1, 1919

Price of Bonds	Money at 8%	Money at 7%	Money at 6%	Money at 5%
Consol 2's at*				
101	\$ 957	\$1,017	\$1,076	\$1,135
100¾	977	1,034	1,092	1,148
100½	997	1,052	1,107	1,160
100¼	1,017	1,070	1,122	1,173
100	1,037	1,087	1,137	1,185
99¾**	1,057	1,105	1,152	1,198
99½	1,077	1,122	1,167	1,212
99¼	1,097	1,140	1,182	1,224†
99	1,117	1,157	1,197	1,237
98¾	1,137	1,175	1,212	1,250
98½	1,157	1,192	1,227	1,263
98¼	1,177	1,210	1,242	1,275
98	1,197	1,227	1,257	1,288
97¾	1,217	1,245	1,272	1,300
97½	1,237	1,262	1,288	1,313
97¼	1,257	1,280	1,302	1,326
97	1,277	1,297	1,318	1,338

Old 4's at‡

108 ½	\$ 677	\$ 778	\$ 878	\$ 977
108 ¼	732	832	930	1,028
108	787	885	981	1,078
107 ¾	842	938	1,033	1,128
107 ½	896	991	1,085	1,179
107 ¼	951	1,044	1,137	1,179
107	1,006	1,098	1,189	1,229†
106 ¾	1,060	1,151	1,240	1,329
106 ½	1,115	1,204	1,292	1,380
106 ¼	1,170	1,257	1,344	1,430
106	1,224	1,311	1,396	1,480
105 ¾	1,279	1,364	1,447	1,530
105 ½	1,334	1,417	1,499	1,581
105 ¼	1,389	1,470	1,551	1,631
105	1,443	1,523	1,551	1,631
104 ¾	1,498	1,576	1,655	1,731
104 ½	1,552	1,629	1,707	1,782

* Childs and Company's calculation ignores the factor of amortization of premium and accumulation of discount from value at maturity, the term assumed being 100 years.

** During and subsequent to the drafting of the Federal Reserve Act the market value for the 2 per cent bonds has continued, with one brief exception, to be quoted at discount prices. The Secretary of the Treasury in consequence has ruled that no additional deposit of bonds is necessary or will be called for to offset nominal depreciation in the value of the bond collateral. The 5 per cent redemption fund held at the Treasury Department against all outstanding circulation, coupled with the bank's responsibility and solvency, are regarded as adequate margin to cover any probable depreciation in price of the bonds. The result of this ruling is to make the note issue privilege increasingly profitable as the bonds depreciate below par.

† In a 5 per cent money market the net profit from Consol 2's costing 99 ¼ and Old 4's costing 107 is virtually equal.

‡ Assuming maturity 1925.

It thus appears that the profit is lowest when the premium is highest; that at any market price it is higher when the market rate of interest is lowest; that the profits on the 2's may be as great as on the 4's, since the purchase price of the bonds may equalize the earnings. Roughly speaking, in the light of the prevailing prices of these bonds, the circulation privilege adds 1.5 per cent to the earnings of the bond and therefore gives the bond an exceptional value in the hands of the national banks; any other buyer, capitalizing the earnings which he would receive alone as interest, could afford to pay less than par. The bonds

have an artificial value, part of it being the capitalized value of the monopoly note issue privilege; the recent popular notion that the government could borrow freely at 2 per cent is beside the point.

Disadvantages of National Bank Notes

National bank notes have several disadvantages.

For one thing, the profits to the national banks from the bank note privilege are so small and the operations of issue, withdrawal, and redemption so troublesome, that many national banks make no use of their privilege in this respect or only a partial use.

Again, the volume of circulating notes is made dependent upon the price of bonds, that is, upon the speculative and investment market, which may or may not coincide with the needs of the commercial money market. If the financial market is strong and bonds rise to premium standard, the profit from the circulation privilege declines; and if the commercial money rate is also high at such times, the profit is still lower. There would seem, therefore, to be a sort of perverse elasticity to the circulation. It is difficult to show this statistically because the number of banks and the capitalization of banks are varying at the same time that the prices of the bonds and the amount of bonds deposited to secure circulation are varying.

A further disadvantage is the fact that the volume of national bank notes is made dependent upon the government debt. The expansion of the debt may cause undesirable expansions of the circulation, though the government has lately prevented this by denying new bond issues the circulation privilege. On the other hand, if the government pays its debt, the volume of bank notes must contract; if, as between 1880 and 1891, the Treasury goes on the open market and buys bonds, the price is driven to a point of high premium, eliminating the profits on the circulation. Between the dates mentioned the volume of bank notes declined

51 per cent (see Table Showing Effect of Debt Payment on Circulation) and this despite the fact that that was a decade of unparalleled growth in population and wealth and business activity, and when the need for an increasing currency was peculiarly felt because gold production was not keeping up with the world's needs. This decrease was due to the payment of more than half the government debt within those years. During this period, however, the number of national banks was fast increasing, so that each bank was shorn to its minimum amount of required circulation.

TABLE SHOWING EFFECT OF DEBT PAYMENT
ON VOLUME OF CIRCULATION

	National Bank Notes Outstanding (In millions)	Price of 4's of 1907 (Range)	Government Debt (In millions)
1879			\$1,996
1880	\$344.5	103-113
1881	355.0	112-118
1882	358.7	117-121
1883	356.0	118-125
1884	339.5	118-124
1885	318.5	121-124
1886	311.7	123-129
1887	279.2	124-129
1888	211.4	126-129
1890	185.9	122-126	891
			\$1,105 (Debt paid)

One other bad feature of this dependence on government debt is that there is no physical limit to the inflation of notes. If the notes were made dependent on a reserve of gold they could be increased only by some multiple of that reserve, and the reserve could not be increased largely or suddenly since the gold must first be dug from the earth. On the other hand, if the notes were

made dependent upon commercial paper they would vary with business need. But the inflation of notes based on debt may come at the very times when the currency is being inflated by gold, and may therefore accelerate the rise of the price level unduly. Such was the case after 1900.

Another disadvantage of national bank notes is that the volume of circulation is at the caprice of the legislature. By permitting banks to organize at smaller capitalization and requiring them to buy fewer bonds, and by lowering the tax on circulation, Congress caused a sudden and tremendous expansion in the bank note circulation between 1900 and 1914. National banks of small size were organized in great numbers, particularly in the South and West, and generally in rural districts. It is true that these were the proper regions for the circulation of bank notes, and the increase occurred during a period of rapid industrial expansion; but the increase was a factor in unduly accelerating the rise of prices at the time. (See the table, page 234, for the periods of rapid increase and decrease of our bank note currency.)

The fact that national bank notes have a 5 per cent redemption fund but no strictly reserve fund held against them, is an additional disadvantage. Since they remain in circulation indefinitely, the issuing bank usually minimizes or disregards the liability of their presentation for redemption and keeps on hand little, if any, gold for this purpose. But the state banks, trust companies, savings and private banks regard the notes as reserve, in accordance with the law, and base extensions of deposit credit upon them. As a result there is a pyramiding of credit, which extends the weaknesses of the bank notes to the deposits. It was still more dangerous when national banks sometimes, contrary to law, counted the bank notes in their tills as part of their reserve. At present the legal reserve of all member banks of the federal reserve system consists wholly of credits with the federal reserve bank.

Inelasticity

The chief criticism of national bank notes, however, is their inelasticity—the quantity of notes does not bear a direct ratio to the volume of business done. Bank notes should expand and contract in amount automatically with the flow and ebb of business, otherwise there will be a plethora of money in dull times and a dearth of it in good times, fostering high prices and speculation in dull seasons and depressing the periods of business activity. The full profit from the note issue privilege can be earned only if the notes are constantly in circulation; a bank therefore takes out only such circulation as it finds by experience it can keep circulating nearly all the time. The profit on the circulation is so small that it has been difficult to get banks to take out enough to provide for periods of great business activity. On the other hand, the expense incident to the retirement of bank notes has discouraged banks from retiring them whenever business slackens.

The law allows the bank to pay out over its counter the notes of other banks, and in most states to consider national bank notes as legal reserve money. The law also compels every national bank to accept at par the notes of every other bank. The results of these facts are:

1. The volume of national bank notes changes relatively little from season to season and from year to year.
2. In dull times the notes drift into the cash of the national and state banks and are paid out over the counter of non-issuing banks, and also drift into the reserves of state banks, and remain out of circulation permanently.
3. The motive for presenting the notes for redemption is minimized, so that most of them are presented only when they become unfit for redemption.
4. When business becomes more active, the volume of cash transactions increases as well as the volume of credit transactions, but, since the bank notes are not increased, the extra money

required is drawn from the bank reserves or till money by the public withdrawing from the banks more money than is deposited; this results in "tight money," high interest rates, and contracted accommodation at a time when just the opposites are needed; the inelasticity of the bank notes therefore not only throws upon deposit currency the burden of providing elasticity of credit, but also tends to defeat the natural elasticity of that deposit currency.

5. The want of a bank note issue which can be expanded and contracted locally, with the seasonal needs for variation in the currency, makes necessary the transportation of coin, greenbacks, or certificates from one geographical area to another—an expensive, cumbersome, speculative, and unsatisfactory operation. Accordingly the relief of currency deficiencies is always likely to be tardy; and as soon as the business activity that occasioned the shipment subsides, the currency flows back to money centers, causing low money rates and fostering speculation on the stock and produce exchanges:

After 1900 and up to 1913 the volume of bank notes expanded almost as fast as did business transactions and deposit currency, but, as shown above, this expansion was due to the extension of national banks in new areas which either had been without banks or had depended upon deposit currency. In the old business areas the supply of bank notes did not expand with business needs. The relative growth and elasticity of bank notes and individual deposits in recent years are indicated in the table on page 347 made from the Comptroller's calls:

Other Disadvantages

Besides the disadvantages mentioned above, the national bank note system has this objection—that it failed to provide for an emergency circulation. This defect was seriously realized in the panic of 1907, and in 1908 the Aldrich-Vreeland Act was passed in order to provide a temporary arrangement for needed emergency

TABLE SHOWING THE RELATIVE VOLUMES, RATES OF GROWTH, AND ELASTICITY OF THE NATIONAL BANK NOTES AND THE DEPOSITS OF NATIONAL BANKS

(In millions)

Call	Individual Deposits	National Bank Notes Outstanding	Call	Individual Deposits	National Bank Notes Outstanding
1903			1912		
2/6	\$3,159.5	\$335.2	2/20	\$ 5,630.6	\$ 704.2
4/9	3,168.3	358.1	4/18	5,712.1	707.0
6/9	3,201.0	359.3	6/14	5,825.5	703.7
9/9	3,156.3	375.0	9/4	5,891.7	713.8
11/17	3,176.8	376.2	11/26	5,944.6	721.5
1904			1913		
1/22	3,300.6	381.0	2/4	5,985.4	717.5
3/28	3,254.5	385.9	4/4	5,968.8	719.0
6/9	3,312.4	399.6	6/4	5,953.5	722.1
9/6	3,458.2	411.2	8/9	5,761.3	724.5
11/10	3,707.7	419.1	10/21	6,051.6	727.0
1905			1914		
1/11	3,612.5	424.3	1/13	6,072.0	725.3
3/14	3,777.5	431.0	3/4	6,111.3	720.6
5/29	3,783.7	445.5	6/30	6,268.6	722.5
8/25	3,820.7	469.0	9/12	6,139.0	918.2
11/9	3,989.5	485.5	10/31	6,078.8	1,018.1
1906			12/31	6,346.3	848.8
1/29	4,088.4	498.2	1915		
4/6	3,978.5	505.5	1/4	6,348.8	746.5
6/18	4,055.6	510.9	5/1	6,661.5	727.7
9/4	4,199.3	518.0	6/23	6,611.2	722.7
11/12	4,289.8	537.0	9/2	6,762.1	718.4
1907			11/10	7,386.1	713.4
1/26	4,115.6	545.5	12/31	7,641.2	713.3
3/22	4,269.5	543.3	1916		
5/20	4,322.9	547.9	3/7	7,716.3	695.8
8/22	4,319.0	551.9	5/1	8,135.9	682.2
12/3	4,176.7	601.8	6/30	8,142.9	676.1
1908			9/12	8,445.5	674.1
2/14	4,105.8	627.6	11/17	9,139.1	665.2
5/14	4,312.7	614.1	12/27	9,003.0	666.4
7/15	4,374.6	613.7	1917		
9/23	4,548.1	613.7	3/5	9,273.8	661.1
11/27	4,720.3	599.3	5/1	9,606.4	656.1
1909			6/20	9,521.6	660.4
2/5	4,699.7	615.3	9/11	9,975.3	665.6
4/28	4,826.1	636.4	11/20	10,338.8	669.7
6/30	4,898.6	631.3	11/31	10,734.6	674.3
9/1	5,009.9	658.0	1918		
11/16	5,120.4	668.4	3/4	10,454.8	672.2
1910			5/10	10,437.4	680.4
1/31	5,190.8	667.5	6/29	10,181.7	681.6
3/29	5,227.9	669.2	8/31	10,493.2	674.2
6/30	5,287.2	675.6	11/1	11,013.3	675.5
9/1	5,145.7	674.8	12/31	11,934.4	676.8
11/10	5,304.8	680.4	1919		
1911			3/4	11,211.0	673.9
1/7	5,113.2	684.1	5/12	11,832.7	676.9
3/7	5,304.6	680.7	6/30	11,891.1	677.2
6/7	5,478.0	681.7	9/12	12,672.5	681.6
9/1	5,490.0	697.0			
12/5	5,536.0	702.6			

circulation until a new banking system could be devised. The nature of this act and the use made of it in 1914-1915 have been already described.

A final disadvantage of the national bank note system arose from the fact that difficulty was always experienced in getting a uniform development of the national banks as among the states and, therefore, in satisfying the needs of the various sections of the country for bank notes. The Act of 1865 apportioned the notes on the basis of population, banking capital, and resources and business of the states. In 1870 the same provisions were made for the apportionment of the increase of \$54,000,000 circulation. This act went further, however, and provided for the reduction of bank notes of banks in those states which had a circulation in excess of their due proportion according to the new census, the reduction beginning with the larger banks in such states. The total reduction was limited to \$25,000,000, and the circulation thus withdrawn was to be apportioned among banks in those states which had less than their due proportion. Of this reapportioned circulation the banks in the older sections of the country got more than those in the newer sections in the South and West, although the need in the newer sections was probably greater, since these sections were agricultural, more sparsely settled—and therefore less fitted for deposit currency—and had fewer banks. The newer sections, moreover, did not take full advantage of their opportunity to get additional circulation as provided by the Act of 1870.

This whole scheme of equalization was set aside by the Act of 1875, which allowed banks to issue notes to any amount, subject to the general provision governing the purchase and deposit of bonds. The result has been that national banks, because of limitations on capitalization, loans on real estate, etc., have been less able to extend into and adapt themselves to new and agricultural country than have state banks, and therefore

these areas have been made dependent upon deposit currency. This disadvantage, however, was somewhat alleviated by the Act of 1900, and now a goodly fraction of the national bank notes are issued by country banks.

CHAPTER XIX

FEDERAL RESERVE NOTES

Issue of Federal Reserve Notes

One of the chief objects of the Federal Reserve Act was to replace the unsatisfactory national bank notes with a bank note currency that should be controllable and elastic. The provisions of the act for retiring the national bank notes, creating a market for the 2 per cent bonds, and converting these 2 per cent bonds into 3 per cent bonds without the circulation privilege, have been described in Chapter XVII.

Federal reserve notes are issued at the discretion of the Federal Reserve Board to the federal reserve agents for the purpose of making advances to the respective federal reserve banks. By provision of the original Act of 1913 and the amendment of 1916 a reserve bank may make application to the local federal reserve agent for such amount of federal reserve notes as it may require. The application must be accompanied with a tender to the agent of collateral in amount equal to the notes applied for, the offered collateral to consist of notes, drafts, bills of exchange or acceptances rediscounted for a member bank of its district, bills of exchange indorsed by a member bank of any federal reserve district and purchased in the open market, or bankers' acceptances purchased in the open market. All issues and withdrawals of federal reserve notes to and by the reserve bank to which the federal reserve agent is accredited must be reported by the agent to the Federal Reserve Board, and the board may at any time require from a federal reserve bank additional collateral to protect the notes issued to it.

Any federal reserve bank may, at its discretion, withdraw collateral deposited with the federal reserve agent for the protec-

tion of its federal reserve notes, but must at the same time substitute therefor, with the approval of the federal reserve agent acting under regulations prescribed by the board, other similar collateral of equal amount.

When the original pledge becomes collectible it is necessary that the paper be in the hands of the bank for collection, and therefore it is necessary to withdraw the collateral about 10 days before its maturity. Instead of requiring the federal reserve bank to pledge other paper or gold or lawful money as substitutes—operations which would reduce the bank's note-issuing capacity—the Federal Reserve Board has ruled that the federal reserve agent may appoint the federal reserve bank as his collecting agent, and the reserve bank need not make the substitutions of paper, gold, or lawful money until the actual date when the original paper pledged to secure the notes falls due. The federal reserve agents are therefore authorized to turn over maturing paper to their respective federal reserve banks for collection, upon the execution by the bank of a receipt reciting the fact that the papers are taken for collection only, settlement to be made with the federal reserve agent in gold or lawful money on the dates when the papers mature, unless other eligible paper has been already substituted for the maturing paper. Such notes or bills should be indorsed to the federal reserve bank "for collection for account of the federal reserve agent," or a rider should be attached to them showing that they are delivered to the federal reserve bank for collection, in order that any banks used by the federal reserve bank in making the collection may have notice of the transaction.

In order that an adequate stock of notes may be on hand in an emergency for any federal reserve bank needing them, the Federal Reserve Board has provided for the printing of a sufficient supply of notes and turned them over to the federal reserve agents and federal reserve banks, in their joint custody and in trust for the board.

Methods of Redemption and Retirement

Any federal reserve bank may at any time reduce its liability for outstanding federal reserve notes by depositing with the federal reserve agent its federal reserve notes themselves, gold, gold certificates, or other lawful money. Federal reserve notes so deposited may not be reissued, except upon compliance with the conditions of an original issue. The federal reserve agent must hold the gold, gold certificates, or lawful money exclusively for exchange for the outstanding federal reserve notes. Upon request of the Secretary of the Treasury the Federal Reserve Board must require the federal reserve agent to transmit to the Treasury of the United States so much of this gold as may be needed for the exclusive purpose of redeeming these outstanding notes.

This method of retirement at first resulted in impounding gold and gold certificates in the hands of the federal reserve agents and substituting in the circulating media of the country federal reserve notes for the gold and gold certificates. On the basis of pledges of eligible commercial paper—bought in the open market or received as rediscounts—federal reserve notes were issued by the federal reserve agent to the reserve bank; at maturity of this paper the bank would recover it with gold, gold certificates, and lawful money, leaving the federal reserve notes in circulation. This policy was deliberately pursued by the Federal Reserve Bank of New York, which retained the gold and gold certificates that came into its hands, and paid out its federal reserve notes. The gold and gold certificates thus acquired it used to recover commercial paper pledged with the federal reserve agent, and did not present its notes for redemption. This was a roundabout method of issuing federal reserve notes for gold, the direct issuance of notes for gold being prohibited by the Federal Reserve Act as originally passed.

The purpose of the New York bank in so doing was to concentrate the gold reserves of the country in the federal reserve system, and put them behind the federal reserve notes rather than behind

the gold certificates. Since the gold certificate is but a warehouse receipt for the gold itself, the impounding of the receipts was equivalent to the impounding of the gold, and both may be counted as reserves.

Effect of Gold Reserve Concentration

Several important results flowed from this operation under the original provisions of the Act:

1. The federal reserve notes became themselves practically gold certificates, the federal reserve agent holding in gold about 90 per cent of the face value of the outstanding notes as security against them.

2. The federal reserve notes, instead of being quickly returned after issue and redeemed, were kept in circulation; the seasonal variations which it was expected would characterize the volume of federal reserve notes were less evident, and the volume kept increasing as fast as the gold and gold certificates in circulation decreased.

3. The federal reserve banks were put in a position to extend to the member banks quantities of federal reserve notes, in exchange for deposits of checks and the deposit of gold or gold certificates, as well as through rediscounting, which was probably the method contemplated by the Federal Reserve Act.

4. The federal reserve bank was given perfect facilities for effecting, according to the requirements of the bank, an interchange between the gold and rediscount paper held by the agent.

5. The federal reserve bank had sufficient stock of gold to meet the requirements of any member bank or other federal reserve bank, should such bank at any time seek credit in order to withdraw gold for foreign or domestic use. At the same time the increased circulation of its federal reserve notes did not impair the rediscount power of the federal reserve bank, since the gold to which the bank had access increased faster than the volume of its rediscounts. In fact its rediscount capacity was

increased; if there were an unusual demand for redemptions and a corresponding reduction of notes in circulation, and a contraction of the currency threatened, the reserve banks might grant rediscounts more freely, without check from the reserve requirement until the reserve had been reduced to 40 per cent of the note and 35 per cent of the deposit liabilities. By the concentration of reserves the ultimate power of credit expansion is very greatly increased.

6. The defensive power of the banking system was increased as against the credit contraction that needs must follow the exportation of gold; for if the gold had been withdrawn from the federal reserve bank by the presentation of notes for redemption it would have reduced very little the country's supply of credit, since the credit based on the gold scarcely exceeded the amount of the gold; but if the gold had been withdrawn from member banks the credit contraction would have been great, since each dollar of gold in the member banks supported a superstructure of many dollars of credit. This defensive power, however, has recently been lessened through the greater expansion of federal reserve notes than of the reserve itself.

Direct Issue of Notes for Gold

On June 21, 1917, the Federal Reserve Act was amended to permit the direct issue, by the federal reserve agent to the federal reserve bank, of federal reserve notes for gold and gold certificates. By this amendment the federal reserve bank need no longer resort to the roundabout method described above. Gold and gold certificates were thereby added to the list of collateral receivable by the federal reserve agent as security for notes, and it was provided that, when the federal reserve agent holds gold or gold certificates as collateral for federal reserve notes issued to the bank, such gold or gold certificates are to be counted as part of the gold reserve which the bank is required to maintain against its outstanding federal reserve notes. The 40 per cent gold re-

serve required by the Act of 1913 was not intended as collateral but as a protection against undue and excessive issues; it was a requirement in addition to that of the 100 per cent deposit of the commercial paper pledged. Today, however, the gold and the paper together make no more than 100 per cent—that is, 40 per cent gold and 60 per cent eligible paper—and the lending power of the banks is therefore increased.

Notes may now be issued against commercial paper or gold, or both, so long as every federal reserve note is covered by 100 per cent commercial paper or gold, and so long as there is not less than 40 per cent gold reserve against all notes outstanding. Arguments for the direct issue of federal reserve notes for gold are:

1. It is the common practice of Europe. In every country of Europe gold importations go directly into the central bank in exchange for its notes, just as in this country they go into the Treasury in exchange for gold certificates.

2. Gold that backs gold certificates supports only its face value in credit, but gold used as reserve for federal reserve notes may support $2\frac{1}{2}$ times its face value in credit, and in emergencies even a greater multiple. The gold stock of the country is, therefore, more efficient if it is in the custody of the federal reserve bank (or federal reserve agent) than if it is in circulation, or is in the Treasury backing gold certificates which are in circulation. When the gold for the country is concentrated in its reserves, the federal reserve system will be strongest and the federal reserve notes will answer all the purposes of gold certificates.

3. When exportation of gold is necessary, the central bank is able to supply it with the least possible disturbance to financial conditions. For example, if the \$1.5 billion of gold certificates were concentrated in the federal reserve banks, these banks would be able, if necessary, to release \$600 million of gold for export and still have a 60 per cent reserve against their outstanding notes; and these changes might take place without affecting the amount of currency in circulation or disturbing domestic credits.

4. The direct issue of federal reserve notes for gold or gold certificates is the better method of substituting reserve notes for gold or gold certificates in circulation, since it permits the direct accomplishment of what was formerly done indirectly.

Amendment Providing for Direct Issue

The effects of the amendment of June 21, 1917, and the use made of the privileges conferred by it are indicated in the following statistical statement covering the month before and the month after that date:

TABLE SHOWING THE EFFECTS OF THE AMENDMENT OF JUNE 21, 1917, ON THE COLLATERAL BEHIND THE FEDERAL RESERVE NOTES

(In millions)

Date 1917	FEDERAL RESERVE BANK OF NEW YORK			FEDERAL RESERVE SYSTEM			
	Federal Reserve Notes Issued by Federal Reserve Agent (Net)	Cover Held by Agent		Total Federal Reserve Notes Issued by Agents (Net)	Cover Held by Agents		
		Gold	Paper		Gold	Paper	
						Minimum Required	Actual Amount
May 18....	\$205.2	\$205.2	\$478.9	\$448.3	\$ 30.6	\$ 32.4
25....	208.6	208.6	488.1	456.6	31.5	32.7
June 1....	212.8	212.8	499.8	466.9	32.9	34.4
8....	215.0	215.0	512.5	475.2	37.3	37.0
15....	219.9	194.9	\$ 25.0	528.0	460.0	68.0	69.2
22....	223.7	123.7	100.0	540.0	390.8	149.2	153.1
29....	229.3	139.3	90.0	550.5	402.6	147.9	153.4
July 6....	233.0	148.0	85.0	570.7	413.7	157.0	162.7
13....	238.3	161.8	76.5	579.9	428.3	151.6	158.5
20....	238.4	162.0	76.5	583.9	423.9	160.0	168.2

By the amendment the federal reserve bank may count the gold held with its federal reserve agent as part of the required reserve against its outstanding federal reserve notes, and may substitute commercial paper for the gold to any extent desired, provided that the gold remaining in the hands of the agent or specially

segregated as a reserve against notes in the vaults of the bank itself does not fall below 40 per cent of the notes outstanding. During the strain that existed in the latter part of June 1917, due to the Liberty Loan payments and the tax and other payments at the end of the fiscal quarter, the Federal Reserve Bank of New York, which had carried 100 per cent gold and no commercial paper with its federal reserve agent, now carried \$100,000,000 of paper to the federal reserve agent and withdrew a like amount of gold to strengthen its gold position with respect to deposits. As a result, the per cent gold reserve against notes declined. Since June 21, 1917, however, the matter of the per cent gold reserve against notes considered by themselves is wholly without significance, for the reserve bank can at any time shift notes or gold from the deposit-banking side to the note-issuing side, or vice versa. The reserve banks, following the recommendation of the board, endeavor to keep an equable distribution of funds held by the banks and the reserve agents, so as to be able to show in their reports approximately equal percentages of reserves against federal reserve notes and against deposits.

Reserves of Federal Reserve Banks

Before June 21, 1917, there was, after the manner of the Bank of England, a severe separation of the gold held against notes (100 per cent or nearly that amount being carried with the federal reserve agent, and at least 40 per cent being carried in the bank itself) from the gold held (wholly in the bank itself) against deposits. The amendment made the system more logical by providing a means of combining or interchanging the reserves against notes and deposits. Gold which was lodged with the federal reserve agent, and which was the basis of 100 per cent credit at most, now became the basis for 250 per cent credit, or even more if the reserve requirements were suspended or the tax on deficient reserves was paid.

During the period 1917-1918 the gold in the federal reserve

banks was greatly increased by several factors. For one thing the Federal Reserve Act had provided for a gradual transfer of the deposits of member banks from their correspondents to the federal reserve banks, and the amendment of June 21, 1917, provided for the immediate completion of that process. Again, the state banks and trust companies were empowered by law in many states to carry their reserves, in whole or part, to the federal reserve banks; all institutions of this kind which joined the system were automatically forced to carry their full reserve with the federal reserve banks, and many others found it expedient to do so to avail themselves of the clearing and collection facilities of the federal reserve system. Then, too, the banks of the country were importuned to concentrate their reserves in the federal reserve banks and thus strengthen the system for the strains of war financing. Moreover, the reserve banks have issued notes for gold at every opportunity, and have advised against withdrawals of gold. Finally, heavy importations of gold during 1915-1917, and the prohibition or regulation of gold exportations during the war, have favored the accumulation of large specie holdings.

The amendment of June 21, 1917, also provided for the joint custody and control of gold, lawful money, and federal reserve notes heretofore held by the federal reserve agents alone. These funds are now kept in safes with two locks or combinations, one in control of the federal reserve agent and his representative, the other in control of the officers of the reserve bank, and a joint record and periodic audit of accounts are made. The amendment made no provision for the joint custody of the commercial paper and other eligible securities pledged as collateral for federal reserve notes, but the board has recommended the same treatment for these also.

The Federal Reserve Act provides that a gold reserve of not less than 40 per cent must be maintained by the federal reserve bank against its federal reserve notes in actual circulation and

not offset by gold or lawful money deposited with the federal reserve agent. The federal reserve notes are redeemable in gold, on demand, at the United States Treasury in Washington, or in gold or lawful money at any federal reserve bank. The board must require each federal reserve bank to maintain on deposit in the Treasury a sum in gold sufficient, in the judgment of the Secretary of the Treasury, for the redemption of the federal reserve notes issued to each bank, but in no event less than 5 per cent of the amount of these notes. This redemption fund may be counted as part of the 40 per cent reserve required against the notes.

Tax on Deficiency of Reserves

To provide against extreme emergencies, provision is made for the increase of federal reserve notes. The Federal Reserve Board may suspend, for a period not exceeding 30 days (though it may from time to time renew such suspension, for periods not exceeding 15 days) any reserve requirement of the Federal Reserve Act, provided it assesses at the same time a certain tax on the notes. That is, notes may be issued reducing the reserve below the required 40 per cent on the condition that the Federal Reserve Board assesses a graduated tax of not more than 1 per cent per annum upon the deficiency of the reserve, until the reserve is reduced to 32½ per cent, and thereafter a graduated tax of not less than 1½ per cent on each additional 2½ per cent deficiency or fraction thereof. The following table indicates the tax rates if the board fixes the maximum 1 per cent and the minimum 1½ per cent as just described:

Reserves	Tax Rate
Below 40.0% to 32.5%	1.0%
32.5 " 30.0	2.5
30.0 " 27.5	4.0
27.5 " 25.0	5.5
25.0 " 22.5	7.0
22.5 " 20.0	8.5

20.0	to	17.5	10.0
17.5	"	15.0	11.5
15.0	"	12.5	13.0
12.5	"	10.0	14.5
10.0	"	7.5	16.0
17.5	"	5.0	17.5
5.0	"	2.5	19.0
2.5	"	0	20.5

This indeed provides an elastic limit and makes possible the use of reserves for defensive purposes, but the tax rates soon become prohibitive. It is further provided that the federal reserve bank must add an amount equal to these tax rates to its rates of interest and discount. The discount rate, therefore, will also soon become prohibitive. This elastic limit is less awkward of initiation than the English plan of suspending the reserve requirement by act of Parliament. As compared with the German 5 per cent flat tax rate on the excess issue, the American plan is less severe at first but more severe ultimately.

Other Devices for Obviating Deficiencies of Reserves

The paragraph of the Federal Reserve Act prescribing the conditions when the reserve requirement may be suspended, and the penalties for violation, is very loosely drawn. It provides a graduated tax for deficiencies of reserves against notes, but not against deposits. Formerly, in order to determine whether a deficiency of reserve existed, the practice of the federal reserve banks had been to subtract 35 per cent of the deposits from the existing reserve and see whether the amount remaining equaled 40 per cent of the federal reserve notes outstanding. But in February, 1920, when this method showed that actual deficiencies existed, the method was changed, so that now 40 per cent of the federal reserve notes is subtracted from the actual reserves, and the deficiency or excess is shown with respect to deposits. By this change in method of calculation, therefore, the provisions of the

law which aimed at checking inflation of the credit of reserve banks through the graduated tax on deficiencies of reserves, and through rising discount rates, were nullified. Hence, until the law is amended this phase of the law is held in suspension, and the 40 per cent requirement is rather a danger sign than anything else.

In addition, the federal reserve authorities have taken the view that so long as the reserves of the system as a whole are sufficient, it matters little what the condition of any one of the twelve banks may be, for the Federal Reserve Board has authority to cause any one of the reserve banks to rediscount paper for another, and in this way reserve balances can be shifted at will. The reserve banks may also borrow from one another to "adjust" their reserves. From these operations two technical expressions have arisen: "unadjusted reserves," signifying the reserves which the banks would actually have if they had not borrowed from the other banks, and "adjusted reserves," signifying the reserves after the money borrowed has been added or money loaned has been subtracted. There are arguments both for and against this interpretation of the law. On the one hand, it certainly gives the system more elasticity and unity and possibly makes it more serviceable in emergencies, and there is no doubt that such method of "adjusting" reserves is within the rights of the banks. On the other hand, if the limitations of the law were applied to the banks as individual institutions, more conservative banking would probably be the result.

Another device for obviating deficiencies of reserves has been the substitution of legal tenders for gold. According to the law the legal tenders can be used as reserves only against deposits, and against the notes a gold reserve is required. In recent years legal tenders have constituted a larger proportion of the total reserves of the federal reserve system against its deposits. The substitution of legal tenders for gold in the reserves increases the "free gold" and encourages further expansion. So long as the legal tenders are acceptable freely at par, they will serve as re-

serve quite as well as gold; but a certain risk is thereby incurred, and such use is a pyramiding of credits. Besides it is a fair surmise that the framers of the Federal Reserve Act intended that the reserves against deposits should also be gold, no less than was the case with reserves against notes.

Another factor that affects the reserve ratio is the deposit of gold, legal tenders, and silver by the Treasury. By making such deposits the Treasury might in an emergency relieve the banks from deficiencies of reserves. At any rate it is well, in reading the weekly statements of the federal reserve banks, to observe to what degree the increase of reserves arose from this source and to what degree the banks actually contracted their liabilities.

Movement of Reserve Ratio

The movement of the reserve ratio of a banking system does not necessarily serve in all cases as a true index of strength. The ratio may increase as the result of an increase in cash reserve even though the holdings of paper may be non-liquid, or the ratio may decline as the result of the liquidation of credit at a time when the portfolio is in a satisfactory state and when the reserve is sufficient to meet all probable demands of depositors and noteholders. In other words, in estimating the reserve strength the character of the secondary reserve should be considered.

The history of the required and actual reserves is shown in Figure 7. The process by which the gold of the country was concentrated in the federal reserve banks during 1917, 1918, and 1919 has been described earlier in this chapter. The tide of gold shipments turned against our country during 1919 and 1920, and most of the net exports were taken from the reserve banks. Throughout the period of the war and into 1920 the liabilities of the federal reserve banks for notes and deposits increased quite steadily. Until May, 1919, the accumulation of gold more than supplied the amount of reserve required by law and the volume of excess reserves ("free gold," as it is called) was only slowly

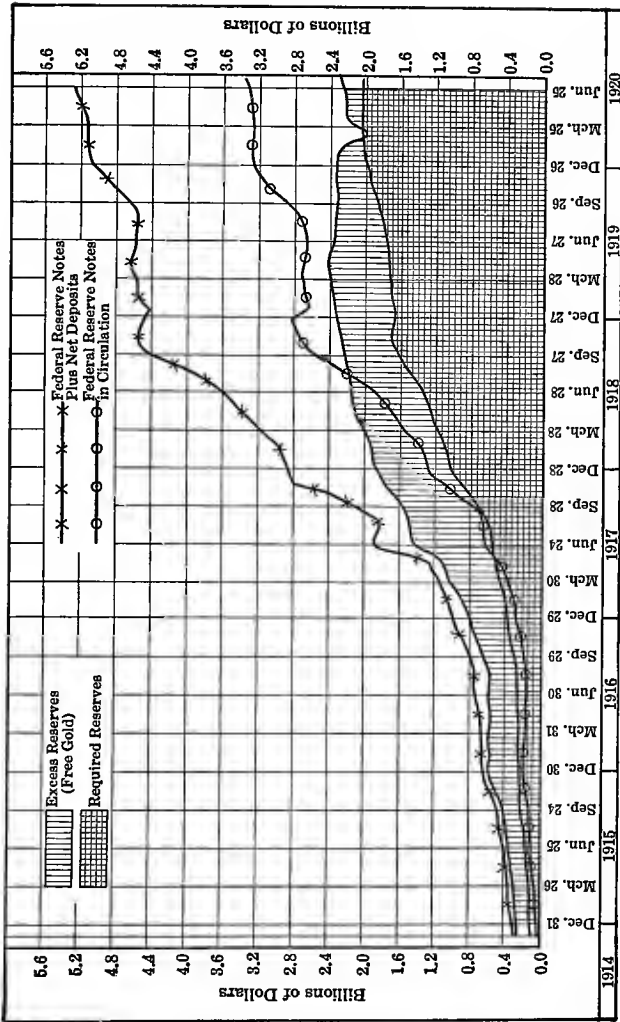

Figure 7. Graphic Chart Showing Reserves of the Twelve Federal Reserve Banks

diminished. The reserve ratio, however, declined meanwhile, but at a moderate rate. But after May, 1919, the conjunction of rising liabilities and declining reserves caused a rapid decline in the reserve ratio, until in February, 1920, the free gold was wiped out and an actual deficit temporarily existed. This served as a danger sign and the federal reserve authorities became more active in stopping expansion.

The expansion from September, 1917, to May, 1919, was almost entirely based upon "war paper." This term signifies notes of the member banks in favor of the federal reserve banks and accompanied with the collateral of Liberty bonds, Victory notes, or certificates of indebtedness, by which the member banks borrowed from the reserve banks. After May, 1919, war paper was contracted, and expansion came through bills discounted for member banks and purchased in the open market. The expansion after the armistice was encouraged by the prevalence of rediscount rates lower than market rates of money, so that it was profitable to use the federal reserve banks as a source of funds. (See "Discount Operations of the Federal Reserve Banks," Chapter XX.)

Characteristics of Federal Reserve Notes

The federal reserve notes are direct obligations of the United States, and are not, therefore, in the strict sense bank notes. They are receivable by all member banks and federal reserve banks, and for all taxes, customs, and other public dues, but they are not a legal tender in settlement of private debts. They are redeemable in gold at the United States Treasury, and in gold or lawful money at any federal reserve bank, and for this purpose each bank is required to carry with the Treasury a redemption fund of 5 per cent or more and to reimburse the Treasury in gold, gold certificates, or lawful money as the fund is depleted by redemptions. The expenses of redemption are charged to the federal reserve bank. The notes of each federal reserve bank bear

a distinctive letter and serial number assigned to it by the board. Whenever federal reserve notes of one federal reserve bank are received by another federal reserve bank they must be promptly returned for credit or redemption to the issuing bank. No federal reserve bank may pay out notes issued through another, under penalty of a tax of 10 per cent per annum on the face of the notes so paid out. The federal reserve notes together with the federal reserve bank notes constitute a first and paramount lien on all the assets of the issuing bank.

The federal reserve notes may not be counted as reserve by either the federal reserve banks or the member banks, although the non-member state institutions may and do so use them, laws to this effect having been passed by certain states. The Federal Reserve Act contemplated the use of the notes for circulation purposes only, the reserves of the members being intended to consist of credit (deposit) balances with the federal reserve banks. It was argued that the elasticity of the federal reserve notes would be very materially impaired by their use as reserves, since once pocketed in bank vaults they would remain outstanding indefinitely; and to the degree that the notes are so held now by state institutions that is the case. It was also argued that to allow member banks to regard federal reserve notes as reserve on which to build a deposits superstructure would result in a plain case of pyramiding credit. In reply it may be argued that, though the federal reserve notes do stay out, nevertheless the volume of the currency may contract, for the recovery of the pledged paper may be made by paying gold or gold certificates. Again, federal reserve notes and deposits with the federal reserve banks are both demand liabilities of those banks and either may be procured by the process of rediscounting, so that it is illogical to allow deposits with the federal reserve banks to count as reserves for a member bank, while inhibiting federal reserve notes in the possession of the member bank from such privilege. Finally, in the case of federal reserve notes used as reserves there

is no less pyramiding of credit than in the case of deposits with the federal reserve bank used as reserves, for they are both demand liabilities of the reserve bank against which it needs to keep but 40 per cent and 35 per cent gold reserve, respectively, and the potential capacity for inflation is as great in the one case as in the other.

Provisions for Controlling Excessive Issues

The original provisions against excessive issues of notes seemed ample to prevent inflation. A 40 per cent gold reserve was required, and this requirement could only be obviated by the payment of a progressive tax, which soon became prohibitive. The discount rate also increased as fast as this tax on the deficiency of the reserve. How these three limitations are being evaded under present practice has been explained above.

When a federal reserve bank applies to its federal reserve agent for a certain amount of notes, the Federal Reserve Board has the right, acting through the federal reserve agent, either to grant the application in whole or in part, or to reject it entirely.

The board may at its discretion fix a rate of interest which shall be charged for the use of the federal reserve notes issued to the reserve bank and in this way force the retirement of the notes when redundant. To date (1921) the board has not deemed it necessary to impose any such interest rate.

In addition the board may impede inflation in any federal reserve district by directly raising the discount rate of the federal reserve bank, either at the instance of the reserve bank or on its own initiative.

As the denominations of the federal reserve notes range from \$5 to \$100 and many are too large, therefore, to stay in general circulation, the notes, particularly of the larger denominations, drift to tills of business concerns and into the vaults of banks, and ultimately to places of redemption.

The board has another means of control in that it may more

strictly define the paper eligible for rediscount if it is found desirable to restrict the pledging of paper for the purpose of securing notes. A stricter definition would reduce the volume of eligible paper and thereby restrict the possibility of note issues except against gold. By requiring that the paper be strictly commercial paper, not only is the volume limited by the amount of business transactions, but the paper, being self-liquidating, provides a means for its payment before maturity. Paper that covers fixed investments and speculations is specifically excluded from rediscounts. Moreover, only short-term paper may be rediscounted, and therefore it is impossible to rediscount to an unlimited amount since some paper is coming due every day and must be paid through the member bank that discounted it. But this limitation on inflation is defeated by the permission granted to member banks to procure advances from the federal reserve banks on their promissory notes secured by the deposit or pledge of United States securities. Under this permission the federal reserve banks have been surfeited with "war paper" and their liabilities for notes and deposits have expanded altogether too easily. To the degree that the assets of the reserve banks consist of such promissory notes secured by pledge of government securities, to that degree does the character of the federal reserve notes approach that of the national bank notes so far as the non-commercial quality of their security is concerned.

Responsibility for Stemming Inflation

It is obvious that the ultimate control of note issue rests with the Federal Reserve Board, and, therefore, upon the personnel and policies of the board the possibility of inflation depends. If its members are conservative and conscious of their high public responsibility, the board will try to stifle anything in the nature of inflation. But for this it is necessary that the board have the support of the federal reserve banks and the member banks. Each of three parties concerned has a duty to perform in con-

trolling expansion, and though the problems of the three are inter-related, they are nevertheless distinct.

The board has little direct contact with the member banks; it deals with general conditions and principles rather than with individual cases and details, whereas the reserve banks are in daily contact with the member banks and also with the board. The primary duty of the board is to see that the reserve banks function according to law, and its own regulations must, of course, also conform to the law.

The regulations laid down by the board and the definitions made for eligibility of paper for rediscount have to conform with Section 13 of the Federal Reserve Act. In that act no express condition is made regarding the essential or non-essential character of the transaction giving rise to a commercial paper which may be offered for discount, and the board is not required, and properly could not be expected, to adopt such a criterion of eligibility. That is a matter that should be determined locally by the member bank, which knows the conditions and purpose of the loan. No part of the Federal Reserve Act requires the reserve banks to discount any particular paper or class of paper; the law is simply and entirely permissive. Section 4 of the act requires the directors of the reserve bank to administer its affairs "fairly and impartially and without discrimination in favor of or against any member bank," and, subject to the provisions of the law and the orders of the Federal Reserve Board, to extend "to each member bank such discounts, advancements and accommodations as may be safely and reasonably made with due regard for the claims and demands of other member banks."

Thus, according to Section 4, the directors of the reserve banks have the power to limit the volume and character of loans which in their judgment may be safely and reasonably made to any member bank. Nevertheless the Federal Reserve Board has taken the position that, while the reserve banks may properly undertake in their transactions with the member banks to dis-

criminate between essential and non-essential loans, such discrimination might much better be made at the source by the members themselves. In other words, the board does not assume the whole responsibility of stemming inflation, but relies upon the co-operation of the reserve and member banks.

Safety of Federal Reserve Notes

The federal reserve notes also seem as safe as they can be made. They are direct obligations of the United States government, which retains a first lien on all the assets of the federal reserve bank, to protect the federal reserve notes and federal reserve bank notes. The bank is required to maintain a reserve of 40 per cent in gold, and to pledge commercial paper for the remaining 60 per cent, or so much of it as is not covered by gold. This paper, by definition of the board, is restricted to the very best forms of commercial paper, resting upon actual commercial transactions, running for short terms, and bearing two names. These facts, in conjunction with the limitations on inflation, seem to make the federal reserve notes as safe as the credit of the government plus the credit of the business world. The advances based on United States securities, it may be remarked, make the element of government credit still more important in the safety of the notes.

Elasticity of Federal Reserve Notes

The intention of the system was to provide an elastic currency, which would provide not only for emergencies but also for the seasonal variations in the demand for money. The system seems altogether capable of doing both. It was not inaugurated in time to meet the emergency in 1914, and since that date no emergencies have occurred to really test it, although the giant operations in financing the war would have proved real emergencies under the old national bank system. The unused potential loaning power of the federal reserve banks is 2.5 times their surplus gold reserves;

but even this does not represent their full potentiality, for the federal reserve banks may loan more than 2.5 times their gold reserves, provided they pay taxes on the deficiency of reserves, and in great emergencies the Federal Reserve Board may suspend all reserve requirements. The real limitation consists, therefore, not in the scarcity of gold reserves, but in the scarcity of paper eligible for rediscount and for hypothecation for notes. The dearth of double-name paper is due to the American system of business with its single-name paper, open book accounts and cash discounts and to the want of a system of bankers' acceptances. Spirited efforts are being made to develop a trade acceptance system, a bankers' acceptance system, and a discount market. In order to facilitate war finance there was developed the plan of member banks selling securities to the federal reserve banks with agreements to repurchase, and the plan of member banks borrowing from the federal reserve banks on the basis of their notes accompanied by government securities as collateral. By these devices the federal reserve system has attained great capacity to meet emergencies. In practice the member bank in any payments of rediscounts, loans, or collections made to it, largely takes deposit credit at the federal reserve banks, rather than reserve notes, but this is a matter of arrangement between the two banks and is based on convenience.

The Federal Reserve Act planned to effect elasticity of note issue by ready issue of federal reserve notes in payment of rediscounted commercial paper, and by the contraction of the issue as this paper matured. If business should increase in a community, the loans and discounts of the member bank would increase until its reserve fell to the required minimum; to enlarge its credit reserve with the federal reserve bank and to get quantities of federal reserve notes to pay out over its counter, the member bank would rediscount some of its discounted commercial paper to the federal reserve bank. To procure these notes, the federal reserve bank would pledge rediscounted paper with the

federal reserve agent. The volume of federal reserve notes issued would, therefore, be determined by the business needs of the federal reserve district. Member banks could not use these notes as reserve, but they could pay them out over their counters, or send them to the federal reserve banks or to the United States Treasury for redemption. The federal reserve bank receiving the note of another reserve bank would be required to send on the note for redemption or credit, and would not be permitted to pay it out over the counter under penalty of a 10 per cent per annum tax. When the pledged paper became due it presumably would be covered with federal reserve notes or gold. Federal reserve notes worn out or mutilated would also be sent to the Treasury for redemption. By these devices it was thought that the reserve notes would fluctuate in volume with the business needs of the country.

It has been shown above, however, that the policy of the federal reserve banks, while they were concentrating the gold supply, was to cover the pledged paper with gold, leaving the federal reserve notes in circulation and not reduced in volume. By this covering process the total volume of circulating media was reduced, and although the federal reserve notes did not tend to fluctuate greatly in volume to meet the seasonal demands, the total currency did so fluctuate. Federal reserve notes are readily issued to meet the demands of business, and, when the strain has passed a certain amount of gold, federal reserve notes, or some other kind of currency is subtracted from the total currency. The total volume of currency, therefore, rather than the volume of federal reserve notes alone, is elastic, varying with the needs of business and the international adjustment of the gold supply. The greenbacks, silver dollars and certificates, national bank notes, and federal reserve bank notes, are inelastic credit instruments in our circulating media; but over and above these are the federal reserve notes, which, as shown, provide an elastic superstructure.

Statistical verification of this seasonal elasticity has been made quite impossible during the last few years on account of the dominating influence of the Treasury financing. Figure 8 is arranged for seasonal comparisons.

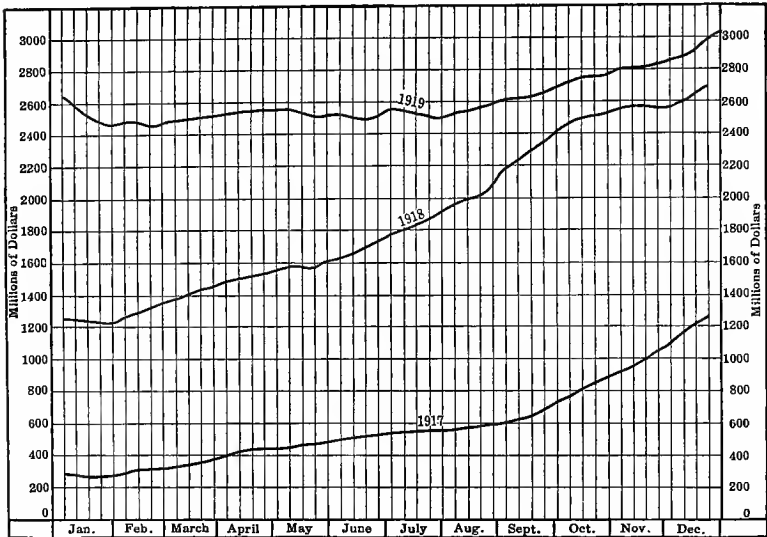

Figure 8. Graphic Chart Showing Seasonal Variations in Federal Reserve Note Circulation

The system of issue and redemption of federal reserve notes which has been adopted has had a marked and beneficent effect on our monetary media. The Treasury, federal reserve banks, and the member banks co-operated to substitute federal reserve notes for gold certificates. The reserve notes have increased rapidly in circulation, whereas the gold certificates are pocketed in the federal reserve banks and with the federal reserve agents. The large greenbacks are also being concentrated in these hands or are being converted into small denominations which are finding a permanent field of circulation. The void left by these with-

drawals is filled with federal reserve notes. The national bank notes will be gradually retired. Thus the currency of the United States is being simplified and federal reserve notes are fast becoming the only currency of \$5 denomination or higher. The process of reducing the denominations of the greenbacks and national bank notes, and the process of saturation of the currency with federal reserve notes, render the objectionable greenbacks, silver certificates, and national bank notes less annoying and threatening.

CHAPTER XX

DISCOUNT OPERATIONS OF THE FEDERAL RESERVE BANKS

Paper Eligible for Rediscount

The discount operations of the federal reserve banks are of three classes:

1. For member banks.
2. Open-market purchases and sales.
3. For other federal reserve banks.

Paper that is eligible for rediscount is defined by Section 13 of the Federal Reserve Act and by Regulation A of 1917 of the Federal Reserve Board. Paper eligible for purchase in the open market is defined in Section 14 of the act and in Regulation B of 1917. In general terms the definitions limit these operations to paper based on commercial origin having short maturity, and bearing the indorsement of a member bank (if it is for rediscount). During the war it was found advisable to admit to discount "war paper" (i.e., notes of a member bank in favor of the federal reserve bank and accompanied by United States securities as collateral). War paper is not commercial, and the proceeds may or may not be used to extend loans for commercial purposes.

1. Rediscounting for Member Banks

Before 1914 one of the serious defects in the American banking system was the want of a discount market—a dependable source of funds for the banks at all times, on the basis of commercial paper. The federal reserve banks provide by the rediscount process such a source for the member banks, who are thus no longer dependent upon their correspondents for accommodation.

Until June, 1917, however, the member banks had made relatively little use of the rediscount privilege. The operation was novel to most members and the inertia of custom was enough to keep them from using the federal reserve banks as a source of funds. There was also a sentiment adverse to rediscounting, for to rediscount the paper of customers was thought to reflect discredit upon a bank's management and this unwarrantable sentimental objection had to be smoothed away. The wide-spread skepticism of country banks about the federal reserve system, the general attitude of waiting to see what it would do, and the ignorance of the banking fraternity concerning the new system, were also contributory factors toward delaying rediscounts. Finally, there was a dearth of eligible paper in the portfolios of the members.

These various obstacles in the way of rediscounting were lessened by a campaign of education about the new system, by the development of acceptances as a commercial instrument, by the cumulative experience of members with the reserve banks, and by the admission of many state banks to the reserve system.

Effect of War on Discount of Commercial Paper

The most important cause of change in attitude towards rediscounting was the necessities of war finance, with its huge spasmodic receipts and payments handled through the banks. The war made it necessary to have an ever ready source of funds in large abundance, and this was afforded by the reserve banks. As the discount rate at the reserve bank was prevailingly below the market rate for funds, the motive of profit also inclined the member to use the reserve bank rather than the correspondent with which it had previously dealt.

On the other hand, the use of war paper lessened the necessity for the use of commercial paper, and the great preponderance of borrowings by members from the reserve banks has been on war paper. War paper as an element in the earning assets of the

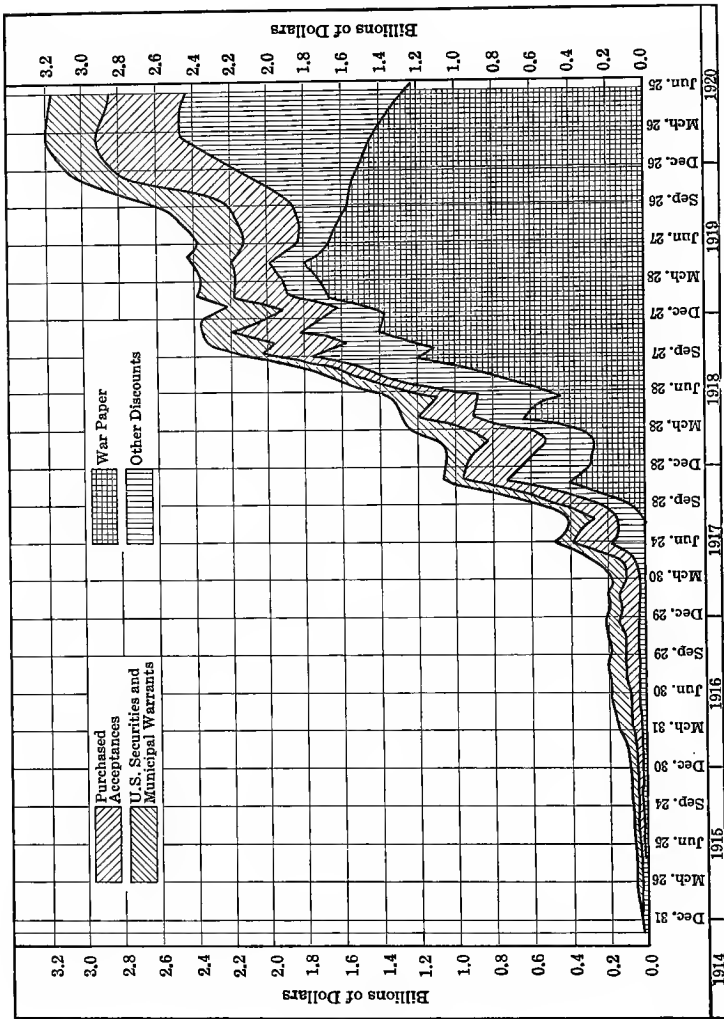

Figure 9. Graphic Chart Showing Earning Assets of the Federal Reserve Banks, 1914-1920

reserve banks reached its height in May, 1919. Since that date, not only has the volume of war paper declined but the volume of commercial bills has increased faster than the volume of war paper has declined, with the result that the commercial paper now (1921) constitutes about half of the earning assets, and the fraction will continue to grow larger. Many of these facts are shown by Figure 9.

Statistical Statement of Rediscounts

War finance operations have so disturbed discount operations that it is impossible to show the normal seasonal variations in the discount holdings of the reserve banks. Undoubtedly as soon as the Treasury operations become stable and normal, the graph of average monthly holdings of the system as a whole and of each reserve bank will show a certain symmetry for the various seasons.

The relative activity of the twelve reserve banks in discounting is indicated by the average daily holdings of discounted bills for the years 1919 and 1920:

Bank	1919	1920
Boston.....	\$ 142 million	\$ 169 million
New York.....	726	847
Philadelphia.....	193	190
Cleveland.....	126	179
Richmond.....	94	104
Atlanta.....	87	115
Chicago.....	209	417
St. Louis.....	68	109
Minneapolis.....	41	76
Kansas City.....	83	106
Dallas.....	52	71
San Francisco.....	81	142
	\$1,908	\$2,530

The number of banks accommodated through discounting grew as follows:

Year	Number of Banks
1917	3,127
1918	5,493
1919	5,993
1920	6,941

The short maturity of discounted bills is highly important in maintaining the liquidity of the system. On this basis the discounted paper holdings of the reserve banks on December 26, 1919, were distributed as follows:

Maturity	Amount
Within 15 days.....	\$1,484 million
From 16 to 30 days.....	245
From 31 to 60 days.....	293
From 61 to 90 days.....	152
Over 90 days.....	20
	<hr/>
	\$2,194

The calculated average of all such discounts for 1919 was 10.13 days.

2. Open-Market Operations

The discount market is enlarged also by the open-market operations of both the member banks and the federal reserve banks. Member banks buy, as do the federal reserve banks, from discount companies, note-brokers, and other holders of bills. The Federal Reserve Act permits the federal reserve banks, under rules and regulations prescribed by the Federal Reserve Board, to purchase and sell in the open market bankers' acceptances and bills of exchange of the kinds and maturities made eligible by the act for rediscount, with or without the indorsement of a member bank, such purchasing and selling being permitted with banks, firms, corporations, or individuals. The open-market purchases have been made chiefly by the reserve banks in New York and

Boston, which are the principal acceptance markets. Some of the interior reserve banks, however, participate in the open-market purchases of the Federal Reserve Bank of New York under an agreement approved by the Federal Reserve Board, the New York bank allotting to the interior banks certain amounts of its purchases. In order to maintain an open market for bankers' acceptances, the reserve banks of Boston and New York have been called upon to make heavy purchases, and then it has been necessary for these banks, in order to maintain their reserves, to make large sales of acceptances. The total amount of acceptances bought in the open market by the twelve banks has grown as follows:

Year	Amount
1915	\$ 65 million
1916	368
1917	909
1918	1,809
1919	2,825
1920	3,218

The open-market operations throw the reserve banks into competition with the member banks for investments. Besides giving the reserve banks a source of earnings and enlarging the discount market, they give the reserve banks a control over the money market and over the member banks. It is expected that, when the foreign exchanges are again on a gold basis and are more normal and stable, the reserve banks will be able to influence the importation and exportation of gold by entering the open market.

3. Rediscount Operations Between Federal Reserve Banks

All rediscount operations between the federal reserve banks are arranged by the Federal Reserve Board, under authority of Section 11 of the Federal Reserve Act, which provides that a federal reserve bank may be permitted or, upon the affirmative

vote of at least five members of the Federal Reserve Board, required to rediscount the discounted paper of another federal reserve bank at rates of interest fixed by the board. There has been such a spontaneous spirit of co-operation between the federal reserve banks that all transactions suggested by the board have been voluntarily made, and in no case has the board found it necessary to exercise its statutory authority to require such operations. By means of the federal reserve leased-wire system, rediscount operations are consummated almost instantaneously, payments being made by transfers through the gold settlement fund. Practically every day of the year such transactions take place between some of the reserve banks. The transfer of funds in connection with the fiscal operations of the Treasury, and that occasioned by the seasonal requirements for handling the crops and for purchasing raw materials by industries, as well as the necessary transfer of funds for the adjustment of reserves, cause a considerable movement of bills between the various districts. The rediscount operations between the federal reserve banks for the calendar year 1920 amounted to \$3,672,000,000, including \$212,000,000 of purchased bills.

Discount Rates of Federal Reserve Banks

Section 14 of the Federal Reserve Act clothes any federal reserve bank with the power to establish from time to time, subject to review and determination by the Federal Reserve Board, rates of discount to be charged by the federal reserve bank for each class of paper, the only requirement of the law being that the rates shall be fixed with a view to accommodating commerce and business. The board has also the power to define the classes of paper.

The following table gives the classification of paper and the respective rates as approved by the board at a recent date. Changes are made from time to time, as expediency dictates, in each respective district. Although the rates in the twelve dis-

RATES ON PAPER DISCOUNTED FOR MEMBER BANKS APPROVED BY
THE FEDERAL RESERVE BOARD, IN EFFECT JUNE 26, 1920

Federal Reserve Banks	Discounted Bills Maturing Within 90 Days (In- cluding Member Banks' 15-Day Collateral Notes) Secured by		Bankers' Acceptances Maturing Within 3 Months	Trade Acceptances Maturing Within 90 Days	Discounted Bills Secured Otherwise Than by Govern- ment War Obligations Also Unsecured, Maturing Within	
	Treasury Certificates of Indebtedness	Liberty Bonds and Victory Notes			90 Days (In- cluding Mem- ber Banks' 15- Day Collateral Notes)	91 to 180 Days (Agricultural and Livestock Paper)
Boston.....	5½	6	...	7	7	7
New York....	5½	6	6	7	7	7
Philadelphia..	5½*	5½	5½	6	6	6
Cleveland....	5½	5¾	5½	5¾	6	6
Richmond....	5½	6	6	6	6	6
Atlanta.....	5½*	5½	5½	6	6	6
Chicago.....	5½	6	6	7	7	7
St. Louis.....	5½*	5½	5½	6	6	6
Minneapolis..	5½	6	6	6½	7	7
Kansas City..	5	5½	5½	6	6	6
Dallas.....	5½*	5½	5½	6	6	6
San Francisco.	5½	6	5½	6	6	6

*5½ per cent on paper secured by 5¼ per cent certificates, and 5 per cent on paper secured by 4¾ and 5 per cent certificates.

NOTE. Rates shown for Atlanta, St. Louis, Kansas City, and Dallas are normal rates, applying to discounts not in excess of basic lines fixed for each member bank by the federal reserve bank. Rates on discounts in excess of the basic line are subject to a ½ per cent progressive increase for each 25 per cent by which the amount of accommodation extended exceeds the basic line.

districts are approximately equal, no effort is made to keep them exactly equal, nor are the same changes made from time to time simultaneously in all districts, nor for all classes of paper. By the system of interdistrict rediscounts the Federal Reserve Board can render the strain on the money market fairly equal. The board has taken the position that changes in discount rates cannot become effective without its previous approval. On the other hand, the reserve banks, through the reserve agents, may apply

to the board for changes in rates. The initiative, in other words, may be either with the board or with the reserve bank.

The determination of its discount policy is one of the most important of the administrative functions of the Federal Reserve Board. Not only does the board exercise a direct control over discount rates but it can also through official publication bring a tremendous pressure to bear upon the banks to conserve credits for essential uses. A raise of the discount rates by $\frac{1}{4}$ per cent at a critical time precipitates a fall of 10 or 15 points on the stock market, not because of this very small increase in the cost of borrowed funds but because it indicates that this body of unbiased experts deems the banking situation critical and the borrowers realize the potential power of the board to establish prohibitive rates and force contraction. The board talks the language of public interest and far-sightedness and acts as moderator. It also acts for the system as a whole, as against the interest of a particular district. The rates of discount established are the same to all member banks and are made public. Hence a customer of a member bank knows at what rate his bank is procuring funds; if there is too wide a difference between this rate and the rate charged him, he has a proper cause for complaint. The equalization of discount rates at the reserve banks tends, therefore, to an equalization of discount rates at the local banks, for loans of the same quality. Rates that favor a certain class of paper tend to change the mercantile credit system.

Factors Influencing Discount Policy of Federal Reserve Board

In the determination of its discount policy the Federal Reserve Board has been influenced by a number of factors.

In the first place, throughout the period of our participation in the war it was the desire of the Treasury that the loans of the United States be placed at low interest rates, and to this end the banking system was constrained to facilitate subscriptions to the loans at rates approximately equal to the rates borne by the

bonds. A subscriber, for instance, was provided with a loan at, say, $4\frac{1}{2}$ per cent by his local bank, on his note for \$900 with the purchased 4 per cent security as collateral, on condition that the subscriber would pay \$100 down. The local bank was able to borrow at, say, $3\frac{3}{4}$ per cent from the federal reserve bank on its note with United States securities for collateral, and the margins between these rates were scarcely enough to cover the expense to the banks. As the subscriber through his savings liquidated his loan, the member bank was able to pay its debt to the reserve bank. This loan policy prevented the board from adopting a strictly economic policy so long as its pledge to subscribers was in effect; and thereafter shifts to a higher discount rate basis had to be by small gradations and to a moderate height, lest the money market be seriously disturbed and the war securities, along with all others, be depressed. Not until 1920 did the board advance rates to any large extent.

Again, the United States after the war stood almost alone as an important free gold market. Raising the rates of discount has not been an effective method of attracting gold to this country and easing the money market, as would have been the case in normal times. The consumptive and speculative demand, both foreign and domestic, for goods in the United States has been so intense that buyers have been little restrained by high interest rates. These conditions have been adverse to an easy and effective control of credit by means of discount rates, and the board has tried to deter credit expansion by other means than raising these rates.

Then, too, the board has been urged by Senator Owen and others to fix discriminating rates against stock exchange and other speculative loans, and leave the rates to commercial and industrial enterprises at a low figure. In so proposing, Senator Owen argued that the prevailing high call loan rates were diverting money from desirable lines to the speculative market, that such speculation was undesirable and dangerous, but that the

raising of all discount rates, far from remedying the situation, would simply penalize commerce and industry. He was anxious that the board should so regulate the discount rates as to sustain the market value of United States securities. The board answered that it was not the proper province of the board to determine whether a loan was essential or not, that that matter should be decided by the reserve and local banks, and that the law did not authorize the board to fix rates that would sustain the value of the government securities.

The board has adopted the policy of "preferential rates" on certain forms of paper. The lower rate on acceptances was adopted with the idea of changing our mercantile credit system from the open book account to the trade and bank acceptance system. During the war lower rates were given to war paper. Under this policy agricultural paper is also favored.

Moreover, lower discount rates are given for short-term paper, upon the principle that the security on long-term paper is not as good as on short-term, since the shorter the maturity the less the probability that the funds obtained will be used for non-commercial and long-term financing.

The board has opposed the practice of certain clearing houses in fixing a sliding scale of rates of interest paid on deposits and using the rediscount rate as the base, inasmuch as it wishes to be free to fix its rates of discount without reference to any clearing house regulations.

The board has maintained discount rates lower than the prevailing market rates. In this respect it has differed from the practice of all European central banks. One defendant of the system has argued that the reduction of the element of risk in its loans was sufficient warrant for the difference in rates. It is probable that a fundamental original reason was a desire to popularize the federal reserve system, and to induce the state institutions to join. The wide disparity between the two rates during recent years has made the facilities of the federal reserve extraor-

dinarily profitable for the members. Now that the system is well established and expansion has reached a dangerous degree, it seems desirable to adopt the European system, having the rediscount rate higher than the market rate and making it a source of loss rather than of profit for a member bank to rediscount, and thus rendering rediscount operations rather emergency than every-day activities.

Control by Lines of Credit

The urgent need of restraining bank expansion in 1920 led to an amendment of the Federal Reserve Act to the effect that the discount rates of the federal reserve banks, fixed "subject to the approval, review and determination of the Federal Reserve Board may be graduated or progressed on the basis of the amount of the advances and discount accommodations extended by the federal reserve bank to the borrowing bank." The board and reserve banks can put this amendment into effect only through uniform rules applying to all member banks alike without discrimination. Under this device the reserve bank will establish "lines of credit" for its members, and the member banks will know in advance that funds borrowed beyond a specified figure will involve a specified penalty above the published discount rate, graded upward as its borrowings exceed its normal line. This will stabilize the published rate and confine the fluctuations chiefly to the surcharges. This elastic limit is better than the actual refusal of the reserve bank to extend further accommodation. Certain of the reserve banks have adopted this new system; others rely upon raising the general rate level.

A reserve bank which adopts the plan of extending lines of credit sets a basic line to which the normal or basic discount rate applies. The basic line adopted (1920) by the Atlanta, St. Louis, and Kansas City banks is two and one-half times a sum equal to 65 per cent of the member bank's average reserve balance plus its paid-in subscription to the capital stock of the federal reserve

bank, both calculated over a fixed period either preceding or identical with the period to which the basic line applies. For the Dallas district, however, a basic discount line is used equal to the paid-in capital and surplus of the member bank. The Atlanta and St. Louis banks apply the normal rate to all offerings for re-discount, and apply a progressive "super-rate" at the end of the reserve computation period to the average borrowings in excess of the basic line. The Kansas City and Dallas banks impose the super-rate upon such part of the current offering as may, together with the outstanding borrowings, be in excess of the basic line. As a scale of rates, all four banks increase the rate by $\frac{1}{2}$ per cent for anything up to 25 per cent in excess of the basic line, 1 per cent for the second 25 per cent excess, $1\frac{1}{2}$ per cent for the third, and 2 per cent for the final quarter. Exceptions are made for certain member bank collateral notes secured by government obligations.

CHAPTER XXI

RESERVES AGAINST DEPOSITS UNDER NATIONAL BANKING ACT

Legal Requirements

The Act of 1864 required that national banks located in the seventeen principal cities named carry reserves consisting of lawful money, equal to 25 per cent of the aggregate amount of their circulation and deposits, and that all other national banks keep similar reserves, which, however, needed to equal only 15 per cent.

Whenever the reserves on hand fell below these minimum amounts for any bank, the bank was forbidden to make time loans, to discount time paper, or to pay dividends. Three-fifths of the 15 per cent required reserves might be carried as balances with approved banks of the seventeen cities named and thus be available to redeem the circulation of the bank.

The Act of 1874 abolished the reserve requirements against national bank notes, and provided that the 5 per cent redemption fund against national bank notes might be counted as part of the required reserve against deposits.

The Act of 1887 provided for additional reserve cities. Whenever three-fourths of the national banks located in any city having a population of 50,000 or over applied to the Comptroller of the Currency to have their city added to the list of cities above mentioned, the Comptroller was empowered to grant the request, and the city was thereafter known as a "reserve city." Though all the banks in such city were thereafter required to have reserves equal to 25 per cent of their deposits, they had the profits and advantages arising from the bank balances carried with them. The classification of the banks, therefore, turned on the

net balance of these advantages and disadvantages and proved to be somewhat artificial, for in many cities the banks were technically country banks, while in many smaller places they were reserve city banks.

Also, whenever three-fourths of the national banks in any city having 200,000 population or over requested it, the Comptroller might designate it a "central reserve city," in which one-half of the lawful money reserve of the reserve city banks might be deposited, and such city was required thereafter to carry reserves equal to 25 per cent of its deposits.

The Act of 1903 reduced the minimum population of a reserve city from 50,000 to 25,000.

System of Redeposited Reserves

Under the laws of 1864, 1887, and 1903, a complicated system of redeposited reserves against deposits developed which may be presented by the chart on page 389.

Bank Correspondents

Under the National Bank Act no bank was required by law to carry any reserve with banks in reserve or central reserve cities, but it was permitted to do so if it found it advantageous. No bank, however, kept its entire reserve in its own vaults. Every bank found it necessary to carry balances with other banks in the larger centers of trade to facilitate the domestic exchanges and to accommodate their customers in making settlements at a distance. These balances were essentially checking accounts against which the local banker sold domestic exchange and which he would have had to carry irrespective of whether they counted as reserves; it was a particular favor to the banks to permit such balances to be regarded as part of their required reserves. To count them as reserves rested upon the assumption that they were available upon demand and, in turn, that the reserve bank kept them in liquid form.

CHART SHOWING SYSTEM OF REDEPOSITED RESERVES

Country banks:

Received deposits from:

Individuals, etc.

State banks and trust companies

The government

The reserve required was 15 per cent

The reserve was to be carried:

 $\frac{2}{5}$, or more, in its own vaults $\frac{3}{5}$, or less, in { central reserve city banks.....>.....>
reserve city banks.....>.....>

Reserve city banks:

Received deposits from:

Individuals, etc. ✓

State banks and trust companies

The government

Country banks.....<.....<

The reserve required was 25 per cent.

The reserve was to be carried:

 $\frac{1}{2}$, or more, in its own vaults ✓ $\frac{1}{2}$, or less, in central reserve city banks.....>.....>

Central reserve city banks:

Received deposits from:

Individuals, etc. ✓

State banks and trust companies

The government

Reserve city banks.....<.....<

Country banks.....<.....<

The reserve required was 25 per cent.

The reserve was to be carried in its own vaults.

Each country bank chose one or more reserve agents in one or more reserve and central reserve cities, and each reserve city bank chose one or more reserve agents in one or more central reserve cities. These agents were commonly spoken of as "correspondents"—New York correspondent, Pittsburgh correspondent, etc. Very intimate co-operative relations were developed

between the correspondent and customer banks. Out of consideration for the balance carried the reserve correspondent undertook various lines of service for its customer bank, and competition among reserve agents for these accounts amounted to a contest in the kind, amount, and quality of the services offered.

Banks carrying good balances could reasonably expect ready and ample accommodation by way of loans if they faced sudden and unexpected demands for cash, knowing that the reserve agent when called upon by wire would remit in as liberal and expeditious a manner as possible. The reserve agent, among other services, acted as financial adviser to its bank customers—answered their credit inquiries about names found in its credit files, bought and sold securities and commercial paper for them, acted as agent in loaning their money in the reserve city, made payments to and received payments from the United States Treasury and sub-treasury, handled their foreign exchange connections, and provided an agent at Washington, D. C., to care for inspection of securities, notes, plates, etc.

Probably the two most important services rendered by the reserve correspondent were the handling of collections, on which it sometimes absorbed the exchange charges, and the payment of interest on the net average balance. The local bank arranged to send to the reserve agent as many of its collection items on out-of-town parties as it found expedient, and the exchange charges on these items were a source of profit to the reserve agent. The reserve agent reciprocated by sending to the local bank customer all its collections on parties in that district, out of the proceeds of which the customer deducted exchange charges high enough to constitute a fair profit. Through its customer banks, the reserve banks established national connections and got into contact with innumerable areas, customers, and lines of business. The competition for customer bank balances led to paying interest of 2 per cent or more on the balances and to various agreements as to when transit and collection items should be credited and

remittances debited and when interest should start. The payment of interest was the most powerful force in shifting the spare funds and the reserves of national and other banks to the banks of reserve and central reserve cities.

Effect of System on Concentration of Money

The result of the system was a high degree of concentration of money in the three central reserve cities and in relatively few banks even there. According to the returns of the last Comptroller's call before the enactment of the Federal Reserve Act, October 21, 1913, the concentration in the central reserve cities was as follows:

TABLE SHOWING CONCENTRATION OF MONEY IN CENTRAL RESERVE CITIES, OCTOBER 21, 1913

(Amounts in millions)

	NEW YORK	CHICAGO	ST. LOUIS	TOTAL
Number of national banks.	36	9	7	
Total deposits.	\$1,356	\$456	\$144	
Individual deposits.	715	215	62	\$993
Bankers' deposits:	641	241	82	965
Due to other national banks	337	149	53	
Due to state and private banks.	122	76	26	
Due to trust companies and savings banks.	181	14	3	

In other words, about half of the total deposits of these central reserve cities were bank balances, and over half of the bank deposits were from national banks. The Pujo Money Trust Investigating Committee in 1912 found that ten of the leading banks and trust companies of New York had 15,483 bank depositors distributed as follows:

1. Hanover National Bank.....	4,974
2. Chase National Bank.....	3,103
3. National Park Bank.....	2,426
4. National City Bank.....	1,889
5. National Bank of Commerce.....	1,671
6. Mechanics and Metals National Bank.....	1,010
7. First National Bank.....	579
8. Liberty National Bank.....	312
9. Bankers Trust Company.....	237
10. Guaranty Trust Company.....	182
Total number of bank depositors.....	15,483

Competition for Deposit Balances

Although these bank balances were not very profitable to the reserve banks, the correspondents were useful in giving access to business lines and houses in every part of the United States. Accordingly the central banks waged a serious campaign to attract them, particularly after the 1900 amendment to the National Banking Act and the rapid expansion of national banks that resulted therefrom. The chief inducement offered to the banks to make such deposits was the interest allowed. The bidding was at first competitive, and varying rates were paid. By a process not quite understood the rate most commonly adopted came to be 2 per cent, which rate was not determined by careful cost and profit analysis but rather by guesswork. At first interest was allowed only on balances of banks, but later on, owing to competition, interest was paid on balances of insurance companies, railroads, big capitalists, and on all accounts of unusual size. Some banks came to make general rules to pay interest on all balances above certain minimum amounts, others kept to the practice of private arrangements with each depositor.

Effect of Redeposited Reserves on Securities and Money Markets

The payment of interest on deposits, undertaken in addition to the other multiplex services of the reserve city banks and

brought about by the force of competition among the reserve city banks for these accounts, resulted in making them unprofitable unless the funds were, as nearly as possible, employed constantly and at good rates and at call. Therefore the reserve banks were inclined to seek profitable investments based upon these balances, and because of the want of a discount market the banks built "lines" of demand loans to stock exchange speculators for trading purposes; if such loans were called, the speculators would liquidate the securities and pay their loans, and thus replenish the bank with funds to meet the demands of their correspondents—an operation which was perfectly safe when the market was buoyant but dangerous in times of panic.

The system tended to cause temporary superabundances and temporary shortages of loanable funds in the central reserve cities. During the dull seasons in the agricultural regions, for example, the banks would have excess funds and would remit these to their reserve agents, either to add to their balances on which they received the customary 2 per cent interest, or to have the agents invest for them in brokers' loans, securities, etc., so as to take advantage of the higher money rates on the market. The plenitude of funds in the reserve cities lowered money rates and eased the way for the speculators, and at the same time inflated the prices of securities. An inflation of stock exchange operations followed. With a revival of activity in the agricultural regions the local bank would recall part or all of its balances from the reserve cities and possibly become a borrower. The result was that it became impossible to maintain the stock market, money became tight, loans were contracted, investments were liquidated, and values fell.

In case of panic these conditions were accentuated and it became impossible to recover the "reserve" funds by liquidating the securities in which they were actually invested, or practically invested through call loans, without producing so severe a shrinkage of values as to cause wide-spread bankruptcy. The banks were

therefore often obliged to suspend specie payments. For want of a broad discount market where such seasonally spare funds might have found investment in commercial paper, the re-deposited reserve plan forced the collateral call loan system, fostered an unsteady securities' market and money market, and confused commercial banking with financial banking. In the panic of 1907 this dependence upon the stock market was so convincingly proved to be dangerous and vicious that banks ceased to a large degree to make seasonal deposits and withdrawals from New York.

Effect on Cash Carried, Exchange, and Accommodation

The interest on the balances drew the funds to the reserve cities and then forced the reserve city banks to loan and invest them. The result was that the national banks as a whole kept on hand very small amounts of actual cash in excess of the minimum reserve requirements; or, stated more accurately, loans were extended as far as possible under the law. It was a case where the excess reserves were carried with reserve agents who were in competition and who were motivated primarily by the desire for profits, and who, therefore, from the pressure of competition had to make dangerous extensions of credit on the basis of such reserve balances. Instead of the balances being, as in theory they were and ought to be, carried for exchange purposes, and carried, too, in liquid shape and payable on demand, they were made the basis of a credit structure which toppled when the balances were recalled.

One of the considerations which the depositing bank had in view in maintaining such balances was to have a dependable source of accommodation in case it needed loans; but if the reserve bank had already loaned to the limit, its ability to support its clients was nullified. In the fall months from 1902 to 1912 inclusive, the reserves of the New York banks averaged 1.4 per cent above the minimum required, which stands in wide contrast

to the reserves voluntarily kept by the central banks of Europe which assume the rôle of reserve agent. The banks in the reserve cities depended upon their secondary reserves and these proved very treacherous in falling security markets, when the call loan is inconvertible except at a sacrifice.

Reserves and Stock Exchange Loans

The fault here was in the system, not in any particular banks, nor in a special desire of the banks to facilitate stock exchange speculations. The banks were institutions for profit; they were competing; funds if idle were a source of loss; interest had to be paid to hold the account; investment of the funds was forced; the reserve banks had to depend upon secondary reserves which would be earning assets; since there were no facilities for rediscounting commercial paper, the best secondary reserve open was the collateral stock exchange call loan. The system hurt the banks as well as the country at large. The banks would have avoided the dangers if it had been possible, but they were in the grip of a faulty system from which they could not escape.

If the balances were used as the basis of *time* loans the hazard to the bank was increased, for its *demand* liabilities were offset by *time* assets. The banks' relative readiness to loan on time or call varied with the ease or tightness of the money market.

In his report in 1912 the Comptroller classified the loans of the New York national banks on June 14, 1912, as follows:

	Demand	Time
Unsecured paper with one or more individual or firm names	\$ 17,796,000	
Secured by stock, bonds, or other personal security	326,897,000	
Total	<u>\$344,693,000</u>	
Unsecured single-name paper (one person or firm)		\$219,172,000
Paper with two or more individual or firm names		<u>171,791,000</u>
Total		<u>\$390,963,000</u>

Secured by stocks, bonds, or other personal security, or on mortgages or other real estate security.....	\$223,410,000
Total.....	<u>\$614,373,000</u>

While the great proportion of the demand loans were collateral loans, no small part of these were loans to correspondent banks, and the security in such cases was mostly bills receivable. Somewhat more than a third of the time loans were also secured by collateral. Probably more than half of the collateral loans were made to others than members of the stock exchange. The situation, however, was not relieved much by the use of bills receivable as collateral, for no rediscount market existed.

Nor was the situation relieved by direct investment or loaning by the client bank in the stock market. If any country bank through its reserve bank as agent loaned in its own name any of the surplus funds which it had on deposit with the reserve bank, it might earn a greater return than the 2 per cent interest allowed on the balance, but when it called the loan and paid the amount again into its balance, the effect would be exactly the same as if the reserve bank had loaned the balance for its own account. Indeed, it was probable that the New York borrower in paying the direct loan to the country bank borrowed from some other New York bank.

Fictitious Reserves

Another evil of the system of redeposited reserves arose from the fact that the actual available reserve was much less than the minimum reserve required by the banking laws, not only because of the inconvertibility of the call loans as above described, but also because much of the reserve was fictitious. A great deal of the balance carried with the reserve agent was created by remitting checks, drafts, bills of exchange, notes, and collection items in general for collection and credit. If credit was given in advance of actual collection, the country bank gained in reserve balance, but the reserve bank had items that were inconvertible,

at least for a day or so, because it is physically if not financially impossible to secure immediately the cash equivalent of credit items. When the country bank prepared its cash letter and remitted a number of cash items it was a common practice to credit its reserve account; during the day or days this letter was in the mails a discrepancy would exist between its reserve according to its books and its reserve according to the books of its reserve agent. Upon the arrival of the cash letter, credit for the amount either was given immediately to the country bank or was deferred one or more days, according to the contract between the two banks but the too common practice was to give immediate credit. Many of the country banks, however, refused to reciprocate and permit their accounts to be immediately charged with the cash letters sent to them by the reserve bank. Instead they would insist that they be permitted to remit to the reserve bank after the items had been examined and charged to the customers drawing them. The common method of remittance was by draft on the reserve city. The result of these practices was that no small fraction of what were booked as Cash Reserves was afloat in the mail. The amount of this "float" was variously estimated between \$300,000,000 and \$500,000,000.

The inconsistency of the system was further exemplified in the distinction drawn between "gross deposits" and "net deposits." Net deposits were the deposits after certain deductions were made, among which were items in the process of collection; gross deposits included all items tendered by and credited to depositors. The law did not specify against which kind of deposits—net or gross—the per cent reserve should be calculated. It was the practice of the country banks to count the gross deposits with its reserve agent in calculating its reserve balance, but only its net deposits in calculating the amount of reserve required. Against the amount of items in the process of collection, therefore, no reserve was kept, although these items were counted as part of the reserve to support the other deposits.

Evils of Legal Minimum Reserve

Again, objection might be raised against the system on the ground that the fixation by law of a minimum per cent reserve against deposits is very questionable policy. The other governments of the world have left the question of reserve to business expediency. In the older countries with a strong central bank closely affiliated with the government and conscious of its public responsibilities, the plan of voluntary reserves has worked admirably. The tendency in America has been to keep the least possible reserve; as shown above, the banks of New York City in a recent decade barely kept the required minimum. Before the panic of 1907 the trust companies of New York, which were not then directed by law, kept reserves of only 2 per cent, although they were increasingly invading the field of commercial banking. Banks operating under state laws that required only very low reserves uniformly kept only the reserves required. Conservatism and a high sense of public responsibility have not at all times and places characterized our banking class; the force of law may have had the virtue of teaching what the public regards as proper security. The danger of a legal minimum reserve requirement, however, is that the bankers may misinterpret the law and construe it as a command to keep merely reserves to the amount stipulated and no more. As a result the minimum reserve required tends to become the maximum kept, and this has been the experience in the United States.

The reserve is largely maintained in order to instil public confidence in the bank's ability and willingness to pay. If the bank maintains only the minimum required, the slightest run on the bank sends its reserves below the legal limit, and the bank cannot then make use of the reserve for the purpose for which it is kept. Inability to pay out the reserve, by turning suspicion into positive distrust, stimulates the run and often forces a solvent bank with a good supply of gold to suspend. It is like arming a soldier for defense but telling him not to shoot. If a legal mini-

imum reserve is to be required at all, the law should be so drawn as to make this reserve elastic, permitting its use under penalties which would be prohibitive except temporarily in times of emergency.

Decentralization of Reserves

One of the most objectionable features of the former reserve system was the decentralization and parceling of the reserves among the 7,500 national banks and the 21,000 state institutions. The system was positively wasteful of our gold reserves so far as supporting a credit superstructure was concerned. The same size of credit structure as was supported by the gold in the national bank system could have been supported with as great or greater safety by a much smaller amount of gold had that gold been concentrated in a central institution. The seasonal increases and decreases of reserves required would largely balance one another, and the demands of any one section would amount to only a small fraction of the total massed reserves. By this means the central institution would be enabled to extend loans in the direction needed, runs on banks could be abated and deserving solvent banks protected, and the strength of the whole system correspondingly increased. What is essential is that this central reserve-holding institution should hold the reserves in actual cash or in highly liquid form. The object of the federal reserve scheme is to mobilize and concentrate the gold reserves into the federal reserve banks and increase their efficiency.

CHAPTER XXII

RESERVES AGAINST DEPOSITS UNDER THE FEDERAL RESERVE ACT

Legal Requirements

The Federal Reserve Act of 1913 distinguished between time deposits and demand deposits. The reserves required against time deposits in all banks were put at 5 per cent, those against demand deposits in country banks at 12 per cent, in reserve city banks at 15 per cent, and in central reserve city banks at 18 per cent. These amounted to very substantial reductions of reserves, especially against time deposits. The act also provided for a gradual transfer of part of the reserves to the federal reserve banks; the central reserve city banks were to transfer directly $\frac{7}{18}$ of their reserves to the federal reserve bank and to carry $\frac{6}{18}$ in their own vaults; the other $\frac{5}{18}$ might be carried either in their own vaults or in the federal reserve bank. The reserve city banks were, by semiannual payments extending over three years, to transfer reserve money to the federal reserve banks until their reserves were distributed in the proportion of $\frac{5}{15}$ in their own vaults, $\frac{6}{15}$ in the federal reserve banks, and the remaining $\frac{4}{15}$ in either. The country banks by a like process were, after three years, to have their reserves distributed in the proportion of $\frac{4}{12}$ in their own vaults, $\frac{5}{12}$ in the federal reserve banks, and $\frac{3}{12}$ in either. The act therefore purposed to remove the reserve balances formerly carried in reserve city and central reserve city banks and have all the reserves lodged in the banks' own vaults or in the federal reserve banks. If balances were then any longer carried with correspondents in the reserve cities they could not be counted as reserves. These transfers were to be completed by November 16, 1917.

Amendments to Reserve Requirements

On September 7, 1916, the Act of 1913 was amended so as to permit member banks to carry with the federal reserve bank any part of the reserves which by the Act of 1913 they were required to carry in their own vaults. But the members failed to respond to this permission, although they were solicited earnestly to do so by the federal reserve banks. The board accordingly decided to compel the transfer by legislative enactment, secured June 21, 1917. This law simply prescribes the per cent reserve to be held in the federal reserve bank and permits the member bank to keep what till money it finds expedient. The total required reserve of the member banks against deposits is, therefore, carried with the federal reserve bank and consists of a credit balance of 7, 10, or 13 per cent against demand deposits, for country, reserve city, and central reserve city banks, respectively, and 3 per cent against time deposits for all banks wherever located. While this change reduced the reserve requirements still further, it forced the immediate transfer of the portion of the reserves still held with the reserve city banks, the transfer of which was not, by the Act of 1913, to be effected until November 16, 1917. These shiftings in reserves were facilitated by the very easy money conditions caused by the war.

The reserve requirements were further amended in 1918, to provide that banks located in outlying districts of reserve cities, or in territory added to such cities by the extension of their corporate charters, may by the affirmative vote of five members of the Federal Reserve Board maintain the reserve balances prescribed for banks located outside reserve cities; and that banks located in the outlying districts of central reserve cities under similar circumstances may be permitted to hold reserves equal to those required of reserve city banks. The board has voted that it will not define such outlying sections in cities in districts other than Boston and New York, but that it will consider individual applications received from such banks as feel entitled to a change

of reserve requirements. Application is made through and with the recommendation of the federal reserve agent. In New York City the banks of Brooklyn, Queens, Richmond, and the Bronx are permitted to carry 10 per cent under this law; whereas banks located in Manhattan, or located in other boroughs but having branches in Manhattan, carry 13 per cent reserve. This amendment was occasioned by the fact that these outlying banks performed none of the functions of a reserve city bank, or a central reserve city bank, respectively, but occupied the same relationship to the reserve banks as did the provincial banks, and it was thought the reserve requirements ought to be adjusted accordingly.

Amounts and Distribution of Reserves

The amounts and distribution of reserves under the Acts of 1887, 1913, 1917, and 1918, are shown in the table on page 403.

Effects of Federal Reserve System on Reserves

The chief effects of the new system upon reserves held by member banks against deposits may be summarized as follows:

1. Availability and hence reduction of the reserves.
2. Concentration of reserves.
3. Decentralization of bank balances in central reserve cities.
4. Cessation of interest payments.

Each of these advantages will be discussed *seriatim*.

1. Reduction of Reserves

As has been shown, the minimum percentages, particularly against time deposits, have been reduced by the new system. This reduction is warranted for many reasons—because the reserves are now concentrated and rendered more efficient, because they are freed from “float,” because they are located in a central bank which feels its responsibility, and because they are kept in

AMOUNT AND DISTRIBUTION OF RESERVES AGAINST DEPOSITS IN NATIONAL AND MEMBER BANKS

	Central Reserve City Banks	Reserve City Banks	Country Banks
(a) Under the National Bank Act as amended in 1887:			
Amount:			
Against all deposits.....	25%	25%	15%
Distribution:			
Minimum proportion in its own vaults.....	All	½	6/15
Maximum proportion in approved reserve city banks and central reserve city banks.....		½	9/15

Table continued on next page

AMOUNT AND DISTRIBUTION OF RESERVES AGAINST DEPOSITS IN NATIONAL AND MEMBER BANKS
—Continued

	Central Reserve City Banks	Reserve City Banks	Country Banks
(b) Under the Federal Reserve Act, December 23, 1913:			
Amount:			
Against demand deposits.....	18%	15%	12%
Against time deposits.....	5	5	5
Distribution:		After	After
Minimum proportion in its own vaults.....	6/18	12 mo. 18 mo. 6/15 6/15	12 mo. 18 mo. 5/12 5/12
Minimum proportion in the federal reserve bank.....	7/18	3/15 4/15 5/15 6/15 6/15 6/15	2/12 3/12 4/12 5/12 5/12 5/12
May be carried in its own vaults or in federal reserve bank.....	5/18	6/15* 5/15* 4/15* 3/15* 3/15* 4/15*	5/12† 4/12† 3/12† 2/12† 3/12† 3/12†

(c) Under the Amendment of June 21, 1917:			
Amount:			
Against demand deposits.....	13%	10%	7%
Against time deposits.....	3	3	3
Distribution:			
In federal reserve bank.....	All	All	All
(d) Under the Amendment of September 26, 1918:			
Amount:			
Against demand deposits:			
Down-town banks.....	13	10	7
Outlying banks.....	10	7	7
Against time deposits.....	3	3	3
Distribution:			
In federal reserve bank.....	All	All	All

* Or in central reserve city banks.

† Or in central reserve city banks and reserve city banks.

cash form or invested in highly liquid forms. Their availability is unquestioned. The reserves in all twelve federal reserve banks are now available at any one of the twelve, if the Federal Reserve Board is disposed to require one of them to rediscount paper held by another; such rediscounting would decrease the reserve balance of the buying bank and increase that of the selling bank. The till money which formerly counted as reserve is now held in addition to the required reserve, and therefore the change in many banks is probably only nominal.

The actual reductions of the reserves accomplished by the Federal Reserve Act are commonly exaggerated. During the five years preceding the Federal Reserve Act the ratio of the existing reserves that could be considered legal reserves to the net deposits for all national banks ranged from 19.6 to 21.7 per cent. At the same time the ratio of the aggregate lawful money held by the banks to the aggregate net deposits ranged from 12.4 to 13.8 per cent. The system of redeposited reserves therefore made an actual cash reserve of about 13 per cent appear as a legal reserve of about 21 per cent. One dollar of cash then would support about \$8 of deposits.

The ratio of reserves to net deposits for all national banks at the time of the calls of the Comptroller during 1918 and 1919 ranged from 10.02 to 10.46 per cent. One dollar of reserve balance supported about \$10 of deposits for the member banks. The possible expansion of deposits within the legal requirements is not much greater. The federal reserve banks must keep reserves of 35 per cent against their deposits and 40 per cent against their federal reserve notes. One dollar of gold will support about \$2.50 of deposits and notes. But the amount of deposits in the federal reserve banks actually averages about two-thirds of the amount of the federal reserve notes; that is, for every increase of \$3 of notes there is an increase of \$2 of deposits. If, therefore, notes did not increase when deposits increased, \$1 of gold in the federal reserve bank would support $10 \times 100/35$, or about \$29,

of deposits in the member banks; but since in fact, on the average, an increase of \$2 in deposits is accompanied by an increase of \$3 in notes, \$1 gold in the reserve bank will support $\frac{2}{5}$ of \$29, or about \$11.50, of deposits in the member banks. It appears, therefore, that \$1 gold now will support about \$11.50 of deposits, whereas before 1914 it would support \$8. The efficiency of the reserves is therefore increased but little by the lowering of the legal requirements; the fundamental improvement has come by way of concentration of reserves, the issue of elastic notes, and the protection of reserves by discount operations.

2. Concentration of Reserves

The reserves of a member bank now consist wholly of balances with the federal reserve bank. The board has made a steady campaign in the case of both notes and deposits, to concentrate the gold holdings of the system. Laws have been passed by different states permitting their institutions to carry their reserves with the federal reserve banks, and balances are also carried by them with these banks for exchange purposes. Patriotic motives have also favored such concentration. The result is that the board has control of the greater part of the gold of the country. As shown in the statement of the resources of the federal reserve system (page 275) the total reserves carried in cash form equal at least two-thirds of the earning assets. If the federal reserve banks invested a large fraction of these reserves that action would dissipate them again, and the investments could not be considered the equal of cash in the vaults.

3. Decentralization of Bank Balances in Central Reserve Cities

The regional system has the effect of reducing the balances carried in central reserve city and reserve city banks, and of lodging them in the twelve federal reserve banks or of investing them locally. The federal reserve system does not count balances with former reserve agents as reserve; hence, what balances are so

carried reduce by that amount the bank's available funds, and are a source of expense to the bank. Besides, the federal par collection system has largely eliminated the profits from exchange charges that were realized from the old collection arrangements. It is also possible to sell exchange on the federal reserve bank. The existence of a goodly quantity of commercial paper for purchase, as well as the United States Treasury certificates of indebtedness, have provided the member banks with a form of direct investment earning more than 2 per cent. The member banks can rely upon the federal reserve banks for accommodation and no longer have to maintain friendly relations with reserve correspondents for that purpose.

Unless, therefore, the old reserve agents provide additional services, the country banks are tempted to close out their balances with most of their old correspondents. The reserve city banks that have suffered most as a result of the abolition of reserve depositories have been the smaller national banks. The very large banks may have profited by it, for while many out-of-town banks which formerly had a dozen or more New York correspondents have reduced them to one or two, the balances carried with these few are larger than formerly. State bank and trust company members are also inclined to drop their former connections. To hold balances, the reserve city banks have recently been bidding higher interest rates. Most of the clearing houses fixed upon a sliding scale of rates, varying with the market rate for money, or else fixed a maximum rate, payable by any of its members.

Along with this change of relations, it is noteworthy that the New York Clearing House banks give over to the federal reserve banks a goodly part of their responsibility for and guardianship of American finances. Henceforth the clearing house will do less of the extra clearing functions; when in any federal reserve district help is needed by any of the member banks, relief will now be principally obtained by rediscounting at the federal reserve

bank instead of by borrowing from the New York banks. The issue of clearing house loan certificates and the importation of gold by the New York banks to this end will also cease. In case of panic the federal reserve banks, it is hoped, will support the financial world more efficiently than the cumbrous clearing house arrangements of former years.

4. Cessation of Interest Payments on Reserves

The federal reserve banks, conforming to the practices of the central reserve banks of Europe, do not pay interest on reserve balances. To do so would force the central reserve bank to invest an undue proportion of its funds in order to earn a return, and this tying up of the reserves would weaken the reserve position. That was one of the defects of the national bank plan. Though the cessation of interest payments has caused considerable complaint by country banks, there are, nevertheless, certain compensations. One of these is that the reserve requirements have been so much lowered that balances formerly carried with correspondents may be brought home and, on the basis of these balances, large extensions of loans at good rates are made possible. The country banks also have such a highly dependable source of accommodation in the federal reserve banks that they can loan to an amount closer to their minimum reserve limit. The loss on reserve balances may be considered as premium for security against panic.

Calculation of Reserves of Member Banks Against Deposits

For purposes of reserve calculations the Federal Reserve Act defines "demand" deposits as comprising all deposits payable within 30 days. It defines "time" deposits as comprising all deposits payable after 30 days, all savings accounts and certificates of deposit which are subject to not less than 30 days' notice before payment, and all postal savings deposits. Government deposits other than postal savings deposits are exempt from

reserve requirements. (These items are more fully defined by Regulation D of 1917 of the Federal Reserve Board.) In estimating the reserve balances required by law, the net difference between the amount due to other banks and the amount due from them is to be taken as a basis for ascertaining the deposits against which required balances are calculated.

Therefore according to rulings of the Federal Reserve Board on February 11, 1920, demand deposits for reserve calculations consist of: (1) deposits other than United States government deposits and bank deposits payable within 30 days, and (2) the net balance due to banks. The reserve required against the demand deposits is 7, 10, or 13 per cent of the sum of these two items, according to the location of the bank. The net balance due to a bank is ascertained in the following manner: First, are added together these items: the balances due to all banks (including foreign banks) other than the federal reserve bank, deferred credits due to the federal reserve bank, outstanding cashier's, secretary's, or treasurer's checks on the bank itself, and outstanding certified checks. From the total of these items is deducted the total of balances due from banks other than the federal reserve bank and foreign banks, items with the federal reserve bank in process of collection, exchanges for the clearing house, and checks on other banks in the same place as the bank itself. If the aggregate Due from Banks exceeds the aggregate Due to Banks, both amounts are omitted from the calculation. The law does not permit member banks to deduct checks on other banks located in the same place, or exchanges for the clearing house, directly from the gross deposits. The account, Due to Federal Reserve Bank—Deferred Credits, is the one to which items received from the federal reserve bank are credited on the day of receipt if they are to be paid by a charge against the bank's Reserve account; and the account, Due to Federal Reserve Bank—Deferred Credits, will be debited, and the account, Due from the Federal Reserve Bank, Reserve account, will be credited, on the day when these items become a charge

against the bank's reserve account on the books of the federal reserve bank. The general theory underlying these calculations is that demand deposits comprise only deposits which are immediately available, and that items on the liability side whose availability is deferred and uncollected items on the resource side of the bank statement should be disregarded.

The time deposits, for purposes of reserve calculations, consist of the sum of the following items:

1. Savings accounts subject to not less than 30 days' notice before payment.
2. Certificates of deposit subject to not less than 30 days' notice before payment.
3. Other deposits payable only after 30 days.
4. Postal savings deposits.

The reserve required against the time deposits is 3 per cent for all banks. For the purpose of calculating reserves the above items must be reported to the federal reserve bank at stated periods—once a week by member banks located in reserve and central reserve cities and twice a month by country banks.

The balance carried by a member bank with its federal reserve bank may, under the regulation of the Federal Reserve Board and subject to such penalties as may be prescribed by the board, be checked against and withdrawn by the member, but no member bank may at any time make new loans or pay any dividends unless and until the total balance required by law is fully restored. The penalty assessed by the reserve bank on its members for impairment of reserves is to charge interest on the deficiency at a rate above the discount rate.

Definition of Reserve Cities

The Federal Reserve Act conferred authority upon the Federal Reserve Board either to add to the number of cities classified as reserve and central reserve cities, or to terminate their designa-

tion as such. As the reserves of member banks are now carried exclusively with the federal reserve banks, the designation of any city as a reserve city relates only to the percentage of reserve that must be carried by its banks. The question of profits from re-deposited legal reserve balances no longer applies. Since the country and reserve city banks no longer look primarily to the reserve city and central reserve city banks, respectively, for support, but rather to their federal reserve bank, the reason for requiring higher reserves from the reserve city and central reserve city banks is less important; reserves required of central reserve city and reserve city banks are higher than those required of country banks for reasons only that non-member banks keep part of their legal reserves in central reserve city and reserve city banks, and that some member banks also carry non-reserve balances in reserve city and central reserve city banks other than the federal reserve banks.

The reserve cities at present are: Boston, Albany, Brooklyn and Bronx, Buffalo, Philadelphia, Pittsburgh, Baltimore, Washington, Richmond, Charleston, Atlanta, Jacksonville, Birmingham, New Orleans, Dallas, El Paso, Fort Worth, Galveston, Houston, San Antonio, Waco, Little Rock, Louisville, Chattanooga, Memphis, Nashville, Cincinnati, Cleveland, Columbus, Toledo, Indianapolis, Chicago, Peoria, Detroit, Grand Rapids, Milwaukee, Minneapolis, St. Paul, Cedar Rapids, Des Moines, Dubuque, Sioux City, Kansas City (Mo.), St. Joseph, Lincoln, Omaha, Kansas City (Kan.), Topeka, Wichita, Denver, Pueblo, Muskogee, Oklahoma City, Tulsa, Seattle, Spokane, Tacoma, Portland, Los Angeles, Oakland, San Francisco, Ogden, Salt Lake City—63 in all. These cities have now to carry 10 per cent reserve against demand deposits. Boston and Philadelphia, although important banking centers, each having a greater population than St. Louis, continue to be classed as reserve cities and their banks are required to carry but 10 per cent reserve, whereas St. Louis banks must carry 13 per cent.

The Federal Reserve Board has adopted the following requirements as necessary before consideration will be given to the designation of any city as a reserve city: A population of at least 50,000; combined capital and surplus of national banks in the applying city of not less than \$3,000,000, with deposits of not less than \$10,000,000; indorsement of the application by at least 50 national banks located outside of the applying city, stating that they are carrying or intend to carry, if the applying city is designated, accounts with a national bank in the city in question. Applications will be referred for report and recommendation to the federal reserve bank of the district in which the applying bank is located.

Reserves of the Federal Reserve Banks Against Deposits

The Federal Reserve Act requires every federal reserve bank to maintain reserves, in gold or lawful money, of not less than 35 per cent against its deposits. It does not state, except by implication, where these reserves should be actually carried. With the approval of its counsel the Federal Reserve Board has permitted or required the reserve banks to keep portions of their reserves in various places. In 1915, when the gold settlement fund was established, the board required each reserve bank to contribute gold or gold certificates to this fund, and the fund is counted as reserve. A portion of the bank's reserves is also lodged with the federal reserve agents and with foreign banks. The reserve against deposits may be gold or lawful money, whereas the reserve against federal reserve notes must be gold. For deficiency of reserves against deposits the act provides no penalty, and the federal reserve banks have taken advantage of this fact to evade the tax on deficiency of reserves against federal reserve notes.

Nature of the Gold Settlement Fund

One of the objects of the Federal Reserve Act was to provide a universal system of domestic exchange at par. The establish-

ment of such a system has been fraught with great difficulty, both from the complexity of the problem and from the opposition of the country banks; but when it is once in full operation it will stand as one of the great achievements of the federal reserve scheme.

The law of 1913 authorized the Federal Reserve Board as follows:

1. To make rules and regulations governing the transfer of funds and charges therefor among the federal reserve banks and their branches.
2. To exercise at its discretion the functions of a clearing house for the federal reserve banks, or to designate a federal reserve bank which should exercise such functions.
3. To require each federal reserve bank to exercise the functions of a clearing house for the member banks of its district.

Under the power of exercising the functions of a clearing house for the federal reserve banks, the board in 1915 established a clearance fund at Washington, known as the "gold settlement fund." The fund is carried in the Treasury as a special account of the Federal Reserve Board. At the time the fund was originated, each federal reserve bank was required to contribute \$1,000,000 in gold, gold certificates, or gold order certificates, in addition to an amount at least equal to the net indebtedness due to all other federal reserve banks at that date; and each bank is required to keep at all times in this fund a balance of not less than \$1,000,000, and this balance counts as a part of its lawful reserve.

Operation of Gold Settlement Fund

The facilities of the gold settlement fund have been extended to all branches of federal reserve banks which carry deposit

accounts of member banks, thus simplifying the accounting between the head offices and the branch banks. These branches make direct settlements through the fund in the same manner as the federal reserve banks, except that the net debit or credit balance in the settlement of each branch is adjusted through the account of the head office, as the branches do not maintain accounts with the fund.

At the close of business each night each federal reserve bank wires the Federal Reserve Board the aggregate amounts credited that day to each other federal reserve bank. A private wire service is established between Washington and the federal reserve banks, as well as between the banks themselves. On the following morning the board, having received twelve telegrams, charges each sending bank in the gold settlement fund with the aggregate amount stated in its telegram, distributing the individual credits as therein advised. The board then credits each of the twelve banks in the fund with the aggregate of its individual credits telegraphed by the other banks and sends an appropriate telegraphic advice to each bank credited.

Each federal reserve bank, in addition to the telegram to the board, as outlined above, prepares a statement of the details with proper description for the use of each other federal reserve bank whose account in the gold settlement fund had received credit. This letter is proved against the telegram and is then sent by first mail to the board.

The reserve banks, in addition to the daily clearing, have the privilege of demanding transfers at any time when a net debit balance is shown in account with other federal reserve banks.

Deficiencies in the fund are covered either by the deposit of gold, gold certificates, or gold order certificates in the Treasury, or by credit operations, including rediscounts with other federal reserve banks which have an excess balance in the gold settlement fund. A fund similar to the gold settlement fund has been created

for the federal reserve agents, and by it the making of payments not only between federal reserve banks but also between a federal reserve agent and his own bank, is rendered possible without the shipping back and forth of gold or currency.

Functions and Transactions of Gold Settlement Fund

The function of the gold settlement fund is to obviate the necessity of shipping gold—the gold need not be shipped unless the federal reserve bank has exhausted its balance with the fund, and even then shipment may be obviated by credit operations, such as loans or rediscounts.

The fund has particularly facilitated government fiscal operations. The government does business on a money basis, whereas upward of 90 per cent of business transactions are credit transactions; accordingly the government has larger money shipments to provide for than are common to business. The creation of the gold settlement fund and the settlement of inter-regional debts by its means with book credits rather than by shipments of currency have reduced the average amount of money tied up in transit, and have therefore increased the efficiency of the dollar in active circulation.

The transactions commonly put through the fund include the clearance of interdistrict items in the collection system, payments to and from the redemption funds of the federal reserve banks and federal reserve agents, transfers through the federal reserve banks for account of the United States Treasury, etc. The volume of transactions through the fund is greatly increased by heavy gold importations or exportations, fiscal operations of the Treasury, seasonal variations in the need for funds in the different federal reserve districts, rediscounts between the federal reserve banks, the extent to which the banks use the federal par collections system, and other factors. The following table shows the immense growth which has taken place in the volume of transactions put through the fund.

GROWTH IN VOLUME OF TRANSACTIONS PUT THROUGH THE
GOLD SETTLEMENT FUND

(In millions)

	1915	1916	1917	1918	1919	1920
Size of fund on December 31:						
Gold settlement fund, account of federal reserve banks.....	\$ 77	\$ 169	\$ 311	\$ 401	\$ 329	\$ 357
Federal reserve agents' fund.....	56	102	497	928	886	896
Volume of transactions for the calendar year:						
Total clearings.....			24,319	45,439	66,053	85,074
Interbank transfers.....			2,643	4,812	7,930	7,551
Combined.....	\$1,052	\$5,533	\$26,962	\$50,521	\$73,984	\$92,625
Change of ownership of gold.....	96	223	272	238	281	471
Ratio amount of gold changing ownership to total amount of transactions.....	8.14%	4.05%	1.01%	.47%	.38%	.50%

Telegraphic Transfer of Funds

The leased wire system, connecting all federal reserve banks and their branches with each other and with the Federal Reserve Board and the Treasury Department, is used to provide telegraphic transfers of funds for member banks. No charge is made to member banks for such transfers. Through the gold settlement fund it is possible to create without cost any amount of exchange that may be needed at any point where a federal reserve bank or branch is located, as well as to obtain without cost immediate settlement for any amount of exchange that may accumulate there. The funds of each member bank on deposit with its federal reserve bank may be made immediately available in any other federal reserve district by telegraphic transfer at par, free of charge even for the telegram. Exchange charges, which were based upon the necessity of shipping currency, have been eliminated between federal reserve cities now that the necessity of shipping currency has been removed. The account of the sending bank is

charged at the federal reserve bank with the amount of the transfer *from* the reserve bank on the day transmitted, and the member bank is advised of the charge. On telegraphic transfers *to* the reserve bank, the banking institution for whose account the transfer is made is credited on the receipt of the telegram, provided it comes within banking hours, and a letter of advice (or, in case of credit to an out-of-town bank, a telegram) is sent covering the details of the credit. Wire transfers of funds through the federal reserve banks are strictly limited to those ordering payments or credits to banks or bankers. Direct payments by reserve banks to individuals, firms, or corporations are not permitted, but such transfers can be effected through their banks.

Members' Drafts on Federal Reserve Banks

The gold settlement fund is part of the federal reserve scheme whereby federal reserve banks are to acquire, at least in part, the exchange facilities which have been heretofore provided by city banks for their country correspondents, and which were disturbed by the removal of the reserve balances from the city banks to the federal reserve banks. A system of transfer drafts is in operation to facilitate such payments and transfers as do not need to be made by telegraph. It enables any member bank to have its draft drawn upon the federal reserve bank of its own district paid immediately, without time allowance or deduction, at any other federal reserve bank, adjustments between the respective federal reserve banks being made through the gold settlement fund. In this way any member bank has, under the proper and necessary restrictions provided, the same exchange facilities it would have by carrying accounts in each of the twelve federal reserve banks.

Three kinds of drafts may be drawn on the federal reserve banks by members.

1. *Ordinary Drafts.* In making remittances within its own district (that is, in cases in which exchange on another district is not demanded) the member should draw ordinary drafts. Such

drafts are not receivable for immediate availability at par at any other federal reserve bank. In making these remittances it is not necessary to advise the federal reserve bank that the draft has been drawn.

2. *Federal Reserve Exchange Drafts.* These are to be used by the member bank when making remittances of an amount not exceeding \$5,000 outside its district, or in any case where exchange on another district is demanded. These drafts are drawn on the member's reserve bank, and will be receivable for immediate availability at par at any other federal reserve bank, but are actually payable only at the drawee reserve bank. Members are required to forward to their reserve bank a daily mail advice of the numbers, amounts, and totals of these drafts drawn. On receipt of this advice the reserve bank charges the total given therein to the account of the member bank and the funds are held in a special account against which the drafts are charged when presented for payment.

3. *Federal Reserve Transfer Drafts.* These are to be used by the member in making remittances of sums in excess of \$5,000, outside its district, or in any case where exchange on another district is demanded. These must be drawn on the member's federal reserve bank and made payable at one other federal reserve bank designated in the draft. Payment by the other federal reserve bank will be made only upon advice from the drawee reserve bank. Members drawing such drafts must give the drawee reserve bank daily advice of all drafts drawn, and must forward duplicates of the advice to the federal reserve banks at which the drafts are payable. Upon receipt of the advice the drawee reserve bank charges the account of the drawing bank, and provision for meeting the draft is made at the paying bank designated. Transfer drafts are not paid except upon receipt of the duplicate advice and confirmation by the drawee bank.

Member banks drawing federal reserve exchange or transfer

drafts should provide sufficient excess balances with their federal reserve bank to cover the drafts, lest their reserves be impaired, and a penalty be thereby incurred. To effect uniformity of size, text, etc., and to get proper code words, the federal reserve bank supplies the member with blank drafts.

Although the member banks may sell these drafts to their customers under the same terms and conditions as the other drafts and may charge the purchaser, the use of these drafts will not necessarily supplant the use of drafts on correspondents.

The Par Collection System

The second power conferred on the board by Section 16 of the Federal Reserve Act was to require each federal reserve bank to exercise the functions of a clearing house for its member banks. In a circular issued in April, 1915, the board outlined a voluntary reciprocal intradistrict par collection system which was to become effective June 1, 1915. The details were to be worked out by each federal reserve bank to conform to the conditions of the district. The plan met with varying degrees of success in the different districts and after a year of experimentation it was extended into a compulsory intra- and inter-district par collection system. The new system is in essence a country-wide extension of the plan of the Boston Country Clearing House, which had proved, by almost a generation of use, the best and most economical method of collecting checks in a given district.

The printed expression, "Collectible at par through the federal reserve bank," means literally what it says. Though credit may be given at once, the funds are not available as reserve, nor can they be drawn against, until the item has been collected or sufficient average time has elapsed for collecting it. No member bank is required to use the collection system; it has the choice of sending items for collection through the reserve bank regularly, occasionally, or not at all. The reserve bank will receive for collection items on all member banks throughout the United States, and

items on all non-member banks in the United States which can be collected at par; and to this end par lists are published from time to time. The items are handled under uniform protest instructions and all are indorsed to the federal reserve bank. To insure direct routing, the reserve bank reserves the right to return any item drawn on a bank located outside of its district when such item bears the indorsement of a bank also located outside of its district. The items are given immediate credit at par, subject to final payment, but the proceeds are not available for withdrawal and do not count as reserve until the lapse of the average time necessary to send the item and get remittance in return. Schedules of deferment of credit are published, covering credits immediately available and those available after 2, 4, or 8 days.

Items drawn on a member bank are sent to it direct; items drawn on a non-member bank are sent to such members as desire to receive them, or by arrangement direct to the non-member. When time can be saved, arrangements may be made for direct routing between member banks of a certain district, or between members of this and of other districts, or between members of this district and other federal reserve banks.

Member banks may maintain their balances with their reserve bank in the following ways:

1. By depositing exchange on the federal reserve city.
2. By depositing out-of-town items, the proceeds of which will be available as reserve in accordance with the time schedules.
3. By shipment at the expense of the reserve bank of properly sorted lawful money or federal reserve notes.
4. By rediscounting.

Member banks are required to provide funds to cover at par all checks received from or for account of their federal reserve bank, and if any member cannot provide funds otherwise, it is permitted to ship lawful money or federal reserve notes at the

expense of the reserve bank. Penalties are fixed for impairment of reserves, at an interest charge on the deficiency of reserve, say, at 2 per cent above the maximum discount rate.

Until June 15, 1918, the cost of operating the system was borne by the banks using it, the actual cost being assessed monthly on a per item basis upon the banks depositing items. This was called a "service charge." Since that date the service charge has been absorbed by the federal reserve bank. This absorption operates to reduce the dividends of the reserve banks and to distribute the costs on the basis of capital and surplus rather than the actual use made of the system by the member banks.

Progress of Par Collection System

The federal par collection system has been introduced against the continued opposition of the country banks, particularly of the South. The growing use of the system during 1919 and 1920 would seem to augur that it is soon to become universal. Most of the country is now par territory. To get the banks into the collection system the federal reserve banks have used various methods of publicity and persuasion and, in some cases, more drastic means of compulsion. The progress of the collection system and the volume of transactions are indicated in the tables on page 423.

Statistical Statement of Deposits in the United States

On June 30, 1919, the total deposits of the state, savings, and private banks and loan and trust companies in the United States were as follows:

Due to banks.....	\$ 905,000,000
Dividends unpaid.....	10,000,000
Individual deposits.....	20,812,000,000
Postal savings deposits.....	16,000,000
	<hr/>
	\$21,744,000,000

TABLE SHOWING PROGRESS OF THE FEDERAL PAR COLLECTION SYSTEM

District	Number of Member Banks in District June 15		Number of Non-Member Banks on Par List June 15		Number of Incorporated Banks Other than Mutual Savings Banks Not on Par List June 15	
	1920	1919	1920	1919	1920	1919
Boston.....	432	429	254	241		
New York.....	771	734	322	318		
Philadelphia.....	688	667	423	361		46
Cleveland.....	859	825	1,078	833		215
Richmond.....	601	572	766	339	776	1,083
Atlanta.....	437	424	437	329	1,169	1,247
Chicago.....	1,391	1,351	4,239	3,080		1,088
St. Louis.....	563	526	2,511	1,483	174	1,150
Minneapolis.....	967	882	2,906	1,307		1,544
Kansas City.....	1,060	1,002	3,390	2,279		966
Dallas.....	804	744	1,250	301		817
San Francisco.....	793	669	1,038	911		153
Total.....	9,366	8,825	18,614	11,782	2,119	8,309

TABLE SHOWING NUMBER AND AMOUNT OF ITEMS HANDLED BY THE FEDERAL PAR COLLECTION SYSTEM

(In millions)

Month Ending	Number of Items Handled				Amount of Items Handled			
	Drawn on				Drawn on			
	Banks in Federal Reserve Bank and Branch Bank Cities	Banks Outside Federal Reserve Bank and Branch Bank Cities	Treasurer of United States	Total	Banks in Federal Reserve Bank and Branch Bank Cities	Banks Outside Federal Reserve Bank and Branch Bank Cities	Treasurer of United States	Total
1919, July 15	4.9	17.0	2.4	24.4	\$6.4	\$3.8	\$1.2	\$11.4
1920, June 15	7.0	27.5	1.9	36.5	6.7	4.7	0.5	12.8

The deposits of the national banks on the same date were:

Due to federal reserve banks.....	\$ 11,000,000	
Net amounts due to national banks...	1,135,000,000	
Net amounts due to other banks, bankers, and trust companies.....	<u>1,839,000,000</u>	\$ 2,985,000,000
Certified checks outstanding.....		275,000,000
Cashier's checks on own bank outstanding.....		206,000,000
Demand deposits:		
Individual deposits subject to check	\$8,480,000,000	
Certificates of deposits due in less than 30 days.....	409,000,000	
State, county, or other municipal de- posits.....	88,000,000	
Deposits requiring notice, but less than 30 days.....	43,000,000	
Dividends unpaid.....	26,000,000	
Other demand deposits.....	<u>61,000,000</u>	9,106,000,000
Time deposits:		
Certificates of deposit.....	\$ 898,000,000	
State, county, or other municipal de- posits.....	8,000,000	
Postal savings deposits.....	94,000,000	
Other time deposits.....	<u>1,784,000,000</u>	2,785,000,000
United States deposits.....		<u>567,000,000</u>
		<u>\$15,924,000,000</u>

According to the statement of the Comptroller of the Currency covering returns from his call of May 4, 1920, from national banks only, the states ranking highest in the number of deposit accounts per 1,000 of population were as follows:

Wyoming.....	394	Iowa.....	262
Montana.....	349	Virginia.....	259
Idaho.....	293	Vermont.....	255
Pennsylvania.....	289	California.....	248
Colorado.....	280	South Dakota.....	244
Oregon.....	275	Maine.....	239
Minnesota.....	271	Texas.....	236

At this date there was an average of 190 accounts for each 1,000 people, or approximately one account for every $5\frac{1}{2}$ people. The number of demand deposit accounts was 12,315,000, and of time deposit accounts 8,065,000, aggregating 20,380,000 accounts.

CHAPTER XXIII

INSTITUTIONS OTHER THAN NATIONAL AND FEDERAL RESERVE BANKS

Composition of the Banking System of the United States

In Chapter XII were listed, under several classifications, the financial institutions that compose the banking system of the United States. The intervening chapters have described the national and federal reserve banks. In this and the succeeding chapter will be treated the other financial institutions of the country, but not with the fulness given to the national and federal reserve banks. Many of these other institutions are largely divorced from commercial banking, which this book aims to present; many are closely concerned with the investment market, some with savings, some with personal loans, some with building homes; only indirectly do these affect commercial banking. They are, however, an essential part of our banking system and warrant proportionate treatment. State banks and trust companies are largely commercial banks, and they are very numerous and important.

State Banks—Growth

State banks, which include commercial banks incorporated under state charters, amounted in 1860 to 1,562. By 1868 this number had decreased to 247 owing to national bank legislation, particularly the 10 per cent tax on circulation. After 1870 they again began to increase. The state banks developed without regulation because the issue of bank notes was impossible and the regulation of deposit banking was not regarded a duty of the government until some time after the national bank system had led the way. In recent years the individual states have undertaken

the general supervision of the financial institutions within the States.

In certain states constitutional prohibition delayed the growth of state banks. The state of Texas retained such prohibition longest—until 1905. In practically every state the incorporation of banks was hedged about with limitations, such as referendum of all banking laws, a two-thirds vote for the enactment of banking laws, and incorporation by special legislation rather than general laws. The general tendency has been to liberalize incorporation by means of general banking acts as distinguished from business incorporation laws.

Requirements as to Capital

Most states have requirements as to the minimum capital of their banks. In some states the amount required is the same throughout the state; in others the amount is either graded according to the population of the domiciling city, or varies with the business done by the bank. The minimum capital required ranges from \$5,000 to \$50,000, the banks in the eastern and east middle states having the largest. Since the national banks up to 1900 had to have \$50,000 or more capital, and \$25,000 after that date, the smaller banks were obliged to take out state charters. For this reason state banks are more ubiquitous. The adjustment of capital to population serves roughly to make the responsibility of the stockholders vary with the size of the banks, and also puts a check on excessive competition.

The states also vary in their requirements as to authorized, subscribed, and paid-in capital. There is a tendency, however, to follow the national bank system in this respect and to shorten the period within which capital must be fully paid. Most states require the accumulation of a surplus equal to 20 per cent of the bank's capital. The tendency is to require larger surpluses and faster accumulation of them. The declaration of dividends except out of net earnings is usually prohibited, and some states

provide elaborate rules for the calculation of net earnings. Most states follow the National Bank Law of 1873 and provide for the assessment upon stockholders of any impairment of capital. Since most states require stock to be fully paid, the liability for unpaid subscriptions is unimportant. There is a tendency also to impose a "statutory liability" upon stockholders beyond the stock held by them, usually a double liability.

Limitations as to Loans

Since most of the banks in the United States are small, the loans to any one customer are likely to involve excessive concentration of risk. This danger is increased by the fact that a controlling interest in the bank may be and often is owned by one person, firm, or corporation engaged in other business. The limitation on national banks in this respect is that the loans to any one person shall not exceed 10 per cent of the bank's capital and surplus and 30 per cent of its capital, but "the discount of bills of exchange in good faith against actually existing values and the discount of commercial or business paper actually owned by the person negotiating the same" is not considered as money borrowed. Most states have some limitations, modeled upon the National Bank Law, on loans to any one person, the variations ranging from 10 to 30 per cent of capital, or of capital and surplus, or of capital and surplus and undivided profits. Practically all states make the same exceptions with respect to discounted paper as do national banks and many of the states make additional exceptions, particularly as to loans on real estate, bills of lading and warehouse receipts, collateral securities, and loans approved by special vote of the directors. Loans to directors and officers are likely to be excessive and on slight security, and while the National Bank Law makes no provision against such loans, many states require that they either must be approved by an appreciable majority of the board of directors, or must not exceed certain specified maximum amounts, or must be specially secured.

In almost all of the states, loans may be made on real estate security, but up to 1913 national banks were prohibited from making such loans and some restrictions are still made by some states as to population of city, amount of loan, margin of value of security, character of lien, and the kind of bank empowered to lend on real estate security. This kind of loan is non-liquid and dangerous for a commercial bank, but the power to loan in this way has been very useful to state banks. Because of their greater freedom in extending loans, the state banks have been able to adapt themselves to local conditions more than have national banks.

Requirements as to Reserves, Branches, and Supervision

Regulations as to minimum reserves against deposits were, even in those states where such reserves are now required, very tardily made, Connecticut leading the way in 1872. The requirement is not yet regarded as important in many states where regulation is directed chiefly to matters affecting directly the safety of the individual bank. Recently most of the states have made some regulations as to reserves, differing among themselves as to amount, form, and enforcement of the requirement. Some states require the same amount of reserve for all classes of deposits, others require different amounts against the different classes; and still others require reserves only against demand deposits. In some states the reserve must be held in cash or bank balances, in others it may consist in whole or in part of securities. In nearly every state bank laws allow the redeposit of reserves only in banks inside the state, although in some states the law designates certain cities outside the state, such as New York, Chicago, etc., where reserves may be redeposited.

Branch banking has not developed greatly in any of the states. State banks, like national banks, are decentralized and locally owned. Certain states forbid the opening of branches; others do not provide for them; others definitely permit them. If they are

permitted, additional capital for each branch and special authorization by the banking department are usually required. In some states, a bank, denied branches, may own stocks in other banks or trust companies. Until forbidden in 1908, New York trust companies operated state banks, trust companies, and national banks in this manner. Another method is the ownership by a person, a group of persons, or a holding company, of a controlling interest in several banks or trust companies. This is called "chain banking," and is devised often by promoters to finance their undertakings. This has been limited in some states by limitations of loans on stocks of "moneyed corporations" to 10 per cent of the capital of the corporations whose stock is thus offered as collateral.

Supervision over state banks by special bank commissions arose after 1887. Before that time the banks in certain states made annual reports to some state official. Practically every state now requires reports, and many require yearly several reports of various kinds. The reports are made at the call of the bank supervisor, and are usually timed to agree with the calls of the Comptroller of the Currency. Regular bank examinations started in the New England states, and most states now provide for one or more regular examinations each year as well as special examinations of particular banks. The cost is usually assessed in whole or part on the examined bank. The states also tend to require regular bank examinations by the bank directors. The states put the execution of their banking law into the hands of a superintendent, or commissioner, of banks, whose powers and duties vary widely. Harmony of supervision and uniformity of law are being achieved through the National Association of the Supervisors of Banks. In general, the officials pass upon applications for charters, handle insolvent banks and violations of law, appoint receivers or liquidate failed banks, conduct examinations, call for and publish report, etc. The powers of the supervisors have grown gradually in number and extent.

Trust Companies—Legal Requirements

As stated in Chapter XII, trust companies perform numerous functions. Their powers vary with the state laws, and to the general power of administering trusts incidental or even unrelated powers have been added. The trust companies are becoming more and more standardized as to lines and operations. There is a tendency among them to drop title and fidelity insurance business and to develop their commercial banking activities, so that the businesses of the trust companies and the commercial banks are approximating each other. Some states no longer distinguish between the institutions, but rather regulate their business as divided into three classes—commercial banking, savings banking, and trust operations.

The legal requirements as to capitalization of trust companies follow very closely those for banks. The minimum required capital for trust companies was originally higher than that for banks, but now tends to equal it. The provisions limiting the amount of any single liability generally apply to both banks and trust companies. The same is true as to reserve requirements; only a few states require reserves for banks but exempt trust companies. Where differences are made they are usually not substantial. As contrasted with banks, trust companies may more often count securities as reserve and may keep different amounts against time and demand deposits. The panic of 1907 led to legislation in certain states raising the amount of reserves required for trust companies.

Growth of Trust Companies

The early companies, of which the first was founded in 1822, were also interested in the insurance business. In 1853 the first company was chartered to do exclusively trust business. Immediately after the Civil War the real trust company movement began, and when the Comptroller of the Currency began in 1875 to make his annual reports, 35 companies handed in statements

to him. The list was incomplete, for the statements were voluntary and many companies did not make them. The rate of growth was rapid, between 1890 and 1900 almost doubling, and between 1900 and 1910 almost trebling. By 1909 the individual deposits of the trust companies, as well as their total resources, exceeded those of the state banks. The competition of the trust companies with the state and national banks was most intense at the time of their rapid expansion, between 1900 and 1915. The comparative growth of the various kinds of banks is shown in the table on page 433.

Causes of Recent Growth

The trust companies owe their recent rapid growth to several factors. Probably the greatest is the tremendous increase in private and corporate wealth in the last generation. The need for some institutions to care for these large private estates and assist corporate financing promoted the trust company. The trust company has been highly useful in assembling funds for corporate investment, and, in conjunction with investment houses, in directing our industrial development. Its wide range of powers has also attracted customers, for it is able to serve practically every financial need of the private person or corporation; the customer is thus relieved from dealing with different parties and dividing his account. The trust companies have found it possible to pay better rates of interest on deposit balances than have the commercial banks, and this has been a powerful magnet for accounts. As they have been subject to less state legislation, regulation, and taxation, they have had fewer expenses and greater freedom in profit-making.

Another contributory cause of the rapid growth of trust companies was their freedom at one time from regulation as to the minimum reserve kept. They carried practically their whole reserve on deposit with other banks. The accompanying table¹

¹Herrick, Trust Companies. New York, Bankers Publishing Company, 1915, p. 26.

RELATIVE GROWTH OF BANKS AND TRUST COMPANIES IN THE UNITED STATES*

(Resources in millions)

DATE	LOAN AND TRUST COMPANIES		STATE BANKS		MUTUAL SAVINGS BANKS		JOINT-STOCK BANKS		NATIONAL BANKS		PRIVATE BANKS	
	Number	Resources	Number	Resources	Number	Resources	Number	Resources	Number	Resources	Number	Resources
1875	35	\$ 122	551	\$ 272	674	\$ 896††	2,076	\$ 1,913††
1880	30	126	620	354	629	881††	2,076	2,035††
1885	40	248	975	553	646	1,203††	2,689	2,421††
1890	149	503	2,101	870	637	1,486	284	\$ 255	3,484	3,061	1,344	\$164
1895	242	807	3,774	1,147	664	1,756	353	297	3,715	3,470	1,070	130
1900	290	1,330	4,369	1,759	652	2,336	350	288	3,732	4,944	989	126
1905	683	2,865	7,794	3,190	668	2,967	569	400	5,668	7,327	1,028	165
1910	1,091	4,216	12,166	3,964	638	3,652	1,121	829	7,145	9,896	934	160
1915	1,664	5,873	14,598	4,399	630	4,319	1,529	1,238	7,605	11,795	1,036	177
1919	1,377	7,959	17,225	11,701	622	5,171	1,097	1,281	7,785	21,834	1,017	266

* Reporting to the Comptroller of the Currency at his call, about June 30. These figures for other than national banks, particularly in the earlier years, are not exact, for the Comptroller had to depend upon voluntary reports and such unofficial sources as he might find.

† Counted in with the state banks.

‡ Not reported.

shows that the reserve ranged from 15 to 27 per cent, but that the cash actually kept on hand by the trust companies ran as low as 2 per cent against total deposits, at the time of their most rapid development. After the panic of 1907 the ratio of till money to deposits was raised, both by law and voluntarily from proved business expediency.

RESERVES AND CASH ACTUALLY KEPT ON HAND BY TRUST COMPANIES

Year	Reserve	Till Money	Year	Reserve	Till Money
1890	15.7%	5.9%	1902	17.2%	2.2%
1891	15.8	4.6	1903	17.7	3.0
1892	18.7	5.4	1904	24.9	3.6
1893	15.4	4.5	1905	18.2	3.1
1894	26.1	7.2	1906	17.0	3.7
1895	23.2	6.5	1907	16.6	4.9
1896	18.3	4.9	1908	25.4	6.1
1897	20.5	5.1	1909	27.4	8.8
1898	17.8	3.4	1910	23.1	8.8
1899	18.5	2.9	1911	25.2	8.0
1900	21.3	2.9	1912	23.6	8.4
1901	17.0	2.0	1913	23.0	8.6

Supervision and Regulation

The examination and regulation of trust companies developed later than the examination and regulation of banks. This was due to the late standardization of trust companies and was brought on by the invasion of the field of commercial banking. To the degree that trust companies devote themselves to commercial banking they should be subject to the same restrictions and regulations as the competing commercial banks. The interdependence of all financial institutions upon each other, particularly in times of panic, and the danger arising from reckless competition between trust companies and banks, warrant the

state legislatures in providing for as severe supervision over the one kind of institution as over the other. The supervision of the trust companies devolves upon the superintendent of banks.

Herrick² presents data to show that trust companies have a fair record as to failures compared with other financial institutions. The comparison lacks exactness, it is true, for the data are not complete, but it is probably as accurate as can be determined.

TABLE SHOWING COMPARATIVE FAILURES OF THE VARIOUS TYPES OF FINANCIAL INSTITUTIONS

	Suspensions		Average Number of Banks	Percentage of Failures to Average Number of Banks
	Total (21 years)	Per Year		
National banks...	386	18.4	5,039	.36%
State banks.....	676	32.2	7,400	.43
Savings banks....	178	8.5	1,290	.66
Trust and loan companies.....	106	5.0	1,000	.50

The actual losses to depositors have been small indeed, for many of the suspended companies resumed payments later, and others were able to liquidate their debts at par. There is a common, unchallenged statement that not a dollar of trust funds has ever been lost through a trust company.

Private Bankers

The term "private banker" has come to represent two categories in the United States. In Wall Street it technically refers to a small group of great banking houses, such as J. P. Morgan and Company, J. and W. Seligman and Company, Kuhn, Loeb and Company, August Belmont and Company, Brown Brothers and Company, and a few others. These houses do an

² *Op. cit.* p. 23.

international as well as a national business. They have branches in the leading foreign financial capitals, or have as their representatives the most powerful banking houses in those places; and in turn they are the representatives of the great foreign houses like the Rothschilds, and also of foreign governments and big corporations. In the other financial centers of the United States they own branches or are closely allied, by partnership, stock ownership, or community of interest, with the strongest banking houses.

The private bankers transact a general banking business much the same as the incorporated banks do, but free from many of their limitations. They make call and time loans, buy and sell mercantile paper, and engage extensively in all foreign exchange operations. They act as fiscal agents for corporations and associations. They are dealers in investment securities. They often conduct important operations in the stock market. They underwrite new issues of stocks and bonds for railroad and other corporations. They undertake the reorganization of insolvent or embarrassed railroads. Of recent years they have been especially prominent in the promotion of immense industrial companies. They are at once bankers, brokers, dealers in foreign exchange, promoters, organizers, and underwriters. . . . The deposits and corporate connections of two or three of these private banking houses make them rank with the most powerful banking institutions in the world.

Their field of operations is, indeed, as wide as the world. Their business in London and Paris and Berlin is almost as much as it is in New York. . . . The private bankers are intimately connected with and influential in the railroad and the big industrial corporations which engage in the principal branches of trade.³

On a few occasions these banking houses have come to the support of the national Treasury, as for instance, the Morgan-Belmont Syndicate in 1894-1895; they also have been active in relief in times of panic.

The term "private banker" also applies to smaller houses scattered throughout the United States which do a more or less

³ Pratt, Sereno S., *The Work of Wall Street*, 1914, pp. 340-341.

diversified banking and financial business. The Comptroller of the Currency estimates that there are approximately 3,500 private banks in the United States, and of these he was able in 1919 to gather statistics of only 1,017. Originally none of the private banks were under the supervision of the state; more recently many of the states have subjected them to some supervision; and some states have forbidden the establishment of any new houses of the kind except as they submit to state supervision. As many of them are outside the supervision of the state, the Comptroller of the Currency must depend upon voluntary reports from them. The result is that data upon them are very incomplete.

Most of these houses are proprietor or partnership organizations, and are therefore not corporate creatures of the state and are outside the corporate law. Hence they enjoy a wider latitude in their operations and are subject to less interference from the state. They determine their own reserve requirements and their own limitations on loans; they depend upon the confidence of the financial world in their abilities, skill, and judgment, and not upon the regulation of the state. Some states, in order to protect the state banks and trust companies and to protect the public against bad banking, have set nearly as severe restraints upon private bankers as upon others.

Mutual and Joint-Stock Savings Banks

The earliest savings banks were founded in Philadelphia in 1816, in Boston in 1816, in Baltimore in 1818, and in New York in 1819. These were of the mutual type.

The growth of mutual and joint-stock savings banks is indicated by the figures⁴ in the table on page 438 for the census years.

The most rapid growth appears in the decade 1900-1910. Between 1910 and 1919 the deposits of the savers increased from

⁴ Taken from the Report of the Comptroller of the Currency, 1919, Volume I, pp.167-168.

TABLE SHOWING GROWTH OF MUTUAL AND JOINT-STOCK SAVINGS BANKS

Year	Number of Banks	Number of Depositors (In millions)	Deposits (In millions)	Average Due Each Depositor	Average per Person in the United States
1820	10	8	\$ 1	\$131.86	\$.12
1830	36	38	6	183.09	.54
1840	61	78	14	178.54	.82
1850	108	251	43	172.78	1.87
1860	278	693	149	215.13	4.75
1870	517	1,630	549	337.17	14.26
1880	629	2,335	819	350.17	16.33
1890	921	4,258	1,524	358.03	24.35
1900	1,002	6,107	2,449	401.10	31.78
1910	1,759	9,142	4,070	445.20	45.05
1915	2,159	11,285	4,997	442.83	49.91
1916	1,864	11,148	5,087	456.31
1917	1,807	11,366	5,417	476.60
1918	1,819	11,379	5,471	480.79
1919	1,719	11,434	5,902	516.18

\$4,070 million to \$5,902 million, or 45 per cent. During this decade, however, the price level and cost of living increased 108 per cent (Bradstreet), and therefore the savers have suffered despite their thrift, since their savings, including the increases by interest and additional deposits, have decreased in purchasing power.

A comparative statement based on the Report of the Comptroller of the Currency, 1919, Volume I, pp. 209-210, of the use made of savings banks in various leading countries is given in the table on page 439.

From this it appears that the use of the postal savings banks in the United States is very meager compared, absolutely and relatively, with the use in other leading countries, and that we rank low in the relative proportion of our people who have savings bank deposits of any kind. On the other hand, it appears that our individual accounts (probably reflecting the difference in standards of living) are very much larger than in any other

**COMPARATIVE STATEMENT OF USE MADE OF SAVINGS BANKS
IN THE LEADING COUNTRIES**

Country	Savings Bank	Number of Depositors (In millions)	Deposits (In millions)	Average Deposit Account	Average Deposit per Person
France.....	Private	85	\$ 3	\$ 34.92	\$.90
	Postal	1,922	591	74.64	14.93
Germany.....	Public and corporate	27,205	5,105	187.68	76.53
Italy.....	Communal and corporate	2,473	491	198.71	13.45
	Postal	6,472	431	66.73	11.82
Japan.....	Private	9,705	99	10.29	1.79
	Postal	13,893	154	11.14	2.78
United Kingdom.	Trustee	2,015	261	129.84	5.99
	Postal	14,746	957	64.90	21.92
United States...	Postal	565	167	295.88	1.57
	Mutual and joint-stock	1,434	5,902	516.19	55.30

country and that our per capita savings are second only to those of Germany.

The distribution of the mutual savings banks shows a high concentration in the North and East. The figures in the table on page 440 show the situation on June 30, 1919.

The statistics of the joint-stock savings banks are less useful for the reasons that in many states they are included with the state banks, and in others (New Jersey and Minnesota) with the mutual banks. Of the 1,097 joint-stock savings banks reported by the Comptroller, 926 were in Iowa.

Statistical Statement of the Banking System of the United States

In order to summarize the figures for the six chief classes of banks in the United States, and therefore to give a comprehensive view of our financial power, the following statistical statements are given. These figures are, of course, not inclusive of our complete system, as figures for the federal reserve banks, federal farm

TABLE SHOWING DISTRIBUTION OF MUTUAL SAVINGS BANKS,
JUNE 30, 1919

State	Number of Banks	Deposits (In millions)	State	Number of Banks	Deposits (In millions)
Maine.....	44	\$ 97	New York.....	141	\$2,179
New Hampshire....	45	45	New Jersey.....	27†	173
Vermont.....	20	59	Pennsylvania.....	10	279
Massachusetts.....	196	1,089	Delaware.....	2	17
Rhode Island.....	15	101	Maryland.....	17	116
Connecticut.....	80	387			
New England states.....	400	\$1,845	Eastern states....	197	\$2,765
Ohio.....	3	\$ 65	Washington.....	1	\$ 9
Indiana.....	5	14	Pacific states.....	1	\$ 9
Wisconsin.....	7	3			
Minnesota.....	9*	46	Total United States.	622	\$4,751
Middle Western states.....	24	\$129			

* Includes two state banks.

† Includes one state bank.

loan system, the building and loan associations, the Morris-plan banks, the remedial loan associations, etc., have been omitted, since the inclusions of such figures would probably be more confusing than helpful. Moreover, the statistics concerning these last-named institutions are not as complete as those on the six principal classes of banks. The figures have been gathered by the Comptroller of the Currency, who must in certain cases depend upon voluntary reports from the state and private institutions; hence these data are not absolutely full and complete.

SAVINGS BANKS

441

STATISTICAL STATEMENT OF BANKS IN THE UNITED STATES, JUNE 30, 1919

	National Banks (Nov. 17, 1919)	State Banks	Mutual Savings Banks	Stock Savings Banks	Loan and Trust Companies	Private Banks	Total
Number of banks.....	7,865	17,225	622	1,097	1,377	1,017	29,203
<i>Assets</i>							
Loans and Discounts.....	\$11,583	\$ 6,703	\$2,335	\$ 778	\$4,091	\$153	\$25,643
Investments.....	4,865	2,279	2,491	295	2,069	41	12,044
Banking House and Realty.....	381	274	59	36	180	14	944
Due from Banks.....	3,796	1,574	189	129	850	43	6,491
Checks and Other Cash Items.....	77	319	1	3	198	1	599
Exchanges for Clearing House.....	919	919
Cash on Hand.....	450	355	35	31	142	7	1,020
Other Resources.....	458	195	56	5	426	4	1,144
Total.....	\$22,445	\$11,701	\$5,171	\$1,281	\$7,960	\$266	\$48,823
<i>Liabilities</i>							
Capital Paid In.....	\$ 1,153	\$ 785	\$ 62	\$ 450	\$ 19	\$ 2,469
Surplus and Undivided Profits.....	1,456	604	\$ 398	47	588	13	3,116
Due to Banks.....	3,371	444	1	455	3	4,274
Deposits.....	14,097	9,015	4,751	1,151	5,702	216	34,932
Rediscounted Items.....	680	109	113	902
Bills Payable.....	1,061	303	1	6	275	5	1,651
Bank Notes.....	680	680
Other Liabilities.....	617	436	19	10	375	7	1,484
Total.....	\$22,445	\$11,701	\$5,171	\$1,281	\$7,959	\$266	\$48,823

TABLE GIVING THE GEOGRAPHICAL DISTRIBUTION OF THE NATIONAL BANKS AND OF THE STATE INSTITUTIONS, JUNE 20, 1917

(Resources in millions)

GROUP	NATIONAL BANKS		STATE BANKS		MUTUAL SAVINGS BANKS		JOINT-STOCK SAVINGS BANKS		PRIVATE BANKS		LOAN AND TRUST COMPANIES	
	Number	Resources	Number	Resources	Number	Resources	Number	Resources	Number	Resources	Number	Resources
New England	403	\$ 1,166	6	\$ 15	404	\$1,892	10	\$ 11	273	\$ 1
Eastern	1,643	6,759	518	1,239	197	2,721	51	53	117	\$ 25	561	55
Southern	1,580	1,801	4,582	1,198	1	1	59	63	42	6	287	2
Middle Western	2,111	4,137	5,659	2,680	19	124	898	364	728	147	399	4
Western	1,328	1,157	4,194	902	31	12	47	17	62
Pacific	535	1,121	1,064	637	1	69	136	622	2	26
Total*	7,604	\$16,151	15,968	\$6,799	622	\$4,811	1,185	\$1,127	936	\$197	1,608	\$64

* The totals include the banks of Alaska and Hawaii, not here separately specified.

CHAPTER XXIV

INSTITUTIONS OTHER THAN NATIONAL AND FEDERAL RESERVE BANKS (Continued)

Postal Savings Banks

The postal savings banks were inaugurated in 1910 as a device to give greater security to small depositors and attract deposits from hoarding, particularly by the foreign and other elements of our population which tend to be suspicious of banks. The "control, supervision, and administration of the postal savings depository offices" and of the deposits received are conferred upon a board of trustees consisting of the Postmaster-General, the Secretary of the Treasury, and the Attorney-General, representing the administrative, financial, and legal aspects of the system.

Accounts may be opened by any person ten years of age or over, and deposits made in sums of \$1 or multiples thereof. The amount which any depositor may deposit in his interest-bearing account is \$2,500 and accumulated interest, and in his non-interest-bearing account, \$1,000. The purpose of some of these restrictions is to keep these banks from competing with the state savings banks. Petty savings are encouraged by a scheme of postal savings stamps redeemable in sums of \$1. Deposits may be withdrawn on demand and paid by postmasters out of their daily postal receipts and out of a small working balance carried by them in neighboring banks. If this emergency credit proves insufficient, the postmaster communicates with the board of trustees, who may defer payment until the necessary funds are on hand. The United States Treasury maintains for this purpose a 5 per cent cash reserve fund against all deposits. The system is highly decentralized, the local postmaster keeping the records of individual accounts, crediting deposits and debiting withdrawals.

The rate of interest is fixed by law at 2 per cent. This rate removes the system from competition with existing banks and makes it possible to loan out the funds at a profit, thereby making the system self-sustaining and a feeder of other banks. The funds are divided into three parts: (1) the 5 per cent reserve fund kept in the Treasury; (2) a sum, not exceeding 30 per cent, which may be invested by the trustees in bonds or other securities of the United States; and (3) the remainder, which is kept on deposit in solvent banks, state or national. The funds deposited in banks are to bear interest at $2\frac{1}{4}$ per cent, to be secured by qualified securities, and to be distributed among applicant banks of the same locality, if there are any, on the basis of their capital and surplus. Any depositor of postal savings funds may surrender his deposit, or part of it, in sums of \$20, \$40, \$60, \$80, \$100, and multiples of \$100, and receive in exchange $2\frac{1}{2}$ per cent United States bonds of these denominations, redeemable one year from date and payable in twenty years. The bonds may be issued only to refund other bonds, or when, according to law, the government wishes to issue bonds to replenish the Treasury.

On June 30, 1919, deposits reached \$167,323,260, the number of depositors was 565,509, and the average principal per depositor \$295.88. The postal savings funds were held by 5,211 banks, of which 3,239 were national banks, 1,161 state banks, 271 savings banks, 531 trust companies, and 9 private banks under state control. The board of trustees had invested \$5,288,600 in postal savings bonds, purchasing them from the holders at par, and \$23,965,300 in Liberty bonds, par value \$25,000,000; they carried with the depository banks \$135,732,031, and with the postmasters \$282,490. The geographical distribution of postal savings deposits approximates closely to the distribution of the population, particularly of the foreign elements. The rank of the leading states, in million-dollar terms, is as follows: New York, 58.4; Pennsylvania, 20.7; Illinois, 11.1; Ohio, 9.9; Michigan, 7.7;

Massachusetts, 6.4; Washington, 5.2; Connecticut, 4.4; California, 3.9. An annual statement of the Postmaster-General purports to show that the postal savings system is self-supporting, but the inadequacy of the accounting system of the post-office renders such statements mere guesses.

Postal savings have not developed in the United States to the extent the advocates of the system anticipated. Either the volume of funds hoarded was exaggerated, or else the savings system has not proved attractive enough to draw them forth. Other savings institutions with their wide-spread development, and quite recently war savings stamps and certificates, seem to absorb the bulk of the savings of the people.

School Savings Banks

The school savings bank plan was originated in 1876. In 1915 the American Bankers' Association began an active campaign to put savings banks into the public schools and inculcate the habit of economy in the minds of the young. Banks in various cities have co-operated by supplying the initial expense money and offering certain services. The Board of Education of New York City created the office of Supervisor of School Banks in its Bureau of Audits and Accounts. The duties of the office are to encourage thrift among children and parents, to enlighten the people as to the purposes and advantages of school banks, to install new banks and instruct teachers in charge of the work, to get the co-operation of the savings banks, to obtain uniformity and efficiency in audit and school reports, to prepare reports on condition and progress for the Board of Education, and to make suggestions for improvement and provide for future growth.

The banks are usually installed in the basements of the school buildings and are equipped with fixtures resembling those of regular banks. Deposits are received usually twice a week, before and after school hours. The work of the various departments of the bank is co-ordinated with the classes in English, advertising,

drawing, salesmanship, and statistics. Regular officers whose duties resemble those of the officers of regular savings banks are elected from the senior class. Every student serves in each of the departments during his school life.

Albany, Rochester, Detroit, Chicago, Minneapolis, San Francisco, Kansas City, Pittsburgh, Harrisburg, Paterson, and other cities have systems in operation. In certain states the state universities and bankers' associations are acting as propagandists of the idea. Various states have passed laws correlating these school savings banks and the local savings banks.

Building and Loan Associations—Nature and Organization

Building and loan associations include associations variously called mutual loan associations, homestead aid associations, savings fund and loan associations, co-operative savings and loan associations, co-operative banks, building societies, etc. They have slight variations, but in general they aim to furnish a safe means for the accumulation of savings and an opportunity to borrow money at reasonable rates for the purpose of building homes.

The associations are extremely local in character and without centralization. The members of an association are confined to a community or county, and the social element is an important principle in their success. There were in the United States in 1918 some 7,484 associations, with 4,011,401 members, and assets of \$1,898,000,000. Though some of these associations are members of the United States League of Local Building and Loan Associations, they retain their local character and independence. There is a negligible number of national associations which draw their members from the country at large, but they are not very successful.

These societies differ from mutual savings banks among other ways in that they are less paternalistic in origin and support, being founded and run not by philanthropists of the upper class

but by members themselves. They are ordinarily founded by some lawyer, merchant, saloon-keeper, teacher, or able workman, from self-interest, or for social or humanitarian motives. The usual officers are a president, board of directors, and a secretary-treasurer. The secretary-treasurer does practically all the work, and he alone receives a salary. A property committee passes upon the security for loans. Most of the states now provide for periodic auditing of, and reports from, such societies.

Operations and Functions

The associations are capitalized, the members paying a certain sum weekly or monthly until the aggregate amount paid plus accrued interest equals the maturing value of the share, usually \$200. Thus the capital of the association is derived from the savings of its members and is increased from month to month. By the Philadelphia plan new series of stock are issued each year. These are paid for by weekly or monthly instalments, the amount of the instalment depending upon the face value of the share and the time until it matures. By issuing shares of varying values and durations the dues can be adapted to all sorts and conditions of people, running as low as \$1, or 50 cents, or even 25 cents a week. A person may join at any time by paying the back dues on any shares of the series. A share is given two values: (1) the holding value, which is its actual value, and (2) the withdrawal value. If a member withdraws before the share matures he gets the withdrawal value, which is less than the share's actual value, and by this system of penalties regularity and method in saving are promoted. The Dayton plan also permits new members to enter at any time, but it does not require the new member to pay the back dues on his share and issues a new share with maturity date based upon the entrance date. The Dayton plan does not impose penalties for withdrawal before maturity.

A stockholder may borrow from the association an amount not to exceed the actual value of his stock, if he can give satisfactory

security. When the association accumulates, by payments of dues and interest, an aggregate amount large enough to loan, it is loaned to that member who offers at auction the highest bonus or premium plus the regular interest, the interest being paid along with his dues. At maturity the share of stock which then becomes the property of the association is used to extinguish the principal of the loan. Such a system provides for collective lending and individual borrowing; collective borrowing is not a usual feature.

The system furnishes a concrete training in thrift, with the ideal of owning a home. It offers high rates of interest to lending members; for the association's expense is very low, having to pay no rent and few salaries. It lends small amounts to borrowers on more favorable terms than they can obtain elsewhere, and allows repayment in weekly instalments. To withdraw from the system is easy, incurring little or no penalty. The system gives a social solidarity to the community and reduces the mobility of the population.

In the future probably the aid given toward home-owning will form a less important feature of the system, for to own a home is coming to be regarded among workingmen as a doubtful economy.

Statistical Summary

The first building and loan association was founded in Philadelphia in 1831. Pennsylvania has always led in the movement, and its associations of this kind have defeated the rise of mutual savings banks in that state. On the other hand, in New England mutual savings banks have defeated the growth of building and loan associations. In the South and West, the same influences which defeat savings banks have defeated the building and loan associations.

The ten states whose associations have the greatest aggregate membership and deposits are as follows:

**BUILDING AND LOAN ASSOCIATIONS IN TEN STATES HAVING
GREATEST AGGREGATE MEMBERSHIP AND DEPOSITS**

State	Number of Associations	Total Membership (In millions)	Total Assets (In millions)
Ohio.....	723	842	\$ 359
Pennsylvania.....	2,124	725	355
New Jersey.....	792	348	169
Massachusetts.....	186	247	140
Illinois.....	681	240	119
New York.....	249	200	89
Indiana.....	346	198	80
Nebraska.....	73	104	57
Maryland.....	590	87	41
Michigan.....	70	82	37
All others.....	1,650	934	448
Total.....	7,484	4,011	\$1,898

The total management expenses for the year 1918 were less than .8 per cent of the total receipts. There were paid in weekly dues \$434,000,000, and in interest \$108,000,000, in premiums \$5,000,000, and in fines \$1,000,000. The mortgage loans amounted to \$480,000,000, and pass-book loans to \$43,000,000.

Savings in the United States

In the United States are provided many instrumentalities for saving, which, while they are not fundamentally savings bank institutions, are nevertheless powerful means to thrift. Of these, war savings certificates and thrift stamps, life insurance and fraternal organizations are examples.

As compared with certain European countries, however, the sum total of savings in the United States—in commercial banks, savings banks, and trust companies, postal savings banks, and savings effected by the means just mentioned—is relatively small in the light of population and wealth. This showing is too com-

monly taken to prove that we are not a thrifty people. The fact is that no small part of our saving is done by corporations. The net profits of corporations, after payment of taxes, are divided between dividends and corporate surplus; they are invested in materials, supplies, plant, securities, and accounts receivable, or are held as cash on hand or on deposit with banks. A large part of the investment in banks, industrials, railroads, public utilities, and mines has been made out of the profits retained in the business and not declared as dividends. In France the corporate profits tend rather to flow to the investment market where they are more in evidence as the product of thrifty people. In the United States the thrift is exercised by corporate directors, and the people are relieved of the inconvenience of abstinence from consumption, for they are largely unconscious that saving is being accomplished.

The Loan Shark

Where banks fail to serve a community, an opening is afforded for private persons to perform some of their functions. Certain pathological conditions in society may also occasion and maintain the activity of such persons, even against the efforts of banks to serve the particular need and against the efforts of reformers to eradicate what is usually an evil. One such person is the "loan shark," who specializes in personal loans.

"Loan shark" is the popular designation of a person who makes it a business to exploit, by charging extortionate interest, the real or fancied financial needs of individuals who have no other resource which they are willing or able to utilize. These professional money-lenders are of several types: (1) The chattel loan-broker is one who takes as security mortgages on furniture, household effects, or other personalty of the borrower; these mortgages are skilfully drawn to protect the creditor both as against the usury law and against default of the borrower. (2) The salary loan-broker is one who takes as security an assignment

of the wages of the borrower; as a variation, he sometimes purchases the salary so as to evade the usury law. (3) The pawnbroker is one who purchases personal property from the needy at a low price and enters an agreement to resell it to the borrower within a specified time at a specified higher price. The resale price rises fast in case prices are specified for several dates, the difference between the purchase price and the resale price always constituting a high rate of interest. Legally speaking, however, the transaction is a contract of sale and not of loan and the usury laws are thus evaded, the borrower being free to buy back the article if he chooses. There are other types and variations of these money-lending methods. Some brokers employ all three methods mentioned above and others in addition.

The business is highly questionable in character and is done under cover of secrecy and confidence. The want of publicity makes it particularly difficult to obtain accurate statistics of the number of loan-brokers and the volume of their business. The director of the Division of Remedial Loans of the Russell Sage Foundation in 1911 stated, as his conclusions from extensive investigations, that in cities of 30,000 people or more one usurer would be found to every 5,000 or 10,000 people, and that about 5 per cent of the population borrowed. In 1911 an investigation in Chicago found 239 firms operating, with an average business estimated at \$85,000 each a year, or nearly \$11,000,000 for the one city.

The interest rates charged are extortionate. In Pittsburgh, in 1909, they were found to range "from 40 per cent in a very few cases to about 120 per cent in most, and in the case of the so-called 'renewal' loans, to as high as several hundred per cent." The business is therefore highly lucrative. The brokers have perfected very reprehensible ways of collecting illegal charges and skilful processes for evading the usury law. The high rates are more than enough to cover the alleged high risks, for the lender amply protects himself in various ways: The amount of the loan

is usually small and within the earning possibilities of the borrower; loans on assignment of wages are more freely made to employees of firms which forbid their employees to borrow from money-brokers in this way, because the brokers are then put in a strategic position to extort payment under threat of exposure; sometimes bills of sale of salary are used to evade the usury law; often several indorsers are required and their salaries jointly assigned; and the great desire of the borrowers to keep the loan confidential gives the broker a lever for intimidation at the time for collection.

In order to conceal their true character, the loan sharks operate under various designations. They are ostensibly real estate dealers, coal dealers, lawyers, bankers, tailors, etc. Only 18 of the 239 in Chicago were found to be incorporated, and of the charters granted 8 had been canceled for failure to make reports to the state. None of those incorporated had charter powers to engage in lending money. Among the loan sharks it is not deemed wise to incorporate, for a change of name is necessary at frequent intervals to bury their unsavory past.

The money-brokers get business by advertising in the city papers, by circularizing the public with hand-passed bills, by personal solicitation, by having indebted customers act as agents on commission basis, and by exchange of names of old, disgruntled customers. In collecting they prey upon the borrower's ignorance of his legal rights, of his means of redress, and of the nature of the obligations he has signed. To this end the brokers use an elaborate set of legal or apparently legal papers that confuse the borrower and give the advantage to the creditor; they rely more upon bluff and intimidation and threats than upon legal security. In Chicago the money-brokers, for the purpose of getting the credit record and responsibility of applicants, maintain a very secret central credit clearing house which is highly organized and which is an efficient and valuable protection against weak borrowers.

Remedial Loan Systems

Against the evils of the loan shark business three correctives have been used:

1. Campaigns of publicity through the newspapers.
2. Legislation on the one hand so penalizing usurious lending and sharp practices as to make them an extra hazardous occupation, and on the other hand legislation permitting decent substitutes for the loan sharks.
3. The organized defense of loan-shark victims through legal-aid societies.

The substitutes thus far set up are of the several types enumerated below:

1. Substitutes of a purely philanthropic nature, such as the funds created by religious or fraternal orders for loaning to needy members free of interest, or funds established by employers for loaning to their employees.
2. Semiphilanthropic societies, which, while established primarily for the sake of the borrowers, are run upon business principles, the best examples of these being the provident loan associations that are members of the National Federation of Remedial Loan Societies. These are neither wholly charitable in purpose or operation, nor are they wholly commercial. In 1918 there were 34 societies in this federation, in all parts of the country. The federation was founded in 1909, and co-operates with the Russell Sage Foundation. The Collateral Loan Company of Boston is the oldest member of the federation, its establishment dating from 1859.
3. Self-help societies, which include the co-operative credit unions or people's banks. These are very common in Europe and were introduced into the United States in 1909, when Massachusetts enacted her Credit Union

Law. Other states have followed her lead and societies of this kind are spreading widely.

4. Purely business societies, which, while doing an unquestioned social service, aim particularly at profits and keep within the usury law. The best example of this type is the Morris-plan bank.

Morris-Plan Banks

In 1910 Arthur J. Morris, a lawyer of Norfolk, Va., after a study of the co-operative industrial banks of Europe with a view to adapting their principles to American conditions, established an industrial loan bank at Norfolk. It was successful, and since then similar banks have been established at an increasing rate all over the United States, until on the tenth anniversary of the Norfolk bank there were 103 such banks. These institutions had, in the ten years of their existence, made 950,000 loans aggregating \$155,000,000, and in the last year alone 275,000 loans aggregating \$55,000,000. The banks are commonly called after the domiciling city; for example, the New Haven Morris Plan Company, or the Morris Plan Company of Toledo. The New York bank has a branch in Brooklyn, and the Providence bank has branches in Pawtucket and Woonsocket.

These banks are owned and controlled by local capitalists. The capitalization ranges from \$10,000 in Charleston, S.C., to \$1,000,000 in New York and Chicago. The aggregate capitalization of the 103 banks is \$12,500,000. The banks have received the whole-hearted indorsement of the leaders in the communities' activities, and the stockholders include bankers and business men of even national repute. Dividends range from 4 to 8 per cent.

In 1914 Mr. Morris organized, with a capital of \$3,700,000, the Industrial Finance Corporation of New York, which acts as a centralizing feature for the local independent banks. It owns from 10 to 25 per cent of the capital stock of the local banks,

and in a few cases all the stock; in general it does not have a controlling interest. It acts as propagandist of the Morris plan and has active organizers in the field. It provides service departments for the local banks; attends to legislation, pushing such laws and amendments as are necessary or beneficial to industrial loan companies; rediscounts trade acceptances and notes for the local banks, thus acting as a source of funds; and borrows by sale of national trust certificates sold through the local banks. Among the local independent banks opinion varies as to the advantages derived from the corporation. The locals are also associated in the National Association of Morris Plan Bankers, which makes possible associated action independent of the corporation.

The Morris-plan banks are not pawn shops and do not accept pawns, chattel mortgages, or salary assignments as security for loans. They loan to any person of good character and habits who can get two responsible people to indorse his note. The borrower and indorsers apply for a loan by filling out a certificate that covers the character, financial record, and responsibility of each party, and facts as to his employment and wages. If the application satisfies the loan committee, the makers sign a joint and several note and pledge as security an "investment instalment certificate." The note runs one year. The cashier pays the borrower the face of the note less interest at 6 per cent for one year and an investigation fee of \$1 for every \$50 borrowed, this fee, however, never exceeding \$5. The borrower agrees to buy, for every \$50 borrowed, an investment instalment certificate and to pay for it at the rate of \$1 a week. After the twenty-fifth week the payments begin to draw interest at 4 per cent, and at the end of fifty weeks the fully paid certificate can be used to cancel the loan or be exchanged for a "Morris-plan full-paid investment certificate," which bears 5 per cent interest and can be cashed on 30 days' notice to the company. These certificates are bought by bankers and others as an investment for their surplus cash.

A loan under the Morris plan is made only for useful purposes, and is regarded as legitimate when it will increase the borrower's efficiency, put his affairs in better shape, provide for his family, meet the sudden expenses that come from illness or misfortune, or develop his earning power. The range of uses is therefore very wide. The borrowers come from all walks of life and are of both sexes.

Advantages of Morris Loan Plan

The advantages of the Morris plan are many:

1. It promotes thrift. The loan and partial payment plan trains the borrower to weekly savings, and after the loan is repaid he will likely continue to save and take out investment certificates on the weekly payment plan.

2. The loans are based on character and habits; they develop self-respect, whereas loans obtained through a pawn shop or by an assignment of wages have a blighting effect upon the borrower. The Morris plan is not a philanthropic scheme, but puts loaning on a businesslike basis to worthy people at moderate rates of interest. These banks are an effective means of combating the loan shark.

3. The loans are made easy to repay by the weekly or fortnightly payments, adjusted to pay-days.

4. The system of weekly payments is adapted to many useful ends. The Industrial Finance Corporation has developed a system of meeting life insurance premiums by the use of investment instalment certificates. In addition, the Morris Plan Insurance Society has been organized as an adjunct, capitalized at \$200,000. It has written over 17,000 policies, for about \$2,375,000 worth of insurance. The insurance helps to protect the indorsers of the notes, but it is not required by the loaning bank. Merchants are invited to discount their trade acceptances at the Morris plan bank, letting the customer pay the acceptance by buying instalment certificates against maturity. Merchants are also invited

to have their accounts receivable collected in this way. Instalment dealers particularly find this plan very helpful.

5. Sums ranging from \$25 to \$500 or more may be borrowed, without security, by a class who cannot borrow at the commercial banks. The average loan is \$125. This ability to borrow has proved a boon to the honest but poor industrial classes which have no banking connections, and on their loans to date the banks have lost less than 0.1 per cent.

Cattle Loan Companies

Some years ago cattle-raisers depended upon the small state banks, the national banks, and certain livestock commission houses at the central markets to finance their industry. Because of the inadequacy and want of dependability in these sources of loans, the cattle industry required some specialized institution for its finance. In recent years the need has been supplied by the cattle loan companies. Cattle loans are made on livestock, particularly cattle, to provide funds for developing and finishing the animals for market. The packing houses have had a keen interest in this business, not only as a source of profits from loans but also because the loan companies sustained and developed the industry as a whole and thus kept a steady flow of cattle to the packing plants.

Loan companies are located in all the large livestock markets, and some have been organized in producing centers. Some of these companies are independent, while others are affiliated with state or national banks located at the stockyards, the relationship being usually that of interlocked directorates or the possession of officers in common. The parent banks' reason for such affiliation is that they are limited in the amount of loans they can make to one client, usually 10 per cent of their capital and surplus, and from the point of view of profits the larger cattle loans are the most desirable. Other advantages of organizing affiliated loan companies are: (1) the loan company does not have to keep a

legal reserve; (2) the loan company is not subject to the double liability on stockholders; (3) the bank has a convenient source of commercial paper.

The loan company also enjoys certain advantages from this affiliation: (1) it has an added prestige; (2) it can use the bank's credit department and machinery; (3) it can turn over the small loans to the bank; (4) in dull times it can sell the surplus paper to the bank's correspondents.

Among the officers of the loan company is sometimes found a practical cattleman, who not only passes on the loans but also inspects the collateral offered as security. In some companies inspectors are employed whose duties are to travel over the territory where loans are made and make inspections of the ranches, cattle, and facilities for handling them, at least once during the life of the loan. Other companies use resident inspectors, who are called upon from time to time to make inspections and reports.

Nature and Terms of Cattle Loans

An applicant for a loan prepares a financial statement, describing the stock he has to offer as collateral and the facilities for taking care of it, the amount of real estate he owns or has leased, and his outstanding debts. The loan company verifies the borrower's statement by confidential inquiries through banks and other parties; it searches the county records to verify the recorded debts of the borrower; it has an inspector make a personal inspection of the facilities for caring for the stock, the amount of feed on hand, the general reputation of the applicant as a cattleman, and the number of his cattle, at the same time determining whether they correspond with the description given in the application. The loan is generally made or rejected on the inspector's report. The business reputation and honesty of the applicant and the condition of the livestock and money markets, are other important considerations. If the application is approved, a note is drawn, and, as collateral, a chattel mortgage on the stock and

its increase, on the feed on hand, and sometimes on the facilities for handling the stock, such as horses and machinery.

The amount loaned varies from 50 to 80 per cent of the full value of the stock; a margin of 20 to 25 per cent is considered amply sufficient, for the natural increase in weight and number of the animals reduces the hazard of cattle loans. The size of the loan varies from a few hundred to a million dollars. Small loans are more advantageously made through local agencies, since local agencies are familiar with the applicant and his financial standing and do not have the expense of inspection. Moreover, small loans are generally too costly for cattle-loan companies.

The loans are for short terms, generally running for six months. This period of time is adopted because of the rediscount feature of the cattle-loan business, and because that length of time will ordinarily be long enough for the "feeding out" of a bunch of cattle. In the case of loans on stockers and breeders, it is understood that the loans will be renewed if desired. The loans are commonly classified as feeder loans, stocker loans (on cows, on young stock, and "summer loans"), and dairy loans. It is assumed, of course, that the proceeds of the loan will be devoted to the improvement of the herd.

The interest rates depend upon the rediscount rate and the degree of competition among borrowers and among lenders. Only marked fluctuations of the rediscount rate affect the local rates charged. The rates will also be graduated according to the desirability of the applicant. The cost of inspection has an important bearing upon the loan rate, for it must be assessed back upon the borrower, and therefore borrowers living in remote and isolated places have to pay higher interest rates.

Rediscounting Cattle Paper

The loan company procures its funds largely from the money centers by the process of rediscounting the cattle paper, though some of the loans are rediscounted locally. The company for-

wards to the bank the note, together with the mortgage and sometimes copies of the inspector's report and the financial statement of the maker. It also indorses the note and thus guarantees its payment, the value of the guaranty depending on the character of the company and on its capital, and the buyer of the paper looks rather to the loan company than to the cattleman borrower. The paper is largely sold to eastern banks. The loan companies establish affiliations with strong banks that are in the market for commercial paper, and take all precautions to develop a good reputation, so that their offerings will be readily taken. By this process of rediscounting the loan company subjects itself to a contingent liability as guarantor to a volume of paper much larger than its capital.

Security and Liquidity of Cattle Paper

The security of the paper is enhanced by the fact that the company's loans are scattered among many cattlemen, the simultaneous failure of whom is quite unlikely. Hence the buyer of paper from such a loan company is more secure than if he bought a mortgage note of a single cattleman; in addition he is relieved of the bother and expense of inspecting his security and of seeing that it does not deteriorate. The spread between the interest rate and the rediscount rate is from $1\frac{1}{2}$ to 3 per cent, and generally between 2 and $2\frac{1}{2}$ per cent. The cost of making the loan is from 1 to $1\frac{1}{2}$ per cent, and, other things being equal, the cost decreases with the size of the loan. The difference between the spread and the cost represents the profits of the loan company.

The security behind cattle loans therefore rests upon a number of factors, including careful investigations of the borrower and his collateral, recording of the brands and descriptions of the cattle, provisions to see that the proceeds of sales of cattle bearing these brands are turned over to the holder of the note and mortgage, the integrity and business sagacity of the loan company, and its assets.

Cattle paper is especially liquid. While renewals are necessary on stocker and breeder loans, requests for renewals are unusual in the case of feeder cattle, which must be marketed when ready as any lengthy delays will cause loss. Therefore loans on feeders automatically liquidate themselves. In the commercial paper market cattle paper has a very good reputation.

Cattle-loan companies thus furnish the cattlemen with large loans; as the cattle industry on the range is conducted on a large scale, larger loans are necessary there than can be provided by local banks. The loans, too, are at rates lower than local capitalists would generally accept. The companies tend to promote the cattle industry, steady the price of beef, increase the food supply, and perform other economic functions.¹

The Federal Farm Loan System

The federal farm loan system was instituted to organize the market for real estate mortgages and facilitate long-term loans to farmers. As will be shown later, the national banks fail to provide rural credits to the degree that they provide commercial, mercantile, and industrial credits; the state banks, although they have done more to this end than the national banks, have likewise proved inadequate. In fact, the fusion of commercial banking and long-term rural credit operations is held in the United States to be theoretically and empirically unsound. The unfortunate heavy failures of many mortgage bond houses in the nineties also disinclined capital to enter the mortgage field. After an educational and legislative struggle of a decade or more, a rural credit system was inaugurated by Congress in 1916.

The system consists of a Federal Farm Loan Board, with jurisdiction over two schemes of providing rural credits:

1. That provided by twelve federal land banks, owned by some 4,000 co-operative national farm loan associations.

¹ See Bulletin of National Association of Credit Men, Oct. 1917, p. 955; *Journal of Political Economy*, Vol. 26, p. 807; Year Book, Department of Agriculture, 1918.

2. That provided by some 30 federal joint-stock land banks, which are joint-stock farm mortgage bond companies with federal charters.

Federal Land Banks

The federal land banks are central mortgage bond institutions. The country is divided into twelve districts, with boundaries conforming to state lines because the federal land banks have to conform to the state laws affecting real property, entail, etc. In each district is a federal land bank, in a central city selected largely from considerations of convenience, and the bank is named after the city. The minimum capital of each federal land bank is fixed at \$750,000, to be subscribed by the national farm loan associations and by the public, the government to subscribe any necessary residue. The subscription by the government and the public, however, is to be absorbed later by the loan associations as loans are placed by them.

The twelve banks began operations in the spring of 1917 with an aggregate capital of \$9,000,000, of which \$8,892,130 was subscribed by the government and \$107,870 by individuals. During the first year and part of the second the banks were run at a loss; but by January 31, 1919, these deficits had been made good, and by December 31, 1920, \$2,059,450 of the government's subscription to capital stock had been retired and the aggregate capital stock of the banks had risen to \$24,591,515. No dividends were paid on the government's holdings. Up to December 31, 1920, the twelve banks had carried \$2,861,326 to reserve and undivided profits and all had declared dividends on stock owned by loan associations and the public. No limitations are put on the dividends that may be declared. A reserve equal to 25 per cent of the stock held by the loan associations is to be held, either in cash or in liquid securities; and one-fourth of its net earnings must be carried to this reserve until it reaches 20 per cent, and thereafter only one-twentieth. Up to September 30, 1919, of

the payments due from borrowers to the banks 1.4 per cent was overdue, but one-half of this amount was overdue less than 30 days.

The law provides that the federal land banks may establish branches in their districts in order to bring the service of the system nearer to the borrower. An amendment of February 27, 1921, extended the system to Porto Rico by authorizing the Federal Farm Loan Board to designate some federal land bank which is permitted to establish a branch at such place on the island as the board may direct.

Federal Farm Loan Bonds

Besides the subscriptions to their capital stock and the surplus and reserves accumulated out of earnings, the federal land banks are permitted to issue bonds, known as "federal farm loan" bonds, which are made obligations of the United States government and are secured by first mortgages on improved farm lands in the United States. The security behind these bonds seems unquestionably strong since (1) they are direct obligations of the United States; (2) they are issued under a national system, subject to national supervision; and (3) they are secured by the assets of the issuing bank, and the twelve banks are jointly and severally liable for principal and interest of each and all the bonds issued by any and all the banks. These assets, outside of the cash reserve, consist largely of first mortgage notes, the mortgages being for sums which range from one-half to one-fifth the value of the mortgaged realty, these fractions becoming smaller as repayments on the loan are made. The mortgages are placed only on farms that are occupied and tilled by the owner (borrower), and loans are not made to absentee landlords and speculators. Moreover, the mortgages are indorsed by the local national farm loan association, the members of which are jointly and severally liable to an amount double that of their holdings of capital stock. The period of the mortgages ranges from 5 to 36 years, and provision

is made for amortization of the principal by annual level payments of at least 1 per cent in excess of interest charges.

The borrowing farmers, by adopting the principle of collective indorsement or guaranty, improve the security behind their mortgages. As an alternative to the local national farm loan association, the act provides that the federal land bank may engage loan agents in its districts, but in this case the agent must provide the added security by the guaranty or indorsement of a responsible and acceptable third party.

Under the old system an investor bought the original mortgage and note, and was thereby subject to certain disadvantages, since he must either have personal knowledge of all the essential circumstances affecting the security in question or he must rely upon a third party for such information and protection. The federal land bank now constitutes the market for such mortgages and notes, and regulates and supervises their issue and watches their security. It assembles farm mortgages carefully selected according to reliable standards, and on the basis of such mortgages as collateral issues bonds in convenient denominations, running for suitable periods of time, and with convenient and reliable means for collecting the payments of principal and interest and with a ready market if at any time the holder wishes to sell the bonds.

The bonds have other good investment qualities besides their excellent security. They run for 20 years, bear $4\frac{1}{2}$ or 5 per cent interest, are tax-exempt, are acceptable by the government as security for government and postal savings deposits, are a legal investment in most states for trust funds, and are safeguarded by the fact that the total volume of loans may not exceed 20 times the capital and surplus of the issuing bank. During 1917-1918 war financing cut off the market for these bonds, and Congress authorized the Secretary of the Treasury to buy \$200,000,000 of them to hold until the market should become favorable. The sale of federal farm loan bonds has been somewhat retarded by

doubt as to the constitutionality of the Federal Farm Loan Act; this handicap was removed, however, by a decision of the United States Supreme Court, February 28, 1921, sustaining its constitutionality.

National Farm Loan Associations

The national farm loan associations are co-operative credit associations, modeled upon the credit unions prevalent in Europe. They consist of ten or more natural persons who are owners, or who are about to become owners, of land that qualifies as security for mortgages under the law. The shares of these associations are \$5, and the members have to make a one-share subscription for each \$100 borrowed. The members have one vote per share, but no member is allowed more than twenty votes. The association has control of its membership and elects its own officers. The associations select the loans, appraise the security, transmit blanks and forms to and from the federal land bank, handle the funds, distribute the dividends on the basis of the amount of loans to members, guarantee the mortgage by their joint indorsement and stock ownership, and attend to the upkeep of the loan and security. Five per cent of the loan is subscribed to the stock of the association, and the association then subscribes 5 per cent of its borrowings to the stock of the federal land bank. The maximum loan to any one person is \$10,000 and the minimum \$100. The loans may not exceed 50 per cent of the value of the improved real estate and 20 per cent of the value of the improvements. The loans are determined upon by a local loans committee, but the appraisals of the security are made subject to revision by an appraiser appointed and controlled by the Federal Farm Loan Board. Statistics indicate that about 8 per cent of the proceeds of the loans is used to buy land, 10 per cent for buildings and improvements, 60 per cent to pay off existing mortgages, 10 per cent for payment of other debts, 5 per cent for purchase of the federal land bank stock, 4 per cent for purchase of livestock,

and 3 per cent for implements and equipment. It is provided that the loan rate to the local borrower cannot exceed the rate on the last issue of bonds by more than 1 per cent, that is, the total expenses of the system are to be covered and dividends declared out of this maximum margin. The secretary-treasurer is the most important person connected with a local association, and for the most part he renders his services for a merely nominal compensation.

These associations, which are being organized throughout the United States—the fewest in the region northeast of Indiana and in the mountain states of the West—amounted in 1920 to approximately 4,000. The loans made by them are distributed among the districts as follows:

TABLE SHOWING DISTRIBUTION OF LOANS BY NATIONAL FARM
LOAN ASSOCIATIONS

District	Federal Land Bank of	Aggregate of Loans Made from Date of Or- ganization in March, 1917, to December 31, 1920 (In millions)
No. 1	Springfield, Mass.....	\$ 13.6
2	Baltimore, Md.....	14.7
3	Columbia, S. C.....	20.4
4	Louisville, Ky.....	27.8
5	New Orleans, La.....	25.8
6	St. Louis, Mo.....	31.2
7	St. Paul, Minn.....	49.6
8	Omaha, Neb.....	48.9
9	Wichita, Kan.....	31.6
10	Houston, Tex.....	40.8
11	Berkeley, Cal.....	18.6
12	Spokane, Wash.....	46.2
	Total	<u>\$369.2</u>

Joint-Stock Land Banks

The joint-stock land banks are private mortgage bond companies, composed of ten or more natural persons, organized for profit, chartered under federal law by the Federal Farm

Loan Board, and operated under its general supervision. They are capitalized at \$250,000 or more, and receive no help from the government by way of capital subscriptions. The federal charter and supervision are presumed to give a higher prestige to these private land banks than they enjoyed under state charter and supervision, and therefore to add to their credit title. They cater to farmers who wish loans in excess of \$10,000, the maximum which the federal land banks are allowed to make, and to others than farmers who themselves till the soil. These banks make it possible for a farmer who does not wish to join a national farm loan association, or is not qualified to join, or has no access to such association, to secure loans on real estate. The same provisions about loans, mortgages, security, and amortization govern the operations of the joint-stock land banks as govern those of the federal land banks and farm loan associations, except that their total loans may not exceed 15 times their capital and surplus and that the operations of any one bank are restricted to two adjacent states. The valuations are determined by the appraisers of the Federal Farm Loan Board. Upon the basis of mortgage notes and first mortgages pledged as collateral the joint-stock banks may issue bonds, which have nearly the same qualities as have the bonds issued by the federal land banks. Both classes of bonds have been marketed largely through syndicates of bankers in New York and Boston.

Up to January, 1921, of these joint-stock land banks 30 had been organized, most of them during 1919 and therefore not yet in full and active operation. Nevertheless their total loans amounted to \$77,958,642, and this class of loans gives promise of very fast growth later on. The restriction allowing banks to operate in only two adjacent states each, together with the fact that those which have been organized are concentrated about Iowa, restricts their loan area to relatively few states and permits the federal land banks to enjoy a monopoly in a majority of the states.

Federal Farm Loan Board

The whole system is supervised and controlled by the Federal Farm Loan Board, composed of the Secretary of the Treasury and four other members appointed by the President and confirmed by the Senate. It is a non-partizan board and representative of the whole country. The members are appointed for 8 years, the chief member being known as the "Farm Loan Commissioner." The board appoints in each district a farm loan registrar, land bank appraisers, and land bank examiners, thereby concentrating power, responsibility, and control in the board. The law provides that the expenses of the board and of these appointees shall be paid by the United States, but the system is now so well established and in such financial condition that, in the judgment of the board, concurred in by the officers of the banks, the payment of its expenses by the government is no longer necessary or desirable. The board has accordingly recommended that its expenses for 1921 be assessed against the federal land banks and joint-stock land banks in proportion to their gross assets.

CHAPTER XXV

BANK ORGANIZATION AND CONVERSION

Introductory

The purpose of this and the following chapter is to set forth in a general way the necessary procedure to be followed when a new bank is organized, a state bank converted to a national bank, two banks consolidated, a national bank liquidated, or when related events occur. These matters are defined by statutes and by regulations of the Comptroller of the Currency and of the state superintendents of banks. Statutes and regulations applying to national banks differ from those applying to state institutions; and even among the state institutions, the law and regulations differ according to the various states and also differ with the kind of institution, whether commercial bank, savings bank, trust company, private bank, etc. In general, the procedure in case of national banks is taken as the standard for the state law and regulations.¹

Organization of a New National Bank

A national bank may be started in one of three ways, according to existing conditions and desires: (1) by creating a new bank, (2) by reorganizing a state or private bank into a national bank, or (3) by converting an incorporated state bank into a national bank.

The initial step in organizing a national bank is to write the Comptroller of the Currency asking him to reserve the desired title and stating the bank's location and proposed capital. The Comptroller will reserve the title for 15 days, within which time

¹ For a more detailed statement of this subject, see "Instructions of the Comptroller of the Currency Relative to the Organization and Powers of National Banks," Washington, 1919.

a formal application to organize is expected to be filed. The title of a national bank must include the word "National" or be followed by "National Banking Association" (usually abbreviated, "N.B.A."); it should include the name of the place where the bank is situated, but not of the state; it may not include the word "First" if a national bank already exists in the place, nor may it be identical with the name of a national bank heretofore in existence, nor materially similar to the name of any bank in the place, whether national, state, or other. The reason for these rules is obvious.

Requirements for Formal Application

The formal application for reservation of title and authority to organize a national bank—made on a blank furnished by the Comptroller—must be signed by at least five persons who are prospective shareholders of the bank, and preferably also prospective officers or directors. It should be indorsed by three prominent public officials, preferably the local mayor and postmaster and a judge of court, persons who are sufficiently acquainted with the incorporators to certify that they are reputable citizens and that their business and financial standing is favorable for the success of the new bank. The relation, if any, in which the applicants stand toward other banks must be stated.

A list of the officers and directors should be furnished to the Comptroller as soon as possible. If any of the applicants has ever been connected with the organization, or attempted organization, of any other national or state bank, the facts of the case must be stated. The organization expenses allowable are limited to those strictly incident to the actual organization of the bank, and do not include commissions for the sale of stock or promotion fees. The capital and surplus must be paid in money alone. These rules tend to eliminate the professional bank promoter, their object being to show there is a genuine local demand for the bank, thereby lessening the chances of failure. Bank failures

seriously affect public confidence and favor. Hence it is essential that such failures be kept as few as possible. For this reason the Comptroller generally refuses the application to establish a bank at a place where, because of apparent lack of business, there is little likelihood of the bank's success, where existing banking facilities, state or national, already are unquestionably ample, where the character or financial ability of the applicants is questionable, or where the demand for the bank springs from outside promoters and not from the local business interest.

The amount of capital required for a new bank depends upon the size of the town in which the institution is to be located: capital to the amount of \$25,000 being required where the population does not exceed 3,000; \$50,000 where the population exceeds 3,000 but not 6,000; \$100,000 where the population exceeds 6,000 but not 50,000; and \$200,000 for all places with a population over 50,000. National banks organized in suburban districts included within the political boundaries of the city must have the capitalization required of a bank organized in the city proper. The proposed capitalization of the bank must be stated in the formal application blank.

Examination of Application

The application blank should be accompanied by a draft for \$100, payable to the order of the Comptroller, to cover the expense of investigation. Owing to the number of banks organized by professional promoters, and by rival interests, for spite or other reasons, it is the policy of the Comptroller to refer applications to the chief national bank examiner, with instructions to detail an examiner to make an investigation. In making this examination the examiner is instructed to give full consideration to all factors entering into the matter. Specifically he is to consider the adequacy of the existing banking facilities and the need of further banking capital, the methods and banking practices of the existing bank or banks, the interest rates which they charge

to customers, the character of the service which as quasi-public institutions they are rendering to their community, the outlook for the growth and development of the city, the general character and experience of the organizers and of the proposed officers of the new bank, and the reasonable prospects for its success if it is efficiently managed. If protest should be made against the organization of the bank, the examiner is most careful to listen to argument on both sides. In addition to the report from the examiner, the Comptroller obtains a report from the federal reserve bank of the district, another from the state banking department, and others from such additional sources as he may deem advisable.

If the application is granted, the Comptroller forwards to the incorporators the following organization blanks: articles of association, organization certificate, oaths of directors, signatures of officers, by-laws, certificate as to payment of capital stock, and order for circulation.

Articles of Association and Organization Certificate

The incorporators first draw up and execute in duplicate the articles of association and the organization certificate, and then forward one copy of each of these to the Comptroller. The articles of association state the terms under which the stockholders agree to do business and contain the title of the bank, its location, the number of directors and the manner of electing them, the date and number of stockholders' meetings, the capitalization, the powers and duties of the board of directors, the term of the charter, and the method of amending it. The articles are signed by at least three shareholders, preferably the five incorporators, and may be varied to meet the views of the incorporators so long as the changes are consistent with the national banking laws.

The provisions of the organization certificate are prescribed by statute. They include a statement of the title, location, and

capital of the bank, together with the total number of its shares, the names and places of residence of the shareholders, the number of shares held by each of them, and the chief purpose of the certificate. It is signed by the same persons as sign the articles of association and is acknowledged by all signing parties before a notary public or a judge of a court of record and authenticated with a seal. The association becomes a body corporate from the date on which the organization certificate is executed.

Election of Directors and Officers

The next step in the organization procedure is the stockholders' meeting for election of the directors. In case the directors are specifically named in the articles of association this first election meeting may be dispensed with. Thereafter directors are elected in January of each year, for one year. After election they are required to take, either singly or jointly, the oath prescribed by statute before an officer having an official seal, and these oaths are sent to the Comptroller.

The first business of the board of directors, upon organization, is to adopt by-laws and a corporate seal. The by-laws set forth the manner in which the business of the bank is to be conducted and state the powers and duties of its officers. Although they are adopted and amended by the board of directors, they must not be inconsistent with the articles of association. The board then elects a president, a vice-president, a cashier, and such other officers as may be necessary to conduct the bank's business. A copy of the by-laws, together with a list of the officers and their respective signatures, is forwarded to the Comptroller. The official signatures are respectively accompanied by a statement of the date of election or appointment of each officer, and the name of his predecessor. It is required that the by-laws provide that a meeting of directors be held at least once a month and that any action taken by the bank's discount committee be approved or disapproved by the board and recorded in the minute book.

Requirements as to Capital Stock Subscriptions

After the election of officers, the board should call in the subscriptions to the capital stock. The law requires that 50 per cent of the capital stock of a national bank shall be paid in cash and permits the payment of the other 50 per cent in 5 equal monthly instalments. The subscription contract entered into by the prospective shareholders, however, may provide that at the call of the directors payment shall be made of the entire amount due on each share.

The Comptroller requires that every share be issued to bona fide subscribers and be placed when the organization certificate is executed. If the subscriptions are to be paid in instalments, temporary stock certificates are used and the amount of each payment entered thereon; these are exchangeable for permanent certificates when all instalments are paid.

The Comptroller urges the advisability of selling the shares at a premium of 10 per cent or more for the purpose of creating a surplus out of which the organization expenses and the salaries of the officers for the first year or two may be paid. The amount of money expended in a bank building should also be restricted to prudent and economical limits. If the shares are not sold at a premium no dividends should be paid until a substantial surplus is accumulated out of earnings. If the shares are sold at a premium of 20 per cent or more, dividends distributing the whole net earnings may be declared from the first; otherwise a portion of the net earnings must be carried to surplus.

The payments of subscriptions must be certified to the Comptroller by the president or cashier and a majority of the directors. Should a subscriber to stock or his assignee fail to pay any instalment on the stock, the directors of the bank must sell the stock at public auction, after giving three weeks' notice of such sale in a newspaper published in the town or city where the bank is located.

The bank is required to make a subscription to the stock of

the federal reserve bank of its district equal to 6 per cent of its own capital and surplus. The basis of payment for the federal reserve bank stock is par value plus $\frac{1}{2}$ per cent a month from the time of the last dividend payment.

Upon receipt by the Comptroller of the certificate of these capital payments, the Comptroller issues to the bank its "charter," a certificate which gives the bank authority to do business for a period of 20 years. This certificate authorizing the bank to commence business must be published in the city in which the bank is located, or, if no newspaper is published in the city, then in a county paper or near-by city paper, and this publication must be certified to the Comptroller.

Requirements as to Circulation

Prior to the passage of the Federal Reserve Act, an applicant bank before being permitted to do business was required to deposit with the Treasurer of the United States what were known as "charter bonds." The Federal Reserve Act repealed this requirement, so that now it is not necessary for the bank to purchase and deposit bonds unless it desires to take out circulating notes. To take out circulation, the bank must send to the Comptroller United States registered interest-bearing bonds, having the circulation privilege, to the amount provided by the National Bank Act, and these bonds in turn are transferred to, and deposited with, the Treasurer of the United States in trust for the sending bank.

Reorganization of a Bank into a National Bank

Occasionally it is deemed advisable by the directors and other shareholders of a state or private bank to enter the national banking system by reorganization rather than conversion. The controlling motive for so doing is generally the desire to effect such distribution of stock as will promote the best interests of the bank, but sometimes it is owing to the specific desire to provide

for a more satisfactory investment of capital and other loanable funds.

In order to reorganize a state or private bank into a national bank it is necessary to close the old bank's affairs in conformity with the laws of the state in which the bank conducts its business, and then effect a new organization in accordance with the requirements of national bank laws. The procedure as to the execution of corporate papers and the subscriptions and payment of capital is the same as if the new bank were not to succeed an old one. A resolution is passed by the shareholders, or other legal action taken, whereby the interests of the stockholders of the old bank are conserved in the new. It is assumed that the owners of a private bank may as individuals terminate their business and sell or transfer the assets to the succeeding national bank.

The law requires that the capital stock of a national bank be paid in cash; it is therefore necessary for the old bank to liquidate enough of its assets to enable the shareholders to pay their subscriptions in cash. If it is impossible to liquidate in a short time enough assets to pay these subscriptions, the old bank may loan to the stockholders. The directors of the new bank then contract with the liquidating agent of the old bank to assume the liabilities to depositors and other creditors of the old bank if the old bank transfers an equivalent amount of assets of a character which can be held by a national bank. Some of the capital paid in may at once be reinvested in the assets of the state bank. The directors of the new bank certify to the Comptroller that the bank will not acquire any of the old bank's assets the holding of which contravenes the provisions of the national bank laws. If it is proposed to buy the old bank's building and equipment the Comptroller requires a detailed statement as to the cost, rent, and expense for taxes, repairs, and insurance. The purchase of these and other assets is covered by a specific contract, legally made only after the charter is granted. The transition from the old to the new bank may be made without a halt in business.

Conversion of a State Bank into a National Bank

A bank incorporated in a state under a special charter or general statute may be converted into a national bank unless such conversion is forbidden by the laws of the state. A trust company organized under state law may be permitted to convert itself into a national bank provided it complies with all the conditions of the law, and divests itself of all its trust company business except such as the Federal Reserve Board may specifically authorize it to retain as provided by the Federal Reserve Act. In the conversion of a state bank there is not a dissolution of the state corporation, but merely a change of title and governmental supervision; the bank is still liable for all obligations and may enforce all contracts made with it as a state corporation. The conversion must be approved by the Comptroller of the Currency.

For conversion into a national bank the law requires that the shareholders owning not less than 51 per cent of the capital stock grant by vote to the directors authority to execute the articles of association and organization certificate and to convert the bank into a national bank, and these and all other papers in connection with the conversion must be executed by a majority of the directors. The minimum number of directors by which the affairs of a national bank can be directed is five; if the state bank has less than that number of directors an increase should be effected under the state law, prior to the execution of any conversion papers other than the application.

The state bank converting must have capital paid in and unimpaired equal to the amount required of a national bank. If it must increase its amount of capital in order to convert, the increase may be made under the state law and the bank may then convert, or the state bank may go into liquidation and reorganize, the deciding factor as to which course to pursue being the requirements of the laws of the state in which the bank is located. Should the bank increase its capital before conversion, the Comptroller of the Currency requires that this increase be

certified to him by the state bank commissioner or superintendent of banks.

A state bank converting into a national bank is not required to issue new certificates of stock; the old certificates may simply be stamped to show the new corporate title and the date of change, but it is better to issue new certificates. Owing to the fact that the old certificates may be retained, it happens that a few national banks have shares of more or less than \$100. Whenever the capitalization is increased or decreased the \$100 denomination is introduced.

Before a charter is granted to a state bank applying to convert, an examination of its assets is made by the bank examiner in that district and his report is forwarded to the Comptroller. The converting bank must contribute \$100 for the expense of this investigation, which is conducted in the same manner and to the same purpose as in the case of the organization of a new national bank.

Certain classes of assets permissible to state banks are forbidden to national banks, and at conversion into a national bank a state bank must liquidate such assets and cease acquiring them in the future. Moreover, the directors must certify to the Comptroller that the converted bank will purchase no prohibited assets, in accordance with the restrictions governing excessive loans, loans secured by real estate, stocks of other corporations, and the like.

Under the Federal Reserve Act a state bank converting into a national bank is permitted to keep any branch or branches which it may have at time of conversion.

Organization of a State Bank—Preliminary Requirements

In 1914 the state of New York revised its banking laws in conformity with the recommendations of the Van Tuyl-Hepburn Banking Commission. As these are therefore comparatively modern, and as the New York laws govern so many large banks in

that state, and as furthermore they are used as a model in the preparation of similar laws in a majority of the states of the Union, it is deemed well to detail the organization of a New York state bank.

The first step for the organizers is to sign and file with the Superintendent of Banks, at Albany, a notice of intention to incorporate as a bank. The notice should be in duplicate, duly acknowledged, and signed by five natural persons, and should give the name, location, and the amount of capital stock of the proposed bank. Upon receipt of the notice the Superintendent of Banks designates in the town or vicinity a newspaper in which the notice must be published for four successive weeks. In addition a copy of the notice is mailed to each state bank and trust company doing business in the town where the bank is to be located.

Within ten days after the final publication of the notice the organization certificate should be forwarded to the Superintendent, together with the by-laws, affidavits, and other evidence showing that the requirements as to publication and notice to other banks and trust companies have been complied with. The organization certificate must contain the names of the five persons who signed the certificate of intention, together with a statement of the name of the bank, its location, the amount of capital stock and number of shares, the name and place of residence of each incorporator with the number of shares subscribed by each, the term of the bank's existence, and the number of directors. The organization certificate is signed by the five persons who signed the certificate of intention to organize. The certificate may also prescribe the manner in which stock may be transferred and the number of directors necessary to constitute a quorum.

When the organization certificate is approved as to detail by the Superintendent of Banks, he proceeds during the next sixty days to learn the character, responsibility, and general fitness of the persons named in the certificate, in order to decide whether they warrant the opinion that the bank will be honestly and efficiently conducted in accordance with the laws of the state.

If he approves the certificate, he notifies the organizers to that effect. One of the duplicate certificates is kept in the office of the Superintendent and the other filed with the clerk of the county in which the bank is located.

Authorization Certificate

The corporate existence of the bank dates from the approval of the organization certificate. But the bank is not permitted to transact business until all its capital stock has been fully paid, in cash, and an affidavit that it has been so paid has been subscribed and sworn to by two principal officers. The affidavit is filed in the county clerk's office and a certified copy of it sent to the Superintendent of Banks. The bank must keep on deposit with the Superintendent, during its existence, stocks or bonds of the state of New York or the United States to the amount of \$1,000; these are registered in the name of the Superintendent and held in trust for the bank, and the interest on them may be collected by the bank so long as it continues solvent. When all requirements of the law as to certificate of intention, certificate of organization, payment of capital, and deposit of securities have been complied with, the Superintendent must within six months after the date on which the organization certificate was filed with him for examination, but in no case after that time, issue, in triplicate, an authorization certificate to the persons named in the organization certificate.

The authorization certificate states that the bank has complied with all lawful requirements of the state, that it is authorized to transact business within the state and that it can be safely entrusted with such business. One certificate is sent to the bank, one filed with the Superintendent, and the third with the county clerk, together with the organization certificate. Upon receipt of the authorization certificate the stockholders should proceed at once to elect a board of directors, who in turn should organize and elect a president, who must be chosen from their own number,

together with a vice-president and such other officers as are required by their by-laws.

Qualifications of Directors

The qualifications for the directors of a New York state bank are the same as for the directors of a national bank, that is, the directors must be citizens of the United States and in the case of three-fourths of the board's membership they must reside in the state at the time of election and during their term of office. Each director must be a stockholder of the bank and own shares in the sum of at least \$1,000 when the capital is \$50,000 or over, and in the sum of \$500 when the capital is less than \$50,000. Each director, whether appointed or elected, must be duly subscribed and sworn by an officer authorized to administer oaths, who must certify to the affidavit and transmit it to the Superintendent of Banks. The tenure of office of a director extends to the next annual meeting of the stockholders, which is usually held in January. In case vacancies should occur in the interval, to a number not exceeding one-third of the board, the remaining members may fill them. Meetings of directors must be held not less often than once a month.

Organization of a Trust Company

A trust company, like a state bank, is organized under state law. In New York it may be formed by seven or more natural persons filing and publishing a notice of intention and filing an organization certificate, in the same manner as in the case of organizing a state bank. The capital requirements for a trust company are as follows:

Population	Capital
Not exceeding 25,000	\$100,000 minimum
25,000 to 100,000	150,000 "
100,000 to 250,000	200,000 "
250,000 and up	500,000 "

When the usual investigation is completed by the Superintendent of Banks and he has indorsed the organization certificate, the corporate existence of the trust company begins, but it cannot commence business until the full payment of the capital stock is certified to the Superintendent and a list of stockholders giving the name, residence, number of shares owned, and post-office address of each of them, is verified by two officers and filed with the Superintendent of Banks. The trust company must deposit with the Superintendent, registered in his official title in trust for the depositors and creditors of the company, interest-bearing stocks or bonds either of the United States, or of the state of New York or any municipality in the state, issued by the authority of the legislature. These deposited stocks or bonds must amount to 10 per cent of the trust company's capital stock and must not be less than \$100,000 if its principal office is located in a city whose population exceeds 500,000, \$50,000 if the population is between 100,000 and 500,000, \$30,000 if between 25,000 and 100,000, and \$20,000 in places less than 25,000.

After all requirements as to certificates of intention, organization, payment of capital and deposit of securities have been fulfilled, the Superintendent of Banks issues an authorization certificate. The persons named in the organization certificate, or such of them as are holders of at least ten shares of stock, constitute the first board of directors, which should number not less than seven nor more than thirty. The directors should then organize and elect a president from their own number, together with a vice-president and other officers required under their by-laws. The directors have a three-year tenure of office and the members of the first board are required to group themselves in three classes so that one-third will be elected and take office annually thereafter. Every director in a trust company must hold in his own right at least ten shares of its capital stock. Not less than two-thirds of the directors must be citizens of the United States.

Conversion of a State Bank into a Trust Company

In New York a state bank desiring to become a trust company must call a meeting of its stockholders, giving them due notice twenty days in advance. If holders of two-thirds of the capital stock agree at the meeting, the bank may be converted. A resolution must be adopted at the meeting directing that not less than thirteen nor more than thirty stockholders of the bank be designated by name to execute an organization certificate to meet the legal requirements. All persons named in the resolution are required to subscribe and acknowledge the organization certificate and attach to it copies of the minutes of the meeting, verified by the president and secretary of the meeting. Duplicates of affidavits of service of notice and of the organization certificate are sent to the Superintendent of Banks, who, upon approval, indorses the certificate permitting the trust company to commence business when the capital stock has been paid up and the required securities deposited. When the corporate existence of a trust company begins, all the property of the state bank immediately becomes the property of the trust company without conveyance or transfer.

Conversion of a Trust Company

The procedure to be followed in converting a trust company in New York is the same as in converting a state bank, except with regard to funds held by a trust company as executor, trustee, or administrator, by decree of court. Before converting, a trust company must divest itself of such funds through court procedure. When this is done, the usual procedure is followed.

Organization of a Mutual Savings Bank

In New York a savings bank may be formed by filing with the Superintendent of Banks a notice of intention to organize, signed by not less than nine nor more than thirty persons. The procedure as to publication of such notice is the same for a sav-

ings bank as for a state bank or trust company. The same also applies to the filing of an organization certificate, which specifically states: (1) the name by which the bank is to be known; (2) its proposed place of business; (3) the name, occupation, and post-office address of each incorporator; (4) the sum which each incorporator will contribute in cash to the guaranty fund; (5) a declaration that each incorporator will accept the liabilities and faithfully discharge the duties of a trustee.

When the Superintendent of Banks approves the organization certificate the corporate existence of the bank begins, and it may proceed with the necessary details to complete its organization; but it cannot transact business until the incorporators deposit, in cash, to the credit of the savings bank an initial guaranty fund amounting to not less than \$5,000. The incorporators are required to enter into an agreement with the Superintendent of Banks as trustee for the depositors of the bank to make further contributions in cash if necessary to conduct the business. The agreement is secured by a surety bond and filed with the Superintendent. In addition to the guaranty fund the incorporators are required to deposit in the savings bank as an expense fund \$5,000 in cash to pay the bank's operating expenses until such time as its earnings are sufficient to pay its way. The guaranty fund and the expense fund are repaid, *pro rata*, to the contributors or trustees whenever the guaranty fund is in excess of 5 per cent of the amount due depositors.

Upon receipt of the organization certificate, the incorporators or board of trustees should organize; adopt by-laws, rules, and regulations; and file with the Superintendent of Banks the name, residence, and post-office address of each officer of the bank. The Superintendent then issues an authorization certificate permitting the bank to commence business.

The trustees are required to elect from their own number a president, two vice-presidents, and such other officers as are necessary to conduct business. Each officer upon notice of elec-

tion is put under oath to administer the affairs of the bank honestly and diligently, and these oaths are subscribed to by the trustees and forwarded to the Superintendent of Banks. The persons named in the authorization certificate are the first trustees. They must be citizens of the United States; at least four-fifths of them must reside in the state, and not less than two-thirds of them in the county where the bank is located. No person is permitted to be a trustee of a savings bank if he falls under any of the following heads:

1. A person who is not a resident of the state (although in the case of New York City one-fifth of the trustees may reside in a state adjoining that city).
2. A person who has been adjudged a bankrupt, has taken advantage of the insolvency law, or has made a general assignment for the benefit of creditors.
3. A person who has not satisfied a judgment recovered against him for money outstanding for more than three months.
4. A person who is a trustee, officer, clerk, or employee in another savings bank.

CHAPTER XXVI

CHARTER CHANGES, CONSOLIDATION, AND LIQUIDATION

Increasing Capitalization of a National Bank

A national bank may, with the consent of the Comptroller of the Currency and by vote of the stockholders owning two-thirds of the shares, increase its capital stock to any sum approved by the Comptroller. Any bank contemplating such increase should advise with the Comptroller beforehand. The proposition must be formally submitted to the stockholders at a special meeting, at which shareholders who cannot attend may be represented by proxy provided that such proxy is not an officer, director, or employee of the bank. No increase of the capital stock is valid until the whole amount is paid in cash and the fact of payment certified to by the Comptroller, and until his certificate of approval is issued. Merely a portion of the increase will not be approved by him. If any assets of another bank are to be taken over in connection with the increase, an examination to determine their character and value is required, and no assets may be purchased that do not conform to law or that have unsatisfactory value.

By common law the holder of the original stock has the right to subscribe for and demand from the corporation such proportion of the new stock issued as the number of shares already owned by him bears to the whole number of shares before the increase. This right must be exercised, however, within a reasonable time. If the stock of the bank is worth more than par and the new stock is being issued at par, the shareholder who does not wish to use his right to subscribe to the new shares but wishes to protect his equity may sell to other parties his right to subscribe.

Stock dividends may not be declared, but the surplus above 20 per cent of the capital and the undivided profits may be declared as dividends, and the shareholders may then use their dividend checks to buy extra shares. To facilitate these operations authority may be obtained from the shareholders in advance of the issuance of the dividend checks to credit to the new stock the dividend upon subscriptions.

Reducing Capitalization of a National Bank

A national bank may, with the consent of the Comptroller of the Currency and of the Federal Reserve Board, and on the favorable vote of shareholders owning not less than two-thirds of the shares, reduce its capitalization to any sum not below the minimum amount required by law. Any bank contemplating such reduction should correspond with the Comptroller and the federal reserve bank before it submits the question formally to the stockholders. The application to reduce the capital should be accompanied by a letter from the federal reserve bank giving its views relative to the proposed reduction. Before passing upon the request the Comptroller may order a special examination of the bank. If the bank has sustained any losses they must be charged off, and if it has any loans which are excessive or will become excessive by reason of the reduction of the capital, they must be reduced to conform with the limitations. If any other conditions should appear unsatisfactory, the Comptroller would require their correction.

If the Comptroller approves the application, a special meeting of the stockholders is held to vote upon the question. If the vote is favorable, the reduction becomes operative upon issuance of the Comptroller's approval. Prior to that time the circulation of the bank must be reduced if it exceeds the amount of capital after reduction; this is accomplished by depositing lawful money with the United States Treasury and withdrawing an equal amount of bonds. Each shareholder has the right to participate in the re-

duction in proportion to his holdings and to receive cash for the stock surrendered, unless it was understood that the reduction was to be used to charge off losses. No part of the capital set free can be carried to surplus or to undivided profits without the unanimous consent of the shareholders. New stock certificates are issued in exchange for the old.

Extension of Charter

The law authorizes the extension of the charter of a national bank whose term is about to expire. For such extension the written consent of shareholders owning at least two-thirds of the capital stock is required, at any time within two years prior to the expiration of the existing charter. Consent may be given in person or by proxy, on special forms furnished by the Comptroller, and it is not necessary to call a shareholders' meeting for the purpose. When the requisite number have signed, the directors should hold a meeting and adopt a resolution directing the officers to certify the fact to the Comptroller. The amendment, with the appended certificate and the request for approval, should be sent to the Comptroller at least two months prior to the expiration of the charter so as to allow sufficient time for the making of the special examination required by law. The expense of this examination must be borne by the bank. If the Comptroller finds the bank in satisfactory condition, he will issue a certificate of extension. The law requires that the bank notes issued after the bank begins its new term shall bear different devices from those issued before. This necessitates the procuring of new plates, which are prepared at the expense of the bank. No transfer of bonds is necessary. The new notes are issued as the old ones are received for redemption.

Change of Name or Location

A national bank may, with the consent of the Comptroller of the Currency and by vote of shareholders owning two-thirds of

the shares, change its name or its location to any other locality in the same state not more than thirty miles distant. This vote requires a special meeting of the stockholders. A certified copy of the vote is sent to the Comptroller, and the Treasurer is authorized to transfer to the bank under its new title the bonds held by him as security for bank notes. New plates are also prepared for the notes. Removal of a bank to a different street location but within the city limits does not require any action by the shareholders or the Comptroller.

Requirements in Amending Charter

The law provides that no change shall be made in the charter of a national bank by which the rights, remedies, or security of the existing creditors of the bank will be impaired. This, by implication, authorizes amendments not contravening the rights of creditors. Such amendments require authorization by vote of shareholders owning not less than two-thirds of the stock, at a special meeting for the purpose. The law specifically provides for amendments of the charter changing the corporate title, location of the bank, increase or reduction of the capital stock, consolidation, and extension of corporate existence. These amendments require the written consent of shareholders owning two-thirds of the stock. Clauses are sometimes put in the charter authorizing amendment, in any respect not conflicting with law, by a majority stock vote. When any changes are contemplated it is best that the proposition to amend be submitted to the Comptroller in advance of action by the stockholders for his approval and specific instructions.

Reasons for Consolidation of Banks

There are many motives for the consolidation of banks. One no doubt is to allay competition. Another is to be able to offer a more varied service, as the combination of trust companies and national banks since the law has permitted national

banks to do trust business not only cuts down the overhead of conducting two institutions but also lets the consolidated institution offer its customers a more diversified service than before. Sometimes the motive for consolidation is simply the desire for enlargement. Mere size is a real factor in the success of banks, and concentrated control is much better than mere affiliation with other institutions. Our bankers are finding large size necessary, in the first place, to enter the foreign field in competition with the gigantic banks abroad, and in the second place, to handle the constantly increasing scale of domestic business, inasmuch as domestic industries are increasing in size and are operated on a higher price basis.

In England and other European countries there has been a marked tendency for banking houses to consolidate, one bank gradually absorbing others until finally enormous institutions with world-wide connections are formed. During the war the English public became alarmed at the concentration of the money power, and to allay criticism further combinations were forbidden by the government. In Canada, also, the process of consolidation is marked. In the United States during the last two years many large consolidations have taken place, particularly in New York City. To date no protest has arisen against this, but bankers realize that their consolidated control over capital must not be abused lest an aroused public put intolerable burdens upon them.

The Agreement of Consolidation

National banks proposing to consolidate should advise with the Comptroller of the Currency and apply for his approval. If the consolidation seems advisable and the terms of it are not objectionable, the Comptroller issues instructions for procedure. The directors of the two banks enter into an agreement covering the terms of the consolidation, that is, with respect to the charter to be used by the consolidated bank, the title, the capitalization,

the distribution of shares to the present stockholders of the two banks, the assets to be contributed by each and at what valuation, the disposition of such assets as are not desired for the consolidated bank, the continuance of the present boards of directors for the remainder of the year, and the provision for votes of approval by the stockholders. This agreement may provide for an increase of capitalization in excess of the aggregate capitalization of the two banks, or for payment of cash to equalize the contributions of assets of the two banks—the payment of these sums in cash to be certified to the Comptroller by the officers. If by the terms of consolidation the capitalization is reduced, it is necessary to secure the consent of the Federal Reserve Board.

The agreement having been approved by the Comptroller, signed by the directors, and acknowledged before a notary public, it is submitted to a special meeting of the shareholders of each bank, four weeks' notice having been given in the public press and a registered mail notice sent to each registered shareholder at least ten days prior to the meeting. To ratify the consolidation, the vote of shareholders owning two-thirds of the shares of each bank is required. A certificate of the ratification is sent to the Comptroller, and he then issues his certificate approving the consolidation.

Approval of Consolidation

The bonds held by either bank in excess of the amount of the capital of the consolidated bank must be withdrawn prior to approval of the consolidation by the Comptroller. These are released upon deposit of lawful money to retire the outstanding circulation. The other bonds of the two banks lodged with the United States Treasury will be transferred to the consolidated bank for security for its notes.

If some shareholder objects to the terms of the consolidation, he may, by giving notice to the directors of his bank within twenty days of the approval of the consolidation by the Comp-

troller, be entitled to receive the value of his shares, ascertained by a committee of three persons, one representing the directors, one the shareholders, and the third chosen by these two. In case the shareholder is not satisfied with this appraised value, he may appeal to the Comptroller for final determination. These shares are then sold at public auction.

Methods of Consolidation

Consolidation may be effected by placing one or both of the banks in liquidation, to which end three methods are in use:

1. Without an increase of the capital the directors of the absorbing bank may contract with the directors of the liquidating bank to purchase its assets, assume its liabilities, and pay the value of assets purchased in excess of liabilities, less any expenses incident to liquidation.

2. By increasing the capitalization of the absorbing bank by an amount equal to that of the liquidated bank the additional shares may be sold to stockholders of the latter. This requires the previous consent of the stockholders of the absorbing bank. The directors of the absorbing bank then proceed to contract for the purchase of the assets and the assumption of the liabilities of the liquidated bank.

3. Having first placed both the interested banks in voluntary liquidation, the interested officers may proceed to organize a new bank under a different corporate title and acquire the business of the liquidating banks.

In any of these three methods there should be a contract covering the transfer of assets and assumption of liabilities, and an examination of the assets to be taken over will be made by a national bank examiner at the expense of the bank acquiring the assets. The bonds of the liquidating bank, deposited with the United States Treasury for security for its bank notes, are assigned to the acquiring bank, which assumes responsibility thereafter for the outstanding notes.

Liquidation of National Banks

National banks may be liquidated voluntarily during the term of their charter or at the expiration of it, or the liquidation may be compulsory because of dissolution for violation of the National Bank Law, the violation being determined by a proper court in a suit brought by the Comptroller of the Currency.

Voluntary liquidation may come by vote of the owners of two-thirds of the stock. Before calling a meeting of the stockholders for this purpose, the directors should advise with the Comptroller. The shareholders should also be given the notice required by the charter for such meeting. If the stockholders vote for liquidation, this fact is certified to the Comptroller and is published for two months in New York City and also in the place where the bank is located. Creditors are notified to present notes and other claims against the bank for payment. To provide for the redemption of outstanding bank notes lawful money must be deposited within six months from date of liquidation.

The affairs of the liquidating bank pass into the hands of its shareholders for such legal disposition as may seem proper. It is usual for the shareholders to adopt a resolution providing for the appointment of a liquidating agent or committee and requiring that agent or committee to make quarterly reports to the Comptroller showing the progress of the liquidation until it is completed. If no such agent is appointed, the settlement of affairs devolves upon the directors. After a bank has gone into liquidation the powers of the officers to transact any business except that necessarily involved in winding up the bank's affairs are terminated, unless such authority is expressly conferred by the shareholders. The bank may continue to elect officers and directors for the purpose of effecting liquidation, but the stock is no longer transferable to enable the transferee to help elect or be himself a director.

A creditor of a liquidating bank has the right to enforce the individual double liability of shareholders for debts of the bank by filing in the proper United States court a bill in equity in the

nature of a creditor's bill against the shareholders. Any shareholder who is dissatisfied with the way in which the liquidation is conducted has the right to go into court and ask the appointment of a receiver, just as a shareholder of any state corporation.

When the charter of a national bank has expired or is about to expire and the bank has failed to secure an extension, it proceeds to liquidation in the same manner as if the shareholders had voted to go into liquidation, and the franchise is extended for the sole purpose of liquidating. It is always best to call a meeting of the shareholders at that time to determine what action is deemed advisable for closing the bank's affairs. The fact that the charter has been permitted to expire should be certified to the Comptroller, and notice of expiration of its corporate existence must be published for two months in New York City and locally. The affairs of the bank are then liquidated in the same manner as if the shareholders had voted voluntary liquidation.

Conversion of a National Bank into a State Bank

If a national bank has authority to dissolve it may incorporate under state law. The dissolution is carried out under the national law. Consent in writing of the holders of two-thirds of the capital stock must be obtained in order to make the dissolution effective. A majority of the directors must subscribe and acknowledge an organization certificate. The stockholders' consent and resolution must fix the date when the dissolution as a national bank becomes effective, and they must be filed with the Superintendent of Banks of the state (using New York as an example) before the date of dissolution in order that he may make the required investigation. If all details are complied with and the investigation results favorably, the Superintendent of Banks indorses the organization certificate. As soon as the capital stock has been paid, the required securities deposited with the Superintendent, and the authorization certificate issued, the corporate existence of the state bank begins.

INDEX

A

- Accommodations,
 - as a dependable source for loans, 394
 - from reserves, 390
- Act of 1913 (See "Federal Reserve Act")
- Advisory council, federal reserve system, 290
- Affiliated banks, foreign branches for, 302
- Agents (See "Federal reserve agent"; "Fiscal agents")
- Aldrich plan, 237
- Aldrich-Vreeland Act of 1908, 237
 - amendments 1914, 317
 - associations under, 313
 - character of emergency notes, 316
 - collateral of national currency associations, 314
 - extension by Federal Reserve Act, 317
 - note issues under, 314, 315
 - pledge of commercial paper, 314
 - security for issues by banks, 315
 - taxes on issues, 319
- American Foreign Banking Corporation, ownership of, 303
- Application to organize national bank, 470
- Articles of association, national banks, 472
- Assets,
 - federal reserve banks, 275
 - note issues based on, 226
- Associations,
 - building and loan, 446-449

- Associations—*Continued*
 - national farm, 465
 - under Aldrich-Vreeland Act, 313
- Authorization certificate,
 - state banks, 480
 - trust company, 482
- Availability, definition of, 420

B

- "Baltimore plan," 236
- Bank balances, decentralization of, in central reserve cities, 407
- Bank notes (See also "Federal reserve notes"; "National bank notes")
 - based on general assets, 226
 - first Bank of the United States, 214
 - issues of before Civil War, 226
 - second Bank of United States, 216
 - state bank issues,
 - based on state credit, 228
 - bond security system, 227
 - evils of early issues, 228
 - Suffolk redemption system, 226
- Bank of North America, history of, 222
- Banking system, United States,
 - composition of, 426
 - statistics, 441
- Banks (See also special kinds, as "Federal reserve banks"; "National banks"; etc.)
 - country, effect of cessation of interest on reserves on, 409
- Bond deposits,
 - amount of national bank notes issuable, 325

Bond deposits—*Continued*

bonds having circulation privilege,
327

Comptroller's records of, 326

conversion of bonds, 319

disposition of bonds at withdrawal
of circulation, 333

handling of, 325

national bank note issues, 325

requirements of,

Act of 1864, 311

Act of 1870, 311

Act of 1874, 312

Act of 1882, 312

Act of 1900, 313

Aldrich-Vreeland Act 1908, 313
repealed under Federal Reserve

Act, 319

sale of bonds to federal reserve
banks, 319

withdrawal of national bank notes,
325

Bonds,

federal farm loan, 463

postal savings used to buy, 444

volume of circulating bank notes
dependent on price of, 342

Boston Country Clearing House,
420

Branches,

domestic, 296-300

affiliated institutions as substi-
tutes for, 299

Canadian and English, 296

development in United States,
299

effect on competition, 299

federal reserve banks, 243

located in home city, 299

national bank, 297

state bank, 297

federal land bank, 463

federal reserve bank, 241

agencies as substitutes for, 243

Branches—*Continued*

federal reserve bank—*Continued*

domestic branches established,
243

foreign branches, 244

types of organization of, 243

foreign,

charters of affiliated banks
having, 302

European banks, 300

Federal Reserve Act, 301

functions of, 304

growth of, 304

management of, 304

national bank subscriptions
limited, 303

national banks having, 301

procedure for establishing, 301

subsidiary corporation to con-
duct, 302

versus affiliated foreign banks,
304

national banks, 297

second Bank of the United States,
219

state banks, 297, 429

Building and loan associations, 446-
449

contributions, 447

By-laws, national bank, 473

C

Call loans (See "Loans")

Canada, branch banks in, 296

Capital,

building and loan associations, 447

federal reserve banks, 258, 279

national bank, 471, 474

increases and decreases, 487

state banks, 427

Cattle loan companies, 457-461

Central reserve cities, 388 (See also
"Reserve cities")

- Central reserve cities—*Continued*
 concentration of reserve balances
 in New York, 391
 concentration of reserves in, 391
 Central reserve city bank, reserves in,
 407
 Certificate of organization,
 national banks, 472
 state banks, 480
 trust companies, 482
 Charter,
 federal, advantages of, in foreign
 trade, 306
 national bank,
 amendment, 489
 extension of, 489
 Charter bonds, repeal of, 475
 Chase, S. P., scheme for national
 banks, 231
 Circulation, bonds having note issue
 privilege, 327
 Classification,
 financial institutions, 211
 state institutions, 211
 Clearing houses,
 federal reserve banks as, 279, 420
 under federal reserve system, 408
 Collateral,
 Aldrich-Vreeland Act, forms, 313,
 318
 federal reserve note, 351, 355
 New York bank loan, distribution
 of, 396
 protecting federal reserve notes, 350
 Collections,
 federal reserve banks, 279
 out-of-town (country),
 changes in, under federal reserve
 system, 408
 relation to reserves, 396
 par collections, 420-422
 services of correspondents, 390
 Commercial paper,
 definition of eligible paper, 374
- Commercial paper—*Continued*
 open market for, 378
 rediscounting control, 367
 rediscounts, federal reserve banks,
 374-380
 Comptroller of the Currency,
 bank examinations by, 293
 custody of deposited bonds, 325
 issues blanks for bank notes, 328
 member of Federal Reserve Board,
 292
 office of, 291
 powers of, 291
 powers under Federal Reserve Act,
 292
 Consolidation,
 growth of in foreign countries, 490
 national banks, procedure, 490-492
 Conversion,
 bonds under Federal Reserve Act,
 319
 deposit bonds, 320
 gold notes, 320
 Liberty loans stop, 321
 national bank into state bank, 494
 state bank into national bank, 477
 state bank into trust company, 483
 trust company into state bank,
 483
 Corporations, under Edge Act, 305-
 310
 Correspondents,
 competition for reserve balances,
 392
 definition of, 389
 federal reserve decentralized bal-
 ances, 407
 federal reserve reduced need for,
 408
 relation to reserves, 388
 services as collection agents, 390
 services of, 390
 Costs, operating, of federal reserve
 banks, 260

- Country collections (See "Collections, out-of-town")
- Credit, federal reserve bank, 385
- Currency (See "Bank notes")
- D**
- Debts, bank notes dependent on government, 342
- "Demand" deposits, 409
- Departments, federal reserve banks, 271-275, 413
- Depositories, United States funds, federal reserve banks as agent for, 280
- Deposits (See also "Bond deposits")
- interest paid on, 390
 - postal savings, 444
 - reserves against,
 - under Federal Reserve Act, 400-425
 - under National Banking Act, 387-399
 - savings, 437
 - in national banks, 256
 - total amount in United States, 422
 - United States government,
 - in federal reserve banks, 279-283
 - in second Bank of United States, 216
- Direct issue, federal reserve notes for gold, 354-357
- Directors,
 - Edge corporations, 307
 - federal reserve banks, 262
 - election of, 263
 - federal reserve agent, 264
 - qualifications of, 263
 - national bank, 473
 - state banks, 481
 - trust company, 482
- Discount rates,
 - federal reserve bank, 380
 - as affected by gold market, 383
- Discount rates—*Continued*
- federal reserve bank—*Continued*
 - clearing house deposit rates, 384
 - control by lines of credit, 385
 - control policy of Federal Reserve Board, 382
 - effect of war loans on, 382
 - factors determining policy, 382
 - favor short-term paper, 384
 - legislation to regulate, 383
 - preferential rates established, 384
 - relation to market rate, 384
 - schedules of rates of, 381
 - operations of federal reserve bank, 374-386
- Districts,
 - federal reserve, 238-244
 - map of, 242
- Domestic exchange,
 - drafts on federal reserve banks, 418
 - gold settlement fund, 413-417
 - telegraphic transfers, 417
- Drafts, drawn on federal reserve banks, 418-420
- E**
- Earnings, federal reserve bank, 259-261
- Edge Act,
 - directors of corporations under, 307
 - establishment of corporations under, 309
 - factors promoting success of corporations under, 309
 - national banks own stock of corporations under, 307
 - powers of corporations under, 308
 - provisions of, 305, 307
 - purposes of, 305
 - relation to McLean Act, 305
 - types of corporations under, 307

- Elasticity,
 federal reserve notes, 369-373
 national bank notes, 342-345
 tax on deficiency of reserves, 360
- Emergency circulation, under Aldrich-Vreeland Act, 313-319
- Employees, federal reserve bank, 269
- England, branch banks in, 296
- Examinations,
 by federal reserve bank, 293
 by Federal Reserve Board, 293
 Comptroller of the Currency, 291, 293
 effect upon banks, 295
 examiners classified, 294
 organization for, 294
 reports of, 294
- Exchange (See "Domestic exchange")
- Exchange drafts, 419
- Expansion, restraint of, by control of discount rates, 385
- Expenses, federal reserve bank, 260
- F**
- Farm loans, federal system, 461-468
- Federal Advisory Council, 290
- Federal Farm Loan Board, 468
- Federal farm loan system, 461-468
- Federal land banks, 462
 bonds of, 463
 branches, 463
- Federal Reserve Act,
 amendment providing direct issue, 354
 amendment to permit subscriptions to foreign bank stock, 303
 foreign branch provisions, 301
 passage of, 237
- Federal reserve agent,
 collateral deposited with, 350, 355
 duties of, 264
- Federal reserve banks,
 act as clearing houses, 279
 bank notes, 320
 branches of, 241-244
 buildings for, 278
 capital, paid-in, 279
 capitalization of, 258
 collection items, 279
 control of money rates, 278
 criticism of, 239
 departments of, 271-275
 deposits of as liabilities, 279
 directors of, 262-265
 discount operations, 374-386
 discount rates, 380
 drafts drawn in, 418-420
 earnings of, 260
 earning assets, 277
 employees of, 269
 gold concentration by, 352-354
 governor of, 267, 269
 liabilities, 279
 lines of credit to restrain expansion, 385
 member banks, rediscounting, 375
 New York, organization of, 265
 officers of, 267-270
 open market for discounts, 378
 operating costs of, 260
 organization, 265
 par collections, 420
 powers of, 270
 rediscount operations, 374-386
 reserves against deposits, 400-425
 resources, 275
 responsibility for stemming inflation, 367
 subtreasuries taken over by, 284
 surplus funds, 259
- Federal Reserve Board, 285-295
 adjustment of reserves, 321
 administrative duties of, 289
 constitution of, 286
 control of excessive issues, 366

- Federal Reserve Board—Continued**
 discount policy, 382
 expenses of, 289
 may impede inflation, 366
 membership of, 285
 organization of, 288
 powers of, 287, 368
 relation to member banks, 368
 responsibility for stemming inflation, 367
 restriction on paper eligible for rediscount, 366
 retires national bank notes, 322
 rules and regulations of, 289, 368
- Federal reserve notes, 319, 350-373**
 characteristics of, 364
 collateral, 351, 355
 custody of, 358
 direct issue for gold, 354-357
 elasticity of, 369-373
 established to replace national bank system, 350
 excessive issues, 366
 gold deposits, 352-354
 interest rates may be charged, 366
 issue of, 350
 Liberty bonds stopped refunding and conversion of bonds, 321
 methods of issue and redemption, 320, 352
 note liabilities, 279
 proportion of gold and paper collateral, 356
 redemption of, 320, 352
 reserve against, 357
 reserve deficiencies, 359-362
 retirement of, 352
 safety of, 369
 secured by silver certificate under Pittman Act, 324
 simplification of our currency by, 392
 substitution of collateral for, 350
- Federal reserve notes—Continued**
 suspension of reserve requirements, 359
 tax on deficiency of reserves for, 359
 under Pittman Act, 324
 unissued, 351
 use as reserves, 365
- Federal reserve system,**
 advisory council, 290
 decentralization of bank balances, 407
 districts, 238-244
 fiscal agents of United States, 280
 membership in, 245-257
 organization committee, 239
 origin of, 236
 reserves against deposits, 400-425
- Fictitious reserve, 396**
- Fiduciary,**
 Federal Reserve Act powers, 254
 power of national bank as, 253
- First Bank of United States, history**
 and organization of, 212-215
- Fiscal agents,**
 duties of, 280
 federal reserve banks as, 280
 government balances in, 281
 supplanting Independent Treasury, 282
- "Float," explanation of, 396**
- Foreign trade, financing of, 300-310**
- Free gold, definition of, 362**
- G**
- Gold,**
 collateral for federal reserve notes, 354
 concentration of, 352
 effect of discount rates on, 383
 embargo, 383
 federal reserve deposits, 352
 reserves in federal reserve banks, 357

- Gold banks,
 - cessation of, 312
 - establishment of, 311
- Gold settlement fund, 413-417
 - use in handling domestic exchange, 418
- Gold Standard Act of 1900, 236
- Government debts, volume of national bank notes dependent on, 342
- Governor, federal reserve bank, 269

I

- Independent Treasury (See "United States Treasury")
- Indianapolis Currency Commission reform of national bank system, 236
- Inflation,
 - federal reserve board may impede, 366
 - responsibility for stemming, 367
- Interest,
 - on reserve balances, ceased, 409
 - paid on bank deposits, 390
 - effect of, 392
 - paid on postal savings deposits, 444
- Interest rates,
 - control by federal reserve bank, 278
 - on federal reserve notes, 366
- International Acceptance Bank, Inc., ownership of, 303

J

- Joint-stock land banks, 466
- Joint-stock savings banks, 437

L

- Land banks, 462, 466
- Lawful money, defined, 331

- Legal tender,
 - bank notes as, 329
 - substitutes for gold to obviate deficiency reserves, 361
- Liabilities, federal reserve banks, 279
- Liberty bonds, effect on bond refunding and conversion, 321
- Lines of credit, federal reserve bank, 385
- Liquidation,
 - national banks, 493
 - provisions for national bank notes at, 333
- Livestock, cattle loan companies, 457-461
- Loan associations (See "Building and loan associations"; "Cattle loan companies")
- Loan shark, 450-453
- Loans,
 - call, collateral stock exchange, 395
 - cattle loan companies, 457-461
 - control of, 368
 - direct, 396
 - distribution of, New York branch, 395
 - federal farm, 461-468
 - interest rates during war, 382
 - remedial, 453
 - state banks, 428

M

- Market (See "Open market")
- Member banks,
 - amount and distribution of reserves, 402-405
 - balances maintained with federal reserve bank, 421
 - calculation of reserve against deposits, 409
 - drafts drawn on federal reserve banks, 418
 - lines of credit for, 385

- Member banks—*Continued*
 par collections, 421
 rediscounting for, 374
 reserve balance carried in federal reserve bank, 411
 reserve reports, 411
 responsibility for stemming inflation, 367
- Membership,
 federal reserve bank, capital contributions, 258
 Federal Reserve Board, 285
 federal reserve system,
 growth in state bank, 248
 ineligible institutions, 250
 national bank, 245
 objections to, 250
 procedure in applying for, 247
 reasons for, 251
 relations between members and federal reserve bank, 252
 state banks, 246-252
 trust companies, 246
- Mercantile Bank of the Americas,
 liberal charter of, 302
- "Money committee" control of interest rates, 278
- Money, lawful, 331
- Money market, control of, by federal reserve banks, 278
- Morris plan banks, 450-457
- Mortgages, federal farm loans, 463
- Mutual savings banks, 437
 organization, 483
- N
- National Association of the Supervisors of Banks, purposes of, 430
- National bank notes,
 advantages of, 336
 advertising value of, 338
 basis for pyramiding credit, 329
- National bank notes—*Continued*
 bond deposits, 311
 confidence in, 338
 cost of redemption of, 332
 denominations of, 329
 dependent upon government debts, 342
 disadvantages, 342-349
 elasticity vs. deposits, 346
 geographical distribution, 311, 346
 inelasticity, 342, 345
 legal-tender qualities of, 329
 legislative influence on, 344
 limitation of issues, 311
 limitation on reduction, 312
 method of withdrawal from circulation, 332
 orders for, 328
 origin of, 230
 printing of, 328
 profits from, 338, 342
 provisions for, at liquidation, 333
 provisions of Aldrich-Vreeland Act, 313
 redemption fund, 330-332
 redemption methods, 331
 redemption of defaulted, 335
 reduction of circulation, 312
 reduction of tax on, 316
 relationship with Treasury, 338
 replaced by federal reserve issues, 350
 requirements, 325
 retirement of, 319, 322
 shipment of notes for redemption, 331
 signatures on, 328
 tax on circulation reduced, 313
 withdrawal of, 325
- National Banking Act, 232
- National banks,
 Aldrich plan, 237
 Aldrich-Vreeland Act of 1908, 237

- National banks—*Continued*
 application to organize from
 Comptroller, 470
 articles of association, 472
 as fiduciary, 253
 as insurance agent, 252
 as real estate loan broker, 253
 Baltimore plan, 236
 by-laws, 473
 capital, 471
 decrease of, 487
 increase of, 486
 capital stock subscriptions, 474
 change of location, 488
 change of name, 488
 charter, 475
 amendments, 489
 extension, 488
 circulation privileges, 475
 competition with state banks, 252
 concentrated reserves in, 391-394
 consolidation of,
 procedure, 490-492
 stockholders, 491
 conversion into state bank, 494
 conversion of other kinds into, 477
 directors, 473
 distribution, 442
 domestic branches, 297
 Edge Act and, 307
 Federal Reserve Act passed, 237
 foreign branches, 301
 growth of, 232-235
 initial surplus, 474
 liquidation of, 493
 members of federal reserve system,
 245
 officers, 473
 organization,
 blanks for, 472
 certificate, 472
 procedure for, 469
 powers under Federal Reserve Act,
 252
- National banks—*Continued*
 prohibited from buying another,
 296
 real estate loans, 256
 reduction of circulation, 312
 reform movement, 235
 reorganization of other kinds into,
 475
 reports of, 294
 reserve against deposits, 387
 savings deposits, 256
 subscriptions to federal reserve
 bank stock, 474
 subscriptions to foreign bank stock,
 303
 National currency associations, 313
 National farm loan associations, 465
 New York Federal Reserve Bank,
 organization of, 265
 Form, 268
- O
- Officers,
 federal reserve banks, 267-270
 national bank, 473
 Open market,
 discounts, 378
 operations of federal reserve banks,
 effects of, 379
 Organization,
 federal reserve bank, 265
 mutual savings bank, 483
 national bank, 469-475
 state bank, 478-481
 trust company, 481
- P
- Panic of 1837, 224
 Paper (See "Commercial paper";
 "War paper")
 Par collections, 420-422
 Phelan Act, amendment to Federal
 Reserve Act, 254

- Pittman Act of 1918, 323
 Postal savings banks, 443
 Powers,
 Comptroller of the Currency, 291
 federal reserve bank, 270
 Federal Reserve Board, 287
 national banks, 252
 Private banks, 425-437
 reorganization into national bank,
 475
 Profits,
 on bank notes, 342
 on note circulation, 339
 Purchases, commercial paper, 374
- R
- Rates (See "Discount rates"; "Interest rates")
 Ratio,
 federal reserve notes to gold
 reserve, 362
 reserve funds, 362-364
 Real estate, loans on, by national
 banks, 256
 Redemption,
 bank notes,
 cost of, 332
 defaulting, 335
 failure to redeem, 334
 second Bank of the United
 States, 220
 federal reserve notes, 352
 second Bank of United States, 220
 Suffolk bank system of, 226
 Redemption fund,
 national bank note, 330-332
 remittance for credit of, 330
 shipment of, to Treasury, 331
 Rediscounts, federal reserve bank,
 374-386
 between reserve banks, 379
 discount rates, 380
 maturity of, 378
- Rediscounts, federal reserve banks—
 Continued
 member banks, 374
 number of banks accommodated,
 376-378
 open market, 378
 promoted by the war, 375
 relative activity of, 376
 restrictions on, 366
 seasonal variations, 376
 war paper vs. commercial, 375
 Refunding, deposit bond (See "Con-
 version"; "Retirement")
 Remedial loans, corrective of loan
 sharks, 453
 Reorganization, bank into national
 bank, 475 (See also "Conver-
 sion")
 Reports,
 examiners', 294
 national bank, 294
 Reserve,
 adjustment as between banks, 361
 character of,
 under Federal Reserve Act, 413
 under National Banking Act, 393
 chart of federal reserve bank re-
 serves, 363
 custody of, 358
 deficiency in, 359-362
 deposits in federal reserve banks,
 location of, 413
 deposits in national banks,
 character of, 393
 concentration of, 391-394
 correspondents, 388
 decentralization of, 399
 direct loans by interior banks, 396
 effect of concentration on stock
 market, 392
 fictitious, 396
 "float," 396
 gross vs. net deposits, 397
 minimum legal requirements, 398

Reserve—*Continued*

- deposits in national banks—*Cont'd*
 - purposes of correspondent bal-
ances, 390
 - redeposited, 388
 - relation to country collections,
396
 - relation to stock exchange loans,
395
- deposits under federal reserve,
 - Act of 1917, 401
 - Act of 1918, 401
 - against demand, 410
 - against time, 411
 - amendment of 1916, 401
 - central reserve cities, 401
 - concentration of, 407
 - decentralization of bank bal-
ances, 407
 - distribution of, 402
 - effect of, 402
 - impairment of, 421
 - interest payment on, ceases, 409
 - legal minimum percentages of,
402
 - location of, 400
 - penalties for impairment of, 411
 - provisions of Act of 1913, 400
 - reduction of, 402
 - reports of, 411
 - requirements, 402, 413
 - reserve cities defined, 411
 - time requirements, 400
- effects of federal reserve system on,
402
- excess, 362
- federal reserve banks, 277, 357-364
- federal reserve notes as, 365
- free gold defined, 362
- gold, federal reserve banks, 352,
357
- government deposits, 362
- minimum,
 - under Federal Reserve Act, 402

Reserve—*Continued*

- minimum—*Continued*
 - under National Banking Act,
384, 398
- obviating deficiencies of, 360
- redemption fund as, 358
- requirements,
 - suspension of, 359
 - trust companies, 432
 - under Federal Reserve Act, 413
 - under National Banking Act,
387
- reserve ratio, 362-364
- secondary, 395
- state banks, 429
- substitution of legal tenders for
gold, 361
- tax on deficiency of, 359
- trust companies, 432
- under National Banking Act, 387-
399
- war paper, effect on, 364
- Reserve cities, 387 (See also "Cen-
tral reserve cities")
 - defined, 411
 - list of, 412
 - qualifications of, 413
- Reserve city banks, reserve against
deposits, 400
- Resources, federal reserve banks, 275
- Retirement,
 - federal reserve notes, 352
 - national bank notes,
Federal Reserve Board policy,
322
 - provisions for, 319
 - stopped by Liberty Loans, 321

S

- Savings in United States, 449
- Savings banks,
 - history of, 437
 - joint-stock, 437

- Savings banks—*Continued*
 mutual, 437
 distribution of, 439
 organization of, 484
 postal, 443
 school, 445
- Savings deposits (See "Deposits")
- Second Bank of the United States,
 history and organization, 216-
 222
- Signatures, national bank note, 328
- Silver,
 purchases under Pittman Act, 324
 sales under Pittman Act, 323
- Silver certificates, withdrawn under
 Pittman Act, 323
- Silver dollars, reduction of, 324
- Species circular of 1836, 224
- State banks,
 authorization certificate, 480
 Bank of Massachusetts, 222
 Bank of New York, 222
 Bank of North America, 222
 branches, 297, 429
 capital requirements, 427
 controversy with second Bank of
 United States, 218
 conversion into national bank, 477
 conversion into trust company, 483
 conversion of national bank into,
 494
 development from 1811 to 1816,
 223
 development to 1811, 222
 directors, 481
 distribution, 442
 effect of panic of 1837 on, 224
 effect of second Bank of United
 States on, 223
 growth of, 426
 limitation, 428
 members of federal reserve system,
 245-252
 note issues, 227, 228
- State banks—*Continued*
 note issues prior to 1861, 226
 notice of intention to organize, 479
 organization certificate, 479
 organization procedure, 478-481
 reorganization into national bank,
 475
 reserve requirements, 429
 supervision of, 430
- State institutions, classification of,
 211
- Statistics, banking system of United
 States, 439
- Stock exchange call loan, 395
- Stock, national bank, 474
- Stockholders, of consolidation, 491
- Subsidiary banks, 299
- Sub-treasuries,
 taken over by federal reserve
 banks, 284
 United States, 283, 284
- Suffolk Bank, redemption system of,
 226
- Superintendent of banks, functions,
 430
- Supervision, state banks, 430
- Surplus funds,
 federal reserve banks, 259
 as liabilities, 279
 national banks, 474
- T
- Tax on circulation, national bank
 notes reduction, 313, 316
- Tax on federal reserve notes, defi-
 ciency of, 359
- Tax on national bank note,
 levy of, 335
 methods of payment, 336
- Telegraphic transfers, federal reserve
 facilities, 417
- "Time" deposits, 409
- Transfer drafts, 419

- Treasury (See "United States Treasury")
- Trust (trustee) (See "Fiduciary")
- Trust companies,
authorization certificate, 482
conversion into national bank, 477
conversion into state bank, 483
conversion of state bank into, 483
deposited securities, 482
directors, 482
failures of, 435
growth of, 431-434
legal requirements of, 431
losses to depositors in, 435
organization certificate, 482
organization of, procedure, 481
percentage reserves carried 1890-1913, 434
- Trust companies—*Continued*
reserve requirements, 432
supervision of, 434
- Trustees, mutual savings banks, 484
- U
- United States Treasury,
founding of, 225
sub-treasuries, 283, 284
weaknesses of, 282
- W
- War paper,
effect on reserve ratio, 364
increase of, 367
not commercial, 374
- Withdrawal, national bank from
circulation, 332

