

LUBRICATION

ORDER

26 MARCH 1971 (Supersedes LO5-3810-201-12-2, dtd 9 Feb 1968 and LO5-3810-206-12-2, dtd 18 Mar 1968)

LO5-3810-206-12-2

**CRANE-SHOVEL, BASIC UNIT, CRAWLER MOUNTED, 40 TON, 2 CU YD
DIESEL DRIVEN, (HARNISCHFEGER MODEL 855 BG, 855 BG-2 AND
855 BG-3) W/HARNISCHFEGER ENGINE MODEL 687C-18-ES AND
CATERPILLAR ENGINE MODELS D333TA AND D333C**

Reference LO5-3810-206-12-1, -3, -4 and 5 C9100-IL

Intervals are based on normal hours of operations. Adjust to compensate for abnormal operations and severe conditions. During inactive periods sufficient lubrication must be performed for adequate preservation.

Clean parts with SOLVENT, dry-cleaning, or with OIL, fuel, Diesel. Dry before lubricating.

Clean fittings before lubricating.

Lubricate points indicated by dotted arrow shafts on both sides of equipment.

A dotted circle indicates a drain below.

Relubricate after washing or fording.

Drain crankcases when hot. Fill and check level

FOLD

FOLD

LUBRICANT • INTERVAL

Fan Hub
(sealed bearings no lubrication required)

Crankcase Fill Cap
(See Key.)

Oil filters
(See key) (Disassemble, clean housing and renew element) (See note 4.)

Crankcase Drain Cock
(Drain and refill)

Crank level Dip-Stick
(Check level)

CAUTION: When OES oil is used the level will be checked more often.

Starter Inbound Bearing
(Remove motor and fill oil cup located inside case) (Sparingly)

INTERVAL • LUBRICANT

Pierce Governor Drive Gear

Generator
(Sealed bearings no lubrication required.)

Oil filter Drain Plugs
(Drain sediment every 50 service hours)

Starter Outboard Bearing
(Sparingly)

Air Cleaner
(See key) (Check and refill oil reservoir to level mark) (Every 50 service hours, disassemble entire unit, clean, fill and reassemble.)

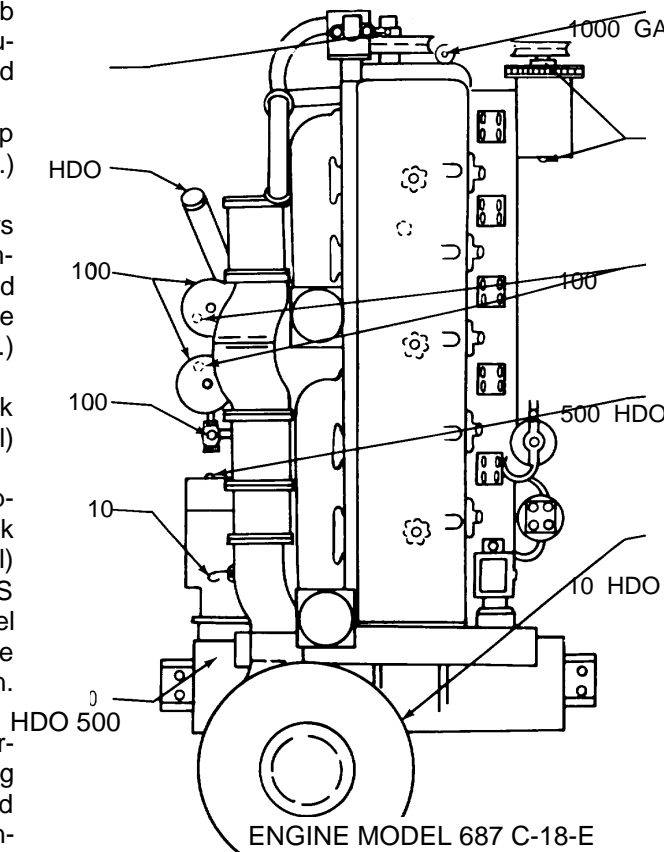

ENGINE MODEL 687 C-18-E

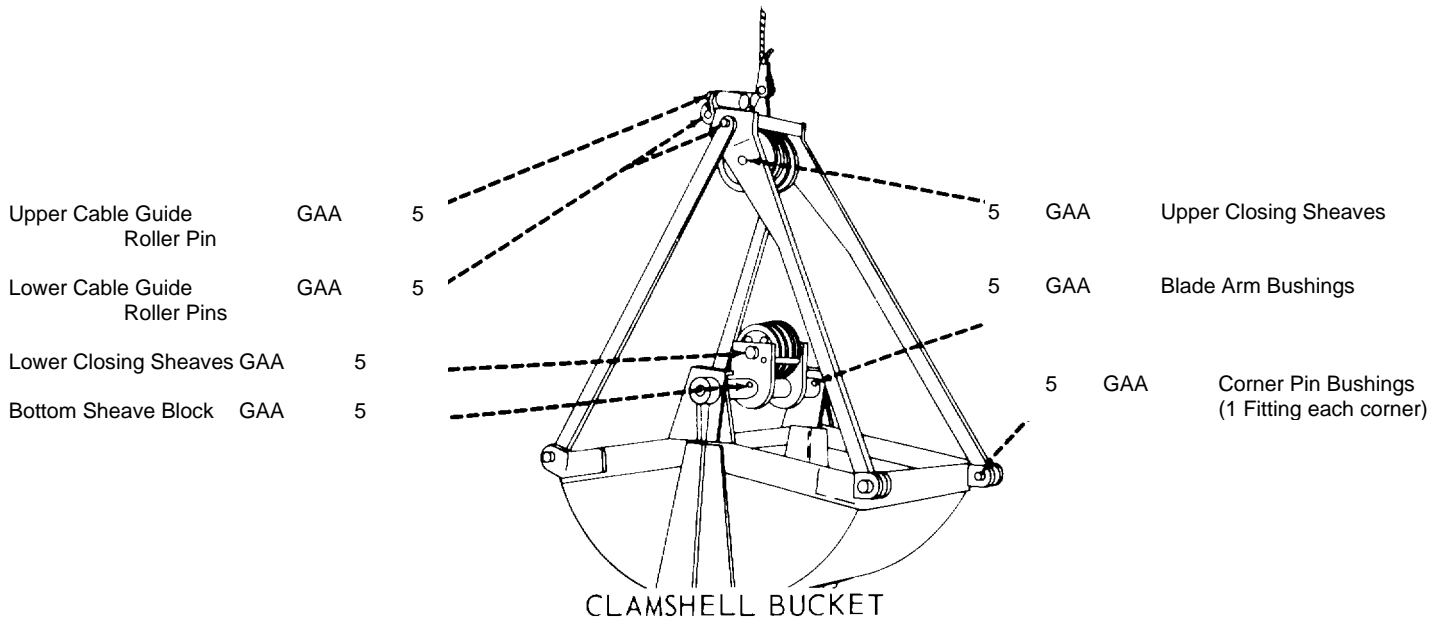

FOLD

FOLD

- KEY -

LUBRICANTS	CAPICITY	EXPECTED TEMPERATURES			INTERVALS
		ABOVE +32° F	+40° F TO -10° F	0° F TO -65° F	
HDO-OIL, Engine, Heavy Duty	34 qts	HDO 30	HDO 10	OES	Intervals given are in hours of normal operations
Crankcase w/ Filters					
Oil Can Points					
Air Cleaner					
OES-OIL, Engine, Sub-zero	4 1/2 qts	ALL TEMPERATURES			
GAA-GREASE, Automotive and Artillery					

NOTES:

- FOR OPERATION OF EQUIPMENT IN PROTRACTED COLD TEMPERATURES BELOW 10° F.**
Remove lubricant prescribed in the key for temperature above 10° F. Relubricate with lubricants specified in the key for temperatures below 10° F.
- OIL CAN POINTS.** Every 10 service hours lubricate all linkage, pins and clevises with HDO.
- CABLES.** Keep cables clean and lubricated with HDO. **CAUTION: Do not lubricate cables coming in contact with excavated materials.**
- ENGINES OIL FILTERS.** Every 100 hours remove filter element, clean housing, install new element, fill crankcase, operate engine for five minutes, check for leaks.

5. LUBRICANTS. The following is a list of lubricants with the Military Symbols and applicable specification numbers.
OES MIL-L-10295 GAA MIL-G-10924 HDO MIL-L-45199

Copy of this Lubrication Order will remain with the equipment at all times; instructions contained herein are mandatory.

BY ORDER OF THE SECRETARY OF THE ARMY:

W.C. WESTMORELAND
General, United States Army,
Chief of Staff

OFFICAL:

KENNETH G. WICKHAM
Major General, United States Army,
The Adjutant General

RECOMMENDED CHANGES TO EQUIPMENT TECHNICAL PUBLICATIONS



THEN... JOT DOWN THE DOPE ABOUT IT ON THIS FORM, CAREFULLY TEAR IT OUT, FOLD IT AND DROP IT IN THE MAIL!

SOMETHING WRONG WITH THIS PUBLICATION?

FROM: (PRINT YOUR UNIT'S COMPLETE ADDRESS)

DATE SENT

PUBLICATION NUMBER

PUBLICATION DATE

PUBLICATION TITLE

BE EXACT... PIN-POINT WHERE IT IS

PAGE NO.

PARA-GRAPH

FIGURE NO.

TABLE NO.

IN THIS SPACE TELL WHAT IS WRONG AND WHAT SHOULD BE DONE ABOUT IT:

TEAR ALONG PERFORATED LINE

PRINTED NAME, GRADE OR TITLE, AND TELEPHONE NUMBER

SIGN HERE:

DA FORM 2028-2
1 JUL 78

PREVIOUS EDITIONS ARE OBSOLETE.

P.S.—IF YOUR OUTFIT WANTS TO KNOW ABOUT YOUR RECOMMENDATION MAKE A CARBON COPY OF THIS AND GIVE IT TO YOUR HEADQUARTERS.

PIN: 029962

This fine document...

Was brought to you by me:



[Liberated Manuals -- free army and government manuals](#)

Why do I do it? I am tired of sleazy CD-ROM sellers, who take publicly available information, slap “watermarks” and other junk on it, and sell it. Those masters of search engine manipulation make sure that their sites that sell free information, come up first in search engines. They did not create it... They did not even scan it... Why should they get your money? Why are not letting you give those free manuals to your friends?

I am setting this document FREE. This document was made by the US Government and is NOT protected by Copyright. Feel free to share, republish, sell and so on.

I am not asking you for donations, fees or handouts. If you can, please provide a link to liberatedmanuals.com, so that free manuals come up first in search engines:

<A HREF=<http://www.liberatedmanuals.com/>>Free Military and Government Manuals

– Sincerely
Igor Chudov
<http://igor.chudov.com/>