

G H 65606

HARVARD UNIVERSITY.



LIBRARY

OF THE

MUSEUM OF COMPARATIVE ZOOLOGY

50,938

Exchange.

December 12, 1918.

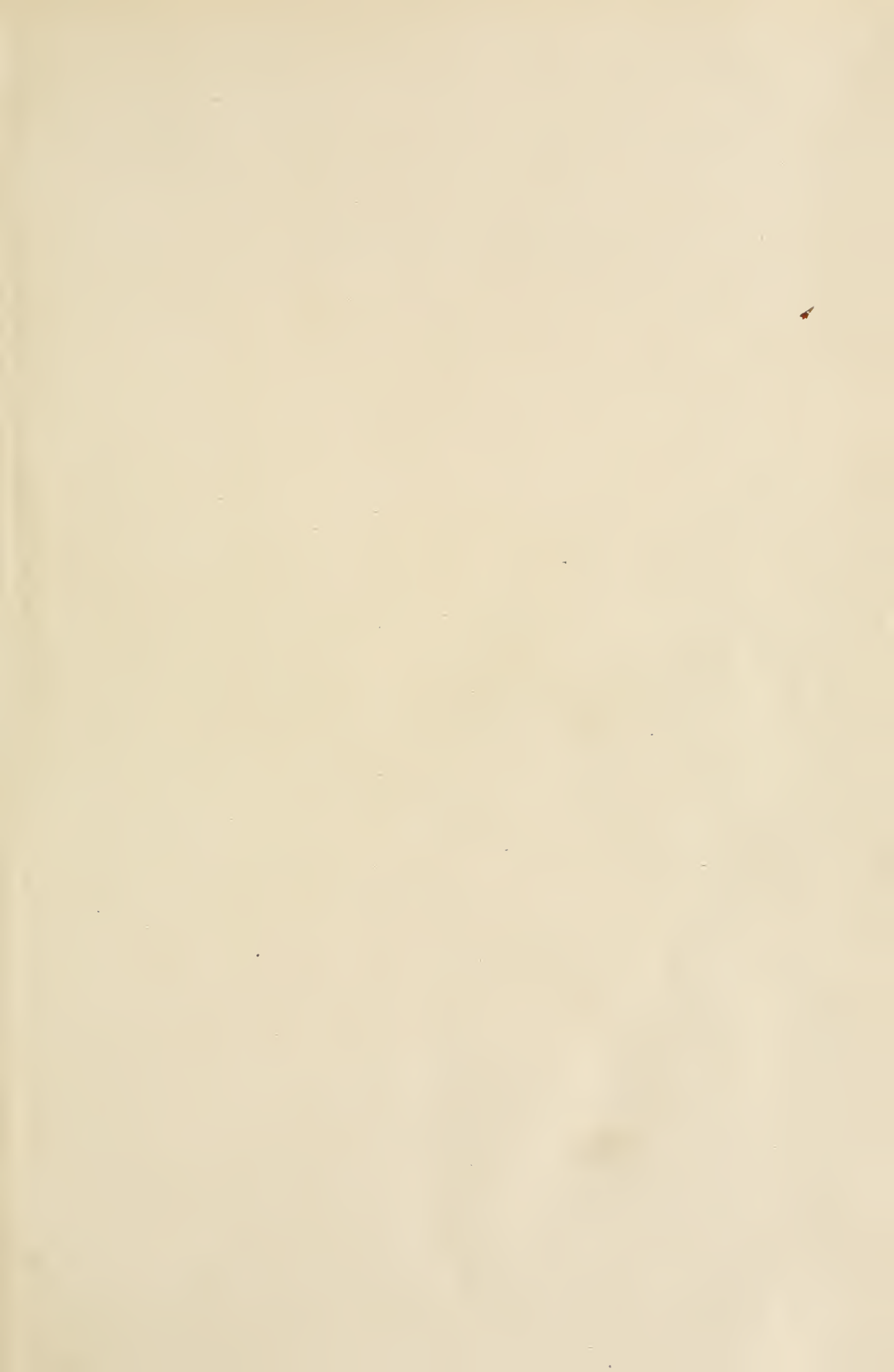

DEC 12 1918

Aquatic Life



Volume II, 1916 - 1917



W. A. POYSER
EDITOR

PUBLISHED BY
JOSEPH E. BAUSMAN
PHILADELPHIA

Copyrighted 1916 - 1917
By JOSEPH E. BAUSMAN
All Rights Reserved

INDEX TO VOLUME II.

- Albinism, 132.
 Alfaro amazonum, 124.
 Algae, Four Species of, 50.
 Ambassis lala, 3.
 Amblystoma: Food for, 100; opacum, 113; punctatum, 61.
 Amoeba, 51.
 Anacharis, 13, 83.
 Anolis carolinensis, 72.
 Aquarist Avoids, The, 18.
 Aquarium: "Aquarium," The Word, 65; Assortment of fishes for, 16; Bunsen burner, 14; Care and management, 81; Changing water, 28; Cleaning bottom, 80, 131, 144; Dip-nets, 52, 95; Dip-tube, 80, 131; Diseases, 86, 100; Evaporation, 28; Fishes at surface, 71; Food rings, 135; Food sieve, 95; Heating, 9, 14, 77; Heating by electricity, 77; Heat regulation, 11; Hints, 28; Hydra, 13, 62, 64; Illustrations of aquaria, 19, 22, 29, 59, 77, 81, 82, 105, 151; Light control, 65, 135; Location of, 28, 135; Mahogany aquarium, 105; Minute inhabitants of, 35, 50, 63, 91; Museum aquaria, 151; Notes, 60; Ornamentation, 30; Overstocking, 71; Plants, 7, 13, 23, 25, 30, 37, 59, 60, 61, 81, 88, 99, 142, 159; Pleasure of, 29; Scavengers, 86 (see also "Snails"); Sheep manure, 31; Soil, gravel, sand, 13; Stands or supports, 12; Swamp aquaria, 58; Thermostat, 11; Unwise management, 18; Vacuum cleaner, 131.
 Bass, Indian Golden, 3.
 Beetle, Life-history of, 126.
 Belonesox belizanus, 143.
 Betta: pugnax, 119; species, 117.
 Bitterling, The, 15.
 Boleosoma nigrum, 55.
 Butterfly Fish, 112.
 Carp: Culture of, 158; Mirror, 21.
 Catfish, Brazilian, 73.
 Chameleon, American, 72.
 Chanchito or Shoat, 57.
 Cichlasoma facetum, 57.
 Cobitis or Weatherfish, 86.
 Community Aquaria, 16.
 Conservatory Thermostat, 23.
 Corydoras, Breeding a, 73.
 Ctenops vittatus, 118.
 Dace, Black-nosed, 32.
 Danio: analipunctatus, 161; Giant, 125; malabaricus, 125; Spawning tank for, 162.
 Daphne (Daphnia): Collecting net for, 95; in Lake Mendota, 102; Propagating, 19, 93; Sieve, 4, 95.
 Darter, Johnny, 55.
 Diatoms, Notes on, 155.
 Diemyctylus: pyrrhogaster, 1; viridescens, 44, 45, 126.
 Earthworms: A Fish Food, 5.
 Enchytrae, 28, 43.
 Fish Culture, A History of, 145.
 Fishes and Reptiles in Winter, 21.
 Fishes: Brain of, 106; Hearing of, 13; Hybridizing, 66, 134; Inbreeding, 123; Lateral line, 112; Respiration of, 70; Scales of, 112; Transportation of, 14, 30.
 Foods, Fish: Amoeba, 51; Ant eggs, 136; Corethra, 118; Cyclops, 92, 117; Cypris, 92; Daphne (Daphnia), 19, 54, 91, 93, 117; Diatoms, 155; Dry prepared, 100; Earthworms, 5; Enchytrae, 28, 43; Grading of, 95; Infusoria, 90, 117; Microscopic, 35, 50, 90, 92, 117; Mosquito larvae, 144; Oyster, 58; Paramecium, 51; Rings, 135; Rotifers, 92; Sieve, 95; Shrimp, 56; White-worms, 28, 43.
 Frog: An Albino, 132; Florida Gopher, 153; Java Flying, 34; Leopard, 133; Peeper, 103.
 Fundulus and Notropis, Notes on, 67.
 Fundulus: chrysotus, 141; diaphanus, 68; Golden, 141; gularis, 47.
 Gambusia affinis holbrooki, 40, 99.
 Gambusia, Morphology of, 6.
 Gasteropelecus species, 107.
 Geophagus jurupari, 162.
 Goldfish: Bag-tail, 28; Black Telescope, 27, 115; Blue Calico Telescope, 123; Breeding and rearing, 87 (see also "Aquarium"); Calico Telescope Broadtail, 5, 65, 70, 87, 145; Common, 82; Conservatory for, 109; Daphnia, Daphne, 19, 54, 91 (see also "Foods"); Diseases, 86, 100; Egg congestion, 96; Excrement of, 13; Growth of, 40; Hydra, 13, 62, 64; Inbreeding, 123; Infusoria, 90; Jap Broadtail, 84; Lionhead, 31; Low-priced, 8; Moor Telescope, 27, 115; Opaque-scaled Telescope, 101; Queen Lil, 70; Roe-bound female, 96; Sex identification, 87, 93; Scurvy, 101; Shubunkin, 13,

INDEX

- 49; Spawning, 87; Spawning net, 95; Taubles' Pond, 39; Temperature, 96.
- Gourami: Dwarf, 118; Purring, 118.
- Guppy (*Lebistes*), 96.
- Haplochilus: *calliurus*, 48, 130; *cameronensis*, 129; *fasciolatus*, 130.
- Haplochromis *strigigena*, 120.
- Haplomi, Notes on Order, 137.
- Hatchery, Unity Commercial, 79.
- Heat Regulation, 11, 22.
- Heating the Aquarium, 9.
- Heros facetum*, 57.
- Hibernation of Fishes, 21.
- Hybridizing Fishes, 66, 134.
- Hydra (Polyp), 13, 62, 64.
- Hyla pickeringii*, 103.
- Isoetes, 7.
- Jordanelia floridae*, 121.
- Kitefish, The, 89.
- Labyrinthine Fishes, Breeding, 117.
- Lace Plant, Madagascar, 37.
- Leach, The, 52.
- Lebistes reticulatus*, 96.
- Macropodus: *opercularis*, 149; species, 117.
- Marsilia, 62.
- Minnow: Fiery-black, 102; Iron-colored, 78; Mud, 137; Steel-colored, 78.
- Mosquitoes, Life-history of, 144.
- Mouth-breeder, Cichlid, 120.
- Mud Minnows. With Notes on the Order Haplomi, 137. (Describes a new subspecies of *Umbra pygmaea*.)
- Mussels, Freshwater, 17, 149.
- Newt: Common, 45, 127; Japanese Red-bellied, 1.
- Nitella*: *flexilis*, 100; *gracilis*, 100, 112.
- Notropis and *Fundulus*, Notes on, 67.
- Notropis: *chalybaeus*, 78; *hudsonius amarus*, 68; *pyrrhomelas*, 102.
- Oosphromenus*: species, 117; *striatus*, 118.
- Ouvirandra fenestralis*, 37.
- Pantodon buchholzi*, 112.
- Panzerwel, 73.
- Paradise Fish, 60, 117, 149.
- Paramecium, 51.
- Plants, Aquarium, 7, 13, 23, 25, 30, 37, 59, 60, 61, 81, 88, 99, 142, 159.
- Polycentrus schomburgki*, 157.
- Pseudocorynopoma doriae*, 89.
- Pterophyllum scalare*, 163.
- Puffer Fish, 69.
- Pyrrhulina filamentosa*, 33.
- Quillwort in *Aquaria*, 7.
- Rana oesopus*, 153.
- Respiration of Fishes, 70; Physics of, 115.
- Rhodeus amarus*, 15.
- Riccia fluitans*, 117, 142.
- Sagittaria*: *natans*, 83; *sinensis*, 100; species, 13.
- Salamander: Food for, 100; Gray, 127, 128; Mythology of, 128; Notes on the, 127; Opaque, 113; Purple, 128.
- Schlammeisser, 86.
- Shark, The Nurse, 25.
- Snails: African, 148; *Ampullaria*, 88; Bubble-shell, 13; Copenhagen Red, 13, 148; Coral, 13, 148; Eared, 148; Four-horned, 88; Japanese, 13, 148; *Lymnaea auricularia*, 149; *Lymnaea stagnalis*, 149; Niagara, 148; *Paludina contecta*, 149; *Physa heterostropha*, 13; *Planorbis corneus rubra*, 148; *Planorbis trivolvis*, 148; Potomac, 148; Ramshorn, 148; Red, 13, 148; *Viviparus malleatus*, 148.
- Soy Lees, 28.
- Spring Peeper, 103.
- Sunfish, Black-banded, 85.
- Swordtails, Mexican, 97.
- Tadpoles, Value of, in *Aquaria*, 14.
- Thermostat, Aquarium, 11.
- Trichogaster*: *lalius*, 118; species, 117.
- Umbra*: *limi*, 138; *pygmaea bilineata*, 147; *umbra*, 139.
- Unio complanatus*, 17.
- Vallisneria*: Cells of, 26; Cultivation of, 159; *spiralis*, 25; Tortuous Form of, 159.
- Water Hyacinths a Pest, 2.
- Water, Surface layer of, 13.
- Weatherfish or Schlammeisser, 86.
- Worms, White, 28, 43.
- Xiphophorus* species, 97.

50,938

September, 1916

10¢ Copy

Aquatic Life



J.H. Goodby
1916

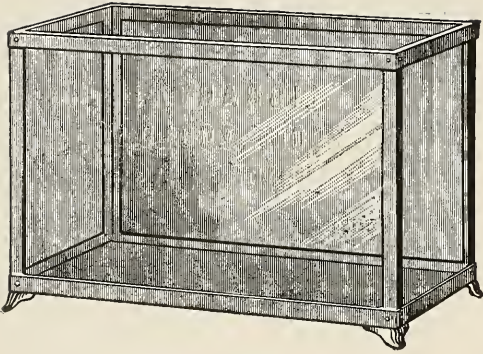

Jacob C. Cassel

915 Arch Street, Philadelphia, Pa

Manufacturer of

AQUARIUMS

Aquarium Ornaments

Floral Terra Cotta, Etc.

Goldfish

Fish Globes

Fish Food

and all aquarium requisites.

Send for Catalog.

Aquarium Specialty Co.

1873 WASHINGTON AVENUE

::

NEW YORK CITY

Special Offer

Acclimated Imported Stock of Large Size

Jordanella floridae Gambusia holbrooki

Mollienisia latipinna Fundulus chrysotus

Single Pair \$1.50

Lots of 5 Pair of Each at \$6.25

Lots of 10 Pair of Each at \$10.00

YOUNG LIONHEADS (Perfect Form) AT 40c EACH

YOUNG CALICO JAPS & TELESCOPES AT 25c EACH

Reduction in Quantities

We Buy for Cash, or Exchange Your Surplus

Stock in Any Quantity

Correspondence Solicited

No Catalogues Issued

JOS. TAUBLES, Manager

Please mention AQUATIC LIFE when writing advertisers.



The Red - Bellied Newt

DR. R. W. SHUFELDT



Red-bellied Newt

Diemyctylus pyrrhogaster

Photographed by the Author

During the latter part of March of this year (1916) Mr. Edward S. Schmid, the well-known pet fancier, of Washington, D. C., obtained from a Japanese dealer in San Francisco, a lot of over one hundred specimens of that most beautiful salamander of Japan, the Red-bellied Newt (*Diemyctylus pyrrhogaster*). This elegant form belongs in the same genus with our common little spotted water newt (*D. viridescens*), though, in my opinion, it is not very closely related to it—at least, each may be at the extreme limit of the generic confines of that group.

Mr. Schmid very generously loaned me half a dozen specimens from this fine collection, and these I picked out for the great differences to be seen in the color distribution on their under parts. Five

of them formed the subject for a colored wall chart which I prepared, giving the animals a size of some six times that of life (linear). Employing this chart as a means of demonstration, with the aid of the living specimens in a small fish globe, I presented a brief account of these very interesting batrachians at the meeting of the Biological Society of Washington, which was held on the 8th of April, 1916. Subsequently I copied my chart with the camera, reducing the five figures to the natural size of the living animals, and these I colored as in life. This illustration is here reproduced to supplement the short description given below.

Superiorly, the skin of this batrachian is rather rough, due to the presence of a fine, warty growth upon it. When seen

directly from above, this dark or blackish-brown skin is in no way relieved by any brighter color, and the observer would never suspect the brilliant orange vermilion of the markings of the under parts. No two specimens have these two highly-tinted patterns alike; but by studying the series it will be observed that in some individuals the colored area is nearly entire, as shown in Figs. 1 and 2, more or less of the inferior border of the tail being always red. Still, where this area is nearly entire, either one or both of its outer margins are more or less broken and jagged, with a few off-lying islets of red spots.

From this stage the pattern appears to take on two or three different styles. It may tend to become broadly zigzag between the throat and the vent, as in Fig. 3; or it may form a median line with crooked lateral branches and a few scattered spots, as in Fig. 5; finally, it may break up into irregularly formed islands and spots of color, as exhibited in Fig. 4. Rarely are the color spots to be found on the under side of the limbs. Again, the color area frequently seems to persist about the genital fissure or the vent, as the case may be, and in many specimens the chin area is unbroken. I am strongly inclined to believe that these color patterns are quite independent of the sex of the individual, and possibly of age.

This seems to be a hardy species, and is certainly a very beautiful creature in an aquarium. They are very fond of small frog tadpoles and angling worms; and as some of the females appear to be heavy with spawn, I am in hopes that later on I may have the opportunity to try to rear the young from eggs. They seem to like pretty deep water, and have no apparent inclination to come up on the mossy bank or flat stones that rise out of it. This newt is probably quite as

harmless as any other species of *Diemyctylus*—indeed, I must believe they destroy the larvæ of many undesirable aquatic insects, perhaps mosquito larvæ, in which case it would be a beautiful addition to introduce into our ponds, in that it might, in time, become a part of the aquatic fauna of the country, in such localities as it would be likely to thrive. It certainly makes a very interesting and strikingly handsome addition to the aquarium.

Water Hyacinths a Pest

Experiments on water hyacinth have been carried on in French Indo-China for the purpose of turning to some profit the growth which encumbers the lower Mekong and other waters of Cochin China and Cambodia to such a degree that it has become a positive menace to navigation. The fibre produced by this plant, according to the "London Engineer," has been used in the manufacture of rope, twine, matting, paddy sacks, boxes and chairs, cradles and other articles of furniture. It has been mixed with silk to form a somewhat stiff but durable cloth. Water hyacinth has now entered the commercial field as a rival of rattan, rather than jute. It is stated that since April, 1911, the plant has been dried, compressed into briquettes, and used as fuel at Khartum and other points on the Upper Nile. These briquettes can be put on the market at \$5.75 per ton, and it is said that tests made on a steamer on the White Nile have demonstrated that their efficiency as a fuel equals that of the same amount of the best coal.

Torn—"Why is the frog the most economical animal?"

Dorn—"Because, after casting off its skin, it rolls it into a neat ball and eats it."



The Indian Golden Bass

WALTER LANNOY BRIND, F. Z. S.

From the "Land of Mysteries," India, that densely populated country inhabited by more than forty million people, and boasting of as many as forty different languages, comes to us one of the most spiritual and elfin-like of the fishes that grace and lend an air of mystery to our aquaria—the tiny Golden Bass, *Ambassis lala*. This little bass, for such it unmistakably is, averages little over an inch in length, with a depth of body of a third as much, and a thickness at the thickest part of the thorax of—nothing. Well, if not "nothing," then so close to it that a sheet of paper seems thicker and more visible. Herein lies the mystery of this dainty little fellow. He never, if he can help it, permits a broadside view of his glittering though transparent body, for he is ever heading straight at you, or else in the opposite direction, so that it is almost necessary for two people to approach the aquarium from opposite sides in order to steal a glimpse of him as he (or she) rushes to cover among the leaves of the plants which afford shelter and surroundings most congenial to him. In his home waters there is always an admixture of sea salt, such as is found in the haunts of our own *Mollienisia latipinna*. *Ambassis lala* will live contentedly in quite fresh water, though I always add sea salt to the proportion of a tablespoonful to five gallons of water, using old aquarium water in preference.

To those desirous of breeding this dainty fish I would advise a large aquarium—two or three feet long by eighteen inches to two feet wide; water

to a depth of six to eight inches; clean silver sand on the bottom, planted with thickets of *Vallisneria* in the corners and along three sides, open in front and centre. A bunch of *Nitella* in at least one corner will afford shelter for the female should an argument arise. A temperature of about 75 degrees Fahrenheit, for breeding, and 65 to 72 degrees at other



Ambassis lala

times, suits it to perfection. The eggs are deposited among the plants wherever they are dense and free from waste matter and excreta. They are tiny, clear as crystal, and are deposited in lots of five or six at a time to a total of thirty to fifty. The parent fish in the act of laying the eggs swim side by side, the function being performed with so swift a movement through the plants that it can hardly be witnessed. The period of incubation is from ten to fifteen hours. After hatching, the fry cling to the glass and plants for three or four days.

The aquarium should be placed less than a yard distant from an east window where there is abundant morning sun-

shine, the narrow end should be nearest the light. As with other species, the first food of the little fish is Infusoria, later they prefer tiny *Daphnia* and *Cyclops*. The greatest care must be exercised to strain the *Daphnia* and *Cyclops* through a very fine brass wire screen or cloth, so that no large ones pass through. The young are very voracious as they grow up and often choke themselves on large mouthfuls of live food. Prepared

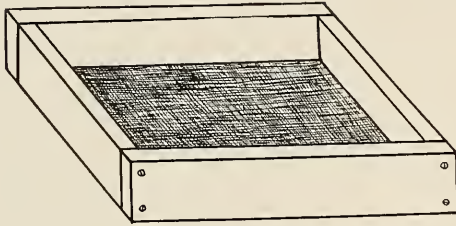

Daphne Sieve

dry foods, and indeed anything but live food, is out of the question for *Ambassis lala*. There is no reason why any one who is fortunate enough to possess this most desirable fish should not do as I do throughout the winter when *Daphnia* is scarce, namely, keep a constant supply in mason jars set in an east window, with dirt on the bottom of each, and water plants thrown in at random. As the sunlight encourages the growth of algæ on the inside of the jars the *Daphnia* thrive. Of course, only a few, say the equivalent of a large pea in bulk, can be maintained in each jar—the cooler the room the more you can keep, within certain limits. With twenty-four jars a good supply can be maintained for such fish as absolutely require them.

No more beautiful sight has ever greeted my eyes than a series of four successive broods of *Ambassis lala* which I saw at the residence of Mr. Carl Schmidt, of Freidrichshagen, near Berlin, Germany. This gentleman devoted himself at that time, 1910, exclusively to

breeding such rare and interesting fishes with which other fanciers had not succeeded, and his efforts were crowned with great success. The young *Ambassis* swam, or rather sailed, around their spacious homes like fleets of cutter yachts, all in the same direction, and all with dorsal and anal fins erect and tails spread wide.

The male *Ambassis* is like a thin slip of amber glass with golden gleams as the light strikes it at an angle. The dorsal, anal and tail fins are marked with Indian red, and have light blue edges. There are a few indistinct vertical, broken black bars on the sides. The female is more greenish, and clear, glassy and transparent, the red of the male being absent. During the summer the ovaries are visible through the abdominal walls. The Golden Bass is a shy little fish, and great care must be exercised not to frighten it.

Don't Be Hasty

Though time onward speedily flies, and summer's sun is setting, not for some time will it be wise to shake ye 'skeeter netting.

An enthusiastic fisherman was telling some friends about a proposed fishing trip to a lake in Colorado he had in contemplation.

"Are there any trout out there?" asked one friend.

"Thousands of 'em."

"Will they bite easily?"

"Will they? Why, they're absolutely vicious. A man has to hide behind a tree to bait a hook."—*Country Gentleman*.

"We behold all round about us one vast union, in which no man can labor for himself, without laboring at the same time for all others."—*Hyperion*.

The Earthworm: A Fish Food

JOHN R. BASCOTT

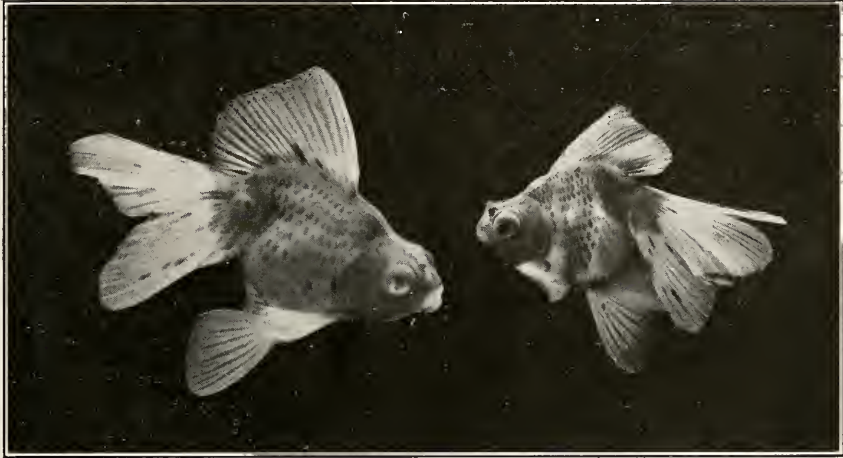

Owned by John McGinnis

Owned by W. H. Heimbach

YOUNG CALICO TELESCOPE BROAD-TAIL GOLDFISH

The type you are proud to possess at the close of the outdoor season

If one asked "What is an earthworm?" the probable answer would be "food for fishes." True, and fine food, but there the question would likely rest. Its skin is soft and naked, and protected with a coating of slime. The body consists of from one hundred to two hundred rings, each provided with minute bristles. It is these bristles that enable the worm to so successfully resist being pulled from its hole, even though it be rent apart. The muscular system is well developed, and the animals can crawl backward and forward. The internal organs are rather simple, though to describe them thoroughly would require many pages. In brief, it has a pharynx, which is pushed forward when it eats. This conducts to the œsophagus, which is enlarged into a crop in front of the gizzard. The latter organ opens into the intestine, which

runs in a straight line to the vent. Tiny grains of sand are found in the gizzard and intestine, and probably serve to grind the food. Respiration is carried on through the whole surface of the body. Eyes and ears are not present, but the animal is sensitive to light and sound. Each individual unites the two sexes in its body, but two worms pair together. The eggs are contained in a sort of cocoon formed of mucus, which hardens when exposed to the air.

The earthworm feeds on vegetable substances contained in the soil, so that it is constantly swallowing earth to obtain nutriment. It plays a most important part in the economy of Nature, as, by breaking up and mixing the soil and by dragging leaves into its burrow, it has tilled and manured the earth for ages. They are found throughout the world. Though

few in species, they make up in numbers. It has been estimated that they average about one hundred thousand to the acre.

The earthworm forms an excellent and easily obtained food for many aquarium fishes. It is customary to select small, tender ones—not large “night crawlers”—and to cut each into small pieces suitable in size to the particular fishes to be fed. When tiny particles are desired for fry, place a tablespoonful of coarse sand in a round-bottom china bowl, add a few worms killed by scalding, then proceed to grind with a smooth, water-worn pebble the size of a hen’s egg, just as a chemist would use a mortar and pestle; add water, stir rapidly for a moment, pause to allow sand to settle, then pour off into another vessel. The tiny particles of worm will be held in suspension in the water longer than the heavier sand. By thus decanting several times if necessary, the ground worm will be separated from the sand and may then be fed.

For a winter supply of worms, secure a wooden box from the grocer, or several if a large supply is desired. Be certain that the box is securely nailed. Put in a two-inch layer of garden soil and leaf mould, and over it distribute a good layer of worms. Add two more layers of earth and worms, with an inch layer of soil on top. Cover with three boards an inch thick, leaving an inch space all around, with a brick on each board. Place the box in a moderately cool cellar, and sprinkle occasionally to keep moist. Every sixty days mash a cold boiled potato and mix with the top layer of soil. When worms are desired, lift off the boards and they will be found on the surface. Do not disturb the soil any more than is necessary.

When you can’t remove an obstacle, plow around it.—*Lincoln*.

On Morphology of *Gambusia*

W. S. HILPERT

One of the most interesting studies carried out at the Laboratory of the Bureau of Fisheries, at Beaufort, N. C., is that reported by Dr. Albert Kunz, of the University of Iowa, in “Science.”

Dr. Kunz’s studies were devoted to the morphology of the reproductive organs of *Gambusia affinis*, which abounds in the vicinity of Beaufort, in all the fresh water streams entering the harbor. His efforts were especially directed to the structure of the apparatus controlling the modified anal fin in the male *Gambusia*. “This fin,” the report tells us, “functions as an intromittent organ and is controlled by a powerful muscle, which has its origin on a bony process projecting ventrally from the fourth to the last abdominal vertebræ, and the modified anal spines of the proximal end of the anal fin rays. The third, fourth and fifth rays of the fin are enlarged, greatly elongated and variously curved, bearing short spines on their distal portions. The interhemal which articulates with the third ray is enlarged and sufficiently elongated to articulate with the two anterior processes, on which the muscle controlling the anal fin has its origin. The fifth ray may be drawn forward at one side of the fourth and brought into proximity with the third. In this manner a groove or tube is formed, through which the milt is transferred from the male to the female.”

The study of Nature is an intercourse with the highest mind. You should never trifle with Nature. At the lowest her works are the works of the highest powers, the highest something in whatever way we may look at it.—*Louis Agassiz*.

The Quillwort in Aquaria

AQUA - PET

Even to botanists, the ISOETACEAE, regardless of its interesting characteristics, is a comparatively little known group of plants, comprising about fifty species. The generic name *Isoetes* is said to be derived from two Greek words meaning "equal" and "year," and was applied because of the perennial character of the leaves. While the purpose of this article, primarily, to direct attention to their interest as aquarium plants, inasmuch as they are usually ignored or given scant attention in works on the aquarium, it may not be amiss to give a brief description which should aid in identification.

The systematic botanist regards this group as a difficult one. Students of plant life are not by any means agreed as to what constitutes a distinct species of this genus, nor its relationship to other classes of plants. It belongs in that division of the vegetable kingdom called PTERIDOPHYTES, which includes the ferns and some other spore-bearing or flowerless plants called the fern allies. In the scale of plant development the pteridophytes are above the mosses and below flowering plants. Some botanists consider the Quillwort to be related to the Moonwort and Adders-tongue ferns, around which so much superstition clustered in ancient times, while others aver that its structure indicates a connection with the pines and related plants which are the more primitive forms of flowering plants.

The quillwort is essentially an upright or spreading rosette of hollow, cylindrical, pointed leaves of a grasslike or rush-like aspect. The leaves vary in length in the various species from a few inches to two feet, and in number from

ten to two hundred, or even more, springing from a flat bi-lobed or tri-lobed tuber-like rootstock. The new leaves are produced from the centre of the rosette. The plant reproduces from spores, which are born in a hollowed-out portion of the base of the outer leaves. The quillwort

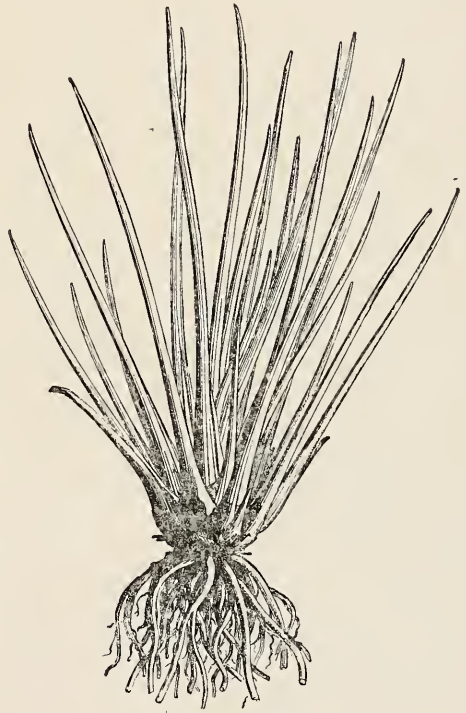

The Quillwort

is heterosporous, that is, bears spores of the two sexes on the same plant, but in different leaves. The female spores are about one-fourth the size of a pinhead and few in number, while the male spores are about one-thousandth of an inch in diameter and very numerous. The spores have an outer coating of silicon, that of the male spore being beautifully sculptured. A microscope is, of course, re-

quired to see the marking. Much stress is laid on this characteristic in distinguishing the various species.

The quill wort occurs growing in sand, mud and gravel on the bottoms and banks of lakes and streams. A great many species are always submerged, while others are only partially so, or are terrestrial. It is rather rare and local, but is apt to be abundant when found. Being inconspicuous, it is probably often overlooked.

While the adaptability of the quillwort is not as broad as some other aquarium plants, it is entitled to consideration on account of its interesting characteristics and position in the vegetable world. In the aquarium it increases in size and luxuriance, but can't be propagated, except possibly by dividing the rootstock. Snails are very fond of it, hence if one would have quillwort, out must they go. It is remarkably tenacious of life. Throw a plant into a tank with snails, where it will float at the surface, and it will send forth leaf after leaf in spite of their onslaughts until finally it is overcome and nothing remains but the rootstock. Regardless of this, it should be in every tank that is without snails, and those fishes that will attack plants.

"Say, bub," remarked a would-be fisherman, "are there any fish in this stream?"

"Yes."

"Will they bite?"

"None of them ever bit me, mister; but you don't need to go into the water to fish if you don't like."

We frequently read about cats mothering chickens, but up to the present time no correspondent has had the nerve to tell us that a goldfish is trying to bring up a brood of parrots.

Low Priced Goldfish

Goldfish enthusiasts remote from the centres of the greatest activity in breeding the fancy varieties, are apt to be discouraged by the rumors of the prices commanded by fine specimens. It is not the purpose of this note to enter into a discussion of how much can be spent, but how little will suffice to stock an attractive home aquarium. The novice should neither be attracted nor repelled by the fascination of value. The maximum prices for very fine specimens are usually paid by experienced breeders who desire to improve their stud, or to win in competition. It seems that the more perfect a fish the harder it will be to keep in condition. This is not a matter of much moment to the experienced aquarist, but to the novice the loss of such a specimen will be a severe shock, and very discouraging.

During the late summer and autumn months it is possible to buy very attractive fish at little prices—twenty-five cents up. These will not be show fish, but will make handsome aquarium pets. If an occasional one dies the loss will not be great. Given the proper food and a fair-sized tank, they will grow in beauty and ultimately breed just like their more perfect relatives. Much will be learned from them, and the desire created for better ones. And not the least, these fishes will increase in value. Pet shops should encourage the sale of fancy varieties in preference to the common, if only for this reason. The common kind, costing a dime, increases little in value, in fact, pond fish twelve inches long sell for but a dollar.

I am the wiser in respect to all knowledge, and the better qualified for all fortunes for knowing that there is a minnow in that brook.—*Thoreau*.

HEATING THE AQUARIUM

EDGAR TALLMADGE

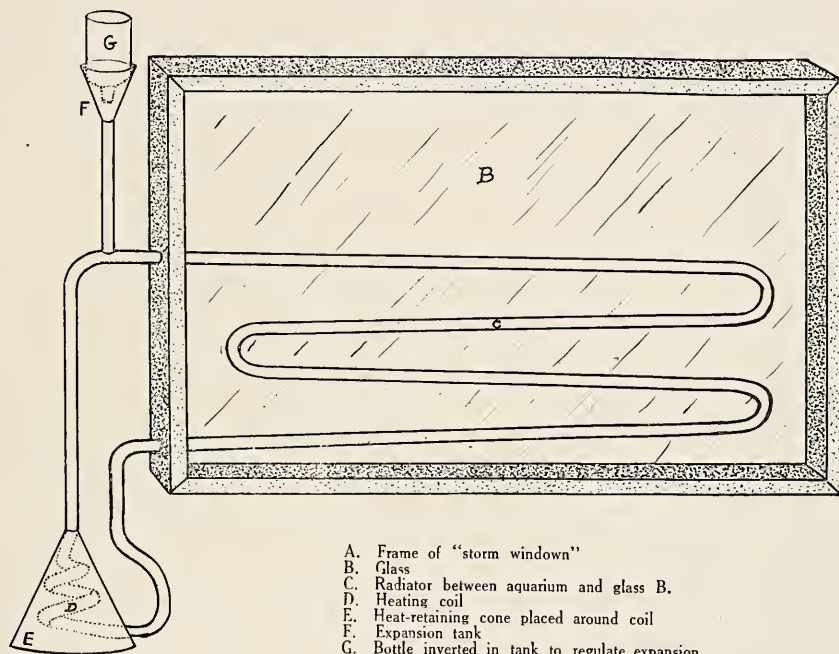

- A. Frame of "storm window"
- B. Glass
- C. Radiator between aquarium and glass B.
- D. Heating coil
- E. Heat-retaining cone placed around coil
- F. Expansion tank
- G. Bottle inverted in tank to regulate expansion

The question of heating aquaria confronted me at the commencement of winter, and no doubt other lovers of tropical fishes have been perplexed by the same problem. To those old at the game, or more fortunate in having a room heated to and kept at a given temperature, this will not make interesting reading, but to those not so fortunate my experiments may be of value and possibly lead to an even better method.

When I recalled my previous experiences in heating the room in which I have my fishes, I felt no little concern for them. However, as it was the only room in the house affording the proper light, it was up to me to furnish the neces-

sary heat for my tenants. I inquired of the older members of the society and had shown and explained to me all the known and tried systems of tank heating. I selected one that seemed best suited to my conditions. It was the hot water system that enters at the top of the tank and drops to the bottom, then returns over the top again to drop to the heating coil. I constructed one and tried it out before putting it into the tank. It worked so beautifully that I began to figure how to keep the fishes from burning themselves as I pictured them gathered around to keep warm. Alas! All my hopes and schemes were shattered, for as soon as I placed the radiator in the tank, and it

Aquatic Life

A monthly magazine devoted to the study, care and breeding of native, tropical, gold and fancy fishes, other animals and plants in the household aquarium.

W. A. POYSER Editor
 JOSEPH E. BAUSMAN Publisher
 542 E. Girard Avenue, Philadelphia

Entered as second-class matter September 2d, 1915, at the Postoffice, Philadelphia, Pa., under Act of March 3d, 1879

Yearly Subscription \$1.00
 Foreign Subscriptions 1.35
 Single Copy 10 cents

Payments may be made by express money order, draft, postoffice order or registered letter. Foreign remittances should be by international money order.

Advertising rates made known on application. Aquatic Life is the only magazine in America devoted exclusively to aquatic life, and its value as an advertising medium in this field of nature study is unequalled.

Patrons will confer a favor by sending us the names of responsible Pet Stock Stores who do not keep Aquatic Life on sale.

Copyright, 1916, by Joseph E. Bausman.

VOL. 2 SEPTEMBER, 1916 No 1

sank below the surface of the water, it became chilled, circulation stopped, and I saw at once that it would not work. Out it came, and was relegated to the junk heap.

I went to a friend with my problem, to Rev. Paul W. Roth, and, much as I would like to take it myself, I must give him credit for the "storm window" heater, contenting myself with the credit of constructing it with a slight improvement over his idea. It has at least one advantage over other hot water systems in that no metal—pipe or anything else—is placed in the aquarium. The heater consists of what we will term a "storm window," enclosing a hot water radiator, and placed on the outside of the tank and out of sight from the room. The apparatus consists of a frame or shallow box the size of the tank, and one and

one-half inches deep, with a light of glass set in it. It in no way obstructs the light, and, if it did no more, it would keep a lot of cold air away from the window side of the aquarium. The frame is placed against that of the tank, and in the resulting space of one and one-half inches between the two pieces of glass is placed the hot water radiator, for which any suitable small tubing may be used. I chose small lead pipe having an internal diameter of one-quarter inch, such as is used in the construction of pipe organs. The portion that is outside of the frame is made of copper tubing, a part of which is bent to form the heating coil. Around this coil is placed a heat-retaining cone of tin. After the system has been filled with water a bottle of water is inverted and placed in the brass expansion funnel. By this means the system is supplied constantly, evaporation is slight, and constant watching of the water level is obviated. The heater is held close to the aquarium by means of clamps made from strips of sheet metal.

I have intimated that the room in which I keep my fishes is not easily heated in cold weather, but with the heater I have had no difficulty in maintaining a temperature of 72 to 74 degrees Fahrenheit, in the tank with a temperature at times in the room of about 60 degrees, and have been unable to detect a variation of the water temperature, showing that the radiation through the tank is very good. The aquarium has a capacity of about twenty-five gallons, measuring thirty by fourteen by fourteen inches.

Just a word in regard to the source of heat and its application. I have no doubt but that good results could be secured by using a small oil lamp, but I find that a Welsbach burner from an upright light, with the mantle removed but retaining the screen cap, will do all that

is required. It has a regulator, so that the size of the flame can be adjusted to the requirements. The flame is placed about even with the heating coil. In ordinary winter weather I use a flame one-fourth inch high; if very cold a half-inch or even more. I keep the tank covered with a piece of glass, which conserves the heat.

In making the necessary joints of the radiator I used, as a flux, zinc cut up in dilute hydrochloric acid. While I did not do so, it will be well to fill the pipes with dry sand before making the various bends. Otherwise, unless great care is exercised, the pipe may buckle at the curves and cause impeded circulation. To use sand, fill the length and then close each end with a pair of flat-nosed pliers, or hammer shut; bend slowly in a wide circle, then snip off the ends and pour out the sand. Be sure the pipe is clear before proceeding with the soldering—blow through it.

pipe is cut at an angle, so that the rising mercury cuts off the gas gradually and not suddenly, as it would if the pipe was cut square. Of course, the tiny hole in the tube just below the cork acts as a by-pass and permits the passage of sufficient gas to keep the burner alive.

Mr. Dorsey has used this regulator in an aquarium placed before a window dur-

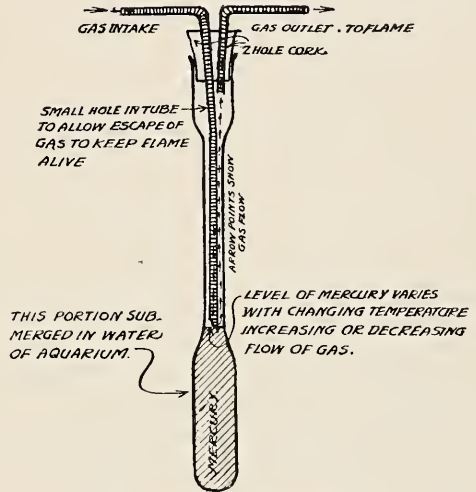

Aquarium Thermostat

Heat Regulation

When gas is used to heat an aquarium the regulation of the heat becomes a simple matter if a thermostat is used. It may be secured from any dealer in laboratory equipment, and can readily be adjusted to the needs of the tropical aquarium. Stock patterns usually provide for a greater supply of gas than is needed, but can be changed as desired. The form illustrated herewith was described several years ago by Mr. L. M. Dorsey. The regulator is submerged in a corner of the aquarium, and the gas conducted to it from a fixture in the room, then from the outlet to the burner used. A few experiments will serve to determine the proper height for the mercury and the position of the gas intake pipe. It will be noted that the intake

ing the winter months, when the room temperature frequently dropped thirty degrees, yet the aquarium thermometer constantly registered the 70 degrees the thermostat was set to maintain.

Jiggs—"I lent that geologist \$5, and he said he'd repay it in a very short time!"

Briggs—"He was doubtless speaking stratariferously! From pterodactyls to flying machines is a very short time, to a geologist!"

Agassiz taught his pupils to kill fish by a blow on the back of the head as soon as they were caught, that they might not suffer before dying.

What if the good things people intend to do tomorrow were only done today?

NOTES & NEWS

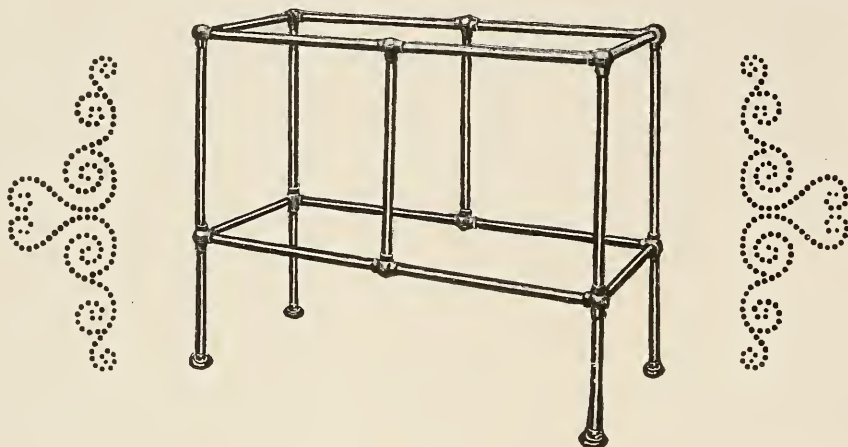

AQUARIUM STAND OF IRON PIPE

COURTESY OF JACOB C. CASSEL

It is not difficult to find a suitable support for a small aquarium, any small table of proper size will do, but with large sizes, the great weight requires a stand at once strong and durable. One of wood, while desirable because of its adaptability to various finishes, is apt to be, by reason of stout construction, cumbersome in appearance. The stand of iron pipe possesses every requirement except that of finish to conform to ordinary home furnishing, though, of course, it will be painted or enameled. If the aquarium frame is brass, a very handsome stand can be made of polished and lacquered brass pipe. One-half inch pipe will be sufficient for a stand for a twenty-gallon tank; three-quarter inch for fifty gallons.

The Philadelphia Goldfish Fanciers' Society will hold the first autumn meet-

ing in Saull's Hall, 802 Girard avenue, on September 20th. Annual auction of fishes and general discussion of the outlines of the work for the winter.—*Fred Richardson, Secretary.*

Otto Ruess, of Chicago, has a lot of young *Polyacanthus*, which he has named as follows: Polymurial, Pollyanna, Polypheumus, Political, Napoli, Appolinaris, etc. He has exhausted the dictionary under "Pol," and still has several hundreds of nameless babies on hand.—*Rev. Paul W. Roth.*

Mayor Preston, of Baltimore, has expressed a desire to have a public aquarium located in Fort McHenry Park. The fort, it will be remembered, figured in the battle which inspired Francis Scott Key to write "The Star Spangled Ban-

ner." Comments by the president of the Park Board, Mr. George Weems Williams, and prominent aquarists of the city, indicate that the project is not likely to be dropped. The movement is a further indication of the growing recognition of the value of an aquarium as an educational factor.

Potatoes Ala Daphne

Braunfoxit is a little wooded isle in the Housatonic River, Connecticut, a region rich in Indian lore. There the Reverend Arthur Boxer Creighton maintains his summer camp, and with him recently, as guests, were Mr. and Mrs. G. Frederick Wood and Mrs. W. A. Poyser. They discovered that the river water used for camp purposes was alive with Daphne. This luscious crustacean, beloved of our aquarium fishes, seemed to impart flavor to the camp cookery and zest to the appetite—perhaps it was the influence of the forest primeval. Like loyal fish lovers no attempt was made to strain the water. With the constantly increasing cost of high living, why not Daphne salad instead of lobster?

Where is the organ of hearing in fish located?—E. J. E. Each scale of the lateral lines of a fish is perforated by a tube leading to a duct connected with a sac in the head, their function being the secretion of mucus, which covers the body to lessen the friction of scales and water, and make it impervious. This mucilaginous system is also provided with nerves and is the seat of a peculiar sense which corresponds to the organs of touch and hearing.—From "Goldfish Breeds," by H. T. Wolf.

The Bubble-shell Snail is *Physa heterostropha*, a common native species of ponds and slow streams.

The name polyp (Greek *polypous*, many-footed) was originally given to the octopus in allusion to its many foot-like tentacles, and thence extended to the fresh water *Hydra*.

The extremely thin surface layer of water in contact with the air acquires physical properties comparable to those of an extremely fine membrane.

Goldfish fanciers who have bred the shunkunkin have found that a very few equal the parents in coloration. The majority of the young are plain colored, some are scaled, and a few of both will have double tails.

Large Jap and red snails should be watched closely and removed from the tank when they die, otherwise serious pollution of the water may result.

Aquarists are divided on the use of soil for aquarium plants. *Sagittaria* and *Anacharis* seem to grow just as well in sand or gravel. Under these conditions it is said that the roots serve mainly to anchor the plants and consume the humus, the leaves assuming a more attractive bright green color.

The excrement of a goldfish, when the fish is in good condition, usually appends for some time as a long worm-like thread. Its texture and freedom from mucous and gas bubbles rather than color indicates health. The color will depend upon the food, few other than daphne cause black-brown excreta.

Some men's religion is all located in their Sunday suit of clothes, and hung up in the closet during the week.

Tadpoles are very interesting "critters" in the aquarium, but have an unfortunate habit of stirring up the humus. If you would have them be clean, remove any accumulation of sediment at frequent intervals. In general, their value in an aquarium has been greatly over-estimated.

Don't look for flaws as you go through life, and even if you find them, be wise and kind and somewhat blind, and look for the virtues behind them.

For the transportation of the smaller tropical fishes, and particularly youngsters, a glass coal oil can holding a gallon, and protected by a jacket of tin or woven wire can be used to an advantage. In such a container a little Daphne can be placed to keep up the strength of the fishes.

"The utility of the study in natural history will be recognized by any one possessing even rudimentary ideas of the science."—*Milne-Edwards*.

The eggs of the smelt are so minute that about 500,000 are required to fill a quart measure.

For aquarium heating a very satisfactory small bunsen burner can be obtained from dealers in dental supplies.

Among the bereavements suffered by the Zoo last year was the death of a crocodile from tuberculosis. The report states that this is the first recorded of its kind. Reliable statistics of mortality from pulmonary diseases among crocodiles must be difficult to obtain; but it is highly probable that the disease is unknown on the banks of the Niger and Nile. The majority of the deaths among

the animals at Regent's Park are either from the maladies of civilized life or from over-eating. Medicine is useless where wild animals are concerned, and the only possible treatment in illness is careful dieting.—*London Chronicle*.

There is only one way by which we can reach our desired goal, and that is to get up and go.

Received by a land syndicate:

Sir: Your letter says if I don't pay the June installment on that 10 acres of Florida land you will start the machinery of the law moving in my direction. Well, I'm not going to pay it, or the July, or the August, nor any of the rest. I've quit, so start your machinery of the law, and I'll put a monkey-wrench into it that'll knock out more cogs than Mr. Blackstone could replace working nights and Sundays for the next three years.

Say, when that slick-tongued salesman of yours sold me those ten acres for \$50 down and \$10 a month as long as I live, he had the Indian sign on me, with his "back to the land" and "be your own boss" stuff. I used to sit out on the porch after supper smoking my pipe and dreaming about that Southern home, the bungalow among the palm trees, the evening breeze laden with perfume of orange blossoms, my orange blossoms. And now a friend of mine who went to Florida on other business sends me back a kodak picture of my farm that shows a fellow sitting in the middle of it, in a boat, fishing. It would be a grand place for a fishing lodge if there was a chunk of ground big enough to build a shack on, sticking out of the water anywhere. Did you think I could live in water just because I'm a *sucker*, or does a diving suit go with that ten acres? I didn't get mine.

Slowly the morning had passed into afternoon; then the afternoon had also evaporated; and now, as the poet said, "the shades of night were falling fast." But still the angler went on angling.

"Caught any fish, guv'nor?" asked a cheery and cheeky lad, as he paused beside the weary wielder of the rod.

The latter deigned no answer.

"Any luck, sir?" asked the boy persistently, as he loitered near.

"Go away!" snorted the fisherman angrily.

"No offense, sir," replied the lad, as he sauntered on. "I only wanted to say as my father kept the best fish shop in the village—down the second turning or the right from the church."

Gets rather cold at times in Minneapolis, but you can't cool the ardor of a fish fancier. When Mr. Peri-Cook builds a city at the North Pole, the first local organization will be an aquarium society.

John Pigg, of St. Louis, is about to be matched against the champion pancake eater of the country, and perhaps you will notice that there is a reason why we are willing to put all our money on John.

SAMUEL GRAFF

Breeder of Broad-tail Calico Telescopes

\$2.00 up

5013 Hawthorne Street, Frankford
Philadelphia



FOOD FOR THOUGHT AND FOOD FOR FISH

Why are some of the most successful breeders using YOGI since it was put on the Market and still using it to day. The above is food for thought if you want food for fish its YOGI. Sample 12c

Robert J. Schaeffer

1818 Frankford Avenue, Philadelphia

DRIED SHRIMP—Whole and Ground
Chameleons, Southern Fish (Mollienisia Etc.)

Send for Prices

W. C. FOCKELMANN, 749 Baronne Street
New Orleans, La.

Please mention AQUATIC LIFE when writing advertisers.

The Nature Study Review

OFFICIAL JOURNAL
AMERICAN NATURE-STUDY
SOCIETY

The numbers for the coming school year will be filled with special articles from practical teachers dealing with actual works, methods and suggestions for school gardening, elementary agriculture and nature-study.

DO NOT MISS ANY OF THEM

\$1.00 per year.

15c per copy.

SUBSCRIBE NOW

Add for Canadian Postage, 10c. Foreign
Postage, 20c. With Aquatic Life One
Year, \$1.50.

Address All Orders to

The Nature Study Review

ITHACA, N. Y.

Announcement!

Rare Tropical Fishes at Popular Prices

Trichogaster facetus $\frac{3}{4}$ grown . . . 35c each
Trichogaster lalius $\frac{3}{4}$ grown . . . 60c each

EXTRA LARGE SPECIMENS OF

Poeciliopsis peteri (new) . . . \$2.50 pair
Alfaro cultratum . . . \$2.00 pair
Gambusia holbrooki (pond-grown) \$2.00 pair

Aquarium Specialty Co.

1873 Washington Ave., New York City

Aquariums of Artistic Designs

*Strongly Built, Suitable for the Home,
Conservatory, College or Store*

Also all aquarium supplies. We make any size aquarium to order, slate or iron-bottom. Write your wants. Dealers with card write for lowest wholesale prices on globes, food and plants.

WE HAVE FOR SALE

Used little wonder pump, 25 gallon tank, gauge, and regulation valve. Price \$15.00

Address PIONEER AQUARIUM CO.
Racine, Wisconsin

AQUARIUM STOCK CO.

150 Chambers Street, New York City
Aquarium Specialists

Goldfish, Foods, Plants, Snails, Etc.

Combination Natural Fish Food, - Sample Can 10c
Imported Shrimp Fish Food, - - - Sample Can 15c
Imported Wafer Fish Food, - Large Sample Box 10c

Special Prices on Quantity Lots Cash With Order

Sole Agents: for Floyd's Unexcelled Bird Food for
Birds to Restore Their Song - - - Sample Bottle 25c

ORDERS AMOUNTING \$2 DELIVERED POSTPAID

Mail Orders Promptly Attended To

THE BRUCE FISHERIES

Breeder, Importer, Wholesale & Retail Dealer in

All Kinds of Goldfish
Comets a Specialty

ELGIN K. BRUCE, THORNBURG, IA.

CALICO TELESCOPE YOUNG

\$5.00 per Dozen

Try I. X. L. Baby Fish Food Red & African Snails 50c per Dozen

WILLIAM E. WALP

1309 North 55th Street, Philadelphia

ONCE YOU TRY, YOU ALWAYS BUY
Gnad't's Perfect Fish Food, 10c a Box

Pulverized or Whole Shrimp, 75c lb.

BREEDER OF FANCY GOLD AND TROPICAL FISHES

Manufacturer of all kinds of aquariums

Fish nets made of finest netting, 15c.

Great reduction by dozen or gross.

BROADWAY BIRD STORE

P. F. GNADT, Prop.

1632 Broadway Greenhouse 1630 Broadway
BROOKLYN, N. Y.

Aug. C. Freitag & Son

Aquarists

Mollienisia latipinna; Domesticated

(Not Sold in Wild State)

Chamelions, Turtles, Alligators, Etc.

PRICES QUOTED CORRESPONDENCE SOLICITED

223 - 225 BOURBON STREET
NEW ORLEANS

"AQUARIA FISH"

A Practical work on care and breeding of
fish in the Aquarium, Greenhouse and out-door
Ponds. Finely illustrated.

Everyone interested in keeping fish should
send for a copy of this book, price, \$1.

FOR SALE—A limited number of Red
Squirrels, Chipmunks or Striped Ground
Squirrels, Cotton-tail Rabbits and White
Bellied Deer Mouse.

F. L. TAPPAN

92 S. 7th Street, Minneapolis, Minn.

EDWARD S. SCHMID

Emporium of Pets

ALL KINDS OF GOLDFISHES AND AQUATIC PLANTS AND
WATER LILIES

712 Twelfth Street, N. W., Washington, D. C.

Taxidermy

Send for Catalog

THE BOOK OF WATER GARDENING—By Peter Bisset

200 pages, illustrated. Contains all the
practical information necessary to the selec-
tion, grouping and successful cultivation of
aquatic and other plants required in the mak-
ing of a water garden and its surroundings.
A book that should be in the library of every
fish breeder. Price, \$2.50. Postage paid.

Address Aquatic Life, 542 E. Girard Avenue, Phila. Pa.

DRIED SHRIMP (Ground 75c per lb.)

Postpaid

Special Price on Quantity Lots

My Natural Fish Food, Sample can 15c Per Pound \$1.00

CANADIAN BIRD STORE

2139 W. Van Buren Street

Chicago, Ill.

WALTER BELL

Breeder of Broad-tail Telescopes

BLUES

BLACKS

CALICOS

4324 WYALUSING AVENUE, PHILADELPHIA

Prices Reasonable

Books for Aquarists

THE HOME AQUARIUM and How to Care
for It. A guide to its fishes, other animals
and plants. By Eugene Smith. 213 pages
137 illustrations, cloth binding.

\$1.20. Add parcel postage on two pounds

THE FRESHWATER AQUARIUM and Its In-
habitants. A practical work for the aquarist.
By Eggling and Ehrenberg. Freely illus-
trated, 352 pages, art cloth binding.

\$2.00. Add parcel postage on two pounds.

Address Aquatic Life

(Book Department)

542 E. Girard Avenue, Philadelphia

PRINCELY RECOGNITION

15 West 67th Street, New York, N. Y.

June 2, 1916.

Dear Mr. Brind:

I have read with much interest and I am glad to have your books on "DOMESTICATED FISH" with the very valuable information they contain, for I have been interested in Aquaria for a long time, affording as they do the observation of a corner of Nature so little known as to be mysterious and so full of fascinating beauty.

Sincerely yours,

(Sd.) Prince Pierre Troubetzkoy.

NOTE!—Only a limited number of copies of above work remain and may be had by sending \$2.60 direct to the author and publisher

W. L. BRIND, F. Z. S.

(who has now MOVED from Bergenfield) to 449 West 206th Street, New York City, where old friends and new customers will be welcomed (evenings only!) By appointment: Phone, 8418 St. Nicholas.

Direct Importations of Fish, Reptiles, Plants, & MOTION PICTURE FILMS OF FISH, ETC., MADE AND SOLD
\$10 to \$100 each.

VIOLET RAY FISH REMEDY

Relieves Constipation, Fungus, Tail Rot, Congestion. Safe and effective. Box of six powders 25c. For sale at Pet Stock Stores, or address

REGENIA CHEMICAL CO., Sta. K, Philadelphia

THE TERMINAL PET SHOP

PETS OF EVERY DESCRIPTION AND KIND

Manufacturing and Maintenance of Aquariums a Specialty
All Kinds of Cat and Dog Foods and Medicines

Hudson Terminal Building
Concourse, NEW YORK

Broad-tail Telescopes

Correspondence Solicited

GEORGE WILT, 1519 N. 62d Street
PHILADELPHIA

TEN VARIETIES OF BEAUTIFUL AQUARIUM PLANTS

for \$1.00 Postage Prepaid

J. HENRI WAGNER, 1909 North Capitol
Washington, D. C.

Aquatic Life

Volume One

WILL BE READY for distribution about October 1st, bound in cloth with title page and index. Price \$2.00 postpaid.

Address **Aquatic Life**

(Book Department)

542 E. Girard Avenue Philadelphia

MILWAUKEE TRIPOD CO.

457 Eleventh Street Milwaukee, Wis.
W. C. EVANS, Manager.

Manufacturer and repairer of aquariums. Dealer in all kinds of aquarium fishes and plants. Imported Japanese and Chinese goldfishes.

FRANKLIN BARRETT

EVERYTHING COMPLETE FOR THE
AQUARIUM, POND AND LAKE

Wyoming Avenue, & C Street, Phila., Pa.

SEND FOR PRICE LISTS

"Everything is Fish that comes to the Net of a Naturalist"

Don't paddle in the water with one hand and be blind with both eyes.

In other words, "keep your eyes open" for all nature.

OUR MAGAZINE

The Guide to Nature

WILL HELP YOU

It is edited by Edward F. Bigelow, who fishes in the heavens and earth, as well as the waters under the earth.

Single copy, 10c.
Four months' trial, 25c.
One year, \$1.00.

THE AGASSIZ ASSOCIATION
ArcAdia

Sound Beach

Connecticut

IF YOU

Are Looking for Something Extra
Fine in Broad-Tail Telescopes

Don't Forget W. H. HEIMBACH

Breeder and Importer of FINE FISH

Snails Plants

FISH FOR SALE AT ALL TIMES

413 NORTH 10TH STREET

ALLENTOWN PA.

HERMAN RABENAU, Aquarist

PERMANENT DISPLAY OF

Aquatic Life and Terraria

must be seen to be appreciated

Visitors Welcome

Plants and Tropical Fish a Specialty

Importations of New Varieties received
regularly

1163 Myrtle Avenue, Brooklyn, N. Y.
Near Broadway.

Nippon Goldfish Co.

1749 Buchanan St., San Francisco, Cal.

Importers and Dealers

JAPANESE GOLDFISH

DIRECT FROM BREEDERS IN JAPAN

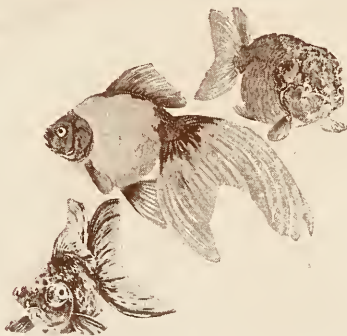

AWARDED GOLD & SILVER MEDALS

Panama-Pacific International Exposition
San Francisco, 1915

All Kinds of AQUARIA & SUPPLIES

Price Lists Furnished to the Trade Only

Harry P. Peters

1210 N. Warnock Street, Phila., Pa

BREEDER AND IMPORTER.

Rare and Fancy Fish

Plants, Snails and Aquarium Supplies
of All Kinds at All Times.

MANUFACTURER OF

Green River Fish Food

10c a Box

Green River Baby Fish Food

15c a Box

A GOOD FISH FOOD is one of the most essential things necessary to keep fish in good health. After the test of years Green River stands out as the best food on the market. It keeps the fish in good color by promoting a healthy, robust growth. It will not sour or cloud the water. Ask your dealer or send for it today.

Young Blue, Black and Calico
Telescopes and Japs \$1.00 per
dozen Up.

Also Veil-tails, \$5 per Dozen Up

Shipping Can, 25c Extra

HARRY P. PETERS

1210 NORTH WARNOCK STREET

PHILADELPHIA

Otto Walter

86 Suydam Street :: Brooklyn, N. Y.

Near Evergreen Avenue L Station

Breeder and Importer of

TROPICAL AND GOLDFISHES

Telescopes Calicos Japs Fan-tails

Dealer in All Varieties of Aquatic Plants
Water Violets My Specialty
All Kinds of Fish Foods
Fresh and Dried Daphnia

AQUARIA, UTENSILS AND SUPPLIES

October, 1916

10c Copy

Aquatic Life



J.H. Goodby
M.L. 1916.

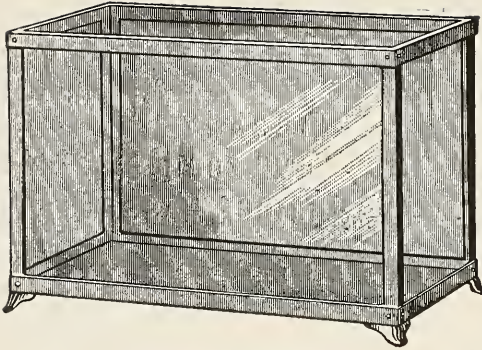

Jacob C. Cassel
915 Arch Street, Philadelphia, Pa

Manufacturer of

AQUARIUMS

Aquarium Ornaments

Floral Terra Cotta, Etc.

Goldfish Fish Globes Fish Food
and all aquarium requisites.
Send for Catalog.

Aquarium Specialty Co. 1873 WASHINGTON AVENUE
NEW YORK CITY
MANUFACTURERS OF AQUARIA, FOUNTAINS, TERRARIA, VIVARIA
BREEDERS OF DOMESTICATED FISHES
IMPORTERS OF FOREIGN FISHES
AQUATIC PLANTS, SNAILS AND SUPPLIES
STOCK AQUARIA

Galvanized Metal Frame, Enameled
and Gold-Striped, Bottom Slate or
Ribbed Glass. Plain. On legs

No. 1.	11"x7"x7"	\$1.25	\$1.50
" 2.	14"x9"x9"	1.50	2.00
" 3.	17"x11"x11"	...	2.25	2.75
" 4.	20"x13"x13"	...	3.00	3.75
" 5.	24"x12"x14"	...	4.75	5.50

20% additional for oxidizing.

Solid Brass Frame, on Projecting
Slate Bottom or on Legs.

No. 1.	12"x 6"x 8" high,	2½ gal.	\$2.50
" 2.	14"x 8"x10"	" 5 "	3.25
" 3.	16"x10"x12"	" 9 "	4.75
" 4.	18"x12"x14"	" 14 "	5.75

20% additional for nickel-plating or
oxidizing.

Steel Angle Frame, Heavy Plate
Glass, Slate Bottom, Flush or Pro-
jecting.

No. 3½.	24"x14"x14",	22 gal.
" 4½.	30"x16"x16",	36 "
" 5½.	36"x18"x18",	54 "
" 6½.	42"x20"x20",	80 "
" 7½.	48"x22"x22",	110 "
" 8½.	54"x24"x24",	145 "
" 9½.	60"x26"x26",	180 "

All our aquaria are so constructed
that water cannot come into contact
with the metal.

All sizes and shapes made to order.
We charge only actual cost for pack-
ing and cases.

FISH FOODS

	Per Tin box.	Per lb.
Natural Fish Food.....	\$.10	\$.50
Universal Fish Food...	.15	2.00
Ground Dried Shrimp..	.10	1.00
Ground Dried Flies and Insects20	3.00

	Per Tin box.	Per lb.
Ground Dried Daphnia.	\$.20	\$3.00
Whole Ants' Eggs.....	.10	1.00
Ground Hulled Ants' Eggs25	4.00
Infusoria Creating Food	.15	2.00

Correspondence Solicited. JOSEPH TAUBLES, Manager. No Catalogues

IF YOU

Are Looking for Something Extra
Fine in Broad-Tail Telescopes

Don't Forget W. H. HEIMBACH
Breeder and Importer of FINE FISH
Snails Plants

FISH FOR SALE AT ALL TIMES

413 NORTH 10TH STREET
ALENTOWN PA.

MECCO GARAGES
Here is a chance
to make money
Write for Proposition
Give References
— ADDRESS —
M. E. Corrugating Co.
COVINGTON,
KENTUCKY



THE BITTERLING

C. J. HEEDE



Rhodeus amarus

Photo by Dr. E. Bade

The Bitterling or Bluefish, *Rhodeus amarus*, is a native of Central and Western Europe and some parts of Asia. This carp-like fish is a very interesting inmate of the aquarium, and, though but little known in the United States, is much admired by European fanciers. It is bright silvery in color, with a bluish-green stripe running from the head to the tail. The fins are pinkish. During the breeding season, which occurs from April to July a great change occurs in the coloration of the male. He is now adorned with beautiful markings of steel-blue, violet, green and yellow—the colors of the rainbow. The dorsal and anal fins become bright red with black linings; tubercles develop on the pectoral fins and gill covers. The female retains her usual color and protrudes the long, worm-like

ovipositor. A mature fish will measure from two to two and one-half inches in length.

The aquarium in which it is proposed to breed the Bitterling should be provided with a sand or gravel bottom. One or two freshwater mussels must be introduced, either the pond mussel, *Anadonta mutabilis*, or the river mussel, *Unio pictorum*. Rather small ones will be best as large mussels might be able to eject the spawn. By means of her long tube or ovipositor the female inserts the eggs, two at a time, in the gill opening or aperture of the mussel. The milt of the male discharged immediately, just above the mussel, finds its way to the eggs and fertilizes them. The fry leave the foster mother, the mussel, within a period of ten to fifteen days after the spawn has

been inserted. In the meantime the young have absorbed the yolk-sac and are now searching for infusoria. Later they will need Daphne, Cyclops, raw scraped beef, crushed earthworms or artificial foods. The Bitterling will not breed except in the manner described.

After the spawn has been deposited in the mussel, the safest plan is to remove the parent fish to another tank containing a new mussel or two. They will soon start spawning again. To remove the mussel may enable it to throw out the spawn or fry, though nature has provided the little bitterlings with appendages on each side of the back of the head which enable them to a certain degree to hold fast.

In its native haunts the Bitterling lives in cool, clear, running water. A single pair may be kept in a well-balanced aquarium of good size, and will thrive, but if many pairs are desired, some running water or a working fountain is necessary. This species requires a good supply of oxygen, and if the tank is deficient, will try to leap out at every opportunity. The temperature of the water should be from 60 to 65 degrees, Fahrenheit, which is high enough for breeding.

The interesting method of reproduction, fine nuptial dress of the male, hardness and low cost have served to place the Bitterling in nearly every home aquarium in Europe. They can well be compared with many a costly tropical fish.

Community Aquaria

JOSEPH TAUBLES

In the opinion of the writer the most interesting aquarium is one that contains a variety of fish life. That this is generally entertained is attested by the numerous inquiries relative to the species that can be associated in a tank and live peace-

fully together. Out of many attempts by my friends three stand out prominently:

Mr. William H. Heimbach, in a tank measuring 48 by 20 by 20 inches, having a dense growth of rooted plants and plenty of *Utricularia* (Bladderwort), has successfully kept nearly every kind of exotic aquarium fishes—live-bearers, egg layers and nest builders. Many fishes may be kept in such a large tank that one would not wisely associate in a small one. This aquarium was maintained at an average temperature of 75 degrees, Fahrenheit.

Another aquarium, measuring 36 by 20 by 18 inches, contains seventeen goldfish of the fancy breeds, no two alike, together with *Xiphophorus helleri*, *Osphromocycus koelreuteri*, *Callichthys marmoratus*, Rosy-sided and Red-bellied Dace. Temperature, 64 to 75 degrees, Fahr. The owner of this tank has a hybrid derived from *Girardinus guppyi* and *Xiphophorus*. The fish is about twice the size of a male *guppyi*, similar in shape, but having a helleri-like tail, the spear of the caudal outlined with black. Coloration, yellow, green, blue and red—the yellow and green more intense than with the parents. It is a wonderful fish, and I have been promised some young.

The third community tank, owned by a man fond of colors above all else, measures 24 by 12 by 14 inches, and contains males only of the following species where sex is distinguishable: *Girardinus guppyi*, *Xiphophorus helleri*, *X. brevis*, *X. ranchozii*, *Platypoecilia maculata*, *P. pulchra*, *P. rubra*, *Haplochilus rubrostigma*, *H. chaperi*, *Gasteropelecus stellularis*, *Danio rerio*, *D. analipunctatus*, *D. albolineatus*, *D. malabaricus*, *Barbus conchoni* and *B. semifasciatus*.

Tom (writing to Ted)—“As for the perch, they bit with their usual veracity.”

The FRESHWATER MUSSELS

L. R. JOHNSTONE

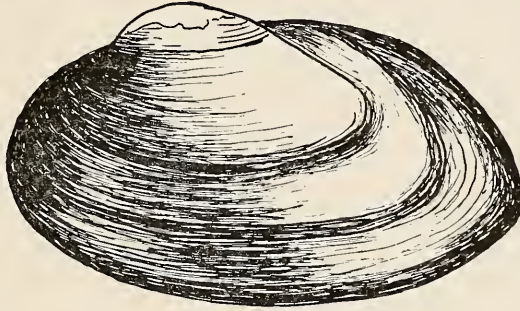

Unio complanatus

Drawing by Frank L. Tappan

The Bivalves, to which belong the fresh water mussels, comprise a large division of the MOLLUSCA, the majority of which are marine. The fresh water species may be found in most rivers, lakes and large ponds, where they plow their way through the mud, feeding on minute unicellular plants and animalcules. Their blood is aerated by means of large gills, through which the water is drawn by cilia or hairs. Sensory papillae are placed around the inhalent aperture—the large opening at the hinder part of the animal. Another small, round opening, the exhalent aperture, through which the water is returned and refuse expelled, is placed just above the inhalent aperture. Respiration consists in taking the water through the inhaling aperture or syphon and passing it over and between the gills, and thence out of the body through the exhaling opening. These water currents reach the other organs, aerate the blood, convey food to the stomach and

carry off the waste materials of the system.

The reproduction of the freshwater mussels is especially interesting, and illustrates in a remarkable way the interdependence of organisms. The sexes are separate. The eggs are produced in spring and pass into the water-tubes of the gills in such numbers as to distend them like cushions. Here they remain for the first stages of development to take place, which may be completed in two months. The embryos now become quiescent and pass the winter in the brood pouch. In the following spring they leave the brood pouch and pass out through the upper or exhalant opening into the water.

The young, which are now known as Glochidia, are small creatures with a bivalve shell, having a hook on each valve opposite to the hinge, a single muscle to close the valves, and a silk-like thread just behind it. They swim by flapping their valves rapidly, and eventually close

them on the gills or fin of a fish, where they are firmly attached by hooks. They remain attached as parasites on the fish for some weeks (in some cases, months) and undergo further development. After leaving the fish they are still not fully formed, as they take about three years to obtain all their gills, and another two years before they are sexually mature, growth continuing all the while. Usually the various species of mussels have particular fish, or families of fishes, as hosts, only upon which the glochidia will grow. They will attach themselves to most any fish that touches them, but will fall off from all but their proper hosts. Professors Needham and Lloyd, in the "*Life of Inland Waters*," say that "The part taken by the fish in the association is truly remarkable. The fish is not a mere passive agent of mussel distribution. Its tissues respond to the stimulus of the glochidia in a way that parallels the response of a plant to the stimulus of a gall insect. As the plant develops a gall by new growth of tissue about the attacking insect, and shuts it in and both shelters and feeds it, so the fish develops a cyst about the glochidium and protects and feeds it. The tissues injured by the valves of the glochidium produce new cells by proliferation. They rise up about the larva and shut it in. They supply food to it until the metamorphosis is complete, and then, when it is a complete mussel in form, equipped with a foot for burrowing and with a good system of nutritive organs, they break away from it and allow it to fall to the bottom. Since this period lasts for some weeks, or even in a few cases, months, the fishes by wandering from place to place aid in the distribution of the mussels." The glochidia seem to do little or no harm to the fish. The cysts are eventually cast off and leave no scar.

In conclusion it must be stated that not

all mussels have a life-history agreeing with the foregoing outline. A few species are not parasitic and develop to the adult form in the brood chamber of the parent.

Unio complanatus, a drawing of a valve of which is reproduced by permission from Frank L. Tappan's "*Aquaria Fish*," is a very common species which occurs in almost every stream and river on the Atlantic slope. The shell is usually a yellowish-green in young specimens and brownish-green when mature. A full grown individual will measure three inches long, two inches broad, and one inch thick near the hinge. This *Unio* is an active mussel, often moving several inches in a day. It is an interesting scavenger and if placed with compatible fishes will live in the aquarium for years.

The Aquarist Avoids

Changing the temperature of the water, carrying about a fitted aquarium, placing beetles or water spiders in the aquarium with fishes, putting sea shells, corals or marine specimens in a fresh water aquarium, using soap or chemicals to clean the tank (use whiting and salt), throwing a fish into the water, introducing a doubtful specimen without quarantining, leaving uneaten food to dissolve and pollute the water, tapping on the glass, using a deep, funnel-shaped net, putting the hand in the water unnecessarily, allowing any tobacco from the hand to go into the water, many persons taking care of one aquarium; small, round glass globes, except for small tropical fishes, strong sunlight, keeping diseased fishes with healthy ones, needless disturbance of aquarium and contents.

Now that the hot wave's put to rout, we soon will get together, and kick and cuss as hard about the cold autumnal weather.

PROPAGATING DAPHNIA

JOHN L. BENNINGTON



AN ATTRACTIVE HOUSEHOLD AQUARIUM

Photograph by George H. Seip

When the subject of raising Daphne is broached, the goldfish breeder smiles merrily. From his viewpoint, it can't be done, he uses too vast a quantity. Now Daphne *can* be propagated, and in quantity, but not with the facilities possessed by the average city goldfish fancier. It is entirely a matter of adequate pond space and food. The Japanese do it, but they devote, in some cases, as much space as to the fish. This is considerable, because a fish pond in Japan will sometimes have a surface area of more than 150 square yards!

The food of Daphne is mainly the smaller green algæ and diatoms. If these can be supplied we can breed it. In nature they reproduce rapidly, very rapidly, in fact, it has been calculated that the progeny of a single female *Daphnia pulex*, in a period of sixty days, might number 13,000,000,000. This because the young develop rapidly and are themselves soon producing eggs.

Barring the Japanese, most articles

dealing with Daphne breeding have been written by fanciers of exotic fishes. I know of no successful experiments that have yielded sufficient water-fleas to feed a thousand, yes, even a hundred, goldfish to an age of six months. It could be done, but not without large pond space.

Various writers have in the past outlined their methods of culture. Myers, starting in September, raised sufficient throughout the winter to supply a dozen goldfish with a liberal feed once a week. He used a twelve-gallon aquarium, in which he placed about a quart of *Spirogyra* and *Cladophora* (filamentous algæ commonly called "frog-spit." These or allied species are usually abundant in swamp waters). These algæ grew and furnished the young and old Daphne with abundant food. Brind advises the use of quart preserving jars, having a bottom of soil and containing bits of plants. A large number of jars are prepared, and the "bugs" used from them in rotation. Gage uses a porcelain-lined kitchen sink,

the outlet of which has been carefully plugged. In it is placed an inch and one-half layer of rich loam, then a light sprinkling of dried sheep manure, covering this with a half-inch of earth containing a fairly high percentage of clay. Ripe or old aquarium water is then added. The sink is filled liberally with

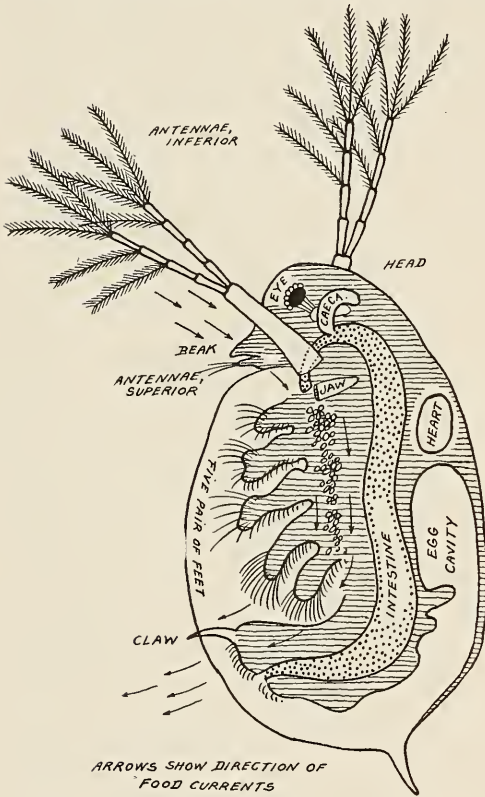

Daphnia pulex (greatly enlarged)
Original Drawing by Frank J. Myers

any of the recognized aquarium plants. Several heads of lettuce, sun-dried and powdered, is sprinkled over the surface of the water. Then, after a few days, some *Daphne* is introduced and their multiplication commences. From time to time decayed plants such as will be removed from aquaria should be thrown in.

Compared with goldfish, the tropical fishes are rather small, and in consequence consume less. Any of the fore-

going plans should provide enough for feeding tropicals, but only a tithe for a goldfish. The average breeder of the latter fish, if he has a fair number, will consider a *Daphne*-collecting trip a failure unless he carries home a bulk equivalent to a teacup filled solid. To propagate enough to feed such a quantity daily would require a pond exceeding in area his home grounds. While this amount seems large, it must be remembered that the first rule of breeding is to keep the young "filled," and, further, that a goldfish in early life is capable of consuming daily a quantity of *Daphne* equal to its own bulk. The Japs, to propagate *Daphne*, will take a pond with an area of 150 yards or more. If the pool is over ten years old, five bushels of rice bran, soy lees or the excrement of man or horse are spread upon the bottom after it has been drained. This is exposed to the sun's rays for about a week, and then the water is replaced. If the pond is less than two years old double the quantity of fertilizer used. This method would seem to be quite malodorous, and one to be avoided by the fancier who lives, as most do, in close proximity to fellow-men. In short, it would seem that the breeder of goldfish will do well to continue gathering *Daphne* in the ponds of the city "dumps," leaving its propagation to the tropical fish lover, whose demands are more easily met.

Natural objects are being threatened with extinction in Italy, as elsewhere. A league has been formed, therefore, for the protection of the fauna and flora of the country, and of such geological and geographical features as are of scientific or esthetic interest. A zoologist, a botanist, a geologist, a geographer and an agriculturist are included on the executive council.

Fishes and Reptiles in Winter

ANNA K. BEWLEY



YOUNG MIRROR CARP

The Carps are Hardy and Excellent Fishes for the Beginner
Courtesy of the New York Zoological Society

Much has been written on the hibernation of mammals, fishes and reptiles, and it has ever been a fascinating subject to those interested in the study of natural history. That quaint and charming writer and observer, Reverend Gilbert White, of Selbourne, was much interested in the subject. In a letter written to Thomas Pennant, in 1774, he refers to the hibernation of the carp as follows: "In the garden of the Black Bear Inn, in the town of Reading, is a stream or canal running under the stables and out into the fields on the other side of the road; in this water are many carps, which lie rolling about in sight, being fed by travelers, who amuse themselves by tossing them bread; but as soon as the weather grows at all severe these fishes are no longer seen, because they retire under the stables, where they remain till

the return of spring. Do they lie in a torpid state? If they do not, how are they supported?" He also suggests the possibility of the hibernation of the swallows, and we have not learned—even to this day—where they do pass the winter, although we are pretty sure they do not hibernate.

All of the reptiles and many of the fishes of the cold zones become torpid and pass the winter in a state of hibernation when their food is scarce or unobtainable. They are said to be in a state of coma, in which all the functions of life are suspended for the time, and no food is taken. While it has been asserted that they die very easily if exposed to too low a temperature, Mr. Sanford Omensetter, writing in the "Proceedings of the Delaware County Institute of Science," makes the statement that "reptiles have been

kept in a torpid state for three years and a half, and have at the end of this time been readily revived." Frogs of certain kinds are known to pass the winter in the mud under water, while others find refuge only a few inches under the dead leaves in the woods. Salamanders and lizards when found in winter under logs or stones do not appear to be in a dormant state, but scurry away as lively as ever. The common Wood Tortoise burrows in the leaves, while the aquatic species go to the deeper water or bury themselves in the mud, where they remain until the coming of spring. They, like all other creatures that hibernate, prepare for this long fast by getting "extra fat" in the fall, and are considered at this time very good food. Some varieties of serpents hibernate intertwined together in large numbers. The common Garter Snake is an example.

The carps, as well as many other fishes, are known to pass the winter in hibernation, and, although they are not entirely torpid, they are said to live without food, except in warm climates. The bass may not take food during the winter even in an aquarium, and does not grow. Although in these cases, and with the turtles and frogs, much depends upon the particular species, since different habits characterize the various kinds. Eels will migrate to the sea when they can, but have been found in the mud during the winter when migration was not possible.

The Gilt Edge Aquarium

With the caption, "An Attractive Household Aquarium" is shown, on page 19, a tank of more than passing interest. The burnished frame hangs upon that of the aquarium and conceals it, so that one views an actual living picture. On first thought one might consider that the frame defeats its purpose, detracting at-

ention from the contents, but in reality the seeming weight is more that counter-balanced by the quantity of plants. Particularly noteworthy is the beautiful mass of *Potamogeton* on the right. Its size can be best appreciated by comparison with that of the tank—four feet long by twenty inches deep. In the background appears *Sagittaria sinensis*; centre, *Cabomba caroliniana*; right, *Ouziran-ara fenestralis*, the Madagascar Lace Plant, thrusts its latticed leaves above a dense growth of Italian *Vallisneria spiralis*, *Heteranthera zosteræfolia*, *Ludwigia mulleritti* and several other species. At night the tank is illuminated by a number of miniature electric lights, distributed over the cover-glass and under an opaque roof. These cast a soft glow on the life below, and complete a picture that is hard to describe adequately. It has received a number of high awards, including a silver cup, in household aquarium contests.

To photograph an aquarium a rather long time exposure is usually productive of the best results, hence the fishes must be removed: in fact, it is well to do so the day previous, to allow all sediment to settle. The aquarium shown had been established several months before the photograph was made.

One of the largest recorded specimens of the ray or devil-fish was found some time ago in Delaware Bay. The monster measured seventeen and one-half by eighteen feet, and weighed five tons—eleven thousand two hundred pounds. An elephant weighs between three and four tons.

Heard some one say the Quaker City was slow! Suggest you attend the coming meetings of the two societies. Wager you change your mind!

Conservatory Heat Regulation

E. J. WILCOX

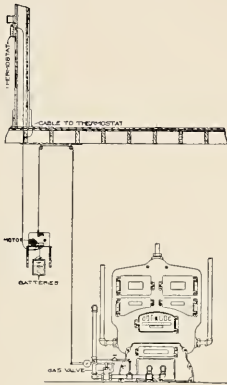

Fig. 1



Fig. 2

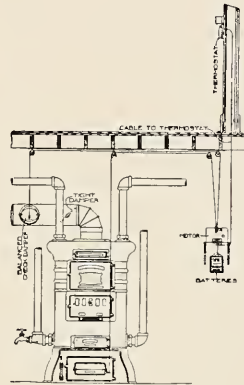

Fig. 3

Heating the conservatory for tropical fishes is a serious problem, because, unlike houses in which plants are grown, it is absolutely essential that it be kept warm at all times. A sudden drop in the temperature will work damage that cannot be repaired. Some conservatories are heated by gas, some by coal fires, others by steam, but the most satisfactory results are obtained with a hot water system. The operation of any of these systems is so well known as to remove all necessity for description. Heating during the day is a simple matter, but for the night it is the custom to "bank the fire" and trust to luck. Without doubt you recall the many times when, arriving home late at night, your first thought was of the conservatory. If the temperature out of doors does not fluctuate very much, that within the house may not reach low danger mark. However, by the use of a very simple apparatus, the temperature can be automatically maintained at any predetermined degree, both

night and day, provided the fire is occasionally fed and cleaned. This is accomplished by a comparatively inexpensive thermostatic regulator.

The source of heat supply may be at any point distant from the conservatory, but the thermostat must be installed in the room or building to be heated. This instrument, which is illustrated as Figure 2, is attached to the wall. It should be placed at a neutral point—not near a radiator, a window or on an outside wall—and about four or five feet from the floor. The regulator is small, handsomely finished, measuring about eight inches high. It contains a blade composed of two metals, which moves between two electrical contacts as the heat or cold causes it to contract or expand, thereby permitting the transmission of the current from two dry batteries through a fine cable to the motor, which is placed near the furnace or heater. The motor, upon receiving this current, will open or close the drafts. Protecting the blade of

the thermostat will be observed a case on the face of which is set a dependable thermometer. The small pointer at the bottom is a lever which enables one to set the instrument for any desired temperature, from 55 degrees to 85 degrees Fahrenheit.

The clock, in addition to being an accurate timepiece, has an added function. It may be desirable at times to maintain a slightly lower temperature, especially during the night. This can be accom-

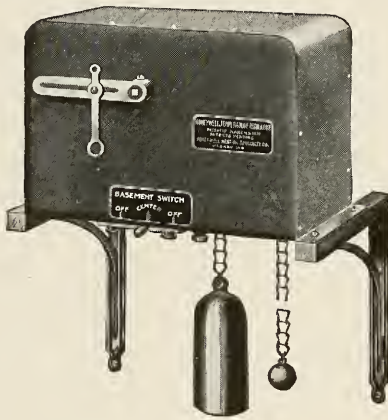

Fig. 4

plished by setting the lever at the bottom to the desired degree, then setting the clock to a determined hour, say 6 A. M., at which time the clock will automatically throw the lever to 70 degrees, and by the time we are ready to come to the conservatory the fire will be burning brightly, may be fixed for the day, and the place is warm. A type is manufactured with an eight-day clock which will not only throw the lever forward in the morning at any desired hour, but at night will reverse the operation and set it back again. The thermostat may also be had without the clock.

The thermostat, as previously stated, is connected with the motor by a cable of three fine wires, the electric current being furnished by two dry cells. The gravity type of motor is illustrated by Figure 4.

With this type it is necessary to pull up the weight each day. Spring motors operating for a week, and electrical motors which require no attention, can also be procured.

Assuming that a temperature of 75 degrees is desired, the apparatus will keep the drafts on until this is reached, and then without human aid, automatically check the fire until the temperature drops to 74 degrees, when the drafts will again be opened. To say nothing of its almost human intelligence and convenience, the saving in fuel is a big item. It can be readily seen that the fire is not allowed to burn, perhaps for hours, after the place has been sufficiently heated. Nor will it allow the fire to go down and perhaps out on a cold night. A sudden drop in the temperature at any hour is cared for without any forethought on the part of the owner.

Figure 3 illustrates in detail the application of the apparatus to a hot-water heater, while the same connections exactly would be made for a hot-air furnace. Figure 1 shows its application to a rather elaborate gas connection, but it can be equally well arranged to operate with a single gas burner.

The motor is so equipped in the spring and gravity types that it cannot run down and leave the fire on should one forget to wind the spring or pull up the weight, as the case may be. The last act of the motor, before automatically cutting off the electric current, would be to shut off the fire. Winding the motor, or pulling up the weight, will reconnect the current, and the operation of the regulator will proceed as before.

The installation of this simple outfit renders the possibility of temperature changes very remote indeed. It is an almost indispensable accessory of the conservatory for fishes. While many makes are obtainable, that manufactured

by the Honeywell Specialties Company, of Wabash, Indiana, through whose courtesy I am enabled to present the accompanying illustrations, is known by the writer, after several years' experience, to be unusually efficient for operation in connection with tropical fish maintenance.

The Nurse Shark

The curious, pig-like habit of the nurse sharks of Florida have been brought to the notice of the North Carolina Academy of Science by E. W. Gudger. A third of the circumference of Boca Grande Cay, a small coral sand island twenty miles west of Key West, is bounded by a gently sloping rock bottom, on which the water half a mile from shore is not more than four or five feet deep, and on this bottom great numbers of the sharks gather to bask in the sun, play, breed and possibly feed. With seldom less than a dozen visible, as many as thirty-three have been in view at one time. They are broad, sluggish, so little afraid that a boat may touch their fins before they will move, and they lie piled together in a confused herd, like well-fed pigs in a barnyard. Sometimes three or four together swim aimlessly about. They are harmless, with small mouths filled with small, pointed teeth, and though omnivorous, their food seems to be chiefly crustaceans.

Educating the Goldfish

He found his own front porch with wonderful accuracy, navigated the steps with precision, and discovered the key-hole by instinct. Once in the dimly-lighted hall there was an ominous silence, followed by a tremendous crash.

"Why, what has happened, Henry?" came a voice from above.

"It's all right, Mary, but I'll—I'll learn these goldfish to snap at me!"—*Everybody's*.

Vallisneria Spiralis

J. CHAS. WOBLER

There are just a few aquarium plants that rank in efficiency with *Vallisneria spiralis*, the Eel-grass, Tape-grass or Wild Celery. Given a little sunshine, or even without, it grows remarkably fast, producing new plants from its creeping

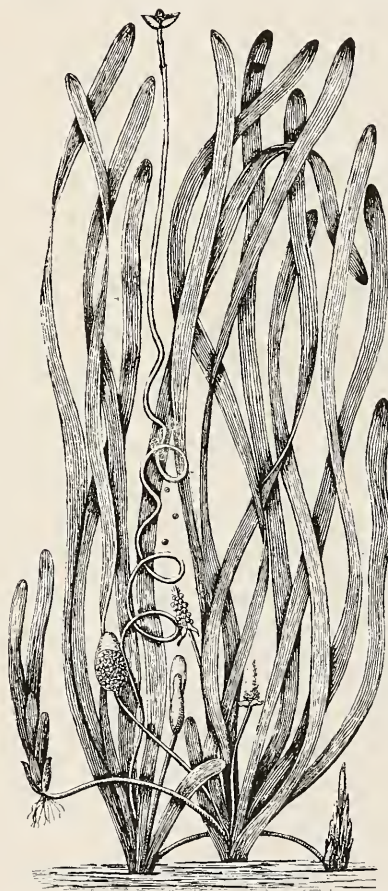

Vallisneria Spiralis

From Wolf's "Goldfish Breeds"

stems or stolons, and rapidly forming thickets of bright green; sometimes half a dozen plants will be found strung together. It suffers somewhat when compared with *Sagittaria*, because its leaves are more tender and easily broken in transplanting, otherwise it is equally good. In general it seems to prefer more sunlight than *Sagittaria*, and a shallower

Aquatic Life

A monthly magazine devoted to the study, care and breeding of native, tropical, gold and fancy fishes, other animals and plants in the household aquarium.

W. A. POYSER Editor
 JOSEPH E. BAUSMAN Publisher
 542 E. Girard Avenue, Philadelphia

Entered as second-class matter September 2d, 1915, at the Postoffice, Philadelphia, Pa., under Act of March 3d, 1879

Yearly Subscription \$1.00
 Foreign Subscriptions 1.35
 Single Copy 10 cents

Payments may be made by express money order, draft, postoffice order or registered letter. Foreign remittances should be by international money order.

Advertising rates made known on application. Aquatic Life is the only magazine in America devoted exclusively to aquatic life, and its value as an advertising medium in this field of nature study is unequaled.

Patrons will confer a favor by sending us the names of responsible Pet Stock Stores who do not keep Aquatic Life on sale.

Copyright, 1916, by Joseph E. Bausman.

VOL. 2 OCTOBER, 1916 No. 2

tank. It can be readily distinguished by its bright green leaves, which are equal in breadth throughout their length, and blunt-pointed. *Sagittaria* is darker and thicker, the leaves somewhat pointed, and, though it is related, the flowers bear little or no resemblance to those of *Vallisneria*.

The sexual reproduction of *Vallisneria* is quite remarkable. Almost invariably submerged plants raise their flowers above water. When pollen-grains (the male element) come into contact with the water, with a few exceptions (as in *Ceratophyllum* and *Zostera*), they absorb so much as to cause them to burst, or to occasion the escape of their contents from one of their pores so quickly that they perish. *Vallisneria* overcomes the contingency in an interesting manner. This species is dioecious, that is, the sexes are separate, a plant being either male

or female. The male flowers are seated on very short pedicels or stems at the base of the leaves; the female flowers, on the contrary, on very long stems, which at a particular time become greatly elongated and raise the flowers to the surface of the water. The male flowers then become detached from their pedicels, rise to the surface, are floated among the female flowers, and fertilize them. After this has been accomplished the pedicel of the female flowers coils up spirally, and the fruit ripens beneath the water.

Three forms of *Vallisneria* are recognized. The most desirable is that known as "Dwarf Italian." The leaves may reach a length of eighteen inches. A horticultural variety, *Gigantea*, has a leaf

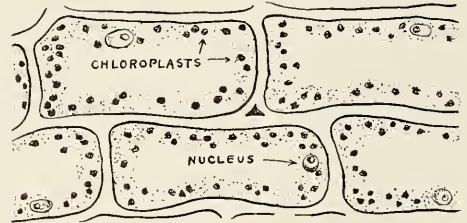

Cells from leaf of *Vallisneria spiralis* (greatly enlarged) showing chloroplasts—the Green coloring matter

half an inch broad, with a maximum length of about three feet, but it is reported to grow much longer. Both are much to be preferred to the common wild form. This latter, the typical species, in its natural state dies down in winter, but in the aquarium will grow throughout the year. It is widely distributed throughout the world.

Vallisneria spiralis, there is but one species in the genus, was first described and named by Linnaeus in his "Species Plantarum," published in 1753. The name was conferred in honor of Antonio Vallisneri, an Italian botanist; *spiralis* refers to the habit of the stem of the female flower.

The leaf-cells of *Vallisneria* are favorite objects among microscopists to illustrate the circulation of the protoplasm (life-fluid), and the chloroplasts which function in food-making.

NOTES & NEWS



A YOUNG MOOR OR BLACK TELESCOPE GOLDFISH

Owned by Geo. E. Wilt

Photo by H. W. Schmid

The first autumn meeting of the Philadelphia Goldfish Fanciers' Society was held on September 20th. Interest centered in the auction of fishes donated by members. The receipts from the sale, together with membership fees and dues, made a sum larger than any received at any former meeting.

The following were elected to membership: Mrs. Elizabeth C. Murphy, Messrs. Benjamin Funk, Stanley S. Anders, M. Nichols, Rudolph Pukall, Harry J. Mackrell, B. McQuaid, William Raroba, John Dove, M. Williams, Samuel W. Burgess, Thomas T. Mayne, George McGrath.

The next meeting will be held at Saull's Hall, 802 Girard avenue, on October 18th. The competition will be for Broad-tail Telescopes, scaled and trans-

parently scaled, over one year old. One cup and three ribbons will be awarded in each class.

Entries for the annual Household Aquarium Contest must be made at this meeting.

Mr. Charles E. Visel, of Brooklyn, one of our members, has presented a silver cup, to be awarded by the society to the member showing the best Calico Telescope. The date for this competition will be announced later.—Fred Richardson, Secretary.

The first part of a paper entitled "*Minute Inhabitants of Aquaria*," from the pen of Mr. P. B. Clark, San Francisco Aquarium Society, will be published in *Aquatic Life* for November. The

articles will be illustrated by numerous drawings by the author.

Replying to an inquiry regarding the identity of *soy lees*, which is used by the Japanese in the propagation of *Daphne*, Dr. Hugh M. Smith, U. S. Commissioner of Fisheries, answered "that soy is a very palatable sauce made from a bean. The thick part remaining in the bottom of the vessel is the lees, which correspond entirely with the lees of wine, beer, and various other liquids, and is synonymous with dregs."

Enchytrae, commonly known as white worms, form a valuable live food for all aquarium fishes during the winter months, when other items on the fish bill-of-fare, such as *Daphne*, are not to be had. It can readily be propagated in a small wooden box filled with soil. If a large supply is needed, several such boxes should be used, drawing upon the supply in each in turn. Every aquarist should maintain a "white worm farm."

A vandal recently threw a cigarette stump into an aquarium containing a number of fine fishes. Every one died. Be watchful of strangers.

Place the aquarium on a steady table or shelf opposite a northern exposure if possible, and if not, near the window having the least direct sunlight. Under a skylight will do, the main point being to obtain sufficient light to stimulate the growth of the aquatic plants without allowing the sun to shine directly on the water.—*Mark Samuels*.

A healthy fish exhibits a plump, symmetrical body, clean-looking fins, close-fitting gill-covers, complete erect dorsal fin, clear eyes, and no missing scales.

After the aquarium has been planted and filled with water it should be allowed to stand several days before adding the fishes; snails may be introduced at once.

Some native plants are good oxygenators; others are almost useless and soon become slimy, especially if they have been collected in cool, swift brooks. Unfamiliar plants should be watched.

The bag-tail is a type of fin development that apparently has not yet been found among American-bred goldfish. In this "sport" the upper and lower edges of the two tail fins are joined, forming a bag shaped like a cone.

The water in an aquarium will evaporate according to the temperature, more rapidly in a warm than in a cold room. When half an inch has evaporated, add an equal amount of fresh water. This water should stand in the room with the aquarium all night, so that it will attain the same temperature. A sudden change is bad for fishes, particularly in winter, and consequently care must be exercised to see that the waters are alike; this applies also when changing fishes from one tank to another.

The Lorquin Natural History Club, Los Angeles, has commenced publication of a monthly bulletin which has been called *Lorquinia*. Paul Ruthling is editor. It is sent free to members of the organization.

A Philadelphia aquarist reports a red, transparently-scaled goldfish, that contracted a disturbance causing half of its body to become inflamed and blood-red in color. No attempt was made to treat the fish, and within a week the inflammation disappeared.

Books for Aquarists

The Home Aquarium and How to Care for It. A guide to its fishes, other animals and plants. By Eugene Smith. 213 pages, 137 illustrations, cloth binding. \$1.20. Add parcel postage on two pounds.

Goldfish and Its Culture. Practical instructions for pond breeding, shipping, care of the aquarium, and the general subject. By Hugo Mullertt. 155 pages, 15 illustrations, cloth binding. \$2.00. Add parcel postage on two pounds.

Fish Culture in Ponds and Inland Waters. The most recent book covering the propagation of goldfish, food and game fishes, and aquarium management. By William E. Meehan, Director of the Fairmount Park Public Aquarium, Philadelphia, and former Pennsylvania State Fish Commissioner. 287 pages, 22 illustrations, cloth binding. \$1.00. Add parcel postage on one pound.

Japanese Goldfish. A guide to the Japanese methods of culture. By Dr. Hugh M. Smith, U. S. Commissioner of Fisheries. 10 full-page colored plates, numerous text cuts, 112 pages, cloth binding. \$2.00. Add parcel postage on two pounds.

Life of Inland Waters. Needham and Lloyd. A big book containing 438 pages and 244 splendid illustrations. It presents a survey of the whole realm of freshwater aquatic life. The only American publication on the subject, and one that will materially assist the aquarist in solving the many problems encountered. \$3.00. Add parcel postage on three pounds.

The Freshwater Aquarium and Its Inhabitants. A practical work for the aquarist. By Egging and Ehrenberg. Freely illustrated, 352 pages, art cloth binding. \$2.00. Add parcel postage on two pounds.

Address **AQUATIC LIFE**

(Book Department)

542 East Girard Avenue, Philadelphia

The Nature Study Review

OFFICIAL JOURNAL
AMERICAN NATURE-STUDY
SOCIETY

The numbers for the coming school year will be filled with special articles from practical teachers dealing with actual works, methods and suggestions for school gardening, elementary agriculture and nature-study.

DO NOT MISS ANY OF THEM

\$1.00 per year.

15c per copy.

SUBSCRIBE NOW

Add for Canadian Postage, 10c. Foreign
Postage, 20c. With Aquatic Life One
Year, \$1.50.

Address All Orders to

The Nature Study Review

ITHACA, N. Y.

THE BRUCE FISHERIES

Breeder, Importer, Wholesale & Retail Dealer in

All Kinds of Goldfish

Comets a Specialty

ELGIN K. BRUCE, THORNBURG, IA.

CALICO TELESCOPE YOUNG

\$5.00 per Dozen

Try I. X. L. Baby Fish Food Red & African Snails 50c per Dozen

WILLIAM E. WALP

1309 North 55th Street, Philadelphia

AQUARIUM STOCK CO.

150 Chambers Street, New York City

Aquarium Specialists

Goldfish, Foods, Plants, Snails, Etc.

Combination Natural Fish Food, - Sample Can 10c

Imported Shrimp Fish Food, - - - Sample Can 15c

Imported Wafer Fish Food, - Large Sample Box 10c

Special Prices on Quantity Lots Cash With Order

Sole Agents: for Floyd's Unexcelled Bird Food for
Birds to Restore Their Song - - - Sample Bottle 25c

ORDERS AMOUNTING \$2 DELIVERED POSTPAID

Mail Orders Promptly Attended To

Aquatic Life

Aquatic Life. Volume One. America's aquarian naturalists have collaborated to make "Aquatic Life" a practical cyclopaedia for the aquarist. The first volume, 166 pages, is complete. Every essential phase of this fascinating branch of nature-study is treated; special articles, splendidly illustrated, cover goldfish breeding, native and exotic species; the care of the aquarium, and the general subject. The illustrations, more than one hundred, some in color, include the finest that have ever been published of the various goldfish breeds. "Aquatic Life" is conceded the best illustrated aquarists' magazine in the world. The volume costs two dollars, postage prepaid.

Address *Aquatic Life*

(Book Department)

542 East Girard Avenue, Philadelphia

EDWARD S. SCHMID

Emporium of Pets

ALL KINDS OF GOLDFISHES AND AQUATIC PLANTS AND WATER LILIES

712 Twelfth Street, N. W., Washington, D. C.

Taxidermy

Send for Catalog

DRIED SHRIMP (Ground 75c per lb.)

Postpaid Special Price on Quantity Lots

My Natural Fish Food, Sample can 15c Per Pound \$1.00

CANADIAN BIRD STORE

2139 W. Van Buren Street

Chicago, Ill.

Aug. C. Freitag & Son Aquarists

Mollienisia latipinna; Domesticated

(Not Sold in Wild State)

Chamelions, Turtles, Alligators, Etc.

PRICES QUOTED CORRESPONDENCE SOLICITED

223 - 225 BOURBON STREET

NEW ORLEANS

"AQUARIA FISH"

A Practical work on care and breeding of fish in the Aquarium, Greenhouse and out-door Ponds. Finely illustrated.

Everyone interested in keeping fish should send for a copy of this book, price, \$1.

FOR SALE—A limited number of Red Squirrels, Chipmunks or Striped Ground Squirrels, Cotton-tail Rabbits and White Bellied Deer Mouse.

F. L. TAPPAN

92 S. 7th Street, Minneapolis, Minn.

R. PEGLOW

Dealer and Breeder of **Fancy Goldfish**

Broad-tail Telescopes My Specialty

All Kinds of Aquaria and Supplies

557 WOODWARD, AVE., BROOKLYN, N. Y.

ENCHYTRAE

The Secret of Successful Breeding of Tropical Fishes and the Ideal Live Fish Food.

Per Portion, 50 Cents, With Instructions How to Breed Them

CHARLES E. JENNE

109 22nd Street

West New York, N. J.



It is not the ingredients you use that makes a food nutritious but what nutriment is retained in its ingredients that makes a food valuable. Dried beef contains as much nourishment as fresh beef; fresh liver contains 16 per cent protein; when boiled it is bulk, no nourishment whatever. You see its in the making, not what you put in it.

Robert J. Schaeffer

1818 Frankford Ave., Phila. Sample 12c

USE REGENIA AQUARIUM SALTS

To replace natural salts in waters

as absorbed by fish and snails

6 POWDERS IN BOX, 25 CENTS

Regenia Chemical Co., Sta. K, Philadelphia

ONCE YOU TRY, YOU ALWAYS BUY Gnadt's Perfect Fish Food, 10c a Box

Pulverized or Whole Shrimp, 75c lb.

BREEDER OF FANCY GOLD AND TROPICAL FISHES

Manufacturer of all kinds of aquariums

Fish nets made of finest netting, 15c.

Great reduction by dozen or gross.

BROADWAY BIRD STORE

P. F. GNADT, Prop.

1632 Broadway Greenhouse 1630 Broadway

BROOKLYN, N. Y.

PRINCELY RECOGNITION

15 West 67th Street, New York, N. Y.

Dear Mr. Brind: June 2, 1916.

I have read with much interest and I am glad to have your books on "DOMESTICATED FISH" with the very valuable information they contain, for I have been interested in Aquaria for a long time, affording as they do the observation of a corner of Nature so little known as to be mysterious and so full of fascinating beauty.

Sincerely yours,
(Sd.) Prince Pierre Troubetzkoy.

NOTE!—Only a limited number of copies of above work remain and may be had by sending \$2.60 direct to the author and publisher

W. L. BRIND, F. Z. S.

(who has now MOVED from Bergenfield) to 449 West 206th Street, New York City, where old friends and new customers will be welcomed (evenings only!) By appointment: Phone, 8413 St. Nicholas.

Direct Importations of Fish, Reptiles, Plants, & MOTION PICTURE FILMS OF FISH, ETC., MADE AND SOLD
\$10 to \$100 each.

THE TERMINAL PET SHOP

PETS OF EVERY DESCRIPTION AND KIND

Manufacturing and Maintenance of Aquariums a Specialty
All Kinds of Cat and Dog Foods and Medicines

Hudson Terminal Building

Concourse, NEW YORK

Broad-tail Telescopes

Correspondence Solicited

GEORGE WILT, 1519 N. 62d Street

PHILADELPHIA

SAMUEL GRAFF

Breeder of Broad-tail Calico Telescopes

\$2.00 up

5013 Hawthorne Street, Frankford
Philadelphia

VIOLET RAY FISH REMEDY

Relieves Constipation, Fungus, Tail Rot, Congestion. Safe and effective. Box of six powders 25c. For sale at Pet Stock Stores, or address

REGENIA CHEMICAL CO., Sta. K, Philadelphia

TEN VARIETIES OF BEAUTIFUL AQUARIUM PLANTS

for \$1.00 Postage Prepaid

J. HENRI WAGNER, 1909 North Capitol
Washington, D. C.

MILWAUKEE TRIPOD CO.

457 Eleventh Street Milwaukee, Wis.

W. C. EVANS, Manager.

Dealer in all kinds of aquarium fishes and Manufacturer and repairer of aquariums. plants. Imported Japanese and Chinese gold-fishes.

FRANKLIN BARRETT

EVERYTHING COMPLETE FOR THE
AQUARIUM, POND AND LAKE

Wyoming Avenue, & C Street, Phila., Pa.

SEND FOR PRICE LISTS

WALTER BELL

Breeder of Broad-tail Telescopes

BLUES BLACKS CALICOS

4324 WYALUSING AVENUE, PHILADELPHIA

Prices Reasonable

"Everything is Fish that comes to the Net of a Naturalist"

Don't paddle in the water with one hand and be blind with both eyes.

In other words, "keep your eyes open" for all nature.

OUR MAGAZINE

The Guide to Nature

WILL HELP YOU

It is edited by Edward F. Bigelow, who fishes in the heavens and earth, as well as the waters under the earth.

Single copy, 10c.

Four months' trial, 25c.

One year, \$1.00.

THE AGASSIZ ASSOCIATION

ArcAdiA

Sound Beach

Connecticut

Aquariums of Artistic Designs

*Strongly Built, Suitable for the Home,
Conservatory, College or Store*

Also all aquarium supplies. We make any size aquarium to order, slate or iron-bottom. Write your wants. Dealers with card write for lowest wholesale prices on globes, food and plants.

WE HAVE FOR SALE

Used little wonder pump, 25 gallon tank, gauge, and regulation valve. Price \$15.00

Address **PIONEER AQUARIUM CO.**

Racine, Wisconsin

HERMAN RABENAU, Aquarist

PERMANENT DISPLAY OF

Aquatic Life and Terraria

must be seen to be appreciated

Visitors Welcome

Plants and Tropical Fish a Specialty

Importations of New Varieties received regularly

1163 Myrtle Avenue, Brooklyn, N. Y.

Near Broadway.

Nippon Goldfish Co.

1749 Buchanan St., San Francisco, Cal.

Importers and Dealers

JAPANESE GOLDFISH

DIRECT FROM BREEDERS IN JAPAN

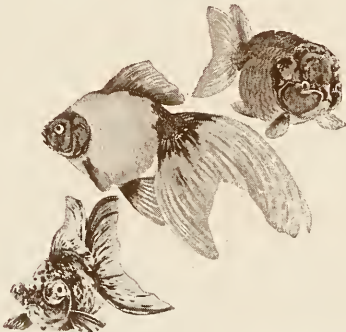

AWARDED GOLD & SILVER MEDALS

Panama-Pacific International Exposition
San Francisco, 1915

All Kinds of AQUARIA & SUPPLIES

Price Lists Furnished to the Trade Only

Harry P. Peters

1210 N. Warnock Street, Phila., Pa

BREEDER AND IMPORTER.

Rare and Fancy Fish

Plants, Snails and Aquarium Supplies
of All Kinds at All Times.

MANUFACTURER OF

Green River Fish Food

10c a Box

Green River Baby Fish Food

15c a Box

A GOOD FISH FOOD is one of the most essential things necessary to keep fish in good health. After the test of years Green River stands out as the best food on the market. It keeps the fish in good color by promoting a healthy, robust growth. It will not sour or cloud the water. Ask your dealer or send for it today.

Young Blue, Black and Calico
Telescopes and Japs \$1.00 per
dozen Up.

Also Veil-tails, \$5 per Dozen Up

Shipping Can, 25c Extra

HARRY P. PETERS

1210 NORTH WARNOCK STREET

PHILADELPHIA

Otto Walter

86 Suydam Street :: Brooklyn, N. Y.

Near Evergreen Avenue L Station

Breeder and Importer of

TROPICAL AND GOLDFISHES

Telescopes Calicos Japs Fan-tails

Dealer in All Varieties of Aquatic Plants

Water Violets My Specialty

All Kinds of Fish Foods

Fresh and Dried Daphnia

AQUARIA, UTENSILS AND SUPPLIES

50,938

November, 1916

10c Copy

Aquatic Life

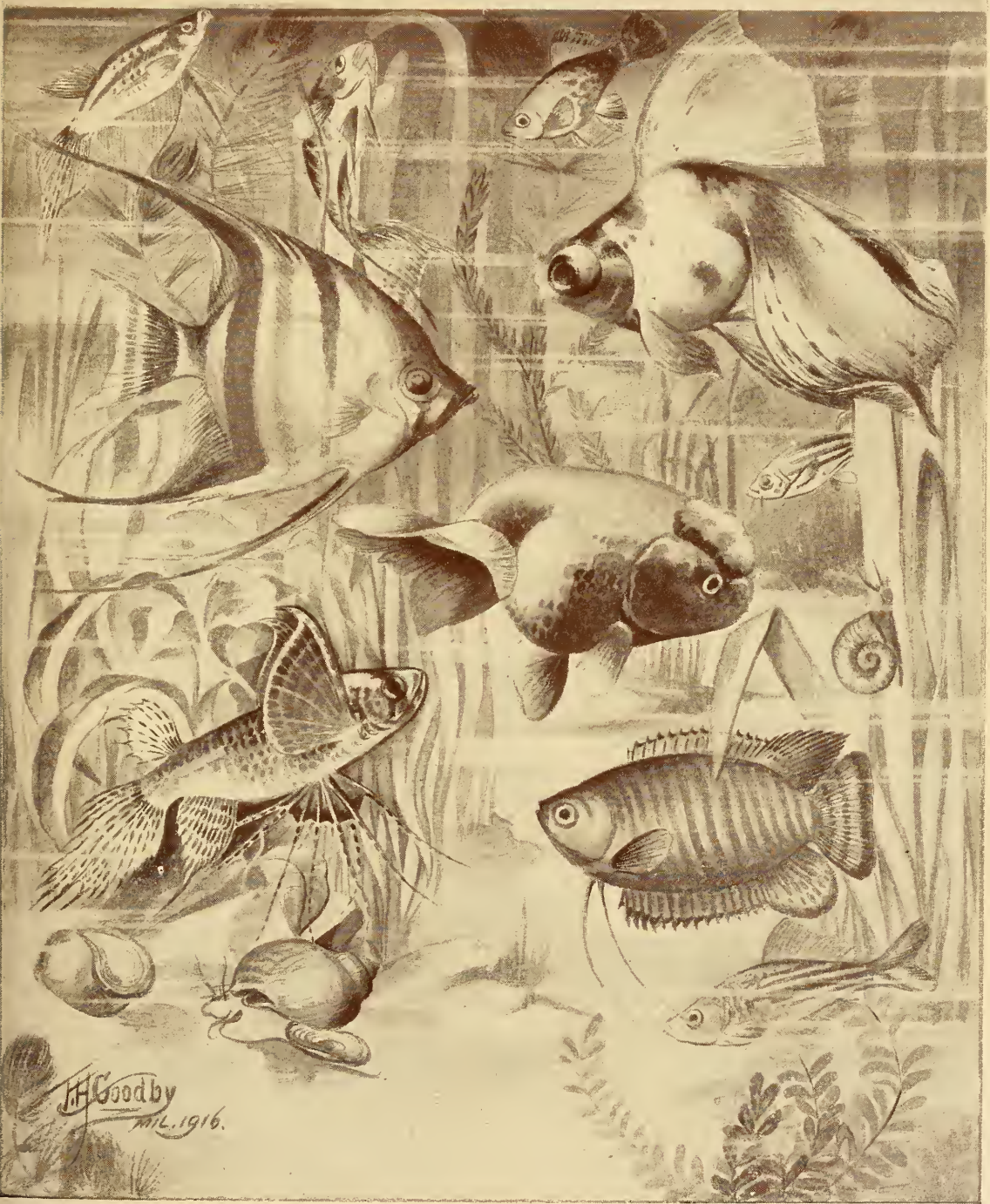

H. Goodby
MIL. 1916.

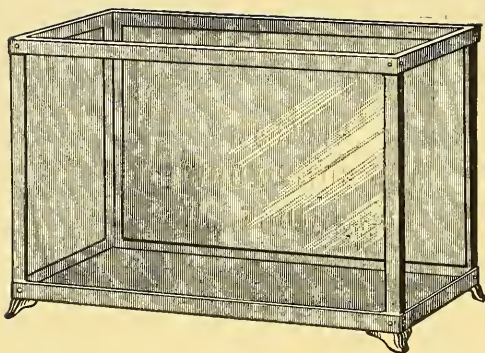

Jacob C. Cassel
915 Arch Street, Philadelphia, Pa

Manufacturer of

AQUARIUMS

Aquarium Ornaments

Floral Terra Cotta, Etc.

Goldfish Fish Globes Fish Food
and all aquarium requisites.
Send for Catalog.

Aquarium Specialty Co. 1873 WASHINGTON AVENUE NEW YORK CITY

MANUFACTURERS OF AQUARIA, FOUNTAINS, TERRARIA, VIVARIA
BREEDERS OF DOMESTICATED FISHES
IMPORTERS OF FOREIGN FISHES
AQUATIC PLANTS, SNAILS AND SUPPLIES

STOCK AQUARIA

Galvanized Metal Frame, Enameled and Gold-Striped, Bottom Slate or Ribbed Glass. Plain. On legs

No. 1.	11"x7"x7"\$1.25	\$1.50
" 2.	14"x9"x9"	1.50 2.00
" 3.	17"x11"x11"	... 2.25	2.75
" 4.	20"x13"x13"	... 3.00	3.75
" 5.	24"x12"x14"	... 4.75	5.50

20% additional for oxidizing.

Solid Brass Frame, on Projecting Slate Bottom or on Legs.

No. 1.	12"x 6"x 8" high,	2 1/2 gal.	\$2.50
" 2.	14"x 8"x10"	5 "	3.25
" 3.	16"x10"x12"	" 9 "	4.75
" 4.	18"x12"x14"	" 14 "	5.75

20% additional for nickel-plating or oxidizing.

Steel Angle Frame, Heavy Plate Glass, Slate Bottom, Flush or Projecting.

No. 3 1/2.	24"x14"x14",	22 gal..	\$8.00
" 4 1/2.	30"x16"x16",	36 "	12.50
" 5 1/2.	36"x18"x18",	54 "	20.00
" 6 1/2.	42"x20"x20",	80 "	35.00
" 7 1/2.	48"x22"x22",	110 "	60.00
" 8 1/2.	54"x24"x24",	145 "	95.00
" 9 1/2.	60"x26"x26",	180 "	135.00

All our aquaria are so constructed that water cannot come into contact with the metal.

All sizes and shapes made to order. We charge only actual cost for packing and cases.

FISH FOODS

	Per Tin box.	Per lb.
Natural Fish Food.....	\$.10	\$.50
Universal Fish Food...	.15	2.00
Ground Dried Shrimp..	.10	1.00
Ground Dried Flies and Insects20	3.00

	Per Tin box.	Per lb.
Ground Dried Daphnia..	\$.20	\$3.00
Whole Ants' Eggs....	.10	1.00
Ground Hulled Ants' Eggs25	4.00
Infusoria Creating Food	.15	2.00

Correspondence Solicited. JOSEPH TAUBLES, Manager. No Catalogues

IF YOU

Are Looking for Something Extra Fine in Broad-Tail Telescopes

Don't Forget W. H. HEIMBACH
Breeder and Importer of FINE FISH
Snails Plants

FISH FOR SALE AT ALL TIMES

413 NORTH 10TH STREET
ALLENTOWN PA.

MECCO GARAGES
Here is a chance to make money
Write for Proposition Give References
— ADDRESS —
M. E. Corrugating Co.
COVINGTON, KENTUCKY

What My Aquarium Means

DAVID H. CUYLER



An Artistic Aquarium Owned by Ernest A. Gill

On a sunny morning, when I enter our living room, there in the bay window is a beautiful bit of nature, gleaming in the sunshine, and just shimmering with activity and life. It arrests the eye with a sense of its usefulness in that it pleases, and pleases plentifully. It speaks to me in a language far more lovely than the human, of everything that is worth while in life. There are the little finny inhabitants seeming to plead for their morning meal; thrusting their snouts above the surface of the water; acting in all ways as if my intention was fully known to them. I find here as simple a demonstration of intelligence as one could wish for. I carry out my part of the arrangement by giving them their daily portion, and then begins the squabble for the minute tidbits and such a flying

about, each one to obtain his rightful share, and maybe a little more; here we have ambition and wholesome rivalry, both very healthful qualities if not abnormally developed as is frequently the case with that specimen of so-called super-intelligence, man.

When the feeding is over and the hunger appeased, comes the seeming endless activity of looking about their limited world to see what is needed; what is new or what requires attention. I do not understand it all, and do not try to. I only know it is good, and that the constant golden fluttering adds to its charm. I am satisfied to allow my little friends to keep secret their reason for doing what I have full faith is useful to them. That I can keep these beautiful little golden friends of mine, and make them happy

and at least nearly natural, is reward enough for any seeming trouble they may prove to be. Just to study to make their little lives as natural as possible is a never-ending delight, and abundantly interesting.

In this work-a-day world, where all of us are prone to make of life an all too serious problem, it behooves every one of us to climb atop of some healthy hobby and ride it for all it is worth. The keeping of aquaria has brightened many a weary hour for me, and countless others; it has pulled me out of the dumps and put me back in balance many a time, just from its simple inspiration and the unending interest it creates in "something different," and, brother, believe me, it is that "something different" that is far the best tonic you can take for all that ails you. And that is why my aquarium means so much to me. I study it profoundly at times; the fishes, the plant life and all of it, and just to see the completeness of it is enough. I say to myself, they are happy because they are natural; they are not trying to be something they are not; they are real and true and thus all good.

To get out into the woods and fields midst the birds and flowers, and to join them in their songs of praise to God; to be simple and true to yourself in nature's own way; that is Life, and Life abundant.

Aquarium Ornamentation

It is unfortunate that in arranging aquaria for public exhibition a recent tendency has been to place therein objects of an entirely foreign nature. Japanese tea gardens perched on broad, flat rocks at the bottom of the tank, and polished sea shells are entirely out of place. They remind one of the china filigree plaques that a few years since we were wont to

"decorate" with mutilated postage stamps and beribbon in gaudy hues. One can't be criticised for liking a tiny tea garden a la Japanese, but use it as that art-loving nation intends—on a tray with sprouted horse radish for foliage. Place it on the shelf under the aquarium, around it, or on a tabourette; don't place it *in* the tank, the Japs don't drink tea under water, except in their submarines. If you admire polished sea shells arranged in geometrical designs, buy a curio cabinet for the purpose.

Placing in an aquarium a foliage plant that is not aquatic, and will neither thrive nor even exist submerged is "nature faking" pure and undiluted. It gives the uninitiated an erroneous impression as to what can be done with an aquarium. Of course, all aquaria as maintained in the household are fakes to a certain degree, showing, as they do, an association of animals and plants never found together in nature. This, however, is due to necessity, and not to deliberation. The geographic aquarium is the only type that follows nature in the sense that all the plants and animals therein are from one and the same locality. If we would interest the general public, let us do so in simple ways as we would teach the child; let us not create wrong impressions of which they must later be disabused.

To oxygenate the water in cans of fishes during shipment, Mr. S. C. Lloyd, of St. Louis Society, advises the use of clean sponges strung across or around the inside of the can above the water-line. The almost constant movement of the conveyance splashes the water upon the sponges, from which it constantly drips, causing continuous aeration. This would seem to be an excellent scheme, but care should be exercised to use clean sponges.

The Use of Sheep Manure

FRANK J. MYERS

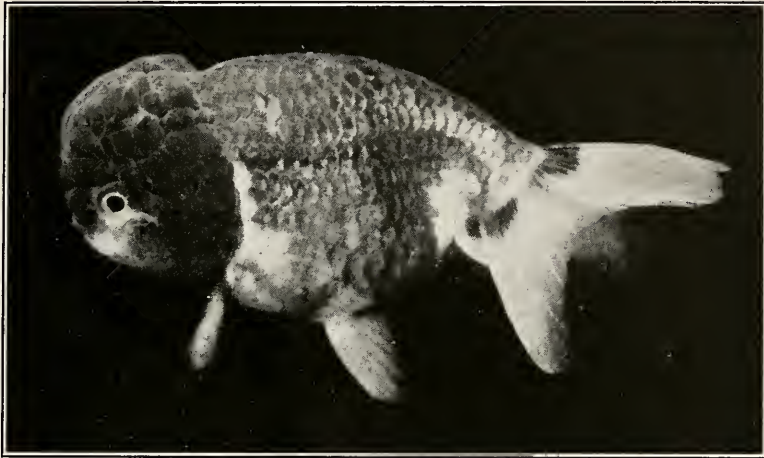

Lionhead Goldfish

Owned and Photographed by F. Schaefer

Having read of the advantages of using sheep manure as a cultivator for aquatic plants in the household aquarium, I decided to do some investigating along this line, as I had always had poor success with *Sagittaria* under certain conditions of light. Some years ago I had an eighty-gallon aquarium built to fit into a square space containing three windows with western exposure. The dimensions of this aquarium were not what they should have been, the depth being too great in proportion to the width; besides, it was subjected to the full glare of the afternoon sun. Plants, with the single exception of *Anacharis*, never grew well in this tank. I tried *Sagittaria* many times with the same result; they never shot off runners, and gradually died out each time.

Accordingly I set up two twelve-gal-

lon aquaria in the following manner: In number one I placed a layer of sand about one-half inch thick; then over this I sprinkled a thin layer of pulverized sheep manure, just enough to cover the sand well, then about an inch and one-half of clean sand over all. I planted this aquarium with *Sagittaria* and placed it in a strong west light, exposed to the afternoon sun, a position identical with that of the unsuccessful large aquarium.

In aquarium number two, I placed two inches of clean sand, planted *Sagittaria* without adding the sheep manure, deciding to feed these plants directly by injecting a saturated solution of the manure among the roots by means of a special syringe consisting of a thin glass tube about fifteen inches long, with a rubber bulb on one end. I filled both aquaria with water at the same time, and

injected the aqueous solution among the roots of plants in number two, three times a week. About the third day, in aquarium number one, I noticed clouds of pulverant, nebulous organizations ascending in thin columns from the sand up to the surface of the water, and there spreading out into cloudlike masses. A microscopical examination proved this to be composed of countless myriads of spores of a certain fungus belonging to the PHYCOMYCETES. Let us now digress a bit for a few words about fungi. The PHYCOMYCETES (Algae-fungi) are so called because they resemble certain Algae more closely than other fungi, and are supposed to have been derived from the Algae, having lost their chlorophyll (sap-green) and power of independent living.

Saprolognia, a genus to which our spores in aquarium number one belong, resemble certain Algae (*Vaucheria* and *Cladophora*) so closely that connection seems plain. The mycelium (working body) is composed of coenocytic hyphae (small thread-like filaments which have no partition walls dividing them into cells), the tips of which become swollen and are cut off by septa (partitions). Within these chambers numerous biciliate zoospores (spores with two cilia, which swim about in the water) are formed, which, after being motile for a short time, settle down and rapidly form new mycelia. This all strongly suggests *Vaucheria* and *Cladophora*. Now the species of *Saprolognia* which appeared in aquarium number one seems to be perfectly harmless to goldfish in good condition. After a few days these countless spores settled down and formed mycelia on the darker portions of the substratum.

In about ten days all the fungus began to disappear very rapidly, the water cleared beautifully, and I noticed young shoots of *Sagittaria* beginning to show

up. They increased with surprising rapidity—the water did not turn green and conditions seemed eminently satisfactory. Then I introduced the fish, which did well from the first. Now, after seven months, in spite of poor conditions, the plants are thriving and multiplying in my eighty-gallon tank. Aquarium number two gave me exactly similar results, only much slower and with more work, as the plants had to be fed continually. I do not hesitate in recommending the sheep manure method to anybody who is troubled with a poor growth of plants, provided the aquarium is set up as I have suggested.

Philadelphia Show

Acting in conjunction, The Aquarium Society of Philadelphia, the Philadelphia Goldfish Fanciers' Society and the Philadelphia Goldfish Exhibitors, held in Horticultural Hall, Fairmount Park, October 7th, 8th and 9th, quite the best exhibit of aquaria and fishes that has ever been shown the local public, which, it must be added, expressed appreciation by attending in crowds. The committee which supervised the staging of the show deserves great credit, and no less the individual exhibitors of which there were too many to mention.

The Black-nosed Dace can with impunity be kept in the same aquarium with fancy goldfish. If the tank is large and well planted there will be little danger of annoyance to the goldfish. There are many fishes of divergent temperament that may be placed together in a large tank that one would not think of associating in a small one. A well fed fish is usually better disposed toward unrelated species than if it is kept hungry. Shunbunkins have been noticed to annoy and nip the fins of broadtail goldfish, but ceased to do it when placed in a larger tank.



The Splashing Salmlet

WALTER LANNOY BRIND, F. Z. S.

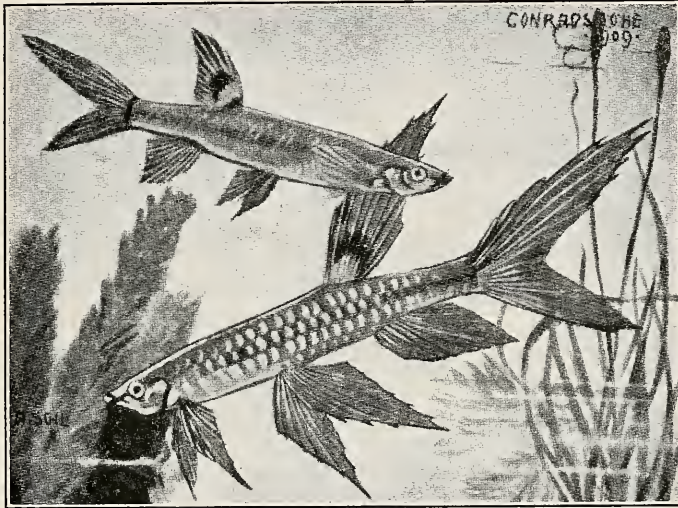

The dainty, active, little Splashing Salmlet, *Pyrrhulina filamentosa*, was first introduced as an aquarium fish by the famous Rossmassler Aquarium Society, of Hamburg, late in 1905, having been imported by them direct from Para, Brazil. The scientific name means "red-finned" and "thread-bearing," and refers to the color and the elongated fins. A remarkable feature is the absence of an adipose or fat-fin (a small rayless fin situated between the dorsal and caudal), which is usually present on fishes of the Characin group, of which our subject is a member. The slender appearance of the fish is very much accentuated by the fins. The color of the body is silvery,

olive on the back and white beneath. The colors are very delicate and pearly—almost translucent. A horizontal black stripe runs from the edge of the gill-cover forward through the eye to the tip of the snout. The dorsal and caudal fins are flame-colored, the inner margin yellowish, the outer fiery red, which gives the fish its attractive appearance. A wild male fish will reach a length of three inches; the female, two and one-half inches. Aquarium-bred specimens seldom attain more than two-thirds the size of the wild fish.

The Salmlet is very active, and especially so during breeding time, which brings us to the most striking character-

istic of the species—its remarkable method of reproduction, and from which it derives the name of Splashing Salmlet. Spawning time having arrived in the aquarium, the male and female, swimming close together, spring out of the water and adhere to the cover-glass or to the side of the tank. Here they stick for as long a period as ten seconds, during which about a dozen eggs are deposited and fertilized, which remain on the glass covered with a drop of water. The operation is repeated ten or twelve times, and after an hour or so about a hundred eggs will have been extruded. A second spawning may occur within a week, but should be discouraged, as it has a weakening effect on the fish.

The male watches the eggs and splashes them with water at intervals of twenty minutes to half an hour, thus keeping them moist. They hatch in thirty-six to forty-eight hours, provided a temperature of about 77 degrees Fahrenheit, has been maintained during incubation. The young hang like comma marks in the drop of water in which they have hatched, and are soon washed down into the aquarium water by the splashing of the male, whereupon they take refuge among the floating plants. Here they feed upon infusoria, of which they must have an abundance, and later they will devour small Daphne and Cyclops.

The proper temperature for adult fish, other than during the breeding period, ranges from 65 degrees to 75 degrees Fahrenheit. An average temperature of 75 degrees, which experienced aquarists favor for most tropical fishes, is about the best to keep them in good condition. Regarding food, *Pyrrhulina* is carnivorous, and particularly fond of Daphne, which should be liberally supplied. Its home should be a sunny, three-gallon, thickly planted and balanced aquarium.

The Salmlet is a native of South America, and has been recorded from Brazil, Surinam, Guiana and the islands off the northeast coast.

Flying Frogs of Java

So many strange stories have been told of the flying frogs of Java that the curious animals have come to be regarded as mythical. However, according to a report of Professor Siedlecki, quoted in the *Journal des Voyages*, these little creatures do exist in actual life.

Professor Siedlecki, who has spent some time at the zoological laboratory at Buitenzorg, Java, has been able to study the flying frogs closely. One of the first conclusions that he reaches is that the name "flying frogs" is inaccurate; for the supposed flight, from which the popular name is derived, is really nothing more than a tremendous leap. "Jumping frog" would describe the animal much more accurately.

The frog has membranes stretched between its fingers and toes. As it jumps, it stretches wide its webs, and with the aid of these parachute-like supports, glides gently to earth again. It is no rare thing for one of these little animals to jump a distance of over six feet. It can readily be imagined how a succession of these gliding leaps creates the impression of sustained flight. The deception is even greater when the frog is jumping from branch to branch or from tree to tree.

Essentially an animal of nocturnal habits, the flying frog spends its days clinging to the leaves of trees. During this time it is torpid and flabby, and breathes with remarkable slowness. Its bluish-green color, blending almost perfectly with the leaves on which it rests, serves as an effective protection against enemies. The flying frog is a striking

Concluded on Page 41

Minute Inhabitants of Aquaria

PERRY BRUCE CLARK

San Francisco Aquarium Society

One of the most interesting phases of the aquarium and its maintenance, to my mind, is that which embraces the observation and study of its minute inhabitants. Any one who possesses an aquarium, an old one used for the propagation of plants is best, or a small amount of stagnant water, will have sufficient material to pursue this study. A good hand lens will suffice for the larger animals, such as the crustaceans, but a low-power microscope is necessary for the observation of the smaller forms. I would suggest that any aquarium society interested in this subject purchase a microscope, and then lend it out to the different members, as I have no doubt that almost all fish and aquarium fanciers will find the observation of these tiny animals a very fascinating pastime.

To approach this subject properly we must begin with the most simple forms of life, and gradually work up to the higher forms. The simple form of life is the single cell. This is a small mass of living matter which is able to multiply and form new cells of the same kind. The main bulk of a cell is made up of a viscid, liquid substance called protoplasm, this is very complex, and is composed chiefly of water, in which is dissolved different salts, and in which is also suspended fine particles of organic matter, such as is taken in for food, waste products of digestion, and other substances which take part in the life activity of the cell. The skin of the cell or cell membrane is formed by a hardening of the protoplasm on the outside of the cell. In the protoplasm is suspended a small body called the nucleus, which contains

the sexual elements, and is the centre of life of the cell. When a cell has reached the maximum of its development a changes begins in the nucleus, the minute chromatin threads or sexual elements (each cell contains both male and female chromatin threads) divide in two parts,

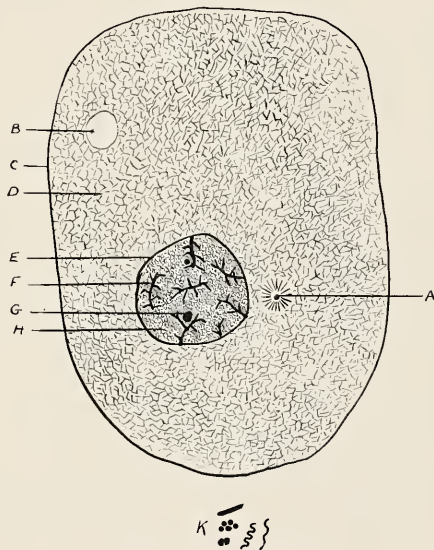

Diagram of a Cell

- A. Centrosome
- B. Contractile vacuole
- C. Cell membrane
- D. Protoplasm
- E. Nuclear membrane
- F. Chromatin threads
- G. Nucleolus
- H. Nuclear plasm
- K. Types of bacteria

a half of each male thread then combines with a corresponding half of a female thread and an equal number of these combined threads place themselves at opposite sides of the nucleus. The nucleus now divides, a half going to each end of the cell, which then becomes constricted in the centre and finally breaks

apart to form two new cells. This is called reproduction by division. This form of reproduction gradually weakens the reproductive powers of the subsequent generations, therefore another form is sometimes resorted to, which is reproduction by conjugation. In this process two cells come together to form one, and after an exchange of sexual elements reproduction goes on as before. This is on the same principle as breeding stock, where new blood must be introduced occasionally, for if it is not done degeneration of the stock takes place. The complete process of cell reproduction has never been completely worked out.

The bacteria, or germs as they are sometimes called, are the simplest form of living cells, as it has not yet been demonstrated that they contain a definite nucleus, as do most cells. It is supposed that the nuclear material is scattered throughout the protoplasm. The reason for bacteria having such a simple organization is that they are all more or less parasitic in nature, and therefore depend largely on other organisms for their supply of nourishment. This parasitism is illustrated by the behavior of the bacteria which prey upon the human body, such as the bacillus of tuberculosis, which lives by eating up the tissue in which it is imbedded. Here the nourishment is already prepared for the germ, and it has merely to absorb it. All parasitic forms of life are found to be in a more or less degenerate state, as the disuse of a function generally always leads to decay, this is well illustrated by the fact that people who do little or no manual work have poorly developed muscles. The bacteria are so low in form that it has not been finally decided whether they are plants or animals. Botanists claim them for plants and zoologists hold that they belong to the Animal Kingdom, as they exhibit some of the characteristics

of both plants and animals, although they favor the plant group a little more than the animal group. In either event they may be taken for the starting point of both the plants and the animals.

To be Continued

The Brooklyn Exhibit

We note with great pleasure that at the big show of the Brooklyn Aquarium Society, September 21st to 24th, Mr. Harry P. Peters, of Philadelphia, was awarded *the* diploma for the "Six Best Young Goldfish Bred by Exhibitor in 1916, Residing Outside of Greater New York." Long since, Harry accumulated such a store of awards that he ceased to find it interesting to paper rooms with the ribbons; hence he has during recent years seldom exhibited for prizes, but when he does he usually "brings home the bacon." Congratulations.

Mr. Franklin Barrett, who takes great pride in his great collection of goldfish and other species, was awarded the diploma for the "Best Display Shown by an Exhibitor Residing Outside of Greater New York." Many of Mr. Barrett's fine goldfish have been illustrated in *AQUATIC LIFE*.

The diploma for the "Best Display of Tropical Fishes" was secured by Mr. Isaac Buchanan. Other diplomas: Miss C. M. Hoppe for "Balanced Aquarium Less than Five Gallons;" Frank B. Jolionnot. "Balanced Aquarium Over Five Gallons;" Charles E. Visel, "Largest and Best Exhibit;" William Tricker, "Best Display of Aquatic and Semi-Aquatic Plants;" Charles E. Visel, "Six Best Young Goldfish Bred by Local Exhibitor."

A few copies of the title page and index to volume one are still available for distribution. A postal card request is sufficient.

The Madagascar Lace Plant

J. LAMBERT, University of Pennsylvania Botanical Garden

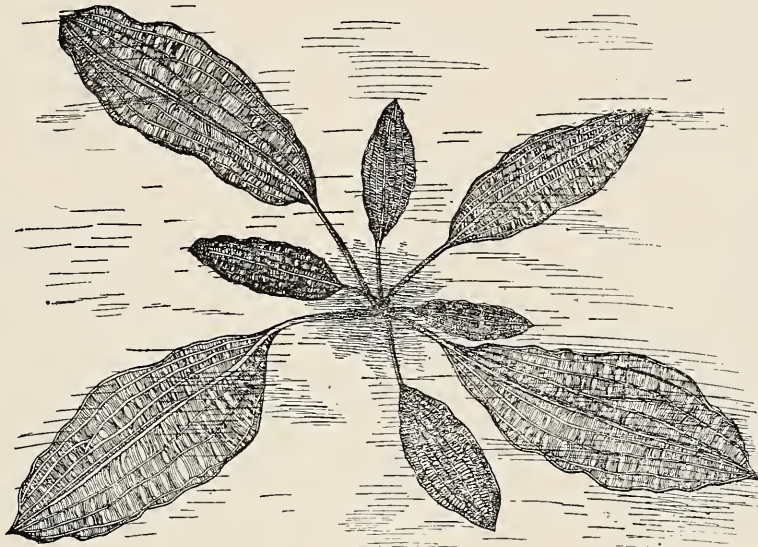

The Lace Plant

Ouvirandra fenestralis

The Lace-leaf Plant, *Ouvirandra fenestralis*, was introduced into cultivation from Madagascar, in 1855, and belongs to the NAIADACEAE, or pondweed family. It is closely related to *Aponogeton*, but differs in having skeletonized leaves. It has been noted that the spaces between the veins sometimes become filled with tissue, causing a partially solid leaf. This feature induced some authors to place it in the genus *Aponogeton*. Such a growth very rarely occurs, and so may be termed a "sport." The plant is a perennial immersed aquatic. The foliage is produced immediately from the crown and forms a rosette of broad, oblong, rich green leaves, which are composed of nerves and cross veins that give it the delicate

lace-like appearance from which the plant obtains its common name. These veins consist chiefly of air-cells that give the leaf its buoyancy; similar in character to the inflated petiole of *Eichhornia*, and the air-pads found on the under surface of the leaves of *Trianca*, *Limnathemum*, etc.

In well-grown specimens the leaves attain a length of eighteen inches, and from two to three inches broad. The numerous small white flowers are borne on two spikes, each about two inches long, united at the base and supported by a stem about twelve inches long, and projected about six inches above the surface of the water. Strong, healthy plants will flower continually throughout the sum-

Aquatic Life

A monthly magazine devoted to the study, care and breeding of native, tropical, gold and fancy fishes, other animals and plants in the household aquarium.

W. A. POYSER Editor
JOSEPH E. BAUSMAN Publisher
542 E. Girard Avenue, Philadelphia

Entered as second-class matter September 2d, 1915, at the Postoffice, Philadelphia, Pa., under Act of March 3d, 1879

Yearly Subscription \$1.00
Foreign Subscriptions 1.35
Single Copy 10 cents

Payments may be made by express money order, draft, postoffice order or registered letter. Foreign remittances should be by international money order.

Advertising rates made known on application.

Aquatic Life is the only magazine in America devoted exclusively to aquatic life, and its value as an advertising medium in this field of nature study is unequaled.

Copyright, 1916, by Joseph E. Bausman.

VOL. 2 NOVEMBER, 1916 NO. 3

mer months. The tubers are edible, and are used as an article of food by the natives of Madagascar. During the dry season the streams in which they grow often become dry, the foliage is killed off, and the tubers alone remain. At the approach of rain the tubers begin to send out new leaves, and in a short time the plant is in full leafage again. Under cultivation they do not need this rest; with the lowering temperature, the absence of the summer sun is all that is necessary during winter.

The Lace Plant is one of the most interesting members of the Vegetable Kingdom, and with the following cultural treatment, it is, as a decorative plant, a real acquisition to the aquarium. In the glass aquarium, for some unaccountable reason, it does not produce large leaves, but sends out small ones of a lighter color that give a charm that no other plant possesses, and as equally effective as large leaves among the other plants

in the aquarium. To produce large, robust specimens a cedar tank is essential. Planted in pots in a mixture of three parts fibrous loam to one part silver sand, and plunged in water six, or not more than nine inches below the surface, they grow to perfection. The temperature of the water should be 65 to 75 degrees Fahrenheit. A light shade is needed; this can be given by placing a tall pot plant by the side of the tank. Care must also be taken to remove from the surface of the soil and leaves the green algae that collects, otherwise failure is sure to ensue. Potting should be done as soon as the new leaves are about two inches long, and never when the plant is in a dormant condition. Propagation is also effected by seeds sown an eighth inch deep in small pots of soil and placed in water. The temperature should be about 75 degrees Fahrenheit. They are more readily propagated by dividing the crowns.

There is another species of *Ouvirandra* with pink flowers, but *O. fenestralis* is considered the best as a decorative subject.—*Reprinted from Aquarium Notes and News.*

Wm. E. Walp

The fraternity of goldfish fanciers has sustained a severe loss in the death of the well-known Philadelphia fancier, William E. Walp, who died after a short illness on October 1st. Gifted with a sunny disposition, he was exceedingly popular. Beginning many years ago with goldfish breeding as a hobby, he developed it into a remunerative vocation and soon became known from coast to coast as a breeder of fine fishes.

Mrs. Walp, who has been equally active and interested in the fish, will continue to maintain the hatchery, and will welcome the patronage of the fancy.

NOTES & NEWS



Old Mother Hubbard had so many children she didn't know what to do—so the jingle tells us. Mr. and Mrs. Taubles had so many water hyacinths—but they *know* what to do! Captions for illustrations are sometimes inspired, but for the above our “gray matter” has failed to respond, so we let it go without, knowing that the many aquarists who have not met these well-known fanciers will be glad to greet them through the medium of the camera, regardless of what we may say about the photograph. The pond shown is interesting in several particulars. It is large, but not to a point of inconvenience; further, it is shallow, making inspection of its contents easy. Those who are considering the construction of a concrete pool will do well to give thought to these details.

The regular meeting of the Philadelphia Goldfish Fanciers' Society was held in Saull's Hall, 802-4 West Girard avenue, Wednesday evening, October 18th. Broadtail Telescopes, scaled and transparently scaled, competed for two silver cups and ribbons. Messrs. R. L. Harding, James Kerr and William H. Norton, acting as judges, made awards as follows:

Scaled Class—Cup to Mr. William Hartman; blue ribbon, Charles Hinkle; red ribbon, William J. Christy; yellow ribbon, Howard E. Demuth.

Transparently Scaled Class—Cup to Fred Schaefer; blue ribbon, Joseph E. Bausman; red ribbon, Fred Schaefer; yellow ribbon, Joseph E. Bausman.

The following fanciers were proposed and elected to membership; Dr. Louis W. Rehbein, Messrs. John Heffener,

Harry H. Mills, William D. Sargent, Edgar S. Colden, William J. Hodges, James Boyd, George Jann and Louis J. Staunton.

The next meeting, Wednesday evening, November 15th, will be devoted to a competition for broadtail Japs, scaled and transparently scaled, more than one year old. A cup and three ribbons will be awarded in each class.—*Fred Richardson, Secretary.*

Mr. James E. Benedict, Jr., has become secretary of the Washington Aquarium Society, succeeding Mr. J. Henri Wagner, who resigned. Mr. Benedict, who is a son of Dr. J. E. Benedict, of the Smithsonian Institution, is thoroughly familiar with the local vertebrate fauna, and as secretary should be an exceptionally helpful worker.

Los Angeles News

When a member of the Chicago Fish Fanciers' Club I had quite a collection of domestic and exotic fishes, a number of tanks, and some of them very well balanced. Out here it is very difficult to get anything whatsoever, and I have a hard time to get an aquarium even fairly established. The water contains so much lime and other mineral substances that the plants fail to thrive. It seems difficult to place the tanks in the proper situation, as the light here is so intense. Direct sunlight, even for but a couple of hours during early morning or afternoon, promotes a tremendous growth of algae, which in a week or so will completely fill the aquarium and make the water resemble a mass of green jelly. Some of this algae not only grows on the glass, but attacks the plants, retards their growth, and causes decay.

To get fish here is well-nigh impossible, that is, other than goldfish, in which I am little interested. About four months ago

I was able to secure a pair of *Gambusia holbrooki*, and now have about fifteen youngsters of various ages living happily in an all-glass aquarium. I wish I could get a few pairs of *Hemichromis bimaculata* and *Cichlasoma nigrofasciatum*. I am especially fond of *Hemichromis*. I think it is the most beautiful and interesting of our aquarium fishes, and very easily bred in captivity.

Several of the moving picture stars out here are fish fanciers, including Bill Far-

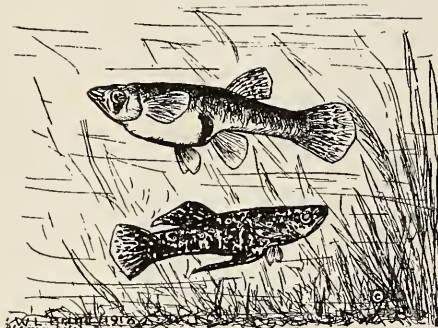

Gambusia affinis holbrooki

(From "Domesticated Fish" by courtesy of Author, W. L. Brind)

nun, Francis X. Bushman and Carter De Haven. They talk fish every time we meet.—*G. P. von Harleman* in a letter to the editor.

Young fishes vary in rapidity of growth; some will be vigorous and grow quickly, while others will be puny. Judgment must be used in caring for the tardy ones. They naturally suffer in competition in the same tank with their more husky brethren. It is advisable to separate the fishes according to size as closely as available tanks will permit. Perhaps it will be just as well to do away with the weaklings.

As one of the steps in a local campaign to insure the humane treatment and proper care of goldfish and other aquatic animals, Mr. J. Henri Wagner,

of Washington, D. C., recently gave a lecture on "The Balanced Aquarium or House Pond," before the teachers and pupils of the Seaton School. He illustrated his talk with an aquarium which was complete, and with another which he equipped before his audience.

It is to be regretted that political influence in St. Louis is being exerted in opposition to the establishment of a public aquarium. The big business house of Messrs. Salomon and Schuchat, however, announces that it will equip and maintain in its store an extensive permanent exhibition that will cost some thousands of dollars to maintain. Let us hope that the generosity of this firm will serve to impress upon the politicians that the people cannot always be led, and that the time is approaching when an adequate public and permanent exhibition will be demanded in no uncertain terms. In educational value a public and permanent exhibition of aquatic life follows close after the school house.

No Time Lost

Under his feet no tall grass grew, some speed was Willie's scoot; right out of swimming togs into his rah! rah! football suit.

SHELLS OF LAND AND WATER. By Frank Collins, of the Chicago Academy of Natural Science. What is the life-history of a snail? From this interesting volume you will learn how they live, where they live, and how to collect them. Written in a popular style, the chapters take one on numerous outings with a college professor and his class. Eight full-page plates, showing 82 species in their natural colors, and numerous half-tone and line engravings, adequately supplement the text. Octavo, cloth binding,

price \$2.50. Add parcel postage on three pounds.

The crayfish is said to live 20 years; the sea anemone 50 years; the pike and carp 100 years.



I'll just wait till the tide goes out.—
London Opinion.

Concluded from Page 34

example of protective coloration, for its hues vary with the time and the brightness of the day. In the sunshine of the early morning the frog is a bright blue-green; later, as the day advances, its color becomes a deeper and darker green, and toward night almost black.

It is not till the sun has set that the flying frog begins to shake off its torpor. Then it rouses to the business of the day—or of the night—and sallies forth on its hunt for insects. It shows a great preference for large butterflies, and, aided by its remarkable leaping powers, is very successful in capturing them.

The strange little animals do not confine their activities to the earth and trees, but are equally at home in the water. There the webs that serve them as wings on land become useful as oars.

Aquarium Societies

Brooklyn Society Incorporated

Meets second and fourth
Tuesday, Prospect Branch,
Brooklyn Public Library.

President—JOSEPH FROELICH11 St. Francis Place
Corresponding Secretary—CARLTON H. CHAPIN39 Kenilworth Place
Recording Secretary—WILLIAM D. SARGENT129 Columbia Heights
Treasurer—GEORGE W. POST52 Herkimer Street

American Federation of Goldfish Fanciers

Meets second and fourth
Monday, in Johnston Building,
Brooklyn.

President—MATTHEW BOWMAN427 Forty-fourth Street
Vice-President—JAMES J. HOARE752 Monroe Street
Treasurer—JOHN DEBUS313 South Fourth Street
Secretary—MRS. M. BOMAN427 Forty-fourth Street

Aquarium Society of Philadelphia

Meets fourth Wednesday,
1414 Arch street.

President—H. R. LIPPINCOTTCollingswood, N. J.
Vice-President—H. S. FULLERTON135 West Wyoming Avenue
Secretary—WALTER LEE ROSENBERGERP. O. Box 66, Philadelphia
Treasurer—R. L. HARDING6008 Master Street

Philadelphia Goldfish Fanciers

Meets third Wednesday,
Saul's Hall, 804 Girard avenue.

President—GEORGE B. SMITH2013 East Cumberland Street
Vice-President—HARRY P. PETERS1210 N. Warnock Street
Secretary—FRED. RICHARDSON3841 N. Marshall Street
Treasurer—GEORGE W. PRICE2145 South Lee Street

The Aquarium Society

Meets second Thursday, Ger-
man-American School, Sher-
man avenue, Jersey City;
fourth Friday, American Muse-
um of Natural History,
New York City.

President—RICHARD DORNUpper Montclair, N. J.
Vice-President—DR. E. BADEGlenhead, L. I., N. Y.
Secretary—HOWLAND WOOD156th Street and Broadway
Assistant Secretary—CLARENCE B. RUCH615 West 155th Street
Treasurer—J. P. LOWELL146 Grace Street, Jersey City, N. J.

Chicago Aquarium Society Incorporated

Meets second and fourth
Thursday in Keedy Studio, 19
E. Cedar street.

President—S. H. LINDAHL6733 Ridgland Avenue
Vice-President—H. W. KEEDY19 East Cedar Street
Secretary—FRED. G. ORSINGER123 South Oakley Blvd.
Treasurer—G. J. BORGSTROM, JR.1408 North Kedzie Avenue

Milwaukee Society

Meets first Tuesday at 8
P. M. in Trustees' room of
the Public Museum.

President—LIBORIUS SEMMANN752½ Thirty-eighth Street
Vice-President—E. F. KIECKHEFER99 Seventeenth Street
Corresponding Secretary—REV. G. KELLER RUBRECHT999 Island Avenue
Recording Secretary—REV. PAUL ROTH2602 Prairie Street
Treasurer—GEORGE J. C. STEFFENS950 First Street

Reading Society

Meets first and third Tues-
day, 104 N. Ninth street.

President—JOHN KERSHNER223 South Third Street
Vice-President—W. H. HMMERSHITZ220 Pier Street
Secretary and Treasurer—S. O. MELLERT120 West Windsor Street

Lancaster Society

Meets at Wheatland Hotel,
Lancaster, Pa., first Wednes-
day.

President—HIRAM PEOPLESNew Providence Pa.
Vice-President—H. H. MYERS431 West Orange Street
Secretary and Treasurer—W. M. HAWMAN250 East Ross Street

Minneapolis Society

President—F. L. TAPPAN92 South Seventh Street
Treasurer—J. W. FRANZENMuseum, Public Library
Secretary—MRS. ANNA ESSENE3421 South Longfellow Avenue

Pittsburgh Society

Meets second Wednesday,
8148 Jenkins' Arcade.

President—DR. O. T. CRUICKSHANK8148 Jenkins' Arcade
Vice-President—A. A. ALLEN221 Belthoover Avenue
Treasurer—C. J. MERTEN24 Chalfont Street
Secretary—E. W. HARPER424 Jaconda Street

National Society St. Louis

Meets second and fourth
Monday, 502 Commercial Bldg.

President—S. CHICHESTER LLOYD4442 Morganford Road
Vice-President—A. H. THURSBY3005 Osage Street
Treasurer—G. H. FOX5041-A Alabama Avenue
Secretary—CHARLES A. KLOEPPER4412 Natural Bridge Road

Washington Society

Honorary President—DR. HUGH M. SMITHU. S. Fisheries Bureau
Active President—DR. R. W. SHUFELDT3356 Eighteenth Street, N. W.
Vice-President—LOUIS W. BAUER722 K Street, N. E.
Vice-President—MRS. L. HELEN FOWLERKenilworth, D. C.
Secretary—JAMES E. BENEDICT945 Pennsylvania Avenue
Treasurer—EDWARD S. SCHMID712 Twelfth Street, N. W.

San Francisco Society

President—F. S. CURTIS760 Church Street
Vice-President—W. J. RICHARDS449 O'Farrell Street
Secretary and Treasurer—HARRY A. KNIGHT60 California Street

Cosser County Society

Meets first and third Friday
401 Plane Street, Newark,
N. J.

President—LOTHAIR SMITHEast Orange, N. J.
Vice-President—DR. WILLIAM BACHMANN247 Littleton Avenue
Secretary—GEORGE HOFERNIG465 Clinton Avenue
Treasurer—MAX G. HAMMERSCHLAG35 Nelson Place

STATEMENT OF THE OWNERSHIP, MANAGEMENT, CIRCULATION, ETC., REQUIRED BY THE ACT OF CONGRESS OF AUGUST 24, 1912, OF AQUATIC LIFE, PUBLISHED MONTHLY AT PHILADELPHIA, PENNSYLVANIA, FOR OCTOBER 1ST, 1916:

State of Pennsylvania,
County of Philadelphia, ss:

Before me, a notary public in and for the State and County aforesaid, personally appeared W. A. Poyser, who, having been duly sworn according to law, deposes and says that he is the editor of AQUATIC LIFE, and that the following is, to the best of his knowledge and belief, a true statement of the ownership, management (and if a daily paper, the circulation), etc., of the aforesaid publication for the date shown in the above caption, required by the Act of August 24, 1912, embodied in Section 443, Postal Laws and Regulations, to wit:

That the names and addresses of the publisher, editor, managing editor, and business managers are:

Publisher—Joseph E. Bausman, 542 East Girard avenue, Philadelphia, Pa.

Editor—W. A. Poyser, Wood Lynne, New Jersey.

Managing Editor—None.

Business Managers—None.

That the owners are: (Give names and addresses of individual owners, or, if a corporation, give its name and the names and addresses of stockholders owning or holding 1 per cent. or more of the total amount of stock.)

Owner—Joseph E. Bausman, 542 East Girard avenue, Philadelphia, Pa.

That the known bondholders, mortgagees, and other security holders owning or holding 1 per cent. or more of the total amount of bonds, mortgages or other securities are: *None*.

W. A. POYSER, *Editor*.

Sworn to and subscribed before me this 2d day of October, 1916.

(Seal) A. D. DEWEES.

(My commission expires at the end of the next session of the Legislature.)

The Nature Study Review

OFFICIAL JOURNAL
AMERICAN NATURE-STUDY
SOCIETY

The numbers for the coming school year will be filled with special articles from practical teachers dealing with actual works, methods and suggestions for school gardening, elementary agriculture and nature-study.

DO NOT MISS ANY OF THEM

\$1.00 per year. 15c per copy.

SUBSCRIBE NOW

Add for Canadian Postage, 10c. Foreign
Postage, 20c. With Aquatic Life One
Year, \$1.50.

Address All Orders to

The Nature Study Review

ITHACA, N. Y.

CALICO TELESCOPE YOUNG

\$5.00 per Dozen

TRY I. X. L. BABY FISH FOOD

WILLIAM E. WALP

1309 North 55th Street, Philadelphia

Thomas Ayling

FINE BROAD-TAIL TELESCOPES

Some Nice Young and Breeders at Reasonable Prices

845 East Ontario Street :: Philadelphia

AQUARIUM STOCK CO.

150 Chambers Street, New York City

Aquarium Specialists

GOLDFISH, FOODS, PLANTS, SNAILS, ETC.

Combination Natural Fish Food - - Sample Can 10c

Imported Shrimp Fish Food - - - Sample Can 15c

Imported Wafer Fish Food - Large Sample Box 10c

Special Prices on Quantity Lots Cash With Order

Catalogue Sent Upon Request

ORDERS AMOUNTING \$2 DELIVERED POSTPAID

Mail Orders Promptly Attended To

Aquatic Life

Aquatic Life. Volume One. America's aquarian naturalists have collaborated to make "Aquatic Life" a practical cyclopaedia for the aquarist. The first volume, 166 pages, is complete. Every essential phase of this fascinating branch of nature-study is treated; special articles, splendidly illustrated, cover goldfish breeding, native and exotic species; the care of the aquarium, and the general subject. The illustrations, more than one hundred, some in color, include the finest that have ever been published of the various goldfish breeds. "Aquatic Life" is conceded the best illustrated aquarists' magazine in the world. The volume costs two dollars, postage prepaid.

Address **Aquatic Life**

(Book Department)

542 East Girard Avenue, Philadelphia

EDWARD S. SCHMID

Emporium of Pets

ALL KINDS OF GOLDFISHES AND AQUATIC PLANTS AND WATER LILIES

712 Twelfth Street, N. W., Washington, D. C.

Taxidermy

Send for Catalog

DRIED SHRIMP - (Ground 75c per Pound)

Postpaid Special Price on Quantity Lots

My Natural Fish Food Sample can 15c Per Pound \$1.00

CANADIAN BIRD STORE

2139 W. Van Buren Street

Chicago, Ill.

Aug. C. Freitag & Son Aquarists

Mollienisia latipinna; Domesticated

(Not Sold in Wild State)

Chamelions, Turtles, Alligators, Etc.

PRICES QUOTED CORRESPONDENCE SOLICITED

223 - 225 BOURBON STREET

NEW ORLEANS

"AQUARIA FISH"

A Practical work on care and breeding of fish in the Aquarium, Greenhouse and out-door Ponds. Finely illustrated.

Everyone interested in keeping fish should send for a copy of this book, price, \$1.

FOR SALE—A limited number of Red Squirrels, Chipmunks or Striped Ground Squirrels, Cotton-tail Rabbits and White Bellied Deer Mouse.

F. L. TAPPAN

92 S. 7th Street, Minneapolis, Minn.

R. PEGLOW

Dealer and Breeder of **Fancy Goldfish**

Broad-tail Telescopes My Specialty

All Kinds of Aquaria and Supplies

557 WOODWARD, AVE., BROOKLYN, N. Y.

USE REGENIA AQUARIUM SALTS

To replace natural salts in waters as absorbed by fish and snails
6 POWDERS IN BOX, 25 CENTS

Regenia Chemical Co., Sta. K, Philadelphia

ENCHYTRAE

The Secret of Successful Breeding of Tropical Fishes and the Ideal Live Fish Food.

Portion, 50c (cash or money order) with Instructions how to breed them

CHARLES E. JENNE

109 22nd Street

West New York, N. J.



Analysis from Washington show that sun-dried foods contain a larger percentage of nourishment than cooked foods. YOGI is sun-dried and every grain is all nourishing food. If you want the best for your money feed YOGI. You'll say its the best you've had.

Robert J. Schaeffer

1818 Frankford Ave., Phila. Sample 12c

ONCE YOU TRY, YOU ALWAYS BUY
Gnadt's Perfect Fish Food, 10c a Box

Pulverized or Whole Shrimp, 75c lb.

BREEDER OF FANCY GOLD AND TROPICAL FISHES

Manufacturer of all kinds of aquariums

Fish nets made of finest netting, 15c.

Great reduction by dozen or gross.

BROADWAY BIRD STORE

P. F. GNADT, Prop.

1632 Broadway Greenhouse 1630 Broadway

BROOKLYN, N. Y.

FRANKLIN BARRETT

EVERYTHING COMPLETE FOR THE
AQUARIUM, POND AND LAKE

Wyoming Avenue, & C Street, Phila., Pa.
SEND FOR PRICE LISTS

WALTER BELL

Breeder of **Broad-tail Telescopes**
BLUES BLACKS CALICOS
4324 WYALUSING AVENUE, PHILADELPHIA
Prices Reasonable

TEN VARIETIES OF BEAUTIFUL AQUARIUM PLANTS

for \$1.00 Postage Prepaid

J. HENRI WAGNER, 1909 North Capitol
Washington, D. C.

MILWAUKEE TRIPOD CO.

457 Eleventh Street Milwaukee, Wis.
W. C. EVANS, Manager.

Dealer in all kinds of aquarium fishes and
Manufacturer and repairer of aquariums.
plants. Imported Japanese and Chinese gold-
fishes.

"Everything is Fish that comes to the Net of a Naturalist"

Don't paddle in the water with one
hand and be blind with both eyes.

In other words, "keep your eyes open"
for all nature.

OUR MAGAZINE

The Guide to Nature

WILL HELP YOU

It is edited by Edward F. Bigelow,
who fishes in the heavens and earth, as
well as the waters under the earth.

Single copy, 10c.

Four months' trial, 25c.

One year, \$1.00.

THE AGASSIZ ASSOCIATION

ArcAdiA

Sound Beach

Connecticut

PHENOMENAL SUCCESS

Has Crowned My Efforts in
BREEDING TROPICAL FISHES
This Season

This means that the most desirable
fishes will be available to Fanciers in
the Spring, for which orders may now
be booked. Now is the time to read
up and get reliably posted on this sub-
ject.

"DOMESTICATED FISH" tells
you in plain simple English just how
to succeed with your fish as I have
done.

Price is \$2.60, postpaid, obtainable
direct from myself, the Author and
Publisher. Order today!

DIRECT IMPORTATIONS from
Venezuela, Java, Celebes, India, etc.,
are shortly expected by me and will
introduce many **QUITE NEW**
SPECIES.

Progressive Aquarists, come to me
for your stock.

W. L. BRIND, F. Z. S.

449 W. 206th Street New York City

Broad-tail Telescopes

Correspondence Solicited

GEORGE WILT, 1519 N. 62d Street

PHILADELPHIA

THE BRUCE FISHERIES

Breeder, Importer, Wholesale & Retail Dealer in

All Kinds of Goldfish

Comets a Specialty

ELGIN K. BRUCE, THORNBURG, IA.

THE TERMINAL PET SHOP

PETS OF EVERY DESCRIPTION AND KIND

Manufacturing and Maintenance of Aquariums a Specialty

All Kinds of Cat and Dog Foods and Medicines

HUDSON TERMINAL BUILDING

Concourse, New York

VIOLET RAY FISH REMEDY

Relieves Constipation, Fungus, Tail Rot, Con-
gestion. Safe and effective. **Box of six pow-
ders 25c.** For sale at Pet Stock Stores, or
address

REGENIA CHEMICAL CO., Sta. K, Philadelphia

Aquariums of Artistic Designs

*Strongly Built, Suitable for the Home,
Conservatory, College or Store*

Also all aquarium supplies. We make any size aquarium to order, slate or iron-bottom. Write your wants. Dealers with card write for lowest wholesale prices on globes, food and plants.

WE HAVE FOR SALE

Used little wonder pump, 25 gallon tank, gauge, and regulation valve. Price \$15.00

Address PIONEER AQUARIUM CO.
Racine, Wisconsin

HERMAN RABENAU, Aquarist

PERMANENT DISPLAY OF

Aquatic Life and Terraria

must be seen to be appreciated

Visitors Welcome

Plants and Tropical Fish a Specialty

Importations of New Varieties received
regularly

1163 Myrtle Avenue, Brooklyn, N. Y.
Near Broadway.

Nippon Goldfish Co.

1749 Buchanan Street, San Francisco, Cal.

Importers ; and ; Dealers

JAPANESE GOLDFISH

DIRECT FROM BREEDERS IN JAPAN



AWARDED GOLD & SILVER MEDALS

Panama-Pacific International Exposition
San Francisco, 1915

ALL KINDS OF AQUARIA AND SUPPLIES

Price Lists Furnished to the Trade Only

HARRY P. PETERS

1210 N. Warnock Street, Philadelphia, Pa

BREEDER AND IMPORTER

Rare and Fancy Fish

Plants of every variety, Snails and Aquarium Supplies of all kinds at all times.

MANUFACTURER OF

Green River Fish Food

10c a Box

Green River Baby Fish Food

15c a Box

A GOOD FISH FOOD is one of the most essential things necessary to keep fish in good health. After the test of years Green River stands out as the best food on the market. It keeps the fish in good color by promoting a healthy, robust growth. It will not sour or cloud the water. Ask your dealer or send for it today.

Young Blue, Black and Calico
Telescopes and Japs \$1.00 per
dozen Up.

Also Veil-tails, \$5 per Dozen Up

Shipping Can, 25c Extra

HARRY P. PETERS

1210 NORTH WARNOCK STREET
PHILADELPHIA

Otto Walter

86 Suydam Street :: Brooklyn, N. Y.

Near Evergreen Avenue L Station

Breeder and Importer of

TROPICAL AND GOLDFISHES

Telescopes Calicos Japs Fan-tails

Dealer in All Varieties of Aquatic Plants

All Kinds of Fish Foods

Fresh and Dried Daphnia

AQUARIA, UTENSILS AND SUPPLIES

December, 1916

10c a Copy

Aquatic Life



J.H. Goodby
MIL. 1916.

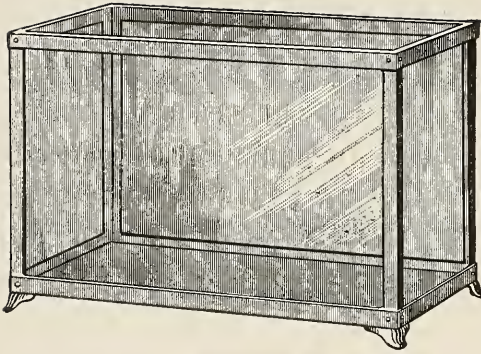

Jacob C. Cassel

915 Arch Street, Philadelphia, Pa

Manufacturer of

AQUARIUMS

Aquarium Ornaments

Floral Terra Cotta, Etc.

Goldfish

Fish Globes

Fish Food

and all aquarium requisites.

Send for Catalog.

Aquarium Specialty Co. 1873 WASHINGTON AVENUE NEW YORK CITY

MANUFACTURERS OF AQUARIA, FOUNTAINS, TERRARIA, VIVARIA

BREEDERS OF DOMESTICATED FISHES

IMPORTERS OF FOREIGN FISHES

AQUATIC PLANTS, SNAILS AND SUPPLIES

STOCK AQUARIA

Galvanized Metal Frame, Enameled and Gold-Striped, Bottom Slate or Ribbed Glass.

	Plain.	On legs
No. 1. 11"x7"x7"	\$1.25	\$1.50
" 2. 14"x9"x9"	1.50	2.00
" 3. 17"x11"x11"	2.25	2.75
" 4. 20"x13"x13"	3.00	3.75
" 5. 24"x12"x14"	4.75	5.50

20% additional for oxidizing.

Solid Brass Frame, on Projecting Slate Bottom or on Legs.

No. 1. 12"x 6"x 8" high, 2½ gal.	\$2.50
" 2. 14"x 8"x10" " 5 "	3.25
" 3. 16"x10"x12" " 9 "	4.75
" 4. 18"x12"x14" " 14 "	5.75

20% additional for nickel-plating or oxidizing.

Steel Angle Frame, Heavy Plate Glass, Slate Bottom, Flush or Projecting.

No. 3½. 24"x14"x14", 22 gal..	\$8.00
" 4½. 30"x16"x16", 36 " ..	12.50
" 5½. 36"x18"x18", 54 " ..	20.00
" 6½. 42"x20"x20", 80 " ..	35.00
" 7½. 48"x22"x22", 110 " ..	60.00
" 8½. 54"x24"x24", 145 " ..	95.00
" 9½. 60"x26"x26", 180 " ..	135.00

All our aquaria are so constructed that water cannot come into contact with the metal.

All sizes and shapes made to order. We charge only actual cost for packing and cases.

FISH FOODS

	Per Tin box.	Per lb.
Natural Fish Food.10	.50
Universal Fish Food.15	2.00
Ground Dried Shrimp.10	1.00
Ground Dried Flies and Insects20	3.00

	Per Tin box.	Per lb.
Ground Dried Daphnia.20	\$3.00
Whole Ants' Eggs.10	1.00
Ground Hulled Ants' Eggs25	4.00
Infusoria Creating Food15	2.00

Correspondence Solicited. JOSEPH TAUBLES, Manager. No Catalogues

IF YOU

Are Looking for Something Extra Fine in Broad-Tail Telescopes

Don't Forget W. H. HEIMBACH

Breeder and Importer of FINE FISH

Snails Plants

FISH FOR SALE AT ALL TIMES

413 NORTH 10TH STREET
ALLENTOWN PA.

MECCO GARAGES

Here is a chance to make money

Write for Proposition Give References

— ADDRESS —

M. E. Corrugating Co.
COVINGTON, KENTUCKY





Enchytrae: A Fish Food

C. J. HEEDE

The small, white worms called "*Enchytrae*," are related to the common earthworm, which was described in the September number of *AQUATIC LIFE*, but, unlike it, obtain their food in concentrated form. The name is from the Greek and means "in pots," these worms occasionally appearing in flower pots. They are now much used as a food for aquarium fishes, especially during the months of winter, when *Daphne* is scarce or unobtainable. They make an ideal ration, and fortunately are very easily raised. This is best accomplished in a wooden box, six to eight inches deep, filled with well-mixed leaf-mold and sawdust (not from resinous wood). Grounds from the coffee pot may be added to make the mixture more porous. The compost thus made should be a little moist, *not wet*, and the box provided with a cover to prevent it becoming dry. If it is too wet or too dry the worms will perish. They breathe through their skin, hence reasonable moisture and ventilation is necessary, the latter being afforded by boring a few holes through the sides of the box above the earth. Light is not necessary, but the box should be placed where it will have an average temperature of about 60 degrees, Fahrenheit.

A supply of the worms should now be placed in the box, and will be found to multiply rapidly. They are double-sexed and produce their eggs in cocoons, which, however, are fertilized by the sperm of another worm inserted or placed on the one now bearing the co-

coon. The cocoon is formed around the body, moves forward, and on the way absorbs the fertilizing sperms. After it passes over the head both ends close. The eggs hatch within the cocoon, the young remaining therein for a short time feeding upon the inner parts, after which they creep out and shift for themselves.

The food of the worms, which consists of boiled potatoes or white bread moistened with milk, boiled oatmeal, or remnants from the pantry, such as pancakes or liver pudding, is placed in grooves or holes in the earth one inch deep. With this method the food supply can be examined at any time, and only replenished when exhausted. Too much food will sour and contaminate the soil and cause failure.

When worms are desired for the fishes a slice of white bread, moistened with milk, should be laid upon the earth. Soon after the worms will usually be found beneath it in clumps. When dropped into the aquarium they may live for days if they manage to escape the fishes. Some aquarists have asserted that it is safer to cut the worms into pieces, especially the larger ones, as they may otherwise find lodging in the gills of the fishes with sad results. Such an occurrence is rather exceptional, and rarely will any harm result from feeding them whole.

When collecting a supply from the breeding box the minute cocoons should not be disturbed, as it is upon these that the future supply depends.



Fig. 1. Male Water Newt (*Diemyctylus viridescens*) Nearly Natural Size



Fig. 2. Male and Female Water Newts. Male Clutching Female About the Neck With Hind Limbs

Photographs From Life by the Author



Notes on the Water Newt

DR. R. W. SHUFELDT, C. M. Z. S.

At different times for many years past I have kept in aquaria specimens of our common Water Newt (*Diemystylus viridescens* of Rafinesque, Figs. 1 and 2), and closely studied their habits under such conditions. Upon comparing my notes with various accounts I have read of this batrachian, I find that I have observed not a few habits not usually, if ever, recorded in the books; these will be briefly set forth in the present article.

This beautiful little newt makes a very interesting aquarium pet, and if regularly fed soon comes to recognize you as you approach the aquarium at feeding time. It will come close to the glass and exhibit considerable excitement if hungry, swimming to and fro as you move from side to side in front of it. If there be several in the receptacle, and only one thus behaves, the others soon swim up and join it; in a moment or so you have them all endeavoring to attract your attention to their desires to be fed. Every once in a while one fellow will swim vertically up to the surface of the water, and, sticking his head out, will gulp in a mouthful of air; then, assuming a horizontal poise, slowly sink down again, sometimes to the bottom, or perhaps to rest on some plant growing on it. They are very fond of small bits of angling-worms, and if fed at all times with these, they do not seem to change much in the matter of their coloration; but if the diet be changed to raw meat, it will be noticed that, in a little while, all the colors of the body become of a much

richer and deeper shade. As a rule the back becomes a rich olive brown; the red spots of the sides a deep vermilion; the black spotting more intense, and the pale yellow of all the under-parts a strong orange. When these changes are at their height, the animal is certainly a very beautiful creature.

It need not concern us here about these newts being transformed into the Red Efts or "Mountain Lizards;" for I believe this never happens during the aquarium life of this extraordinary inhabitant of our ponds and sluggish streams.

It is interesting to watch these little fellows at feeding-time. I have often fed them direct from my fingers with bits of raw meat, and if several pieces of this be thrown into the water among them, some curious things happen. Every four or five minutes one of them may give vent to a peculiar kind of short grunt or croak, which may with ease be heard across the room. As the bits of meat fall among them, they all become very much excited, especially if they chance to be pretty hungry. They move about with considerable agility, and snap at everything within reach. As they huddle together, snapping in this manner, they often bite each other, especially the limbs and end of the tail. On one occasion a big female took nearly the entire head of a small male in her mouth, and I was obliged to disengage him from his very uncomfortable predicament. One can easily distinguish the males from the females of this species, as the former have their

hind pair of limbs fully three or four times bigger and thicker than the anterior pair, as will be appreciated by examining the two reproductions of my photographs illustrating the present article. These were taken under water in a small naturalists' aquarium, made especially for the purpose. It is a most useful little affair for that kind of work.

Figure 2 shows a very peculiar habit of this newt which, in so far as I am aware, has not been thus shown before. From time to time, when a male becomes excited from any cause, either from being fed or during the breeding season, he will seize a female around the neck with his hind pair of limbs, almost choking her to death with the vigor of his grasp. With his forelimbs he manages to steady himself in one way or another, and then comes the strangest part of this performance. He curves his tail forwards and vigorously fans the side of the face of the female beneath him, first upon one side and then upon the other. At first she seems to resent this sort of treatment, and makes strong efforts to escape the curious way her admirer adopts to express his appreciation of her attractions; but after a bit she remains quietly on the bottom or rests on some plant growth until he has thoroughly convinced her that she is the most lovable creature known to him, when he relaxes his grasp and reluctantly swims away. I know of no other salamander that practices this rather extraordinary procedure, and it is very well shown here in Figure 2, as I have already stated.

My water newts are kept with several specimens of the red-bellied Newt of Japan, an account of which I gave in *AQUATIC LIFE* for September, 1916 (page 1), where five of the latter species are figured in color.

The New York Show

The annual autumn exhibition of The Aquarium Society, New York City, was held October 12th to 15th, in The American Museum of Natural History. It was a marked success, and an exceptionally fine collection of aquarium fishes was shown.

Mr. A. A. Phillips, Jr., of Brooklyn, entered a splendid lot of goldfish which aroused great admiration, winning two fine silver cups. A cup for goldfish raised during the present year was awarded to Mr. A. Obermiller.

The tropical fishes were well represented by all the favorites, and some very rare species. The silver cup for the best display of adult tropical fishes went to Mr. Isaac Buchanan; that for young tropical fishes, those bred this year, was awarded to Mr. J. Packer.

For the best "balanced aquarium," a silver cup was won by Mr. N. Jasper.

In addition to the many beautiful gold and tropical fishes, many species of aquatic plants, reptiles, lizards, daphne and enchytrae were shown. The display of aquarists' accessories by the Aquarium Stock Company, and the "sanitary aquaria and plant containers" shown by Mr. William S. Smith, were of great interest. Mr. Smith was awarded a special ribbon.

The fishes were judged and the awards made by Mr. William H. Heimbach, Mr. Fred H. Geyer and Dr. E. Bade.—*C. J. Heede.*

Why it pays to advertise in *AQUATIC LIFE*. "It may be of interest to you to know that Mr. Isaac Buchanan, of New York City, who advertised recently in *AQUATIC LIFE*, told me that he was flooded with answers from Maine to California. His fishes were all sold before I reached him."—*Lester E. Wines.*



FUNDULUS GULARIS

WALTER LANNOY BRIND, F. Z. S.

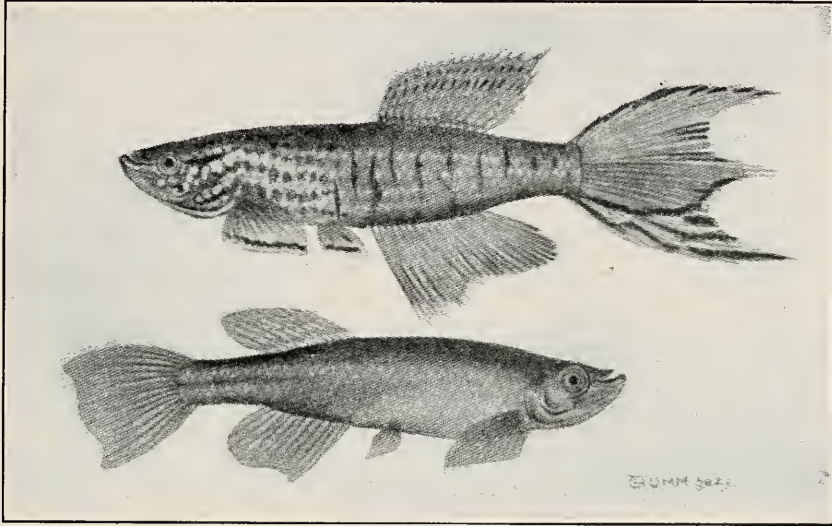

Fundulus gularis (blue variety)

The interesting and peculiar *Fundulus gularis* is a fish little known to most aquarists, and particularly among those of the United States, who have accomplished little in the direct importation of exotic fishes from their native countries. In Germany, however, "der blaue fundulus" is by no means an exceptional denizen of the home aquarium of the advanced aquarist. This *Fundulus* is distinctly a fish that appeals to the expert rather than the beginner. This is doubtless due to the peculiarities of the species, but few aquarists have met with success in its care and propagation. There are two well-pronounced varieties of the species, one blue, the other yellow; the last named the rarest. It is not the purpose of this article to do

more than discuss the blue form, as there is enough to be said about each to warrant separate treatment. The blue *gularis* is a native of West Africa, being found at the mouth of the Niger river. It is quite probable that it has a wider distribution, as it is a very pronounced type, too much so to have become restricted to one small locality.

The facts in regard to its first appearance as an aquarium fish are that in 1905 a sailor, one Groch, brought a single specimen to W. Schrott, a Hamburg fish fancier, by whom it was given to Paul Arnold for identification. Later Carl Siggelkow secured several specimens, and since then almost every shipment from West Africa to Germany has included this fish.

In size *gularis* is a large aquarium fish, males four inches and females three inches in length, being not uncommon among imported specimens. Fish bred in the aquarium will be much smaller than those whose growth was attained under wild and unrestricted surroundings. In coloration the male and female differ. The female is for the most part warm brown, inclining to yellow below, and darker on the back; scales on shoulders more or less spotted with

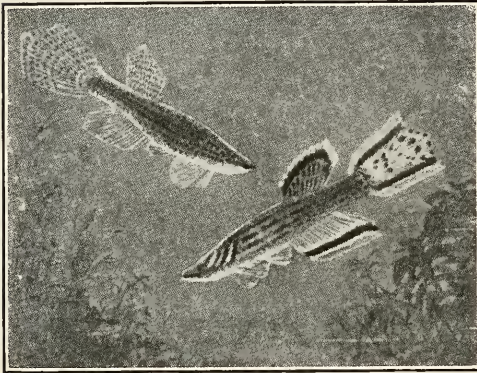

Haplochilus calliurus

dark reddish brown, with spots of same color on the large dorsal fin. The fins in general are bluish gray, those beneath and also the tail inclining to yellow. The anal fin is large and elongated; tail with three lobes instead of two as with most fishes. This last characteristic is most pronounced in the male. The prevalent color of the male is bluish gray; chocolate mottling and marbling over the head and shoulders, developing into narrow, irregular, vertical cross-bars of the same color along the sides. The anal fin is forked and equally divided horizontally by a chocolate line, the upper portion yellowish. Chocolate spots and curved streaks appear on all fins and tail. The middle lobe of the tail is bright yellow—a magnificent contrast to the blue and chocolate of the upper and lower lobes. The

body of both sexes is quite cylindrical in shape, being suggestive of our more familiar friend, *Haplochilus cameronensis*, not only in form, however, but also in marking and coloration, except that blue dominates as the ground color. In habits too *F. gularis* recalls *Haplochilus*, particularly in its tendency to lurk among dense growths of plants.

Propagation is quite difficult in the aquarium as far as raising a large proportion of youngsters to maturity is concerned. The tank must be thickly planted to afford the female shelter from the stormy onslaughts of the male. The larger it is the better the chances of success. Minimum size, 10 gallons; twenty-five gallons if possible. It should be so located that plenty of sunlight will penetrate it, though for but a short time daily. The eggs adhere to threads of algae or lay upon the sandy bottom. Those that float upon the surface of the water invariably become infested with fungus and perish. They hatch in from three to four weeks at a temperature of 75 to 80 degrees, Fahrenheit, and at no time should the parent fish be subjected to a temperature less than 70 degrees. The spawning operation lasts five or six days, after which the parent fish must be removed. Spawning may occur again after an interval of some weeks' inactivity. Some aquarists remove the eggs and float them in saucers on the surface of the water in the aquarium, shielding them from too much direct light.

The care of the young and their feeding is like most other aquarium fishes. They first require infusoria, and as soon as they are able to overcome them, small cyclops and daphne should be given. The addition of sea-water, 1 part to 40 parts fresh water, or table or sea salt in the same proportion is neces-

Concluded on page 54

THE JAPANESE SHUBUNKIN

F. BAMFORD HANNA, B. Sc.

Original Water Color by Frank H. Goodby



Before me as I write is an aquarium, and disporting within its confines of glass are a number of goldfish, a panzerwel or two, and some other fishes. But the ones of which I am most proud are Shubunkins, because, forsooth, I bred them myself. In this, as a mere statement of fact, there is nothing noteworthy. Many other aquarists have bred them, and it is probably the most easily reared of all the fancy breeds of goldfish. What interests me is the varied forms of the youngsters.

The parent fish were long of body, as should be in this breed, and many-colored, being dappled with black and brown on a background of yellow, red, blue and perhaps a little purple. With this fine dress I had high hopes of gorgeous youngsters, hopes, however, that were not entirely realized. The babies,

of which there were several hundred, were as varied a lot of goldfish as I had ever seen. Quite a few were opaque-scaled like the common goldfish, the majority were transparently-scaled, but plain in color, only a few, a very few, approached the colors for which I had hoped. Some of each had double tails, and several with quite deep bodies would pass for fair nymphs. In view of these variations it is remarkable that none had pronounced telescope eyes, though some did have just a tendency in that direction.

The results were really what one should expect from the shubunkin. It is our most recent man-made form of the goldfish, having been originated by a Japanese breeder about fifteen years ago, by crossing the calico telescope with the common goldfish.

Minute Inhabitants of Aquaria

PERRY BRUCE CLARK

San Francisco Aquarium Society

The first step up on the plant side is the group "Algae," the most simple forms of it being single cells. It is this form which is generally found in the aquarium, being seen as a thin green film on the sides (this film is composed of countless numbers of these minute cells). Another sometimes seen is composed of fine, long, green threads. The Algae obtain a part of their nourishment, as do all other green plants, by a

ishment and the Fungi protecting them with their long threads. These plants are called lichens. This is as far as we will go with the plants, returning now to the Bacteria and starting up on the animal side, beginning with the Protozoa or single celled animals.

The first cell which shows the fundamental characteristics of an animal, is the Amoeba or proteus animalcule. This small animal cell is usually found in the slimy coating on submerged leaves and stems in standing water. It is a small speck of clear, colorless, jelly-like substance called protoplasm, with a distinct though delicate outline. This cell contains the nucleus, contractile vacuole and food vacuoles. Amoebae move by throwing out part of the cell into what is called a pseudopod, which may be extended or contracted without changing the place of the amoeba, but if it wishes to move the whole body simply flows into the extended pseudopod, another is extended and the protoplasm flows into the new one, etc. When an amoeba comes in contact with a bit of food material, such as a bacterium or fragment of animal or vegetable cell, it flows around the food, thereby ingesting it. When the bit of food is ingested a small amount of water is also taken in, and this forms what is called a food vacuole. Usually a number of these food vacuoles may be seen in an amoeba in different stages of digestion. If a grain of sand or other indigestible matter is taken in, it is soon passed out of the body, being left behind as the amoeba moves along. There is no mouth, food being taken in

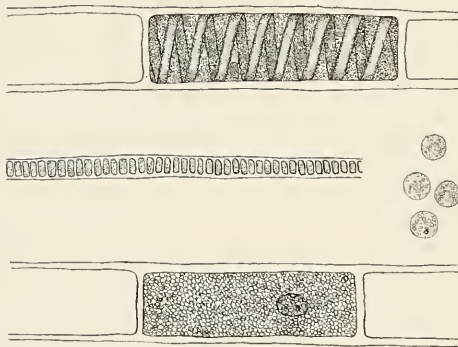

Four Species of Algae

process known as photo-synthesis. Through the action of light and the chlorophyll or green coloring matter they are able to form synthetically starch and cellulose from carbon dioxide and water.

Another group of simple plants is the Fungi. This group contains no chlorophyll, and is almost always parasitic. They either live on another organism or upon some organic matter.

The next group is where the Algae and the Fungi have combined and grow together, being of equal benefit to each other; the Algae furnishing the nour-

at any part of the surface, which is most convenient. There is no stomach; the space occupied by the ingested food serving as an improvised one. There is no anus; the residual matter being passed out at the point most convenient. Oxygen is absorbed by the surface of the body, the contents oxidized, and carbon dioxide given off. This shows respiration in its most simple form. Amoeba multiplies by division, that is,

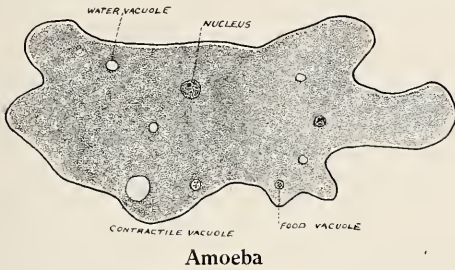

Amoeba

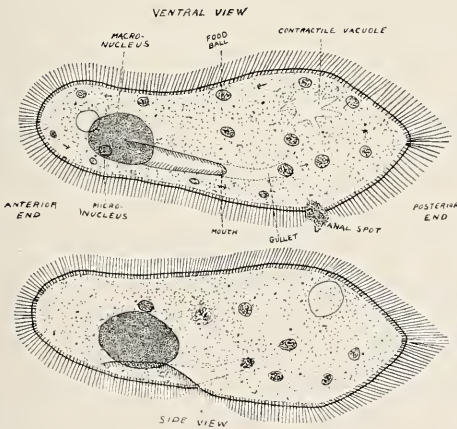

Paramecium

it grows larger, becomes elongated and the nucleus divides in half, a half going to each end of the cell. Finally it becomes constricted in the centre and breaks into two halves, each half becoming a complete new amoeba. This process is not nearly as simple as it seems, for there are numerous minute changes going on among the finer particles of the protoplasm, and in the nucleus.

The next protozoan that we shall discuss belongs to the Infusoria, this is Paramecium, the slipper animalcule, a very good food for fry of egg-laying fishes. Paramecium is slipper-shaped as its name implies, and more pointed at one end than at the other. Its whole surface is covered with cilia or hair-like projections, which wave actively back and forth, and serve the purpose of paddles, by means of which Paramecium swims. At the more pointed end, usually kept in the rear, is a group of longer cilia, which seem to serve the purpose of a rudder. Some times the animal reverses its position and proceeds with the pointed end foremost, but ordinarily for a short time only, generally to back out of a tight place, or when it comes in contact with some obstruction, and desires a new start in another direction. Along the flat surface is a groove which at one end forms a blind passageway, dipping into the body. Both the groove and the tube, which is the gullet, are lined with cilia. By their vibrations these cilia collect small one-celled plants, animals or other particles of organic matter, which accumulate at the inner end of the gullet. From time to time this inner end is cut off by constriction, and the collection of food particles with some water is pushed into the soft protoplasm of the body. It then becomes a food vacuole or improvised stomach. These food vacuoles then slowly rotate around the body, and when they reach a point opposite the gullet, any undigested residue is expelled through a weak place in the wall, there being no permanent anal opening. In the outer portion, which corresponds to the skin of the higher animals, are numerous small sacs, each containing a tiny thread. When the Paramecium is irritated, it discharges these thread or

Aquatic Life

A monthly magazine devoted to the study, care and breeding of native, tropical, gold and fancy fishes, other animals and plants in the household aquarium.

W. A. POYSER Editor
JOSEPH E. BAUSMAN Publisher
542 E. Girard Avenue, Philadelphia

Entered as second-class matter, September 2, 1915, at the Post Office, Philadelphia, Pa., under Act of March 3, 1879.

Yearly Subscription \$1.00
Foreign Subscriptions 1.35
Single Copy 10 cents

Payments may be made by express money order, draft, post office order or registered letter. Foreign remittances should be by international money order.

Advertising rates made known on application.

"Aquatic Life" is the only magazine in America devoted exclusively to aquatic life, and its value as an advertising medium in this field of nature study is unequalled.

Copyright, 1916, by Joseph E. Bausman.

Vol. II December, 1916 No. 4

stinging cells, which appear to produce a stinging or benumbing effect upon small animals. They resemble those found in the Hydra, which is a higher form of animal life. Paramecium multiplies by transverse division, the macro-nucleus and micro-nucleus dividing in half, a part going to each side of the cell, which then becomes constricted in the centre and separates, forming two new individuals.

The Leach

The mention of a leech will recall to most of us the "ole swimmin' hole" of boyhood days. To an aquarist it also means the black, wriggling worm that, with haste and with difficulty, was evicted from the breeding tank. There are quite a number of species of leeches,

ranging in size, when mature, from half an inch to a foot or more in length, the latter the horse-leeches. Some are quite beautifully marked with soft tints of green and yellow. The smaller species and the young of larger forms are quite serious pests as parasites of fishes. The young leeches infect the gills and soft parts of the fishes, gorge themselves with blood, and cause the death of the host. The tiny species are quite hard to combat and sometimes cause epidemics among young goldfish. Little can be done other than to burn the plants and thoroughly disinfect the tank. The trouble is usually caused by eggs introduced with daphne.

Though we may regard them as a whole to be pests, they have, of course,



The Improved Dip Net Made by the
Aquarium Stock Company

a place in nature's processes, and as such are of value. One species, the medicinal leech (*Hirudo medicinalis*), was formerly much used for blood-letting, and still finds a demand far greater than one would imagine. It will surprise most aquarists to learn that the Aquarium Stock Company handles a quarter of a million medicinal leeches annually. Due to the present upheaval in Europe they are rather hard to obtain, and to overcome the difficulty this company has dispatched a man to Europe to collect them.

The mouth of the medicinal leech is peculiarly adapted for blood-letting. The three horny jaws are provided with minute teeth and work backwards and forwards, the mouth being held firmly to the spot by the powerful sucker. The

leech retains its hold until gorged with blood.

The eggs of the leech are placed in cocoons, each containing about twenty surrounded by albumen, and laid in the damp soil above the water-edge. The young, when hatched, float in the albumen and feed upon it for several weeks. They are mature when five years old, but may live to be twenty.

The Aquarium Stock Company must have quite an exciting time handling thousands of these squirming animals. We suspect that for other than financial reasons they would prefer to have AQUATIC LIFE readers told of their many aquarium fishes, and their plants, snails and lizards for aqua-terraria. They take pardonable pride in their fish foods, and particularly in their improved dip net, which with its straight edge is efficient in catching active fishes in the home aquarium.

Philadelphia Goldfish Fanciers

The regular meeting of the Philadelphia Goldfish Fanciers' Society was held in Saul's Hall, 802 Girard avenue, on November 15th.

Scaled and transparently-scaled Broad-tail Jap Goldfish were shown in competition. Messrs. George E. Wilt, George W. Price and Dr. F. C. Leffman, judges, made awards as follows:

Transparently - Scaled Japs.—Silver cup, Joseph E. Bausman; blue ribbon, Joseph E. Bausman; red ribbon, John Whitaker; yellow ribbon, Howard E. Demuth.

Scaled Japs.—Silver cup, William J. Christy; blue ribbon, George B. Smith; red ribbon, Joseph E. Tyler; yellow ribbon, George B. Smith.

Mr. C. G. B. Schenk, honorary president of the Milwaukee Aquarium Society, was present and gave an interest-

ing talk on the present trend of the goldfish fancy.

Interest in the competition for the diamond scarf pin, to be presented by Mr. George W. Price to the member securing the greatest number of new members before the next banquet, continues without abatement. At this meeting, Messrs. Andrew J. Haag, Jr., James A. McDevitt, Nils Nilsson, Albert P. Miller, John Langan and John F. Ahlers became members.

At the next meeting, December 20th, the competition will be for Lionheads, Orandas and Celestial Telescopes. Prizes: Lionheads, silver cup and three ribbons; Orandas, silver cup and three ribbons; Celestial Telescopes, three ribbons.—*Fred Richardson, secretary.*

The Boston Society

Following a preliminary gathering in October, the Boston Aquarium Society held its first regular meeting at Holden's bird store, Friday evening, November 17th. Officers were elected as follows: President, Walter M. Copeland; vice-president, Franklin A. Packard; secretary, Walter H. Chute; treasurer, Charles W. Alden.

The society starts with a membership of nineteen, and at least ten aquarists have signified their intention of becoming members at the next meeting. We hope to co-operate with the other societies throughout the country to encourage the development and study of aquaria and terraria and their inhabitants by means of informal meetings, exhibitions and the distribution of literature.

The society is fortunate in having the indorsement of the Massachusetts Fish and Game Commission, and sends to its brother societies the following from a message from Hon. William C.

Adams, chairman of the Commission: "We cannot see how anything but good can result from the activities of your society, and we hope it will have a long life and a large membership. There should be no effort to narrow the field of study and investigation, as it relates to our wild life. The farther we can reach out the more we are bound to learn, and to appreciate how completely one form of life is linked with other forms. The objects of your society should not only promote a great deal of pleasant recreation for the young and old of the country, but very easily can be made the foundation for much intelligent research and study."

Until further notice the regular meetings of the society will be held on the second Friday of the month at 15 Broomfield street. Aquarists of other cities who may be in Boston at any time, are cordially invited to attend the meetings. The secretary will be pleased to correspond with the officers of the other societies relative to the work.—*Walter H. Chute, secretary.*

Propagating Daphnia

Mr. Bennington, in his article on the propagation of daphne which appeared in the October number, rather discouraged thoughts of the possibility of this being done on a scale sufficient for goldfish breeding. He made it plain, however, that the proposition was dependent upon large pond area, and that it could be done if such was available. It is a pleasure to announce that the desired end has been accomplished by a goldfish fancier, Mr. Otto Gneiding, who, in an early issue, will describe the method he has followed to propagate sufficient for thousands of goldfish, and to supply the needs of some friends and customers.

Regenia Salts is the name of a compound that is offered to aquarists by the manufacturers of the well-known *Violet Ray* remedy. Added to the water of the aquarium at intervals, it is intended to replace the solids absorbed by the fishes and snails. While new it is becoming quite popular and enjoying a great demand.

In the list of awards and classification of entries in the annual exhibition of the St. Louis Aquarium Society, held November 20th to 25th, we note classes for "Philadelphia style" scaled and scaleless veiltail goldfish. This recognition should be flattering to Philadelphia goldfish fanciers.

The collie is a beautiful dog, a docile pet, and a mighty useful means of keeping the cats away from your goldfish tank while you have them outside. Why not give yourself a Christmas present? Tappan has a fine lot of puppies that he wishes to sell.

Brind advertises "Cut-price fishes." Ever see an advertisement that offered fishes cut in half? We have!

Who is wise? He that learns from everyone!

Concluded from Page 48

sary to obtain best results. Taking everything into consideration, *Fundulus gularis*, both varieties, is a fish for expert equarists.

The name *Fundulus* is derived from *fundus*, meaning bottom; *gularis* refers to the relatively large head and throat, a characteristic particularly noticeable in poor emaciated specimens which are more often seen than healthy well-fed ones.

Aquarium Societies

Brooklyn Society Incorporated	<i>President</i> —JOSEPH FROEHLICH11 St. Francis Place <i>Corresponding Secretary</i> —CARLTON H. CHAPIN39 Kenilworth Place <i>Recording Secretary</i> —WILLIAM D. SARGENT129 Columbia Heights <i>Treasurer</i> —GEORGE W. POST52 Herkimer Street
American Federation of Goldfish Fanciers Brooklyn	<i>President</i> —MATTHEW BOWMAN427 Forty-fourth Street <i>Vice-President</i> —JAMES J. HOARE752 Monroe Street <i>Treasurer</i> —JOHN DEBUS313 South Fourth Street <i>Secretary</i> —MRS. M. BOMAN427 Forty-fourth Street
Aquarium Society of Philadelphia	<i>President</i> —H. R. LIPPINCOTTCollingswood, N. J. <i>Vice-President</i> —H. S. FULLETON135 West Wyoming Avenue <i>Secretary</i> —WALTER LEE ROSENBERGERP. O. Box 66, Philadelphia <i>Treasurer</i> —R. L. HARDING6008 Master Street
Philadelphia Goldfish Fanciers	<i>President</i> —GEORGE B. SMITH2013 East Cumberland Street <i>Vice-President</i> —HARRY P. PETERS1210 N. Warnock Street <i>Secretary</i> —FRED. RICHARDSON3841 N. Marshall Blvd. <i>Treasurer</i> —GEORGE W. PRICE2145 South Lee Street
The Aquarium Society New York	<i>President</i> —RICHARD DORNUpper Montclair, N. J. <i>Vice-President</i> —DR. E. BADEGlenhead, L. I., N. Y. <i>Secretary</i> —HOWLAND WOOD156th Street and Broadway <i>Assistant Secretary</i> —CLARENCE B. RUCH615 West 155th Street <i>Treasurer</i> —J. P. LOWELL146 Grace Street, Jersey City, N. J.
Chicago Aquarium Society Incorporated	<i>President</i> —S. H. LINDAHL6733 Ridgland Avenue <i>Vice-President</i> —H. W. KEEDY19 East Cedar Street <i>Secretary</i> —FRED. G. ORSINGER123 South Oakley Blvd. <i>Treasurer</i> —G. J. BORGSTROM, JR.1408 North Kedzie Avenue
Milwaukee Society	<i>President</i> —LIBORIUS SEMMANN752½ Thirty-eighth Street <i>Vice-President</i> —E. P. KUECKHEFER99 Seventeenth Street <i>Corresponding Secretary</i> —REV. G. KELLER RUBRECHT999 Island Avenue <i>Recording Secretary</i> —REV. PAUL ROTH2602 Prairie Street <i>Treasurer</i> —GEORGE J. C. STEFFENS950 First Street
Reading Society	<i>President</i> —JOHN KERSHNER223 South Third Street <i>Vice-President</i> —W. H. HIMMERSHITZ220 Pier Street <i>Secretary and Treasurer</i> —S. O. MELLERT120 West Windsor Street
Lancaster Society	<i>President</i> —HIRAM PEOPLESNew Providence, Pa. <i>Vice-President</i> —H. H. MYERS431 West Orange Street <i>Secretary and Treasurer</i> —W. M. HAWMAN250 East Ross Street
Minneapolis Society	<i>President</i> —F. L. TAPPAN92 South Seventh Street <i>Treasurer</i> —J. W. FRANZENMuseum, Public Library <i>Secretary</i> —MRS. ANNA ESSENE3421 South Longfellow Avenue
Pittsburgh Society	<i>President</i> —DR. O. T. CRUCKSHANK5148 Jenkins' Arcade <i>Vice-President</i> —A. A. ALLEN221 Belthoover Avenue <i>Treasurer</i> —C. J. MERTEN24 Chalfont Street <i>Secretary</i> —E. W. HARPER424 Jaconda Street
National Society St. Louis	<i>President</i> —S. CHICHESTER LLOYD4442 Morganford Road <i>Vice-President</i> —A. H. THURSBY3005 Osage Street <i>Treasurer</i> —G. H. FOX5041-A Alabama Avenue <i>Secretary</i> —CHARLES A. KLOEPPER4412 Natural Bridge Road
Washington Society	<i>Honorary President</i> —DR. HUGH M. SMITHU. S. Fisheries Bureau <i>Active President</i> —DR. R. W. SHUFELDT3356 Eighteenth Street, N. W. <i>Vice-President</i> —LOUIS W. BAUER722 K Street, N. E. <i>Vice-President</i> —MRS. L. HELEN FOWLERKenilworth, D. C. <i>Secretary</i> —JAMES E. BENEDICT945 Pennsylvania Avenue <i>Treasurer</i> —EDWARD S. SCHMID712 Twelfth Street, N. W.
San Francisco Society	<i>President</i> —F. S. CURTIS760 Church Street <i>Vice-President</i> —W. J. RICHARDS449 O'Farrell Street <i>Secretary and Treasurer</i> —HARRY A. KNIGHT60 California Street
Casler County Society	<i>President</i> —LOTHAIR SMITHEast Orange, N. J. <i>Vice-President</i> —DR. WILLIAM BACHMANN247 Littleton Avenue <i>Secretary</i> —GEORGE HOERNIG465 Clinton Avenue <i>Treasurer</i> —MAX G. HAMMERSCHLAG35 Nelson Place

EXTRAORDINARY LIMITED OFFER TO AQUATIC LIFE READERS

By special agreement, we have arranged a remarkable money-saving introductory campaign through which our readers may

obtain Aquatic Life in club with splendid periodicals for the home, for only a fraction of their real value.

The Publishers Will Mail the Magazine Direct From Their Own Office to You

To take advantage of this remarkable opportunity you should act at once, as the offers are good for a limited time only. Present subscribers to any of these magazines may have their subscriptions extended.

The magazines may be sent to one address or each to a different address. This gives you an opportunity to have your

friends subscribe with you or to use the magazine subscriptions as gifts to your friends or relatives. Each subscription is for one year. Extra postage is necessary on Canadian and foreign subscriptions.

Remit by money order, check, United States stamps or currency, as most convenient. Please use the coupon below.

<table style="width: 100%; border-collapse: collapse;"> <tr> <td style="width: 60%;">Aquatic Life\$1.00</td> <td rowspan="3" style="font-size: 3em; vertical-align: middle;">}</td> <td style="width: 40%;">OUR PRICE</td> </tr> <tr> <td>American or Every- body's 1.50</td> <td rowspan="2" style="font-size: 3em; vertical-align: middle;">\$2.00</td> </tr> <tr> <td>Regular Price ... \$2.50</td> </tr> <tr> <td>Aquatic Life\$1.00</td> <td rowspan="2" style="font-size: 3em; vertical-align: middle;">}</td> <td>OUR PRICE</td> </tr> <tr> <td>Everyland or Boys' Magazine 1.00</td> <td rowspan="2" style="font-size: 3em; vertical-align: middle;">1.50</td> </tr> <tr> <td>Regular Price .. \$2.00</td> </tr> <tr> <td>Aquatic Life\$1.00</td> <td rowspan="2" style="font-size: 3em; vertical-align: middle;">}</td> <td>OUR PRICE</td> </tr> <tr> <td>Gardening or Chris- tian Herald 2.00</td> <td rowspan="2" style="font-size: 3em; vertical-align: middle;">2.00</td> </tr> <tr> <td>Regular Price ... \$3.00</td> </tr> <tr> <td>Aquatic Life\$1.00</td> <td rowspan="2" style="font-size: 3em; vertical-align: middle;">}</td> <td>OUR PRICE</td> </tr> <tr> <td>Housewife and To- days 1.00</td> <td rowspan="2" style="font-size: 3em; vertical-align: middle;">1.50</td> </tr> <tr> <td>Regular Price ... \$2.00</td> </tr> <tr> <td>Aquatic Life\$1.00</td> <td rowspan="2" style="font-size: 3em; vertical-align: middle;">}</td> <td>OUR PRICE</td> </tr> <tr> <td>McCall's and De- signer 1.50</td> <td rowspan="2" style="font-size: 3em; vertical-align: middle;">2.00</td> </tr> <tr> <td>Regular Price ... \$2.50</td> </tr> <tr> <td>Aquatic Life\$1.00</td> <td rowspan="2" style="font-size: 3em; vertical-align: middle;">}</td> <td>OUR PRICE</td> </tr> <tr> <td>Ladies' World and Every Week 2.00</td> <td rowspan="2" style="font-size: 3em; vertical-align: middle;">2.50</td> </tr> <tr> <td>Regular Price ... \$3.00</td> </tr> <tr> <td>Aquatic Life\$1.00</td> <td rowspan="2" style="font-size: 3em; vertical-align: middle;">}</td> <td>OUR PRICE</td> </tr> <tr> <td>Table Talk, The Na- tional Food Maga- zine 1.00</td> <td rowspan="2" style="font-size: 3em; vertical-align: middle;">1.50</td> </tr> <tr> <td>Regular Price ... \$2.00</td> </tr> </table>	Aquatic Life\$1.00	}	OUR PRICE	American or Every- body's 1.50	\$2.00	Regular Price ... \$2.50	Aquatic Life\$1.00	}	OUR PRICE	Everyland or Boys' Magazine 1.00	1.50	Regular Price .. \$2.00	Aquatic Life\$1.00	}	OUR PRICE	Gardening or Chris- tian Herald 2.00	2.00	Regular Price ... \$3.00	Aquatic Life\$1.00	}	OUR PRICE	Housewife and To- days 1.00	1.50	Regular Price ... \$2.00	Aquatic Life\$1.00	}	OUR PRICE	McCall's and De- signer 1.50	2.00	Regular Price ... \$2.50	Aquatic Life\$1.00	}	OUR PRICE	Ladies' World and Every Week 2.00	2.50	Regular Price ... \$3.00	Aquatic Life\$1.00	}	OUR PRICE	Table Talk, The Na- tional Food Maga- zine 1.00	1.50	Regular Price ... \$2.00	<table style="width: 100%; border-collapse: collapse;"> <tr> <td style="width: 60%;">Aquatic Life\$1.00</td> <td rowspan="3" style="font-size: 3em; vertical-align: middle;">}</td> <td style="width: 40%;">OUR PRICE</td> </tr> <tr> <td>Something to Do (for Children) 1.00</td> <td rowspan="2" style="font-size: 3em; vertical-align: middle;">\$1.50</td> </tr> <tr> <td>Regular Price ... \$2.00</td> </tr> <tr> <td>Aquatic Life\$1.00</td> <td rowspan="2" style="font-size: 3em; vertical-align: middle;">}</td> <td>OUR PRICE</td> </tr> <tr> <td>Musician or Parisi- enne 1.50</td> <td rowspan="2" style="font-size: 3em; vertical-align: middle;">2.00</td> </tr> <tr> <td>Regular Price ... \$2.50</td> </tr> <tr> <td>Aquatic Life\$1.00</td> <td rowspan="2" style="font-size: 3em; vertical-align: middle;">}</td> <td>OUR PRICE</td> </tr> <tr> <td>Short Stories or Young's 1.50</td> <td rowspan="2" style="font-size: 3em; vertical-align: middle;">2.00</td> </tr> <tr> <td>Regular Price ... \$2.50</td> </tr> <tr> <td>Aquatic Life\$1.00</td> <td rowspan="2" style="font-size: 3em; vertical-align: middle;">}</td> <td>OUR PRICE</td> </tr> <tr> <td>Everybody's 1.50</td> <td rowspan="2" style="font-size: 3em; vertical-align: middle;">3.00</td> </tr> <tr> <td>Deflector 1.50</td> </tr> <tr> <td>Regular Price ... \$3.00</td> </tr> <tr> <td>Aquatic Life\$1.00</td> <td rowspan="2" style="font-size: 3em; vertical-align: middle;">}</td> <td>OUR PRICE</td> </tr> <tr> <td>Ladies' World 1.00</td> <td rowspan="2" style="font-size: 3em; vertical-align: middle;">2.50</td> </tr> <tr> <td>Mother's Magazine... 1.50</td> </tr> <tr> <td>Regular Price ... \$3.50</td> </tr> <tr> <td>Aquatic Life\$1.00</td> <td rowspan="2" style="font-size: 3em; vertical-align: middle;">}</td> <td>OUR PRICE</td> </tr> <tr> <td>Field and Stream ... 1.50</td> <td rowspan="2" style="font-size: 3em; vertical-align: middle;">2.00</td> </tr> <tr> <td>Regular Price ... \$2.50</td> </tr> <tr> <td>Aquatic Life\$1.00</td> <td rowspan="2" style="font-size: 3em; vertical-align: middle;">}</td> <td>OUR PRICE</td> </tr> <tr> <td>Pictorial Review ... 1.50</td> <td rowspan="2" style="font-size: 3em; vertical-align: middle;">3.00</td> </tr> <tr> <td>Popular Science Monthly 1.50</td> </tr> <tr> <td>Regular Price ... \$4.00</td> </tr> </table>	Aquatic Life\$1.00	}	OUR PRICE	Something to Do (for Children) 1.00	\$1.50	Regular Price ... \$2.00	Aquatic Life\$1.00	}	OUR PRICE	Musician or Parisi- enne 1.50	2.00	Regular Price ... \$2.50	Aquatic Life\$1.00	}	OUR PRICE	Short Stories or Young's 1.50	2.00	Regular Price ... \$2.50	Aquatic Life\$1.00	}	OUR PRICE	Everybody's 1.50	3.00	Deflector 1.50	Regular Price ... \$3.00	Aquatic Life\$1.00	}	OUR PRICE	Ladies' World 1.00	2.50	Mother's Magazine... 1.50	Regular Price ... \$3.50	Aquatic Life\$1.00	}	OUR PRICE	Field and Stream ... 1.50	2.00	Regular Price ... \$2.50	Aquatic Life\$1.00	}	OUR PRICE	Pictorial Review ... 1.50	3.00	Popular Science Monthly 1.50	Regular Price ... \$4.00
Aquatic Life\$1.00	}		OUR PRICE																																																																																					
American or Every- body's 1.50			\$2.00																																																																																					
Regular Price ... \$2.50																																																																																								
Aquatic Life\$1.00	}	OUR PRICE																																																																																						
Everyland or Boys' Magazine 1.00		1.50																																																																																						
Regular Price .. \$2.00																																																																																								
Aquatic Life\$1.00	}	OUR PRICE																																																																																						
Gardening or Chris- tian Herald 2.00		2.00																																																																																						
Regular Price ... \$3.00																																																																																								
Aquatic Life\$1.00	}	OUR PRICE																																																																																						
Housewife and To- days 1.00		1.50																																																																																						
Regular Price ... \$2.00																																																																																								
Aquatic Life\$1.00	}	OUR PRICE																																																																																						
McCall's and De- signer 1.50		2.00																																																																																						
Regular Price ... \$2.50																																																																																								
Aquatic Life\$1.00	}	OUR PRICE																																																																																						
Ladies' World and Every Week 2.00		2.50																																																																																						
Regular Price ... \$3.00																																																																																								
Aquatic Life\$1.00	}	OUR PRICE																																																																																						
Table Talk, The Na- tional Food Maga- zine 1.00		1.50																																																																																						
Regular Price ... \$2.00																																																																																								
Aquatic Life\$1.00	}	OUR PRICE																																																																																						
Something to Do (for Children) 1.00		\$1.50																																																																																						
Regular Price ... \$2.00																																																																																								
Aquatic Life\$1.00	}	OUR PRICE																																																																																						
Musician or Parisi- enne 1.50		2.00																																																																																						
Regular Price ... \$2.50																																																																																								
Aquatic Life\$1.00	}	OUR PRICE																																																																																						
Short Stories or Young's 1.50		2.00																																																																																						
Regular Price ... \$2.50																																																																																								
Aquatic Life\$1.00	}	OUR PRICE																																																																																						
Everybody's 1.50		3.00																																																																																						
Deflector 1.50																																																																																								
Regular Price ... \$3.00																																																																																								
Aquatic Life\$1.00	}	OUR PRICE																																																																																						
Ladies' World 1.00		2.50																																																																																						
Mother's Magazine... 1.50																																																																																								
Regular Price ... \$3.50																																																																																								
Aquatic Life\$1.00	}	OUR PRICE																																																																																						
Field and Stream ... 1.50		2.00																																																																																						
Regular Price ... \$2.50																																																																																								
Aquatic Life\$1.00	}	OUR PRICE																																																																																						
Pictorial Review ... 1.50		3.00																																																																																						
Popular Science Monthly 1.50																																																																																								
Regular Price ... \$4.00																																																																																								

AQUATIC LIFE

542 E. Girard Avenue, Philadelphia

Enclosed find \$_____ for which please send the magazines mentioned opposite, to the addresses indicated, each for a full year.

Name of sender

Street address

Town

Date..... State.....

SendMagazine to

Name

Address

SendMagazine to

Name

Address

Magazines Make Excellent Christmas Gifts

Books for Aquarists



The Home Aquarium and How to Care for It. A guide to its fishes, other animals and plants. By Eugene Smith. 213 pages, 137 illustrations, cloth binding, \$1.20. Add parcel postage on two pounds.



Goldfish and Its Culture. Practical instructions for pond breeding, shipping, care of the aquarium, and the general subject. By Hugo Mullertt. 155 pages, 15 illustrations, cloth binding. \$2.00. Add parcel postage on two pounds.



Fish Culture in Ponds and Inland Waters. The most recent book, covering the propagation of goldfish, food and game fishes, and aquarium management. By William E. Meehan, Director of the Fairmount Park Public Aquarium, Philadelphia, and former Pennsylvania State Fish Commissioner. 287 pages, 22 illustrations, cloth binding. \$1.00. Add parcel postage on one pound.



Japanese Goldfish. A guide to the Japanese methods of culture. By Dr. Hugh M. Smith, U. S. Commissioner of Fisheries. 10 full-page colored plates, numerous text cuts, 112 pages, cloth binding. \$2.00. Add parcel postage on two pounds.



Life of Inland Waters. Needham and Lloyd. A big book containing 438 pages and 244 splendid illustrations. It presents a survey of the whole realm of freshwater aquatic life. The only American publication on the subject, and one that will materially assist the aquarist in solving the many problems encountered. \$3.00. Add parcel postage on three pounds.



The Freshwater Aquarium and Its Inhabitants. A practical work for the aquarist. By Egging and Ehrenberg. Freely illustrated, 352 pages, art cloth binding. \$2.00. Add parcel postage on two pounds.



Address **AQUATIC LIFE**

Book Department

542 East Girard Avenue, Philadelphia

The Nature Study Review

OFFICIAL JOURNAL
AMERICAN NATURE-STUDY
SOCIETY

The numbers for the coming school year will be filled with special articles from practical teachers dealing with actual works, methods and suggestions for school gardening, elementary agriculture and nature-study.

DO NOT MISS ANY OF THEM

\$1.00 per year.

15c per copy.

SUBSCRIBE NOW

Add for Canadian Postage, 10c. Foreign Postage, 20c. With Aquatic Life One Year, \$1.50.

Address All Orders to

The Nature Study Review

ITHACA, N. Y.

CARL LAZER

Dealer and Breeder of Tropical Fishes

AQUARIUM PLANTS RED SNAILS

ALL KINDS OF AQUARIA & SUPPLIES

Open Evenings Only, or by Appointment

228 East 18th Street, New York City, N. Y.

CASH FOR MANUSCRIPTS

Of Interest To Aquarists

Write Me Fully in First Letter

ADDRESS, ALBERT G. GEIGER

142 N. Collington Ave., Baltimore, Md.

AQUARIUM STOCK CO.

150 Chambers Street, New York City

Aquarium Specialists

GOLDFISH, FOODS, PLANTS, SNAILS, ETC.

Combination Natural Fish Food - - Sample Can 10c

Imported Shrimp Fish Food - - - Sample Can 15c

Imported Wafer Fish Food - Large Sample Box 10c

Special Prices on Quantity Lots

Cash With Order

Catalogue Sent Upon Request

ORDERS AMOUNTING \$2 DELIVERED POSTPAID

Mail Orders Promptly Attended To

Aquatic Life

Aquatic Life. Volume One. America's aquarian naturalists have collaborated to make "Aquatic Life" a practical cyclopaedia for the aquarist. The first volume, 166 pages, is complete. Every essential phase of this fascinating branch of nature-study is treated; special articles, splendidly illustrated, cover goldfish breeding, native and exotic species; the care of the aquarium, and the general subject. The illustrations, more than one hundred, some in color, include the finest that have ever been published of the various goldfish breeds. "Aquatic Life" is conceded the best illustrated aquarists' magazine in the world. The volume costs two dollars, postage prepaid.

Address **Aquatic Life**

(Book Department)

542 East Girard Avenue, Philadelphia

EDWARD S. SCHMID

Emporium of Pets

ALL KINDS OF GOLDFISHES AND AQUATIC PLANTS AND WATER LILIES

712 Twelfth Street, N. W., Washington, D. C.

Taxidermy

Send for Catalog

DRIED SHRIMP - (Ground 75c per Pound)

Postpaid

Special Price on Quantity Lots

My Natural Fish Food Sample can 15c Per Pound \$1.00

CANADIAN BIRD STORE

2139 W. Van Buren Street

Chicago, Ill.

ONCE YOU TRY, YOU ALWAYS BUY Gnadt's Perfect Fish Food, 10c a Box

Pulverized or Whole Shrimp, 75c lb.

BREEDER OF FANCY GOLD AND TROPICAL FISHES

Manufacturer of all kinds of aquariums

Fish nets made of finest netting, 15c.

Great reduction by dozen or gross.

BROADWAY BIRD STORE

P. F. GNADT, Prop.

1632 Broadway Greenhouse 1630 Broadway
BROOKLYN, N. Y.

HALLER'S

Harz Mountain Bird Store

Wholesale and Retail Importer and Dealer in

Genuine Harz Mountain & St. Andreasburg

CANARIES

Gold Fish, Globes, Pigeons, Pet Dogs, Dog
Medicine, Poultry Supplies

Full Line of Best Imported German Bird Seeds Always on Hand

1108 VINE STREET

CINCINNATI, OHIO

R. PEGLOW

Dealer and Breeder of **Fancy Goldfish**

Broad-tail Telescopes My Specialty

All Kinds of Aquaria and Supplies

557 WOODWARD, AVE., BROOKLYN, N. Y.

USE REGENIA AQUARIUM SALTS

To replace natural salts in waters
as absorbed by fish and snails
6 POWDERS IN BOX, 25 CENTS

Regenia Chemical Co., Sta. K, Philadelphia

ENCHYTRAE

The Secret of Successful Breeding of Tropical
Fishes and the Ideal Live Fish Food.

Portion, 50c (cash or money order) with Instructions how to breed them

CHARLES E. JENNE

109 22nd Street

West New York, N. J.



You could not live on bread alone. Have you ever thought of what a miserable existence you would have to live on bread alone. You must have a variety of food to enjoy life and keep in good health. Remember your fishes require the same. Yogi ingredients are changed continuously and your fish get a variety of nourishing food.

Robert J. Schaeffer

1818 Frankford Ave., Phila. Sample 12c

"AQUARIA FISH"

A practical work on care and breeding of fish in the Aquarium, Greenhouse and outdoor Ponds. Finely illustrated. Every one interested in keeping fish should send for a copy of this book. Price, \$1.

Four-Horned Snails (*Ampullaria Gigas*) deposit a mass of large coral red eggs out of the water, the little snails drop into the water as they hatch. These snails are invaluable for destroying Hydra in the aquarium.

Thoroughbred Collie Pups, beautifully marked.

F. L. TAPPAN

92 S. 7th Street, Minneapolis, Minn.

WALTER BELL

Breeder of **Broad-tail Telescopes**

BLUES BLACKS CALICOS

4324 WYALUSING AVENUE, PHILADELPHIA

Prices Reasonable

THE TERMINAL PET SHOP

PETS OF EVERY DESCRIPTION AND KIND

Manufacturing and Maintenance of Aquariums a Specialty

All Kinds of Cat and Dog Foods and Medicines

HUDSON TERMINAL BUILDING

Concourse, New York

TEN VARIETIES OF BEAUTIFUL AQUARIUM PLANTS

for \$1.00 Postage Postpaid

J. HENRI WAGNER, 1909 North Capitol
Washington, D. C.

VIOLET RAY FISH REMEDY

Relieves Constipation, Fungus, Tail Rot,
Congestion. Safe and effective. **Box of six
powders 25c.** For sale at Pet Stock Stores,
or address

REGENIA CHEMICAL CO., Sta. K, Philadelphia

“Everything is Fish that comes to the Net of a Naturalist”

Don't paddle in the water with one
hand and be blind with both eyes.

In other words, “keep your eyes open”
for all nature.

OUR MAGAZINE

The Guide to Nature

WILL HELP YOU

It is edited by **Edward F. Bigelow**,
who fishes in the heavens and earth, as
well as the waters under the earth.

Single copy, 10c.

Four months' trial, 25c.

One year, \$1.00.

THE AGASSIZ ASSOCIATION

ArcAdia

Sound Beach

Connecticut

Cut Price Fishes!

Danio Albolineatus\$1.00 pair

Danio Rerio 75c pair

Barbus Semifasciolatus 75c pair

Lebistes Reticulatus 50c pair

(While they last!)

Send empty can prepaid or add 15c. My
reason for above prices is to make room for
big importation of new species and because
I need the money, having just come out of
the hospital!

SPECIAL! 1 Pr. Danio Rerio Free! To
all new subscribers ordering my book,
“Domesticated Fish”—price \$2.60 postpaid
—before January 1, 1917. Mention this ad.
or no fish sent!

IMPORTANT! If you can use 10 Prs. of
Import. Holbrooki, Notropis Metallicus
Mollienia Velifera or **Southern Sunfish**,
let me hear from you. Can save you big
money! Here's your chance to make big
money!

W. L. BRIND, IMPORTING AQUARIST,

449 West 206th St., New York City.

'Phone, St. Nicholas 8418, If Calling.

Broad-tail Telescopes

Correspondence Solicited

GEORGE WILT, 1519 N. 62d Street

PHILADELPHIA

THE BRUCE FISHERIES

Breeder, Importer, Wholesale & Retail Dealer in

All Kinds of Goldfish

Comets a Specialty

ELGIN K. BRUCE, THORNBURG, IA.

CALICO TELESCOPE YOUNG

\$5.00 per Dozen

TRY I. X. L. BABY FISH FOOD

WILLIAM E. WALP

1309 North 55th Street, Philadelphia

FRANKLIN BARRETT

EVERYTHING COMPLETE FOR THE
AQUARIUM, POND AND LAKE

Wyoming Avenue, & C Street, Phila., Pa.

SEND FOR PRICE LISTS

Aquariums of Artistic Designs

Strongly Built, Suitable for the Home, Conservatory, College or Store

Also all aquarium supplies. We make any size aquarium to order, slate or iron-bottom. Write your wants. Dealers with card write for lowest wholesale prices on globes, food and plants.

WE HAVE FOR SALE

Used Little Wonder pump, 25-gallon tank, gauge and regulation valve. Price \$15.00.

Address **PIONEER AQUARIUM CO.**
Racine, Wisconsin.

HERMAN RABENAU, Aquarist

PERMANENT DISPLAY OF

Aquatic Life and Terraria

must be seen to be appreciated

Visitors Welcome

Plants and Tropical Fish a Specialty

Importations of New Varieties received regularly

1163 Myrtle Avenue, Brooklyn, N. Y.
Near Broadway.

Nippon Goldfish Co.

1749 Buchanan Street, San Francisco, Cal.

Importers : and : Dealers

JAPANESE GOLDFISH

DIRECT FROM BREEDERS IN JAPAN

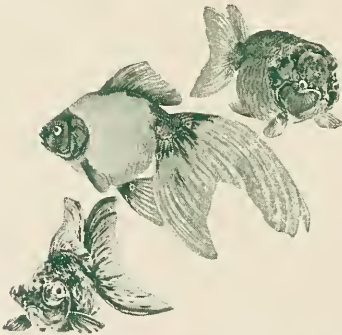

AWARDED GOLD & SILVER MEDALS
Panama-Pacific International Exposition
San Francisco, 1915

ALL KINDS OF AQUARIA AND SUPPLIES
Price Lists Furnished to the Trade Only

HARRY P. PETERS

1210 N. Warnock Street, Philadelphia, Pa

BREEDER AND IMPORTER

Rare and Fancy Fish

Plants of every variety, Snails and Aquarium Supplies of all kinds at all times.

MANUFACTURER OF

Green River Fish Food

10c a Box

Green River Baby Fish Food

15c a Box

A GOOD FISH FOOD is one of the most essential things necessary to keep fish in good health. After the test of years Green River stands out as the best food on the market. It keeps the fish in good color by promoting a healthy, robust growth. It will not sour or cloud the water. Ask your dealer or send for it today.

Otto Walter

86 Suydam Street :: Brooklyn, N. Y.

Near Evergreen Avenue L Station

Breeder and Importer of

TROPICAL AND GOLDFISHES

Telescopes Calicos Japs Fan-tails

Dealer in All Varieties of Aquatic Plants

All Kinds of Fish Foods

Fresh and Dried Daphnia

AQUARIA, UTENSILS AND SUPPLIES

GENUINE IMPORTED

Japanese Fantail Goldfish - 50 or 75c Each

Black Telescopes - - - \$1.50 Each

Pails Extra. Aquatic Plants 25c Postpaid

Above Fish Are Genuine Imported Stock With Short Egg-shaped Bodies and Brilliant Colors

MAX GEISLER BIRD CO.

OMAHA, NEBR.

BIRDS AND PET ANIMALS

28 Years in Business

50,938

January, 1917

10 CENTS

Aquatic Life



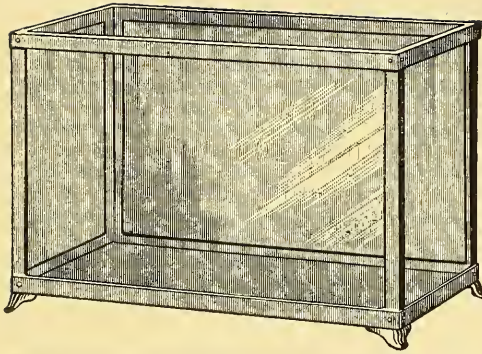

Jacob C. Cassel
915 Arch Street, Philadelphia, Pa

Manufacturer of

AQUARIUMS

Aquarium Ornaments

Floral Terra Cotta, Etc.

Goldfish Fish Globes Fish Food
and all aquarium requisites.
Send for Catalog.

**Aquarium Specialty Co. 1873 WASHINGTON AVENUE
NEW YORK CITY**

**MANUFACTURERS OF AQUARIA, FOUNTAINS, TERRARIA, VIVARIA
BREEDERS OF DOMESTICATED FISHES
IMPORTERS OF FOREIGN FISHES
AQUATIC PLANTS, SNAILS AND SUPPLIES**

STOCK AQUARIA

**Galvanized Metal Frame, Enameled
and Gold-Striped, Bottom Slate or
Ribbed Glass.** Plain. On legs

No. 1.	11"x7"x7"	\$1.25	\$1.50
" 2.	14"x9"x9"	1.50	2.00
" 3.	17"x11"x11"	...	2.25	2.75
" 4.	20"x13"x13"	...	3.00	3.75
" 5.	24"x12"x14"	...	4.75	5.50

20% additional for oxidizing.

**Solid Brass Frame, on Projecting
Slate Bottom or on Legs.**

No. 1.	12"x 6"x 8" high,	2½ gal.	\$2.50
" 2.	14"x 8"x10"	" 5 "	3.25
" 3.	16"x10"x12"	" 9 "	4.75
" 4.	18"x12"x14"	" 14 "	5.75

20% additional for nickel-plating or oxidizing.

**Steel Angle Frame, Heavy Plate
Glass, Slate Bottom, Flush or Pro-
jecting.**

No. 3½.	24"x14"x14",	22 gal.	\$8 00
" 4½.	30"x16"x16",	36 "	12 50
" 5½.	36"x18"x18",	54 "	20 00
" 6½.	42"x20"x20",	80 "	35 00
" 7½.	48"x22"x22",	110 "	60 00
" 8½.	54"x24"x24",	145 "	95 00
" 9½.	60"x26"x26",	180 "	135 00

All our aquaria are so constructed that water cannot come into contact with the metal.

All sizes and shapes made to order. We charge only actual cost for packing and cases.

FISH FOODS

	Per Tin box.	Per lb.
Natural Fish Food.....	\$.10	\$.50
Universal Fish Food....	.15	2.00
Ground Dried Shrimp..	.10	1.00

	Per Tin box.	Per lb.
Ground Dried Flies and Insects20	3 00
Ground Dried Daphnia.\$.20	\$3.00
Infusoria Creating Food	.15	2.00

Correspondence Solicited. JOSEPH TAUBLES, Manager. No Catalogues

IF YOU

Are Looking for Something Extra
Fine in Broad-tail Telescopes

Don't Forget W. H. HEIMBACH

Breeder and Importer of FINE FISH
Snails Plants

FISH FOR SALE AT ALL TIMES!

413 NORTH TENTH STREET
ALLENTOWN, PA.

MECCO GARAGES
Here is a chance
to make money
Write for Proposition
Give References
— ADDRESS —
M. E. Corrugating Co.
COVINGTON,
KENTUCKY

JOHNNY DARTER

HELEN A. LOOMIS

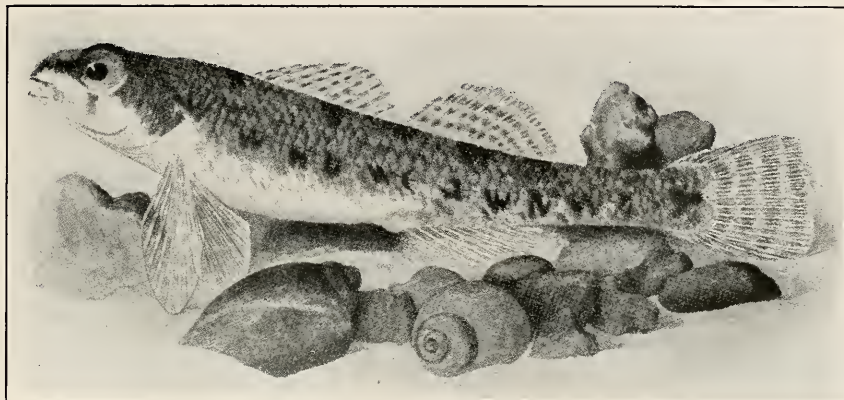

Johnny Darter

Boleosoma nigrum

The admirers of Johnny Darter do not present him as a rival of small tropical aristocrats, but just a fascinating little plebian migrating from the mountain streams. He has neither remarkable beauty of form nor color, but he certainly has "pep." In fact, he is a splendid illustration of the keenness and adaptability with which Nature equips the winners in her own aquaria, where mouths are many and meat is scarce.

Seining along the shallows of our colder lakes or better still, swift brooks and creeks, will procure a quantity of small fishes, consisting of various minnows; babies of our larger food fish, such as perch, bass, suckers, etc.; and almost without fail some of the darters. The latter may be distinguished from their small associates by placing the catch in a shallow pan of water, with a sand layer and observing their activities. They will immediately sink to the bottom and, if disturbed, instead of swim-

ming suspended in the water, will dash across the sand running on the elongate pectoral fins—hence the name darter. Johnny may now be personally identified as follows: Length, two and one-half inches; color, pale straw, with a tinge of olive; markings, the back spotted with dark to resemble the sand, and very distinct M, N or W marks along the side over the lateral line; the two dorsals and caudal fin spotted with brown, forming transverse bands; the eye very large and prominent, with a golden iris.

At home in an aquarium, provided with a plentiful scattering of large pebbles, as well as the sand, he will entertain the observer with some of the following capers. He may go for a ride, suspended on the under side of a floating board if provided, or again he will rest with his body supported by the stones and his head turned at an angle, as if posing. This feat and the ability

to roll his eyes are among his proudest accomplishments. Suddenly he will dance sideways across the tank, much like a kitten after a paper ball, the unsuspecting target being a peaceful snail. One snap of his jaws and the victim is headless, for his teeth are very sharp and his appetite most carnivorous. At other times he appears bashful, and with a few vigorous twists of his tail buries all but his eyes in the sand. But, no matter in what he is engaged his charm is largely his ever evident spirit of mischief.

His seeming preference for the bottom may be explained by the very poor, if any development of his air bladder, which being usually well developed enables other fishes to rise in the water. In his native habitat his food consists of *Chironomus* larvæ and those of gnats and small may-flies, which he hunts assiduously under the stones. In captivity he will thrive nicely on the food used for our small aquaria fish, seemingly quite content with an easy life. The spawning season is from the last of April to the first of June. While spawning the male rides on the back of the female, keeping the pectorals and ventrals in rapid vibration. The eggs are emitted at intervals, the female occasionally raising a cloud of sand, probably to protect them.

The darters stand very high in the flesh scale, belonging to the perch family, and are therefore close relatives of the much larger and better known yellow perch and wall-eyed pike. The little fellows have been aptly described as not dwarfs but concentrated fish. Among the darters we have some really beautiful species, such as the rainbow and Iowa darters. But if Johnny does resemble only a piece of used sand paper, he is always up to scratch.

(The accompanying portrait of

Johnny is reproduced from "The Fishes of Illinois," Forbes and Richardson, by permission of the Illinois State Laboratory of Natural History.—Ed.)

Canned Shrimp a Fish Food

Among aquarists I suppose I am not alone in a fondness for shrimp salad. It is not an infrequent dish upon our table and more often than not the canned article is used. I usually manage to purloin one from the kitchen, wash it carefully, then tie it to a piece of white twine and suspend in the squarium a few inches below the water surface. The tank contains a happy family of many species of exotic fishes that soon prove to love shrimp far better than their custodian, at least if one can judge from their persistency in picking tiny shred after shred from the morsel. This is no small task, and in several hours not more than half a shrimp will be consumed by the hundred or more fishes. When the carcass has been so "trimmed" that there is danger of it breaking into pieces and becoming detached from the twine, I remove it. I commend the practice to my fellow aquarian naturalists.—*John Lee Bennington.*

Nature-Study

Nature study is a pursuit which calls all our faculties into action; it makes us observe, remember, reason and think; it takes us out of stuffy rooms into the open air; it makes us walk, wade, row and even swim; it develops inventive genius, gives us eyes to see interesting things everywhere; it appeals to the sense of beauty, form and color, and, above all, makes us reverent by leading us to look up from Nature to Nature's God.—*Rev. C. A. Hall.*

The Chanchito or Shoat

ERNEST LEITHOLF



The Chanchito

Heros facetum

From the waters of Brazil and the Argentine comes to us *Heros facetum* or *Cichlasoma facetum*, call it what you will, a species well-known to us as an aquarium fish for more than twenty years, one that has "worn well," and in which we have never lost interest by reason of its familiarity. The native Brazilians call it the Chanchito, meaning the shoat or pig, perhaps it may resemble it in a tendency to root up the plants, or because of a fancied similarity to the contour of the "porker."

While the Chanchito may not compete with some of the other cichlidois in the matter of attractive colors, still it is a fascinating fish. Its coat is very change-

able, varying from the usual brownish yellow or gray to one with perpendicular bars of bluish-black. The chameleon-like habit of changing the intensity of the coloration, the blunt head and generous fins, make it a conspicuous member of any collection of fishes. In intelligence it ranks second to none. I have bred them many times, and find the observation of the faithful care of the eggs and fry a never-ending delight.

Give a pair a good-sized aquarium not less than twenty by twelve inches, a temperature of about 70 to 75 degrees Fahrenheit, proper foods, preferably worms and raw scraped beef, and soon male and female will begin to dig, scout

and skirmish about for a suitable place in which to deposit the eggs. When satisfied with the selected location for the nest—generally on the top or side of a stone, which they industriously clean—the female deposits the eggs while the male fertilizes them.

It is now that the wonderful activity is displayed, in which, in my experience, no other fish excels. Never for a moment is the nest left unguarded, alternately male and female take up a position above the eggs, ceaselessly working their fins to keep fresh water constantly circulating about the treasures, and to prevent any accumulation of sediment finding lodging among them. After from four to six days of "watchful waiting" the little pellet-like eggs are transformed into a quivering living mass, the individuals unable to swim, but wriggling vigorously to and fro. At times, during this period, the parents find it necessary to transfer their family to other places. The reason, I assume, is to give the babies a new field in which to forage for passing Infusoria. While these transfers take place both parents are busy as bees, each taking a mouthful of the youngsters, but not at the same time; while one is on the way to the new location, the other is on the way back for more; never for an instant are the youngsters out of the range of a pair of watchful parental eyes. After several days the flock begins to swarm about, the proud parents guarding their issue at all times.

One day when showing such a family, a friend while glancing toward another tank, placed his hand near the surface of the water of the Chanchito aquarium. Mistaking his intentions, one of the parents made a powerful leap to meet the fancied enemy, cleared the rim of the aquarium fully six inches above the water line, and landed five feet below on

the cement floor of the conservatory, fortunately without suffering injury. This acrobatic feat was repeated on several other occasions, each time with the intention of charging some object deemed hostile to their offspring, showing their intense determination to defend them at all costs. Finally, for their own safety, we covered the aquarium.

I have kept the old and young together six or eight weeks without noting any cannibalistic desires on the part of the old ones, only removing the young to give them larger quarters for better development. At times, however, I have had to remove one of the parents within a week or two after the hatching of the eggs because of the development of a family row. The Chanchito is interesting and temperamental, and well worth study.

Sidelights

The *Danio malabaricus* shown at the Pittsburgh Exhibition by Leitholf Brothers were "home raised." Mr. R. J. Macrory won first on *Danio rerio*, his being the largest specimens. Mr. Ernest Leitholf was fortunate in having an egg of the American "Chameleon" hatch in his terrarium during the show. The breeding of his lizard in captivity is most unusual. Mr. Leitholf has prepared an interesting paper on the occurrence, one of the many "good things" in store for future numbers of AQUATIC LIFE.

During the winter months both goldfish and the tropical and native species of fishes will appreciate an occasional oyster. Select a small one, a stewing oyster, run a piece of twine through the hard centre and suspend in the aquarium. When badly torn, or if the fishes cease to nibble, remove it. An oyster a week will be sufficient.



Swamp-Plant Aquaria

C. J. HEEDE

The swamp-plant aquarium, one with plants growing above the water, should find a more general place in the home of the aquarist. It is particularly ornamental, and can be maintained successfully with comparatively little care. While perhaps primarily a tank for plants, it will make a suitable home for fishes and other forms of water life. It would be an ideal home for the paradise fish, or it could be used for sticklebacks; for fry of many fishes; for crustaceans; for insects which pass the early portion of their lives in the water, and later transform to winged inhabitants of the air. Of crustaceans a collection of fresh water shrimp would be interesting indeed. Even *Hydra* would lend itself to observation to an advantage, especially with regard to its foods and habits of feeding. Some of the newts or salamanders, and diverse species of snails, could profitably be given a home. Of course, all the forms mentioned could not be wisely associated in the same tank; judgment based on the habits would have to be used. Much original research work could be pursued in such an aquarium, particularly among the insects; the life-histories of many are still imperfectly understood.

To arrange a tank for swamp plants, a six-inch layer of leaf-mould, loam and sand, mixed with some fertilizer, such as dried and powdered blood, or sheep manure, is necessary, as these plants are gross feeders. To prevent the discoloration of the water by the agitation of the bottom by the moving life of the

tank, an inch layer of gravel and sand should be laid on top of it. The water should be twelve inches deep if submerged plants, as well as those with aerial leaves are to be used.

Plants should be selected from among



A Swamp Aquarium
From "Stuekkulturer"

those that will grow and thrive throughout the year—tropical species, or those that do not require the winter rest of those of the temperate zone. An attractive collection can be selected from the following list: *Sagittaria montevidensis*, white flowers, brown spotted; *S. lancifolia*, lance-shaped leaves, white flowers; *S. graminea*, grass-leaved, white flowers; *S. japonica*, white flowers; *Saururus lucidus*, bush-like, heart-shaped leaves; *Cyperus gracilis*, low growth;

Cyperus papyrus, tall; Swamp iris, sundry kinds and colors. Plants growing above the water but decumbent—trailing over the sides of the tank: *Myriophyllum preserpinaoides*, Parrot's Feather, beautiful greenish-blue spruce-like foliage, which closes at night and reopens in the morning; *Lysimachia nummularia*, common moneywort; *Lud-*

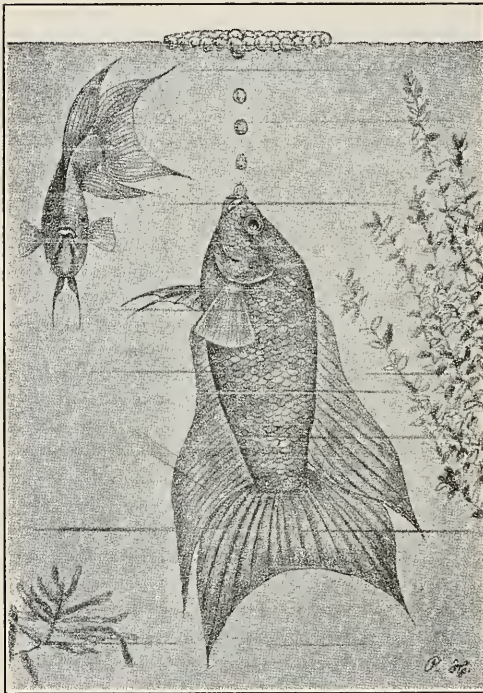

Male Paradise Fish Building Nest

wigia mullerti, too well-known to need comment. Submerged plants: *Sagittaria*, fine-leaved species; *Vallisneria spiralis*; *Heteranthera zosterifolia*, lilac colored flowers born above water; *Isoetes*, various species; *Cryptocoryne griffithi*, red flowers above water; *Fontinalis gracilis*. Plants to float upon the water; *Riccia fluitans*, floating liverwort; *Salvinia natans*, a fernwort; *Pistia stratiotes*, water lettuce; *Ceratopteris thalictroides*, the water-fern.

The over-water plants, those thrusting their leaves above the water, should be sprinkled frequently to remove the dust.

A rubber sprinkler should be used holding the stems together to prevent the water falling beyond the limits of the tank. In this way, too, water lost by evaporation is replaced. Swamp plants take up great quantities of water, especially when accorded the abundant sunshine which they need to flourish.

I am well aware that many swamp plant aquaria have been established, and have been failures. Usually this is due to poor, shallow soil, lack of abundant sunshine, and neglect to sprinkle the plants. Plants other than those which grow submerged breathe through stomata or pores usually to be found most abundantly on the under sides of the leaves, but also on the upper. If these pores are clogged with dust the plant cannot flourish.

The appropriateness of the swamp plant aquarium in the living room has been questioned, but if arranged and maintained properly, it will be as sanitary as that with only submerged plants and fishes, and will be much more beautiful and interesting.

As the high honor in contests of aquaria and fishes it has become the custom to award a silver cup. It makes quite a pretentious prize at a slight expense; a good-sized cup can be bought for a few dollars. Having no utilitarian value, the novelty of exhibiting the prize sooner or later wears off, and it goes into the discard. Would it not be better if articles of serviceable kind were used instead of the cup? Among many other things a silver bread tray suggests itself, and has the advantage of a large surface on which to engrave a suitable inscription. This would make a very desirable prize, and could be used on the table of the winner every day in the year. It will not be hard to compile a lengthy list of articles, all of them of a more practical nature to the winner than the hackneyed silver-plated cup.—*Aqua-Pet*.

AQUARIUM NOTES

N. M. GRIER

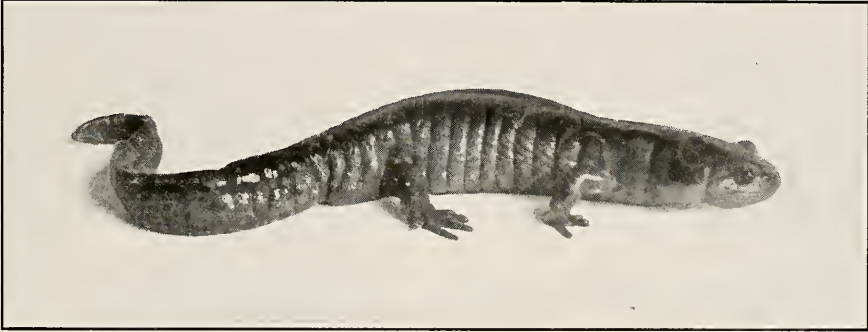

The Spotted Salamander *Amblystoma punctatum* Photograph from Life by Dr. R. W. Shufeldt

Among the little used plants which thrive in aquaria, especially if well anchored, are the native species of arrowhead, *Sagittaria* (lakes and ponds), and the somewhat rare water fernwort *Marsilia*, having a four-leaf clover aspect. The latter is best secured from conservatories. The closely related *Salvinia*, similarly obtained, rarely thrives in the small aquarium, and gradually dies out unless accorded warmth and sunlight. *Elodea* or *Anacharis*, the common water weed, and a widely used plant in aquaria, has been known to cause the death of snails living in water in which it grows, although in the writer's experience it is apparently harmless to other forms of animal life. *Lemna*, known as "Duckmeat," will thrive best under fairly sunny conditions, and is interesting in that it frequently bears on its under surface the siliceous cases of certain minute worms, which may often be seen to emerge from their home and seize animalcules.

The larger species of Algae as a rule will only flourish when so entangled with

the stems of other plants that the fish find it difficult to penetrate. Of this class of plants, the use of two in aquaria, the stoneworts *Nitella* and *Chara*, should be more generally known. These plants consist of a stem-like body with leaf-like divisions in whorls at regular intervals, and have a decidedly rough feeling when drawn through the hand. Although they are found in streams containing a good deal of lime, they grow well upon a sandy bottom. *Isoetes*, a botanical curiosity, found in lakes and rivers, will live in the aquarium with a gravel bottom, as well as the common water-moss, *Fontinalis*, found along brooks.

An animal little known to aquaria, and which will at least exist for some time therein, is *Spongilla*, the fresh water sponge. It is, however, an aquatic delicacy, and should be protected by massing the plants around it. It is found in clear running brooks in circular, concave, slightly rough masses of a greenish tinge attached to stones or water plants. Certain forms of colonial PROTOZOA

(*Opercularia*), when introduced on water plants will live indefinitely in aquaria, appearing as many thread-like masses covering the vegetation. Their points of interest, however, are best discovered with a microscope.

Hydra, the water polyp, a tube-like animal with tentacles, in structure allied to the sea anemones, when it has been introduced will grow widely over the



Marsilia or Water Clover

entire aquarium for a great length of time, and when it does disappear may be looked for later. Its movements during the capture and digestion of small animalcules are interesting. Mature goldfish seldom harm them, due to their stinging properties, and to the fact that they may contract into small jelly-like masses, difficult to remove from the walls of the aquarium. In a tank containing fry of goldfish they are as a scourge, killing all that come in contact with the tentacles. Both the freshwater sponge and *Hydra* grow well on *Elodea*. For those who teach zoology a hydra aquarium is of great value.

An excellent natural food for fishes

is found in the small Crustacea which rapidly appear in stagnating water, or water to which decaying plant remains are added, and then covered. They may thus be grown as desired, and later given to the fishes. Most of the fresh water snails, *Physa* and *Lymnaea*, and particularly the latter, while doing well in the aquarium, will, if their numbers are unchecked, consume the vegetation.

Forms of animal life which have not received much attention, and which are well worth a trial in aquaria are the freshwater mussels, which are found in a great many gravel-bottomed, unpolluted streams. Among the species best adapted to aquarium life are the Big Blue Point (*Amblema variplicata*), Monkey Face (*Quadrula*), and Heel-splitter (*Lastena suborbiculata*). They will survive only when the size of the aquarium is such that extensive aeration takes place. Their movements will interest all—the protrusion of the curious foot from the shell for locomotion, and of the tube-like syphon for the purpose of drawing in the food and air-bearing water.

An animal holding its own in aquaria, and of interest on account of its outside gills while in the immature stage, is the salamander (*Amblystoma*), secured along brooks and in ponds. It is, however, apt to depopulate the aquarium of its smaller inhabitants.

The extremely thin surface layer of water in contact with the air acquires physical properties comparable to those of a fine membrane. This is demonstrated when a quantity of *Daphne* is placed in an aquarium. Unless the water is agitated some will be entangled in the film, and, unable to descend, will perish. If one from below should swim too close to the surface, it too will become entangled, float above water, and meet a like fate. It is this film that enables one to float a needle.

Minute Inhabitants of Aquaria

PERRY BRUCE CLARK

San Francisco Aquarium Society

An infusorian of interest is the *Vorticella*, or bell animalcule. This little animal is found attached to aquatic plants, generally in old water, sometimes appearing like a fine white fringe. As the name implies, it is bell-shaped, and it attaches itself to a solid object by a long, slender, flexible stalk. This stalk contains a long muscle fiber, and when the *Vorticella* becomes disturbed, the stalk, by means of the fiber, is coiled with a

in the same manner as in *Paramecium*. At the outer end of the gullet is a space called the vestibule, and into this is passed any undigested residue, which is swept out by the outgoing currents of water maintained by the cilia. There is also a contractile vacuole near the vestibule, which empties into it. It has a C-shaped nucleus. *Vorticella* multiplies by longitudinal division. Sometimes a number of these infusoria are found in a group where they have multiplied and stayed together, but generally after multiplication has occurred the different individuals separate and move to other places, where they may have a better chance to obtain their food.

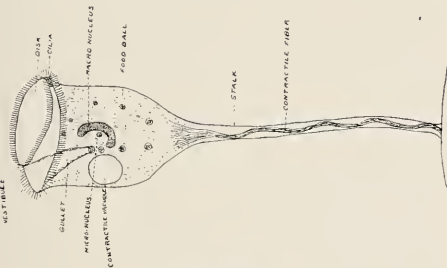

Vorticella

jerk, the movement pulling the animal close to the object to which it is attached. When everything is quiet again the stalk gradually relaxes and the little animalcule once more reaches out in search of food. The bell-shaped body is not hollow, but is composed of protoplasm. Across the mouth of the bell is a disk, which is slightly smaller than the mouth, leaving a space for the opening of the gullet. Both around the mouth and the disk are placed a row of cilia, which constantly vibrate to and fro, setting up currents in the surrounding water, which bring small particles of food to the gullet. This food, which is composed of minute plants and animals and fragments of larger forms, collects at the bottom of the gullet, forming a food ball

We will now proceed to the METAZOA, or many-celled animals, one of the lowest of these which is of interest to us is the fresh-water polyp, or Hydra. These little animals, which are generally found attached to aquatic plants, have a cylindric body about half an inch long, and the thickness of a pin, and are generally colorless, but sometimes brown or green. At the free end are a number of fine, thread-like tentacles, which gently sway to and fro. If the Hydra is disturbed these tentacles are quickly drawn in and the whole body contracts until it is nothing more than a small ball. The mouth is at the free end in the centre of the tentacles. The body is hollow and is composed of two layers of cells, the outer layer serving as a protective covering and the inner layer digesting the food that is taken in. In the process of evolution this is one of the first examples of the division of labor among cells.

Aquatic Life

A monthly magazine devoted to the study, care and breeding of native, tropical, gold and fancy fishes, other animals and plants in the household aquarium.

W. A. POYSER Editor
 JOSEPH E. BAUSMAN Publisher
 542 E. Girard Avenue, Philadelphia

Entered as second-class matter, September 2, 1915, at the Post Office, Philadelphia, Pa., under Act of March 3, 1879.

Yearly Subscription \$1.00
 Foreign Subscriptions 1.35
 Single Copy 10 cents

Payments may be made by express money order, draft, post office order or registered letter. Foreign remittances should be by international money order.

Advertising rates made known on application.

"Aquatic Life" is the only magazine in America devoted exclusively to aquatic life, and its value as an advertising medium in this field of nature study is unequaled.

Copyright 1917 by Joseph E. Bausman

Vol. II January, 1917 No. 5

Among the cells of the outer layer, both on the body and the tentacles, are numerous stinging or thread cells; these resemble somewhat those of *Paramecium*, but are of a more highly organized nature. The threads are discharged whenever the animal is irritated, and are also used for obtaining food, for when a cyclops or other small animal comes in contact with the Hydra it is paralyzed by the discharge of one of these stinging cells, and is then drawn into the mouth by the tentacles. The Hydra attaches itself to an object by secreting a sticky substance from the cells of its base. It rarely moves about, but may do so by holding on with the tentacles and moving the base.

It multiplies either by budding, which is simply a process of a new hydra

growing out of the side of the old one, or by the production and fertilization of eggs, the body containing both an ovary and a spermary.

The planarian worm is another form of life generally found in old standing water, especially that into which plants have been introduced from outside sources. It resembles a leech in general appearance, but is very much smaller, rarely exceeding an eighth of

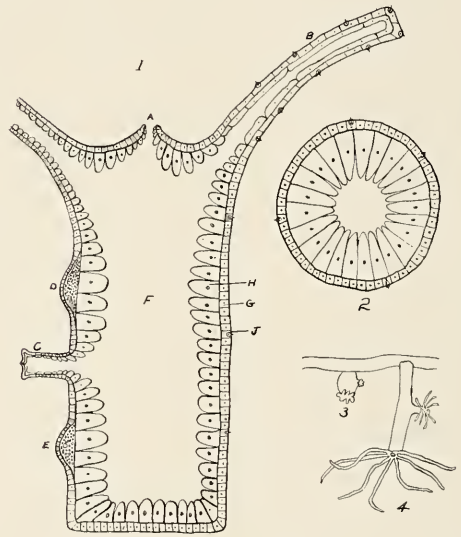

Hydra

1. Lengthwise section of body, showing: A, mouth; B, tentacle; C, reproductive bud; D, spermary; E, ovary; F, body cavity; G, ectoderm (outer layer of cells); H, entoderm (inner layer of cells); J, stinging cell. 2. Section across body. 3. Mature Hydra contracted. 4. Same extended. (Figures 1 and 2 greatly magnified; 3 and 4 slightly enlarged).

an inch in length. It is soft and jelly-like, of a grayish color, and changes its shape very readily. The most striking characteristic is that it is extremely cross-eyed, presenting a very queer appearance when viewed under the microscope. It is sometimes found attached to fishes and the tenacity with which it holds on is surprising.

Knickerbocker News

A number of members of the Aquarium Society, New York City, who converse in the German language, have organized a section that will hold monthly meetings on the first Tuesday at The American Museum of Natural History. Dr. E. Bade is presiding officer.

It should be patent to every one that the step taken by these aquarists was in every way preferable to the organization of a distinct society. It is customary in all institutions to organize subsidiary sections, branches or departments, each caring for the interests of those specializing in a particular study. Such sections enjoy the resources of the parent organization and unite in actions for common welfare, yet maintaining individuality necessary for specialization. Organization along these lines is especially adaptable to aquarium societies, some members of which may devote themselves entirely to exotic and native fishes, and others to goldfish breeding, one class having no interest in the other. Rather than split such a society into two weaker ones, sections for each class should be formed. The meetings would be devoted to the object of the individual section, and programs arranged accordingly, but members of other classes could attend.

The Word "Aquarium"

Years ago when the principles of the aquarium first became known, and its popularity began to grow, there were grand etymological discourses in the learned papers respecting the correct name which ought to be given to it. Some called it vivarium, but were met by objectors who said the zoological garden was equally a vivarium, and so was a dog kennel or a stable. In order to meet the difficulty, they proposed the

word aqua-vivarium—a word which certainly had the advantage of being correct, but the disadvantage of being complicated. Then came others who preferred the name aquarium, and straightway this name was adopted by common consent. It is true that exact linguists rejected the word, citing the Latin dictionary, which stated that *Aquarius* was either a water-bailiff or a water-man, or "the man who carries the water pot" in the Zodiac. Still aquarium is a simple and easy word, and entirely superseded aqua-vivarium, just as in a later year the word telegram superseded telegrapheme.—*Rev. J. G. Wood.*

Wagner on Light Control

In the November number of "Aquatic Life" I note that a Los Angeles reader

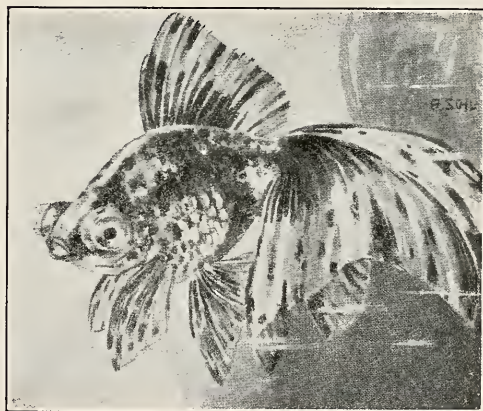

A German Conception of the Broad-tail Calico Telescope Goldfish

is having difficulty with his aquarium because of the intense heat and light. If he will remove the clear glass from the lower portion of the window sash, replacing it with ground glass, he will get wonderful results. Or, if he will fasten a piece of ground glass against the window pane, sufficient to diffuse all the light coming through the window to the aquarium, he will get the same

results. I do not advocate placing the ground glass against the aquarium, which will not give as good results as placing it against the window pane. I have experimented with this plan for a long time, and have found it to give wonderful results, even in this climate (Washington, D. C.), as it cuts off the direct rays of the sun, which promote the growth of Algæ. It passes enough light for the plants to grow and maintain their natural brilliant green color, instead of turning yellow, transparent or brown, as too much light has a tendency to cause.—*J. Henri Wagner.*

My "Faulty Techniques"

JACOB MERGET

In the June, 1916, number of "Aquatic Life" appears an article by the present writer concerning the hybridization of fishes, in which was explained the method followed to accomplish the cross. Subsequent to this I began to lose interest in further experiments. I had seven hybrids—two males and five females. Of those a friend in Chicago received four, and for myself, in spite of my waning interest, I reserved one male and two females. The mother of these fish, a female *Xiphophorus helleri*, I lost, together with a female *Girardinus guppyi*, which I had bred to a male of *X. helleri*, receiving from it a lot of weaklings that did not survive a week.

More than once I had been told that these hybrids would be sterile and incapable of reproduction. It was this opinion, more than anything else, that denuded the hybrids of their earlier charm. My surprise can be imagined when, on day in August, I discovered that one of the hybrid females was pregnant. I promptly made arrangements for the delivery. Ten days later the young were expelled, seventeen of them, and not a bad beginning. Twelve of

these survived and are strong and healthy; five died, being so weak at birth that they did not rise from the bottom of the aquarium. In the meantime the male made love to the other female, and at the present writing she shows signs of pregnancy. The coloration of the young is the same as that of the hybrid parents; lower portion of the body black, upper portion red with black spots. Whether they will have the sword-like extension of the caudal fin is problematical.

In view of the unanimous doubt that was cast upon the possibility of the fertility of the original hybrids, I have named the youngsters "Faulty Techniques."

Philadelphia Goldfish Fanciers

The December meeting was held Wednesday evening, the 21st, in Saull's Hall, 804 West Girard avenue.

EXHIBITION: Lionheads, Orandas and Celestial Telescopes.

JUDGES: Joseph E. Van Stavern, George W. Price and R. L. Harding.

AWARDS: *Orandas*, silver cup and blue ribbon, A. A. Phillips, Jr.; red and yellow ribbons, J. Martin Wacker. *Celestial Telescopes*, blue, red and yellow ribbons, A. A. Phillips, Jr. *Lionheads*, silver cup and blue ribbon, Fred Schaefer; red ribbon, Mrs. Elizabeth Ahlers; yellow ribbon, Joseph E. Tyler.

Messrs. Edwin R. Keck, Joseph Wheatcroft and Edward R. Stembach were elected to membership.

The next regular meeting will be held January 17th. The regular competition will be for nymphs and single-tail telescopes, scaled and scaleless, three ribbons to be awarded in each class. At this meeting there will also be a competition for scaleless telescopes bred in 1916, to the winner of which will be awarded the cup presented by Charles E. Visel.—*Fred Richardson, Secretary.*

Reading Public Exhibition

G. S. BRENEISER

The members of the Reading Aquarium Society are congratulating themselves upon the success, and no less the appreciation of the general public, that attended their aquarium exhibition given in conjunction with the Flower Show. The aquaria seemed to attract more attention than the beautiful flowers, and many times difficulty was experienced to keep the crowd moving that all might have an opportunity to view the tanks.

The following members exhibited aquaria and fishes: Mr. William H. Heimbach, of Allentown; Messrs. John Kershner, William Himmerschitz, Irvin Yeager, Ralph Wilson, Philip Weiler, O. H. Mellertt, Theodore Abeling, George Becker and George S. Breneiser, all of Reading.

The Pittsburgh Show

E. W. HARPER

The exhibition of the Pittsburgh Aquarium Society was held in Phipps Conservatory, November 11th to 19th, inclusive. The average Sunday attendance was 15,000. Nearly one hundred and fifty aquaria were shown (not bad for a first exhibition), containing fishes, both gold, exotic and native species, too numerous to count. Dr. Cruickshank was "General Superintendent" and worked hard to make it the success it was. The exhibition was competitive. Messrs. Leitholf and Winters, judges, made awards as follows:

GOLDFISH BREEDS: *Scaleless Telescope*, A. Stucky; *Fantail*, D. Winter; *Comet*, G. W. Sanders; *Common Goldfish*, Phipps Conservatory.

EXOTIC FISHES: Awards, all firsts, to Leitholf Brothers, R. J. Macrory, D. Winter, Dr. L. M. Kearns, E. W. Harper, A. A. Allen, G. W. Sanders, H. Dolde and G. A. Smith.

NATIVE WILD FISHES: First to Dr. O. T. Cruickshank.

SPECIAL PRIZES: *Miniature Aquarium*, G. W. Sanders; *Most Artistic Aquarium*, D. Winter; *Aquarium Op-*

erated by Electric Light, Dr. L. M. Kearns; *Aquarium Showing Breeding Mosquitoes*, Dr. O. T. Cruickshank; *Terrarium*, Ernest Leitholf.

Special Goldfish Number

Following the precedent established by the March, 1916, number of "Aquatic Life," the March number of the present year will be devoted almost entirely to the breeding of goldfish and kindred subjects. Last year the "Goldfish Special" was exhausted within a week after its publication, and many were unable to secure a copy. Those who purchase from the local pet shop should place their order early, and the dealer should anticipate the demand, requesting the needed additional copies from the publisher well in advance of publication.

The value of this special number from an advertising standpoint will be exceptional, not only to the breeder of goldfish, but also to the tropical fish fancier, due to its larger circulation among those who do not ordinarily read the magazine. If only for pure publicity, it should contain the advertisement of every breeder who will have fishes and supplies for sale during the succeeding months of spring and summer. It is quite possible that this number will contain a greater number of pages and more illustrations than usual. Space should be reserved and copy for advertisements sent at once.

Boston News

The December meeting of the Boston Aquarium Society was held Friday evening, the 8th, at the Boston Museum of Natural History.

It was decided to hold the first public exhibition in conjunction with the Boston Poultry Show, January 10th to 13th, inclusive. No awards will be made. The object of the exhibition is purely to attract new members. Messrs. Blodgett, Packard, Jones and Coffin were elected a "Show Committee" —Walter H. Chute, Secretary.

EXTRAORDINARY LIMITED OFFER TO AQUATIC LIFE READERS

By special agreement, we have arranged a remarkable money-saving introductory campaign through which our readers may

obtain Aquatic Life in club with splendid periodicals for the home, for only a fraction of their real value.

The Publishers Will Mail the Magazine Direct From Their Own Office to You

To take advantage of this remarkable opportunity you should act at once, as the offers are good for a limited time only. Present subscribers to any of these magazines may have their subscriptions extended.

The magazines may be sent to one address or each to a different address. This gives you an opportunity to have your

friends subscribe with you or to use the magazine subscriptions as gifts to your friends or relatives. Each subscription is for one year. Extra postage is necessary on Canadian and foreign subscriptions.

Remit by money order, check, United States stamps or currency, as most convenient. Please use the coupon below.

Aquatic Life	\$1.00	} OUR PRICE
American or Every-	1.50	
body's	1.50	
Regular Price	\$2.50	\$2.00

Aquatic Life	\$1.00	} OUR PRICE
Everyland or Boys'	1.00	
Magazine	1.00	
Regular Price ..	\$2.00	1.50

Aquatic Life	\$1.00	} OUR PRICE
Gardening or Chris-	2.00	
tian Herald	2.00	
Regular Price	\$3.00	2.00

Aquatic Life	\$1.00	} OUR PRICE
Housewife and To-	1.00	
days	1.00	
Regular Price ..	\$2.00	1.50

Aquatic Life	\$1.00	} OUR PRICE
McCall's and De-	1.50	
signer	1.50	
Regular Price	\$2.50	2.00

Aquatic Life	\$1.00	} OUR PRICE
Ladies' World and	2.00	
Every Week	2.00	
Regular Price	\$3.00	2.50

Aquatic Life	\$1.00	} OUR PRICE
Table Talk, The Na-	1.00	
tional Food Maga-	1.00	
zine	1.00	1.50
Regular Price	\$2.00	

Aquatic Life	\$1.00	} OUR PRICE
Something to Do (for	1.00	
Children)	1.00	
Regular Price	\$2.00	\$1.50

Aquatic Life	\$1.00	} OUR PRICE
Musician or Parisi-	1.50	
enne	1.50	
Regular Price	\$2.50	2.00

Aquatic Life	\$1.00	} OUR PRICE
Short Stories or	1.50	
Young's	1.50	
Regular Price	\$2.50	2.00

Aquatic Life	\$1.00	} OUR PRICE
Everybody's	1.50	
Delicater	1.50	
Regular Price	\$4.00	3.00

Aquatic Life	\$1.00	} OUR PRICE
Ladies' World	1.00	
Mother's Magazine ..	1.50	
Regular Price	\$3.50	2.50

Aquatic Life	\$1.00	} OUR PRICE
Field and Stream ..	1.50	
Regular Price	\$2.50	
		2.00

Aquatic Life	\$1.00	} OUR PRICE
Pictorial Review	1.50	
Popular Science	1.50	
Monthly	1.50	3.00
Regular Price	\$4.00	

AQUATIC LIFE

542 E. Girard Avenue, Philadelphia

Enclosed find \$_____ for which please send the magazines mentioned opposite, to the addresses indicated, each for a full year.

Name of sender

Street address

Town

Date..... State.....

SendMagazine to

Name

Address

SendMagazine to

Name

Address

Magazines Make Excellent Gifts

Books for Aquarists



The Home Aquarium and How to Care for It. A guide to its fishes, other animals and plants. By Eugene Smith. 213 pages, 137 illustrations, cloth binding, \$1.20. Add parcel postage on two pounds.



Goldfish and Its Culture. Practical instructions for pond breeding, shipping, care of the aquarium, and the general subject. By Hugo Mullertt. 155 pages, 15 illustrations, cloth binding. \$2.00. Add parcel postage on two pounds.



Fish Culture in Ponds and Inland Waters. The most recent book, covering the propagation of goldfish, food and game fishes, and aquarium management. By William E. Mehan, Director of the Fairmount Park Public Aquarium, Philadelphia, and former Pennsylvania State Fish Commissioner. 287 pages, 22 illustrations, cloth binding. \$1.00. Add parcel postage on one pound.



Japanese Goldfish. A guide to the Japanese methods of culture. By Dr. Hugh M. Smith, U. S. Commissioner of Fisheries. 10 full-page colored plates, numerous text cuts, 112 pages, cloth binding. \$2.00. Add parcel postage on two pounds.



Life of Inland Waters. Needham and Lloyd. A big book containing 438 pages and 244 splendid illustrations. It presents a survey of the whole realm of freshwater aquatic life. The only American publication on the subject, and one that will materially assist the aquarist in solving the many problems encountered. \$3.00. Add parcel postage on three pounds.



The Freshwater Aquarium and Its Inhabitants. A practical work for the aquarist. By Egging and Ehrenberg. Freely illustrated. 352 pages, art cloth binding. \$2.00. Add parcel postage on two pounds.



Address **AQUATIC LIFE**

Book Department

542 East Girard Avenue, Philadelphia

New & Direct Importation

of

Tropical Fish

From South America

MANY SPECIES QUITE NEW

Address

GENERAL SCIENTIFIC COMPANY

Corner 10th Avenue and 206th Street

New York City

N. B. GOLDFISH FANCIERS!
LOOK! Get your names on our list
for very special announcement.

CASH FOR MANUSCRIPTS

OF INTEREST TO AQUARISTS

Write Me Fully in First Letter

ADDRESS, ALBERT G. GEIGER

142 N. Collington Ave., Baltimore, Md.

THE AQUARIUM WORLD

Is a Section of "THE PET STOCK WORLD"

It's Slogan "FOR MORE PUBLICITY TO

THE AQUARIUM WORLD'S INHABITANTS"

Trial, 3 Months 10c 6 Months 25c Yearly 50c

Pet Stock World, 652 N. Chester, Baltimore, Md

AQUARIUM STOCK CO.

150 Chambers Street :: New York City

Aquarium Specialists

GOLDFISH, FOODS, PLANTS, SNAILS, ETC.

Combination Natural Fish Food - Sample Can 10c

Imported Shrimp Fish Food - - Sample Can 15c

Imported Wafer Fish Food Large Sample Box 10c

Special Prices on Quantity Lots Cash With Order

Catalogue Sent Upon Request

ORDERS AMOUNTING \$2 DELIVERED POSTPAID

Mail Orders Promptly Attended To

Aquatic Life

Aquatic Life. Volume One. America's aquarian naturalists have collaborated to make "Aquatic Life" a practical cyclopaedia for the aquarist. The first volume, 166 pages, is complete. Every essential phase of this fascinating branch of nature-study is treated; special articles, splendidly illustrated, cover goldfish breeding, native and exotic species; the care of the aquarium, and the general subject. The illustrations, more than one hundred, some in color, include the finest that have ever been published of the various goldfish breeds. "Aquatic Life" is conceded the best illustrated aquarists' magazine in the world. The volume costs two dollars, postage prepaid.

Address Aquatic Life

(Book Department)

542 East Girard Avenue, Philadelphia

EDWARD S. SCHMID

Emporium of Pets

ALL KINDS OF GOLDFISHES AND AQUATIC PLANTS AND WATER LILIES

712 Twelfth Street, N. W., Washington, D. C.

Taxidermy

Send for Catalog

DRIED SHRIMP - (Ground 75c per Pound)

Postpaid

Special Price on Quantity Lots

My Natural Fish Food Sample can 15c Per Pound \$1.00

CANADIAN BIRD STORE

2139 W. Van Buren Street

Chicago, Ill.

ONCE YOU TRY, YOU ALWAYS BUY

Gnadt's Perfect Fish Food, 10c box

Pulverized or Whole Shrimp, 7 c. lb.

BREEDER OF FANCY GOLD AND TROPICAL FISHES

Manufacturer of all kinds of aquariums

Fish nets made of finest netting, 15c.

Great reduction by dozen or gross.

BROADWAY BIRD STORE

P. F. GNADT, Proprietor

1632 Broadway Greenhouse, 1630 Broadway

BROOKLYN, N. Y.

HALLER'S

Hartz Mountain Bird Store

Wholesale and Retail Importer and Dealer in

Genuine Hartz Mountain & St. Andreasburg

CANARIES

Gold Fish, Globes, Pigeons, Pet Dogs, Dog
Medicine, Poultry Supplies

Full Line of Best Imported German Bird Seeds Always on Hand

1108 VINE STREET

CINCINNATI, OHIO

R. PEGLOW

Dealer and Breeder of Fancy Goldfish

Broad-tail Telescopes My Specialty

All Kinds of Aquaria and Supplies

557 WOODWARD, AVE., BROOKLYN, N. Y.

To Prevent Many Fish Diseases

USE REGENIA AQUARIUM SALTS

To replace natural salts in waters
as absorbed by fish and snails

6 POWDERS IN BOX, 25 CENTS

Regenia Chemical Co., Sta. K, Philadelphia

ENCHYTRAE

The Secret of Successful Breeding of Tropical
Fishes and the Ideal Live Fish Food.

Portion, 50c (cash or money order) with Instructions how to breed them

CHARLES E. JENNE

109 22nd Street West New York, N. J.



Raw beef contains 16 per cent Protein. Boil it and you will see a white scum form on top of the water. This scum is the Protein escaping from the beef and is the real nourishment which is lost. There are no nutritious elements lost in making Yogi its all food made by a new method.

Robert J. Schaeffer

1818 Frankford Ave., Phila. Sample 10c

"AQUARIA FISH"

A practical work on care and breeding of fish in the Aquarium, Greenhouse and outdoor Ponds. Finely illustrated. Every one interested in keeping fish should send for a copy of this book. Price, \$1.

Four-Horned Snails (Ampullaria Gigas) deposit a mass of large coral red eggs out of the water, the little snails drop into the water as they hatch. These snails are invaluable for destroying Hydra in the aquarium.

Thoroughbred Collie Pups, beautifully marked.

F. L. TAPPAN

92 S. 7th Street, Minneapolis, Minn.

WALTER BELL

Breeder of **Broad-tail Telescopes**

BLUES BLACKS CALICOS

4324 WYALUSING AVENUE, PHILADELPHIA

Prices Reasonable

THE TERMINAL PET SHOP

PETS OF EVERY DESCRIPTION AND KIND

Manufacturing and Maintenance of Aquariums a Specialty

All Kinds of Cat and Dog Foods and Medicines

HUDSON TERMINAL BUILDING

Concourse, New York

TEN VARIETIES OF BEAUTIFUL AQUARIUM PLANTS

for \$1.00 Postage Postpaid

J. HENRI WAGNER, 1909 North Capitol
Washington, D. C.

VIOLET RAY FISH REMEDY

Relieves Constipation, Fungus, Tail Rot,
Congestion. Safe and effective. **Box of six
powders 25c.** For sale at Pet Stock Stores,
or address

REGENIA CHEMICAL CO., Sta. K, Philadelphia

“Everything is Fish that comes to the Net of a Naturalist”

Don't paddle in the water with one
hand and be blind with both eyes. In
other words, “keep your eyes open” for
all nature.

OUR MAGAZINE

The Guide to Nature

WILL HELP YOU

It is edited by EDWARD F. BIGELOW, who
fishes in the heavens and earth, as well
as the waters under the earth.

Single copy, 10c.

Four months' trial, 25c.

One year, \$1.00.

THE AGASSIZ ASSOCIATION

ArcAdIA

Sound Beach

Connecticut

Beginners!

TAKE SPECIAL NOTICE!

Rare Tropical Fish Very Cheap



(Also *New Fish* from Venezuela)



Owing to unprecedented success this
season in breeding some of the rarest
tropical fishes, I am able to offer them,
while they last, at unheard-of prices.
This includes many species now impos-
sible to import on account of the war.
You can learn ALL ABOUT THESE
FISH in my BOOK—“DOMESTI-
CATED FISH.” Price, \$2.60, postpaid,
direct from the author, W. L. BRIND,
F. Z. S., 449 West 206th Street, New
York City. N. B. Telephone, St.
Nicholas 8418. Ring me up before call-
ing, or write.

Broad-tail Telescopes

Correspondence Solicited

GEORGE WILT, 1519 N. 62d Street

PHILADELPHIA

Thomas Ayling

FINE BROAD-TAIL TELESCOPES

Some Nice Young and Breeders at Reasonable Prices

845 East Ontario Street :: Philadelphia

THE BRUCE FISHERIES

Breeder, Importer, Wholesale & Retail Dealer in

All Kinds of Goldfish

Comets a Specialty

ELGIN K. BRUCE, THORNBURG, IA.

FRANKLIN BARRETT

EVERYTHING COMPLETE FOR THE
AQUARIUM, POND AND LAKE

Wyoming Avenue, & C Street, Phila., Pa.

SEND FOR PRICE LISTS

Aquariums of Artistic Designs

Strongly Built, Suitable for the Home, Conservatory, College or Store

Also all aquarium supplies. We make any size aquarium to order, slate or iron-bottom. Write your wants. Dealers with card write for lowest wholesale prices on globes, food and plants.

WE HAVE FOR SALE

Used Little Wonder pump, 25-gallon tank, gauge and regulation valve. Price \$15.00.

Address **PIONEER AQUARIUM CO.**

Racine, Wisconsin.

HERMAN RABENAU, Aquarist

PERMANENT DISPLAY OF

Aquatic Life and Terraria

must be seen to be appreciated

Visitors Welcome

Plants and Tropical Fish a Specialty

Importations of New Varieties received regularly

1163 Myrtle Avenue, Brooklyn, N. Y.
Near Broadway.

Nippon Goldfish Co.

1749 Buchanan Street, San Francisco, Cal.

Importers : and : Dealers

JAPANESE GOLDFISH

DIRECT FROM BREEDERS IN JAPAN

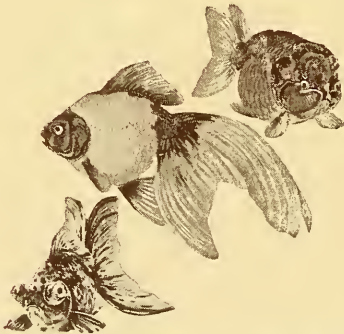

AWARDED GOLD & SILVER MEDALS

Panama-Pacific International Exposition
San Francisco, 1915

ALL KINDS OF AQUARIA AND SUPPLIES

Price Lists Furnished to the Trade Only

HARRY P. PETERS

1210 N. Warnock Street, Philadelphia, Pa

BREEDER AND IMPORTER

Rare and Fancy Fish

Plants of every variety, Snails and Aquarium Supplies of all kinds at all times.

MANUFACTURER OF

Green River Fish Food

10c a Box

Green River Baby Fish Food

15c a Box

A GOOD FISH FOOD is one of the most essential things necessary to keep fish in good health. After the test of years Green River stands out as the best food on the market. It keeps the fish in good color by promoting a healthy, robust growth. It will not sour or cloud the water. Ask your dealer or send for it today.

Young Veil-tail Goldfish

\$ 5.00 per Dozen and Up

A Splendid Assortment of Breeders

\$ 1.75 Each and Upwards

SHIPPING CAN, 25c EXTRA

HARRY P. PETERS, 1210 N. Warnock St.

Philadelphia

Otto Walter

86 Suydam Street :: Brooklyn, N. Y.

Near Evergreen Avenue L Station

Breeder and Importer of

TROPICAL AND GOLDFISHES

Telescopes Calicos Japs Fan-tails

Dealer in All Varieties of Aquatic Plants

All Kinds of Fish Foods

Fresh and Dried Daphnia

AQUARIA, UTENSILS AND SUPPLIES

February, 1917

10c Copy

Aquatic Life



J.H. Goodby
Mil. 1916.

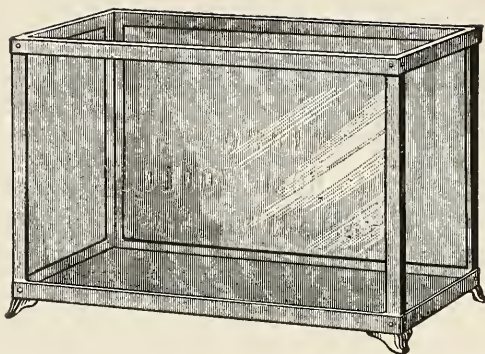

Jacob C. Cassel

915 Arch Street, Philadelphia, Pa

Manufacturer of

AQUARIUMS

Aquarium Ornaments

Floral Terra Cotta, Etc.

Goldfish

Fish Globes

Fish Food

and all aquarium requisites.

Send for Catalog.

Aquarium Specialty Co. 1873 WASHINGTON AVENUE NEW YORK CITY

MANUFACTURERS OF AQUARIA, FOUNTAINS, TERRARIA, VIVARIA

BREEDERS OF DOMESTICATED FISHES

IMPORTERS OF FOREIGN FISHES

AQUATIC PLANTS, SNAILS AND SUPPLIES

STOCK AQUARIA

Galvanized Metal Frame, Enameled and Gold-Striped, Bottom Slate or Ribbed Glass.

	Plain.	On legs
No. 1. 11"x7"x7"	\$1.25	\$1.50
" 2. 14"x9"x9"	1.50	2.00
" 3. 17"x11"x11"	2.25	2.75
" 4. 20"x13"x13"	3.00	3.75
" 5. 24"x12"x14"	4.75	5.50

20% additional for oxidizing.

Solid Brass Frame, on Projecting Slate Bottom or on Legs.

No. 1. 12"x 6"x 8" high, 2½ gal.	\$2.50
" 2. 14"x 8"x10" " 5 "	3.25
" 3. 16"x10"x12" " 9 "	4.75
" 4. 18"x12"x14" " 14 "	5.75

20% additional for nickel-plating or oxidizing.

Steel Angle Frame, Heavy Plate Glass, Slate Bottom, Flush or Projecting.

No. 3½. 24"x14"x14", 22 gal..	\$8.00
" 4½. 30"x16"x16", 36 " ..	12.50
" 5½. 36"x18"x18", 54 " ..	20.00
" 6½. 42"x20"x20", 80 " ..	35.00
" 7½. 48"x22"x22", 110 " ..	60.00
" 8½. 54"x24"x24", 145 " ..	95.00
" 9½. 60"x26"x26", 180 " ..	135.00

All our aquaria are so constructed that water cannot come into contact with the metal.

All sizes and shapes made to order. We charge only actual cost for packing and cases.

FISH FOODS

	Per Tin box.	Per lb.
Natural Fish Food.	\$.10	\$.50
Universal Fish Food.15	2.00
Ground Dried Shrimp.10	1.00

	Per Tin box.	Per lb.
Ground Dried Flies and Insects20	3.00
Ground Dried Daphnia. \$.20		\$3.00
Infusoria Creating Food .15		2.00

Correspondence Solicited. JOSEPH TAUBLES, Manager. No Catalogues

IF YOU

Are Looking for Something Extra Fine in Broad-tail Telescopes

Don't Forget W. H. HEIMBACH

Breeder and Importer of FINE FISH

Snails Plants

FISH FOR SALE AT ALL TIMES!

413 NORTH TENTH STREET
ALLENTOWN, PA.

MECCO GARAGES

Here is a chance to make money

Write for Proposition Give References

— ADDRESS —

M. E. Corrugating Co.
COVINGTON, KENTUCKY





Notes on the Genera *Notropis* and *Fundulus*

DR. R. W. SHUFELDT

In commenting on the genus *Notropis* in their "Fishes of North America," Jordan and Evermann tell us that "As here understood, *Notropis* contains about 100 species of small Cyprinoids, all of them confined to the streams of North America east of the Rocky Mountains. They are in some respects a degenerate type—probably of comparatively recent origin and perhaps descended from such forms as the European *Alburnus* and *Luciscus*. They are feeble fishes of small size, none of them of value as food for man, but of great importance as food for the larger predatory fishes, particularly the *Centrarchidae*. The species are highly variable, readily affected by surrounding conditions, while the really distinctive characters are few. The identification of species is very difficult, and in the case of young specimens often impossible" (Part I, p. 255).

Even the excellent Key to the many species of *Notropis* given by these authors must be used with caution, as the individual variations are sometimes so great. There is a large literature upon them, as any one will appreciate who undertakes to study our "Shiners," the common name given to the species of the genus *Notropis*. There may be as many as 125 or 130 species and sub-species of the genus *Notropis* in our fish fauna, but personally I have examined very few of them.

Last summer I obtained from the Potomac River, near Washington, about thirty living specimens of a sub-species of *Notropis*, which seemed to agree with *N. hudsonius amarus* of Girard (Proc.

Ac. Nat. Sci. Phila., 1866, Potomac River at Washington); but I am not quite positive of this, and for reasons given further on. I succeeded in making a photograph from life of an average-sized specimen, and a reproduction of my photograph is here given in Figure 1. *Notropis hudsonius* is a species known in the vernacular as the "Spawn-eater," the "Spot-tailed Minnow," and the "Shiner." Doubtless these names are also applied to *N. h. amarus*. Washington fishermen use large numbers of them during the black bass season, fishing in the Potomac.

This sub-species doubtless intergrades with typical specimens of *N. hudsonius*; while the latter always exhibits a black caudal spot, and this may be altogether absent in *N. h. amarus*. Doctor Abbott contended that the last-named fish was a distinct species; and I am inclined to believe it is—the intergrading notwithstanding.

They are extremely active and nervous little fishes, and upon these accounts they are very difficult to photograph when living and in the best possible condition. I am sure it has not been done very often. Indeed, I have not seen a photograph of this fish published heretofore anywhere. It will be observed that the "caudal spot" in my photograph is entirely absent. This group stands in need of much further study and investigation.

My attempts to keep this species of shiner in a small aquarium failed, although I took considerable pains with them; they became too nervous and excited to eat any sort of food, and soon



Fig. 1 Shiner (*Notropis hudsonius amarus*) Male: Natural Size



Fig. 2 Common Killifish (*Fundulus diaphanus*) Natural Size

Photographs from Life by the Author

die. This does not apply to the "Killifishes," however—that is, the fresh-water species; for any of these soon adapt themselves to aquarium life and conditions. This constitutes another very large genus of wide distribution—the genus *Fundulus*.

Jordan and Evermann have said of them in their "Fishes of North America": "Species very numerous, mostly American,* inhabiting fresh waters and arms of the sea. They are the largest in size of the Cyprinodonts, and some of them are very brightly colored. They are oviparous and feed chiefly on animals. Some of them are bottom fishes, burying themselves in the mud of estuaries; others swim freely in river channels and bays; still others are "top minnows," surface swimmers, feeding on floating insects in swamps and streams" (p. 633). These authors united *Fundulus* with the genus *Zygonectes*; and while the extremes of the two genera are very different in form and general appearance, they are certainly closely allied, as they approach each other in common characters.

Personally, I have taken a number of different species of these cyprinodonts at various times in my life; and at this writing I have two specimens of *Fundulus diaphanus* living in one of my aquariums. They were taken by me in a small branch of the Potomac River, near Washington, where the species is very abundant. This species I have successfully photographed a number of times, and one of my best results is here reproduced in Figure 2. It is a male of *F. diaphanus*, or Banded minnow, or Killifish. A subspecies of this form has

been described—*F. d. menona*—from the fact that it was first taken in Lake Menona, near Madison, Wisconsin. Its range is from Ohio westward to the Mississippi River, and to a limited extent perhaps a few hundred miles south of Chicago.

The coloration and markings of some of the species of these Killifishes are very beautiful, and none is more so than the males of the Common Killifish, *F. heteroclitus*, which, when I was a boy, was very abundant in the salt-water ditches in the marshes at the foot of South Street, in Stamford, Connecticut. They also swarmed in the bay at certain states of the tide. Two or three subspecies of *F. heteroclitus* have been described.

The Puffer Fish

It is true that there are no mermaids in the sea, but the species of life that do exist there are in many ways equally as interesting as the mythological folk. Take the little puffer fish, for example, which has attracted the attention of scientists from earliest times on account of its shrewd habit of defending itself by inflation. The moment it scents danger in the form of a larger fish searching for a dinner, it instantly distends itself with water until it becomes almost spherical in shape, so that no ordinary fish could swallow it. Director C. H. Townsend, of the New York Aquarium, placed a few good-sized scup, or porgies, in a tank which contained a dozen young puffers, about two inches in length, which the hungry scup attacked at once. Instantly the baby puffers inflated themselves and became almost globular in form, so that the larger fish were unable to do more than knock them about like toy balloons, too large to be swallowed, and on which they could get no hold, no matter how hard they tried.—*Popular Science Monthly*.

*The few European species referred to *Fundulus* seemed allied to the sub-genus *Xenisma*. The Asiatic and African forms are allied to or belong to the group *Zygonectes*. In some of them the anal fin is much larger than in the American species.

The Respiration of Fishes

REV. J. G. WOOD

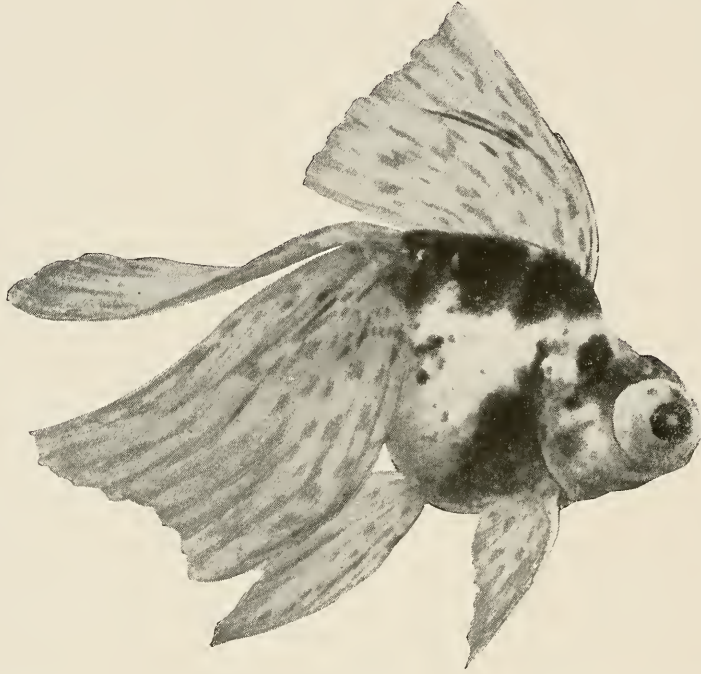

Queen Lil

Owned by Franklin Barrett

Photo by Geo. H. Seip

In the higher beings, the oxygen which is contained in the atmosphere is brought in contact with the blood in a very beautiful manner, and in the act of breathing a very difficult problem is solved.

How is it possible to allow the atmosphere to come in contact with the blood without permitting it to escape from the vessels through which it flows?

This difficulty is surmounted in a very simple manner. A portion of the circulating apparatus is so contrived that the vessels are diminished to the minutest possible size; so small, indeed, that there is only just room for the globules of the

blood to pass singly. The walls of the vessels are extremely thin and delicate, and are made of a substance which allows the passage of air while it retains the blood. In the larger vessels, such a structure would be impossible, on account of the pressure to which the walls are subjected by the volume of blood that rushes through them; but in those parts which are exposed to the air, the currents are so minute that they exercise comparatively little force, and are easily contained within their delicate walls.

It is, of course, an important point that a very large surface should be ex-

posed to the air, and it is hardly possible to find a better example than the gills of a fish. At first sight they look like a series of comb-like organs, scarlet with the blood that is seen through their delicate coverings; but if they are closely examined, they will be found to possess a most beautiful form, exposing a very large surface, and at the same time occupying a very little space. Each tooth of the comb is composed of innumerable plates of membrane, traversed by the blood vessels, and admitting the air on both sides. In fact the gills remind the observer of the leaves of a slightly closed book, in which a very large amount of surface is compressed into a very little space.

I have been particular in describing these gills because they demonstrate the real action of respiration better than any structure that can be found. Moreover, they can easily be obtained, and an ordinary magnifying glass is sufficient to exhibit their wonderful mechanism.

The manner in which a fish breathes is simple enough. It opens its mouth and admits a certain quantity of water, just as we admit air into our lungs. It then closes its mouth and drives the water out at the gill-covers, causing it to wash over the gills in its passage. The oxygen contained in the water thus comes in contact with the blood, and so the fish manages to breathe.

When the fishes in the aquarium remain persistently at the surface, "sucking air" in common parlance, it is an indication of a lack of oxygen in the water, which may be due to pollution or overstocking—more fishes than the plant life of the tank can support. When a tank approaches this condition, we are told by aquarists more enthusiastic than accurate, that the fishes are taking the air and passing it over the gill capillaries, and

that in the procedure the delicate organs are "burned" by the raw air. On the contrary, the fishes are merely gurgling the air and water in the mouth, thus charging the water with oxygen; the air is regurgitated (passed out through the mouth), while the charged water passes back over the gills in the normal way. In other words, the fish is endeavoring to oxygenate the water in the same fashion as when the aquarist dips a cupful from a tank and pours it back for the same purpose.

Overstocking is a fault almost confined to the beginner. The experienced aquarist realizes that the welfare of his fishes is as dependent upon ample water-volume per fish as it is upon the proper foods. Rather than try to keep as many fish as possible in a given tank, he endeavors to give each fish as much water as his equipment permits. An aquarium should never be so thickly populated that a rise of temperature will cause discomfort due to the rapid diffusion of oxygen into the atmosphere. Water will hold more oxygen when cool than when warm. A rise of temperature of 16 degrees in a tank will result in a loss of half of the oxygen it was able to retain at the lower point. Thus the capacity of an aquarium should be based upon the highest temperature to which it is apt to be subjected, and rapid fluctuations may be expected if the vessel be small. Safety first among aquarists means too few rather than too many fishes.

The American Federation of Goldfish Fanciers has merged with the Brooklyn Aquarium Society, the members having been elected to the latter organization in a body.

He that would catch fish, must venture his bait.

On *Anolis Carolinensis*

ERNEST LEITHOLF

Late in the summer of 1916 I secured three specimens of the so-called chameleon, *Anolis carolinensis*. These found a home in a moss-bottomed terrarium, in which some shrubs had taken root. A miniature pool was arranged to supply the needed moisture and *Anolis* seemed contented.

A short time later, while making an examination of the case, my son discovered an egg. Having not the slightest idea as to how it might be regarded by the adults, and particularly while in confinement, we removed it to a small jar, placing it on top of some moss. Time passed and we about gave up hope of having it hatch. Finally, seven weeks later, while removing the cover to show the egg to Dr. Cruickshank, president of the Pittsburgh Aquarium Society, out of the jar leaped a lively little chameleon about an inch and a half long. To recapture it as it scampered about the conservatory was quite a task. We were considerably elated, because, but a few days before, we had read that an egg had hatched in the London Zoological Garden, which was considered to be the first time the species had been propagated in confinement.

Then followed several weeks during which the baby was kept isolated, as we feared it might be attacked if placed in the terrarium with the old ones. However, one day it was permitted to join them. It entered timid and scared, the old ones looking upon it with apparent indifference. After a few days the mother became interested, and was observed to take a position near the baby, as if to defend and protect it. One evening my son, greatly excited, called me to the terrarium. There was baby atop a small evergreen, the mother caressing and licking its body, while its tail wagged

and twisted in seeming appreciation! It was truly a delightful "family reunion."

I have been unable to secure any information relative to the breeding habits of the species, but my observations lead me to believe that the mother at least evinces some interest in the welfare of her offspring.

(*Anolis carolinensis* is a not uncommon lizard in Louisiana, and probably elsewhere in the Gulf States. I have seen great numbers in the old cemeteries of New Orleans. It is quite docile and tame, and will soon take flies from the fingers. During the warmer months of the year it is often sold in northern pet shops, and is the unfortunate species that a few years back was sold by fakers on the streets, a ring about its neck, attached to a chain and pin, and designed to ornament milady's person. As applied to this species the name chameleon is a misnomer, as it bears no direct relationship to the true chameleons. Incidentally, the color changes have no connection with the color of the object on which the individual may be resting. Vivid green ones may be seen on a brown fence rail, or on a white marble tombstone, as I have personally observed. A writer, whose name I do not now recall, considers temperature to be the controlling factor, the green phase being induced by low and brown by a high temperature. Be this as it may, the green stage has been observed on the warmest days, when the thermometer registered beyond the hundred mark.—*Editor.*)

The Optimistic Thought

Though futile now seems the wishing, though hard the chill wind blows, soon once more we'll all be fishing out where the wild weed grows.

Blame-all and praise-all are two blockheads.

BREEDING A CORYDORAS

FRANK DUNGAN



Corydoras paleatus

Brazilian Catfish or Panzerwel

When I first saw a Brazilian catfish, the panzerwel, as our German friends call it, I was rather fascinated, and this regardless of its somewhat somber color scheme of browns. Interest in a species, especially among aquarists, usually promotes a desire to breed it, more so if its habits be little known, and in this respect I am not an exception. My friends could tell me little of the panzerwel, other than that it was an inoffensive and rather shy little fellow, and that it might be kept with goldfish. I was obliged, therefore, to proceed along lines that in my estimation were favorable to the desired end—propagation.

Specimens gradually were added at intervals to my collection, and I now have three males and two females. The species seems to be *corydoras paleatus*, and agrees with the first illustration, with the addition of several dark blotches on the sides. These markings are shown in the second illustration. My fish combine the markings of the two forms. The coloration can be briefly described as yellow-

ish-brown, with dark or blackish markings, the fins speckled or spotted. The sexes may be distinguished by the relative shapes of the fore-dorsal. The first ray of that of the female is noticeably shorter than the next, whereas, in the male the first ray is nearly as long as the next. The males are more slender than the females.

The panzerwel is a bottom fish, prowling timidly on the sand among the plants, and seldom rising. The tank in which mine find a congenial home contains a considerable accumulation of humus or sediment, the value of which will become evident later, and is sparsely planted with *Sagittaria*. It is in a rather sunny part of my conservatory, which promotes the development of algæ upon the glass and plants—to the detriment of the latter.

Spawning occurred on November 8th, the day following the Presidential election, at 5 A. M., and continued for about three hours. The pair proceeded like goldfish, but the male "drove" the female much more rapidly, the spawn being

scattered about promiscuously in a like manner. The eggs were pearly white, remarkably adhesive, and stuck tenaciously to the glass; none seemed to become attached to the plants. I counted 112 on the front glass alone. The aquarium was maintained at an average temperature of 70 degrees Fahrenheit, and in five days the eggs hatched; the fry dropped to the bottom and were lost to view in the feathery humus. Where

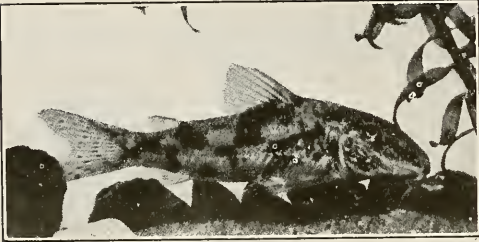

Corydoras species

each egg was attached to the glass a tiny white circle remained, and now, after two months, some may still be seen.

The value of the deposit of sediment upon the bottom of the tank will now become evident, because, after the yolk-sac was absorbed, the youngsters found amongst it the much-needed infusoria. At this time they may be said to resemble tadpoles. I made no microscopical examinations, but as soon as they were large enough to be easily seen, they resembled closely the parents in shape and markings. Other than the minute animal and vegetable life naturally present in the aquarium, I have fed nothing but daphne and the cyclops that were collected with it. I have not been able to observe them eat the live water-fleas, and it may be that the dead ones falling to the bottom are more acceptable. In any event they spend most of the time wiggling and wriggling about, sometimes standing on their heads with tails aloft, rooting vigorously in the humus. At intervals one may wriggle up the side of

the tank and nibble algae, but mostly they are upon the bottom.

The youngsters seem to be quite adaptable to changes in temperature, as at time the thermometer in their tank has registered as low as 58 degrees, yet they seemed as lively as when much warmer.

I do not know just how many eggs were expelled, but surely more than the 112 counted. After the spawning the parents remained in the tank for two days, and during this time they possibly ate such as had fallen to the bottom, but they did not molest those attached to the glass. The heaviest mortality occurred during the third and fourth weeks. How many are still alive is problematical; possibly twenty-five, or even fifty.

Notes on the Panzerwels

It is now more than a year since Mr. Dungan expressed to the editor his interest in the Brazilian catfishes and a desire to breed the particular species he then had in his collection. While *Corydoras paleatus* has been bred in Europe, Mr. Dungan is the first American aquarist who has met with success; if there are others who have bred it, and they have not published the fact, let them now hold their peace. Mr. Dungan is to be congratulated. Those who assert that American aquarists accomplish little original research will do well to recall that George W. Price first dispelled all doubts as to the breeding habits of the Black-banded Sunfish, *Mesogonisteus chaetodon*; William L. Paullin bred and reared *Pterophyllum scalare* (the surviving young are now as large as the parents); Leitholf's study of *Anolis carolinensis*; and most recently, Dungan and the Brazilian catfish.

Quite a number of fishes of the family SILURIDAE (catfishes), natives of North and South America, Asia and

Africa, are known to aquarists. Those from South America have probably attracted the most attention because thus far they have been most readily obtained. The breeding habits vary with the species; relationship in fishes does not necessarily indicate a similarity in the methods employed to protect eggs and young. With one exception the labyrinth fishes build foamy nests of bubbles at the surface, in which the eggs incubate; *Betta pugnax* is a mouth-breeder after the manner of *Haplochromis stringigena*. This latter species belongs to the family CICHLIDAE, the members of which usually deposit the eggs on a rock or other object to which they adhere while developing.

The European papers describe the habits of *Corydoras paleatus* substantially as does Mr. Dungan, but state that the eggs adhere to the plants, giving the number as about one hundred. When the editor saw Mr. Dungan's youngsters, about six weeks after hatching, the rings he describes as remaining on the glass after eggs hatch still persisted. *Corydoras paleatus* was formerly called *Callychthys punctatus* and *C. fasciatus*. *C. macropterus* and *C. undulatus* have similar habits. *Callychthys callychthys*, a nomenclatorial curiosity inasmuch as the systematists have not contrived a valid excuse to place it in another genus, still bearing the name given by Linneaus many years ago, is said to build a foamy nest in which the eggs and young are accorded care by the male.

Some years ago a paper on the "Spawning and Development of Panzerwels," species not stated, by Wittig Brannschneig, appeared in a German periodical, and from which the following excerpts (translation by Ellen K. Innes) are taken:

"Towards midnight I noticed a furious driving. Both the males touched the

female with their mouths, whereat she made a chewing or sucking motion. This tasting or licking, as I would like to call it, always took place on the back in front of the dorsal fins, and on the head, rarely on the sides. During the whole of the spawning the males were of a bright yellowish color. The fins were dotted. The mottling had entirely disappeared. Immediately the female begin to spit. With a quick motion she seized the male on the side and fastened herself with strong sucking onto the male in the neighborhood of the ventral fins near the anus, where there is the opening for the flow of the sperm. With a trembling movement they remained for a while—ten to twenty seconds—the male lying somewhat on the side, turning the belly towards the female. During the foregoing three to four eggs have fallen into a pocket, which the female has formed by laying together the ventral fin. * * *

After this act followed a short condition of weakness, especially for the female, who, during a renewed teasing by the male, remained quiet. After she had revived, she swam around among the plants searching for a special leaf of *Ludwigia*, which she touched on the under side with a spitting motion of the mouth, whereby a pasty substance was exuded and fastened to the leaf. Then, with an agility that so plump a land animal would not have trusted herself to she turned on her back and quickly pressed the eggs on the leaf, where she stuck them so tightly that I have never noticed any fall to the ground. * * *

"When fertilization takes place I could not definitely say. Either it takes place in the pocket (formed by the ventral fin) or when the eggs are fastened on the leaves. The latter is more probable. The opinion that the sperm is admitted into the fin-pocket is, on account of the position of the fish, completely barred

out. On the other hand, it is possible that through the sucking operation of the female the thread of sperm was drawn through the gills and thrown back on the ventral fins and here the eggs were fertilized. Against this speaks the fact of the tightly-closed edges of the fin-pocket. There is little probability that the sucking alone is a stimulation for the ejection of the sperm, for at that time the eggs are farthest away from the sexual organ and placed where they would have the least chance of being fertilized. So the theory only remains that the female sucks out the sperm and spits it against the leaf, where the eggs are fastened, and here fertilization takes place. * * *

"By 2.45 A. M. the spawning was over. The female looked around for food, and at the same time the mottling appeared beautifully dark. The male, on the contrary, retained his fawn coloring for a longer time. * * *

"As already mentioned, the eggs were fastened to the leaves by means of a pasty substance. So tightly were they fastened there that if any part of an egg was torn off, the upper part of the leaf came away with it. The eggs are exactly 2 mm. (two twenty-fifths of an inch) in diameter, and somewhat opaque. In the first days there is little change in the eggs to be noticed. In about three days one sees distinctly, deep inside of the egg, the fish embryo in the form of a ring lying around the light spot, and if one observes more carefully, the proportionately large heart beating at intervals of a few seconds. The picture is much clearer in about five days, when the fish has a well-developed tail. This tail is three times as long as the egg and projects out from the egg skin. In the egg one now sees a longish body with the yolk-sack. The eyes are also formed and appear like dark spots. Soon the

circulation of the blood begins and as the tail is glass-clear, this is a most interesting study of which one never tires. During this interval the egg sheath cracks more and more, and through a clapping motion the fish can free itself. Superficially observed, the animal at this time resembles a tadpole. By and by the fins begin to appear and the fish more and more resembles the old ones. * * *"

(Mr. Brannschneig's observations of the development of the embryo were, of course, made through a compound microscope.—*Ed.*)

A Tank Heated by Electricity

In these progressive times it is unusual to find a whole community opposed to electric light. It is more unusual to find such a community within the well-cultivated province of The New York Edison Company. Sad and true as it undoubtedly is, the fact continues at 124 East Nineteenth street, under the very eaves of the electrical sanctuary. The reactionaries in question are of Japanese origin and so little acclimated as to demand an element identical to a degree with that of their equable and more temperate Nippon. Hereupon rests their mention in these modern and enlightened pages.

Some time since, when the artist, Robert W. Chanler, took up the principles of Japanese design, the question of models and idea-promoters at once presented itself. Leaf and bird forms, alive and flourishing, were soon imported and housed in a cozy garden at the rear of the hallway. There were still wanting the sinuous fish forms that glide in and out of most well-regulated Nipponese conceptions.

Accordingly nymphs, fantails, and gorgeous "telescopes" were introduced to disport at will among plants, snails,

and polywogs in a very special tank as big as a packing case. Then came cold weather, with cold water, and a melancholy company of goldfish found themselves far from home with the mercury falling.

It was then that Mr. Chanler sought out the good offices of the Edison man. This ingenious functionary, though on better terms with calories than with fan-tails, bethought himself of combining the

itself ungratefully conservative. Not only do these electrically preserved fish huddle in corners when the lights are on, but at intervals they come gasping to the surface as if unconscious of the fact that electricity uses up less oxygen than light in any other form.

Happily, the parrots, the pheasants, the yellow Amazon bolbas, the finches, with their companions of many names and voices and colors, are more ad-

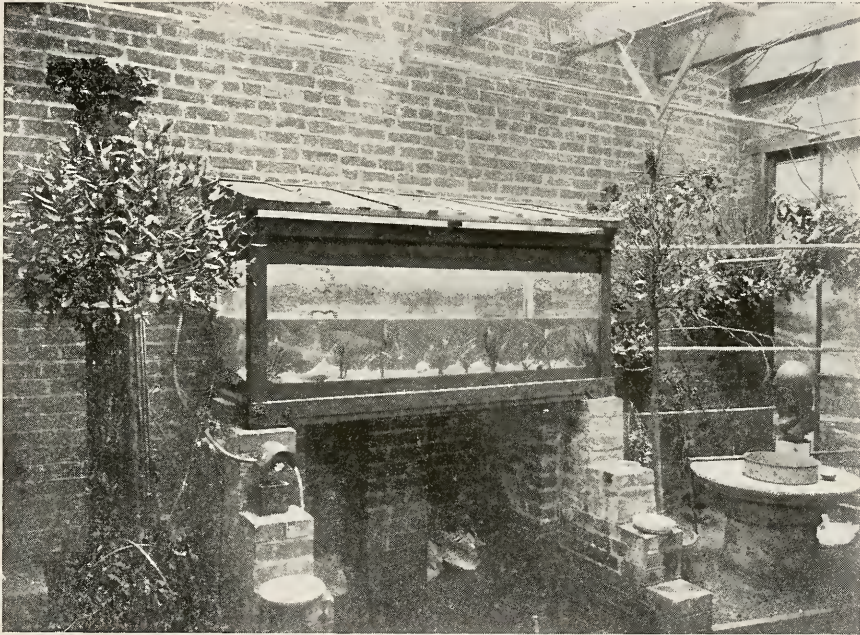

Mr. Chanler's Electrically Heated Aquarium

two, with the result that an ordinary Simplex water heater was attached to the pipe immediately beneath the tank. Whatever the winter-bound inmates thought does not matter. What they did in recognition of this abrupt return of vernal conditions is still the delight of the Japanese in attendance.

However, at the time of the innovation, current was further solicited in the form of light bulbs inserted under the cover. It is in this connection that the privileged community below has shown

vanced. Indeed, they seem never more themselves than when of an evening or a dull afternoon the garden is alight from a host of lamps shining through the roof and the green glass making up the side walls. At this the fish proceed to hide themselves among the shaded plants at the back of the tank. But then too much ought not to be expected.—Reprinted by permission, with courtesy of use of illustration, from *The Edison Monthly*.

Aquatic Life

A monthly magazine devoted to the study, care and breeding of native, tropical, gold and fancy fishes, other animals and plants in the household aquarium.

W. A. POYSER Editor
JOSEPH E. BAUSMAN Publisher
542 E. Girard Avenue, Philadelphia

Entered as second-class matter, September 2, 1915, at the Post Office, Philadelphia, Pa., under Act of March 3, 1879.

Yearly Subscription \$1.00
Foreign Subscriptions 1.35
Single Copy 10 cents

Payments may be made by express money order, draft, post office order or registered letter. Foreign remittances should be by international money order.

Advertising rates made known on application. "Aquatic Life" is the only magazine in America devoted exclusively to aquatic life, and its value as an advertising medium in this field of nature study is unequaled.

Copyright 1917 by Joseph E. Bausman

Vol. II February, 1917 No. 6

The Iron-colored Minnow

Back in 1866 Professor Cope described a minnow from the Schuylkill River, calling it *Hybopsis chalybaeus*. Later we find it referred to as *Luxilus chalybaeus*, and nowadays the books tell us that the name is *Notropis chalybaeus*. So be it. We will accept the position accorded it by the ichthyologists, inasmuch as in the classification of animals the position of a species is based upon its relationship as indicated by anatomical details; aquarists are more interested in the habits of a species.

The iron-colored or steel-colored minnow is an attractive little fellow in both coloration and actions. It inhabits the lowland streams and swamps from Pennsylvania to Georgia, and will usually be found in schools. The members of a school have the peculiar habit of heading in the same direction, and while a passing fish of an alien species, an enemy

perhaps, will cause them to "break rank" they soon return to the characteristic formation. Even in an aquarium the habit is noticeable though they be perplexed by the presence of other fishes, and that they are gregarious will be noticed when a dozen or so are kept in a tank with other species, as they herd together and keep aloof. This minnow is dark above; pale yellow below; a broad, lustrous black band running from the snout to the base of the tail; fins plain. During the breeding season, springtime, the abdomen of the male becomes bright orange.

Nothing seems to be known definitely regarding the breeding habits. Mr. L. M. Dorsey, of Philadelphia, in whose aquarium we recently saw the species, and in which it was apparently thriving in company with goldfish and black-banded sunfish, will make an effort to propagate it. _____

At the last annual exhibition of The Aquarium Society, New York, Mr. Otto Gneiding was awarded six first, five second and four third-prize ribbons on goldfish breeds, his entry including ribbon-tails, broadtails and young lionheads. _____

The Aquarium Society, New York City, is arranging to appropriately celebrate its twenty-fifth anniversary during the month of April. _____

When I lived in Chicago I had quite a number of fishes and experimented with many kinds of foods. I found that live crayfish, cut into small pieces, was greatly relished by all the fishes, some of which would never touch beef. I kept two Rainbow Darters or Soldier-fish (*Etheostoma coeruleum*) for almost a year on this food, and this species is very difficult to keep in an aquarium for any considerable length of time.—G. P. von Harleman.

The Unity Hatchery

The average city breeder of goldfish or the tropical species aptly terms his establishment a "hatchery," inasmuch as there seems to be no diminutive of the name. These little laboratories of aquatic biology, measureable in square feet, form quite a contrast to the vast commercial hatcheries specializing in food and game fishes. A view is shown of a pond of the Unity Hatchery, New York. This

people the ponds. From them came the pickerel shown in the New York Aquarium. Of smaller kinds, those we may call "aquarium fishes," may be noted *Fundulus diaphanus* (killifish), *Rhinichthys atronasus* (black-nosed dace), *R. cataractae* (long-nosed dace), *Notropia cornutus* (shiner), *Abramis crysoleucas* (roach), and *Exoglossum maxillingua*. These little fishes are used primarily as food for game fishes placed in waters



A Vista—Unity Hatchery

enterprise covers a water area of nearly two hundred acres, and has a production quite in proportion to this great expanse. Last spring between sixty and seventy million yellow perch and two hundred and fifty to three hundred thousand small-mouth black bass were hatched. More than thirteen million fishes and eggs have been shipped away during a single month.

Bass and perch are not by any means the only fishes of Unity waters; more than twenty-two species are known to

lack such forage. At Unity sunfishes and eels are *persona non grata*, it being the opinion that they enter into hard competition with the more valuable fishes and destroy more than they are worth.

Mr. Ernest Clive Brown, manager of the Unity Hatchery, is not only interested in food and game fishes, but in "aquarium fishes," too. Incidentally he is an enthusiastic admirer of AQUATIC LIFE, and declares that it should be brought to the attention of all persons interested in aquaria.

Philadelphia Goldfish Fanciers

The regular meeting of the Philadelphia Goldfish Fanciers' Society was held in Saull's Hall, 802 West Girard avenue, Wednesday evening, January 17th.

The regular competition for the meeting was among single-tailed goldfishes.

AWARDS: *Scaled Single-tailed Telescopes*; blue ribbon, Gustav Armbruster; red ribbon, Joseph E. Tyler; yellow ribbon, Charles Hinkle. *Scaleless Single-tailed Telescopes*; blue, Mrs. Elizabeth Ahlers; red, Francis X. Garcia; yellow, Charles Hinkle. *Scaled Nymphs*, blue ribbon, William J. Christy. *Scaleless Nymphs*, blue, Mrs. Elizabeth Ahlers; red, Charles Hinkle; yellow, William J. Christy.

A special competition was held for the silver cup presented by Mr. Charles E. Visel for the best calico broadtail telescope—the winning fish was entered and bred by Joseph E. Bausman.

The judges in both competitions were Messrs. Thomas Ayling, R. L. Harding and James Fleming.

New members elected: Messrs. Sidney Skillman, Charles H. English, Charles C. Hampel, Robert F. Sheppard and William J. Miles, Jr.

The proposed amendment to the by-laws changing the method of judging fish from the point system to that of comparison was defeated.

The next regular meeting will be held on Wednesday evening, February 21st. The competition will be for ribbon-tailed telescopes and Japs. Three ribbons will be awarded in each class.—*Fred Richardson, Secretary.*

The first public exhibition of the Boston Aquarium Society was held in the Mechanics' Building, January 9th to 13th inclusive, in conjunction with the Boston Poultry and Pet Stock Show. The goldfish predominated in the thirty tanks of various sizes, and some very good fringetail and veiltail black and calico telescopes and other breeds were shown by F. S. Blodgett, Dr. A. B. Coffin,

W. M. Copeland, F. G. Jones, William Leeds, H. L. F. Naber and F. A. Packard. Tropical fishes were shown by Walter H. Chute on an electrically illuminated table.

The exhibition was crowded on all days, and the members kept busy explaining the principles of the self-sustaining aquarium and the points of interest of the various fishes. As a result of the exhibition the society enrolled fifteen new members, making a total of forty-four to date.

Inasmuch as the show conflicted with the January meeting of the society, the meeting was held on the 19th, one week later than usual. The use of the main hall of the Museum of Natural History has been secured for future meetings, which will be held on the second Friday of each month.—*Walter H. Chute, Secretary.*

A dip-tub for the removal of humus or sediment from the bottom of the aquarium is an essential tool to the fish fancier. It may consist of a straight glass

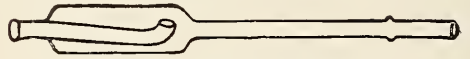

COMPOUND DIP-TUBE

Courtesy Aquarium Stock Co.

tube or be a compound "mud-lever," such as is illustrated. Both are used in the same manner. Held between the thumb and second finger, the index finger over the upper end, the lower opening is placed close to the bottom of the aquarium over the matter to be removed, then by removing the index finger the sediment is carried into the reservoir by the upward rush of the water. The reservoir is emptied by inverting the tube into a convenient receptacle, and the procedure repeated until all the humus has been removed.

The dip-tube, floating thermometer and handling net are absolutely essential accessories for the care of the aquarium.

If you don't know the value of money, go and borrow some.

Books for Aquarists



The Home Aquarium and How to Care for It. A guide to its fishes, other animals and plants. By Eugene Smith. 213 pages, 137 illustrations, cloth binding, \$1.20. Add parcel postage on two pounds.



Goldfish and Its Culture. Practical instructions for pond breeding, shipping, care of the aquarium, and the general subject. By Hugo Mullertt. 155 pages, 15 illustrations, cloth binding. \$2.00. Add parcel postage on two pounds.



Fish Culture in Ponds and Inland Waters. The most recent book, covering the propagation of goldfish, food and game fishes, and aquarium management. By William E. Meehan, Director of the Fairmount Park Public Aquarium, Philadelphia, and former Pennsylvania State Fish Commissioner. 287 pages, 22 illustrations, cloth binding. \$1.00. Add parcel postage on one pound.



Japanese Goldfish. A guide to the Japanese methods of culture. By Dr. Hugh M. Smith, U. S. Commissioner of Fisheries. 10 full-page colored plates, numerous text cuts, 112 pages, cloth binding. \$2.00. Add parcel postage on two pounds.



Life of Inland Waters. Needham and Lloyd. A big book containing 438 pages and 244 splendid illustrations. It presents a survey of the whole realm of freshwater aquatic life. The only American publication on the subject, and one that will materially assist the aquarist in solving the many problems encountered. \$3.00. Add parcel postage on three pounds.



The Freshwater Aquarium and Its Inhabitants. A practical work for the aquarist. By Egging and Ehrenberg. Freely illustrated, 352 pages, art cloth binding. \$2.00. Add parcel postage on two pounds.



Address **AQUATIC LIFE**

Book Department

542 East Girard Avenue, Philadelphia

The Nature Study Review

OFFICIAL JOURNAL
AMERICAN NATURE-STUDY
SOCIETY

The numbers for the coming school year will be filled with special articles from practical teachers dealing with actual works, methods and suggestions for school gardening, elementary agriculture and nature-study.

DO NOT MISS ANY OF THEM

\$1.00 per year.

15c per copy.

SUBSCRIBE NOW

Add for Canadian Postage, 10c. Foreign Postage, 20c. With Aquatic Life One Year, \$1.50.

Address All Orders to

The Nature Study Review

ITHACA, N. Y.

New & Direct Importation of Tropical Fish

From South America

MANY SPECIES QUITE NEW

Address

GENERAL SCIENTIFIC COMPANY

Corner 10th Avenue and 206th Street

New York City

N. B. GOLDFISH FANCIERS!
LOOK! Get your names on our list
for very special announcement.

AQUARIUM STOCK CO.

150 Chambers Street :: New York City

Aquarium Specialists

GOLDFISH, FOODS, PLANTS, SNAILS, ETC.

Combination Natural Fish Food - Sample Can 10c

Imported Shrimp Fish Food - - Sample Can 15c

Imported Wafer Fish Food Large Sample Box 10c

Special Prices on Quantity Lots Cash With Order

Catalogue Sent Upon Request

ORDERS AMOUNTING \$2 DELIVERED POSTPAID

Mail Orders Promptly Attended To

EDWARD S. SCHMID

Emporium of Pets

ALL KINDS OF GOLDFISHES AND AQUATIC PLANTS AND WATER LILIES

712 Twelfth Street, N. W., Washington, D. C.

Taxidermy

Send for Catalog

Aquatic Life :: :: :: Volume One

"Aquatic Life" is conceded the best illustrated aquarists' magazine in the world. The volume costs two dollars, postage prepaid.

Address, AQUATIC LIFE, 542 E. Girard Avenue, Philadelphia

Thomas Ayling

FINE BROAD-TAIL TELESCOPES

Some Nice Young and Breeders at Reasonable Prices

845 East Ontario Street :: Philadelphia

DRIED SHRIMP - (Ground 75c per Pound)

Postpaid

Special Price on Quantity Lots

My Natural Fish Food Sample can 15c Per Pound \$1.00

CANADIAN BIRD STORE

2139 W. Van Buren Street

Chicago, Ill.

ONCE YOU TRY, YOU ALWAYS BUY

Gnadt's Perfect Fish Food, 10c box

Pulverized or Whole Shrimp, 75c. lb.

BREEDER OF FANCY GOLD AND TROPICAL FISHES

Manufacturer of all kinds of aquariums

Fish nets made of finest netting, 15c.

Great reduction by dozen or gross.

BROADWAY BIRD STORE

P. F. GNADT, Proprietor

1632 Broadway

Greenhouse, 1630 Broadway

BROOKLYN, N. Y.

Red Missouri Granite Chips. The aquarium ornament de luxe and artistic. 25c. per lb. Add postage to your zone.

Japanese Dojos. Scavengers for your aquarium. The weather fish. Eats like a cow; looks like a walrus. Will not harm goldfish. Safe arrival guaranteed. Small, 50c. each; large, 75c. Add 10c. for shipping can.

S. CHICHESTER LLOYD

SUITE, 407 HOLLAND BUILDING, ST. LOUIS, MO.

THE AQUARIUM WORLD

Is a Section of "THE PET STOCK WORLD"

It's Slogan "FOR MORE PUBLICITY TO THE AQUARIUM WORLD'S INHABITANTS"

Trial, 3 Months 10c 6 Months 25c Yearly 50c

Pet Stock World, 652 N. Chester, Baltimore, Md

To Prevent Many Fish Diseases
USE REGENIA AQUARIUM SALTS

To replace natural salts in waters as absorbed by fish and snails

6 POWDERS IN BOX, 25 CENTS

Regenia Chemical Co., Sta. K, Philadelphia

Negotiations Pending

for a binder that will hold twenty-four numbers of Aquatic Life. Description and price will be given in advance of publication if requested.

AQUATIC LIFE

542 E. Girard Avenue, Philadelphia

STARVATION vs. POISON



Keeping fish in an unhealthy aquarium is poisoning them, to give un nourishing food is starving them. You see you have two chances of killing your fish instead of one. If you manage your aquarium, I'll tend to the food—then you take no chances.

Robert J. Schaeffer

1818 Frankford Ave., Phila. Sample 10c

"AQUARIA FISH"

A practical work on care and breeding of fish in the Aquarium, Greenhouse and outdoor Ponds. Finely illustrated. Every one interested in keeping fish should send for a copy of this book. Price, \$1.

Four-Horned Snails (*Ampullaria Gigas*) deposit a mass of large coral red eggs out of the water, the little snails drop into the water as they hatch. These snails are invaluable for destroying Hydra in the aquarium.

Thoroughbred Collie Pups, beautifully marked.

F. L. TAPPAN

92 S. 7th Street, Minneapolis, Minn.

WALTER BELL

Breeder of **Broad-tail Telescopes**

BLUES BLACKS CALICOS

4324 WYALUSING AVENUE, PHILADELPHIA

Prices Reasonable

THE TERMINAL PET SHOP

PETS OF EVERY DESCRIPTION AND KIND

Manufacturing and Maintenance of Aquariums a Specialty

All Kinds of Cat and Dog Foods and Medicines

HUDSON TERMINAL BUILDING

Concourse, New York

TEN VARIETIES OF BEAUTIFUL AQUARIUM PLANTS

for \$1.00 Postage Postpaid

J. HENRI WAGNER, 1909 North Capitol
Washington, D. C.

VIOLET RAY FISH REMEDY

Relieves Constipation, Fungus, Tail Rot,
Congestion. Safe and effective. **Box of six
powders 25c.** For sale at Pet Stock Stores,
or address

REGENIA CHEMICAL CO., Sta. K, Philadelphia

"Everything is Fish that comes to the Net of a Naturalist"

Don't paddle in the water with one
hand and be blind with both eyes. In
other words, "keep your eyes open" for
all nature.

OUR MAGAZINE

The Guide to Nature

WILL HELP YOU

It is edited by EDWARD F. BIGELOW, who
fishes in the heavens and earth, as well
as the waters under the earth.

Single copy, 10c.

Four months' trial, 25c.

One year, \$1.00.

THE AGASSIZ ASSOCIATION

ArcAdiA

Sound Beach

Connecticut

I THANK YOU!

(as "K. C. B." would say) for the
hearty response to my "**Cut-Price
Fish**" ad. in a recent issue of "**Aquatic
Life.**" **A Few Choice Young Fish Left**

at prices ranging from 15c. apiece to
50c.—while they last! Send me a list
of what you have and see what I can
do for you.

NOW FOR SOMETHING STARTLING! A REAL FISH FOOD

NOT indigestible matter which poi-
sons your fish and fouls your aquar-
ium, causing gill fever, dropsy, consti-
pation and endless troubles—but truly
a "**Food for all Aquarium Fish** has
just seen the light of day, as the out-
come of twenty years' practical re-
search and experience.

"BEST-YET" FISH FOOD

(Reg'd Trade Mark) made by Brind—
from **Imported Ingredients.** No nasty
meat of warm-blooded animals, noth-
ing but **nutrition.** Sample box post-
paid, 12c. **Try it!** At the same time,
send \$2.60 for my **Book on Care and
Culture of Tropical Fish and Gold-
fish. Everybody needs it!**

W. L. BRIND, F. Z. S., 449 W. 206th St., New York
Telephone, St. Nicholas 8418.

Broad-tail Telescopes

Correspondence Solicited

GEORGE WILT, 1519 N. 62d Street

PHILADELPHIA

THE BRUCE FISHERIES

Breeder, Importer, Wholesale & Retail Dealer in

All Kinds of Goldfish

Comets a Specialty

ELGIN K. BRUCE, THORNBURG, IA.

FRANKLIN BARRETT

EVERYTHING COMPLETE FOR THE
AQUARIUM, POND AND LAKE

Wyoming Avenue, & C Street, Phila., Pa.

SEND FOR PRICE LISTS

ENCHYTRAE

The Secret of Successful Breeding of Tropical
Fishes and the Ideal Live Fish Food.

Portion, 50c (cash or money order) with Instructions how to breed them

CHARLES E. JENNE

109 22nd Street

West New York, N. J.

HALLER'S
Hartz Mountain Bird Store

Wholesale and Retail Importer and Dealer in
Genuine Hartz Mountain & St. Andreasburg

CANARIES

Gold Fish, Globes, Pigeons, Pet Dogs, Dog
Medicine, Poultry Supplies

Full Line of Best Imported German Bird Seeds Always on Hand
1108 VINE STREET
CINCINNATI, OHIO

HERMAN RABENAU, Aquarist

PERMANENT DISPLAY OF

Aquatic Life and Terraria

must be seen to be appreciated

Visitors Welcome

Plants and Tropical Fish a Specialty

Importations of New Varieties received
regularly

1163 Myrtle Avenue, Brooklyn, N. Y.
Near Broadway.

Nippon Goldfish Co.

1749 Buchanan Street, San Francisco, Cal.

Importers : and : Dealers

JAPANESE GOLDFISH

DIRECT FROM BREEDERS IN JAPAN

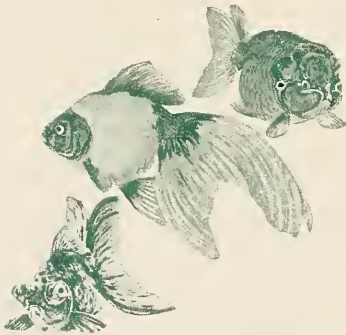

AWARDED GOLD & SILVER MEDALS

Panama-Pacific International Exposition
San Francisco, 1915

ALL KINDS OF AQUARIA AND SUPPLIES

Price Lists Furnished to the Trade Only

HARRY P. PETERS

1210 N. Warnock Street, Philadelphia, Pa

BREEDER AND IMPORTER

Rare and Fancy Fish

Plants of every variety, Snails and
Aquarium Supplies of all kinds at all
times.

MANUFACTURER OF

Green River Fish Food

10c a Box

Green River Baby Fish Food

15c a Box

A GOOD FISH FOOD is one of the
most essential things necessary to
keep fish in good health. After the
test of years Green River stands out
as the best food on the market. It
keeps the fish in good color by pro-
moting a healthy, robust growth. It
will not sour or cloud the water. Ask
your dealer or send for it today.

Young Veil-tail Goldfish

\$ 5.00 per Dozen and Up

A Splendid Assortment of Breeders

\$ 1.75 Each and Upwards

SHIPPING CAN, 25c EXTRA

HARRY P. PETERS, 1210 N. Warnock St.

Philadelphia

Otto Walter

86 Suydam Street :: Brooklyn, N. Y.

Near Evergreen Avenue L Station

Breeder and Importer of

TROPICAL AND GOLDFISHES

Telescopes Calicos Japs Fan-tails

Dealer in All Varieties of Aquatic Plants

All Kinds of Fish Foods

Fresh and Dried Daphnia

AQUARIA, UTENSILS AND SUPPLIES

50,938

March, 1917

10c Copy

Aquatic Life

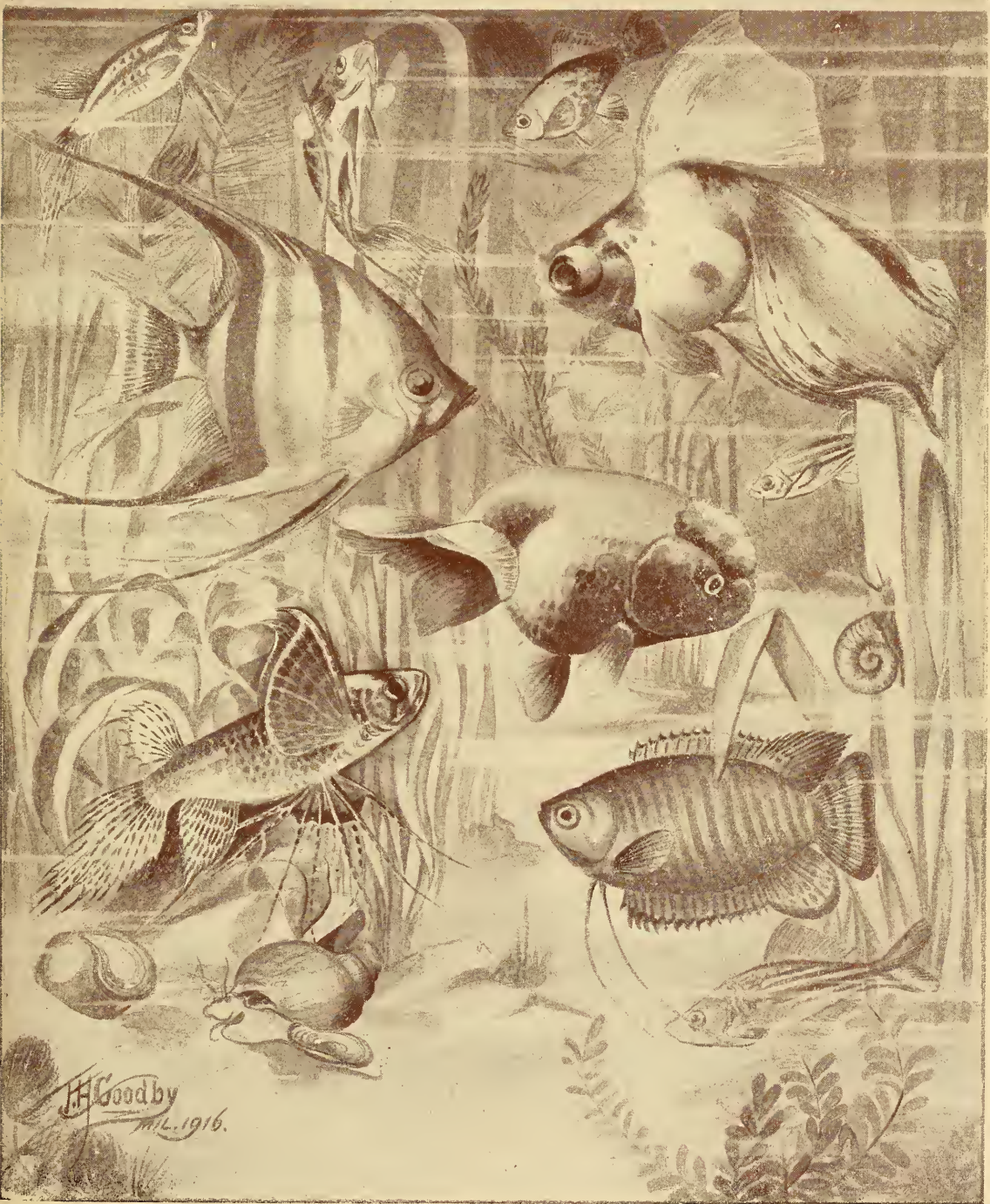

J.H. Goodby
M.L. 1916.

5

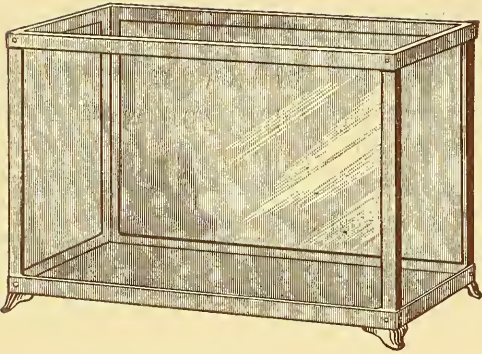

Jacob C. Cassel

915 Arch Street, Philadelphia, Pa

Manufacturer of

AQUARIUMS

Aquarium Ornaments

Floral Terra Cotta, Etc.

Goldfish Fish Globes Fish Food
and all aquarium requisites.
Send for Catalog.

Aquarium Specialty Co. 1873 WASHINGTON AVENUE NEW YORK CITY

MANUFACTURERS OF AQUARIA, FOUNTAINS, TERRARIA, VIVARIA
BREEDERS OF DOMESTICATED FISHES
IMPORTERS OF FOREIGN FISHES
AQUATIC PLANTS, SNAILS AND SUPPLIES

STOCK AQUARIA

Galvanized Metal Frame, Enameled
and Gold-Striped, Bottom Slate or
Ribbed Glass. Plain. On legs

No. 1.	11"x7"x7"	\$1.25	\$1.50
" 2.	14"x9"x9"	1.50	2.00
" 3.	17"x11"x11"	...	2.25	2.75
" 4.	20"x13"x13"	...	3.00	3.75
" 5.	24"x12"x14"	...	4.75	5.50

20% additional for oxidizing.

Solid Brass Frame, on Projecting
Slate Bottom or on Legs.

No. 1.	12"x 6"x 8" high,	2½ gal.	\$2.50
" 2.	14"x 8"x10"	" 5 "	3.25
" 3.	16"x10"x12"	" 9 "	4.75
" 4.	18"x12"x14"	" 14 "	5.75

20% additional for nickel-plating or
oxidizing.

Steel Angle Frame, Heavy Plate
Glass, Slate Bottom, Flush or Pro-
jecting.

No. 3½.	24"x14"x14",	22 gal..	\$8.00
" 4½.	30"x16"x16",	36 " ..	12.50
" 5½.	36"x18"x18",	54 " ..	20.00
" 6½.	42"x20"x20",	80 " ..	35.00
" 7½.	48"x22"x22",	110 " ..	60.00
" 8½.	54"x24"x24",	145 " ..	95.00
" 9½.	60"x26"x26",	180 " ..	135.00

All our aquaria are so constructed
that water cannot come into contact
with the metal.

All sizes and shapes made to order.
We charge only actual cost for pack-
ing and cases.

FISH FOODS

	Per Tin box.	Per lb.
Natural Fish Food....	\$.10	\$.50
Universal Fish Food...	.15	2.00
Ground Dried Shrimp..	.10	1.00

	Per Tin box.	Per lb.
Ground Dried Flies and Insects20	3.00
Ground Dried Daphnia..	\$.20	\$3.00
Infusoria Creating Food	.15	2.00

Correspondence Solicited. JOSEPH TAUBLES, Manager. No Catalogues

GOLDFISH SPAWN !

We Will Book Orders and Ship as Quickly as Obtainable in Tin-containers

Imported Japanese Fringetails	- -	\$2.50 for 100 Eggs
Calico Scaleless Japs & Telescopes	- -	\$5.00 for 100 Eggs
Black Telescopes Broadtails	- -	\$5.00 for 100 Eggs
Lionheads and Orandas	- - -	\$10.00 for 100 Eggs

We cannot fill orders for less than \$2.50, unless called for at our establishment

Large Stock of Fancy Breeders and 1916 Young for Immediate Delivery

AQUARIUM SPECIALTY CO., 1873 Washington Avenue, New York City

The Aquarium and Its Care

JOHN LEE BENNINGTON



PLANTS DOMINATE THIS SPLENDID AQUARIUM

Photograph by George H. Seip

The success of a self-sustaining aquarium (a better term than "balanced") depends upon the luxuriance of its plants. It is many years, more than fifty, since the discovery was made that plants under the influence of light give off oxygen. It is this process that makes the aquarium possible. Like the land animals, fishes breathe. The impure blood, heavily laden with the waste products of the body, is pumped to the minute veins of the gills, there coming in contact with the oxygen in the water, the waste being oxydized and cast off as carbon dioxide. The plants then take hold of this compound, break it up, retain the carbon which they need for building new tissue, and pass the oxygen back into the water; thus the oxygen practically acts as a carrier of carbon from the fishes to the plants. Plants breathe, too, of course, but the amount of oxygen they consume is comparatively small in relation to the quantity given off in tissue-building.

From the foregoing it will be understood that an aquarium will be self-sustaining just as long as the supply of oxygen from the plants is sufficient to meet the needs of the animal inmates. The old term "balanced aquarium" was wrong, in that it inferred that a state of equilibrium existed between the plants and fishes; if such was really the case the balance would be continually hovering between success and failure. This close correlation of the needs of the two forms of life cannot pertain. The plants must *dominate* in the tank, and must at all times be liberating more oxygen than the fishes will consume. If more than the water is able to retain, and the power varies with the temperature, it will be passed off into the atmosphere. Not so, however, the carbon dioxide. This is a heavier gas than oxygen, and more easily retained by the water.

As has already been explained, the real foundation on which the little water

world rests is the luxuriant growth of plants. Therefore, when considering a location for the aquarium, and by location is meant its permanent position with relation to the light, the demands of the plants must decide the question. Intense light will promote a strong growth of algae, which will form upon the plants

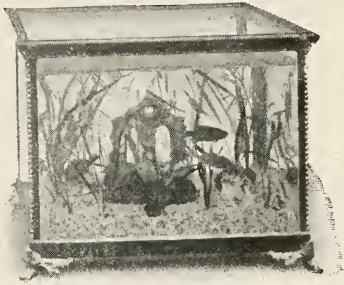

A Practical Small Aquarium
Photo by Wm. Mack

and retard their growth with a resultant decrease in the supply of oxygen. If the tank contains algae-loving exotic fishes, they may keep the plants fairly clean, but the goldfish will not touch it. Aquarists usually show a preference for a north window, with an eastern exposure as the next best; south and west are least desirable. If, however, the sunny windows are shaded by trees, and much of the direct rays cut off, or at least just allowed to filter through the leaves, then the south and west may become suitable. To recapitulate, place the aquarium where it will have good light, but not intense light, and little, if any, direct sunlight.

The most satisfactory tank is one having a metal frame, glass sides and a bottom of slate; the thickness of the glass and slate being in proportion to the size. If one intends to have but a single aquarium, a size holding fifteen to twenty gallons should be selected. Little need be said about the proportions, as the metal-frame tanks now made by the aquarists' supply houses are nearly all satisfactory in this respect.

When the tank has been placed in position, a few inches of water should be poured into it. Then a paste made of equal parts of whiting and table salt, slightly moistened with water, should be rubbed over the glass with the fingers; this polishes and cleans the glass. All traces should be removed by repeated rinsing.

Make certain that the table or stand selected for the aquarium is very strong—not shaky. The weight of even a small tank is considerable as a gallon of water weighs eight and one-third pounds.

A difference of opinion exists as to whether sand, grit or pebbles, or a mixture of all, is preferable for the bottom. The writer prefers coarse, white sand. This as purchased is rather dirty, and often will contain traces of mud and other soluble matter deposited in the bank from which it was dug. Careful

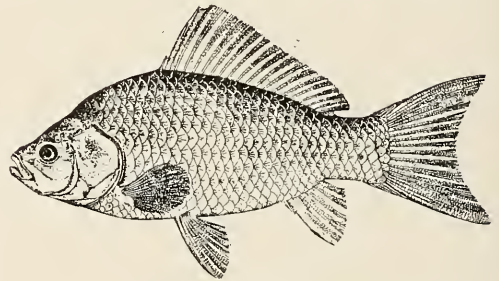

The Common Goldfish

washing in repeated changes of water is necessary if the water in the aquarium is to be crystal-clear. If the dry sand is sifted through a common wire tea strainer much undesirable matter will be removed; pebbles if wanted can be replaced. Now put the sand, a quart at a time, in a skillet or pan, place under a faucet and stir until the water runs off perfectly clear. During this cleaning process it will be well to scald the sand as an extra precaution. Spread the clean sand in the aquarium, arranging it an inch deep at the room-side, and two to three inches deep at the ends and win-

dow side. About six inches of water may now be added. The temperature of this water should be the same as that in the



Sagittaria natans

Drawing by Frank L. Tappan

receptable from which the fish will be taken; regulate the degree of heat by adding hot water to that in the pitcher or bucket, and not by pouring direct into the tank—the hot water would be apt to crack the glass.

We now have reached the stage wherein lies success or failure—the plants. The fault most general with beginners equipping their first tank is that they are niggardly when it comes to investing in plants. They will buy quite a nice tank, spend perhaps several dollars for fishes, but only a few cents for plants. In other words, they propose to build their water world on a very insecure foundation. The plants, the very essential to its success, they economize on; the greatest mistake it is possible to make in fitting an aquarium. It would be far

better if they regarded the aquarium as first an aquatic garden, and then, secondly, as a home for fishes.

There are just a few species of submerged plants that may be regarded as "foundation" plants. The first in this class is *Sagittaria* (several species or varieties), with *Vallisneria* a close second. The latter will thrive with considerably more sunlight than the former will find agreeable, but neither will thrive without sufficient light. Both are dominant plants in the tanks of experienced aquarists and propagate readily by means of runners from the roots. These species cost from ten to twenty-five cents per plant. The cost, considering the size of the individual plant, seems high, but as they increase in number more or less rapidly throughout the year, and are the best oxygenators in consequence, they are



Anacharis or Elodea

Photo by Henry A. Dreer

the cheapest plants in the long run. For the beginner's tank I advise about a dozen plants of *Vallisneria* or small *Sagittaria* to each square foot of bottom

area; if giant *Sagittaria* is chosen, then half this number, but the tank will do well if the kinds are assorted. In addition to these, to help while they are becoming established, use several bunches of *Anacharis*. The latter is an equally good oxygenator, and grows rapidly by a lengthening of the stem, but seldom branches—its only detrimental characteristic. It is necessary from time to time to cut off the tops of the stems and re-plant them, discarding the lower parts. I have had *Anacharis* reach a length of eight feet in a twenty-gallon tank, winding and rewinding about. To plant these species it is only necessary to thrust the roots or ends in the sand. The *Anacharis* may be tied loosely in bunches and placed in the corners; the other species along the window side and at the ends, leaving the front free for the observation of the fishes.

There are a number of other plants that may be selected, but they are "seasonable" and do not flourish at all times. *Potamogeton*, *Cabomba*, *Myriophyllum* and *Ceratophyllum* fall in this category. Other all-year plants, such as *Lugzwigia*, *Bacopa* and some of the mosses are difficult to grow at times, and are kinds to be considered after the tank has become well grown with the "foundation" plants.

The tank may now be filled with water to within an inch or two from the top; bury anywhere in the sand a block of plaster of paris an inch square, which will furnish shell-building material for the snails, or use the well-known "Regenia Salts," a preparation which replaces the solids absorbed from the water by the snails and fishes. Disentangle the plants with a slender stick of wood, arranging the stems and leaves in a free and natural way.

Much has been written as to the number of fishes that may be maintained in a given quantity of water. Some writers

have asserted that every inch of fish body requires a certain quantity of water. Such a statement may be either right or wrong—usually wrong. The number of fishes that may be kept in a given bulk of water hinges upon the foundation—the plants. With a dense growth of flourishing plants more may be maintained than if the plants are sparse and poor.

The greatest mistake of the beginner

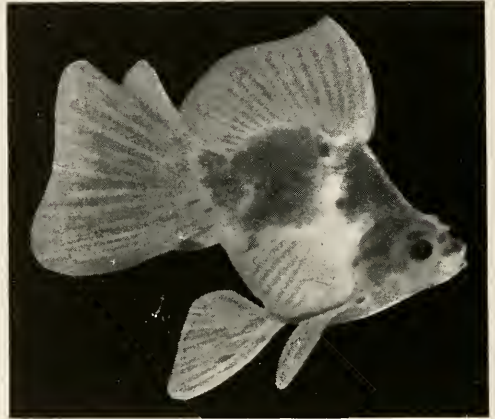

Jap Broad-tail Goldfish Nine Months Old When
Photographed by H. W. Schmid
Bred by George E. Wilt

is overstocking, and this is simply a way of expressing under-planting in a manner more easily understood. The tyro is impatient to see his aquarium teeming with fish life. The proper way is to begin with a few specimens, adding others from time to time until a safe maximum has been reached. This is a pleasurable way, and gives one time to become acquainted with each individual fish. The maximum capacity will be best determined by studying the actions of the fishes. When all is well they will be swimming in all parts of the tank, and doing almost anything but remaining persistently at the top, taking the surface water. We are, of course, considering over-crowding symptoms, and not actions

that may indicate disease. Regardless of the size of the aquarium, begin with just a few fishes; if it holds twenty gallons, get half a dozen with bodies two inches long, a dozen or even two dozen if half this length. Thereafter, the plants having increased in size and number, others may be added, but at all times bear in mind that the fewer the fishes at all times the more rapid will be their growth individually, and inversely, the more the fishes the slower they will grow, if indeed they grow at all.

I keep snails, lots of them, in my tanks, not because I believe them to be important scavengers, as is usually claimed, but because I find them an interesting study. In a twenty-gallon tank one may have a dozen red snails (*Planorbis corneus rubra*), a dozen African snails (*Lymnaea auricularia*), half a dozen Japanese snails (*Viviparus malleatus*) and a few of the small, native wild species. As to tadpoles, I absolutely will not have them as scavengers. The little good they work is more than counterbalanced by their delight in squirming about the bottom and stirring up the sediment that is sure to accumulate.

If it has not already been understood, this article concerns the aquarium containing goldfish; for tropical fishes modification would be necessary in several places.

The mainstay of our pets is the so-called prepared food; many brands, and good ones, too, are offered by "Aquatic Life" advertisers. It is my plan, in common with others, to secure a number of kinds and mix together. Again, I may keep them separate and fed in rotation. Either way is good. Now, even fishes like variety, and find it in nature, so it is necessary at intervals to depart from the staple. The most pleasing tidbit will be daphne—you need never worry about other foods if you have it,

and you may gather it yourself or buy it from the nearest fancier. Occasionally feed each fish a particle of earthworm; impale on a broom straw and feed individually, that each may get its share. Do likewise with maggots, tiny scraps of lean, raw beef, bits of oyster in winter and clam or mussel in summer, using the soft parts. To summarize, use good prepared foods as the staple, then every other day treat the fishes with one of the delicacies mentioned. Regarding

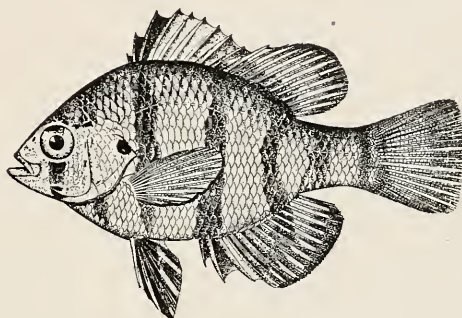

**The Black-banded Sunfish
May Be Kept With Goldfish**

quantity, feed as much, and only as much, as will be consumed immediately or within a period of ten minutes. This applies to all foods except daphne, which, being alive and active, may not all be consumed for hours.

The most important suggestion that can be made in connection with the management of the aquarium is to let it alone; don't "monkey" and "fuss" with it *unnecessarily*. With the exception of feeding it can run along for considerable intervals without assistance. Occasionally it will be necessary to remove the sediment from the bottom with a dip-tube, and to remove with a clean piece of muslin the algæ that will form upon the glass. You may remove a decayed plant or leaf, or replace one that has been uprooted, and, as happened to the most experienced aquarist, you will segregate a fish that shows signs of illness; and

such should be taken out *pronto*, lest the infection be contagious. Once a month, with a rubber hose, syphon out a bucket of water and replace with new water of the same temperature. Through the winter endeavor to keep the tank at a temperature between 55 and 60 degrees Fahrenheit; in summer take what comes, though you must avoid, as before recommended, the direct sunlight that will during the day raise the temperature to a

ternal. Some are curable and others not. A few have obvious symptoms that are readily recognized, while internal afflictions cannot be diagnosed except by a post-mortem examination by an experienced anatomist and bacteriologist.

Most investigations of fish diseases have concerned the food and game species, their economic value justifying the great expenditure of time and money. Much has been accomplished, but much

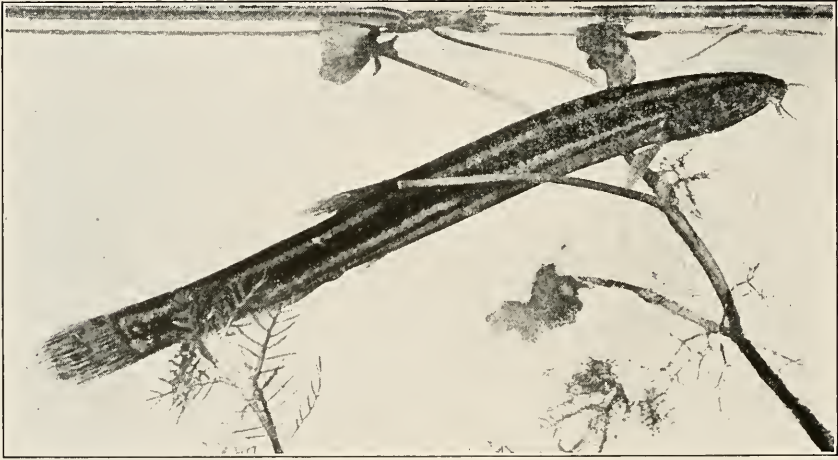

The European Weatherfish, *Cobitis*, is a Useful Scavenger

point causing discomfort if the tank be small.

Few exceptions will be found to my remarks, and, in general, let the aquarium "mind its own business," and only offer assistance when it seems to need help to preserve peace and health; even neglect cleaning and all else but feeding, unless the tank is becoming unsightly and needs "brushing up."

The fish is a complex organism and is subject to a wide array of diseases, parasitic and non-parasitic, internal and ex-

ternal. The efforts of the laboratory of the Regenia Chemical Company, however, have been exerted in the interest of the aquarium fish, with the result that "Violet Ray" is now the standard remedy of the aquarist, having superceded the salt bath and other simple nostrums.

As a pure breed the Fantail goldfish has long been extinct, having been merged by cross-breeding into the fringetail form. fantail is the popular lay term for double-tailed fish generally, and as such is used in dealers' price lists.

Breeding and Rearing Goldfish

JOSEPH E. VAN STAVERN

Photograph by H. W. Schmid

The goldfish is oviparous; that is, the eggs are expelled by the female before fertilization, which takes place immediately after delivery. Unlike some other fishes, all the eggs do not develop together, but in lots so to speak. A female may spawn several times during a season, the frequency of the operation varying with her fertility and vigor. The preferred breeding season, which means that the ensuing months will be most favorable in weather conditions and natural food supply, extends from March to July. Earlier and later spawns will meet conditions unfavorable to rearing.

The first indication of the approach of a spawning operation will be the action of the male in driving a gravid female. Then it will be noted that she is swollen with eggs, and that he exhibits the characteristic tubercles or tiny spots on his pectoral fins and gill-covers. Fancy goldfish are not usually bred in pairs. If the fish are alike in size two males, or three if the males are smaller, are used with one female. This insures against unfertile eggs should one of the males become exhausted before the female stops spawning. The selected trio should be placed in a small tub or a large enamel dishpan, with three or four loose bunches of *Myriophyllum* or an equal number of water hyacinths with long, bushy roots. Spawning may then be expected, and usually occurs during the early morning hours. The males drive the female persistently through the plants, and with a sinuous side-to-side movement they assist in the expulsion of the eggs and fertilize them. The eggs resemble tiny golden

spheres, about the size of the head of an ordinary pin. The fish should be removed when they cease to drive.

The eggs will hatch in a period varying from three to eight days, according to the temperature of the water, which



Calico Telescope Goldfish
A female about to spawn
Owned by George Wilt

should be not less than 60 degrees. When the fry appear they seem to be all head and eyes, carrying a large ball on the under side. This protuberance, seemingly so disproportionate to the size of the tiny creature, is the yolk-sac from which the young fish absorbs its first nourishment. This disappears in a few days, and the youngster seeks the animalcules or infusorians now necessary. At this stage of its career growth is rapid

and it is soon able to eat the tiniest daphne, and from this time on it should never be without this succulent morsel. However, before the daphne is used some breeders feed the yolk of a thirty-minute boiled egg, mixing it with a little water and straining it through fine lawn or cheese-cloth. It must be used cautiously lest the water be polluted. As the fish grow they may be occasionally fed a little boiled oatmeal, to which a little shrimp or shredded codfish has been added; mosquito larva if available will be equally as good as daphne.

The growth of the fish will not be dependent solely upon the foods, but

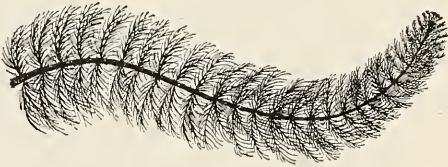

Myriophyllum

equally upon the water space. The more room they are given the quicker and more vigorously they will grow. To this end they should be sorted frequently, according to size and individual perfection, and the least desirable ones discarded. Those who breed in great numbers use oblong tanks of wood, but the beginner will do well to get a battery of ordinary wooden wash tubs of the largest size, that hold about twenty gallons. These may be placed in a row and supplied with water from a pipe having a pet cock for each tub. A length of small rubber tubing should lead from each cock to a tub, and a mere trickle of water allow to run at all times. If it is not possible to run the water constantly, then at least some new water should be added to each tub daily.

When the youngsters have reached a length of an inch not more than twenty should be in a tub; half this number

when two inches long—body length. Any attempt to crowd will surely reduce the rate of growth.

Dr. Tarleton H. Bean died at his home in Albany, N. Y., on December 28th, after an illness of six weeks, following an automobile accident. Dr. Bean became connected with the United States Fish Commission on January 1st, 1875, and served for many years as scientific assistant and ichthyologist. In 1892 he became chief of the division of fish culture, which position he held until 1895, when he resigned to become director of the New York Aquarium. Since 1906 he has been fish culturist of the State of New York.

Mr. A. Volmer, of the Chicago Aquarium Society, reports having eggs of the four-horned snail, *Ampullaria gigas*, hatch in eleven days. This is somewhat shorter than the minimum period of incubation usually mentioned.

The comment of Mr. N. M. Grier, in his "Aquarium Notes," January number, that *Anacharis* has been known to cause the death of snails, is most unusual, and surely is based on faulty observation. I raise large numbers of snails in cement tanks and aquaria that are filled with this plant, and with little or no loss.—*Oscar Leitholf*.

When a friend deals with a friend, let the bargain be clear, that they may continue friends to the end.

The heart of a fish lies just under the throat and is composed of but two cavities, whereas that of the higher animals has four.

Nature ever yields reward to him who seeks, and loves her best.—*Cornwall*.



THE KITEFISH

C. J. HEEDE

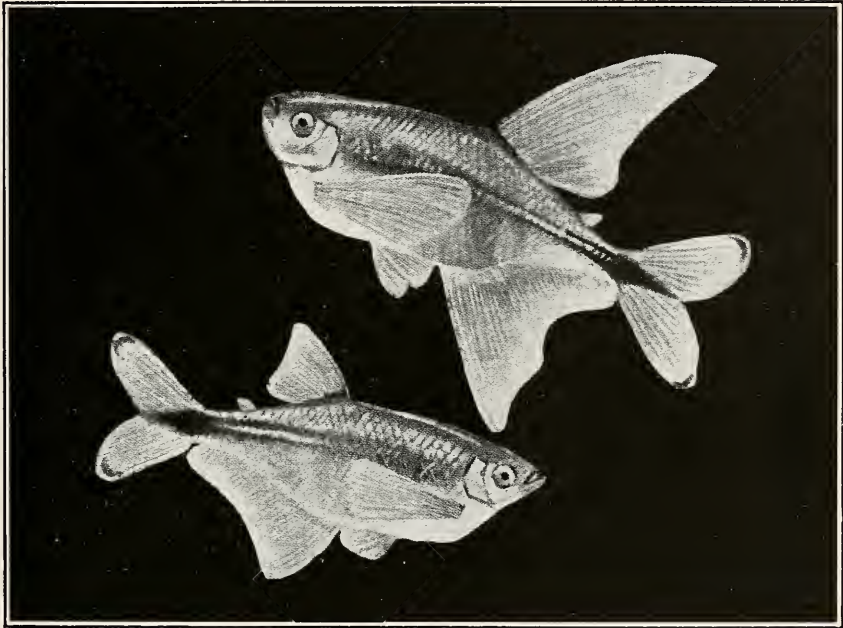

Pseudocorynopoma doriae

The Kitefish

Among our many aquarium fishes none is so appropriately named as the Kitefish, *Pseudocorynopoma doriae*. This member of the Characin family is a native of the Amazon, La Plata and tributary waters of South America. It first became known to aquarists about ten years ago.

The general coloration of the species, when viewed in bright, direct light, is iridescent bluish green; upper portion of body, olive to brownish on the back; abdominal region rich silver; silvery blue or violet line runs from behind head backward to a dark spot at the tail; dorsal and anal with dark spots; outer area

of tail fin is cream color; adipose fin pinkish. The female lacks the fin development of the male. The male is lively, graceful in movement, and will dance the "tango" and "fox trot" to win the favor of his spouse.

The breeding habits are much like those of *Danio* and *Tetragonopterus*. The eggs, to the number of 800, are expelled in one day. They are non-adhesive and lodge among the plants or fall to the bottom. The period of incubation ranges from twelve to forty-eight hours. For a few days after hatching the fry are attached to plants by a slimy thread connected to the back of the head. When

three to four months old the youngsters are able to breed, the males being distinguished by the fins, though they are not fully developed until after the individual has bred. The maximum size is two and one-half to three inches.

After the extrusion of the eggs the adults should be removed to another tank, as otherwise they will devour the spawn. It is well to protect the eggs, using the methods followed when breeding *Danio*. The young require abundant Infusoria, and later Daphne and the other live foods.

The Kitefish demands clear, clean water, which should be frequently renewed, and a good-sized aquarium. It should not be closely planted, or at least a portion left free of vegetation. The tank should be maintained at a temperature of 65 to 75 degrees Fahrenheit—above or below is detrimental to their welfare. The temperature of the average living room is about right. During the summer months it can be kept in outdoor ponds in localities where the proper temperature pertains.

Infusoria Culture

The first food taken after the absorption of the yolk-sac by fry of egg-laying fishes is termed, by the fish breeder, infusoria, his collective name for the protozoans, which are the most primitive forms of animal life and the smallest, all being microscopic, and even the largest scarcely discernable by the unaided eye. Members of the group may be found in any puddle of water, even in a transient pool in the city gutter. How they have appeared in such pools explains why it is possible to produce them at will for fish food.

When a pond becomes dry the animalcules form resting bodies or spores, in which condition they may be wafted

about by the wind, and finally find a suitable environment for development in another body of water. This characteristic, called anabiosis, or state of lifelessness, has been known for two hundred years, and still awaits a satisfactory explanation. The fish breeder takes advantage of the phenomenon when he gathers submerged aquatic plants, dries them in the sun, and stores them away to produce the animalcules at will by merely placing the powdered plant remains in water. The resting bodies become active and reproduce, meanwhile feeding upon the vegetable matter. In view of the slight cost of the prepared material, which may be had from The Aquarium Specialty Company, it scarcely pays the average fancier to collect the plants and make it himself.

Just a Thought

A gentleman fish fancier is a man who is clean both inside and outside, who neither looks up to the rich nor down to the poor; who can lose without squealing and win without bragging; who is considerate of fellow fanciers; who is too brave to lie, too generous to cheat, and who takes his share of the cups and ribbons awarded at the show, and lets other people have theirs.—*Aqua-pet*.

From the Land of the Dells, the state made famous by its many products—malted milk and the malt without the milk—comes the gladsome tidings of the launching of the Platteville Aquarium Society, of Platteville, in Wisconsin. Alfred B. Krog is president; F. R. Webber, secretary; Frank K. Burg, treasurer. The society will meet in Platte-pocilia Villa, and much will accrue to the advantage of those who attend.

Please send *AQUATIC LIFE* for another year. It is fine.—*C. C. Gross*.

Minute Inhabitants of Aquaria

PERRY BRUCE CLARK, San Francisco Aquarium Society

The rotifers, or wheel animalcules, are very interesting animals, very transparent, and their structure is easily seen with a microscope. They are small, measuring one-thirtieth of an inch, but are highly organized. Circular discs at the anterior or mouth end, from which project a row of cilia which are in constant motion, greatly resemble revolving wheels. These cilia or hairs sweep the food into the mouth, and also serve as propellers for swimming. It may also move after the manner of the so-called measuring worm by loping, that is, attaching the head and then moving the tail up to it. The rotifers multiply by means of eggs. It has been stated that these eggs are very resistant, and may under favorable conditions develop after having been in the dry state for a number of years. At times rotifers may be collected in quantity and form a valuable food for fish just out of the egg.

Nearly all the live foods used for young fishes belong to the class Crustacea, which contains some very small animals, as well as some large ones. As the name implies, they are shell-bearing animals. The body is segmented, though in some of the smaller species it is very indistinct. In this class belong the lobster, crab, shrimp, crayfish, and smaller forms such as *Gammarus*, *Daphnia*, *Cyclops* and *Cyprid*. Of these the best for fish food is *Daphnia*, the body of which is flattened, indistinctly segmented, and enclosed in a bivalve carapace or shell. The prominent antennae give it a bizarre appearance as it jerks its way through the water; they look like abnormally long arms waved above its head. It multi-

plies rapidly in a very curious manner. During the summer the female produces eggs, which, without fertilization by the male, mature in the brood pouch into perfect animals in about four days. A

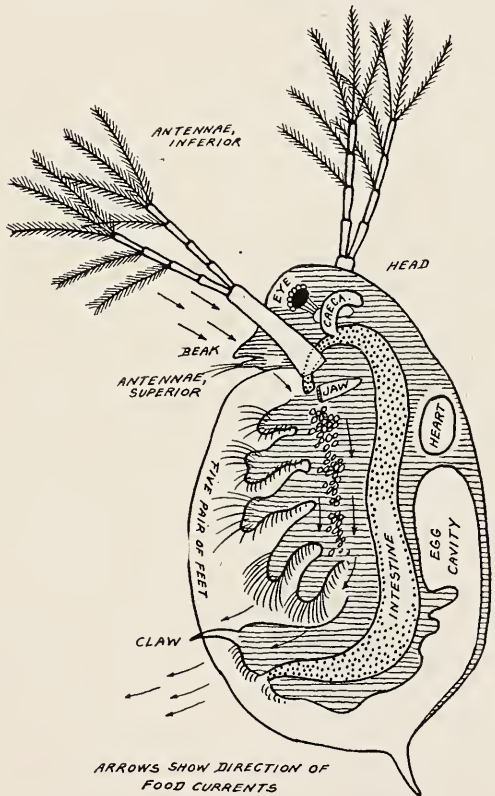

Daphnia pulex (greatly enlarged)
Original Drawing by Frank J. Myers

few days after leaving the mother they, too, reproduce in like manner. In the fall of the year the much smaller males appear, and then sexual reproduction takes place. The female now lays winter eggs, having a thick covering, which protects them through the cold months until they hatch. *Daphnia* live upon decaying

vegetable matter and small infusorians. It has been stated that very young fish will follow a female to catch the young as they are liberated.

Another food crustacean is *Cypris*, though it is not as desirable as *Daphnia*. It has a hard bivalve shell and in consequence is sometimes called the hard-shell water flea. Its movements are slow, and even either in swimming or crawling over the bottom. The young are developed

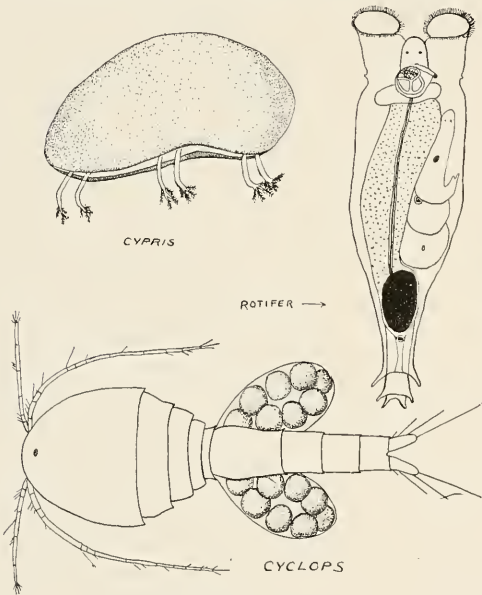

Drawings by Author

in a brood pouch, but, unlike the *Daphnia* are not fully mature when expelled. It multiplies even more rapidly than *Daphnia*.

Every aquarist knows *Cyclops*. It will appear in most any aquarium that has been standing for a time without fishes. It has a long, tapering body, ending in two thin, sharp appendages; a single eye in the centre of the head; two long antennæ used for propulsion. The female bears two egg-sacs, each containing about twelve eggs. The young mature in about fifteen days, and themselves bear eggs. The female will develop egg-sacs every few days.

The fairy shrimp, *Gammarus*, rarely exceeds half an inch in length. In structure it resembles the ordinary shrimp, being a more highly organized crustacean than the others discussed. It has two ways of moving through the water, swimming and hopping, although it usually swims. The large ones are very destructive to young fishes, but the young shrimps serve as good fish food.

It is regretted that space does not permit a discussion of more of these interesting little animals. There are so many that it would take a large book to describe and illustrate them. It is to be hoped that these articles will arouse interest in the many minute forms of aquatic life that heretofore the aquarist has only regarded as food for fishes, neglecting to study them from other than an economic standpoint.

The Essex County Aquarium Society, Newark, has elected the following officers for the year: President, Max G. Hammerschlag; vice president, G. W. Ludolf; treasurer, Dr. William Bachmann; secretary, William Feldman, 214 Runyon street, Newark, N. J.

The society celebrated its first anniversary on February 3d with a smoker-entertainment. Twenty new members were initiated. The meetings are held on the first and third Friday of each month, at the Newark Turn Verein Hall, 186 William street, Newark, N. J.

At the January meeting of the Boston Aquarium Society, Chief Deputy Game Warden Orrin C. Boume delivered a lecture on the work of the Fish Commission of Massachusetts. The talk was illustrated by lantern slides of the various fishes of the State, and scenes showing methods of culture and distribution.—*Walter H. Chute, Secretary.*

Sex Identification of Goldfish

F. BAMFORD HANNA

Quite the first question to be asked by one desiring to breed the goldfish is how the sexes may be distinguished. It has been shown that a slight difference in contour exists in the region about the anus, but it is exceedingly hard to discern, and not a few experienced fanciers will refuse to guarantee the sex of a fish based on this feature alone. This variation between the two sexes is clearly shown in the accompanying illustration, but is not nearly so plain on the fish as on paper:

When in condition to breed the distin-

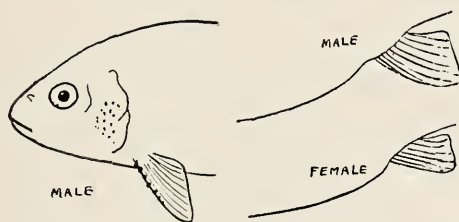

guishing points are very evident. The male develops tubercles or "salt spots" on the gill plates and along the first ray of the pectoral fins. These marks may be absent from the fins, and but few in number on the gill plates. The tubercles are usually considered an infallible distinction, but are not absolutely so. Once in a lifetime a fancier may find a female with tubercles! George W. Price and William L. Paullin have reported instances.

The female, except about the anal, exhibits no sexual distinction until the development of the roes cause a distention of the body, which is more evident from a top view than from the side. Other than this, it possesses no characters to distinguish it from the male. If both sexes are in the same tank, precocious males may "drive" barren females, and

in that manner aid in identification, but a doubt may be cast on the certainty of it by the fact that males will sometimes drive other males.

Pond Culture of Daphne

OTTO GNIEDING

Inasmuch as I rear from ten to fifteen thousand fancy goldfish in ponds having an aggregate area of about ten thousand feet, it can be realized that in past years it has been quite a task to provide my fish with the necessary Daphne in abundance. This has meant frequent and distant excursions, not to mention the great amount of time consumed. Last year I determined to have my own Daphne pond, and to this end, having ample ground at my disposal, I set aside a space measuring thirty by forty-five feet, and excavated to a depth of two and one-half feet.

About the middle of February I bought a quart of soy beans, giving them to a farmer to plant in his hot-beds. By April 15th, the plants having grown rapidly, were fifteen inches high. I pulled up about a fourth of them as being sufficient for my purpose, and took them home. Meanwhile I had been to see a Japanese merchant who imports bric-a-brac, which comes from Japan packed in rice-bran—the very material I was searching for. I secured several bags of it without cost. I was now ready for the real work.

My pond was perfectly dry at this time. In the centre, covering an area three by six feet, I laid horse manure to a depth of about three inches; over this I distributed my soy-bean plants; then a quantity of lean meat secured at little cost, being only fit for dogs; next the rice-bran six inches deep; finally all was covered with fresh horse manure. On

Aquatic Life

A monthly magazine devoted to the study, care and breeding of native, tropical, gold and fancy fishes, other animals and plants in the household aquarium.

W. A. POYSER Editor
 JOSEPH E. BAUSMAN Publisher
 542 E. Girard Avenue, Philadelphia.

Entered as second-class matter, September 2, 1915, at the Post Office, Philadelphia, Pa., under Act of March 3, 1879.

Yearly Subscription\$1.00
 Foreign Subscriptions 1.35
 Single Copy10 cents

Payments may be made by express money order, draft, post office order or registered letter. Foreign remittances should be by international money order.

Advertising rates made known on application. "Aquatic Life" is the only magazine in America devoted exclusively to aquatic life, and its value as an advertising medium in this field of nature study is unequalled.

Copyright 1917 by Joseph E. Bausman

Vol. II March, 1917 No. 7

the mound thus formed I spread a piece of poultry wire netting, pinning it down with large stones. It was my intention to leave it thus for about two weeks, but on the eighth day it rained, and the pond filled to a depth of eighteen inches.

The first sign of life appeared twelve to fifteen days later, and within four weeks I had, to my great satisfaction, an abundance of the much-to-be-desired Daphne. I had plenty of them during the entire season, not only for my large stock of growing fish, but also for my many customers.

The regular meeting of the Philadelphia Goldfish Fanciers' Society was held in Saull's Hall, 802 Girard avenue, on February 21st.

Ribbon-tail Japs and telescopes were shown in competition. The following decisions were given by the judges,

Messrs. Elmer C. Hazlett, Charles Hinkle and James Fleming:

Scaleless Japs—Blue and red ribbons, Gustav Armbruster; yellow, Francis X. Garcia.

Scaled Japs—Blue, William Hartman; red, Albert P. Miller; yellow, Joseph E. Tyler.

Scaleless Telescopes—Blue, William Raroha; red, Dr. F. C. Leffman; yellow, Joseph E. Tyler.

Scaled Telescopes—Blue, Howard E. Demuth; red, Gustav Armbruster.

New members elected—John Kershner, William Himmershitz and F. Cassey, Jr.

The next meeting will be held March 21st. Competition for telescopes bred in 1916. The "Board of Directors cup" and six ribbons to be awarded.

Fred Richardson, Secretary.

A few of us here are much interested in the aquarium, and think we have some fine stock—mostly purchased from fanciers who advertise in "Aquatic Life." Every one admires my office aquarium and comments upon the fishes, which most people here had never seen before.—*Russell T. Neville.*

I have had a very successful season breeding goldfish, paradise fish, and six species of exotic fishes, having started to collect my fishes and build the equipment a year ago. Helps and hints taken from AQUATIC LIFE from month to month in the greatest measure were responsible for my success.—*Carl Braun, Jr.*

The Union of South Africa, China and Australia have recently been added to the constantly growing list of foreign countries in which AQUATIC LIFE finds readers.

Nets and Sieves

Spawning Net.—Designed for the goldfish breeder having limited tank space. The cheese-cloth bag, weighted with lead "sinkers" in the lower corners, is tied to a frame of wood, which rests on the edges of the aquarium or tank. When spawning seems imminent the males and female goldfish, together with

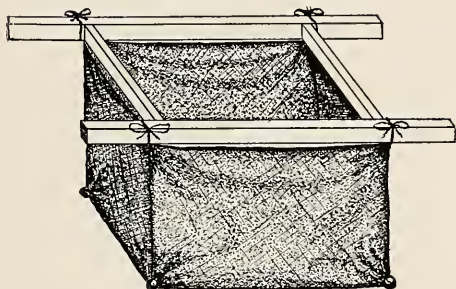

Spawning Net

a quantity of plants, are placed in the net. When the operation is completed the fish are returned to the aquarium and the plants placed in a pan and not removed until the eggs have hatched. The net

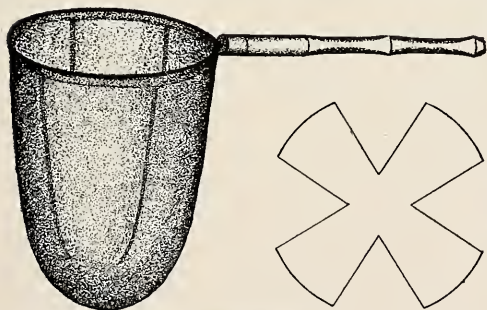

Daphne Net

measures twelve by twelve by eighteen inches.

Daphne Net.—A heavy spring-brass wire loop inserted into the end of a six-foot bamboo rod, protect the end of the rod with a brass ferrule to prevent splitting. Make the bag from a square yard of cheesecloth or fine lawn, cut along the lines of the pattern shown. For general collecting in open water free from debris

the loop may be eight inches in diameter, with a bag twelve to fifteen inches deep. For removing daphne from the home storage tank a net with a four-inch loop and a twelve-inch handle will be found convenient.

Food and Daphne Sieves.—It is almost impossible at times to gather daphne without catching obnoxious insects or their larvæ. Several frames six to eight

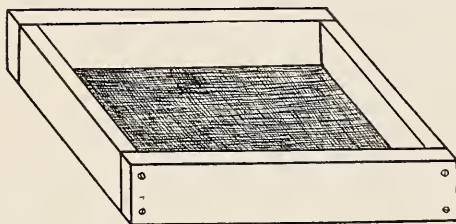

Food and Daphne Sieve

inches square should be made from wood one inch thick by three inches wide, and brass wire cloth closed tacked to the bottom. Cloth of coarse mesh, twelve to an inch, will pass nearly all daphne and

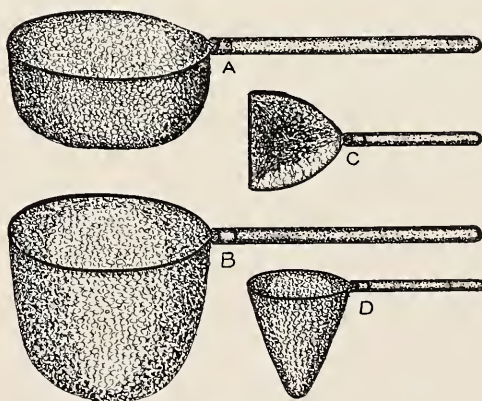

Aquarium Nets

retain the insects; twenty-mesh will pass small daphne desirable for very tiny fish and retain the larger, which may be fed to the adults. A still closer mesh will at times be useful. These sieves may be used to grade dry ground fish food into sizes suitable for fish of differing ages.

Aquarium Nets.—All with loop of

spring-brass wire and wooden handles of convenient length—twelve to fifteen inches. Goldfish should be handled in the broad, shallow type A; tropical and natives species in B; form C is similar, but has a triangular loop. The deep funnel D should be avoided. Fine bobbinette is the best material for the bag.

Egg Congestion

J. LOUIS TROEMNER

Last autumn I lost a very good Calico Telescope goldfish, death having been caused by egg congestion; she was egg-bound, in common parlance. The fish was hatched in May, 1915. Before she was a year old she began to "fill out" with eggs, and in June, 1916, her roes were so heavy that she began to pitch slightly to one side, as is so often the case. Although I tried all the tricks usually resorted to in such cases, I could not induce the fish to spawn. I was afraid to attempt stripping her, for, although I have seen it done, I have never undertaken it myself, and I rather feared that the fish might be injured. I consulted one of our local aquarists, thinking there might be some method of relief that I had overlooked, but he assured me that little could be done to relieve the condition, and that it would be safer to let nature take its course and me my chances. That was about July. The fish lived throughout the summer, but did not spawn, and in November I found her dead, almost in a normal position, but still slightly pitched to one side.

I opened the fish and carefully removed the roe. The body, without the roe, weighed 13 grams and 650 milligrams; the roe alone weighed 10 grams and 850 milligrams. Note the comparison. The eggs were almost half of the total weight of the fish, and this development was at its height in July, the fish

then being just a few months over one year old.

The favorite "Guppy," *Lebistes reticulatus*, was exhibited in competition at a recent meeting of the Chicago Aquarium Society. The championship and blue ribbon was won by Fred G. Orsinger; red

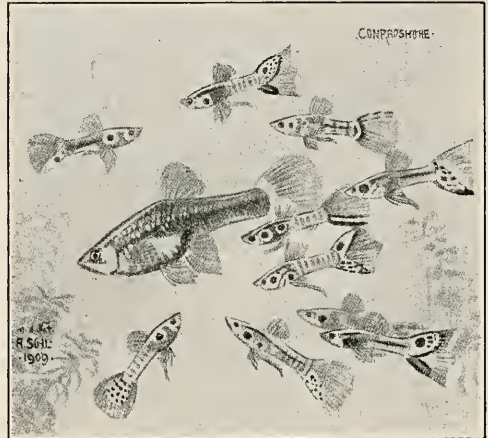

Lebistes reticulatus
The Rainbow Fish or Guppy

ribbon, William Hitchcock; white ribbon, Fred Buchholz, Jr. Judges, Floyd S. Young and St. Elmo Linton.

While goldfish and some others can adapt themselves to water 100 degrees F. on one hand and to 33 degrees F. on the other, only asking that the change be gradual, it should not be overlooked that the high temperature is apt to cause grave complications resulting from putrefactive conditions within the intestines of the fishes and in the water. Cold water has a greater power to retain oxygen.

The woman who constantly carries around a magazine is not always a great reader. Sometimes the magazine—unless it happens to be AQUATIC LIFE—contains her embroidery silk.

THE AQUARIUM AND TERRARIUM LIBRARY

The progressive aquarist and nature lover should have in the home library all books pertinent to his interests. We suggest the following and will be glad to quote price on any book in print

The Home Aquarium and How to Care for It. A guide to its fishes, other animals and plants. By Eugene Smith. 213 pages, 137 illustrations, cloth binding, \$1.20. Add parcel postage on two pounds.

Japanese Goldfish. A guide to the Japanese methods of culture. By Dr. Hugh M. Smith, U. S. Commissioner of Fisheries. 10 full-page colored plates, numerous text cuts, 112 pages, cloth binding, \$2.00. Add parcel postage on two pounds.

The Freshwater Aquarium and Its Inhabitants. A practical work for the aquarist. By Egging and Ehrenberg. Freely illustrated, 332 pages, art cloth binding, \$2.00. Add parcel postage on two pounds.

Magazines. Nearly every household subscribes for a number of magazines. We are prepared to quote on any combination of periodicals, regardless of class, and to meet or beat the offers made by any subscription agency. Subscriptions may be new or renewals, and may date from the current or future number with which your present subscription expires. Combinations may include Aquatic Life if desired.

Aquatic Life Binder. We now furnish an attractive, substantial, full cloth binder that holds 24 numbers of Aquatic Life—the issues of two years. One copy is held as securely as a dozen, and all are together for ready reference at any time. When a volume is complete it can be removed for permanent binding, and the use of the binder continued for current numbers. The binder costs \$1.35, postpaid; with yearly subscription, new or renewal, \$2.00. Renewals may be made at any time in advance of expiration.

Making a Water Garden. William Tricker. Water gardens are gaining in popularity. This book tells how to make and care for them. 52 large pages, 10 illustrations, cloth. 50 cents. Add parcel postage on one pound.

The Frogs. M. C. Dickerson. The North American Toads and Frogs, with the habits and life-histories of those of the northeastern States. 253 pages, 16 colored plates and 300 photographs from life. A companion volume to the book of Reptiles. \$4.00. Add parcel postage on four pounds.

Shells of Land and Water. Frank Collins Baker. From this interesting volume you will learn how the snails and other mollusks live, and where to collect them. 182 pages, illustrations of 82 species in natural colors and numerous half-tone and line engravings, cloth binding, \$2.50. Add parcel postage on three pounds.

How to Know the Mosses. E. M. Dunham. A popular guide to the mosses with descriptions of 105 species of the northeastern U. S. Will answer many a question which a walk in the woods suggests to the nature lover. Profusely illustrated, 274 pages, cloth, \$1.25. Add parcel postage on two pounds.

Turtles, Snakes, Frogs, other Reptiles and Amphibians of New England and the North. Edward Knobel. 50 illustrations, 48 pages, paper cover, 50 cents. Add parcel postage on one pound.

The Reptiles. Raymond L. Ditmars. A popular work on the turtles, tortoises, crocodillans, lizards and snakes of U. S. and Mexico. A book for those interested in the terrarium. 472 pages, 8 colored plates and over 400 photographs from life. \$4.00. Add parcel postage on four pounds.

Goldfish and Its Culture. Practical instructions for pond breeding, shipping, care of the aquarium, and the general subject. By Hugo Mullertt. 155 pages, 15 illustrations, cloth binding, \$2.00. Add parcel postage on two pounds.

Food and Game Fishes. Jordan and Evermann. An account of the food and game fishes, habits and methods of capture, etc. 331 illustrations, 572 pages, cloth, \$4.00. Add parcel postage on five pounds.

Fish Culture in Ponds and Inland Waters. The most recent book, covering the propagation of goldfish, food and game fishes, and aquarium management. By William E. Meehan, Director of the Fairmount Park Public Aquarium, Philadelphia, and former Pennsylvania State Fish Commissioner. 287 pages, 22 illustrations, cloth binding, \$1.00. Add parcel postage on one pound.

Life of Inland Waters. Needham and Lloyd. A big book containing 458 pages and 244 splendid illustrations. It presents a survey of the whole realm of freshwater aquatic life. The only American publication on the subject, and one that will materially assist the aquarist in solving the many problems encountered. \$3.00. Add parcel postage on three pounds.

Everyman Encyclopaedia. Edited by Andrew Boyle. A work serviceable to every man or woman who wishes up-to-date accurate information in compact form. Particular attention has been given to scientific, historical and literary data. 12 volumes, 7680 pages, 1200 illustrations, cloth, \$8.00. Add parcel postage on twelve pounds.

AQUATIC LIFE BOOK DEPARTMENT

Publications on the Sciences, Arts and Trades

542 E. Girard Avenue

Philadelphia

OSCAR LEITHOLF

433 Fourth Avenue, Pittsburgh, Pa.

TROPICAL FISHES

PLANTS :: :: SNAILS

Planorbis corneus Var. rubra

Paludina vivipara

Write for Price List.

Aquarium: 281 Southern Avenue.

Goldfish Spawn

From Choice Telescopes and Japs

\$2.00 per 100 Eggs

I. X. L. Regular and Baby Fishfood,
10c. Box.

W. E. WALP

1309 NORTH 55TH STREET,
PHILADELPHIA.

W. M. STUART

Dealer in Curios, Indian Relics, Stamps,
Jewelry, Genuine Gems, etc. Send 25 cents
for catalogues of rubber stamps, sample per-
fumes and fine handcraft jewelry.

Marshall, Michigan

R. Peglow

Breeder of FANCY GOLDFISH

All Kinds of Aquaria and Supplies

557 Woodward Avenue - Brooklyn, N. Y.

"AQUARIA FISH"

A practical work on care and breeding of
fish in the Aquarium, Greenhouse and out-
door Ponds. Finely illustrated. Every one
interested in keeping fish should send for
a copy of this book. Price, \$1.

Four-Horned Snails (Ampullaria Gigas) de-
posit a mass of large coral red eggs out of
the water, the little snails drop into the
water as they hatch. These snails are in-
valuable for destroying Hydra in the aqua-
rium.

Thoroughbred Collie Pups, beautifully
marked.

F. L. TAPPAN

92 S. 7th Street, Minneapolis, Minn.

Cheaper Than Ever!

(While they last.)

TROPICAL FISH.

Acanthophaelus reticulatus, each	\$.25
Xiphophorus strigatus, each	50c. and .25
Platyoeclia rubra, each	35c. and .25
Danio rerio, each	.50c. and .35
Paradise Fish, each	75c. and .50

Sagittaria plants, each	.05
Real Italian Vallisneria Plants	.10
Very rare Flowering Cayptocoryne, Griffithsi and C. Willisia, each	1.00
Water Ferns, each	.05
Salvinia bogotensis, portion	.10
Brind's "Best-Yet" fish food, 2 for	.25

DOMESTICATED FISH—An exhaustive
illustrated work on Tropical Fish and Gold
Fish. Price, \$2.08, or with supplement
(payable in advance), \$2.60. Supplement
alone will cost \$1.00 after publication.

W. L. BRIND, F. Z. S.,

449 W. 206th St.,
New York City.

Phone before calling! St. Nicholas 8418.

The Pearl Products Co.

Collectors, Acclimators and Breeders of

THINGS AQUAT C

For Aquarium and Scientific Purposes.

Snails	Spotted Water Newts
Tadpoles	Dried Flies
Wild Fish	Fresh Water Mussels
Miniature Rafts	Frogs
Fish Foods	Live Angle Worms
Variegated Rocks	Ants' Eggs
Turtles	Gravel and Sand
Water Insects	Large and Small Pebbles

NOW BOOKING ORDERS FOR SEASON
OF 1917.

Write for Price List.

236 Park Street, Benton Harbor, Mich.

Nice Broad-tails

IN ALL COLORS.

If you want something good, write me.

All correspondence answered.

Chas. J. Hannig

1225 NORTH RANDOLPH STREET,
PHILADELPHIA.

RED - BELLIED DACE

\$20 per 100, or 25c Each

We make a specialty of Jap Fringetails and Telescopes.

Fringetails, 35c., 50c., 75c., \$1.25 and \$1.50 each. Black Telescopes, 75c., \$1.00, \$1.25, \$1.50 and \$2 each. Japanese Snails, 25c., and 35c. each. Evans' Fish Food, best on market, 75c. dozen. One box, 12 cents, postpaid. Cash must accompany all orders. We sell wholesale and retail.

Milwaukee Tripod & Aquarium Company

457 Eleventh street, Milwaukee, Wis

Winners

My Broad-tail Telescope Goldfish were awarded firsts and three special prizes at the last annual exhibition of the Aquarium Society held in the American Museum of Natural History, New York. Young stock from these fine fish for sale during the coming season. Watch my future ads.

Otto Gneiding's Goldfish Hatchery

31-37 Depot Ave., Ridgefield Park, N. J.

FRANKLIN BARRETT

EVERYTHING COMPLETE FOR THE
AQUARIUM, POND AND LAKE

Wyoming Avenue, & C Street, Phila., Pa.

SEND FOR PRICE LISTS

THE TERMINAL PET SHOP

PETS OF EVERY DESCRIPTION AND KIND

Manufacturing and Maintenance of Aquariums a Specialty

All Kinds of Cat and Dog Foods and Medicines

HUDSON TERMINAL BUILDING

Concourse, New York

ONCE YOU TRY, YOU ALWAYS BUY

Gnadt's Perfect Fish Food, 10c box

Pulverized or Whole Shrimp, 75c. lb

BREEDER OF FANCY GOLD AND TROPICAL FISHES

Manufacturer of all kinds of aquariums

Fish nets made of finest netting, 15c.

Great reduction by dozen or gross.

BROADWAY BIRD STORE

P. F. GNADT, Proprietor

1632 Broadway Greenhouse, 1630 Broadway

BROOKLYN, N. Y.

Otto Walter

86 Suydam Street :: Brooklyn, N. Y.

Near Evergreen Avenue L Station

Breeder and Importer of

TROPICAL & GOLDFISHES

Telescopes Calicos Japs Fan-tails

Dealer in All Varieties of Aquatic Plants

All Kinds of Fish Foods

Fresh and Dried Daphnia

AQUARIA, UTENSILS AND SUPPLIES

Thomas Ayling

Fine Broad-tail Telescopes

Some Nice Young and

Breeders at Reasonable

Prices

845 E. Ontario Street, Philadelphia

PLANTS AND SNAILS

HAR-MI Imported Dried Japanese Freshwater Shrimp

The kind you can safely give your fishes. Guaranteed all shrimp—not adulterated. Twenty cents per oz., \$1 per lb., postpaid.

P. J. MUELLER, Importer

2817 Meramec Street :: St. Louis, Mo.

Member, St. Louis and National Aquarium Societies

LORQUINA—The Naturalist's Monthly of the Southwest

Is published monthly by the Lorquin Natural History Club, and contains original observations of naturalists, particularly of the West. Associate Membership, including subscription, \$1.50 a year.

LORQUIN NATURAL HISTORY CLUB.

1051 West 23 Street, Los Angeles, Cal.

IF YOU

Are Looking for Something Extra

Fine in Broad-tail Telescopes

Don't Forget **W. H. HEIMBACH**

Breeder and Importer of FINE FISH

Snails Plants

FISH FOR SALE AT ALL TIMES!

413 NORTH TENTH STREET

ALLENTOWN, PA.

To Keep Your Fish Well Use Regenia Aquarium Salts

To replace the natural salts in your aquarium as absorbed by the fishes and snails. Excellent for plants. Help the snails form shell. Benefits the fish. **Box of Six Powders, 25c.** For sale at Pet Stock stores or address Regenia Chemical Co.

To Make Your Fish Well Use Violet-Ray Fish Remedy

Relieves Constipation, Fungus, Tail Rot, Congestion. Safe and effective. **Box of Six Powders, 25c.** For sale at Pet Stock Stores, or address

Regenia Chemical Co.
STATION K.
Philadelphia, Pa.



Blowing your own horn is not good policy, but

a little at times stimulates the sale of a good article. While not exactly "blowing" about it, YOGI, in a short time, has become a good seller all over the country. It is used by more breeders than any other food. Why? It gives

results! They order two or three pounds at a time. Give YOGI Fish Food a trial and I think you will become a regular user. Sample by mail, 10 cents.

ROBERT J. SCHAEFFER

1818 Frankford Avenue Philadelphia

EDWARD S. SCHMID

Emporium of Pets

All Kinds of Goldfishes and Aquatic Plants
Water Lilies

712 Twelfth Street, N. W., Washington, D. C.

Taxidermy Send for Catalog

WALTER BELL

Breeder of Broad-tail Telescopes

BLUES BLACKS CALICOS

4324 WYALUSING AVENUE, PHILADELPHIA

Prices Reasonable

AQUARIUM STOCK CO

150 Chambers Street :: New York City

Aquarium Specialists

GOLDFISH, FOODS, PLANTS, SNAILS, ETC.

Combination Natural Fish Food - Sample Can 10c
Imported Shrimp Fish Food - Sample Can 15c
Imported Wafer Fish Food Large Sample Box 10c

Special Prices on Quantity Lots Cash With Order
Catalogue Sent Upon Request

Orders amounting \$2 delivered postpaid.
Mail orders promptly attended to.

AQUARIUMS OF ARTISTIC DESIGNS

For home, conservatory and lawn. Beautiful and durable. Any size made to order.

FISHES PLANTS ALL SUPPLIES

We go anywhere to construct aquatic gardens
Write for illustrated price list.

PIONEER AQUARIUM CO., Racine, Wisconsin

DRIED SHRIMP

The General Utility Food for Fishes.
Per pound, coarse, 75c.; fine ground, \$1.
St. George's Natural Fish Food, \$1.50 lb.
Sample can, 15c Add postage to your zone

CANADIAN BIRD STORE,

2139 West Van Buren Street, Chicago, Ill.

New Aquarium Book

This richly illustrated volume is of highly practical value to every aquarist, no matter what his specialty. Goldfish culture in all its branches; magnificent photographs of prize-winning specimens, etc., etc.

Gives the only comprehensive list of 300 tropical fishes, their breeding habits, required temperature, food and general care in detail.

The book is now in press, and is expected for March delivery. It will be entitled

GOLDFISH VARIETIES AND TROPICAL AQUARIUM FISHES

By Wm. T. Innes

Sent anywhere upon receipt of price, \$3.00,
by the publishers.

INNES & SONS

129 - 135 N. 12th Street

Philadelphia

Broad-tail Telescopes

Black and Calico

Correspondence Solicited

GEORGE WILT, 1519 N. 62nd St
Philadelphia

CARL LAZER

Dealer and Breeder of Tropical Fishes

Aquarium Plants Red Snails

All Kinds of Aquaria and Supplies

Open Evenings Only, or by Appointment

228 East 18th Street New York City, N. Y.

TEN VARIETIES OF BEAUTIFUL AQUARIUM PLANTS

for \$1.00 Postage Postpaid

J. HENRI WAGNER, 1909 North Capitol
Washington, D. C.

“Everything is Fish that comes to the Net of a Naturalist”

Don't paddle in the water with one hand and be blind with both eyes. In other words, “keep your eyes open” for all nature.

OUR MAGAZINE

The Guide to Nature

WILL HELP YOU

It is edited by EDWARD F. BIGELOW, who fishes in the heavens and earth, as well as the waters under the earth.

Single copy, 10c.

Four months' trial, 25c.

One year, \$1.00.

THE AGASSIZ ASSOCIATION

ArcAdiA

Sound Beach

Connecticut

O. M. S. Co.

(Not Inc.)

123 S. Oakley Blvd., Chicago, Illinois

Look for our advertisement in the next number!

We will offer a collection of beautiful and interesting live-bearing tropical fishes:

XIPHOPHORUS HELLERI
PHALLOPTYCHUS JANUARIUS
LEBISTES RETICULATUS
MOLLIENISIA LATIPINNA

Sufficient Vallitneria and Anacharis (to start you right), will be included without charge. Shipments will begin in May or as soon as the weather permits.

We specialize in exotic fishes of selected stock and aquarium-raised plants.

Correspondence a pleasure.

THE BRUCE FISHERIES

Breeder, Importer, Wholesale & Retail Dealer in

All Kinds of Goldfish

Comets a Specialty

ELGIN K. BRUCE, THORNBURG, IA.

ENCHYTRAE

The Secret of Successful Breeding of Tropical Fishes and the Ideal Live Fish Food.

Portion, 50c (cash or money order) with Instructions how to breed them

CHARLES E. JENNE

109 22nd Street West New York, N. J.

HALLER'S

Hartz Mountain Bird Store

Wholesale and Retail Importer and Dealer in

Genuine Hartz Mountain & St. Andreasburg

CANARIES

Gold Fish, Globes, Pigeons, Pet Dogs, Dog

Medicine, Poultry Supplies

Full Line of Best Imported German Bird Seeds Always on Hand

1108 VINE STREET
CINCINNATI, OHIO

Michaelsen Bros

**GOLDFISH
BREEDERS
FLORISTS**

58th and Walnut Streets
110 South 52nd Street
Philadelphia

Aquarium Fishes
All Kinds of Aquatic Plants
Aquaria & Supplies
Wholesale and Retail

HARRY P. PETERS

1210 N. Warnock Street, Philadelphia, Pa

BREEDER AND IMPORTER
Rare and Fancy Fish

Plants of every variety, Snails and
Aquarium Supplies of all kinds at all
times.

MANUFACTURER OF

Green River Fish Food
10c Box

Green River Baby Fish Food
15c Box

A GOOD FISH FOOD is one of the
most essential things necessary to
keep fish in good health. After the
test of years Green River stands out
as the best food on the market. It
keeps the fish in good color by pro-
moting a healthy, robust growth. It
will not sour or cloud the water. Ask
your dealer or send for it today.

Nippon Goldfish Co

1749 Buchanan Street, San Francisco, Cal

Importers : and : Dealers

JAPANESE GOLDFISH

DIRECT FROM BREEDERS IN JAPAN



Awarded Gold and Silver Medals
Panama-Pacific International Exposition
San Francisco, 1915

ALL KINDS OF AQUARIA AND SUPPLIES

Price Lists Furnished to the Trade Only

Breeders

A large assortment of splendid Telescope
and Jap goldfish at reasonable prices.

Shipping Cans, 35 Cents.

HARRY P. PETERS

1210 N. WARNOCK STREET

PHILADELPHIA

HERMAN RABENAU, Aquarist

PERMANENT DISPLAY OF

Aquatic Life & Terraria

must be seen to be appreciated

Visitors Welcome

Plants and Tropical Fish a Specialty

Importations of New Varieties received
regularly

1163 Myrtle Avenue, Brooklyn, N. Y.

Near Broadway.

50,938

April, 1917

10c Copy

Aquatic Life



H. Goodby
M.L. 1916.

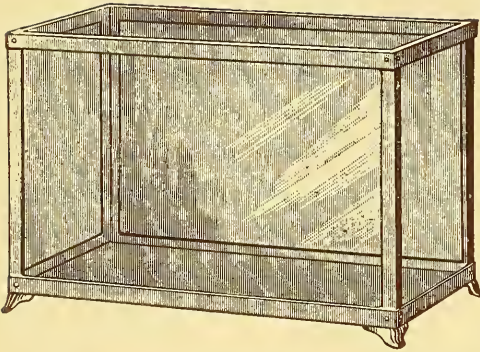

Jacob C. Cassel

915 Arch Street, Philadelphia, Pa

Manufacturer of

AQUARIUMS

Aquarium Ornaments

Floral Terra Cotta, Etc.

Goldfish

Fish Globes

Fish Food

and all aquarium requisites.

Send for Catalog.

Aquarium Specialty Co. 1873 WASHINGTON AVENUE NEW YORK CITY

MANUFACTURERS OF AQUARIA, FOUNTAINS, TERRARIA, VIVARIA

BREEDERS OF DOMESTICATED FISHES

IMPORTERS OF FOREIGN FISHES

AQUATIC PLANTS, SNAILS AND SUPPLIES

STOCK AQUARIA

Galvanized Metal Frame, Enameled and Gold-Striped, Bottom Slate or Ribbed Glass.

No.	Dimensions	Plain	On legs
1.	11"x7"x7"	\$1.25	\$1.50
2.	14"x9"x9"	1.50	2.00
3.	17"x11"x11"	2.25	2.75
4.	20"x13"x13"	3.00	3.75
5.	24"x12"x14"	4.75	5.50

20% additional for oxidizing.

Solid Brass Frame, on Projecting Slate Bottom or on Legs.

No. 1.	12"x 6"x 8" high,	2½ gal.	\$2.50
" 2.	14"x 8"x10"	5 "	3.25
" 3.	16"x10"x12"	9 "	4.75
" 4.	18"x12"x14"	14 "	5.75

20% additional for nickel-plating or oxidizing.

Steel Angle Frame, Heavy Plate Glass, Slate Bottom, Flush or Projecting.

No. 3½.	24"x14"x14",	22 gal.	\$8.00
" 4½.	30"x16"x16",	36 "	12.50
" 5½.	36"x18"x18",	54 "	20.00
" 6½.	42"x20"x20",	80 "	35.00
" 7½.	48"x22"x22",	110 "	60.00
" 8½.	54"x24"x24",	145 "	95.00
" 9½.	60"x26"x26",	180 "	135.00

All our aquaria are so constructed that water cannot come into contact with the metal.

All sizes and shapes made to order. We charge only actual cost for packing and cases.

FISH FOODS

	Per Tin box.	Per lb.
Natural Fish Food....	\$.10	\$.50
Universal Fish Food...	.15	2.00
Ground Dried Shrimp..	.10	1.00

	Per Tin box.	Per lb.
Ground Dried Flies and Insects20	3.00
Ground Dried Daphnia..	.20	\$3.00
Infusoria Creating Food	.15	2.00

Correspondence Solicited. JOSEPH TAUBLES, Manager. No Catalogues

IF YOU

Are Looking for Something Extra
Fine in Broad-tail Telescopes

Don't Forget W. H. HEIMBACH

Breeder and Importer of FINE FISH
Snails Plants

FISH FOR SALE AT ALL TIMES!

413 NORTH TENTH STREET
ALLENTOWN, PA.

OSCAR LEITHOLF

433 Fourth Avenue, Pittsburgh, Pa.

TROPICAL FISHES

PLANTS :: SNAILS

Planorbis corneus Var. rubra

Paludina vivipara

Aquarium: 281 Southern Avenue.

Write for Price List.



The Mexican Swordtails

WALTER LANNOY BRIND, F. Z. S.

WATER COLOR BY A. DESCHERMEIER



Mexican Swordtail

Xiphophorus helleri

Courtesy of the Chicago Aquarium Society

Probably no "tropical fish," as we use the term, is better known to all of us than the Mexican Swordtail, otherwise *Xiphophorus helleri*. Under this name the fish with the markings and coloration of the illustration above was introduced into Germany in the spring of 1909—a single specimen. A little later more were received and bred in large quantities, the price of a pair dropping rapidly from \$12.50 to \$1.50, a price approximately its present value in the United States today. This fish made a bigger "hit" in Germany than any other aquarium fish before or since. Its beautiful colors and the ease with which it could be propagated by the veriest amateur attracted attention at once. During my stay in Berlin in 1910 I secured a pair, paying, if I remember right, about six marks. At that time no other species or variety of swordtail was known in Germany.

Heckel described *Xiphophorus helleri*, but, according to Professor Regan, of the British Museum, to whom the Germans formerly sent all new fishes for identification, the fish introduced was not *X. helleri*, but *X. Guentheri*. The differ-

ence between these two varieties lies in such fine points as the number of scales in the lateral line, rays of the fins, and so on. These distinctions, while necessary to the work of the systematic ichthyologist, need not concern us aquarists; we are more interested in studying the habits of the fishes. The late Seth Eugene Meek, of the Field Museum, Chicago, who had abundant opportunities to study and observe this fish in its native Mexico, considered *helleri* and *guentheri* as merely varieties, and not distinct species as we accept the term. I hold this view—local climatic, geological and water conditions influence to a pronounced degree the coloration, markings and other characteristics of many fishes. The American brook trout taken from a number of streams will differ considerably, but no sane scientist considers the variations sufficient to warrant making new species. The student is already bothered sufficiently with names better left unconfessed. Anyway, the old name of *helleri* will probably stand, having been the first adopted, as far as we aquarists are concerned.

Since 1912 we have received—always from Germany, and never direct from the native country—sundry other varieties or forms of *Xiphophorus*: *X. jalapae*, recognized by the rich orange-red single lateral stripe on the male, and paler yellowish-orange stripe on the female (the single stripe of *helleri* is more a brownish-red); *X. rachovii*, a form from Guatemala with a double red stripe on the sides of both sexes, several narrow blackish vertical

stripes *brevis*, but has a blackish blotch at the base of the tail, as in *rachovii*. Only the male swordtails, with very few exceptions, possess the extension of the lower rays of the tail-fin, from which they derive the common name. So much for the outward markings and colorations of the forms with which we are familiar. The distinctions I have given will serve to identify the ones apt to be met.

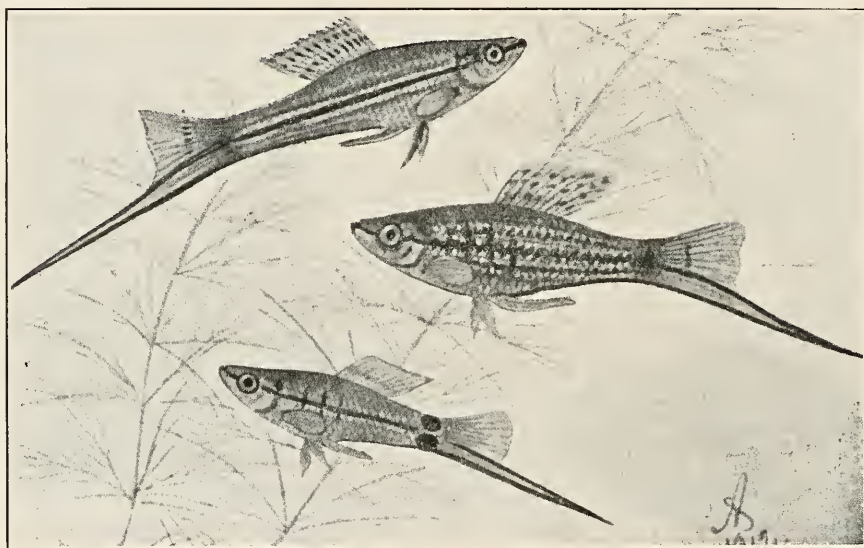

Typical Swordtail (upper) and Two Variants

stripes, and a blackish double spot or "half moon" mark at the base of the tail; *X. strigatus* with a blackish lateral line from the eye to the tail (this form is but little known to aquarists); *X. brevis* suggests hybridization with *Platypocilus*, as it has a number of blackish blotches on the sides, an almost total absence of the lateral stripes so conspicuous in the others, a yellowish "sword" of noticeable shortness in the male fish; *X. montezumae* comes from the basin of the Rio Panuco, Mexico, and resem-

Any of the aforesaid forms can be easily crossed with another, and indeed with the various forms of *Platypocilus*, as has already been done by many of us, so I think that we can rest assured that they are not distinct and valid species. The differences are not specific, and are probably due to environment. Any aquarist can make interesting studies of hybridization in his aquaria, and should report results, with photographs if possible, to the editor of this magazine. All are easily bred and reared in well-planted

aquaria, having a temperature of 75 degrees Fahrenheit. Breeding is extremely easy. It is merely necessary to place the female, when she seems about to drop the young, in a tank full of a dense growth of plants. The species is, of course, live-bearing, and when the young have been expelled the female should be removed at once, otherwise she will promptly devour her offspring. Every aquarist should have a few swordtails in his tanks, if only one or two forms.

Holbrook's Gambusia

G. P. VON HARLEMAN

In the opinion of the writer *Gambusia affinis* var. *holbrooki*, a member of the tooth carp family, is one of the most desirable and interesting of our aquarium fishes. Experienced fanciers have kept and bred the species for years, but all novices are not acquainted with it, and for them this article is written. It inhabits our Southern States, and particularly the fresh waters of Louisiana and Florida.

A full-grown male measures one inch long, rarely will it be one and one-half inches. Average specimens are silvery white, or yellowish white, with regular black spots. Those with the silvery white ground color are preferred, the blackest specimens being held in the highest esteem. All-black ones have been produced by selecting as breeders males on which it was the dominant color. These little jet black fellows, with glistening white eyes, are exceptionally handsome fish.

A casual observer would probably mistake the female of the species for an entirely different fish, so different is she from her mate in color, and so much larger—one and one-half to two and one-fourth inches in length. Her back is gray-brown; sides light olive, with a

metallic lustre; dorsal and caudal fins beautifully rounded and evenly marked with small dark dots; belly is white, with a black spot on the sides. I don't agree with those writers who consider this spot an indication of pregnancy as far as this species is concerned. I have had a female alone in a small tank for several months, and at the end of the period the spot was just as prominent, no young having been expelled.

The Holbrooki is a prolific fish, and will expell a batch of youngsters at intervals of four to six weeks during the

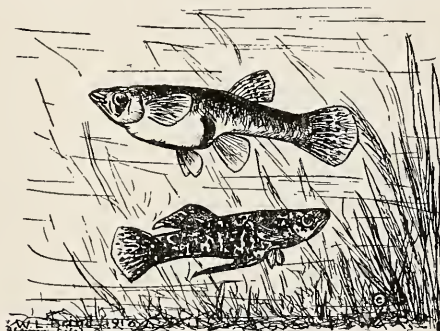

Gambusia affinis holbrooki

From "Domesticated Fish" by W. L. Brind

spring and summer. From ten to thirty will be born at a time, the number depending to a large extent upon the size of the mother. A female once delivered seven, but I have a suspicion that she devoured quite a few before I removed them to another tank. For a successful delivery I advise placing the female when her greatly distended body when viewed from above indicates that she is "ripe," in a tank holding about four gallons, which should be densely planted with *Sagittaria*, *Myriophyllum* and *Nitella*. The tank should have been standing several months and have a good growth of algæ. The dense vegetation, especially *Nitella* and *Myriophyllum*, will serve as an effective shelter for the young. Another good plan is to place the female in a spawning box. In any event the young

must be separated from the parent as soon as possible otherwise they will surely be devoured. Their first food will be the larger infusoria possibly, and I have found that they incessantly nibble the algæ that grows in profusion on the glass. When larger they should get Daphne and Cyclops. Live food, however, I don't believe to be absolutely

sizes, using the coarsest for the large ones and the finest for the babies. I find it extremely satisfactory, and my fishes seem to like it. All get a little of it every day, and scraped lean raw beef every other day.

In concluding my little story of Holbrookii I suggest keeping its aquarium at a moderate temperature, 65 to 70 degrees Fahrenheit, being most acceptable to this hardy and attractive aquarium fish.

The generic name *Gambusia* is derived from the Cuban word "gambusino," which means "nothing;" *affinis* means related; *holbrookii*, in honor of Holbrook.



Nitella flexilis

Courtesy of Innes and Sons

necessary. I have raised three consecutive broods on finely ground dry shrimp, but I think they would have grown faster on live food. In nature Holbrookii feeds on mosquitoes and other insects, at times mosquito wrigglers will be its principal food. It also eats vegetable matter, such as diatoms, desmids and filamentous algæ.

I use quite a good deal of dried shrimp for all my fishes, sifting it into several

I have now in flower for the first time a large plant of *Sagittaria sinensis*, which has been growing in my 50-gallon aquarium for the past three years. This is one of the tanks that has been doing so nicely by reflected light, about which I wrote you some time ago. The water has been maintained at about 60 degrees, Fahrenheit, since last fall. Many have admired the delicate little blossom.

Another item of interest. Aquarists and lovers of the terrarium are often puzzled to find a food for salamanders. Since early fall I have fed a dozen on a ration made from equal parts of Peter's and Walp's fish foods. After they learned to eat it they took it as ravenously as the fishes.—*J. Henri Wagner.*

Several species of European snails have been introduced into this country, apparently as eggs in straw used for packing imported objects. It certainly speaks for the creatures' resistance that an egg caught on a growing stalk should survive the conversion of the plant into straw, the accidents of warehouse and voyage, and finally hatch out on the waste pile.—*Guide to Nature.*

SCURVY IN GOLDFISH

DR. WILLIAM L. PYLE



RED OPAQUE-SCALED TELESCOPE GOLDFISH

The body is long, but the eyes and fins are splendidly developed
Owned by Fred Schaefer

Physicians have long noted that when babies are fed on condensed milk, or any form of dead or sterilized food, many of them develop scurvy. Some of their symptoms are restlessness, stomach trouble, loose bowels, even dysentery and skin hemorrhages (*Petechia*). Finally, if not given some live food, such as orange juice or raw milk, it grows steadily worse, until some intercurrent affection like pneumonia or measles carries it off, because of its previously weakened condition from the scurvy. When a proud mother shows me her exclusively condensed milk-fed baby I can only congratulate her on her good luck, and at the same time remember that the graveyards are full of just that kind—but this arti-

cle is on scurvy of goldfish.

When daphne is plentiful no fancier thinks of losing a fish, because it is a live food and a typical one. You may foul the tank by feeding too much of it, but the fish will not only survive, but thrive. During the months of winter, however, daphne is scarce or unobtainable, and the dried form of it is only on a par with the many prepared foods on the market. They may all be good, but should not be fed to the exclusion of some form of live food.

The common American goldfish is very tenacious of life, and may survive a whole winter in a foul tank and fed on the common rice wafer, but place a gentle moor or a dainty blue telescope in

the same tank, and in ten days it is dead. Let us analyze its symptoms before it leaves us: restless swimming about the aquarium; vigorous taking of food only to reject it; bowel trouble; hemorrhagic streaks of blood in tail or the other fins, etc. Is this scurvy? Most decidedly, for the cause and symptoms are too similar to those of the infant to be mistaken. Yet I have never seen it described as such in any book touching upon the diseases of goldfish. The little sufferer now becomes the victim of parasites, other complex symptoms arise which need not be mentioned here, and if not promptly removed to salt water it soon becomes but a memory of its former beauty.

The remedy is prevention, and prevention means the use of some sort of live food during the winter. Ground earthworms have advocates. Some claim success by feeding a live oyster. A few of the little white worms, *Enchytræ*, fed daily, is a typical ration. It is easy to raise them. Other food may not be stopped, but do feed them a few of the white worms daily as a relish. They will give that "something" to your little finny friends which causes them to grow with health and vigor.

The feeding of some live food will not save all the young goldfish, but it will prevent this scurvy which is the cause of the heavy mortality. Moreover, I consider that the breeders of goldfish should instruct their customers in the use of live food and thereby stop this everlasting: "Yes, I have had goldfish, but they all soon died."

The Fiery-Black Minnow

If there is anything in names, then that of *Notropis pyrrhomelas* should attract the aquarist. Thus far it seems to have escaped, at least we find no mention of it in aquarium literature. This minnow comes from the Catawba and Yadkin

basins of North Carolina, and is said to be quite abundant. Dr. Hugh M. Smith, in his "Fishes of North Carolina," describes the coloration as follows: Males, steel blue above, the scales darker-edged, belly abruptly milky white; head, pale reddish; muzzle, upper lip and iris, vermilion; dorsal fin, vermilion anteriorly, a black spot posteriorly, with a milk-white tip; caudal with broad black posterior margin, next to which is a wide vermilion crescent, base of tail, pale; anal and ventral fins with white pigment; females duller.

It would seem from the description that the fiery-black minnow would be a very desirable addition to the growing number of American fishes now used by aquarists. It is comparatively small, hence desirable in that respect, reaching a length of three and one-half inches. Dr. Smith says that "it is probably the most beautiful of the minnows, the brilliant red, black and white making a sharp contrast. The males retain their colors until autumn, and possibly throughout the year." Aquarists who are in a position to secure fishes from the Carolinas would do well to endeavor to obtain this very attractive species.

Daphnia in Lake Mendota

The Daphnias occurred in patches of irregular extent and shape, perhaps 10 by 50 meters, and these patches extended in a long belt parallel to the shore. The surface waters were crowded by the Daphnias, and great numbers of perch were feeding on them. The swarm was watched for more than an hour. The water could be seen disturbed by the perch as far as the eye could reach. * * * On this occasion the number was shown to be 1,170,000 per cubic meter of water in the densest part of the swarm.—*Birge*.

THE SPRING PEEPER

RICHARD DECKERT



The Voice of the Peeper comes from Brook and Pond Margin

Spring in the country, as pictured by most of us, means robins, bluebirds, blackbirds and pussy willows. One little messenger of spring, however, remains a mystery, although heard before the cheerful feathered songsters, and often before the willows show their gleaming silvery catkins.

This is a tiny creature of the tree-toad family, known under the scientific name of *Hyla pickeringii*, and commonly called "Spring Peeper."

Sometimes in icy February, after several days of thawing, followed by a heavy, warm rain, his song is heard. It comes from brook and pond-margin, from meadows inundated by melting ice and snow, and from dark woodland pools. It is the shrill, penetrating note, heard every spring all over the Eastern United States and Southern Canada. The first singers tune up in early afternoon, but the full chorus does not perform

until about sundown.

As we approach the pond, one after another of the "Peeperers" drops out until, when we have reached the water's edge, the song ceases entirely. After a few minutes of quiet waiting, there comes a faint "peep, peep" from across the pond, answered by another one nearer, and so on until the chorus has again assumed its ear-splitting fullness. Try and isolate the nearest one from the rest. As you bend down in search among the grass and debris in the icy water, he ceases his song. Great patience is necessary in order to capture the Peeper. He sings from concealment only, and may be entirely under water among a clump of grass or moss, only his nose and eyes protruding. Upon the slightest disturbance he will slowly draw back and creep way down among the roots. The writer has often captured Peepers by whistling in imitation of their calls, locating one particular voice and,

trusting to luck, plunging his hand into the water and tearing up a handful of debris and mud. After carefully poking this apart, often a little dark brown frog would be found in its midst, yellow undersides uppermost, arms and legs tucked close to his body. Slowly the little musician turned right side up, sitting among grass roots, moss, dead leaves, sticks and mud, too chilled to take advantage of the opportunity to escape. His bright golden eyes seemed to blink in wonder at this



Hyla Pickeringii

Photograph from life by D. Franklin

sudden disturbance. By the time he has made up his mind to jump, he has been transferred to the collecting jar, in future to mystify with his song the visitors to the Reptile House in the Bronx Zoo, New York.

All Peepers captured in the early spring are dark brown, almost black, in color above. Most of the specimens are males, who far outnumber the females. The male has a dark brown or deep yellow throat, which can be distended into a round vocal sac of one-half the size of the Peeper himself, which explains the carrying power of his song. This is tremendous for so small a creature, and on still nights one can hear the Peepers from ponds half a mile and more distant.

The female's throat is white or pale cream color, often spotted with tiny brown specks.

After being in captivity for a few days the Peeper's dress assumes paler hues, some turning yellowish, others reddish brown. In this dress the dark cross on the back and bars on the limbs show up prominently. Although the Peepers begin their singing in February, they are often interrupted by cold spells, sometimes lasting for weeks. The eggs are therefore seldom laid before the first week in April. They are deposited singly, dropping to the bottom of the pond among the fine grass and debris.

Between 600 and 1000 eggs are deposited by one female. The eggs are hatched in from four to fifteen days, depending upon the temperature of the water. The tadpole takes from 90 to 100 days to turn into a baby Peeper. The freshly metamorphosed Peeper is large when the size of the adult is considered. Peepers leave the water before the last vestige of the tail is absorbed, and these curious little tailed froglets can often be seen in midsummer, climbing around on the cat-tails and weeds adjacent to the pond where they spend their infancy. This shows that already their hunt for small spiders, flies, gnats, plant lice and mosquitoes has begun. The adults are seldom seen during the hot summer months, silently hunting among weeds, bushes and tree tops.

Beginning about the last week in August, and continuing throughout autumn, their calls will again be heard in meadows and woodlands. They will now be found on golden rod, purple aster, marshmallow and other flowering weeds, also on low bushes. During early November I have captured many among dead leaves on rising ground near a dried-out pond. They were no doubt

Concluded on Page 107

An Aquarium of Mahogany

JOSEPH F. HEILMAN

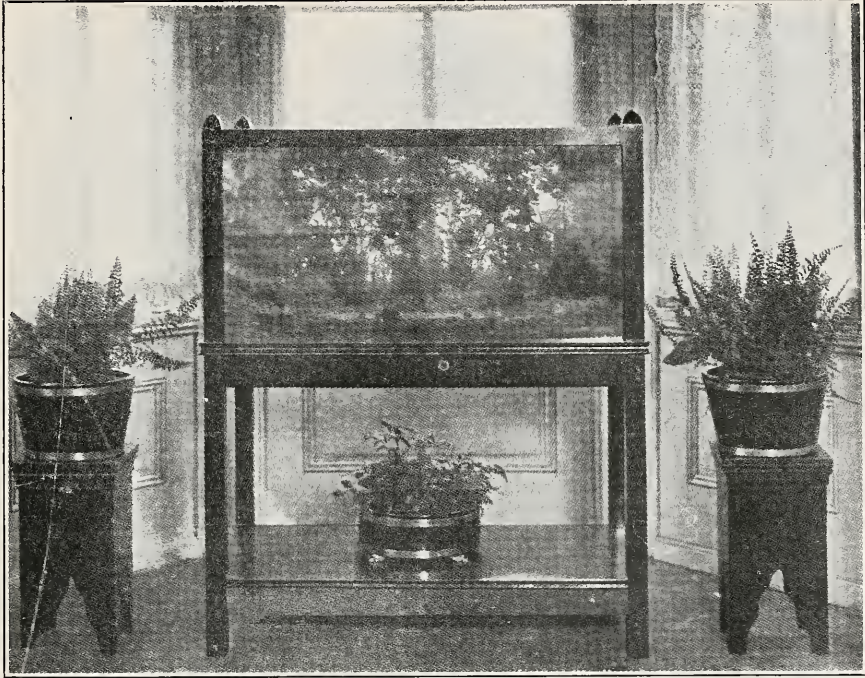

Contrary to the oft-expressed opinion I have found that it is in every way possible to build durable aquaria with frames of wood instead of metal. I have made a number of large capacity—thirty to fifty gallons—and they have withstood the test of years. The wood frame presents a marked advantage over the usual one of metal in that it can be made to conform in style, wood and finish to the furnishings of the room in which it is to be placed.

The aquarium illustrated is made of Cuban mahogany, open cabinet style, and is 48 inches high, 39 inches long and 22 inches wide, outside measurements. The corner posts are two by two inches, and

mortised on the two inner sides to receive the top, middle and bottom rails; top rails 2 by 2 inches to correspond with the posts; middle rails 5 inches wide and $1\frac{1}{4}$ inches thick; bottom rails (shelf support) $2\frac{3}{4}$ inches wide by $\frac{7}{8}$ thick. The rails are tenoned and fit into the mortises cut in the posts, being fastened with French glue and brass screws inserted from the inside. This style of construction makes a very staunch frame with all joints flush on the outer side. The details are well shown in the accompanying drawing, and require but brief explanation. The upper portion of the corner posts, and the top rails, are rabbeted out as shown by figure A, to receive

the glass; B shows the glass in relation to the middle rail, slate bottom and sleeper frame; C the manner of joining the corner posts and rails by mortise and tenon; shelf D rests on the bottom rails, as in E, and is fitted around the posts, but is $\frac{1}{4}$ inch narrower than the supporting rails, being brought flush with the posts by using $\frac{1}{4}$ -inch moulding (M), which is also used around the middle rail, as in B.

The portion of the structure that re-

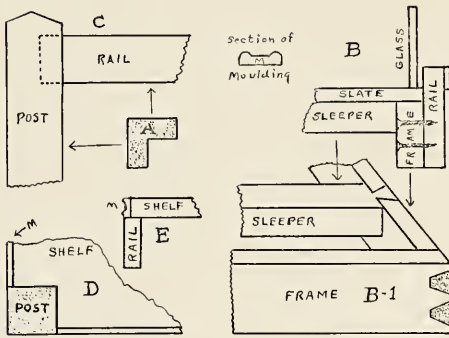

Construction Details

quires the greatest consideration is the frame placed snugly within and fastened to the middle rails, which carries the slate and bears the entire weight of the contents of the tank when filled. Every precaution is necessary to guard against spreading the outer frame. The supporting frame is made of oak, $1\frac{1}{4}$ inches thick and 4 inches wide, the corners dove-tailed into the sides, as at B1. This frame is screwed from all sides into the mahogany middle rail, using No. 14 brass screws $1\frac{3}{4}$ inches long.

On the frame and sleepers I spread a cement of the consistency of soft putty, composed of 10 parts fine white sand, such as is used for a fine grade of sand-paper, 10 parts plaster of paris, 10 parts litharge and 1 part of finely powdered resin, all carefully mixed in boiled linseed oil. The slab of slate, $\frac{1}{2}$ inch thick,

was then firmly pressed in place. Cement mixed according to this formula becomes as hard as a rock, and adheres to both slate and wood. Ordinary aquarium cement was used to set the glass sides.

The lower portion of the structure can be enclosed by paneled doors, and a place afforded in which to store foods and tools incidental to the care of the aquarium. I preferred to leave mine open, and at one time used the shelf for a miniature Japanese garden. I had a pan made of aluminum, slightly smaller than the shelf, three inches deep, with a turned edge. In this was placed a smaller pan, which formed a lake. Rocks of curious shape were suitably arranged, and the crevices filled with leaf mould, the landscape grading down to the lake level. Dwarfed Japanese plants of various kinds, about thirty species of native mosses, and some miniature Jap houses and pagodas completed the picture.

Lay the head of a fish quite open and look for the brain. You will be quite surprised when you see it. It is singularly small in proportion to the size of the fish. I have just opened the head of a Whiting, and find that the brain is not larger in proportion to the volume of the body than a walnut would be to an ordinary-sized man. In the specimen mentioned the brain is scarcely one-third as large as one of the eyes.—*Rev. J. G. Wood.*

Of all inorganic substances, acting in their own proper nature, and without assistance or combination, water is the most wonderful.—*Ruskin.*

Empty seat where Willi: sits, sufficient is the reason; kids can't study when the weather flits toward the fishing season.

On Gasteropelecus

C. J. HEEDE

About two years ago the Aquarium Specialty Company introduced to the aquarists of America two interesting species of *Gasteropelecus*, natives of the Amazon River, of South America. These odd fishes, *G. stellatus* and *G. fasciatus*, have a peculiarly shaped body, very thin and very deep in proportion to the length—one and one-half inches. The pectoral fins are held high and look not a little like wings; dorsal placed near the tail; ventrals unusually small; anal long and



G. stellatus

G. fasciatus

extending from middle of the body to the tail.

The general ground color of the species is silvery below, becoming greenish on the upper portion of the body. In *fasciatus* irregular dark bands run from the lateral line downward and forward. These markings are absent in *stellatus* which has a dark lateral stripe that widens toward the tail. A line follows the contour of the abdomen of *fasciatus*, but is not so distinct in *stellatus*.

These fishes, though seemingly not built for speed, are really quick swimmers, and make attractive aquarium inmates. The preferred foods are Daphne, Enchytrae, worms, scraped beef and rich artificial foods. A temperature not less than 75 degrees Fahrenheit should be maintained.

The Spring Peeper

Concluded from Page 104

wandering up the hill to seek hibernating quarters among stones, fern roots and under the many mossy stumps. The Peeper has many enemies. Larger frogs eat him at the pond, crows, grackles, starlings and ducks hunt him by day, owls, herons and bitterns by night. Garter, Ribbon and Watersnakes also do their best to exterminate this bright little messenger of spring. In spite of this constant persecution, his numbers are legion, and it is to be hoped that they will remain so. Every creature has his place in nature, and this tiny frog is of great value for its aid in keeping the smaller insects within reasonable bounds.

The Chicago Aquarium Society, with characteristic progressiveness, illustrates the monthly lectures with pertinent moving pictures. The "movies" are occasionally interrupted to flash a "Chicago live wireless" message such as:

"Fishes your hobby? Look out for the psychologist."

"I love my wife, but oh! you aquarium."

"Roses are red, violets blue. I'm a C. A. S. fish. What are you?"

"Aquatic Life, the magazine for us! One dollar per year."

Passenger—"Er—how far are we from land, Cap?"

Captain—"About a mile."

Passenger—"A mile! Why, I can't see it."

Captain—"No; the water's too deep."

"I hope you have found 'Aquatic Life' instructive and interesting." Mr. E. T. Nugent, St. Louis, answers, "Yes, sir. Don't let me miss a number."

Aquatic Life

A monthly magazine devoted to the study, care and breeding of native, tropical, gold and fancy fishes, other animals and plants in the household aquarium.

W. A. POYSER Editor
 JOSEPH E. BAUSMAN Publisher
 542 E. Girard Avenue, Philadelphia.

Entered as second-class matter, September 2, 1915, at the Post Office, Philadelphia, Pa., under Act of March 3, 1879.

Yearly Subscription\$1.00
 Foreign Subscriptions 1.35
 Single Copy10 cents

Payments may be made by express money order, draft, post office order or registered letter. Foreign remittances should be by international money order.

Advertising rates made known on application. "Aquatic Life" is the only magazine in America devoted exclusively to aquatic life, and its value as an advertising medium in this field of nature study is unequalled.

Copyright 1917 by Joseph E. Bausman

Vol. II April, 1917 No. 8

A Story With a Warning

F. R. WEBBER

Never discuss tropical fishes with a book agent. The other day one called in my absence. He looked like a college student. His clothes were of the rah-rah type and his hat was decorated with a ribbon the color of a fried egg. We were expecting a friend of mine whom Mrs. W. had never seen. When the book agent asked for me by name, Mrs. W. asked him inside. She gave him an easy chair in the front room. On the table were several tanks of fishes. The agent at once had an idea. Calling in Mrs. W., he began to ply her with questions. He stated that he had once had a round globe, in which he kept a castle, a lot of shells and two Woolworth goldfish. One day they floated to the top and died.

Mrs. W. explained to him the balanced tank, and several other things, to which

he listened with eagerness. Then began a rapid cross-fire of questions. When I returned the nomadic book dealer greeted me like a long-lost brother. He eagerly asked me whether I had any fishes to sell. I told him no. He asked about the price of the Helli, the Guppy, the Platy and the Retic. He told about a fish down in Chicago which bore a name that he thought was something like "Balona-six," and which took delight in shaking the life out of poor minnows. He asked about temperature control, breeding tanks, and requested my opinion as to the value of *Vallisneria spiralis* and *Sagittaria natans* as oxygenators. He even spoke in familiar terms about *Lemna polyrrhiza* and *Riccia fluitans*.

Of course I warmed up to him at once. Who wouldn't in a remote Wisconsin town, where the members of the family of the fish-verrueckt are rare? He soon had me worked up to a friendly pitch, but I don't think I told him the story of a Chicago man who had a jar of rare tropical fishes wrapped in paper, which he left in care of a heavy-jowled friend with a white apron. Next day the Chicago man returned. He found that the heavy-jowled person had kept the mysterious package carefully, as he had promised to do. He had kept it in the ice-box!

When my visitor had me in a friendly mood he suddenly paused, reached under his coat and pulled from an enlarged pocket a sample copy of a new book on modern Biblical criticism, written for the common people, and from the standpoint of the negative critic. He did not make a sale.

Later I learned that every scrap of knowledge had been gained from my wife ten minutes before. The book agent belonged to the class of people who feed crackers to scabby goldfish imprisoned in globes set in the south window, and

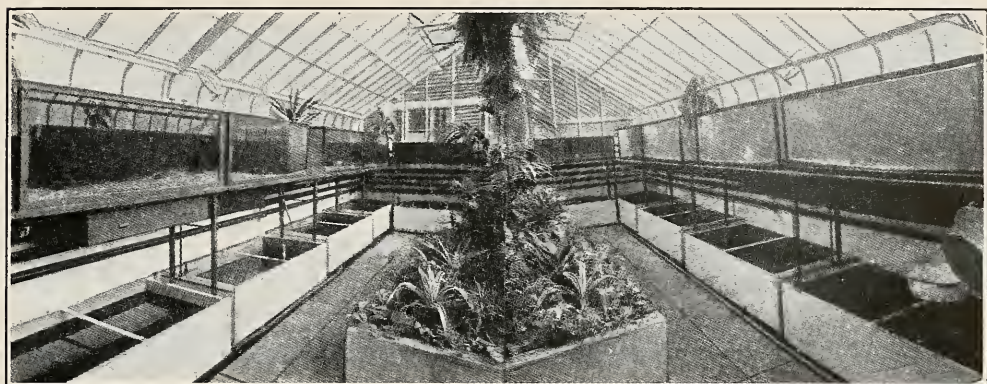

A PANORAMIC VIEW OF MR. PHILLIP'S CONSERVATORY

then wonder what burns holes in their new Serobuck rug, and why the fish miserably perish without warning. Beware of him. He may call on you at any moment. It's dangerous to be safe these days!

“The home of the luckiest fishes” would be a good legend for the photograph of the conservatory of Mr. A. A. Phillips, Jr. It is quite consistent that the finest collection of goldfishes in Brooklyn should disport in the best appointed conservatory in the country. They show their appreciation by being among the winners when Mr. Phillips enters them in a competitive exhibition.

The March meeting of the Philadelphia Goldfish Fanciers' Society was held on the 21st at 802 Girard avenue.

The competition was for Telescope Goldfish, scaled and transparently scaled, bred during 1916. Messrs. Walter G. Beeler, Howard E. Demuth and Claude W. Ramspacher were appointed judges and made the following awards:

SCALELESS TELESCOPES: *Board of Directors silver cup* to George E. Wilt;

blue ribbon, Joseph E. Van Stavern; *red*, Thomas Ayling; *yellow*, George E. Wilt.

SCALED TELESCOPE: *Blue ribbon*, George E. Wilt; *red*, Thomas Ayling; *yellow*, James Fleming.

The annual election of officers will be held at the April meeting, and in accordance with the constitution the candidates were nominated at this meeting as follows: President, Harry P. Peters; vice president, Charles J. Hannig; secretary, Fred Richardson; treasurer, Thomas Ayling; Board of Directors, five to be elected, George B. Smith, George W. Price, George E. Wilt, Dr. F. C. Leffman, Francis X. Garcia, Claude W. Ramspacher, William J. Christy, Joseph E. Tyler, Harry J. Mackrell.

The third annual banquet and dance will be given on Wednesday evening, May 9th, at Mosebach's Casino, Thirteenth and Girard avenue.

The competition at the April meeting, to be held Wednesday evening, the 18th, will be for Jap goldfish, scaled and scaleless, bred in 1916. The Charles J. Hannig cup and six ribbons will be awarded. —Fred Richardson, Secretary.

Aquarium Societies

The Aquarium Society New York	<i>President</i> —RICHARD DORN Upper Montclair, N. J. <i>Vice-President</i> —DR. E. BADE Glenhead, L. I., N. Y. <i>Secretary</i> —HOWLAND WOOD 156th Street and Broadway <i>Assistant Secretary</i> —CLARENCE B. RUCH 615 West 155th Street <i>Treasurer</i> —J. P. LOWELL 146 Grace Street, Jersey City, N. J.
Aquarium Society of Philadelphia	<i>President</i> —H. R. LIPPINCOTT Collingswood, N. J. <i>Vice-President</i> —H. S. FULLERTON 135 West Wyoming Avenue <i>Secretary</i> —WALTER LEE ROSENBERGER P. O. Box 66, Philadelphia <i>Treasurer</i> —R. L. HARDING 6008 Master Street
Philadelphia Goldfish Fanciers	<i>President</i> —HARRY P. PETERS 1210 North Warnock Street <i>Vice-President</i> —CHARLES J. HANNIG 1225 North Randolph Street <i>Secretary</i> —FRED RICHARDSON 3841 North Marshall Street <i>Treasurer</i> —THOMAS AYLING 845 East Ontario Street
Brooklyn Society Incorporated	<i>President</i> —JOSEPH FROELICH 118t. Francis Place <i>Vice-President</i> —GEORGE W. POST 52 Herkimer Street <i>Corresponding Secretary</i> —A. E. SCHIERBAUM 173 Wiemer Street, Elmhurst. <i>Treasurer</i> —C. H. CHAPIN 39 Kenilworth Place
Chicago Aquarium Society Incorporated	<i>President</i> —S. H. LINDAHL 6733 Ridgland Avenue <i>Vice-President</i> —H. W. KEEDY 19 East Cedar Street <i>Secretary</i> —FRED. G. ORSINGER 123 South Oakley Blvd. <i>Treasurer</i> —G. J. BORGSTROM, JR. 1408 North Kedzie Avenue
National Society St. Louis	<i>President</i> —S. CHICHESTER LLOYD 4442 Morganford Road <i>Vice-President</i> —A. H. THURSBY 3005 Osage Street <i>Treasurer</i> —G. H. FOX 5041-A Alabama Avenue <i>Secretary</i> —CHARLES A. KLOEPPER 4412 Natural Bridge Road
Essex County Society Newark, N. J.	<i>President</i> —MAX G. HAMMERSCHLAG 35 Nelson Place <i>Vice-President</i> —G. W. LUDOLF 85 Springfield Avenue <i>Treasurer</i> —DR. WM. BACHMANN 247 Littleton Avenue <i>Secretary</i> —WM. FELDMAN 214 Runyon Street
Platteville Society Wisconsin	<i>President</i> —ALFRED H. KROG 319 Bayley Avenue <i>Secretary</i> —F. R. WEBBER 325 Bayley Avenue <i>Treasurer</i> —FRANK K. BURG 503 West Main Street
Milwaukee Society	<i>President</i> —LIBORIUS SEMMANN 752½ Thirty-eighth Street <i>Vice-President</i> —E. F. KIECKHEFER 99 Seventeenth Street <i>Corresponding Secretary</i> —REV. G. KELLER RUBRECHT 999 Island Avenue <i>Recording Secretary</i> —REV. PAUL ROTH 2602 Prairie Street <i>Treasurer</i> —GEORGE J. C. STEFFENS 950 First Street
Reading Society	<i>President</i> —JOHN KERSHNER 223 South Third Street <i>Vice-President</i> —W. H. HMMERSHITZ 220 Pier Street <i>Secretary and Treasurer</i> —S. O. MELLERT 120 West Windsor Street
Lancaster Society	<i>President</i> —HIRAM PEOPLES New Providence Pa. <i>Vice-President</i> —H. H. MYERS 431 West Orange Street <i>Secretary and Treasurer</i> —W. M. HAWMAN 250 East Ross Street
San Francisco Society	<i>President</i> —F. S. CURTIS 760 Church Street <i>Vice-President</i> —W. J. RICHARDS 449 O'Farrell Street <i>Secretary and Treasurer</i> —HARRY A. KNIGHT 60 California Street
Washington Society	<i>Honorary President</i> —DR. HUGH M. SMITH U. S. Fisheries Bureau <i>Active President</i> —DR. R. W. SHUFELDT 3356 Eighteenth Street, N. W. <i>Vice-President</i> —LOUIS W. BAUER 722 K Street, N. E. <i>Vice-President</i> —MRS. L. HELEN FOWLER Kenilworth, D. C. <i>Secretary</i> —JAMES E. BENEDICT 945 Pennsylvania Avenue <i>Treasurer</i> —EDWARD S. SCHMID 712 Twelfth Street, N. W.
Minneapolis Society	<i>President</i> —F. L. TAPPAN 92 South Seventh Street <i>Treasurer</i> —J. W. FRANZEN Museum, Public Library <i>Secretary</i> —MRS. ANNA ESSENE 3421 South Longfellow Avenue
Pittsburgh Society	<i>President</i> —DR. O. T. CRUICKSHANK 8148 Jenkins' Arcade <i>Vice-President</i> —A. A. ALLEN 221 Belthoover Avenue <i>Treasurer</i> —C. J. MERTEN 24 Chalfont Street <i>Secretary</i> —E. W. HARPER 424 Jaconda Street
Boston Aquarium Society	<i>President</i> —WALTER M. COPELAND Medford, Mass. <i>Vice-President</i> —FRANKLIN A. PACKARD Watertown, Mass. <i>Secretary</i> —WALTER H. CHUTE 110 Chandler Street <i>Treasurer</i> —CHARLES W. ALDEN 15 Broomfield Street

AQUARIUM STOCK CO

150 Chambers Street :: New York City

Aquarium Specialists

GOLDFISH, FOODS, PLANTS, SNAILS, ETC.

Combination Natural Fish Food - Sample Can 10c
Imported Shrimp Fish Food - - Sample Can 15c
Imported Wafer Fish Food Large Sample Box 10c

Special Prices on Quantity Lots Cash With Order

Catalogue Sent Upon Request

Orders amounting \$2 delivered postpaid.

Mail orders promptly attended to.

Nice Broad-tails

IN ALL COLORS.

If you want something good, write me.

All correspondence answered.

Chas. J. Hannig

1225 NORTH RANDOLPH STREET,
PHILADELPHIA.

Cheaper Than Ever!

(While they last.)

TROPICAL FISH.

Acanthopagrus reticulatus, each	\$.25
Xiphophorus strigatus, each	50c. and .25
Platycoecilia rubra, each	35c. and .25
Danio rerio, each	50c. and .35
Paradise Fish, each	75c. and .50

Sagittaria plants, each	.05
Real Italian Vallisneria Plants	.10
Very rare Flowering Cayptocoryne, Griffithsi and C. Willisia, each	1.00
Water Ferns, each	.05
Salvinia bogotensis, portion	.10
Brind's "Best-Yet" fish food, 2 for	.25

DOMESTICATED FISH—An exhaustive illustrated work on Tropical Fish and Gold Fish. Price, \$2.08, or with supplement (payable in advance), \$2.60. Supplement alone will cost \$1.00 after publication.

W. L. BRIND, F. Z. S.,

449 W. 206th St.,

New York City.

Phone before calling! St. Nicholas 8418.

New Aquarium Book

This richly illustrated volume is of highly practical value to every aquarist, no matter what his specialty. Goldfish culture in all its branches; magnificent photographs of prize-winning specimens, etc., etc.

Gives the only comprehensive list of 300 tropical fishes, their breeding habits, required temperature, food and general care in detail.

It will be entitled

GOLDFISH VARIETIES AND TROPICAL AQUARIUM FISHES

By Wm. T. Innes

Sent anywhere upon receipt of price, \$3.00, by the publishers.

INNES & SONS

129 - 135 N. 12th Street

Philadelphia

The Nature Study Review

OFFICIAL JOURNAL
AMERICAN NATURE-STUDY
SOCIETY

The numbers for the coming school year will be filled with special articles from practical teachers dealing with actual works, methods and suggestions for school gardening, elementary agriculture and nature-study.

\$1.00 per year. 15c per copy.

Add for Canadian Postage, 10c. Foreign Postage, 20c. With Aquatic Life One Year, \$1.50.

ITHACA, N. Y.

**BETTER CUTS AT
BETTER PRICES**
PROMPT SERVICE GUARANTEED
GOULD-WILHELM CO. INC.
ARTISTS * ENGRAVERS * PHOTOGRAPHERS
44 N. 4TH STREET PHILA.
SEND FOR SAMPLES AND PRICES THEY WILL INTEREST YOU

"AQUARIA FISH"

A practical work on care and breeding of fish in the Aquarium, Greenhouse and outdoor Ponds. Finely illustrated. Every one interested in keeping fish should send for a copy of this book. Price, \$1.

Four-Horned Snails (*Ampullaria Gigas*) deposit a mass of large coral red eggs out of the water, the little snails drop into the water as they hatch. These snails are invaluable for destroying Hydra in the aquarium.

Thoroughbred Collie Pups, beautifully marked.

F. L. TAPPAN

92 S. 7th Street, Minneapolis, Minn.

TEN VARIETIES OF BEAUTIFUL AQUARIUM PLANTS

for \$1.00 Postage Postpaid

J. HENRI WAGNER, 1909 North Capitol
Washington, D. C.

Thomas Ayling

FINE BROAD-TAIL TELESCOPES

Some Nice Young and Breeders at Reasonable Prices

845 East Ontario Street Philadelphia

CARL LAZER

Dealer and Breeder of Tropical Fishes

Aquarium Plants Red Snails

All Kinds of Aquaria and Supplies

Open Evenings Only, or by Appointment

647 West 184th Street New York City, N. Y.

DRIED SHRIMP

The General Utility Food for Fishes.
Per pound, coarse, 75c.; fine ground, \$1.
St. George's Natural Fish Food, \$1.50 lb.
Sample can, 15c Add postage to your zone

CANADIAN BIRD STORE,

2139 West Van Buren Street, Chicago, Ill.

Otto Walter

86 Suydam Street :: Brooklyn, N. Y.

Near Evergreen Avenue L Station

Breeder and Importer of

TROPICAL & GOLDFISHES

Telescopes Calicos Japs Fan-tails

Dealer in All Varieties of Aquatic Plants

All Kinds of Fish Foods

Fresh and Dried Daphnia

AQUARIA, UTENSILS AND SUPPLIES

HALLER'S

Hartz Mountain Bird Store

Wholesale and Retail Importer and Dealer in

Genuine Hartz Mountain & St. Andreasburg

CANARIES

Gold Fish, Globes, Pigeons, Pet Dogs, Dog

Medicine, Poultry Supplies

Full Line of Best Imported German Bird Seeds Always on Hand

1108 VINE STREET

CINCINNATI, OHIO

THE BRUCE FISHERIES

Breeder, Importer, Wholesale & Retail Dealer in

All Kinds of Goldfish

Comets a Specialty

ELGIN K. BRUCE, THORNBURG, IA.

THE TERMINAL PET SHOP

PETS OF EVERY DESCRIPTION AND KIND

Manufacturing and Maintenance of Aquariums a Specialty

All Kinds of Cat and Dog Foods and Medicines

HUDSON TERMINAL BUILDING

Concourse, New York

FRANKLIN BARRETT

EVERYTHING COMPLETE FOR THE
AQUARIUM, POND AND LAKE

Wyoming Avenue, & C Street, Phila., Pa.

SEND FOR PRICE LISTS

AQUARIUMS OF ARTISTIC DESIGNS

For home, conservatory and lawn. Beautiful and durable. Any size made to order.

FISHES PLANTS ALL SUPPLIES

We go anywhere to construct aquatic gardens. Write for illustrated pricelist.

PIONEER AQUARIUM CO., Racine, Wisconsin

EVERYTHING IS FISH THAT COMES TO THE NET OF A NATURALIST

Don't paddle in the water with one hand and be blind with both eyes. In other words "keep your eyes open" for all nature.

Our Magazine

The Guide to Nature

Will Help You

It is edited by EDWARD F. BIGELOW, who fishes in the heavens and earth, as well as the waters under the earth.

Four months' trial, 25c. One year, \$1.00

THE AGASSIZ ASSOCIATION

ArcAdiA

Sound Beach

Connecticut

O. M. S. Co.

(Not Inc.)

123 S. Oakley Blvd., Chicago, Illinois

Look for our advertisement in the next number!

We will offer a collection of beautiful and interesting live-bearing tropical fishes:

XIPHOPHORUS HELLERI
PHALLOPTYCHUS JANUARIUS
LEBISTES RETICULATUS
MOLLIENSIA LATIPINNA

Sufficient Vallinaria and Anacharis (to start you right), will be included without charge. Shipments will begin in May or as soon as the weather permits.

We specialize in exotic fishes of selected stock and aquarium-raised plants.

Correspondence a pleasure.

GOLDFISH SPAWN

From Choice Telecopes & Japs, \$2 per 100 Eggs

L. N. L. Regular and Baby Fishfood, 10c. Box

W. E. WALP

1309 NORTH 55TH STREET PHILADELPHIA

LORQUINIA—The Naturalist's Monthly of the Southwest Is published monthly by the Lorquin Natural History Club, and contains original observations of naturalists, particularly of the West. Associate Membership, including subscription, \$1.50 a year.

LORQUIN NATURAL HISTORY CLUB,
1051 West 23 Street, Los Angeles, Cal.

ONCE YOU TRY, YOU ALWAYS BUY
Gnadts' Perfect Fish Food, 10c box

Pulverized or Whole Shrimp, 7 c. lb.

BREEDER OF FANCY GOLD AND TROPICAL FISHES

Manufacturer of all kinds of aquariums

Fish nets made of finest netting, 15c.

Great reduction by dozen or gross.

BROADWAY BIRD STORE

P. F. GNADT, Proprietor

1632 Broadway Greenhouse, 1630 Broadway

BROOKLYN, N. Y.

Winners

My Broad-tail Telescope Goldfish were awarded firsts and three special prizes at the last annual exhibition of the Aquarium Society held in the American Museum of Natural History, New York. Young stock from these fine fish for sale during the coming season. Watch my future ads.

Otto Gneiding's Goldfish Hatchery

31-37 Depot Ave., Ridgefield Park, N. J.

WALTER BELL

Breeder of Broad-tail Telescopes

BLUES

BLACKS

CALICOS

4324 WYALUSING AVENUE, PHILADELPHIA

Spawn For Sale Now

GEORGE'S GOLDFISH SHOP

Goldfish of All Varieties

George's Imperial Fish Food : 10c Postpaid

Dried Shrimp : : Box 10c, per pound 60c

Plants Aquaria All Supplies

N. W. 60th and De Lancey Street, Philadelphia

EDWARD S. SCHMID

Emporium of Pets

All Kinds of Goldfishes and Aquatic Plants

Water Lilies

712 Twelfth Street, N. W., Washington, D. C.

Taxidermy

Send for Catalog

Fine Broad-tail Telescopes

BLACK & CALICO

Correspondence Solicited

GEORGE WILT, 1519 N. 62nd Street
PHILADELPHIA

Use Regenia Aquarium Salts

To replace the natural salts in your aquarium as absorbed by the fishes and snails. Excellent for plants. Help the snails form shell. Benefits the fish. Box of Six Powders, 25c. For sale at Pet Stock stores

Violet-Ray Fish Remedy

Relieves Constipation, Fungus, Tail Rot, Congestion. Safe and effective. Box of Six Powders, 25c. For sale at Pet Stock Stores, or address

REGENIA CHEMICAL CO.

Station K.

Philadelphia

Michaelsen Bros

**GOLDFISH
BREEDERS**

FLORISTS

58th and Walnut Streets

110 South 52nd Street

Philadelphia

Aquarium Fishes

All Kinds of Aquatic Plants

Aquaria & Supplies

Wholesale and Retail

Nippon Goldfish Co

1749 Buchanan Street, San Francisco, Cal

Importers : and : Dealers

JAPANESE GOLDFISH

DIRECT FROM BREEDERS IN JAPAN



Awarded Gold and Silver Medals
Panama-Pacific International Exposition
San Francisco, 1915

ALL KINDS OF AQUARIA AND SUPPLIES

Price Lists Furnished to the Trade Only

HARRY P. PETERS

1210 N. Warnock Street, Philadelphia, Pa

BREEDER AND IMPORTER

Rare and Fancy Fish

Plants of every variety, Snails and
Aquarium Supplies of all kinds at all
times.

MANUFACTURER OF

Green River Fish Food

10c Box

Green River Baby Fish Food

15c Box

A GOOD FISH FOOD is one of the
most essential things necessary to
keep fish in good health. After the
test of years Green River stands out
as the best food on the market. It
keeps the fish in good color by pro-
moting a healthy, robust growth. It
will not sour or cloud the water. Ask
your dealer or send for it today.

Breeders

A large assortment of splendid Telescope
and Jap goldfish at reasonable prices.

Shipping Cans, 35 Cents.

HARRY P. PETERS

1210 N. WARNOCK STREET

PHILADELPHIA

HERMAN RABENAU, Aquarist

PERMANENT DISPLAY OF

Aquatic Life & Terraria

must be seen to be appreciated

Visitors Welcome

Plants and Tropical Fish a Specialty

Importations of New Varieties received
regularly

1163 Myrtle Avenue, Brooklyn, N. Y.

Near Broadway.

50,938

May, 1917

10c Copy

Aquatic life

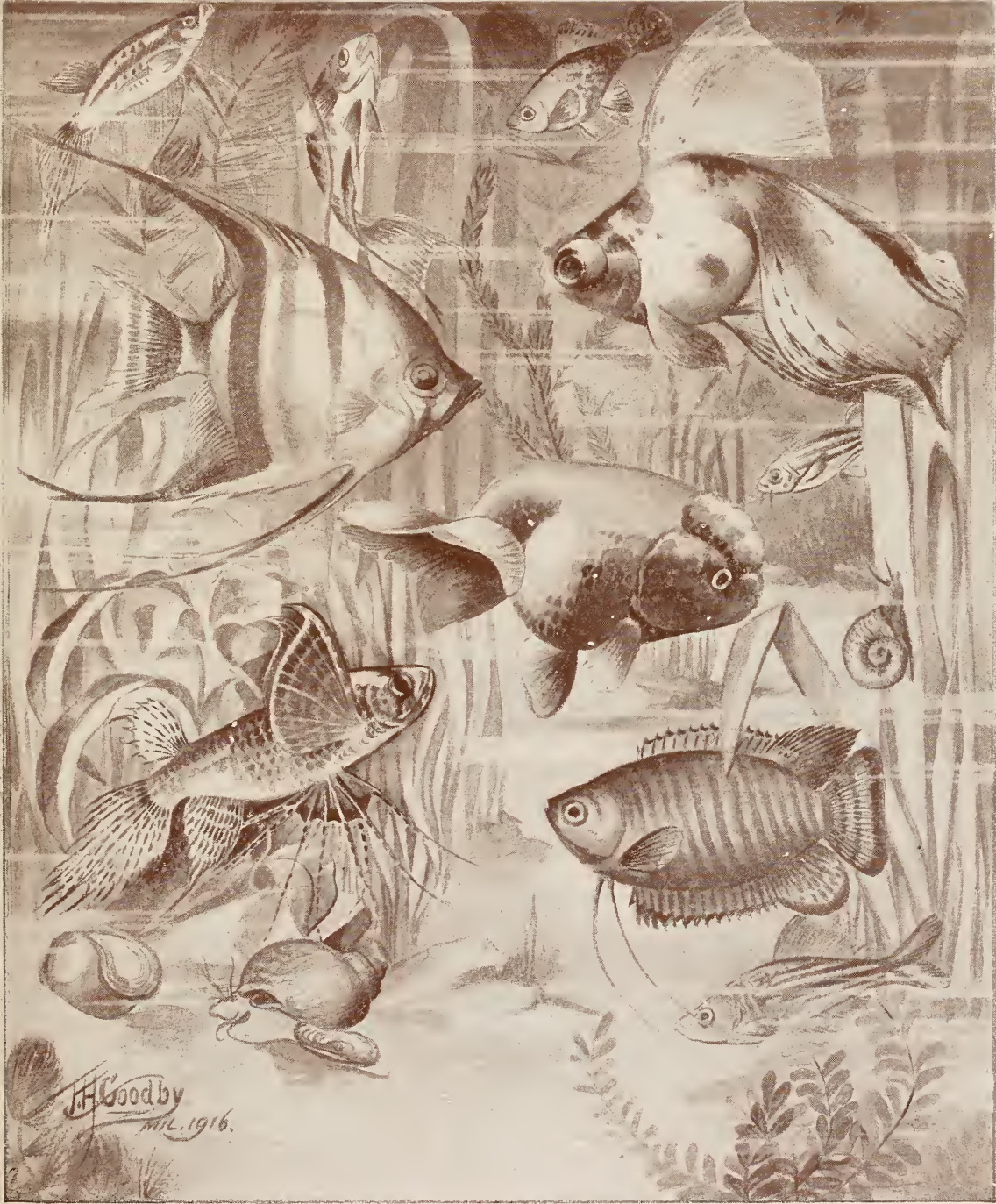

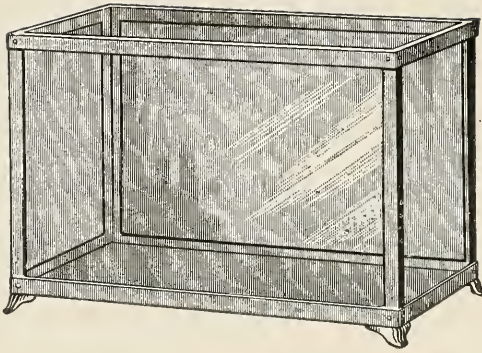

Jacob C. Cassel
915 Arch Street, Philadelphia, Pa

Manufacturer of

AQUARIUMS

Aquarium Ornaments

Floral Terra Cotta, Etc.

Goldfish Fish Globes Fish Food
and all aquarium requisites.
Send for Catalog.

Aquarium Specialty Co. 1873 WASHINGTON AVENUE
NEW YORK CITY

MANUFACTURERS OF AQUARIA, FOUNTAINS, TERRARIA, VIVARIA
BREEDERS OF DOMESTICATED FISHES
IMPORTERS OF FOREIGN FISHES
AQUATIC PLANTS, SNAILS AND SUPPLIES

STOCK AQUARIA

Galvanized Metal Frame, Enameled and Gold-Striped, Bottom Slate or Ribbed Glass. Plain. On legs

No. 1.	11"x7"x7"	\$1.25	\$1.50
" 2.	14"x9"x9"	1.50	2.00
" 3.	17"x11"x11"	...	2.25	2.75
" 4.	20"x13"x13"	...	3.00	3.75
" 5.	24"x13"x14"	...	4.75	5.50

20% additional for oxidizing.

Solid Brass Frame, on Projecting Slate Bottom or on Legs.

No. 1.	12"x 6"x 8" high,	2½ gal.	\$2.50
" 2.	14"x 8"x10"	5 "	3.25
" 3.	16"x10"x12"	9 "	4.75
" 4.	18"x12"x14"	14 "	5.75

20% additional for nickel-plating or oxidizing.

Steel Angle Frame, Heavy Plate Glass, Slate Bottom, Flush or Projecting.

No. 3½.	24"x14"x14",	22 gal..	\$8.00
" 4½.	30"x16"x16",	36 "	12.50
" 5½.	36"x18"x18",	54 "	20.00
" 6½.	42"x20"x20",	80 "	35.00
" 7½.	48"x22"x22",	110 "	60.00
" 8½.	54"x24"x24",	145 "	95.00
" 9½.	60"x26"x26",	180 "	135.00

All our aquaria are so constructed that water cannot come into contact with the metal.

All sizes and shapes made to order. We charge only actual cost for packing and cases.

FISH FOODS

	Per Tin box.	Per lb.
Natural Fish Food.....	\$.10	\$.50
Universal Fish Food...	.15	2.00
Ground Dried Shrimp..	.10	1.00

	Per Tin box.	Per lb.
Ground Dried Flies and Insects20	3.00
Ground Dried Daphnia..	.20	\$3.00
Infusoria Creating Food	.15	2.00

Correspondence Solicited. JOSEPH TAUBLES, Manager. No Catalogues

IF YOU

Are Looking for Something Extra Fine in Broad-tail Telescopes

Don't Forget W. H. HEIMBACH
Breeder and Importer of FINE FISH
Snails Plants

FISH FOR SALE AT ALL TIMES!

413 NORTH TENTH STREET
ALLENTOWN, PA.

MECCO GARAGES
Here is a chance to make money
Write for Proposition
Give References
— ADDRESS —
M. E. Corrugating Co.
COVINGTON, KENTUCKY



The BUTTERFLY FISH

WALTER LANNOY BRIND, F. Z. S.

The butterfly fish, *Pantodon buchholzi*, is not as well known as most aquarium fishes to aquarists, because it has not yet been bred in captivity. Back in 1914 I had one spawn, but the eggs all turned white, presumably because not fertilized.

This odd fish is the only true freshwater "flying fish," though its flights consist more of leaps—volplaning, to use a term of the aviator—of twenty or more feet above the surface of Lake Tchad in West Africa, in pursuit of flying insects upon which it feeds. It also occurs elsewhere throughout equatorial West Africa—Niger, Congo, Gaboon, Cameroon and probably other sections. At the present time I am the fortunate possessor of a fine pair, the female of which is the largest and came to me from a friend who had kept her in solitary confinement in a small aquarium for about a year. The male was one of five owned by the New York Aquarium, and I was lucky enough to secure him in an exchange deal.

My pair do not "scrap," as have most other specimens I have had. On the contrary, they preserve an attitude of "watchful waiting" for any juicy meal-worms, flies or cockroaches which I may pass to them, and as long as the female gets first pick all goes well. They will not eat, and apparently cannot see, any live food unless it floats on the surface, and then it must move to interest them. The prey being acceptable, the fish glides under the surface by means of a gentle movement of its tail, causes not a ripple that might warn an insect of

danger, seizes it, and with two or three gulps, swallows it whole.

I breed meal-worms for my butterfly fish, and, as is well known, they have biting jaws which might cause discomfort to the insides of a fish if swallowed

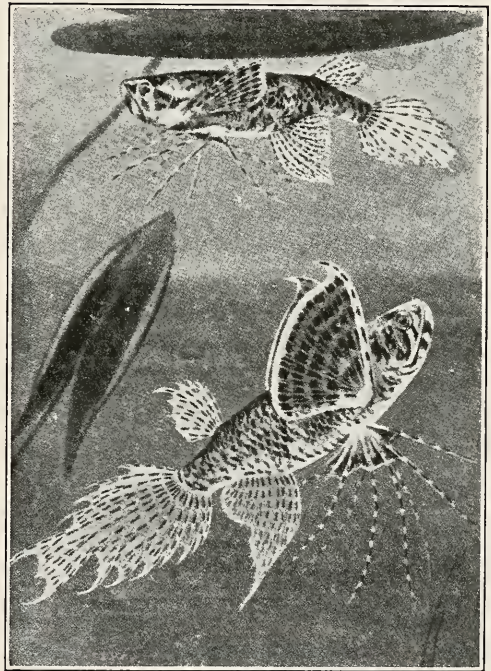

Pantodon buchholzi

whole. The fish seem to know all about this. When a worm is seized, if it be a large and husky one, it is held submerged until drowned, and then swallowed. Again it may take the worm tail first, crunching the head as it passes between the powerful jaws. The end of the lower jaw is hooked and fits into a corresponding notch in the upper one, affording a vice-like grip.

In color the species is like an owl—

brown, black and white, with large silvery scales on the sides. The pectoral or breast fins are shaped somewhat like the wings of a butterfly, which gives the fish its common name. The ventral fins have five extended rays, which, I have observed, are used to crawl through thick, floating or surface vegetation after prey without disturbing the surface of the water or attracting attention. The central rays of the caudal or tail fin are also considerably prolonged, contributing much to the graceful appearance of the fish. The anal fin, which is the feature by which the sexes can be distinguished, is single on the female and double on the male, consisting of a few short rays in front, immediately behind which is a semi-circular soft-rayed shorter portion. I have also observed another distinction not as yet, to the best of my knowledge, referred to elsewhere. All the males I have ever seen, and I have carefully examined the five at the New York Aquarium at one time, have an intermittent organ protruding sideways on the right-hand side, and immediately above and beside the first ray of the anal fin. This organ is formed like a curved tube, about one-eighth of an inch in length. When spawning I saw the male consistently keeping on the left side of the female, both swimming actively at the top, the eggs floating on the surface, white in color and about the size of the head of an ordinary pin. The spawning took place at midnight, so I am inclined to consider the species nocturnal. It seems to prefer water as warm as 99 degrees Fahrenheit, but can stand 65 degrees.

One may wonder how the scales grow in exact proportion to the size of the fish. If he will examine one of them with a magnifying glass he will see that they increase by adding new matter at

the edges; so that each scale increases exactly in proportion to the growth of its owner. The numerous concentric lines on the scales mark the growths of successive seasons, just like the rings in timber.

There is one point in the scales to which particular attention should be directed. If you lay the fish on its side, you will see that there is a conspicuous narrow line which runs from the gill-covers to the tail, and which, in the perch, nearly follows the arch of the back. This is called the "lateral line," and its shape is of great use in distinguishing one fish from another. It is formed in a rather curious manner. Each scale of this line is pierced near its base with a little hole, which corresponds to an aperture in the body of the fish. Through this aperture is poured that slimy substance with which the scales of the fish are covered, and which serves as a defence against the water.—*Rev. J. G. Wood.*

Among the pests apt to despoil the ponds of the fish culturist, especially if large and located in the suburbs or open country, is the Kingfisher, a bird of great beauty. Seldom is the breeder of fancy goldfish bothered, but last year this bird managed to catch a number of goldfish, valued at \$75, from the ponds of the Rev. J. H. Houghton, of Denver, Colo.

The *Inland Printer* gives the following definition of competitor: "A rascal and a sneak. Not very much is really known about him. Said to have horns and a tail. Generally perniciously active between the hours of 8 A. M. and 8 A. M."

CORRECTION. On page 100, April number, for *Nitella flexilis* read *Nitella gracilis*.



The MARBLED SALAMANDER

DR. R. W. SHUFELDT, C. M. Z. S.



This very beautiful species of our salamanders I have had alive but once. Last summer (1916) one came into my possession from a boy who, apparently, had collected it somewhere in the District of Columbia. It was a male in magnificent condition, with the peculiar markings and color very pronounced. As we know, this is the Marbled Salamander

of our batrachian fauna, and in science it has long been called *Amblystoma opacum*, the name having been bestowed upon it by Gravenhorst. It is a somewhat thickset, clumsy species, well shown in the two reproductions of my photographs illustrating the present article. They are natural size, from life, and show the markings well.

The ground color is a dull, slaty black, being shiny only when the animal is wet. It is elegantly marked with various curious designs in pale, grayish-white, the forms of which, and their distribution, are well shown in my pictures. Of these, the upper illustration gives the specimen as seen directly from above, while the one below presents a good side view. I am told that the markings of the Marbled Salamander are inclined to vary considerably, when we come to compare a good series of specimens selected to demonstrate this feature. On its under side the skin is lighter in color, being rather of a bluish black than slaty. Big examples of this species may attain a length of nearly five inches, of which two inches belong to the tail; this latter is stout, and rounded at the base, being more flattened transversely, as we proceed toward its distal extremity.

As to its range, it is found over the central and eastern parts of North America, but it is not common in any locality. This is the only specimen ever examined by me in life; and I am sure the many readers of *AQUATIC LIFE* will be glad to note what the Marbled Salamander looks like. It will eat bits of raw meat and common earth worms; but, unless kept in a very large aquarium, with a good area of terra firma exposed for it to live upon, it is likely to get into deep water; and, as it is a poor swimmer, it will surely come to grief and promptly drown. For the vivarium, however, it is a splendid pet, and a very striking one thus kept with other salamanders.

Mr. Ditmars says of this species: "The larvæ of the Marbled salamander may be found in shallow ponds in the openings of woods. They grow rapidly, and leave the water late in June or early in July. While developing,

they present a dull, grayish appearance, thickly dotted with white, which latter gives way to the markings of the adult a short time prior to their leaving the water. In the adult form this salamander selects dry situations, and may be found under stone in sandy, or dry and hilly country, where it burrows to some depth." It is, in its adult form, not likely to be mistaken for any other species, as it never has any *yellow* markings upon it, like the Spotted Salamander or the Tiger Salamander.

Messrs. Orsinger and Keedy, the O. K. twins of the Chicago Aquarium Society, a short time since made a flying visit to Pittsburgh and (in smaller type) to Philadelphia. We are not just sure what they thought of Philadelphia, because they persisted in talking Pittsburgh until the atmosphere was figuratively and literally "smoky." O. and K. surely put their O. K. on Pittsburgh. We Quakers are just a wee bit jealous! We console ourselves with the thought that at least our fishes like us and get homesick when away. When O. and K. packed up their catch at the home of the editor they incidentally, or rather, accidentally, "copped" a red female Moon-fish that was in a "confinement" tank. On the train between Altoona and Pittsburgh, Mrs. Moon gave birth to a litter, but, becoming homesick, the whole family passed to "the Great Beyond" ere O. and K. arrived at the windy city.

Harry Peters (at the daph pond).—
"Well, George, where are they today?"

George Wilt (slapping vigorously).—
"On the legs and neck mostly."

Yea, 'tis a nature hard to match, a great heart that's sublime, when mosquito bites one can scratch and joke at the same sad time.

The Physics of Respiration

CHARLES M. BREDER, JR.

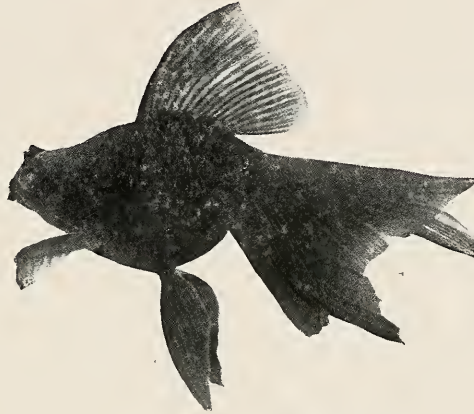

MOOR OR BLACK TELESCOPE BROADTAIL GOLDFISH

Owned by Hartman of Philadelphia

I read with interest the article in the February number on the respiration of fishes, and believe others did likewise. Carrying the idea a step further the following experiment to demonstrate osmosis may appeal because of its simplicity and ease of operation. It shows one of the fundamental facts of life in an accurate and scientific manner.

In order to understand just how the oxygen passes in and the waste gases out through the delicate gill membrane of fishes it is necessary to go to a scientific laboratory for a satisfactory explanation. Under the most powerful microscope yet devised no pores in the membranes are discernible. It is a question to which no real answer has yet been given as to just how the gases penetrate the membrane. However, it is known that this does take place,

and scientists have named the process osmosis.

It can be shown by experiment that if two gases, or liquids, be separated by an animal membrane a transfer of the two will take place through the membrane. It will be found that the transfusion takes place in both directions but the greater flow will be in the direction of the denser of the two. The experiment with the gases is difficult to work outside of a laboratory, but anyone in the quiet of their own kitchen, if the "Madam" is out, may demonstrate this phenomenon with liquids.

A tube is required, an old test tube with the bottom broken off will do. Over the smooth end of it the thin skin found next to the inside of an egg shell must be stretched and sealed around

the edge with paraffin. If a thin sheet of colloidion is available it may be used in place of the egg membrane. This may be obtained by allowing some colloidion to dry on a glass plate and then carefully removing it. It may be sealed to the tube with some of the same material. The tube thus prepared is partly filled with a strong sugar solution, and

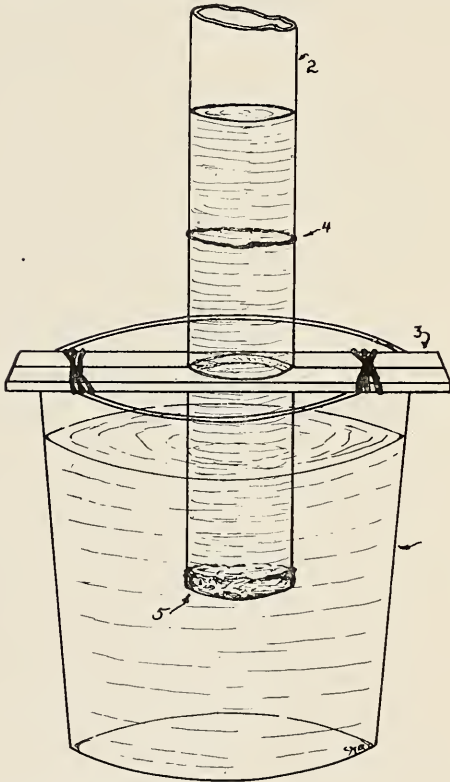

- 1—Glass containing pure water.
- 2—Tube containing sugar solution.
- 3—Strips of wood supporting the tube.
- 4—String marking height of liquid at start of experiment.
- 5—Membranous covering closing end of tube completely.

a string or rubber band passed around it at the level of the fluid. The lower end of the tube is submerged in a glass of plain water. The tube may be suspended by being clamped between two pieces of wood projecting beyond both sides of the glass and held together

with rubber bands. After the apparatus has stood for a few hours, or over night, it will be found that the liquid in the tube has risen some. Just how much may be told by the height of the liquid in relation to the string tied around the tube at the start of the experiment. The extent of the rise will be governed by the strength of the solution, the thickness of the membrane and various other factors. If the water in the glass be measured it will be found that it has lost just as much as the tube has gained. If it is tested for sugar it will be found to contain some, showing that the passage of the fluids was in both directions. If the sugar solution be placed in the glass and the plain water in the tube, the level of the water in the tube will lower, proving that capillarity has nothing to do with it, and the greater flow is always in the direction of the denser medium. All possible effects due to capillarity may be removed by simply using a tube of sufficient diameter. The experiment may be varied by using one colored liquid such as staining the plain water with red ink or some other soluble color.

The recently organized Kensington Goldfish Society, of Philadelphia, gave its first exhibition for Broadtail Telescopes on April 4th. Judges Ayling, Wiggins and Hazlett made following awards:

Opaque-scaled—1st, J. Tyler; 2d and 3d, H. Mackrell.

Transparent-scaled—1st, H. Mackrell; 2d, Wilson; 3d, Harris.

Mr. Mackrell is president of the society; Mr. Garman, vice-president; Mr. Harris, secretary; Mr. Hagensich, financial secretary; Mr. Tyler, treasurer; Mr. Puckall, exhibit manager.

Breeding Labyrinthine Fishes

DEAN LIBORIUS SEMMANN

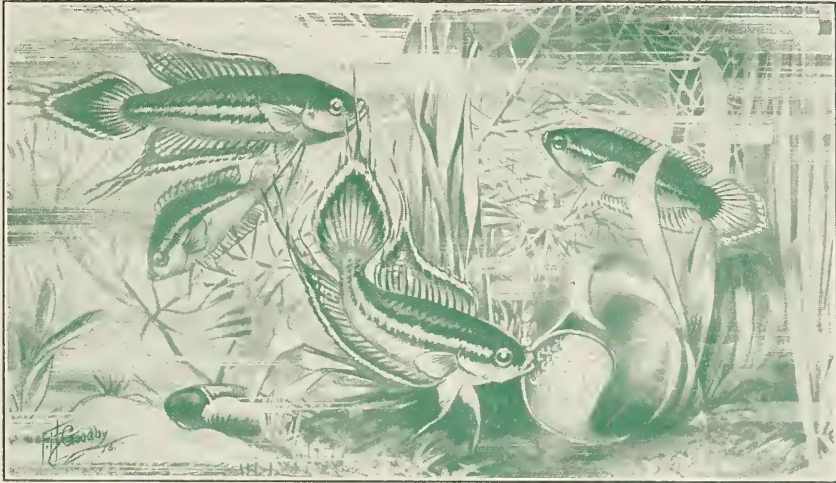

Polyacanthus cupanus Var. Dayi

Original Painting by Francis H. Goodby

Among the most interesting of the many fishes that may be bred in the home aquarium are those of the genera *Macropodus*, *Betta*, *Trichogaster*, *Osphromenus* and *Polyacanthus* of the group LABYRINTHICI—the labyrinth-gilled fishes. More so than with many other fishes it is necessary to understand the conditions that favor the successful rearing of the young. We all know that they build a foamy nest of bubbles; that the eggs are placed in this nest; that they and later the fry are guarded by the male; that the female must be removed immediately after the eggs are expelled, and the male when the fry begin to leave the nest. That is all. More than this is not generally known, and these bare facts are not sufficient to insure successful propagation.

The first essential requirement is a

large tank, as these fishes cannot be bred in a small one. An aquarium not less than 30x15x12 inches should be allowed to stand over winter without fishes and containing a good growth of plants, algae covering a part of the glass, plenty of *Riccia* or other floating plants, and but four inches of water. When spring arrives give the tank plenty of sun, but do not introduce the pair of fish until May or the beginning of June. With abundant sunlight it will develop sufficient *Infusoria* for 300 to 500 baby fish until they are large enough to devour the smallest *Cyclops* and *Daphnia*. The tank can easily be kept in condition by occasionally throwing a little dried and powdered lettuce into it. As soon as the fry are large enough to take small live food, sifted *Daphnia* and *Cyclops* are to be given, later large *Daphnia*,

mashed rain-worm, *Corethra* larva, the inside of meal-worms, scraped meat, and at intervals a little dry fish food of standard brands. *Trichogaster* and *Osphromenus* must also have vegetable foods such as fine algæ and tender leaves of water plants and lettuce.

To breed the labyrinths it is abso-

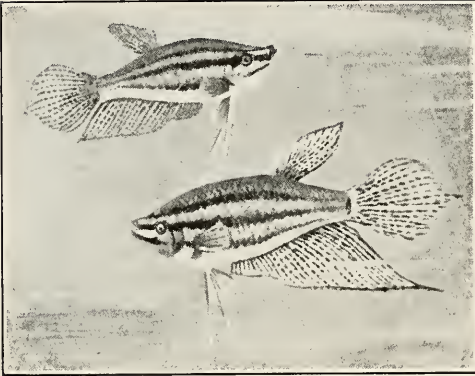

THE PURRING GOURAMI

osphromenus striatus (*Ctenops vittatus*)

lutely necessary to keep them warm, warm, and again warm. The temperature should never fall below 80 degrees, Fahrenheit. Success is impossible of attainment unless they are maintained between 80 and 86 degrees. A sudden change, even though it be only a few degrees, may kill all the young fish. A draft, or cold air, striking the surface of the water, always proves fatal to the eggs and to the fry swimming immediately below; the foam nests are very sensitive to drafts. If the cover of the tank is carelessly raised while a draft passes, or when the air in the room is cool, the bubble nest will dissolve and the fry die. The temperature, when the young begin to swim, should be raised one to one and one-half degrees and kept so for two weeks. Then as the young grow it is gradually lowered, but must never drop below 73 degrees.

The aquarist lacking experience with these fishes usually attempts to breed them in too small a receptacle or in one recently re-set and containing clean, fresh water. Consequently, as the water in the small recently-filled tank is deficient in Infusoria, the young soon starve to death. It is of little use to pour "infusoria water" into such a tank, because to feed all the young so much would be required that the water would be fouled, and more harm than good result. Some writers have asserted that fresh water is better for promoting the propagation of infusorians than old water. This would be true if fresh water contained the foods of Infusoria, but it does not. Whenever fresh water is used to raise Infusoria we find that these fishes do not thrive and gradually die. The water in natural pools contains foods for the

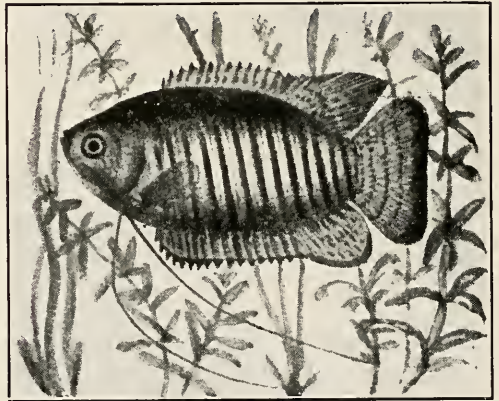

THE DWARF GOURAMI

(*Trichogaster lalius*)

infusorians such as decaying plants and animal excrement of all kinds, so only old water should be used.

I wouldn't miss one issue of *Aquatic Life* for the price of the twelve. I wish it was published twice a month instead of once.—*H. A. Knight.*



BETTA PUGNAX

The Mouth-breeding Labyrinth Fish

C. J. HEEDE

From the Far East, Singapore, to be exact, was brought to the aquarist, in 1905, *Betta pugnax*, one of the many labyrinth fishes. The species is brownish in color with greenish spotted scales; fins with a greenish sheen; dorsal and anal with reddish spots. When mature it measures about three and one-half inches.

This species presents a splendid example of the way in which Nature adapts the habits of her children to their environment. Other labyrinth fishes build a nest of bubbles at the surface of water, in which the eggs are placed to incubate, and in which the young are kept for a few days under the care of a parent. From this method the procedure of *B. pugnax* differs radically. In its native land it inhabits swift running water, in which a bubble nest could not be built; *pugnax* conforms to the conditions by becoming a mouth-breeder.

The initial operation of expelling the eggs and their fertilization is much the same as with the other members of the family. It is in the subsequent procedure that the differing habit becomes evident. The male collects the eggs in his anal fin, which bends at this time, then they are transferred to his mouth by the female. Here they hatch after the manner of the Mouth-breeder, *Haplochromis strigigena*, whose habits and care have already been described by the present writer in a past number of AQUATIC LIFE. The eggs hatch in a few days, and as soon after as possible the parents should be removed, otherwise, as they are very cannibalistic, they would

devour the young.

The food requirements are the same as for the other labyrinth fishes—daphne, enchytræ worms, raw scraped beef and chopped earthworms being preferable. For the newly hatched fry an abundant supply of infusoria is necessary. Later, as they grow, the yolk of a hard boiled egg should be mixed with

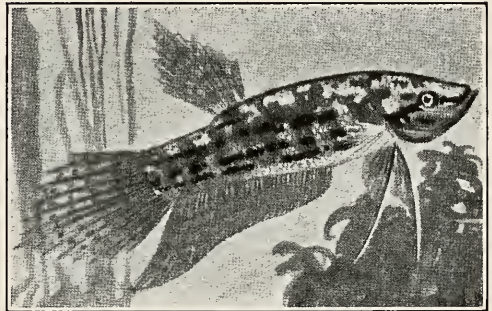

Betta pugnax

a little water, strained through fine fabric, such as thin muslin, and dropped into the tank. When large enough to take them, feed the smallest daphne, then finely scraped beef and, eventually, the same-sized particles as the parents.

Betta pugnax is a splendidly shaped fish, quick in action, and due to its size should be placed in a roomy aquarium. Under ordinary conditions a temperature of 65 degrees, Fahrenheit, will be sufficient, but while breeding and for the young 70 to 75 degrees will be better.

The related *B. splendens* and *B. rubra* are the fishes used for fighting in the East and not *B. pugnax*, which was formerly confused as such, and probably on account of its specific name.

An Aquarium Unique

One of my friends, who lives in one of the densest parts of London, takes his guests into a little back room where, to all appearance, the inmates are partly under water, as if in a diving bell. There is only one window to the room, and that window is apparently the only means of keeping the water out. Through the panes are seen fishes swimming about at

ing crystals, and lighted from above by the blue sky.

How this curious and beautiful effect can be produced is not easily seen until the inventor throws up the window. As he lays his hand on the sash, the spectator is rather startled, because, to all appearance, the glass panes form the barriers against the water. However, the sash glides up easily, and the water does not come in. A closer view betrays



The Mouth Cichlid Breeder *Haplochromis strigigena* Original Water Color by E. S. Young

their ease, sometimes sailing steadily along, and sometimes putting their noses against the window, as if trying to enter the room; aquatic plants are waving their flexible leafage in the water, while many other inhabitants of the river are flitting about as if in their native haunts. In the middle is a fountain, which throws jets of water high into the air, while, as the spectator directs his gaze upwards, he seems to be looking into a nymph's cavern, rich with stalactites, and glitter-

the deception, which is really an ingenious as well as a pretty one. The aquarium is built just outside the window, and is about eighteen inches wider on either side. Both sides and the back are made of brick and slate, well cemented, while the front is of a single sheet of plate glass, which is close behind the window panes, and is not seen when the sash is down. The tank is, of course a very large one, and the back being about

Concluded on Page 122



ON JORDANELLA FLORIDAE

ERNEST LEITHOLF

Last summer, after reading of *Jordanella*, a Florida tooth-carp, and becoming interested in its reported breeding habits, we concluded to add a pair to our collection.

We found it to be an attractive fish, rather shy, but less so during the breeding periods. When half grown it resembles *Platypoecilia* in shape, though the head is more blunt. The full-grown male is decidedly broader. Running along the back of a young male is a faint row of greenish-gray spots on a lighter ground of the same color; a second row extends from the lateral centre to the tail; large bluish-black blotch on side; along back parallel lines of iridescent green alternate with dull greenish-gray changing to coral-red on the sides. The dorsal fin is faintly spotted with reddish-brown; anal with narrow band of coral edged with faint brownish spots; pectorals with suggestion of red; caudal and ventrals colorless.

The female is much duller, having a background of greenish-gray mottled with a darker shade. This mottling is changeable and at times seems to suggest upright bars. In addition to the permanent marking at the lateral centre two or three others show at times. On the sides are broken lines of glistening pale green spots. The fins are colorless, except the dorsal, which has a black spot with a green band at its base.

The pair were placed in an aquarium containing a large bunch of *Nitella*. After several weeks the female became noticeably distended with roe and the

male began to chase her about. Each dash usually ended in the clump of *Nitella*. We awaited developments with interest, expecting the male to live up to his reputation as a guardian of the spawn and fry. We were doomed to disappointment. After several weeks of maneuvering the female became thinner and the pair settled down to ordinary

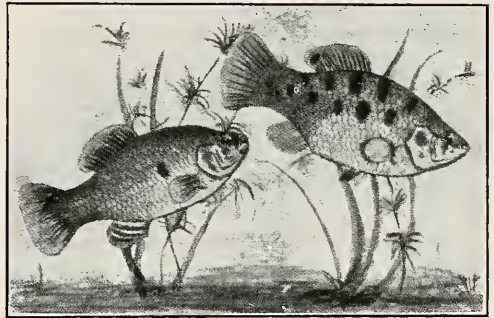

Lower, Male *Jordanella Floridae* Upper, Female

routine. Later attempts were likewise negative. The fish seemed to be gastronomically inclined toward the eggs and not a single youngster appeared. We then decided to change our tactics. After the next spawning operation the *Nitella* was removed and the eggs discovered upon it. They were yellow, adhesive and about the size of those of *Danio rerio*. The plants were then placed in another receptacle to permit the incubation of the eggs without disturbance. Between four and six days later the fry began to appear. Three or four weeks later we had forty youngsters, ten of which reached maturity.

This spring the old pair are confirming our observations of last year, and

Aquatic Life

A monthly magazine devoted to the study, care and breeding of native, tropical, gold and fancy fishes, other animals and plants in the household aquarium.

W. A. POYSER Editor
 JOSEPH E. BAUSMAN Publisher
 542 E. Girard Avenue, Philadelphia.

Entered as second-class matter, September 2, 1915, at the Post Office, Philadelphia, Pa., under Act of March 3, 1879.

Yearly Subscription \$1.00
 Foreign Subscriptions 1.35
 Single Copy 10 cents

Payments may be made by express money order, draft, post office order or registered letter. Foreign remittances should be by international money order.

Advertising rates made known on application.

"Aquatic Life" is the only magazine in America devoted exclusively to aquatic life, and its value as an advertising medium in this field of nature study is unequaled.

Copyright 1917 by Joseph E. Bausman

Vol. II May, 1917 No. 9

have torn several bunches of *Nitella* to shreds. I have arrived at the conclusion that *Jordanella* evinces no interest in the care of the spawn and young unless our pair is an exception. Previous accounts have stated that the male zealously guards the eggs and the resulting fry until they are able to forage alone.

The generic name *Jordanella* was conferred in honor of Jordan; *floridæ*, of Florida.

The Maryland Society

Maryland has fallen into the aquarium with a splash—figuratively speaking. The Aquatic Association of Maryland was organized April 18, 1917, in Baltimore.

The "father" of the association, Mr. W. H. Cassell, was promptly elected president; Ernest A. Gill, vice-president; Louis Hens, treasurer; P. C. Chambliss,

"the littlest one in the bunch," was picked for secretary. Mr. Chambliss does not seem to understand why he was selected, but concludes that it is natural to "pick on the little feller."

A committee, composed of Messrs. Arnold, Marrian and Fishach, was appointed to draft the constitution and by-laws.

The society has been organized to stimulate interest in the animal and plant life of fresh water, especially of the home aquarium, and for mutual education and pleasure. The scientific study of fish culture will be pursued as in the other societies.

A campaign for members is well under way. To be eligible one has only to be interested in aquatic life or have a desire to learn. The bars have been banished and women will be welcome. Applications may be made through any member or to Mr. P. C. Chambliss, secretary, 731 Reservoir street, Baltimore.

The San Francisco Aquarium Society was an exhibitor at the recent Children's Pet Show, held in the Civic Centre Auditorium. A number of splendidly arranged aquaria were shown. Two fully equipped tanks were awarded by the society to the boy and girl entering the best terrarium and aquarium. The fishes attracted great attention and literature on the care of an aquarium was distributed.

Concluded from Page 120

six feet high, and skillfully modeled into the semblance of a rocky cavern flooded with water, and the whole arrangement gives the room a most unique appearance, because the inmates seem to be inhabitants of the cavern, and to be looking through the water at the sky.—
Rev. J. G. Wood.

Philadelphia Goldfish Fanciers

The regular meeting of the Philadelphia Goldfish Fanciers' Society was held on Wednesday evening, April 18, in Saull's Hall, 802 Girard avenue. Annual competition for broadtail Japs. Messrs. William L. Paullin, Thomas Ayling and Dr. J. J. Fralinger, judges, made following awards:

TRANSPARENT-SCALED JAPS.—*Charles J. Hannig Silver Cup* to Dr. F. C. Leffman; *blue ribbon*, Frank Merges; *red ribbon*, George E. Wilt; *yellow ribbon*, Charles Hinkle.

OPAQUE-SCALED JAPS.—*Red ribbon*, Mrs. Elizabeth Ahlers; *yellow ribbon*, Thomas J. Schubert.

Officers for the ensuing year were elected as follows: President, Harry P. Peters; Vice-President, Charles J. Hannig; Secretary, Fred. Richardson; Treasurer, Thomas Ayling; Board of Governors, George B. Smith, George W. Price, George E. Wilt, Francis X. Garcia and Dr. F. C. Leffman.

Messrs. William A. Barber, E. R. Crane and Charles F. Mazdon were elected to membership.

The next meeting will be held on Wednesday evening, May 16th. Competition for Shubunkins and Comets. Six ribbons will be awarded.

FRED RICHARDSON,
Secretary.

“Where ignorance is bliss,” said James Young, the motion picture director, repeating the words after a fellow-member of the Lambs Club, “exactly! Precisely like the Detroit girl who visited the country on May Day.

“She came to a pond whose shallows were full of tadpoles—thousands and thousands of little black fellows flopping about in an inch of mud and water.

“Oh, she said, ‘look at the tadpoles! And to think that some day every one of the horrid wiggling things will be a beautiful butterfly!’”

The most wonderful things in nature are the smallest. A flea leaps 200 times its own length. A six-foot man would have to jump 1200 feet to parallel the event. One species of fly takes 440 steps in traveling three inches and does it in half a second—corresponding to a man running 20 miles a minute.

Statement of the Ownership, Management, Circulation, Etc., Required by the Act of Congress of August 24, 1912, of Aquatic Life, published monthly at Philadelphia, Pennsylvania, for April 1st, 1917.

State of Pennsylvania }
County of Philadelphia } ss:

Before me, a notary public in and for the State and County aforesaid, personally appeared W. A. Poyser, who, having been duly sworn according to law, deposes and says that he is the editor of AQUATIC LIFE, and that the following is, to the best of his knowledge and belief, a true statement of the ownership, management (and if a daily paper, the circulation), etc., of the aforesaid publication for the date shown in the above caption, required by the Act of August 24, 1912, embodied in Section 443, Postal Laws and Regulations, to wit:

That the names and addresses of the publisher, editor, managing editor, and business managers are:

Publisher—Joseph E. Bausman, 542 East Girard Avenue, Philadelphia, Pa.

Editor—W. A. Poyser, 207 South 37th Street, Philadelphia, Pa.

Managing Editor—None.

Business Managers—None.

That the owners are: (Give names and addresses of individual owners, or, if a corporation, give its name and the names and addresses of stockholders owning or holding 1 per cent. or more of the total amount of stock.)

Owners—Joseph E. Bausman, 542 East Girard Avenue, Philadelphia, Pa.; W. A. Poyser, 207 South 37th Street, Philadelphia, Pa.

That the known bondholders, mortgagees, and other security holders owning or holding 1 per cent. or more of the total amount of bonds, mortgages, or other securities are: *None*.

W. A. POYSER, *Editor*.

Sworn to and subscribed before me this 23rd day of March, 1917.

(Seal)

A. D. DEWEES.

(My commission expires February 19, 1921.)

**Do
You**

think Uncle Sam could have built the Panama Canal using a pick and shovel?
think your aquarium can be a success with poor tools?
use a tedious dip-tube or an ancient mud-lever?
use a sloppy siphon and a dozen tin pails?

Are your fish sick? Is your wife sick of your aquarium and you?

WHY? BECAUSE YOUR METHODS ARE OUT-OF-DATE.

Wake up! Spring is here! Find out why my **AQUARIUM WATER PUMP** is the greatest gift to aquarists of the day. Get my Aquarium Water Pump and relegate your playthings to the attic. It will keep your aquarium clean and perfectly aerate the water any day in the year. Send me the depth in inches of the water and the price, \$1.50, in cash or stamps, for postpaid shipment.

WALTER M. COPELAND, 179 Riverside Avenue, Medford, Mass.

Member of the Boston Aquarium Society and the New York Aquarium Society.



“BEST YET” TROPICAL AQUARIUM

(Patent applied for)

**Enables You to Raise Tropical Fishes
Under Tropical Conditions**

Insures real success. Four hundred Danio rerio raised out of 404 eggs, and all from a single spawning.

“BEST YET” FISHFOOD is the Best Yet

(Registered Trade Mark)

Made by BRIND from imported ingredients only. Far excels all dry foods for all fishes, large or small, goldfish or tropical species. Send 25c for two boxes, medium and fine, postpaid.

DOMESTICATED FISH

An exhaustive, richly illustrated work on Tropical Fishes and Goldfish. Price, \$2.08, or with supplement (payable in advance), \$2.60. The supplement alone will cost \$1.00 after publication. Order now and save money!

Forty-six varieties of tropical fishes. Cheap! Fifteen species of water plants, aquarium grown. Enchytra, liberal portion, 25c postpaid. Preserved Daphnia, better than dry, portion, 25c postpaid.

W. L. BRIND, F. Z. S., 449 W. 206th Street, New York

Phone before calling. St. Nicholas 8418.

Always at home Sunday morning.

AQUARIUM STOCK CO

150 Chambers Street :: New York City

Aquarium Specialists

GOLDFISH, FOODS, PLANTS, SNAILS, ETC.

Combination Natural Fish Food - Sample Can 10c
Imported Shrimp Fish Food - - Sample Can 15c
Imported Wafer Fish Food - Large Sample Box 10c

Special Prices on Quantity Lots Cash With Order

Catalogue Sent Upon Request

Orders amounting \$2 delivered postpaid.

Mail orders promptly attended to.

Books for Aquarist

The Home Aquarium and How to Care for It. A guide to its fishes, other animals and plants. By Eugene Smith. 213 pages, 137 illustrations, cloth binding, \$1.20. Add parcel postage on two pounds.

Book of Water Gardening. P. Bisset. Practical information on the selection and cultivation of the plants of the water garden for amateur and professional. 140 illustrations, 200 pages, cloth, \$2.65. Add parcel postage on two pounds.

Address Aquatic Life

(Book Department)

542 East Girard Avenue, Philadelphia

New Aquarium Book

This richly illustrated volume is of highly practical value to every aquarist, no matter what his specialty. Goldfish culture in all its branches; magnificent photographs of prize-winning specimens, etc., etc. Gives the only comprehensive list of 300 tropical fishes, their breeding habits, required temperature, food and general care in detail.

It will be entitled

GOLDFISH VARIETIES AND TROPICAL AQUARIUM FISHES

By *Wm. T. Innes*

Sent anywhere upon receipt of price, \$3.00, by the publishers.

INNES & SONS

129 - 135 N. 12th Street

Philadelphia



KEEP YOUR AQUARIUMS CLEAN With Acton Aquarium Vacuum Cleaners

People are learning that sanitary methods are positively essential to breed good fish. Our cleaners have been a big success amongst the dealers.

Sample by Parcel Post, 50c, 75c, \$1.00

We make an automatic syphon which works as soon as placed in Aquariums.

Mfg. by

Acton Electric Co., Inc.

1133 BROADWAY

NEW YORK

The Nature Study Review

OFFICIAL JOURNAL
AMERICAN NATURE-STUDY
SOCIETY

The numbers for the coming school year will be filled with special articles from practical teachers dealing with actual works, methods and suggestions for school gardening, elementary agriculture and nature-study.

\$1.00 per year. 15c per copy.

Add for Canadian Postage, 10c. Foreign Postage, 20c. With Aquatic Life One Year, \$1.50.

ITHACA, N. Y.

OSCAR LEITHOLF

433 Fourth Avenue,

Pittsburgh, Pa.

TROPICAL FISHES

PLANTS :: SNAILS

Planorbis corneus Var. *rubra*

Paludina vivipara

Aquarium: 281 Southern Avenue.

Write for Price List.

**BETTER CUTS AT
BETTER PRICES**

PROMPT SERVICE GUARANTEED

GOULD-WILHELM CO. INC.

ARTISTS * ENGRAVERS * PHOTOGRAPHERS

44 N. 4TH STREET PHILA.

SEND FOR SAMPLES AT PRICES THEY WILL INTEREST YOU

Walter Bell

Breeder of

Broad-tail Telescopes

BLUES BLACKS CALICOS

4324 Wyalusing Avenue

Philadelphia

Spawn For Sale Now

"AQUARIA FISH"

A practical work on care and breeding of fish in the Aquarium, Greenhouse and outdoor Ponds. Finely illustrated. Every one interested in keeping fish should send for a copy of this book. Price, \$1.

Four-Horned Snails (*Ampullaria Gigas*) deposit a mass of large coral red eggs out of the water, the little snails drop into the water as they hatch. These snails are invaluable for destroying Hydra in the aquarium.

Thoroughbred Collie Pups, beautifully marked.

F. L. TAPPAN

92 S. 7th Street, Minneapolis, Minn.

TEN VARIETIES OF BEAUTIFUL AQUARIUM PLANTS

for \$1.00 Postpaid

J. HENRI WAGNER, 1909 North Capitol
Washington, D. C.

Thomas Ayling

FINE BROAD-TAIL TELESCOPES

Some Nice Young and Breeders at Reasonable Prices

845 East Ontario Street Philadelphia

CARL LAZER

Dealer and Breeder of Tropical Fishes

Aquarium Plants Red Snails

All Kinds of Aquaria and Supplies

Open Evenings Only, or by Appointment

647 West 184th Street New York City, N. Y.

DRIED SHRIMP

The General Utility Food for Fishes.

Per pound, coarse, 75c.; fine ground, \$1.

St. George's Natural Fish Food, \$1.50 lb.

Sample can, 15c Add postage to your zone

CANADIAN BIRD STORE,

2139 West Van Buren Street, Chicago, Ill.

Otto Walter

86 Suydam Street :: Brooklyn, N. Y.

Near Evergreen Avenue L Station

Breeder and Importer of

TROPICAL & GOLDFISHES

Telescopes Calicos Japs Fan-tails

Dealer in All Varieties of Aquatic Plants

All Kinds of Fish Foods

Fresh and Dried Daphnia

AQUARIA, UTENSILS AND SUPPLIES

HALLER'S

Hartz Mountain Bird Store

Wholesale and Retail Importer and Dealer in

Genuine Hartz Mountain & St. Andreasburg

CANARIES

Gold Fish, Globes, Pigeons, Pet Dogs, Dog
Medicine, Poultry Supplies

Full Line of Best Imported German Bird Seeds Always on Hand

1108 VINE STREET

CINCINNATI, OHIO

THE BRUCE FISHERIES

Breeder, Importer, Wholesale & Retail Dealer in

All Kinds of Goldfish

Comets a Specialty

ELGIN K. BRUCE, THORNBURG, IA.

THE TERMINAL PET SHOP

PETS OF EVERY DESCRIPTION AND KIND

Manufacturing and Maintenance of Aquariums a Specialty

All Kinds of Cat and Dog Foods and Medicines

HUDSON TERMINAL BUILDING

Concourse, New York

FRANKLIN BARRETT

EVERYTHING COMPLETE FOR THE
AQUARIUM, POND AND LAKE

Wyoming Avenue, & C Street, Phila., Pa.

SEND FOR PRICE LISTS

AQUARIUMS OF ARTISTIC DESIGNS

For home, conservatory and lawn. Beautiful
and durable. Any size made to order.

FISHES PLANTS ALL SUPPLIES

We go anywhere to construct aquatic gardens.
Write for illustrated pricelist.

PIONEER AQUARIUM CO., Racine, Wisconsin

EVERYTHING IS FISH THAT COMES TO THE NET OF A NATURALIST

Don't paddle in the water with one hand and be blind with both
eyes. In other words "keep your eyes open" for all nature.

Our Magazine

The Guide to Nature

Will Help You

It is edited by EDWARD F. BIGELOW, who fishes in the
heavens and earth, as well as the waters under the earth.

Four months' trial, 25c. One year, \$1.00

THE AGASSIZ ASSOCIATION

ArcAdiA

Sound Beach

Connecticut

O. M. S. Co.

(Not Inc.)

123 S. Oakley Blvd., Chicago, Illinois

Look for our advertisement in the next number!

We will offer a collection of beautiful and interesting live-bearing tropical fishes:

XIPHOPHORUS HELLERI
PHALLOPTYCHUS JANUARIUS
LEBISTES RETICULATUS
MOLLIENISIA LATIPINNA

Sufficient Vallinaria and Anacharis (to start you right), will be included without charge. Shipments will begin in May or as soon as the weather permits.

We specialize in exotic fishes of selected stock and aquarium-raised plants.

Correspondence a pleasure.

GOLDFISH SPAWN

From Choice Telescopes & Japs, \$2 per 100 Eggs

L. X. L. Regular and Baby Fishfood, 10c. Box

W. E. WALP

1309 NORTH 55TH STREET PHILADELPHIA

LORQUINIA—The Naturalist's Monthly of the Southwest is published monthly by the Lorquin Natural History Club, and contains original observations of naturalists, particularly of the West. Associate membership, including subscription, \$1.50 per year.

LORQUIN NATURAL HISTORY CLUB,

1051 West 23rd Street, Los Angeles, Cal.

ONCE YOU TRY, YOU ALWAYS BUY
Gnad's Perfect Fish Food, 10c box

Pulverized or Whole Shrimp, 75c. lb.

BREEDER OF FANCY GOLD AND TROPICAL FISHES

Manufacturer of all kinds of aquariums

Fish nets made of finest netting, 15c.

Great reduction by dozen or gross.

BROADWAY BIRD STORE

P. F. GNADT, Proprietor

1632 Broadway Greenhouse, 1630 Broadway

BROOKLYN, N. Y.

Winners

My Broad-tail Telescope Goldfish were awarded firsts and three special prizes at the last annual exhibition of the Aquarium Society held in the American Museum of Natural History, New York. Young stock from these fine fish for sale during the coming season. Watch my future ads.

Otto Gneiding's Goldfish Hatchery

31—37 Depot Ave., Ridgefield Park, N. J.

BREEDING PAIRS OF

Barbus vittatus Danio rerio

\$1.50 per Pair Add 25c for shipping can

JOHN P. LOWEL

146 Grace Street, Jersey City Hts., N. J.

GEORGE'S GOLDFISH SHOP

Goldfish of All Varieties

George's Imperial Fish Food : 10c Postpaid

Dried Shrimp : : Box 10c, per pound 60c

Plants Aquaria All Supplies

N. W. 60th and De Lancey Street, Philadelphia

EDWARD S. SCHMID

Emporium of Pets

All Kinds of Goldfishes and Aquatic Plants
Water Lilies

712 Twelfth Street, N. W., Washington, D. C.

Taxidermy Send for Catalog

Fine Broad-tail Telescopes

BLACK & CALICO

Correspondence Solicited

GEORGE WILT, 1519 N. 62nd Street

PHILADELPHIA

Use Regenia Aquarium Salts

To replace the natural salts in your aquarium as absorbed by the fishes and snails. Excellent for plants. Help the snails form shell. Benefits the fish. **Box of Six Powders, 25c.** For sale at Pet Stock stores

Violet-Ray Fish Remedy

Relieves Constipation, Fungus, Tail Rot, Congestion. Safe and effective. **Box of Six Powders, 25c.** For sale at Pet Stock Stores, or address

REGENIA CHEMICAL CO.

Station K.

Philadelphia

Michaelsen Bros

**GOLDFISH
BREEDERS**

FLORISTS

58th and Walnut Streets

110 South 52nd Street

Philadelphia

Aquarium Fishes

All Kinds of Aquatic Plants

Aquaria & Supplies

Wholesale and Retail

HARRY P. PETERS

1210 N. Warnock Street, Philadelphia, Pa

BREEDER AND IMPORTER

Rare and Fancy Fish

Plants of every variety, Snails and Aquarium Supplies of all kinds at all times.

MANUFACTURER OF

Green River Fish Food

10c Box

Green River Baby Fish Food

15c Box

A GOOD FISH FOOD is one of the most essential things necessary to keep fish in good health. After the test of years Green River stands out as the best food on the market. It keeps the fish in good color by promoting a healthy, robust growth. It will not sour or cloud the water. Ask your dealer or send for it today.

Nippon Goldfish Co

1749 Buchanan Street, San Francisco, Cal

Importers : and : Dealers

JAPANESE GOLDFISH

DIRECT FROM BREEDERS IN JAPAN



Awarded Gold and Silver Medals
Panama-Pacific International Exposition
San Francisco, 1915

ALL KINDS OF AQUARIA AND SUPPLIES

Price Lists Furnished to the Trade Only

Breeders

A large assortment of splendid Telescope and Jap goldfish at reasonable prices.

Shipping Cans, 35 Cents.

HARRY P. PETERS

1210 N. WARNOCK STREET

PHILADELPHIA

HERMAN RABENAU, Aquarist

PERMANENT DISPLAY OF

Aquatic Life & Terraria

must be seen to be appreciated

Visitors Welcome

Plants and Tropical Fish a Specialty

Importations of New Varieties received regularly

1163 Myrtle Avenue, Brooklyn, N. Y.
Near Broadway.

50,938

June, 1917

10c Copy

Aquatic Life



J.H. Goodby
N.Y. 1916.

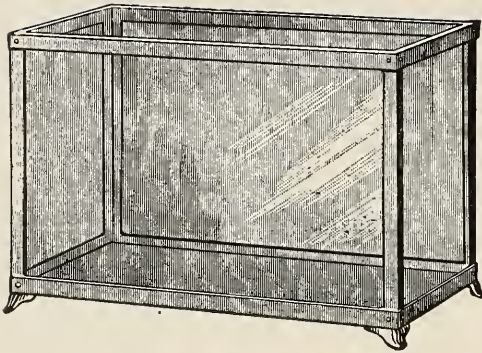

Jacob C. Cassel

915 Arch Street, Philadelphia, Pa

Manufacturer of

AQUARIUMS

Aquarium Ornaments

Floral Terra Cotta, Etc.

Goldfish Fish Globes Fish Food
and all aquarium requisites.
Send for Catalog.

Aquarium Specialty Co. 1873 WASHINGTON AVENUE NEW YORK CITY

MANUFACTURERS OF AQUARIA, FOUNTAINS, TERRARIA, VIVARIA

BREEDERS OF DOMESTICATED FISHES

IMPORTERS OF FOREIGN FISHES

AQUATIC PLANTS, SNAILS AND SUPPLIES

STOCK AQUARIA

Galvanized Metal Frame, Enameled and Gold-Striped, Bottom Slate or Ribbed Glass.

No.	Dimensions	Plain	On legs
1.	11"x7"x7"	\$1.25	\$1.50
2.	14"x9"x9"	1.50	2.00
3.	17"x11"x11"	2.25	2.75
4.	20"x13"x13"	3.00	3.75
5.	24"x12"x14"	4.75	5.50

20% additional for oxidizing.

Solid Brass Frame, on Projecting Slate Bottom or on Legs.

No.	Dimensions	high	2 1/2 gal.
1.	12"x 6"x 8"	8"	\$2.50
2.	14"x 8"x 10"	5"	3.25
3.	16"x 10"x 12"	9"	4.75
4.	18"x 12"x 14"	14"	5.75

20% additional for nickel-plating or oxidizing.

Steel Angle Frame, Heavy Plate Glass, Slate Bottom, Flush or Projecting.

No.	Dimensions	Capacity	Price
3 1/2	24"x14"x14"	22 gal.	\$8.00
4 1/2	30"x16"x16"	36 "	12.50
5 1/2	36"x18"x18"	54 "	20.00
6 1/2	42"x20"x20"	80 "	35.00
7 1/2	48"x22"x22"	110 "	60.00
8 1/2	54"x24"x24"	145 "	95.00
9 1/2	60"x26"x26"	180 "	135.00

All our aquaria are so constructed that water cannot come into contact with the metal.

All sizes and shapes made to order. We charge only actual cost for packing and cases.

FISH FOODS

	Per Tin box.	Per lb.
Natural Fish Food	\$.10	\$.50
Universal Fish Food	.15	2.00
Ground Dried Shrimp	.10	1.00

	Per Tin box.	Per lb.
Ground Dried Flies and Insects	.20	3.00
Ground Dried Daphnia	\$.20	\$3.00
Infusoria Creating Food	.15	2.00

Correspondence Solicited. JOSEPH TAUBLES, Manager. No Catalogues

IF YOU

Are Looking for Something Extra
Fine in Broad-tail Telescopes

Don't Forget W. H. HEIMBACH

Breeder and Importer of FINE FISH
Snails Plants

FISH FOR SALE AT ALL TIMES!

413 NORTH TENTH STREET
ALLENTOWN, PA.

MECCO GARAGES

Here is a chance
to make money

Write for Proposition
Give References

— ADDRESS —
M. E. Corrugating Co.
COVINGTON,
KENTUCKY

On the Inbreeding of Fishes

JOHN LEE BENNINGTON



Blue Calico Telescope Goldfish.

Owned by A. A. Phillips, Jr

Everywhere in nature are evidences of a pronounced antipathy to self-fertilization and inbreeding. While it is true that desirable characteristics can be developed and perpetuated by inbreeding, it is always at the expense of vigor, and degeneration, and even sterility may result. Cross-breeding within the species, in contrast, with the resulting infusion of new blood into any strain, be it fish, bird or beast, means the preservation of strength, vigor, fertility and rate of growth. The mere intercrossing of different lines of species (unrelated individuals), without considering other involved points, will not necessarily work good. The desired result will be dependent upon the selection of individuals embodying the desired characteristics and

stamina.

The plants have developed various means to insure cross fertilization. Many species bear the male and female flowers on separate individuals, or, when a species produces flowers of both sexes on the same plant, or bears hermaphrodite (combination) flowers, the male and female elements do not mature simultaneously; thus fertilization by another plant of the species is necessary. The pollen (male element), is carried from flower to flower by the wind or by insects.

Animals in nature, having the power of locomotion, and free to move about from place to place, mingling with their kind, have not been provided with means to prevent inbreeding. Movement, re-

stricted only by the climatic and food requirements of the species, renders the possibility of consanguinity very slight. When these animals are brought into domestication, with its incidental confinement, it becomes necessary to add new blood from time to time after the second generation has attained maturity.

Goldfish fanciers, working as they are with the very concentrated product of selective inbreeding, should make every effort to outbreed without losing the characteristics they aim to retain in their stock with increased development. With the methods of the average breeder, it is almost an impossibility not to inbreed, this because the young fish are assorted in the rearing tanks according to size, without regard to parentage. Every fancier sooner or later, by fortunate selection of breeding fish, hits upon a combination that produces a number of young of excellent form. With his desire for perfection, when these specimens reach maturity, he will be very apt to mate brother and sister together as it will not be possible to positively determine their relationship. Few breeders have a sufficient number of rearing tanks to keep every lot of spawn distinct from the time of hatching to that when the future breeding fish are segregated, and for this reason line-breeding is impossible. The remedy is the yearly acquisition of a few good specimens from other fanciers.

The subject of inbreeding is equally important to the fancier of the exotic fishes. Such species are usually purchased in pairs, and, if not imported wild stock, are apt to be related. This is particularly liable to pertain if the fish be a rare one or a species seldom bred. A fancier who succeeds with a "shy breeder" has no other course but to dispose of brother and sister as a "pair." It is a wise plan, when buying a species not al-

ready represented in your collection, to secure two pairs from different sources, breaking them and mating the male of one to the female of the other. If the species is not new to the collection, then each male and female should be mated to a home-bred fish. In thus proceeding, nothing will be lost, but much may be gained in vigor, fertility and size, other conditions being favorable.

Alfaro Amazonum

C. J. HEEDE

This live-bearing tooth carp superficially resembles the young of our common shiner, though it attains but a

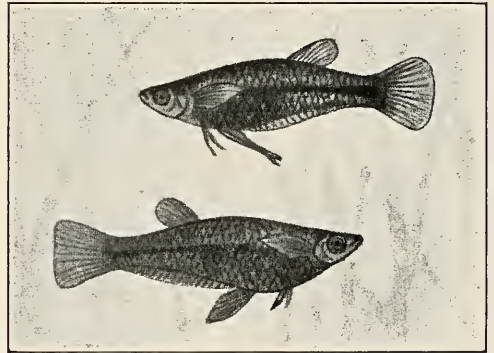

length of about two inches, the female being slightly larger than the male. The body is light bluish-green; upper part of head with some black punctation; black line on side of body from middle to base of caudal fin; fins very light yellow; copulation organ of male golden yellow.

This fish is a rather shy inhabitant of the aquarium, and at the slightest noise or disturbance will hide among the plants. Its remarkable ability to penetrate dense growths quickly, and its voraciousness, make it difficult to save the young. A temperature of 70 to 85 degrees Fahrenheit, should be maintained.

Alfaro is a South American fish from the Amazon river and its tributaries; hence the name *amazonum*. *Alfaro* is based on a local name.



THE GIANT DANIO

WALTER LANNOY BRIND, F. Z. S.

The truly magnificent Giant Danio is a native of the Malabar coast of India—one glance at its gorgeous coloration is sufficient to make one think of its home—the land of the Rajahs. The ground color of the sides is superb metallic turquoise blue; shining emerald green in certain lights. Along the sides are three horizontal golden stripes extending from the tail to a point above the ventral fins, becoming at this place vertical and zigzag bars, and broken blotches of gold. These vertical zigzag markings are more numerous on the female. The centre of the tail of the male is dusky-blackish, with reddish golden stripes above and below the dark central streak; rest of tail and anal, reddish salmon; ventrals similar in color, but lighter; pectorals clear greyish-white; dorsal dusky transparent greyish-white with an indistinct white upper edge divided off by a dusky streak. The female has the dusky central portion of the tail running upwards towards the tip of the upper lobe, and the golden stripes above and below it are not so pronounced. The warm salmon-red diffusion on the tail, other fins and belly of the male during breeding time is hardly apparent on the female, which is more of a pale greyish color on the fins. The females have a deeper abdomen and a higher back, and on this account the golden stripes seem more separated. The line of the back of the female from the head to the dorsal fin is curved, whereas that of the male is almost straight. The sexes of this species are rather hard to distinguish, hence I have gone into considerable detail to point out the characteristics of

each. In point of size the largest I have seen measure four inches over all. I have five of this size at the present writing, all imported specimens.

Danio malabaricus has been bred by aquarists of my acquaintance, but I cannot so far lay claim to that distinction. The main requirements for successful propagation are plentiful sunshine, a large aquarium, high temperature (86 to

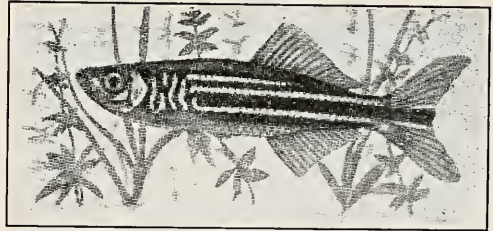

Danio malabaricus (Male)

95 degrees, Fahrenheit), abundant live food and clear, pure water. In a large well-planted aquarium, with the mentioned conditions present, a well-mated and ripe pair of fish, the chances are that a spawning will occur, and if one, then more later under the same conditions. The eggs fall to the bottom and are not adhesive, hatching in a period of twenty-four hours to several days according to the water-temperature. The young attach themselves to the glass sides of the tank or to the plants, hanging from them like coma marks, but soon are able to swim and may be seen darting about near the surface. As soon as the eggs are extruded, or if the operation escapes attention, then as soon as the young are discovered, the parents must be removed to another tank. In the latter case, it may be expected that quite a number

of the eggs will have been devoured by the adults.

The youngsters, after the yolk-sac has been absorbed, must be furnished with abundant Infusoria water—*plenty of it*. After a week or so, as they grow larger, they can be given the finest powdered insect food, followed gradually with tiny screened Daphne and Cyclops. If the temperature is maintained high enough the little fellows can be almost seen to jump in size.

The Giant Danio, *Danio malabaricus*, the largest of the genus known to the aquarist, is undoubtedly the handsomest of all our tropical aquarium fishes.

A Chapter in the Life-History of a Beetle

ERNEST LEITHOLF

Last summer, while collecting in the vicinity of Pittsburgh, I secured two small aquatic beetles, a male and a female, of the family *Hydrophilidae*. I was unable to determine the species. The specimens were elliptical in shape, the back olivaceous brown, and measured about three-eighths of an inch long. While under water, and in the sunshine their abdomens, covered with a thin film of adhering air, sparkled and glistened like silver.

I placed the pair in an aquarium containing a yellow-bellied terrapin, a Cumberland Painted Turtle and a common newt, *Diemyctylus viridescens*, knowing that in this mixed company the new arrivals could at least work no harm. At first the beetles were kept busy dodging the charges of the older inmates, but these soon ceased.

Shortly after I discovered a white needle-like spire which projected about an inch and a quarter above the water and had its origin in a pouch resting in a cluster of *Salvinia* roots. Twenty-four hours later another spire appeared close

by. I was now quite interested and, fortunately, did not have long to wait ere their origin was explained. The builders were the beetles. I discovered them at work on a third spire in the position shown by my sketch. The male, head downward, was partly submerged, while immediately above him the female, also head down, was discharging a continuous and scarcely discernable stream. The fluid, which seemed to be gelatinous in consistency, unerringly found its mark

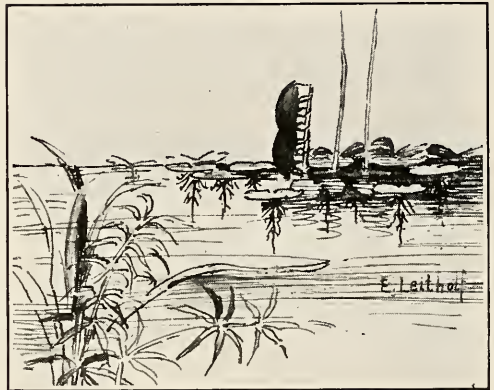

at the summit of the structure and congealed. In an hour the spire was as tall as the others, then both beetles slipped back into the water.

Unfortunately my observations come to a close at this point. The nest was destroyed soon after, and one of the beetles disappeared. In examining the wreck I discovered that the spires were hollow; hence probably served as shafts to supply air to the eggs in the cocoon below the water surface from which they rose.

(The color of the beetle as well as the type of egg-sac would seem to place it in the genus *Helophorus*. The spire is for the purpose of admitting air to the egg mass. The shape of the tube differs in the different genera. This year Mr. Leitholf hopes to again collect this beetle and complete his study of its life-history.—EDITOR).

Notes on the Salamanders

ANNA K. BEWLEY

The salamanders, frogs and toads represent the class of vertebrate animals holding a position between the fishes and the reptiles. Formerly we called them amphibians, which implies that they may be found on land and in water, but now it is customary to refer to them as batrachians.

Twenty or more species of salamanders are found in Pennsylvania, being distinguished by their differing structure, color and mode of living. They are much more numerous than the lizards, since but five species of these reptiles are known to occur in the State.

The Common Newt, *Diemyctilus viridescens*, is probably the most abundant, and is often sold in the pet shops. For such an inconspicuous creature it has the astonishing number of eighteen common names, among them Red Eft, Spotted Triton, Water Newt and Mountain Lizard. Briefly described, this salamander is olive green or reddish above; lemon yellow below; a row of scarlet dots surrounded by black rings along each side; belly with small black spots, skin rough, length of adult, three and one-half inches. It seems to prefer an aquatic existence, but should the pond become dry it will seek temporary shelter under stones or amongst decaying plant remains. Here it awaits the filling of the pond by autumn rains. During its sojourn on land it may become red in color. The eggs are deposited in the water and attached by the gelatinous envelope to submerged plants. The larva is provided with external gills, which are retained until it reaches a length of two inches.

The Red Triton, *Spelerpes ruber*, which may sometimes be confused with the red phase of the common newt, is not so abundant in the vicinity of the



The Spotted Salamander (*Amblystoma punctatum*)

Photograph from life by Dr. R. W. Shufeldt

writer's home. It may be looked for in damp situations, under the bark of fallen trees, beneath stones, or in springs. The most frequent species in this locality is the Gray or Red-backed Salamander, *Plethodon cinereus*. It can be found at

almost any time of the year, under logs and stones in damp places in the woods. The eggs are deposited among moss or under the bark of fallen trees. While this is a strictly terrestrial species, the young are provided with external gills, though they have no use for them. These, however, are absorbed within a few days, and the young are then exactly like the parents.

doctors as the salamander has spots! This creature was also thought to be able to withstand fire. Aristotle mentions this myth on hearsay, but Pliny actually tried the experiment and put a salamander into a fire. He remarks with evident surprise that it was burnt to a powder! Even in our own enlightened country the salamander is thought poisonous by the illiterate. It seems need-



Characteristic Attitudes of the Gray Salamander, *Plethodon cinereus*

Photograph from life by Dr. R. W. Shufeldt

Like their relatives, the frogs and toads, and the fishes and reptiles, the salamanders hibernate during the winter.

In Europe during medieval times the salamanders bore an undeserved sinister reputation. Many strange powers were ascribed to the inoffensive little animals. One of the old writers advises anyone bitten by a salamander to betake himself to the "coffin and winding-sheet," and adds that the victim needs as many

less to add that all our eastern species are entirely harmless. Only one makes any attempt at self defense. The Purple Salamander, says Cope, snaps fiercely but harmlessly and throws its body into contortions in terror.

We are not prepared to credit the Bangor man who says that fishes talk, but we are willing to believe that there are times when they laugh at aquarists.

My Experience With *Cameronensis*

CHARLES H. ROHRBACH

Haplochilus cameronensis. What a big name for such a little fish. It is really amusing to me to show my beauties to friends and pronounce the name for their benefit. They never try to repeat it after me. Friend Wife, however, has invented a nickname, and now my pets are known as the "Happy" family—Daddy Happy, Mamma Happy and the little Happies, and so long as this name distinguishes this family from the others it serves its purpose well.

Among the exotic fishes which have afforded me pleasure to breed, this *Haplochilus* is undoubtedly the most beautiful. The brilliant colors, unusual shapes of fins and supple body must make it a favorite with anyone. Without giving a lengthy description of colors and the formulæ of fins and scales, the features that attract attention are the lyre-shaped tail with stripes of orange, purple, red and blue; the dark blue body spotted with red; the orange-like pectorals, incessantly waving, and the blue eyes always alert to see every movement within and without the aquarium. These brilliant colors and the lyre tail are characteristics of the male. The female, while of the same general shape, has a simple fan-shaped tail and fins of a very ordinary greenish hue.

In its manner of swimming by quick darts with scarcely perceptible fin movement, again stopping still and merely waving the pectorals, or turning with head and body in a graceful curve, *cameronensis* recalls like habits of our other favorite, the Paradise Fish, which, however, is much broader and larger.

The ichthyologist tells us that this spe-

cies is a native of West Africa, in the French Kongo and Kamerun (Cameroun); hence the specific name *cameronensis*, meaning of Cameroon. The species will breed in the aquarium during the late spring and summer, when the water may be maintained at a uniform temperature of about 75 degrees Fahrenheit. The adhesive eggs stick to the plants with which the tank should be abun-

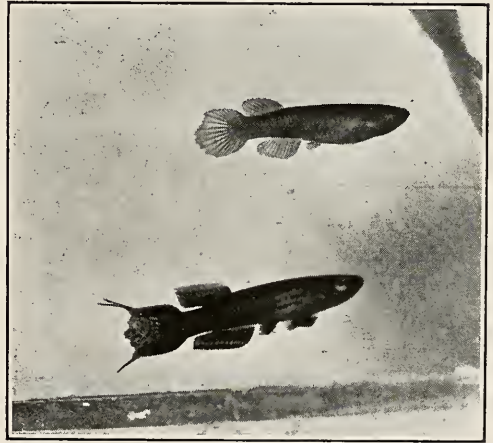

Haplochilus cameronensis

Photograph by Lee S. Crandall

dantly supplied. Period of incubation, ten days to two weeks. They do not seem to be difficult to propagate or my efforts would not have culminated successfully.

My tanks, two of three gallons each, were well planted with *Sagittaria subulata* and *Anacharis*, and placed in a sunny situation so that algæ formed quickly and gave the water a light green tinge, but not sufficient to render them unsightly. From a distance of six or eight feet I have watched them courting, for they are shy in their love-mak-

ing. One would think they had partaken of that first apple, so timid are they when they find themselves under close observation. In courting, the male will dart to and fro caressing the sides of his mate, sometimes facing in the same direction and again head to tail. Nor is the lady unresponsive. Swimming more quietly than is her usual wont, she

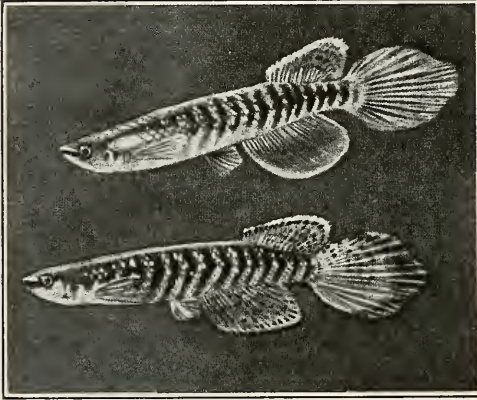

Haplochilus fasciolatus

seemed to enter into the very spirit of the play. This I have observed with great interest. The actual spawning it was not my privilege to see.

During the late spring and summer I changed my pair every fortnight to alternate tanks, hoping by this procedure to save eggs that might be expelled unnoticed. During the first week of August I discovered fry in one of the tanks, and as they were swimming freely they must have hatched several days before. From then on their growth was really quite rapid. During the following week a cup of "green water" was fed daily, then followed tiny Daphne, and by the first of September the little fellows were taking small Enchytræ worms. The eagerness and zest with which the babies enjoyed their meals was indeed a pleasure to behold. Frequently a long worm would be taken by one end while the other vainly twisted and squirmed

about the snout of my prize until finally it disappeared within—to help make one of the little beauties now disporting in my tanks.

Enchytræ is probably the best food. Daphne is, of course, excellent, but unless one is favorably situated to collect it, the simple alternative of keeping a box of Enchytræ is preferable. The Happies will take dry foods composed of ground shrimp, flies, Daphne, etc., but really will not thrive upon them.

On page 123 is shown in natural colors, as accurately as is possible by mechano-photography, a splendid blue calico telescope goldfish from the collection of Mr. A. A. Phillips, Jr. This specimen leaves little to be desired in

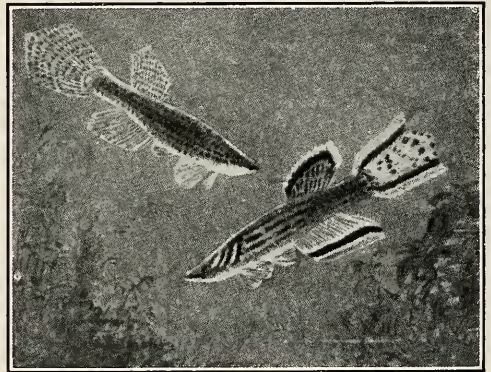

Haplochilus calliurus

development of body, color, eyes and fins. Mr. Phillips values the fish at one hundred dollars.

During the summer months "thin out" goldfish—keep fewer fish in each aquarium. The water is warm and in consequence will not support as many as in winter. Under no circumstances should ice be placed in the tank to reduce the temperature, as is sometimes advised.

It is the hard jobs that make us.

The Aquarium Vacuum Cleaner

The Acton Electric Company, manufacturers of a famous tungsten lamp, has placed on the market an ingenious invention that will fill a long-felt want of the aquarist. The euphonious name, "Aquarium Vacuum Cleaner," in itself explains the purpose of the device, which retails at fifty cents to one dollar, according to size.

Several members of the firm, themselves practical aquarists, came to the conclusion that the old-fashioned method of syphoning sediment from the aquarium with a hose, or its tedious removal with a single dip tube, was an aggravation and could be improved; hence the vacuum cleaner. With it but a few minutes will be consumed in cleaning the bottom of the largest aquaria. It is merely necessary to close the end of the tube with a finger, then insert the other in the aquarium with the orifice close to the bottom. Releasing the finger will cause a rush of water, carrying the dirt into the reservoir. The operation may be checked at any time by replacing the finger. To empty the cleaner it is only necessary to turn it upside down. We have no hesitancy in commending this invention. Every reader should have one.



thorough in its work as the aquarium vacuum cleaner its success is already assured. Aquarists should hail with delight any device that makes labor light.

PETS: THEIR HISTORY AND CARE. By Lee S. Crandall. 372 pages, 138 illustrations from life.

Every normal person has an innate love of wild things and a desire to have them about him. Few individuals have not at one time or another had a pet, and the term pet is an exceedingly broad expression, usually though not always given to forms of life evincing some degree of intelligence in their actions. In this admirable volume the author conducts one through the whole gamut of pet life, from the lowest to the highest. Truly it is "everyman's" book. In it one finds the history, care and habits of the dogs, cats, monkeys, cavies, rabbits, rats and mice; the birds—pheasants, peafowl, pigeons, bantams, cranes, ducks, geese, swans, hawks, owls, parrots, canaries and other small cage birds galore. Not the least interesting are the splendid chapters on reptiles, batrachians, goldfish, native and exotic fishes, and the care and management of the aquarium. Every illustration is from a photograph. The author evidently recognized the fact that even the most accurate drawing falls far short of a photograph in fidelity to nature. The historical accounts of the various species are of such interest that many readers, whether they have pets or not, will read the book as a source of rare entertainment. The work is at once authoritative and comprehensive, though the author has wisely omitted mention of such forms as are beyond possession by an individual.

PETS: THEIR HISTORY AND CARE, costs \$2.00, plus postage on three pounds, and may be obtained from Aquatic Life Book Department.

AN ALBINO FROG

RICHARD DECKERT

Albinos, or animals lacking color pigment in their structure, are not rare. Animals like the rabbit, guinea pig, rat and mouse have been deliberately bred to albinism for hundreds of years. Occasionally an albino horse, dog, raccoon or opossum is met with, and among birds, geese, ducks, pea-fowl, guinea-fowl, crows and sparrows there often are true albinos.

Among reptiles, albino specimens of the milk snake, garter snake and alligator have been exhibited in the Zoological Park Reptile House. This year we are able to exhibit, for the first time in the United States, an albino frog. This interesting rarity, for such it surely is, was captured by Henry Snyder, the son of our Head Keeper of Reptiles, at Scarsdale, Westchester County, New York, and by him was presented to the Zoological Park.

When this specimen first was seen with some normally colored green frogs, it was thought to be a diseased specimen, but the young collector wisely considered it worth while to take home the specimen and show it to his father. Mr. Snyder immediately realized the rarity and importance of the find. Out of the thousands of frogs that during the past fifteen years have been caught for our reptile collection, no one who has caught and otherwise handled many thousands of frogs for quite a number of years ever previously has secured an albino specimen. The writer has recently examined all available records, and has failed to find any mention of an albino frog having been caught in the United States. Europe can show records

of several species of frogs and toads in which albinism occurs from time to time, but this is the first specimen recorded for America.

The specimen referred to is a common pond frog (*Rana clamitans*), such as may be found in almost any brook, ditch, pool or freshwater swamp. Its color is a waxy yellow white on all upper

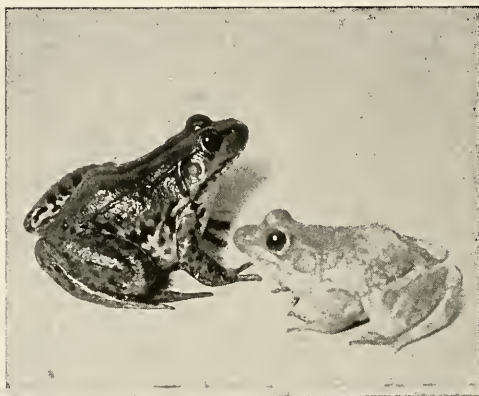

Albino Frog

Photographed with common color phase to show the marked difference surfaces, and milky-white beneath; the eyes are brilliant red, with a narrow gold rim around the pupil. Our specimen is a female about two and three-quarter inches in length of head and body, and therefore not quite adult. At first it was very timid, darting around its cage with nervous agility, bruising its head against the screen top and glass sides whenever anyone came near it. After nearly three months of captivity, however, it has lost its nervous fear, and will come from its hiding place under the moss provided for it and hunt the roaches, mealworms and earthworms which form its food. It will also sit for hours on a large flat stone in the

centre of its cage, apparently quite content with its surroundings.

Of course, this frog is enjoying special care, and we look forward to keeping it for a reasonably long time.

(Reprinted by permission, with courtesy of use of illustration, from the ZOOLOGICAL SOCIETY BULLETIN, New York.)

An Earlier Record

At the end of September a young student of the Packer Institute, of this city, told us of a curiously colored frog which she had caught a day or two before near her country home at Orient, Long Island. When the specimen was brought to us afterwards for identification, we recognized it at once as an albino leopard frog (*Rana halecina*).

The upper part of the body of the common leopard frog is green or brown in color, in both cases with a brilliant bronze lustre; the two folds along its back are bronze colored, standing well out from their darker base; upon its back are dark, round spots arranged in two lines, while the upper parts of the hind legs are ornamented with dark bars.

The specimen in question is a fully developed male, about three years old. The color of all parts of its body, seen from above, is a brilliant cream; while the underside of the specimen is pure white; along its back and on the hind legs the markings, characteristic to the species, appear indistinctly also in cream color, just a trifle deeper in shade; they can be made out by close inspection. The eyes are of a beautiful pink. Owing to the absence of dark colors in the skin, the animal has a very delicate appearance; it looks as if it was carved of ivory.

We have seen albino deer, fox, squirrels, ferrets, cats, raven, eel and years ago had an albino catfish (*Amiurus mar-*

moratus) in our collection, not to mention the more frequent albino rabbits, rats and mice, but for nearly half a century during which we collected and handled large numbers of every known species of batrachians, we have never before seen an albino frog, nor have we read or heard that anyone else ever has noticed such a freak in frogdom. It may, however, be safely said that this albino frog is the first one on record.

The specimen enjoys good health in one of the smaller aquariums of the Institute, where it is admired by the students at their leisure moments.

(The foregoing appears in the long since defunct magazine, THE AQUARIUM, in the issue of January, 1897, and was presumably written by the editor and publisher, Hugo Mulertt. While it invalidates Mr. Deckert's assertion of priority, it in no way detracts from the value of the record, and America may now lay claim to albinism in two frogs, each the first record for the species. The specimen described by Mr. Deckert is the Green Frog, *Rana clamitans*, which, by the uninitiated, is sometimes apt to be confused with the Bullfrog, *Rana catesbiana*, though the latter is a larger species. Mr. Mulertt's specimen is the common Leopard Frog, which he calls *Rana halecina*, a name that has since fallen into disuse, and in more recent works it will be found referred to as *R. Virescens* or *R. pipiens*. In his brief description of the normal colors it will be noticed that he places emphasis on the fact that the spots, two rows between the lateral folds, are round. They are not, however, always round, and are better described as "rounded" when considering a normal specimen, though variants occasionally exhibit round spots. However, it was evidently Mulertt's desire in this connection to make it clear that he had not confused the specimen

Aquatic Life

An international monthly magazine devoted to the study, care and breeding of native, exotic, gold and domesticated fishes, other animals and plants in the home aquarium and terrarium.

W. A. POYSER Editor
JOSEPH E. BAUSMAN Publisher
 542 E. Girard Avenue, Philadelphia.

Entered as second-class matter, September 2, 1915, at the Post Office, Philadelphia, Pa., under Act of March 3, 1879.

Practical articles and notes on topics pertaining to the aquarium and terrarium are always wanted for AQUATIC LIFE. Readers of the magazine are invited to join in making it a medium of mutual help, and to contribute to it any ideas that may occur to them. The pages are always open for anyone who has anything helpful and practical to say. Manuscripts, books for review and general correspondence should be addressed to the editor.

AQUATIC LIFE has the largest circulation of any magazine in the world devoted to this branch of nature-study. It presents to advertisers a market that can be reached through no other medium. Rates made known on application.

Yearly Subscription\$1.00
 Foreign Subscriptions 1.35
 Single Copy10

Payments may be made by money order, draft or registered letter. Foreign remittances should be by international money order. If local checks are sent, ten cents should be added for collection charges.

Copyright 1917 by Joseph E. Bausman

Vol. II June, 1917 No. 10

with the somewhat similar Pickerel Frog, *Rana palustris*, which has "squares" spots on the back. That both specimens were collected in New York is interesting.—*Editor.*)

Philadelphia Goldfish Fanciers

The regular meeting of the Philadelphia Goldfish Fanciers' Society was held on May 16th, at 802 West Girard avenue. Annual competition for Shubunkins and Comets. Judges, George E. Wilt, George B. Smith and William Hartman.

AWARDS: *Shubunkins*, blue, red and

yellow ribbons to Joseph E. Tyler; *Comets*, blue, red and yellow ribbons to Charles Ehrmann.

NEW MEMBERS: George Merkle and Addison T. McCarrick.

The competition at the next meeting, June 20th, will be for novices. Any fish or any member having previously won a ribbon in any society will be barred. The Joseph E. Tyler Cup and ribbons will be awarded.—FRED RICHARDSON, *Secretary.*

Notes on Hybridization

C. E. Crompton, of Duckabush, Wash., has reported interesting observations regarding the results of crossing the female chum salmon *Oncorhynchus keta* with the male humpback *O. gorbuscha*.

The development was normal with small percentage of loss, and the fry were very vigorous, smaller than chums, yet larger than humpbacks of the same age. In early development certain color changes were noted and the parr marks were retarded as compared with chum fry. An interesting fact was that two distinct color types became apparent at an age of about 25 days. About one-third of the number strongly resembled the humpbacks in their beautiful green coloring and absence of Parr marks, while the remainder developed irregular markings on the back and parr marks on the sides, the general color deepening with age to a dusky green similar to that of the chums. Serious abnormalities occurred in later stages and many fish died, but the majority survived in good condition. A few hundred are retained for further observation. — *Fisheries Service Bulletin.*

At the annual meeting of The Aquarium Society of Washington, Commander D. W. Todd, U. S. N., was elected treasurer.

Food Rings

In a thickly planted aquarium food spreads over the surface of the water, sinks between the plants, and may escape immediate consumption. To overcome this difficulty aquarists use a food ring, several styles of which may be had from dealers. Two forms made of bent glass tubing are usually to be had, and occasionally a deep round type of blown



Glass Food Rings. Courtesy Aquarium Stock Company

glass, the most desirable of all. With a ring the food can be confined to the front of the tank, falls in one spot on the bottom, and is not apt to escape the fishes. The surplus can be removed with an Aquarium Vacuum Cleaner when it seems advisable.

Light by Reflection

For several years I had considerable trouble with my aquaria due to insufficient light. I decided to remove the tanks to my front basement, where I could conduct experiments without family criticism. Here the light was admitted by a single window forty inches square. I had one fifty-gallon aquarium and six smaller ones, ranging from six to thirty gallons capacity. The first year only the large tank thrived and it was directly under the window. The next season I moved it back five feet, put a thirty-gallon concrete tank under the window, and arranged the other five behind the large aquarium—seven feet from the light. I then covered the joists of the ceiling for a distance of ten feet from the window and across the entire basement with bleached muslin sheeting, hanging curtains of the same material where the ceiling covering stopped. I

later gave these curtains a coat of "Muresco," with a very little pink tint. The result was remarkable. The five small aquaria were entirely out of the line of direct light, yet with the intense reflection brought about by the curtains the plants thrived and retained the rich natural color usual under ideal conditions. The *Sagittaria* was rich velvety green, which is seldom evident when strong light prevails. This scheme may appeal to aquarium lovers who may have tanks so situated that abundant light is not possible.—J. HENRI WAGNER.

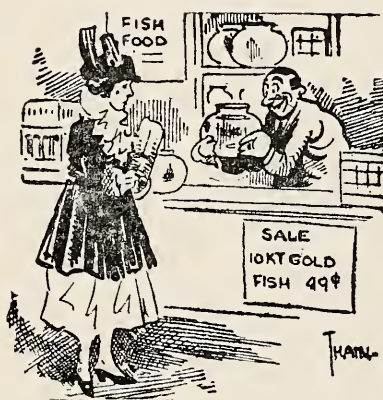

The Shopper—"Are these genuine goldfish?"

The Sales Person—"No'm, not at that price. These are only rolled plate."

The Essex County Aquarium Society, of Newark, New Jersey, held its second annual exhibition, lecture and auction, on April 25th. The attendance was remarkably large and gave every evidence of appreciation of the addresses by Prof. Lothair Smith, of Newark, and Mr. Harvery A. Van Cott, of Brooklyn.

Beautiful specimens of exotic fishes were shown by Messrs. Breder, Ball, Storsberg, Kniep, Thomas, Ludolff and Hoernig; Lionhead goldfish by William Feldman; splendid Black and Calico Broadtail Telescopes by Dr. Bachmann,

Dr. Coltorti, Messrs. Stief, Ludolff and Springer.

The auction was exceptionally successful and added considerably to the treasury. The society contemplates holding an exhibition during the latter part of September in the Newark Public Library Building to last a week. It will be open to sister societies and prizes will be offered in all classes. As "Newark knows how," the awards will be well worth while.—MAX G. HAMMERSCHLAG, *President*.

Ants Eggs Not Ants Eggs

For a long time the pupæ of ants have been a favorite food for certain cage birds, and to a degree for aquarium fishes. The material may be crushed and fed to the fishes dry or mixed with other ingredients of a prepared food. In the vernacular of the aquarist and bird fancier these objects are erroneously called ants' eggs. Before giving a brief outline of the life-cycle of an ant, and to understand it clearly, it may be mentioned that a typical insect passes through four distinct phases in its development from the egg to the mature form. The life-cycle begins with the egg, and then follows the larval stage (maggot, caterpillar, grub, etc., as variously applied to different classes). When the larva has reached full development it becomes quiescent, in some species forming a cocoon, during which period it transforms to the mature insect. Not all insects pass through the complete metamorphosis, and some, the dragonfly, for example, remain active during the pupal state.

There are numerous species of ants, each of which has some peculiar habit, but all are social insects and live in well-regulated communities or nests. Each nest contains one or more queens, numerous workers or undeveloped females,

who never have wings, and occasionally males.

The queen lays the eggs, and the workers tend them and care for the grubs or larvæ as they hatch. These grubs are kept in groups or nurseries assorted according to age. Other groups will be found composed of cocoons, and these are the miscalled "ants' eggs." From these cocoons, with the assistance of the workers, the perfect ants will emerge. The time taken by the grub before turning into the pupa or cocoon varies according to the species.

In summer great numbers of winged males and females are hatched. These swarm out of the nest and take a short nuptial flight. The fertilized females become queens and strip off their wings. They either return to the nest or start a new colony. The males soon die.

The proposed public aquaria for Baltimore and St. Louis are still hanging fire. Chicago is forging ahead with its plans, and will be satisfied with nothing short of "the best in the world." A quarter-million is in sight for the building and equipment, while the maintenance has been assured.

San Francisco has been saying little, but doing much. A public-spirited citizen has donated sufficient money for the building, which will be located in Golden Gate Park. A bill providing for the maintenance of the aquarium was approved at the last municipal election. Frisco has stolen a march.

Some aquarists ride all through the journey of life with their backs to the horses' heads. They are always looking into the past. They are forever talking about the good old times, and how much better the goldfish were years ago. There are no great goldfish now, and no real breeders. The very winters and summers are nothing to what they used to be. Do you know this man?

"AQUARIA FISH"

A practical work on care and breeding of fish in the Aquarium, Greenhouse and outdoor Ponds. Finely illustrated. Every one interested in keeping fish should send for a copy of this book. Price, \$1.

Four-Horned Snails (*Ampullaria Gigas*) deposit a mass of large coral red eggs out of the water, the little snails drop into the water as they hatch. These snails are invaluable for destroying Hydra in the aquarium.

Thoroughbred Collie Pups, beautifully marked.

F. L. TAPPAN

92 S. 7th Street, Minneapolis, Minn.

GOLDFISH SPAWN

From Choice Telescopes & Japs, \$2 per 100 Eggs

I. X. L. Regular and Baby Fishfood, 10c. Box

W. E. WALP

1309 NORTH 55TH STREET PHILADELPHIA

LORQUINA—The Naturalist's Monthly of the Southwest is published monthly by the Lorquin Natural History Club, and contains original observations of naturalists, particularly of the West. Associate membership, including subscription, \$1.50 per year.

LORQUIN NATURAL HISTORY CLUB,

1051 West 23rd Street, Los Angeles, Cal.

GEORGE'S GOLDFISH SHOP

Goldfish of All Varieties

George's Imperial Fish Food : 10c Postpaid
Dried Shrimp : : Box 10c, per pound 60c

Plants Aquaria All Supplies

N. W. 60th and De Lancey Street, Philadelphia

EDWARD S. SCHMID

Emporium of Pets

All Kinds of Goldfishes and Aquatic Plants
Water Lilies

712 Twelfth Street, N. W., Washington, D. C.
Taxidermy Send for Catalog

**BETTER CUTS AT
BETTER PRICES**

PROMPT SERVICE GUARANTEED

GOULD-WILHELM CO. INC.

ARTISTS * ENGRAVERS * PHOTOGRAPHERS

44 N. 4TH STREET PHILA.

SEND FOR SAMPLES AND PRICES THEY WILL INTEREST YOU

Otto Walter

86 Suydam Street :: Brooklyn, N. Y.

Near Evergreen Avenue L Station

Breeder and Importer of

TROPICAL & GOLDFISHES

Telescopes Calicos Japs Fan-tails

Dealer in All Varieties of Aquatic Plants

All Kinds of Fish Foods

Fresh and Dried Daphnia

AQUARIA, UTENSILS AND SUPPLIES

Fine Broad-tail Telescopes

BLACK & CALICO

Correspondence Solicited

GEORGE WILT, 1519 N. 62nd Street
PHILADELPHIA

EVERYTHING IS FISH THAT COMES TO THE NET OF A NATURALIST

Don't paddle in the water with one hand and be blind with both eyes. In other words "keep your eyes open" for all nature.

Our Magazine

The Guide to Nature

Will Help You

It is edited by EDWARD F. BIGELOW, who fishes in the heavens and earth, as well as the waters under the earth.

Four months' trial, 25c. One year, \$1.00

THE AGASSIZ ASSOCIATION

Arcadia

Sound Beach

Connecticut

LIVE DAPHNIA

The only ideal natural food for baby goldfish and tropical fishes. Feed it to your young and watch them grow. 50c and \$1.00 per can. Shipped by express to any part of the country. Remit by stamps or money order.

Frank Jenne, 231 Grand St., Hoboken, N. J.

Use Regenia Aquarium Salts

To replace the natural salts in your aquarium as absorbed by the fishes and snails. Excellent for plants. Help the snails form shell. Benefits the fish. Box of Six Powders, 25c. For sale at Pet Stock stores

Violet-Ray Fish Remedy

Relieves Constipation, Fungus, Tail Rot, Congestion. Safe and effective. Box of Six Powders, 25c. For sale at Pet Stock Stores, or address

REGENIA CHEMICAL CO.

Station K.

Philadelphia

The "BEST YET" Line
Brind Brand

(Reg'd Trade Mark.)

Covers EVERYTHING GOOD that
the Aquarist needs, namely:



1. "BEST-YET" HEATED AQUARIUM (the only Tropical Aquarium made).
2. "BEST-YET" FISHFOOD (the product of twenty years' practice).
3. "BEST-YET" GLASS SCRAPER (keeps Aquarium Glass clear).
4. "BEST-YET" DIRT REMOVER (METAL). Keeps Aquarium sanitary, fishes healthy and won't break.
5. "BEST-YET" PLANT FERTILIZER AND HYDRA DESTROYER. Nothing like it!

Send stamp for special circular!

Preserved Daphnia Live Enchytrae

(See my May ad!)

Tropical Fish in Greatest Variety
AQUARIUM PLANTS. Best Assortment!

"Domesticated Fish"

First and Best Book, covering Gold and Tropical Fish exhaustively. Price, \$2.60, with Supplement or \$2.08 without. Order NOW!

N. B.—The Entire "BEST-YET" Line is only obtainable from myself, the manufacturer, W. L. BRIND, 449 West 206th Street, New York City. (Phone St. Nicholas 8418 before calling.)

Winners

My Broad-tail Telescope Goldfish were awarded firsts and three special prizes at the last annual exhibition of the Aquarium Society held in the American Museum of Natural History, New York. Young stock from these fine fish for sale during the coming season. Watch my future ads.

Otto Gneiding's Goldfish Hatchery

31—37 Depot Ave., Ridgefield Park, N. J.

HERMAN RABENAU, Aquarist

PERMANENT DISPLAY OF

Aquatic Life & Terraria

must be seen to be appreciated

Visitors Welcome

Plants and Tropical Fish a Specialty

Importations of New Varieties received
regularly

1163 Myrtle Avenue, Brooklyn, N. Y.

Near Broadway.

THE BRUCE FISHERIES

Breeder, Importer, Wholesale & Retail Dealer in

All Kinds of Goldfish

Comets a Specialty

ELGIN K. BRUCE, THORNBURG, IA.

FRANKLIN BARRETT

EVERYTHING COMPLETE FOR THE
AQUARIUM, POND AND LAKE

Wyoming Avenue, & C Street, Phila., Pa.

SEND FOR PRICE LISTS

THE TERMINAL PET SHOP

PETS OF EVERY DESCRIPTION AND KIND

Manufacturing and Maintenance of Aquariums a Specialty

All Kinds of Cat and Dog Foods and Medicines

HUDSON TERMINAL BUILDING

Concourse, New York

CALICO JAPS & TELESCOPES

Young of Good Quality \$2 and \$3 Dozen

Orders under \$5 add 25c for shipping can

GEORGE A. SCHENK

29 Claremont Place

Mount Vernon, N. Y.

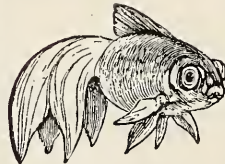

All aquaria fish thrive on
RELPAW Imported Hygienic
Natural Fish Food, 10c Box
Ask Any First Class Dealer

N. WAPLER, Importer
28 Warren St., N. Y. City

FOR SALE—Hundreds of Guppies (Lebistes reticulatus.) The most beautiful ones you ever saw. Your choice 25c each. Helli, 75c each. Several varieties of Snails.

V. VARJE, 1361 N. Clark Street, Chicago, Ill.

Telephone, Superior 4415

New Aquarium Book

This richly illustrated volume is of highly practical value to every aquarist, no matter what his specialty. Goldfish culture in all its branches; magnificent photographs of prize-winning specimens, etc., etc. Gives the only comprehensive list of 300 tropical fishes, their breeding habits, required temperature, food and general care in detail.

It will be entitled

GOLDFISH VARIETIES AND TROPICAL AQUARIUM FISHES

By *Wm. T. Innes*

Sent anywhere upon receipt of price, \$3.00, by the publishers.

INNES & SONS

129 - 135 N. 12th Street

Philadelphia

TEN VARIETIES OF BEAUTIFUL AQUARIUM PLANTS

for \$1.00 Postpaid

J. HENRI WAGNER, 1909 North Capitol
Washington, D. C.

ONCE TRIED YOU'LL ALWAYS BUY

Mack's Superior Fish Food . . . 10c
Mack's Special Prepared Baby Fish Food 15c
By Mail 12c Can Ground Shrimp 70c lb Wholesale to Dealers

All Stores or **H. J. MACKRELL**

2816 Jasper Street, Philadelphia, Pa.

AQUARIUM STOCK CO

150 Chambers Street :: New York City

Aquarium Specialists

GOLDFISH, FOODS, PLANTS, SNAILS, ETC.

Combination Natural Fish Food - Sample Can 10c
Imported Shrimp Fish Food - - Sample Can 15c
Imported Wafer Fish Food Large Sample Box 10c

Special Prices on Quantity Lots Cash With Order

Catalogue Sent Upon Request

Orders amounting \$2 delivered postpaid.

Mail orders promptly attended to.



DEALERS

Do you want a big seller that you can guarantee will give satisfaction and make friends for you?

Our Aquarium Vacuum Cleaner Will Do the Trick

List this article in your catalogues.

*Samples by Parcel
Post, 50c, 75c, \$1.00*

Liberal discounts to legitimate Dealers and Jobbers.

Mfg'd by

Acton Electric Co., Inc.

1133 BROADWAY

NEW YORK

Patents Pending

WALTER BELL

Breeder of Broad-tail Telescopes

BLUES

BLACKS

CALICOS

4324 WYALUSING AVENUE, PHILADELPHIA

Prices Reasonable

CARL LAZER

Dealer and Breeder of Tropical Fishes

Aquarium Plants Red Snails

All Kinds of Aquaria and Supplies

Open Evenings and Sunday

647 West 184th Street New York City, N. Y.

CRESCENT FISH FARM

Breeders and Collectors of

Goldfish and Other Aquarium Fishes

Alligators, Turtles, Chameleons, Snails, Water Plants

We are now booking orders for Fall shipments of *Mollienisia latipinna*, *Gambusia holbrooki* and Paradise Fish

1624 Mandeville Street, New Orleans, La.

Michaelsen Bros

**GOLDFISH
BREEDERS**

FLORISTS

58th and Walnut Streets

110 South 52nd Street

Philadelphia

Aquarium Fishes

All Kinds of Aquatic Plants

Aquaria & Supplies

Wholesale and Retail

Nippon Goldfish Co

1749 Buchanan Street, San Francisco, Cal

Importers : and : Dealers

JAPANESE GOLDFISH

DIRECT FROM BREEDERS IN JAPAN

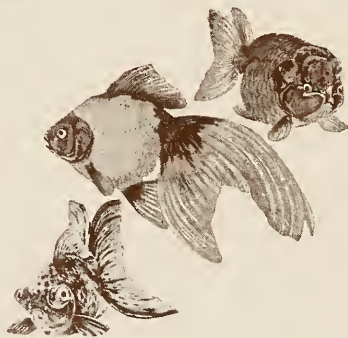

Awarded Gold and Silver Medals

Panama-Pacific International Exposition
San Francisco, 1915

ALL KINDS OF AQUARIA AND SUPPLIES

Price Lists Furnished to the Trade Only

HARRY P. PETERS

1210 N. Warnock Street, Philadelphia, Pa

BREEDER AND IMPORTER

Rare and Fancy Fish

Plants of every variety, Snails and
Aquarium Supplies of all kinds at all
times.

MANUFACTURER OF

Green River Fish Food

15c Box

Green River Baby Fish Food

20c Box

A GOOD FISH FOOD is one of the
most essential things necessary to
keep fish in good health. After the
test of years Green River stands out
as the best food on the market. It
keeps the fish in good color by pro-
moting a healthy, robust growth. It
will not sour or cloud the water. Ask
your dealer or send for it today.

Breeders

A large assortment of splendid Telescope
and Jap goldfish at reasonable prices.

Fine Assortment of Lionheads

Shipping Cans, 45 Cents.

HARRY P. PETERS

1210 N. WARNOCK STREET

PHILADELPHIA

GREEN RIVER FISH FOOD

Due to the constant increase in
costs of ingredients, boxes and print-
ing, it has become necessary to in-
crease the price of these foods to 15
and 20 cents. When conditions again
become normal the old prices will
again prevail.

HARRY P. PETERS,

1210 North Warnock Street,

Philadelphia, Pa.

50,938

July, 1917

10c Copy

Aquatic Life



H. Goodby
MIL. 1916.

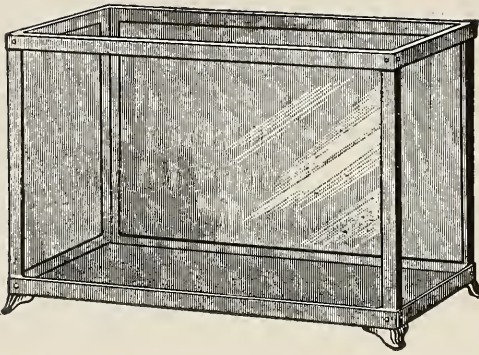

Jacob C. Cassel

915 Arch Street, Philadelphia, Pa

Manufacturer of

AQUARIUMS

Aquarium Ornaments

Floral Terra Cotta, Etc.

Goldfish Fish Globes Fish Food

and all aquarium requisites.

Send for Catalog.

Aquarium Specialty Co. 414 E. TREMONT AVENUE NEW YORK CITY

MANUFACTURERS OF AQUARIA, FOUNTAINS, TERRARIA, VIVARIA

BREEDERS OF DOMESTICATED FISHES

IMPORTERS OF FOREIGN FISHES

AQUATIC PLANTS, SNAILS AND SUPPLIES

STOCK AQUARIA

Galvanized Metal Frame, Enameled and Gold-Striped, Bottom Slate or Ribbed Glass. Plain. On legs

No. 1.	11"x7"x7"	\$1.25	\$1.50
" 2.	14"x9"x9"	1.50	2.00
" 3.	17"x11"x11"	...	2.25	2.75
" 4.	20"x13"x13"	...	3.00	3.75
" 5.	24"x12"x14"	...	4.75	5.50

20% additional for oxidizing.

Solid Brass Frame, on Projecting Slate Bottom or on Legs.

No. 1.	12"x 6"x 8" high,	2 1/2 gal.	\$2.50
" 2.	14"x 8"x10"	" 5 "	3.25
" 3.	16"x10"x12"	" 9 "	4.75
" 4.	18"x12"x14"	" 14 "	5.75

20% additional for nickel-plating or oxidizing.

Steel Angle Frame, Heavy Plate Glass, Slate Bottom, Flush or Projecting.

No. 3 1/2.	24"x14"x14",	22 gal..	\$8.00
" 4 1/2.	30"x16"x16",	36 " ..	12.50
" 5 1/2.	36"x18"x18",	54 " ..	20.00
" 6 1/2.	42"x20"x20",	80 " ..	35.00
" 7 1/2.	48"x22"x22",	110 " ..	60.00
" 8 1/2.	54"x24"x24",	145 " ..	95.00
" 9 1/2.	60"x26"x26",	180 " ..	135.00

All our aquaria are so constructed that water cannot come into contact with the metal.

All sizes and shapes made to order. We charge only actual cost for packing and cases.

FISH FOODS

	Per Tin box.	Per lb.
Natural Fish Food.....	\$.10	\$.50
Universal Fish Food...	.15	2.00
Ground Dried Shrimp..	.10	1.00

	Per Tin box.	Per lb.
Ground Dried Flies and Insects20	3.00
Ground Dried Daphnia..	.20	\$3.00
Infusoria Creating Food ..	.15	2.00

Correspondence Solicited. JOSEPH TAUBLES, Manager. No Catalogues

IF YOU

Are Looking for Something Extra Fine in Broad-tail Telescopes

Don't Forget W. H. HEIMBACH

Breeder and Importer of FINE FISH Snails Plants

FISH FOR SALE AT ALL TIMES!

413 NORTH TENTH STREET
ALLENTOWN, PA.

MECCO GARAGES

Here is a chance to make money

Write for Proposition Give References

- ADDRESS -

M. E. Corrugating Co.
COVINGTON,
KENTUCKY





The Mud Minnows With Notes on the Order Haplomi*

DR. R. W. SHUFELDT, C. M. Z. S.

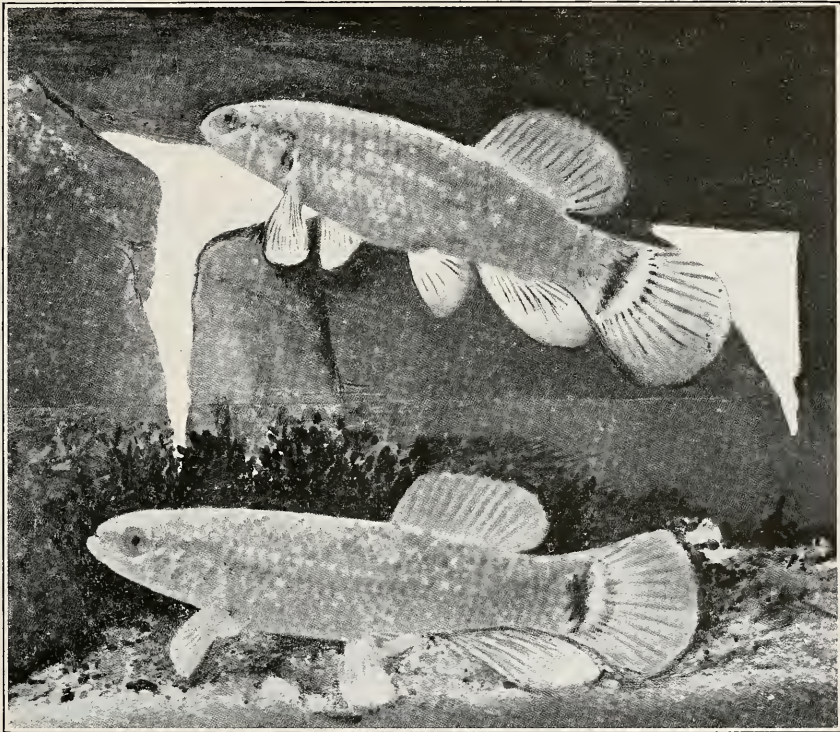

Upper and lower figures of the same specimen of *Umbra pygmaea bilineata*; natural size, from life
Reproduction of photographs made by the author. Note in the lower figure
how the fish rests upon its fins on the bottom

We have in the North American fish fauna a group of pike-like fishes, which have been associated in an order, *Haplomi*, by several of our most eminent classifiers of this branch of the vertebrata. This order has been created to contain four very interesting families, namely, the *Umbridae*, the *Lucidae*, the *Pocillidae*, and the *Amblyopsidae*, and I have paid some little attention to each

and all of them. They vary enormously with respect to the number of genera and species each contains, as the *Umbridae* or Mud Minnows, when Jordan and Evermann published their work on the Fishes of North America, in 1896, in its only genus *Umbra* is represented by

*Read at a regular meeting of the Aquarium Society of Washington, on Thursday evening, the 15th of March, 1917.

but two species, namely *Umbra limi* and *U. pygmaea*; the *Lucidae*, with the single genus *Lucius*, or the pikes contained in some seven species; the *Poecilidae* or Killifishes includes some twenty genera, with an enormous number of species. Finally we have the *Amblyopsidae*, or blind fishes of the caves, with three genera and some five different species.

Of all these I have paid more attention to the pikes; that is, in so far as their structure is concerned, and, to tell the truth, while we know something of the anatomy and the relationships of this host of forms, we are, for the most part, woefully ignorant of nearly everything concerning it. Dr. David Starr Jordan, in touching upon this matter, has said: "While our knowledge of the osteology and embryology of most of the families of fishes is very incomplete, it is evident that the relationships of the groups cannot be shown in any linear series, or by any conceivable arrangement of orders and sub-orders. The living teleost fishes have sprung from many lines of descent; their relationships are extremely diverse, and their differences are of every possible degree of value."

This difficulty will ever confront us, and we will remain in the dark as to the vast majority of the relationships of extinct and living forms of teleostean fish,—indeed of all fishes, until we are more familiar with their structure or morphology. It has been and is now shamefully neglected. For many years past I have collected osteological materials of many of our best-known bony fishes, and photographed their skeletons. In some instances descriptions have been written out; but all my efforts, in many directions, failed of publication in the United States. At this writing there seems to be very considerable hope that a good part of it will be published in Australia, where the value of such information is

keenly appreciated and sought after.

The mud fishes of the genus *Umbra* are found in Austria and in this country. As a genus, according to Doctor Jordan, they are characterized by having no *lateral line*; the scales are of medium size and unstriated (cycloid type), with external characters easily studied in my photographs of *Umbra pygmaea*, specimens of which I have kept in aquaria for months together, in that I might study the habits of the species and make photographs of them. Two of the latter, made by me from life in February, 1917, are here reproduced to illustrate the present article. I know of but two species of *Umbra* that have thus far been described as belonging in our fish fauna, that is, *U. limi*, of the central section of the United States and lower Canada, with the form very closely related to it, the above mentioned *U. pygmaea*, which has been called the Eastern Mud Minnow. It is said to range from Long Island to the Neuse River, being often abundant locally. My specimens of *Umbra* are from swampy holes along the Potomac River, near Washington, where I captured them myself.

Recently I have made some studies of *Umbra limi* and *Umbra pygmaea*, and carefully compared them. Most of the material studied by me belongs to the collection of fishes in the Division of Fishes of the United States National Museum, and I am greatly indebted to Dr. Barton A. Bean, curator of that division, for his kindness in placing all that material before me, as well as for inviting my attention to various published accounts of these different species of mud minnows of the genus here to be considered. I have also studied living specimens of the form of *Umbra* found in the District of Columbia, in one of the aquaria belonging to Mr. James E. Benedict, Jr., of Washington, D. C., to which

he kindly invited my attention. There is also an interesting living specimen of the same species, from the same locality, in the possession of Mr. Edward S. Schmid, of Washington, D. C., who has kindly allowed me to examine it.

While I have seen the specimens of the Austrian form (*U. umbra*) belonging to the United States National Museum, I have not very critically studied them. It is quite nearly related to the species we have here in the United States, and it presents the common generic characters.

Coming first to the literature of the *Umbridae*, it is found to be more or less extensive, especially in view of the fact that the family is so very small, and the species contained in it have no economic value whatever. In some waters these Mud Minnows are preyed upon by larger fishes. In the "Zoölogy of New York," by James E. De Kay (Albany, 1842), there is a brief account of *Umbra pygmaea* (p. 214); but the plate is not numbered, and the colored figure of the fish is of no value whatever, the coloring being entirely incorrect; the fish's form wrong, and the specimen only 3.7 cms. long. I have examined all that Jordan and Evermann say in their "Fishes of North and Middle America." In Part IV of that work these authors give a cut of *Umbra pygmaea* (Fig. 268) which is 10.9 cms. long, and which I take to be a *typical* example of that species. It agrees with the description given in Part I, page 624, to which reference will be made further on.

There are good accounts of these Umbrids in the following works, all of which I have carefully read and compared:

1. "A Remarkable Genus of Fishes—the Umbras," by Theodore Gill (Smithsonian Miscel. Coll., Vol. 45, pub. April 11, 1904). Five figures, pp. 295-305.

This brief paper gives a good cut of the European *Umbra* (*U. umbra*), and three of *U. pygmaea*, of which Fig. 38 is given incorrectly as the Western *Umbra* (*Umbra limi*), it being the aforesaid cut from Jordan and Evermann of *U. pygmaea*.

2. "Catalogue of the Fishes of New York," by Dr. Tarleton H. Bean, Bull. 60, Zoöl. 9, New York State Museum, Albany, 1903 (p. 287). Brief scientific and popular account of the American species of *Umbra*.

3. "The Fishes of New Jersey," by Henry W. Fowler. Ann. Rep. New Jersey State Museum, 1905, pp. 180-183, pl. 16. Plate 16 is of the Mud Minnow, *Umbra pygmaea*, an enlargement of Jordan and Evermann's figure, brought up to 18 cms. in length (about seven inches), which is much larger than the fish ever grows to be. It gives 38 scales instead of 35, and 12 dorsal rays instead of 13; it has too many anal rays.

As a matter of fact, none of the descriptions of the external characters of these Mud Minnows, as given by the various authors cited above, seem to tally. As already pointed out, Gill figured *Umbra pygmaea* for *Umbra limi*. Fowler, who goes quite exhaustively into the external measurements, etc., in *U. pygmaea* (pp. 180-181), says, among other things: "D II, 12, A III, 6. Scales 30 in lateral series to base of caudal and three more on latter," and so on with a lot of measurements. This does not agree with Jordan and Evermann given above. Dr. Tarleton H. Bean calls *Umbra pygmaea* the "Striped Mud Minnow," and agrees with Jordan and Evermann in the number of fin rays and scales. It is not unusual to find these particular points in agreement in *U. limi* and *U. pygmaea*. For example, Doctor Bean gives for *U. limi* D. 14; A. 9., and scales in lateral line 35.

The habits of these Mud Minnows, especially those of *U. pygmaea*, in nature and in aquaria, have been quite fully described in the articles cited above by Doctor Gill and Doctor Bean; they agree with my own observations, and they are surely quite remarkable. Indeed, the European *Umbra* (dogfish) was described as early as 1726 (Marsigli), and again in 1756 (Kramer), while a great many naturalists have referred to these fishes since, the best known account having been rendered by Heckel and Kner (1858), C. C. Abbott (1884), L. Kathariner (1899), and others. See also "Fishes of Illinois," Forbes and Richardson, pp. 203-205.

There is one point worthy of notice here that will, in part, account for the remarkable differences to be found in the descriptions of the external coloration of the Eastern Mud Minnow given by the authors mentioned above. In the first place, the fish changes its coloration to a wonderful degree when placed in alcohol and other preservative fluids. Then, in life, the fully adult specimens (4 to 4½ inches long)—the young ones, too—change their color to such an extent as to appear like an entirely different fish; this is particularly true of *Umbra pygmaea*. The changes are due to causes similar to those that produce them in some lizards, as *Anolis*, or any of the chameleons. Sometimes it will be of a deep umber brown, with all the markings in strong relief; when, again, it will have a general color of a pale clay tint, with all the markings, or most of them, still more in evidence. These facts should be borne in mind, and I have failed to find them stated in any of the accounts I have read of the fish.

As stated above, at the U. S. National Museum I examined many specimens of *Umbra umbra*, *U. limi*, and *U. pygmaea*, and among the last named Nos. 16,806

(Trib. Chesapeake Bay); 72,442 (one large, one small, Laurel, Md.); 27,481 (Eastern Maryland); 68,321 (Long Island, N. Y., 6 specimens); 35,971 (E. Lake Patchogue, L. I., 1 large, 4 juv.); 67,455 (Laurel, Md., 2 specimens), and 60,797 (pool near Chain Bridge, D. C.) Some of these specimens agreed, in the main, with the figure and description of *Umbra pygmaea* as given by Jordan and Evermann, while others by no means did. It would seem that all collectors and describers of the Eastern Mud Minnow have, for more than a century, been so thoroughly satisfied that we find but one species of *Umbra* in the Eastern United States, that every one taken has been referred to it, whether it agreed with published descriptions of that species or not.

Now the larger specimen of the two in 72,442 of the above list has a length of 8.2 cms.; it is marked like one living in one of my aquaria—that is, the *longitudinal stripes* are practically absent. There is a single, whitish stripe running the entire length on either side, mesially; the general color is a rather pale clay brown, distinctly mottled with dark brown on the back. There are dark markings on the side of the head—one heavy one through the eye and one below it; chin very light. D. 14; A. 9. This specimen hardly agrees in a single particular with Jordan and Evermann's description of *U. pygmaea*. This is also true of No. 68,321 (the largest specimen, also largely so the smaller ones). It has a length of 7 cms., and is not markedly striped, while the above described whitish stripe is conspicuous; chin pale gray. D. 14; A. 8. No. 60,797, length 10 cms., caudal spot white, bordered with black; mid-lateral longitudinal stripe white; chin pale gray. D. I. 14; A. 8. Another specimen, or rather two specimens,

Continued on page 147.



Fundulus Chrysolus

ERNEST LEITHOLF

The Golden Fundulus is a native of the southeastern States, ranging from South Carolina to Florida. Notwithstanding the generic name *Fundulus*, which is derived from the Latin "fundus," meaning bottom, this species is a pronounced surface fish. Chrysolus means golden.

The male and female are both attractively colored, but very distinct from each other. Were it not for the similarity in shape, one would be inclined to think them separate species. As a matter of history, Jordan described the female as a new species, in the Proceedings of the U. S. National Museum, 1879, calling it *Zygonectes henshalli*. Even authorities may err! The male is speckled with reddish brown or wine-colored spots on a glistening ground of bronze green, suggesting upright parallel lines. The effect of the spots is very variable, being pronounced on some fish and on others entirely absent. The gill covers are adorned with a large shining green spot; dorsal, anal and caudal fins with reddish spots; ventrals and pectorals colorless. The female upon a warm, mellow olive ground color displays glistening silver spots, these in a certain light assuming a greenish cast. The cool silver in contrast with the warm background produces a striking effect. The gill covers, like those of the male, are green. Other than by coloration, the sexes can be distinguished by the larger anal and dorsal fins of the male.

Breeding in the aquarium is not difficult, though it is well to maintain a tem-

perature of 75 degrees, Fahrenheit. The antics of the male in courting his mate are interesting. At times he will swim directly above her, or, trembling violently, be at her side. When ready to deposit an egg they will approach, swimming side by side, the place selected, which may be a protruding stone, the

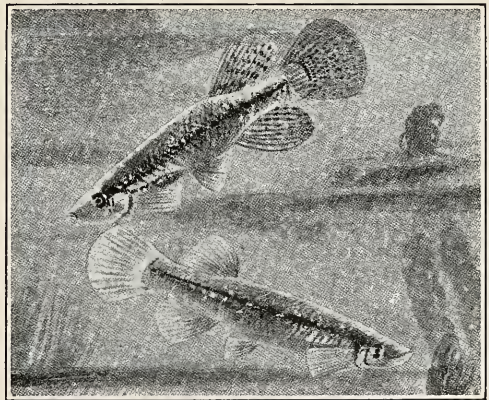

Fundulus chrysolus

side of the aquarium or a group of plants. Generally I have found them to prefer the roots of floating plants, such as *Salvinia* or Water Hyacinth. During the orgasm the male presses closely to the side of the female, then with vehement trembling and sidelong twisting an egg is expelled and fertilized. This may occur from ten to twenty times daily for a week or more. My largest day's find has not exceeded ten eggs, but no doubt some were devoured and others overlooked.

The eggs hatch after ten to fourteen days' incubation. Beautiful babies they are! Examine one with an ordinary hand magnifying glass and it appears as

if studded with tiny sparkling diamonds. After a few days these radiant spots disappear, but reappear on the females as they approach maturity. The males develop the reddish spots.

Considered from all viewpoints, the Golden Fundulus is worthy of a place in every collection. It endures well—I have had specimens for three or more years.

Riccia Fluitans

JACOB MERGET

There was a time when *Riccia fluitans* was considered of little value in the aquarium, but in those days little attention was given to the exotic fishes. The books gave it passing mention, with the

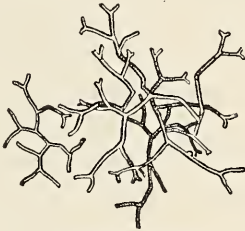

Riccia fluitans

information that it was a poor oxygenator.

Riccia is a liverwort, one of the so-called flowerless plants, and is related to the mosses. The plant consists of a bright green, expanded and irregularly forked thallus, floating at the surface of the water with the tips thrust above. Growth is by repeated branching and ball-like clusters are gradually formed. These when broken by the activities of the fishes, or otherwise, form nuclei for other balls, until finally a blanket of green is literally thrown over the surface of the water in the aquarium.

The value of such a covering becomes evident when we breed certain fishes, and particularly those species which deposit their eggs near the surface. To these it offers an ideal place for oviposition. Not less in importance is the fact

that it harbors countless myriads of protozoans (infusorians, rotifers, etc.), which is the necessary food of the resulting young fish. The oxygenating power of such a mass is not inconsiderable.

The cultivation of this plant does not present any particular difficulties. The main requirement is to disturb it as little as possible. It will do well in a glass-covered aquarium in the sunlight, or with little sunlight. I have grown fine clumps in half-pint jars. Algae are its serious enemies, and a contest between the two usually results in the ultimate disappearance of *Riccia*.

While the species is a native, and thus may be collected in ponds and ditches, this wild material must be introduced with caution, as with it may come some of the pests that work havoc among young fishes. It will be better to start with a little secured from a fellow aquarist, or, if the pond plants are collected, to take them in small lots, examine carefully, and then place in "quarantine" for a time. *Riccia* was named in honor of P. F. Ricci, an Italian nobleman, patron of the botanist Micheli.

Not alone in color do fishes resemble birds. In the home life and love of offspring a close resemblance obtains. Many are nest builders, erecting structures quite as complicated as those of some birds, and hardly less elaborate in design and finish.—*Dr. Thomas G. Gentry.*

It's the easiest thing in the world for a man to deceive himself.

I am very much pleased with AQUATIC LIFE and fully enjoy every issue. With its assistance I have come to a fuller appreciation of an aquarium, and have been able to make the large one in my office more attractive and of greater interest.—*Russell T. Neville.*



Belonesox Belizanus

WALTER LANNOY BRIND, F. Z. S.

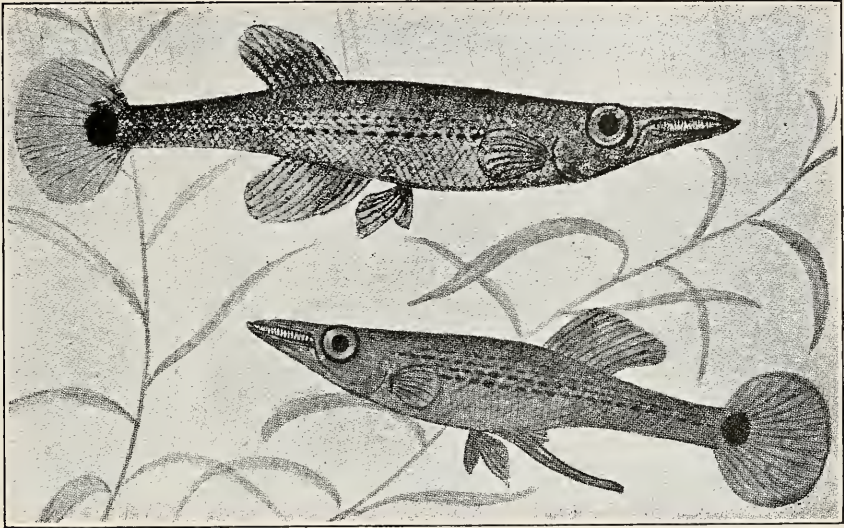

This peculiar aquarium fish is a native of Belize, British Honduras; hence the specific name *belizanus*; *Belonesox* means Silver Gar-pike. Though this name suggests relationship to the pike and pickerel family, the connection is not particularly close, and it is probably as closely akin to our favorite *Gambusia affinis holbrooki*, which is also live-bearing.

In point of color *Belonesox* is not remarkable. A dull grayish-olive on the back or dorsal region shades to a bluish leaden tint on the sides; abdominal area whitish; gill-covers with a shimmer of metallic green. All the fins are watery-olive or transparent, the anal fin of the male being modified into a conspicuous intromittent organ. A black spot at the

base of the tail gives the species a certain neatness and finish. Males attain a length of six inches; females, seven inches.

The live-bearing pickerel, for such we may call it for sake of popularity, partakes of the disposition of our native pickerel in its method of feeding and choice of foods. A tender, young fish is the racy tidbit it demands. From a hiding place amongst the plants it will rush out to capture and swallow (all practically in one movement) any small fish luckless enough to venture near. A glance at the illustration is sufficient to give a wholesome conception of the power of the alligator-like jaws of this rapacious rascal.

A temperature of 70 to 75 degrees.

Fahrenheit, seems to meet the needs of this fish, though it is not particularly delicate in this respect. Sudden changes, especially from high to low, are injurious to this and all other warm water fishes, and must be carefully avoided. *Belon-sor* is ovoviviparous, and in breeding should be treated like the other live-bearing species. Due to its voraciousness it is rather difficult to save the babies.

More on account of its peculiar form and greedy habits does this fish appeal to the aquarian, and particularly to those having an over-abundance of young fishes with which to sate its appetite! I prefer to pass it up; such maintenance is too costly.

The Mosquitoes

The mosquitoes, family CULICIDAE, do not form a large insect group, but are an important one. They are a pest, and carry disease. They range from the tropics to Alaska, Lapland and Greenland. They are true air-breathers, but are born in stagnant water. They breed rapidly, and pass through several generations a year; the adults hibernating in outhouses, cellars and cold garrets. The main purpose of the adult seems to be propagation of the species; its life to be dependent only upon this opportunity. Females are normally plant-feeders, their mouth-parts very different from the flesh-sucking males.

Five genera are represented in this country: *Anopheles*, *Aedes*, *Megarhinus*, *Psorophora* and *Culex*. Most of our species belong to the genus *Culex*. Those of the genus *Anopheles* carry malaria. Those of the genus *Aedes* are very small; those of *Megarhinus* and *Psorophora* are large—known as gallinippers.

Eggs, numbering from 200 to 400, are laid in a raft-like mass, gray-brown from

above and silvery white from below. Laid in the early morning, the eggs will hatch, on a warm day, by two in the afternoon. The wigglers are very active, breathing at the surface, descending for food. The wiggler moults three times, reaches maturity and transforms to a pupa in a minimum of seven days, in hot weather; in cool weather this takes much longer. The pupa stage lasts two days, longer in cool weather, when the skin splits and the adult mosquito emerges.—Gayne T. K. Norton in *Nature-Study Review*.

The larvæ of mosquitoes form a food for aquarium fishes that is equal, if not superior, to daphne for those large enough to consume them. A number of successful goldfish breeders ascribe the rapid growth of their youngsters to the abundant use of wigglers. They may often be collected in quantity in pools, or in bays of slow-moving streams.

When using a rubber hose to syphon the sediment from the bottom of an aquarium it is a difficult matter to guide it about with precision. To overcome the difficulty take a strip of wood, a piece of an old box sandpapered smooth, measuring one inch wide and six inches longer than the aquarium is deep. Fasten the hose to the rod with three rubber bands—bottom, middle and at a point several inches from the upper end of the rod. After the syphon is started by a slight suck at the end of the hose, the other end, in the aquarium, may be moved about as desired. If plants, snails or stones are caught, a pressure of the fingers on the hose will stop the syphon and the object will drop, after which a release of the pressure will again start the water.

Promises may get you friends, but non-performance will turn them into enemies.

A History of Fish Culture

WILLIAM E. MEEHAN, Director, Philadelphia Public Aquarium

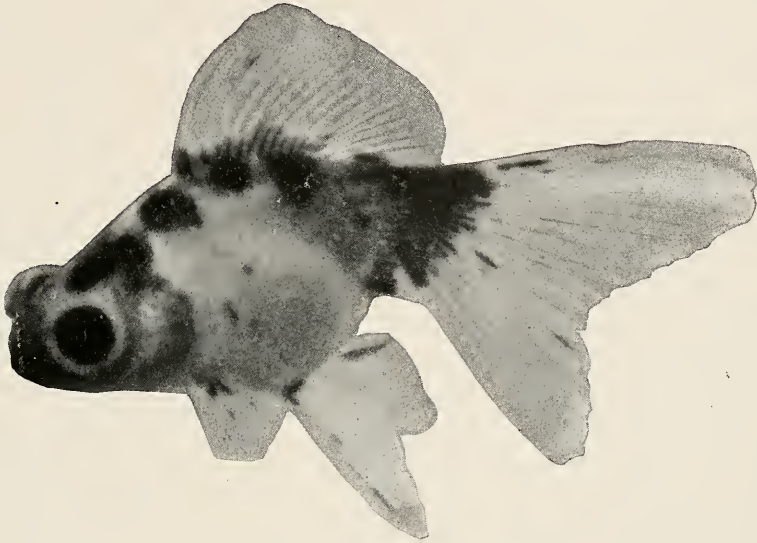

CALICO TELESCOPE GOLDFISH

Owned by Geo. E. Wilt

Photograph by H. W. Schmid

It is now generally accepted as a fact that fish life in fresh water streams and other bodies of fresh water can no longer be maintained, except in very remote places, by natural propagation. The steady growth in population, and the resultant increased demand for fish for food, has caused a greater drain on the supply than the fishes in nature can overcome. Hence, in order that the demand be met, it became necessary to assist nature by what is termed artificial propagation. If it were not for what is being accomplished by the fish culturist in this direction, it is safe to say that many of our familiar and best food and game

fishes would have long since been exterminated.

The fish culturist employs three methods of propagation: in troughs with water running over and under wire netting trays; by keeping the eggs revolving in glass jars filled with water; in ponds in which the fishes are allowed to spawn naturally, both mature and young fish being guarded from their many enemies. Only very heavy eggs, like those of the trout and salmon, are hatched by means of the troughs and trays. Semi-buoyant eggs and those which are yielded in vast quantities are hatched by the jar method. Pond culture is reserved for those fishes

from which eggs cannot be taken at all, or from which they can only be taken with much trouble or possible injury to the culturist. In this class are placed a few nest-building species that take vigilant care of both eggs and young, and where fertilization by natural methods is even better than by artificial expression.

Pond culture is the oldest of the three methods. The practice dates back to very ancient times. The Romans, the Greeks and the Egyptians all raised fish by that means. So did the Chinese. Indeed there is reason to believe they were the first. There are records showing that more than five hundred years before Christ a Chinese built a pond and dotted it with islands. The avowed idea being to fool the fish and make them believe they were in their natural environments, and that the islands were continents. The cute Chinaman placed about twenty fish in the pond. At the end of the first year the pond contained several thousand fine fish; by the close of the second, several hundred thousand, and at the end of the third there were so many that this pioneer fish culturist couldn't count them! That this man did business there is no doubt, but we are forced to the conclusion that he either outclassed Ananias or did better than any culturist since his time, for nowadays a man may count every fish he can raise by pond culture. In fact, pond culture produces less fish than any other method.

The artificial expression of eggs from fishes was discovered by a Jesuit in France during the latter part of the fifteenth century. He fertilized trout eggs and hatched them in a hatching box which he invented. His discovery made no stir and was forgotten after his death. This important feat was not learned until many years after, and then only by the accidental discovery of old records in the monastery in which he had lived.

In the middle of the seventh century, Count Jacoby, a German nobleman, re-discovered artificial fertilization and hatching of trout eggs. Curiously enough, his hatching apparatus was almost identical with that of the obscure priest. Jacoby was a scientific man and published his experiments and results. The pamphlet was translated into several languages, and excited widespread scientific interest, but no one seemed to think there would be any practical use for it.

It was not until after 1840 that fish culture by artificial expression and fertilization of eggs was put a practical use, and it is a curious fact it didn't come through the discovery of Jacoby. His work, like that of the priest, had been forgotten. The world owes practical fish culture to two Breton fishermen. These two peasants became interested in watching trout spawn, and they made what to them was an amazing discovery, that the eggs of the trout were not fertilized until after they left the body of the female. Wondering if the eggs could be pressed from the female, they tried it with success. They devised a hatching apparatus which proved successful, and then communicated their discovery to the French government. The officials were profoundly impressed and appointed one of the men, Gehin by name, a commissioner to instruct others in the new art. Gehin's partner in this work, Mons. Remy, was forced to drop out because of illness.

An American was among those who took lessons from Gehin, and he imparted his knowledge to a Dr. Garland, of Cleveland. Dr. Garland became enthusiastic, and fertilized and hatched a lot of salmon-trout eggs. A few years later, in the early sixties, William Ainsworth, a New Yorker, started a commercial trout hatchery. He was followed almost immediately by Seth Green, and

the commercial trout industry in the United States became a fact accomplished.

Seth Green was not satisfied to keep within one groove, and investigated other fishes. The outcome was the successful propagation of shad, whitefish and pike-perch, and the invention of the jar system, which now enables the National and State governments to hatch billions of valuable food fishes annually, and all from eggs which would otherwise be absolutely wasted. I say wasted advisedly, because the eggs of the whitefish, shad and pike-perch are from fishes taken in the nets for market.

While fish culture was not discovered in the United States, Americans have given it the greatest attention and made the greatest advances, consequently the United States leads the world in fish culture.

The Mud Minnows

Continued from page 140.

No. 67,455 of the above list, are also marked like large living specimens taken in the District of Columbia, including those in my aquaria; larger one 8.8 cms., D. II. 8 (fin imperf.); A. 8., smaller one 7.7 cms., D. 14; A. 8. Both are mottled on the back, and have the usual whitish or white lateral longitudinal stripe.

No. 27,481 of above list has a length of 11 cms., 10 longitudinal stripes, seventh one from belly nearly white and runs over top of percle to the eye; chin light, snout blunt. D. 14; A. 8. Scales 34. Agrees almost exactly with Jordan and Evermann's description and figure. No. 35,971, length 1 cm., striped; chin darkish; middle stripe white. D. II. 14. A. 8. Same species as the last. No. 16,896, length 11 cms., striped as in No. 27,481 above (12 stripes, the usual white one present); chin pale. D. I. 13. A. 8.

This specimen appears to be a typical or nearly typical *Umbra pygmaea*.

The longitudinal stripes in *U. pygmaea* seem to run from 10 to 14 in number, with an included median white or whitish one; the number of rays in the dorsal and anal fins also vary, as above indicated. I have yet to find a specimen with a "black chin." As the coloration is alike in the two sexes in this genus of Umbrids, the above differences cannot be attributed to sexual ones as an explanation for them.

From my study of this family of fishes I am inclined to believe that there is, in the eastern range of *Umbra pygmaea*, another form of these Mud Minnows, which may easily be recognized by its external characters. In form, structure and general habits, it doubtless does not depart from its near relative, *Umbra pygmaea*, while it does do so very markedly in its coloration.

This form—a sub-specific one—I believe has not been heretofore described, and I find it to present the following characters: General contour as in *Umbra pygmaea*, D. 14. A. 8. Dorsum olive brown, spotted and mottled with black; sides somewhat lighter; lower parts very light yellowish-olive; whitish, broken line extending from eye to base of tail. Running along immediately below this line is another of double the width, and of a deep olive or brown color. Sides more or less spotted with small spots of yellowish white; fins of a pale yellowish olive, without markings of any kind; an oblique whitish bar beneath either eye; chin pale yellowish white; eye black; a vertical white area at base of tail, bordered both in front and behind by black; borders of fins rounded. Other characters are those of the genus.

I propose for this new sub-species the name of *Umbra pygmaea bilineata*, in reference to the two longitudinal stripes

Aquatic Life

An international monthly magazine devoted to the study, care and breeding of native, exotic, gold and domesticated fishes, other animals and plants in the home aquarium and terrarium.

W. A. POYSER Editor
 JOSEPH E. BAUSMAN Publisher
 542 E. Girard Avenue, Philadelphia.

Entered as second-class matter, September 2, 1915, at the Post Office, Philadelphia, Pa., under Act of March 3, 1879.

Practical articles and notes on topics pertaining to the aquarium and terrarium are always wanted for AQUATIC LIFE. Readers of the magazine are invited to join in making it a medium of mutual help, and to contribute to it any ideas that may occur to them. The pages are always open for anyone who has anything helpful and practical to say. Manuscripts, books for review and general correspondence should be addressed to the editor.

AQUATIC LIFE has the largest circulation of any magazine in the world devoted to this branch of nature-study. It presents to advertisers a market that can be reached through no other medium. Rates made known on application.

Yearly Subscription\$1.00
 Foreign Subscriptions 1.35
 Single Copy10

Payments may be made by money order, draft or registered letter. Foreign remittances should be by international money order. If local checks are sent, ten cents should be added for collection charges.

Copyright 1917 by Joseph E. Bausman

Vol. II July, 1917 No. 11

running down either side, there being from twelve to fourteen in *U. pygmaea*, while the lateral markings in *Umbra limi* are vertical.

Aquarium Snails

The popular snail of today is the Copenhagen, Coral or Red Ramshorn, this last the better common name, properly *Planorbis corneus rubra*, of Europe. The demand for the species is not alone due to its brilliant red color, but because it is a good "worker," and excels the Japanese Snail, *Viviparus malleatus*,

which was formerly the dominant gasteropod in the aquarium. In activity it is only equaled by the American *Planorbis trivolvis*. These snails ravenously devour unconsumed fish food, vegetable matter, and especially the confervæ that develops on the sides of the aquarium. Both species can be easily propagated in an aquarium or tub, fishes being excluded, as they would devour the snails as hatched. The eggs, numbering twenty or more, are deposited in a round, gelatinous mass, attached to the plants or sides of the receptacle. The young will appear in about twenty to thirty days, according to the temperature. Food should be provided in the form of lettuce leaves or turnip tops. If the Red Snail and the native species are kept together they will interbreed, and much of the red color be lost. Figure 5 answers equally well for both species.

In the same family (*Limnaeidae*) with the foregoing are two other species, one a favorite, the other little used. The first is the sadly misnamed African snail, *Limnaca auricularia*. The common name, African, seems to be peculiar to the aquarists' world. Inasmuch as it is not from Africa, being a native of Europe, it is time to give it the proper common name, Ear Snail, the vernacular of the conchologist, and a translation of the scientific name. Why it should be called the Ear Snail is quite evident in the illustration, Figure 1. The spire of the shell is very short, while the body-whorl is large. The body and the shell are horn-color, the shell being attractively marked with a darker shade. This snail is quite an industrious feeder, but is short-lived. However, it is readily propagated like the Red Snail. The allied Niagara or Great Pond Snail, *L. stagnalis*, Figure 4, has an extremely long shell, which may reach a length of two inches, and is our largest fresh water species. It is com-

mon to both Europe and North America, though its range is restricted and it cannot always be found. In the aquarium it does not confine its appetite to the algæ, and will attack the higher plants. For this reason it should be provided with abundant food, such as the common floating plants, and but one or two specimens should be placed in a tank.

The Red Ramshorn, American Ramshorn, Ear and Niagara snails belong to the order PULMONATA, which includes

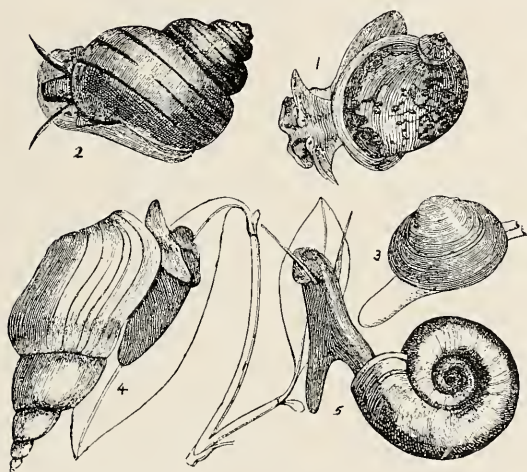

land and fresh water snails. All are provided with a lung chamber and are without gills, so it is necessary for them to occasionally rise to the surface of the water for air. The species described are hermaphrodites, both sexes being present in an individual.

The Potomac Snail, *Paludina contecta*, figure 2, and the Japanese snail are closely related. In fact, they will interbreed if placed together. The sexes are separate, and the males may be distinguished by the unequal size of the tentacles, the right one being shorter than the left. The eggs are hatched within the female, and the young retained for some time, being perfect snails about the size of a pea when expelled. For this reason it is possible to raise them in an

aquarium with fishes. The full-grown individuals spend much of the time in inactivity upon the bottom, and, being large, are of little use in keeping the plants free from algæ, the Ramshorns being particularly efficient for this work, due to their activity, small size and negligible weight. The Potomac and Japanese snails are provided with a gill, hence do not rise to the surface for air, have an operculum or horny plate by which the shell is closed when the animal retires within, and various other anatomical details which prove their affinity to certain marine snails.

Every aquarium should contain a small mussel or two. They can do little harm, and may accomplish much good. Figure 3 shows a tiny species, with the foot by which it moves and the inhalent and exhalent apertures extended. Through one aperture the water is drawn, the food of the mussel extracted, and then it is passed out through the other. Raking up the mud and plants in a pond or slow stream will usually reveal a few specimens.

Three kinds of Paradise Fishes are known to aquarists: the common form, a variety with reddish body and red stripes, and *Macropodus opercularis* having a caudal fin resembling *Haplochilus* or *Belonesox*—the most beautifully colored one.—*C. J. Heede.*

“He who buys had need to have a hundred eyes, but one is enough for him that sells the stuff.”—*Benjamin Franklin.*

We don't believe that an Allentown man saw a snake sixteen feet long. Probably a fishworm that somebody dropped on their way home from a day's angling in the Lehigh.

Society News

The June meeting of the Philadelphia Goldfish Fanciers' Society was held on the 20th, in Saull's Hall, 802 Girard avenue.

The competition was for novices—members who have not at any time received an award in competition. Judges, William Hartman, Dr. F. C. Leffman and R. L. Harding make the following awards:

Scaled Telescopes—Silver cup, Samuel W. Burgess; blue ribbon, William J. Hodges; red ribbon, Dr. Louis W. Rehbein; yellow ribbon, A. J. Hoag, Jr.

Scaleless Telescopes—Blue ribbon, James A. McDevitt; red ribbon, Samuel W. Burgess; yellow ribbon, Elmer E. Hazlett.

Scaled Japs—Blue and red ribbons, Dr. Louis W. Rehbein. A yellow ribbon was not awarded.

Scaleless Japs—Blue and red ribbons, Harry H. Mills; yellow ribbon, B. McQuade.

New members—F. S. Walton, John Krause and Paul R. Koehler.

A motion was passed at this meeting increasing the monthly dues to twenty cents. No meetings will be held during July and August.

FRED RICHARDSON, *Secretary*.

At the recent annual meeting of the Chicago Aquarium Society the following officers were elected for the ensuing year: *President*, Dr. H. G. Champlin; *vice president*, Miss Helen A. Loomis; *Secretary*, N. G. Hitchcock; *Treasurer*, Walter C. Schroeder; *Board of Governors*, W. H. Hitchcock, St. Elmo Linton, Austin N. Niblack and H. W. Keedy.

The members of the Reading Aquarium Society recently journeyed to Pricetown, some fourteen miles away, and

attacked a chicken dinner in full force. The menu comprised chicken, chicken, and still more chicken, and while the members are all temperate, none refused the famous Princeton mince pie.

Enthusiastic good fellowship prevailed. Each member wore a club button and "Old Glory," and attention was divided between singing patriotic songs, led by Mr. T. R. Wilson, and talking "fish." The members present included John W. Kershner, Ray C. Lash, Oscar A. Becker, G. R. Wilson, W. Scott Slegel, Theo H. Abelen, George S. Breneiser, W. H. Himmershitz, I. S. Yeager, Morris F. Kissinger, W. A. Barber and the writer. The dinner was such a success that it was decided to hold another at the same place next year.—S. O. MELLERT, SECRETARY.

The Milwaukee Aquarium Society held its annual meeting on Wednesday, June 6th, and elected the following officers for the coming year: *President*, Rev. Paul W. Roth; *Vice-President*, Dean Liborius Semmann; *Recording Secretary*, George Helsing; *Corresponding Secretary*, Arthur Simon; *Treasurer*, George J. C. Steffen; *Librarian*, Jacob Merget; *Custodian*, Alfred H. Schroeder; *Directors*, Ed. F. Kieckhefer and Rev. G. Keller Rubrecht.—ARTHUR SIMON, SECRETARY.

The Kensington Goldfish Society, Philadelphia, is rapidly forging ahead. Fanciers residing in this section of the Quaker City should get in touch with H. J. Mackrell, president, 2816 Jasper street, and become members.

The Aquarium Specialty Company, Joseph Taubles, manager, has moved to more commodious quarters at 414 East Tremont avenue, New York City.

"AQUARIA FISH"

A practical work on care and breeding of fish in the Aquarium, Greenhouse and outdoor Ponds. Finely illustrated. Every one interested in keeping fish should send for a copy of this book. Price, \$1.

Four-Horned Snails (*Ampullaria Gigas*) deposit a mass of large coral red eggs out of the water, the little snails drop into the water as they hatch. These snails are invaluable for destroying Hydra in the aquarium.

Thoroughbred Collie Pups, beautifully marked.

F. L. TAPPAN

Route 2, Hopkins, Minn.

GOLDFISH SPAWN

From Choice Telescopes & Japs, \$2 per 100 Eggs

I. X. L. Regular and Baby Fishfood, 10c. Box

W. E. WALP

1309 NORTH 55TH STREET PHILADELPHIA

LORQUINIA—The Naturalist's Monthly of the Southwest

Is published monthly by the Lorquin Natural History Club, and contains original observations of naturalists, particularly of the West. Associate membership, including subscription, \$1.50 per year.

LORQUIN NATURAL HISTORY CLUB,

1051 West 23rd Street, Los Angeles, Cal.

GEORGE'S GOLDFISH SHOP

Goldfish of All Varieties

George's Imperial Fish Food : 10c Postpaid

Dried Shrimp : : Box 10c, per pound 60c

Plants Aquaria All Supplies

N. W. 60th and De Lancey Street, Philadelphia

EDWARD S. SCHMID

Emporium of Pets

All Kinds of Goldfishes and Aquatic Plants
Water Lilies

712 Twelfth Street, N. W., Washington, D. C.

Taxidermy Send for Catalog

**BETTER CUTS AT
BETTER PRICES**
PROMPT SERVICE GUARANTEED
GOULD-WILHELM CO. INC.
ARTISTS * ENGRAVERS * PHOTOGRAPHERS
44 N. 4TH STREET PHILA.
SEND FOR SAMPLES AND PRICES THEY WILL INTEREST YOU

Otto Walter

86 Suydam Street :: Brooklyn, N. Y.

Near Evergreen Avenue L Station

Breeder and Importer of

TROPICAL & GOLDFISHES

Telescopes Calicos Japs Fan-tails

Dealer in All Varieties of Aquatic Plants

All Kinds of Fish Foods

Fresh and Dried Daphnia

AQUARIA, UTENSILS AND SUPPLIES

AQUARIUMS OF ARTISTIC DESIGNS

For home, conservatory and lawn. Beautiful and durable. Any size made to order.

FISHES PLANTS ALL SUPPLIES

We go anywhere to construct aquatic gardens. Write for illustrated price list.

PIONEER AQUARIUM CO., Racine, Wisconsin

ENCHYTRAE (White Worms)

The ideal live fish food which can be raised indoors all year round. Portion 50c (cash or money order) with instruction how to breed them

CHARLES E. JENNE

109 - 22d Street, West New York, N. J.

DRIED SHRIMP

The General Utility Food for Fishes.

Per pound, coarse, 75c.; fine ground, \$1.

St. George's Natural Fish Food, \$1.50 lb.

Sample can, 15c Add postage to your zone

CANADIAN BIRD STORE,

2139 West Van Buren Street, Chicago, Ill.

GEORGE A. SCHENK

Young Calico Japs and Telescopes

Good Quality as Low as \$3, \$4 and \$5 Dozen

A few Lionheads reasonably priced

I want YOU on my mailing list

29 Claremont Place

Mount Vernon, N. Y.

OSCAR LEITHOLF

433 Fourth Avenue - Pittsburgh, Pa.

TROPICAL FISHES

PLANTS :: SNAILS

Planorbis corneus Var. *rubra*

Paludina vivipara

Aquarium: 281 Southern Avenue

Write for Price List

HERMAN RABENAU, Aquarist

PERMANENT DISPLAY OF Aquatic Life & Terraria

must be seen to be appreciated
Visitors Welcome

Plants and Tropical Fish a Specialty
Importations of New Varieties received
regularly

1163 Myrtle Avenue, Brooklyn, N. Y.
Near Broadway.

Use Regenia Aquarium Salts

To replace the natural salts in your aquarium as absorbed by the fishes and snails. Excellent for plants. Help the snails form shell. Benefits the fish. **Box of Six Powders, 25c.** For sale at Pet Stock stores.

Violet-Ray Fish Remedy

Relieves Constipation, Fungus, Tail Rot, Congestion in fancy fishes; also white spots on Tropical fishes. **Box of Six Powders, 25c.** Safe and effective.

REGENIA CHEMICAL CO.

Station K.

Philadelphia

B - Ys!

(BE WISE) MEANING ALSO
"BEST - YET"

and adopt at once a "BEST-YET" Tropical Aquarium



which affords tropical conditions for Tropical Fishes.

Send for my free circular on this and "Best Yet" Fishfood, accessories and specialties.

"DOMESTICATED FISH"

The first and only illustrated book on tropical fish and Goldfish. Price \$2.60 (including payment on supplement). Without supplement, \$2.08.

New Importation of Brilliant Tropical Fishes

W. L. BRIND, Aquarist

449 W. 206th Street, New York

Phone before calling, St. Nicholas 8418

THE BRUCE FISHERIES

Breeder, Importer, Wholesale & Retail Dealer in

All Kinds of Goldfish

Comets a Specialty

ELGIN K. BRUCE, THORNBURG, IA.

FRANKLIN BARRETT

EVERYTHING COMPLETE FOR THE
AQUARIUM, POND AND LAKE

Wyoming Avenue, & C Street, Phila., Pa.

SEND FOR PRICE LISTS

THE TERMINAL PET SHOP

PETS OF EVERY DESCRIPTION AND KIND

Manufacturing and Maintenance of Aquariums a Specialty

All Kinds of Cat and Dog Foods and Medicines

HUDSON TERMINAL BUILDING

Concourse, New York

Fine Broad-tail Telescopes

BLACK & CALICO

Correspondence Solicited

GEORGE WILT, 1519 N. 62nd Street

PHILADELPHIA

Winners

My Broad-tail Telescope Goldfish were awarded firsts and three special prizes at the last annual exhibition of the Aquarium Society held in the American Museum of Natural History, New York. Young stock from these fine fish for sale during the coming season. Watch my future ads.

Otto Gneiding's Goldfish Hatchery

31-37 Depot Ave., Ridgefield Park, N. J.

EVERYTHING IS FISH THAT COMES TO THE NET OF A NATURALIST

Don't paddle in the water with one hand and be blind with both eyes. In other words "keep your eyes open" for all nature.

Our Magazine

The Guide to Nature

Will Help You

It is edited by EDWARD F. BIGELOW, who fishes in the heavens and earth, as well as the waters under the earth.

Four months' trial, 25c. One year, \$1.00

THE AGASSIA ASSOCIATION

ArcAdia

Sound Beach

Connecticut

New Aquarium Book

GOLDFISH VARIETIES AND TROPICAL AQUARIUM FISHES

By *Wm. T. Innes*

This work is endorsed by the U. S. Bureau of Fisheries and leading fanciers. It is thoroughly practical in every respect, and is written so plainly that a beginner may easily understand every point. 170 beautiful illustrations, mostly from life, including prize winning Goldfishes. 19 chapters. Gives alphabetical list of 300 aquarium fishes, their breeding, foods, temperatures and care in detail.

Sent anywhere upon receipt of Price \$3.00

Perfect Photograph of the Best Moor Goldfish

Life-size, Natural, Extremely Handsome Price 50c

We will enclose one of these prints with each copy of our new book, "Goldfish Varieties and Tropical Aquarium Fishes," where we send two or more books at retail to one address.

INNES & SONS, Publishers
129 - 135 N. 12th Street
Philadelphia

TEN VARIETIES OF BEAUTIFUL AQUARIUM PLANTS

for \$1.00 Postpaid

J. HENRI WAGNER, 1909 North Capitol
Washington, D. C.



What's the Object?

See you later!

AQUARIUM STOCK CO

150 Chambers Street :: New York City

Aquarium Specialists

GOLDFISH, FOODS, PLANTS, SNAILS, ETC.

Combination Natural Fish Food - Sample Can 10c
Imported Shrimp Fish Food - - Sample Can 15c
Imported Wafer Fish Food Large Sample Box 10c

Special Prices on Quantity Lots Cash With Order

Catalogue Sent Upon Request

Orders amounting \$2 delivered postpaid.

Mail orders promptly attended to.



DEALERS

Do you want a big seller that you can guarantee will give satisfaction and make friends for you?

**Our Aquarium
Vacuum Cleaner
Will Do the Trick**

List this article in your catalogues.

*Samples by Parcel
Post, 50c, 75c, \$1.00*

Liberal discounts to legitimate Dealers and Jobbers.

Mfg'd by

Acton Electric Co., Inc.

1133 BROADWAY

NEW YORK

Patents Pending

WALTER BELL

Breeder of Broad-tail Telescopes

BLUES BLACKS CALICOS

4324 WYALUSING AVENUE, PHILADELPHIA

Prices Reasonable

CARL LAZER

Dealer and Breeder of Tropical Fishes

Aquarium Plants Red Snails

All Kinds of Aquaria and Supplies

Open Evenings and Sunday

647 West 184th Street New York City, N. Y.

CRESCENT FISH FARM

Breeders and Collectors of

Goldfish and Other Aquarium Fishes

Alligators, Turtles, Chameleons, Snails, Water Plants

We are now booking orders for
Fall shipments of *Mollienisia*
latipinna, *Gambusia holbrooki*
and *paradise* Fish.

1624 Mandeville Street, New Orleans, La.

Michaelsen Bros

**GOLDFISH
BREEDERS
FLORISTS**

58th and Walnut Streets
110 South 52nd Street
Philadelphia

Aquarium Fishes

All Kinds of Aquatic Plants

Aquaria & Supplies

Wholesale and Retail

Nippon Goldfish Co

1749 Buchanan Street, San Francisco, Cal

Importers : and : Dealers

JAPANESE GOLDFISH

DIRECT FROM BREEDERS IN JAPAN



Awarded Gold and Silver Medals
Panama-Pacific International Exposition
San Francisco, 1915

ALL KINDS OF AQUARIA AND SUPPLIES

Price Lists Furnished to the Trade Only

HARRY P. PETERS

1210 N. Warnock Street, Philadelphia, Pa

BREEDER AND IMPORTER

Rare and Fancy Fish

Plants of every variety, Snails and
Aquarium Supplies of all kinds at all
times.

MANUFACTURER OF

Green River Fish Food

15c Box

Green River Baby Fish Food

20c Box

A GOOD FISH FOOD is one of the
most essential things necessary to
keep fish in good health. After the
test of years Green River stands out
as the best food on the market. It
keeps the fish in good color by pro-
moting a healthy, robust growth. It
will not sour or cloud the water. Ask
your dealer or send for it today.

Breeders

A large assortment of splendid Telescope
and Jap goldfish at reasonable prices.

Fine Assortment of Lionheads

Shipping Cans, 45 Cents.

Young Blues, Blacks & Calicos \$1.50 Doz

Young Veiltails or Broadtails \$5.00 Doz

HARRY P. PETERS

1210 N. WARNOCK STREET
PHILADELPHIA

GREEN RIVER FISH FOOD

Due to the constant increase in
costs of ingredients, boxes and print-
ing, it has become necessary to in-
crease the price of these foods to 15
and 20 cents. When conditions again
become normal the old prices will
again prevail.

HARRY P. PETERS,

1210 North Warnock Street,
Philadelphia, Pa.

50,938

August, 1917

10¢ Copy

Aquatic Life



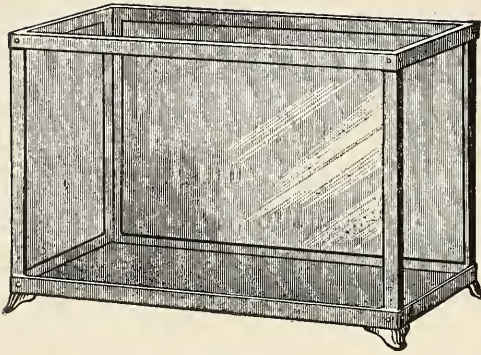

Jacob C. Cassel

915 Arch Street, Philadelphia, Pa

Manufacturer of

AQUARIUMS

Aquarium Ornaments

Floral Terra Cotta, Etc.

Goldfish Fish Globes Fish Food

and all aquarium requisites.

Send for Catalog.

Aquarium Specialty Co. 414 E. TREMONT AVENUE NEW YORK CITY

Fine stock of all breeds of gold fish the year round,
Under present conditions we still succeed in showing an unusual good variety of
tropical fishes, and imports are coming in quite frequently.
We specialize in aquatic plants and snails.

REVISED STOCK LIST OF AQUARIA OF OUR MAKE.

Galvanized Metal Frame, Enameled, Glass or Slate Bottom

No.	Dimensions	Plain	On Legs
No. 1.	11x 7x 7	\$1.35	\$1.65
" 2.	14x 9x 9	1.75	2.15
" 3.	17x11x11	2.50	3.00
" 4.	20x13x13	3.30	4.00
" 5.	24x12x14	5.25	6.00

Solid Brass Frame, Projecting Slate Bottom, or on Legs.

No. 1.	12x 6x 8— 2½ gal.	\$3.00
" 2.	14x 8x10— 5 gal.	4.00
" 3.	16x10x12— 9 gal.	5.50
" 4.	18x12x14—14 gal.	7.00

GLASSWARE.

Dip-Tubes, Automatic Syphons, Ther-
mometers, Feeding-Rings, Dip-Nets for
all purposes.
From 15c. up and \$1.20 per dozen

Steel Angle Frame, Heavy Plate Glass, Slate Bottom.

No. 3½.	24x14x14— 22 gal.	\$8.00
" 4½.	30x16x16— 36 gal.	12.50
" 5½.	36x18x18— 54 gal.	20.00
" 6½.	42x20x20— 80 gal.	35.00
" 7½.	48x22x22—110 gal.	60.00
" 8½.	54x24x24—145 gal.	95.00
" 9½.	60x26x26—180 gal.	135.00

Any size or shape made to order.

FISH FOODS.

	Per Pkg.	Per Lb.
Natural Fish Food	\$0.10	\$0.60
Universal Fish Food	.15	2.00
Ground Dried Shrimp	.10	.60
Ground Dried Flies, etc.	.15	2.00
Ground Dried Daphne	.20	3.00
Infusoria Creating Food	.15	2.00

Correspondence Solicited. JOSEPH TAUBLES, Manager. No Catalogues

A B C Aquarium Nets and A B C Glass Scrapers

These nets are scientifically designed and
carefully constructed of the finest materials.
The netting is soft and durable and the
frames of non-rusting wire:

- No. 1. 1½x2½ in., for baby fish.
 - No. 2. 3x4 in., for tropical fish.
 - No. 3. 4 in., round, for gold fish, etc.
- Sample of any by mail, 20c.

For removing dirt and vegetable growths
from the glass sides of aquaria, the A. B. C.
Glass Scraper is unexcelled. It has 12-inch
handle and a well-sharpened scraping edge.

The A. B. C. Scraper is well made
throughout and with ordinary care will
last a long time.

Sample by mail, 25c.

Special low prices on dozen and gross lots

Live dealers can make splendid profits handling the A B C Line

A B C SUPPLY CO. 1505 St. Nicholas Avenue, New York City, N. Y.

MUSEUM AQUARIA

EDGAR R. WAITE, F. L. S.
Director, South Australian Museum

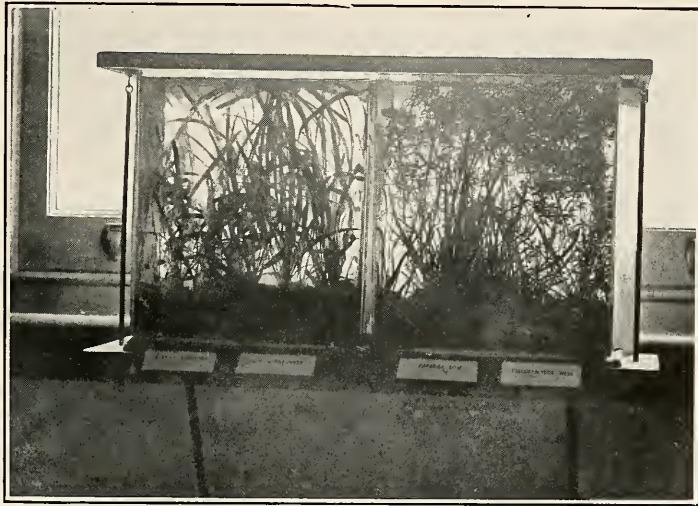

When I came to Adelaide three years ago, one of my first unofficial moves was to take steps to inaugurate an aquarium in the Zoological Gardens, but the outbreak of the war put an end to the project, at any rate for the time being.

Having been an aquarist for many years, I therefore next turned my attention to introducing "parlor aquaria" in the museum itself, and having obtained the necessary authority, I installed twenty large electric accumulator jars. Ten windows were available, and below each sill a neat baseboard was bolted to the wall. To place two jars side by side on a carpet of felt was a simple matter, but something more than this is required in a

public institution.

In aquaria houses built for the purpose, the vessels are quite shut off from visitors, but in a museum, where the glasses are as available as at our own homes, some arrangement must be made to prevent kindly-disposed people from feeding the occupants with biscuit, lollies, matches or tobacco. A statement as to how this was managed may be of service to others similarly situated, and perhaps not unwelcome to some private owners who find it difficult to say "please don't touch."

A light picture frame was made long enough to just slip over the two vessels placed side by side, but three inches more

from back to front than either of them; this was glazed with opal glass to exclude excess of light, dust and fingers. A small cup-hook was put into the lower side of the frame at each end and, vertically below each hook, a $\frac{3}{8}$ -inch hole was bored through the base board. A small screw-eye was next soldered into

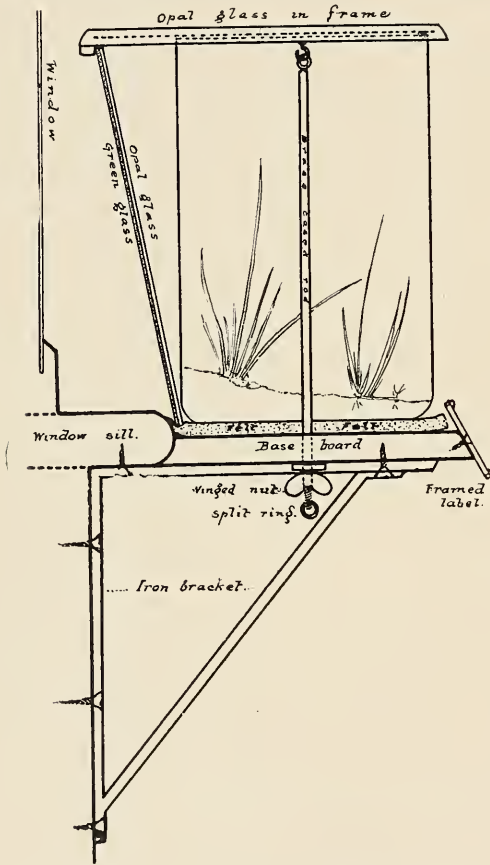

one end of a $\frac{1}{4}$ -inch brass-cased rod, this was passed through the hole in the board, hung on the cup-hook and cut off $\frac{3}{4}$ inch below the board; it was tapped for 1 inch and fitted with a thumbscrew; the end was drilled and a split ring fitted. Two such rods were, of course prepared for each set.

As window blinds are furnished for the Museum, and not for the aquaria, it became necessary to shield the latter

from the light of sunny Australia. This was done by means of two sheets of glass, one opalized to diffuse the light and confine attention to the inmates instead of permitting inspection of the view outside the window, and the other of green color to be used when direct sunlight fell upon the aquaria. These sheets rested upon the felt on the base-board and were inclined backwards above, being caught by a fillet on the underside of the frame, which it will be remembered is three inches wider than the accumulator jars. Ample air space is thus insured between the glass sheets and the wall of the aquarium, a provision made to counteract the heating rays of the sun coming through the window.

To feed the inmates or clean the vessels, the attendant gives the thumbscrews two or three turns and unhooks the rods from the frame; the rods drop to the baseboard, but cannot fall to the ground, owing to the size of the screw-eyes. As the frame is lifted the vertical sheets of glass are allowed to rest against the window pane, and are replaced against the fillet when the operation is finished.

The photograph shows the arrangement as seen from the front. Two labels are placed beneath each vessel, one giving the name of the plant and the other that of the animal occupant. The sketch illustrates the fittings as seen from one end.

Diseases are not the only thing that are contagious. Courage is contagious. Kindness is contagious. Manly integrity is contagious. All positive virtues with red blood in their veins are contagious.—*Henry Van Dyke.*

It were happy if we studied nature more in natural things; and acted according to nature, whose rules are few, plain and most reasonable.—*William Penn.*



The Florida Gopher Frog

DR. R. W. SHUFELDT, C. M. Z. S.



Figure 1. Gopher Frog (*Rana oesopus*). Natural size, from life

This curious American frog was originally described by Professor Cope and named *Rana oesopus*, receiving its vernacular name of Gopher frog from the habit it has of hiding in holes of the gopher tortoise, after the breeding season is over, at which time it is of solitary disposition. In its range it appears to be restricted to the peninsula of Florida, having, up to recent time, been collected only at Micanopy, Clarcona, Orlando, Ozona, and Lake Jessup; as a matter of fact it is rather rare in collections. It

undoubtedly occurs in numerous other localities, however; for, during the month of March, 1917, Mr. Nelson R. Wood, of the U. S. National Museum, collected a fine specimen at Auburndale, Florida, and sent it north alive. This individual was in my possession for a few hours, during which time I made three or four negatives of it; three of these have been reproduced to illustrate the present account (Figures 1-3).

One of the peculiar characters of this batrachian are the several dark brown

spots on the irides of the eyes; they are very striking, and at once command our attention. The animal may grow to be some four inches in length, and it is a known fact that the female is larger than the male. Some of the books give other measurements very fully, and its topographical anatomy has likewise been touched upon by authors. Individuals

ish shade, or even grayish or light purplish. Dorsally, the warts are yellowish, and the lateral folds brilliant orange, while much dark speckling is seen on this part of the body, as well as on the lips, the jaws being unusually massive. The dark tympanum upon either side has a light-colored spot occupying its centre. Limbs barred with dark brown transversely, five of these being very conspicuous on the legs.

Taken altogether, it is a most striking species with respect to its appearance, and certainly a very peculiar one in regard to its habits. So well is this all shown in the figures that any further description here would consume space to no end. It is readily distinguished from other species of our frogs, as from *R. arcolata*, and still more so from *R. pipiens* or *R. palustris*.

At either shoulder the Gopher frog has a large vocal pouch, capable of inflation to a marked degree. These pouches are found only in the male, and they give a most unusual appearance when fully inflated.

Gopher frogs are very clever at hiding, and when doing so they change color at will, assuming a whitish tinge, or brown, or deep purple, to intense black. Sometimes, when handled, the animal secretes from the skin a peculiar secretion, which has by no means a pleasant odor.

Mary C. Dickerson, a great authority on our batricians, has pointed out in her "Frog Book" that this "frog is so wary and has such strong habits of hiding, that but few specimens have come to light. The wariness of this species has resulted in a habit of spasmodic instead of continuous activity. Its method, like that of the cricket grasshopper, is ludicrous to observe. It remains absolutely quiet for minutes at a time, relying on its protective coloration, until the danger is well-nigh upon it. When the movement comes,

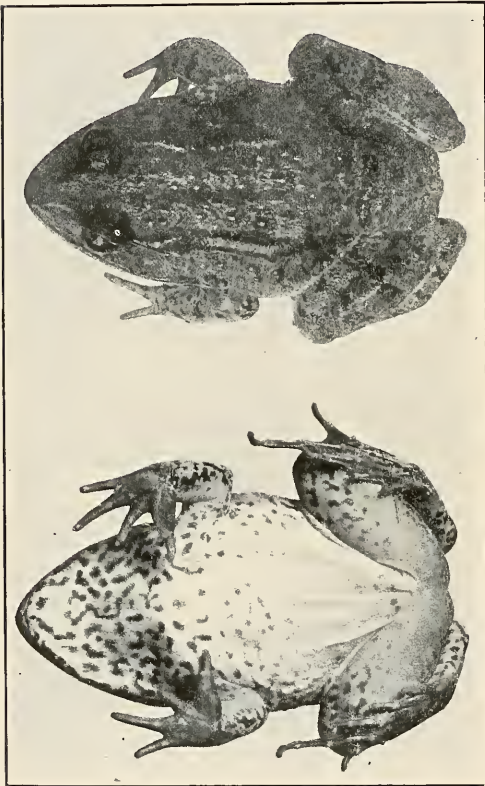

Figure 2 and 3. Dorsal and ventral views of the same specimen shown in Figure 1
From Life

vary in their general coloration, some being of a light, others of a dark brown. Beneath, it is glistening white, the throat and hind limbs being shaded with pale gray, the former beautifully speckled with spots of various forms; these occur also on the limbs, while but few are found elsewhere. Specimens have been taken having the upper parts of a yellow-

it is with startling suddenness and dispatch, leaving the frog statuesque again and observant, but in a new place" (p. 195).

The specimen Mr. Wood collected appeared to be quite at home in the water, and when left alone in an aquarium jar for the night, he was seen in the morning to be squatting down among some dark-colored stones in a peculiar attitude; he had assumed an almost entirely deep black color that was quite protective.

Gopher frogs feed upon small birds and insects, but most commonly upon toads, the last giving them no end of discomfort on account of the acrid secretion from their parotid glands. Indeed, after a meal upon a big toad, this frog has been observed to go through a series of somewhat extraordinary spasmodic movements, frantically trying to clear its mouth with its fore feet of the semi-poisonous juice the batracian he had endeavored to swallow had squirted into it.

So big is the mouth of this Gopher frog that it can manage to swallow a full-grown specimen of our common toad—a feat, however, that it in no way appears to enjoy. There is much to be learned about this species yet, and specimens will be welcome from any one living in those parts of Florida where it is found.

A stingy angler was fishing on a Scottish loch on a drenching day. He had been consoling himself from his flask and forgetting his gillie. Presently he asked the man if there was a dry place on the boat on which to strike a match.

"You might try my throat," said the gillie; "it's dry enough."

The rearing of carp is a very ancient practice; a treatise on the subject was written by a Chinaman during the third century.

Notes on the Diatoms

ANNA K. BEWLEY

The diatoms are among the most interesting and fascinating subjects that may be studied with the compound microscope. They can well be termed ubiquitous, because they are present in all waters, fresh and salt, from pole to pole. Naturalists formerly classed the diatoms as animals in consequence of their power of movement, but further study with the aid of improved microscopes, and confirmed by chemical research, resulted in a transfer to the vegetable kingdom.

The plant consists of a silicious envelope in three parts joined together somewhat after the manner of the old-fashioned cardboard pillbox—top and bottom caps held together by a ring. They are of every conceivable shape, but all are microscopic in size. Their great beauty consists in the marking or sculpture of the envelope. Almost every imaginable geometric design is imitated, and the resemblance is sometimes indicated by the name: *Heliopelta*, the sun-shield; *Arachnoidiscus*, like a spider's web. The markings on the valves of some species are not by any means easily discerned, even with the highest magnification and careful manipulation of the microscope. *Pleurosigma*, a favorite species to test the power of an instrument, appears, when magnified 500 diameters, to be marked by parallel lines (90,000 would measure but an inch across), but when magnified 2800 diameters the design is found to be reticulated resembling bobinette. The species of salt water are usually larger than those of fresh water.

Little is known in regard to the importance of the diatoms as food for young fishes, though they have been found in their stomachs, but they form the food of oysters and other molluscs, and have been found in the gizzards of

fish-eating birds and in guano. Dr. Carpenter considers that the diatoms are an important factor in maintaining the equilibrium of life in the South Polar Ocean, "since there is a marked deficiency in this region of the higher forms of vegetation, were it not for them there would be neither food for aquatic animals, nor (if it were possible for these to maintain themselves by preying on one another) could the ocean be purified of the carbonic acid which animal respiration and decomposition would be continually imparting to it."

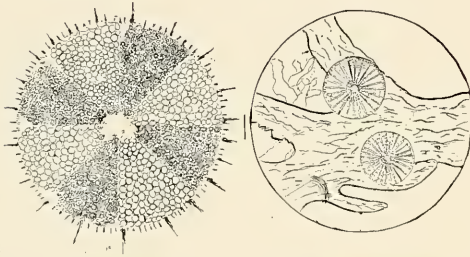

Heliopelta

Arachnoidiscus

Drawings by Author

The diatoms play a not inconsiderable part in the economy of mankind as they form a component part of metal polishes that are abrasive in action. Quite a number of much-used tooth and metal polishes contain them. I have a slide of freshwater forms taken from "Silver Suds" polishing powder, which was prepared by Mr. Frank J. Keeley. The well-known "turkey-stone," so much used for sharpening edged tools, is composed of the remains of diatoms. Throughout the world there are numerous almost pure fossil deposits, often of considerable extent. Richmond, Virginia, is underlaid by a stratum of diatoms, in some places lying fifty feet below the surface. Such deposits were formed while the locality was under water, and similar ones are being formed today. It is from such fossil formations that the material is taken for commercial purposes, provided

it be pure and not contain other matter difficult to separate.

The fresh-water species may be collected in springs and roadside ditches, appearing as dark amber patches. Almost pure collections can be made with a pipette, and may be seen to glisten in the sunlight. They will grow almost indefinitely in small vessels, which may be termed "micro-aquaria," and will be a continual source of delight to those having a microscope with which to study them.

In all scientific research, while specialization in some one line is to be encouraged, and is indeed necessary, in order to reach a point where one's work is of real value, yet we should build on a broad foundation, by acquiring a good general knowledge of scientific subjects, for by so doing we are better able to wrestle with the problems we are sure to meet.—*E. E. Hadley in Lorquinia.*

None but the well-bred man knows how to confess a fault, or acknowledge himself in error.

"Why does the Professor have all those letters tacked on to his name?"

"That shows he got there by degrees."
—*Exchange.*

AQUATIC LIFE has proven very attractive and helpful. It would seem almost a sacrilege to criticise it.—*ALRICH BURMEISTER, Manager, Pacific Goldfish Company.*

I am inclosing one dollar for renewal of my subscription to AQUATIC LIFE. In your last number I found an article that was worth more to me than the cost of the year's subscription.—*JOHN C. WHITE, Alabama.*



Polycentrus Schomburgki

WALTER LANNOY BRIND, F. Z. S.

Polycentrus schomburgki, or "King Cascarob," as it is called by the natives of Trinidad, British West Indies, is one of my earliest favorites among the essentially tropical fishes, as I procured a pair in the spring of 1910. The aquarist from whom I secured them gave me the most minute instructions on how to breed them. It was necessary to provide a suitable home, and as a uniform temperature of about 80 degrees Fahrenheit was needed, I had my first tropical aquarium built. This provided the exact conditions prevalent in the tropics, namely, warm water and atmosphere above it, and deep, rich soil for the plants, which insured a splendid growth.

The pair soon showed their pronounced approval of my efforts, for they at once entered into possession of the "palace," which was a six-inch flower pot laid upon its side, with the entrance facing sidewise to the east; the aquarium faced south. The maneuvers of the fish were comical. The male began by adopting an intense blue-black color, with white spots in diagonal rows on the sides. His eyes gleamed like live coals. The entire fish was a scant two inches long, and was full-grown. The female was light pinkish brown, with a decided salmon-tinted patch on the abdomen, indicative of ripe spawn. The male swam about her in a most amusing manner, sometimes backwards, then sideways, again with his body at an angle, but all the while watching her closely with fiery eyes. Finally he retired within the flower pot, swimming backwards until he was entirely out of sight. Soon

after the display of the fascinations of the male, the female decided to investigate the pot, and followed him cautiously. The inspection being satisfactory, the eggs were deposited on the ceiling of the pot, to which they adhered closely. This accomplished, the male chased his mate into the farthest corner of the tank, and

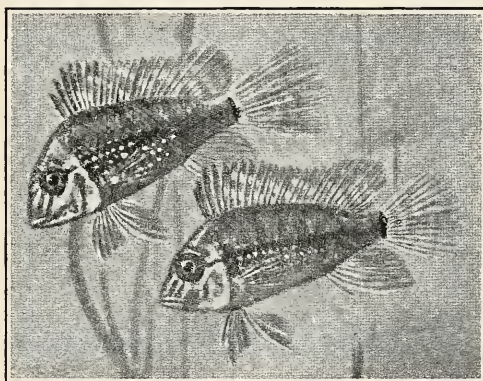

Polycentrus schomburgki

made her "stay put." At this time I removed her to another tank, otherwise, unless prevented by the male, she would have eagerly devoured the eggs.

From the moment the eggs were deposited, and until they hatched, three days later, the male assiduously fanned them with his fins, sending a constant stream of soft, warm water among them. As soon as hatched the little fish literally hung to the leaves of the plants. A few days later, having developed sufficiently, they detached themselves and chased infusorians, later devouring tiny *Daphne*. As soon as they had grown sufficiently to resemble their parents, the male was moved to his mate in the other aquarium.

(*Polycentrus*, many spines; *schomburgki*, in honor of Schomburgk.)

Carp Culture in Japan

We are pleased to submit the following information from the Imperial Fisheries Bureau, Tokyo, Japan, on carp culture, which we believe will be of interest to the many readers of "Aquatic Life":

The propagation of carp, *Cyprinus carpio*, has been practiced from ancient times, and the business is at present established in nearly all parts of Japan, but the most important districts are the warmer parts of Nagano, Gifu, Aichi and Shizuoka. German carp was first introduced in 1904, and the fry have been distributed among the districts, but so far this species is not welcomed in the market. The fish are raised in all parts in freshwater bodies, ranging from large lakes having an area of several hundred thousand acres down to swamps, moats, marshes, ponds, open sewages and rice fields of even several square yards. The water-depth is generally three to four feet, and standing water and streams are equally suitable. In the mountainous regions, such as Nagano, Gifu, Yamana-shi and Yamagata, running water is used for the ponds or moats.

Two methods of propagation are practiced, the "natural" and the "contracted" plans. In the former the seed fish, or fry, are liberated in natural lakes. This is practiced in the lakes of Biwa, Kasumigaura and Kitaura. Since 1908 eight million young carp have been freed in Lake Biwa. The Ibaragi Fishery Experimental Station has a plan to hereafter place two million fish a year in Lakes Kasumigaura and Kitaura.

In the contracted or compact plan, the waters are of small area, such as artificial ponds, moats and rice-field ditches. The system naturally divides into three periods, known as first, second and third-year growing. During the first year the chief objective is to raise seed-fish or fry. From a pond of a thousand tsubo (about

one and one-half acres), 240,000 fish, weighing a momme (3.7 grams), or 5400 or 10 momme (37 grams) each, can be harvested. In the second year five to six fish are raised per tsubo (six square feet) of pond, and should weigh a pound and a quarter at the end of the period. In the final period two or three fish, weighing two and one-half pounds each, are yielded per tsubo.

When rice-fields are used the fry are liberated in the spring, when the rice is planted in the watered field, and caught at harvest time in autumn. The fish are fed on silkworms, rice bran, rice flour, wheat flour, bean cake and various other vegetables.—ALVIN BURMEISTER, *Manager, Pacific Goldfish Company.*

The true naturalist is not limited to any one branch of nature-study. Though he may make a specialty of some particular branch, if he follows it closely and persistently, he will find that he must inform himself on some other line closely connected with it, in order that he may better understand the one of his choice.

I have received a lot of replies and orders for Enchytræ worms and recently made a shipment to England, all resulting from my advertisements in *Aquatic Life*.—Charles E. Jenne.

I inclose one dollar to renew my subscription to AQUATIC LIFE. It sure has life, gives life and saves lives.—N. OLGER HELGESEN.

In the United States alone, the Carp family numbers upwards of two hundred species.

The whole scheme of things, both in nature and man creations is efficiency, and its reward is certain.



Vallisneria Spiralis

C. J. HEEDE

The subject of this article, *Vallisneria spiralis*, the Tape or Eel-grass, is well known to most aquarists. It ranks a close second to the species of *Sagittaria* in popularity, though it is not inferior as an oxygenator, and is particularly useful in self-sustaining aquaria. The generic name, *Vallisneria*, was given by Carolus Linneaus, the father of botany, in his SPECIES PLANTARUM, 1753, and was in honor of Antonio Vallisneri, an Italian naturalist who wrote on plants and insects during the eighteenth century. The specific name, *spiralis*, refers to the habit of the stalk bearing the female flower.

The species is dioecious, which means that the sexes are distinct, an individual bearing either male or female flowers, but not both. The female or pistillate flower has its origin in the rootstock, and is born to the surface on a long, slender, spiral stalk. Here it meets the male flower, which had become detached from its short stalk at the base of the staminate plant, and pollination is effected. The stalk of the pistillate flower recoils and the seeds ripen below the surface. This method of sexual reproduction is rather uncertain, and is supplemented by multiplication by stolons or runners from the rootstock, from the terminal of which develops a new plant asexually. Several plants may often be found attached in this manner. The leaves are ribbon-like, even in width throughout their length, the tip abruptly rounded, and brilliant green. The leaf-cells have long been a favorite object, with microscopists to demonstrate the movement of the protoplasmic contents, and the tendency of the chloro-

plasts (the grains of green coloring matter) to arrange themselves toward the strongest light.

In the United States *Vallisneria* is widely distributed in ponds and slow streams from the Mississippi Valley eastward. Our native plants, though presenting no botanical distinctions, dif-

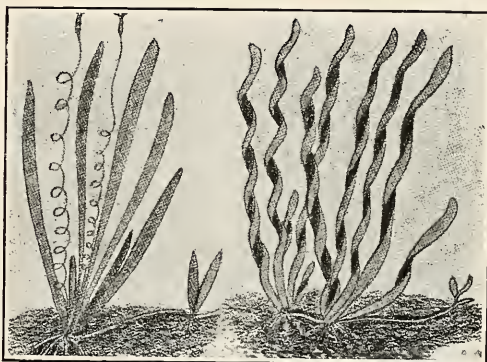

Typical *Vallisneria spiralis* (female plant) and the Form With Tortuous Leaves

fer in aspect and habits from the more desirable European form. They are broad-leaved, coarser, and do not thrive throughout the year and multiply in the aquarium. The European, or, as it is sometimes called, the Italian *Vallisneria*, has been known so long to American aquarists that the native plant is seldom used. As far back as 1902, Eugene Smith, in his book, THE HOME AQUARIUM, remarks that it is to be preferred to the native form, and adds that it seems to be represented here by male plants only.

A foreign publication has reported a form with tortuous leaves that is said to thrive in aquaria and maintain its characteristics. The statement is made that

it was collected in California, which is undoubtedly an error, as the species does not range west of the Mississippi Valley. To make certain that this range was correct, Mr. T. F. Brady, a California aquarist, ascertained from Prof. H. M. Hall, University of California, that the species was not known to occur within the State, nor beyond the limit given.

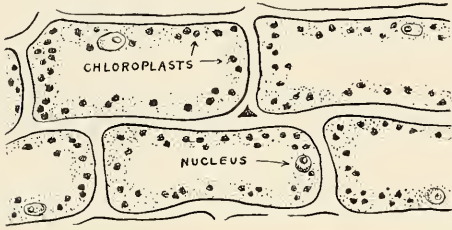

Cells from leaf of *Vallisneria spiralis* (greatly enlarged) showing chloroplasts the green coloring matter

To grow sturdy, bright green plants, the bottom of the tank should be quite rich. Though it will do well in sand alone in an old tank with the bottom enriched by the droppings of the fishes, it is usually advisable to use some sort of fertilizer. Leaf mould mixed with the sand is preferable. In changing plants from one aquarium to another it is well to have the water in both receptacles of the same temperature. The roots should be well spread and deep planting avoided.

A study of microscopic animal life—specimens from the aquaria of members—was the feature of the meeting of The Aquatic Association of Maryland held on the evening of July 11, in the Lexington Building Annex, Baltimore.

The members were "tipped off" in advance, and when the meeting began there were jars and bottles in great variety on hand, each holding prized specimens to be scrutinized through the microscope. *Daphnia*, *Cyclops*, larvæ of mosquitoes, eggs of fishes, frogs and snails, all passed parade-like beneath the lens. Some of the embryonic snails could be seen doing gymnastic stunts. A glance through the

"barrel" was sufficient to convince one that the time for "swearing off" had arrived.

The Association, though still in its infancy, has made wonderful strides in membership. Five new members were enrolled at the meeting, and the names of two women fish fanciers, Mrs. H. A. Altpeter and Mrs. F. F. Schneider, were added to the list—the first women to become members. President Cassell read letters of acceptance from Professor Caswell Grave, Department of Biology John Hopkins University, Dr. Hugh M. Smith, Commissioner, H. F. Moore, Deputy Commissioner and Henry O'Malley, Fish Culturist, United States Bureau of Fisheries, all having been elected honorary members. These gentlemen, all of whom occupy enviable niches in the world of science, expressed sincere interest and promised hearty co-operation.—P. C. CHAMBLISS, *Secretary*.

The Essex County Aquarium Society, Newark, N. J., will hold its second annual exhibition from September 13th to 16th inclusive. The Newark Public Library, Broad and Washington streets, has kindly consented to have the exhibition staged in the library building, and has promised very desirable space.

The show will be competitive and is open to anyone. Five silver cups are offered as prizes, together with the usual first, second and third ribbons. A large silver cup will be awarded to the society having the largest entry. Information and entry blanks will be furnished upon application by the secretary of the Exhibition Committee.

Entries are invited from the aquarists of Philadelphia, Brooklyn, and from other points from which the transportation expense will not be great. The first public exhibition given by the society lasted but a day, and was non-competitive, yet was exceptionally successful. A large number of fishes were shown and it was well attended.—H. I. HARTSHORN, *Secretary, Exhibition Committee, 12 Myrtle avenue, Newark, N. J.*



Danio Analipunctatus

ERNEST LEITHOLF

Clean cut, attractively colored, lively and well disposed towards other inhabitants of an aquarium, *Danio analipunctatus*, a native of Rangoon, India, is rapidly equalling the more familiar *Danio rerio* in popularity. Both sexes are alike in the distribution of the colors. The back is olive; sides with a silvery lateral stripe suffused with orange and bordered above and below with blue lines, the lower one somewhat broader and iridescent. The lines are carried faintly through the caudal fin. Abdomen silvery, with a row of blue spots that terminate in a cluster at the base of the anal fin, which is spotted, and from which the species derives the specific name *analipunctatus*, meaning "spotted anal." Ventral, anal and dorsal fins edged with grayish white, the first two faintly spotted; pectorals colorless.

This species makes no particular demands as far as maintenance is concerned. When short of space I have used aquaria holding less than a gallon, and they seemed content and proceeded to spawn. A large, well-planted tank is, of course, to be preferred. Neither are they exacting in the matter of foods, as they will readily partake of the usual prepared kinds. To insure virile spawn, and when even obtainable, Daphne, larvæ of mosquitoes, and other live foods should be furnished.

Spawning occurs every two or three days for a period of several weeks, and, after a rest interval of a week or two, will happen again and so on throughout the greater part of the summer. Though smaller than the other species of the

genus, its eggs are the largest, and for this reason it is not as prolific in so far as the number of eggs in a single delivery are concerned. While courting the fish are exceedingly active, and playfully chase each other incessantly, but do not indulge in fin-mauling, to which many fishes are addicted. While forcing her

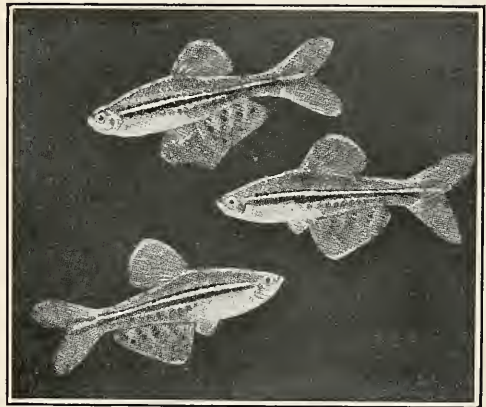

Danio analipunctatus

way through the dense growth of plants, the female expels or "sprays" the non-adhesive eggs, which may number from several to a dozen or more. The male manages to "do his bit" by being near his mate to fertilize the eggs before they reach the bottom. The orgasm is repeated several times during the day. The eggs will hatch thirty-six hours to four days later, according to the temperature, which should be about 75 degrees Fahrenheit. Unable to swim freely for a day or two, the young hang upon the plants and sides of the tank. From this time, and until large enough to eat tiny Daphne, they need an abundant supply of microscopic life.

It is possible to raise a few youngsters in a densely planted aquarium with the parents, but if reasonable numbers are desired, either the parents or the eggs must be removed to another vessel. Or the eggs may be saved by using a frame of glass rods or tubes made to fit the tank snugly, the rods a sufficient distance

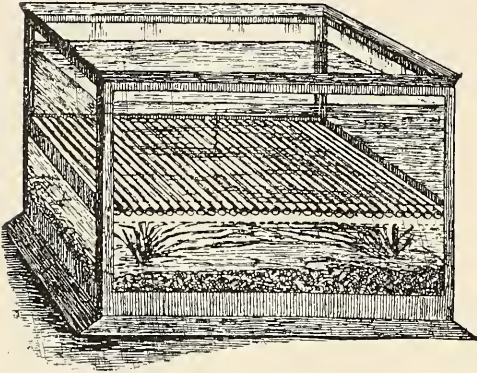

Spawning Tank for Danio
Showing Frame in Position

apart to permit the eggs to pass between. No crevices between the frame and the sides of the tank should exist, as the fish might manage to make their way to the "forbidden ground" below. When spawn is observed upon the bottom, the frame should be taken out and the eggs removed to a hatching vessel, using a dip-tube to gather them.

The sense of pain is very feeble among fishes. A trout has been known to bite at its own eye, placed on a hook. Similar insensibility has been noted in the pike and other fishes.—*Jordan*.

Christy.—"The alligator can go six months without eating."

Long Locks.—"Just the pet for a poet."

Keep thy shop open and advertise in *Aquatic Life*, and thy shop will keep thee.

Geophagus Jurupari

ERNEST LEITHOLF

Like the other species of the genus known to the aquarian, *Geophagus jurupari* comes from South America, and is found in the pools and small lakes of the Amazon region. The fish seems to have been confusing to the ichthyologists. Schomburgk classified it as *Geophagus bucostictus*, Gunther called it *Scatoperca leucosticta*, while others have thought it identical with *Geophagus surinamensis*. The natives call it Juru-pari Pinda, meaning "Devil's Angle."

Mandee, in his Year Book for 1911, describes it and assumes that its habits are similar to those of the others of the

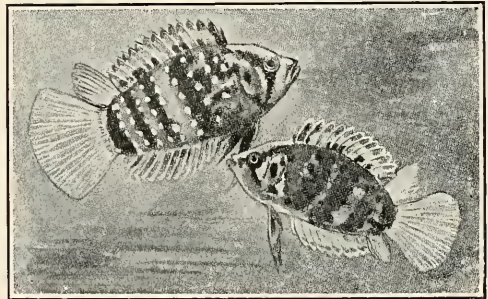

Geophagus jurupari

genus. Apparently it had not been bred in captivity up to that time, and indeed I have not been able to find any reference to its habits in more recent works. That analogy is dangerous will become apparent in my next paragraph. The fish lacks attractive colors, and has the vicious temperament of its relatives, hence is not apt to enjoy a great degree of popularity. Its breeding habits are decidedly peculiar, however, and for this reason it is well worth observation.

Give this *Geophagus* a roomy aquarium, several inches of sand, a flat stone or two, and the proper warmth, about 75 degrees Fahrenheit, and its fancy is very apt to turn to thoughts of love. This being consummated, its peculiar habits

will become apparent. A convenient stone will be selected, and beneath it, from end to end, a tunnel will be dug. Here the eggs will soon be deposited. When the young appear the parents guard them and lead them about the aquarium after the manner of the cichlids. A hasty approach, or any action deemed hostile will cause the parents and brood to hastily retreat into their covered trench, there to await the passing of the danger, though in the meantime one of the adults will appear at the opposite opening, apparently ready and eager to charge any possible foe.

Mr. Robert J. Macrory, of the Pittsburgh Aquarium Society, is the only aquarist, to the best of my knowledge, who has succeeded in spawning this species, and it was his pair that I observed as described. Unfortunately none of the young survived to maturity. The stone under which the tunnel was dug measured fully five inches in diameter.

Smoked Dogfish

Experiments in smoking various species of fresh-water fish, begun at the Fairport, Mich., station of the United States Bureau of Fisheries about two years ago, have yielded interesting results.

The bowfin, or grindle, which usually is regarded as practically worthless, has been found to yield a very superior product when properly smoked. All who have eaten samples have spoken of the excellent texture and flavor of the meat, and some have pronounced it the best of smoked fish.

Further experiments are being made with a view to obtaining a product which will appeal to the trade in appearance and quality.

The bowfin is generally known through the Mississippi Basin as dogfish,

and has been regarded as practically worthless. It is abundant in the Great Lakes and in sluggish waters from Minnesota and New York to Florida and Texas.

The proper utilization of this species will not only add another commercial product to the market, but also will tend to reduce the relative abundance of a species which is most predacious upon the other fishes that are more highly valued in the fresh state.

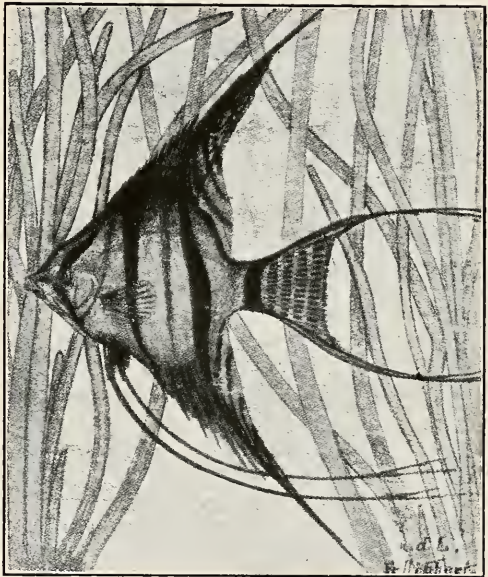

Pterophyllum scalare

Paullin's *Pterophyllum scalare* have spawned again! This is not a startling announcement because it has happened a number of times, but very few aquarists have been privileged to witness the operation. It is doubtful if less excitement attends the function in any other species. Utterly oblivious to several pairs of eyes "glued to the glass," the pair proceeded. Other than the somewhat methodical movements of the fish, little out of the ordinary would have been apparent to the average man. A broad, curved leaf of *Sagittaria* had been se-

Aquatic Life

An international monthly magazine devoted to the study, care and breeding of native, exotic, gold and domesticated fishes, other animals and plants in the home aquarium and terrarium.

W. A. POYSER Editor
 JOSEPH E. BAUSMAN Publisher
 542 E. Girard Avenue, Philadelphia.

Entered as second-class matter, September 2, 1915, at the Post Office, Philadelphia, Pa., under Act of March 3, 1879.

Practical articles and notes on topics pertaining to the aquarium and terrarium are always wanted for AQUATIC LIFE. Readers of the magazine are invited to join in making it a medium of mutual help, and to contribute to it any ideas that may occur to them. The pages are always open for anyone who has anything helpful and practical to say. Manuscripts, books for review and general correspondence should be addressed to the editor.

AQUATIC LIFE has the largest circulation of any magazine in the world devoted to this branch of nature-study. It presents to advertisers a market that can be reached through no other medium. Rates made known on application.

Yearly Subscription\$1.00
 Foreign Subscriptions 1.35
 Single Copy10

Payments may be made by money order, draft or registered letter. Foreign remittances should be by international money order. If local checks are sent, ten cents should be added for collection charges.

Copyright 1917 by Joseph E. Bausman

Vol. II August, 1917 No. 12

lected to bear the eggs. Slowly, with ovipositor extended, the female, with her body at an angle of 45 degrees, ascended the leaf and expelled an egg. The male followed leisurely, and fertilization was effected. The eggs normally adhere to the leaf, but in the present case many were falling to the bottom and being devoured.

The eggs hatch in a warm temperature in about two and one-half days. For about a week the fry are moved from leaf to leaf, to which they adhere, by the parents, when they reach the free-swimming stage. Though Mr. Paullin's

fish have spawned a number of times during the past few years, but once has he succeeded in raising the young to maturity. (*Pterophyllum*, fin-race; *scalare*, a ladder, to climb.)

The Toledo Aquarium

The temporary home of the Toledo Aquarium was opened to the public on Monday, July 2, at 223 Superior street.

In connection with the aquarium there will be established The Aquarium Book Shop, to help pay the expenses of the exhibition.

Dr. A. de Clairmont has in press a pamphlet for free distribution, giving the story of the aquarium, as far as it is now built, and how it is proposed to establish in this city one of the largest marine aquariums in the United States, which promises not only to be a source of educational interest and pleasure, but to those who desire to join in the movement it will be a source of handsome profits in more ways than one.

The present exhibition consists of food fishes found in the vicinity of Toledo. In spite of the cramped space available for the exhibition, the tanks present a very favorable appearance, equal to those of any other aquarium in the States.

The Aquarists' Vade Mecum

During September the title page and index to the present volume will be published. Copy will be mailed to readers who request it upon receipt of stamp.

Volume II, in substantial cloth binding, with title page and comprehensive index, will be ready for distribution October 1st. The volume contains 164 pages, and about the same number of illustrations, some in color. Price, \$2.25, postpaid. Inasmuch as the number is limited, orders should be placed at once. The cloth edition of the first volume was exhausted within four months.

Otto Walter

86 Suydam Street :: Brooklyn, N. Y.
Near Evergreen Avenue L Station

Breeder and Importer of

TROPICAL & GOLDFISHES

Telescopes Calicos Japs Fan-tails

Dealer in All Varieties of Aquatic Plants

All Kinds of Fish Foods

Fresh and Dried Daphnia

AQUARIA, UTENSILS AND SUPPLIES

OSCAR LEITHOLF

433 Fourth Avenue - Pittsburgh, Pa.

TROPICAL FISHES

PLANTS :: SNAILS

Planorbis corneus Var. rubra

Paludina vivipara

Aquarium: 281 Southern Avenue

Write for Price List

GOLDFISH SPAWN

From Choice Telescopes & Japs, \$2 per 100 Eggs

I. X. L. Regular and Baby Fishfood, 10c. Box

W. E. WALP

1309 NORTH 55TH STREET PHILADELPHIA

LORQUINIA—The Naturalist's Monthly of the Southwest

Is published monthly by the Lorquin Natural History Club, and contains original observations of naturalists, particularly of the West. Associate membership, including subscription, \$1.50 per year.

LORQUIN NATURAL HISTORY CLUB,

1051 West 23rd Street, Los Angeles, Cal.

GEORGE'S GOLDFISH SHOP

Goldfish of All Varieties

George's Imperial Fish Food : 10c Postpaid

Dried Shrimp : : Box 10c, per pound 60c

PLANTS AQUARIA ALL SUPPLIES

N. W. 60th and De Lancey Street, Philadelphia

EDWARD S. SCHMID

Emporium of Pets

All Kinds of Goldfishes and Aquatic Plants
Water Lilies

712 Twelfth Street, N. W., Washington, D. C.

Taxidermy Send for Catalog

ENCHYTRAE (White Worms)

The ideal live fish food which can be raised indoors all year round. Portion 50c (cash or money order) with instruction how to breed them

CHARLES E. JENNE

1577 Paterson Plank Road, Secaucus, N. J.

DRIED SHRIMP

The General Utility Food for Fishes.

Per pound, coarse, 75c.; fine ground, \$1.

St. George's Natural Fish Food, \$1.50 lb.

Sample can, 15c Add postage to your zone

CANADIAN BIRD STORE,

2139 West Van Buren Street, Chicago, Ill.

FOR SALE — Hundreds of breeding Guppies (Lebistes reticulatus). The most beautiful ones you ever saw. Your choice 25c each. Large breeding Helleri 75c each. All kinds of Snails and Tropical Fishes.

V. VARJE, 1361 N. Clark St., Chicago, Ill

Telephone, Superior 4415



All aquaria fish thrive on
RELPAW Imported Hygienic
Natural Fish Food, 10c Box
Ask Any First Class Dealer

N. WAPLER, Importer
28 Warren St., N. Y. City

BETTER CUTS AT

BETTER PRICES

PROMPT SERVICE GUARANTEED

GOULD-WILHELM CO. INC.

ARTISTS * ENGRAVERS * PHOTOGRAPHERS

44 N. 4TH STREET PHILA.

SEND FOR SAMPLES AND PRICES THEY WILL INTEREST YOU!

IF YOU

Are Looking for Something Extra
Fine in Broad-tail Telescopes

Don't Forget W. H. HEIMBACH

Breeder and Importer of FINE FISH

Snails Plants

FISH FOR SALE AT ALL TIMES!

413 NORTH TENTH STREET

ALLENTOWN, PA.

HERMAN RABENAU, Aquarist

PERMANENT DISPLAY OF Aquatic Life & Terraria

must be seen to be appreciated
Visitors Welcome

Plants and Tropical Fish a Specialty
Importations of New Varieties received
regularly

1163 Myrtle Avenue, Brooklyn, N. Y.
Near Broadway.

THE BRUCE FISHERIES

Breeder, Importer, Wholesale & Retail Dealer in

**All Kinds of Goldfish
Comets a Specialty**

ELGIN K. BRUCE, THORNBURG, IA.

"AQUARIA FISH"

A practical work on care and breeding of fish in the Aquarium, Greenhouse and outdoor Ponds. Finely illustrated. Every one interested in keeping fish should send for a copy of this book. Price, \$1.
Four-Horned Snails (*Ampullaria Gigas*) deposit a mass of large coral red eggs out of the water, the little snails drop into the water as they hatch. These snails are invaluable for destroying Hydra in the aquarium.

Thoroughbred Collie Pups, beautifully marked.

F. L. TAPPAN

Route 2, Hopkins, Minn.

FRANKLIN BARRETT

EVERYTHING COMPLETE FOR THE
AQUARIUM, POND AND LAKE

Wyoming Avenue, & C Street, Phila., Pa.
SEND FOR PRICE LISTS

Winners

My **Broad-tail Telescope Goldfish** were awarded firsts and three special prizes at the last annual exhibition of the Aquarium Society held in the American Museum of Natural History, New York. Young stock from these fine fish for sale during the coming season. Watch my future ads.

Otto Gneiding's Goldfish Hatchery

31—37 Depot Ave., Ridgefield Park, N. J.

Use Regenia Aquarium Salts

To replace the natural salts in your aquarium as absorbed by the fishes and snails. Excellent for plants. Help the snails form shell. Benefits the fish. **Box of Six Powders, 25c.** For sale at Pet Stock stores.

Violet-Ray Fish Remedy

Relieves Constipation, Fungus, Tail Rot, Congestion in fancy fishes; also white spots on Tropical fishes. **Box of Six Powders, 25c.** Safe and effective.

REGENIA CHEMICAL CO.

Station K.

Philadelphia

THE TERMINAL PET SHOP

PETS OF EVERY DESCRIPTION AND KIND

Manufacturing and Maintenance of Aquariums a Specialty

All Kinds of Cat and Dog Foods and Medicines

HUDSON TERMINAL BUILDING

Concourse, New York

S. A. SCRIMSHAW

I make the strongest steel aquarium on the market. All in one piece, seamless and rust-proof. Finished in antique bronze or imitation of any wood.

Rock Gardens, Ponds and Decorations for the Lawn and Conservatory. All Kinds of Tropical Fishes and Aquarium Supplies

For Sale—Forty Mountain Trout from Glacier National Park

1361 N. Clark Street :: Chicago, Illinois

Telephone, Superior 4415

Fine Broad-tail Telescopes BLACK & CALICO

Correspondence Solicited

GEORGE WILT, 1519 N. 62nd Street
PHILADELPHIA

EVERYTHING IS FISH THAT COMES TO THE NET OF A NATURALIST

Don't paddle in the water with one hand and be blind with both eyes. In other words "keep your eyes open" for all nature.

Our Magazine

The Guide to Nature Will Help You

It is edited by EDWARD F. BIGELOW, who fishes in the heavens and earth, as well as the waters under the earth.

Four months' trial, 25c. One year, \$1.00

THE AGASSIZ ASSOCIATION

ArcAdiA

Sound Beach

Connecticut

New Aquarium Book

GOLDFISH VARIETIES AND TROPICAL AQUARIUM FISHES

By *Wm. T. Innes*

This work is endorsed by the U. S. Bureau of Fisheries and leading fanciers. It is thoroughly practical in every respect, and is written so plainly that a beginner may easily understand every point. 170 beautiful illustrations, mostly from life, including prize winning Goldfishes. 19 chapters. Gives alphabetical list of 300 aquarium fishes, their breeding, foods, temperatures and care in detail.

Sent anywhere upon receipt of Price \$3.00

Perfect Photograph of the Best Moor Goldfish

Life-size, Natural, Extremely Handsome Price 50c

We will enclose one of these prints with each copy of our new book, "Goldfish Varieties and Tropical Aquarium Fishes," where we send two or more books at retail to one address.

INNES & SONS, Publishers
129 - 135 N. 12th Street
Philadelphia



Now is the time to list the Aquarium Vacuum Cleaner in your Fall Catalogues. We are receiving repeat orders wherever it is placed and frequent inquires from private parties asking who our representatives are.

*Samples by Parcel
Post, 50c, 75c, \$1.00*

Dealers Write for Discounts

Mfg'd by

Acton Electric Co., Inc.

1133 BROADWAY
NEW YORK

Patents Pending

TEN VARIETIES OF BEAUTIFUL AQUARIUM PLANTS

for \$1.00 Postpaid

J. HENRI WAGNER, 1909 North Capitol
Washington, D. C.

WALTER BELL

Breeder of Broad-tail Telescopes
BLUES BLACKS CALICOS
4324 WYALUSING AVENUE, PHILADELPHIA
Prices Reasonable

CARL LAZER

Dealer and Breeder of Tropical Fishes
Aquarium Plants Red Snails
All Kinds of Aquaria and Supplies
Open Evenings and Sunday
647 West 184th Street New York City, N. Y.



**What's the Object?
See you later!**

AQUARIUM STOCK CO

150 Chambers Street :: New York City

Aquarium Specialists

GOLDFISH, FOODS, PLANTS, SNAILS, ETC.

Combination Natural Fish Food - Sample Can 10c
Imported Shrimp Fish Food - - Sample Can 15c
Imported Wafer Fish Food Large Sample Box 10c

Special Prices on Quantity Lots Cash With Order

Catalogue Sent Upon Request

Orders amounting \$2 delivered postpaid.
Mail orders promptly attended to.

CRESCENT FISH FARM

Breeders and Collectors of

Goldfish and Other Aquarium Fishes

Alligators, Turtles, Chameleons, Snails, Water Plants

We are now booking orders for
Fall shipments of. *Mollienia*
latipinna, *Gambusia holbrooki*
and *paradise* Fish.

1624 Mandeville Street, New Orleans, La.

Michaelsen Bros

**GOLDFISH
BREEDERS**

FLORISTS

58th and Walnut Streets

110 South 52nd Street

Philadelphia

Aquarium Fishes

All Kinds of Aquatic Plants

Aquaria & Supplies

Wholesale and Retail

HARRY P. PETERS

1210 N. Warnock Street, Philadelphia, Pa

BREEDER AND IMPORTER

Rare and Fancy Fish

Plants of every variety, Snails and Aquarium Supplies of all kinds at all times.

MANUFACTURER OF

Green River Fish Food

15c Box

Green River Baby Fish Food

20c Box

A GOOD FISH FOOD is one of the most essential things necessary to keep fish in good health. After the test of years Green River stands out as the best food on the market. It keeps the fish in good color by promoting a healthy, robust growth. It will not sour or cloud the water. Ask your dealer or send for it today.

Nippon Goldfish Co

1749 Buchanan Street, San Francisco, Cal

Importers : and : Dealers

JAPANESE GOLDFISH

DIRECT FROM BREEDERS IN JAPAN



Awarded Gold and Silver Medals

Panama-Pacific International Exposition

San Francisco, 1915

ALL KINDS OF AQUARIA AND SUPPLIES

Price Lists Furnished to the Trade Only

Breeders

A large assortment of splendid Telescope and Jap goldfish at reasonable prices.

Fine Assortment of Lionheads

Shipping Cans, 45 Cents.

Young Blues, Blacks & Calicos \$1.50 Doz

Young Veiltails or Broadtails \$5.00 Doz

HARRY P. PETERS

1210 N. WARNOCK STREET

PHILADELPHIA

GREEN RIVER FISH FOOD

Due to the constant increase in costs of ingredients, boxes and printing, it has become necessary to increase the price of these foods to 15 and 20 cents. When conditions again become normal the old prices will again prevail.

HARRY P. PETERS,

1210 North Warnock Street,

Philadelphia, Pa.



3 2044 072 182 561

