

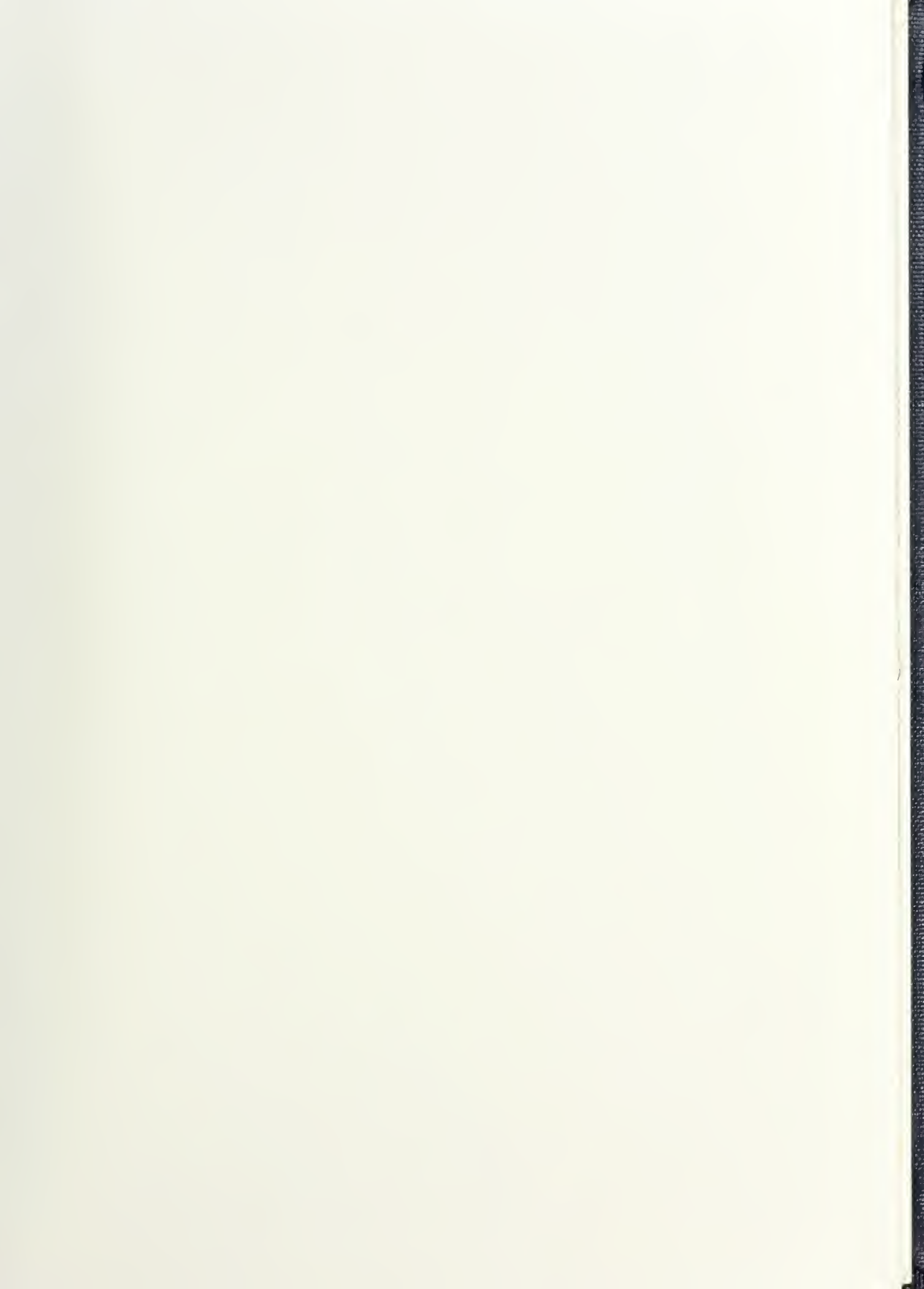

DUNN E. OF LIBRARY
MARIA FRANCIS STATE SCHOOL
MONTEREY, CALIFORNIA 93943-8002





VALUE ENGINEERING IN THE CONSTRUCTION PROCESS

A Special Research Problem

Presented to

The Faculty of the School of Civil Engineering
Georgia Institute of Technology

by

Barry Kent Loveless

In Partial Fulfillment
of the Requirements for the Degree of
Master of Science in Civil Engineering

1986

GT

GEORGIA INSTITUTE OF TECHNOLOGY

A UNIT OF THE UNIVERSITY SYSTEM OF GEORGIA

SCHOOL OF CIVIL ENGINEERING

ATLANTA, GEORGIA 30332



VALUE ENGINEERING IN THE CONSTRUCTION PROCESS

A Special Research Problem

Presented to

The Faculty of the School of Civil Engineering
Georgia Institute of Technology

by

Barry Kent Loveless

In Partial Fulfillment
of the Requirements for the Degree of
Master of Science in Civil Engineering

1986

T230697

VALUE ENGINEERING IN THE CONSTRUCTION PROCESS

A Special Research Problem

Presented to

The Faculty of the School of Civil Engineering

ABSTRACT

This research paper discusses the principles and procedures of the Value Engineering discipline. Value Engineering has been practiced for over 30 years in the manufacturing sector of the economy, but has never been fully accepted in the construction industry. The paper discusses the theory and methodology supporting the application of Value Engineering, and the manner in which it can be applied to the various phases of the process of constructing facilities. Specific applications of Value Engineering, which can be beneficial for construction managers are discussed. Case studies where Value Engineering has resulted in significant cost savings, and examples of current construction industry practice are presented.

TABLE OF CONTENTS

	<u>Page</u>
Chapter 1 -- Introduction	1
1.1 The Concept of Value.....	1
1.2 History of Value Engineering/Analysis.....	2
1.3 Value Engineering in the Construction Industry.....	3
1.4 Objectives.....	4
Chapter 2 -- Functional Analysis	6
2.1 General.....	6
2.2 Identify and Classify the Functions.....	6
2.3 Establishing Worth Versus Cost.....	9
2.4 Graphical Function Analysis.....	12
2.5 Function Analysis System Technique (FAST).....	13
2.5.1 Background.....	13
2.5.2 Procedure.....	14
2.5.3 FAST Example.....	16
Chapter 3 -- Value Engineering Methodology	19
3.1 Background.....	19
3.2 Orientation Phase.....	19
3.3 Information Phase.....	20
3.4 Speculation Phase.....	21
3.5 Analysis Phase.....	25
3.6 Development Phase.....	27
3.7 Presentation.....	28
3.8 Implementation and Followup.....	29

Chapter 4 -- Value Engineering in the Construction Process.....	31
4.1 Introduction.....	31
4.2 Budgeting and Programming.....	32
4.3 Design.....	36
4.4 Construction.....	38
4.5 Study Team Procedures.....	42
4.6 Project Selection.....	46
4.6.1 Breakdown Analysis.....	47
4.6.2 Cost/Worth Model.....	48
4.6.3 Life-Cycle Cost Model.....	50
Chapter 5 -- VE Applications for Construction Managers.....	53
5.1 Problem Solving.....	53
5.1.1 Introduction.....	53
5.1.2 Systematic Approach.....	54
5.1.3 Weighted Criteria Evaluation.....	57
5.1.4 Tradeoff Evaluation Process.....	59
5.2 Procurement.....	62
5.3 Cost Control.....	63
Chapter 6 -- Value Engineering State of the Art.....	64
6.1 Current Industry Practice.....	64
6.2 HVAC Applications.....	69
6.3 Government/DOD Programs.....	73
6.4 Case Studies.....	76
6.4.1 Willow Creek Dam.....	76
6.4.2 Training Building.....	77
6.4.3 Office Building Energy Evaluation.....	79
6.4.4 Wastewater Treatment Plant.....	80

Chapter 7 -- Integration and Conclusion.....	83
7.1 Management Participation.....	83
7.2 Value Management Organization.....	85
7.3 Training.....	88
7.4 Conclusion and Recommendations.....	91
Appendix A -- Examples of VE Proposals.....	92
Appendix B -- VE Job Plan Checklists.....	117
References.....	131

CHAPTER 1

INTRODUCTION

1.1 The Concept of Value

The value of a product or service is determined by considering its performance versus cost. If both performance and cost are considered appropriate, then it can be generally stated that the product or service has good value. Therefore, in order to increase value, one must decrease costs (while maintaining equal performance), or increase performance at an appropriate additional cost.

Maximum value is a goal of all parties purchasing products and services in a free enterprise system, yet it can probably never be defined or obtained. The degree of value obtainable is determined by the results of competition within the economy. The winner of the competition is the supplier whose product best serves the customer's needs at the lowest price (31).

Value Engineering (VE) or Value Analysis (VA) is a creative, organized approach whose objective is to optimize cost and/or performance of a product, facility, or system (13). A systematic approach is applied, which seeks to reduce the performance of the product down to only those features required by the customer. It is concerned with elimination or modification of any item which adds cost to the product, without contributing to its required functions. If an item adds neither quality, usefulness, life, aesthetics nor customer desired features to the overall product, then value analysis/engineering seeks to eliminate the item.

Value Engineering differs from conventional cost reduction methods in that the required performance, reliability, quality, and maintainability of the product is not compromised. Conventional cost cutting has frequently concentrated on the reduction

of labor and material costs, which often resulted in inferior products. There is a significant difference between inexpensive materials and cheap materials, and between simplified workmanship and poor workmanship. Proper value engineering work does not allow for any reduction in product quality or performance.

The basic concept of VE is that providing anything less than the performance required by the owner is not acceptable, and providing anything more should be avoided unless it can be done with no additional cost. VE is not the technology of one specific science, but rather it incorporates available technologies with the concepts of economics and business management (18).

1.2 History of Value Engineering/Analysis

Value engineering evolved from the scarcity of manufacturing materials caused by the wartime economy of World War II. Harry Erlicker, a vice-president of the General Electric Company, observed that some of the materials substituted for unavailable ones frequently performed better and at lower costs. This convinced him that significant benefits could be realized if these substitutions were intentionally developed. The task of developing a systematic approach for pursuing these substitutes was assigned to a staff engineer named Lawrence Miles in 1947.

During the next five years Miles and his staff developed techniques and a methodology for more effectively improving value. The method was called value analysis, and after it was accepted as a standard at G.E., gradually other companies and governmental organizations adopted the new approach for reducing costs.

The first federal agency to formally adopt the value analysis method was the Naval Ship Systems Command (formerly the Bureau of Ships) in 1954. The program was retitled "value engineering" because this better reflected the nature of the

shipbuilding business. Subsequently, many federal agencies adopted the VE method. In 1954 Secretary of Defense McNamara called VE the key element in the drive to reduce defense costs, and value engineering was included as a mandatory requirement by the Armed Services Procurement Regulations (ASPR) (40). One objective of the program was to achieve a savings of \$10 for each \$1 spent in investigating alternative methods and materials.

1.3 Value Engineering in the Construction Industry

The ASPR was oriented toward the purchase of materials, equipment, and systems, but it also had the effect of automatically introducing value engineering to two of the largest construction agencies in the country: the U.S. Army Corps of Engineers, and U.S. Naval Facilities Engineering Command.

Until 1972, value engineering had not received much interest within the construction industry. The Society of American Value Engineers (SAVE) in their twelfth annual conference chose to emphasize applications of value engineering to the construction industry. SAVE was chartered in 1959, and with many of its members coming from the federal government, it was the leader in the evolution of value engineering, particularly in the government agencies. The SAVE conference provided a forum where architects, engineers, contractors, and other industry members heard of the progress and accomplishments of established VE programs (40).

The attendees at the next year's conference were over half made up of representatives from the construction industry. The first discussion of the application of value engineering to a major project was presented by the vice-president of Paschen Contractors (40). As a result of the increased awareness of VE applications to the construction industry, AT&T was the first private sector corporation to adopt a

company-wide value engineering program. It initially introduced the technique to its communication facilities. Many more private firms have since introduced the value engineering concept to their construction projects (40).

The Japanese were the first foreign country to adopt the value engineering concept in 1970. The Italians followed in 1978, and since then other countries such as Australia, Canada, India, England, South Africa, France, and Germany have seen construction-oriented value engineers begin practicing (13).

Value engineering has been proven as one of the best methods for counteracting the rising costs of construction. Despite the proven track record of savings when applied properly, only a small percentage of the construction actively utilizes the technique. VE concepts are one tool for the construction manager to use to achieve the goal of providing a facility which meets the owner's functional, quality, and aesthetics criteria at the lowest possible life-cycle costs.

1.4 Objectives

Nearly all construction projects are accomplished while working within budget constraints. Construction managers are constantly concerned with reducing costs whenever possible. Value engineering has a proven track record of success for eliminating unnecessary costs when applied to construction projects, but it has not been accepted as a common practice by the majority of the industry.

There are common misconceptions about VE. Some say that it is just another name for traditional cost-cutting techniques. Others think of it as merely finding new or different ways of doing things. One of the most common misconceptions is that if a design is properly completed, then there is no need for VE because a good designer should take into consideration all the factors that VE does.

The objectives of this research are to address these misconceptions by thoroughly examining the techniques of value engineering. The theory of VE and the formal procedures for its application will be presented. The flexibility of the method will be demonstrated by showing how it can be applied in many different situations. Examples will be given of projects which have used the method successfully.

The aspects which differentiate VE from traditional cost reduction methods will be presented, as will the integration of VE techniques into all phases of the construction process. VE will be shown as a powerful technique to be used by managers in all industries, especially construction.

The research will examine successful VE programs and current applications in different sectors of the construction industry. Finally, recommendations for establishing and operating a successful VE program in the construction context will be presented.

CHAPTER 2

FUNCTION ANALYSIS

2.1 General

The key feature of value engineering in construction, which distinguishes it from other cost reduction approaches, is the user-oriented function approach. The essential point to remember is that the customer wants a facility to perform a function. He has a need and he has certain minimum requirements and limits on the manner in which he wants the function performed. The user's needs include the performance qualities, traits, aspects of appearance, or other characteristics that the facility must possess if it is to be useful and efficient in working, selling, producing revenue, or meeting whatever other goals that the owner has for it.

The user's needs are the objectives, and the design details the means which will be used to meet those needs. Value engineering focuses on those needs, instead of a specific facility or system which already performs a function, but which may not match the desired function. Most conventional approaches start by accepting a facility or system, and then proceeding to seek ways to make it cost less (13).

2.2 Identify and Classify the Functions

Function analysis begins by breaking the project down into components or areas, and specific functions being performed. Function is the basic purpose of an item or expenditure, or it may be a characteristic that makes the item work or makes it sell (52). Concise and accurate descriptions of the functions should be generated. The language of the function statements is very important for accurate identification. The owner or user desires only two types of functions in varying degrees: *use functions* and

aesthetic or *esteem functions* Use functions perform the desired action, while *esteem functions* provide the desired "style" with which the action is performed (31).

A project or subsystem of a project which is to undergo functional analysis requires that the following questions be answered (30):

What is it?

What does it do?

What is it worth?

What does it cost?

What else will perform the function?

What does that cost?

The function is broken down into its most basic form by expressing it by only two words: a verb, and a noun. For example, the basic function of a doorway is to "provide access", and a chair "supports load", while a wire "conducts current." Some typical verbs which can be used to describe construction functions are:

absorb	enclose	protect
amplify	filter	reduce
collect	close	shield
transport	transmit	conduct
support	prevent	provide
control	reduce	reflect
separate	condition	fasten
insulate	mount	divide

The nouns may be either use oriented, and therefore measurable, or aesthetic (40).

Examples of each are as follows:

<u>Measurable</u>	<u>Aesthetic</u>
current	appearance
heat	beauty
load	convenience
voltage	form
power	prestige
volume	style
vibration	symmetry
sound	effect

The verb identifies the item's required action, and thus answers the question: What does it do? The noun identifies what is acted upon, and it should be measurable, or understood in measurable terms. The reason for the requirement for measurability is that the item's value will be determined during the process of relating cost to function. Vague or nonmeasurable statements of function make the determination of value very difficult, if not impossible.

The function statements which contain nonmeasurable nouns are *aesthetic functions* and they relate to pleasing the customer or user. Examples of this type of function are: provide beauty, improve appearance, and assure convenience. These functions "sell" the owner on selecting your project proposal instead of a competitor's, or on accepting additional costs over the bare use function costs in order to obtain a more pleasing product (31).

Describing the function is much more difficult than it appears. Complete understanding of the item is required to select the proper two-word description. The

problem lies in the fact that many two-word descriptions may apply to the item. However, only one of the descriptions is the *basic function*. This *basic function* is the feature of the item or system, which is the primary reason for its existence. Any other descriptions may be important, but they are not controlling (40).

These nonessential functions are described as *secondary functions*, and they answer the question: What else does it do? *Secondary functions* describe performance features not considered essential, and therefore usually have zero use value, but they can contribute considerable cost to the product, and thus are a good target for value engineering work. A good example of the relationship between *basic* and *secondary* functions is the descriptions of functions for a door. The *basic* function of an exterior door is to provide access, but secondary functions may be: provide security, exclude weather, and express prestige. The value analysis approach will attempt to reduce overall costs by eliminating as many *secondary* functions as possible, and preserving the *basic* function, but reducing its cost (40).

2.3 Establishing Worth versus Cost

Once the functions have been identified, concisely stated, and understood, it is necessary to establish an appropriate cost or value for the functions. Worth is a measure of value for a particular item, and is the least expenditure required to provide the functions needed by the owner or user (40).

Several methods can be used to establish the worth of a particular function. The costs of previous items which performed the same function is one measure of worth, and the comparison with minimum costs of other recently completed designs is another way. An example of establishing the worth of an item is examining the basic function of an electrical cable, which is to "conduct electricity." A single strand of aluminum

wire could perform this function, so the worth of the function is the cost of the piece of wire. Another example of establishing worth in value analysis is the worth of a tie clip. The basic function of the clip is to "hold tie," which could be accomplished by a single paper clip, so the worth of the function is the cost of a paper clip. But if the user desires the clip to "connote prestige" by its appearance, then this may be the basic function for him, and the cost of a paper clip may not indicate the proper worth (31).

The next step to be taken is to determine the current price being paid for the item, and relate this to the estimation of worth. The current engineer's estimate is the best source for the cost figure. The value index which results from this comparison is shown as follows:

$$\text{Value Index} = \frac{\text{worth}}{\text{cost}} = \frac{\text{utility}}{\text{cost}}$$

Observation of the equation shows that value may be increased by improving utility, with no increase in cost, maintaining the same utility, with a decrease in cost, or combining an increase in utility, with a decrease or lesser increase in cost (40).

The value index serves three purposes for the value engineer. If the index returns a value of greater than one, then optimum value is not indicated, and the determination can be made to proceed with the value study. Good value would be indicated by a value of one or less. The second benefit from the index is the identification of areas with the greatest cost-to-worth ratios. These areas normally will yield the greatest possible cost savings, so they present the best potential areas for the study. The last thing the index will do is provide a measure of the effectiveness of the VE study after completion. If the index is at or close to unity after the study is completed, then it has been effective (13).

A very simple example which serves to illustrate the principles of function analysis

and the concept of value is a pencil. The first step is to define the basic function in a two-word statement, which in this case is "make marks." Next, each component of the pencil is identified along with the various function or functions it performs. They are as follows:

- Eraser "removes marks"
- Ferrule "holds eraser"
- Wood "holds lead"
- Paint "protects wood" and "provides beauty"
- Markings "identify product"
- Graphite "makes mark"

As you can see, the paint has more than one function. The next step is to determine which of these functions are primary or secondary. All the functions performed by the components are classified as secondary, except the graphite. If the pencil was produced to advertise the firm's name, then the markings would be a primary function, but this is assumed not to be the case (13).

The costs to produce each component are next obtained, and the worth of each item is assessed. Since the graphite is the only component with a basic function, it is the only one that has worth. The last step is to compute the Value index or cost-to-worth ratio. The summary of the analysis is shown in figure 2.1 (13).

Function Analysis - Pencil

Component	Verb	Noun	KInd	Original Cost	Worth
Pencil	Make	Marks	B	\$0.14	
Eraser	Remove	Marks	S	\$0.02	
Ferrule	Hold	Eraser	S	\$0.01	
Wood	Hold	Lead	S	\$0.05	
Paint	Protect	Wood	S	\$0.01	
	Provide	Beauty	S		
Markings	Identify	Product	S	\$0.01	
Graphite	Makes	Marks	B	\$0.04	\$0.04

$$\text{Cost/Worth Ratio} = \$0.14/\$0.04 = 3.5$$

Figure 2.1 - Function Analysis of a Wooden Pencil

The value index has a value of 3.5, which is greater than unity, therefore additional savings potential is indicated. The method shows that the wood contributes over a third of the cost to the pencil (\$0.05/\$0.14), but it performs a secondary function. This indicates that the wood would be a key area for potential savings (13).

This was a greatly simplified example, but serves to illustrate the procedure. For an actual construction project, the components are evaluated and compared with previous designs or experience. The costs which appear to be excessive are targeted for more in-depth study.

2.4 Graphical Function Analysis

Another useful method for performing function analysis is by graphical means. This method gives a better presentation to the analyst for quicker identification of areas for study. The graph is intended to point out the potential costs savings areas more strongly than merely numbers (13).

An example of this method was used for an air conditioning system for a particular

facility. The system was broken down into components, and the cost of each component, along with its worth were displayed on a bar chart. Figure 2.2 shows the completed chart.

The chart readily pointed out the areas which accounted for the greatest cost in the project. The ducts and diffusers, electric supply, and equipment room space accounted for 60% of the cost of the system, but poor value was indicated. These areas were targeted for more in-depth study in order to reduce costs (13).

2.5 Function Analysis System Technique (FAST)

2.5.1 Background

A technique for showing specific relationships of all functions, which have been identified within the value engineering effort, was developed by an engineer, named Charles Bytheway, from UNIVAC in Salt Lake City. The method was named the Function Analysis System Technique (FAST), and it has importance to the value engineering studies, as well as by many other companies and individuals for a problem-solving technique (13).

The technique seeks to stimulate organized thinking by asking questions based on What? Why? and How? Similar to the system used in basic function analysis, the subject in FAST is expressed as a two-word verb and noun function. FAST does allow for the occasional modifier, thereby expanding the two-word function where considered essential. The resulting functions are arranged in a hierarchy as they relate to each other, and these are called FAST diagrams. The logical hierarchy graphically represents how the functions interact together to produce the desired end result (11).

FAST diagrams are effective communications tools. They clearly show the importance of subproblems. They help personnel in the organization see what their

Graphical Functional Analysis Air Conditioning System

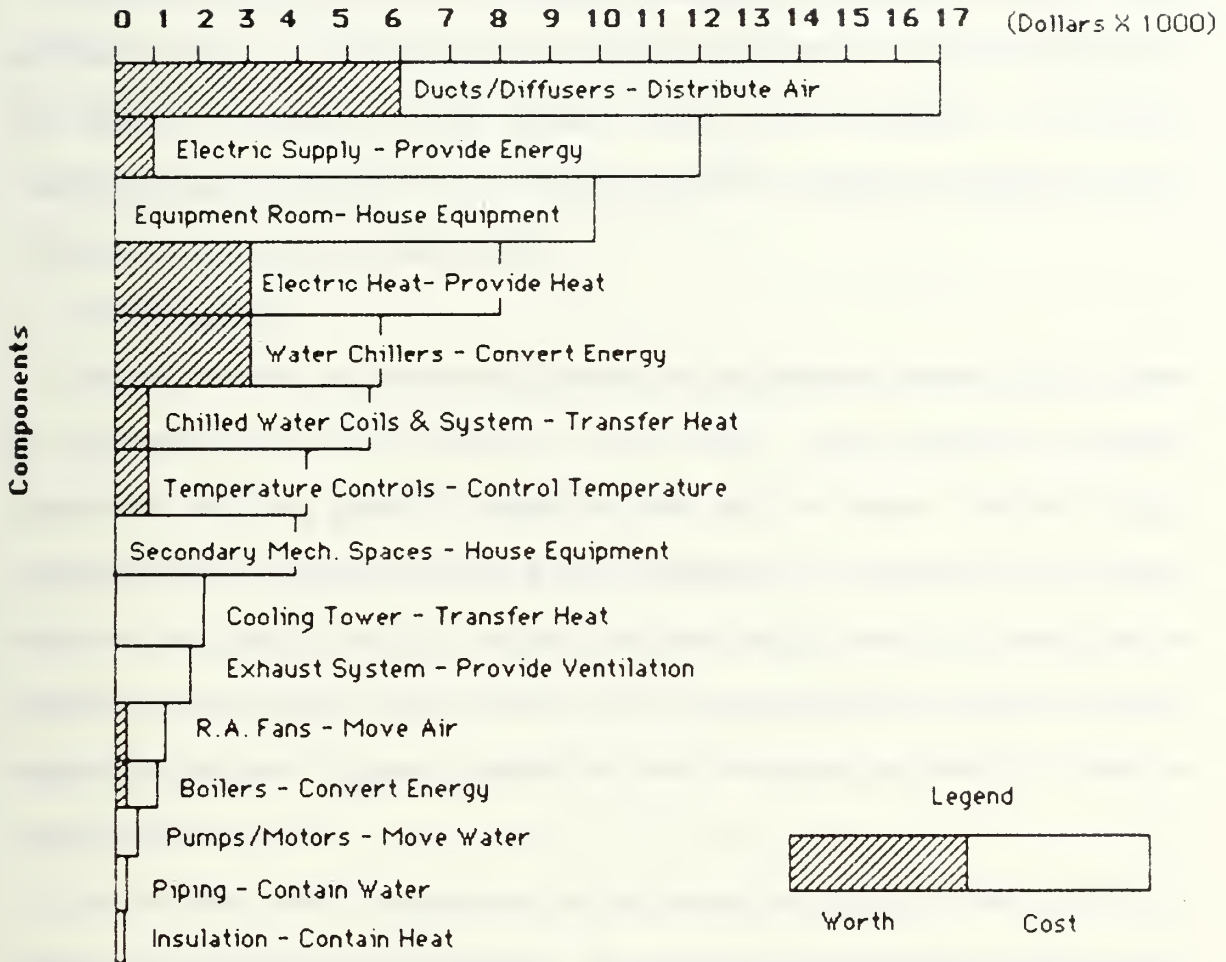

Figure 2.2 - Graphical Function Analysis

own problems are, how these problems affect the overall objective, and what the limits on the scope of their roles are (52).

The benefits gained from the completed diagram are secondary compared to the process by which it is constructed. The in-depth thinking and creativity that go into the diagram preparation are the greatest assets of the technique. A correctly completed diagram indicates that the problem has been completely analyzed, and that all functions have been considered (52).

2.5.2 Procedure

The FAST diagram can be started anywhere in the system or project being studied by considering one of the functions in the system. Each function is analyzed individually, and then placed in sequential order with the others. The left-to-right progression of the diagram indicates a time relationship. Functions to the left occur before the functions to the right, and any functions which occur at the same time are positioned above or below. Those which occur at the same time are called concurrent supporting functions. Figure 2.3 depicts the basic evaluation procedure to be done on each function (13).

The function under examination, which should be in the two-word form, is subjected to a How and a Why question. The answers to the questions should also be two-word function type statements. The answer to the Why question is positioned to the immediate left of the function, while the answer to the How question is placed to the right.

The How question should be phrased: "How is (verb) (noun) accomplished, or how is it proposed to be accomplished?" The Why question is phrased: "Why is it necessary to (verb) (noun)?" If either of the functions placed to the left or right of the function being analyzed do not provide a logical answer to the questions, then the answers have

Diagrammatic Description of FAST

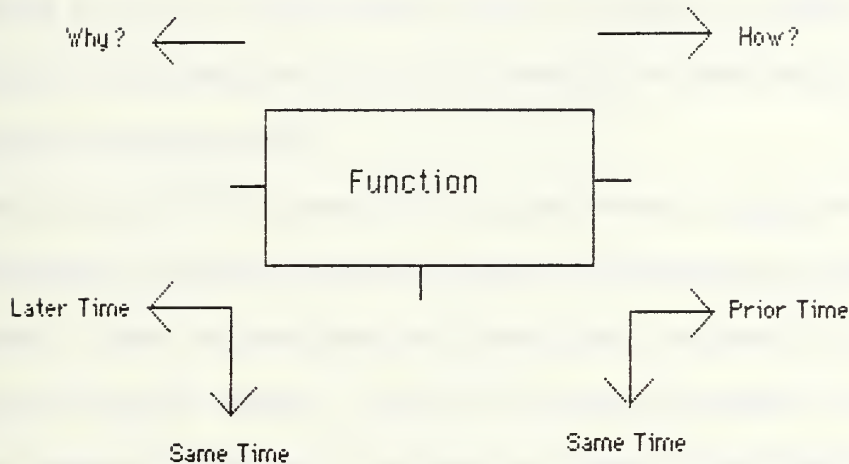

Figure 2.3 - Diagrammatic Description of FAST

either been described improperly, or they have been placed in the wrong sequence. For example, the function being analyzed may be "generate profit." The question is asked "Why is it necessary to generate profits?" The answer may be to "maximize return-on-investment." This would be the function placed immediately to the left. The next question to ask is "How is it proposed to 'generate profit'?" The answer to this question could be to "lease space," and this answer would be placed to the right (52).

The next step in expanding the diagram is to ask the How question of "lease space," and place it to the right. The answer of the Why question of "lease space" is already given by "generate profit." Similarly the Why question is asked of "maximize return-on-investment", and the answer is placed to the left. "generate profit" answers the How question for "maximize return-on-investment."

The path of functions is expanded until the basic function of the project or system

is shown on the far left of the diagram, and all the essential functions of the system are shown to the right. The functions which lie on the completed path are called critical path functions. These functions may not guarantee reliable or acceptable performance of the system, but they are the essential functions needed to achieve the basic function performance (30).

Functions which are not essential for the performance of the basic function are called supporting functions, and they are placed vertically below the functions which they support. These functions assist the critical path functions in performing in a reliable and acceptable manner. They can be required secondary functions of the system or aesthetic functions. They exist as a result of the method selected for performing a critical path function.

Each of the supporting functions may have its own critical path of functions required for its performance. These functions should be arranged on the diagram, and the diagram should be expanded down and horizontally until all supported functions are completely analyzed (30).

If there are any functions that are design objectives to keep in mind throughout the process, such as "conserve energy", they should be placed above the critical path in dotted boxes to the left. Aesthetic considerations for all functions, such as "minimize noise", or other functions which occur all the time, such as "provide utilities" or "provide access", should be placed above the critical path to the right (13).

2.5.3 FAST Example

A light bulb was selected as a simple example for demonstrating FAST procedures. The bulb with its basic parts is shown in figure 2.4. The FAST diagram will attempt to establish the critical path functions, supporting functions, and any unnecessary

functions performed by the bulb. These functions will then be arranged in a diagram which shows their interrelationships (30).

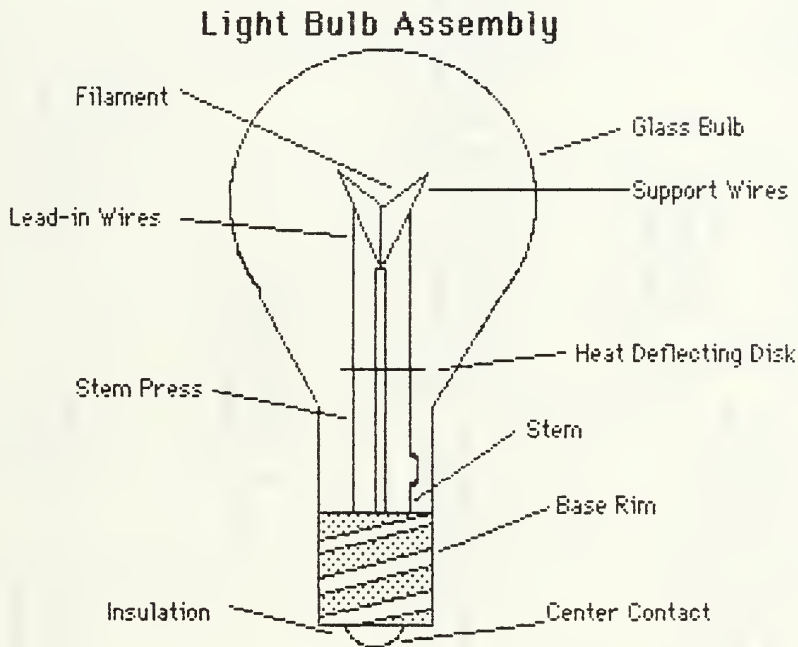

Figure 2.4 - Light Bulb Assembly

Figure 2.5 shows the completed FAST diagram for the light bulb assembly. Through function analysis, the bulb has been determined to perform seven critical functions: "mount lamp electrically", "connect lead-in wires", "conduct current", "supply power", "heat filament", "convert energy", and "produce light." These functions are all required to achieve the basic function "provide luminous energy" (30).

The How and Why answers should agree with the arrangement of functions. For example, Why is it necessary to "heat filament"? The answer lies to the left, which is "convert energy". How is "heat filament" accomplished? The answer lies to the right,

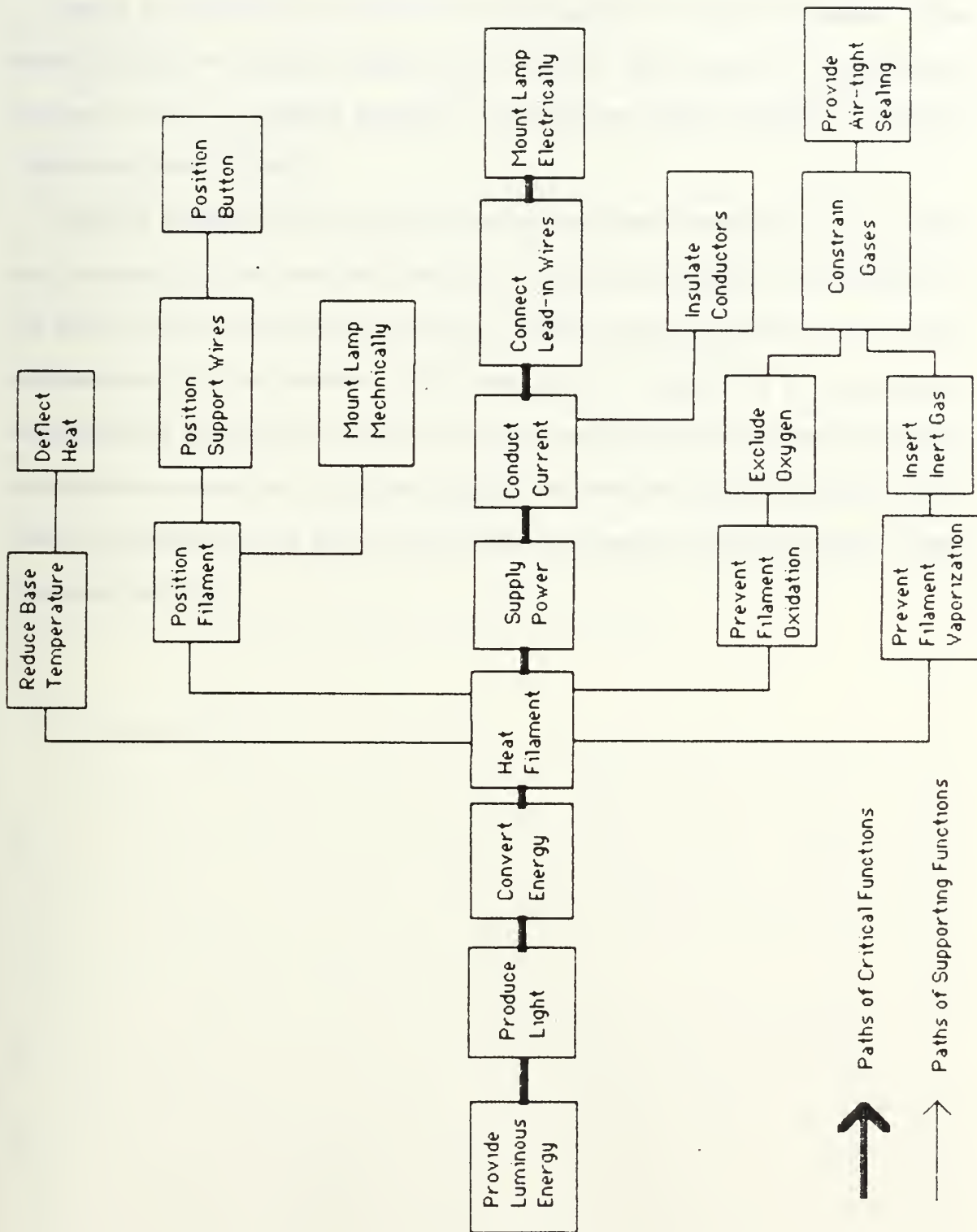

Figure 2.5 - FAST Diagram of Light Bulb Assembly

"supply power". The entire diagram should reveal the correct answers when analyzed in this manner.

One of the supporting functions to "heat filament" is "position filament". The answer to why we "position filament" is in order to "heat filament". There are two answers to how we "position filament", and they are "position support wires" and "mount lamp mechanically".

The FAST example for the light bulb could have been constructed in many other ways, depending on the needs and creativity of the persons doing the constructing. If the ground rules for construction always are followed, then the diagram will be a valid representation of the problem. The reason for the analysis is to visualize and understand the project more clearly. The thought and creativity processes which goes into diagram construction will let the analyzer see what the critical functions are, and that a supporting function has to be performed only because a critical function caused it to come into being.

Chapter 3

Value Engineering Methodology

3.1 Background

The results from function analysis are perhaps the most important tool for the successful accomplishment of a value engineering study, but there are other steps which must be accomplished. A disciplined system is required to combine all the techniques and procedures for a complete VE analysis of a project. The job plan contains a systematic procedure for accomplishing these tasks, and tying them together to come up with the best value alternatives for the project.

There have been several versions of the VE job plan developed. Some sources list five steps, while others list as many as eight. The number of steps is not the most important point, as they all accomplish the same objectives. The important consideration for the VE job plan is that an organized and systematic approach is taken which covers all the procedures for complete value analysis..

3.2 Orientation Phase

Orientation actually precedes the function analysis of a particular project or system. In this phase, the selection is made of what to study. Most construction projects are made up of thousands of items, systems, and subsystems, so the selection of the items which offer the greatest potential for cost savings is a very important step. A later section of this paper will discuss techniques that construction managers will find to be beneficial in this process of selecting areas of highest cost-saving potential.

Another important step to be taken in the orientation phase is assembling the project team. A multidisciplinary approach should be taken for the application of the job plan. All technical fields which have related work in the areas to be studied should

be included in the study teams. This will give many different points of view for the study, which will create more ideas, and perhaps reveal areas of unnecessary costs. The experts in each technical field will better be able to determine impact of proposals concerning their portions of the project (52).

Team members should have some minimum training in the principles of VE. Types of VE training are discussed in a later section of this paper. Other beneficial attributes of the individual members of the team are that they be effective communicators, creative, and able to convert words and concepts into architectural and engineering solutions (52).

3.3 Information Phase

Once the areas of study have been selected and the team assembled, the facts must be established for the study areas. Thorough and complete knowledge of the current situation must be established, before new ideas and alternatives can be created. The amount of current information for a construction project will depend a great deal upon the progress of the design or construction.

Resources which should be collected are applicable design parameters, design specifications, flow diagrams, project schedules, and any drawings, if available. The data collected must be subdivided between facts and assumptions. Evaluations of the designs or assumptions are not the purpose of the information phase; gathering as much pertinent about the project is the goal (40).

The next part of the information phase is the heart of value analysis effort, and has been discussed in detail in the previous chapter. This, of course, is function analysis. Only after all the information about the project has been assembled can a complete function analysis be performed. The decision to continue the study can only be made after determining the functions, classifying them, and evaluating their value indices.

The determination of worth versus cost (value index) will determine whether there are potential benefits in the study, or if it should be terminated. Figures 3.1 shows the function analysis results from a recent VE study (37). The functions of the facility have been described by a verb/noun approach and classified as either basic or secondary. The value index has been calculated for each function to locate areas of high savings potential

The following list of questions will provide a good check on whether all the possible areas of information have been explored during the information phase (30).

Information Phase Checklist

1. Do you have all relevant background historical information?
2. Have you checked future use requirements?
3. What is the status of design?
4. What items are used on other designs?
5. Who has design approval authority?
6. Have you reviewed all specification and criteria requirements?
7. Did you double check for multiple-use items?
8. Have you listed high-cost items
9. Have you checked for unnecessary requirements and features?
10. Are there unnecessarily tight tolerances?
11. Have you checked for high-cost materials, labor, and construction methods?
12. Did you check for costly operation and maintenance?
13. Have you secured the best, up-to-date cost information available?

3.4 Speculative Phase

The key question for this phase of the job plan is: "What else will perform the

function?" The goal is to generate numerous different alternatives for accomplishment of the function. The key to the generation of alternatives is the individual and collective creativity of the the study group (30).

It has been hypothesized that all people are born with a definite and limited potential for creative work, and the limits of a person's creative potential can be realized through training and exercise (13). Figure 3.2 shows the creativity process for individuals. The figure shows that individual creativity peaks at the age of 4-5 years of age, and then declines as the effects of parents, education, and society begin to restrict and limit creative ability. The dashed loop that rises at the end of the chart demonstrates that creativity can be improved through training (13).

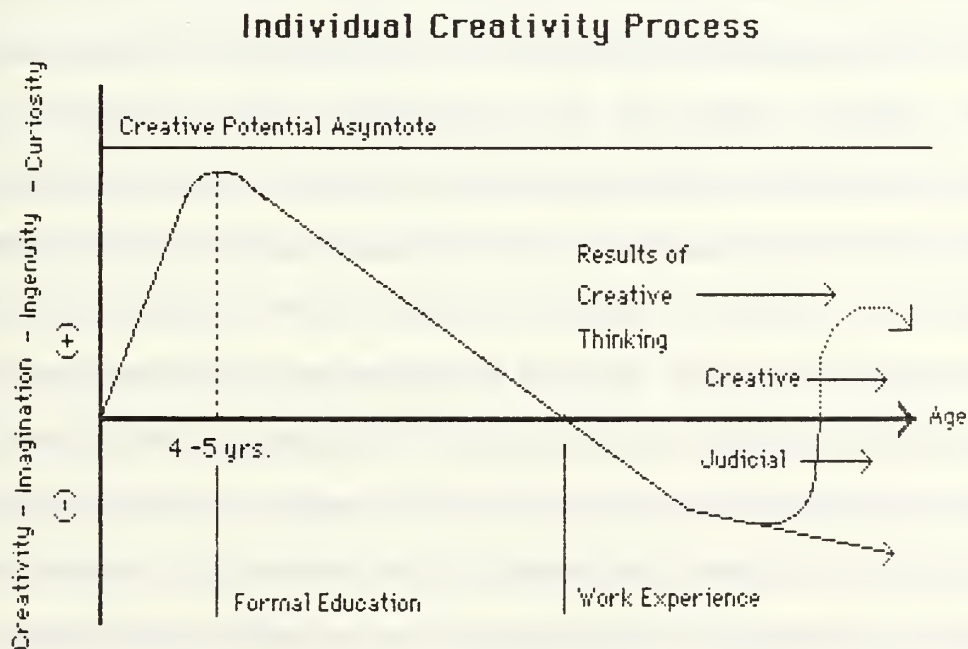

Figure 2.1 - Creativity Process

The proper environment must be established for the realization of creative

potential. Any negative factors affecting creativity should be eliminated, and encouragement should be given for creative efforts. Emotional blocks, such as fear of ridicule, must be eliminated. The following rules are helpful to keep in mind during creative idea generation (30):

1. Do not generate and judge ideas at the same time. Reserve judgement for later.
2. Do not discard any idea, no matter how impractical it seems at first.
3. Do not ridicule any ideas.
4. Watch for opportunities to combine ideas as they are generated.
5. Seek a wide variety of solutions, with many different angles of attack.

Several techniques are used for producing large numbers of solutions to problems. The two broad categories of techniques are: free association and organized (13). Free association techniques include brainstorming and the Gordon technique, while organized techniques include checklists, morphological analysis, and attribute listings.

Brainstorming is the leading technique for use in idea generation. Brainstorming is a conference technique where individual thinking is stimulated by the ideas contributed spontaneously by other members of the group. Research has shown that a collective group effort can produce 70% more ideas than individuals working alone (30). The typical procedure is a group of four to six people generating as many ideas as they can for solution of the problem, while judgement and evaluation of the solutions are not permitted. Final solutions are not usually the result of brainstorming sessions, but leads are produced which can point to a solution (30).

The ground rules for the session should be understood beforehand. Criticism is ruled out; all ideas should be welcomed. Free-wheeling should be encouraged, because wilder ideas tend to produce more angles for the solution. Quantity is desired because

this will increase the chances of finding the best solution. Combining ideas of others to produce new ideas can result in improvements to the original ideas (30).

The Gordon technique is a group conference method closely related to brainstorming. Free-flowing idea generation is encouraged similar to brainstorming, but the leader of the group is the only person who knows the exact nature of the problem to be solved (13). The subject which is discussed must be closely related to the problem to be solved, but the group must not be told the exact problem. When all group members know the exact problem to be solved, one member may conclude that he has offered the best solution sometime during the session. The acceptance of this solution may hinder the generation of new ideas, as this member attempts to defend and sell his idea. Instead of revealing the exact nature of the problem, the leader will ask the group questions or bring up subjects to discuss, which lead the group toward the solution of the actual problem. The exact nature of the problem can be revealed after the discussion has been concluded (30).

The second category of creative techniques is organized techniques. These techniques generate ideas to solve the problem at hand by following a logical step-by-step approach (30).

A checklist is an accumulation of idea clues, or leads, on a prepared list, which are useful for the subject under consideration. The objective is to obtain a number of ideas for further follow-up and development. Checklists can range in type from specialized to the extremely generalized (30). Although checklists may aid in the development of new ideas and remind the user of essential steps in a particular process, they may also tend to restrict original thinking.

Morphological analysis is a way to represent all the various combinations of parameters, which can be combined to solve a problem. The parameters must first be determined which define the problem, then these are represented in a model which

allows visualization of every possible solution. A problem which has two parameters could be modeled using a rectangular shape. For example, the windows for a building might be defined by two attributes: type and material. The horizontal axis could represent the types of windows (casement, double-hung, louvered, etc.), while the vertical axis could indicate the material used (wood, steel, aluminum, etc.). The rectangular grid would represent all the various combinations of the two parameters. Another parameter could be added with a third axis representing the type glazing. The resulting three-dimensional model would represent all the possible combinations for window selection. The group would then methodically evaluate all the various alternatives, until they found the best solution or solutions for their particular situation. Objects or problems with more than three parameters can be analyzed, but are difficult to represent on paper.

Attribute Listing is a creative method whose first step is to list all of the various characteristics or attributes of an object. The second step changes or modifies these characteristics. Using this technique, new combinations of attributes are brought together, which better fulfill the existing need (30).

It is not possible to cover all aspects of creativity and creative problem-solving techniques in this short presentation. Some of the most common techniques used in value engineering have been presented, but the selection of the technique for each specific application varies with the complexity of the study and the preference of the study team. The objective of the speculative phase is met if the team is able a number of possible solutions to be evaluated in the next phase of the study. Figure 3.3 shows a list of ideas created for the mechanical portion of a recent job (36).

3.5 Analysis Phase

After a list of alternatives has been generated during the speculation phase, the

CREATIVE PHASE

 Hanscomb Associates, Inc.

ITEM MECHANICAL
FUNCTION _____

This is the creative stage of the Value Study. Generate many ideas, processes or methods to fulfill function that the item under study must perform. Do not evaluate the ideas during this phase.

A
F.

Alternative

Change type of interior boxes & omit certain boxes

Relocate exhaust fans

- See A1.

Use roof top units

- See A & A1.

Eliminate AC to toilet

1.	
2.	
3.	
4.	
5.	
6.	
7.	
8.	
9.	
10.	
11.	
12.	
13.	
14.	
15.	
16.	
17.	
18.	
19.	
20.	

LIST EVERYTHING - JUDGE LATER

most promising alternatives must be selected for further analysis and refinement. Judgement of the alternatives was withheld to promote creativity during the speculation phase. The analysis phase seeks to critically examine these alternatives and rank them in order of descending savings potential (51).

The key questions to ask during the analysis phase are: What does each alternative cost? and Will each perform the basic function?(30) The alternatives are initially screened and the ones found to be impractical, to not meet owner requirements, or to be beyond the capability of current technology are dropped from the list. Combinations of alternatives are also formed, which further reduces the length of the list.

The remaining alternatives are further analyzed and listed with their potential advantages and disadvantages. Advantages could include light weight, reusability, or longer life expectancy, while disadvantages might be higher maintenance requirements, excessive construction time, or increased complexity of construction (13). Figure 3.4 shows a worksheet used on a recent job, which was used to evaluate the ideas generated for for a interior finishes portion of a recent project (37). The various advantages and disadvantages of each idea were listed, and the ideas were ranked on a scale of 1 to 10 by the team members. The ideas receiving low ratings (3 or less) were dropped from consideration.

Preliminary cost estimates are prepared for those alternatives whose advantages outweigh the disadvantages. Cost estimates must be as complete and accurate as possible in order to correctly rank the alternatives according to relative economic potential. Total costs must be considered, so that alternatives which have lower acquisition costs are automatically selected, without considering operational and maintenance costs. Acquisition costs are usually not difficult to determine, but more advanced life-cycle costing techniques are required to accurately determine costs for the life of the alternative (13). A creative idea evaluation form for a recent project with analysis of

Idea Evaluation

Creative Idea Listing

(1) NO.	(2) CREATIVE IDEA	(3) ADVANTAGES	(4) DISADVANTAGES	(5) IDEAL RATING
A-6	Reduce number of doors. Eliminate exterior access.	Reduced door costs	Reduced convenience of personnel	7
A-7	Use block partitions on 1st floor	May be more cost effective	Not as aesthetically pleasing; less future building	5
A-8	Run full height walls Eliminate sprinklers	Reduced sprinkler costs	Not cost effective	5
A-9	Use 5 1/2" Batt insulation in lieu of 2" rigid	Reduced exterior wall costs; increased insulation value	May not be cost effective	8
A-10	Review fire rating of corridors	May be possible to reduce construction costs	Would not comply with code	2
A-11	Use formica toilet partitions	Reduced partition costs	May not be cost effective on the life cycle basis	7
A-12	Eliminate corridor on 1st floor, decrease partitions	Reduced interior wall costs; more flexible layout	May not be acceptable	8
A-13	Use glazed GBU in lieu of ceramic tile	Reduced wall covering costs	Not as aesthetically pleasing	7
A-14	Use epoxy paint in lieu of ceramic tile	Possibly reduced initial costs	Increased maintenance cost	7
A-15	Reduced size of locker rooms	Consolidate excess space	Reduced convenience of personnel	See A-24

List all Creative Ideas before proceeding to judgement phase.
 10 Most Desirable
 1 Least Desirable

Figure 34 - Creative Idea Evaluation



arthur beard engineers

costs savings potential is shown in figure 3.5 (38)

Other aspects of the proposed alternatives must also be considered, which can not readily be assigned dollar values. These aspects often include aesthetics, durability, and saleability. Weighted evaluation techniques are discussed in a later section of this paper concerning management problem-solving. They provide the tools for complex decision making where there are several criteria, each with a varying degree of importance to the problem. One or more of the alternatives which are selected by the weighted evaluation procedure, and which present significant savings potential, are selected for further study and refinement in the development phase (13).

3.6 Development Phase

The alternatives which have survived the screening process in the analysis phase are developed into firm proposals during the development phase of the value engineering job plan. Detailed economic and technical data is gathered on the alternatives, as well as consideration of the probability of successful implementation. The alternatives are checked out with vendors, manufacturers, and other specialists in the field, costs are verified, and the ideas are reviewed for flaws or problem areas. This information is then used to support any recommendations for or against the respective alternatives. The key question for this phase is: Will the alternatives meet all necessary requirements? (30)

The proposals should include discussions of any objections likely to be raised concerning the proposals. If a technical objection looks to be likely, then ways to correct the deficiency should be explored, and if it can not be corrected, then the alternative should be dropped from consideration. Although full-scale testing is not a part of the value engineering process, limited testing may be conducted to establish the feasibility of an alternative (30).

The final outcome of this phase of the job plan is to recommend alternatives which have been determined to meet the necessary requirements and offer valid savings potential. It is common to have more than one recommendation to meet these criteria, but one of the alternatives must be the primary recommendation, and the others are presented as alternative choices in order of decreasing savings potential. A good checklist for the development phase would include the following questions (30):

1. Does each alternative provide the necessary performance requirements?
2. Are quality requirements met by each alternative?
3. Are reliability, maintainability, and operational requirements met?
4. Will waste of labor, material, or time be prevented?
5. Is each alternative compatible with the overall design?
6. Are safety requirements met by each alternative?
7. Have all supporting data been documented?
8. Has the first choice been selected?
9. Do the alternatives have an environmental effect?

Examples of alternatives which have been completely evaluated and developed into firm proposals are shown in Appendix A.

3.7 Presentation Phase

The objective of this phase of the value engineering job plan is to present the recommendations to those with the authority and responsibility to approve the proposals. The key questions to keep in mind during this phase are: What is recommended? and Who has to approve it? (30)

No matter how good the recommended alternative is, it will be of no value unless it

is accepted by management. Any recommendation will involve a change from the status quo, and any change will meet some roadblocks on the way to acceptance. The roadblocks may be technical in nature, or they may be purely personal or emotional. The presentation of the recommendations should have a strategy for dealing with these objections (40).

A sound proposal for management should be self-explanatory, and have factual and relevant information, so that there is no doubt concerning its justification. Supporting data such as test results or examples of previous successful applications should also be included. The following list of items should be included for a complete report (13):

1. Executive Brief - A brief description of the project studied and a brief summary of the problem and recommendations.
2. The results of the functional analysis, showing existing and proposed designs.
3. Sketches of before and after designs with changes clearly marked.
4. Technical data supporting the selection of alternatives.
5. Costs analyses of existing and proposed designs (Figure 3.6).
6. A summary statement listing the reasons for accepting the proposal, and any actions required for implementation.

3.8 Implementation and Followup

Once the value engineering recommendations have been accepted, they must be converted into actions. The costs of the study can not be offset until savings are realized by implementing the recommendations. The value engineering team should remain involved in order to resolve problems and clear up misconceptions in the implementation process. They should also ensure that the recommendations are not altered to such a degree that the cost-effectiveness is lost.

**VALUE ENGINEERING STUDY
 SUMMARY OF PROPOSALS**

PROP. NO.	DESCRIPTION	COST SAVINGS (PRESENT VALUE)						TOTAL LCC COST SAVINGS
		ORIGINAL DESIGN COST	PROPOSED DESIGN COST	INITIAL COST SAVINGS	ESTIMATED IMPLEMENT COST	O & M COST SAVINGS		
	<u>SITework</u>							
C-1	Reduce curb and gutter.	64,980	46,408	18,572	-	-	18,572 ¹	
C-2	Redesign parking lot.	446,909	408,994	35,915	(2,000)	-	33,915	
C-3	Reduce extent of storm drains.	32,776	15,583	17,193	(1,200)	-	15,993	
C-4	Reduce sidewalks.	27,959	18,349	9,610	-	-	9,610	
C-5	Reduce landscaping allowance.	26,000	13,000	13,000	-	-	13,000	
C-6	Omit drop-off area.	13,590	8,080	5,510	-	-	5,510 ¹	
C-7	Revise pavement specification.	366,250	245,603	120,647	-	-	120,647	
C-8	PVC drainage pipe in lieu cast iron.	11,190	3,809	7,381	-	-	7,381	
C-9	Use Class III in lieu of Class V pipe.	27,873	23,686	4,187	-	-	4,187	
C-10	Re-examine drainage pipe diameter.	DESIGN COMMENT						
C-12b	Redesign Sewage Treatment plant.	93,000	20,000	73,000	-	40,000	113,000 ¹	
	TOTAL INITIAL COST SAVINGS			207,933				
	TOTAL LIFE CYCLE COST SAVINGS				(3,200)	-	204,733	

Figure 36 - Summary of Proposals

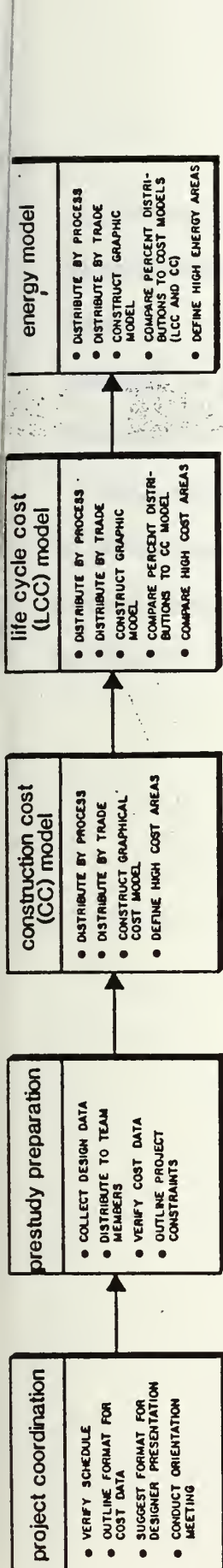

PROJECT STUDY PHASE

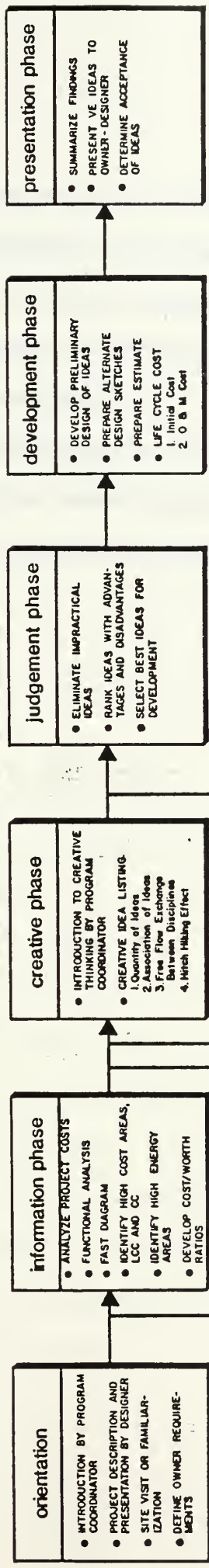

IMPLEMENTATION PHASE (POST STUDY PROCEDURES)

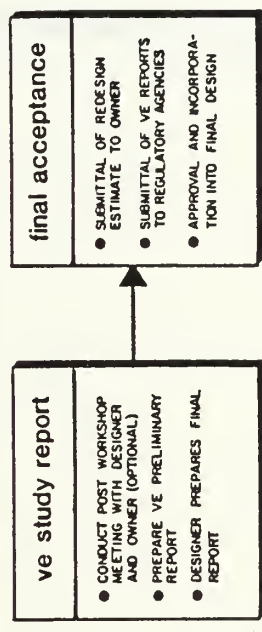

Figure 37 - VE Task Flow Diagram

Followup after implementation is intended to evaluate the effectiveness of the implemented recommendation. The results achieved in costs savings or performance should be compared with those planned and expected. The project should also be evaluated for any specific problems that occurred, so that corrective actions can be recommended for the next study (49).

Implementation and Followup represent the last phase of the VE job plan. Figure 3.7 shows graphically the various functions performed at each phase of the plan, and how each phase flows together with the others to produce implemented, cost saving, VE proposals (37).

Chapter 4

Value Engineering in the Construction Process

4.1 Introduction

In the majority of cases, cost is the predominant factor for construction projects. The owner may be building within a capital investment budget or for speculative purposes, but costs remain the primary concern. The construction process can vary a great deal according to the scope of the project, but as projects become larger and more complicated, the process from conception to completion takes a longer amount of time. The activity at the actual construction site is only a part of the overall process. What is less visible is the planning, budgeting, designing, estimating, scheduling, and other activities which must be done to complete a quality project within budget constraints and on schedule. Value engineering principles should be considered throughout all activities, if the best overall value is to be obtained for the project (40).

A typical project life cycle involves the following phases: concept-budget phase, programming, design, construction, operation and maintenance, and replacement. Value engineering has applications within all the phases, but the potential payoff for the VE effort varies throughout the process. Figure 4.1 shows a graph of savings potential versus cost to change. The graph indicates that savings potential drastically decreases during the later stages of the life cycle of the project, while costs to implement the changes increase. A breakeven point is indicated where the savings and costs meet. This point will vary for each project or item under study within a project. For example, the foundation for a structure will have an earlier breakeven point than the lighting system (33).

Potential for Savings and Breakeven Point

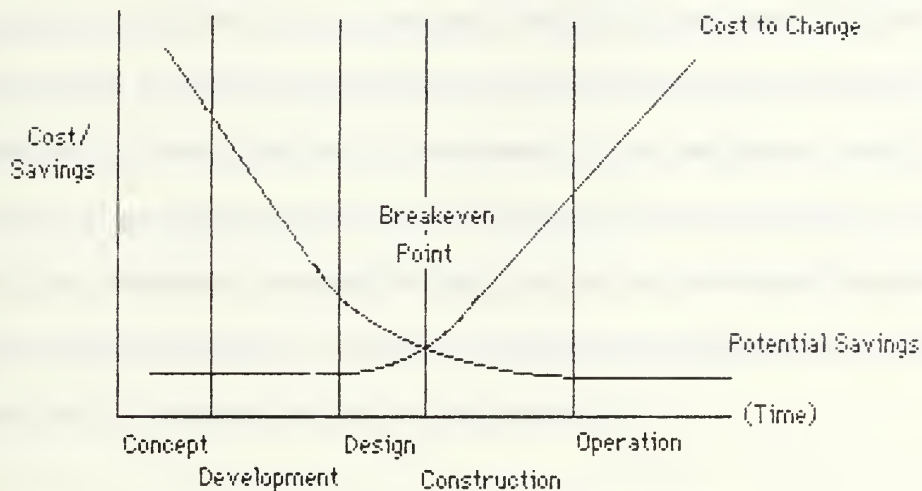

Figure 4.1 - Savings Potential Versus Cost to Change

Obviously value engineering has the greatest effect during the earlier stages of a project. However, VE can be applied at any stage of the life cycle where it is profitable to make changes for better value.

4.2 Budgeting and Programming

Since this is one of the earliest phases of the project cycle, budgeting can offer perhaps the greatest opportunity for value engineering. For most projects though, the design and construction agents do not have any involvement in this phase of the project. The development of a sound budget combines needs, cost, scheduling, and function. Costs for capital investments such as construction projects are normally spread over many years, therefore the tendency can be to invest in poor value because of inadequate analysis of the budget. Each budget item should be analyzed for value (40).

Value analysis in the conceptual or pre-budget phase should reflect a means by which the goals and objectives are to be attained. Taking the goals and objectives from the conceptual phase, the value analysis team can use VE techniques to come up with viable alternatives to meet them (40). Involvement of the design and construction professionals in the pre-budget phase can be beneficial for the preparation of viable alternatives. They provide the expertise for what can be done in terms of time and cost, so that realistic budget parameters can be set. VE questions which should be answered in the preparation of a building program budget include (3):

1. Are there any materials to be used that are in short supply?
2. Do any materials require a long lead time?
3. What is the labor climate?
4. Are wage increases expected during the life of the project?
5. Are contractors available to do the work?

The budget development phase is also concerned with financing strategy for the project. The financing strategy should be developed with the goal of maximizing the return on the building investment. The value engineer should work with the financial director in evaluating all considerations for a sound financing plan. A few factors to be considered are (3):

1. What would the cost of renting versus owning of comparable facilities be?
2. Are there any tax advantages that will accrue through owning?
3. What capitalization strategies will be most advantageous?

Programming occurs in the construction process after budgeting has been completed, but before design commences. Programming should spell out the owner's requirements, so that the designer has a framework within which to complete the design. Frequently this phase is omitted from the process, and the designer is left to undertake the task of detailing the program (40). The owner may think he is getting the programming without cost from the designer, but he is actually paying for it in extended design time.

The first stage of programming is the functional program. Functional program specifies the required spatial distribution and the relative locations of functions. An adjacency matrix or chart is one method of determining the required relative locations of functions. The importance of the proximity of the various functions to each other is indicated by a number value. Questions which should be asked by the value engineer during the process of assigning a number value to the co-location of two functions are (3):

1. Is existing space available where this function could be located?
2. Can some spaces be used for two functions?
3. Can some equipment be used on a time sharing basis?
4. Can the building be utilized effectively more than the normal 40-60 hours per week?

As with most areas of value analysis, the final product of the study is not as important as the thought process which produced it. In this case, the completed

adjacency chart is a good record of the desired relationships, but the process through which the rankings were made involved decisions on the importance or value in locating different functions in close proximity. A higher number ranking for two functions means that there is greater value in locating these two close together. Adjacency analysis can be done for any size functional group. For example, an overall industrial site may include activities such as manufacturing, storage, transportation, and administration. The relative locations for these can be analyzed for the best value using an adjacency chart such as the one in figure 4.2. Each of the large activities can also be broken down and analyzed individually. The optimum location of management, procurement, sales, and comptroller functions within the administration department is an example. Figure 4.3 shows an example adjacency matrix for an administration department.

The determination of the required spatial relationships is but one aspect of developing facility requirements during the programming phase. Figure 4.4 shows a simplified network of activities for developing the requirements (30). Performing the activities in the network will produce several concepts for the arrangement and locations of the various functions required for the building project. Many factors, physical features, and objectives are considered to produce the concepts for facility requirements. The various concepts which are produced by the network are evaluated for value using the techniques of the analysis phase of the VE job plan. Methods for decision-making, and choosing the best value alternative from a series of choices will be discussed in a later section of this paper.

Although the savings generated by value analysis efforts in the budgeting and programming phases are hard to quantify and document, they produce benefits that run throughout the life of the project. Value analysis in the early stages of a project

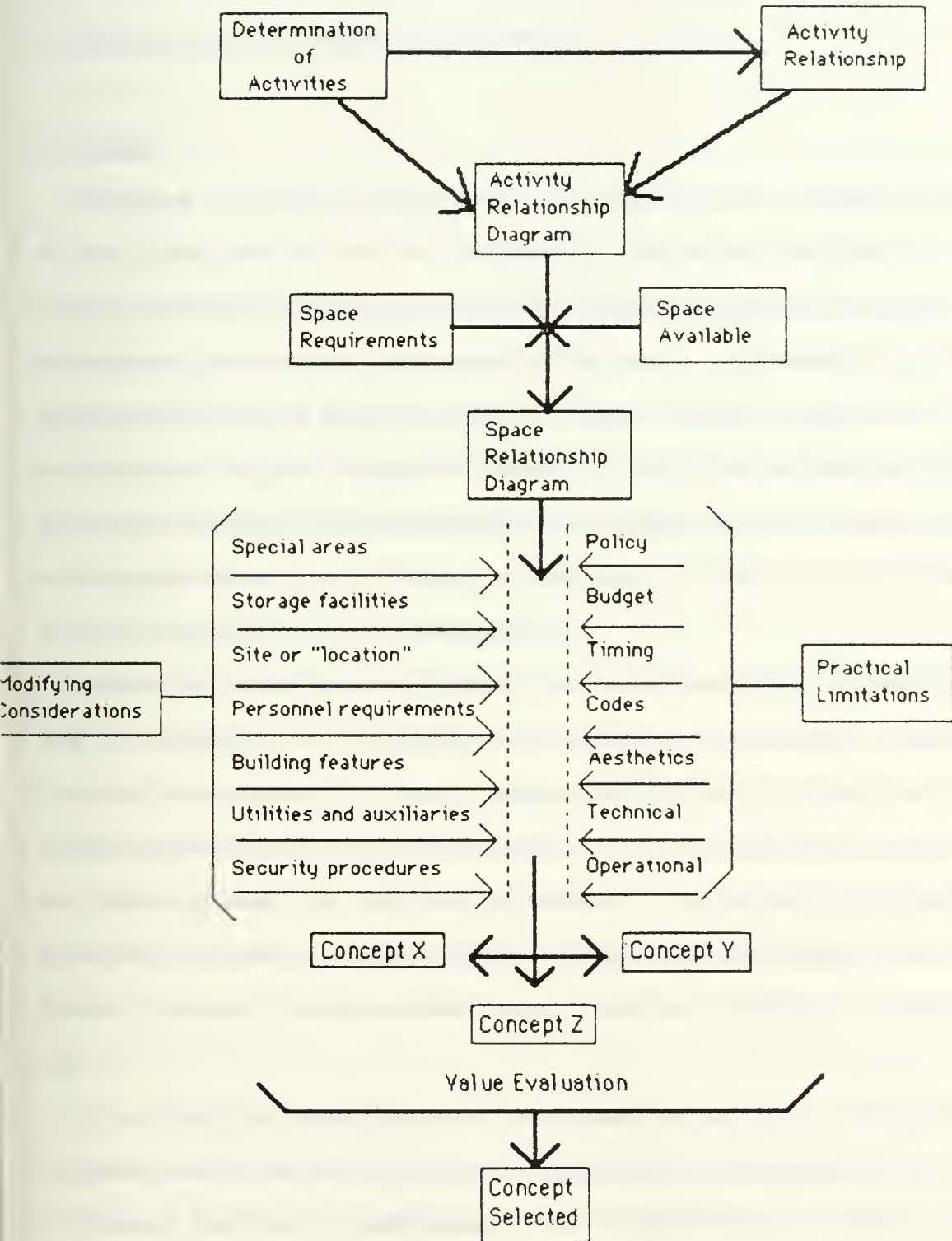

Figure 4.4 - Network for Developing Facility Requirements

aids economical decision making, and helps avoid unnecessary costs such as redesign from occurring in later stages of the project (30).

4.3 Design

Designing construction projects involves the participation of experts in many different fields, such as structural, architectural, mechanical, electrical, etc. The project is broken down into these areas and the individual designer develops plans and specifications that meet the requirements of the owner. For example the electrical engineer selects and designs the electrical system to meet the required loads, while the mechanical engineer designs the systems for heating and cooling the building. Occasionally economic studies are conducted for structural systems or energy systems, but normally the selection of systems or components are made by an individual or group of individuals within the same discipline.

Normally no formal job plan is followed, and no full-time employee is assigned the task of organizing and coordinating the activities of the separate disciplines. Therefore, design teams within each discipline conduct their own studies and make decisions based on the best economical choices, which provide the safety factors that are deemed necessary for their area of expertise. This system is not completely inadequate, but it does not produce optimum results for the overall design. The project becomes the object of suboptimization because subsystem optimization is emphasized (30).

To be effective in achieving overall optimization for the project, the individual disciplines must be made aware of how their decisions affect costs in other areas. These overlapping costs have a great impact on the overall cost of the facility. Value management emphasizes the need for a team effort in addressing and reducing these

overlapping costs (30).

The first step in the design process involves the development of the spatial solution. The requirements of the owner, along with the various zoning and building code regulations establish the parameters for design. Basic information regarding the site is important for the decisions regarding foundations, basement, and subbasement spaces. The various solutions which are deemed feasible should then be costed out. The lowest cost solution which would meet program requirements and building regulations is considered the worth cost. The costs per square foot of the various proposed solutions should be compared with the worth cost.

There is no single correct spatial solution, and each one has implications for other areas of the design, particularly structural. For example, the design of an office building may allow for 20 X 20 ft offices or bays, which would allow the use of interim columns. If total flexibility for future changes is required, then long-span beams might be the structure system required, which would involve higher unit costs. The best choice for structural system is not an automatic selection. The best solution varies according to cost of materials, geographical location of the project, trade practices, and the type of structure (40).

Value engineering for structural systems should take a realistic approach to savings by considering different factors for the different solutions. If reinforced concrete is the solution chosen, the designer may seek to save money in the amount of steel used by producing an intricate detailing of the reinforcing bar placement. This may indicate a savings, but if there is a variety of sizing and spacing of bars, then the designer would have to include a greater safety factor to cover mistakes during field installation. In addition, installation may be slower and therefore more expensive. The net result may be a system that is more expensive and takes longer to install (40).

Similar considerations should be made for structural steel systems. Some value engineering practices which can produce savings are the use of only standard structural sizes and shapes to reduce mill fabrication and waiting time, and the introduction of uniform modules of framing by the use of standard column sizes. Using higher grade strengths in the lower floors of a mid-to-high-rise building will cost more for material, but savings will be realized in reduced fabrication and erection times (40).

The exterior enclosure or skin of a building has functional, as well as aesthetic aspects to consider. One choice may be the amount of natural light to allow into the building. The psychological effects of natural light for the occupants of a building are substantial, yet the costs are high. In Washington, D.C. for example, the heat gain through a square foot of insulated brick and concrete block wall is estimated at 2.2 Btu/hr during the summer, while a double-plated glass wall in the same location will gain 173 Btu/hr (47). This eighty-fold increase results in a comparable increase in cooling-capacity required. Value engineering has resulted in the use of tinted, reflective, and insulated window treatments to overcome the psychological effects of a windowless building.

These types of analyses should be utilized in all the other areas of design. The selection of roofing, HVAC, electrical, and lighting systems are all affected by the spatial and structural solutions, yet different choices are always available. The key considerations for costs savings which run through all design details are (40):

1. Eliminating unnecessarily restrictive detail.
2. Ensuring standardization for details.
3. Minimizing the quantities of different types.

4. Eliminating unnecessary requirements.

5. Use specifications that incorporate labor-saving methods of installation.

4.4 Construction

The construction phase presents the last opportunity to reduce initial and life-cycle costs of the project. The systems and subsystems installed during this phase will, with few exceptions, remain throughout the life of the facility, so they firmly fix the future life-cycle costs (30). If value analysis techniques have been applied during the previous phases of the project, then the opportunities for more cost saving alternatives may be limited in the construction phase. However, there inevitably are some improvements for costs savings which could be made, so a final VE push during this phase can be beneficial (40).

Competition for jobs between construction contractors is keen, therefore contractors reduce profit margins to the minimum in order to win the award of contracts. Any opportunity to increase profits during the construction phase is welcomed. The contractor has better knowledge of the current state-of-the-art in construction practices, therefore he is in the position to suggest changes that reduce costs without sacrificing the quality of the design (30).

Value engineering changes during the construction phase can be categorized as either internal or external to the contractor's organization. An internal change is one that does not require deviation from or modifications to the plans and specifications, therefore no owner or architect approval is required. An internal value engineering change may provide the contractor with an advantage during the bidding process, if he can identify potential areas for savings in preparing his bid. The savings may be realized by the application of innovative construction techniques or by using

improved equipment or materials. The savings which are achieved help the contractor improve his profit margin, and some of the savings are passed on to the owner in the form of a lower bid price for the work (30).

Value engineering changes which require approval of the owner or architect are classified as external changes (40). These may be initiated by either the owner, architect, or contractor. Many contracts contain incentive clauses, whereby the contractor is compensated for value engineering efforts which save money for the owner. These are called value engineering incentive clauses (VEIC), and they specify the portion of the savings which will be awarded to the contractor. Government contracts distribute the savings on a 50/50 or 45/55 basis, while the savings distribution on private industry contracts may be up for negotiation. For changes which reduce operating and maintenance costs of a facility the contractor will typically receive 20-25% of an average one year's ownership savings (30).

The reimbursement to the contractor for value engineering changes is made after the approval and implementation of a value engineering change proposal (VECP). Before the advent of value engineering incentive clauses there was little or no financial incentive for a contractor to submit value engineering change proposals that saved money, as a result most changes relating to design factors were initiated by the owner or designer (40). In a fixed-price contract without savings sharing incentive clauses, the savings from changes would be deducted from the contract value. This meant a reduction in profit or fee to the contractor, and since general conditions and overhead were usually spread over the work-in-place items, the reduction meant a deduction in general conditions and overhead that contractor still had to supply (40). In a properly negotiated value engineering change order, both the owner and contractor should have the opportunity to profit.

A VECP should be prepared with sufficient information so that the owner-designer team can make a thorough review of the proposal without a delay to wait for more information. As a minimum the following information should be included in a VECP (18):

1. A description of the differences between the existing contract requirement and the proposed change, and the comparative advantages and disadvantages of each.
2. A listing and analysis of each contractual requirement which must be changed if the VECP is accepted, plus any recommendations the contractor may have for changing specifications.
3. A detailed cost estimate for both the old and proposed methods. The contractor must account for the estimated development and implementation costs, including any costs attributable to subcontractors. Also, the contractor must include a description and estimate of costs the owner may incur in implementing the VECP, such as test and evaluation as well as any changes in operating and support costs or procedures.
4. A prediction of the collateral cost saving or increase that the owner would experience if the VECP is implemented.
5. Identification of the time that a contract modification implementing the VECP must be issued in order to get maximum savings, plus any effect it will have on the delivery schedule or contract performance time.
6. Identification of any previous submissions of the VECP, including the dates and previous contracts. Previous acceptance set a precedent that may help subsequent approvals.

7. Identification of the item or task to which the VECP applies.
8. Statement that it is submitted in accordance with the VE incentive clause.

The VECP provides the best access for value engineering cost savings in the construction process. The contractor may apply traditional value-engineering techniques to develop proposals, or he may use any other informal techniques which produce cost savings proposals. In either event, the owner has the potential for saving money and the contractor for increasing profit, but greater potential exists where the contractor can use the creativity and analysis techniques of value-engineering methodology.

4.5 Study Team Procedures

A value engineering team study is the formal application of the job plan to a particular project. There is a tradeoff in the costs and benefits of when a project undergoes a value engineering study. If the study is started very early in the design phase, this improves the possibility of significant cost savings. On the other hand, changes early in the design are very difficult to evaluate for cost impact. If the study is conducted late in the design phase, the potential cost savings are easy to identify, but they may be reduced by the cost of redesign and delay of the project completion (13). Figure 4.5 shows the potential for life cycle savings that decisions have during the different phases of a project.

Relative Influence of Project Decisions on Life-Cycle Costs

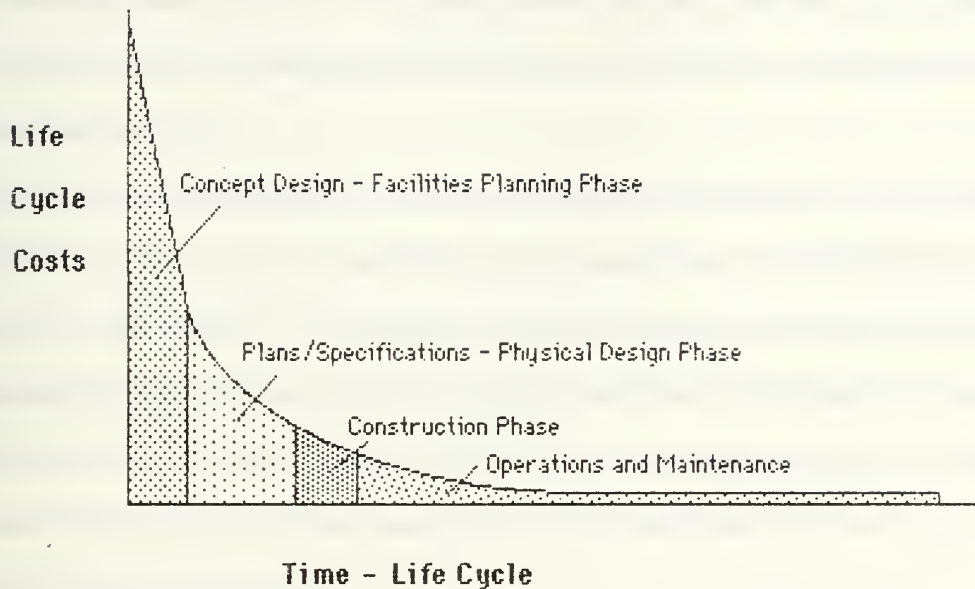

Figure 4.5 - Timing of Project Decisions

A phased approach to value engineering would be the ideal situation to optimize the costs versus benefits of implementing changes. A phased approach would involve separate studies at the early design stage, another study at the 50-60% design stage when the various systems have been identified, and a final study at the 90% design point to review the changes made to date and to make one last effort at eliminating unnecessary costs. In most projects only one study can be accommodated, and the optimum point for the best tradeoff of costs versus benefits to implement is at the 30-40% design stage (13).

The first step in performing a VE study is assembling the study team. The team should have a coordinator who is a certified professional value engineer. A professional value engineer is an individual who has been judged a Certified Value Specialist (CVS) by the Society of American Value Engineers (SAVE). It is important that the members of the study have not had any involvement in the design process, in

order to maintain objectivity (13). The coordinator may be a member of the owner or designer's staff, but best results have been obtained when the coordinator has been hired as a consultant (13).

The other team members may be in-house members of the owner's staff, members of the hired consultant's staff, or members of the design firm, provided that they were not involved in the design. It is desirable that the members have some training in value engineering methodology, but not necessary that they be certified. The members should have the same interdisciplinary skills which were used to produce the design. They should be experienced professionals in the various architectural and engineering fields involved in the design (13).

Proper preparation for the study usually dictates the amount of success the team will have for the project. The availability of the necessary materials and information about the project is critical to the success of the study. The following list of materials is considered essential (18):

1. Two sets of 30-40% full-size drawings.
2. Two copies of specifications.
3. Detailed cost estimates.
4. Basis of design.
5. Design calculations (mechanical, electrical, etc.)
6. Background reports (boring logs, soil reports, hydrological and weather data, etc.)
7. Photographs of the site.
8. Copies of any regulations, design, or criteria manuals.

Once the team and required information have been assembled, the formal value engineering workshop can begin. The team should be instructed in VE methodology and follow the job plan step-by-step to completion. The results of the study should be presented in a formal report which covers each recommendation and cost effects they will have for design, construction, and operation of the facility. The format of the report should make it easy for management to make prompt evaluation and decisions on implementation (13). Appendix A shows examples of proper format for submission of recommendations.

The size and complexity of the project indicates the amount of effort that is put into team studies. A large or complex project may call for multiple studies, while only one study may be necessary in a smaller project. The proposed level of effort should correspond to the potential savings which could result from the study. The following table represents a reasonable guide for the level of effort as it relates to project size (13):

<u>Estimated Construction Cost</u>	<u>Minumum VE Effort (Manweeks)</u>	<u>Maximum VE Effort (Manweeks)</u>
Under \$250,000	0	2
\$250,000-\$500,000	2	5
\$1,000,000	5	10
\$5,000,000	10	20
\$10,000,000	20	40
\$50,000,000	35	80

Table 4.1 - Recommended Levels of VE Effort

A reasonable goal to keep in mind when deciding on the level of effort to put into value engineering is at least a 10 to 1 savings to cost of study ratio (18).

4.6 Project Selection

Since the VE study process entails a certain amount of expense, the potential savings must justify the expense. Therefore, the process of selecting projects for VE study must recognize the need for change and the opportunity for savings within the projects. Promising projects for study are those which have one or more of the following characteristics (18):

1. Costs which substantially exceed initial estimates.
2. Complex items that provide costly or unnecessary functions.
3. Items which use critical or expensive materials.
4. Items which require very difficult construction or fabrication procedures.
5. Items which appear too costly to build, maintain, or both.
6. Designs which have been revised and become very complex.

Since most projects involve thousands of individual items, the identification of the ones which offer the best opportunity for savings through VE is an important step. A number of techniques are useful in the identification process, but it is beneficial to keep Pareto's law of distribution in mind. A graphical representation of the law (shown in figure 4.6) can be described in words by stating that a small number of elements (about 20%) account for the majority of costs (about 80%) in most facilities (18).

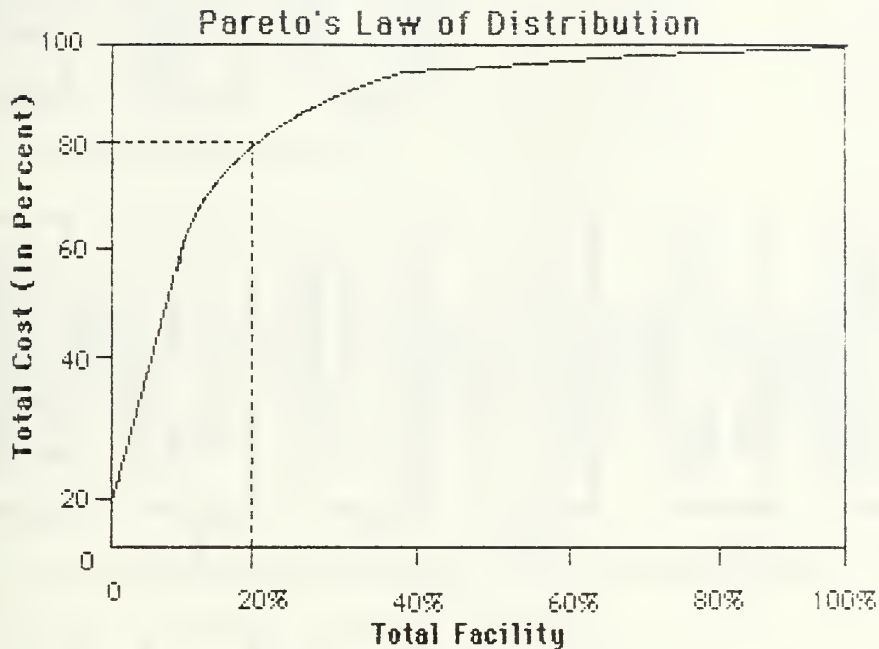

Figure 4.5 - Pareto's Law

4.6.1 Breakdown Analysis

One method for locating areas of highest potential for savings which utilizes Pareto's Law is breakdown analysis. This method makes a listing of all the various systems, subsystems, and special equipment for a project. They are ranked according to total cost per unit, so that a total distribution of expenditures for the project is shown. Those elements which represent the majority of expenditures for the project are selected. The items can be selected by going down the list until approximately 80% of the total cost for the project is reached, and then taking those items selected for more in-depth analysis. This is a very unsophisticated method, but may be appropriate for a first-cut approach. What the approach is lacking is the comparison of cost to some yardstick such as worth (13).

A graphical representation of the breakdown of costs for a project can be beneficial in quickly spotting areas of high cost. Figure 4.7 is a simple cost breakdown

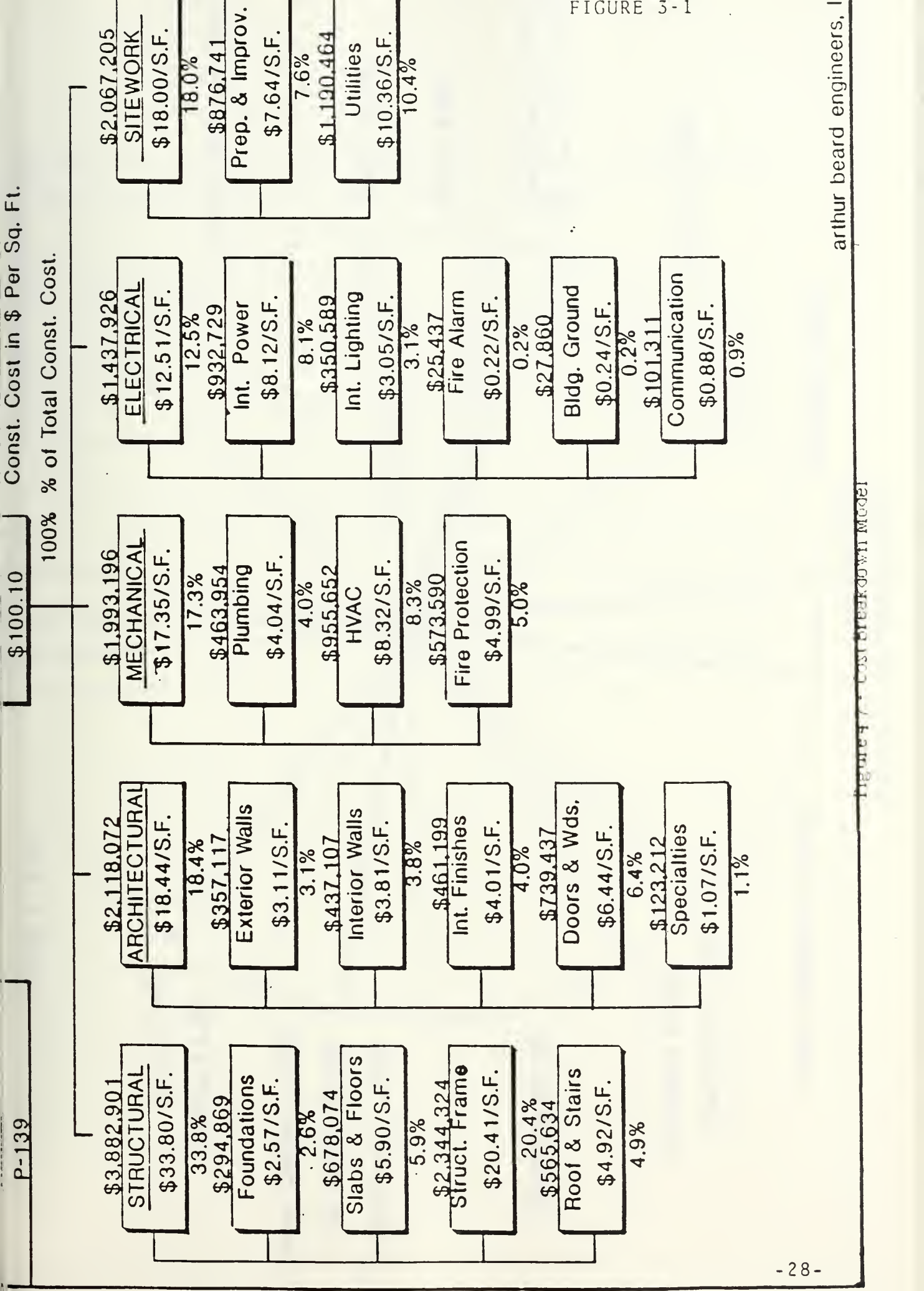

FIGURE 3-1

arthur beard engineers, l

Figure 7 - Cost Breakdown Model

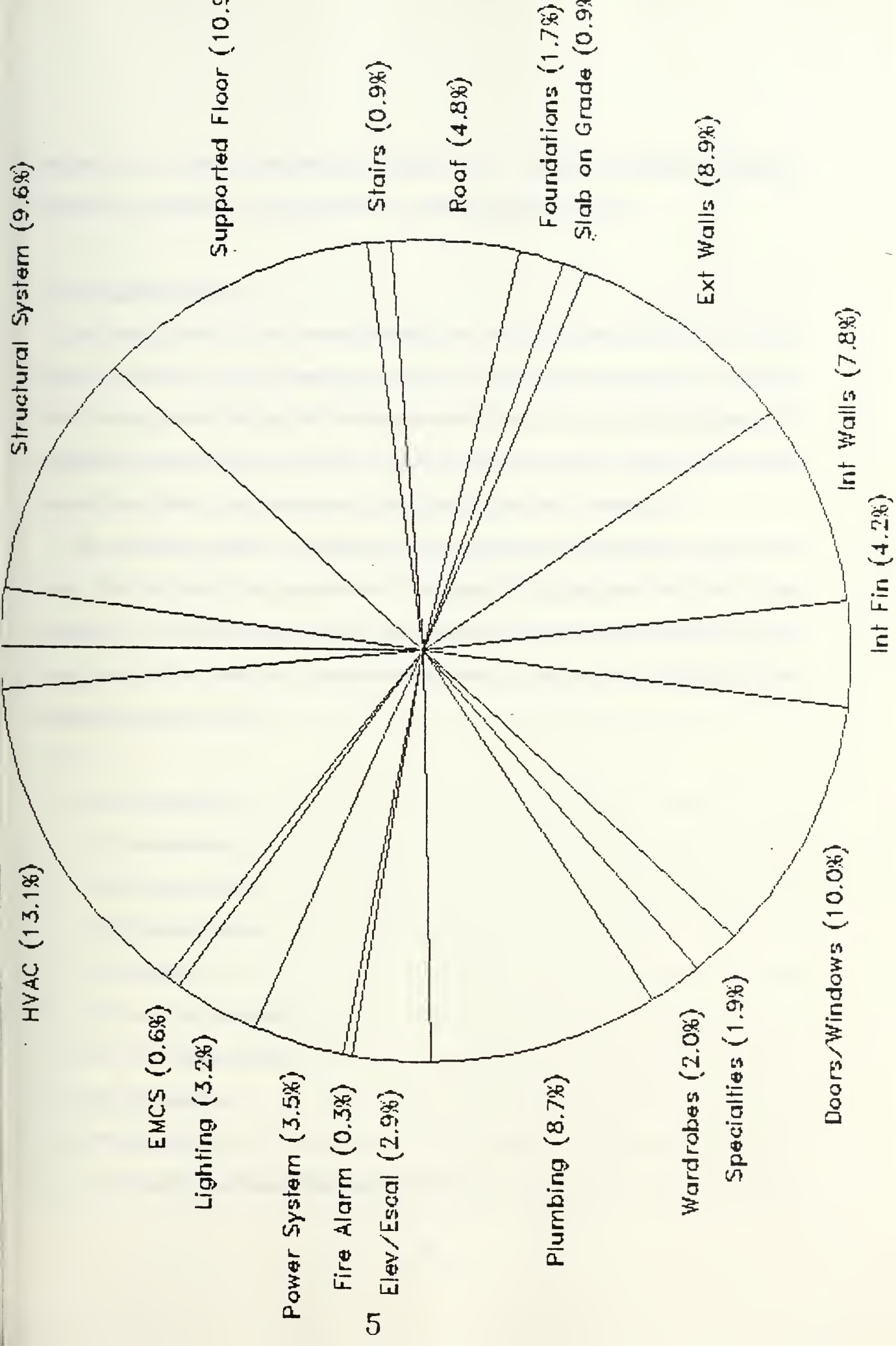

Figure 4-8 - Cost Breakdown Model

daigram for a Aircraft Maintenance Hangar (37). Figure 4.8 shows a different graphical presentation of cost breakdown, utilizing a pie chart (38).

4.6.2 Cost/Worth Model

The identification of the lowest possible cost for a particular function, or "true" worth, is difficult if not impossible to achieve. What can be identified is a "target" worth, which can be defined as the lowest attainable cost to perform the function. The estimated function costs can then be compared with the targets, in order to determine areas of poor value. The comparison is facilitated by the use of a model (4).

The cost/worth model is a diagrammatic technique to easily identify areas of poor value. The first step in the preparation of the model is the functional breakdown of the project (4). The model should reflect the functional requirements broken down into major construction trades with appropriate supporting subgroups. A listing of typical breakdown groups is (13):

- 01 Foundations
- 02 Substructure
- 03 Superstructure
- 04 Exterior Closure
- 05 Roofing
- 06 Interior Construction
- 07 Conveying Systems
- 08 Mechanical
- 09 Electrical
- 10 General Conditions Overhead and Profit

11 Equipment

12 Site Work

An example of subgroups supporting one of the above major functional categories is partitions, interior finishes, and specialties, which are sub-groups of interior construction. The cost account structure with twelve categories shown was developed by the General Services Administration in conjunction with the American Institute of Architects and is named UNIFORMAT (16). Another common system is the Uniform Construction Index (UCI) which has sixteen categories.

The functional categories and sub-groups are diagrammed by boxes connected in a hierarchy. The top of the hierarchy should be a box labeled total project or total construction costs. In a typical model each box in the hierarchy has a solid and a dashed portion. The target costs for each breakdown area are put in the solid box, while the costs from the designer's construction cost estimate are placed in the dashed portion.

The target costs for each area represent the worth of the function. The cost targets are the result of expert judgements based on experience with similar projects, historical cost data, or previous study results. An effort to formalize the target cost determination has been led by the General Services Administration (GSA). The GSA has developed "Cost Adjustment Guidelines" which give standard unit costs for each functional area of the project along with a chart that gives various adjustment factors for the base cost (16). For example, The base cost guideline for foundations is \$2.11 per building footprint area. This cost assumes: a 3 foot frost line, 3000 PSI concrete, excavation, backfill, and foundation walls or column piers. The figure is then adjusted for various soil bearing capacities, total load per floor, number of floors, and bay size

requirements. A two-story building, with 1500 SF bays, 10,000 PSF total load, and 10,000 PSF soil bearing capacity has a factor of 0.38. Therefore, the target cost for this functional area would be $(0.38) \times \$2.11 = \0.80 per SF footprint area. The method is certainly not fool-proof, so professional judgement should be used to make any other adjustments to the target costs as deemed necessary (16).

These target costs are added up to produce a "Basic Cost Model" (13). The estimated costs are compared with the model, and the areas where the estimate differs the greatest from the target are selected for VE study. The model provides a means for readily identifying the areas where these differences exist. An example of a completed cost model for an actual project is shown in figure 4.9.

4.6.3 Life Cycle Cost Model

Cost/Worth model analysis is a method which looks at only the initial cost of a project. With the advent of the energy crisis and increasing interest rates it has been increasingly important to consider future costs as well. No longer can an owner afford to pay the minimum cost to get into a building, without considering the future costs (52). Life cycle costing is an economic analysis technique which considers all the costs of ownership for the life of the project. The owning, operating and maintenance costs are considered, along with the salvage value at the end of item's life expectancy. The key to accurate evaluation is that all cost must be compared as equivalent dollars, so economic formulas are used to bring the figures back to a baseline reference year (13).

The term *discounting* is commonly used to describe the process of using mathematical formulas for economic analysis. Factors such as time, interest, present costs, future costs, and annual costs are equated so that costs on any given time can be expressed on an equivalent basis (51). A list of typical life-cycle costs to consider on

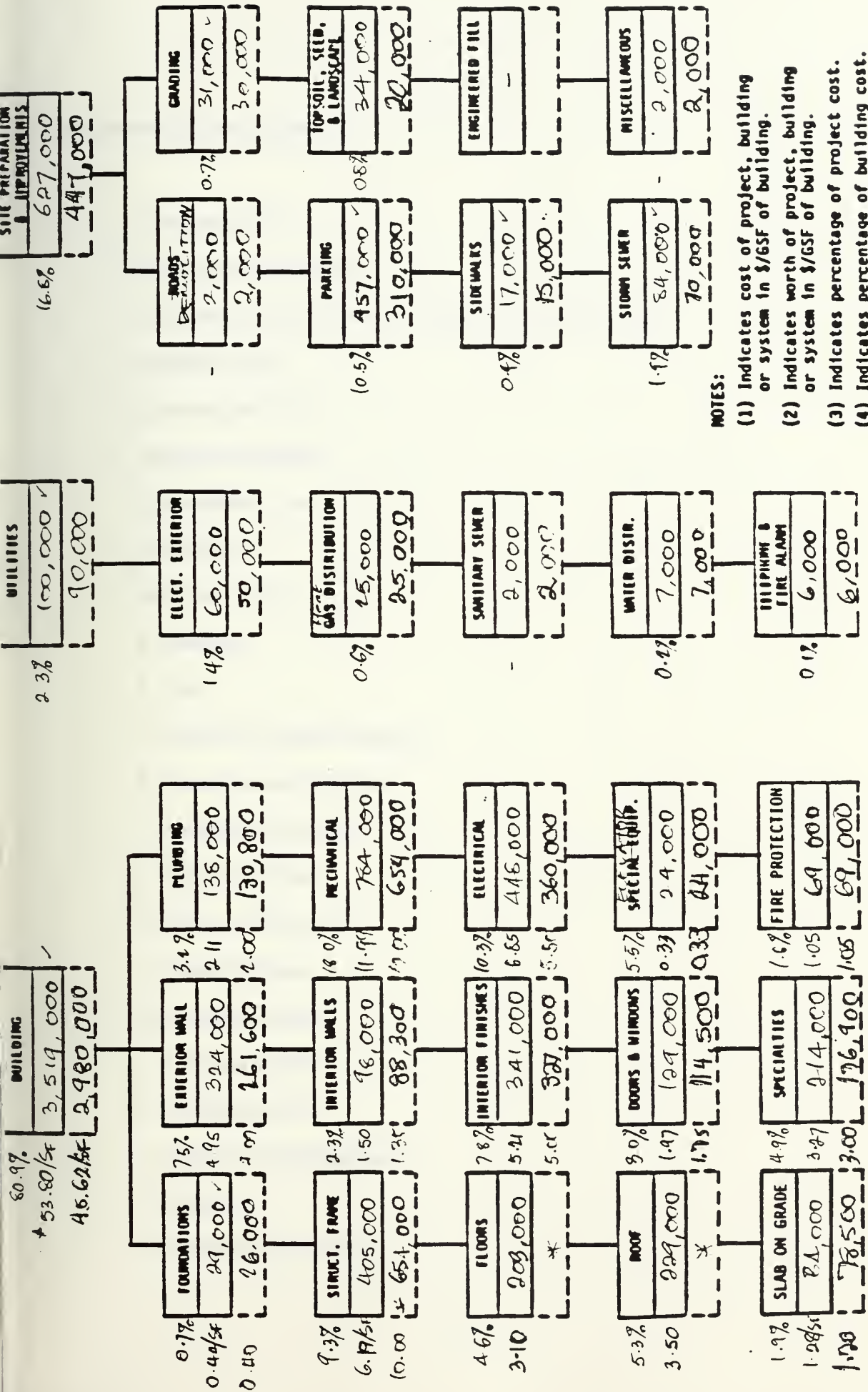

NOTES:

- (1) Indicates cost of project, building or system in \$/GSF of building.
- (2) Indicates worth of project, building or system in \$/GSF of building.
- (3) Indicates percentage of project cost.
- (4) Indicates percentage of building cost.
- (5) Indicates cost to worth ratio of system.

Figure 4.9 - Cost/Worth Model

most projects is given below (52):

1. Investment Cost
2. Land Acquisition Costs
3. Engineering Cost (Planning, Design, and Construction)
4. Redesign Costs
5. Construction Costs
6. Administrative Costs
7. Replacement Costs
8. Salvage Costs
9. Operating Costs
 - a. Staffing
 - b. Fuel
 - c. Electricity/Demand Charge
 - d. Chemicals and Supplies
 - e. Operating Schedules
 - f. Outside Services
 - g. Resource Recovery
 - h. Transportation
10. Maintenance Costs
 - a. Lubricants/Parts
 - b. Staffing/Labor
 - c. Preventative Maintenance
 - d. Cleaning
 - e. Durability of Products

11. Time Cost of Money

The estimates for life cycle costs are calculated and compared with target figures in a diagram similar to the cost/worth model. Once again, the items or functional areas which have estimates that significantly differ from the target figures are selected for in-depth study. In many instances, the data for setting target figures for maintenance, operation, and replacement is insufficient or very difficult to obtain. This may make the life cycle costing model too time-consuming and unproductive to develop (13).

CHAPTER 5

VE APPLICATIONS FOR CONSTRUCTION MANAGERS

5.1 Problem Solving

5.1.1 Introduction

The success of a construction organization or project depends on the problem solving and decision making ability of managers. Successful managers must make decisions as good or better than the competition. All managers use some type of system to solve problems and make decisions, but rarely is a formal methodology followed. Usually the pressure of time in the project environment forces managers to make quick decisions, relying on intuition or past experience, and quite frequently the best solution decision is not made (30).

The typical project environment has people from many different areas exerting pressure on the construction manager to take some action. The pressure may come from top management of the company, the owner of the project, field personnel, or subcontractors. To further aggravate the situation the manager may not have all the information about what the problem is and its cause to make a correct decision. Typically the manager is not as knowledgeable on the technical details of the project as the people who he manages. What the manager needs is a systematic and logical method for gathering the information and solving the problems. Value engineering methodology can be used by managers to solve problems and make critical decisions.

Problems arise when there is a deviation from what is desired. Figure 5.1 shows the nature of a problem (30). The deviation is something that is undesired, and it must be corrected in order to attain the desired objective. In construction management the deviation could be in several forms, such as costs running higher than targets or work progress not conforming to schedule. successful problem solving involves identifying

the deviation or problem, finding its cause, and deciding on the corrective action to take (30).

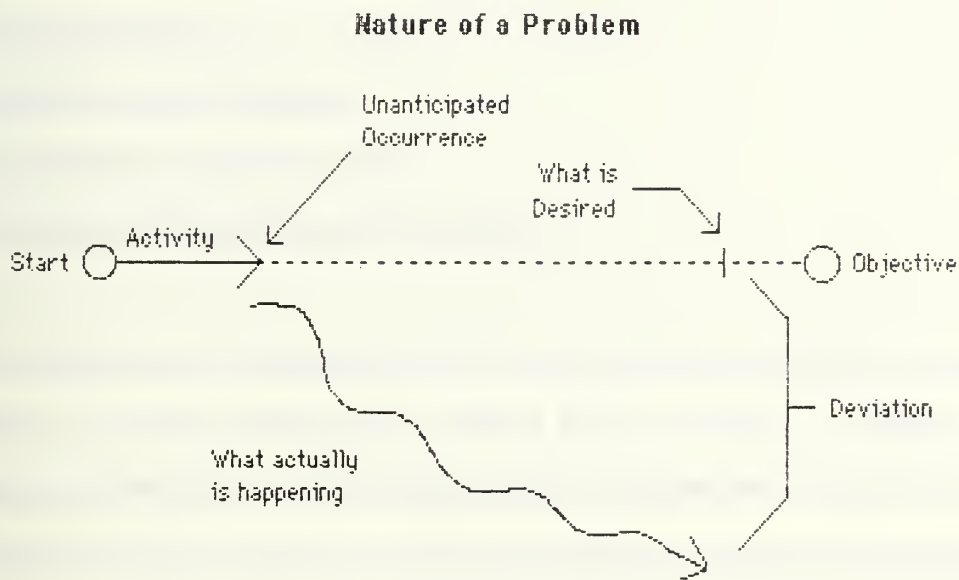

Figure 5.1 - Nature of a Problem

5.1.2 Systematic Approach

Value engineering methodology can be modified to be used as a systematic approach to problem solving. By narrowing down the available information about a problem in a systematic manner, the various causes and possible solutions are identified. These solutions can then be judged and tested to find the best one for the particular situation. The phases of value engineering methodology (information, speculation, analysis, development, presentation, implementation and followup) are modified to produce the following steps of systematic problem solving (30):

1. Recognize the problem.
2. Specify the problem.

3. Develop possible causes.
4. Test and determine the true cause.
5. Develop solutions to the cause.
6. Test the solutions
7. Decide on the best solution.
8. Implement the solution chosen.
9. Evaluate the effectiveness of the solution.

The major obstacle in problem solving is knowing what the problem is. It has been stated that a problem well-defined is already half solved (22). In many instances symptoms are solved instead of the actual problem. To precisely recognize and specify any problem during a construction project the following questions should be answered (30):

1. What is the deviation? What is the thing or activity in which the deviation is observed?
2. Where is the deviation? Where is the thing or activity when the deviation is observed, or where in the building process is the deviation observed?
3. When does the deviation appear?
4. How big or what is the extent of the deviation? How many different things or different activities are affected by the same deviation?

One key point to note here is that in none of the questions is the word "why". "Why?" indicates speculation which is part of another step in the approach, and not part of recognition and specification of the problem. It is important to not bring in any thoughts which divert attention from only identifying the problem during this

phase (30).

Finding the cause of the deviation producing the problem is made easier after the problem has been defined in the previous step. The answers to the where and when questions point out the areas where the manager can concentrate his efforts in searching for the cause. The Functional Analysis System Technique (FAST), which was discussed in a previous section, is another helpful tool in searching for cause. The why and how questions asked about a series of functions can lead to the cause of the functions not being executed as expected. If the technique is used properly it will show the cause and effect of the functions as they are designed to work. This may help point out why the desired result is not happening. Problems are caused by a change from the desired, and FAST can help clarify the desired performance.

Once an area of the work has been identified as a possible cause of the problem, the manager needs to test this hypothesis. If it is suspected that the cause of the problem is material in nature, then a test of the material should be performed. If the design is suspected as being faulty, different methods should be tried if feasible. Personnel or work methods can be changed or monitored, if they are suspected as the cause. No matter what the cause is, it will be easier to find if the problem is clearly identified to begin with (30).

Developing solutions to the problem relates directly to the creative or speculation phase of the VE job plan. Techniques such as brainstorming and the Gordon technique are helpful in generating possible solutions. The result of this step is a list of possible solutions, which then must be evaluated against each other to find the best one.

The analysis of a series of alternatives is one example of decision making for a manager. A manager is required to make important decisions on a daily basis, which affect the success of his company or project. Some decisions are of the "yes-no" or "either-or" nature. While these are not to be taken lightly, the tougher decisions are

the ones which require the choice of the best out of a series of alternatives. Each alternative presents a series of tradeoffs between economic and non-economic criteria. In addition, each of the criteria has a relative importance compared to the others (13). There are several techniques for evaluating different alternatives against various criteria.

5.1.3 Weighted Criteria Evaluation

It is recognized that there is an unlimited number of possible valid criteria depending on the particular project or situation, but a good starting point for most projects is the following five criteria:

1. Contribution to the objective. What is the alternative's usefulness for solving the problem?
2. Feasibility. Is the proposed solution likely to be successful?
3. Undesirable side effects. Does the solution worsen the situation in any way?
4. Time. Will the solution be able to be implemented in time to meet the demands of the situation?
5. Costs. What will it cost, and what will it save?

Not all problems will have all these criteria, and most will contain additional criteria.

Once a sufficient number of criteria have been identified, they are divided into primary and secondary criteria. Primary criteria are those characteristics crucial to achieving the objective of the system or project. Secondary criteria are not crucial for achieving the objective, but they are attributes which you would like to have (17). Primary criteria are used to initially screen the alternative solutions to the problem. If an alternative does not meet the primary criteria, then it has no value for a solution to

the problem (17). The secondary criteria are then used to make the decision on alternatives which meet the primary criteria. As an example, the primary criterion for purchasing a house might be: three bedrooms, two bathrooms, a kitchen, and family room. There are many alternatives which would satisfy these criteria. Secondary criteria which might be used to decide between the alternatives meeting the primary criteria are: size of yard, location, age, and garage.

Frequently not all of the secondary criteria are considered of equal importance. A subjective value or weight can be assigned to each criterion to reflect how important they are relative to one another. Figure 5.2 shows a useful form for relative weighting of criteria (13). The first step in weighting the criteria is determining the most important ones. The criteria selected are then listed and given a letter identifier. The grid is used to compare each criterion against all others, and rank the relative preference. The letter of the criteria determined to be more important is entered into the box along with the degree of preference. If no difference in importance is perceived between the two criteria being compared, then both letters are entered in the box with each receiving a score of "1".

The total preference points given to each criterion are totaled and entered in the raw score line on the upper portion of the form. In order to standardize the weighting procedure, the top raw score is given a score of "10", and the other scores are weighted from "1" to "10" depending on their raw scores (13).

Figure 5.3 is a decision grid or matrix, which can be used in comparing alternatives using the weighted criteria (17). The first step is to list the primary or limiting criteria on the lower right-hand portion of the form. The various alternatives which meet the primary criteria are then listed in the idea column. The alternative of doing nothing, or maintaining the status quo, is always an option and is listed at the bottom for a benchmark (17).

Project		Item	
Team	Criteria	Date	Weight
			Raw Score
A.			
B.			
C.			
D.			
E.			
F.			
G.			
H.			
I.			

Criteria Scoring Matrix

	B	C	D	E	F	G	H	I
A								
B								
C								
D								
E								
F								
G								
H								

How Important
 4 - Major Preference
 3 - Medium Preference
 2 - Minor Preference
 1 - Slight, No Preference

Figure 5.2 - Decision Criteria Weighting Chart

The secondary or decision criteria are filled in the top portion of the grid. Only those which were ranked highly during the weighting process should be used in the decision grid. In addition, criteria which are fulfilled equally well by all alternatives should not be included (17).

The legend in the lower left-hand corner of the form is used to score the alternatives. A value of "0" to "3" is assigned according to how well each alternative fulfills the criteria. A value of "3" means that the alternative completely fulfills the criterion, while a "0" means it does not meet the criterion. This score is put in the upper portion of the box corresponding to the specific alternative and criterion. The score is multiplied by the weight of the criterion and entered in the lower half of the box. The process is repeated until all alternatives have been scored against all criteria. The weighted scores are totalled and entered in the last column for each alternative. The alternative receiving the highest total score represents the proposed solution with the most potential for solving the problem given the criteria chosen.

The scores should be ranked according to score, in order to show the magnitude of difference between them. Frequently the top two or three scores are rather close together, indicating small differences. Sometimes the second or third ranked alternative, if close in rank to the first, can be chosen based on a subjective reaction (17).

5.1.4 Tradeoff Evaluation Process

Another method of decision-making which can be used for everyday management decisions or during the analysis phase of value engineering is the Tradeoff Evaluation Process (TEP). TEP involves three central activities for choosing between two or more alternatives (49):

Decision Grid / Matrix

Ideas	Decision Criteria							Totals
	Weighting Factors							
Do Nothing								

Scoring:

- 3 Completely fulfills criterion
- 2 Basically meets criterion
- 1 Marginally meets criterion
- 0 Does not meet criterion
- / Criterion does not apply

Constraints (limiting criteria)

1. _____
2. _____
3. _____
4. _____
5. _____
6. _____

Figure 5.3 - Decision Grid

1. Decide the advantages of each alternative.
2. Decide the importance of each advantage.
3. Select the preferred alternative.

The major difference between TEP and Weighted Criteria Evaluation is that TEP weighs the importance of specific differences between alternatives, rather than weighing factors of criteria. An advantage is defined as a favorable difference between two alternatives (49).

The advantages of each alternative are determined by first deciding the quality or quantity factors that are considered important. Where differences in factors exist between the two alternatives, an advantage is identified for the alternative which performs better for each factor. Factors which are met equally well by both alternative will not affect the decision (49).

The importance of each advantage is decided by first choosing the most important advantage. This *paramount* advantage is identified by evaluating advantages not factors (49). If the items being studied were microwave ovens and the two factors being compared were microwave leakage versus appearance, most people would choose leakage as the most important factor because of safety reasons. If the difference in leakage between the alternative ovens is small, not enough to affect health, then the leakage may not be as important of an advantage as appearance. This illustrates the difference in ranking advantages and not factors.

The *paramount* advantage is given a importance of "10.0", which establishes the scale of "1.0" to "10.0" for the other advantages. Each advantages should be given an importance within this scale based on analysis of interdisciplinary factors, market studies, uncertainties and risk, or other subjective factors (49).

The final step is to total the importance of the advantages for each alternative and

choose the alternative with the greatest total. An illustration of the final tradeoff display for a microwave oven selection is shown in figure 5.4.

MICROWAVE OVEN SELECTION TRADEOFF DISPLAY

Advantages of A	Advantages of B
1. Automatic hold to aid defrosting.	1. B has 0.3 more cubic feet in space than A.
Importance: 2.5	Importance: 3.5
2. Sturdier cabinet with slightly less chance of leakage.	2. Alternative B is much more attractive than A.
Importance: 1.5	Importance: 10.0
3. A has 50 watts more power.	
Importance: 6.0	
	=====
Total Importance of Advantages	10.0
	=====
	13.5

Figure 5.4 - Microwave Oven Selection Example

TEP is a method of decisionmaking which is very easy to use for a wide variety of decisions. The advantage it has over other methods is that it is less complex but still visibly presents the results (49).

5.2 Procurement

A significant responsibility of the construction manager is to locate the vendors and subcontractors whose products and services will meet the requirements of the project at the lowest price. Value analysis and efficient purchasing mutually enhance the performances of each other. Value analysis techniques can be used to make procurement more cost effective, while efficient procurement is the means by which much of the value analysis effort is implemented.

Procurement personnel function at the point of transfer of company money for materials, products, and services. They often have the best opportunity to observe whether or not the company is obtaining good value on particular items. The achievement of the goal of obtaining maximum value for expenditures can be aided by the use of value analysis techniques (51).

The value analysis technique applied to procurement stresses the purchase of functions (32). The purchaser should concentrate on what the item or service does for the job. The function or usefulness is then related directly with what it is costing. Functions are further studied and clarified in a manner that will produce better value alternatives. The cost-saving alternatives should be reviewed by technical experts to insure that they are practical, usable, and acceptable from a technical viewpoint. The evaluation of function by procurement personnel can lead to the purchase of materials or services which are entirely different from what was originally intended to be procured, but which fulfill the desired function with better value.

Value analysis techniques discussed in earlier sections of this report such as weighted criteria decision making and tradeoff evaluation process are means to choose the best value of materials and services to be procured. The basic function must be fulfilled by all alternatives, but the decision among those that meet the basic function may be affected by many other criteria or advantages. These criteria may include

supplier reputation, timeliness of service, or warranties.

5.3 Cost Control

Value analysis techniques can be used to maximize the effectiveness of the cost control functions of a construction manager. Most companies have some type of cost control system, which includes a reporting system to monitor accumulated costs and report them back to management for evaluation and any corrective action. VE techniques can be used find cost effective corrective actions.

The existing cost reporting system can be seen as performing the same function as the various cost modeling techniques used during VE studies. The cost reporting system identifies areas where costs are highest in the job and areas where the actual costs are exceeding what was estimated. Therefore, the cost reporting system is used to point out the areas with the best potential for savings.

Formal VE methodology can be performed for the items or areas of work which are identified as not conforming to cost targets. Creative solution generation techniques, analysis and development of alternatives, and systematic decision making methods can be used to choose the best corrective action for the project.

The critical time-table for most jobs would limit the time available for deciding on corrective actions. A full VE study would probably not be feasible, but by applying the techniques informally or in a shorter format, the attainment of successful cost saving solutions will be aided.

CHAPTER 6

VALUE ENGINEERING STATE OF THE ART

6.1 Current Industry Practice

Techniques for productivity improvements in the construction industry have generally followed the lead of other industries. Value engineering is an example of this, because it was first developed and refined in the manufacturing sector of the economy (2). The successes of VE in manufacturing led to its adoption by federal construction agencies, and the technique eventually spread into the construction industry as a whole.

For the most part, VE has been accepted into the construction industry without much modification. However, the construction industry has several characteristics which differ from the manufacturing sector. Some of the differences are (2):

1. Design and construction processes are separated.
2. Production is customized, each project is a unique production of materials, systems, and components.
3. Project teams (owners, designers, contractors) are usually assembled for only one job and rarely have the opportunity to work together from one project to another.
4. Contractors are under-capitalized so that they can remain flexible in the face of uncertain markets, cyclical volume, differing project requirements, and fixed project locations.

VE principles applied throughout the construction process could help to bring some discipline and logical thinking to every step in the process. Typically however, VE

principles are called upon only for a single workshop study at the 25%-35% design stage, or when an owner or architect realizes his project is in deep financial trouble and seeks help.

The VE job plan is commonly applied to a project by employing a VE team study at the conceptual design stage of the project. The team study workshop is usually 40-hours in duration, and, when well managed, has produced some excellent results. The workshop technique has a number of drawbacks for construction applications (2):

1. It is difficult to assemble the key participants for such an extended period and maintain their undivided attention.
2. Most participants are uneducated in the VE process, and therefore, much of the session is spent learning the techniques.
3. Evaluation and development of alternatives is difficult to accomplish in the time allotted, because intensive design and engineering analysis is frequently required.
4. VE proposals are frequently not implemented properly and are isolated from project cost management.
5. It is difficult to orient designers into a cooperative attitude, rather than an advisory one in such a short time.

An excellent example of the effectiveness of the formal VE study procedures was for the Hartfield International Airport in Atlanta, GA. The project consisted of the construction of a passenger terminal facility of approximately 704,000 square feet, a people mover mall of 403,000 square feet, a mechanical building of 9,000 square feet, and a concourse area totalling approximately 1,414,000 square feet. The design

proposed a four concourse concept connected by an automated guideway transit system. The heating ventilation and air conditioning equipment were designed for the rooftop installation on the concourses. A formal study was conducted under the direction of the architect/engineer firm of Smith, Hinchman & Grylls from July 27-31, 1976. There were twenty-five attendees including representatives of the airlines, the City of Atlanta, and the architect/engineer staff (14).

The study was conducted very early in the design process, therefore, only rough schematics and some verbalized design input was available for input to the group. Two cost models were developed, one for the terminal and one for the concourses. From these models the areas of greatest savings were determined to be: 1) layout, 2) exterior closure, 3) superstructure, and 4) mechanical. Four study teams were created, one for each area of greatest savings potential. Each team executed a full 40-hour project review using the formal VE job plan. The results of the workshops was that 126 proposals for cost savings were generated. Of these, 53 ideas were implemented with an estimated initial savings of \$7,000,000. These initial savings were more than doubled when follow-on costs of ownership were calculated (14).

The principle items of change were: a reduction of terminal in both volume and area by relocation of the mezzanine, a reduction of structural spans, a modification of exterior skin plus interior finishes, and a reduction in glass area to reduce energy usage. The airport as constructed has approximately 38% less energy usage than a comparable airport in Dallas, and 33% less than one in Chicago. The project was bid under budget with a return on the VE investment of fifty to one (14).

The 40-hour VE workshop produced good results in the case of the Atlanta Airport and many other studies, but it has also been judged as an arbitrary time frame for results, and more important for training than for actual studies. Frequently projects are not intended to undergo formal VE studies, but the owners turn to VE techniques

because their projects are over budget.

In most cases the owner hires an architect/engineer firm to design a facility with certain requirements. The owner has a budget for the project, but when the preliminary design estimate or the bids received exceed the budget, the owner seeks to reduce costs. He can choose to use conventional cost cutting techniques such as reducing quality, quantity, or performance in some way, or he can utilize VE techniques. Other techniques may reduce inherent quality by cheapening the finished product to reduce cost. The objective of VE in these cases is to identify and eliminate unnecessary cost without loss in needed quality or reliability.

The most common method of VE application in these cases is by constructing some type of cost model, identifying high cost areas with potential for savings, and conducting in-depth studies of these areas. One example of this method was for a switching station for radio, telephone, telegraph, television, and other communications media. The project involved the rehabilitation and conversion of existing office space. The budget for the work was \$500,000, but the preliminary estimate was for \$590,000. The VE team used Pareto's Law to identify 7 items, out of a 28 item breakdown analysis for the project, that accounted for 82 percent of the cost of the job. The designer's intent to meet criteria for new facilities such as 10 foot floor-to-ceiling height, and standard design procedures such as illumination levels and floor construction accounted for the high cost items. The study team made three recommendations: 1) keep existing suspended ceiling except for modifications required for new HVAC system; 2) utilize existing light fixtures with augmentation of task lighting; 3) delete requirement for floor screed works. The result of the study was a savings of \$103,000, and the project was built within the funding limit (4).

Frequently compressed design schedules preclude the application of VE during that phase of a project, therefore value engineering change proposals in contracts provide

a low-cost opportunity to use the talents of contractors to reduce costs. Most designers would agree that original designs could be improved upon, and alternatives could be adopted that are more cost effective, but this would require more time, and more importantly to the owner, more fee (4). Contractors have the advantage of being in close contact with day-to-day construction operations, so they can offer creative ideas to help solve problems. Some examples of accepted VECP's are (18):

1. Contractor proposed to change conventional cast-in-place retaining wall to reinforced earth wall . Savings of about \$1,717,000.
2. Contractor reduced borrow haul by negotiating his own borrow site. Savings of \$179,000.
3. Contractor proposed the use of plastic junction boxes instead of cast-iron boxes. Savings of about \$140,000.
4. Contractor proposed the change of original design of sheet piling with limited availability to sheet piling readily available. Savings of about \$120,000.
5. Contractor proposed painting with primer to 1.5 feet below low-water datum instead of painting full length of H-piles. Net one year savings of \$7,000.

VECP's are gaining increased acceptance in both private and public firms. The contractors do not use formal VE techniques in most cases, instead they rely on their experience and creativity concerning construction operations. They share the resulting savings with the owners based on the sharing formula in the contract incentive clause.

6.2 HVAC Applications

The rising costs and decreasing availability of energy resources has made energy optimization one of the goals of value engineering studies. It is no longer possible to design buildings without specific reference to energy consumption predictions. A building with lower initial and projected energy consumption will have more value for the owner (52).

Many different factors affect the energy consumption of buildings, but the most important factor is the desired climate control within the building. Building designs provide heating, ventilation, and air conditioning (HVAC) systems to control the environment inside the buildings. These systems are mechanical in nature, and they consume energy by using fuels for a source of heat energy and using electrical power to operate fans, pumps, and other equipment. Other design criteria such as building orientation to the sun, building configuration, the outside envelope, outside glass surfaces, lighting systems, and installed equipment greatly affect the amount of energy required for the HVAC systems to maintain the desired environment (52).

The amount of energy to heat and cool buildings has often been based on the expected extreme temperature conditions for the location. This has resulted in waste because the systems operated inefficiently during the balance of the year in order to have the capacity to operate during infrequent extreme conditions (52). Building HVAC systems are now being designed with much more flexibility in the controls of the systems. Variable speed fans, variable volume pumps for cooling water, and variable-air-volume systems are being used more frequently to operate systems at optimum efficiency levels. The systems are operated independently depending on the occupancy and activity levels of specific areas of the building. The use of more flexible systems has also created a need for more sophisticated controls for the systems. These

controls are used to shut off fans, turn down thermostats on temperature controls, to shut off humidification cycles, to automatically close air dampers and to totally shut down building systems in areas of the building which are not being used at the time.

Value engineering in the HVAC field is constantly changing, as better methods become economically feasible. Value engineered improvements are first proposed and then developed and refined until they become the accepted state-of-the-art. Ten years ago the typical HVAC system for an office building was a by-pass multi-zone system. Changing technology, aided by value engineering efforts, has made variable-air-volume systems with perimeter heat the system now chosen for 95% of these buildings. Similar advancements were made with high-efficiency fans. These fans were value engineered in the past, and now are accepted as the standard in most buildings.

A new technology, which is currently being developed in the HVAC field, is the concept of thermal storage, and thermal storage illustrates the type of value engineering efforts in this field. Thermal storage is not yet widely accepted, but VE studies have shown it to be a viable alternative in some instances. In Georgia, studies of thermal storage have been initiated in response to the changes in electric rate structures, which are expected with the start-up of nuclear plant Vogtle. An electric demand charge will be based on the highest demand that your building has during the year. For Atlanta this might be expected to occur on a hot afternoon in August, so building owners will pay a demand charge the rest of the year, based on that highest demand in August. In addition, time-of-day rate structures charge higher rates during the high use part of the days. Thermal storage is an alternative way to reduce these peak demands during the day.

A typical study might start with determining the peak load of your building to be 500 kw, which would equate to roughly a 500 ton system. A thermal storage system

consisting of either melting ice or chilled water storage may be able to save you 200 tons (200 kw). The cost of electric power is approximately \$108 per year per kw, so the operating costs savings are over \$20,000 per year.

The VE study of alternatives then comes into play with the selection of the chiller size. The first choice would be to buy a 500 ton chiller and run it according to the demand. Another choice would be to buy a 300 ton chiller with a storage system capable of 200 tons. The 300 ton chiller would be run at off-peak times, such as nights, to make the ice or produce chilled water for storage. The cooling capacity stored in the form of ice or chilled water would be used to augment the 300 ton chiller during peak cooling periods of the day. This would limit the peak load to 300 tons.

The factors to study include the difference in first cost of the 500 ton chiller versus the 300 ton chiller with 200 ton storage system. The next factor is the savings in operating costs for the 300 ton chiller, and how long it will take to achieve payback on the higher initial costs. Another factor which affects aesthetics rather than costs is the possibility that the building will be used at night. This possibility would mean that the chiller would have to be used to cool the building rather than convert its tonnage to storage that night. This could mean that not enough storage of ice or chilled water is accomplished, so the undersized chiller will not be able to cool the building the next day. This is a tradeoff or risk that the engineer or owner must take into consideration.

In order to reduce the initial costs of the storage system, the engineer would use VE techniques to locate the highest cost areas to study. In a typical HVAC system the sheetmetal and ductwork account for 35% of the total costs. Once the decision is made to go with the smaller chiller, a VE study might compare the benefits gained from using an ice storage system which uses the ice to produce 32 degree water rather 42 degree water. This water could then be used to produce 38 degree air rather 50 degree air. The cooler air would allow the designer to reduce the duct sizes, and use powered

mixing boxes to mix the cooler air with return air from the ceiling plenum. The smaller ducts would require smaller air handlers of say 10,000 cfm rather 14,000 cfm. The value engineer would evaluate whether the savings in ductwork and smaller air handlers would balance out the initial costs of the storage system.

Besides thermal storage systems, smaller chillers could be used by changing the sizes of air handling units. A full capacity chiller for the building may produce 43 degree water, which an air handler with six rows of coils converts into 55 degree air for the occupied space. A smaller chiller may only be able to produce 45 degree air, which would require an air handler with eight rows of coils. The value engineer must evaluate whether paying less for the chiller and more for the air handlers is more cost effective than the other way around. One factor which would affect this choice is the size of the building, and therefore the size of the chillers and the number of air handling units required.

The temperature of the chilled water might also affect the size of the piping required. The difference in the water temperature would affect the rise in temperature of cooling coils to perhaps 18 degrees instead of 16 degrees. The higher rise might let the designer drop from eight inch to six inch pipe. The reduced size of pipe could be a significant savings, depending on the height of the building.

The configuration of the chillers has a great impact on the efficiency of the system. A parallel flow chiller is not as efficient in transferring heat as a series counter-flow chiller. You would get a better kilowatt per ton efficiency but the pressure losses in pipe are additive, producing additional operating costs for the pumps.

The various technologies for the components of the HVAC system are also dependent on the desires of the owner. The vast majority of all projects are budget driven, but different trade-offs can be considered. The builder of a speculative office building may require no longer than a three-year payback on his building, so that he can get his

money out of it, and then sell the building. This type owner is not interested in taking risks with new technology with indefinite paybacks; he just wants a comparable system with what his competition has. A corporate owner who is building for himself will probably look at a longer payback period, and systems which will save energy costs over the long run. He may also be more willing to try a new technology that does not yet have a long track record of success, such as thermal storage. The unique personalities of the owners make every situation different, so the value engineer must find out the owner's motivation early in the study. The preferences and motivation of the owners is as important a decision criteria as the engineering considerations.

This discussion has shown some of the many pieces of the puzzle which must be considered to choose the optimum HVAC system. It would be impractical to try and list all the factors and possible trade-offs because each project is unique. Factors such as initial costs, operating costs, local power company rate structures, and owner motivation are all important to consider during the value engineering study. As much information should be gathered during the information phase as possible, so that accurate weighting of criteria and selection of the best alternative can be made.

6.3 Government/DoD VE Programs

The Federal government formally introduced VE over thirty years ago, after Lawrence Miles' successful work on value analysis and engineering at General Electric Company. The Department of Defense (DoD) recognized the contributions that VE could have toward limiting overall expenditures while maintaining essential functions. With few exceptions, it has been mandated that VE provisions be included in most DoD contracts since June 1962. The purpose of the provisions is to encourage contractor participation in the program and to realize full benefits of cost reduction opportunities and innovations (18).

Shortly after the VE program was established, the DoD made a study to determine the range and degree of application of VE. This study identified seven factors which were responsible for about 95% of the savings realized by VE changes. The seven factors were (18):

1. Advances in technology
2. Questioning specifications
3. Excessive cost
4. Additional design effort
5. Change in user's needs
6. Feedback from tests/field experience
7. Design deficiencies

Usually it was a combination of several of these factors that was the basis for the savings on a particular project.

The DoD VE program emphasizes two distinct elements. The first element is an in-house effort either with by DoD civilian or military personnel, or by VE consultants hired specifically to conduct studies and make proposals during design development. These are called Value Engineering Team Studies (VETS). The second element of the program is the Value Engineering Change Proposals (VECP), which are used to stimulate the contractors to perform VE and develop and submit costs saving changes during the construction phase of projects (18).

All projects which have been determined to have a potential for return on investment of 10 to 1 or larger are to be considered for VETS. Particular attention is paid to projects with a design and construction of over \$2 million. VETS are initiated immediately after the completion of 35% design. An interdisciplinary team is

assembled for a study of not more than 40 hours. The classic VE job plan is followed, and all steps are properly documented. The architect/engineer for the project will review the changes proposed by the team and reach an agreement of acceptability or rejection for each. The final word on whether or not the changes are implemented is made by the government contracting officer (18).

The Defense Acquisition Regulations (DAR) require that a Value Engineering Incentive Clause (VEIC) be included in all construction contracts of \$100,000 or more. The clauses do not obligate the contractor to take any VE action, but are designed to encourage action by sharing the savings achieved through VECP's. The current clauses give the contractor 55% of the savings realized by VECP's. Prime contractors are encouraged to extend the opportunities for VECP's to their subcontractors. The proposals are submitted to the cognizant contracting officer, with documentation from the contractor. They may be accepted or rejected, but if accepted, the savings must be shared with the contractor.

The Secretary of Defense has set a goal of saving 6% of the annual military construction budget for fiscal year 1986 through the use of VE. Significant savings have been realized in the past. For the past three fiscal years the Naval Facilities Engineering Command has conducted 482 formal VETS, with an average savings of \$500,00 and an average return on investment of 27 to 1. In that same time period 310 VECP's were reviewed with 66% accepted. The return on investment, calculated as the savings versus the cost to implement the changes, was approximately 40 to 1 (33).

The DoD program has shown that considerable return can be achieved on the investment made into a VE program. The summary of VE performance for all military construction in the last two fiscal years is summarized in figure 6.1 (33).

Value Engineering Savings and Military Construction

	<u>MILCON Budget(mil)</u>	<u>VE Savings(mil)</u>	<u>% of Budget</u>
Fiscal Year 1984:			
USAF	1501.0	16.4	1.1
ARMY	1184.1	46.8	3.9
NAVY	1206.5	71.9	6.0
GSA	337.0	N/A	N/A
Fiscal Year 1985:			
USAF	1572.7	32.8	2.1
ARMY	1593.1	104.3	6.5
NAVY	1534.6	93.5	6.1
GSA	479.0	4.0	0.8

Figure 6.1 - VE in Military Construction

6.4 Case Studies

There are many different instances where VE has been applied successfully to construction projects. In an effort to demonstrate the flexibility which allows VE to be applied in a variety of situations and projects, a series of case studies will be presented. The case studies will be presented in a summary format, so that the essence of the different studies is presented.

6.4.1 Willow Creek Dam

Willow Creek Dam was a proposed project to control flooding problems in Heppner, Oregon. A serious flood drowned 242 people in 1903, and while there had not been as serious a flood since that time, sporadic flooding created the proposed solution of a dam. The recommended design called for a rock fill dam with a central impervious core protected by sand and sandy gravel filters, and having an estimated completion time of

three years (24).

A one man study was conducted by William Kelly of Value Engineering Services Transworld (VEST) during the late summer of 1978. A total of twenty-four alternatives were generated, the most economical of which was a dam consisting of rock fill and a roller compacted concrete deck. This alternative was estimated to save \$5 million over the original design. These proposals convinced the government representatives to contract with VEST to form a study team with an initial budget of \$40,000. The VE study took three months, and utilized the expertise of over twenty consultants to arrive at four recommended alternatives. The most cost effective alternative was a rock fill dam with roller compacted concrete upstream face. The recommended solutions met with opposition from several sectors within the community, especially defenders of the original design (24).

The VE study team was forced to perform functions not normally expected, including appearing at a town meeting and intensive questioning from factions opposing the change in design. After several months of infighting, the roller compacted concrete solution was accepted. The dam was finally constructed in a period of nine months and at a savings over the original design estimate of \$11,600,000. The new technology introduced by this dam has led to six more roller compacted concrete dam being constructed, with many more under design in the U.S. and the rest of the world (24).

6.4.2 Training Building

This case is an example of a formal 40-hour Value Engineering Team Study conducted by the Department of the Navy. The project consisted of a three-story structure with 32,952 square feet of area, supported by a pile foundation, with a grade-beam supported first-floor slab. The building was to be attached to a similar

building currently under construction and was to be similar in construction. The 35% design estimate for the structure was \$2,921,000 (35).

U.S. Cost Incorporated was contracted by the Navy to perform the study in accordance with DoD policy. The team consisted of a team leader, architect, and one structural, mechanical, and electrical engineer. The architect/engineer for the project, Sherertz, Franklin, Crawford, and Shaffner, provided the study team with complete sets of 35% drawings. In addition the designer briefed the team on the basis of the design, cost estimate, project requirements, and site information.

A cost model (figure 7.1) was constructed for the facility with the main work areas being mechanical, electrical, architectural, structural, and supporting buildings. The two most significant cost areas were architectural with 32.3% of the total building cost, and structural with 27.7% (35).

The creative phase of the study was conducted using brainstorming techniques. A total of 40 cost improvement recommendations were generated. The balance of the study was spent evaluating these recommendations for savings without degradation of function or performance. Specific written proposals were developed for the proposals that were judged to be beneficial to implement. Each formal proposal contained sections on the original design, the proposed change, estimate of cost savings, listings of advantages and disadvantages, justification for implementation, and sketches. Example of the proposals are shown in Appendix A.

One example of a savings proposal was for the exterior of the building. The design called for a brick veneer exterior with an 8 inch concrete block back-up. The proposal suggested substituting an exterior DRYVIT system on 6 inch metal studs and 1/2 inch drywall as an exterior finish material. The main advantage was a cost savings of an estimated \$144,341. The disadvantages were that the system would not be as durable as designed, and it would be a contrasting material with the building it was to

be joined with. The study felt that the DRYVIT system could be effectively designed, so that aesthetics were preserved (35).

The roof of the building as originally designed called for the use of an EDPM single-ply membrane with rigid insulation. The VE study team recommended the use of a 4-ply built-up roof system. There were no perceived disadvantages and aesthetics were not a factor in the analysis. The estimated cost savings for this proposal were \$27,716 (35).

One of the significant structural recommendations called for the replacement of wide flange structural steel beams and girders with joist and joist girders. Wide flange beams would still be used to resist moment in the beam direction, but joist girders would be used to resist moment in the girder direction. The proposed solution would reduce construction time, reduce the structural slab system due to closer joist spacing, and save an estimated \$83,900 (35).

The original design provided a heat source for the building by connecting into the existing central steam system on the base. The VE team proposed the installation of an oil-fired water packaged boiler in the building with a 4,000 gallon underground steel fuel oil storage tank. The estimated savings were to be \$65,816, and the main disadvantage was that the existing steam would provide 50% additional steam capacity (35).

A total of 34 of the original 40 proposals were accepted as feasible by the study team. As the cost model indicated, the best areas for cost reduction were the architectural and structural areas, which contained 24 of the 34 proposals. The proposals totalled \$948,457, or 32.5% of the 35% estimate design estimate (35).

6.4.3 Office Building Energy Evaluation

In an effort to combine innovative technologies of architectural, mechanical, and

electrical system components, a team of consultants joined together to produce a cost effective and energy efficient building. The project was a 18 floor office building in Atlanta, GA. The initial design included an efficient envelope and variable-air-volume individual floor air conditioning systems. The building had a low projected energy utilization rate and lower first cost than the regional average for similar buildings. The team of engineers and architects sought to improve on this starting point, until the building reached maximum efficiency (1).

A checklist of alternatives for increasing energy efficiency was reviewed and evaluated. Twenty-four items were evaluated for the building, including: building orientation, glass and glazing, entry doors, counterflow chillers, thermal storage, direct digital control, lighting optimization, and high efficiency transformers. Seventeen of the items were considered to be life-cycle cost effective and were included in the project (1).

The overall HVAC load was reduced by using 1.2 watt per square foot lighting, high performance insulating reflective glass, orienting the building axis 60 degrees from north, and reducing the glass height on the southeast and southwest exposures by 35 percent. The lighting was optimized by using deep baffle parabolic louver heat removal fixtures and photocell-controlled atrium entry and parking lot lights. The cooling generation system improvements included using series counterflow water chillers and a cooling tower economizer. The peak electrical load was reduced by increasing the size of the emergency generator, and using it during peak load periods. The generator alone produced annual savings of \$50,000 (1).

6.4.4 Wastewater Treatment Plant

In 1979 a 6.2 million gallon per day (MGD) wastewater treatment plant was designed for the city of Claremont, NH. Because of EPA guidelines which called for VE study of all

plants with estimated construction costs of over \$10 million, the Claremont was required to be studied for value. The study was unusual because the design was substantially complete rather than at the 35% stage, and because the basis for design was also to be studied (44).

The basis for design is usually not subject of questioning by a VE study team, but the first phase of the Claremont study was designated for analysis of this aspect. The 6.2 MGD size of the plant was the result of a report prepared by a planning group. The basis for the projected size was future residential, commercial, and industrial growth. The industrial growth was dominated by three companies, so the VE team started their study by meetings with the leaders of the companies. The team sought commitments from the companies for their contributions to the plant. One company withdrew completely stating they would continue to use their own treatment facility, while the others reduced their projected waste contributions (44).

The commercial and residential projections were investigated by reviewing the zoning maps for total area available for development in the Claremont area. Tax records were also reviewed to establish the historical rate of growth for the area. Per capita water consumption was calculated with the use of previous years consumption figures (44).

The result of the first phase of the VE study was that the original projections were determined to be overly optimistic. The total acreage and historical growth rates did not support the planning report's projections. Based on their research, the VE team recommended that the size of the plant be reduced from 6.2 to 3.9 MGD, a reduction of approximately 32% (44).

The second phase of the VE study was to conduct two 40-hour workshops to study the design and make cost saving recommendations. The first workshop addressed the liquid treatment processes, while the second looked at solids handling facilities and general

service and administration building considerations. The reduction in size of the facility made for the elimination or reduction in several functions of the plant. In addition, the team made recommendations to reduce the complexity of the treatments processes. The implementation of the recommendations resulted in a capital cost savings of \$9,570,000, or approximately 50% of the original design, and an operation and maintenance savings of 32% per year.

CHAPTER 7

INTEGRATION AND CONCLUSION

7.1 Management Participation

During the presentation of value engineering study results to a design firm, the question was asked, "How can we manage our firm such that we will not need a value engineering study?" This question could apply to owners and contractors, as well as designers. The answer is that although additional efforts can reduce unnecessary costs, there are always unnecessary cost in every job. These costs mean poor value, and there are a number of reasons why these costs creep into every job. Some of the more common reasons are:

1. Lack of time
2. Lack of information
3. Lack of the idea
4. Misconceptions
5. Temporary circumstances that inadvertently become permanent
6. Habits
7. Attitudes
8. Politics
9. Lack of fee

All parties in the construction context can have an impact on these costs. The owner may set primary criteria for the facilities or operate the facilities in a manner which promotes poor value. The designer is working under a number of constraints, such as time and money, which limit his ability to eliminate all unnecessary costs.

Contractors have a large impact upon the value of a project through the quality of workmanship, and the skill and creativity they use to produce a better value product.

Value engineering has been an established technique for over 30 years, and significant savings have been achieved by the technique when properly applied. Despite this fact, only about half of the participants in the construction industry are aware of VE, and perhaps only 1 percent actively utilize the techniques (13). A successful VE program requires top management involvement. The best value facilities or construction projects occur as the result of the combined management efforts of the owner, designer, and contractor.

There is a close relationship between VE and good management principles. Managers must cope with the uncertainty and complexity of new technologies, different personalities, and problem situations. A good manager must be creative, imaginative, and resourceful to be successful. The objective of completing construction projects on time, within budget, conforming to all regulations, and meeting required specifications can only be achieved through innovative management.

There are many reasons why VE is not used more often such as: the fear of the unknown, doubt as to whether it will work, rigid compliance with criteria, and the time-consuming effort required. These are reasons why management may choose not to fully support a VE program, but if VE is viewed as simply a systematic way of approaching a problem then these reasons are not valid (29).

Some of the principles for successful application of VE apply directly to good management techniques(29):

1. Teamwork
2. Overcome roadblocks
3. Use good human relations

4. Be a good listener
5. Use key questions
6. Use checklists
7. Keep good records
8. Use good judgement

VE can be applied during a formal study situation, as a method for eliminating excessive costs, for finding solutions to problems, or in everyday management situations. The key is for the managers to understand that it is a tool to be used for successful management in today's environment of change and uncertainty.

7.2 Value Management Organization

Many of the techniques of VE are currently practiced in the construction industry, such as analyses of HVAC systems by mechanical engineers, or economic analyses of different construction methods by construction managers. In most situations each division or unit of the company is responsible for setting the criteria, and implementing and reviewing the VE program within its own area of expertise or control. This method of operation tends to optimize subsystem performance, while ignoring the good or bad affects this has on the overall project. There are many instances where improving or optimizing performance in one area of work may adversely affect other areas of the project, and be detrimental to the performance of the project as a whole.

It is recognized that no two companies function exactly the same within the construction industry. There are contractors, subcontractors, design-build firms, construction management firms, construction consultants, and a myriad of combinations of the above. The implementation of a VE program varies for each firm

and maybe for each different project. It is impossible to present an implementation procedure which will apply in every case, so general guidelines for a successful VE program are presented.

A successful VE program should take a team approach and coordinate the efforts of all the various divisions and units of the company. The team approach applied during design review and construction of facilities should not be hampered by the organizational boundaries between the different areas of the company, but will be able to challenge high-cost items or practices wherever they occur. Top management support is required to implement such a program, by providing the necessary resources in personnel and funding. It is recommended that firms with over \$10 million in construction related expenditures establish a full-time program, but it would be wise for smaller firms to limit their VE investment to a part-time basis. Hiring VE consultants for concentrated studies as required would probably be the best policy for these companies (13).

VE should be assigned as a staff function to the upper management levels of the company. This will enable the the VE staff to receive management guidance, cross organizational lines, and have the freedom to operate wherever their skills are most required. The VE staff should function close enough to the principle areas of work, so that they are knowledgeable of the requirements and status of construction programs, and are involved in the design review and change proposal review processes (13).

The size of the VE staff will depend on the size and activity of the company, but a VE program supervisor is required. He is the focal point and has the authority for the program. He is responsible for coordinating the analysis of the technical aspects of the design and construction of selected projects. It is his responsibility for seeing that the VE process is used to help the company complete the projects at the lowest possible cost, while meeting all the functional criteria of the project. He should also continually

promote cost-consciousness in all areas of company operations through effective publicizing of the program and conducting training. Some of the typical duties and responsibilities of the supervisor should include (13):

1. Selecting and assigning priorities for the application of VE efforts based on the magnitude of potential savings.
2. Coordinates VE studies with the heads of other divisions within the company.
3. Plans, leads, and participates in the conferences on VE recommended construction changes.
4. Develops procedures for a feedback system to report VE information from the field activities to various management levels.
5. Visits field organizations to observe current methods and practices, and ensure that they are conducive to efficient and economical prosecution of the program.
6. Applies VE to the activities of the main office.
7. Coordinates company VE training program.

The VE staff should receive broad objectives and general policy guidelines from the upper management levels of the company. The staff will have the authority to work within these guidelines to implement the program throughout the company. In order for management to justify the expenditures for a VE program, the results must be reported in an unbiased manner. A periodic report of VE actions and accomplishments should be made to the manager to whom the VE supervisor reports. The report should have sufficient information, so that an impartial audit of the results can be performed by the accounting department as desired.

Goals should be established for potential savings resulting from the VE program. DoD VE goals are set at 6% of the MILCON budget, and a 10 to 1 savings return on VE investment. Similar goals are obtainable by private corporations. For a large corporation an overall operating budget savings of 1% to 3% is reasonable. For large projects that are estimated over budget, a goal of 20% reduction in estimated costs is possible. The isolation of areas of poor value within a project should produce savings of 10% to 50%, with an average reduction of 30%. Depending on the size of the construction effort, the return on the VE program should range from 3 to 20 times the investment. Smaller jobs of less than \$15 million should have a return of 3 to 10 times the investment. Large construction efforts of over \$100 million should return savings of 10 to 20 times the investment (13).

7.3 Training

An ongoing emphasis on VE training within the company is a prerequisite for realizing the full potential of VE. Personnel must be trained in the use of VE techniques, and a favorable climate must be established for a successful VE program. VE is a subject which is taught on a limited basis at schools and universities, therefore it is up to the organization to implement a training program, so that their personnel can obtain the skills to operate a VE program. VE training programs also demonstrate management's interest in the development of additional skills by the employees, therefore it serves the interest of both management and employees (18).

A VE training program requires the participation of personnel from all areas of the organization. The VE supervisor acts as the focal point for all training, and if the company has a training staff, he would coordinate the program with the staff. The VE supervisor should have experience in working with VE, and thorough knowledge of its methodology. In addition, the person should have effective communication skills to

present ideas with tact and diplomacy to personnel throughout the organization (18).

There are several types of VE training, the most intensive of which are workshop seminars. These are the main source of formal VE training designed to teach VE theory and methodology. Workshop seminars tend to identify certain personnel with an aptitude for VE, and therefore serve as a first step in developing personnel who could become full-time value specialists for the company. The best way for people to learn a new technique and demonstrate its effectiveness is by letting them perform it (52).

A typical workshop should consist of 40 to 80 hours of effort conducted in full to half-day sessions over a period of two to four weeks. The sessions should consist of approximately a 50-50 mix of lectures and actual project work. The time between sessions is needed to obtain cost and engineering data for the projects being studied. The lectures are used to communicate the theory and background of VE methodology and creative problem solving techniques. Guest speakers can be provided to present expert knowledge in various areas of project management and communicate successful VE experiences with which they were involved (18).

Actual project work is an essential element of the workshop seminar. The workshop participants are divided into teams, and they apply the VE job plan to a portion of a current job. The items should be selected for study by the workshop based on the following characteristics (18):

1. Prejudged as good candidates for cost improvements.
2. Consist of 5 to 50 elements.
3. Complete drawings, specifications, and cost estimates are available.
4. Total program cost is large enough to achieve a significant saving.

The trainees are led through all phases of the VE methodology by the VE supervisor, and this allows them to realize actual savings for the project. Although the seminar is intended as a training exercise, productive cost-saving work can result for the company.

Other training sessions, less formal than seminars, should also be conducted by the VE supervisor. Personnel can receive on-the-job training under the tutelage of qualified value specialists. They are taught to apply basic VE skills to their own specific work tasks and areas of responsibility. Rotational job assignments can expose employees to other aspects of the company's operations, and broaden their perspective about all the different factors which affect the value of the company's finished product. VE indoctrination sessions of varying lengths presented by the value specialists within the company promote company-wide understanding of the program. The content of the sessions will vary according to the make-up of the audience, but it generally should include: objectives of the VE program, concepts of value, criteria for applying VE, and organization and operation of the VE program (18).

The training sessions should be augmented by informal training methods. Effective means of helping promote value work for the company include the distribution of handbooks and manuals explaining value awareness and the company's program. Bulletins and newsletters, distributed periodically, act as continuing reminders for value work. Successful VE case histories should be advertised and employee efforts properly recognized by brief awards ceremonies or posting them on bulletin boards or other prominent places. All of these actions serve to heighten awareness of the program and reinforce the efforts of more formal training methods (18).

7.4 Conclusion and Recommendations

The benefits of a properly managed VE program have been demonstrated time and again through successful cost-saving alternatives. The construction industry as a whole has been slow to adopt the principles, therefore most of the VE work is still being done in the Government and manufacturing sectors of the economy.

The limited number of Certified Value Specialists (CVS) is perhaps one reason for the slow spread of VE to the construction industry. The solution to the problem of the limited number of value experts can perhaps be alleviated somewhat by the use of expert system computer programs. An expert system could be developed which would lead the user through the steps in VE methodology. The various questions and considerations which should be made at each step could be presented by the program. The methodology for evaluating the various alternatives created could also be presented and performed by the user interfacing with the program.

A computer program has not been developed which can simulate the creative process of an expert, but various questions can be presented which will stimulate the creativity of the user. A large data base of successful VE proposals could be integrated into the program to stimulate thinking, by showing alternatives which have worked in similar situations.

A Construction Management Special Research Topic in the area of expert systems for value engineering is recommended. The program could be general in scope, so that VE principles can be applied to any problem by use of the program. Specific areas of facilities design or construction could also be the target of the program. In this program specific questions, suggestions, and previously successful alternatives pertaining to that area could be presented to the user of the program.

APPENDIX A
EXAMPLES OF VE PROPOSALS

VALUE ENGINEERING PROPOSAL

PROJECT: SUBMARINE TRAINING BUILDING DATE: 10-14 February 1986

DESCRIPTION: USE SHEATHING ON 3-3/8" METAL STUDS AT THE EXTERIOR ENCLOSURE IN LIEU OF 8" CMU BACK-UP TEAM NUMBER: 1

Comprehensive description of "as designed" vs. "as proposed". Include Sketches as necessary.

AS DESIGNED:

As designed, the drawings indicate use of a brick veneer exterior finish material with an 8" thick concrete block, painted as a back-up.

PROPOSED:

It is proposed to replace the brick/block enclosure system with a brick veneer attached to a sheathing/metal stud/drywall back-up system.

SUMMARY OF COST SAVINGS

LINE NUMBERS REFER TO WORKSHEET 9 :

Original... (Total Initial Line 4)	<u>83,280</u>		
Proposed.. (Total Initial Line 4)	<u>41,058</u>		
Initial Savings... A-3	<u>42,222</u>	<u>1.52</u>	<u>\$ 64,177</u>
Life Cycle Costs Annual Savings (Line 16)			
Present Worth of LCC Annual Savings (Line 17)			
Annual O&M Savings (Line 12)			
Percent Savings Instant (C/A)			
Percent Savings LCC, Annual (D, Line 13 of Original Design)			
Percent Savings on O&M (Line 12)			

ADVANTAGES AND DISADVANTAGES AND JUSTIFICATION FOR PROPOSED CHANGE

advantages and disadvantages and include an essay type justification for your proposal. This justification should be complete enough so that subsequent evaluation by the reviewer will not require him to perform any new calculations or make any assumptions. PROPOSAL IN THIS REPORT SHOULD STAND ON ITS OWN.

ADVANTAGES: (Use additional sheet if necessary)

There would be a project cost savings of \$64,177.

The same sound insulating qualities as the designed composite wall STC rating would be achieved.

DISADVANTAGES:

The durability of the interior wall surface would be reduced and maintenance of the drywall finish may be increased.

JUSTIFICATION: (Essay type reasoning)

The substitution of 8" CMU block with a drywall/metal stud system will certainly enhance the interior finished appearance while providing a significant savings.

SKETCH DETAIL

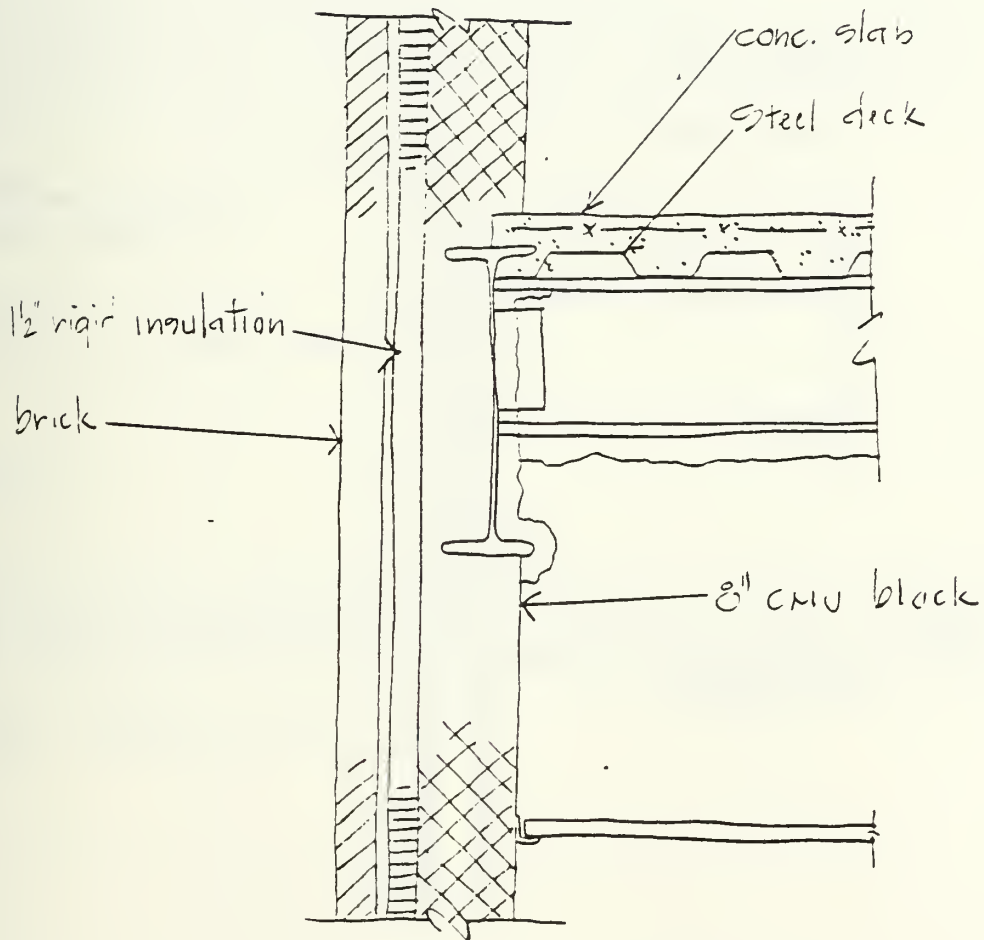

SKETCH DETAIL

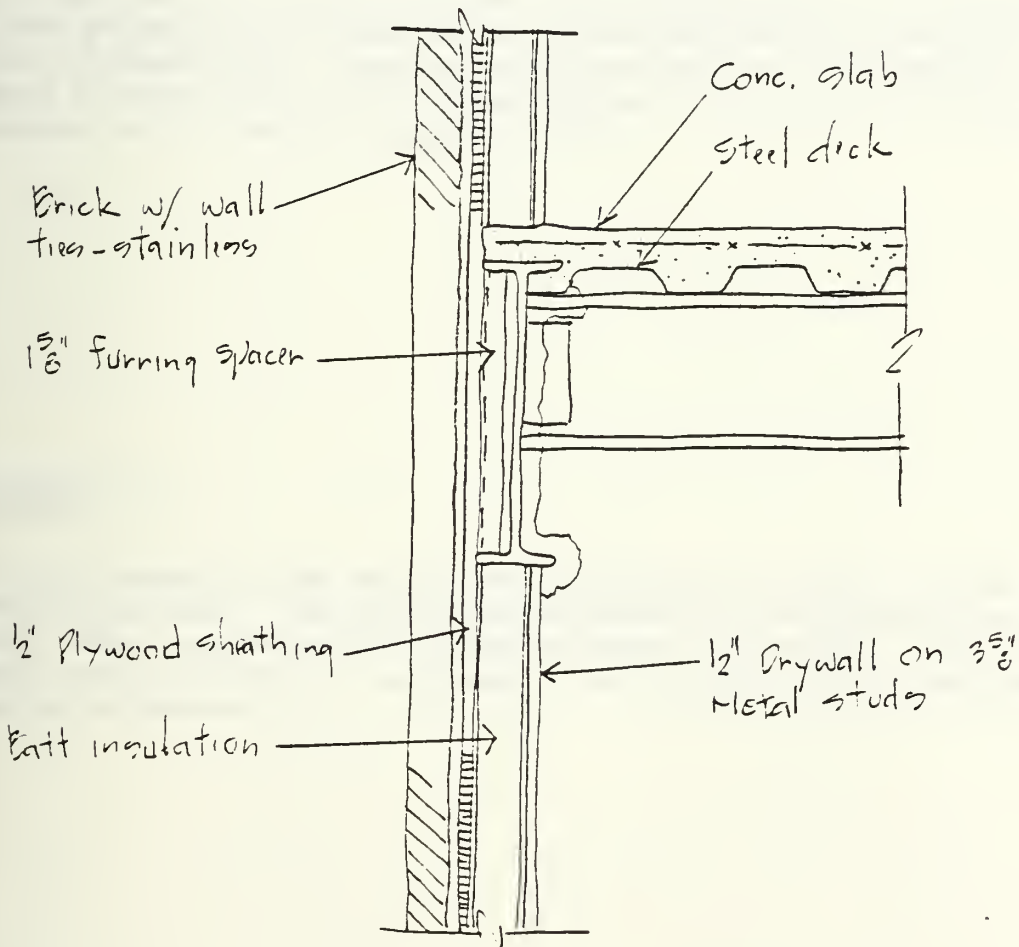

VALUE ENGINEERING PROPOSAL

PROJECT: SUBMARINE TRAINING BUILDING DATE: 10-14 February 1986
SURCHARGE THE SITE IN LIEU OF
USING A STRUCTURAL SLAB. TEAM NUMBER: 1

Comprehensive description of "as designed" vs. "as proposed". Include Sketches as necessary.

DESIGNED:

As designed, the slab on grade is a structural slab which spans from grade beam to grade beam. This is apparently a result of a late recommendation from the soils consultant on his experience with a similar sites in the area. The soils consultant first recommended an isolated soil supported slab.

PROPOSED:

It is proposed to use an isolated soil supported slab in lieu of the structural slab. This can be accomplished by surcharging the site with loose temporary fill for approximately two months. This surcharge will produce initial soil settlements and eliminate post-construction large settlements.

SUMMARY OF COST SAVINGS

NUMBERS REFER TO WORKSHEET 9 :

Original... (Total Initial Line 4)	<u>108,200</u>	<u> </u>	<u> </u>
Proposed... (Total Initial Line 4)	<u>50,900</u>	<u> </u>	<u> </u>
Initial Savings... A-B	<u>57,300</u>	<u>x 1.52</u>	<u>\$87,000</u>
Life Cycle Costs Annual Savings (Line 16)	<u> </u>	<u> </u>	<u> </u>
Present Worth of LCC Annual Savings (Line 17)	<u> </u>	<u> </u>	<u> </u>
Annual O&M Savings (Line 12)	<u> </u>	<u> </u>	<u> </u>
Percent Savings Instant (C/A)	<u> </u>	<u> </u>	<u> </u>
Percent Savings LCC, Annual (D/Line 13 of Original Design)	<u> </u>	<u> </u>	<u> </u>
Percent Savings on O&M (Line 12)	<u> </u>	<u> </u>	<u> </u>

ADVANTAGES AND DISADVANTAGES AND JUSTIFICATION FOR PROPOSED CHANGE

all advantages and disadvantages and include an essay type justification for your proposal. This justification should be complete enough so that subsequent evaluation by the designer will not require him to perform any new calculations or make any assumptions. YOUR PROPOSAL IN THIS REPORT SHOULD STAND ON ITS OWN.

ADVANTAGES: (Use additional sheet if necessary)

There would be a project cost savings of \$87,000.

Construction time would be reduced.

Construction is simplified.

DISADVANTAGES:

Minor differential settlements may occur.

JUSTIFICATION: (Essay type reasoning)

Initial recommendations to support the minor 100 psf loading were to use a soil supported slab. On the recent Naval Air Rework Facility project at the Norfolk Naval Station, the soils consultant agreed that surcharging the site would decrease differential settlements for lightly loaded slabs.

COST SUMMARY

TERIOR GRADE BEAMS

CONCRETE - 323 CY x (\$53.00 + \$3.50) = \$18250
 FORMWORK - 6968 SF x (\$0.73 + \$1.64) = \$16514
 Reinforcing - 37 Tons x (\$495 + \$425) = \$34040

GRADE SLAB

SLAB, Rein. Sealer (14183 SF) x (\$^(From CES.)2.19 + 0.59) = \$39428
\$108232

AS DESIGNED

URCHARGE SITE

loosely compacted fill (5' THICK) ← From CES
 (2700 CY) x (\$4.10 + \$0.35) = \$12000

Remove fill

(2700 CY) x (\$^{← FROM CES}1,85^{EQUIP} + \$0.35) = \$6000

GRADE SLAB

SLAB, Rein. Sealer
 (14183 SF) x (\$^(From CES)1.76 + 0.56) = \$32900
\$50900

AS PROPOSED

SKETCH DETAIL

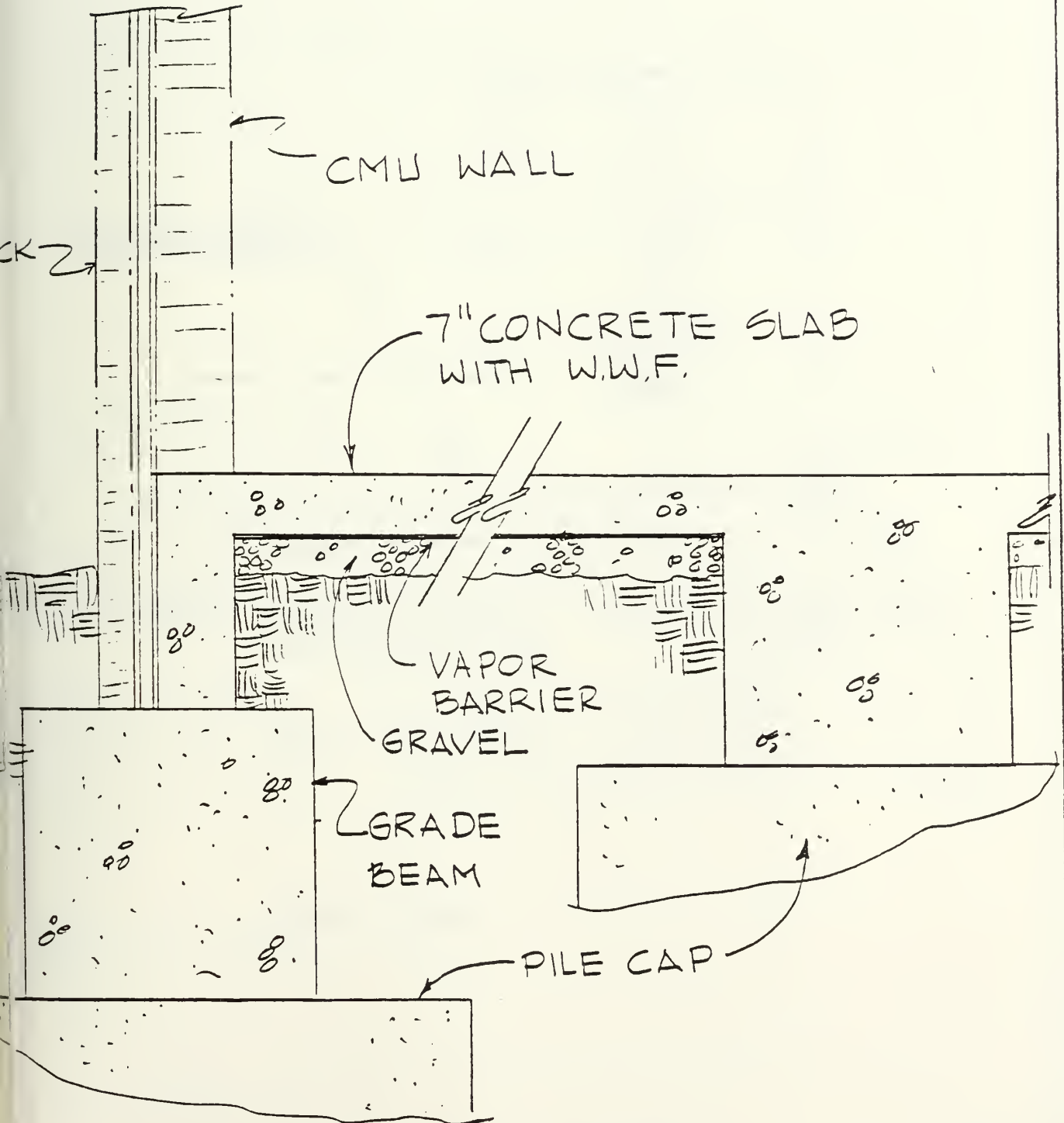

AS DESIGNED

SKETCH DETAIL

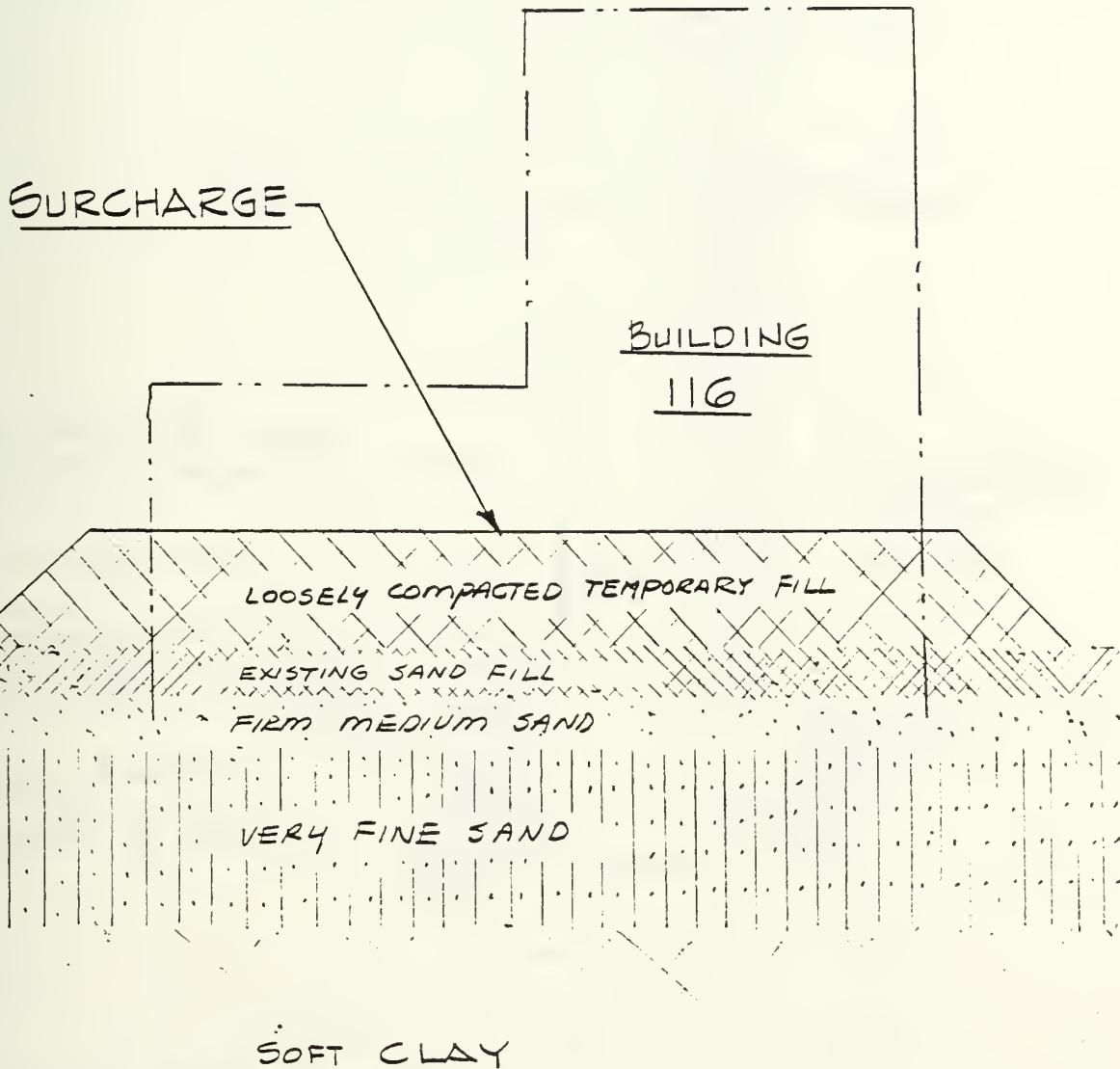

SKETCH DETAIL

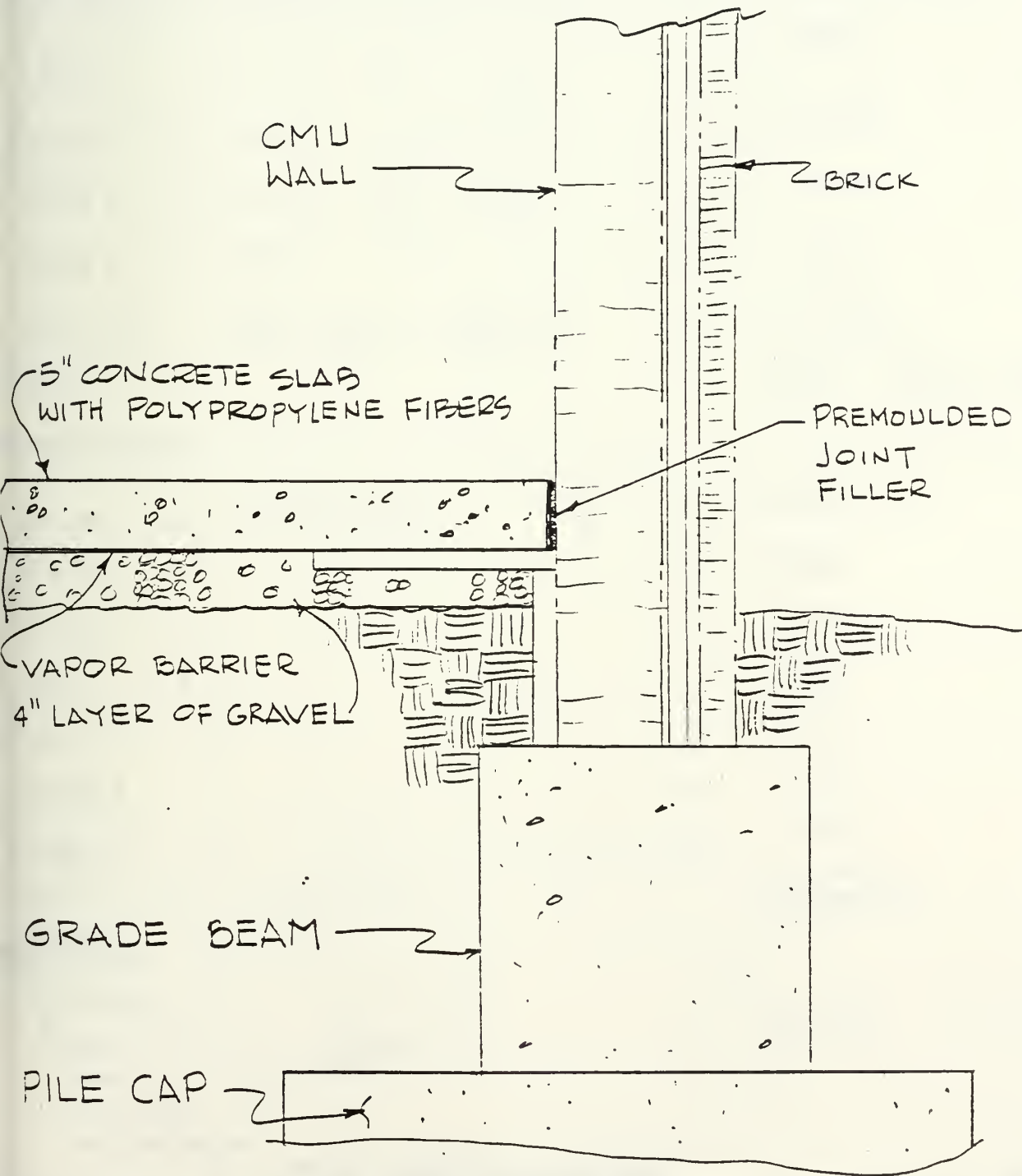

AS PROPOSED

CALCULATIONS

GRADE BEAM QUANTITIES

← SCALED OFF OF ARCH DWGS

$$\begin{aligned}
 (2.5 \times 2.5) (69.5' - 5') (5) &= 2015 \\
 (6.25^{SF}) (69.5' - 10') (1) &= 372 \\
 (6.25^{SF}) (79.5' - 5') (3) &= 1397 \\
 (6.25^{SF}) (79.5' - 10') (3) &= 1303 \\
 (6.25) (61.5 - 5') (4) &= 1412 \\
 (6.25) (35') (1) &= 219 \\
 (6.25) (202' - (2.5 \times 17)) (2) &= 1993 \\
 \hline
 8711 \div 27 &= 323^{CY}
 \end{aligned}$$

FORM WORK

$$\begin{aligned}
 (64.5) (5) (2.5) (1) (2) &= 1612 \\
 (59.5) (1) " " &= 298 \\
 (74.5) (3) " " &= 1118 \\
 (69.5) (3) " " &= 1043 \\
 (56.5) (4) " " &= 1130 \\
 (35) (1) " " &= 175 \\
 (159.5) (2) " " &= 1592 \\
 \hline
 &= 6968 SF
 \end{aligned}$$

EINFORCING

$$\begin{array}{r}
 \text{GR BEAM} \\
 323^{CY} \\
 \hline
 410^{CY} \\
 \text{TOTAL GR. BEAM}
 \end{array}
 \times
 \begin{array}{r}
 \text{TOTAL REINF} \\
 47 \text{ Ton}
 \end{array}
 = 37 \text{ Ton}$$

VALUE ENGINEERING PROPOSAL

T: SUBMARINE TRAINING BUILDING DATE: 10-14 February 1986
REDUCE HEIGHT OF PARAPET TO 1'-0" TEAM NUMBER: 1

Comprehensive description of "as designed" vs. "as proposed". Include Sketches as necessary.
SIGNED:

As designed, the roof parapet structure extends 3'-0" above the top of the roof deck. This occurs at both the one and one-half and third story roof lines.

PROPOSED:
 It is proposed to reduce the roof parapet height to 1'-0" wherever it occurs.

SUMMARY OF COST SAVINGS

NUMBERS REFER TO WORKSHEET 9 :

Initial... (Total Initial Line 4)	17,560	_____	_____
Proposed... (Total Initial Line 4)	5,387	_____	_____
Annual Savings... A-B	12,173 x 1.52	_____	\$18,503
Life Cycle Costs Annual Savings (Line 16)	_____	_____	_____
Present Worth of LCC Annual Savings (Line 17)	_____	_____	_____
Annual O&M Savings (Line 12)	_____	_____	_____
Percent Savings Instant (C/A)	_____	_____	_____
Percent Savings LCC, Annual (D/Line 13 of Original Design)	_____	_____	_____
Percent Savings on O&M (Line 12)	_____	_____	_____

ADVANTAGES AND DISADVANTAGES AND JUSTIFICATION FOR PROPOSED CHANGE

Include all advantages and disadvantages and include an essay type justification for your proposal. This justification should be complete enough so that subsequent evaluation by the designer will not require him to perform any new calculations or make any assumptions. YOUR PROPOSAL IN THIS REPORT SHOULD STAND ON ITS OWN.

ADVANTAGES: (Use additional sheet if necessary)

There would be a project cost savings of \$18,503.

Construction time would be slightly reduced.

DISADVANTAGES:

This building (P-116) would not blend quite as smoothly into P-108.

Rooftop equipment may be slightly more visible from certain angles.

JUSTIFICATION: (Essay type reasoning)

A 1'-0" high parapet serves the functions of directing rainwater toward the drains, and providing vertical surface to flash roofing against, just as effectively as a 3'-0" high parapet. According to the A/E, large rooftop equipment will be screened anyway.

COST SUMMARY

8" CMU BACK-UP :

$$805 \text{ LF PARAPET} \times 2'-8 \text{ EFFECTIVE HEIGHT} =$$

$$2147 \text{ SF} @ \$2.60/\text{SF} \text{ (from cost estimate)} =$$

BRICK VENEER :

\$5,582

$$805 \text{ LF} \times 3'-0 \text{ EFFECTIVE HEIGHT} =$$

$$2415 \text{ SF} \times 6.5 \text{ BRICK/SF} = 15,698 \text{ BRICK}$$

$$15,698 \times \frac{\$763}{1000 \text{ BRICK}} = \text{\$11,978} \text{ (from cost est.)}$$

$$\text{\$5,582} + \text{\$11,978} = \underline{\underline{\text{\$17,560}}}$$

AS DESIGNED

8" CMU BACK-UP :

$$(805 \text{ LF}) (8" \text{ EFF. HGT.}) (\$2.60 \text{ SF}) = \text{\$1,395}$$

BRICK VENEER :

$$(805 \text{ LF}) (1'-0 \text{ EFF. HGT.}) (6.5) \left(\frac{\$763}{1000} \right) = \text{\$3,992}$$

$$\underline{\underline{\text{\$5,387}}}$$

SKETCH DETAIL

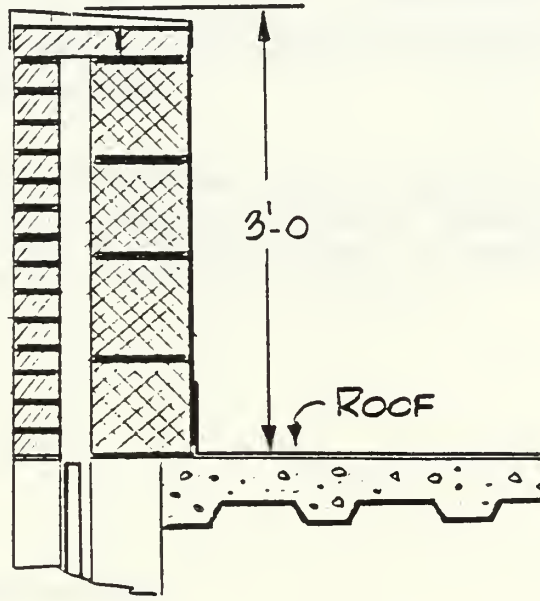

AS DESIGNED

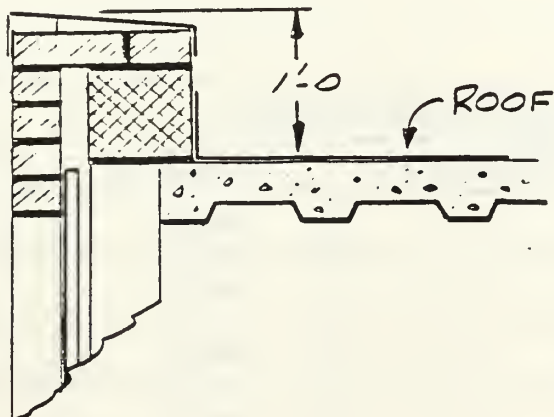



Hanscomb Associates, Inc.

**VALUE ENGINEERING
PROPOSAL**

PROP. NO.

A-21

PROJECT APPLIED INSTRUCTION BUILDINGSYSTEM ROOF - NEC BUILDINGLOCATION MCAS, CHERRY POINT, NCITEM ELIMINATE PITCHED ROOFCLIENT U.S. NAVY/ATLANTIC DIVISIONDATE 24 JANUARY 1986PAGE 1 OF 7FUNCTION AESTHETICS
ORIGINAL DESIGN: (Attach sketch where applicable)

The present design calls for pre-manufactured wood trusses with asphalt shingles to be erected on top of a concrete roof deck. These trusses were added for aesthetic purposes. The concrete roof deck is supported on 2 masonry bearing walls along each side of the main corridor.

PROPOSED DESIGN: (Attach sketch where applicable)

This proposal would eliminate the wood trusses and in lieu of these would add a built-up roof on insulating concrete fill on the regular weight concrete deck. The steel bar joists would be sloped $\frac{1}{4}$ " per foot for drainage. These bar joists would be supported on 1 bearing wall centered in the building and would slope $\frac{1}{4}$ "/1'0" toward the outside. One continuous bearing wall and footing would be eliminated and the area of the exterior wall would be reduced.

LIFE CYCLE COST SUMMARY	COST SAVINGS (PRESENT VALUE)		
	INITIAL COST	O & M COSTS	TOTAL LCC
ORIGINAL DESIGN	36,409	-	36,409
PROPOSED DESIGN	20,360	-	20,360
GROSS SAVINGS	16,049	-	16,049
IMPLEMENTATION COSTS	1,049	-	1,049
NET SAVINGS	15,000	-	15,000
PERCENT SAVINGS	41%	-	41%



Hanscomb Associates, Inc.

VALUE ENGINEERING
PROPOSAL

PROP. NO.

A-21

ADVANTAGES:

1. Initial Cost Savings of \$16,049.
2. Reduced construction time.
3. Eliminates wood construction.
4. Lowers building projected height to reduce exposure to sound transmission.

DISADVANTAGES:

1. Changes aesthetics.
2. Some redesign required.
3. Concerns over maintenance of flat roofs.

DISCUSSION/JUSTIFICATION:

With initial cost savings and minimal disadvantages, this proposal is recommended for implementation.

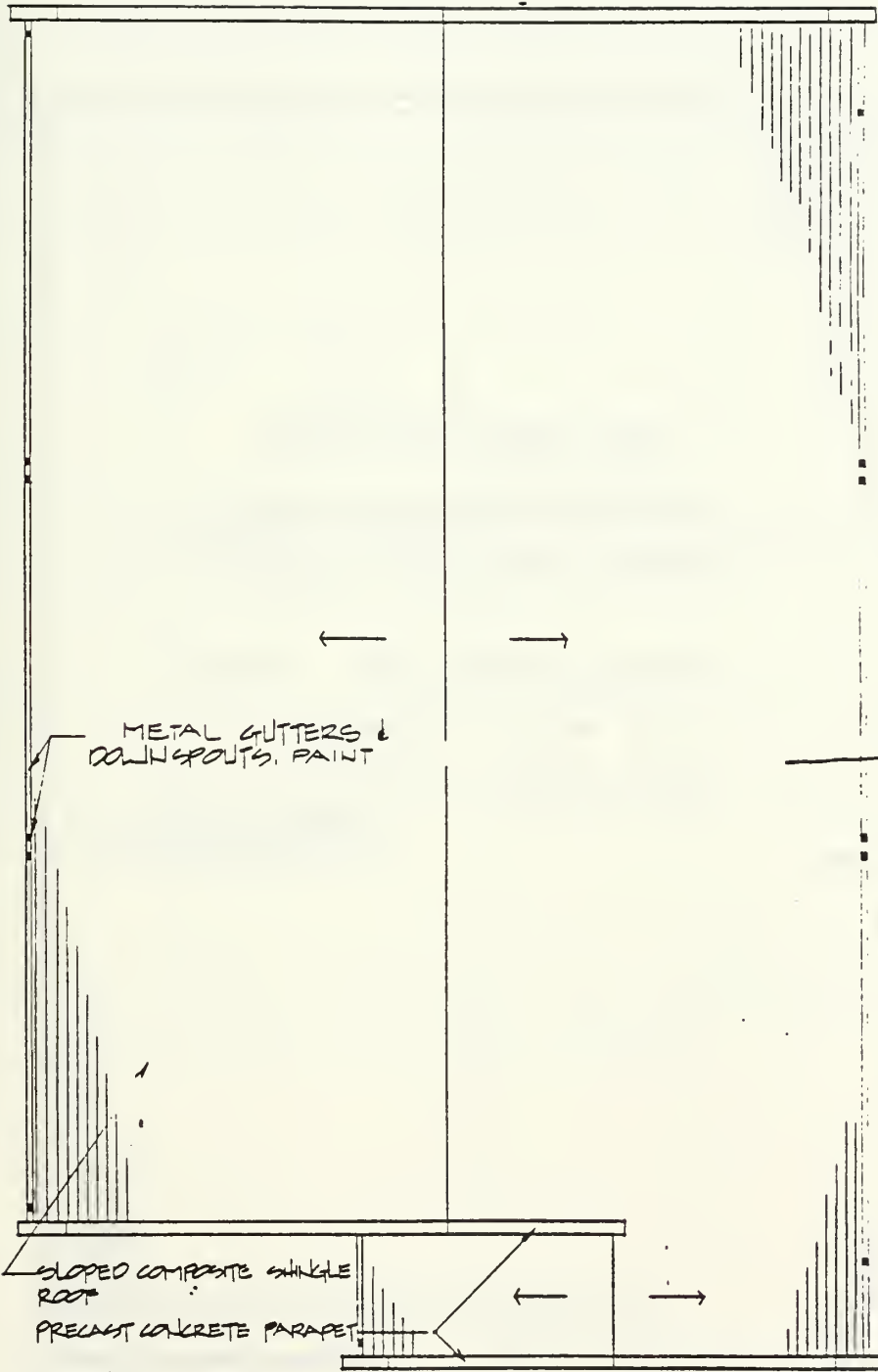
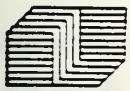

2 ROOF PLAN
1/8" = 1'-0"



Hanscomb Associates, Inc.

SKETCH OF PROPOSED DESIGN

PROP. NO.

A-21

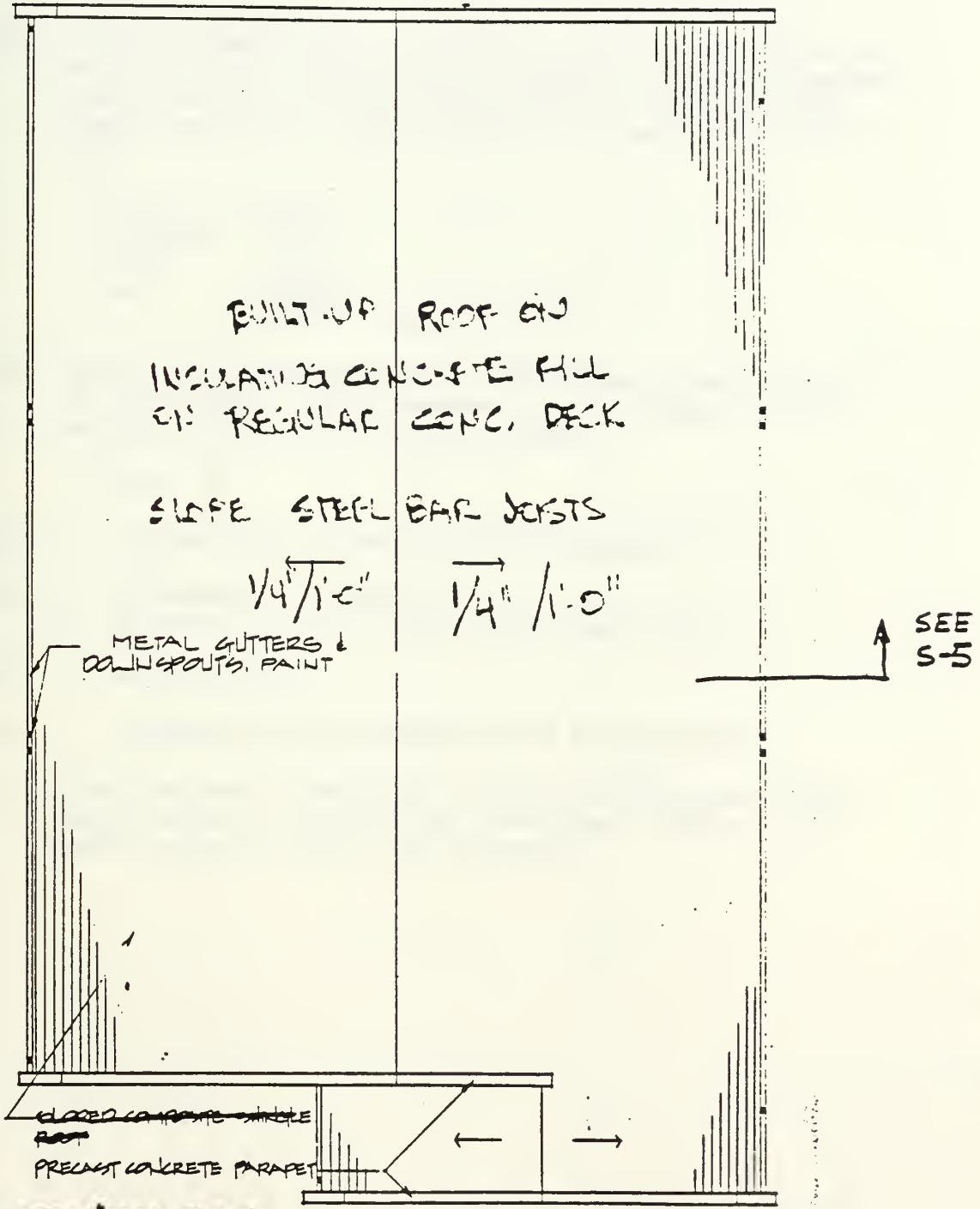

2 ROOF PLAN
A-A 1/8" = 1'-0"

VALUE ENGINEERING ALTERNATIVEE-14 Eliminate the Primary Fused Switch Unit for the 1,500 KVA Transformer - Site "B" (See Figures E-14 A and B)

As Designed: A 36 KV, fused switch is provided in the primary circuit in addition to the primary circuit breaker by the power company. Cost of switch, enclosure and bus is not itemized in 35% submittals, hence, costs from Westing House Catalog data is used.

Switch	\$4,255
Enclosure	1,230
Fuses	2,285
Bus	400
	<u>\$8,170</u> x 1.44 = \$11,765

Alternative: Eliminate the primary fused switch on the primary circuit. Use the primary circuit breaker by power company as the primary protection for the transformer.

Cost: \$0

Cost Savings: 1. Initial capital cost savings of \$11,765.

Advantages: 1. Performance unaffected.
2. Eliminates need to stock spare primary fuses.

Disadvantages: 1. None apparent.

Redesign: 1. Estimated redesign manhours is 8 MH professional.

Discussion: Since the primary switchgear with a circuit breaker by the power company is close to the transformer, another fused switch in the circuit is not necessary.

USE CIRCUIT BREAKER
 BY POWER COMPANY
 FOR PRIMARY PROTECTION

FIG. E-14B

ALTERNATIVE

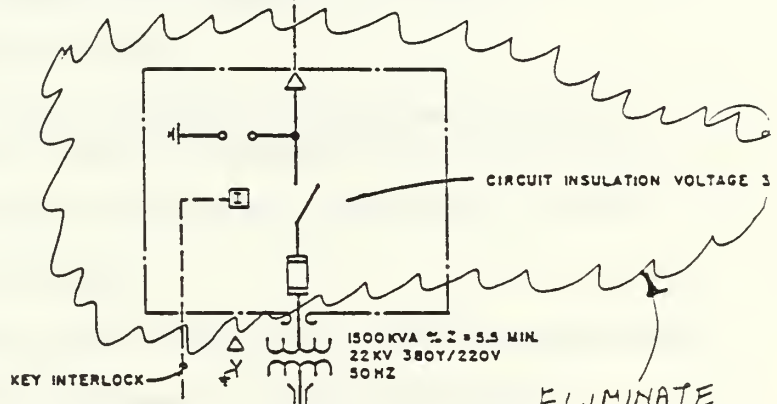
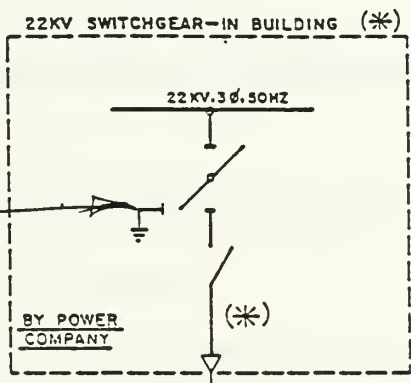

ELIMINATE SWITCH

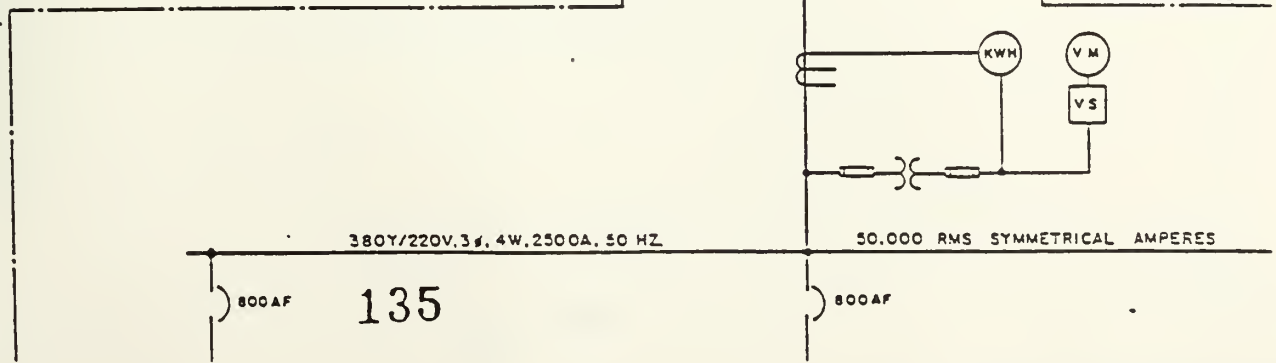
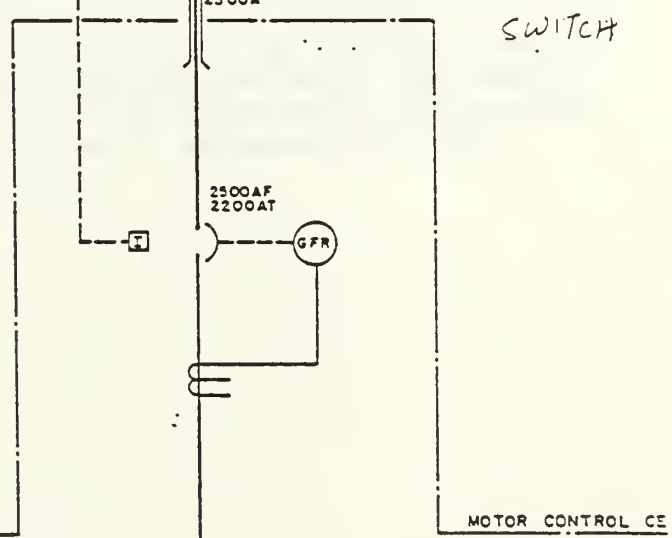

VALUE ENGINEERING ALTERNATIVEC-9 Raise Dike Height Around Tanks T-201 and T-202 at Site A
(See Figures C-9 A & B)

As Designed: Design consists of 1,640 lineal feet of 4.8' high dike. Dike is 3.28' wide at top side slopes of 2(H):1(V).

Cost: \$47,196 (See calculations)

Alternative: Alternate consists of 1,513 lineal feet of 6' high dike. Dike is 3.28' wide at top with side slopes of 2(H):1(V).

Cost: \$0 (See calculations)

Cost Savings: 1. Initial capital cost savings of \$47,200 derived from reducing perimeter of dike and related perimeter facilities.

Advantages: 1. Potentially reduced construction schedule due to smaller site area.
2. Performance unaffected.

Disadvantages: 1. Increased construction schedule due to extra concrete work.

Redesign: 1. Estimated redesign manhours is 16 MH professional.

Discussion: Alternate decreases area of dike as well as length of service road while remaining within guidelines of DM-22. May extend construction schedule slightly due to additional time required for concrete work. However, due to decreased site area, earthwork may not take as long.

A= DESIGNED

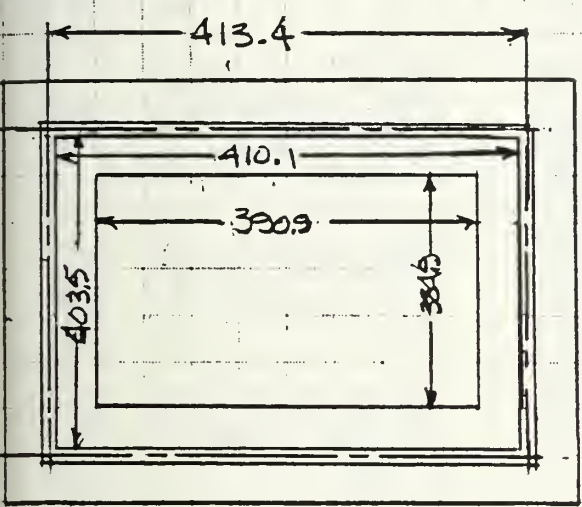

PLAN

PERIMETER = $(406.8 + 413.4)(2) \approx 1640$ L.F.
 EARTH VOLUME IN DIKE = $(1640)(61.6)/27 \approx 3742$ cu
 DIMENSIONS OF TOP OF INTERIOR FACE
 = $403.5 + 410.1$
 DIMENSIONS BOTTOM OF INTERIOR
 FACE 384.4×390.9
 AVG. DEPTH $4.73'$

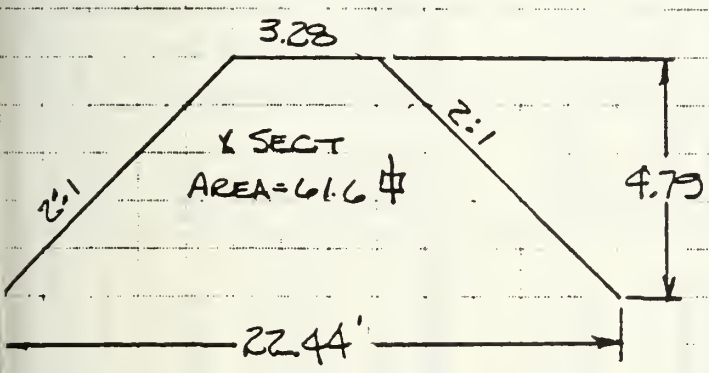

SECTION

Figure C-9A

PROJECT	ITEMS	LOCATION			MATERIAL COST		LABOR COST		TOTAL COST	COST REF. & PAGE #	PRELIM. <input type="checkbox"/> FINAL <input type="checkbox"/>
		QUANTITY	UNIT	UNIT	TOTAL	UNIT	TOTAL				
TANK AREA	SERVICE ROAD										
	CLEAR GRUB ROUTE (3" THICK)	169	S.Y.	—	—	0.92	99.71	99.71	99.71	ENG EST 10-91	
	DISPOSE GRUB MATERIAL	14	C.Y.	—	—	1.20	16.80	16.80	16.80	"	
	EXCAVATE FOR SUBGRADE COMPACT	47	C.Y.	—	—	0.18	8.46	8.46	8.46	"	
	COMPACT SUBGRADE	169	S.Y.	—	—	0.29	49.01	49.01	49.01	"	
	UNTREATED ROAD MATERIAL	47	C.Y.	6.4	312.00	0.82	41.34	41.34	353.44	"	
	GENERAL ROUTE GRADING/COMPACTING	47	C.Y.	—	—	0.88	41.36	41.36	41.36	"	
TANK AREA											
	CLEAR + GRUB AREA W/IN DIKE	2530	S.Y.	—	—	0.52	1402.70	1402.70	1402.70	ENG. EST 10-91	
	DISPOSE GRUB MAT'L.	211	C.Y.	—	—	1.20	253.20	253.20	253.20	"	
	BASEIN EARTHWORK (ADDITIONAL)	1395	C.Y.	—	—	0.12	167.40	167.40	167.40	"	
	DIKE + BERM EARTH CONSTRUCTION	1395	C.Y.	—	—	0.28	1227.60	1227.60	1227.60	"	
	BASEIN FINE GRADE + ROLL	3028	S.Y.	—	—	0.20	605.60	605.60	605.60	ENG EST 10-92	
	GEOMEMBRANE	3247	S.Y.	2.28	7403.16	—	—	—	7403.16	"	
	GEOMEMBRANE INSTALLATION	3247	S.Y.	—	—	0.64	2078.08	2078.08	2078.08	"	
	GEOTEXTILE OVERLAY	3247	S.Y.	1.52	4935.44	—	—	—	4935.44	"	
	GEOTEXTILE INSTALLATION	3247	S.Y.	—	—	0.50	1623.50	1623.50	1623.50	"	
	CONCRETE COSTS ADDITIONAL	(86)	(6.55)	3.2	(0.125)	—	10.83125	10.83125	1983.125	"	
	SAND COVER OVER MEMBRANE	505	C.Y.	5.84	2949.20	0.50	252.50	252.50	3201.70	"	
	STONE OVER SAND	677	C.Y.	7.81	5287.37	0.58	392.46	392.46	5679.83	"	
	SUBTOTAL						20887.28	20887.28	15,454.87		
	TOTAL WITH MARK-UP	(15,654.87)		(1.5074)					23,599.8	ENG EST 10-89	

APPENDIX B
VE JOB PLAN CHECKLISTS

TASKS TO BE PERFORMED

- **Select subject(s) for value analysis**
- **Be prepared to add further subjects arising out of Phase 3 (Function Analysis) and Phase 4 (Idea Generation).**

QUESTIONS TO BE ANSWERED

- **Where is major investment being directed?**
- **Do preliminary costs indicate any over-investment compared with norms?**
- **What are overall building functions?**

SELECTION PHASE CHECKLIST

Look for:

- inordinately expensive items
- anything complex
- innovative design
- construction difficulties
- multiple use items
- high maintenance cost
- operational difficulties
- critical material supply
- obsolete materials
- traditional repetitive thinking
- restrictive criteria
- safety factors
- spare capacity

PHASE 2
INFORMATION

TASKS TO BE PERFORMED

- Formalize client value objectives
- Gather data
- Organize data
- Prepare VM plan
- Organize workshops

QUESTIONS TO BE ANSWERED

- What is it?
- What does it do?
- What does it cost?
- What resources do we need for VA?
- What constraints apply?

PROCEDURES

- Get all the facts
- Get information from best sources
- Determine costs and allocate to functions
- Prepare energy model
- Document all findings (write it down)

INFORMATION PHASE CHECKLIST

- Establish client's value objectives
- Gather the following information:
 - Drawings
 - Specifications
 - Design criteria
 - Schedule
 - Existing cost estimates or contracts
 - Operations and maintenance cost data
 - Energy cost data
 - Previous studies
- Prepare cost estimate and sub-divide in form suitable for value analysis
- Establish life cycle cost criteria
- Set up schedule for VM workshops
 - Organize VM teams
 - Select dates
 - Prepare agenda
 - Prepare workbook

TASKS TO BE PERFORMED

- Review criteria and cost estimates
- Identify functions

QUESTIONS TO BE ANSWERED

- What does it do?
- What must it do?
- What is it worth?

PROCEDURES

- Identify functions
- Classify functions
- Set target worth
- Evaluate function-cost-worth relationships
- Refine scope of study for value improvement



FUNCTION ANALYSIS PHASE CHECKLIST

- Consider how it is being used, why someone wants it
- List all functions performed
- Determine basic and higher order functions
- Determine secondary or supporting functions
- Separate cost by functions
- Set target worth by function
(Use your past experience or by comparison with other items of known cost that provide a similar function or by relating to value objectives statement)
- Calculate value indices
- Analyze cost-worth relationship - consider:
 - Cost elements
 - Cost per action
 - Cost per parameter
 - Cost per use cycle
- Review for redundant functions
- Obtain more information, if necessary
- Ask these questions:
 - What does it do unnecessarily?
 - Do all functions contribute value?
 - Are the costs of the functions proportional to their usefulness?
- Select high cost functional areas for creating alternatives

TASK TO BE PERFORMED

- **Generate ideas**

QUESTION TO BE ANSWERED

- **What else will perform the function?**

PROCEDURES

- **Analyze, create, refine**
- **Exchange ideas**
- **Build on ideas**
- **Oversimplify**
- **Modify - combine ideas**
- **Freewheel**
- **Use creative thinking**
- **Use good human relations**

IDEA STIMULATOR CHECKLIST

ELIMINATE - COMBINE

- Can it be eliminated entirely?
- Can part of it be eliminated?
- Can two items be combined into one?
- Is there duplication?
- Can the number of different lengths, colors, types be reduced?

STANDARDIZE - SIMPLIFY

- Could a standard item be used?
- Would a modified standard item work?
- Does the standard contribute to cost?
- Does anything prevent it from being standardized?
- Is it too complex?
- Can interfaces be simplified?
- Is it over-detailed, over-specified or over-controlled?

CHALLENGE - IDENTIFY

- Does it do more than is required?
- Does it cost more than it is worth?
- What is special about it?
- Is it justified?
- Can tolerances be relaxed?

MAINTAIN - OPERATE

- Is it accessible?
- Are service calls excessive?
- Would you like to own it and pay for its maintenance?
- Is labour inordinate to the cost of materials?
- How often is it actually used?
- Does it cause problems?
- Have users established procedures to get around it?

REQUIREMENTS - COST

- Are any requirements excessive?
- Can less expensive materials be used?
- Is it proprietary?
- Are factors of safety too high?
- Are calculations always rounded off on the high side?
- Would lighter gauge materials work?
- Could a different finish be used?

TASKS TO BE PERFORMED

- To evaluate, criticize, and test the ideas generated during the speculation phase
- To estimate the cost of each idea
- To determine which idea offers best savings potential

QUESTIONS TO BE ANSWERED

- Will each idea perform the primary function?
- How feasible is each one?
- What will each idea cost?

PROCEDURES

- Compare ideas
- Refine; screen out those which cannot meet criteria
- Rank ideas for feasibility
- Put a dollar sign on all ideas
- Select preferred ideas for development
- Use experts for advice
- Use team judgment

- What ideas seem feasible?
- Did you evaluate all alternatives?
- Can any be modified or combined with another?
- Did you retain all feasible alternatives?
- What are the savings potential?
- What are the changes for implementation?
- What might be affected?
- Who might be affected?
- Will it be relatively difficult or easy to make a change?
- Will each idea satisfy user needs?

CONSIDER EVERYTHING!

BE REASONABLE!

SEEK THE BEST, NOT PERFECTION!

TASKS TO BE PERFORMED

- To select alternatives and prepare final recommendation for implementation

QUESTIONS TO BE ANSWERED

- What will the alternative(s) cost?
- Will the alternative(s) meet all necessary requirements?
- Are there implementation problems?

PROCEDURES

- Develop estimates
- Develop convincing facts
- Work on specifics - not generalities
- Develop required actions
- Select first and second choices
- Anticipate roadblocks
- Prepare written recommendations (VAP)

DEVELOPMENT PHASE CHECKLIST

- Will it satisfy the user's needs?
- Has technical adequacy been determined?
- Has life cycle cost impact been considered?
- Does any testing or development need to be accomplished?
- Are there any changeover or implementation problems?
- Does it have any impact on:
 - quality and reliability
 - safety and fire protection
 - procurement
 - the handicapped
 - the environment
 - maintenance and operations
 - energy consumption
 - documentation
 - legislation
- Would you approve it if it were your decision to make?
- Double check quantities and costs

TASKS TO BE PERFORMED

- Present proposed changes
- Sell proposed changes

QUESTIONS TO BE ANSWERED

- What is recommended?
- Who has to approve it?

PROCEDURES

- Give oral presentation
- Support it with completed workbook
- Be clear
- Be concise
- Be positive
- Anticipate roadblocks
- Use good human relations

PRESENTATION PHASE CHECKLIST

- Set a short time limit on your presentation
- Have back-up material available
- Select good presentation tools - overhead projector, flipchart, blackboard, even models or samples
- Carefully plan written and oral presentations

REFERENCES

1. Anglin, Howard E., Jr., and Gatley, Donald P., "High rising energy savings", American Society of Heating, Refrigeration, and Air-conditioning Engineers Journal, March 1985, pp. 56-58.
2. Bowen, Brian, "Maximizing the Effect of Value Engineering Units on Building Construction Projects", SAVE Proceedings, 1984, pp. 137-142.
3. Cantrell, Robert J., "A Linear Approach to Value Engineering of A Construction Project (A Journey)", SAVE Proceedings, 1982, pp. 1-8.
4. Chamberland, Thomas R., "Modeling Techniques", SAVE Proceedings, 1983, pp. 1-14.
5. Chamberland, Thomas R., "VE Does Save", SAVE Proceedings, 1984, pp. 1-10.
6. Charette, Robert P., "Criteria Definition of Building Energy Systems", SAVE Proceedings, 1980, pp. 13-28.
7. Charette, Robert P., "The Test Reference (TRB) Building Concept for VE Application", SAVE Proceedings, 1981, pp. 65-82.
8. Childs, Harvey C., "Win- Win- Win, School Construction in Washington State", SAVE Proceedings, 1984, pp. 11-13.
9. Chilstrom, Allan L., "An Approach to VE Project Management", SAVE Proceedings, 1983, pp. 75-82.
10. Cook, Thomas F., "Welcome to Value Analysis and Value Engineering", SAVE Proceedings, 1984, pp. 75-82.
11. Creasy, Q. R., "Problem Solving - The F.A.S.T. Way", SAVE Proceedings, 1980, pp. 173-176.
12. Dandri, Guido, and Patrone, Pietro, "Pareto's Law and Value Analysis in Construction", SAVE Proceedings, 1982, pp. 9-14.
13. Dell'Isola, Alphonse J., Value Engineering in the Construction Industry, Van Nostrand Reinhold Company, New York, NY, 1982.
14. Dell'Isola, Alphonse J., "Value Engineering Application to Airport Facilities", SAVE Proceedings, 1984, pp. 178-186.
15. Dell'Isola, Alphonse J., "A Value Engineering Case Study", Heating, Piping & Air Conditioning, June 1970, pp. 50-54.
16. Dell'Isola, Alphonse, J., "Cost Modeling - Procedures for Establishing Target Cost", SAVE Proceedings, 1980, pp. 109-120.

17. Denyes, Jim, "Creative Problem Solving Critical Examination Sheet", SAVE Proceedings, 1983, pp. 143-148.
18. Department of Defense, Value Engineering, DOD 4245.8-H, March 1986.
19. Fiorelli, James A., "Criteria Weighting: The Right To Be Right", SAVE Proceedings, 1981, pp. 105-109.
20. Fiorelli, James A., "Ask The Right Question; Solve The Right Problem", SAVE Proceedings, 1983, pp. 83-88.
21. Fowler, Theodore C., "The 'User-Oriented' FAST Diagram", SAVE Proceedings, 1983, pp. 89-94.
22. Kaufman, J. Jerry, "Understanding The Problem Before You Work The Solution", SAVE Proceedings, 1983, pp. 95-108.
23. Keener, Richard M., "Diagram Cost Model Functionally", SAVE Proceedings, 1981, pp. 110-114.
24. Kelly, William L., "Willow Creek Dam, A Survivor", SAVE Proceedings, 1984, pp. 168-178.
25. Khashab, A. M., Heating, Ventilation, and Air-Conditioning Systems Estimating Manual, McGraw-Hill, Inc., New York, NY, 1984.
26. Kirk, Stephen J., "Value Assesment in Facilities Design, Multi-Value Indices", SAVE Proceedings, 1981, pp. 58-64.
27. Korta, Lawrence B., "Creative Problem Solving Workshop", SAVE Proceedings, 1983, pp. 170-171.
28. Kuykendall, Richard C., "Value-Purchasing", SAVE Proceedings, 1983, pp. 109-114.
29. Larsen, Melvin B., "Value Engineering or Creative Management", SAVE Proceedings, 1983, pp. 20-22.
30. Macedo, Manuel C., Jr., and Dobrow, Paul V., and O'Rourke, Joseph J., Value Management for Construction, John Wiley & Sons, Inc., New York, NY, 1978.
31. Miles, Lawrence D., Techniques of Value Analysis and Engineering, McGraw-Hill Company, Inc., New York, NY, 1972.
32. Miles, Larry D., "Value Analysts - Teaching Your People to Buy Functions to Offset Inflation", SAVE Proceedings, 1980, pp. 65-68.
33. Naval Facilities Engineering Command, Executive Briefing: Value Engineering, U.S. Cost, Inc., Atlanta, GA, 1985.
34. Naval Facilities Engineering Command, Naval Facilities Engineering Command Value Engineering Program, NAVFACINST 4858.1C, April 1983.

35. Naval Facilities Engineering Command, Value Engineering Report: Submarine Training Building (P-116) Naval Guided Missile School, U.S. Cost, Inc., Atlanta, GA, 1986.
36. Naval Facilities Engineering Command, Value Engineering Report: Applied Instruction Buildings (P-821), Hanscomb Associates, Inc., Atlanta, GA, 1986.
37. Naval Facilities Engineering Command, Value Engineering Report: Aircraft Maintenance Hanger Naval Air Station, Oceana, Virginia Beach, Virginia, Arthur Beard Engineers, Inc., Vienna, GA 1985
38. Naval Facilities Engineering Command, Value Engineering Report: Bachelor Enlisted Quarters, Portsmouth, Virginia, Edward J. Nichols and Associates, Inc., Alexandria, Virginia, 1986.
39. Naval Facilities Engineering Command, Value Engineering Report: POL Resupply Facilities, Sites A and B, North Africa, Edward J. Nichols and Associates, Inc., Alexandria, Virginia, 1986.
40. O'Brien, James J., Value Analysis in Design and Construction, McGraw-Hill, Inc., New York, NY, 1976.
41. Parker, Donald E., "Cost Models for Applied Value Engineering", SAVE Proceedings, 1984, pp. 32-39.
42. Peters, Herbert, "The Mechanical Engineer In Value Engineering", SAVE Proceedings, 1984, pp. 40-49.
43. Puscas, Elena, and Pascu, Anca, and Suditu, Constantin, "Multicriteria Decision Making In Construction", SAVE Proceedings, 1983, pp. 23-26.
44. Rushbrook, Edward L., Jr., "Value Engineering of the Claremont, NH Wastewater Treatment Facility", SAVE Proceedings, 1983, pp. 28-34.
45. Sandberg, H. R., and Grammer, D., "Planning Thru Value Engineering", SAVE Proceedings, 1983, pp. 44-52.
46. Schliebe, Ronald, "The Problem/Solution Matrix", SAVE Proceedings, 1984, pp. 135-139.
47. Shuey, Ralph A., "V.E. and Energy", SAVE Proceedings, 1980, pp. 69-76.
48. Southern Division Naval Facilities Engineering Command, Value Engineering Change Proposals under Construction Contracts, SOUTHNAVFACINST 4858.1C, October 1981.
49. Suhr, Jim, "A Conversation About The Tradeoff Evaluation Process", SAVE Proceedings, 1984, pp. 94-105.
50. Turner, O. D., and Hansen R. J., Value Engineering in Preconstruction and Construction, National Cooperative Highway Research Program, Washington, DC, 1981.

51. Vernon, Norman M., "Value Analysis - A Purchasing Technique", SAVE Proceedings 1981, pp. 8-12.
52. Zimmerman, Larry W., and Hart, Glen D., Value Engineering: A Practical Approach for Owners, Designers, and Contractors, Van Nostrand Reinhold Company, New York, NY, 1982.

218800

Thesis
L836 Loveless
c.1 Value engineering in
the construction pro-
cess.

218800

Thesis
L836 Loveless
c.1 Value engineering in
the construction pro-
cess.

Value engineering in the construction pr



3 2768 000 67106 9

DUDLEY KNOX LIBRARY