

2015/15103
: 12

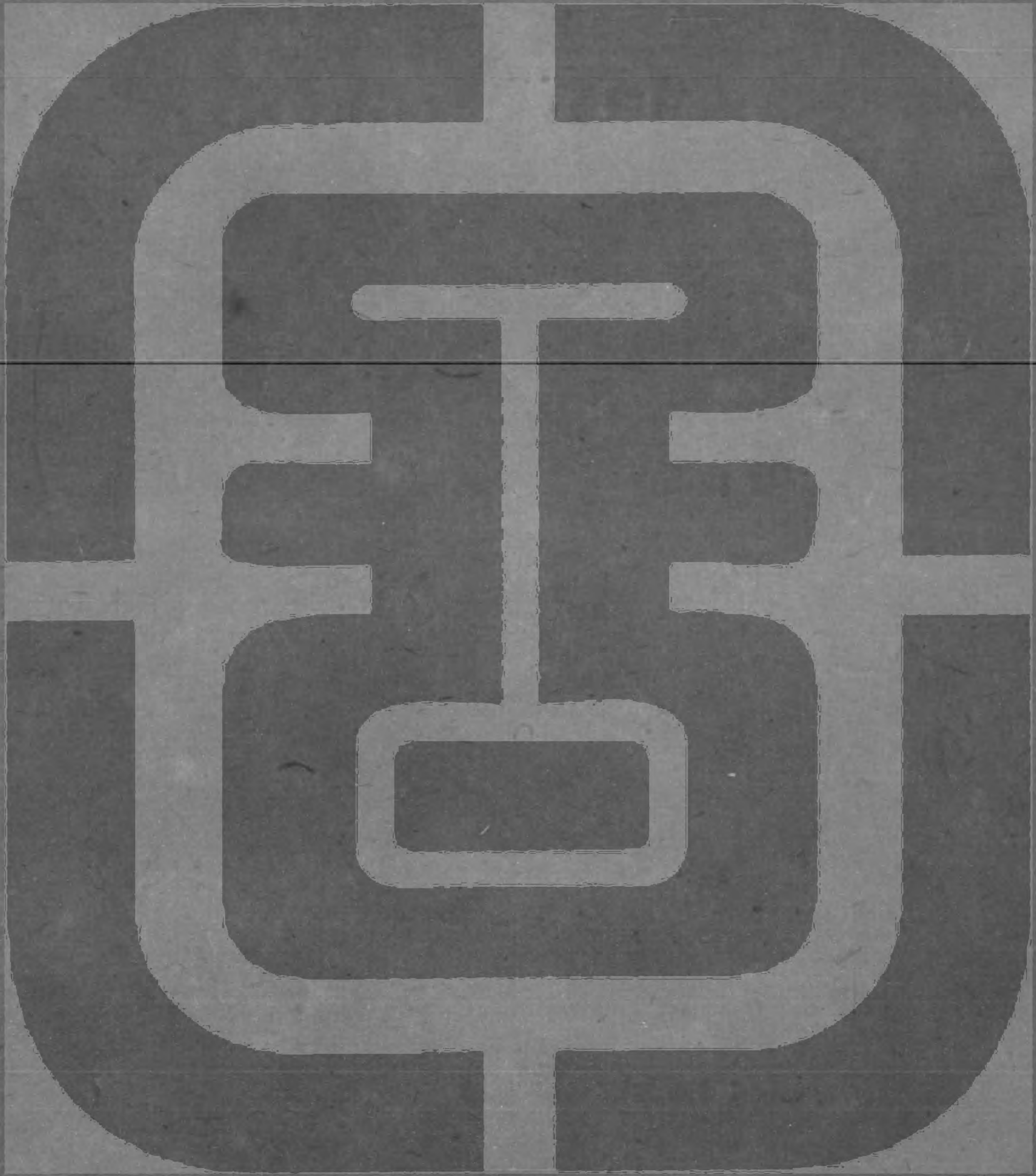



圭璧璋瓚繅藉制圖

大圭



大圭長三尺杼上終葵首天子服之

駟琮

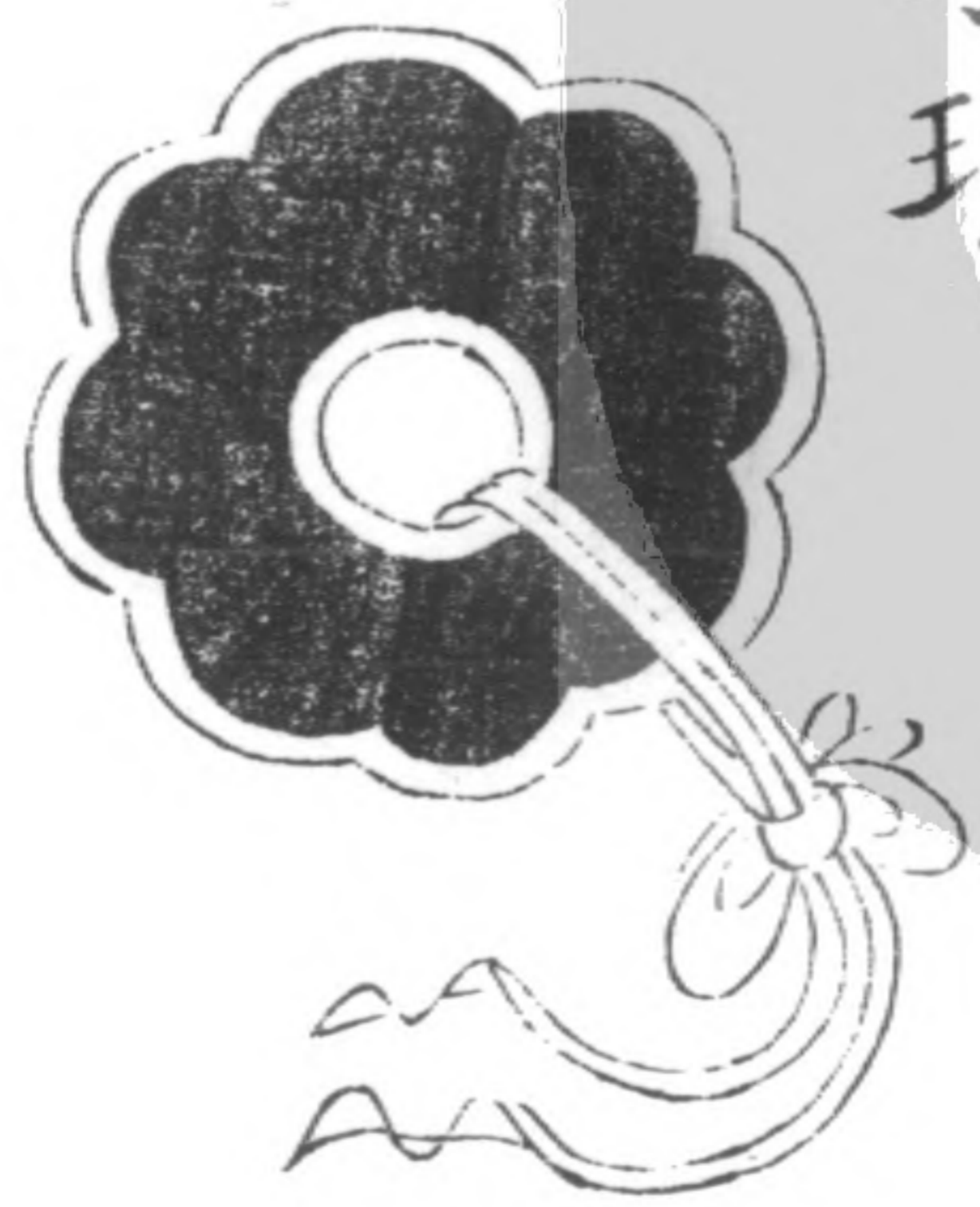

以組繫琮因名之天子宗后以為權

兩圭有邸 色青

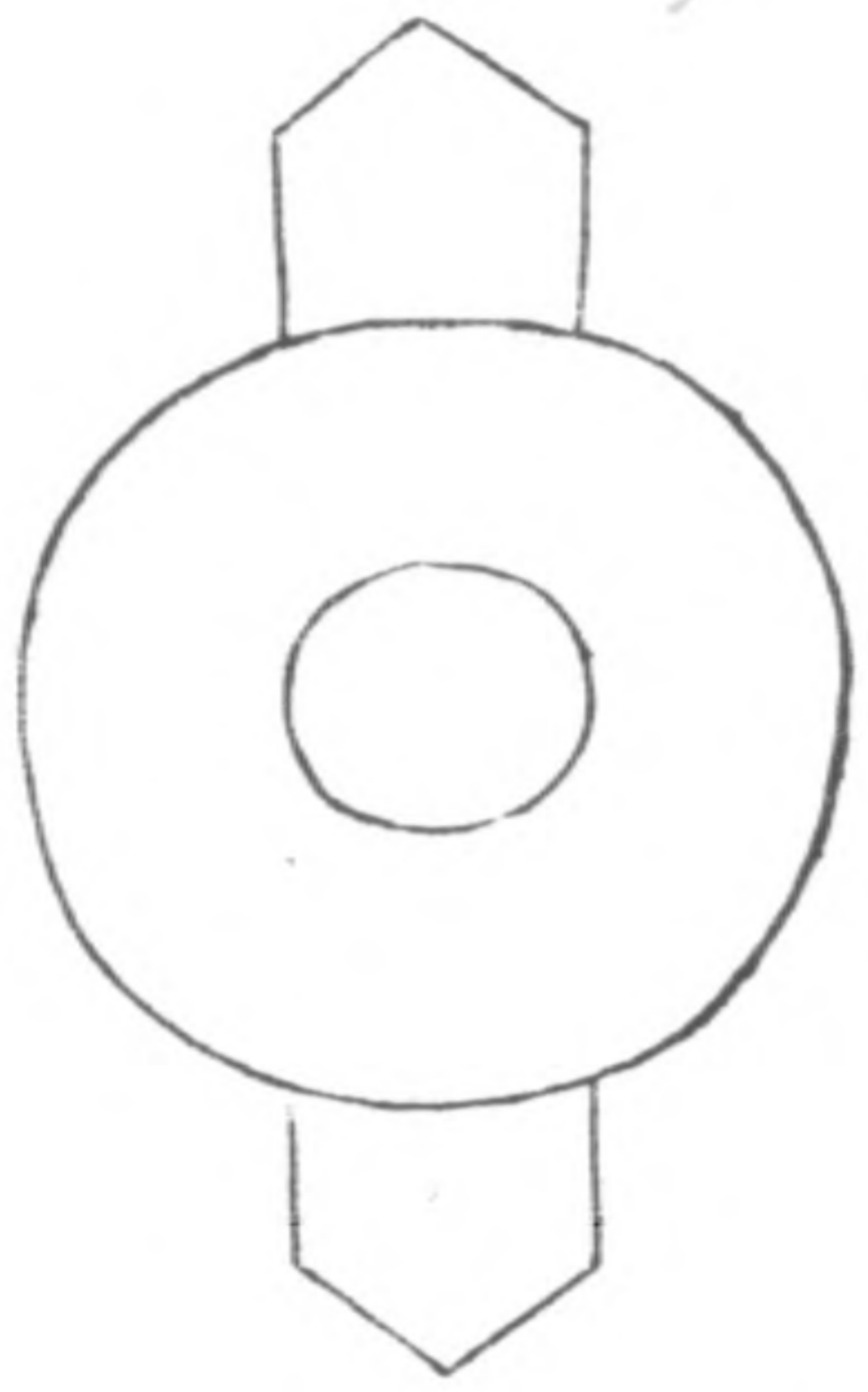

典瑞兩圭有邸以祀地旅四望玉人兩圭五寸有邸

冒

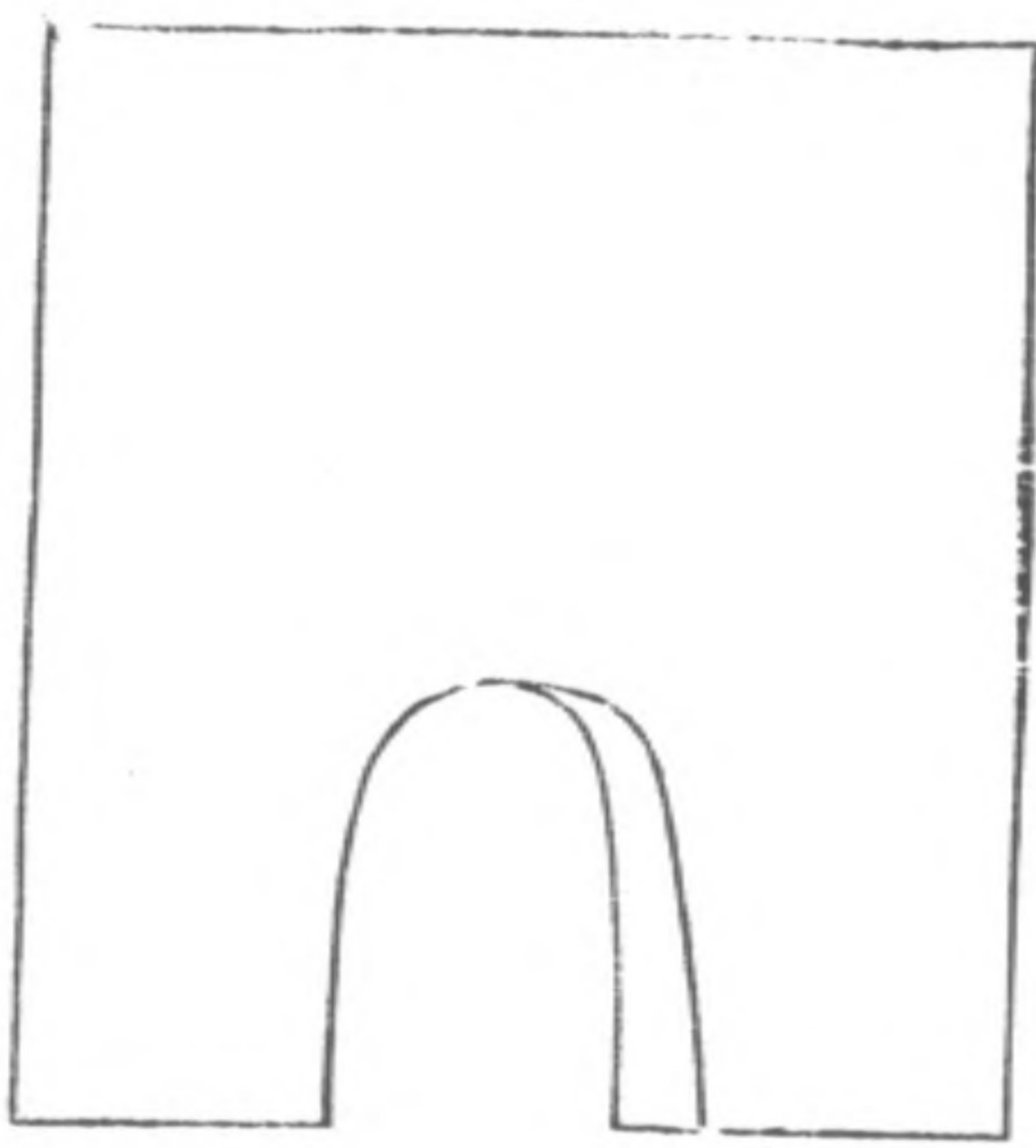

天子執冒四寸以朝諸侯



大琮

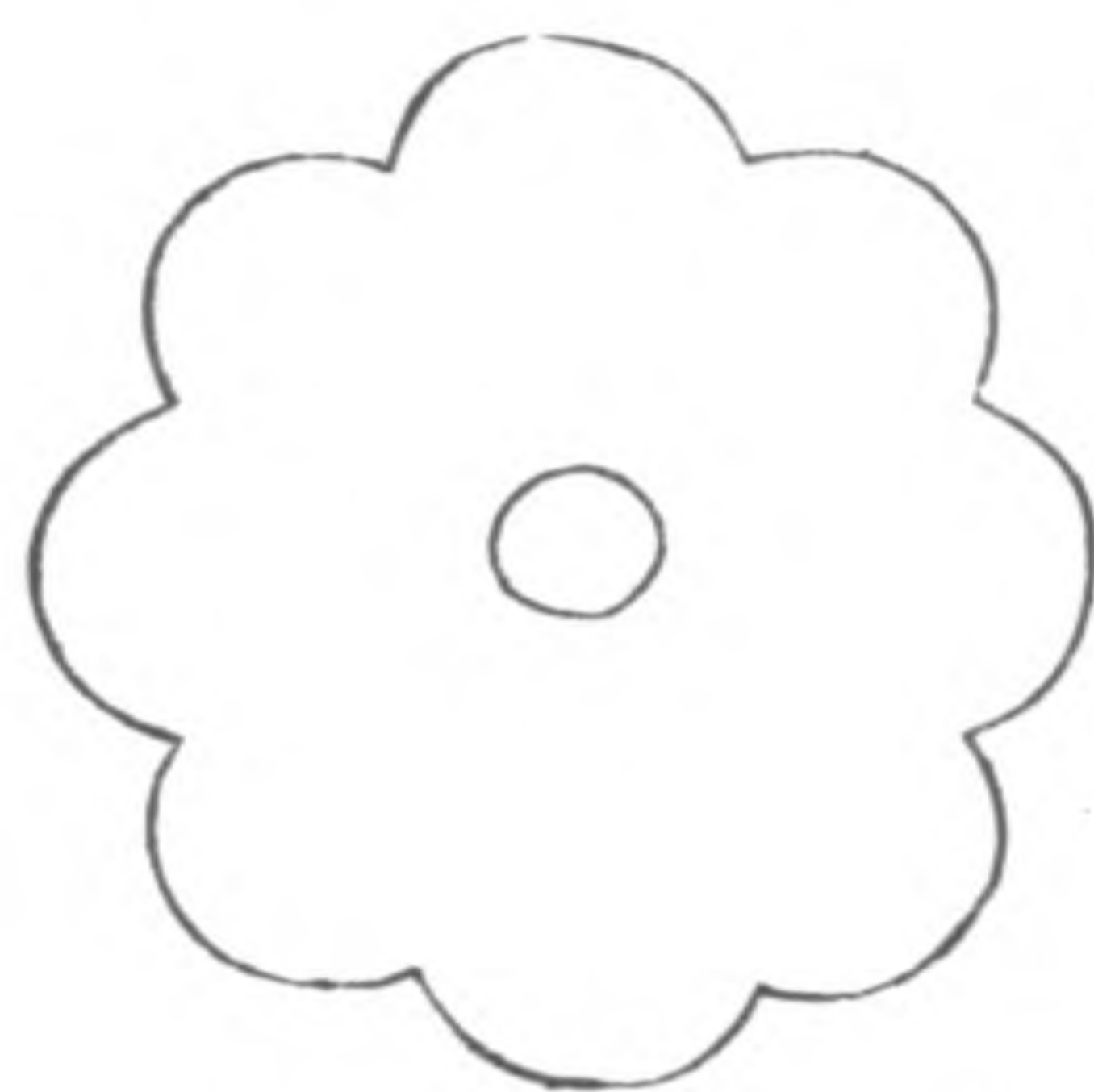

尺有二寸射四寸厚寸是謂內鎮宗后守之

圭璧

色白

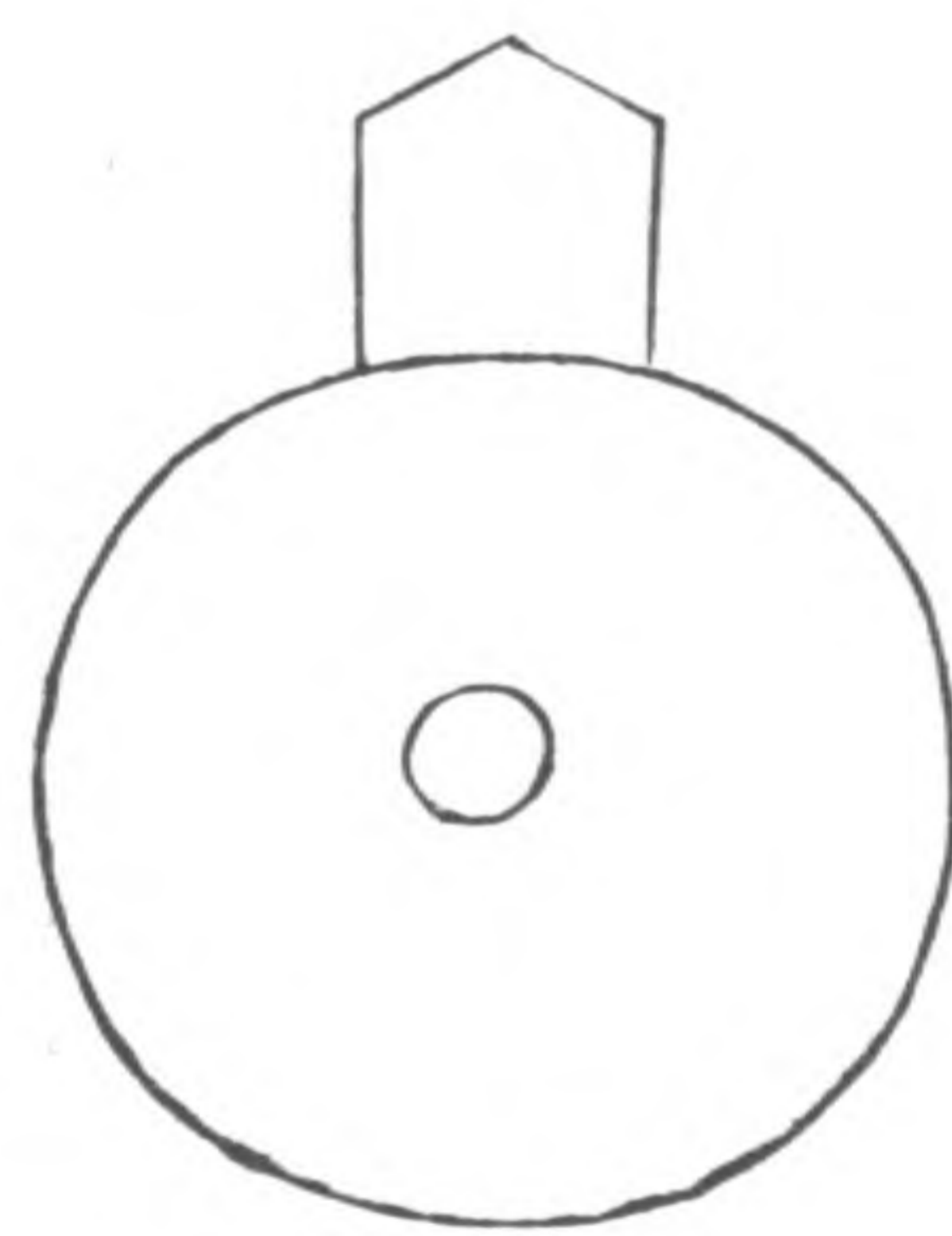

以祀日月星辰璧六寸壁上琢出一圭長五寸

鎮圭



鎮圭以四鎮山為琢飾故以鎮為名

琬圭

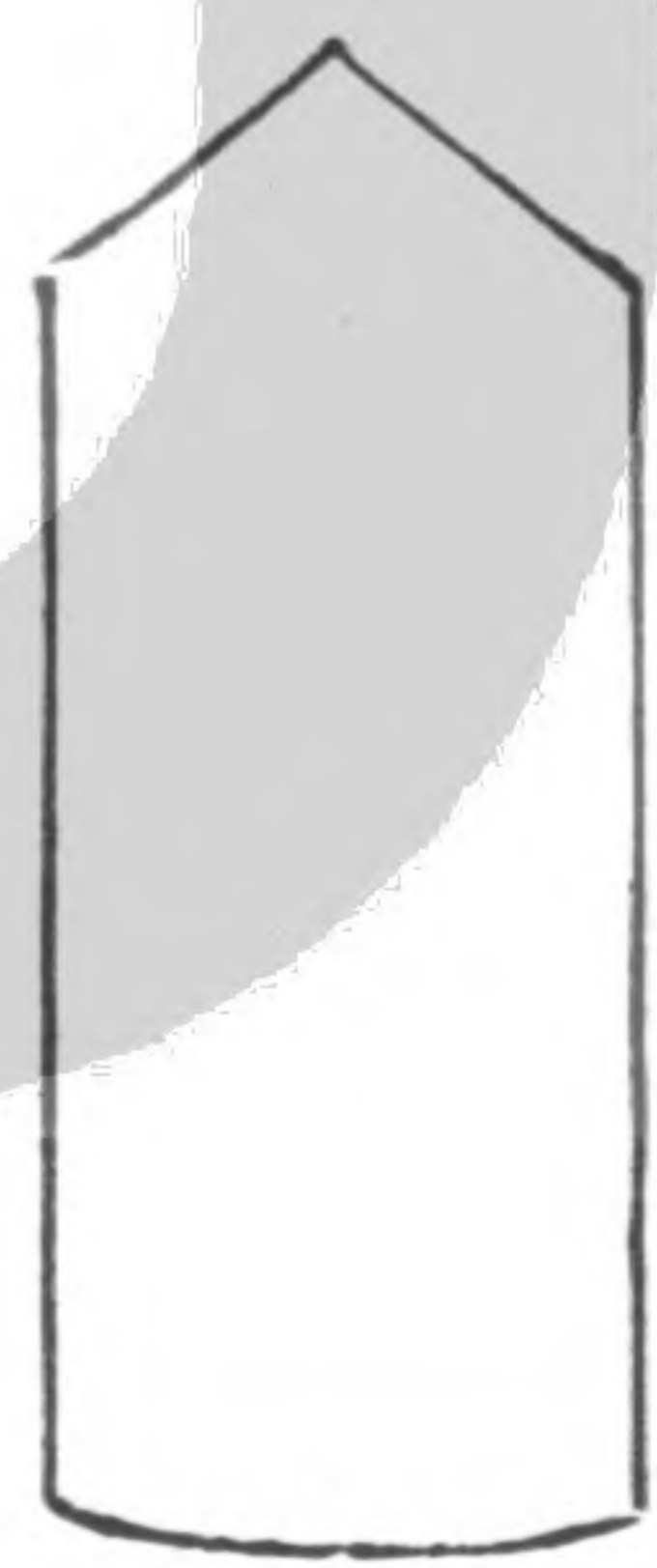

琬圭九寸以治德以結好琬猶圈也

璋邸射

色白

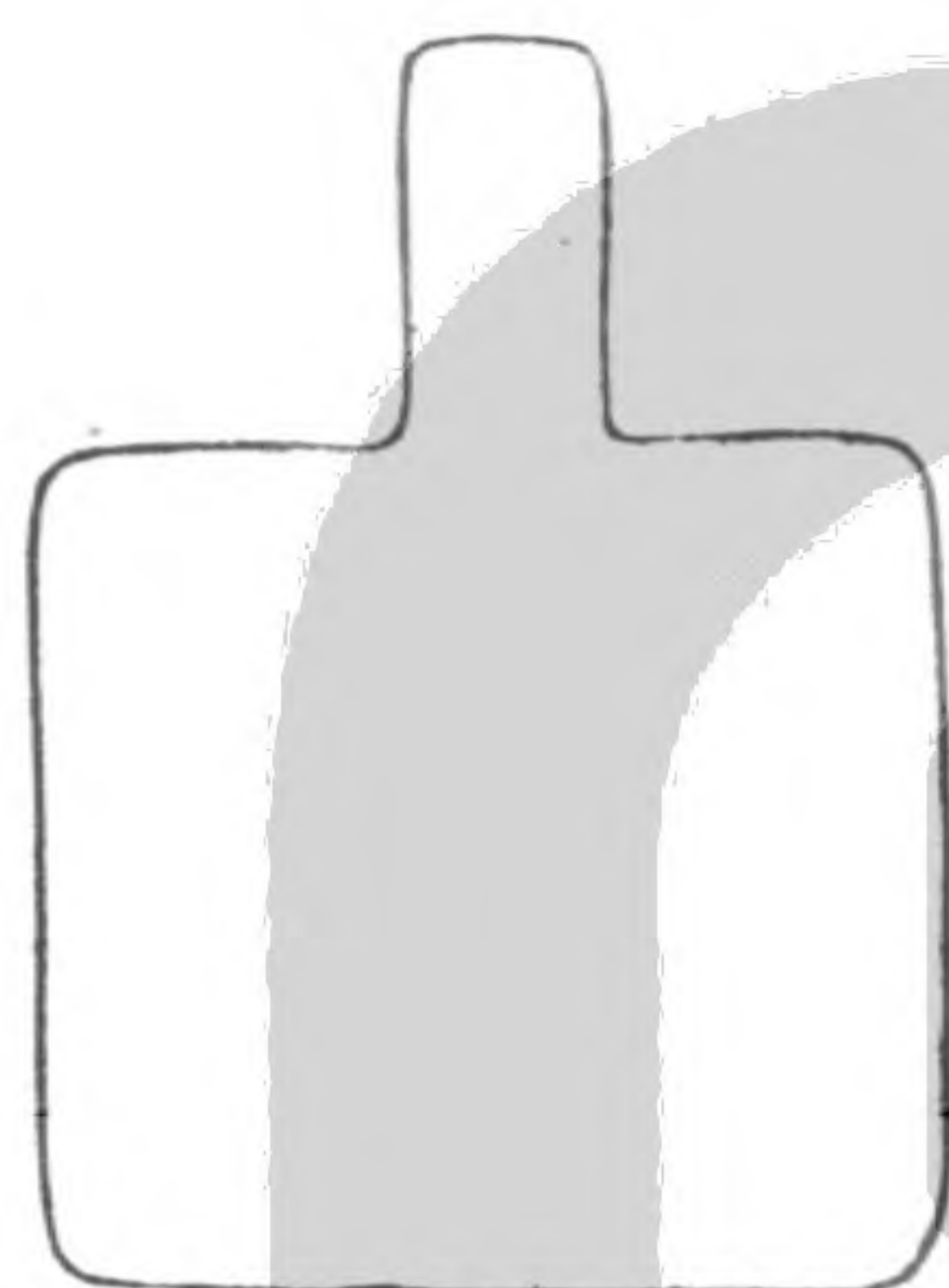

以祀山川半圭曰璋從下自邸嚮上邪卻之曰邸射

桓圭



命圭九寸曰桓圭公守之

琰圭



琰圭九寸判規以易行以除慝

圭瓚

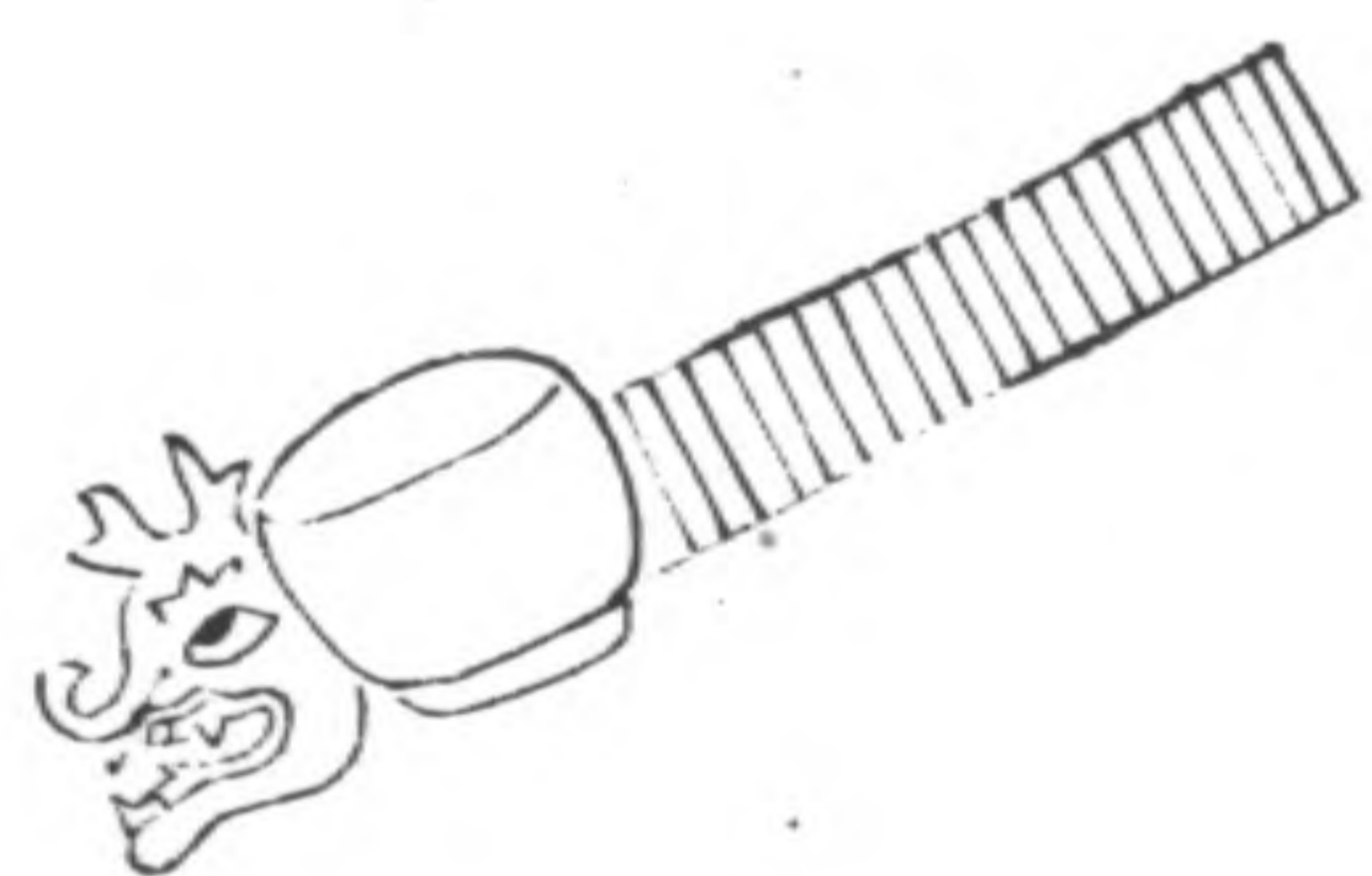

裸圭尺有二寸有瓚以祀廟瓚如槃大五升口徑八寸深二寸其柄用圭有流

信圭



信圭象以
人形為琢
飾為信耳

蒼璧

色青

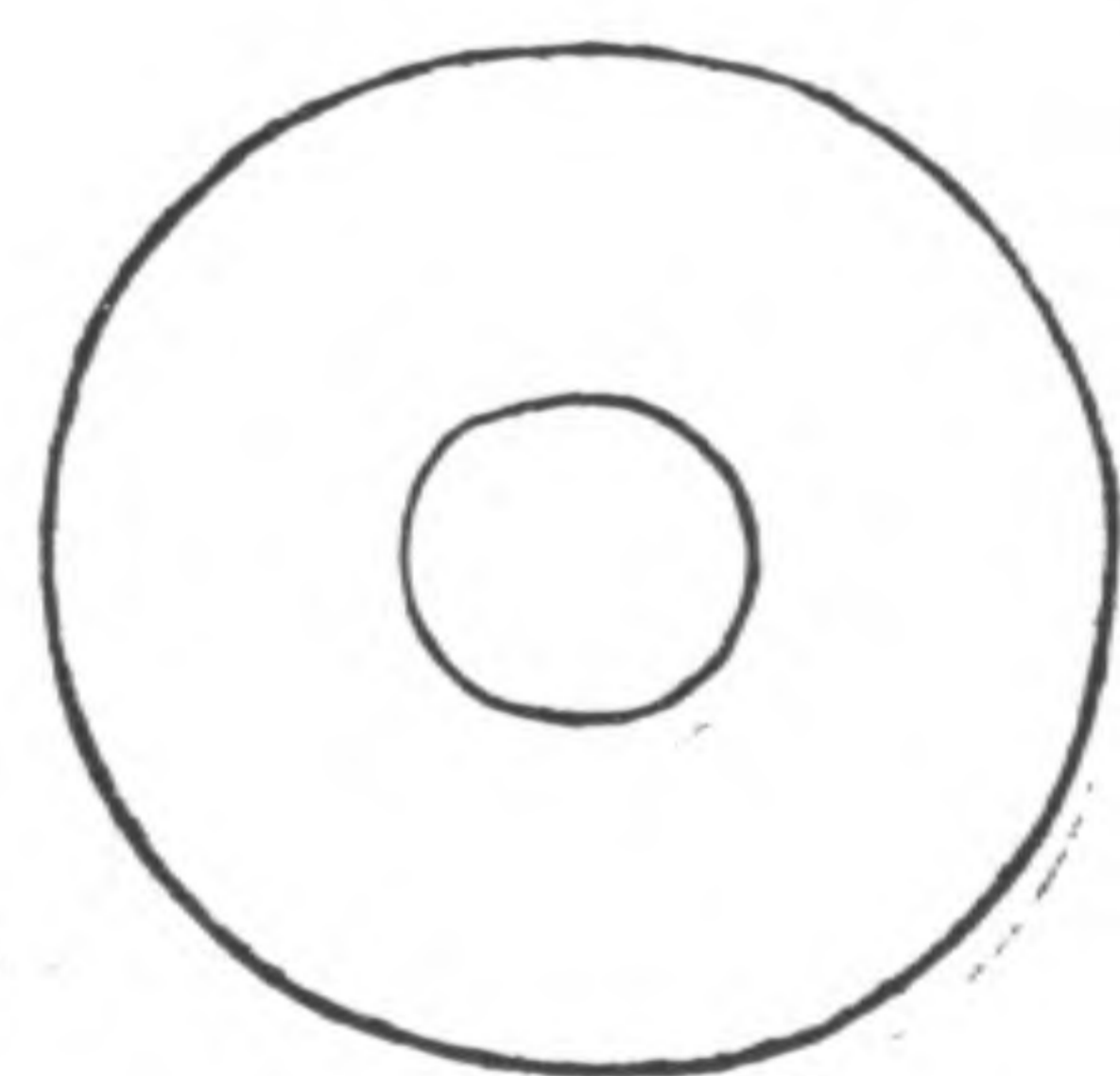

蒼璧禮天
徑九寸好
三寸兩邊
各三寸

中璋瓚

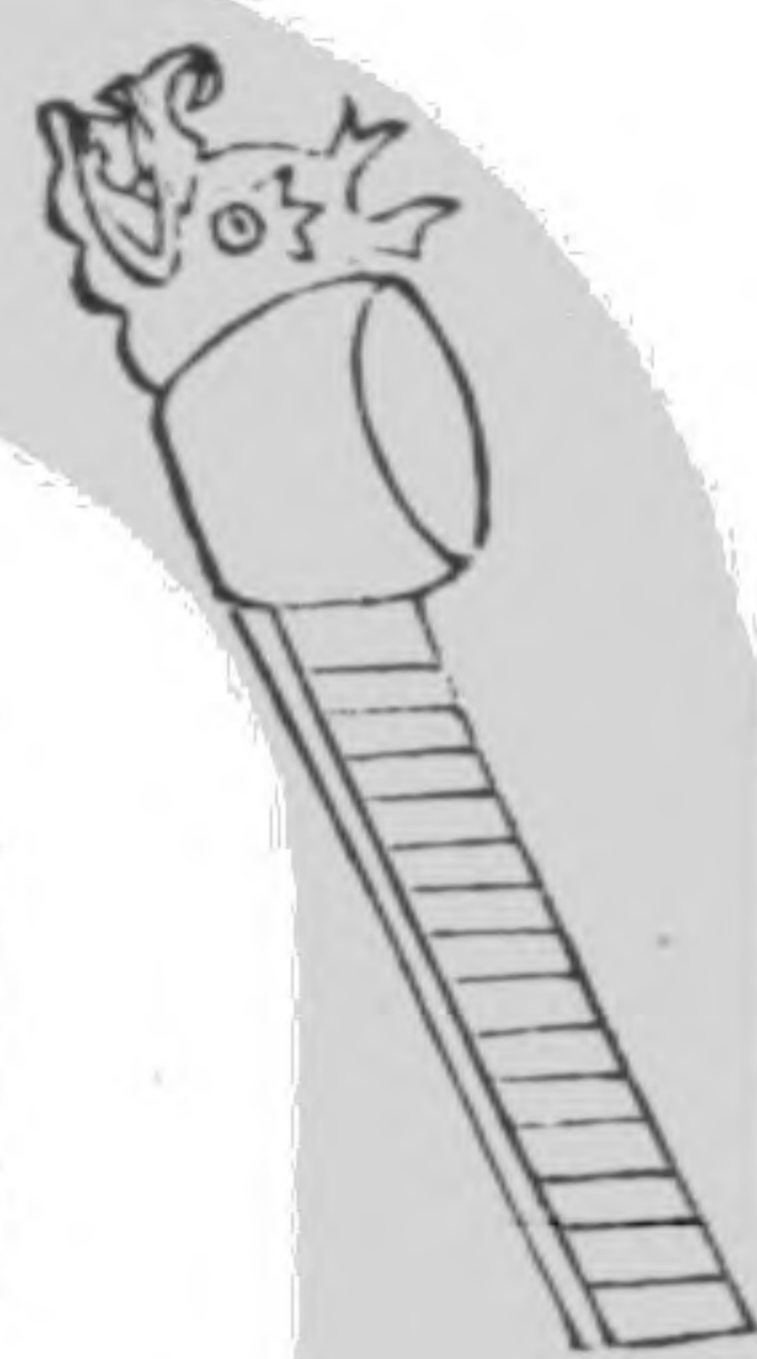

中璋九寸
制如大璋
天子巡守
所過中山
川用禮其
神

躬圭



躬圭象以
人形為琢
飾為躬耳

黃琮
色黃

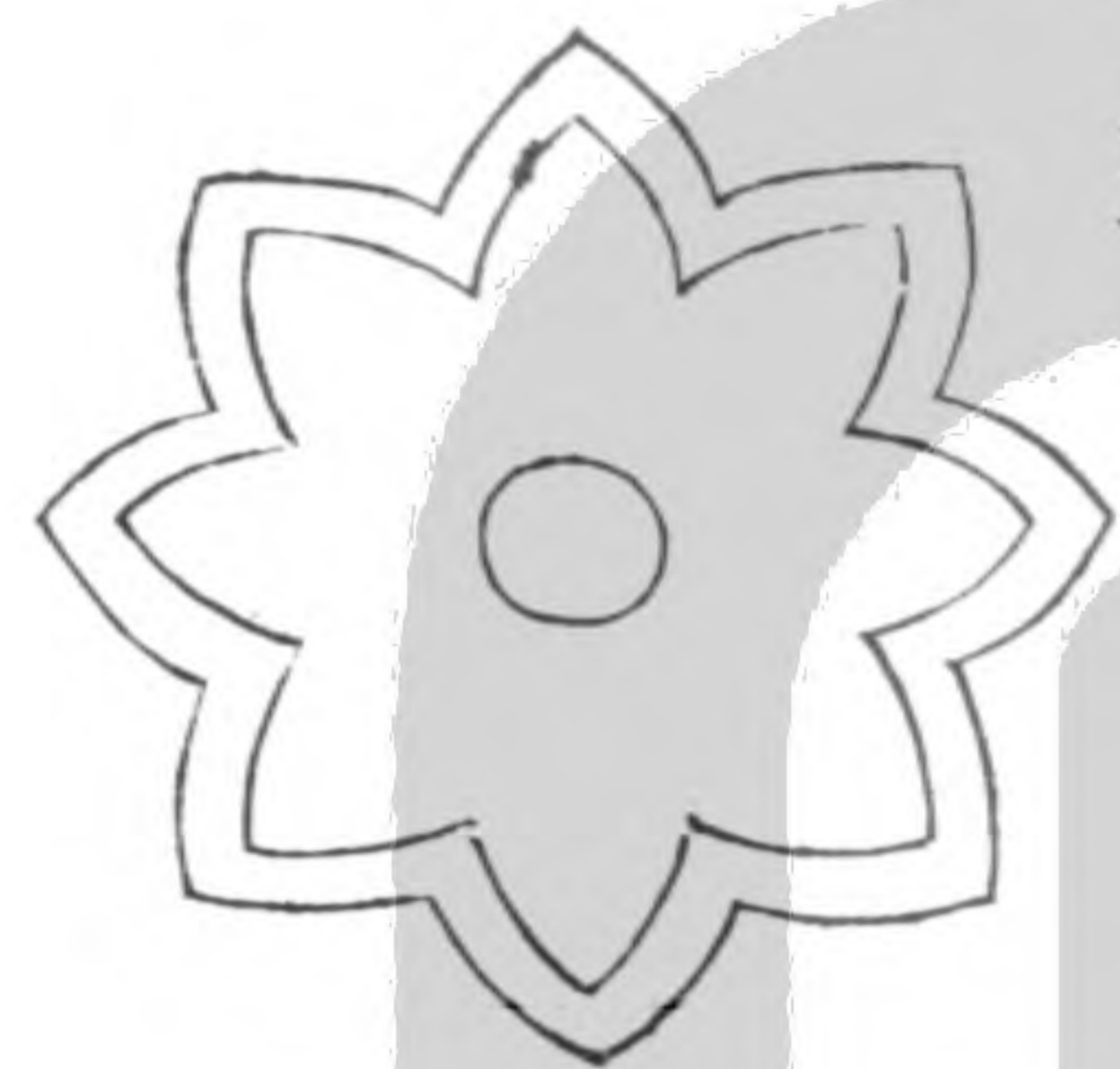

黃琮禮地
剡出一寸
六分長八
寸厚寸

邊璋

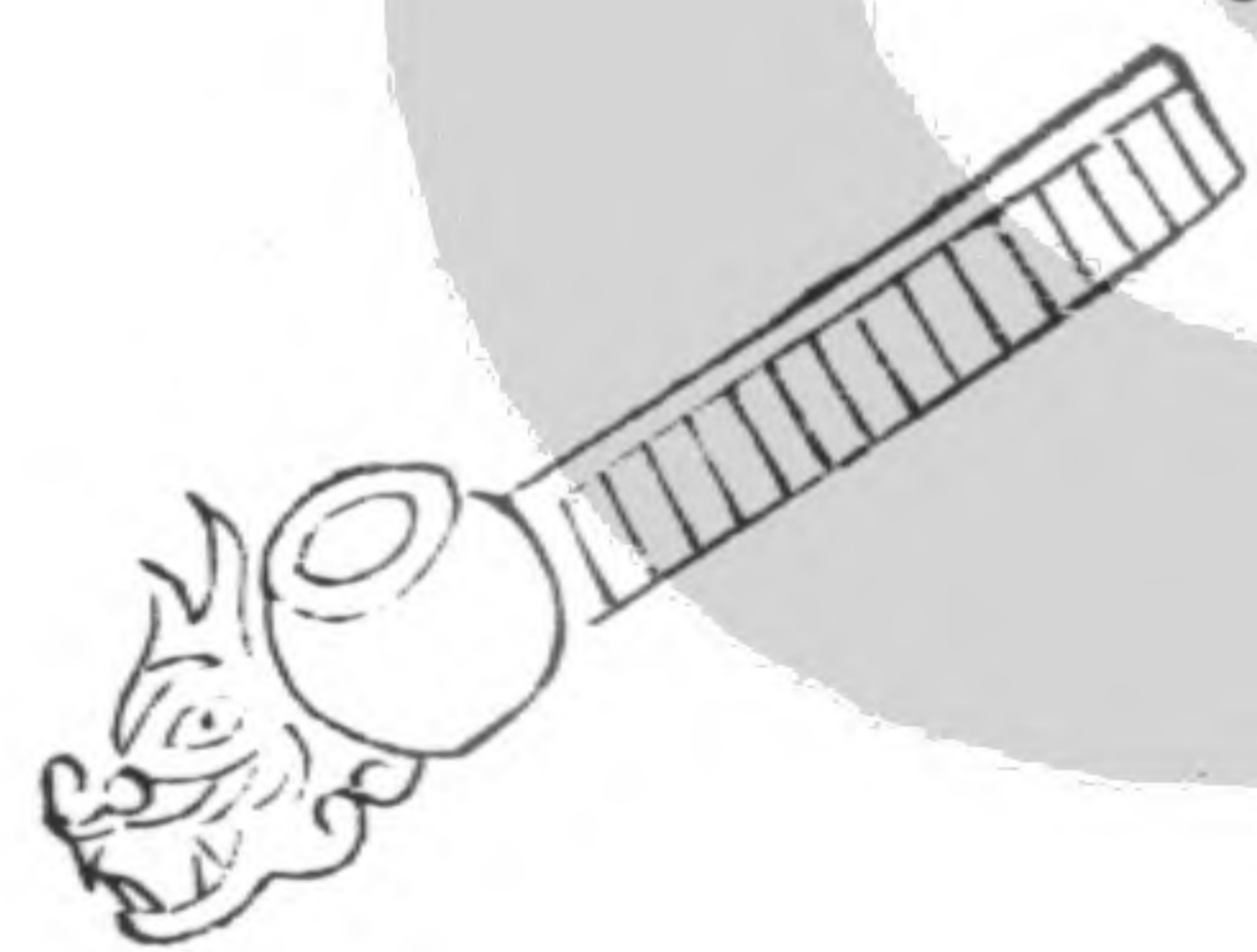

邊璋七寸
制如大璋
天子巡守
所過小山
川用禮其
神

穀璧



琢穀稼之
形為飾五
寸子執之

青圭
色青

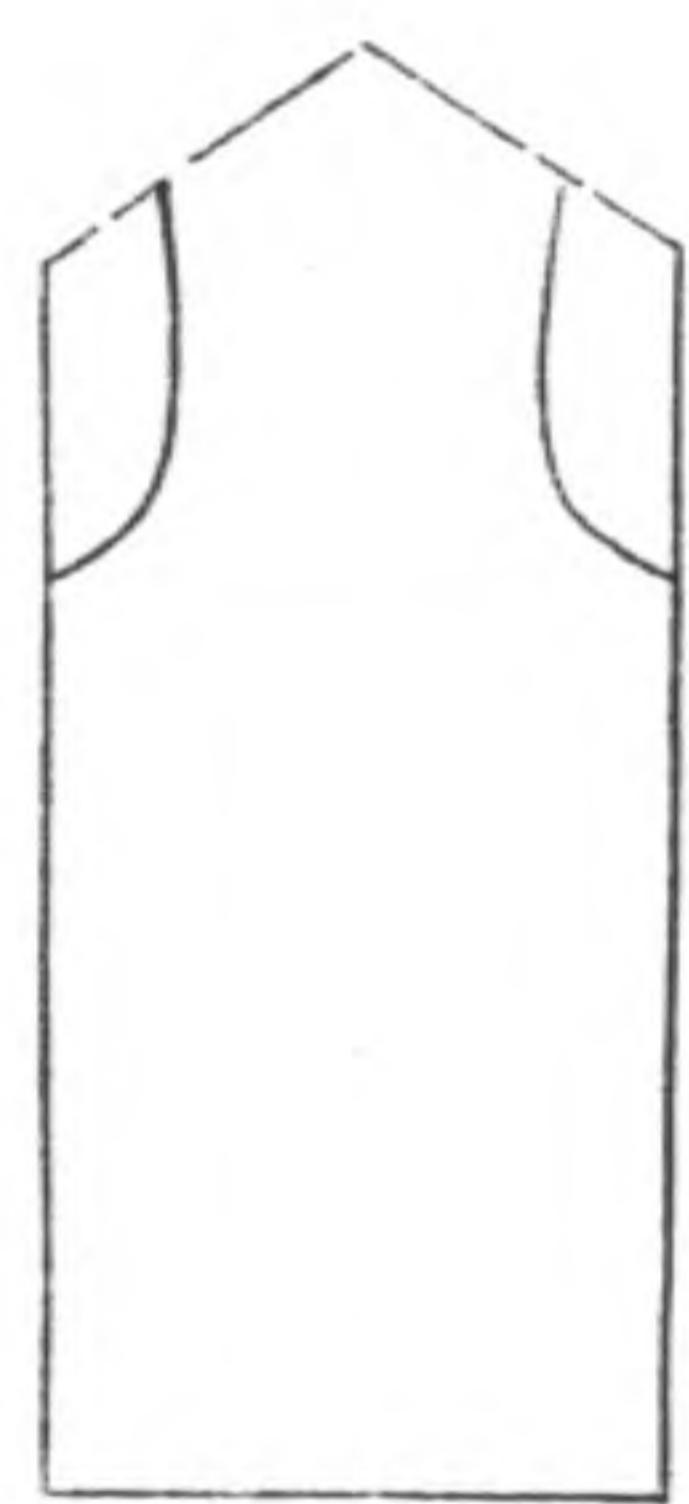

青圭禮東
方圭九寸
厚寸博三
寸剡上各
一寸半

璧羨

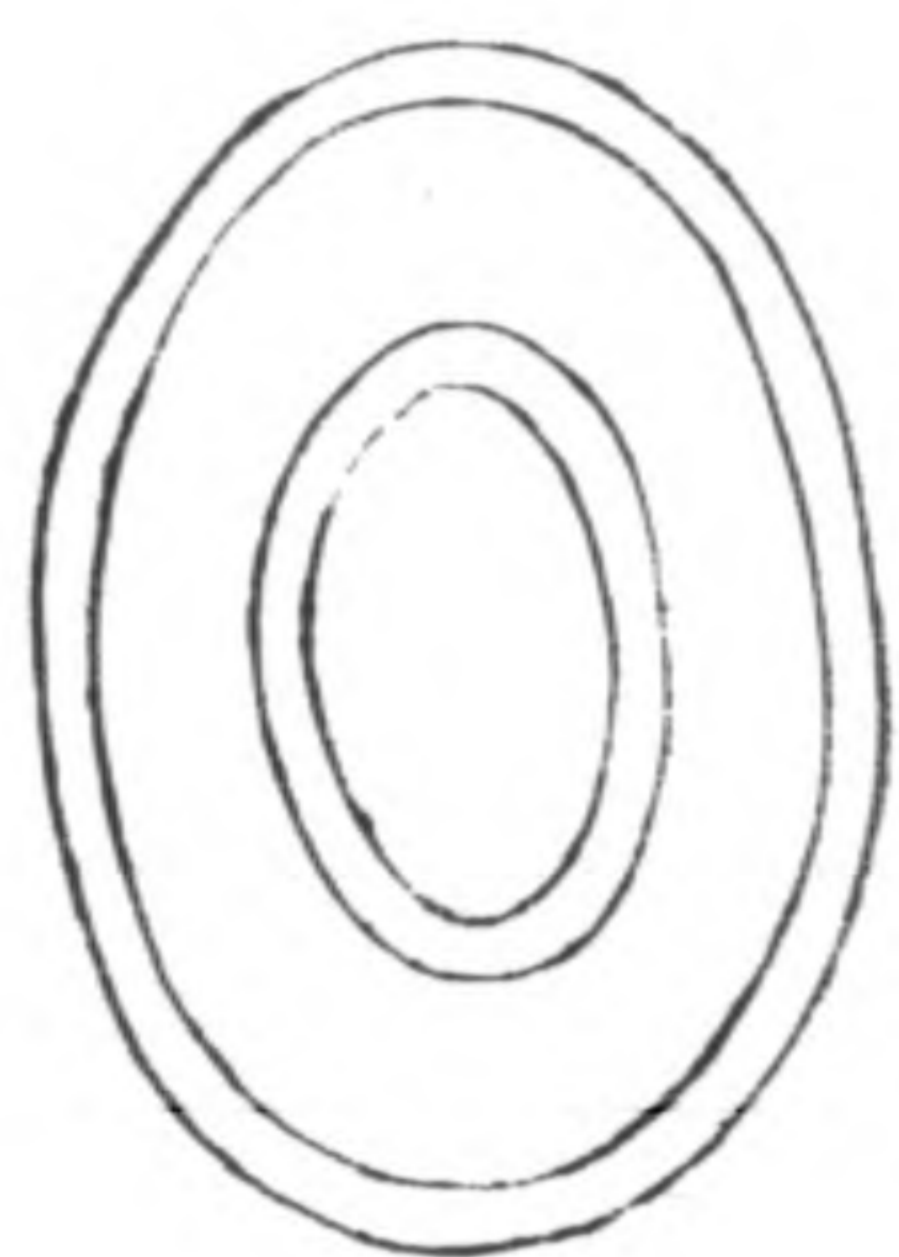

璧羨度尺
好三寸以
為度羨徑
也好孔也

蒲璧



琢蒲草之
形為飾五
寸男執之

赤璋 色赤

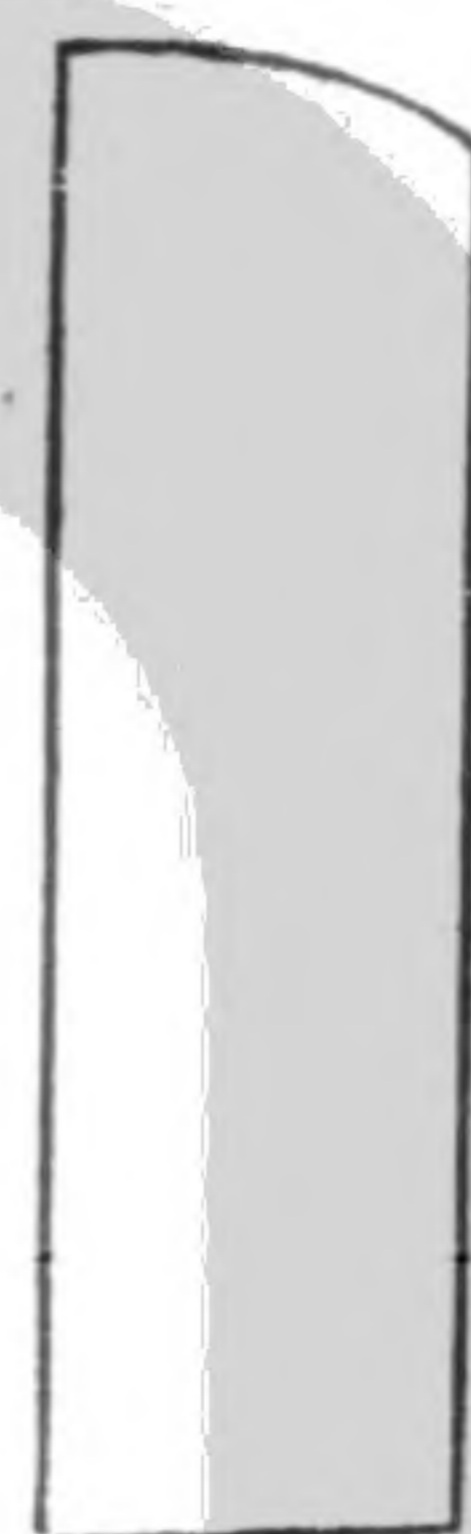

赤璋禮南
方半圭曰
璋

王者繅藉

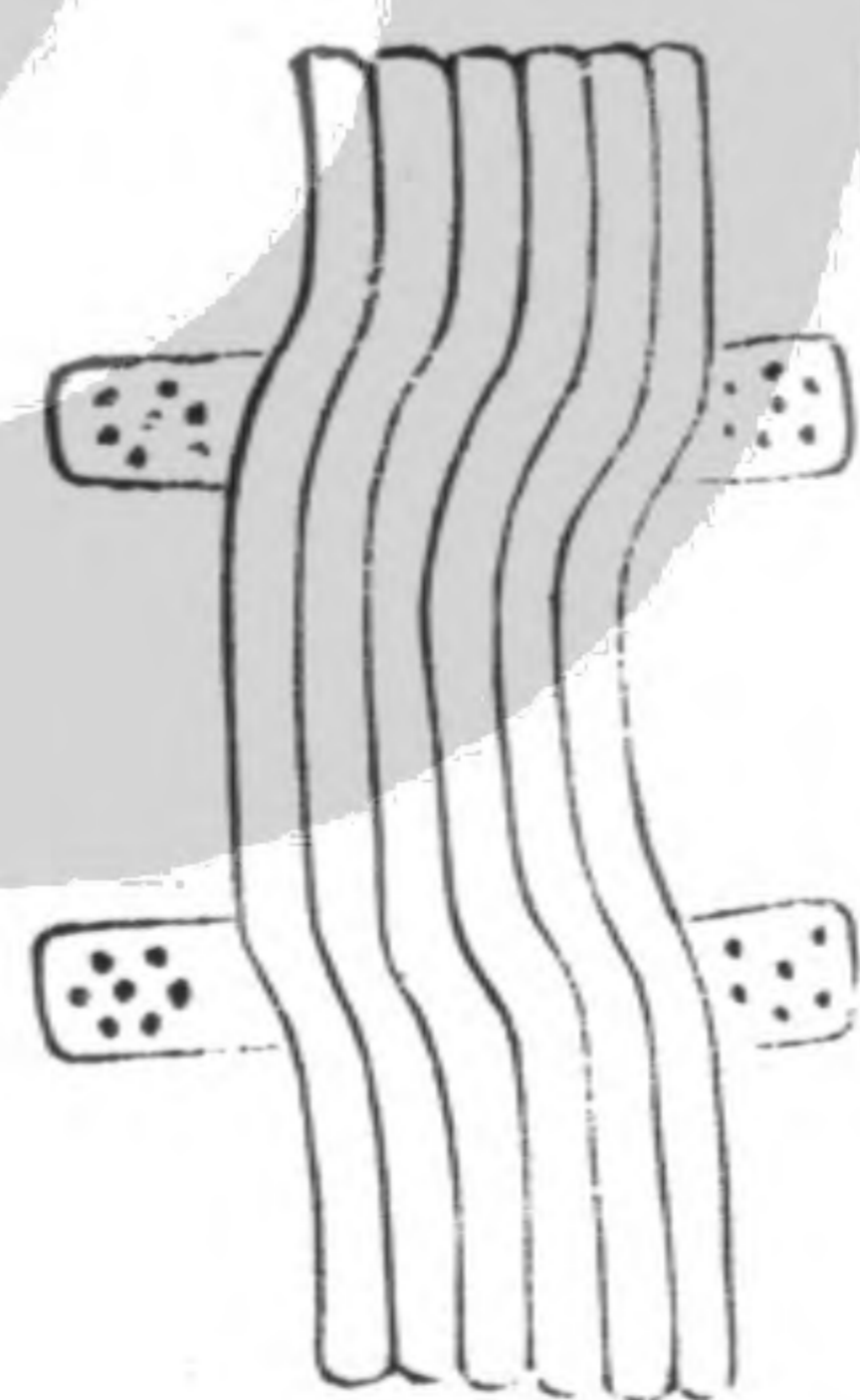

繅有五采
文所以薦
玉木為中
幹韋衣而
畫之

牙璋

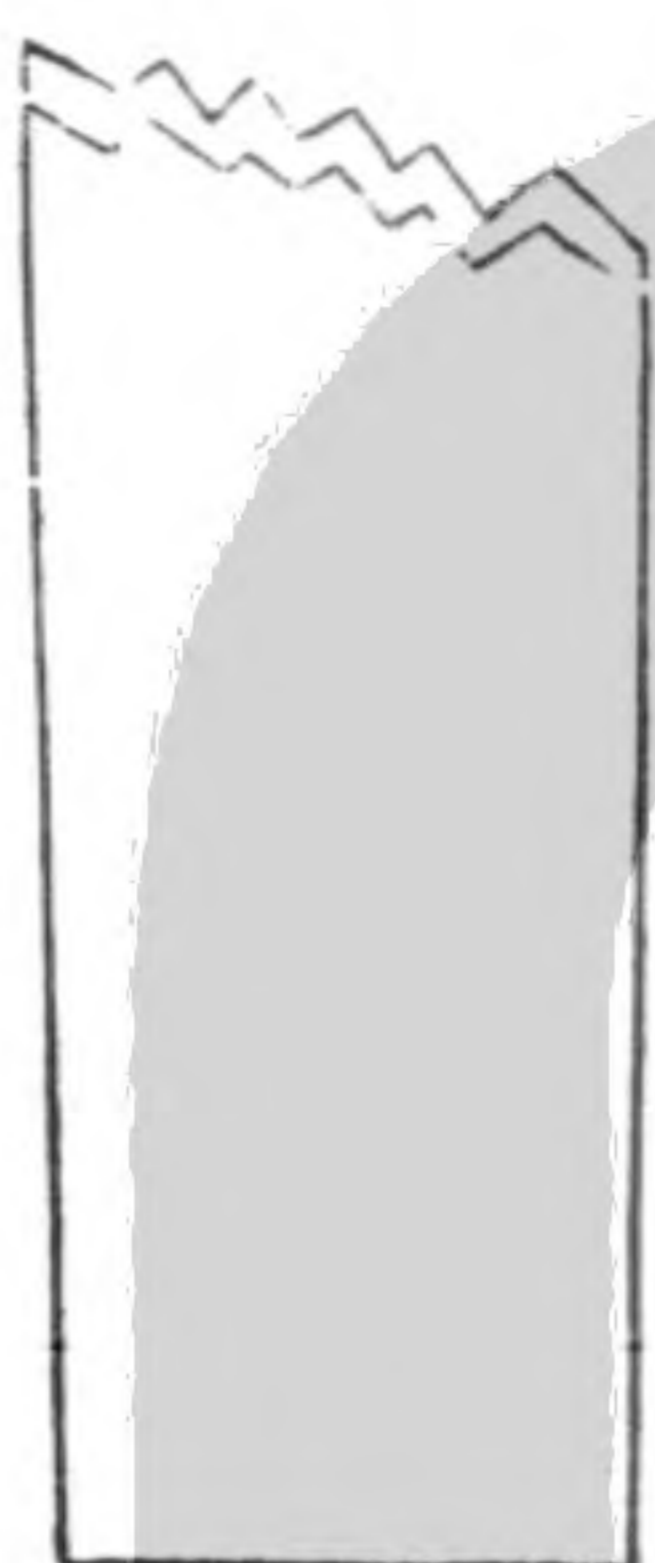

牙璋以起
軍旅以治
兵守瑒以
為牙

白琥 色白

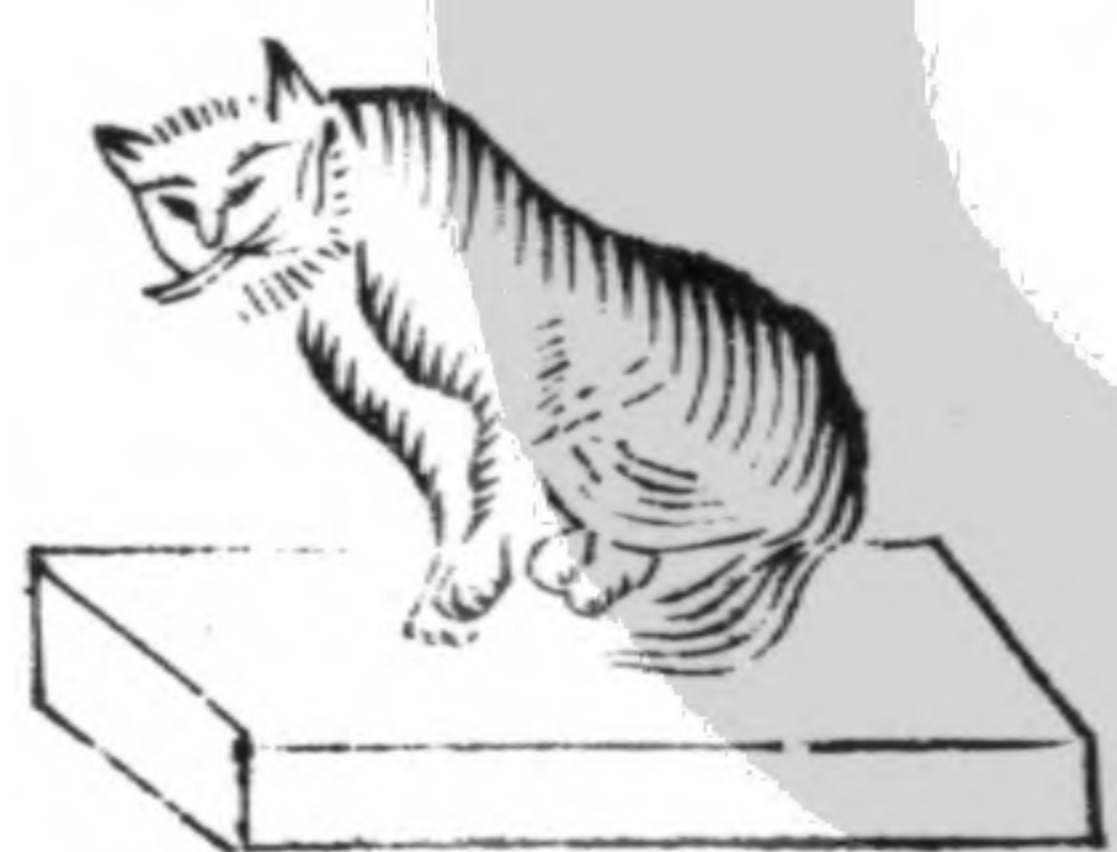

白琥禮西
方長九寸
廣五寸刻
伏虎形高
三寸

諸侯繅藉

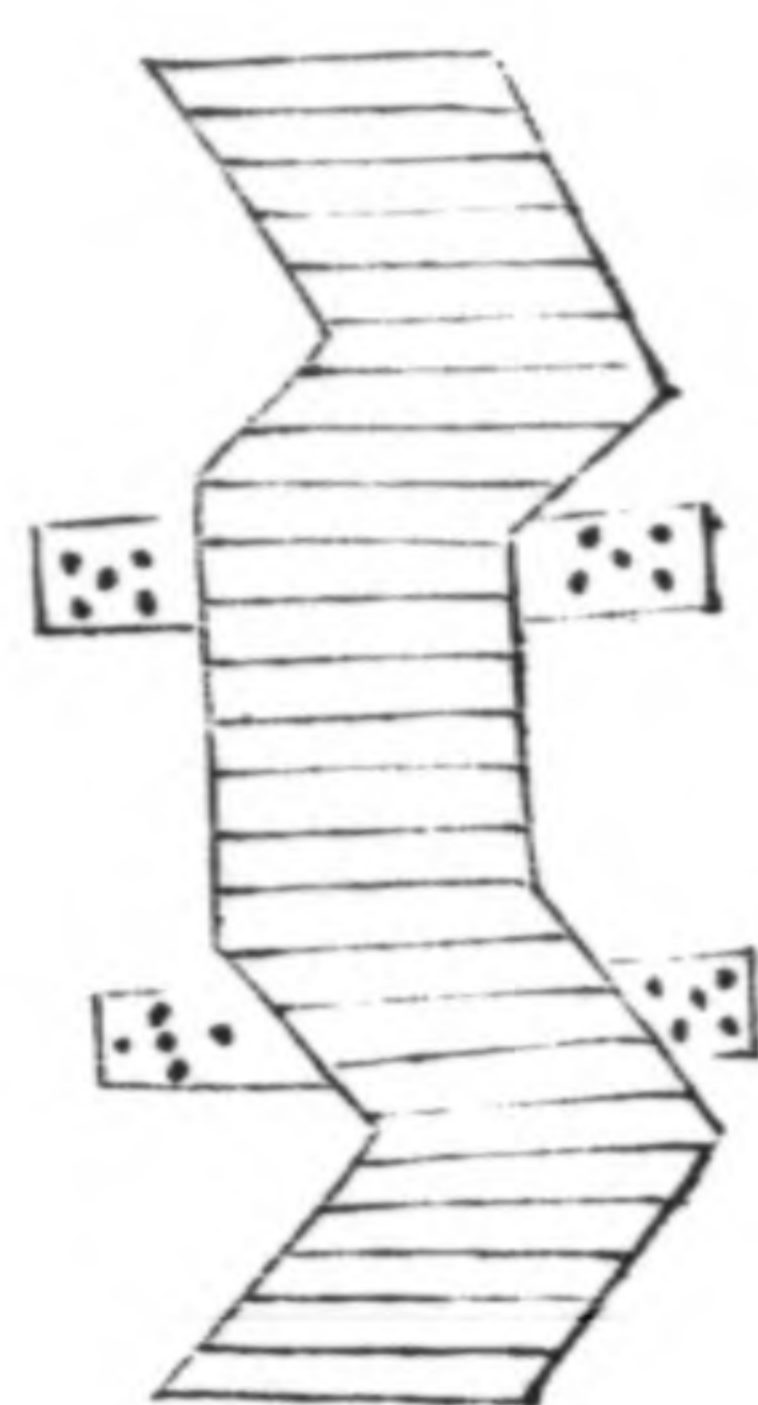

諸侯三采
三就三就
三匝也

穀圭

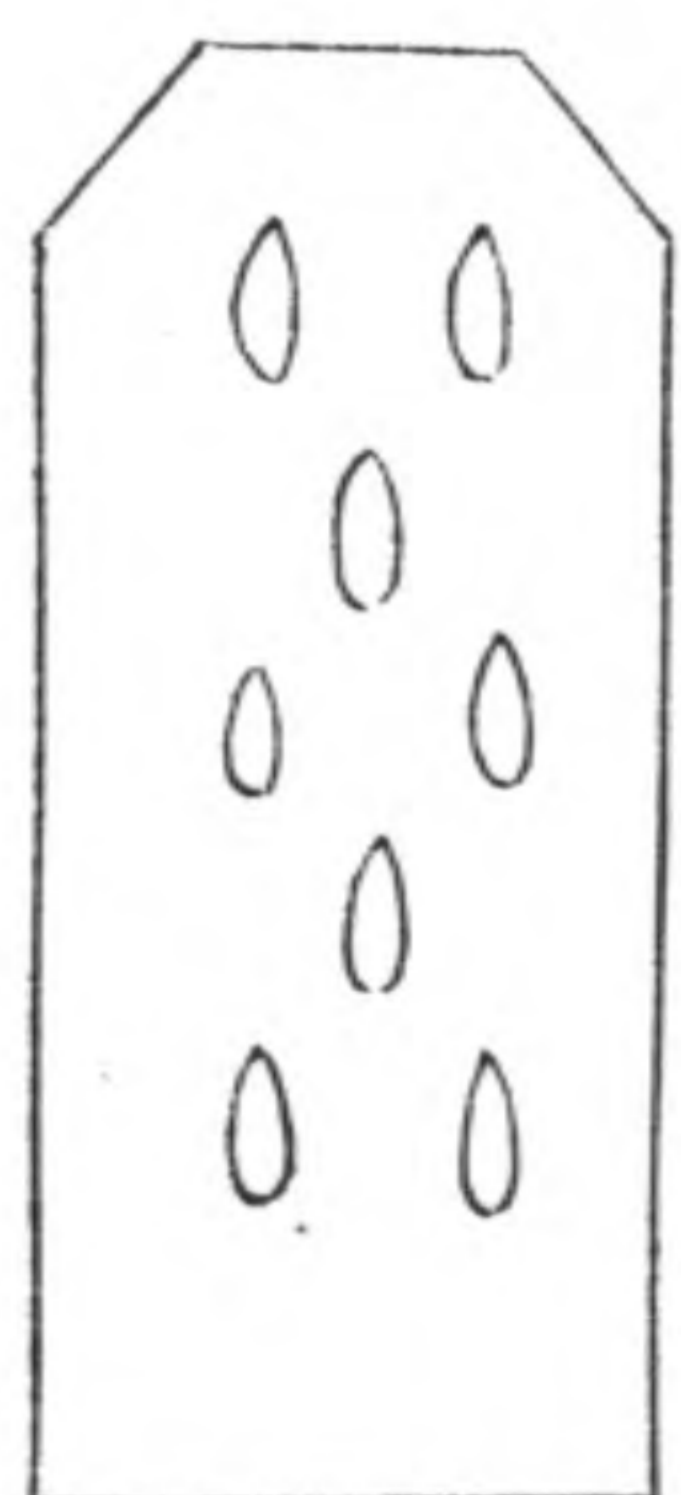

穀圭七寸
天子以聘
女其飾若
栗文

玄璜 色玄



玄璜禮北
方半璧曰
璜

蒲穀繅藉



子男朱綠
二采再就
藻水草之

大璋



大璋七寸
射四寸厚
寸諸侯以
聘女

四圭有邸 色赤

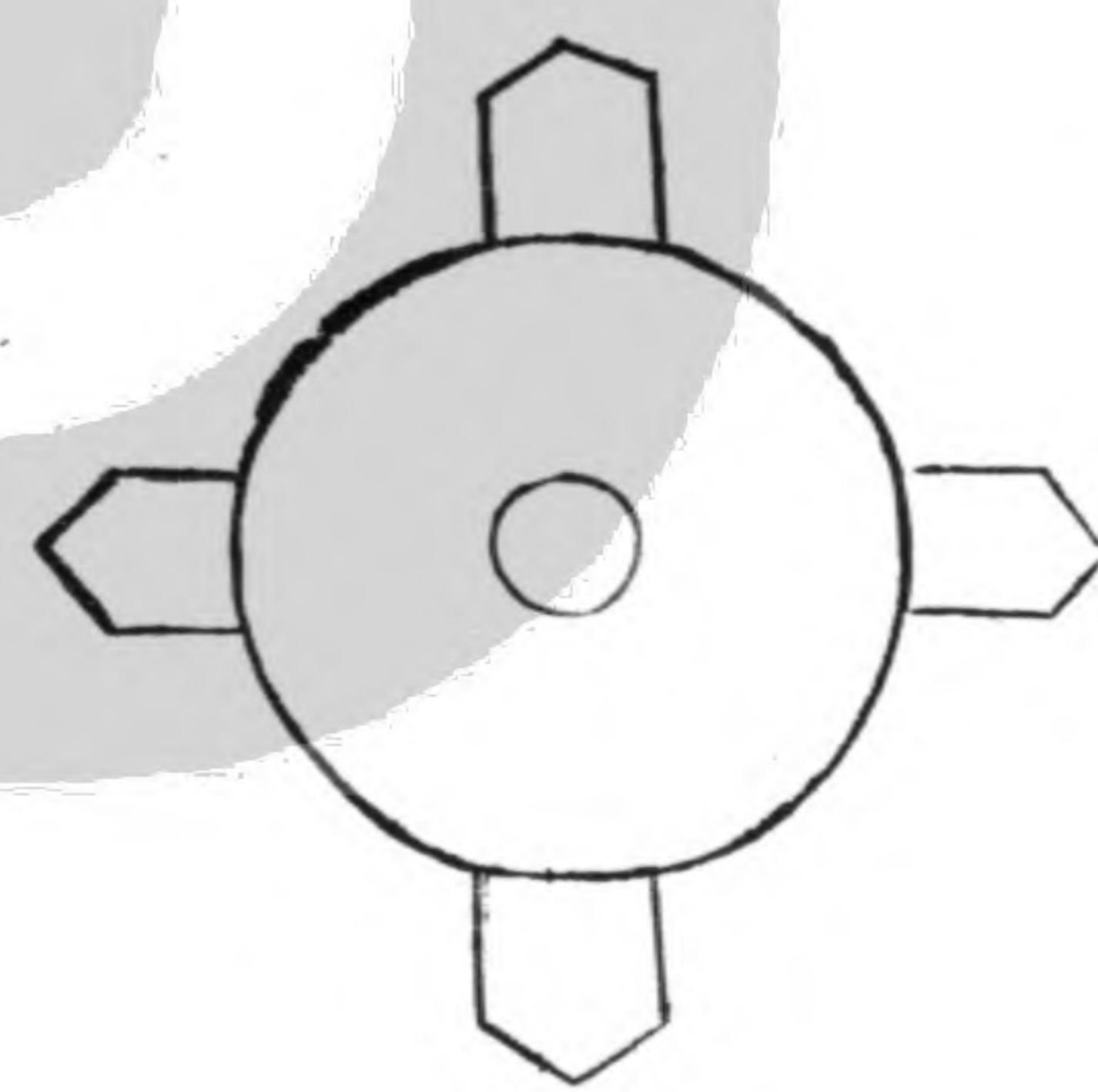

典瑞四圭
有邸以祀
天旅上帝
玉人四圭
尺有二寸

琢璧琮

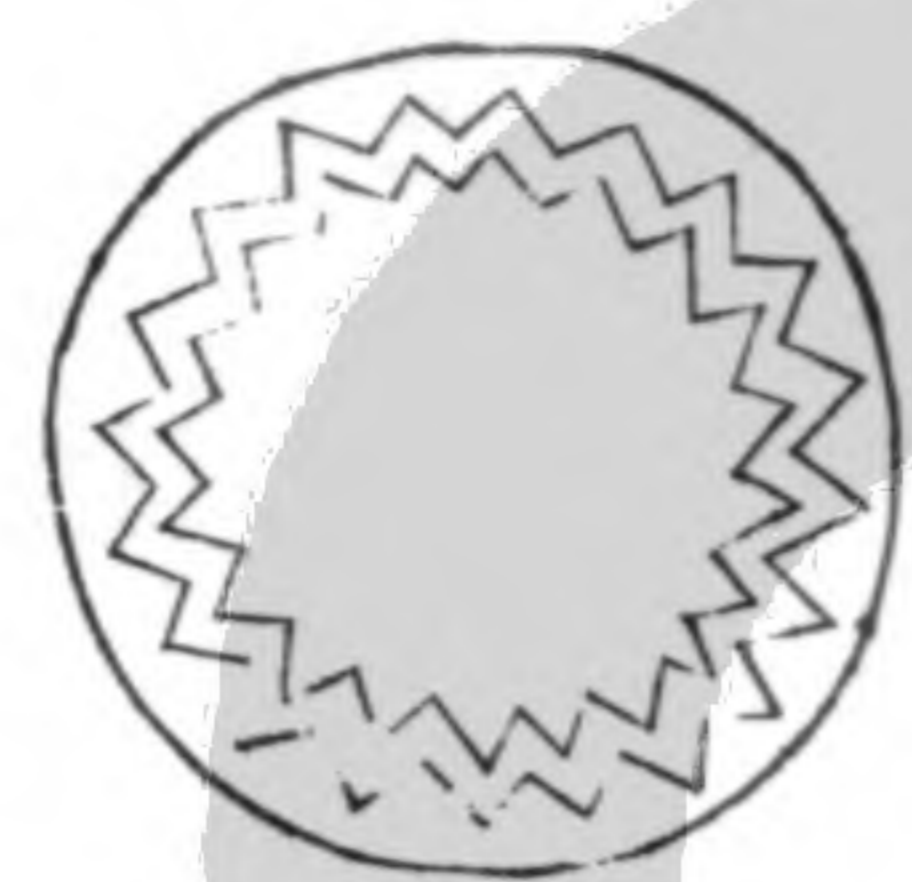

琢璧琮八
寸以頰聘

大璋瓚

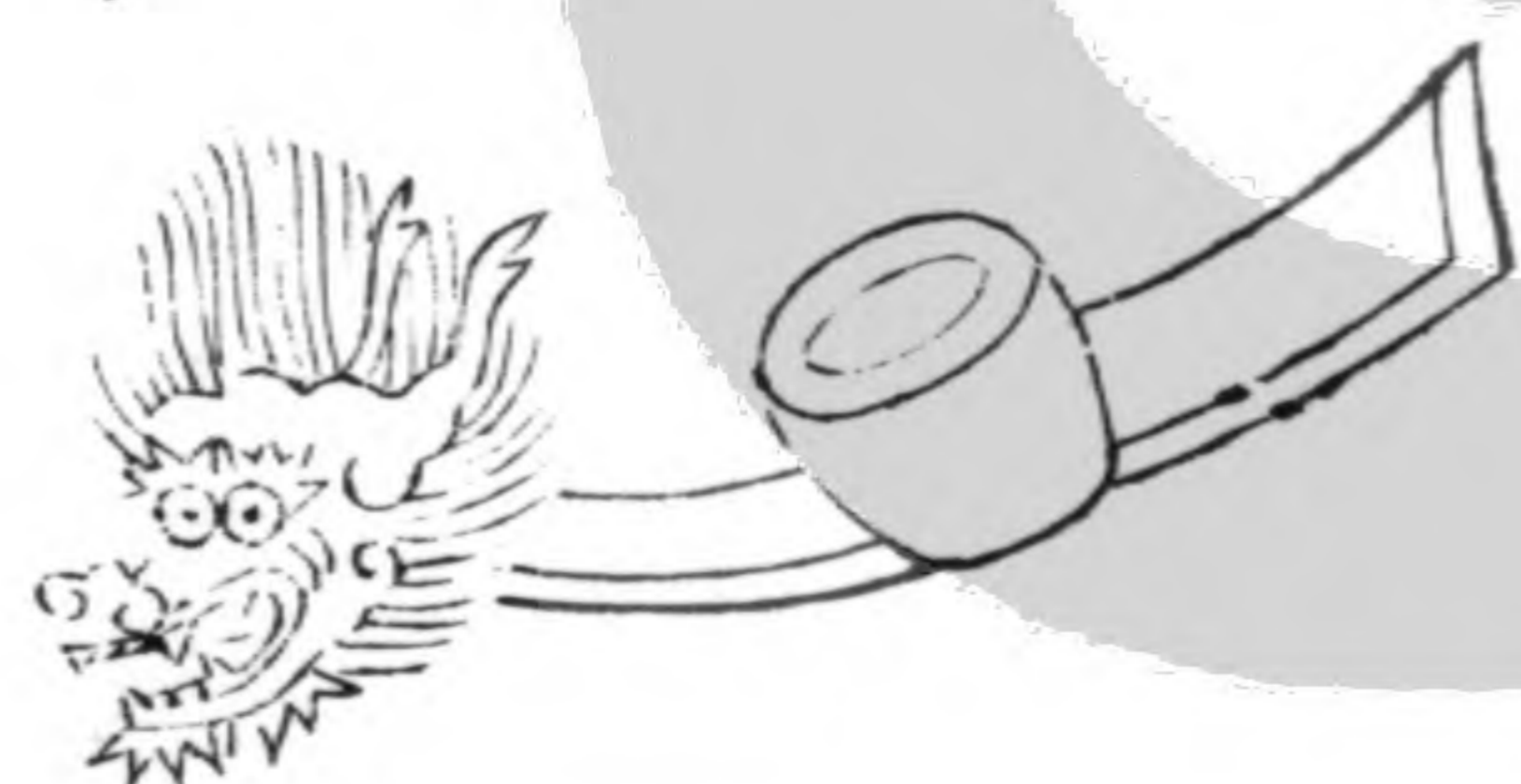

大璋九寸
射四寸厚
寸黃金勺
青金外朱
中鼻寸銜
四寸有繅
子巡守所
過大山川
用禮其神

方明木

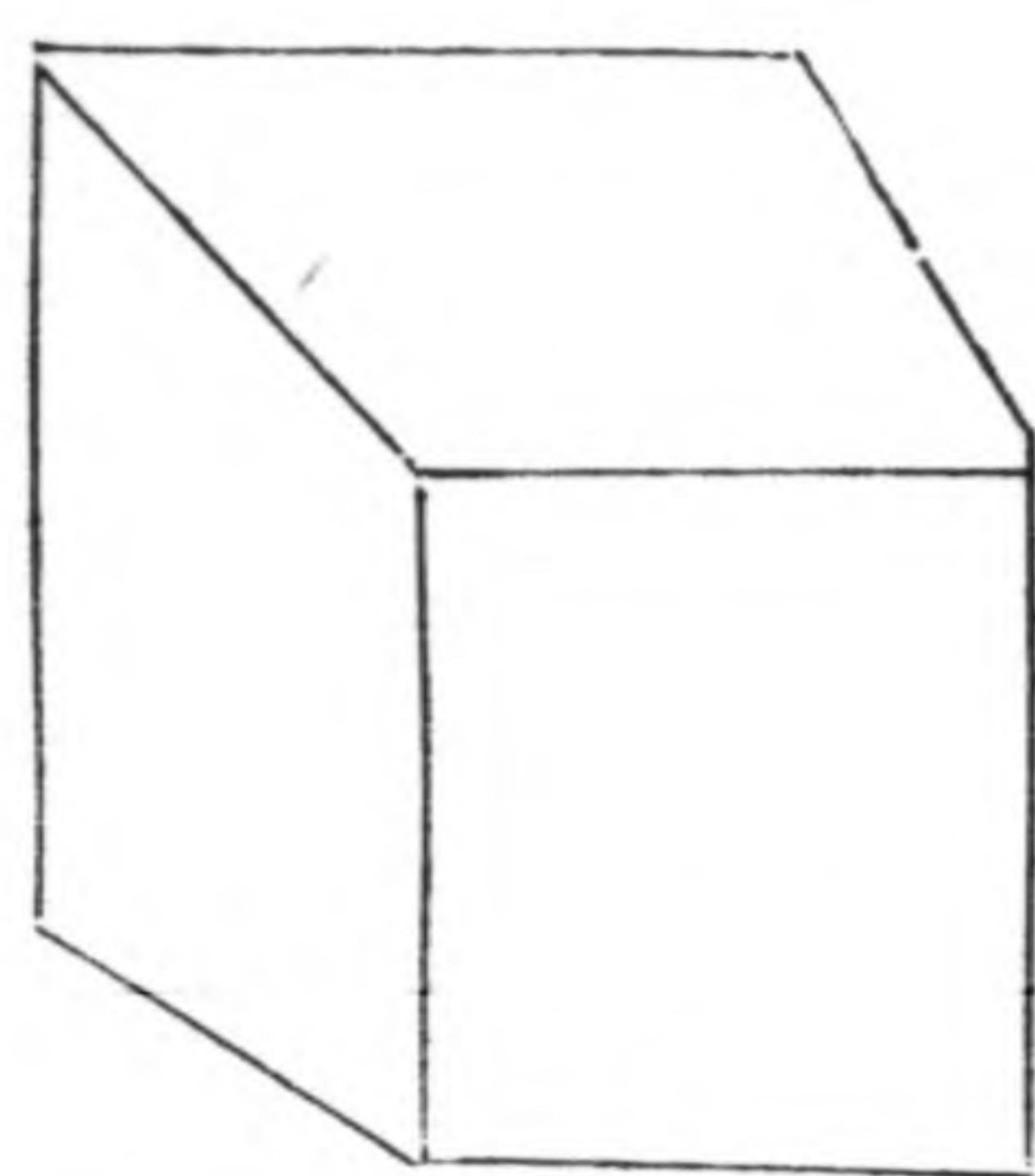

方明木也
方四尺設
六色以著
六玉也

方明壇

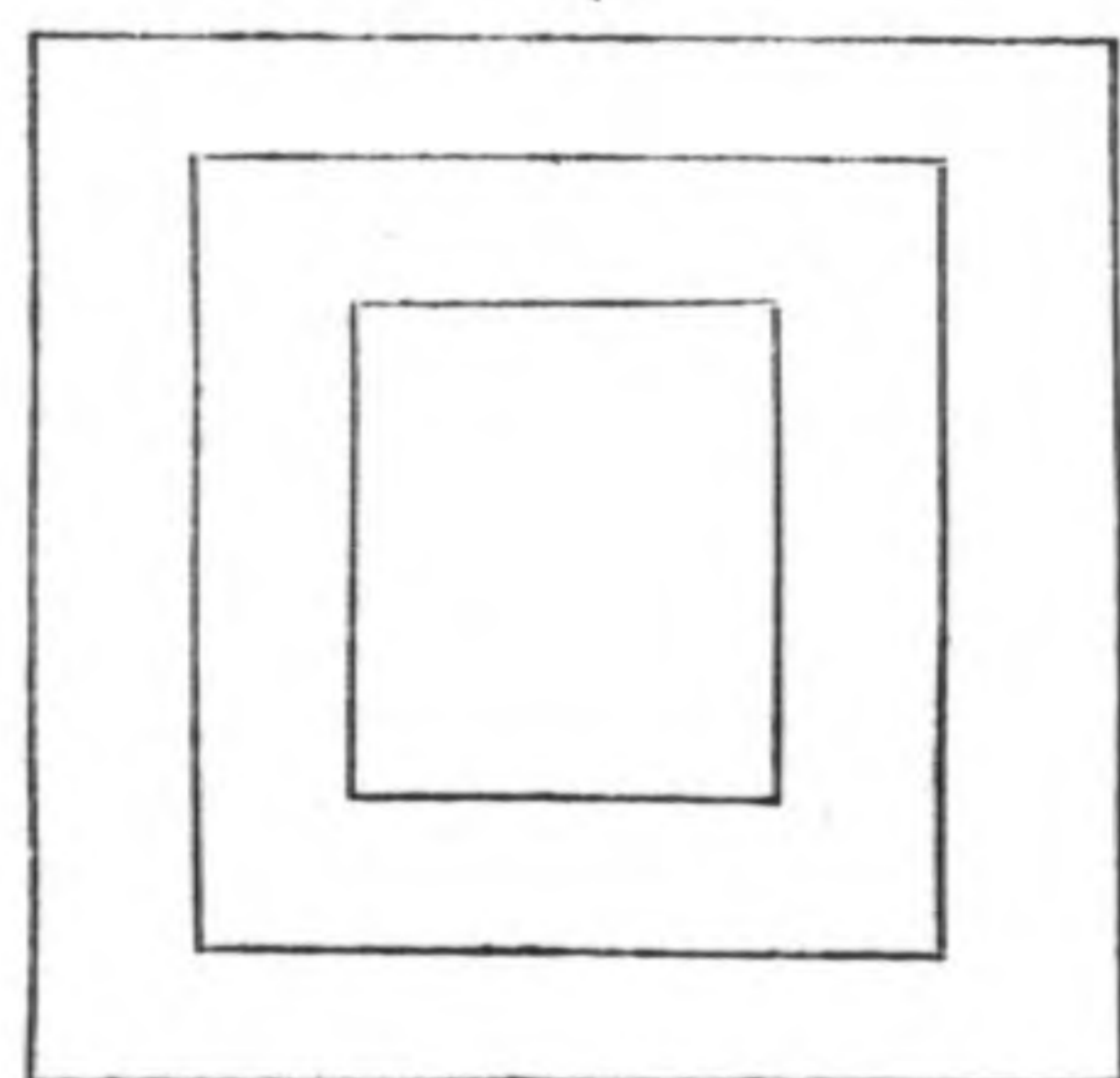

諸侯親於
天子為宮
三百步四
門壇十有
二尋深四
尺加方明
於其上

大圭天子之笏也王晉大圭以朝日執冒圭以朝諸侯至於鎮圭則所用廣矣鎮圭一曰珍圭以徵守以恤凶荒徵召守國諸侯凶荒則民有遠志不安其土故鎮安之 駟讀為組秤錘曰權以琮為權琮有臯以貫組為權也宗后王后也大琮有八角射角也后守大琮與天子守鎮圭同故曰內鎮兩圭四圭有邸邸本也中央為璧圭著其兩頭四面於璧也 日月星辰麗於天者皆陽類故祀以圭璧山川麗於地皆陰類故祀以璋邸射璋邸必

象射之貫以山川通氣故也造贈賓客者山川為國阻固賓客為國捍蔽故也 雙植謂之桓公二王之後及王之上公也信圭之信當作身信圭躬圭皆象人形欲其慎行以保身也穀所以養人蒲為席所以安人 蒼璧禮天謂天皇大帝在北極者也璧中有孔曰好週邊曰肉好倍肉曰瑗肉倍好曰璧黃琮禮地謂神在崑崙者也東方蒼精之帝南方赤精之帝西方白精之帝北方黑精之帝禮神者必象其類璧圓象天琮八方象地圭銳象

春物初生半圭曰璋象夏物半死虎猛象秋嚴半
璧曰璜季冬閉藏地上無物惟天半見 璧羨者
璧體圓本徑九寸今言羨則旁減一寸以益上下
則上下長一尺也 琬圭無鋒芒故以治德結好
琰圭有鋒芒有征伐誅討之象 圭瓚圭首為器
可以挹鬯裸祭謂之瓚 天子巡守祀大山川用
大璋次山川用中璋小山川用邊璋 齒牙兵象
故以之發兵若後之銅虎符發兵也 男女之合
取其不失性而生生不窮之意故用穀圭 纁藉

纁讀藻五就五匝也一匝為一就 方明者木也
方四尺上下四旁各一尺設六色每方一色象天
地四方也設六玉每方以其玉函木上上與東皆
圭上為天帝東方帝所出其玉同圭銳象陽居上
璧孔象陰居下璋半圭象半陽居南璜半璧象半
陰居北琥虎形象金猛居西圭上剡象物生居東

匱人制圖

蜃



山川四方
用蜃漆尊
畫為蜃形
蚌曰含漿
尊之象也

大罍 有盖



祭祀社壇
用大罍即
瓦罍也取
質略之意

概



裸用概黑
漆為尊以
朱帶絡腹
形制容受
如蜃尊

瓢齋



崇門用瓢
齋崇祭名
門國門取
甘匏割去
祇以為尊

散



漆尊無飾
曰散醕事
用散醕磔
牲體者形
制如概尊

修

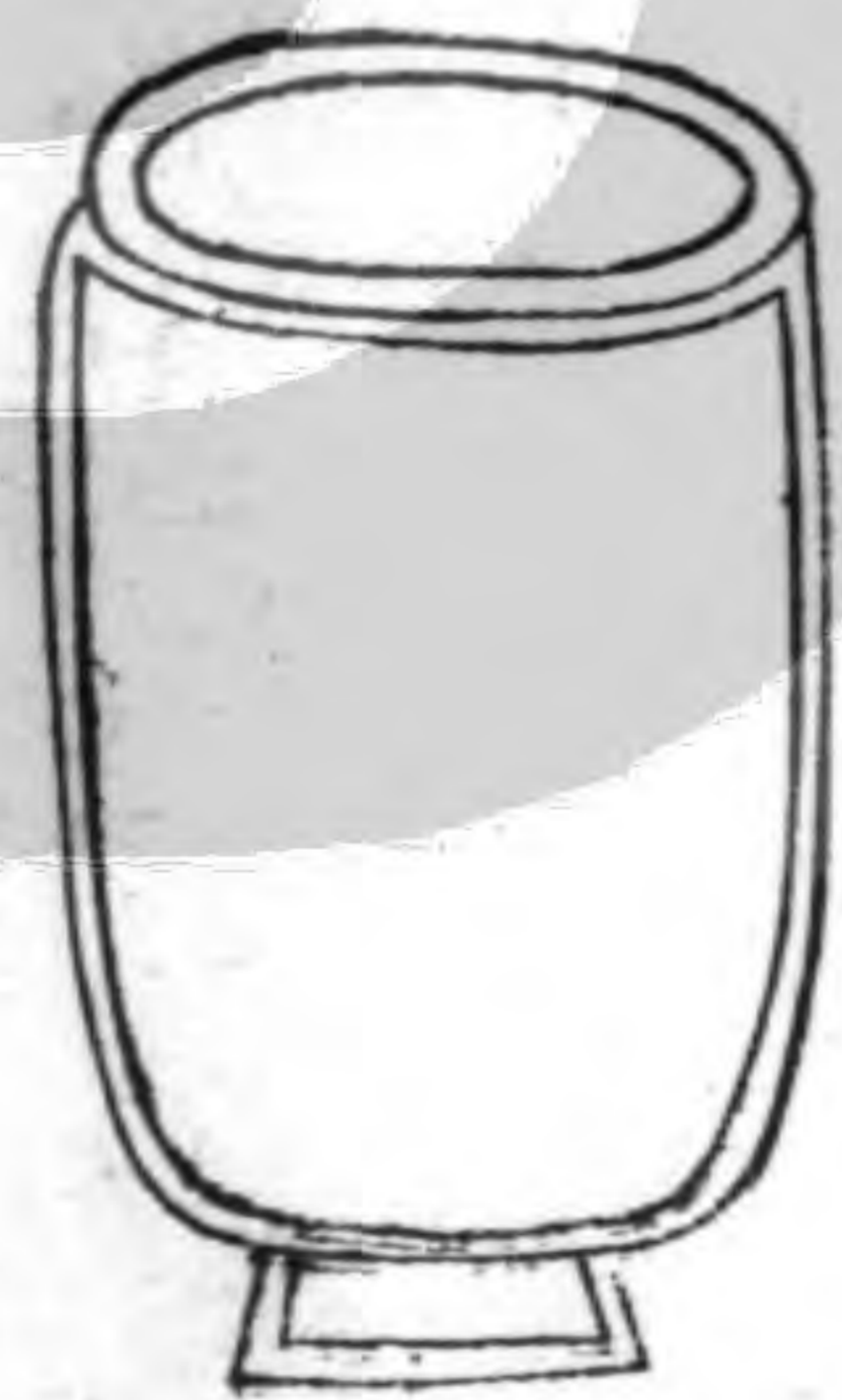

廟用修讀
曰卣卣中
尊謂獻象
之屬

圜丘樂圖

大司樂以圜鐘為宮黃鐘為角太簇為徵姑洗為羽冬日至於地上圜丘奏之樂六變則天神皆降可得而禮矣 天宮夾鐘與無射合無射上生仲呂與地林鐘同位林鐘與蕤賓合但仲呂林鐘同

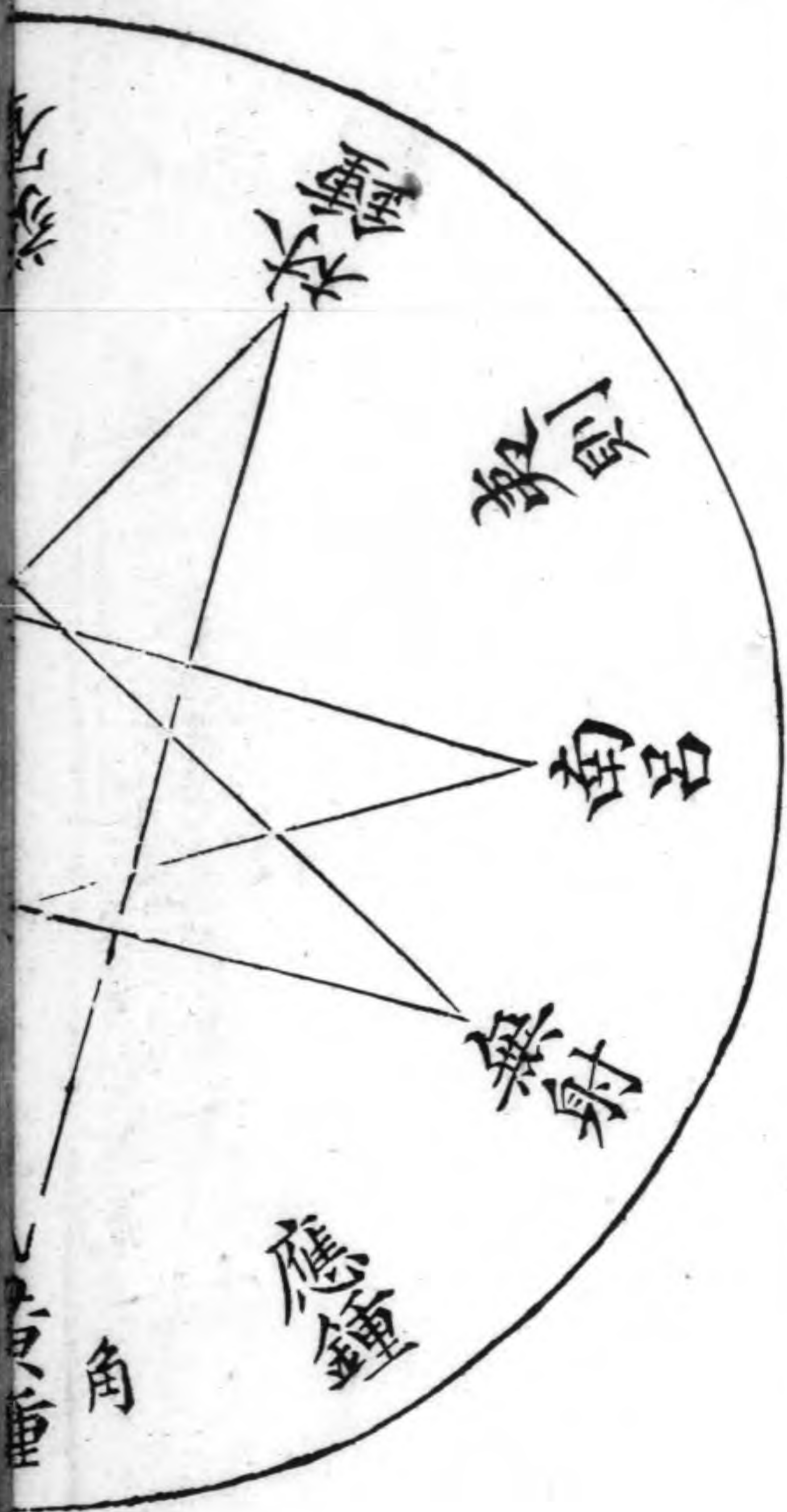

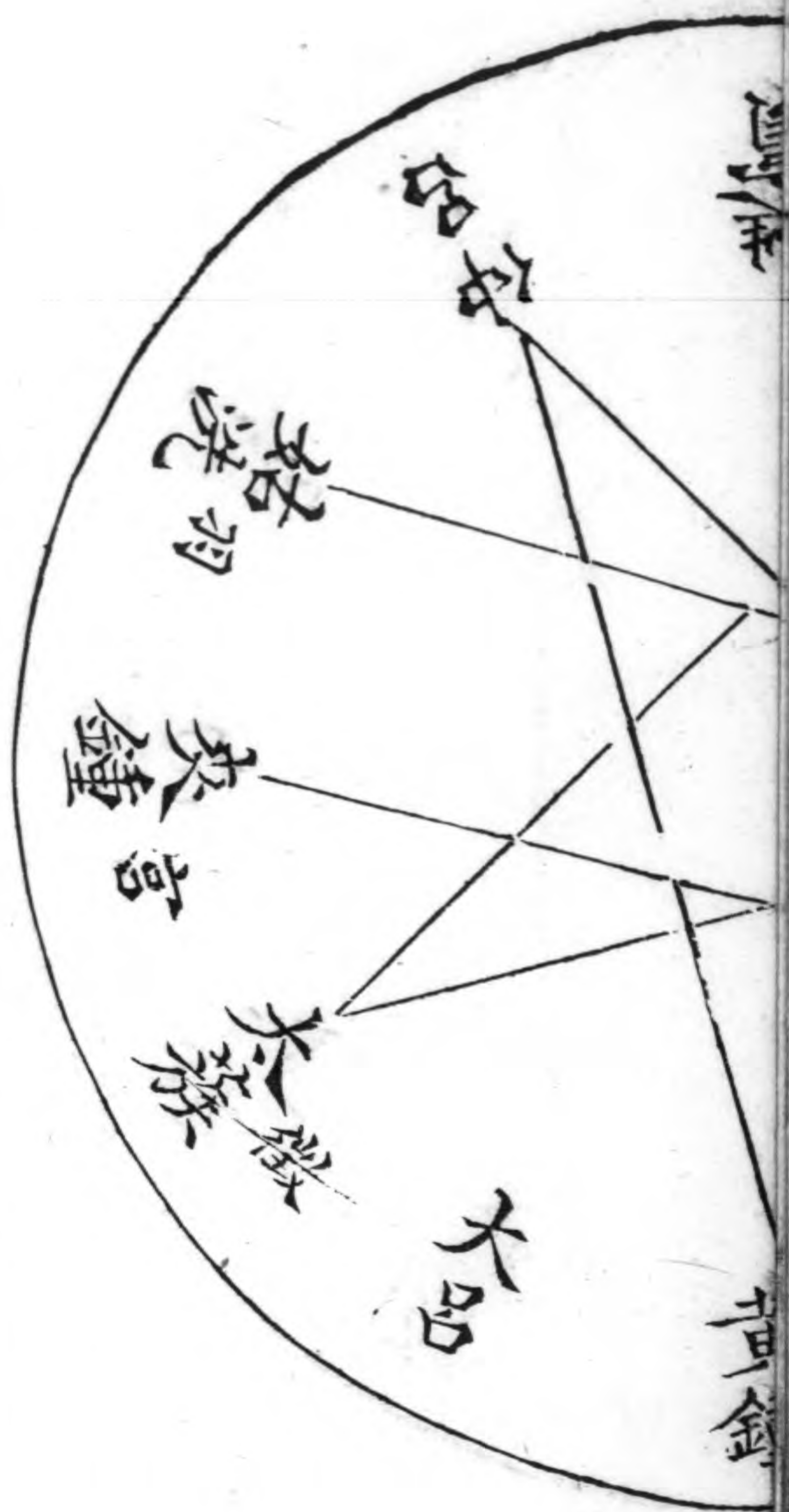

在南故同位然天尊地卑嫌其同位而不用也仲
 呂上生黃鍾為角黃鍾下生林鍾林鍾地宮又不
 用亦以嫌而不用林鍾上生太簇太簇為徵太簇
 下生南呂與無射同位又不用南呂上生姑洗姑
 洗為羽祭天四聲足矣

周禮四一

方丘樂圖

大司樂函鍾為宮太簇為角姑洗為徵南呂為羽
 夏日至於澤中方丘奏之樂八變則地示皆出可
 得而禮矣 地宮林鍾林鍾上生太簇太簇為角
 下生南呂南呂為羽是先生後用也南呂上生姑

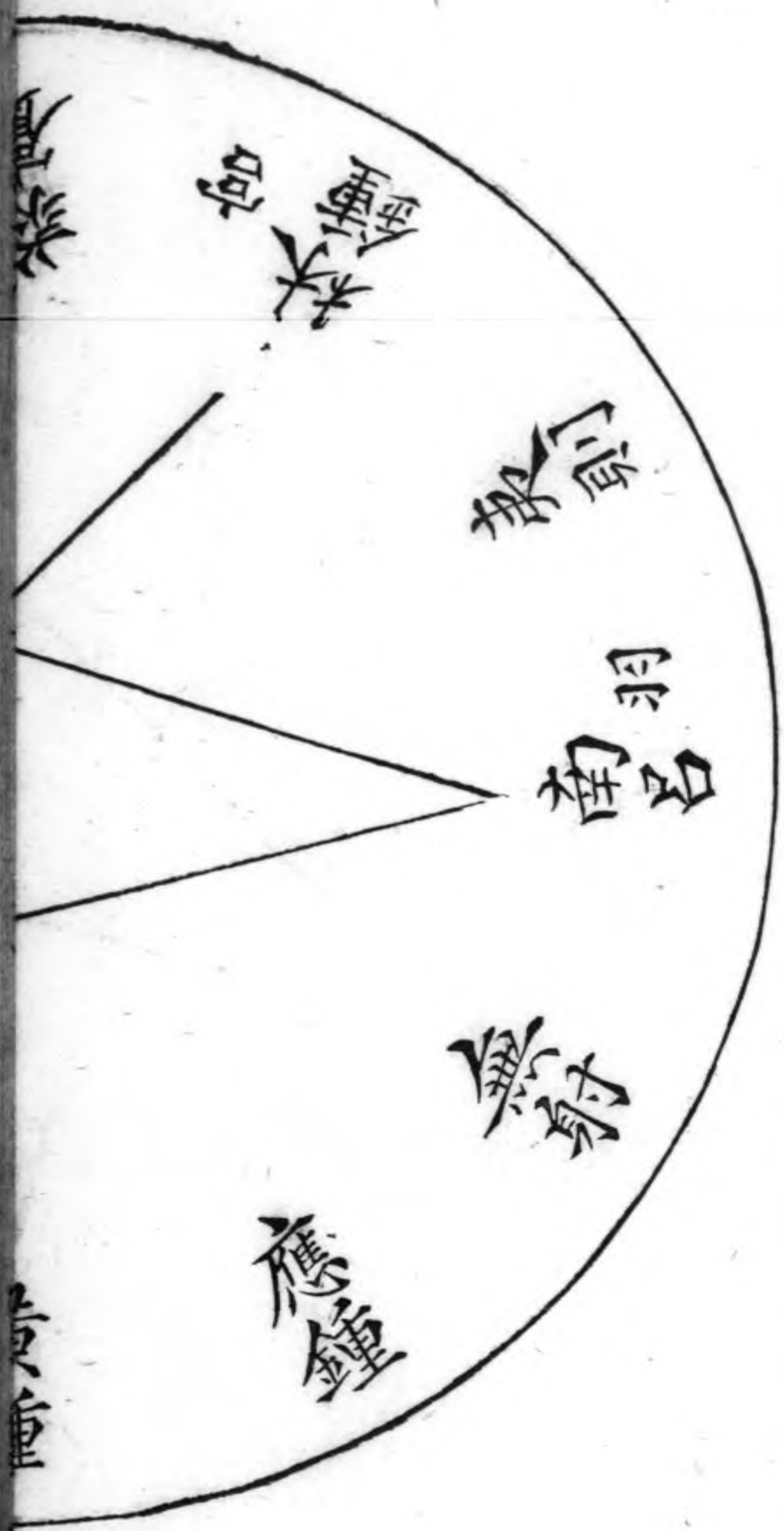

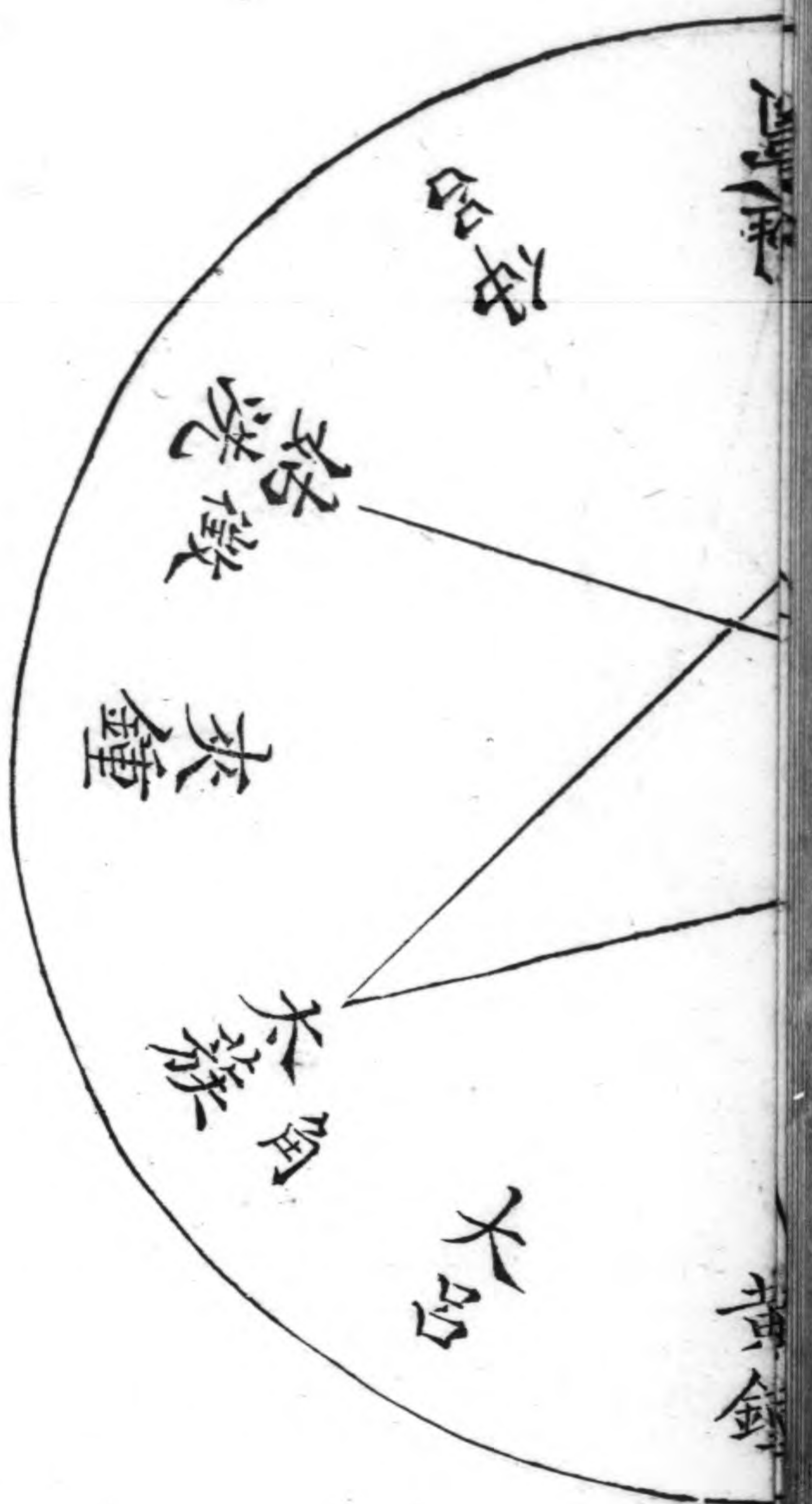

洗姑洗為徵後生先用也祭地四聲足矣

周禮四二

宗廟樂圖

人司樂以黃鍾為宮大呂為角大蕤為徵應鍾為羽宗廟之中奏之樂九變則人鬼可得而禮矣
 入宮黃鍾黃鍾下生林鍾林鍾為地宮又避之不取也林鍾上生大蕤大蕤為徵先生後用也大蕤

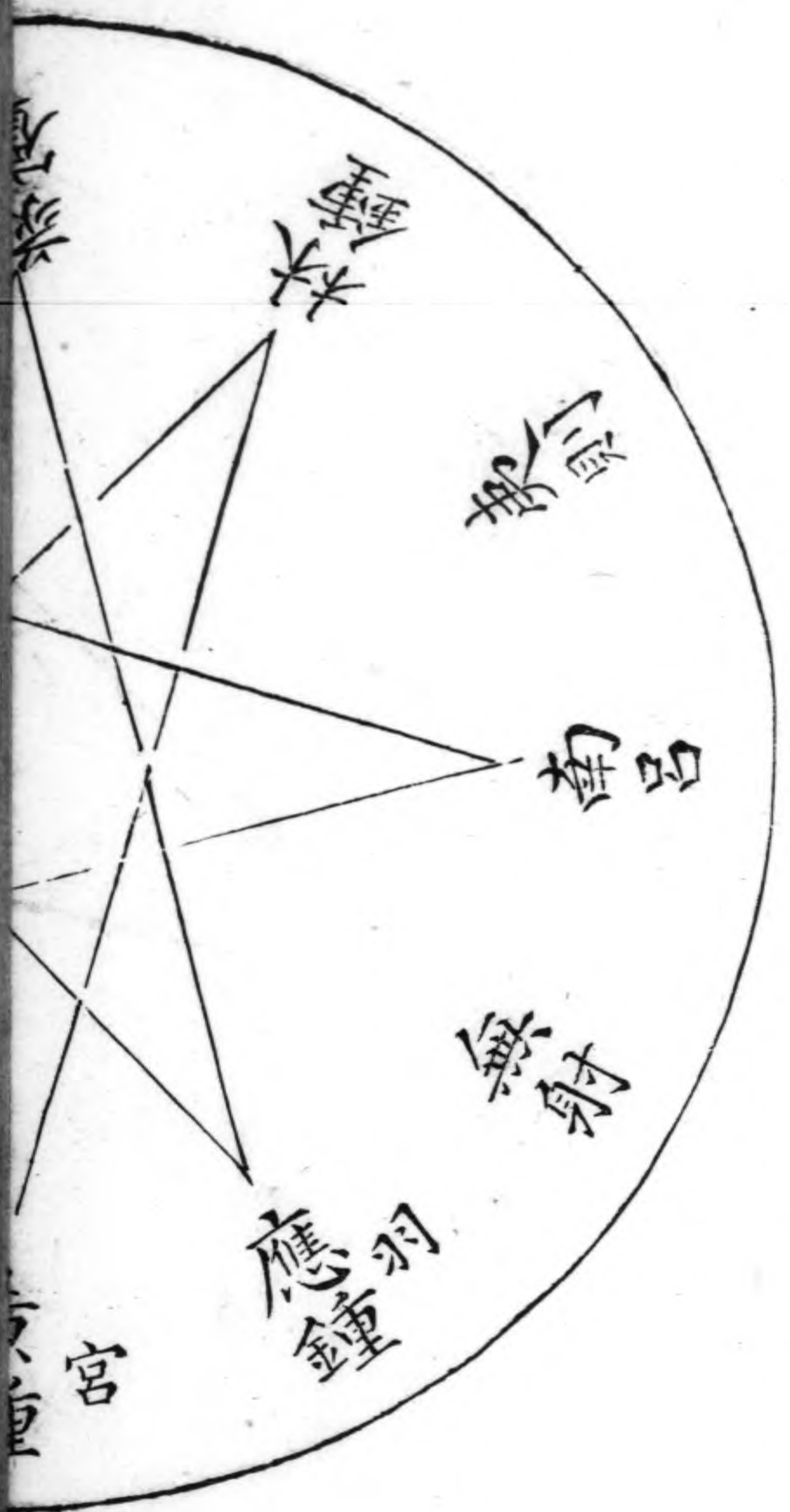

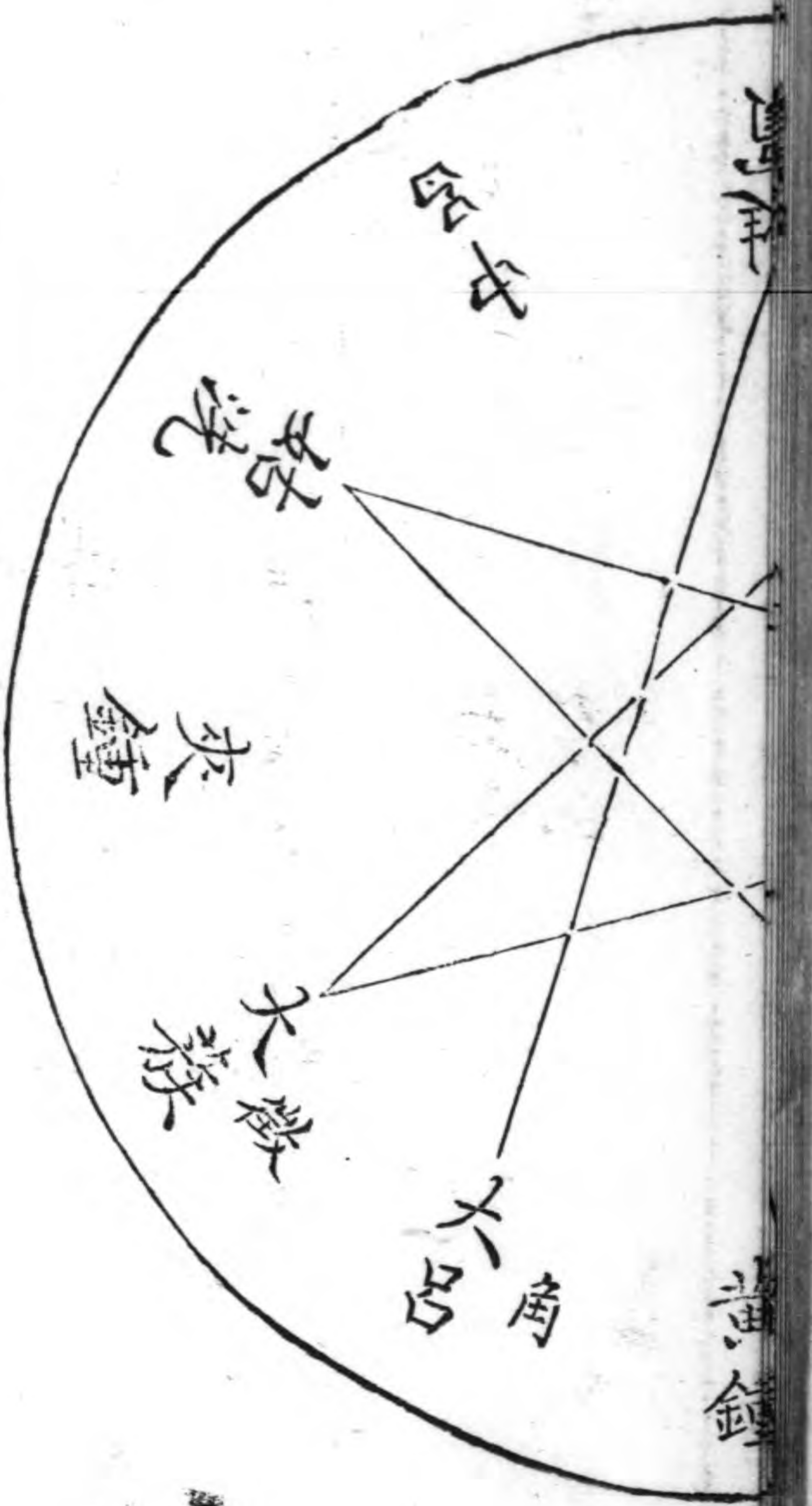

下生南呂南呂與天宮之陽同位又避之南呂上
 生姑洗姑洗南呂之合又避之姑洗下生應鍾應
 鍾為羽應鍾上生蕤賓蕤賓地宮之陽以林鍾是
 地宮與相配合故又避之蕤賓上生大呂大呂為
 角後生先用也

周禮四三

分舞樂圖

舞雲門

祀天神

歌大呂

舞咸池祭地示

奏太簇

舞大武享先祖

歌夾鍾

舞大磬祀四望

奏姑洗

舞大濩享先妣

歌小呂

舞大夏

祭山川

歌大呂

樂器制圖

大鐘

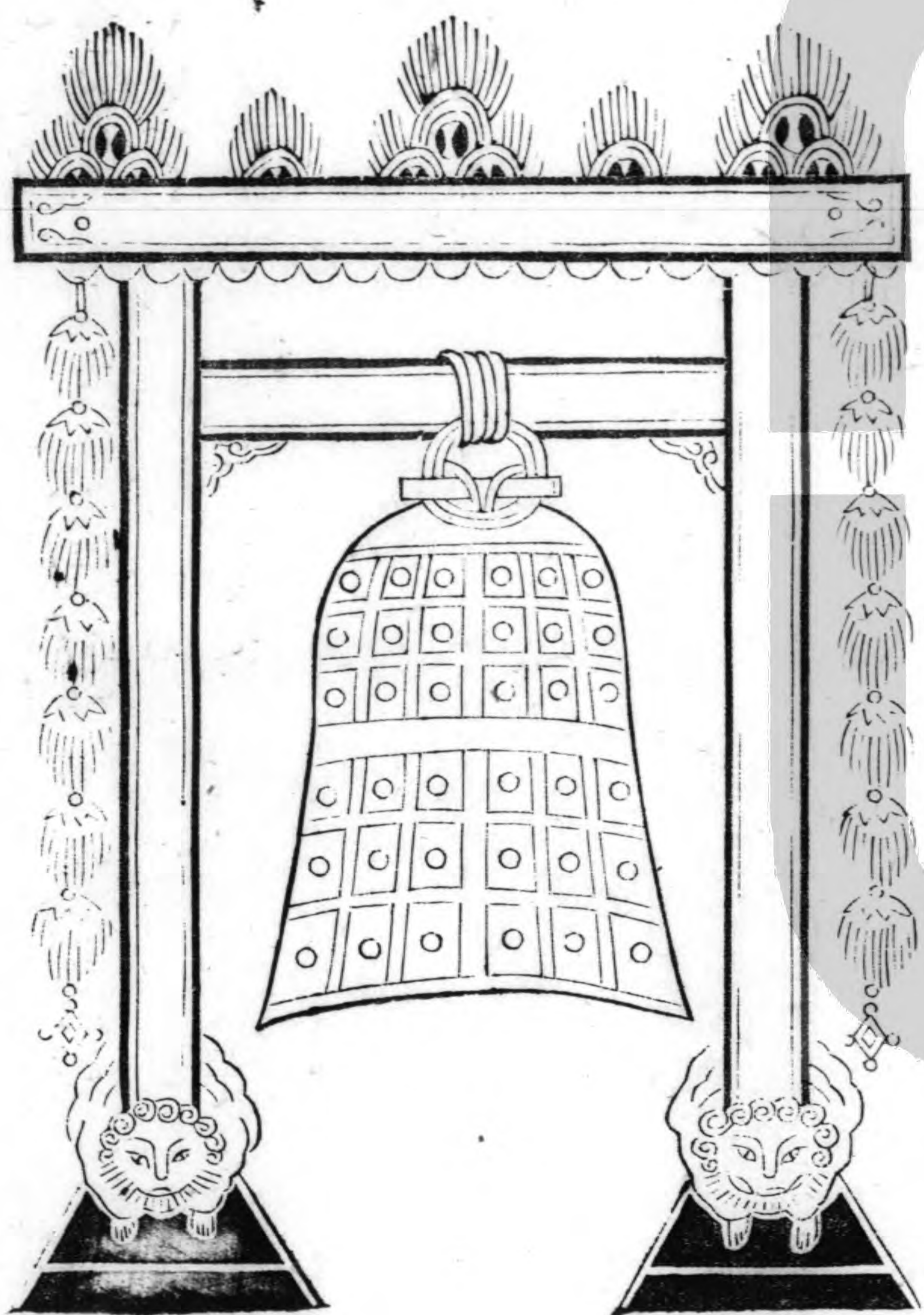

黃鐘陽聲之首大呂為之合太簇陽聲二應鍾合
姑洗陽聲三南呂合蕤賓陽聲四函鍾林一曰合夷
則陽聲五小呂中一曰合無射陽聲下夾鍾圈一曰合

大鐘特縣鐘也 典同凡為樂器以十有二律為
之數度單穆公曰先王之制鐘也大不出鈞重不
過石律度量衡於是乎生則樂器待律然後制而
律度又待鐘然後生故有十二辰之鐘以應十二
月之律十二辰之鐘大鐘也大鐘特縣詩書爾雅
所謂鏞是也非十二辰之鐘則編焉周禮所謂編
鐘是也

大磬

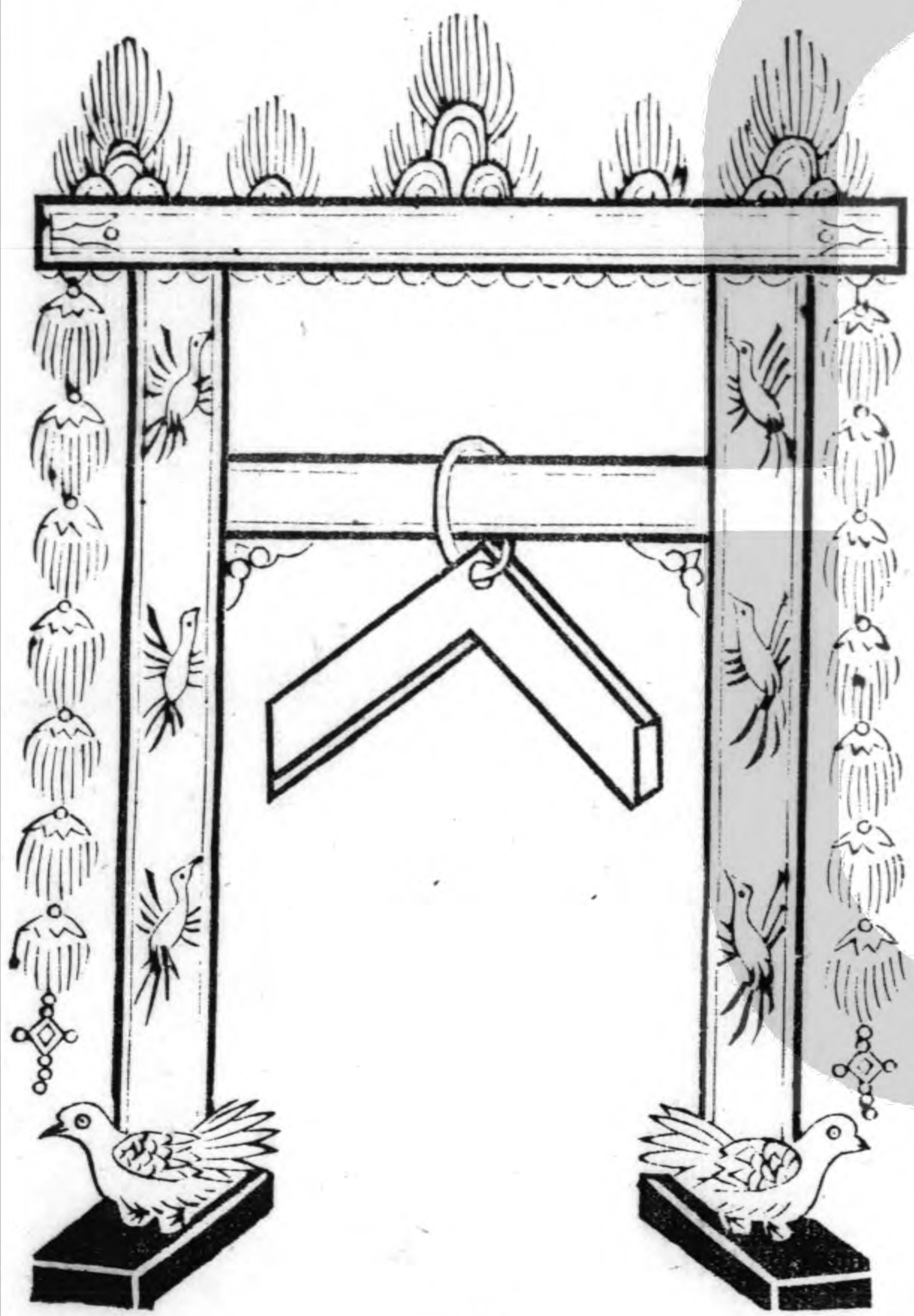

大磬特縣磬也 考工記磬氏為磬倨句一矩有
 半其博為一股為二鼓為三參分其股博去一以
 為鼓博參分其鼓博以其一為之厚 鄭司農云
 股磬之上大者鼓其下小者康成云股外面鼓內
 面小大長短雖殊其厚均也黃鍾之磬股鼓皆厚
 二寸餘推此可知

編鐘

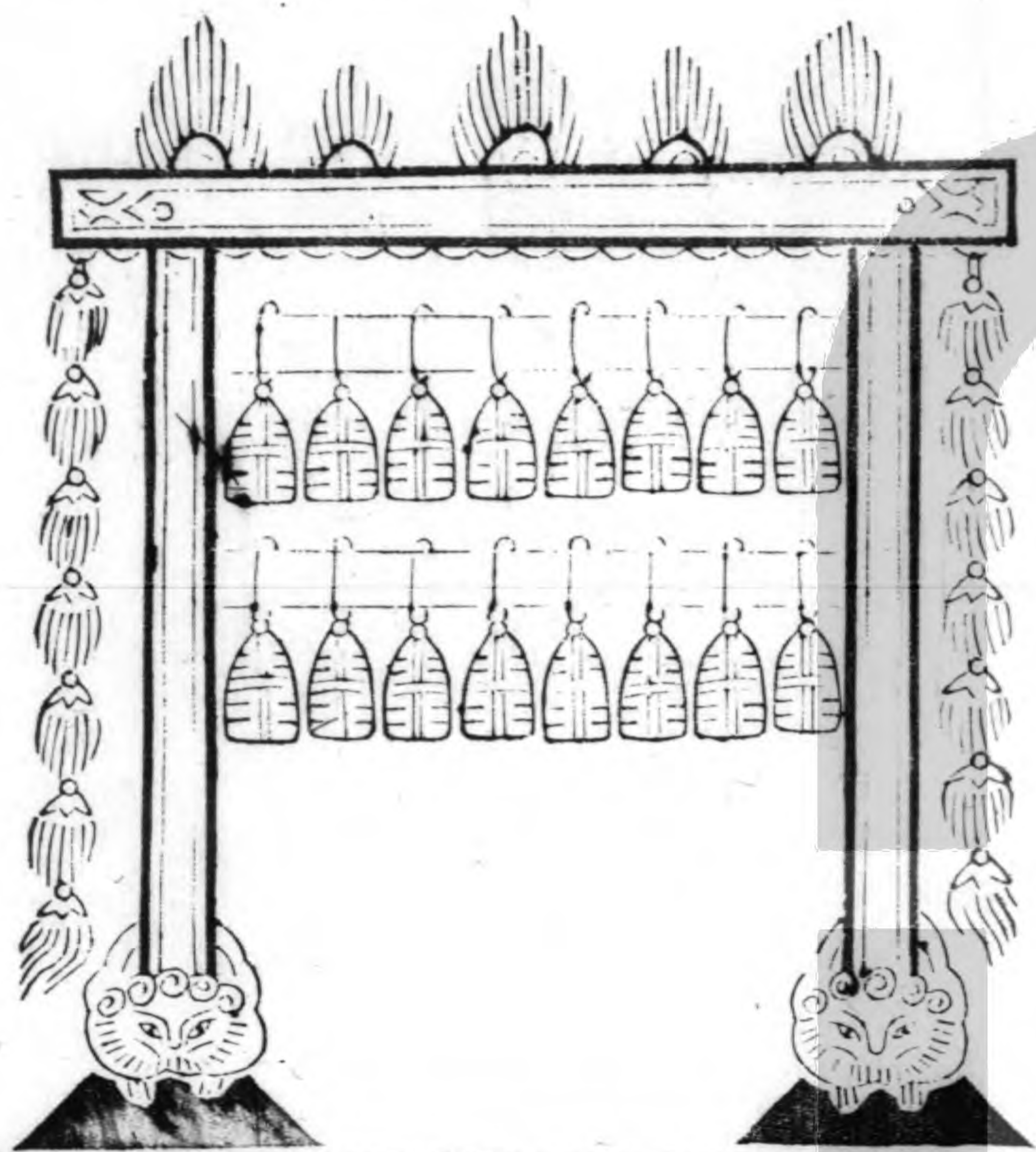

編磬

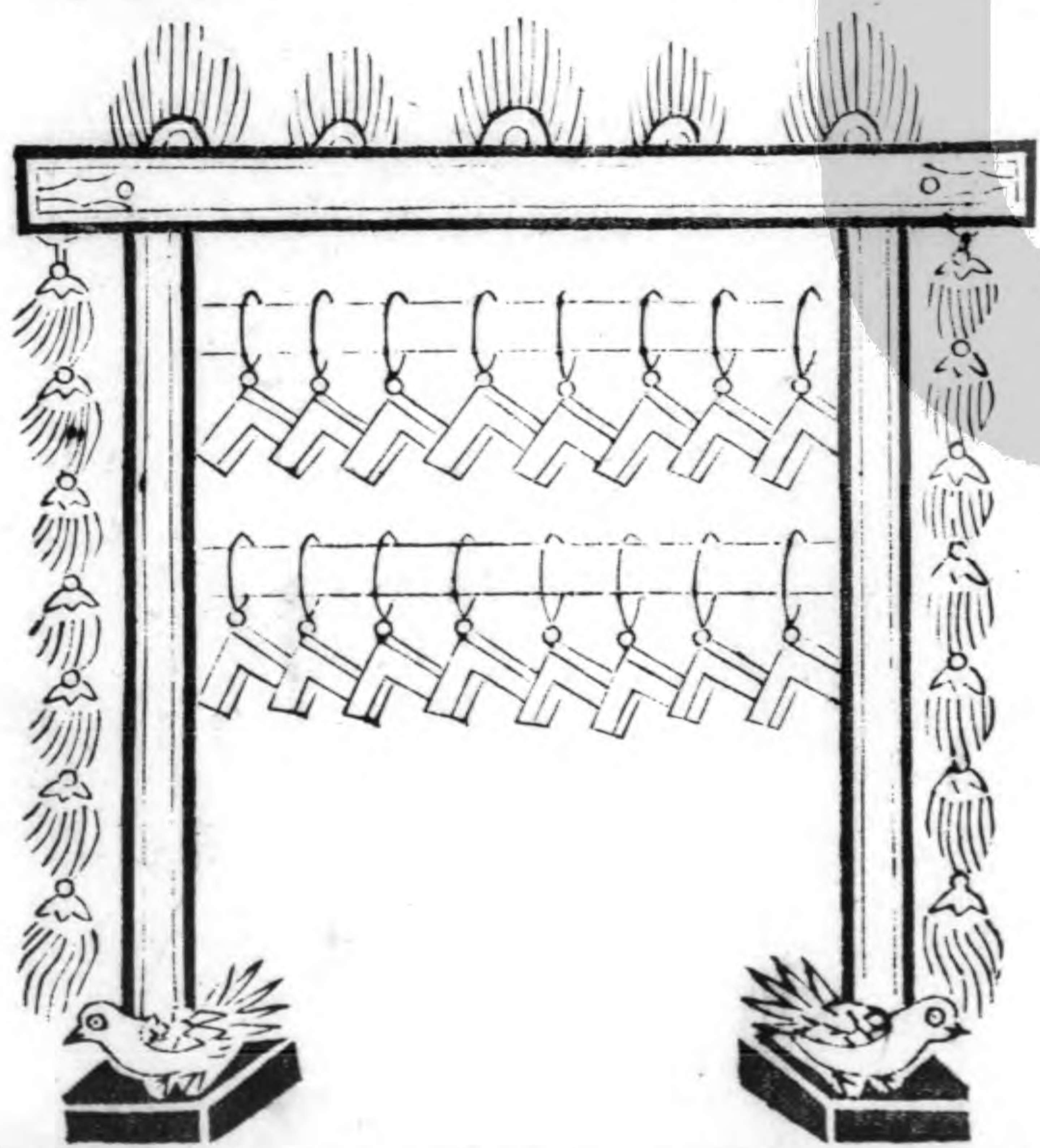

編鐘十六枚在一筍虞 鐘師掌金奏 編磬十
 六枚在一筍虞 眡瞭掌擊頌磬笙磬 磬在東
 方曰笙在西方曰頌 磬師掌教擊磬擊編鐘
 凡縣編鐘磬半為堵全為肆十六枚在一筍虞曰
 堵鐘一堵磬一堵曰肆

鑄

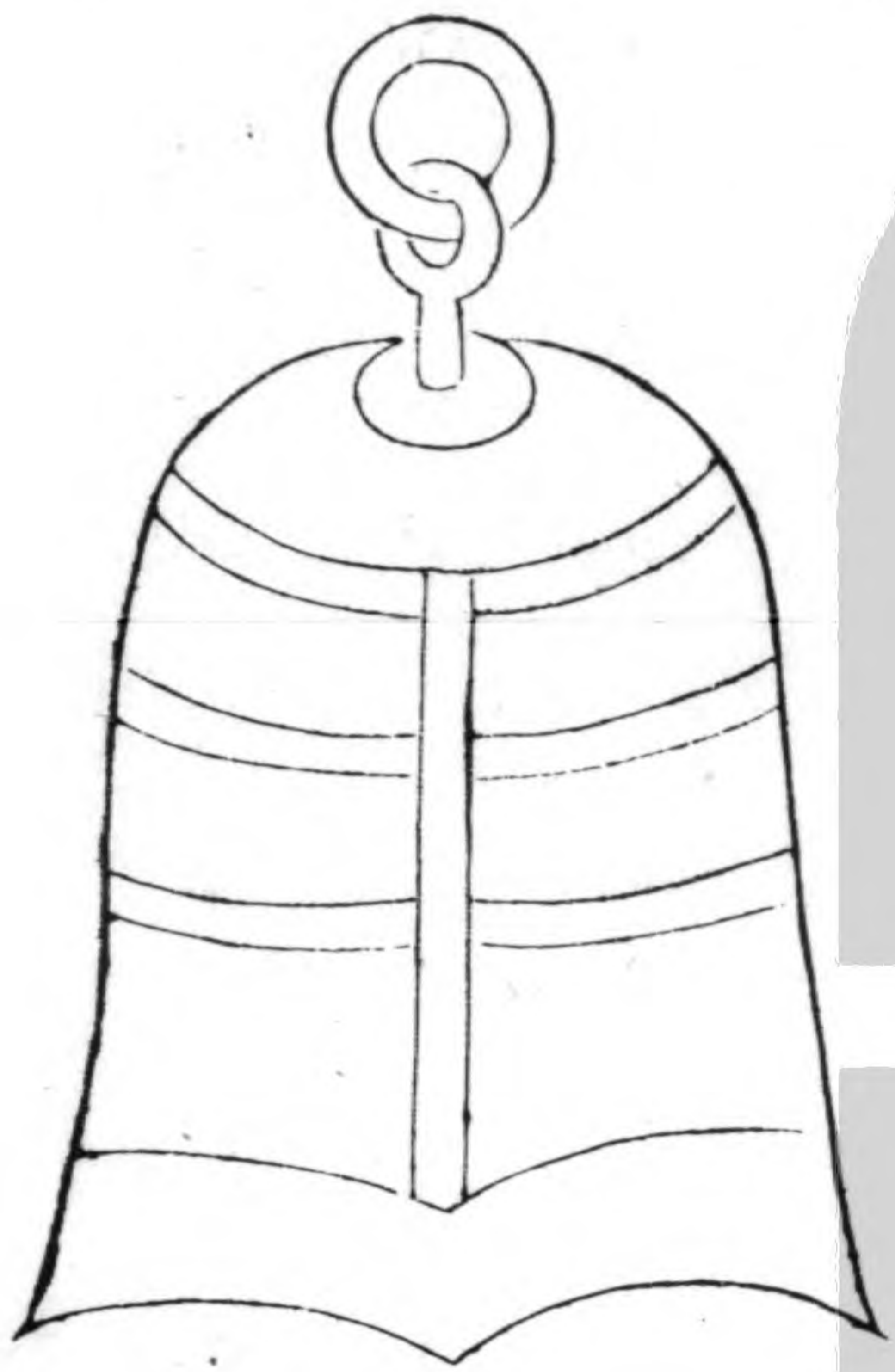

鑄師掌金奏之鼓祭祀
 鼓其金奏之樂國語伶
 州鳩曰細鈞有鐘無鑄
 大鈞有鑄無鐘細必和
 之以大大必和之以細
 鑄小鐘耳韋昭杜預皆
 以鑄為小鐘惟鄭康成
 曰鑄如鐘

竽

竽長四尺二寸三十二簧竹為之形參差如鳥翼

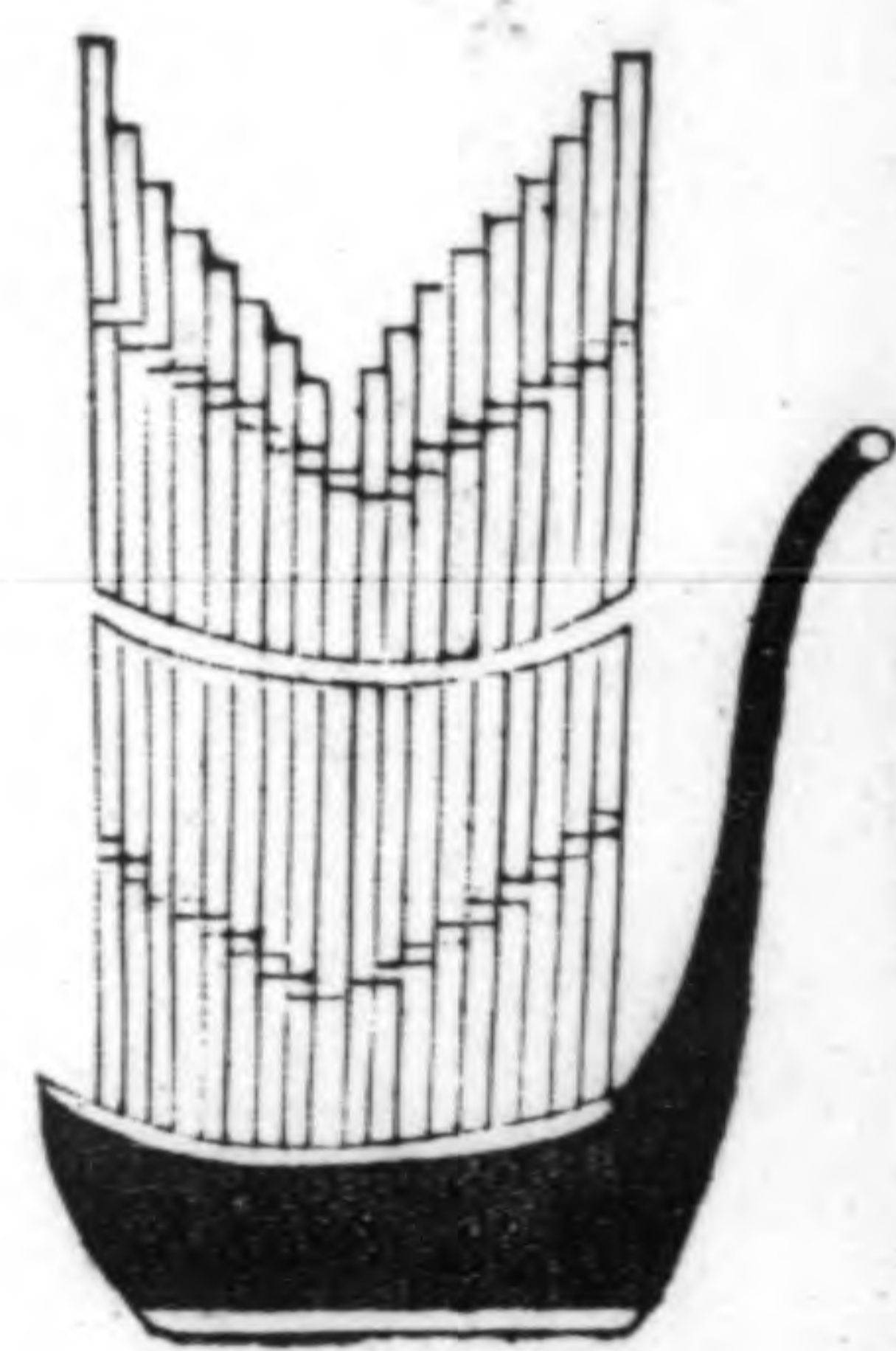

簾

簾竹為之長尺四寸圍三寸一孔上出寸三分橫吹之八孔又曰七孔

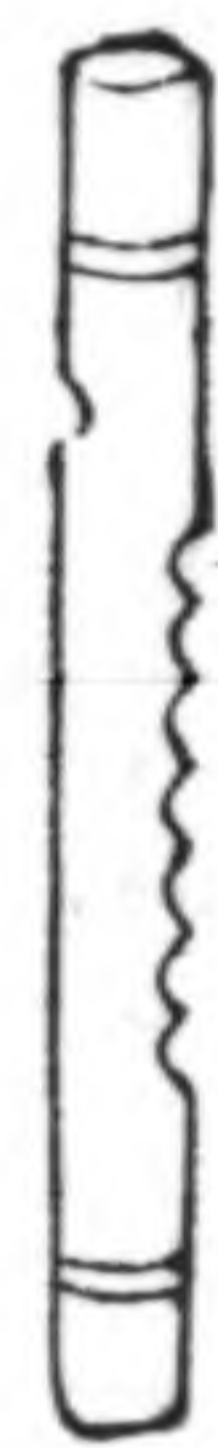

應

應長六尺五寸中有椎短者二三尺虛中筩無底端有兩空以手築地

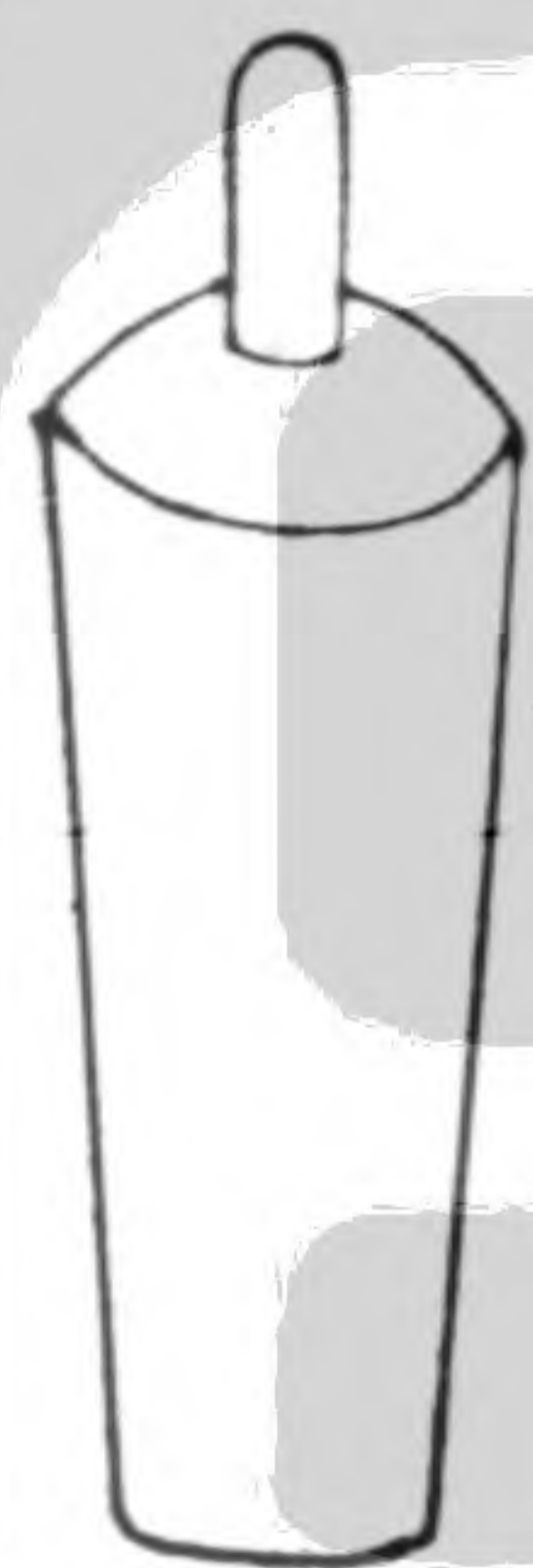

籥

籥如遂三孔



壎

土為之形如卵上圓而銳象天下平象地飾雲氣一孔吹之五孔出聲

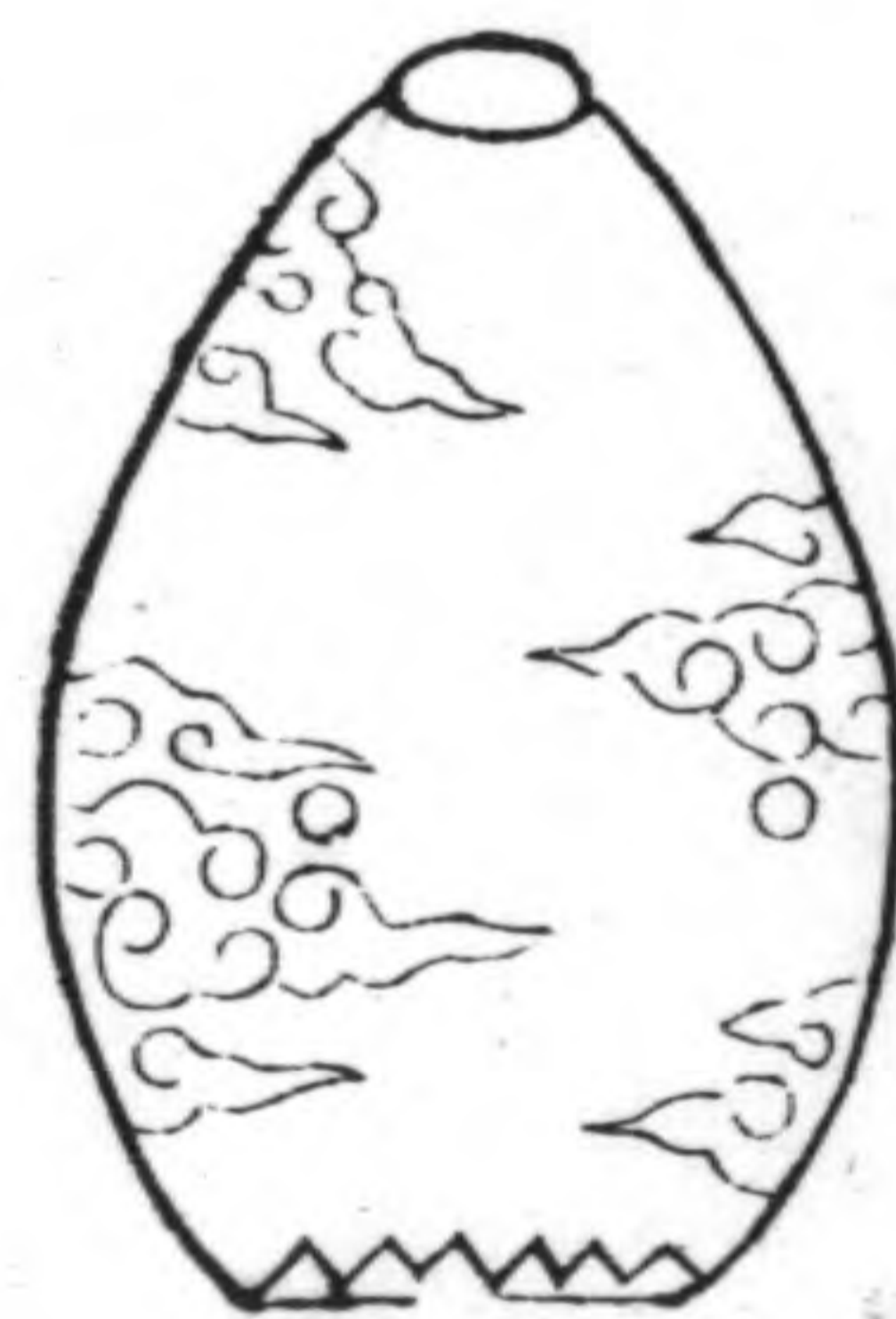

贗

贗以竹大五六寸長七尺端有兩孔髮畫以兩手築地



雅

雅如漆筩弁口大二圍長五尺六寸以羊韋鞞之兩紐疏畫

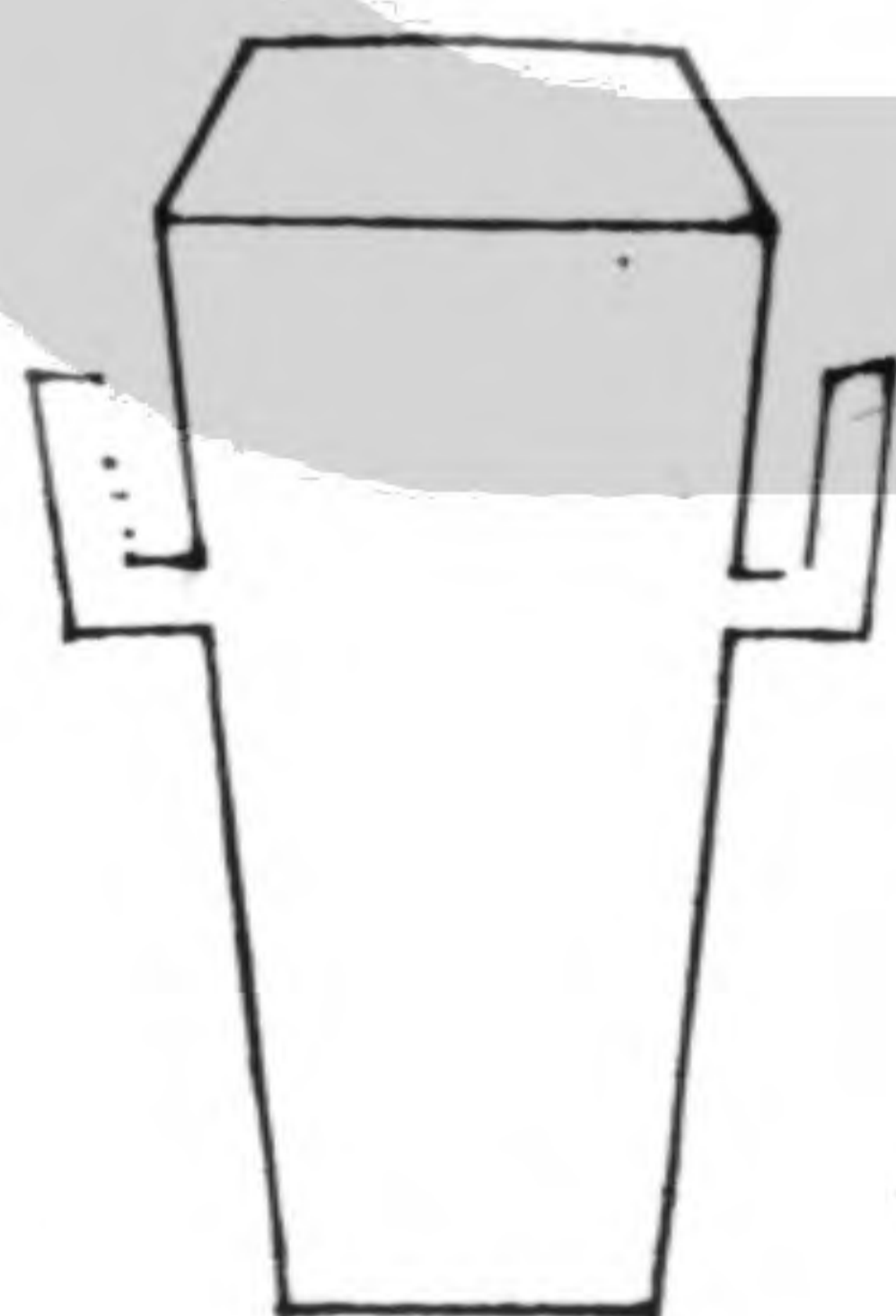

止

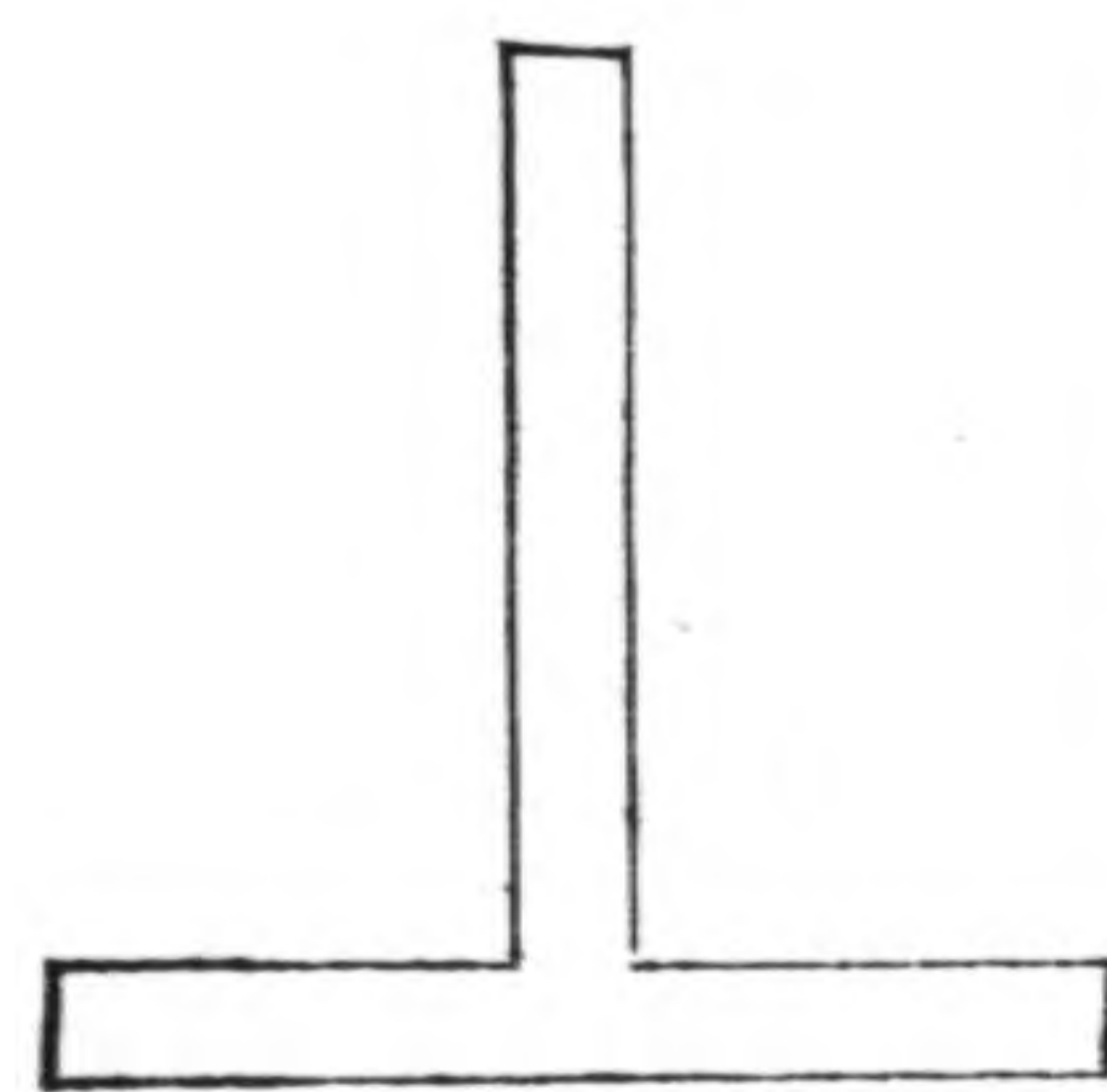

所以鼓祝謂之

籥



所以鼓敵謂之

鳧氏為鍾



兩樂曰鈺鈺間曰于于上曰鼓鼓上曰鈺鈺上曰舞舞上曰甬甬上曰衡鐘懸謂之旋旋蟲謂之幹鐘帶曰篆篆間曰枚枚謂之景于上之攏曰遂

銑鐘口兩角氣之上達謂于鼓則于上所擊處鈺在鼓上居鐘體之正舞在鈺上聲之震動于此者甬衡鐘柄也體以出聲柄以垂體甬在舞上取盡而有繼之意衡居甬上小于甬旋屬鐘柄所以縣之也以蟲為飾幹則彊而能屬鐘也帶則介于鼓鈺舞甬衡之間凡四枚鐘乳也夾鼓與舞凡三十一乳似大星又謂之景攏則所擊之處攏弊也遂在鼓中窪而生光

鼓人四金圖

鐃



鼓人以金鐃和鼓鐃于也圓如碓頭大小下樂作鳴之與鼓相和

鐃

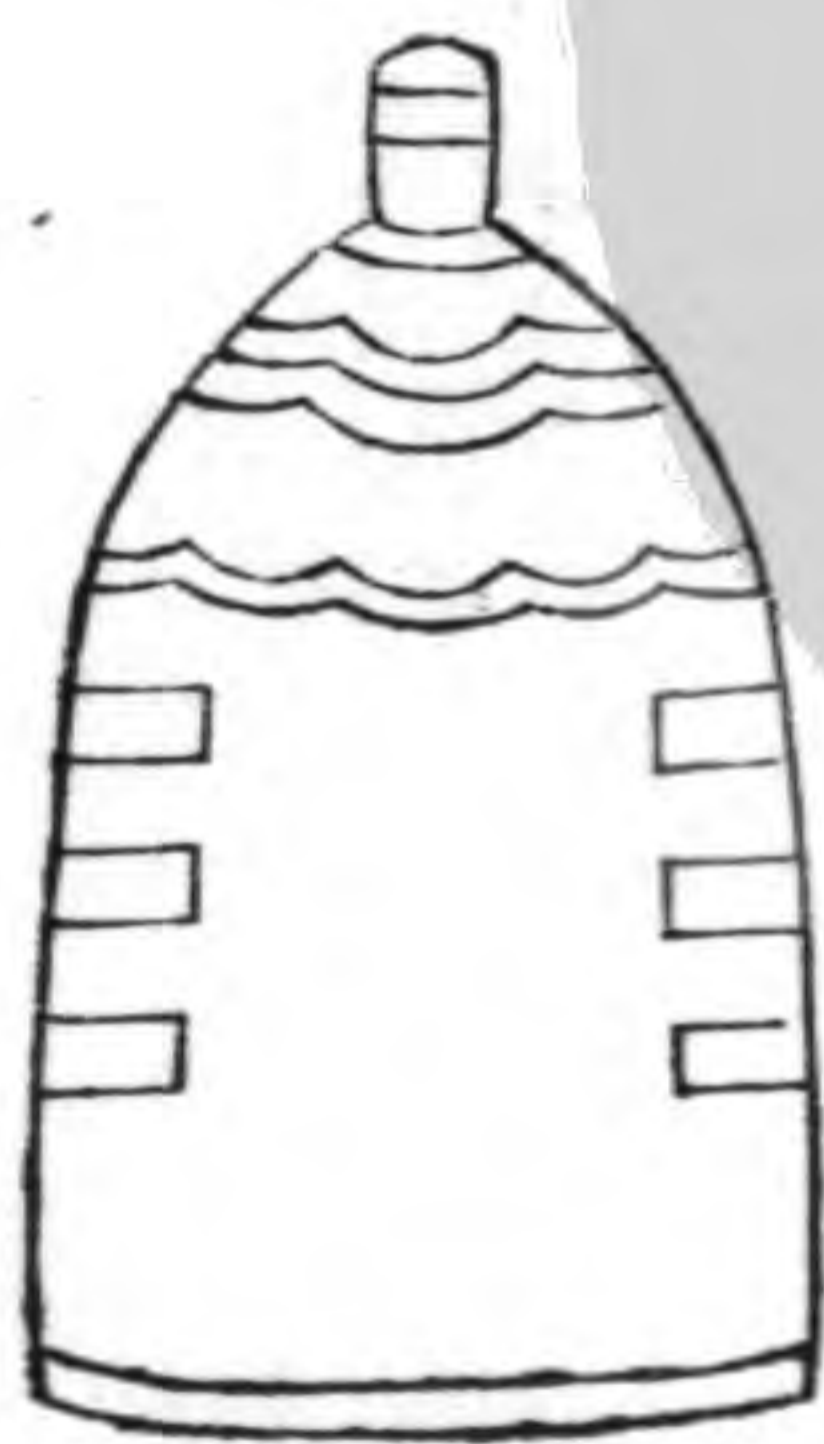

鼓人以金鐃節鼓鐃也形如小鐘軍行鳴之以為鼓節

鐃

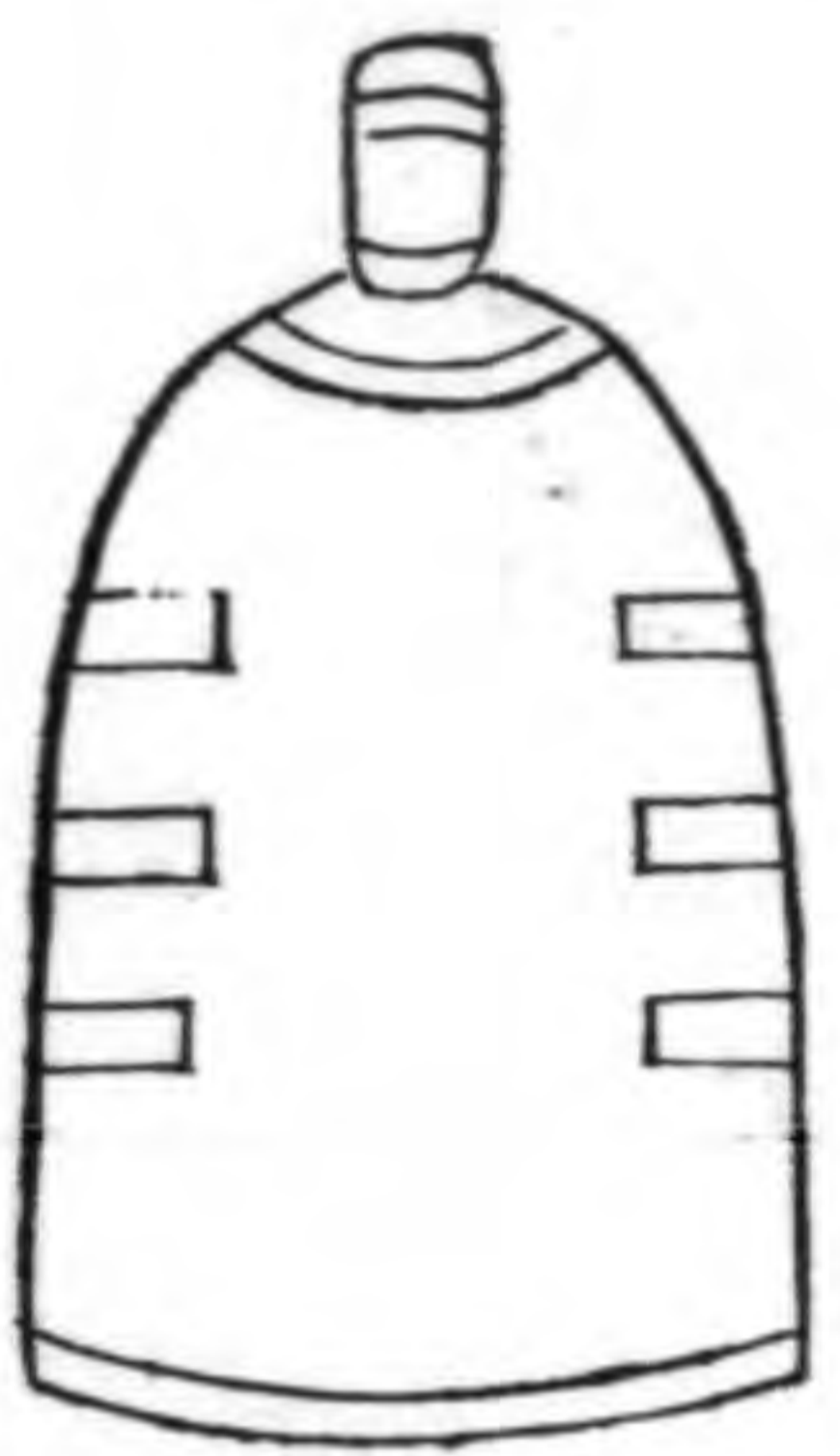

鼓人以金鐃止鼓鐃如鈴無舌有秉執而鳴之以止擊鼓

鐃

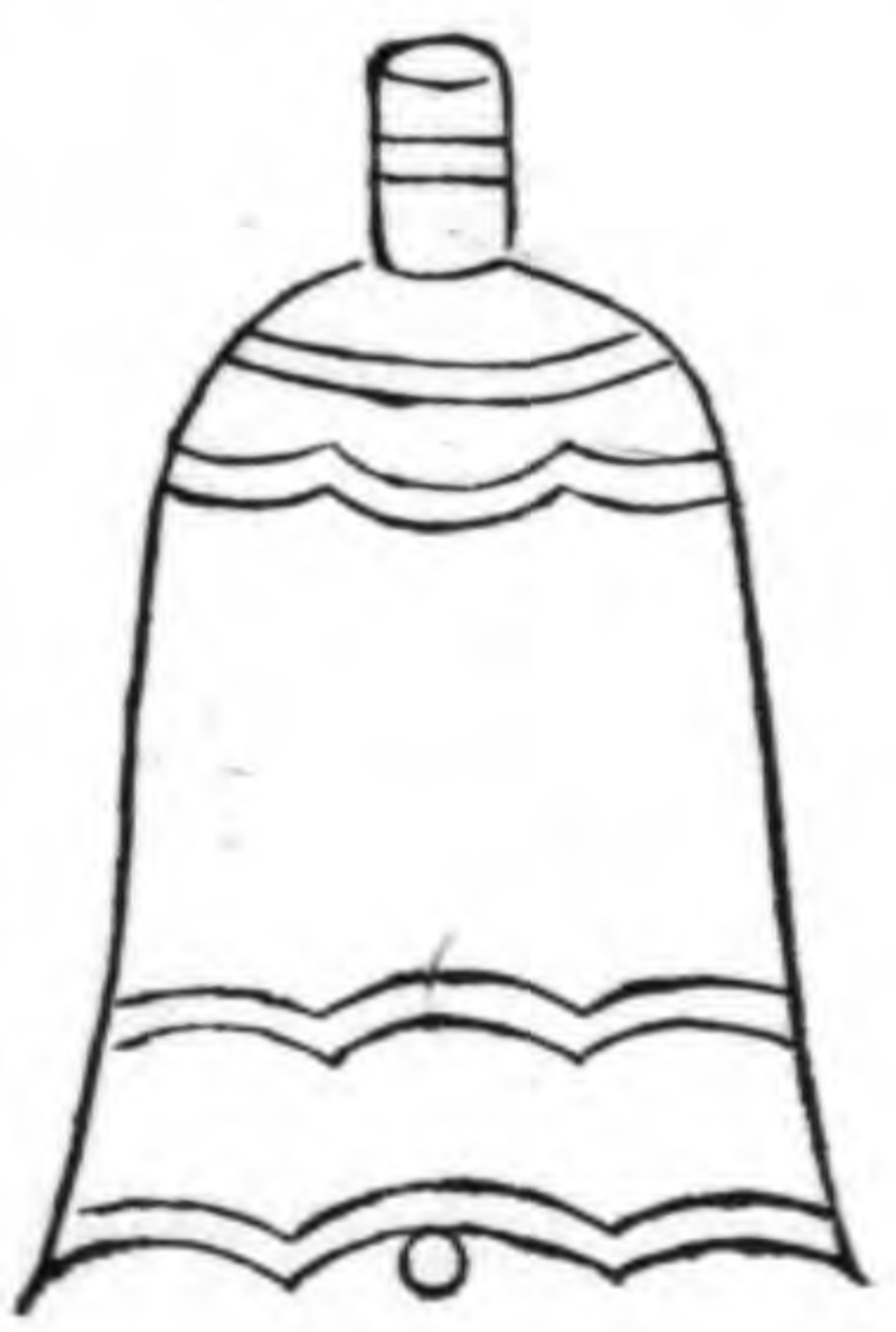

鼓人以金鐃通鼓鐃大鈴也振之以通鼓

舞制圖

舞兵

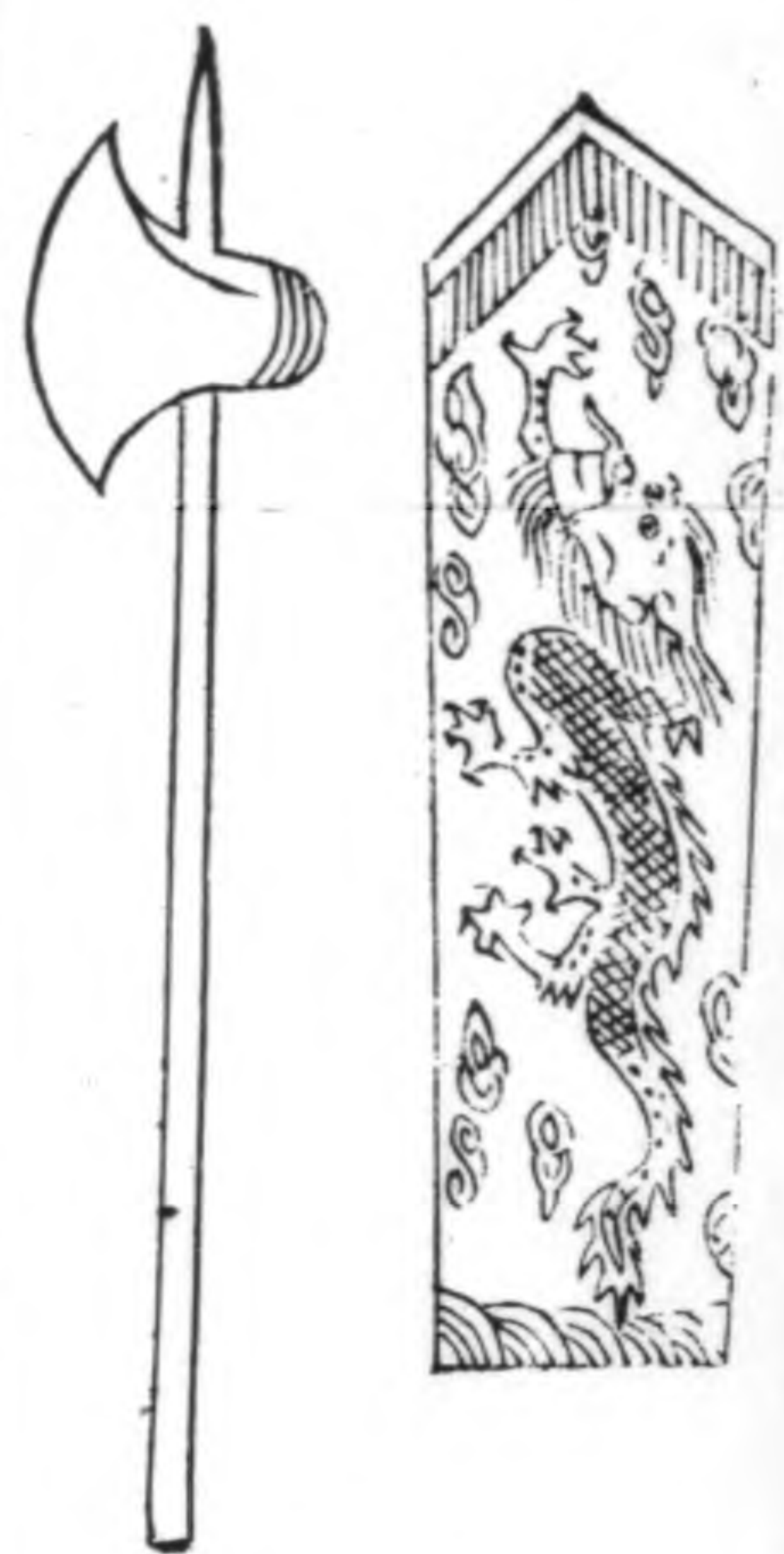

兵謂干戚也舞師教
兵舞帥而舞山川祭
祀樂師有干舞

舞帔

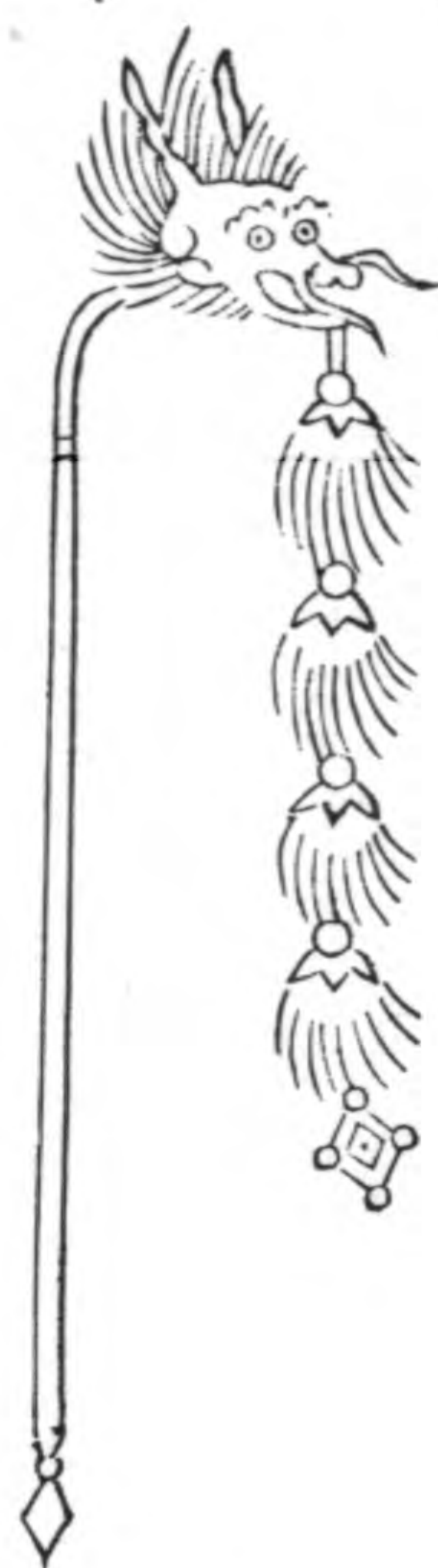

帔列五采繒為之有
秉舞師教帔舞帥而
舞社稷之祭祀

舞羽

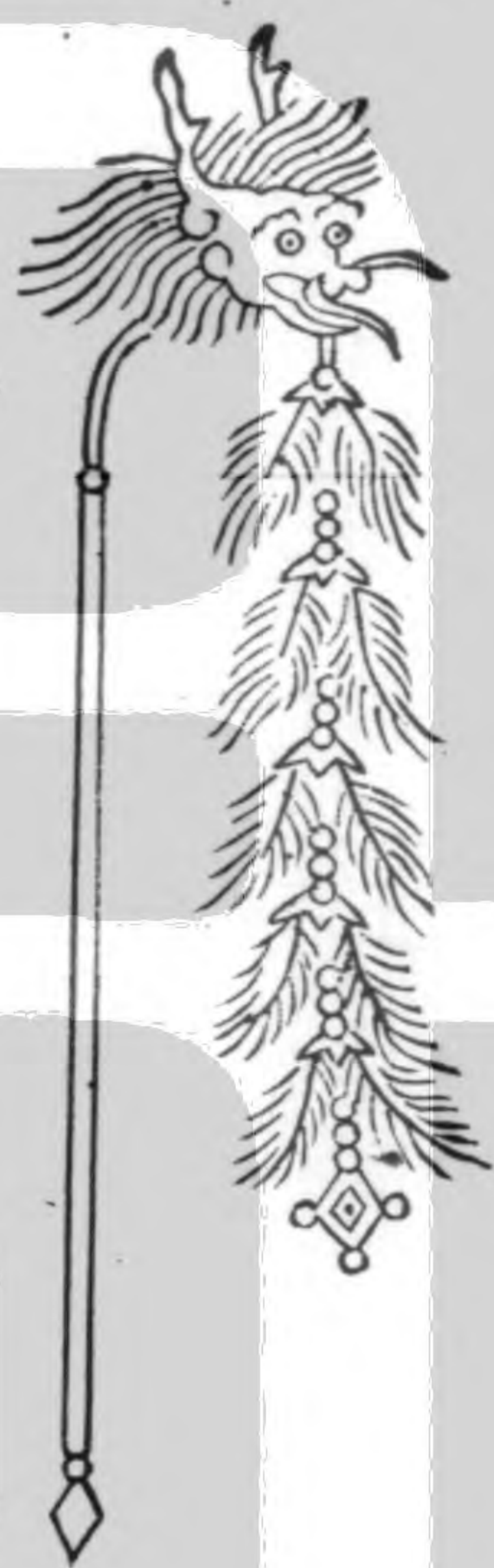

羽析白羽為之形如
帔舞師教羽舞帥而
舞四方之祭祀

舞皇



皇謂雜五采羽如鳳
皇色舞師教皇舞帥
而舞早暎之事

舞旄



樂師教小舞旄舞以
鼈牛毛為之

舞人



人舞無所執以手袖
為威儀祭宗廟則舞
之

鼓制圖

鼓建

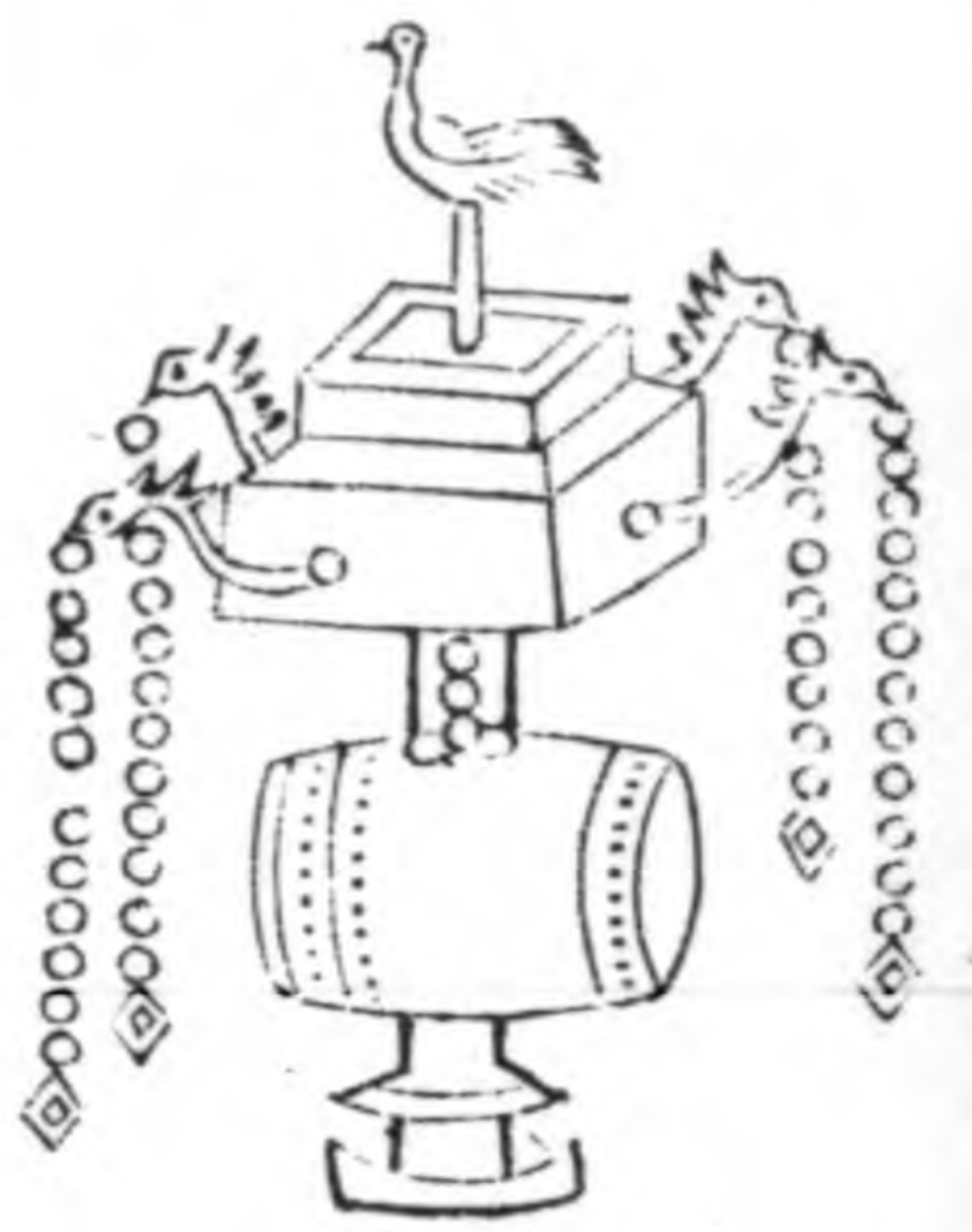

大射云建鼓在阼階西南建猶樹也木貫而樹之

鼓晉

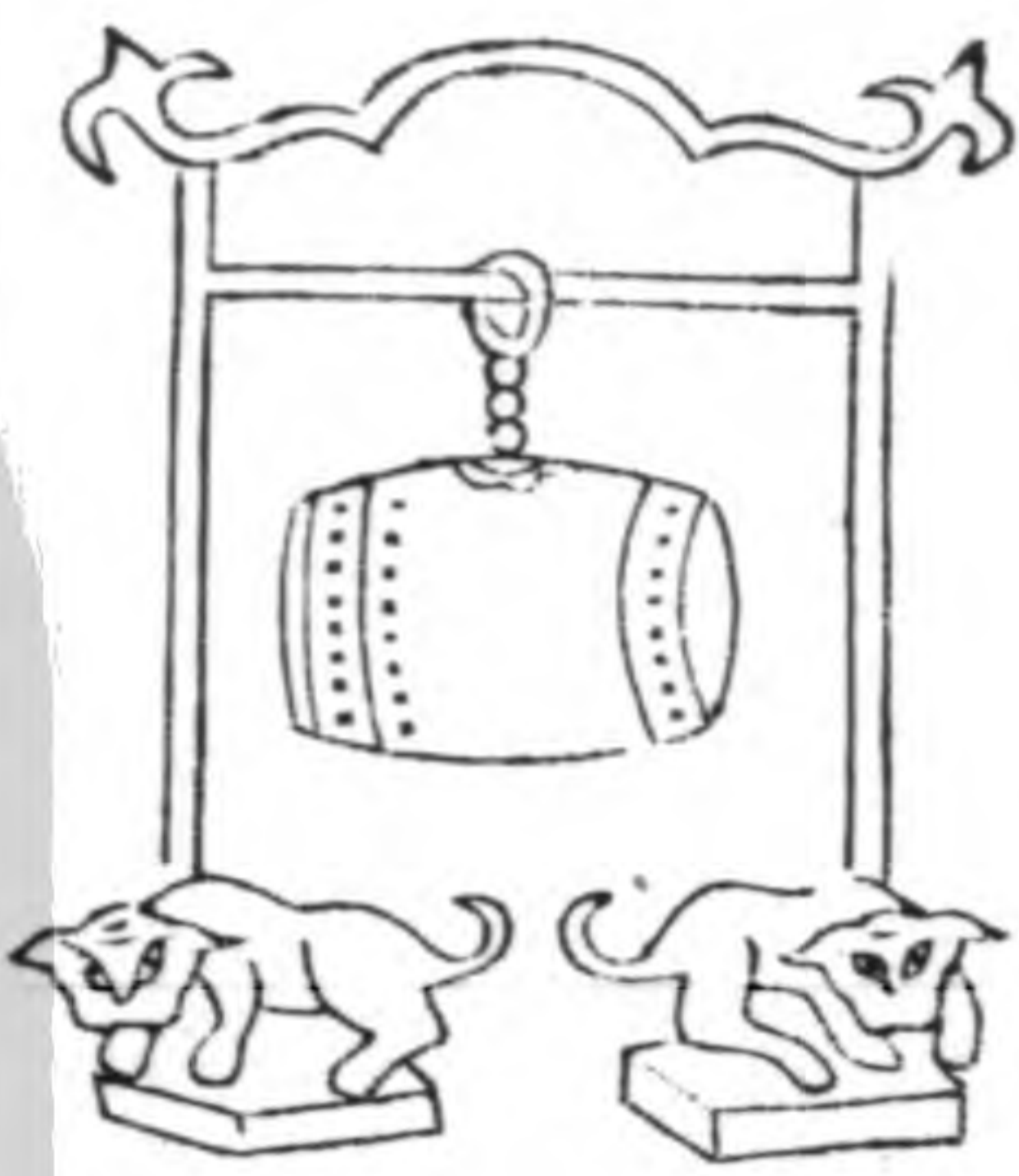

鼓人以晉鼓鼓金奏晉鼓長六尺六寸

鼓鼗



鼓人以鼗鼓鼓軍事大鼓謂之鼗長八尺鼓四尺中圍加三之一

鼓路

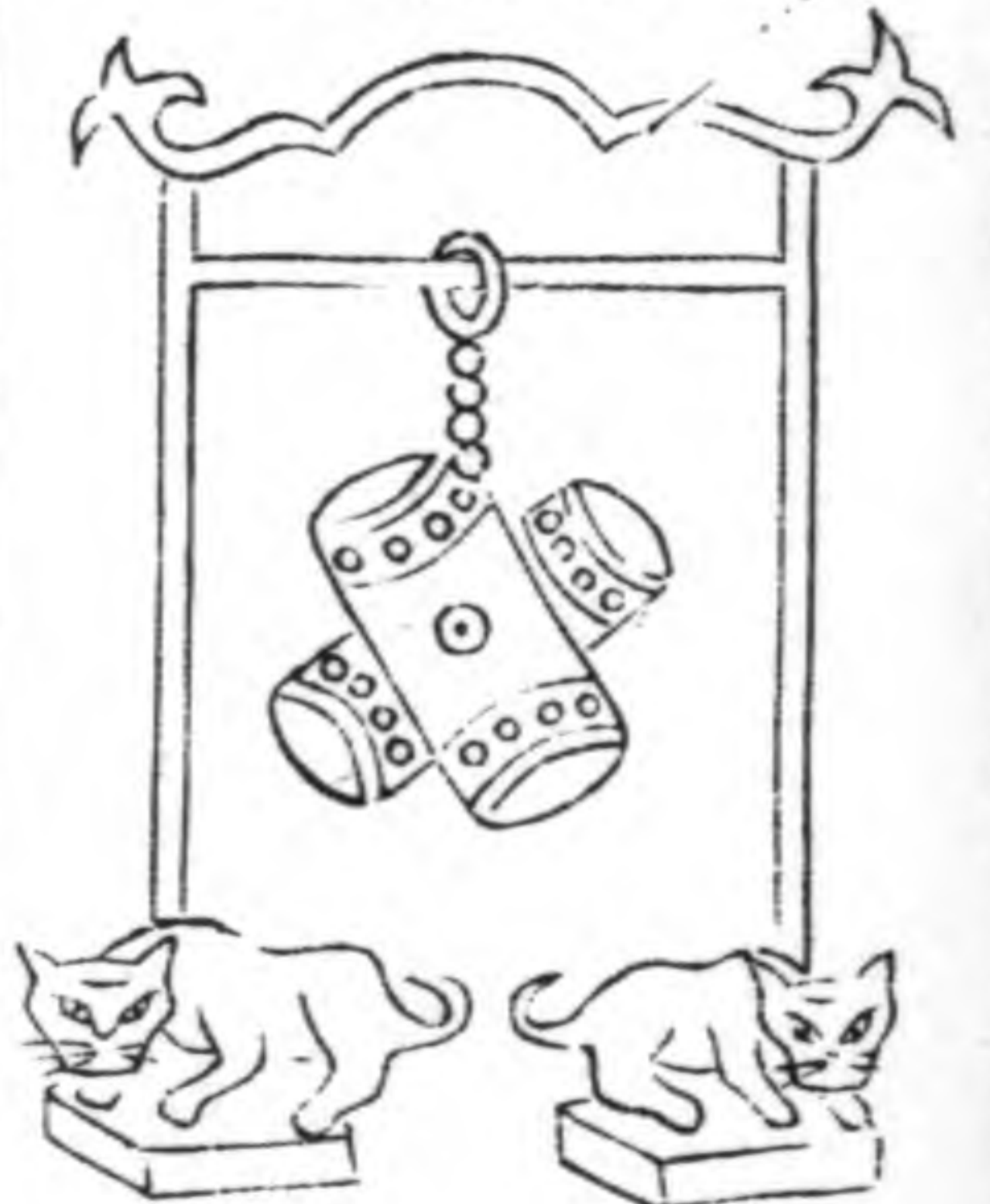

鼓人以路鼓鼓鬼享四面鼓也鬼享享宗廟也

鼓雷

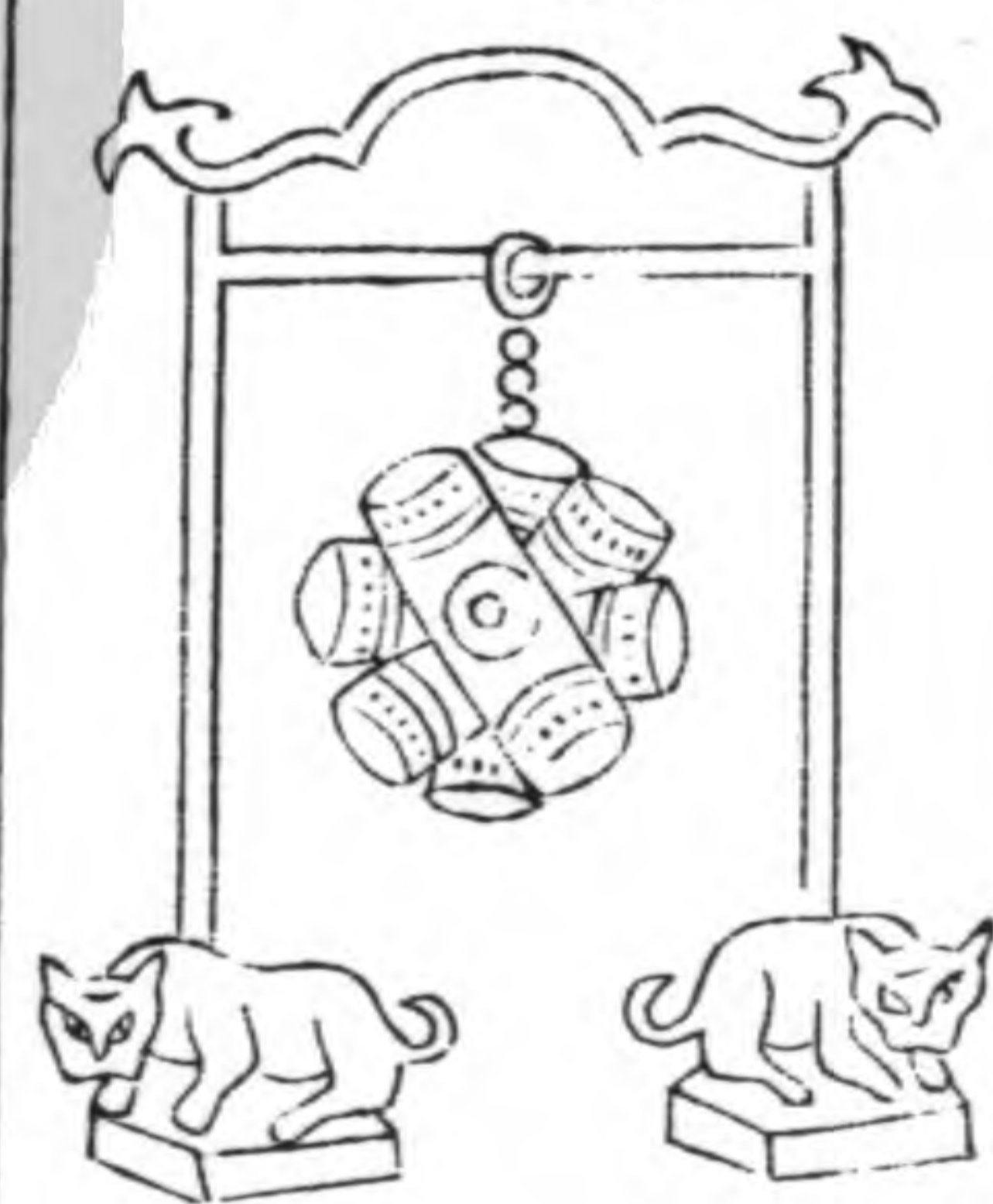

鼓人以雷鼓鼓神祀八面鼓也神祀祀天神也

鼓鼙

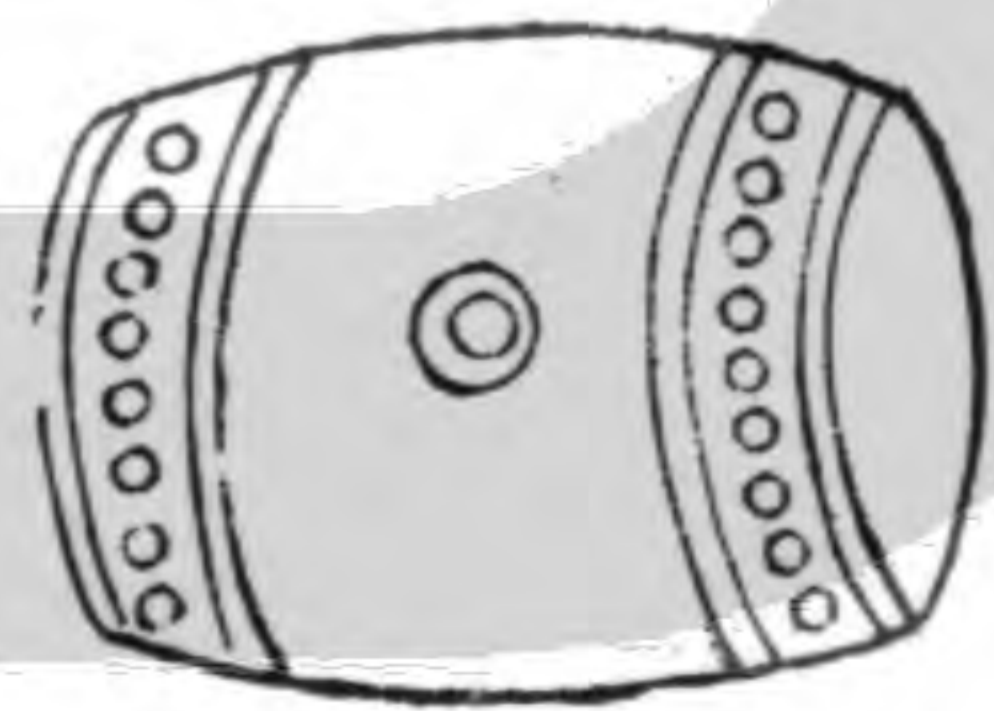

鼓人凡軍旅夜鼓鼙鼙夜戒守鼓也長丈二尺

鼓靈

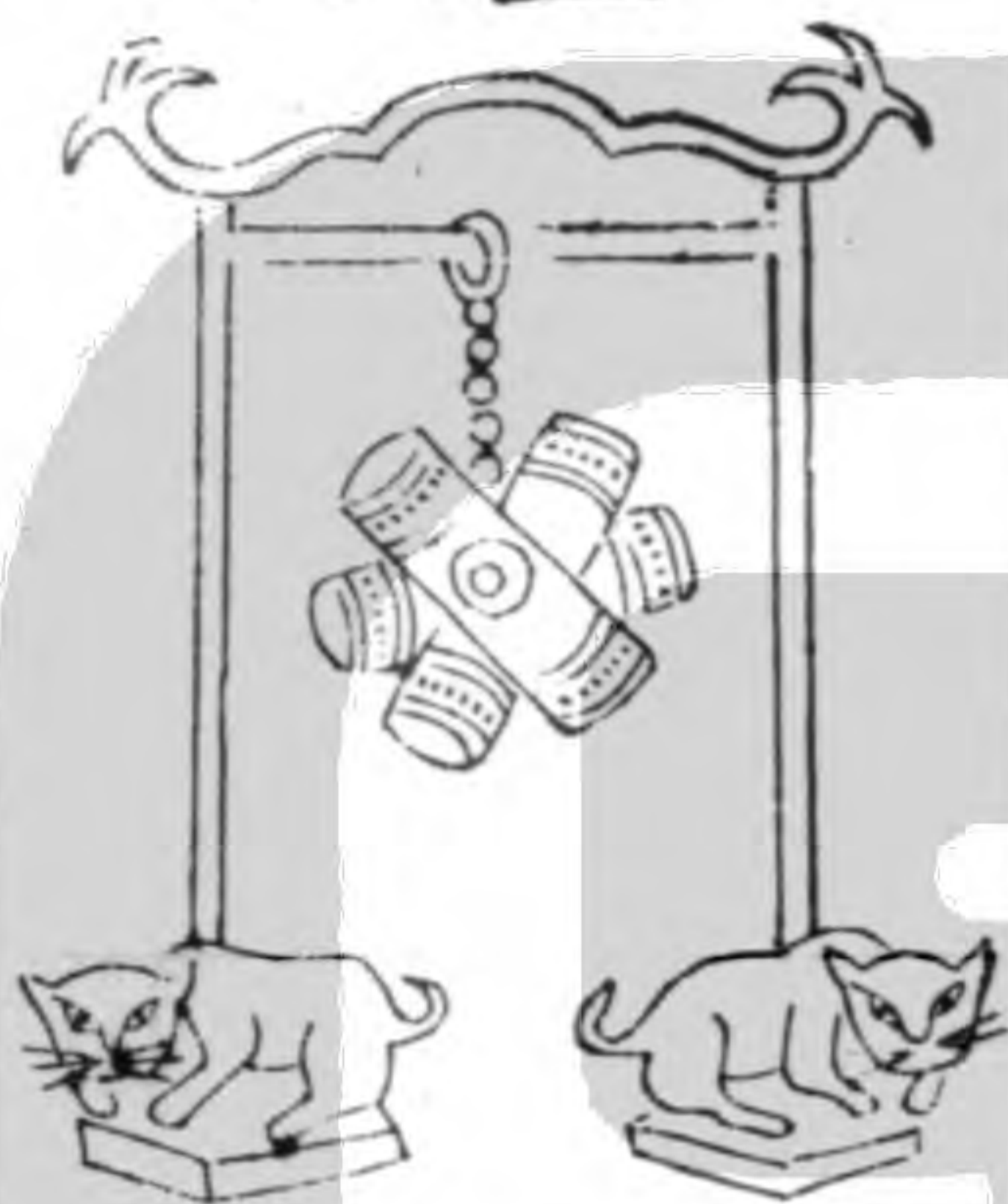

鼓人以靈鼓鼓社祭祭地社祭祭地示也

鼓鼗

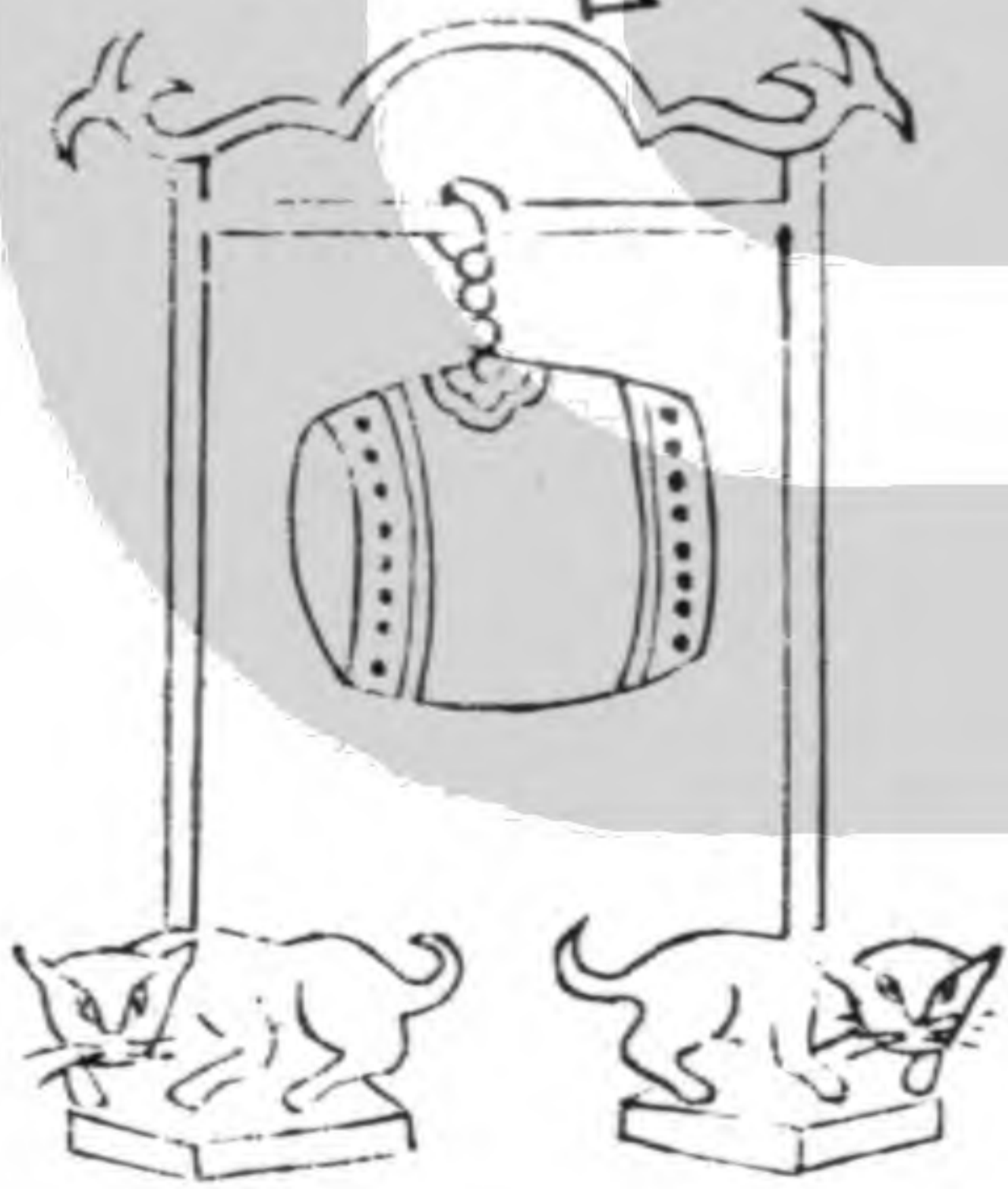

鼓人以鼗鼓鼓役事鼗鼓長丈二尺

鼓提

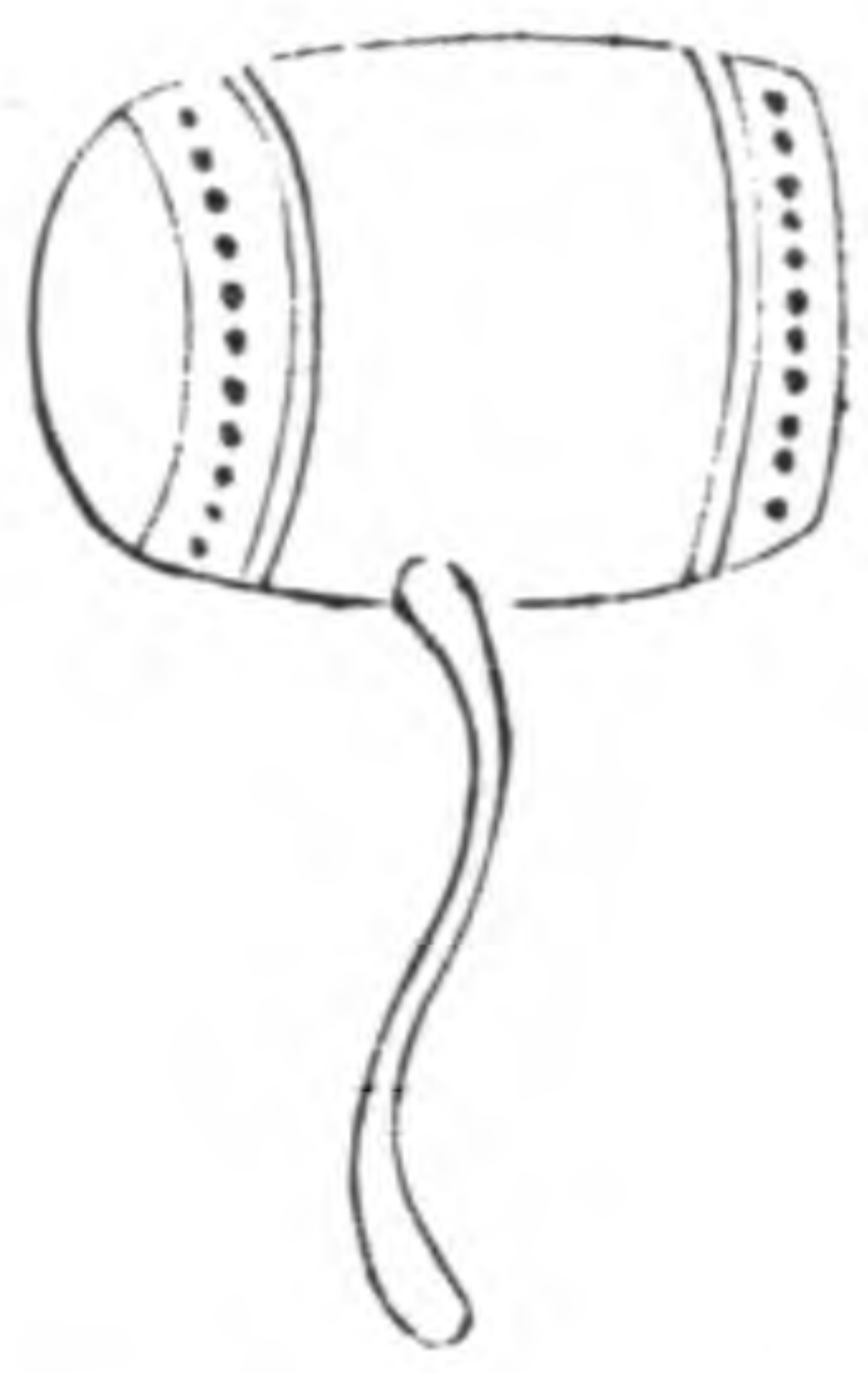

大司馬師帥執提馬上鼓有曲木提持鼓立馬鬣上者曰提

鼓鼗



小師掌教鼓鼗制如鼓而小持其柄搖之

鼓鞀

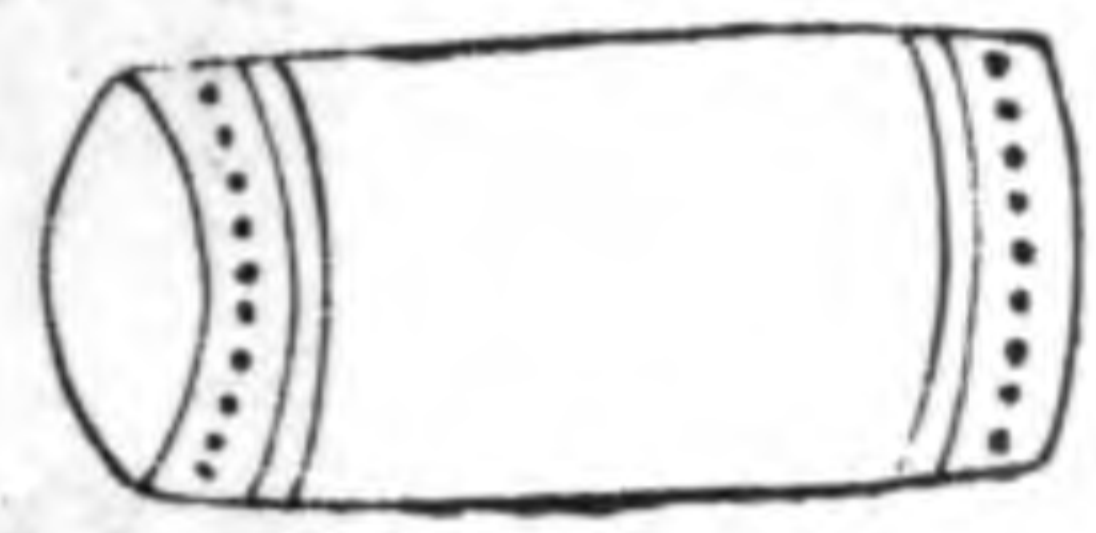

大師令奏鞀鼓小師鼓鞀小鼓也為大鼓先引讀為引導之引

禮器圖

籩

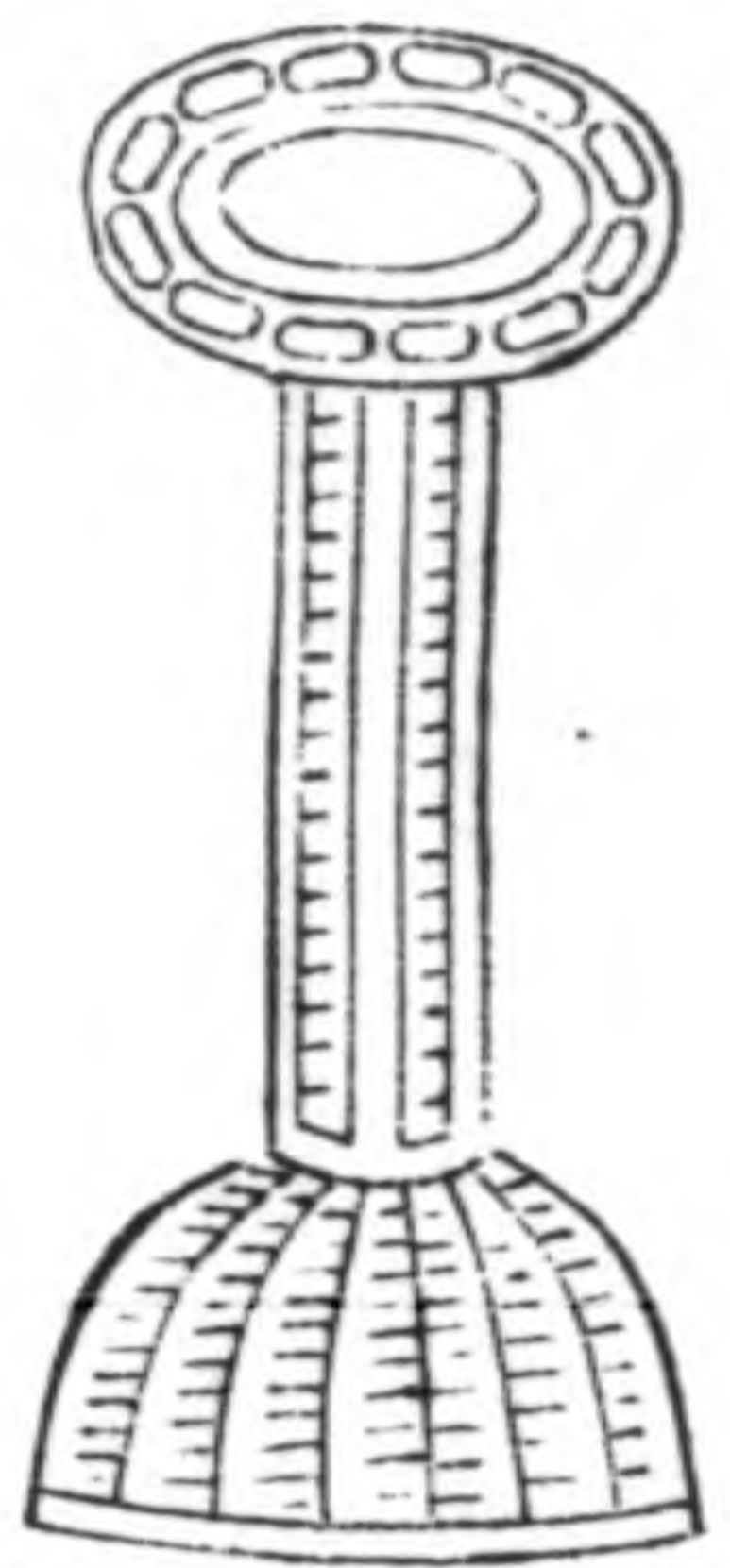

籩以竹為之
口有滕緣形
制如豆受四
升

豆



旒人為豆高
一尺以木為
之受四升口
圍徑尺二寸
有益

簠

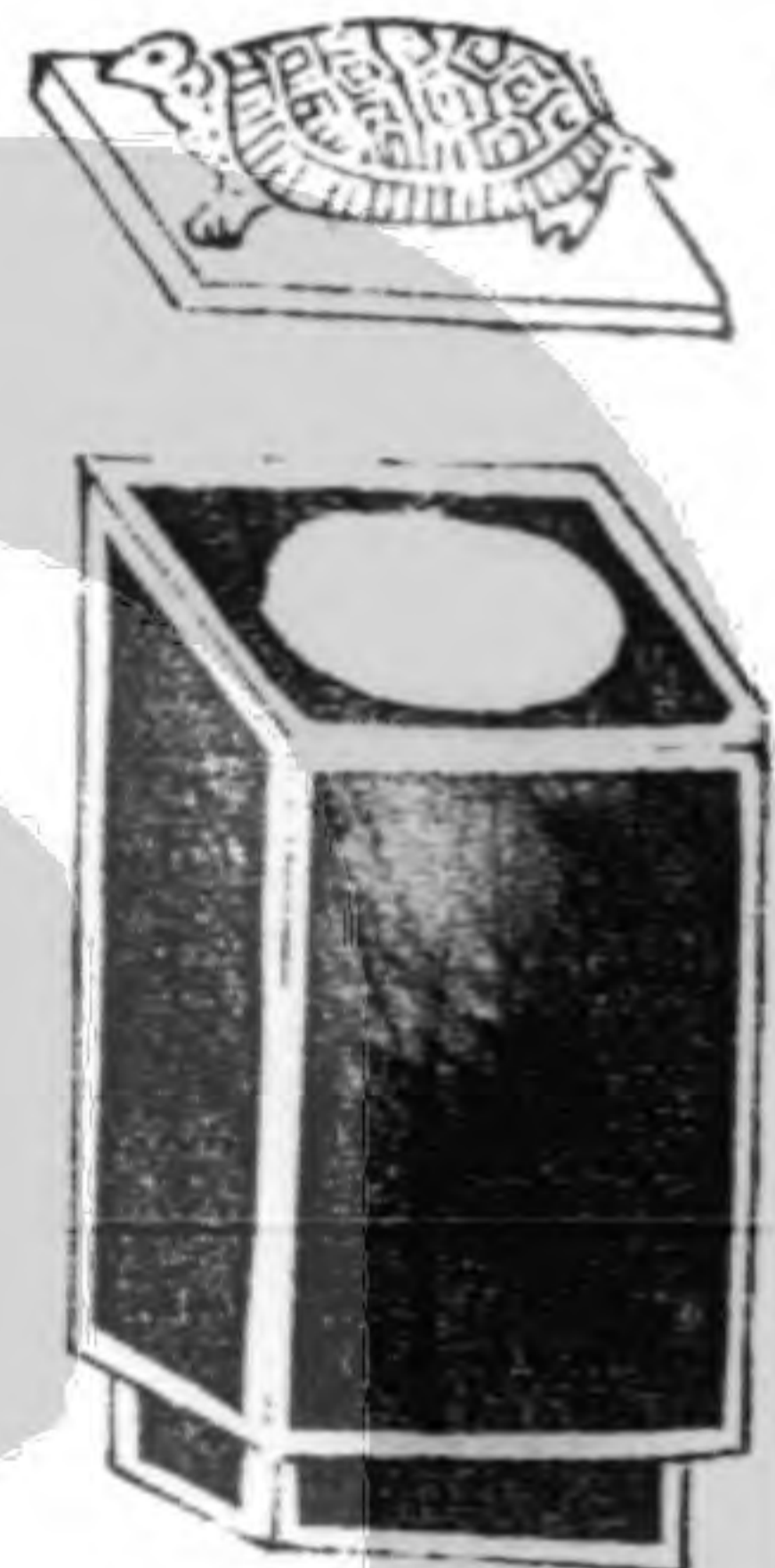

外方內圓曰
簠容一斗二
升稻梁器

簋



內方外圓曰
簋亦受斗二
升盛黍稷

鼎



鼎有牛羊豕
皆以銅天子
飾以黃金侯
飾以白金大
夫無飾士以
鐵

觚

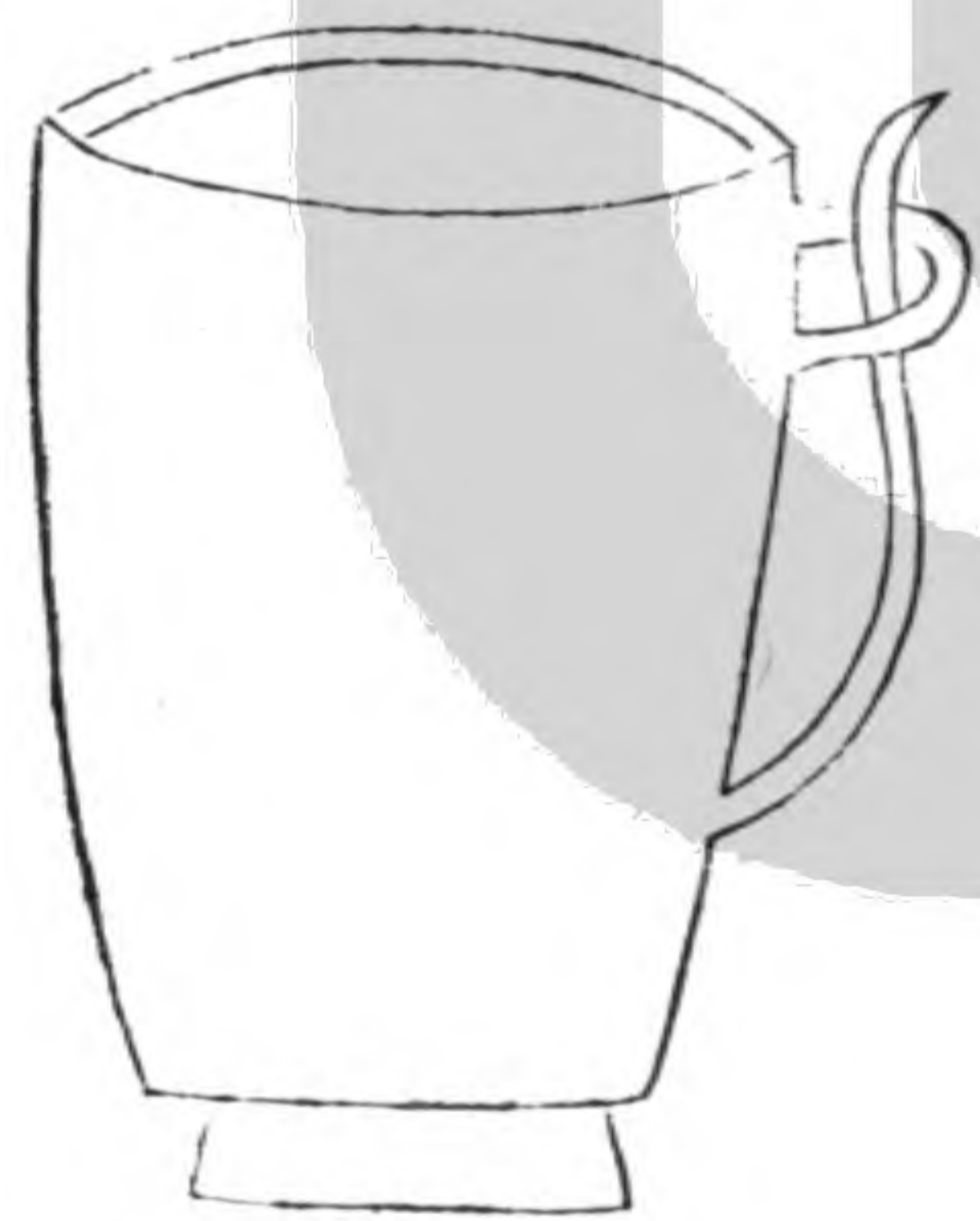

觚銳下方足
漆赤中畫青
雲氣容二升

琖槃



槃以木為之
王府云若合
諸侯則供珠
槃玉散當用
珠玉為飾耳

龍勺 酌鬱



柄長二尺四
寸龍頭受五
升

酒壺

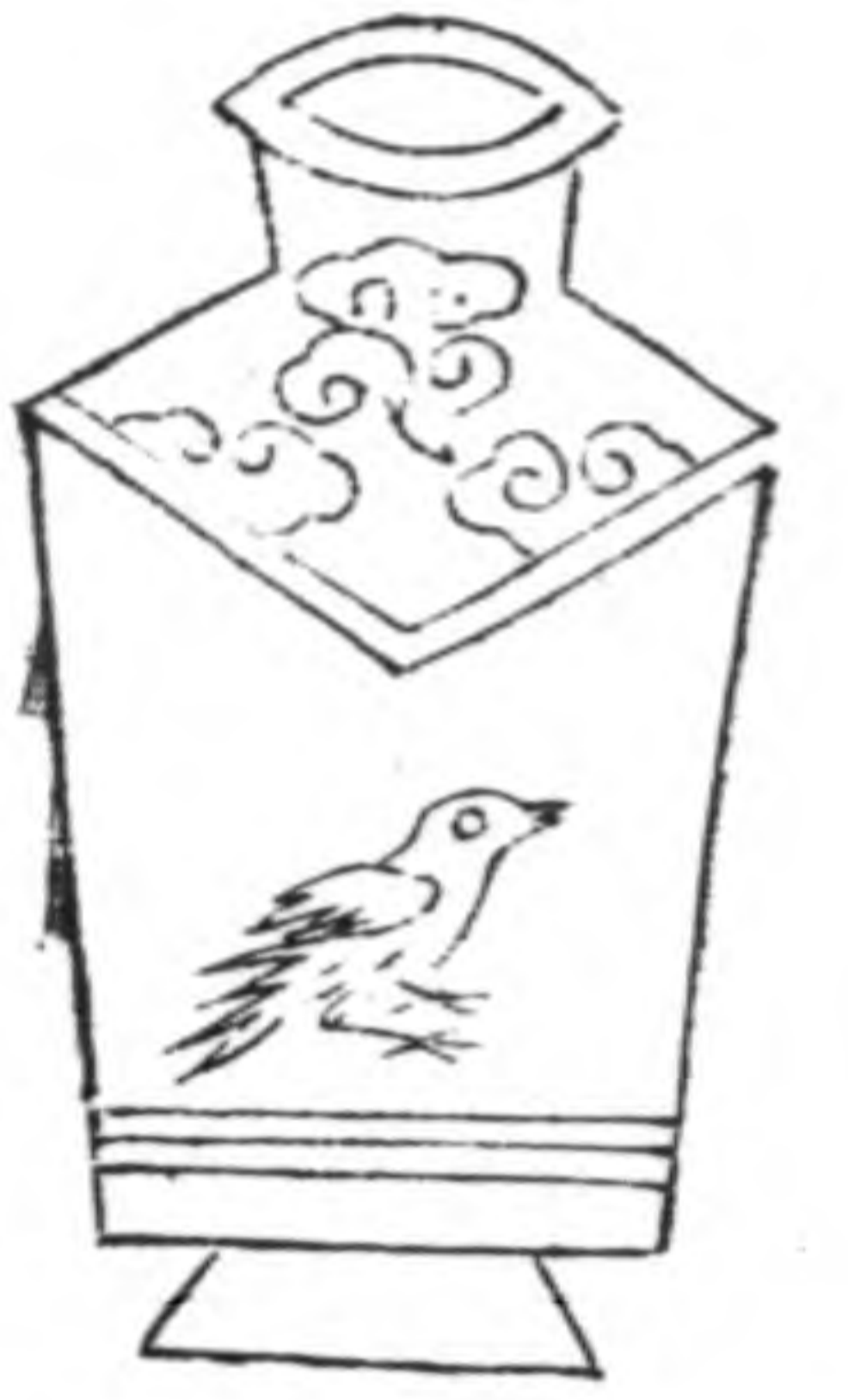

壺禮器腹方
口圓曰壺有
爵飾約容一
升

甕

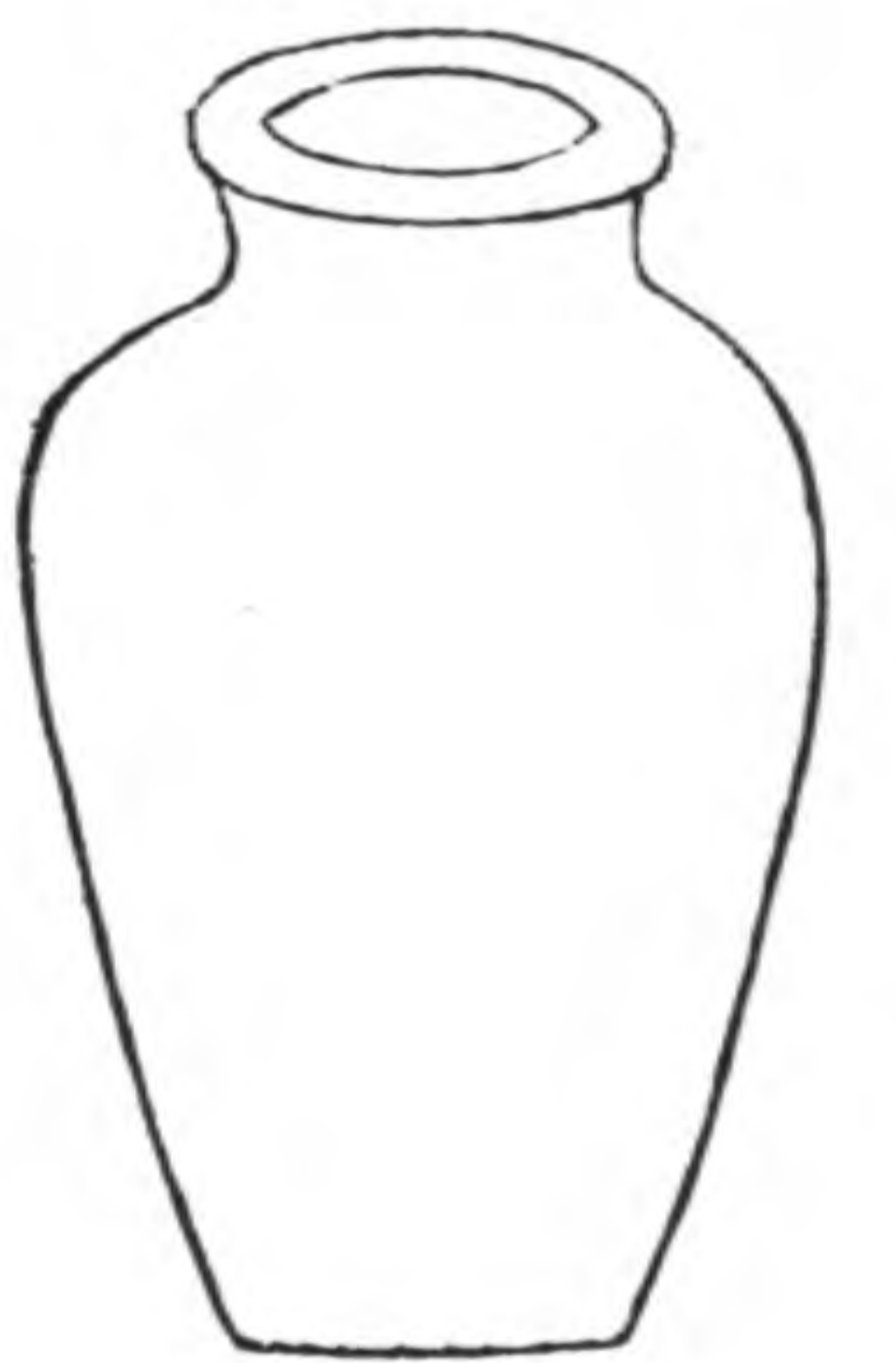

甕以盛醢醢
高一尺受二
斗

釜

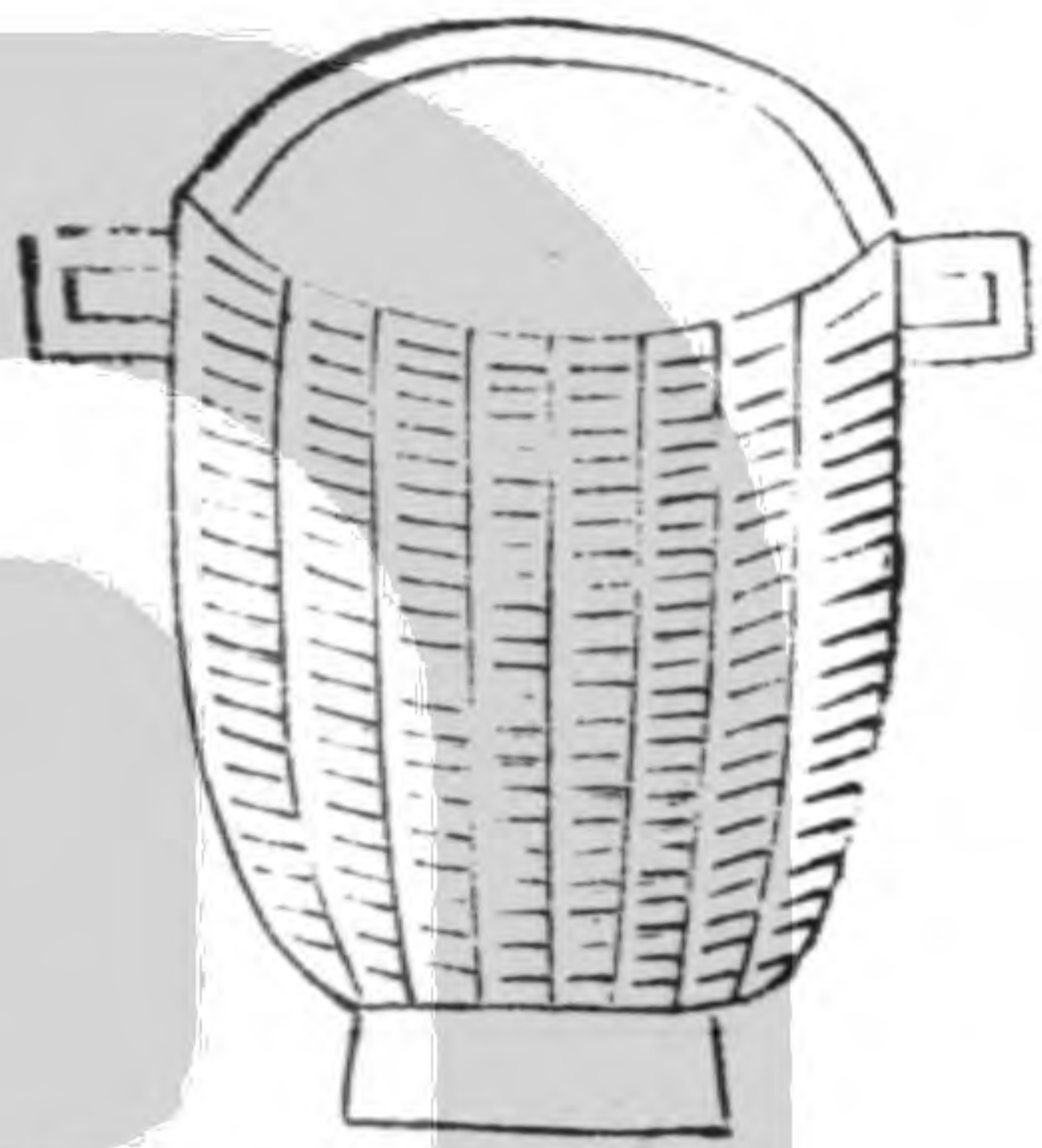

釜量名容六
斗四升

方壺



方壺受一斛
腹圓口足皆
方圓壺受同
腹方口足皆
圓中畫雲氣

俎

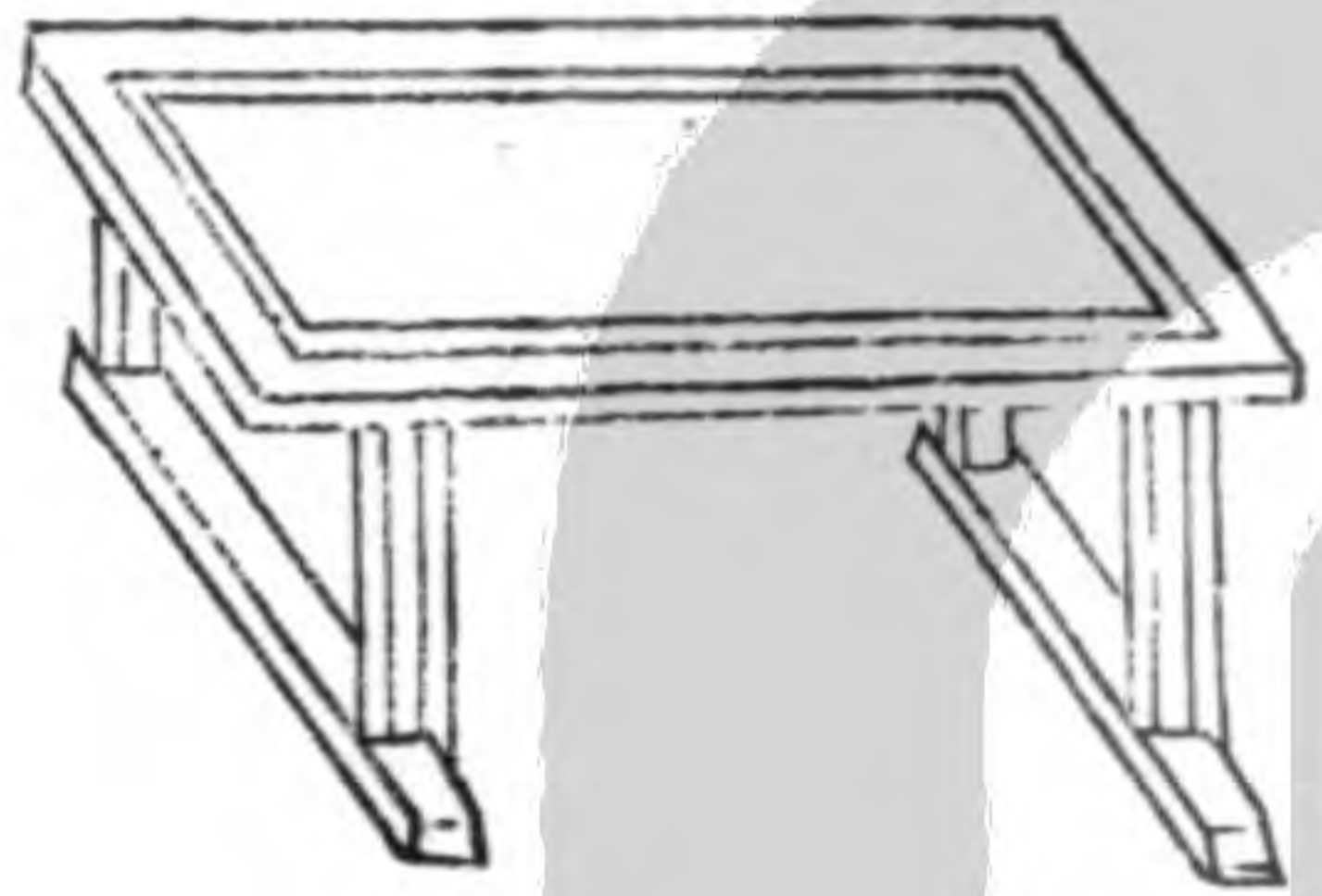

周制房俎載
牲之器長二
尺四寸廣尺
二寸高一尺

罍



形似壺大者
受一斛刻木
為之畫為山
雲之形

畫布巾



畫五色雲氣
冪六彙二尺
二寸之幅而
圓祭宗廟尚
文也

䟽布巾

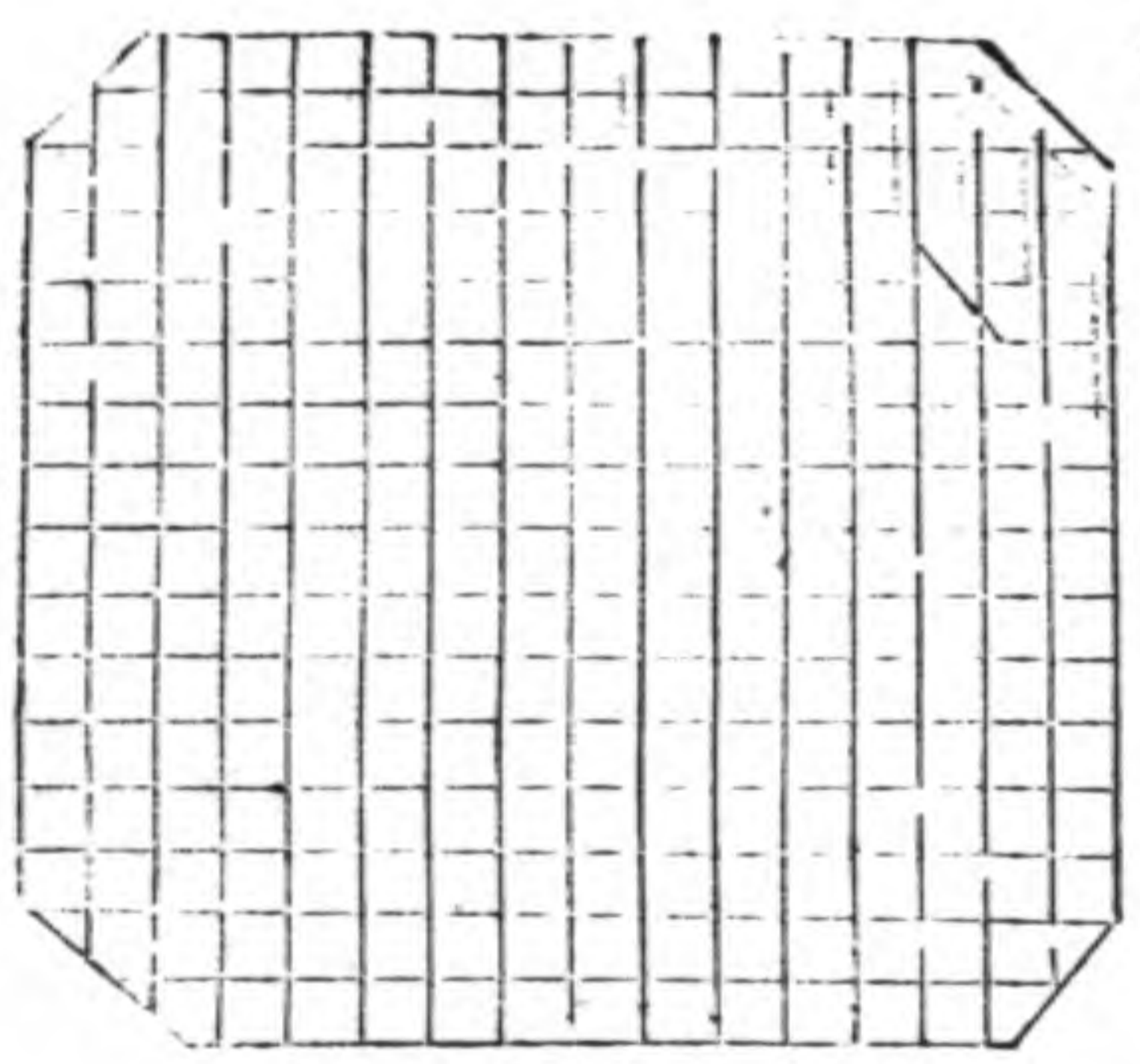

䟽布巾冪八
尊二尺二寸
祭天地用之
尚質也

玉爵



玉爵受一升
象爵之形中
有鬯酒又持
之也取其能
飛而不溺於
酒之意

筥



圓曰筥受半
斛以盛米

登



詩云于豆于
登尾為之形
與豆同但畫
飾異耳

柶

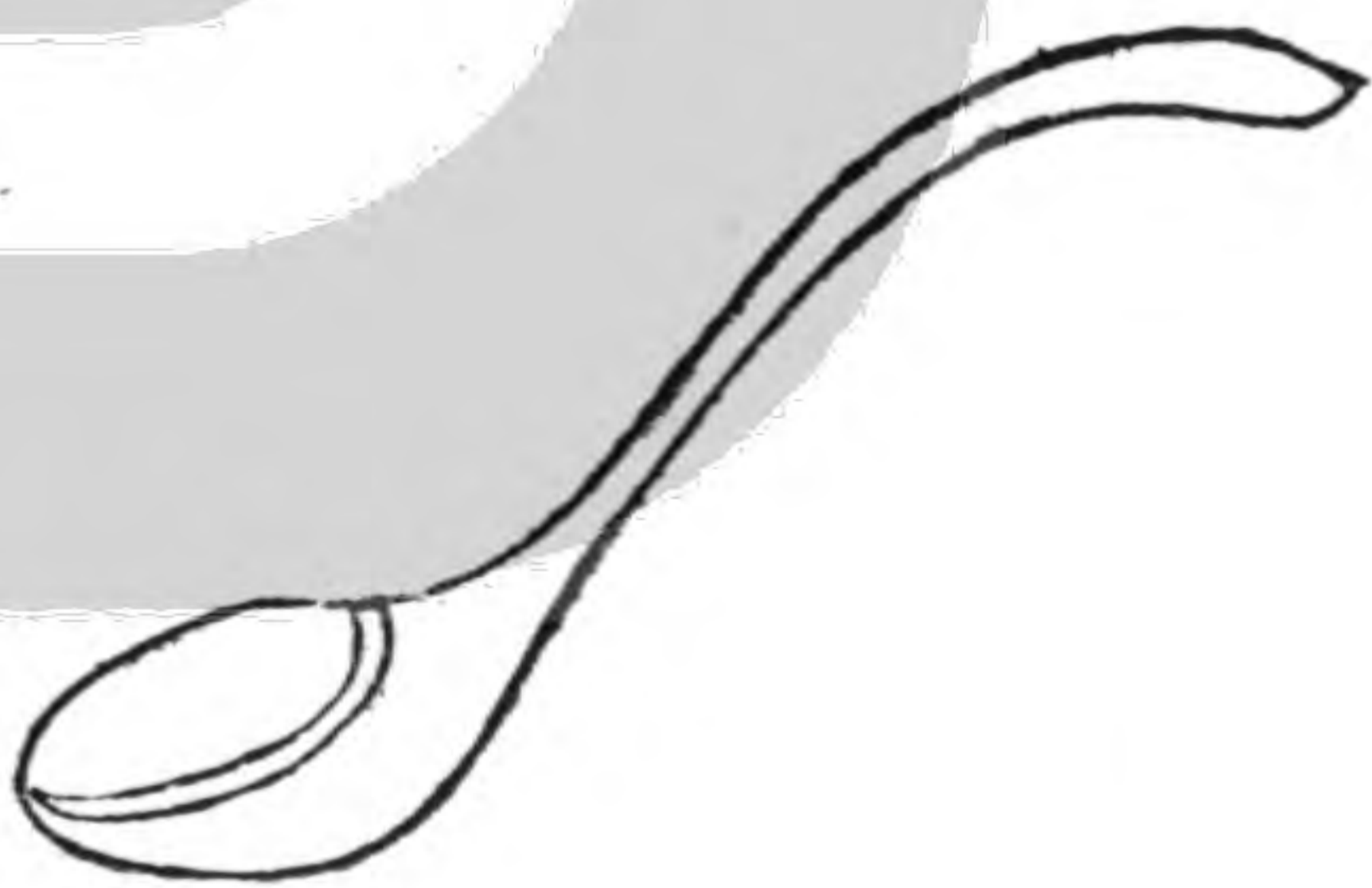

醴有柶用角
為之鋤有柶
用木為之柶
長一尺攪博
三寸

輪人為蓋



蓋斗曰部部徑六寸厚一
寸上隆一分斗下達常長
二尺徑一寸達常下八寸
杠長八尺徑二寸足以合
常也用弓二十有八每弓
長六尺廣四分先鑿部為
二寸十八空乃置弓於空
端即大一分其弓近部二
尺稍平外四尺即撓之漸
漸下曲而爪末低二尺死
以低二尺者謂杠與達常
共高一丈八尺故四
面宇曲下低二尺也蓋之
寬狹唯可覆軹不及于轄

六尊圖

尊獻



春祠夏禴
朝踐用兩
獻尊一盛
玄酒一盛
醴齊並刻
全牛之形

尊壺



秋嘗冬烝
饋獻用兩
壺尊一盛
玄酒一盛
醴齊受五
斗漆赤中

尊象



春祠夏禴
其再獻用
兩象尊一
盛玄酒一
盛盞齊以
象骨飾尊

尊太

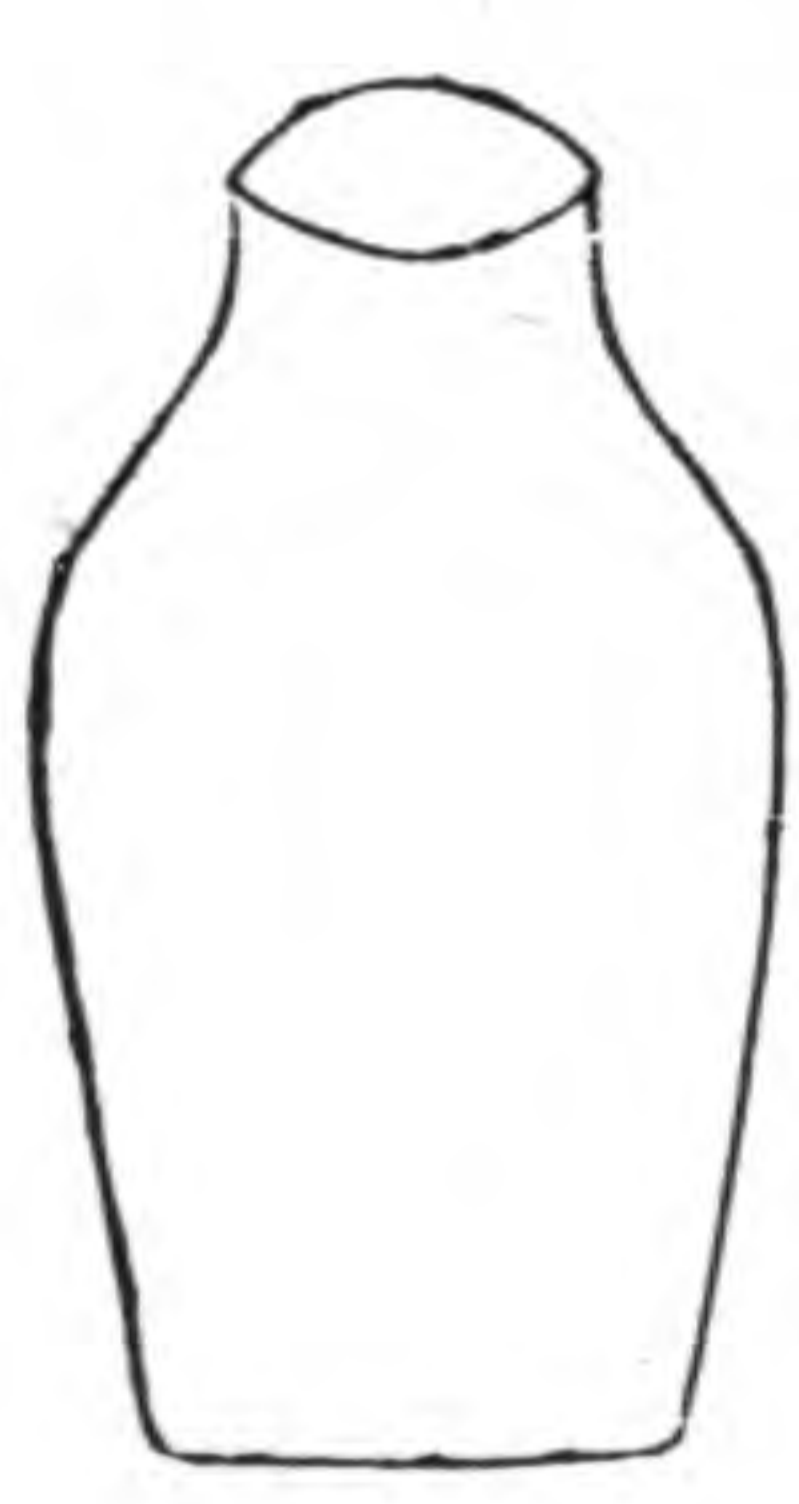

追享朝享
朝踐用兩
太尊一盛
酒盛醴齊
即太古之
瓦尊也

尊著



秋嘗冬烝
朝獻用兩
著尊著著
地無足與
獻尊象尊
容受同

尊山



追享朝享
再獻用兩
山尊一盛
玄酒一盛
盞齊刻畫
山雲形

六彝圖

彝雞



春祠夏禴裸
用雞彝鳥彝
刻畫為雞鳳
凰之形受三
斗盛明水

彝黃



秋嘗冬烝裸
用學彝黃彝
皆有舟盛鬱
鬯黃金為目

彝鳥



同雞彝盛鬱
鬯鳥即畫鳳
凰形于尊上
鳴鳥謂之鳳
皇故也

彝虎



追享朝享裸
用虎彝雌彝
皆有舟虎彝
盛明水畫虎
為飾

彝罍



罍彝盛明水
罍讀稼謂畫
禾稼于尊也
彝與舟並漆
赤中

彝雌



雌彝盛鬱鬯
雌印鼻似獼
猴長尾末有
岐鼻向上兩
即以尾塞鼻

六幣圖

圭以馬



二王後享天子用圭故合圭以馬取特達之意

璋以皮



二王後享天子用璋故合璋以皮示服猛也

琮以錦

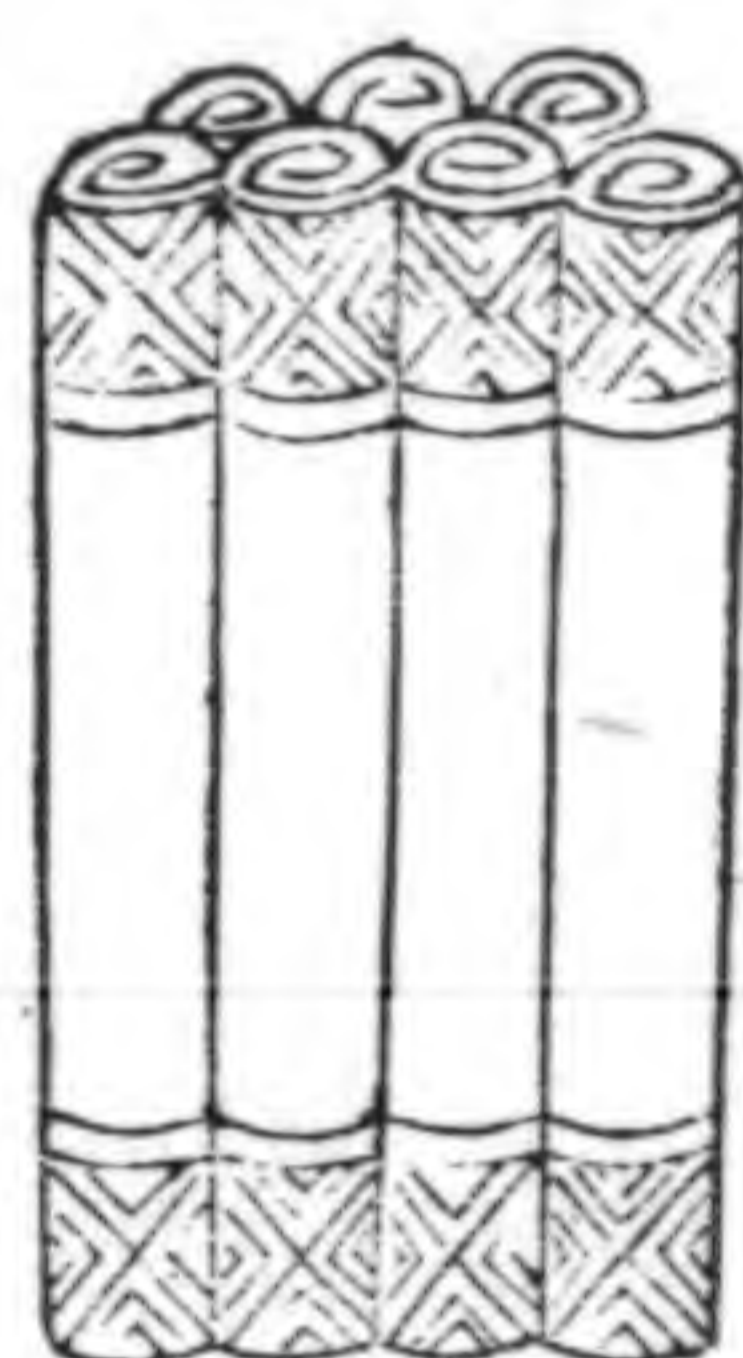

侯伯享天子用琮故合琮以錦享后亦用焉

璧以帛



侯伯享天子用璧故合璧以帛束帛加璧謂庭實也

琥以繡



子男享天子用琥故合琥以繡象陰以繡合之

璜以黼

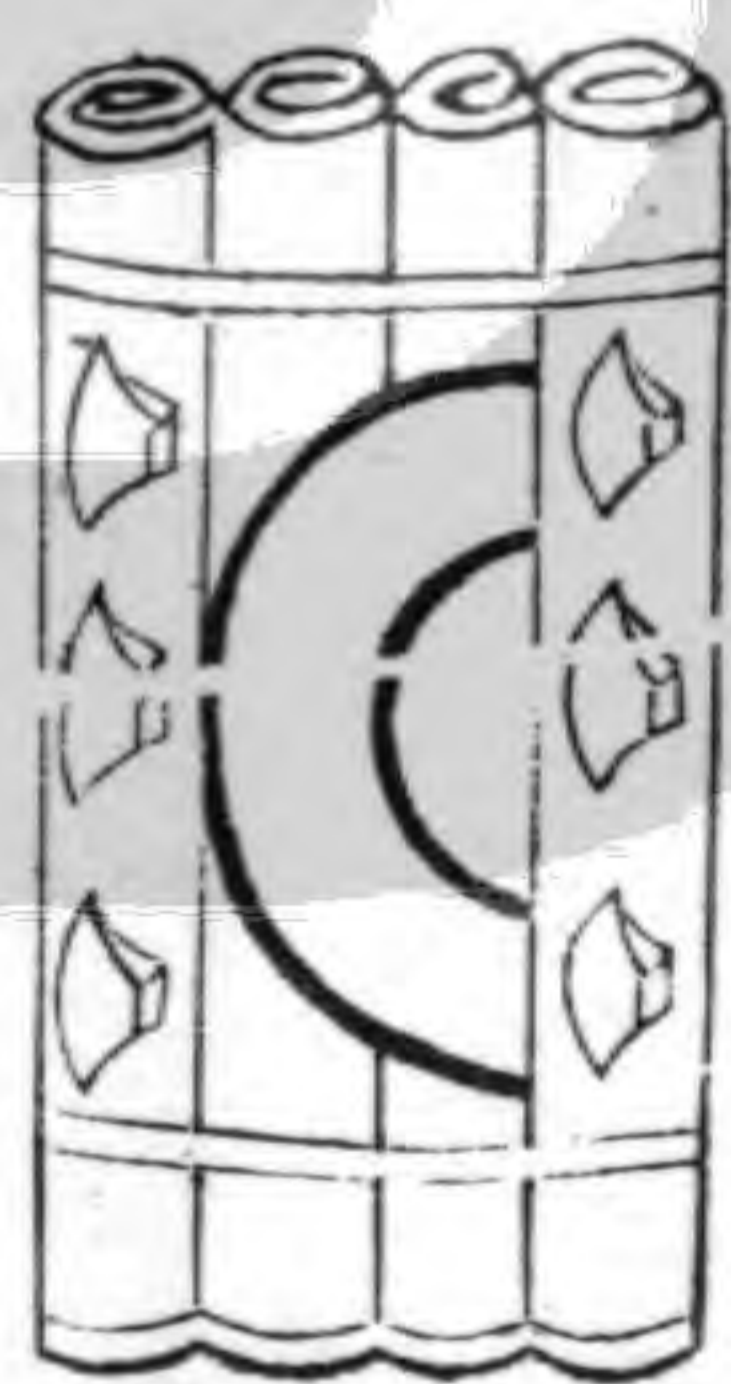

子男享天子用璜故合璜以黼北方所以黼合之

厭翟車制圖



巾車王后之五路其一厭翟后從王賓饗諸侯所
乘勒面績總翟雉羽也厭翟次其羽使相迫也勒
面謂如王龍勒之韋為馬面飾也五路皆有容蓋
容謂檐車總著馬勒直兩耳與兩鑣績畫文也蓋
如今小車蓋也

墨車制圖

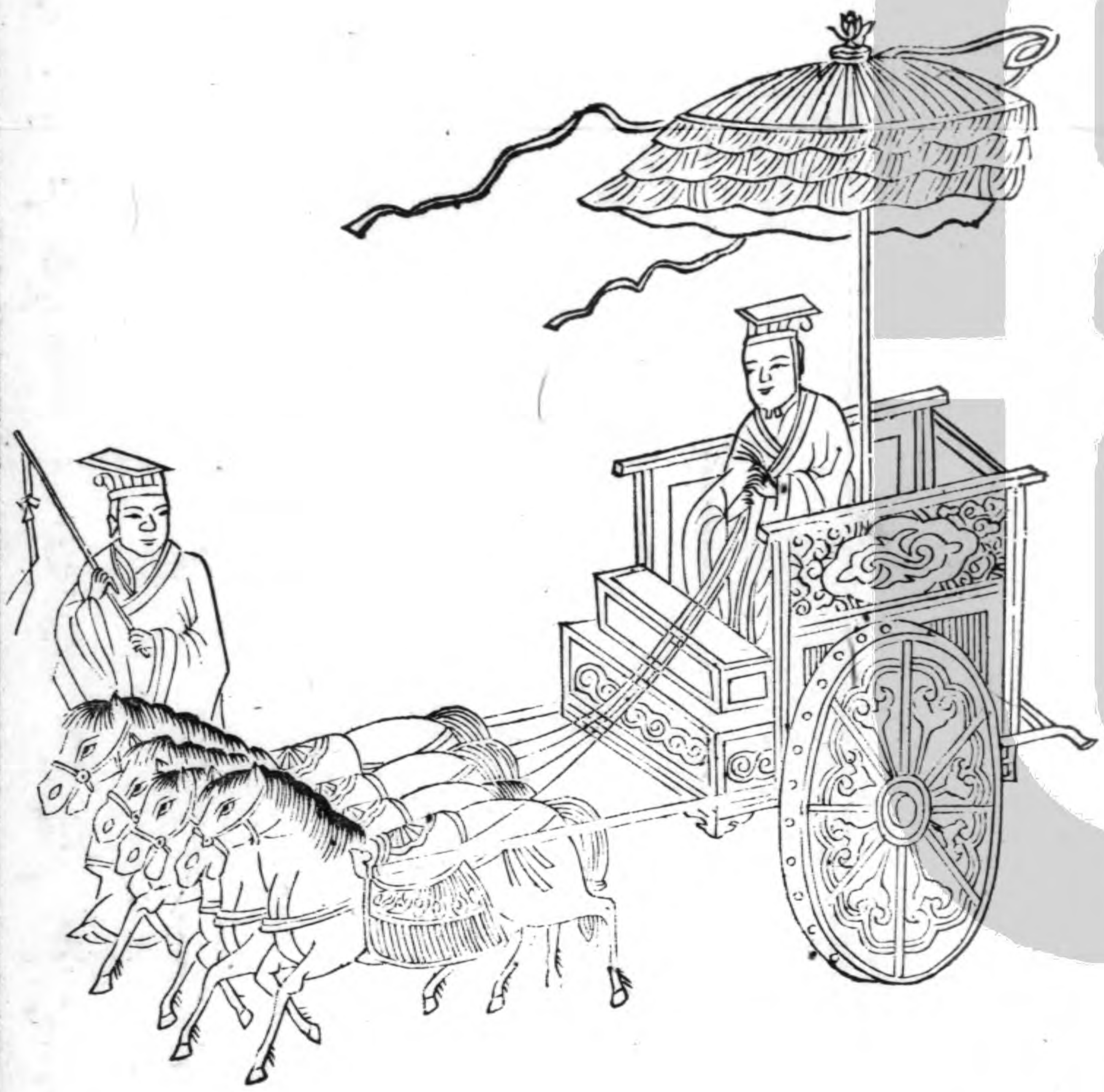

巾車服車五乘服車服事者之車其一大夫乘墨車墨車不畫也

九旗制圖

旗

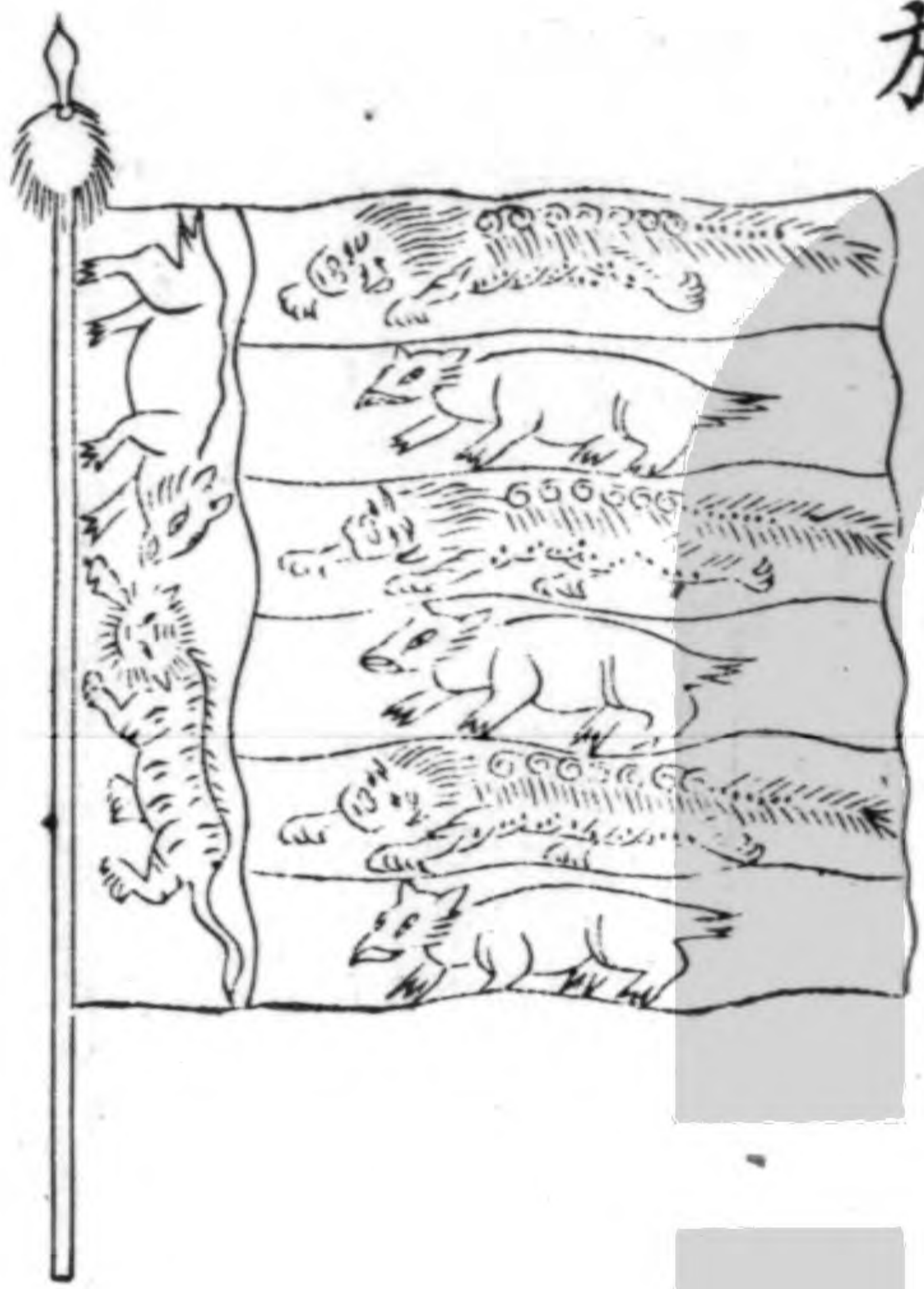

旒

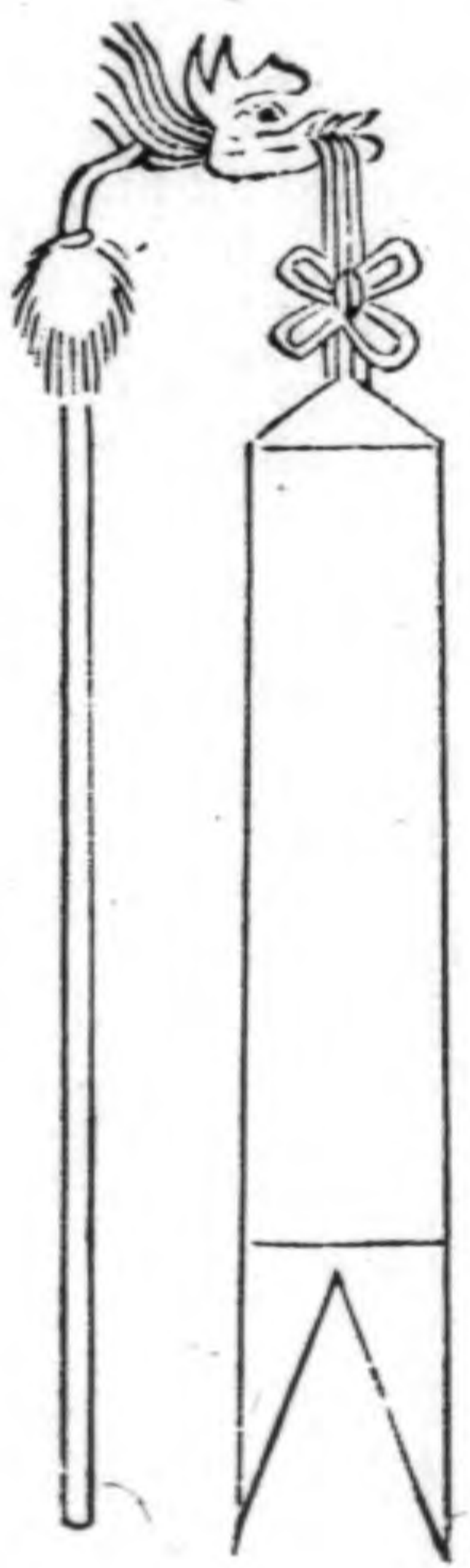

司常熊虎為旗師都建司常通帛為旒孤卿建旗考工記熊旗六游以旒注曰謂大赤從周正象伐熊以其毅虎以其色無飾巾車象路建大猛赤以朝異姓以封

旒



物

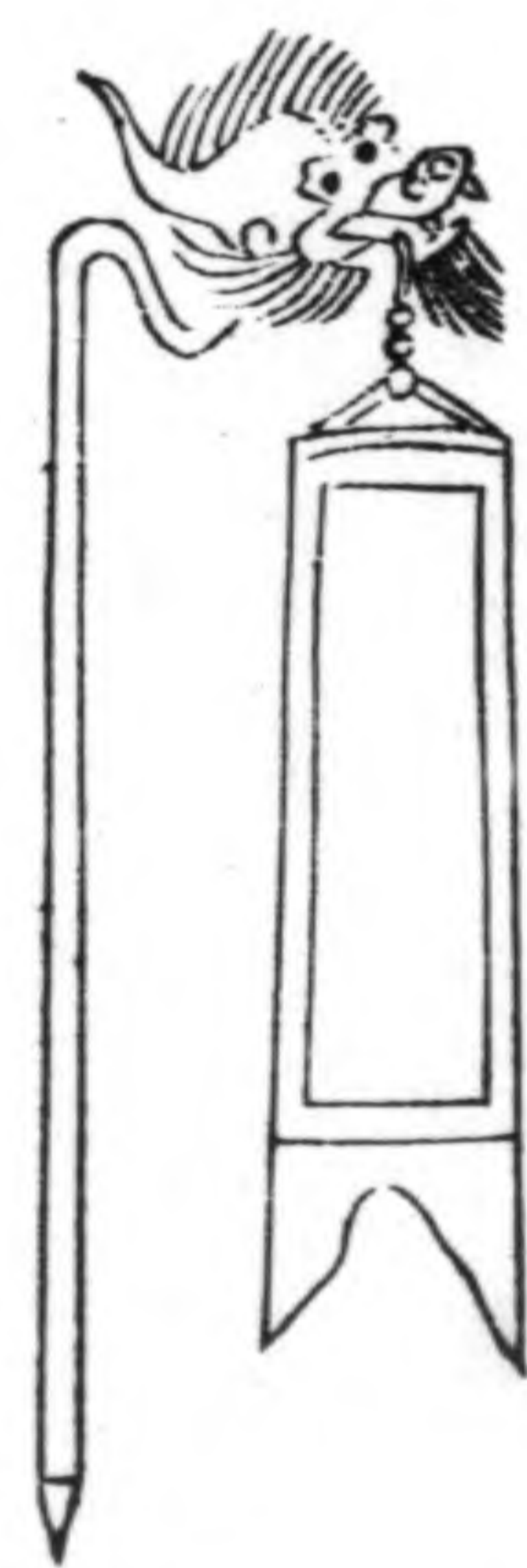

司常全羽為旒道車建
 旒注曰道車象路也王
 以朝夕燕出入全羽五
 色象其文德也

司常雜帛為物大夫士
 建物注曰以帛素飾其
 側白殷之色巾車革路
 建大白以即戎以封四
 衛

司常掌九旗之物名各有屬以待國事王氏曰旗
 之名則常旂旛物之屬旗之物則通帛雜帛之屬
 各有屬者謂自王以下各有屬建旗以便其屬視
 而從焉待國事謂師由賓祀之事
 旂旒旌旗已見
 詩經圖大常已

見尚書圖

六節圖

虎節



以金為節
鑄虎形使
山國用之

人節



以金為節
鑄人形使
土國用之

龍節



以金為節
鑄龍形使
澤國用之

符節



以竹為節
用於門關

管節



以竹為節
用於都鄙

旌節

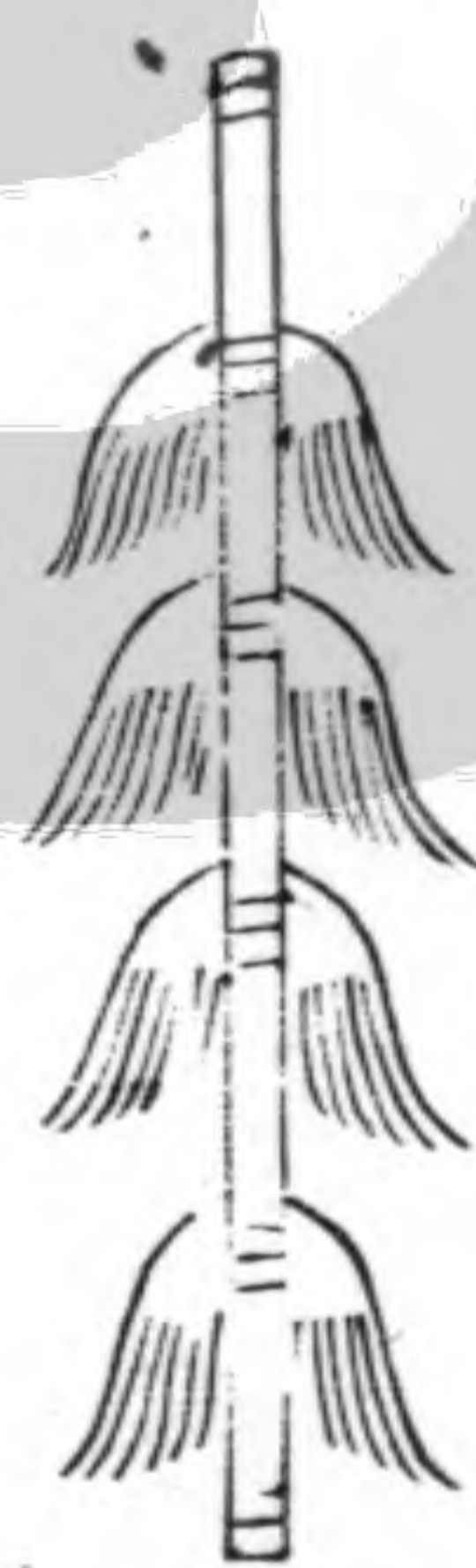

以竹為節
用於道路

註云此謂邦國之節也凡節有天子法式藏於國
虎人龍三者據諸侯使臣出聘所執旌符管三者
據在國所用

射侯制圖

虎侯

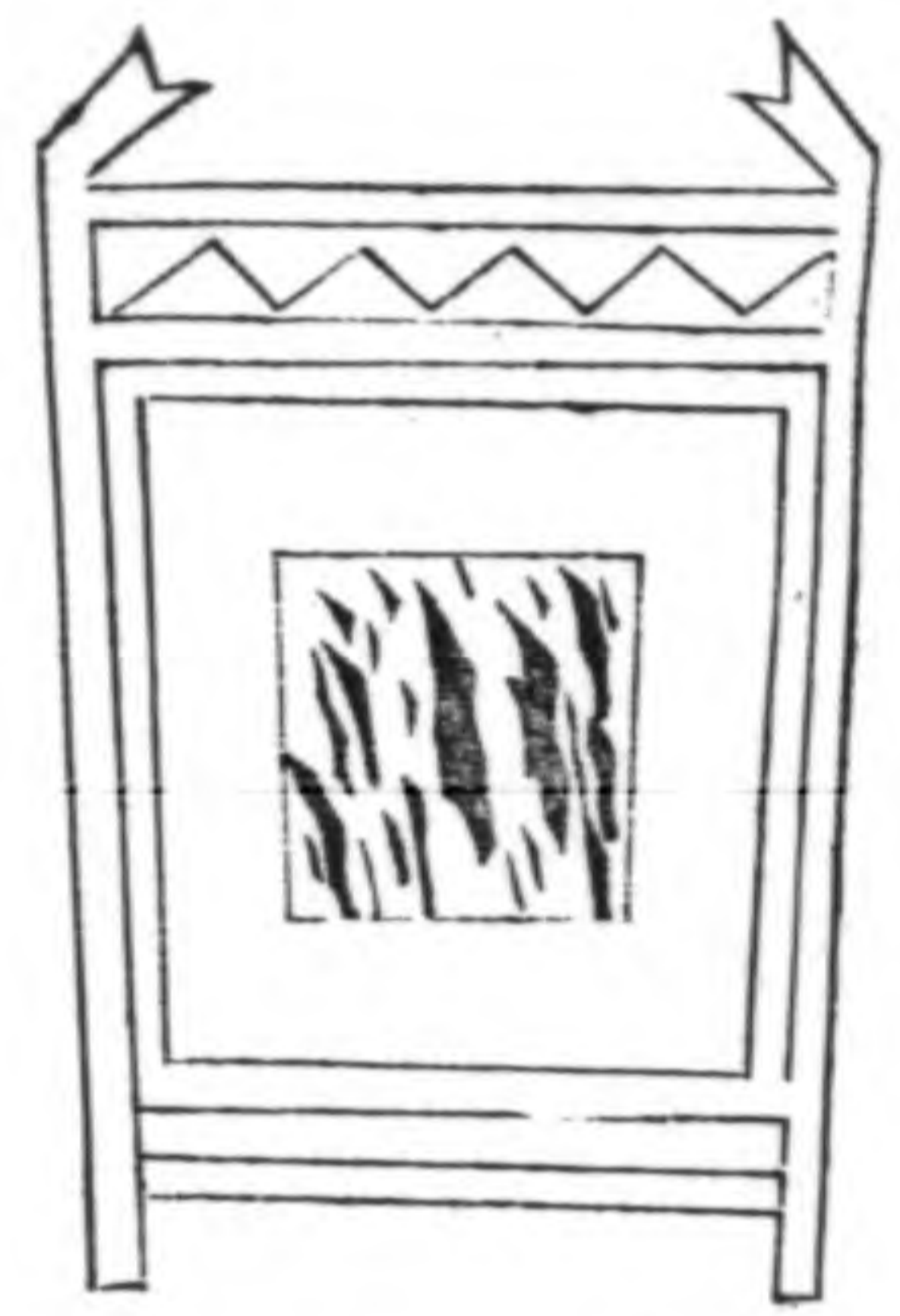

謂以虎皮飾其侯之側其鵠亦虎皮

大侯

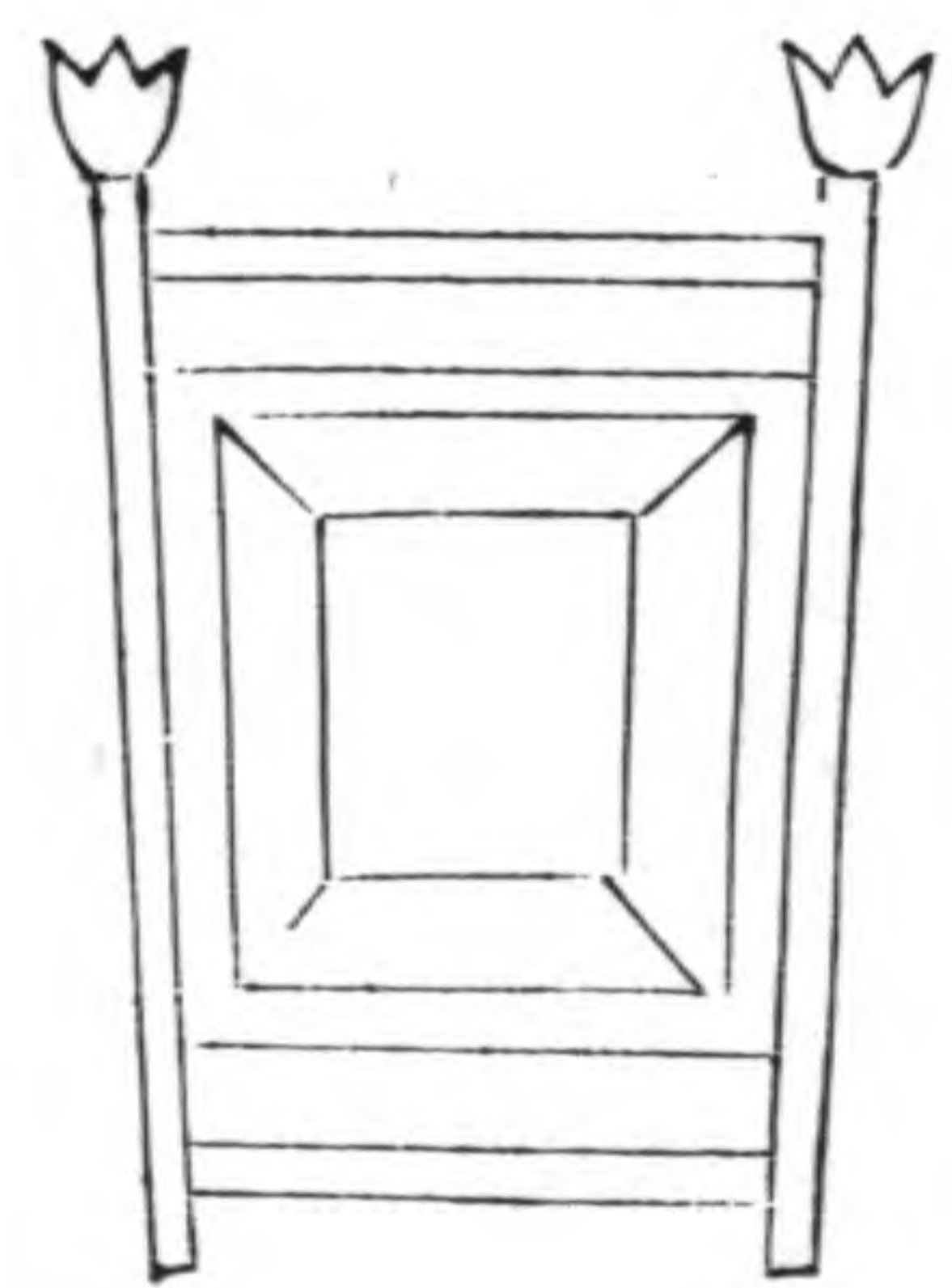

大侯九十弓畿外諸侯將祭先祖所射之侯

二正侯

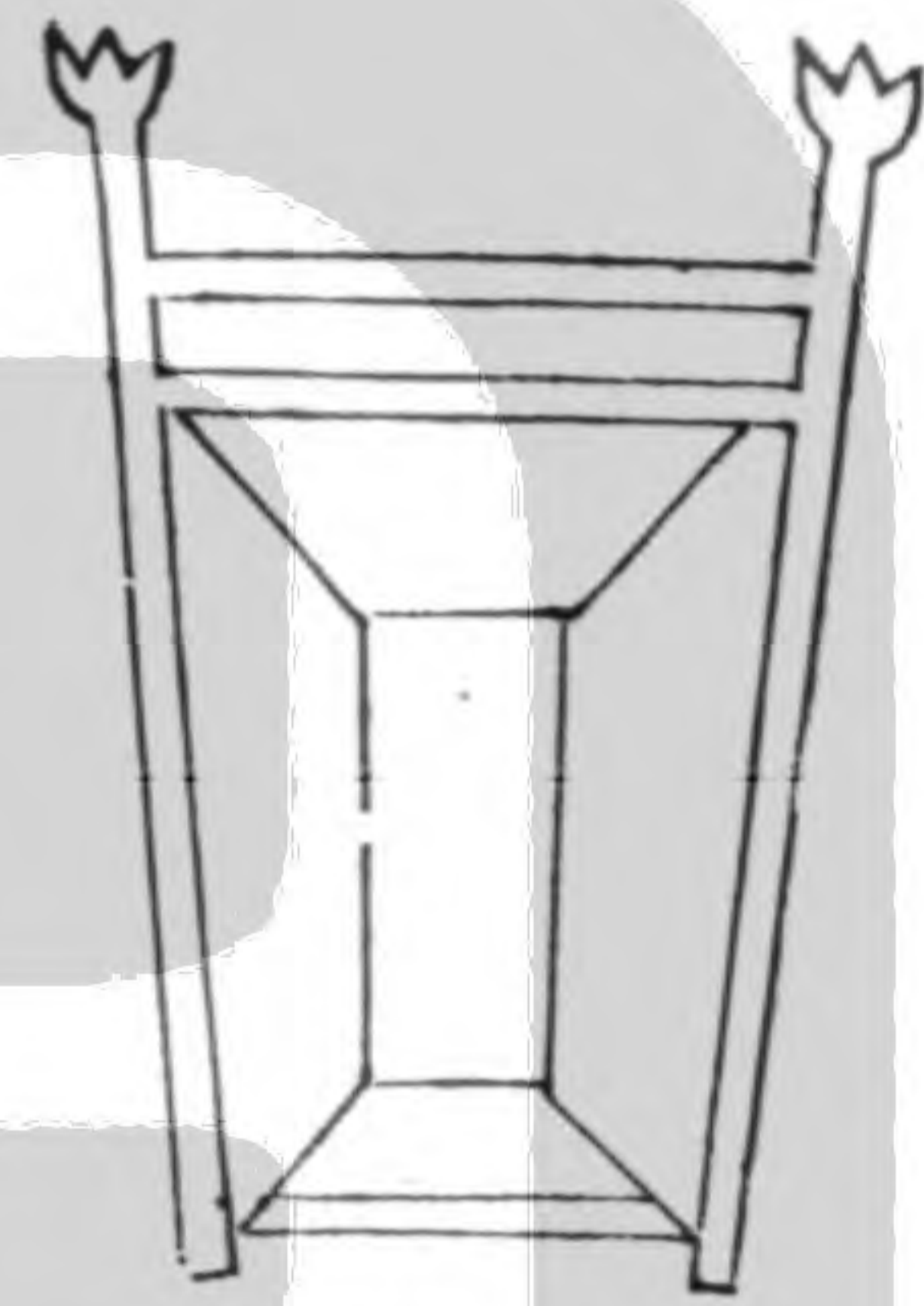

二正侯五十弓三分其侯正居一焉

熊侯

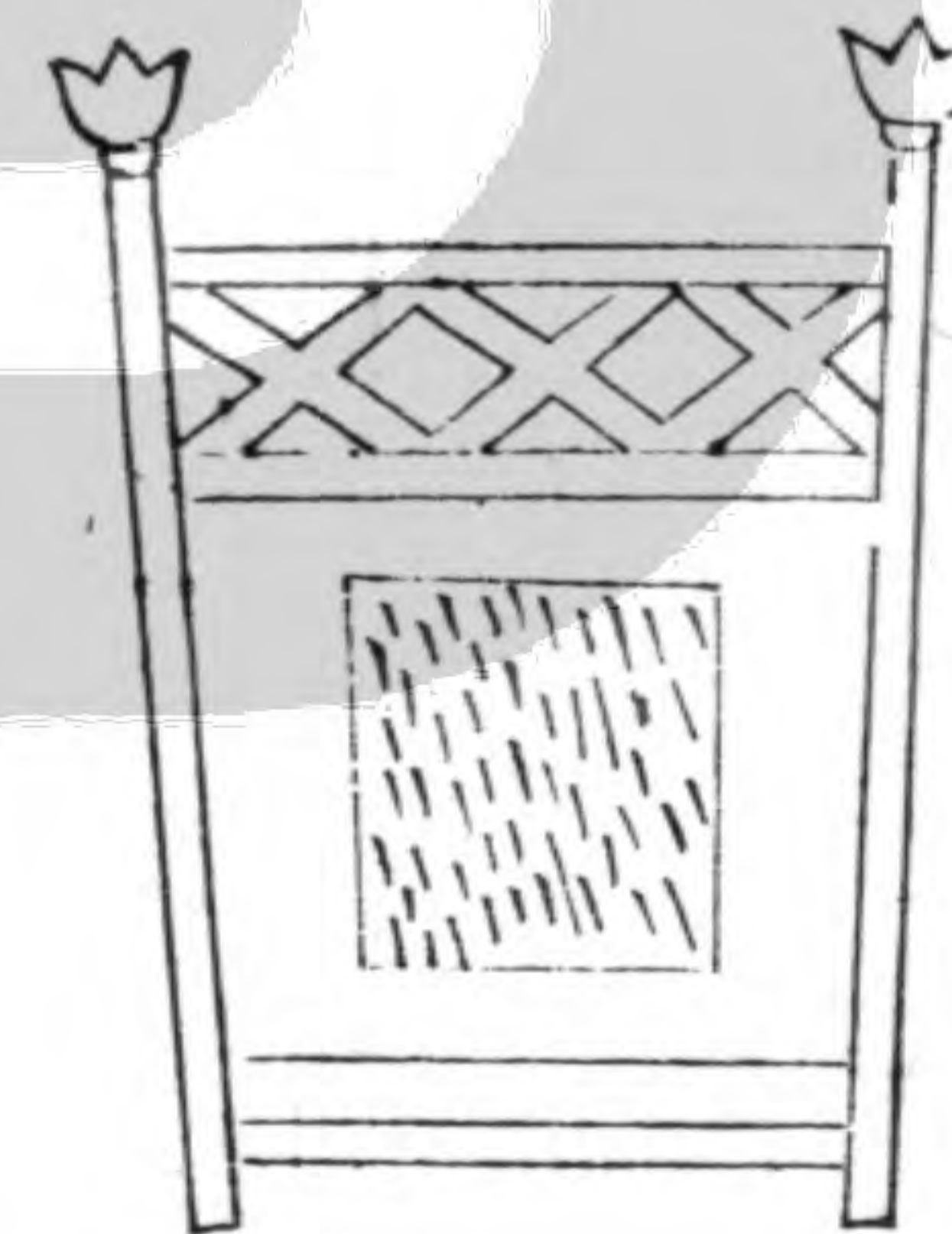

謂以熊皮飾其侯之側無以熊皮制其鵠

糝侯

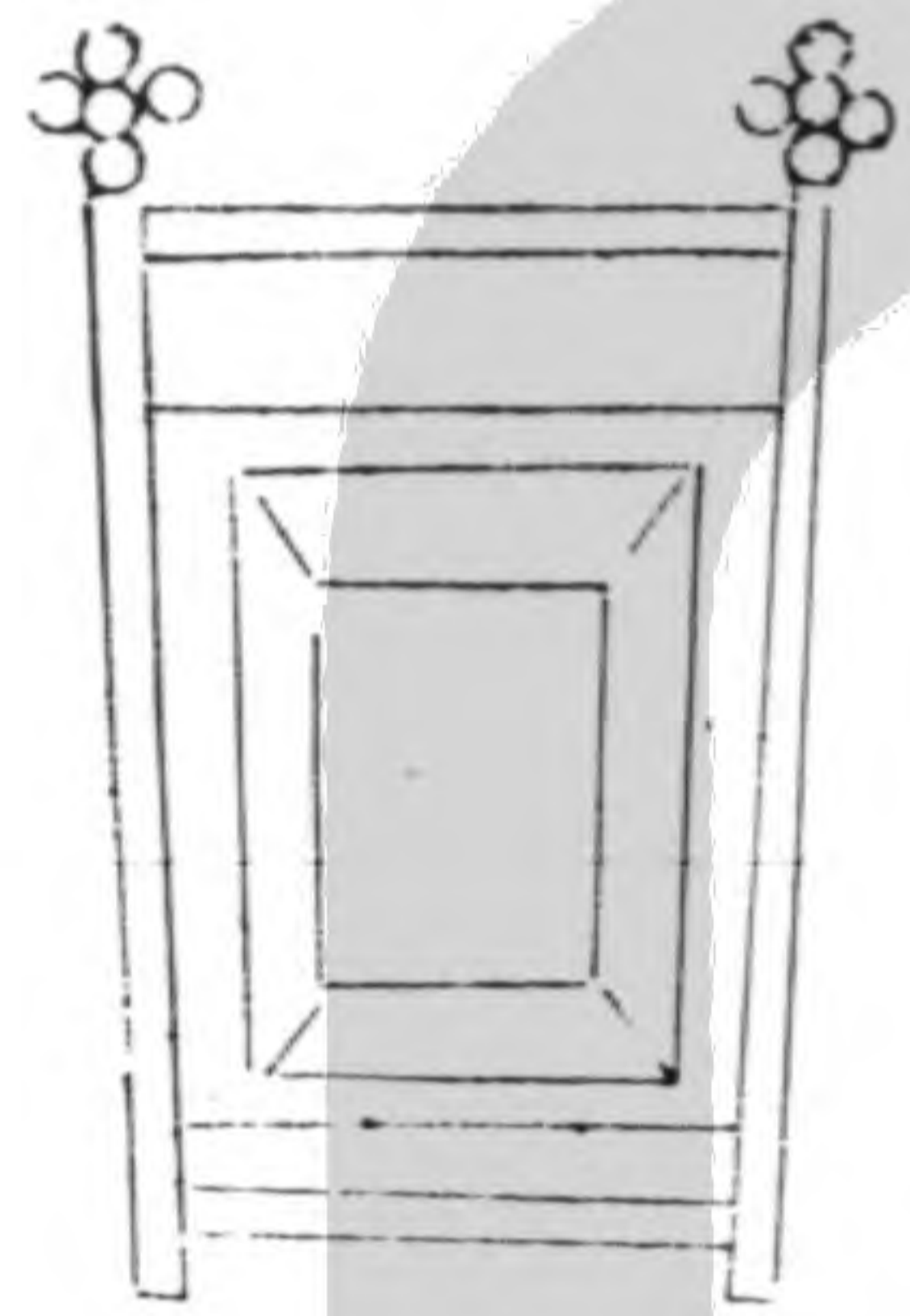

糝侯七十弓諸侯鄉大夫助祭所射之侯

獸侯熊首

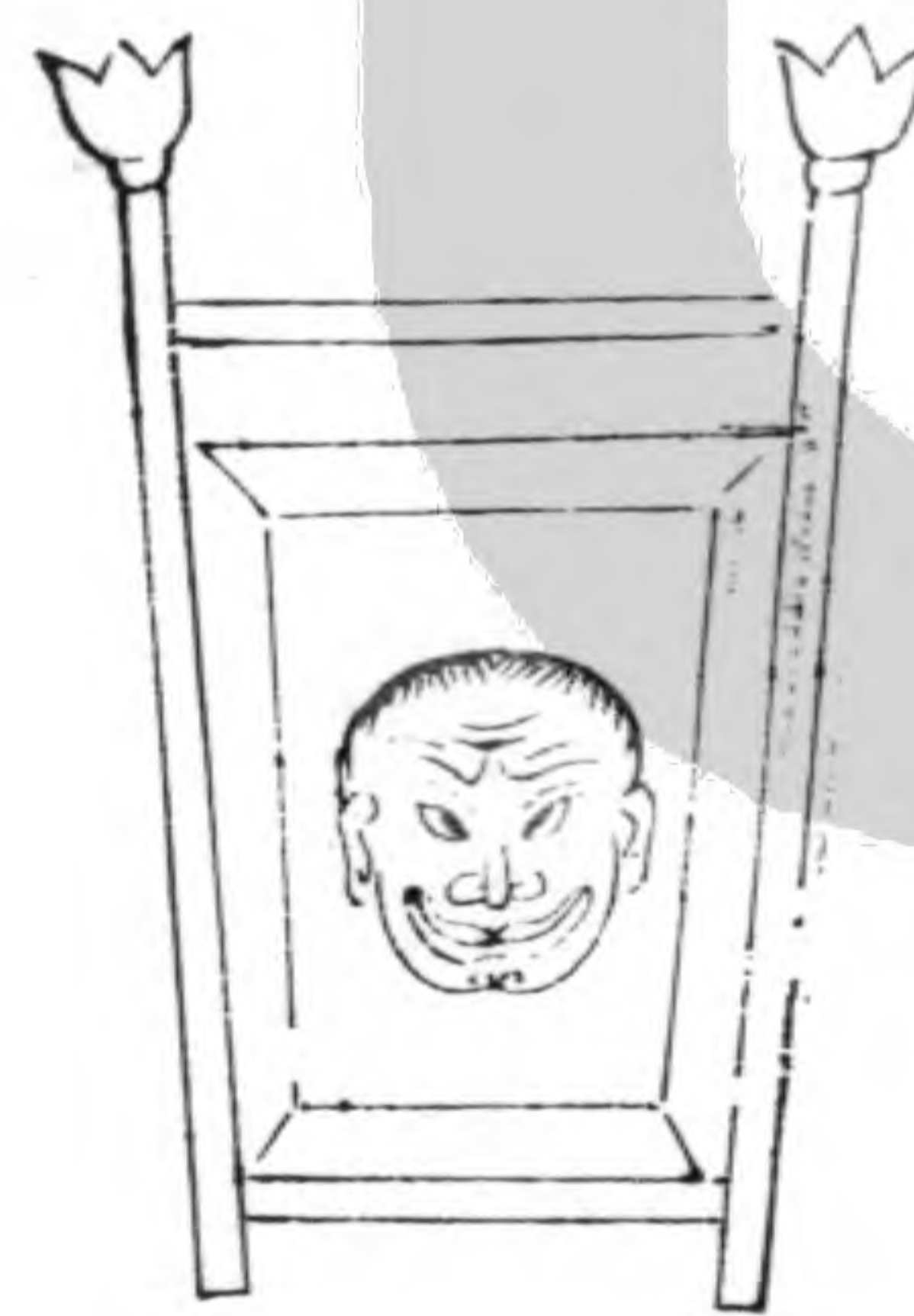

獸侯王以息燕畫獸為侯畫熊頭狀

豹侯

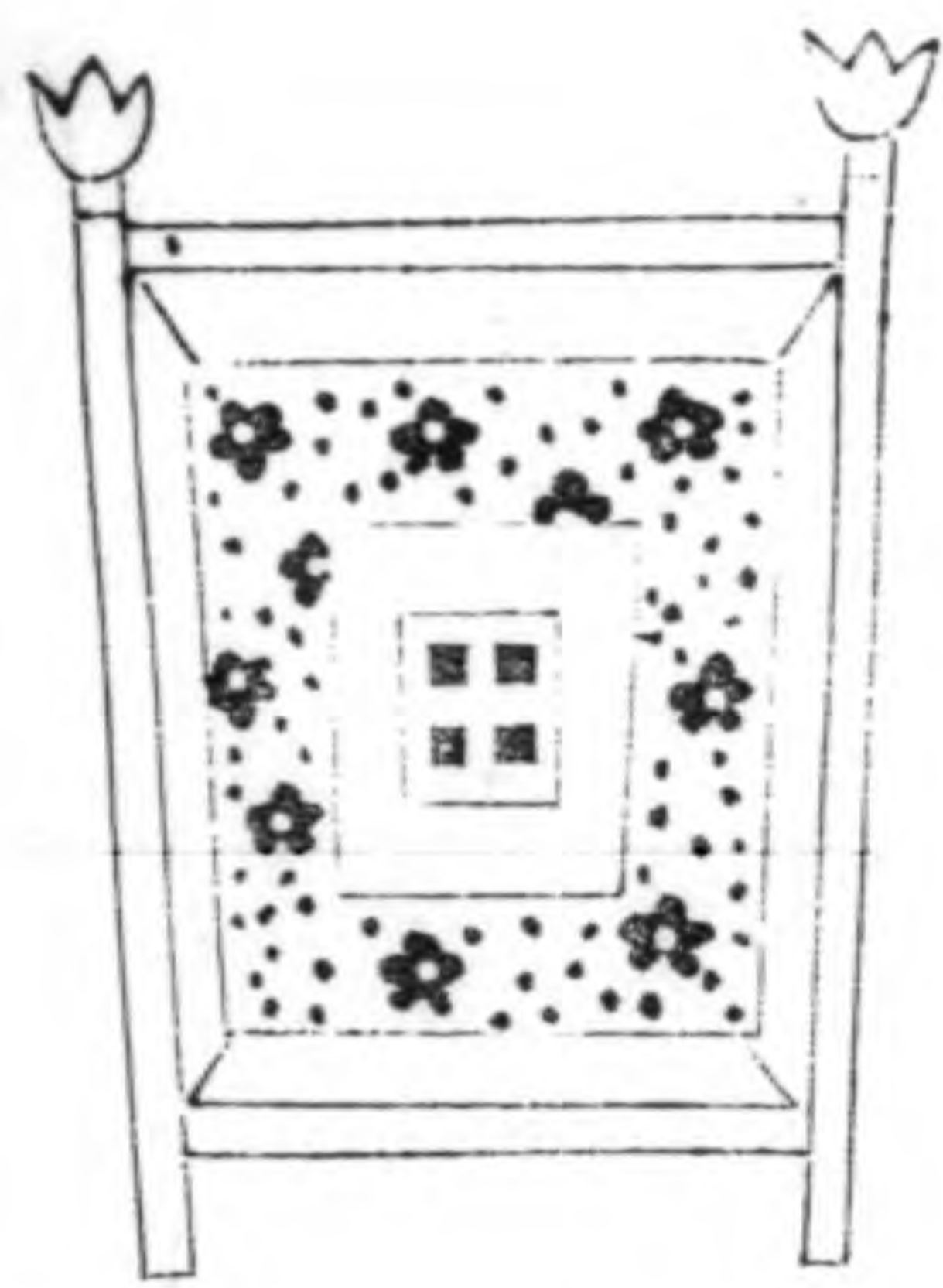

以豹皮飾侯側無以豹皮方制其鵠

豸侯

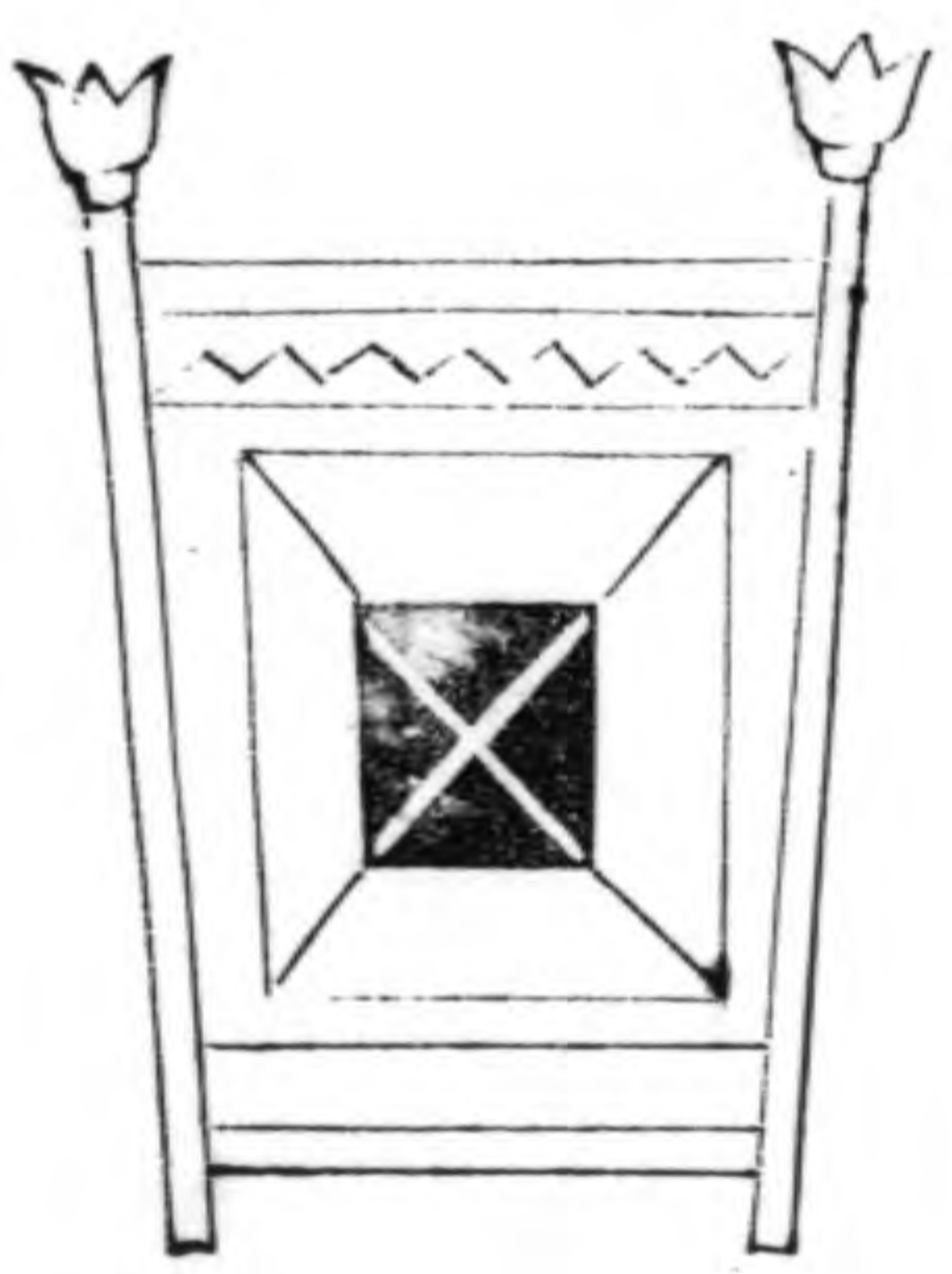

豸侯五十弓諸侯之士助祭所射之侯

獸侯麋首

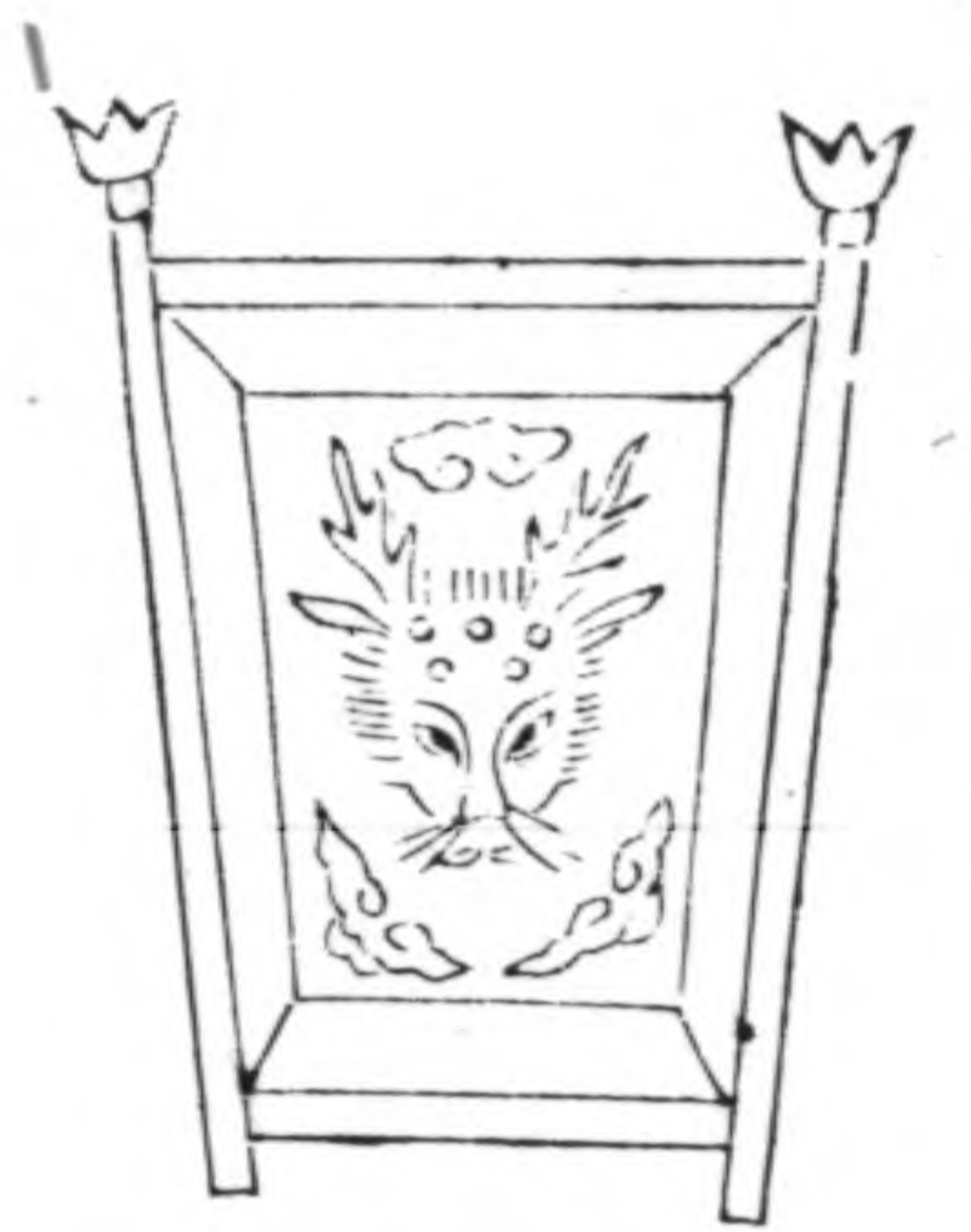

王燕勞之
侯諸侯射
亦畫雲氣
飾其側

熊侯

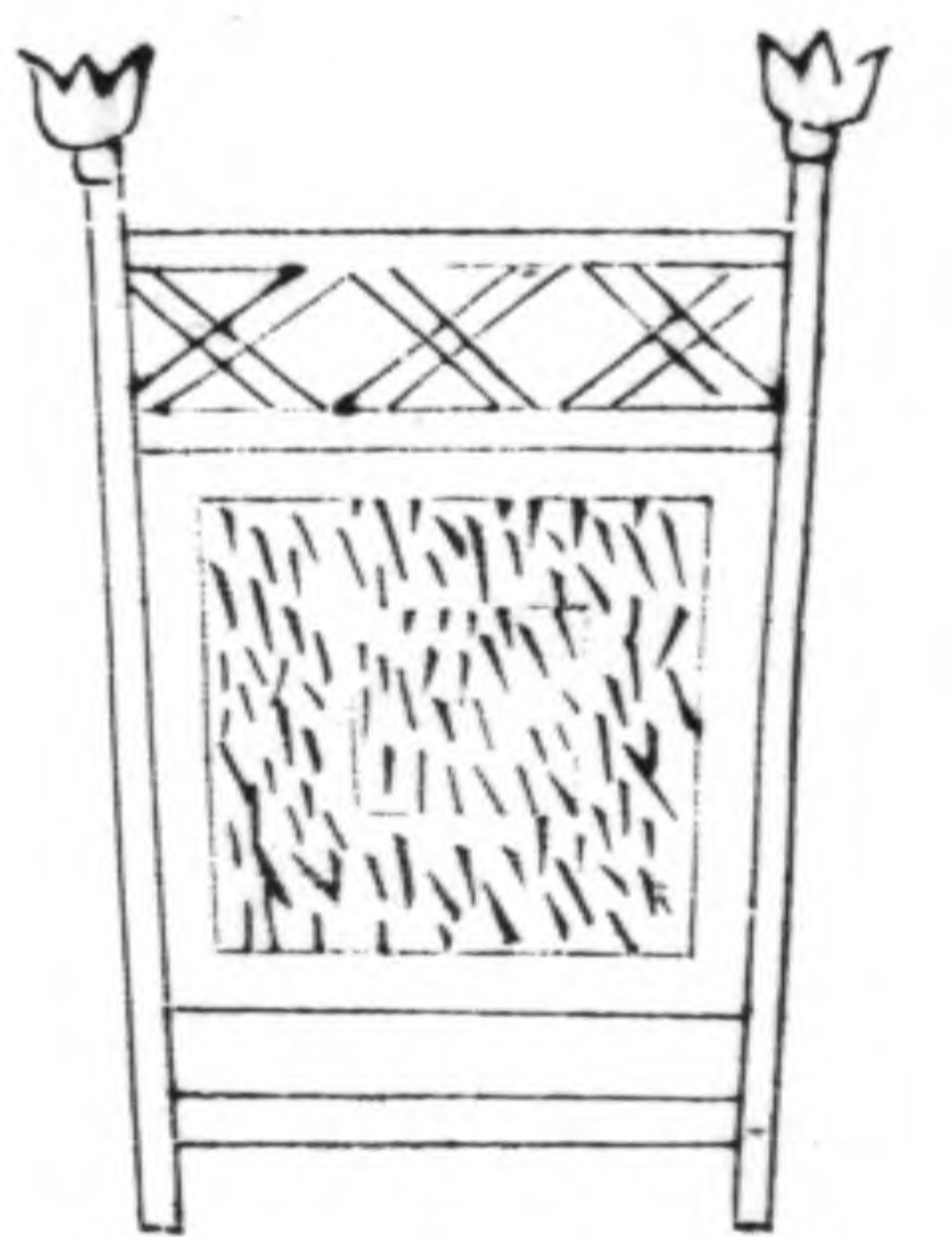

諸侯自射
之侯其侯
道鵠與王
熊侯同

五正侯

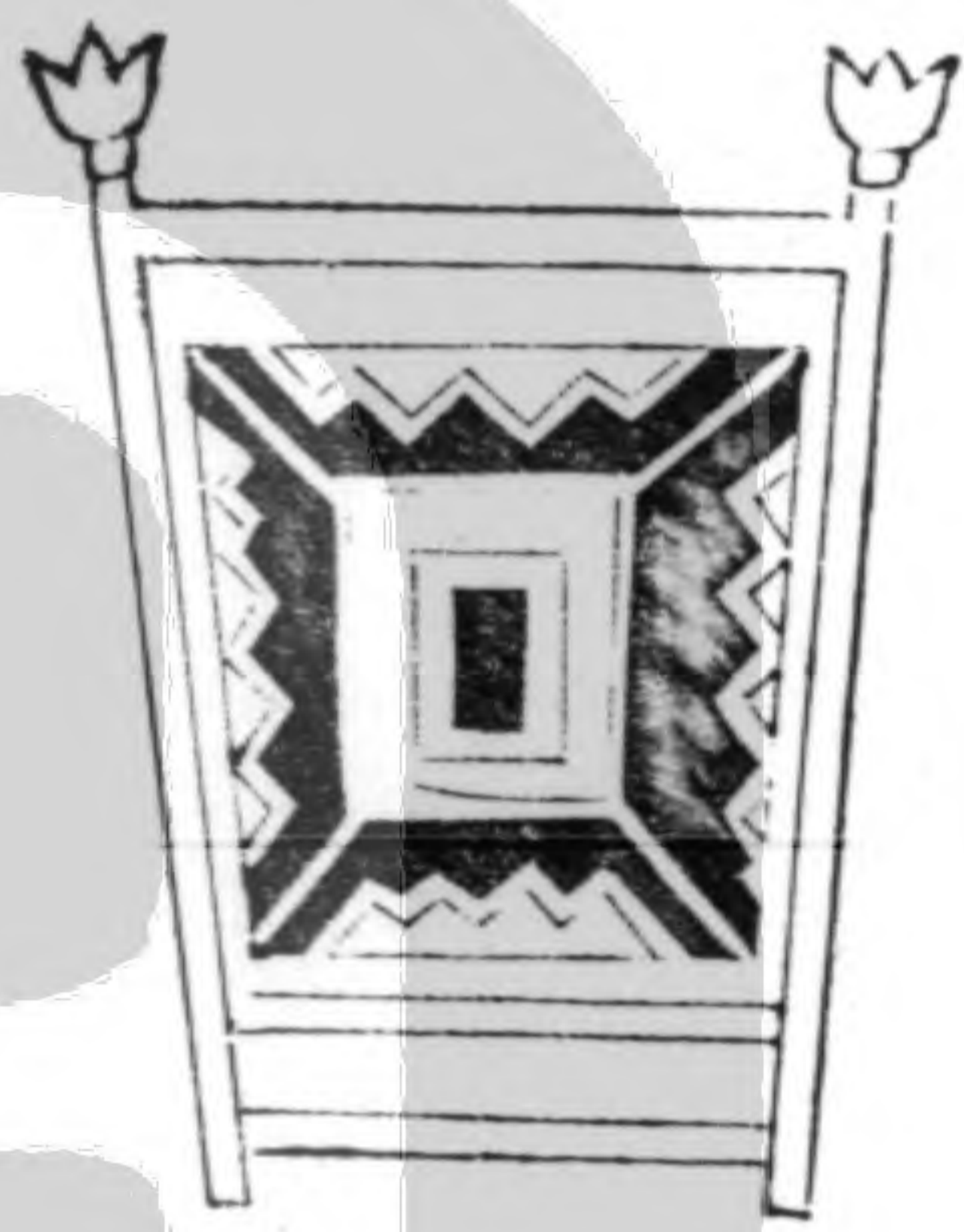

五正侯九
十弓三分
其侯正居
一焉

獸侯虎豹首



王燕射則
御大夫射
畫虎豹頭
之狀

麋侯

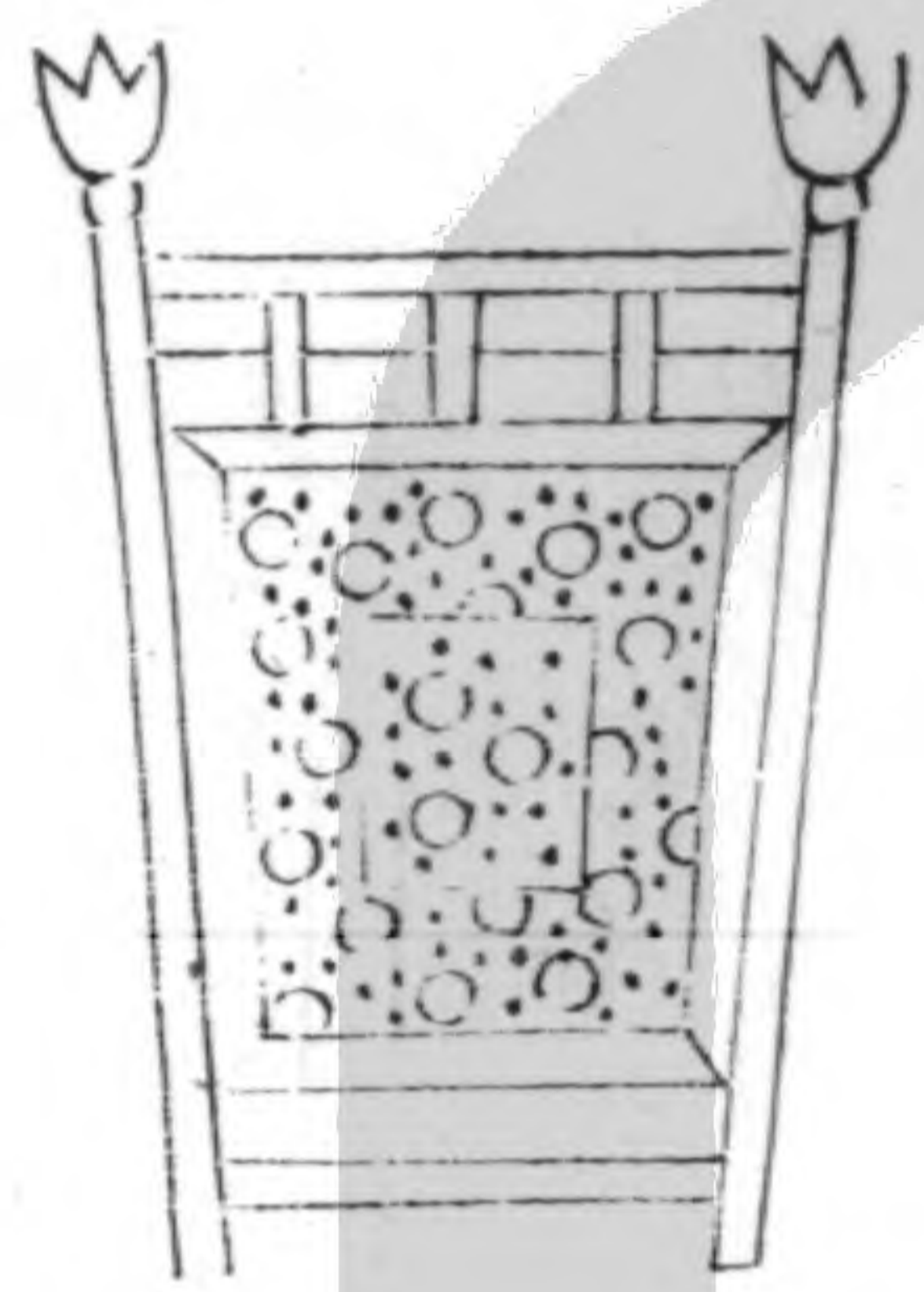

以麋皮飾
侯側又以
麋皮方制
其鵠

三正侯

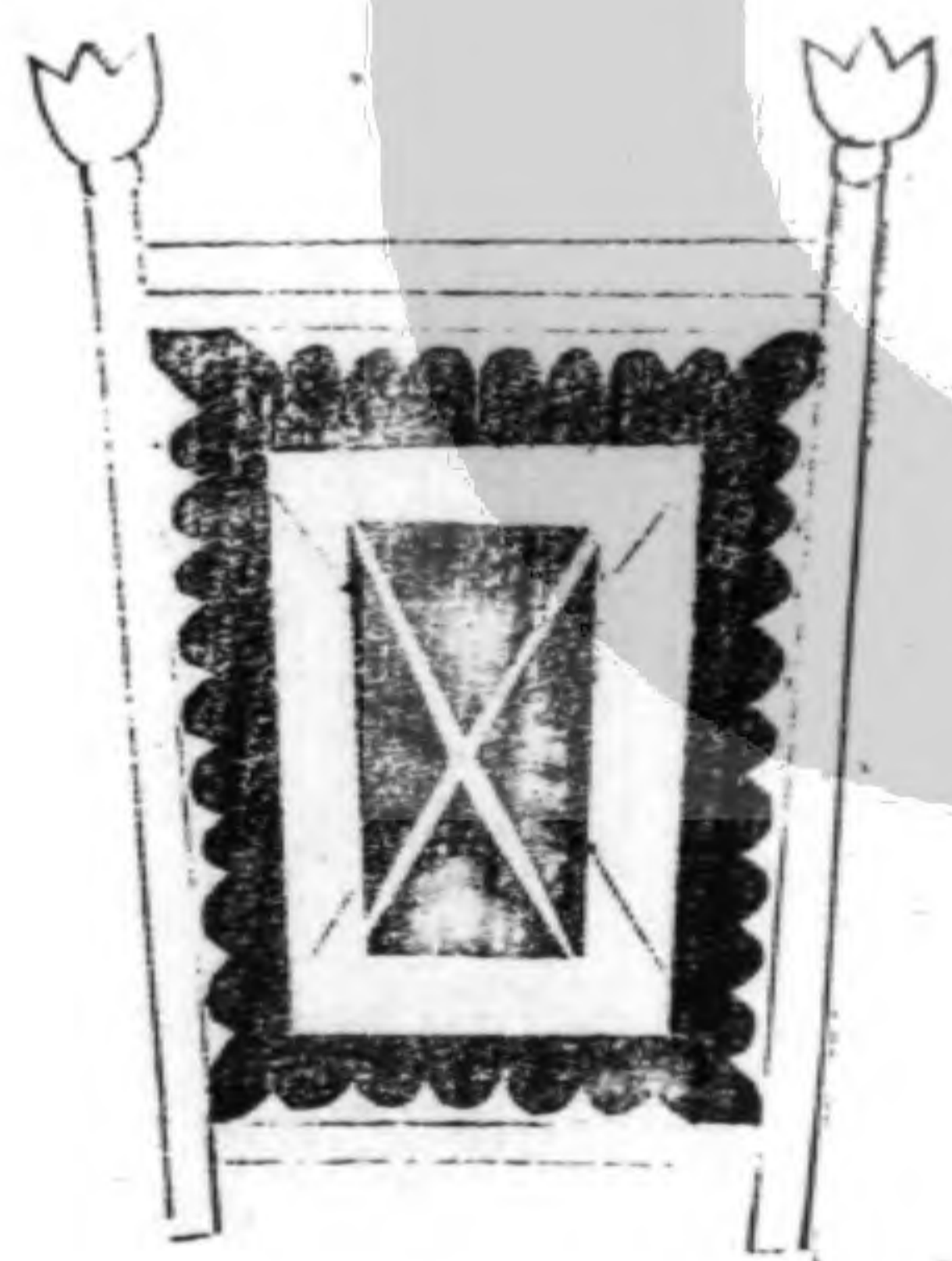

三正侯七
十弓三分
其侯正居
一焉

獸侯麋豕首



王燕射士
射鹿豕首
布侯侯道
五十弓

按射義疏凡天子諸侯及卿大夫射禮有三一為大射是將祭擇士之射二為賓射諸侯來朝天子入而與之射也或諸侯相朝而與之射三為燕射謂燕息而與之射其天子諸侯大夫三射皆具惟士無大射又按詩行葦箋云周之先王將養老先與羣臣行射禮擇其可與者以為賓疏禮稱將祭而射謂之大射養老與祭相類射以擇賓則六為大射賓射在朝而射以娛賓燕射因燕而射以為樂皆無擇士之義

擯禮圖

在主君之東南西南面每擯相去各三丈六尺

上擯

次擯

末擯

賓主各有副賓副曰介主副曰擯

主君西南面

末擯與末介相去亦三丈六尺

賓北面

介每介相去亦三丈六尺
 介每介相去亦三丈六尺
 介每介相去亦三丈六尺
 介每介相去亦三丈六尺

周禮秋官行人上公九介侯伯七介子男五介各隨其命數賓次于大門之外主人使擯者出而請事卿為上擯大夫為承擯士為紹擯主國之君公則擯者五人侯伯四人子男三人各用其命數之半下于賓以示謙也傳命之制賓立于庫門之外主君出接命上擯請問來故上擯受君命而遞傳之末擯末擯傳之末介末介遞傳之賓賓命上介復命復以次傳之上擯而達于主君然後主君迎賓以入

龜人圖

龜

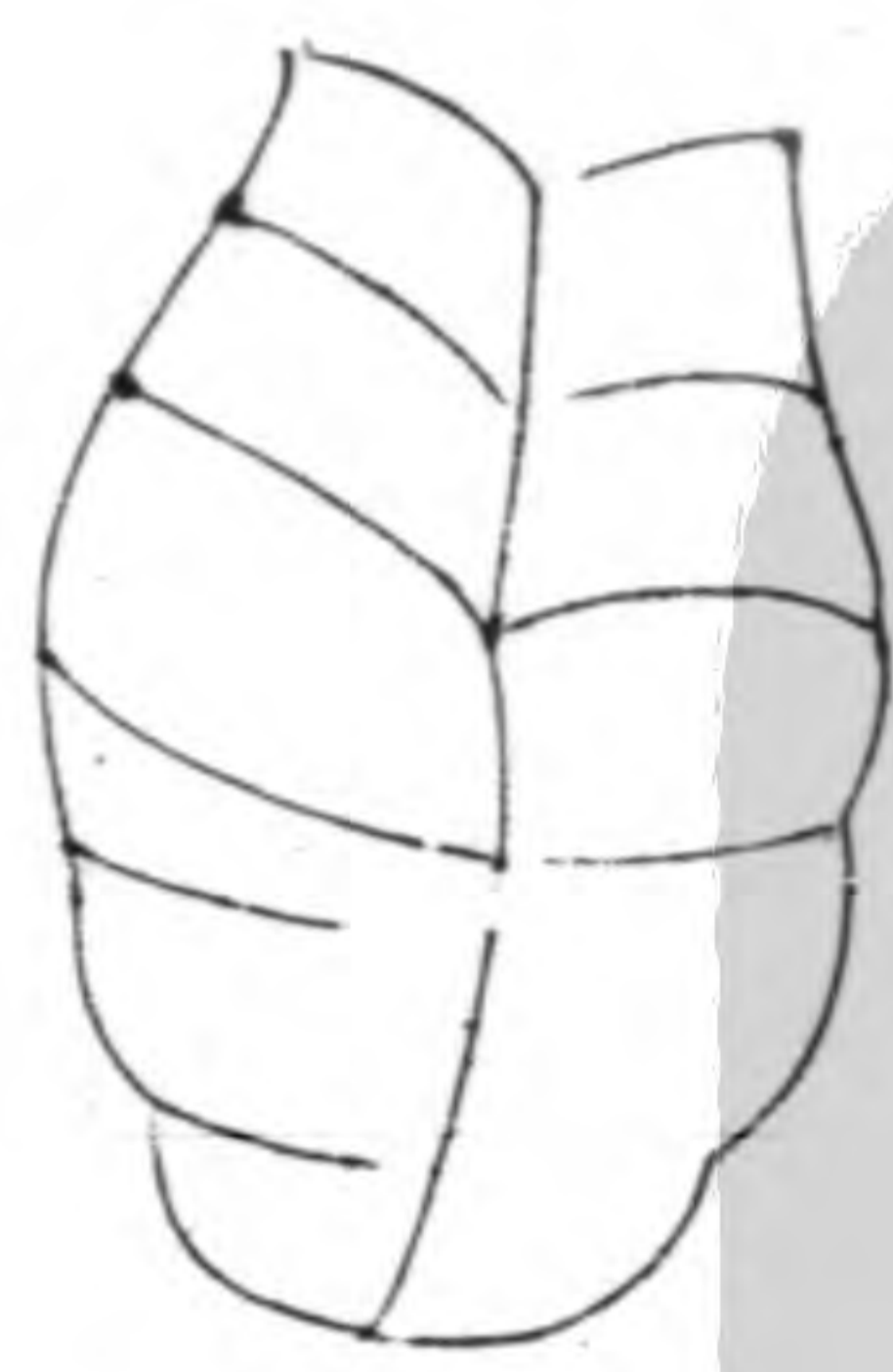

焦



楚焯



龜人取龜用秋時攻龜用春時春灼後左夏灼前左秋灼前右冬灼後右

焦存火之炬灼龜之時用燃楚焯也

楚焯者謂荆為楚用之焯龜開兆

筮人圖

著

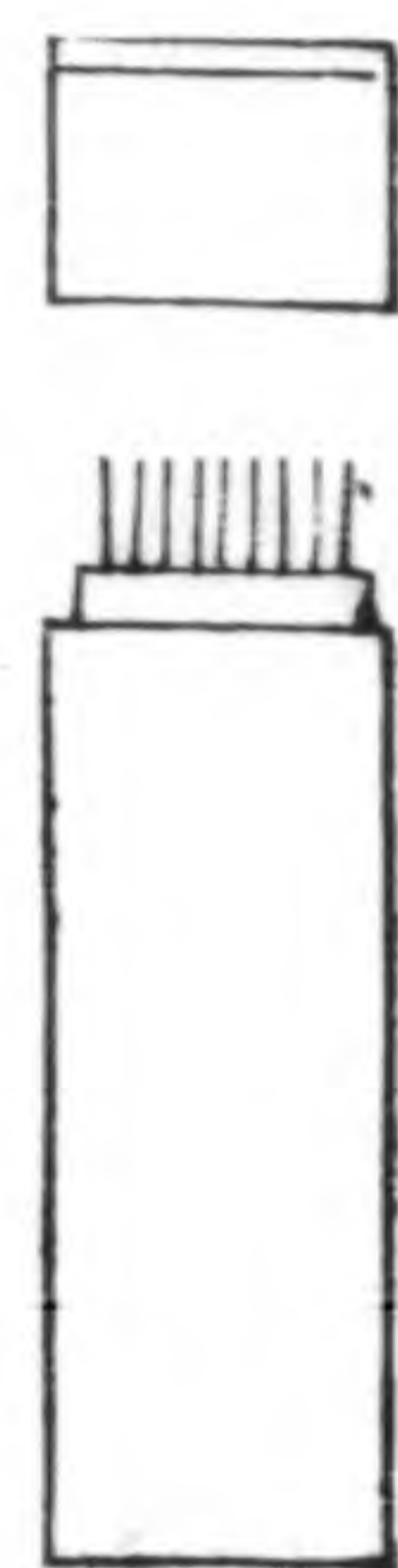

著以為筮策贖
歲筮之器

畫爻木



古者用木
畫地記爻
今以錢

卦板



所筮六爻俱
了卦體得成
更以方板畫
卦體示人也

馮相太歲圖

馮相氏掌十有二歲歲謂太歲歲星與日同次之
月斗所建之辰也歲星為陽右行於天太歲為陰





右行于地十二歲而小周與日常應太歲月建以
 見之三禮義宗云歲星者東方蒼龍之宿五星
 之神法五周於地亦十
 二歲

周禮六六

土圭測日圖

太西多陰日中
 去西千里一表

而日景尺五寸

夏至日晝
 漏半

陽城立中表

就中表取一尺五寸表為中

太北遠日多寒
 去北千里一表
 景不過尺五寸

而日景尺五寸

去東千里一表

太東多風日昃

土圭長尺五寸夏至日午樹表八尺以圭量日景
 尺五寸合者其地即天地之中也測土深謂地深
 不可見以土圭正日景測之蓋地與星辰四游升
 降進退不越三萬里夏至地東南游萬五千里下
 降亦然秋分復正冬至西北游亦萬五千里上升
 亦然春分復正大約日景每千里差一寸景尺五
 寸是地南戴日下一萬五千里為地中心與天心
 相對也日南四者申明一尺五寸得中之善

水地法圖

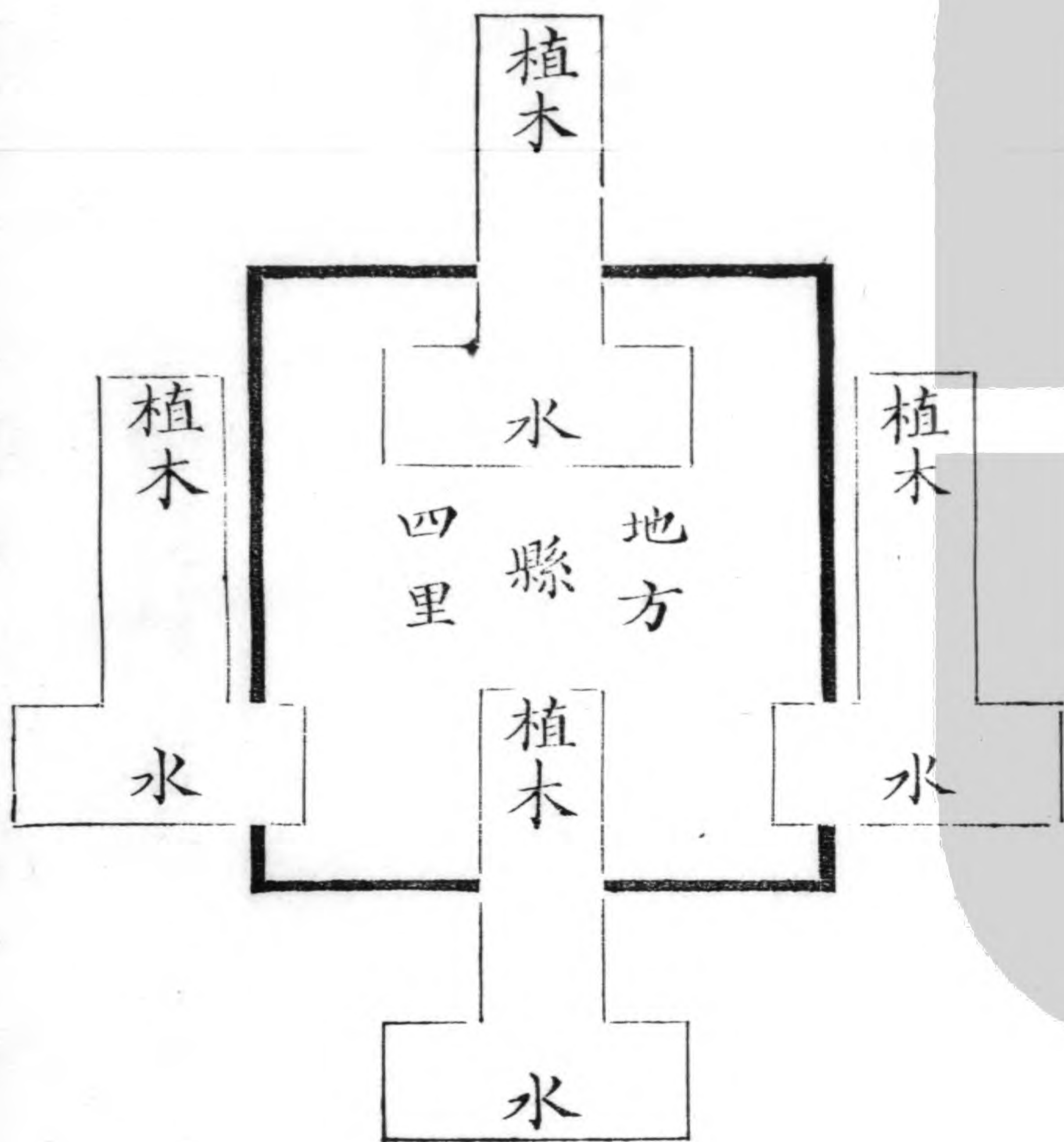

匠人建國水地以縣謂欲置國城先當以水平地
於四角立四柱於四柱畔懸繩以正柱以水望其
高下即知地之高下然後平高就下地乃平也

周禮圖叅訂

六官目典婦功

吳本功
譌切

司徒

司譌
師

簠

中脫
一畫

庾人

譌

瘦司甲

甲譌
申

家司馬

脫

赤友氏

友譌
友

王宮制圖宗廟昭穆亦譌東西向正之

治朝燕朝外朝並增注

次圖廡圖增注

司几筵吳本注畧今增

鄉遂采地圖經緯內賞宅士賈官牛牧田牛譌邦

縣三十八萬井

脫萬
字

四都為同圖注積萬井九萬夫夫譌

六鄉圖中士一人二譌比長下士二人

六遂圖注十二同十二萬井二譌

九服圖注增王氏及周索戎索三條

職方九州豫州滎洛舊本滎譌充浸盧維從錐

指作雷澤昭餘祈祈譌

朝貢圖所貢祀嬪等物各增注

圜邱樂圖注黃鐘為角脫為太簇下生南呂下譌

天神皆降下脫可得而五字

方澤樂圖注太簇為角下生南呂下譌南呂上生

姑洗脫上夏日至於方澤中奏之方字倒

宗廟樂圖注南呂為天宮之陽陽宮二字倒用

分舞圖舞大磬同吳本磬譌

冕旒弁服及后首飾服制並据三禮圖改繪

筍虞注引考工記工譌鐘虞鐘譌兩端有璧兩

有

罇注細鈞有鐘無罇罇譌

鼓人四金注推頭推頭譌

樂器牘注春牘春為等注三十六簧簧為黃應注髮

畫之髮為雅注羊皮鞞之鞞从韋旁頃注瞽矇矇為蒙

祭器制圖壘注雲雷之形為山爵坫為玉爵注

改房俎注改簠簋注增

望人制圖概注朱帶絡腹脫帶如蜃尊尊為大壘

注祭祀社壇壇為稷

輪人為蓋按三禮圖如今常用雨蓋但週圍增一

淺簷耳注以含達常含為

馮相太歲注增三禮義宗一條

射侯制圖注射於榭用鹿中鹿為虎

龜人注取龜用春時脫時

土圭測日增注

水地法增注

