



EX BIBLIOTHECA



CAR. I. TABORIS.



22101881638





60/00

Great Exhibition of the Works of Industry of all Nations,
1851.

OFFICIAL
DESCRIPTIVE AND ILLUSTRATED
CATALOGUE.

By Authority
of the



Royal
Commission.

IN THREE VOLUMES.

VOL. II.

SECTION III.—MANUFACTURES, CLASSES 11 TO 29.

SECTION IV.—FINE ARTS, CLASS 30.

COLONIES.

LONDON:

SPICER BROTHERS, WHOLESALE STATIONERS; W. CLOWES AND SONS, PRINTERS;

CONTRACTORS TO THE ROYAL COMMISSION,

29 NEW BRIDGE STREET, BLACKFRIARS, AND AT THE EXHIBITION BUILDING.

M DCCCL.

1143901

LONDON · PRINTED BY WILLIAM CLOWES AND SONS,
PRINTERS TO THE ROYAL COMMISSION,
STAMFORD STREET AND CHARING CROSS.

WELLCOME INSTITUTE LIBRARY	
Coll.	walshomec
Call	
No.	Q3
	1851
	G780

CONTENTS OF VOLUME THE SECOND.

UNITED KINGDOM.—CLASSES 11 to 30.

	Page		Page
SECT. III.—MANUFACTURES:—CLASSES 11 to 29.			
11. Cotton	479	24. Glass	697
12 & 15. Woollen and Worsted	485	25. China, Porcelain, Earthenware, &c.	709
13. Silk Velvet and	503	26. Furniture, Upholstery, Paper Hangings, Decorative Ceilings, Papier Maché, and Japanned Goods	729
14. Flax and Hemp	509	27. Manufactures in Mineral Substances, for Building or Decoration	763
16. Leather, Saddlery and Harness, Boots and Shoes, Skins, Fur, and Hair	517	28. Manufactures from Animal and Vegetable Substances, not being Woven or Felted	777
17. Paper, Printing, and Bookbinding	537	29. Miscellaneous Manufactures and Small Wares	789
18. Woven, Felted, and Laid Fabrics, Dyed and Printed (including Designs)	553		
19. Tapestry, Carpets, Floor-cloths, Lace, and Embroidery	559	SECT. IV.—FINE ARTS:—CLASS 30.	
20. Articles of Clothing for immediate, personal, or domestic use	575	30. Sculpture, Models, and Plastic Art, Mosaics, Enamels, &c..	819
21. Cutlery, Edge and Hand Tools	591		
22. General Hardware, including Locks and Grates	595	Miscellaneous objects of interest placed in the Main Avenue of the Building, not classified	847
23. Works in Precious Metals, Jewellery, &c.	671		

BRITISH COLONIES AND DEPENDENCIES.—CLASSES 1 to 30.

	Page		Page
Antigua	975	Malta	943
Bahamas	975	Mauritius	956
Barbadoes	971	Montserrat	976
Bermudas	971	Newfoundland	971
British Guiana	976	New Brunswick	969
Canada	957	New South Wales	988
Ceylon	937	New Zealand	1000
Channel Islands	939	Nova Scotia	970
East Indies	857	South Africa	949
Eastern Archipelago	988	South Australia	991
Falkland Islands	987	St. Helena	955
Gibraltar	947	St. Kitt's	976
Gold Coast and Ashantee	955	St. Vincent	975
Grenada	976	Trinidad	972
Ionian Islands	947	Van Diemen's Land	992
Jamaica	971	Western Africa	952



Digitized by the Internet Archive
in 2015

https://archive.org/details/b21495361_0002

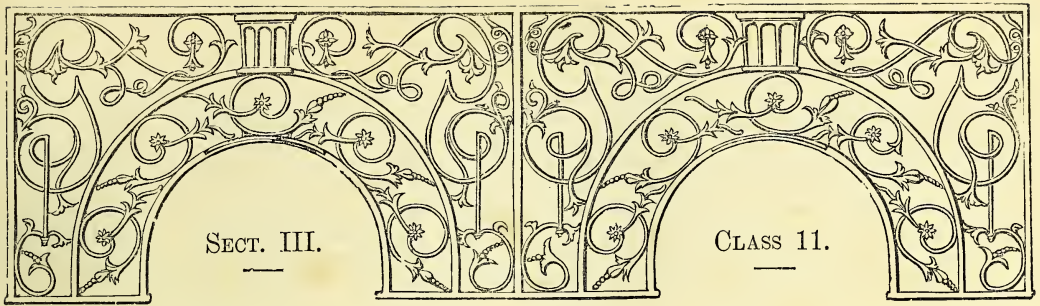

COTTON.

INTRODUCTION.

ANOTHER and third Section of the Exhibition is introduced by this Class, which includes the Manufacture of Cotton. This Section contemplates those results of human industry which naturally succeed to the Sections of Raw Materials and Machinery. The substance to be operated upon having been considered, together with the mechanical assistance necessary to carry forward the processes through which it has to pass in its progress from the raw material to the manufactured article, it now becomes an interesting study to turn attention to the product of the industry occupied in the preceding departments. While objects in the first Section may be regarded as in a passive or preparatory state, objects in the second must be considered in an active, and in the third in a complete condition, awaiting only their application to the purposes of life. This condition generally renders the articles contained within this Section less attractive than in the preceding and succeeding Sections. Rightly viewed, however, objects in this Section must receive a degree of attentive consideration not inferior to that bestowed on the former. The manufactured article may and should be regarded as the test of the perfection, first, of the raw material constituting its foundation, and, secondly, of the mechanical arrangements co-operative in its production. If the raw material has been wanting in any of the properties for which it is employed in the preparation, or if the manufacturing machinery has been defective in operation, the manufactured article offers, in many cases, certain evidence of these facts. And, conversely, the purity and perfect fitness of the material, with a state of efficiency in the manufacturing machinery, combine to produce a certain superiority in the manufacture which may be generally ascertained upon its careful examination.

The subject of the Class more immediately under notice, the Cotton Manufacture, receives, from its vast importance, a first position among manufactured articles. It comprises—A. Cotton, Yarn, and Thread; B. Calicoes, such as Sheetings, Long-cloths, Shirtings, &c.; C. Cords and Beaverteens; D. Muslins, as Cambric and Jaconet, Figured, Striped, &c.; Shawls, Handkerchiefs, &c.; E. Dimities for Furniture, Quilting, &c.; F. Colonial Woven Cotton, Handkerchiefs, Ginghams, &c.; G. Oiled Calicoes, &c.

The number of Exhibitors in this Class is not large, and their productions will be found grouped together in Areas I. J. from 1 to 8, at the North-western end of the Building, on the Ground Floor, near the Nave.

Various methods of manufacture are illustrated which must receive the notice of those concerned in this important department of commercial activity. The fitness of some articles, also, for the peculiar markets for which they are specially prepared suggests, even to the casual observer, interesting reflections on the different physical conditions of those for whom these articles are manufactured. There are several new applications of cotton to textile purposes. The most instructive parts of this collection, to those who have no technical interest in it, are those which contain arranged specimens in illustration of the stages of manufacture. The manufacture of thread is thus represented from the raw cotton to its completed condition. A case has also been carefully arranged which contains illustrations of the progress of the manufacture of cotton from the raw material to the finished results in the coarse and fine departments of the trade. One of the wonderful objects contained in this Class is a specimen of muslin made from No. 5,408 cotton-yarn, believed to be the finest ever made. That machinery could be brought to the degree of delicate movement, and precise and accurate adaptation to the slender materials of which this muslin is composed, may well be considered a great industrial triumph.

The history of the cotton manufacture in Great Britain presents several facts of the most wonderful description. No other manufacture represents this country in a position so important and influential, and in none has any department of industry attained, within the same interval of time, proportions so vast and relations so powerful. The cotton manufacture may be justly regarded as an evidence of the mechanical capabilities of this country. A little before the commencement of the present century it was in its infancy. One by one the great mechanical difficulties attendant upon its preservation were resolved. The spinning-frame was suggested by an accident, spinning by rollers was twice abandoned, and then successfully accomplished; the first mule worked in an attic, the first spinning-jenny in a cottage. Hargreaves and Crompton were poor weavers; Arkwright was a barber's apprentice. The beginning of this stupendous manufacture was truly insignificant, and contrasts wonderfully with its present position.

The following statistics form data by which this manufacture in its present state may be duly estimated:—The average annual imports have been estimated at about 550,000,000 lbs. weight, exclusive of deductions for exports. Of this quantity 500,000,000 lbs. are employed in manufacture, the annual value of the raw material thus employed being about ten millions sterling. About thirteen millions sterling are annually paid away in

machinery, &c., for the manufacture of this material, and about the same amount in wages to the persons directly employed in the factories, of whom the total number is taken at upwards of half a million, exclusive of 80,000 or 90,000 engineers and machinists immediately connected with the manufacture. The total annual value of the manufactured material has been approximatively represented at about thirty-six millions sterling. The effect on the population of the manufacturing districts has not been less surprising.

Although, therefore, little of external interest appears to belong to a bundle of cotton-yarn or a piece of calico, the study of its manufacture, exclusive of the exquisite mechanism by which it is operated upon, and the statistical facts which link themselves with its history, can never be unprofitable. The moral considerations connected with cotton factories form a subject of even higher interest and importance.—R. E.

- 1 JACKSON, JOHN, 73 *Adam Square, Edinburgh*—
Weaver and Producer.
1. Fine wool shawl, wove on the Spolino or loop principle, to show that this mode of weaving is applicable for figured wool shawls of the finest description.
2. Fine wool long shawl.
3. Edinburgh-made woven shawl.
- 2 SANDEMAN, HECTOR, *Tulloch Bleachfield, Perth*—
Manufacturer.
Cotton and lawn printed handkerchiefs; showing an improved red colour, obtained from the stalks of the *Rubia munjitha*, commonly called East Indian munjeet. One large bed-coverlet, in which the colours of black, red, and chocolate are dyed with munjeet.
[The *Rubia cordifolia*, also called *Rubia munjitha*, and by the natives of India mungeéth, is a species of madder, furnishing a fine dye, much used in the hill districts of India.—E. F.]
- 3 WALKER, JAMES & ROBERT, *Earlstown, Melrose*—
Manufacturers.
Cotton ginghams for female dresses, of fast colours; hand-loom wrought; yard wide.
- 4 PULLAR, ROBERT, & SONS, *Perth*—Manufacturers.
Umbrella and fancy ginghams; handkerchiefs; and woollen Derries.
- 5 AULD, BERRIE, & MATHIESON, *Glasgow*—
Manufacturers.
Book muslins, several pieces, each 12 yards long, 39 inches wide.
Several pieces of mull muslin; jaconet muslin; bishop lawn muslin, all of the same dimensions.
Saccharilla book muslin, several pieces, each 16 yards long, 45 inches wide.
Tarlatan book muslin, several pieces, each 16 yards long, 53 inches wide.
Saccharilla mull muslin, three pieces, each 20 yards long, 45 inches wide.
Harness book muslin, 8 yards long, 40 inches wide.
Harness book muslin curtain, 56 inches wide, 3½ yards long; 80 inches by 4 yards long, and 80 inches by 4 yards long.
Leno book muslin, samples of 27 inches wide 12 yards long. Harness book muslin curtains.
- 6 M'BRIDE & Co., *Glasgow*—Inventors and
Manufacturers.
Cotton table-cloths. Bird's-eye diaper and huckaback towelling. Furniture and jean stripes. Gingham, clan tartans, and cotton galas, and Hungarians and Derries, all made by patent power-loom.
Specimens of table-cloths and tartans, made by the same loom, the weft being from hemp, as prepared by Mr. Elijah Slock, of Renfrew, Scotland, for improving hemp, as a substitute for cotton.
- 7 ANDERSON, JAMES & ALEXANDER, *Glasgow*—
Manufacturers.
Ginghams, checked and striped. Cravats, checked muslin. Handkerchiefs, Turkey-red ground. Tartan muffler. Saxonies.
- 8 FINLAYSON, F., & Co., 25 *Dundas Street, Glasgow*—
Manufacturers.
Coloured sprig and striped lappet muslins; white and coloured striped; coloured spot; coloured satin striped tarlatan; white sprig striped and spot lappet; coloured gauze striped.
Lappet flounced muslin dresses.
- 9 LETHEM, BLYTH, & LETHEM, *Friday Street, London*; 49 *Virginia Street, Glasgow*; and *Academy Street, Belfast*—Manufacturers.
Specimens of different fabrics of plain muslins, woven from the same quality of yarn. Tamboured muslins for various articles of dress. Gingham for dresses.
- 10 & 45 OSWALD, STEVENSON, & Co., *Glasgow and Manchester*—Merchants.
Cotton yarns, of various colours, dyed in the west of Scotland, in bundles for export.
Cotton yarns, of various qualities and fineness, spun in the west of Scotland, in bundles for export, arranged according to Manchester classification.
Water twist. Mule twist. Fine yarns.
- 11 PATERSON, JAMIESON, & Co., 58 *Dundas Street, Glasgow*—Manufacturers.
Ginghams and handkerchiefs of various styles and qualities; fabric all cotton, hand-woven, or printed.
- 12 YOUNG, J. H., & Co., *Glasgow*—Manufacturers.
Fabrics suited for East India markets, consisting of bird-eye crape, plain and fancy net, book and mull muslins, Saccharilla mull, fine Swiss lappets, white and coloured.
Fabrics suited for home, American, and continental markets:—Piquet leno, blue; plain amber; checked pink; and striped green. Book muslin and Scotch lawn cambric handkerchiefs. Victoria, bishop, and Nainsook lawns. Jaconets. Swiss mulls. India mulls. India book muslins; Swiss book muslins. Tarlatan. Scotch elastic mull. Starched mull. India ledger. Checked book; striped book; tamboured book; tamboured jaconet. Lappet spot. White and pink spot, lappet stripe. Loom-sewed spot, white and sprig, coloured; dress made up of the same, with flounces. Paper harness sprig. Lappet sprig, stripe, and colonnade curtains. Harness leno; sprig and bordered book; and others.
- 13 HENRY & SONS, 81 *Buchanan Street, Glasgow*, and 120 *Cheapside*—Manufacturers.
Embroidered merino dresses. White tambour muslin dresses. Sprigged evening dresses, embroidered in the loom. Specimens of plain linen ginghams; all exhibited for quality and price.
In the embroidered merino dress marked A, there is only one repeat of the pattern from the bottom to the top of the skirt.
- 14 SYMINGTON, ROBERT B., & Co., *Glasgow*—
Manufacturers.
Harness book muslin and harness leno muslin window-curtains, all woven in the Jacquard loom. The design is called the "Humboldt pattern," composed of tropical plants and flowers.

- 15 THOMSON, JAMES, & SON, *Glasgow*—Manufacturers.
Cotton woven handkerchiefs in imitation of Indian handkerchiefs.
- 16 ANDERSON, JOHN & DAVID, *Glasgow*—Manufacturers.
Specimens of checked cotton gingham, and checked cotton cravats, in various qualities and styles.
- 17 DAVIDSON, WILLIAM & JAMES, & Co., *Glasgow*—Manufacturers.
Saccharilla book-muslin. Scotch tarlatan muslin. Tambooured book-muslin.
- 18 FYFE, HENRY, & SON, 62 *Queen Street, Glasgow*—Manufacturers.
Specimens of various gingham, hand-loom woven.
- 19 DIXON, PETER, & SONS, *Carlisle*—Manufacturers.
Grey and dyed yarns. Cotton checks and gingham. Romal handkerchiefs. Cotton shawls. Scarfs and robes. "Surongs." Stripes and "crossovers." Dyed "selampores." Grandvilles. Denims. Twilled stripes. "Panos da costa."—For home consumption and exportation.
- 20 MCGIBBON, EDWARD, *Carlisle*—Manufacturer.
Carlisle gingham, of six qualities, made principally for the American trade.
- 21 PEARSON & Co., *Carlisle*—Manufacturers.
Shirting stripes, and striped and checked fancy gingham and Hungarians.
- 22 LOWTHIAN & PARKER, *Carlisle*—Manufacturers.
Varieties of gingham, checks, stripes, poplins, &c., for the home, foreign, and colonial markets.
Samples of dyed yarn.
- 24 BROOK, JONAS, & BROTHERS, *Meltham Mills, Huddersfield*—Manufacturers.
Specimens of raw cotton; carded cotton; different processes of rovings; throstle yarns on bobbins (patent spun); mule yarns in cop and hank; sewing threads in hank, grey and bleached, of various numbers in 2, 3, 4, 6, and 9 cord. Thread and crochet cotton wound on spools.
- 25 HAYTHORN, JONATHAN WHITE, *Nottingham and Trent Mills, Burton-on-Trent*—Manufacturer.
Samples of sewing, knitting, and mending cotton. Lisle thread, white, and coloured, as used by glove and hosiery manufacturers.
Lace thread and doubled yarns, as used for making and figuring Nottingham lace.
Prepared cotton, white and coloured, as used by silk and ribbon manufacturers.
- 26 WALSH & WINDLEY, *Nottingham*—Manufacturers.
Specimens of thrown silk, used in the manufacture of lace, hosiery, and gloves. The produce of India, Italy, and China.
- 27 THACKERAY, JOHN, & SONS, *Nottingham*—Manufacturers.
Brown and white cotton gassed laced thread. Cotton Lisle and dressed cotton threads, in colours. Double-spun, or single cotton thread. Selvage threads. Warp-cotton-thread, gassed and ungassed; and other varieties.
- 28 GREENHALGH, RICHARD, & SONS, *Mansfield*—Manufacturers.
Samples of doubled cotton yarns, as used in the manufacture of various descriptions of lace, gloves, hosiery, ribbons, cloths, and for sewing and knitting.
- 29 HARRIS, W. S., *Leicester*—Patentee and Manufacturer.
Reels exhibiting specimens of sewing cotton, and patent reels constructed to prevent imposition as regards the length of cotton upon each.
- 30 RAWORTH & COMPANY, *Leicester*—Manufacturers.
Samples of six-cord and other sewing cotton.
- 31 O'CONNELL, JOHN, 27 *South Main Street, Cork*—Manufacturer.
Specimens of linen and cotton gingham.
- 32 CLARKE, J. P., *King Street Mill, Leicester*—Manufacturer.
Patent embossed wood, metallic and other reels, containing various lengths of two, three, six, and nine-cord sewing cotton. Reels also shown in their different stages of manufacture, from the rough hazel wood and metal to the highly-finished reels.
- 33 EVANS, WALTER, & Co., *Darley Abbey, Derby*—Manufacturers.
Sewing cotton of various kinds, made up in different forms for use.
- 34 RATCLIFF, Mrs., *Waltham Abbey*—Producer.
White knitted counterpanes.
- 35 BARLOW, GOODY, & JONES, *Bolton*—Manufacturers.
Pieces of figured quilting vesting; white quilting bed-cover, commonly called toilet quilts; coloured quilting bed-cover; and white welted bed-cover, welted quilts.
- 36 HOLLINS, W., & Co., *Pleasley Works, near Mansfield, Nottingham*—Manufacturers.
Merino, Cashmere, and cotton hosiery yarn. The single and two-threads are used in the midland counties in the manufacture of hosiery, and the three-threads are generally bought for the Continent for knittings, and applied to hosiery purposes there.
- 37 MARTIN, WILLIAM, & SON, *Bolton*—Manufacturers.
Damask diced and plain furniture dimity, for bed-hangings, curtains, &c.
- 38 COOK, W. W. & J., *Little Bolton*—Manufacturers.
Cut brocade mull, flounced dress, white, for ladies. Plaited brocade quilting skirts, white. Plaited brocade skirts, white.
Welted brocade skirts, white. Brocade stripe. Cut brocade mull, in the piece, white.
- 39 MYERSCOUGH, STEEL, & Co., *Bolton*—Manufacturers.
Counterpane—bed-cover. Quilting bed-cover, commonly called toilet-quilt. Fine diamond quilting, for waistcoats.
- 40 BARNES, THOMAS, *Farnworth Cotton Mills, Bolton*—Manufacturer.
White Polynesian swansdown, combining fineness of back with considerable thickness of substance.
Piece of moleskin in different stages, illustrating the progressive method of raising, dyeing, printing, and finishing a substitute for low woollen cloths.
Piece of printed moleskin, pattern designed and registered by the exhibitor; printed by John Jackson & Co., Manchester, and finished by John Whitehead's (of Elton) patent process of raising and finishing after dyeing and printing.
- 41 CROSS, J., *Bolton*—Manufacturer.
Twilled long-cloth and shirting.
- 42 SUDWORTH, JOSIAH, *Bolton*—Manufacturer.
Counterpane, exhibited for weaving.
- 43 WATERS, J. & Co., *Fountain Street, Manchester*—Manufacturers.
Small wares, knitting and reel cotton, ribbon wire, webbing, tapes, fringes, cotton-laces, bindings, &c.
- 44 CHRISTY & SONS, *Fairfield Mills, near Manchester*—Manufacturers.
Royal Turkish bath-towels.
The novelty consists in the absorbing power of the

surface, having a plush or looped surface on both sides, and in the patent mode by which this is accomplished on one or both sides. The great softness of the cotton surface adapts it peculiarly for young children. The advantages of cotton towelling have been long appreciated in the Eastern baths. The linen nap or plush affords equal absorbency, and produces a sharper feeling to the skin, whilst the retaining of the cotton ground gives a pliancy of material which has long been a desideratum in towelling with a sharp rough surface. Produced by "Holt's Patent." The texture is applicable to shawls, counterpanes, and other articles.

46 WALKER, WILLIAM, 13 *Marsden's Square, Manchester*—Manufacturer.

Cotton cloth, with specimens in imitation of woollen broad cloth, beavers, Witneys, &c.

47 CROSS, C., & Co., *Corporation Street, Manchester*—Manufacturers and Joint Patentees.

Very wide doeskins, pushed on one side, and on both sides; lambskin; shoe linings; white twill; dyed cord; striped everlasting.

Specimens of various articles of wearing apparel, without seams, produced by the exhibitors' patent machinery.

48 JOHNSON, JABEZ, 44 *Spring Gardens, Manchester*—Manufacturer.

White and coloured figured wove quilting for vests.

White diamond quilting for vests.

White and coloured bed-covers.

White and coloured toilette covers.

49 MAJOR & GILL, 49 *Cannon Street, Manchester*—Manufacturers.

Patent double coutils and nankeen for stays, consisting of two cloths woven together, and stitched, during the process of weaving, at any interval of space required for the various patterns of stays.

50 GLOVER & DUNN, *Manchester*—Manufacturers.

Calicoes, &c., with examples of cotton in various stages of manufacture. India jaconets. Cambric of various qualities.

Fine power-loom shirtings, finished in imitation of linen, having 140 by 160 threads in the square inch.

51 WALMSLEY, HENRY, *Fir Mills, Failsforth, near Manchester*—Importer.

Table-cloth manufactured by power. Materials—1st, silk, in colours; 2nd, silk and worsted, in colours; 3rd, cotton and worsted, in colours; 4th, cotton only, in colours. In the centre is a view of the "Exhibition Building," 80 inches wide, 110 long, from the official design by Paxton, with emblematic borders representing Peace and Commerce with the nations; and a procession displaying the costumes of Europe, Asia, Africa, and America, *en route* to the Exhibition.

Specimens of figured weaving by power, in different fabrics.

Woven picture, in silk and in cotton, of the "Exhibition Building," with emblematic borders; imitation of engraving.

Goose's patent Jacquard machine for producing table-cloths.

52 SPENCER, JOHN, & SON, *Marrriott's Court, Manchester*—Designers and Manufacturers.

Cotton, white woven, figured summer bed-quilt, quilted in the loom.

Cotton, coloured woven, figured bed-quilt.

Cotton, coloured woven, figured Dresden bed-quilt, quilted in the loom.

Cotton, figured quilting hangings, for beds or windows; a new application of the fabric to this use.

Quilting waistcoatings: white quilting figured waistcoat; and coloured woven quilting waistcoat—figured in the loom.

53 BAZLEY, THOMAS, *Manchester*—Manufacturer.

Case, containing illustrations of the transition progress of the manufacture of cotton, from the raw material to the finished results, in the coarse and fine departments of the trade.

[No. 1 in the case is a sample of New Orleans cotton; No. 2, blown or cleaned cotton; No. 3, first carded; No. 4, second carded; No. 5, drawing roving; Nos. 6, 7, and 8, rovings; Nos. 9, 10, 11, and 12, cops and hanks, mule yarns, No. 1 to 60; Nos. 13 and 14, throstle-yarn, Nos. 10 and 30; Nos. 15 and 16, shuttle cop-mule yarn, Nos. 30 and 120; Nos. 17 and 18, hosiery yarn, Nos. 5 and 50; Nos. 19 and 20, threefold sewing-thread, Nos. 20 and 40; Nos. 21 and 22, white and printed calico; Nos. 23 and 24, white and printed fustian; No. 25, Sea Island cotton; No. 26, blown or cleaned cotton; No. 27, first carded; No. 28, second carded; No. 29, drawing roving; Nos. 30 to 34, rovings; Nos. 35 to 37, mule-yarn, in cops and hanks, Nos. 200, 400, and 600; No. 38, crape-yarn, No. 100; No. 39, lace thread, two-fold, No. 200; No. 40, sewing-thread, three-cord, No. 200; No. 41, sewing-thread, six-cord, No. 400; No. 42, sewing-thread, nine cord, No. 600; Nos. 43 to 45, white, printed, and figured Scotch muslin; Nos. 46, 47, and 48, white, printed, and figured lace.]

54 HOULDSWORTH, THOS., & Co., *Little Lever Street, Manchester*—Cotton Spinners.

Specimens of fine cotton yarn, and of doubled yarn, or fine cotton lace thread, arranged in segmental compartments.

Specimens of the same Nos. of yarn, and of thread, in hanks.

55 JOHNSON, ROBERT, & NEPHEW, 95 *Watling Street*—Importers.

Book-muslin for curtains, figured in the Jacquard loom; the same, new design, palm and plantain tree alternate.

Leno muslin, figured.

Swiss manufacture, for curtains, embroidered on book-muslin; the same, on British net.

Infant's long robes, and girl's frock, embroidered.

56 BRADBURY, GREATORREX, & BEALL, 6 *Aldermanbury*—Proprietors.

Specimens of window curtains.

57 LINCOLN & BENNETT, 2 *Sackville Street, Piccadilly*, and 58 *Union St., Borough*—Inventors and Manufacturers.

Hats with calico foundation. Drab hats for India, &c.

Chess-table, &c., made of prepared calico, turned, carved, japanned, &c., in imitation of grained wood.

58 ROGERS, LOWREY, HOLYLAND, & Co., 91 *Watling Street*—Proprietors.

Muslins manufactured in Scotland, denominated "Books," Swiss, Tarlatan, Nainsook, Mull, and Scotch cambric.

59 MAIR, SON, & Co., 60 *Friday Street, London*, and 163 *Ingram Street, Glasgow*.

Patent muslin window curtains, figured in the loom. The pattern and execution are obtained at reduced cost by a new arrangement of the Jacquard loom.

Leno window curtain.

Samples of muslin dresses, figured in the loom.

Specimen of the finest plain muslin, manufactured from No. 5408 cotton yarn, spun by T. Houldsworth, Manchester. Bleached by John Wallace and Co.

Scotch needle and tambour work, including embroidered merino and muslin dresses.

Printed flannels, twilled bandannas, and cambric handkerchiefs.

60 HORROCKSES, MILLER, & Co., 9 *Bread Street*—Manufacturers.

Long cloths and twilled shirtings.

61 CROCKER, J. & A., 51 *Friday Street*—Producers.

Harness woven muslins, for curtains.

Complete drapery, blind and curtains of harness woven muslin, showing its adaptation for window decoration.

Printed cotton, for furniture uses; the colours produced by machine, and by machine and blocks.

62 OWTRAM & Co., 13 *Walling Street*—Manufacturers.

Brocaded cottons and cotton damasks. Satin brocades and flush sprigged muslins.

63 MARSLAND, SON, & Co., *Bridge Mill, Blackfriars, Manchester*—Manufacturers.

Crochet and sewing cotton.

64 DAILY & Co., 9 *St. James's Place, Hampstead Road*—Producers.

Specimens of soiled and faded satins, dyed and embossed.

65 ALLEN, R., *Sackville Street, Dublin*—Producer.

Free labour cotton goods.

[The cotton manufacture forming an important feature in the commercial activity of this country, it may not be uninteresting to take a rapid glance at its history and products. It is worthy of remark, that the name "Cotton," is almost the same as "Cotnot," that which is given in Hebrew to the first clothing which was put upon man; and there is reason to believe, that this fabric was employed for that purpose in the East, at a very remote period. The "fine linen" of Egypt is extremely ancient; but the "fine cotton" of India rivals it in antiquity, beauty, and utility. The microscopic examination of the structures of these fabrics, recently made in order to determine the nature of mummy-cloth (which is unquestionably linen), has proved that they are essentially different in form; the fibres of linen being cylindrical and tapering at each end, and the fibres of cotton being flat and ribbon-like.

The Hindoos, from whom we derive the knowledge of its manufacture, have not only made cotton cloth from time immemorial, but have excelled all other nations even to this day, in the delicacy of their fabrics. Herodotus mentions it as the common clothing in India; and it is spoken of by Arrian and Strabo as well known. Cottons were articles of trade and of dress in Russia in 1252; and were generally used by the Chinese in 1316. Cotton cloth was brought to London in 1590, from Benin; and it was ascertained about a century previous, to have been the chief article of dress among the Mexicans. Its manufacture was originally brought to Europe by the Moors of Spain; but it was not till after the establishment of their commerce with India, that the Dutch began to fabricate cotton cloths at home. The Protestants, driven by persecution from the Netherlands, brought this manufacture to England in the reign of Queen Elizabeth.

Our ordinary cotton fabrics have their counterpart in the original manufactures of India; and the native muslins of Dacca in Bengal still rival the productions of the exquisite machinery of England. The former have obtained their superiority from the skill acquired by manual dexterity transmitted through a long lapse of ages; the latter, from that of little more than half a century of well-exercised mechanical ingenuity. The various kinds of cotton fabrics brought from India, were originally distinguished by the names of the places where they were made; as, jaconets, mullmuls, betelles, tarlatans, tanjees, bukes, terridams, doreas, &c. Imitations of these by our manufacturers retain their names; and additions and changes are made according to the improvements introduced.

The two great emporiums of the cotton manufacture are Manchester and Glasgow; the former having Bolton for its assistant, in the production of muslins and the finer sort of goods; and the latter, Paisley. Both these cities have risen, in consequence of the wealth produced by their manufactures, from the position of third-rate towns, and known only by historical associations, to the

rank of being second in the kingdom, and honourable rivals in magnitude and importance. The pattern-cards of Manchester goods which have been sent over to the Continent by some eminent manufacturers, have at times exhibited specimens of 1,500 different kinds of cotton manufacture, varying in fabric and design, from the coarsest cloth to the finest muslins; and in colours, from the richest chintz to the plainest goods. The term "Manchester and Glasgow Warehouse," exhibited on a sign-board in London and other towns in this country, indicates that all kinds of cotton goods are to be obtained of the exhibitors.

The general name of calico has been applied to the plain white cloth manufactured from cotton, from the circumstance of this article having been first imported from Calicut, in 1631, the place of its original and principal manufacture. As calico increases in its quality and strength, it is called long-cloth, duck, and double warp. Calico-shirting or twine-cloth is made to imitate and supersede linen; and in patent-twist, the yarn is more closely entwined than in common calico. Sheeting-calico, as its name implies, is a substitute for linen-sheeting, and is preferable on account of its cheapness and warmth. Printed calicoes, or prints, at first the imitations of those of India, are now produced in patterns of an indefinite variety every year. Calicoes are frequently impregnated with a made paste of spoiled flour called "the dressing," which renders it difficult to ascertain their quality. This dressing is given merely to improve their appearance.

The peculiar style of printed calico, called chintz, originally from India, and in which the figures are at least of five different colours, impressed upon a white or coloured ground, are now made by our own manufacturers with great success, as to beauty of design and richness of colour. The invention and the drawing of patterns for printing alone gives employment to artists of a peculiar class; and the variety produced is immense, in order to satisfy the perpetual demand for change produced by fashion.

It is to the production of fine muslins, that the chief efforts of our cotton manufacturers have been directed, with a view to excel the wonderfully delicate and light fabrics of India. It is stated that the turbans of some of the rich Mohammedans at Delhi were made of muslin so fine that thirty ells did not weigh four ounces; and that some of their broad webs might be drawn through a ring of moderate size, the tissue being so exquisite that it seemed more like the work of insects than of men, resembling in the language of Eastern hyperbole, "the woven wind." The threads of a specimen of this manufacture in the Museum of the East India Company, when examined with the microscope, were found though spun only by the distaff and spindle, to surpass our machine-made muslin in fineness, but to be inferior in regularity. Twenty yards of the yarn of which this muslin was made weighed only a grain; and a pound of it would have

reached the length of 115 miles. In England yarn has been spun so fine, that a pound would extend to 167 miles in length; but this could not be woven by our machinery. The price of the Dacca muslin has been, when brought to this country, from 10 to 12 guineas per yard. By the employment of machinery, and the division of labour, we are enabled to produce muslin much cheaper than the Hindoos, and even of finer texture; but their muslin is richer, softer, and more durable, and still maintains its reputation. The same may be said of their calicoes, gingham, and chintzes, which form the staple commodity of the Circars. Though nearly driven out of the European markets by cheap and successful imitations, they are still preferred in the East, where the merchants consider that they are able to distinguish by the touch, and even by the smell, the genuine productions of the Indian loom.

Varieties of muslin are jaconet, a light kind of muslin, open and soft, but stouter than the mull: the name is supposed to be a corruption of Jaghernout, the place where they were made; it is used for dresses, neckcloths, &c. Nainsook is a thicker sort of jaconet, plain and striped. Mull muslin is a very thin and soft kind, used for dresses, trimmings, &c. Seerhand is between nainsook and mull, and particularly adapted for dresses, retaining its clearness after washing. Buke muslin is a plain clear kind, woven for working in the tambour. Foundation muslin is open-worked, used for stiffening dresses and bonnets. Leno is thinner and clearer than buke muslin; a sort of cotton gauze, used for window blinds. Cambric muslin is an imitation of cambric, a linen fabric; it is sometimes glazed, white and coloured for linings, and twilled, figured, striped, or corded. Cord and fancy checks, are cambric muslins with stripes and cords placed chequer-wise, by thick threads being introduced into the warp or weft. Figured muslins are wrought in the loom to imitate the tamboured muslins, which are embroidered by hand on the tambour. Glasgow is the chief seat of the tamboured muslins. Of cotton cambric there are two kinds; that used for dresses, white or printed, made chiefly in Lancashire; and that used for the same purposes as French cambric, made chiefly in Glasgow.

Cotton damasks, huckabacks, and diapers, are made in imitation of articles of the same name in linen; they are cheaper, but less durable in fabric and in whiteness. Cotton ticks are plain and twilled, in imitation of linen ticks; and there is a kind called union tick, composed of linen and cotton. Gingham is a thin chequered cotton. Counterpanes, a corruption of counterpoint, have small

protuberances arranged according to various patterns. Marseilles quilts are more elegant than the former; it is a double cloth, with a third of softer material between, kept in its place by the quilting done in the loom. Cotton quilting is made for waistcoat-pieces, resembling diaper. Jean is a twilled cotton, both striped and white. Satin jeans are woven like satin, with a smooth glossy surface, and are used for stays, shoes, &c. Dimity, an article well known, is made striped or plain; now much used for curtains. Fustian is a coarse twilled cotton, comprehending several varieties, as corduroy, jean, velveret, velveteen, thickset, thickset cord, and other stout cloths for men's wearing apparel. Common plain fustian is called pillow; when of a strong twilled texture, and dropped before dyeing, it is called moleskin; and when shorn after dyeing, it is called beaverteen.

Cotton goods, particularly the finer fabrics, as muslins and bobbin-net lace, are subjected to a process by which the downy fibres of the web as it comes from the loom are removed, and the fabric is presented in a more finished state of manufacture. This process formerly consisted in passing the web in its whole width rapidly over and near to the upper surface of a semi-cylindrical piece of red-hot iron placed horizontally, by which the fibres projecting from the surface were consumed in a moment, while the fabric itself passed unhurt over the burning mass. Had the machinery by which this was effected been suddenly stopped before the web was raised from its perilous position, the whole would have been enveloped in flames.

This method of singeing muslin, which was practised at Glasgow and in Lancashire, has been in some factories superseded by Hall's patent process, which consists in the application of gas to effect the same purpose as the red-hot iron. The latter is replaced by a tube similarly placed, and perforated in its upper side with numerous small holes as jets through which the gas passes. When the gas is ignited, the muslin is passed rapidly over the flame in a manner similar to that already mentioned. Improvements were introduced into this process by the patentee, by which a draught of air is created over the series of jets when acting as burners; and the web being then rapidly passed over these burners, the air forces the flame of the gas through the interstices of the fabric, and all the loose and projecting fibres of the thread composing the web are instantaneously consumed as before, without in the least injuring its substance or texture. The application of this process creates the distinction between gassed and ungassed goods.—R. W.]



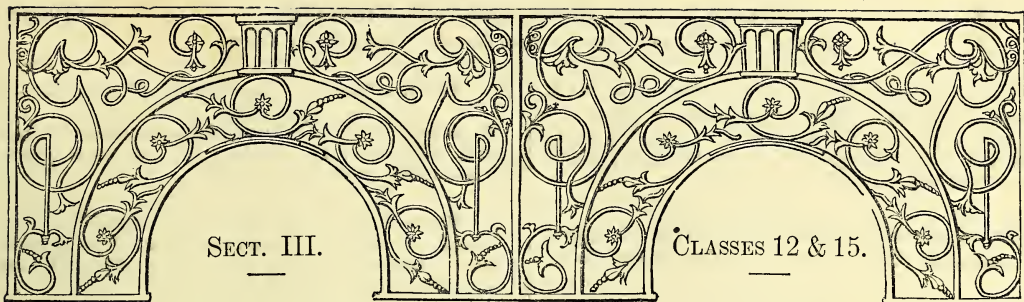

WOOLLEN AND WORSTED.

INTRODUCTION.

THE Classes which are here united together are so treated in consequence of the practical difficulties attendant upon their separation being so great as to render it advisable rather to include the objects embraced by both Classes under one general division. The manufacture of woollen and worsted goods can scarcely be considered inferior in importance to that of cotton, employing a large amount of capital, and giving support to many thousands of operatives and others. The number of Exhibitors in the conjoined Classes exceeds the proportion of those in the former Class by a very large sum. In Class 11 there are little more than sixty Exhibitors; whereas, in the United Classes, 12 and 15, there are about five hundred. This disproportion is rendered in part accountable by a closer examination of the Catalogue, when it will be found that the great majority of the Exhibitors in Class 11 (Cotton Manufactures) are really producers of the materials they display, whereas in the present Classes many are producers, but a very large number are simply proprietors, or, in the commercial world, venders of such materials—a class of persons always numerically greater than the preceding.

Class 12 embraces the following subdivisions:—A. Broad Cloths; B. Narrow Cloths; C. Flannel; D. Blankets; E. Woollen Cloaking; F. Serges; G. Tartans; H. Worsted Stuff Goods; I. Woollen, Worsted, Alpaca, and Mohair Yarns.

Class 15 includes mixed fabrics and shawls under the subdivisions—A. Mixed Woven Fabrics, such as Cotton, Silk, and Linen Warps; and B. Shawls, woven and printed.

The position in the Building of the articles included in these Classes is generally in the South Transept Gallery, and on the Ground Floor, on the left hand, or South side (proceeding westward), near the western termination of the Nave. In the latter are arranged the cloths, worsted alpaca, and mohair goods; shawls, &c., are displayed in the Gallery, and extend through Areas 10 to 17. From the delicacy of their nature and colours they are inclosed in glass cases, the artistic arrangement of which gives a pleasing character to this part of the Gallery.

The great manufacturing localities for goods contained in these Classes are Chippenham, Frome, and Bradford, in Wilts; Wootton-under Edge, Stroud, Leeds, Huddersfield, and Halifax; Galashiels, Hawick, and Selkirk, are localities in which particular descriptions of wool and narrow cloths are produced. Blankets are manufactured chiefly at Witney, Dewsbury, and Oakhampton. Flannel is produced in large quantities in the Principality, also at Rochdale and Stroud. Tartans form a characteristic manufacture of several northern towns. But the town of Bradford presents the most conspicuous example of a locality deriving a large share of prosperity from the production of a peculiar description of goods—the worsted stuff goods. In 1801, this town had a population of about 6,400, which, in thirty years, had multiplied to upwards of 23,000, and has since increased even more rapidly. This is due, in a great measure, to the extraordinary success which has attended the manufacture of mixed fabrics, and especially of worsted stuff goods. The spinning of worsted yarn alone employs many extensive factories, which supply others equally extensive with material for weaving the goods by power-looms. A very large population, not under 9,000 or 10,000, is now employed in these factories, or in connection with them. Latterly the alpaca manufacture has risen into great importance, and with the manufacture of fabrics made of wool and cotton, and of wool and silk, constitutes the staple industry of this locality.

The woollen manufacture generally has for a long period been regarded as one of the most important branches of our national industry, and though less extensive than that of cotton, still holds a highly influential position, and furnishes the means of support to many thousands of our countrymen. It has been computed that not fewer than 312,500 people are employed on the whole in this manufacture, which has been calculated to amount to the annual value of about 25,000,000*l.* The introduction of new materials either for use alone, or in combination, has at times given an extraordinary impulse to the manufacture, and the character of the goods produced has undergone several important modifications. The manufacture largely carried on at Dewsbury, in Yorkshire, of a coarse cloth from woollen rags, is very interesting. The rags are torn up by machinery, and their fibrous material is entirely separated; it is then spun in low numbers, and made into a coarse description of cloth used for haize, table-cloths, &c. The reproduction of a woven fabric, from material until recently regarded as entirely waste and useless for such purposes, is a striking illustration of the adaptive ingenuity of the present day.—R. E.

1 SCOTT & WRIGHT, *Vigo Street, Regent St.*—Designers.
West of England elastic doeskins, in Scotch clan tartan patterns for trousers; new style in the same, and angola for trousers; Scotch angolas for trousers, and mauds for railway rugs and shawls for travelling.

2 EAST, LONDON & HOLLAND, 10 *Old Bond St*—Designers.
Specimens of fancy woollen trouserings and coatings.

3 SCHOFIELD, BROWN, DAVIS, & HALSE, 1 *Gresham St.*—Proprietors.

Flannels in a variety of styles, comprising—
1. Royal Victoria flannels, manufactured from yarn spun from silk and wool. This fabric is superior to flannels made entirely of wool, in the following particulars. It is less irritating to the skin; it shrinks less in washing; the silk increases the strength and durability of the texture, and renders it less liable to tear.

2. Merino flannels, made from yarn spun from cotton and wool. This article is exhibited on account of its durability and cheapness.

3. Flax flannels, woven from yarn spun from a mixture of wool and flax fibre; the latter prepared by the Chevalier Claussen's patent process.

4. Silk warp flannels: these goods are adapted for mantles and the nursery. Two embroidered opera cloaks are exhibited as illustrating the adaptation of the fabric to articles of dress.

5. Thibet flannels, made of choice Saxony wool.
6. Flannels in fancy dyes, comprising pink, rose, cherry, crimson, sky blue, gentianella, orange, canary, scarlet, &c.

4 TWEEDEALE, JACOB, & SONS, *Healey Hall, near Rochdale, and 56 Wood Street, London*—Manufacturers.

Pieces of superfine Saxony flannel; fine cricketers' flannel; fine anti-rheumatic flannel; and fine imitation Welsh flannel.

5 LEACH, JOHN, & SONS, 83 *Wood Street*—Manufacturers.

Lancashire flannel, made from English and Australian wools. Imitation Welsh flannel, from the same. Medium Welsh, or "anti-rheumatic flannel." Twilled, milled, or cricketing flannel. Saxony flannel and coating. Swänskin. Gauze Saxony.

6 WILKS, JONAS, 79 & 80 *Watling Street*—Proprietor and Designer.

Striped woven flannels.
Lancashire and Welsh flannels.

7 FOX BROTHERS & Co., 27 *Tokenhouse Yard, and Wellington, Somerset*—Manufacturers.

White and dyed woollen serges.
White woollen blanketing, and blankets.
Hosiery yarns.

8 POWELL, SAMUEL, 52 *Regent Street*—Inventor, Patentee, and Proprietor.

Double-faced cloth, having a perfect finish on each side, of two distinct colours, woven in one single fabric.
Specimens of superfine double-faced cloth for coats, vests, trousers, ladies' paletots; and stout cloth, for overcoats.

The novel application of these fabrics embraces every description of clothing which can be made reversible upon the patent mode of construction of the inventor. The illustration of their application will be seen in Class 20.

9 BROWN & FORSTER, 5 *Vigo Street, Regent Street*—Proprietors.

Trouserings, in doeskins and cassimeres; in Scotch tweeds, and natural Cheviot wool.
Waistcoating of wool, of wool and silk, of silk, of cotton, and of China grass; all of British manufacture. Embroidery on cloth and on silk.

10 MURLEY, W. & C., 4 *Bow Churchyard, Cheapside*—Inventors.

Waistcoat lengths of various designs in cotton; silk and cotton; silk, wool, and cotton; silk and wool plush; silk and linen; wool and cotton.

11 GOODWIN, JOHN, *Lawrence Lane*—Proprietor.

Samples of vestings. White and coloured quiltings, all cotton. Livery valencias, silk figured cashmeres, and China grass lustres, mixed fabric.

12 BULL & WILSON, 52 *St. Martin's Lane*—Proprietors.

Fine black cloth, for gentlemen's coats.
Fine blue cloth, manufactured at Bradford, Wilts, from Saxony wool, indigo dye, suited for naval officers' uniforms.

Fine scarlet cloth, manufactured at Stroud, Gloucestershire, suited for military officers' uniforms.

Black beaver cloth, for overcoats; woven by a patent process, invented by Mr. Daniells, of Freshford Mills, Bath. Two shuttles are employed in the weaving, the one carrying the fine or surface thread, the other the stout or backthread, each placed in a distinct plane.

The annexed cut shows a section of cloth woven on the patent process, in which the arrangement of the threads in the patent cloth is represented in fig. 1 as woven with two shuttles, and in fig. 2 as woven with three.

Fig. 1.

Fig. 2.

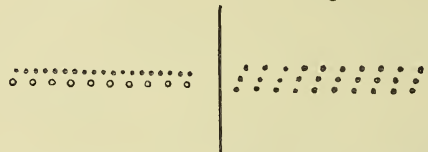

Reversible Witney cloth, for travelling coats, &c., manufactured by Daniell's patent process.

Registered double-surfaced beaver, for overcoats and pantaloons.

Himalaya cloth, for warm outside garments; made from the wool of the Cashmere-shawl goat.

Fine coloured cloths, for coats, manufactured at Bradford, Wilts.

Clarendon cloths, for summer paletots, manufactured at Trowbridge.

Black milled doeskin, for pantaloons.

Fine single-milled cassimeres and Sardinian cloth, for waistcoats and embroidery, manufactured at Stroud; the same, embroidered.

Single milled fancy doeskins, of new designs, for pantaloons, manufactured at Trowbridge, Wilts.

13 CLARK, JOHN & JAMES, *Basinghall Street, London, and Trowbridge, Wiltshire*.

Woaded black single cassimere; patent beaver, Venetian, and ladies' cloth.

Satin-face doeskin; satin-face single doeskin. Milled and single doeskin.

Fur Janus beaver.

14 SMITH, JOHN BLAND, & Co., 38 *Basinghall Street*—Proprietors.

Woollen cloth rendered waterproof, without being impervious to air, the texture and appearance unaltered.

15 LOCKE, JAMES, 119 and 127 *Regent St.*—Manufacturer.

Scotch tweeds for deer-stalking, riding, and walking; and for summer and warm climates.

Cheviot wool tweeds, for shooting and country wear; specimens of the wool of which they are made in its various stages of manufacture.

Regulation tartans, as worn by the Scotch Highland regiments.

Scotch mauds, for riding and travelling. Ladies' clantartan shawls.

Scotch linsey-woolseys, for the sea-side.

- 16 STANCOMB, J., & SON, *Trowbridge, Wilts, and 19 Basinghall Street, London*—Manufacturers.
Samples of mixture doeskins, fancy moleskins, fancy Angolas, and fancy moleskins, exhibited for fabric and texture.
Samples of fancy Angolas, twilled buckskins, imperial cloths for summer coats, and thin and stout Venetian cloth.
- 17 STANCOMB, W. & J., JUNRS., *Trowbridge, Wilts, and 14 Basinghall Street, London*—Manufacturers.
Several samples of single elastic, and single moleskin, of fancy texture; all wool.
- 18 SHEPPARD, W. B. & G., *Frome, Somerset, and 7 King Street, Cheapside*—Manufacturer.
Woollen cloths, Venetian cloth, and fancy coatings. Single and milled, plain and fancy cassimeres.
- 19 BARBER, HOWSE, & MEAD, *19 St. Paul's Churchyard*—Designers and Proprietors.
West of England and Yorkshire superfine broad cloths. Moscow and royal British beavers. The Alpa Vicuna royal shawl. Royal beaver shawl.
- 20 BRETT BROTHERS & CO., *Wood Street*—Designers.
Piece and wool-dyed black cloths. Wool-dyed rifle-green cloths. Piece-dyed black cassimeres. Wool-dyed black doeskins. Fancy trouserings of various styles and qualities.
- 21 HUDSON and BOUSFIELD, *Leeds*—Manufacturers.
Llama, Venetian, and superfine cloths.
- 22 SLATER, E., *Leeds*—Manufacturers.
Black wool barathea cloth.
- 23 WALKER, JAMES, & CO., *Bedford Street, Leeds*—Manufacturers.
Mohair cloths, various colours, for making and trimming ladies' paletots, first and second quality. Ladies' cloths, Union, and all wool Tweeds, various colours, for ladies' and children's cloaks.
Fancy woollen cloakings, for lining gentlemen's coats.
- 24 SNELL, J., *Leeds*—Manufacturer.
Superfine twilled summer cloth.
- 25 HAGUES, COOK, & WORMALD, *Leeds*—Manufacturers.
Spanish stripe and drab beaver cloths; white, coloured, and horse blankets.
- 26 IRWIN, E., *Leeds*—Manufacturer.
Woollen cloths.
- 27 EYRES, W. & SON, *Leeds*—Manufacturers.
Woollen cloths.
- 28 HARGREAVE & NUSSEYS, *Farnley Low Mills, near Leeds*—Designers and Manufacturers.
Royal chameleon, elastic; transferable cloth; Vicuna fur, with woollen back; dyed black cloth, from colonial wool.
- 29 SMITH, WM., & SON, *Leeds*—Proprietors.
Piece-dyed sound wool black cloths. Mohair cloths, coloured. Mixed napped Petershams. Indigo dyed blue pilots. Corbo beavers. Mixed Witney.
- 30 LAMBERT, J., *Leeds*—Manufacturer.
Ladies' coatings; tweeds, Circassian, Venetian, and mohair cloths.
- 31 BINKS, B., *Leeds*—Manufacturer.
Superfine woollen cloths.
- 32 THORNTON, FIRTH, & RAMSDEN, *Leeds*—Manufacturers.
Superfine cloths, silk and cotton warp; cashmerettes, and blankets.
- 33 LUPTON, WILLIAM, & CO., *Leeds*—Proprietors.
Olive cloth. Blue carriage lining, indigo dye. Blue cloth, indigo dye.
- 34 SYKES, JOHN, & SON, *Woodhouse Lane, Leeds*—Manufacturers.
Woollens:—Dyed black, medium, fast colour. Brown, light olive, moss olive, dark olive, and light bottle-green cloth, common colour.
Bottle-green, woaded colour.
Light blue, indigo dye.
Invisible green, wool-dyed black, and piece-dyed black, common colour.
- 35 STOW BROTHERS, *Leeds*—Manufacturers.
Superfine woollen cloths.
- 37 FIRTH, EDWIN, & SONS, *Heckmondwike, near Leeds*—Manufacturers.
Blankets: coatings of alpaca wool, mohair, and camel's hair.
Cotton diaper rugs, bleached and unbleached.
- 38 HENRY, A. & S., & CO., *Leeds*—Manufacturers.
Woollen cloths and cotton warp cloths.
- 39 BATESON & CO., *Leeds, Yorkshire*—Manufacturers.
Black cloths, piece and wool dyed.
Indigo blue cloth, wool dyed.
Blue, green, claret, and brown cotton warp cloth, piece dyed.
Brown, green, and blue cloth, wool dyed.
Medley cloths.
- 40 PAWSON, SON, & MARTIN, *Stonebridge Mill, near Leeds, Yorkshire*—Manufacturers.
Black cloths, piece-dyed, true colours.
Mulberry ladies' habit cloth, wool dyed, true colour.
Black cloth, and rifle Venetian, wool dyed, woaded colour.
Blue Venetian, wool dyed.
Olive, black, and rifle, ladies' cloths; and rifle-habit cloth, wool dyed, woaded colours.
- 41 SWAINE, JOSHUA & EDWARD, & CO., *Gomersal and Leeds*—Manufacturers.
Superfine wool-dyed indigo blue Witney duffels. Police and Canadian cloths.
- 42 COOPER, D. & J., *Leeds*—Manufacturers.
Superfine woollen and doeskin cloths.
- 44 HOTHAM & WHITING, *Leeds*—Manufacturers.
Yorkshire flannel.
- 45 CHEETHAM, C. G. & W., *Calverley, near Leeds*—Manufacturers.
Specimens of superfine olive broad cloths of Australian wool. Bottle-green broad cloths. Sample of Australian wool, in case of Australian mahogany.
- 46 SAVILLE, J., *Leeds*—Manufacturer.
Oxford, pilot, and army cloths.
- 47 GOTT, BENJAMIN, & SONS, *Leeds*—Manufacturers.
Woollen cloths:—for the home trade: brown, olive, and blue; and black woaded.
For the American market: brown, green, olive, bottle, black, Adelaide, olive brown, olive, Strasburgh, bottle rateen. Drake neck, black, dahlia, Adelaide, olive brown, and olive rateen.
For the Chinese market: scarlet, salmon, black, green, gentian, blue, dahlia, ash, purple, and Burgundy.

For the Russian market : orange, green, sky-blue, scarlet, yellow, carmine, and gentian.
For the home trade : lady's brown, ruby, lavender, dove, chocolate, and gentian, cloth.

- 48 SMITHSON, THOMAS, *Bramley, near Leeds*—
Manufacturer.
Black medium cloth, piece-dyed.
Dark blue ladies' cloth; fine habit cloth; black habit cloth, wool dyed; superfine goods of woaded colours.
Superior black cloth, wool-dyed and woaded colour.
Common wool-dyed black cloth.
- 49 YORK & SHEEPSHANKS, *Leeds*—Manufacturers, Dyers, and Finishers.
Woaded wool black; second woollen cloth. Piece-dyed black, and piece-dyed black medium, and fast dye.
- 50 GEORGE, T. W., & Co., *Leeds*—Dyers and Finishers.
Worsted lastings in fast black, not woaded, and in various colours.
- 51 WILKINSON, JOHN, *St. Helen's Mills, Leeds*—
Inventor and Manufacturer.
New thin ship sheathing, for placing on the ship's side underneath the copper sheathing; thick ship sheathing for placing between the timbers in building.
Patent padding and wadding for garments; soft white medical cloth, backed with India-rubber, for poultices, or under horse-saddles, &c.; soft white saddle-cloth, without India-rubber.
Gun wadding of first and second quality; haik felt for steam-pipe and boiler covering, and for deadening sound.
Indigo blue pilot felt; indigo blue pilot and brown pilot for great coats.
- 52 WILKINSON, W. & E., *Leeds*—Manufacturers.
Crape, all wool.
Cord, all wool, for summer cloth, manufactured in the worsted manner.
- 54 ROBINSON, THOMAS, *Dewsbury Moor, Dewsbury*—
Manufacturer.
Three-points Mackinaw, super merino, merino bath, and rosed blankets.
- 55 CRABTREE, W., *Dewsbury*—Manufacturer.
Bath blankets, fine, and striped with fancy colours at the ends.
- 56 WHITWORTH, J., & SON, *Earlsheaton, Dewsbury*—
Manufacturers.
Two horse blankets.
- 57 STEAD, WALTER, & Co., *Leeds*—Manufacturers.
Superfine broad-cloth, and wool-dyed woaded black. Sample of fine German wool.
- 58 HALEY, J., & SON, *Bramley, near Leeds*—
Manufacturers.
Woollen cloths, made in the white.
- 59 HALEY, A. & C., *Bramley, near Leeds*—
Manufacturers.
Woollen cloths, made in the white.
- 60 PEASE, HEATON, & Co., *Leeds*—Inventors and
Proprietors.
Barège-de-laine cloth, all wool, for dresses; light, even, transparent, and soft.
Saxe-Coburg, Orleans, and other cloths, cotton and worsted, for dresses.
Super quality de-laine cloth, cotton and worsted.
Satin twill, cotton warp and woollen weft, finish of a new description. In colours for dresses; in white for printing. Union, silk arp, and worsted damasks.

- 61 HARTLEY, J., & SON, *Wortley, near Leeds*—
Designers and Manufacturers.
Heather tweed, woaded; and blooming heather tweed, woaded and grained, for shooting-coats, made from Australian wool.
- 62 WEBSTER, THOMAS, *154 Park Lane, Leeds*—
Manufacturer.
Superfine broad woollen cloth.
- 63 WEBSTER, D., *Leeds*—Manufacturer.
Superfine wool-dyed black cloths.
- 64 BRAMLEY WOOLLEN CLOTH COMPANY, *Bramley, near Leeds*—Dyers and Manufacturers.
Specimens of black cloth, wool-dyed, true and common colour.
- 65 GREEN, R. F., & SONS, *Leeds*—Manufacturers.
Orleans cloth, in blacks and various shades.
- 67 GRAY, S., *Calverley, near Leeds*—Manufacturer.
Woollen cloths: drab and blue prunelle livery-cloth. Russian green prunelle habit-cloth.
- 68 CROMACK, JOHN JUDSON, *Leeds*—Manufacturer.
Woaded and fast black cloth, suitable for the home market—exhibited for superior manufacture and finish.
- 69 FENTON, WILLIAM, *Eccleshill, near Leeds*—
Manufacturer.
Billiard-cloths, green, crimson, and scarlet.
- 70 ELLIS, JOHN W., & Co., *12 Upper Albion Street, Leeds*—
Manufacturer.
Samples of cloth, saved list indigo blues all wool, and a frieze with cotton warp and Australian wool.
- 71 WOODHOUSE, JOHN, *Holbeck Moor Side, near Leeds*—
Manufacturer.
Cloth, woollen weft and cotton warp, fast colour blue; Cloth, common colour, black.
- 72 BEAUMONT, WILLIAM, *Crawshaw House, Pudsey, near Leeds*—Manufacturer.
Black cloths, made both from Sydney and Saxony wool, piece dyed.
- 74 MIDDLEBROOK, JOHN, *Birstall, near Leeds*.
Superfine cloth flannel, of extra width, and of the natural colour of the wool; specimen of coarser quality.
- 75 SYKES, DAVID, & Co., *Leeds*—Manufacturers.
Black milled cloth.
- 77 GILL & BISHOP, *Leeds*—Manufacturers.
Brown, gentian, drab, and black mohair.
- 78 YEWDALL, WILLIAM, & SON, *Rawden, near Leeds*—
Manufacturers.
Woollen cloths of different qualities, viz., Spanish stripes, grey list ladies' cloths, and medium cloths, of different qualities; milled hair-list and double milled hair-list cloths.
- 79 WALKER, J., & SONS, *Millshaw, near Leeds*—
Manufacturers, Dyers, and Finishers.
Single and milled cassimeres figured and coloured.
- 80 SMITH, WILLIAM, *Batley, near Dewsbury*—
Manufacturer.
Wool-dyed indigo blue Whitney. Indigo blue pilot cloth. Green and white mixture, napped pilot. Logwood blue pilot.

- 81 SHEARD, M., & SONS, *Batley, near Dewsbury*—Manufacturers.
Lodged blue pilot cloth. Blue mixture, steel mixture, and Oxford mixture Petershams.
- 82 JUBB, J., & SONS, *Batley, near Dewsbury*—Manufacturers.
Wool-dyed blue Witney cloth; blue pilot cloth; and brown pilot cloth. Woollen fabric with cotton lining thrown on the back, being a new combination of materials. Blue pilot cloth, piece dyed.
- 83 WILSON, DAVID, *Batley, near Dewsbury*—Manufacturer.
Indigo blue pilot cloth.
- 84 WEBSTER, A., *Abbey Mill, Kirkstall, Leeds*—Manufacturer.
Superfine woollen cloths.
- 85 HUDSWELL, J., & SON, *Batley, near Dewsbury*—Manufacturers.
Fancy wrapper for travelling; and fancy lining for overcoats, &c.; made entirely of English wool.
- 86 BROOKE, JOHN, & SONS, *Honley, near Huddersfield*—Manufacturers.
Specimens in each stage of the manufacture of broad woollen cloth. Assortment of broad woollen cloths of various colours, quality, and substance.
- 87 WALKER, JOSEPH, & SONS, *Huddersfield*—Manufacturers.
Brown, black, and grey buffalo.
Black alpaca, lavender mohair.
Blue and white mixed mohair. Black mixture mohair. Low black mohair.
Brown, black, green, royal blue, scarlet, drab, and claret mohair.
Grey mixed alpaca. Yellow mohair heading. Dog-hair cloth.
All for ladies' cloaks and men's over-coats.
- 88 TAYLOR, JAMES, *Meltham, near Huddersfield*—Manufacturer.
Fancy woollens.
- 89 LEAROYD, EDWARD, *Huddersfield*—Manufacturer.
Specimens of cashmere merinos, used for ladies' boot tops.
- 90 SHAW, PETER, *Lockwood, Huddersfield*—Manufacturer.
Woaded black broad woollen cloths.
- 91 PEACE, AARON, & CO., *Clayton West, Huddersfield*—Manufacturers.
Silk chiné dress. Silk and wool dress.
- 92 GREEN, J., *Huddersfield*—Manufacturer.
Various specimens of linseys.
- 93 HINCHLIFFE, JOHN, & SON, *Newmill, near Huddersfield*—Manufacturers.
Woaded mixed doeskin, and mixed durables, exhibited for cheapness and utility.
- 94 KENYON, JONAS & JAMES, *Dogley Mills, Huddersfield*—Manufacturers.
Woollen Silesian stripes for gentlemen's dress.
- 95 BENNETT, JOHN & ABRAHAM, *Bradley Mills, near Huddersfield*—Manufacturers.
Black Venetian cloth, manufactured from superfine Prussian wool. Registered black Lahore cloth, from Cashmere wool. Double Napier cloth, one side wool, the other from the goat of Cashmere, and one side wool; the other from the goat of South America, known as Vicuna wool.
- 96 HEBBLETHWAITE & LISTER, *Market Place, Huddersfield*—Designers and Manufacturers.
Specimens of (all wool) elastic elephanta ribs, for trousers, &c.
- 97 CROSLAND, WILLIAM & H., *Huddersfield*—Manufacturers.
Woollen fancy pantaloon cloths, new designs and improved elasticity.
- 98 SHAW, JOHN, WILLIAM, & HENRY, *Victoria Mill, Huddersfield*—Manufacturers.
Woaded wool-dyed, black, broad, and superfine cloth. Piece-dyed black cloth and prunelle. Wool-dyed black doeskin and cassimere; and rifle broad cloth and wool-dyed Oxford broad cloth.
- 99 MIDGLEY BROTHERS, *Huddersfield*—Manufacturers.
Super Angola mixtures for trousers.
- 100 HASTINGS BROTHERS, *Huddersfield*—Manufacturers.
Cloths—mediums, milled and double milled, or treble milled. Doeskins. Cassimeres.
- 101 WRIGLEY, JOHN, & SONS, *Huddersfield*—Manufacturers.
Claret, olive, steel-mixed, green, and light-blue livery cloths.
Bright blue cloth, for carriage linings.
- 102 VICKERMAN & BEAUMONT, *Huddersfield*—Manufacturers.
Black broad cloths, cassimeres, and doeskins, piece-dyed, permanent colour and finish.
- 103 ARMITAGE BROTHERS, *Huddersfield*—Importers and Manufacturers.
Woaded black elephant beavers, 55 inches wide, great weight, 46 and 44 ounces to the yard, manufactured entirely from Port Phillip wool.
Albert check, requiring no lining for the coats, one side being a plain colour, the other checked.
Albert cloth, the two sides being different colours.
"Exhibition" cloths, 56 inches wide, weighing only twelve ounces to the yard.
Scoured Sydney skin wool, grown in New South Wales, and washed by J. T. Armitage and Co., of Sydney.
- 104 LOCKWOOD, JOSHUA, & KEIGHLEY, WILLIAM, *Huddersfield*—Manufacturers.
Specimens of patent woollen cords, velvet and leather cloths, chiefly for trousers.
- 105 BARNICOT & HIRST, *Huddersfield, Wilsham, and Meltham*—Manufacturers.
Buckskin, Orleans, crape and fancy doeskin, and hair-line for trousers, made from middle-price colonial (Port Phillip) wool.
- 106 BARBER, J., & SONS, *Holmfirth, near Huddersfield*—Manufacturers.
Drab kersey for trousers or coats.
- 107 HOLMES, J., & SONS, *Scholes, near Holmfirth, Yorkshire*—Manufacturers.
Woaded black doeskin and Vienna.
- 108 MALLINSON & SONS, *Huddersfield*—Manufacturers.
Wool-dyed black doeskins, exhibited as specimens of manufacture and finish.
- 109 BEARDELL, ISAAC, & CO., *Thongsbridge, near Huddersfield*—Manufacturers.
Woaded black broad coating, steel broad coating, and black Venetian coating, manufactured of colonial wool grown by the Australian Agricultural Company.
Woaded black broad single-milled coating, manufactured of a picklock, selected from a Silesian prize wool. Black

and blue broad coating, sheep-wool face, alpaca-wool back; blue coating, royal blue back and green back. Fancy woollen trouserings, three-fold cloth wove, treble-milled, and double-faced. Fancy woollen trouserings. Woaded black face, blue Berlin wool back; double-faced; woaded steel, &c.

110 SHAW, SON, & Co., *Huddersfield*—Manufacturers.

Woollen cloths:—Black superfine broads; fancy coatings.

Fancy trouserings; reversible cloth.

Pattern cards of fancy goods.

111 TAYLOR, J., & SON, *Newsome, Huddersfield*—Manufacturers.

Fancy waistcoatings, wool, silk, and cotton; and woollen trousseurs' goods (best Angolas); and woollen shawls and scarfs. Ladies' and children's dresses.

112 JOHNSON, JOHN, *Lockwood, Huddersfield*—Dyer.

Floss-yarns in various shades.

113 DAY, J., & SON, *Mold Green, Huddersfield*—Manufacturers.

Merinos (cotton chain shot with woollen), used chiefly for the tops of ladies' boots.

Cashmerettes, cotton shot with woollen and silk shot with woollen; used for summer over-coats.

114 WILLOT, WILLIAM, & Co., *Huddersfield*—Manufacturers.

Woollen goods, viz., drab livery, kersey. Waterproof drab Devon kersey. Extra treble kersey. Woaded wool-dyed black cassimere; and wool-dyed black doeskin.

115 SCHWANN, F., *Huddersfield*—Merchant.

Fancy vesting called valencias or toilinetts, and quiltings. Fancy pantaloons stuffs. Fancy dresses for ladies and children. Cassinets, cashmerettes, summer paletots, and merinos. Shoe and boot fancy cloths. Summer-coat and paletot articles. Woollen beavers, pilot cloths, and napped Petershams. Tweeds. Plaids and checks. Buckskins, doeskins, fancy woollen pantaloons and over-coat stuffs, composed of mohair, alpaca, and Vicuna. "Elephant and rhinoceros" skins. Friezed coatings. Shawls. Mohair headings.

Plain woollen cloth. Red paddings. Carpets. Grams, barracans, twilled summer cloths. Printed paramattas and merinos. Woollen blankets and horse-covers.

Specimen of ornamenting and lettering the show-end (nead-end) of woollen cloths, kerseymeres, &c.

116 TOLSON, J., & SONS, *Dalton, Huddersfield*—Manufacturers.

Waistcoatings, comprising figured quiltings, shawl cashmeres, Persian velvets, beavers, low vestings. Trouserings. Challi wool plaids for children's dresses for spring and for winter.

117 WRIGLEY, J. & T. C., *Huddersfield*—Manufacturers.

Moscow beaver, two faces, different colour and finish. Moskitto, two faces, different colour and different material. Janus, nap-face, beavered and Witney, and checked back. Partridge mixture, for shooting-coats. Reversible cloth, finished on both sides. Stockinette, or tricot. Fancy trouserings.

118 SYKES & OGDEN, *Huddersfield*—Wool-cleaners and Inventors.

Drawings illustrative of patent and improved wool-cleaning machine, which will clean 50 lbs. of wool per hour.

Burry and motey wool, with the same cleaned from the burs and motes; and specimens of burs and motes as taken from the wool by the machine, cleaned, and brought into a good state.

119 HINCHLIFF, J. & G., *Huddersfield*—Manufacturers.

Drab kersey, ordinary milled and Devonshire waterproof.

Black and steel doeskins; Oxford and mixture doeskins.

Various fancy woollen trouserings.

120 BEARDSSELL, CHARLES, & SON, *Holmebridge, Huddersfield*—Designers and Manufacturers.

Woollen pantaloons, plain and fancy.

121 STARKEY, J. & A., *Sheepridge, Huddersfield*—Manufacturers.

Drab woollen cords. Drab thickset constitution. Fancy, plain, and woollen velveteens.

122 COWGILL, JESSOP, & Co., *Huddersfield*—Manufacturers.

Cashmerettes for coats and ladies' boots.

123 HUTH & FISCHER, *Huddersfield*—Merchants.

Plain and striped Franklin coatings, wool face.

Mohair back double Queen's cloakings.

Mohair back pantaloons.—Registered.

124 CLAY, J. T., *Rastrick, Huddersfield*—Manufacturer.

Woollen trouserings, blue and white angolas; the blue being a pure indigo dye. Manufactured from fine Saxony wool; from Australian wool; and sundry varieties.

Waistcoatings in woollen and silk; and of fine worsted yarn, cotton and silk.

Union cloth, composed of woollen and cotton. Vicuna cloth.

125 SCHOFIELD, JONATHAN, *Rastrick, near Huddersfield*—Manufacturer.

Fancy woollen trouserings, different patterns, and woollen and cotton, mixed.

Silk, woollen, and cotton waistcoatings, in different colours of buffs, drabs, &c.

Patent British cashmeres, all wool, different colours.

Fancy bed furniture in wool and silk, and in wool, silk, and cotton.

Fancy dresses in wool and cotton, &c.

Fancy shawls, all wool, and wool and cotton.

126 NORTON, JOSEPH, *Clayton West, Huddersfield*—Manufacturer.

Summer shawls and coatings. Registered winter woollen shawls, unique; and novelty, having four distinct patterns or appearances in one shawl. Union shawls. Registered goods for dresses, waistcoatings, and cloakings. Table covers. Woollen, alpaca, and rabbit's down glove-cloths. Registered fancy woollen trouserings. Stockinette trouserings. Crochet counterpane.

127 OLDFIELD, ALLAN, & Co., *Lockwood Mills, and Huddersfield, Yorkshire*—Manufacturers.

Specimens of the various stages of the fancy woollen manufacture, from the wool to a warp prepared for the loom; also pattern ranges of fancy woollen trouserings, from the loom to the finished cloth, with a drawing of Oldfield's patent machine for piecing woollen cardings.

Fancy broad cloth for overcoats.

Fancy doeskin trousering, and fancy crape trousering. Made from fine wool. Exhibited for their manufacture.

Black and brown twist checked tweed, made from waste, &c., without any wool.

Black, brown, and white twist checked tweed, made from waste, &c., without any wool.

128 HOADLEY & PRIDIE, *Halifax*—Manufacturers.

Damasks, for furniture purposes, of different qualities and colours, manufactured of silk, cotton, and wool, either separately or in combination.

129 BROWN, WILLIAM, *Halifax*—Manufacturer.

Damasks:—Cotton and worsted, yarn and piece dyed; cotton, silk, and worsted; silk and worsted.

Table covers:—Cotton and worsted, yarn dyed; cotton, silk, and worsted; worsted.

130 AKROYD, JAMES, & SON, Halifax—Spinners and Manufacturers.

Table-covers:—Cotton and worsted, and silk and worsted.

Damasks:—All worsted; cotton and worsted, yarn and piece dyed; silk and worsted, and with silk swivel figure.

Articles for ladies' dresses:—Silk and cotton; silk and worsted; silk, worsted, and cotton; worsted and cotton.

Plain goods, all worsted:—Serges de Berry, lastings, princettas, crapes, plain-backs, camlets, shalloons, wild-bores, full twills, alepinas, merinos, Says, East India camlet, long ells.

Plain goods, worsted and cotton:—Union serges de Berry and lastings; cotton warp princettas and full twills; Orleans, lustres, Coburg, cotton warp says, linings.

Worsted and cotton gambroons, for trousering.

Ponchos:—Plain and brocade, striped; aravenas, Vi-
cunas.

Yergas, for horse-covers.

Yarns:—Single, two-fold, and four-fold carded yarns; single, two, and four-fold combed; single, lustre and damask weft; single warp; two-fold camlet warp and weft; two-fold lasting warp; two and three-fold Genappe.

130A. ECRÖYD, WILLIAM & SON, near Burnley—Manufacturers.

1. Power-loom Coburg cloth (mixed fabric, cotton and wool, for dresses); range of qualities.

2. Orleans cloth, similar fabric.

3. Saxony Orleans cloth (mixed fabric, cotton and wool), for dresses, differing from No. 2, only in being of a soft instead of bright and sharp texture.

4. Mousseline de laine (mixed fabric, cotton and wool), for dresses; range of qualities, printed and dyed.

5. Power-loom Saxe Coburg cloth, made from cotton and wool; a new fabric, of light texture, with a range of qualities.

6. Power-loom Barège de laine, made from cotton and wool; range of qualities, printed and dyed.

7. Bunting for ships' colours and railway signals, made by power-loom; all wool.

8. Worsted heald or heddle yarn, range of qualities, spun, and twisted, and singed (to deprive it of loose fibre), by power; it is used in the weaving of cotton, worsted, woollen, silk and flax fabrics, to effect the movement of the warp threads during weaving, for which it is required to be strong, smooth, and even.

9. Worsted genappe chord, prepared as in No. 8, and used in the manufacture of braids, fringes, &c., its smoothness enabling it to be well combined with silk; range of qualities.

10. Worsted press bagging, used for making bags, in which linseed, rape-seed, &c., are crushed to extract the oil. It is therefore required to be strong and durable, and not to mat together or felt, which would prevent the oil from passing through it.

131 SHEPARD & PERFECT, Cross Hills Mill, Halifax—Manufacturers.

Cotton and worsted, all worsted, and silk and worsted damasks.

Silk and worsted and cotton and worsted Victoria velvet damasks.

Silk and worsted and cotton and worsted Victoria velvet table-cover.

Plain and brocade striped worsted poncho.

All the patterns are registered.

The manufacturers express their opinion that the Victoria velvet damask and table-cover, are in a style that has not been previously made in this country.

The article poncho is used by the natives of certain parts of South America as a cloak, or outer garment. The required length, when cut from the piece, has a slit made in it, for the head of the wearer to pass through.

133 BARRACLOUGH, WM., & SON, Halifax—Manufacturers.

Samples of woollen cloths:—Scarlet, green, yellow, and Indigo blue, striped; and scarlet white list; crimson and drab druggets; red union paddings, two kinds; super red cloth paddings; brown, dark and light grey kerseys; blue linsey; fancy warp tweed; green, red, crimson, and blue printed linseys; white house cloth; crimson and green embossed table covers. Exhibited for cheapness of production and general utility.

134 WARD, JOHN WHITELEY, Halifax—Manufacturer.

Cotton and worsted damasks, yard-dyed, fast colours; woven in the power-loom, with Jacquard machine.

Worsted damask, ingrain colour, and ingrain crimson, with borders, for draperies.

Victoria table-cloth, made from cotton and worsted, dyed previous to weaving, fast colours.

135 M'CREA, H. C., Halifax—Manufacturer.

Furniture damasks, piece and yarn dyed. Cotton and worsted; all worsted; silk, worsted, and cotton; silk and worsted; and cotton and worsted, Geneva.

Table-covers. Cotton and worsted; silk and worsted; and silk and woollen, yarn-dyed. All registered.

Poncho stuffs, all worsted, used in South America.

136 CLAY, J., & SONS, Halifax—Manufacturers.

Linsey, for masons and carpenters' jackets. Plaiding, for drawers. Cricket jackets. Raised kersey. Milled kersey, for colliers' and excavators' smocks and coats. Fearnought, for draymen's coats. Blue flannel, for colliers and sailors' shirts, &c. Galway or Irish flannel. Ironing blanket.

137 AKED, J., & SONS, Halifax—Manufacturers.

Pantaloons, plain cotton and worsted, yarn and piece dyed. Fancy checks, yarn dyed.

Mixture coatings, cotton and worsted, yarn and piece dyed. Plain lastings, and super worsted crapes, all wool. Cashmeres, cotton and woollen.

138 WILSON, JOHN, Forest Cottage, Ovenden, near Halifax—Manufacturer.

Ponchos, Mantuas, and shawls; in woollen, cotton, and worsted.

139 SALT, TITUS, Bradford, Yorkshire—Manufacturer.

Alpaca manufactures:—Goods made from alpaca, with cotton-warp, dyed in the piece: alpaca lustres, black, various qualities; coloured and chameleon, in three qualities; alpaca Coburgs, black and coloured, various qualities; figured alpaca lustres: twilled alpaca lustre linings, black, coloured, and various qualities; serge alpaca lustre linings, black, various qualities; coloured plain twilled and satin alpaca mixtures; coloured satin alpaca lustres.

Goods made from alpaca, in its natural colours, with cotton-warp mixtures: plain and twilled mixtures, and Croton coatings, various qualities.

Goods made from alpaca, with silk-warp, dyed in the piece: Silk-warp alpaca lustres, black, coloured, and chameleon, various qualities; figured silk-warp alpaca lustres, chameleon, various qualities.

Goods made from alpaca, in its natural colours, with silk-warp: alpaca mixture poplins; poplins, plain colours; Chiné poplins; satin-striped mixture poplins; silk checked poplins; chameleon silk-warp figured alpaca lustres; silk-warp summer coatings.

Goods made from alpaca, with warp composed of silk and cotton, dyed in the piece: alpaca Incas, colours; figured Amazonians, colours; figured silk-striped alpaca lustres, colours; satin-striped alpaca lustres, black; umbrella cloth; alpaca Madelinas, colours.

Goods made from alpaca, in its natural colours, with warp composed of silk and cotton: satin-striped alpaca mixtures; parasol cloth; figured alpaca amazonians; alpaca Madelina.

Specimens of British alpaca wool, grown by the Earl of Derby.

Specimens of alpaca wool, from the west coast of South America.

Alpaca wool combed. Alpaca yarns.

Mohair manufactures:—Goods made from mohair, with cotton-warp: serge linings, black and colours, various qualities, dyed in the piece; chameleons, chinés, and gauze chameleon, yarn-dyed.

Goods made from mohair, with silk-warp, yarn-dyed: chiné, and chameleon poplins; figured mohair amazons, gauze chameleon and satin-striped.

Specimens of mohair; also combed and in the yarns.

Moreens made from English and Russian wool, various qualities.

Specimens of Russian wool; also combed and in the yarns.

[The alpaca is an animal of the Llama tribe, inhabiting the mountain-region of Peru. The wool or hair is of various shades of black, white, grey, brown, &c., and is remarkable for brightness and lustre; great length of staple, and extreme softness. This wool was brought into general use in this country about 16 years ago by the present exhibitor. Since that time the various obstacles in the way of its successful working have been quite overcome, and the alpaca manufacture now ranks as one of the most important branches of the Bradford worsted stuff trade. The articles produced from alpaca in combination with silk are especially noticeable for their softness and brilliancy. The bulk of the goods, however, are made with cotton warp, and when dyed and finished approach in lustre very nearly to silk. The following is the average yearly importation of alpaca wool into England since its first introduction, viz.: from 1836 to 1840, 7,000 bales per annum; from 1841 to 1845, 13,000 bales per annum; from 1846 to 1850, 20,000 bales per annum. It is generally believed that this last amount is the utmost extent of production in Peru.

The animal has not hitherto been very extensively cultivated in this country. H. R. H. Prince Albert has a small quantity at Windsor Park, and the Earl of Derby has a flock of about 60 at Knowsley. A specimen of Lord Derby's growth is now exhibited by Mr. Salt. Considerable difficulties have arisen in the rearing of these animals in England; but when more correct information is obtained as to their habits in their native district, these will most probably be overcome. Attempts are just now being made to introduce the alpaca into our Australian colonies, where the climate, from its great dryness, is believed to be congenial for its successful naturalization.

Mohair or goat's wool is produced exclusively in Asia Minor. In its raw state it is superior in lustre to alpaca, and is wrought into many beautiful fabrics. The importation of this article has increased from 5,621 bales in 1841, to 12,884 bales in 1850. Mohair yarn is largely exported to the Continent, where it has superseded the yarn formerly spun in Turkey, and is there manufactured into Utrecht velvet for hangings, furniture, lining of carriages, &c., a branch of trade which is now gaining ground extensively in this country.

Russian Donsky fleece wool is of a very coarse description, and was first combed and brought into use in the worsted trade about 20 years ago by the present exhibitor.—G. T.]

140 MILLIGAN, WALTER, & SON, *Harden Mills, Bingley, Yorkshire*—Manufacturers.

Embroidered alpaca and silk furniture-cloths, and dress goods; satin-striped dress goods; damasks; manufactured by a patent process.

Alpaca program coatings.

Coatings, worsted, cotton, silk, &c. Mohair mixtures.

Specimens illustrative of the processes of the Alpaca and mohair manufactures, viz:—

Fleece of alpaca wool from Peru, and a superior fleece of mohair or goat's wool from Turkey. The same sorted into five distinct qualities for the wool-comber. The same on the wool-combs, showing the "sliver" or long fibre of quality, No. 4, used in the embroidered alpacas, exhibited as above, and the "noil" or portion of wool left on the comb after the sliver is drawn off, and which is used for making heavy cloths, ladies' mohair cloaks, &c. The same in the various stages of preparation and spinning until reduced to yarn on the spool or weaver's bobbin.

141 SCHWANN, KELL, & Co., *Bradford*—Proprietors.

Worsted merinos, lastings, serge de Berry, satin serge, says, figured Russells, velillos, cristales, cubicas, and alepinas. Silk-warp Coburgs; double-twill; plain and figured Russells, and alpaca lustres; dyed in the piece, in various colours. Silk-warp mixed alpacas, grey weft—natural colour of the wool. Cotton-warp Coburgs; ditto, double-twill; plain and figured Russells; Orleans; demi, alpaca, mohair, and twilled alpaca lustres; says; linings, worsted weft; linings, mohair weft; figured Orleans; plain and figured satins: dyed in the piece, in various colours. Cotton-weft lastings and serges de Berry; silk-weft and linen-weft lastings and serges de Berry: dyed in the piece, in various colours. Silk and cotton dresses, dyed in the yarn. Cotton and worsted black and white checks; cotton and worsted fancy dresses; cotton, worsted, and silk dresses. Cotton and wool plaids.

142 ROGERS, G., *Bradford*—Manufacturer.

Cobourg cloth of fine quality: silk and cotton warp.

143 FOSTER, J., & SON, *Black Dike Mills, near Bradford*—Manufacturers.

Goods made of cotton warp and alpaca weft; of cotton and silk warp, and alpaca weft; of silk warp and alpaca weft, and of cotton warp and mohair weft; crapes, silk striped and others; gros-de-Berlins, figured and others; alpaca coatings in various qualities, and varieties of shade; twilled alpaca silk checked fancy coatings; vestings; chiné; damasks. Alpaca, mohair, and worsted yarns. Dyed by Mr. Joseph Holdsworth, Wakefield.

144 JOWETT, THOMAS, & Co., *Bingley, near Bradford, Yorkshire*—Manufacturers.

Cotton warp, and alpaca weft, dyed black.

Cotton warp, and dyed silk warp, and alpaca mixture weft, natural colours.

White silk warp, and brown and black alpaca weft, natural colour.

White and dyed silk warp, and black silk warp.

Dyed silk warp, and black alpaca weft, figured, natural colour.

Dyed silk warp, satin faced, and black alpaca weft; dyed silk warp, figured, with black alpaca weft, suitable either for vestings or dresses.

Cotton warp, plain and figured silk stripe, with alpaca mixture weft.

Dyed silk warp, and dyed linen weft.

Dyed silk warp, and silk weft, figured, and white silk warp, and China grass weft, figured, for vestings.

145 HARRIS & FRISON, *Bradford*—Manufacturers.

Circassian cloth: the weft is a combination of the finest wool and silk, which produces the glossy surface it exhibits.

Cloth woven from the hair of the Angola rabbit.

146 ARMITAGE, GEORGE, & Co., *Bradford*—Dyers.

Orleans, Coburg, and Brazilian cloth; mohair, silk and mohair, and silk and alpaca figures, of various qualities and colours, plain and shot. Exhibited as specimens of dyeing.

147 TREMEL, A., & Co., *Bradford*—Manufacturers.

Plain alpaca lustres and chameleons; plain chameleons, worsted weft; plain fancy stripes and check; plain satteens and alpaca weft; figured Orleans; alpaca lustre figures; twilled satteens and figures; figured Circassians, stripes, and checks, all in cotton warps and piece dyed.

Madonnas, or mixed alpaca lustres, natural colours, silk warp alpaca lustres, plain, stripes, checks, and figures, in natural colours and piece-dyed.

Plain mohair chameleons and Barèges; fancy coloured silk stripes and checks; printed warp, Chinese fancies and checks; silk figures and stripes; and checks, all made of dyed materials.

Mixed alpaca coatings, natural colours.

148 RIPLEY, EDWARD & SON, *Bradford, Yorkshire*—Dyers.

Orleans cloths and Coburg cloths, dyed from white warps.

French de laines and merinos.

Ombre damasks, and alpaca and balzarine brocades, produced by a patented process.

Damask table-covers.

Plain balzarines, dyed from white warps.

All exhibited as specimens of dyeing, &c.

[The business of the worsted-stuff dyer was formerly confined to the comparatively simple process of dyeing goods composed entirely of wool. The introduction of cotton warps in 1834, with various combinations of silk subsequently produced, rendered necessary more varied and intricate chemical processes, in order that a fabric composed of both vegetable and animal substances might be made to receive an equal and regular dye. The large increase of the Bradford trade is, in a great measure, attributable to the energy and skill of the dyers, by whom this object has been accomplished so effectually, that goods made of white cotton warp and worsted weft can be dyed almost, if not quite, as perfect in colour as French merinos composed of wool alone. Some idea of the amount of worsted goods, dyed and finished, may be formed from the fact that the three largest dyeing establishments in Bradford can each turn out about 12,000 pieces weekly; in addition to which there are many dye-establishments in neighbouring towns principally supplied with goods from Bradford.—G. T.]

149 CRAVEN, J., & SON, *Prospect Mill, Thornton, near Bradford*—Manufacturers.

Lustre Orleans, in different qualities, blacks and colours.

150 DRUMMOND, J., *Bradford*—Manufacturer.

Mixed fabrics, composed of cotton, alpaca, and silk, plain and figured, for vestings, dresses, &c.

151 CLOUGH, R., *Bradford*—Manufacturer.

Specimens of merinos, all wool, various qualities.

152 DALBY, JAMES, *Bradford*—Manufacturer.

Specimens of figured bombazines; figured and plain silk crapes; silk stripes and checks; figured worsted crapes and chinés; figured and plain alpaca lustres, alpaca and other mixtures; alpaca and worsted figured cloakings and linings; plain and figured Orleans and Coburgs; single and double twill. Dyed by Messrs. Ripley & Son.

153 CRAVEN & HARROP, *Bradford*—Manufacturers.

Coburg cloths, black and colours, in various qualities. Paramatta cloths, black. Full-twill cloths, with silk, worsted, and cotton warps. Shawl cloths, in various widths and makes.

Merino and Orleans cloths, black and colours. Alpaca cloths, black. Aprons, black. Moreens, black and colours. Union and worsted damasks.

Canton cloths. Linings and serge cloths, black. Fancy goods, in various styles. Alpaca mixtures, in various qualities and natural colours.

155 HAGGAS, WILLIAM, & SONS, *Keighley*—Manufacturers.

Samples of Orleans, lustreen, worsted lining, and mohair.

156 SHUTTLEWORTH, WILLIAM, & Co., *North Bierley, near Bradford*—Worsted-spinners and Manufacturers.

1. Piece of plain fustian.	8. Silk stuff—mourning.
2. Low figured Orleans.	9. Low plain mixture.
3, 4, 5. Figured silk stripe.	10. Shot silk stripe.
6, 7. Fancy figured silk stripe.	11. The same checked.
	12. Fancy figured Orleans stripe.

157 CLAPHAM, JOHN, *Bradford*—Manufacturer.

Net, cotton warp, and alpaca weft; net, cotton warp and worsted weft; Coburg cloth, cotton warp and worsted weft; diagonal lining, cotton warp and alpaca weft.

158 CLAPHAM, WILLIAM, *Wilsden, near Bingley, Yorkshire*—Manufacturer.

Coburg cloths, of various qualities and colours.

159 WALL, COCKSHOT, & WALL, *Linton Mills, near Skipton, Yorkshire*—Manufacturers.

Shaded tapestry ground, with various coloured silk figure, and bright varied shades in wool for dresses.

Shot and printed ground Orleans, with coloured silk stripes.

Fine Orleans cloth, in new colour, from a combination of various wools.

Preparations of worsted yarn.

160 MORTON, DAVID, *Baldon, near Bradford*—Manufacturer.

Ends of union tweeds. Cotton warp and woollen weft.

161 KERSHAW, S. & H., *Laisterdyke, near Bradford*—Manufacturers.

Black Orleans cloths, of various qualities.

162 TOWNEND BROTHERS, *Cullingworth, near Bradford*—Manufacturers.

Worsted heald yarns, various folds; worsted genappe yarns, and of various degrees of twist; mohair poplin; worsted and mohair and alpaca yarns; mixed mohair and alpaca yarns; worsted weft and warp yarns.

163 SEMON, SILTZER, & Co., *Bradford*—Proprietors.

Orleans cloth, manufactured by Chapman & Whitaker, Baldon, near Bradford; dyed by J. M. Kirk, Halifax.

Orleans cloth, manufactured by William Lund, Keighley; dyed by J. M. Kirk.

Orleans cloth, lustres, and mixed lustres, manufactured by J. & R. Turner, Horton, near Bradford; dyed by J. M. Kirk.

164 PEEL, WILLIAM, & Co., *Bradford, Yorkshire*—Manufacturers.

Coburg cloths of various qualities and colours.

Silk warp paramattas, Brazilians, and silk warp double twills, blacks.

165 BOTTOMLEY, MOSES, & SONS, *Shelf, near Halifax*—Designers and Manufacturers.

Figured Angora, composed of mohair and silk, for ladies' dresses.

Figured Genoa lace. The pile has not before been produced in stuff goods.

Figured gauze lace, composed of mohair and silk.

Figured mohair lustre, in different qualities and patterns, &c.

Figured Orleans, in different qualities, &c., composed of worsted and cotton, for dresses, &c.

Mohair serge, in various patterns and qualities, for coat facings, &c.

Orleans serge, for coat facings, &c.

Mohair lustre, plain, composed of mohair and cotton, of various qualities.

165A **HOLDSWORTH, JOSEPH, Wakefield**—Dyer and Finisher.

Pieces of stuff, mixed fabric of cotton and worsted, and cotton and mohair, figured and plain; exhibited as specimens of dyeing.

166 **HOLDSWORTH, JOHN, & Co., Halifax, Yorkshire**—Manufacturers.

Crimson merino and green durant, for lining rich damasks. Black and white cotillion for ladies' skirts.

Printed Tournays, registered patterns, used for furnitures.

Green and gold, crimson, buff, blue and gold, gold and white, and gold silk and worsted damask.

Crimson and gold, blue and salmon, and crimson, green, and gold yarn-dyed damask.

Blue, giraffe and white, crimson, green, and morone, and blue and salmon yarn-dyed damask.

Green and white and drab and white union damask.

Giraffe and white, blue and white, Ponceau and white, fawn and white, and gold and white union damask, all registered designs for furnitures.

Scarlet, drab, giraffe, Ponceau, sea-green, fawn, blue, rose, crimson, green, morone, and buff worsted damask for furnitures. Ponceau and sea-green Turkey cloth damask.

Green and gold, green, crimson, crimson and gold, green, salmon, and white, blue and gold (silk) yarn-dyed Turkey cloth damask.

Royal blue and buff, crimson and gold, crimson, morone, and gold, crimson, gold, and white silk and wool damask. Green and Ponceau merino curtain, quite new, all for furnitures.

Albert, Victoria, merino, and silk and wool table covers; registered patterns.

Crimson, scarlet, drab, and Ponceau watered moreen, for furnitures.

Coburg and Orleans cloths for ladies' dresses. Black lining for coats. Damask aprons. Merino damask.

Serge de Berri, union, worsted, and silk lasting for buttons.

167 **SUGDEN, J., & BROTHERS, Dockroyd Mills, near Keighley, Bradford**—Manufacturers.

Plain and striped calimancoes; strong worsted merino, union, and princetta says; strong union, and merino shalloons; merinos; cubicas; summer cloths, double twill; union princettas; bombazet; worsted heald yarns; worsted genappes; mohair and alpaca genappes; 800 specimens of yarns, used in the manufacture of poplins, &c.

168 **MILNER, J., & Co., Clayton, near Bradford**—Manufacturers.

Orleans. Worsted weft and cotton warp, in different colours.

169 **CLARK, J., 56 High Street, Bradford**—Manufacturer.
Table cloth, embroidered with thread on crimson sarsenet.

170 **SLATER, HENRY, Yeaddon, near Leeds**—Manufacturer.

Woollen netting, used by gardeners for the protection of the bloom of fruit-trees from frost.

170A **NICHOLSON, JOHN, Bradford**—Manufacturer.

Specimens of cards.

171 **ROBERTS, H., Bradford**—Manufacturer.

Grogan coatings.

172 **TETLEY, Mrs., Bradford**—Producer.
Embroidered quilt.

173 **RAND, JOHN, & SONS, Bradford**—Manufacturers.

Cobourg cloths, cotton warp, worsted weft, of different qualities, blacks, and colours; Coburg cloths, first quality; and with silk warp; merinos, moreens, and worsted warp and weft, single and double twill. Several of the pieces exhibited are of the finest description of worsted goods ever manufactured.

[The following details will convey some idea of the progress and extent of the worsted stuff trade. Messrs. J. Rand & Sons' factory was built in 1803, and was the third erected in Bradford. The population of the town and neighbourhood was then about 6,500; it is now estimated at 90,000. There are at present in Yorkshire (principally in the parishes of Bradford, Halifax, Keighley, and Bingley), 418 worsted factories, with 746,281 spindles, 30,856 power-looms, and employing 70,905 workpeople. Taking the worsted and woollen manufactures together, the increase during the last 16 years has been, in the number of factories 51 per cent.; in the number of hands employed, 116 per cent.—G. T.]

174 **HORSFALL, J. G., & Co., Bradford**—Manufacturers.

Henrietta cloths, with silk warp and worsted weft.

Fine Saxony cloth, all wool.

Fine Coburg cloth, with cotton warp and worsted weft.

Coburg cloth of various qualities.

175 **TOWNEND, SIMEON, Thornton, near Bradford**—Manufacturer.

Worsted heald, and genappe yarns, spun from British wools; healds, or harness for weaving woollens, worsteds, linens, cottons, &c.; braids, poplins, galloons, cords, &c. manufactured from genappe yarns.

176 **WHITLEY, JAMES, Morton, near Bingley, Yorkshire**—Manufacturer.

Alpaca yarns on spools prepared for weaving.

Mixed alpaca and mohair yarns on spools prepared for weaving, in various colours.

177 **SHARP, DAVID WILKINSON, Bingley**—Manufacturer.

Alpaca yarns on weaving bobbins, prepared by Ross's new process, with improvements.

Mohair yarn on spinning bobbins, two-fold in the hank, and in colours.

Mohair yarn, single in the hank.

Slivers of mohair, combed.

Worsted yarn on weavers' bobbins.

178 **QUITZOW, SCHLESINGER, & Co., Bradford**—Proprietors.

Berlin wool, in various folds and colours, spun and dyed in England.

Flax, produced by the new patent process of Mr. P. Claussen, viz., flax in the straw, showing on the same stems the fibre both unprepared and prepared, and also unbleached, bleached, and dyed various colours; carded flax-fibre, unbleached, bleached, and dyed; heckled flax-fibre, long flax-fibre, unbleached and bleached.

Yarns, spun from the above flax, alone, and mixed with cotton, wool, and silk.

[To the present time it has been considered impossible to apply existing cotton machinery to the manufacture of flax. Mr. P. Claussen considers that this difficulty now no longer exists, and that by processes adopted by him, it is possible to prepare a kind of "cotton" from flax, suitable for a large number of manufacturing purposes, and capable of being spun in tolerably high numbers. A peculiar part of Mr. Claussen's patent is the bleaching of flax and its disintegration, which is said to be effected

in a very short space of time. It is stated that this is done by the chemical force of the disengagement of carbonic acid gas, or the mixture of an acid with the carbonated alkali, in which the flax is steeped.—R. E.]

179 CHEESEBOROUGH, WILLIAM, *Bradford, Yorkshire*—Proprietor.

Specimens, illustrating the average quality of combing wools from each county in England.

Samples of Irish, Scotch, and Welsh long wool.

180 BEHRENS, J., *Bradford*—Manufacturer.

Figured Coburg cloths and satteens, silk and cotton warps.

181 BOTTOMLEY, J., 6 *Cheapside, Bradford*—Manufacturer.

Plain and figured Orleans, embroidered with silk and alpaca, &c.

Saxony cloth, embroidered with gold and silver.

Silk and worsted mixed lustres, embroidered with two colours of silk, in different designs: silk warp and mixed worsted weft. The embroidering is done by machinery, constructed so as to embroider figures in any part of the fabric, and to economise the quantity of silk used in the production of the designs.

182 GREGORY BROTHERS, *Bradford*—Manufacturers.

Mixed fabrics of alpaca and mohair.

183 BAUGHEN BROTHERS, *Banbury*—Manufacturers.

Mohair table-covers. Chinese prints for vestings. Livery plushes. Angora velvet plushes for vestings. Utrecht velvet for furniture and linings of carriages, &c. Mohair in wool top and yarn.

184 PEASE, HENRY, & Co., *Darlington*—Manufacturers.

Specimens of worsted manufacture. Series of samples, showing its various stages, from the fleece to the finished cloth.

Pieces of Coburg cloth, 6 and 7 quarters wide, made of Lincolnshire, Cheviot, South Down, Australian, and Saxony wool, in brown, black, green, royal blue, scarlet, drab, and French grey colours.

Pieces of double twill, 7 quarters wide, made of South Down, Australian, and Saxony wool, in claret, sea-green, and royal blue colours.

All these pieces are used for ladies' dresses.

Pieces of coatings, 7 quarters wide, in very dark blue and black colours. These are used for gentlemen's summer coats.

The letters affixed to the specimens of cloth for ladies' dresses refer to corresponding marks affixed to the patterns of processes in the same case.

This worsted manufactory was established in 1732, and gives employment at present to 1,000 hands.

185 BENNETT & Co., *Abingdon Street, Portland Street, Manchester*—Manufacturers.

Utrecht velvet, for decorations, furniture, upholstery, and carriage linings.

186 KAY, RICHARDSON, & WROE, *Chancery Lane, Manchester*—Manufacturers.

Brocade chene. Chene barège de Valenciennes. Chene Versailles. Barège robe de Verona.

187 DIXON, R. & T., *Galashiels, Scotland*—Manufacturers.

Saxon wool plaids. Specimens of Scotch tweeds.

188 COCHRANE, J. & W., *Galashiels, Scotland*—Manufacturers.

Specimens of Scotch tweed trouserings.

189 SANDERSON & SIBBALD, *Galashiels, Scotland*—Manufacturers.

Scotch tweed trouserings.

190 GILL, ROBERT, *Inverleithen, Scotland*—Manufacturer.

Regimental tartans of the 79th or Cameronians, the 93rd or Sutherland, the 92nd or Gordon, the 71st or Mackenzie, and the 42nd or Royal Highlanders; the "setts" taken from Logan's "Scottish Gael," in a summer fabric of cloth, made of fine Saxony wool, and a shepherd's cloth.

The Royal tartan, the Royal Highlanders, the Mac Kenzie, the Sutherland, and the hunting MacDonald tartans, in fabrics for ladies' dresses, made of Saxony lambs' wool. Specimens of other Scottish fabrics for ladies' wear.

191 INGLIS & BROWN, *Galashiels, Scotland*—Manufacturers.

Specimens of Scotch tweeds.

192 LEES, R. & G., *Galashiels, Scotland*—Manufacturers.

Plaids:—42nd tartan. Mackenzie, Forbes, Frazer, Victoria, Royal Stewart, M'Neil, Gordon, and Shepherdess (large and small check).

Shawls:—Frazer tartan, Royal Stewart, 42nd, Gordon, and Shepherdess.

Cloakings:—Frazer tartan, M'Kenzie, 42nd, Victoria, Royal Stewart, Forbes, and Gordon.

193 CLAPPERTON, T. & G., *Galashiels, Scotland*—Manufacturers.

Scotch Stewart and fancy plaids. Scotch tweeds.

194 BALLANTYNE, HENRY, & SON, *Galashiels, Scotland*—Manufacturers.

Ladies' woollen scarfs or shawls. Woollen tartans for ladies' dresses. Scotch tweeds.

195 SIME, JAMES, & Co., *Galashiels, Scotland*—Manufacturers.

Plaids as worn by the Scotch Highland regiments. Ladies' Scotch plaids, shepherdess and fancy. Gentlemen's royal Stewart plaid. Pieces, Scotch tweed vestings. Specimen of wool and yarn, showing the different stages of manufacture.

196 SANDERSON, R. & A., & Co., *Galashiels, Scotland*—Manufacturers.

Scotch woollen clan and fancy plaids. Gentlemen's plaids.

197 FYFE, ALEXANDER, & Co., 77 *Queen Street, Glasgow*—Manufacturers.

Twelve pieces of new dress fabrics. One dozen fancy cotton shawls; one dozen union shawls.

197A KNOX, A. L., 9 *Cochrane Street, Glasgow*—Manufacturer.

Material for dressing-gowns.

198 RAINEY, KNOX, & Co., 8 *St. Vincent Place, Glasgow*—Manufacturers.

Shawl dresses for robes de chambre, wool and cotton, each $4\frac{1}{2}$ yards long, and 41 inches broad.

199 LAIRD & THOMSON, *Ingram Street, Glasgow*—Manufacturers.

Set of clan patterns in gala cloth.

200 WINGATE, SON, & Co., *Glasgow*—Manufacturers.

Harness woven long and square shawls; printed Barège and cashmere and woven woollen shawls. Woollen goods in the piece.

201 CAMPBELL, J. & W., & Co., 34 *Candleriggs Street, Glasgow*—Proprietors.

Scotch printed goods; texture all wool; viz.:—barège handkerchiefs, British manufacture; cashmere handkerchiefs, French manufacture; square shawls, British and French manufacture.

Grenadine silk shawls, British manufacture.

Fine and super cashmere d'ecosse long shawls, texture all wool, and French manufacture.

- Grenadine, fine and super barège long shawls, ground British manufacture.
- Barège mufflers, on French ground, Scotch printed, and on cotton and wool ground, British manufacture.
- Embroidered square shawls, fabric silk and wool, French manufacture and Scotch embroidery.
- Filled long shawls, Scotch manufacture.
- 202 CROSS, WILLIAM, 62 *Queen Street, Glasgow, and 45 Friday Street, London*—Manufacturer.
- Various Saxony wool shawls; clan, shepherdess, and fancy patterns, square; and long Byzantine style, fancy pattern, pure cashmere; and checked and plain Saxony wool plaid dresses.
- 203 GILMOUR, WILLIAM, & Co., *Glasgow*—Manufacturers.
- Scotch woollen tweed trouserings; Scotch woollen six-quarter Saxony tartans.
- 204 BLACK & WINGATE, *Glasgow*—Manufacturers.
- Samples of cotton yarn, spun by the exhibitors. Raw cotton cloth, as from power-loom.
- Cheapest cotton Scotch lawn handkerchiefs; one dozen fine cotton lawn handkerchiefs. One dozen cheapest and one dozen fine cotton Scotch cambric handkerchiefs. One dozen cheapest embroidered corner cotton handkerchiefs; four handkerchiefs, fine, of the same description.
- Two dozen Scotch cambric handkerchiefs, fancy borders, &c. Scotch cambric handkerchiefs, imitation embroidery, in the loom.
- A piece of fine cotton Scotch cambric. A piece of fine $\frac{7}{8}$ bishop's lawn. A piece, fine $\frac{3}{4}$ bishop's lawn.
- One dozen cotton fancy shirt fronts, all woven in the loom. A linen shirt front, woven in the loom.
- Three fancy linen handkerchiefs. Two dozen fancy printed cotton handkerchiefs. Six fancy printed linen handkerchiefs.
- A lady's printed cotton bonnet.
- 205 LEADBETTER, J., & Co., *Glasgow*—Manufacturers.
- Pieces of fancy linen, entire; mixed and union. Linen "listados." Fancy linen drills.
- 206 BAUMANN & WUNSCH, *Glasgow*—Agents for Manufacturers and Exporters.
- Printed shawls of wool, worsted, and cotton, of various styles, dimensions, and qualities; printed cotton shawls and handkerchiefs in same variety. Linens, in various stages of manufacture. Mixed fabrics.
- 207 HELME, W., *New Mills, Stroud*—Manufacturer.
- Cassimere waistcoats, of various colours and texture. Single-milled and half-milled doeskin. Cashmerette, silk warp, woollen wefts. Cassimeres. Sardinians for waistcoats.
- 208 GRIST, M., *Capels Mills, Stroud*—Manufacturer.
- Specimens of mattress-wools, woollen millpuffs, and flocks, used for filling beds and stuffing mattresses, sofa cushions, couches, &c. Manufactured by improved machinery, and purified during the process.
- 209 MARLING, S. S., & Co., *Ebley Mills, Stroud*—Manufacturers.
- Superfine broad cloth, single-milled, wool-dyed, woaded black, &c.; superfine doeskin, treble, double, single, and half-milled; superfine cassimere, single-milled.
- 210 HOOPER, C., & Co., *Eastington Mills, Stroud*—Manufacturers.
- Cloths, wool-dyed, woaded, piece-dyed, &c., viz., broad, black, blue, medley, scarlet, waterproof, fancy coloured, &c.
- Single-milled cassimere, black and scarlet.
- Patent elastic trousering, and gloving cloth.
- 211 PLAYNE, P. P. & C., *Nailsworth*—Manufacturers.
- Specimens of single-milled, woaded, wool-dyed, black cloth; superfine, woaded, wool-dyed, ladies' black cloth; and woaded, wool-dyed, black medium cloth. Case containing specimens, illustrative of the process of manufacturing woollen cloth.
- 212 PARTRIDGE, N., *Bowbridge, Stroud*—Designer.
- Double-colour woollen cloth, for officers' cloaks, dividing saloons in the East, curtains, &c. Army cloth, improved red.
- 213 PALLING, WILLIAM, *Lower Mills, Painswick*—Manufacturer.
- Piece of double-milled scarlet hunter, dyed, 54 inches wide.
- Piece of double-milled cloth, dyed, 54 inches wide.
- Piece of double-milled white, undyed, for trousers and waistcoats.
- Piece of fine single-milled scarlet, 63 inches wide.
- Piece of billiard cloth, 72 inches wide.
- Billiard cloth, green, piece dyed.
- 214 DAVIES, R. S., & SONS, *Stonehouse Mills, Stroud*—Manufacturers.
- Nash scarlet cloth, for officers' full uniform; shell cloth for undress jackets. White cloth for uniforms. Scarlet cloth, for foreign uniforms. Woaded wool-dyed black cloth; single-milled cassimere; double-milled and single-milled doeskin.
- 215 SAMPSON, THOMAS, *Lightpill Mills, Stroud*—Inventor.
- Machine for twisting the fringe of wool shawls.
- West of England wool shawls. Twilled black flannel. Scarlet flannel.
- 216 OVERBURY, JOSIAH, *Nind and Monk Mills, near Wotton-under-Edge, Gloucestershire*—Manufacturer.
- Superfine Saxony woollen cloths, wool-dyed, woaded, black, rifle, and medley, and blue-indigo, dyed.
- 217 PHILLIPS, SMITH, & PHILLIPS, *Melksham*—Manufacturers.
- Sample pieces of fine Saxony broad cloth, consisting of woaded olive (of different shades), woaded rifle, and wool-dyed black.
- 218 EDMONDS & EDMONDS, *Bradford, Wilts*—Manufacturers.
- Piece of superfine woollen wool-dyed black cloth, made on a patent principle.
- Piece of superfine blue cloth, made on the same principle.
- Piece of superfine woollen cloth, waterproofed.
- 219 BARNES, ELIZABETH, 35 *Queen Street, Oxford*—Designer and Manufacturer.
- Counterpane, composed of 9,851 pieces, of hexagon shape, and about the size of a shilling, with a border of amber-coloured satin, quilted, of same size and shape, and a quilted lining; the whole the work of an invalid.
- 220 PETERS, DANIEL, 44 *College Green, Bristol*—Manufacturer.
- Black single-milled kerseymere.
- 221 CHICK, ROBERT, *Knapp Mills, near Chard, Somerset*—Manufacturer.
- Samples of drab cloth, made of English wool by power-loom.
- 222 PHILLIPS, JOHN, *Knapp Mills, near Chard, Somerset*—Manufacturer.
- Striped linsey wolsey, blue and white, made from flax and wool. Plain blue linsey, and white linsey, made from flax and wool.
- These articles were formerly much used by the middle and lower classes for aprons and petticoats; they are again coming into general use, especially for the inmates of Union houses, and charitable institutions. They are durable and close in texture.

223 BIRD, R., *Crewkerne*—Manufacturer.
Linen, worsted, white and coloured linen and worsted, webs for girths, braces, &c.

224 STANTON & SON, *Land's Mill, Fordington, near Dorchester*—Manufacturers.
Drab milled waterproofed cloths, made from English wool; used for driving capes, coachmen's great-coats, box-coats, livery coats, gaiters, &c.

225 ALLEN, GEORGE, *St. Stephens Street, Norwich*—Manufacturer.
Elastic cloths for trousers, gloves, &c.

226 ALLEN & BANKS, 21 *London Street, Norwich*—Proprietors.
East Anglian woollen cloths for gentlemen's wearing apparel, manufactured from wool grown in the county of Norfolk.

227 GARVIE & DEAS, *Perth*—Manufacturers.
Linsey-woolsey, for ladies' dresses. Hand-knitted hose. Hand-loom grass-bleached cotton shirting, &c. Cotton and linen bed-tick.

228 CROMBIE, JAMES, & Co., *Cothal Mills, Aberdeen*—Manufacturers.
Scotch tweeds, of various qualities.

229 THOMSON, W., *Stonehaven, Scotland*—Manufacturer.
Piece of cloth, being a specimen of a method of working up engine waste, into floor-cloth or carpeting.

The specimen claims notice only as exhibiting an easy and inexpensive method of working up the coarsest engine waste into an article of general utility. The warp is linen or tow yarn twisted, nine pounds per spindle. The weft is made of the least valuable portion of the waste that falls from the wool-carding engines; slubbed or spun thirty-six to forty pounds per spindle. The warp is set very thin, nine threads to the inch, woven plain. The pattern is produced by doubling and dipping one end of the hank of weft into the dye vat, and in weaving it falls into the pattern exhibited. The cloth is durable, from the warp threads being covered and protected on both sides by the weft.

230 BRUNTON, WM. J., & Co., *St. Leonard's Factory, Edinburgh*—Designers and Manufacturers.
A variety of fine wool scarf shawls, variously named. Superior gentlemen's plaids—the Durobin. Specimen of German lambs' wool and yarn, of which the shawls are made.

231 BOWMAN, JAMES, & SON, *Langholm*—Manufacturers.
Shepherd check tweeds, of Scotch and Australian wool.

Fancy shepherd tweed, and fine shepherd check of Australian wool.
Shepherd check union, and shepherd union of cotton and wool.

Gentlemen's shepherd plaid of German wool.

232 BYERS, ANDREW, & SON, *Langholm*—Manufacturers.

Specimen of union shepherd's tweed, cotton twist warp and Cheviot wool weft, for trousers, and of 6-6 shepherd's tweed, made of strong Cheviot wool. Granite tweed, elastic, of foreign wool, double twist. Shepherd's tweed, elastic, double twist, of foreign wool. 39-inch linsey, made of cotton twist and woollen weft. 6-6 shepherd's scarf, for plaid, made from fine foreign wool, double yarn. Railway plaid, or wrapper, made from double twist yarn, foreign wool. 4-4 shepherd's tweed, elastic, double twist, from foreign wool.

233 RENWICK, THOMAS & ALEXANDER, *Langholm*—Manufacturers.

Specimens of linsey-woolsey weft, Eskdale shepherd plaid, and Scotch hosiery yarn; Scotch tweed and marble yarn of Australian wool.

234 DICKSONS & LAINGS, *Hawick and Glasgow*—Manufacturers.

Scotch lambs'-wool hosiery, &c., of various descriptions, patterns, and qualities, including men's hose and half-hose, Highland clan tartans, women's hose, men's shirts, gauze shirts, long drawers, ladies' vests and dresses, &c.

Clan tartan; shepherdess tartan, and fancy tartan wool plaids. Cheviot, Australian, and Saxony wool trouserings.

235 SMITH, J. & SONS, *Saddleworth, near Manchester*. Agents, NIELD and COLLANDER, London.

Fine and superfine and silk warp and stout flannels; fine and superfine and silk warp.
Shawls and scarfs for printing.

236 HAIGH, THOMAS, & SONS, 9 *New Brown Street, Manchester*—Manufacturers.

Black broad cloth. The same, wool and cotton.

237 BAMFORD, JOHN, *Rochdale, Lancashire*—Manufacturer.

Fine gauze flannel, manufactured from sheep's wool.

238 LEWIS, WILLIAM, *Llandilofarn, Wales*—Manufacturer.

Welsh woollen cloth.

239 PEARSON, J., *Carlisle*—Manufacturer.

Woollen and cotton trouserings.

240 DALRYMPLE, WILLIAM, *Union Mills, Douglas, Isle of Man*—Manufacturer.

Shepherd plaid, cloth made from Australian wool. Striped and Tweed cloth and shepherd plaid, made from the wool of the island, and manufactured by the natives.

241 WHITMORE & Co., *Leicester*—Manufacturers.

Worsted yarns for hosiery, fleecy, and for embroidery and soft knitting.

242 BREWIN & WHETSTONE, *Leicester*—Manufacturers.

Worsted and merino yarns.

243 BURGESS, ALFRED, & Co., *Leicester*—Spinners.

Berlin wool embroidery yarns, spun by the exhibitors, from German and colonial wools.

Soft and hard knitting yarns.

Shetland, embroidery, weft, hosiery, alpaca, mohair, and other yarns, single and doubled.

Specimens of the different wools used in the manufacture of these yarns, and in the various stages of preparation, until finished into yarns.

244 POPPLETON, R., *Westgate, Wakefield*—Manufacturer.

Manufactured knitting worsteds and yarns.

245 WILSON, JOHN J. & W., *Kendal*—Manufacturers.

Railway wrappers plain, and with varied design and colour on both sides. Stout horse-clothing; also, fine and light clothing, for race-horses.

246 GANDY, GERARD, *Kendal*—Manufacturer.

Brace, girth, and roller webs, in worsted and woollen and manufactured entirely with worsted.

Horse sheetings, railway blankets, blue and white seyes, broad and narrow collars-checks, with other woollen articles for the use of saddlers.

247 IRELAND, JOHN, & Co., *Kendal*—Manufacturers.

Railway travelling rugs of various qualities, and hospital bed-rugs. Horse blankets of various qualities. Alpaca cloth for ponchos, coatings, &c. Saddlecloths, for foreign markets. Prince's check and kersey, for horse clothing. Serge and collar check, for saddlery purposes. Saxony lining. Tilting, for horse clothing, &c.

Checked flannel, for shirting.

- Plaiding, for sailors' shirts.
Lisburn check, for horse clothing.
Linsey and druggat, for women's clothing.
Gentlemen's scarfs (shepherds' plaid pattern).
- 248 MANSSELL, DAVID, *Brecon*—Manufacturer.
A variety of woollen goods.
- 249 MARTIN, J., *Cockermouth*—Inventor.
Ventilating waterproof cloth and paper.
Improved mode of making all kinds of cloth and paper, including silk, net, lace, &c., complete repellants of moisture.
The paper is manufactured by I. Cropper, Esq., Burneside, near Kendal.
- 250 SALTER, SAMUEL, & Co., *Trowbridge, Wilts*—Manufacturers.
Specimens of fine woollen trouserings, comprising fancy plaids, ribbed checks, doeskin, black cross rib, black elastic, black deerskin, black fancy elastic, military mixture, and elastic Angola.
- 251 HUGHES, ROBERT, *Tregarth, Bangor, Wales*—Manufacturer.
Gown pieces of Welsh linsey, and apron of the same, woven in a loom, invented and constructed by the exhibitor.
- 252 WILSON, W., & Sons, *Hawick*—Manufacturers.
Scotch mauds, and travelling wrappers.
- 253 MILLS, ELIZABETH, *Dolgelly*—Inventor and Manufacturer.
Linsey dresses, mixed with silk. Linsey aprons.
Waistcoat-pieces, made of Welsh wool.
Welsh cloth, for gentlemen's shooting-clothes. Cricket cloth. Merionethshire web.
- 254 LLOYD, WM., & Co., *Newtown, Montgomery, Wales*—Manufacturers.
Various specimens of Welsh flannel, all manufactured from sheep's wool.
- 255 PIM BROTHERS & Co., *Dublin*—Designers and Manufacturers.
Specimens of plain Irish poplin, double tabinet, corded, tartan, and figured poplins, registered designs; brocadéd poplin.
- 256 ATKINSON, RICHARD, & Co., *31 College Green, Dublin*—Proprietors.
Brocadéd and gold-barred Irish poplin, with rose, thistle, and shamrock coloured to nature.
Gold tissue Irish poplins, pattern, Prince of Wales's plume. Irish poplins, brocadéd, ribbed, and double; double watered, demi-ribbed, and plain; and shaded, plaided, and figured.
Brocadéd and tissue Irish poplin scarfs; Irish poplin waistcoatings tissue with gold; and brocadéd and figured.
Striped furniture and figured tabourets. Specimens of all kinds and qualities of Irish poplins.
- 257 WILLANS BROTHERS & Co., *Island Bridge Mills, near Dublin*—Manufacturers.
Albert and brown mixture, super frieze.
Cambridge mixture, tweeds for shepherd's plaids.
Officers', serjeants', and privates' military tartan.
Woollen shawl yarn.
- 258 DILLON, J-JUKE, *7 Parliament Street, Dublin*—Designer.
Pieces of friezes and "rumswizzles," of different colours and substances; comprising light angola, medium and heavy materials for clothing purposes.
The rumswizzle is made from undyed foreign wool, preserving its natural property of resisting wet, and possessing the qualities of common cloth.

- 259 ALLEN, RICHARD, *28 Lower Sackville Street, Dublin*—Proprietor.
Irish-made heather tweeds, of various shades.
Irish frieze, natural colour, undyed.
Superfine and napped frieze.
Sheep's grey frieze, county Meath colour.
Dark grey frieze, Connaught colour.
Black cassimere embroidered vests.
This portion of Irish manufacture, is, probably, one of the most interesting in Ireland. The designs are by James Healy, a pupil of the Dublin School of Design. They are worked by Miss Hamilton and others.
Irish lawn embroidered vest pieces. Linens, various qualities.
Irish linen shirt fronts and Irish linen shirts; exhibited for quality and work. Frieze wrapper, for gentlemen, lined with Irish tabinet.
Irish sheep's grey and undyed wool frieze pea coats. Four-in-hand frieze wrapper. Black tweed morning coat. Heather-tweed shooting coat. Tweed youth's morning coat. Frieze youth's polka jacket. Frieze Connaught man's coat.
The preceding are exhibited for manufacture, workmanship, and costume.
Fancy tabinet vests.
Frieze embroidered vests of black cloth. Lawn embroidered vests. Linen coats.
Samples of figured and double-watered tabinets, manufactured by Edward Jones, of 3 St. Andrew Street, Dublin.
- 260 MACDONA, G., *32 Molesworth Street, Dublin*—Manufacturer.
Piece of frieze, designated the "Albert frieze."
Pieces of heather and black tweeds.
Patent drawers, with bands attached.
Black embroidered tabinet vesting, embroidered gold.
Black embroidered cloth vesting, embroidered gold.
- 261 NICOLLS, ALEXANDER, *Cork, Ireland*—Manufacturer.
Blankets, flannels, swanskins, and friezes.
- 262 MURPHY, MARGARET, *Ballysmutton, Blesinton, Ireland*—Manufacturer.
Home-made frieze, from wool grown and spun by the exhibitor.
- 263 NEILL, CATHERINE, & Sons, *Tallaght, Dublin*—Manufacturers.
Brown mixed, and sheep's grey frieze.
Blankets.
- 264 DALY, JOHN, *Tipperary, Cashel, Ireland*—Manufacturer.
Specimens of plain friezes, of various colours, chiefly used for men's clothing, and horse-sheeting. Manufactured at Rossmore mills.
- 265 JONES, E., *Dublin*—Manufacturer.
Specimens of tabinets and poplins.
- 266 REYNOLDS, WILLIAM, *81 Grafton Street, Dublin*—Designer and Manufacturer.
Imperial blue and gold, and white and gold tissue poplin.
White and gold, marone, light blue and silver corded, white and gold shamrock figured poplin.
Imperial blue and amber ("oncidium Devonianum"), crimson and fawn colour furniture poplin.
Imperial blue and white striped, pink and white, sage and violet, cerulean blue and white, cerulean blue and cerise, peach-blossom, jonquil, lavender, amaranthe, rose de Chine, white, apricot, and Imperial blue double-watered furniture poplin.
Scarlet, "juif errant" green, and emerald unwatered furniture poplin.
Rose de Chine and white corded furniture poplin.
Jonquil, apricot, and cerulean blue semidouble corded poplin.

Silver grey, white, blue, and cerise, tri-couleur shamrock-figured poplin.

Imperial blue, fawn and scarlet, fawn and violet satin plaided poplin.

Green and white, solitaire and white, and pearl and cerise plaided poplin.

Royal Victoria, Royal Albert, Royal Stuart, and Gordon tartan poplin.

Imperial blue and white checked poplin.

Grey shaded and stone-colour semidouble poplin.

Cerulean blue, couleur de rose, and vers d'Illy plain poplin.

Crimson and amber furniture poplin (Shrewsbury arms).

267 FRY, WILLIAM, & Co., *Dublin*—Manufacturers.

Mixed fabrics; plain and shaded, figured, watered, plaid tartan, and brocaded poplins.

Curtains, figured, striped, and velvet tabarets.

Miscellaneous manufactures and small wares. Patterns of coach laces.

268 EARLY, J., & Co., *Witney*—Manufacturers.

A variety of Witney blankets.

269 EARLY, EDWARD, *Witney*—Manufacturer.

Witney blankets, made from different descriptions of English wools.

Blankets made from merinos; from half-bred merinos; from pure South-downs; from half-bred Downs; from Oxfordshire long wool; from Cotswold wool; and from a mixture of the previous lots, and some Welsh lambs' wool.

Various crib blankets, girth and roller webs, &c.

270 BLISS, WILLIAM, *Chipping Norton, Oxfordshire*—Manufacturer.

Kersey check for winter horse-clothing; in new and fancy patterns, with a specimen suit of horse-clothing, ornamentally bordered.

Registered double kersey check for improved ventilating horse-clothing, combining the advantages of a suit of horse-clothing and a blanket; various patterns, with specimen suits made up in a new method.

Superfine kersey check for clothing race-horses; various patterns, with a specimen suit, and a suit of blanket clothing for training race-horses.

Prince's check for summer horse-clothing, in new patterns, with a suit of clothing.

Roller webbing for horse-clothing. Girth, belt, and brace webbing. Railway aprons.

Alpa Vicuna beaver cloth, fine, for ladies' cloaks; and stout, for gentlemen's great-coats.

Tweeds for gentlemen's trousers.

The registered Alpa Vicuna Royal shawl; specimens in new patterns and colours.

Angola Royal shawls, in various patterns and colours. Beaver shawls.

Registered winter coverlets for beds.

Cot coverlet, woven in imitation of the Indian tambour and basket-work, and ornamented with needle-work.

Imperial "puss" bagging, shown in various substances and widths.

White "puss" cloth. Venetian cord, in a variety of colours.

271 WHEELER, WILLIAM SIDNEY, *4 Ludgate Street*,—Manufacturer.

Samples of patent fur beavers; patent dress beavers; patent mohair cloths; fancy doeskins, and woollen and silk vestings.

The novelty of the above patent mohair cloth and patent beavers is in their being manufactured on a principle entirely different from that of other cloths, and from the peculiarity of the construction in the weaving, possessing great advantages in warmth and wear.

272 FOX, JOHN J., & Co., *Devizes*—Manufacturers.

Drab milled broad-cloth, waterproof, made of South-down wool, grown in Wiltshire.

Narrow cloth for trousers, made of the same wool, with samples of the raw material, in various stages of manufacture.

273 CARR, T. & W., *Twerton Mills, Bath*—Manufacturers.

Super-electoral blue cloth (indigo-dyed), and fast black cloth, from German wool. Bath fur beaver, and dressed fur—fine Australian wool. Extra-milled black beaver, and black Venetian, or summer cloth—German wool.

274 JOHNSTON, J., *Newmill, Elgin, Scotland*—Manufacturer.

Mauds, or plaids, made of undyed or natural brown wool, of different kinds and countries, viz., Cheviot, Southdown, Australian, Peruvian, Alpaca, Vicuna, &c. They are used as a wrapper for the shoulders in walking, or for the knees in driving.

Ends, twenty yards each, natural brown tweed, of different wools, waterproofed. These cloths are exhibited for cheapness and durability.

Nos. 275 to 313 in South Transept Gallery.

Shawls in the South-west Gallery of the Transept.

275 KERR & SCOTT, *31 and 32 St. Paul's Churchyard*—Warehousemen.

Various long and square grenadines, all silk; and Barège, silk and wool. Square satin figured; and scarf, embroidered with gold and silk. Square chenilles. Long and square Barège harness, wove and printed; long grenadines; square Albanian; long soft silk; and Barège, with silk stripes. Square crapes, printed in imitation of real China. Long and square wool shawls, clan and fancy patterns; combination of colouring. Cloakings, clan patterns. Harness and jacquard-wove shawls. Long and square mosaic compartment, green, white, and scarlet cashmere. Long floral cashmeres, and soft silks. Squares soft silk, single and double wove. Long India coloured and square compartment cashmeres. Manufactured by R. Kerr, Paisley.

276 LEWIS & ALLENBY, *193, 195, & 197 Regent Street*—Proprietors.

Barège shawls of British printing (registered). The design, by C. J. Lewis, so arranged as to admit of various combinations of the blocks without destroying in any part the continuity and completeness of the pattern, with either plain or filled centre.

277 WEBBER, JOHN, & HAIRS, GEORGE, *31 Milk St. City*—Producers.

Printed Barège long and square shawls; Cashmere and Grenadine. Printed handkerchiefs, various; and Foulard dresses.

278 JAMESON & BANKS, *Honey Lane Market, Cheapside*—Manufacturers.

Barège long shawls, printed, wool texture; silk and mixed texture.

Barège square shawls, of the same description.

Cachemire d'Ecosse, printed, wool texture.

Crape square shawls, printed, silk texture.

279 KEITH, SHOOBRIDGE, & Co., *124 Wood Street*—Producers and Proprietors.

Shawls: printed Barège long and square; grenadine silk; Cachemere; mufflers; and satin long and square.

280 HOLMES & Co., *117 Regent Street*—Designers and Manufacturers.

Circular shawl, new in form and design. Registered by the exhibitors.

281 STANDEN & Co., *112 Jermyn Street, St. James's*—Importers.

White Shetland knitted shawl. Bridal veil. Pair of white stockings. Brown, grey, and white gloves—natural colours. The Shetland wool of which these specimens consist is hand-spun.

- 282 LITTLER, MARY ANN, *Merton Abbey, Surrey*—
Producer.
Barège shawls, of British manufacture.
Twilled bandannas, of British manufacture.
Specimens of wax and chintz printing; exhibited for
novelty of design and colour, madder red.
- 283 SWAISLAND, CHARLES, *Crayford, Kent*—Manufacturer.
Printed Barège shawls.
Printed Chinese velvet for furnitures (or application
push).
Printed flannels for dresses.
- 284 CLABBURN & SON, *Norwich*—Manufacturers.
Registered figured Cashmere shawls.
Spun-silk, fancy check, and Albanian silk shawls.
Registered Jacquard figured poplins, and Chiné poplins.
Jacquard figured and plain dresses, mixed fabrics.
- 285 BLAKELY, EDWARD THEOBALD, *River House Factory,
Duke's Palace, Norwich*—Manufacturer.
Norwich Cashmere green scarf shawl, gold introduced.
Shawls of Cashmere wool, pine and flower pattern; and
pine and flower pattern, gold introduced: the effect pro-
duced is by eighty-eight shoots on the inch: design by
John Funnell.
Anglo-Indian scarfs, shawls, dresses, brocade, &c.
- 286 TOWLER, CAMPIN, & Co., *Elm Hill, Norwich, and 46
Friday Street, London*—Manufacturers.
Fillover scarfs: silk ground, the pattern extending
four yards in length and two in width. Silk ground
of new designs, and mixed material; the same, white silk
scarf and shawl, printed.
White silk-net shawl, printed. Black silk-net shawl,
printed.
Ladies' paletots, woven to fit the shape, on silk ground,
and of mixed materials, with and without ornamented
villover work.
Black silk net scarf, printed.
- 287 WHITEHILL, M., & Co., *Paisley*—Manufacturers.
Worsted and cotton scarfs, with tamboured ends; and
shawls and handkerchiefs, embroidered; the same in
wool.
Quilting, cloth, and wool embroidered vests.
Embroidered satin aprons and babies' robes.
Tamboured and embroidered dresses. Zephyr shawls.
Silk dresses.
Plain black scarf and shawl. Cashmere and Barège
scarfs and shawls. Velvet vests. Table-covers. Cloakings.
- 288 HOLMS BROTHERS, *7 St. Mirren's Street, Paisley, and
21 Friday St., Cheapside*—Manufacturers.
Fine wool long shawls—the tartans of the clans of
Scotland. Fancy tartan and plain wool long shawls.
Vicuna long shawl. Wool tartan cloaking.
- 289 BURGESS, CHARLES, *Paisley*—Manufacturer.
Long woven shawls.
- 290 BAIRD, JOHN, *Paisley*—Manufacturer.
Embroidered French merino ladies' dresses. Embro-
idered Canton crape shawls.
- 291 FORBES & HUTCHISON, *Paisley*—Manufacturers.
Paisley woven, printed, tartan wool, embroidered, and
figure gauze shawls. Printed, tartan wool, and em-
broidered handkerchiefs. Printed and tartan wool muf-
fers. Embroidered vests, and robe. Tartan and printed
dresses.
- 292 ABERCROMBIE & YULL, *Paisley*—Manufacturers.
Printed long and square shawls.
- 293 CLARK, JOHN, jun., and Co., *Causeyside, Paisley*—
Manufacturers.
Printed Cashmere long and square shawls or plaids.
- 294 LAWSON, JOHN, & Co., *Caledonia Print Works, Paisley*
—Printers.
Barège printed shawls in wool, and in silk.
- 295 DICK, WALTER, & SONS, *Paisley*—
Printed Cashmere shawls.
- 296 ROXBURGH, JOHN & ANDREW, *Paisley*—
Manufacturers.
Woven long shawls.
- 297 MACFARLANE, SON, & Co., *Paisley*—Manufacturers.
Spun silk fabrics, for ladies' dresses, in clan tartans and
fancy designs.
- 298 STEWART, ROBERT, *Paisley*—Proprietor & Producer.
HUTCHISON, THOMAS, *Paisley*—Inventor and Patentee.
Machine for inventing and displaying patterns in stripes,
cheques, and tartans, by means of sliding mirrors and
coloured glass, suitable for manufacturers of textile
fabrics, whether in cotton, woollen, silk, or linen, or a
combination of two or more of these materials.
The advantages of this machine are—the facility with
which any pattern, or idea of a pattern, may be set up
and displayed—the variety of designs it can produce—
and the ease and simplicity of accomplishing them. It is
not at all necessary to paint the pattern on paper, after
viewing it through the mirrors, as the scales attached
show at once the required number of threads of each
colour, and how many repeats are necessary for the
breadth of the web, and it displays at once, not only the
repeat, but the whole breadth, and a considerable portion
of the length of the cloth at one view.
By this invention, the precise effect of a pattern may be
produced, in the course of a few minutes, without any
expense, multiplied to any extent, and it may be enlarged
or diminished at pleasure. The chief novelty, however,
of this machine, which is exhibited for its simplicity and
the ease of its adaptation, is, that the precise effect of the
cloth in a finished state is accurately represented, the
crisp transparent effect of a silk fabric being truly given,
as well as the soft and more opaque effect of a woollen
fabric.
This invention is new in principle, being a novel appli-
cation of coloured glass to useful and essentially practical
purposes.
- 299 MORGAN, JOHN, & Co., *Paisley, and St. Paul's Church-
yard, London*—Manufacturers.
Woven long shawls, of Cashmere yarn and new designs;
of silk and wool; and of mosaic style. Woollen plaids.
Printed Barège long shawls.
- 300 KERR, ROBERT, *Paisley*—Manufacturer.
India long and square shawls. Printed and fancy wool
long and square shawls.
- 301 ROBERTSON, J. & J., *3 Forbes Place, Paisley*—
Manufacturers.
Coloured woven harness, wool plaids and shawls;
coloured printed plaids and shawls, in Barège, Cashmeres
d'Ecosse, and Cashemere fabrics.
- 302 ROWAT, R. T. & J., *Paisley*—Manufacturers.
Printed Barège and Cashmere long shawls; printed
wool square shawls.
- 303 MASON, W., & Co., *Honey Lane, Cheapside*—Producers.
Dress fabrics—printed Cashmere and Llama wool tex-
ture.
Printed chiné, glace, and printed and embroidered
"jaspé" cashmere, wool and cotton texture.
- 304 WELCH, MARGETSON & Co., *Cheapside*—
Manufacturers.
Dressing-gown fabrics.

305 SALOMONS, B., & SONS, 42 *Old Change*—Proprietors.

Child's frock, embroidered on French cambric.
A lady's embroidered robe.
Ladies' worked sleeves; worked muslin chemisettes, habit shirts, collars, jaconet collars, and trimmings.
Samples of Irish cambric handkerchiefs, embroidered in Ireland; and of French cambric handkerchiefs.
Specimens of muslin trimmings, flouncings, and insertions. Ladies' embroidered muslin dresses, &c.
Samples of ladies' stays, &c.
Selection of muslin and lace articles, and of articles for mourning, for ladies' wear.
Selection of patterns of new trimmings, for dresses and mantles.
Mixed fabrics of silk and wool, fancy materials, for ladies' dresses.
Embroidered dress and mantle, &c.

306 PUGH, J. W., 163 and 165 *Regent Street*—Producers.
Mixed fabrics.307 SAYCE, J., & Co., *Cornhill*—Manufacturers.

Mixed fabrics. Patent piuma, or six-ounce coat, with only one seam in the body, of a material known hitherto chiefly in India, and "manufactured by the poor Hindoos." Gutta percha cases. Plain piuma cloth, waterproofed. A new material, a mixture of silk and vicugna, extra waterproofed.

308 GODEFROY, P. A., 3 *King's Mead Cottage, New North Road, Islington*—Inventor and Manufacturer.

Specimens of woven fabrics in various colours, plain and figured, finished by patent machinery. In dressing and finishing the colours of the fabrics are firmly fixed, and rendered brilliant by chemical agency.

309 TOWLER, CAMPIN, & Co., *Elm Hill, Norwich, and 46 Friday Street, London*—Manufacturers.

Norwich challi.
Satin striped de laine for ladies' dresses.
Paramatta cloth for ladies' dresses. Figured and plain barège for dresses.

310 WILLET, EDWARD, NEPHEW, & Co., *Norwich*—Manufacturers.

Samples of mixed fabrics for ladies' dresses, consisting of black and coloured bombazines and paramattas; plain and figured poplins, in two colours; santillano, china brocade, and estella brocade, figured in two colours; satin striped chiné, three colours; plain and figured bellano, in two colours, &c.

Two patterns of a mixed fabric, composed of materials the produce of nine different countries.

311 BOLINBROKE, C. & F., *Norwich*—Manufacturers.

Plain and watered poplins.

312 MIDDLETON & AINSWORTH, *Norwich and London*—Manufacturers.

Poplins corded and brocaded, and black paramattas.

313 HINDE, E. & F., *Norwich*—Manufacturers.

Barèges and brocaded poplins.

432 CLARKE, THOMAS, *Stephen Street, Waterford, Ireland*—Manufacturer.

A camlet cloak, which has been in constant use for more than twenty years.

A piece of the same ravelled, to show the texture.
A sample of the like fabric and composition, but of a different colour, warp blue, weft green.
Sample of stuff, single threads, half cotton half worsted, undyed.

Samples of white serge, single yarn; grey serge, double yarn; green serge, single yarn; and blue serge, double yarn.

Sample of stair carpet, green, taken off a piece which has been in use for 16 years; all wool, both warp and weft, and woven by a linen weaver.

A sample of green flannel, as used by the peasantry and working people of the counties of Waterford and Wexford, Ireland.

459 SMITH & WHYTE, *Glasgow*—Manufacturers.

Embroidered robe de chambre and lady's dress.

460 ROBERTS, R., *Llanberris Road, Carnarvon, Wales*—Manufacturer.

Linsey-woolsey manufactures.

461 ARCHIBALD, JANE R., *Tillicoultry*—Manufacturer.

Plaid shawls.

462, 463, 467, and 468 placed on the North Wall with Class VI.

462 BRUNTON & NESBIT, *Edinburgh*—Producers.

Shawls and scarfs.

463 BRAYSHAM, GEORGE, 61A *Park Street, Camden Town*—Maker.

Pictorial mosaic cloth-work table-cover or quilt, comprising 32 compartments exclusive of the centre, which is the arms of England; each compartment being an imitation of some well-known picture, made of coloured cloths, fine-drawn together so as to imitate paintings, the features being worked with the needle, the whole surrounded with a border. This work has been the labour of leisure hours for a period of nine years and a half.

464 GIBSON, WILLIAM, & Co., *Tillicoultry, Alloa, Scotland*—Manufacturers.

M'Kenzie and M'Lean clan tartan woollen shawls. Fancy woollen shawls. Frazer and Forbes clan tartan, for ladies' dresses and cloaks.

465 ARCHIBALD, ROBERT, & SONS, *Tillicoultry, Alloa, Scotland*—Manufacturers.

Rob Roy, Colquhoun, and M'Donald of Staffa tartan long shawls. Malcolm and Bruce tartan wool shawls. Fancy wool shawls. Royal Stewart and Gordon tartans for cloaks or dresses. Fancy tartans. All of woollen fabric.

466 PATON, J. & D., *Tillicoultry, Alloa, Scotland*—Manufacturers.

Long wool shawls, of various Highland clans and fancy patterns.

Fancy wool tartan, designed by Messrs. Romanes and Paterson, Edinburgh.

Long wool fancy shawls, designed by Messrs. Mitchell, Miller, and Ogilvie, Glasgow.

Long wool fancy shawls, designed by Messrs. Arthur and Frazer, Glasgow.

467 SINCLAIR, JOHN, jun., 49 *South Bridge Street, Edinburgh*—Manufacturer.

Scarf plaids, Royal Stuart; Victoria; Sinclair; Sutherland or 42nd; all wool. Pieces of Tartan, Royal Victoria; McDonald of Slate, or Duke of Rothesay; Sutherland or 42nd; all wool.

Tartans were worn in the Western Islands and Highlands of Scotland as early as 1090, and are supposed to have been introduced by Queen Margaret. Each clan has a separate pattern, or tartan, for itself, bearing its name, and worn by all the individuals of the clan.

468 WILSON, W., & SON, *Bannockburn, near Stirling, Scotland*—Manufacturers.

Woollen manufactures.

469 BROWN, JAMES & HENRY, & Co., *Ettrick Mills, Selkirk, Scotland*—Manufacturers.

Scotch tweeds and fancy woollens, of various new mixtures and styles.

470 HALLY, GEORGE, *Perthshire*—Manufacturer.
 Plaids in several varieties.

472 HUGHES, W., *Benygroes, near Carnarvon*—
 Weaver and Producer.
 Worsted and silk dresses.
 Aprons, of Welsh linsey. Table-cover, of wool and
 flax, a specimen of Welsh weaving.

474 SCHOFIELD, ABEL, *Spring House, near Delph,
 Saddleworth*—Manufacturer.
 Patterns of woollen goods manufactured in the years
 from 1780 to 1820, showing the styles of that period.
 Fine doeskin, or satin-face, all wool, suitable for vest-
 ings, ladies' or babies' clothing, &c.
 Fine buff prunell cashmere, a little milled.
 Fine white cashmere, containing 144 picks in the inch,
 for shawls, ladies' dresses, &c.
 Crimson merino.
 Maude fabrics for shawls, and specimens of colours
 dyed in shades.
 Fine patent black broad cloth and cassimeres.

475 HUGHES, WILLIAM, *Bethesda, near Bangor, Wales*—
 Manufacturer.
 Durable bed-covering.

477 WATSON, J. & A., *Galashiels, Scotland*—
 Manufacturers.
 Scotch clan and fancy plaids. Ladies' woollen scarfs
 or shawls. Woollen tartans (ladies' dresses). Scotch
 tweeds.

480 ROBERTS, W. & Co., *Galashiels, Scotland*—
 Manufacturers.
 Pieces of Scotch tweeds.

481 REID, D., & SON, *Langholm*—Manufacturers.
 Cotton and Scotch wool hose; shepherd's plaid check
 made from Cheviot wool; Australian and German wool;
 fancy check made from wool (elastic); blue grey check,
 made from Australian wool; fancy union tweed, made
 from cotton and Cheviot wool.

486 KELSALL & BARTLEMORE, *Rochdale, Lancashire*—
 Manufacturers.
 Flannel: ordinary quality, English wool; middle quality,
 New Zealand wool; fine quality, Australian wool.
 Electoral and Saxony flannel, and electoral shawl,
 German wool. Gauze and imitation "Welsh" German
 wool.

487 BROOK, JOHN & SON, *Upper Thong, near Huddersfield*
 —Manufacturers.
 Specimens of woaded black broad cloth, cassimere, and
 doeskin.

490 BURNLEY & SONS, *Heckmondwicke, near Leeds*—
 Manufacturers.
 English, Witney, and Irish blankets. American Mac-
 kinnow and scarlet striped blankets. American blankets,
 for clothing purposes.

493 THOMAS, W., *Haworth, Keighley, Bradford*—
 Manufacturer.
 Dyed wool, combed; wool-dyed yarns, in hanks and on
 spools; dyed yarn, floated with silk.

496 STOWELLS & SUGDEN, *Bradford*—
 Manufacturers.
 Crimson and white two-fold mohair yarn.

500 HIS ROYAL HIGHNESS PRINCE ALBERT.
 (*Main Avenue, West.*)
 Two brocaded dresses, manufactured by T. Gregory
 and Brothers, Shelf, near Halifax, Yorkshire. The weft
 of the Cashmere wool shorn from the goats kept by
 H.R.H. Prince Albert, in Windsor Park. The warp is of
 silk.
 Two shawls and a specimen of coarse cloth manufac-
 tured by J. Haley and Son, Bramley, near Leeds. The
 whole of the material is of the Cashmere wool as above
 described.

The Cashmere goat's wool, of which these articles are
 manufactured, consists of two distinct materials called
 wool and kemp. The wool is beautifully rich and soft to
 the touch, and is probably superior in this respect to the
 finest continental lamb's wool, and equal to the richness
 of the Thibet wool. It is also divisible into qualities.
 The kemp presents the appearance of a course rough hair,
 such as is avoided by the manufacturer in all purchases
 of wools, deteriorating as it does the appearance of even
 common fabrics by its inferiority and harshness.

The two wools, as shorn from the goat, are closely in-
 termingled, and present the appearance of coarse hairy
 wool of a very low character; but a minute inspection
 shows that part of it is of a very fine quality. In order
 to separate this fine quality from the coarse, it is ne-
 cessary to do so fibre by fibre; and this has to be effected
 entirely by hand, no machinery having as yet been applied
 to this purpose. The process is both difficult and tedious;
 one person not being able to separate more than half an
 ounce in twelve hours.

After the separation of the qualities, it is desirable
 further to divide it, in order to make a warp yarn for
 fabrics like the shawls; but this was impossible in the
 present instance, owing to the small quantity produced,
 otherwise the fabric would have been much finer. In the
 dresses this result has been achieved, because the warp is
 of silk, and the quantity required for the weft was there-
 fore not so great in proportion.

The specimen of coarse cloth is manufactured entirely
 of the coarse hairs or kemp after it is assorted from the
 finer material of the wool. In a general way this is con-
 sidered worthless.

501 UNDERWOOD, W., *1 Vere Street, Oxford Street.*
 Heraldic tapestry hanging. The Royal Arms can be
 substituted by the arms of any other family. Cloth cur-
 tains in various colours. (*In South Transept Gallery.*)

Nos. 463, 467, and 460—*Ground Floor, North Side, behind
 Western Refreshment Room.*



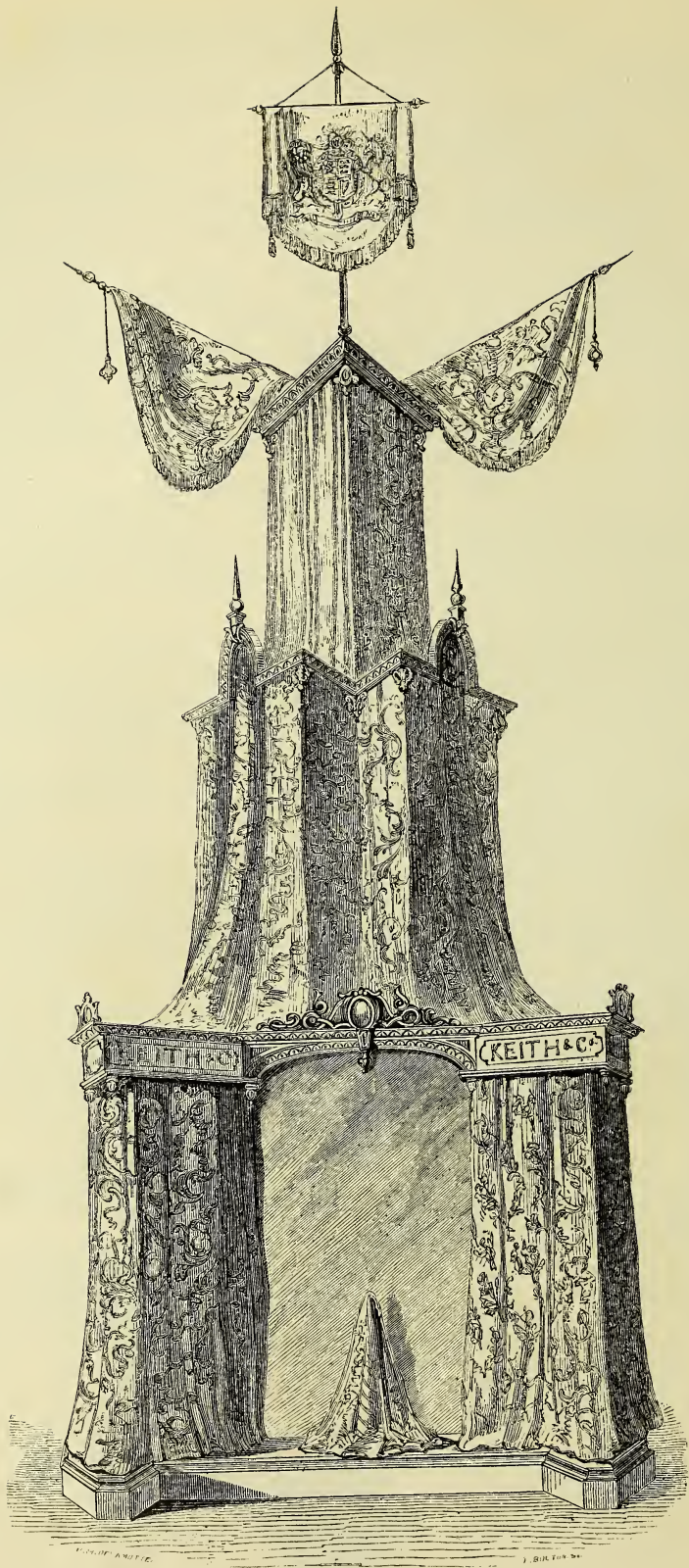

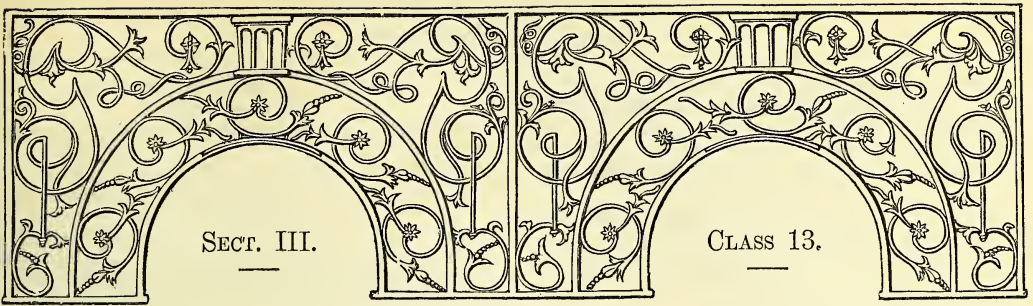

SILK AND VELVET.

INTRODUCTION.

THIS Class appears as the representative of the silk and velvet manufactures of the United Kingdom; the raw material of the manufacture being far more costly than in the two preceding instances of cotton and woollen. The articles included by this Class partake, on the whole, more of the character of products of luxury. The beautiful capabilities of the fibre for textile purposes, and its delicate applicability to the purposes of the dyer, render silk an interesting and attractive manufacture. The same qualities also combine to offer it as an admirable material for the display of taste and ornament. The number of Exhibitors rather exceeds that of those in cotton, but falls far below the number exhibiting in woollen and worsted. Manufacturers are the principal Exhibitors; but works executed by private hand, and articles exhibited severally by proprietors, have also a place in this Class.

The subdivisions of the Class are as follow:—A. Includes Silk Yarns, such as Spun, Thrown, and Sewing Silks; B. Plain Silks of every kind; C. Fancy Silks, as Shot, Figured, Embroidered, &c.; D. Velvets, Plain and Figured; E. Gauzes and Crapes; F. Plain Ribbons; and G. Fancy Ribbons.

The articles in the Class are to be found in the Building in the South and Transept Galleries, where they are contained in glass cases. In this position they offer a favourable opportunity for contrast with those of the principal foreign silk-producing localities, the contributions of which are displayed in the Central South Gallery, on the opposite side of the Transept.

The principal localities from which articles have been received have been the metropolis (Spitalfields), Macclesfield, Leek, Halifax, Derby, Manchester, Leeds, and Coventry. But many articles are exhibited which have not been derived directly from the locality occupied by the Exhibitor, but from others not enumerated.

The beautiful and artistic Silk Trophy, occupying the entrance to the Western Nave, cannot fail to attract notice. This trophy consists of an elegant arrangement of rich tissues, brocades, damasks, and other furniture silks, the whole of which have been manufactured by Messrs. Keith, & Co., and is surmounted by a silken banner. A variety of rich and costly productions of the Spitalfields loom are exhibited in the Galleries. The colours and textures of these fabrics are of great brilliancy and finish. An interesting collection of specimens of the raw and manufactured material is also exhibited. Specimens of silk-plush for various purposes, and in imitation of furs, are likewise found among these articles. The ribbons of Coventry have acquired a universal reputation; and this characteristic manufacture is well represented in the number and variety of these articles here exhibited. The application of steam power as a substitute for hand-weaving in this manufacture, is making rapid progress, and some of its results are apparent in this Class.

Attempts have been at different times made to introduce the breeding and culture of the silkworm into England, and with varying results. Some specimens of the results obtained by one of the most patient and persevering experiments are exhibited. This lady, now deceased, considered herself to have demonstrated the practicability of the introduction of this art into England. Silk of a beautiful kind has been produced, and calculations appear to indicate the possibility of the art being successfully prosecuted. A large banner of silk grown in England is exhibited. At present the United Kingdom draws its supply of the raw material for manufacture principally from the East Indies; and France, Italy, Turkey, and China, also supply a considerable amount. Ten years since the annual imports for home consumption amounted to the large sum of 4,734,755 lbs. When it is remembered that all this vast quantity of textile fibre is the result of the industry of larvæ, an idea may be gained of the importance of these things seemingly insignificant.—R. E.

1 KEITH, DANIEL, & Co., 124 Wood Street—
Manufacturers.

Silk trophy.—Rich tissues, brocades, brocatelles, silk damasks, silk and worsted damask, mayonettes, carriage-linings, diaphane, window blinds, and every variety of silks required for upholstery purposes. This trophy is represented in the accompanying Plate 65.

(Main Avenue, West.)

1A REDMAYNE, & Co., 20 New Bond Street—Inventors.

Figured taffeta and glacé gros d’Afrique, manufactured by Stone & Kemp, Spitalfields. Black gros de Tours, also of Spitalfields manufacture.

Garniture ribbon, manufactured at Nuneaton, by Cornell & Co. The wide ribbon requires a 900 Jacquard machine, and 1,700 cards to complete the pattern.

2 PUGH, J. W., 163 and 165 Regent Street.
Bombazeen cloth, for mourning. Widow’s silk.

3 SANDERSON & REID, 7 Gresham Street—Manufacturers
and Proprietors.

Specimen of silk weaving for a chair cover, combining velvet, satin, brocading, and tissuing with glass, to represent silver and gold (made under Messrs. Williams and Sowerby’s patent for tissue de vérre, or glass tissue).

New style of pattern and cloth for furniture. Finished pattern, forming a shape for wainscoating. Specimens for wainscoating, with variety of colours.

5 ROBINSON, J. & R. & Co., 30 *Milk Street, Cheapside*—Manufacturers.

Black and coloured velvets for vestings, and for church and upholstery purposes.

Black amozines for professional robes.

Plain silks and satins for vestings.

Silks and satins for cravats.

Figured silks for vestings and dresses.

Figured satin for fancy purposes, got up as a remembrancer of the Exhibition.

6 ROBINSON, J. & T., *Fort Street, Spitalfields*—Manufacturers.

Black and coloured velvets.

7 STILLWELL, JAMES, & SON, 7 *White Lion Street, Norton Folgate*—Manufacturers.

Samples of crimson, cerise, blue, and gold brocatelle, for curtains, &c. Samples of claret, green and gold, and cerise and white damask.

Pattern of Dalmatia robe, worn by the Queen, at her coronation.

8 WASHINGTON, T. & DAVIES, W., 13 & 14 *Milk Street, Cheapside*—Manufacturers.

Waistcoatings in lengths, of Spitalfields manufacture, in imitation of foreign furs.

9 WALTERS & SONS, *Wilson Street, Finsbury, and Kettering*—Manufacturers.

Specimens of plush used in the manufacture of silk hats.

10 WILSON, JAMES, & Co., 37 *Walbrook*—Manufacturers.

Silk plush for hats.

[A variety of causes, in addition to the scarcity of fur, have led to an entire change in the material for hats. At present, the greater number of hats are covered with a tissue of silk plush, laid over a stiff body. The silk plush forms the nap of the hat, and is manufactured in large quantities for this purpose.]

11 SWAN & EDGAR, *Piccadilly and Regent Street*—Proprietors.

Silks, &c., Spitalfields manufacture—Black gros de Naples, Ducape, gros de tour, glacé, satin, satin Grecian, barrathea, Balmoral, paraphanton, watered silk, velvet, armozine royal robe silk, gros royal, Radzimore, Berlin, Orleans, vest satin and antique watered silk. Manufactured by Messrs. J. Balance & Sons.

Coloured damask figured silk, new ground, manufactured by Messrs. Stone and Kemp. Coloured striped glacé and small check silks; coloured chiné silks, manufactured by Messrs. Winkworth & Procters.

12 DUTHOIT, JONATHAN, 26 *Steward Street, Spitalfields*—Manufacturer.

Brocade garment silks.

13 BOYD, ISAAC, *Spital Square*—Designer and Manufacturer.

Registered figured damask silk furniture, "hollyhock pattern;" white watered figured garment silk, "thistle, bell, and heather pattern;" blue tissue and gold figure garment silk, "pansy, lily, poppy, and rose pattern." "Moiré antique," for garments, various colours.

14 GREGSON & BRIEN, *Gresham Street West*—Agents.

Irish poplin or tabinet, plain, plaids, ribbed, double Irish, watered, and moiré antique. Manufactured by Mr. Wm. M. Geoghegan, 50 Francis Street, Dublin.

15 SEAMER, T., 5 *Milk Street, Cheapside*—Manufacturer.

Thirty-six inch moiré antiques, English dye and crimson velvet.

16 LEWIS & ALLENBY, 193, 195, & 197 *Regent Street*—Designers.

Silk, brocaded with colours. Designed by S. W. Lewis. The beauty and difficulty of production of this silk will be more readily understood from the fact that its manufacture requires the use of nearly 30,000 cards and 100 shuttles, and it is stated to be the first instance in which a brocade, introducing so large a number of colours (fifteen), has been successfully attempted in England. Manufactured in Spitalfields.

Brocaded ribbons.

17 GRAHAM, ROBERT, & SONS, 31 *Spital Square*—Manufacturers.

Velvet, satin, and watered silks.

18 STONE & KEMP, 35 *Spital Square*—Manufacturers.

Velvets. Figured and chiné silks.

19 SEWELL, EVANS, HUBBARD, & BACON, 44, 45, & 46 *Old Compton Street*—Proprietors.

Registered figured damask silk, brocaded in various colours, manufactured by Messrs. Campbell, Harrison, and Lloyd, Spitalfields.

Plain moiré antique.

Registered figured damask made in a Jacquard and Bannister loom, by Messrs. Winkworth and Procters, Manchester.

20 CLARK, JANE, 170 *Regent Street*—Designer and Manufacturer.

Spitalfields enamelled silks, viz.—

A white ground, covered with gold baskets filled with green enamel shamrocks.

A white ground with rainbow enamel.

21 LE MARE, JOSHUA, & SONS, 27 *Spital Square*—Manufacturers.

Black satinette, of inferior quality, woven by power-loom, and of superior quality, woven by hand-loom.

Coloured satinette, of medium quality, woven by hand-loom.

The advantage of satinettes over satins consists in their brilliancy being produced in the process of manufacture, without dress or any other artificial means; consequently they are as cheap and more durable.

Black ducape, watered, of large and small patterns and medium quality.

Black coloured velvet, of medium quality.

22 CORNELL, LYELL, & WEBSTER, 15 *St. Paul's Churchyard, and Nuneaton*—Manufacturers.

Chiné and brocaded sash and other ribbons.

23 CASEY, J., & PHILLIPS, T., 13 *Spital Square*—Manufacturers.

Silk, velvets, Algerias, gros-de-Naples, glacé, gros, &c.

24 ROBINSON, JAS. & WM., & Co., 3 and 4 *Milk Street, Cheapside*—Manufacturers.

Crimson velvet for pulpits.

Blue and marone velvets for waistcoats.

Brown and blue plush for coats and vests.

White satin and white tabby silk for embroidery.

White and black satins for shoes.

White and black satins for vests.

White watered and figured silks for waistcoats.

Black serge and white laventine for coat sleeve and skirt linings. Black amozines for robes.

- 25 HILL, JAMES, & Co., 30 *Spital Square*—Manufacturers.
Registered oak and ivy brocaded silk, manufactured by Jacquard machines.
Silk velvets. Shot glacés, woven by Spitalfields handloom weavers; the colours all British dyes.
Black satin. Brocaded figures.
- 26 BROOKS, THOMAS, 26 *Spital Square*—Manufacturer.
Marguerite, Napoleon blue, green and black velvets.
Black gros-de-Naples.
Sky, pink, and Napoleon blue Sutherland silk.
Adelaide and chocolate brown satin.
- 27 HOWELL, J., & Co., *Regent Street*.
Two richly embroidered silks, manufactured by Campbell & Co., Spitalfields. Rich chiné, 12 inch, and rich brocaded sash ribbons.
- 28 VANNER, J., & SON, 15 *Spital Square*—Manufacturers.
Silks for parasols, tabby ground, with satin and rip figure.
Specimen of new texture for parasols, with figured middle.
Glacé silk, figured, for parasols. Rip figure for the same.
- 29 SOPER, HENRY, 32 *Spital Square, Bishopsgate Street*—Manufacturer.
Silk for parasols; satin and figured borders, shot with Bengal silk; figured satin and damask rip and ducape.
Improved silk for umbrellas.
- 30 CARTER, VAVASEUR, & RIX, 9 *Trump Street, Cheapside*—Manufacturers.
Figured poplin dress. Figured satin dress.
Figured satin, brocaded with many colours.
Maize moiré antique. Napoleon blue satin.
- 31 CAMPBELL, HARRISON, & LLOYD, 19 *Friday St.*—Manufacturers.
Figured moiré antique damask. Scotch tartan satins and velvets.
Coloured moiré antique. Brocade figure for vestings.
- 32 CROSS, CHARLES, 19 *Gutter Lane, Cheapside*—Manufacturers.
Specimen of Jacquard silk weaving, 29 inches by 24, portraits of Her Majesty the Queen, and H.R.H. Prince Albert, with emblematic decorations.
Figured satin cravats; figured cravats (not satin).
Satin checked bandannas, various widths.
Satin checked Brussels, various widths.
Black bandannas, corded and plain borders, various widths.
Black ducaupes; black Brussels twill; black military twill; and black barathea twill, all of various qualities.
Black glacé, different widths.
Black watered ducaupes.
Paris checked bandanna.
China twilled bandanna, plain and printed.
Grey twilled bandanna, plain and printed.
Samples of silks, raw, China, Bengal, and Italian.
Samples of silk, thrown, gum boiled off, and dyed.
- 33 MARSHALL & SNELGROVE, 11 and 15 *Vere Street, Cavendish Square, and 19 Henrietta Street*—Proprietors.
Broad silks—Shaded glacé silk of British manufacture (by Messrs. Winkworth and Procters, of Manchester), displaying the variety of hues in each shade of colouring. The number of threads to each shade is near two thousand, divided into about twenty tints in the dyeing, and again intermixed in varying proportions throughout.

In addition to the effect of shading, these goods have undergone the process of antique watering.
Ribbons, manufactured at Coventry (by Messrs. Cox and Co.); the design, by the exhibitors, representing a bunch of lilac, made in a Jacquard loom. Shaded ribbons.

- 34 COURTAULD, SAMUEL, & Co.—Manufacturers.
Specimens of crape and aerophane, in the principal varieties of quality and style.
- 35 MASON, GEORGE, *Yateley, Hartford Bridge, Hants*—Producer.
Figured damask silk, grown and wound off at Yateley, North Hants; an agricultural experiment.
English cloth, embroidered with silk, grown and wound off at Yateley. Manufactured by Messrs. Houldsworth, Manchester, with their patent machinery, which embroiders both sides of the cloth alike.
Fishing gut, from imperfect silkworms.
Waste silk, from cocoons.
- 36 GROUT, JOSEPH, & Co., *Foster Lane*—Manufacturers.
Folded and rolled black crape, single, double, treble, and four threads. Coloured aeroplane crape.
Coloured lisse gauze. Gossamer of various colours, used for veils.
Samples of crêpe lisse. Silk gauze grenadine scarf; and brocaded. Silk muslin scarf; and brocaded.
Brocaded silk muslin dress, with flounces, &c.
- 37 DEAR, ARTHUR, 37 *Crispin Street, Spitalfields*—Agent.
Figured silks, designed and woven by the pupils of the Spitalfields School of Design.
- 38 BROCKLEHURST, J. & T., & SONS, *Macclesfield*—Manufacturers.
Raw silk, reeled. Thrown silk and dyed silk.
Sewing silk in raw and dyed state, spun silk, from refuse knubs and husks, exhibiting the material and its stages in process, consisting of yarn, cops, and goods.
Manufactured goods:—Velvets, satins, moiré antiques, glacé gros de Naples (figured and plain); levantines, serges, vestings, sarsnets, Persians, ribbons, hat and railway carriage furniture.
Ladies' and gentlemen's black, coloured, plain, and figured handkerchiefs, scarfs, shawls, &c. Gauze veils.
- 39 ADSHEAD, W. & Co., *Macclesfield*—Producers.
Silk dyed in the skein, and prepared for the use of the manufacturer.
- 40 CRITCHLEY, BRINSLEY, & Co., *Macclesfield*—Manufacturers.
Silk in the manufactured state.
Ladies' foulard dresses, aprons, neck-ties.
Gentlemen's cravats and boys' neck-handkerchiefs.—Designs registered.
- 41 WARDLE, HENRY & THOMAS, & Co., *Macclesfield*—Manufacturers.
Ladies' silk handkerchiefs, plain and checked, figured and chiné.
Boys' cravats.
Gentlemen's pocket handkerchiefs and cravats.
Ladies' small silk shawls.
- 42 HADWEN & SONS, *Kebroyd Mills, near Halifax*.
Manufacturers.
Illustrations of the production of waste silk from the eggs of the silk-worm. Cocoons in the bush; the cocoon as left by the worm; the waste of the cocoon in the brush. Specimens of raw material: waste silk in the

dressed and carded state; the same in the slubbing and thick roving, and in fine rovings. Single and double spun silk yarns.

43 STUBBS, POWNALL, *Leek*—Manufacturer.
Needle-worked silk buttons.

44 BROUGH, JOSHUA, JAMES, & Co., *Leek*—Manufacturers.
Sewing silks, raven and jet black.
Purse or netting silk.
Leger twist, in balls. Silk twist, in balls and reels.

45 HAMMERSLEY & BENTLEY, *Leek*—Manufacturers.
Twist of various colours, in balls and on reels, for tailors. Italian sewings, for tailors and milliners. Purse twist. Black silk twist, in hanks, for tailors.

46 WESTON & SON, *Leek*—Manufacturers.
Various buttons, including Florentine, brown Holland, real twist Italian, white cotton and worsted, netted silk, silk barrel, rich twist (needlework dome), rich twist, youths' dress silk, silk fancy vest, and ladies' silk dress.

47 DAVIDSON, JOHN, & Co., *Leek*—Manufacturers.
Raven, jet, and drab cloth sewing silks for tailors.
Jet, drab, and coloured silk twist.
Jet and coloured sewing silk for milliners. Stay silk.
Veil, vest, and shawl embroidering silk. Saddlers' silk.
Black, white, and coloured floss silk.
Tram, for figuring, embroidering, or weaving.
Boot-closing. Purse twist. Silk serge.

48 ALSOP, ROBINS, & Co., *Leek*—Manufacturers.
Black and coloured silk serges. Black silk handkerchiefs.
Black 20 handfacing, double plain, watered, and plain and watered.
Black Prussian bindings. Black and coloured galloons.
Black sewing silk, and black and coloured twist, in alls and reels, dyed by W. Hammersley & Co., *Leek*.
Coloured purse or netting silk.
Yellow weaving, or barber's twist.
Silk whip-lashes. Needlework buttons.

49 BRIDGETT, THOMAS, & Co., *Derby*—Manufacturers.
Specimens of sewing-silk for saddlers, bookbinders, staymakers, tailors, &c., netting or purse-twist, and plain sarsnet ribbon.

50 ALLEN & HOLMES, *Derby*—Manufacturers.
Black silk ribbons and braids. Algerines. Black satin trimmings. Silk warp, prepared for the manufacture of various fabrics.

51 SMITH, MARY, 3A *Abbey Street, Bethnal Green*—Designer and Manufacturer.
Chenille shawl, made of choice silk, and manufactured in a loom made for the purpose. Exhibited as a specimen of manufactured chenille, and as a useful article for wear and warmth.

52 GROSVENOR, WILLIAM, *Kidderminster*.
Manufacturer.
Silk brocade, brocatelle, and figured satinet damasks, for upholstery.

53 PULLING, JAMES, 6 *Brudenell Place, New North Road*—Manufacturer.
Trains of crape tunics and tucks.
The Lady Peel mantle.
Train trimmings in graduated sets.
Elizabethans. Berthas.

54 WRIGHT, P. & R., *Edinburgh*—Designers and Manufacturers.
Figure of the Duke of Wellington on horseback, in silk damask.

56 WILSON, JOHN, 5 *Church Passage, Spital Square*—Manufacturer.
Mourning hat-band, manufactured of silk, woven circularly, and sufficiently elastic to fit over the hat.

57 BURKE, THOMAS HASWELL, 6 *Bull Head Court, Newgate Street*—Manufacturer.
Embossed silks, velvets, &c.; ladies' sashes and flounces; and trimmings for mantles, dresses, millinery, and parasols.
Model of the Exhibition Building, embossed, about four feet six inches long.
Victoria mounts for the decoration of drawings and prints.
Embossed lace papers, hand-screens, card-racks, folios, ornaments for dining-tables, and various other articles.

58 GREENSHIELDS, WALTER, *Whitburn, Linlithgowshire*—Manufacturer.
Specimens of ornamental work, accomplished without the aid of a needle.

59 PENFOLD, O., 4 *Blackmoor Street, Clare Market*—Manufacturer.
Gauze diaphane for covering looking-glass and picture frames, &c.

60 EVANS, SAMUEL, *Wirksworth, Derbyshire*—Manufacturer.
Specimens of silk plush for vestings.

61 HOLDFORTH, J., & SON, *Leeds*—Spinners, Inventors, and Importers.
Various specimens of the article known as silk waste, Chinese, Italian, and British.
Specimens of single and double spun silk yarns, from the coarsest to the finest numbers, the finest having 423,400 yards to a pound (No. 510 cotton reel), and is used to a great extent for the manufacture of a variety of goods.
Samples of silk yarn, dyed and finished, ready for the manufacturer. Spun by the exhibitors' patent process, by which greater brilliancy and strength are said to be obtained, and a very near approach to net silk, for which it is substituted for a variety of purposes.

62 HARROP, TAYLOR, & PEARSON, *Piccadilly, Manchester*—Manufacturers.
Pink, white, sky, and maize gros de Naples for ladies' bonnets; exhibited for cheapness.
Black gros de Naples and ducales, for ladies' dresses.
Black edged ducape, 22 inches tape edged armaine and black velour for hat-bands, scarfs, and clergymen's gowns.
Gros d'Ecosse, various mixtures, used for ladies' dresses, mantles, &c.

63 BOOTH & PIKE, 43 *Oldham Street, Manchester*—Manufacturers.
Imperial or carded plush for hats, bonnets, &c., in the various stages of manufacture: viz., 1st, grey, as it leaves the loom; 2nd, as it appears after the nap has been raised partly by hand and partly by steam-power by means of teasels and cards; 3rd, the same with the nap shorn of a uniform length; 4th, black, as received from the dyer; and, 5th, when finished and ready for use in various colours.
Galloons, or bindings and bands with the buckles attached, ready for the hat.
Hat linings, of various qualities and descriptions, with specimens of the same in the piece.

64 HOULDSWORTH, JAMES, & Co., *Portland Street Mill, Manchester*—Designers and Manufacturers.
Specimens of Jacquard figured silk fabrics, suitable for furniture, consisting of silk tissue, brocades, brocattelles, &c.

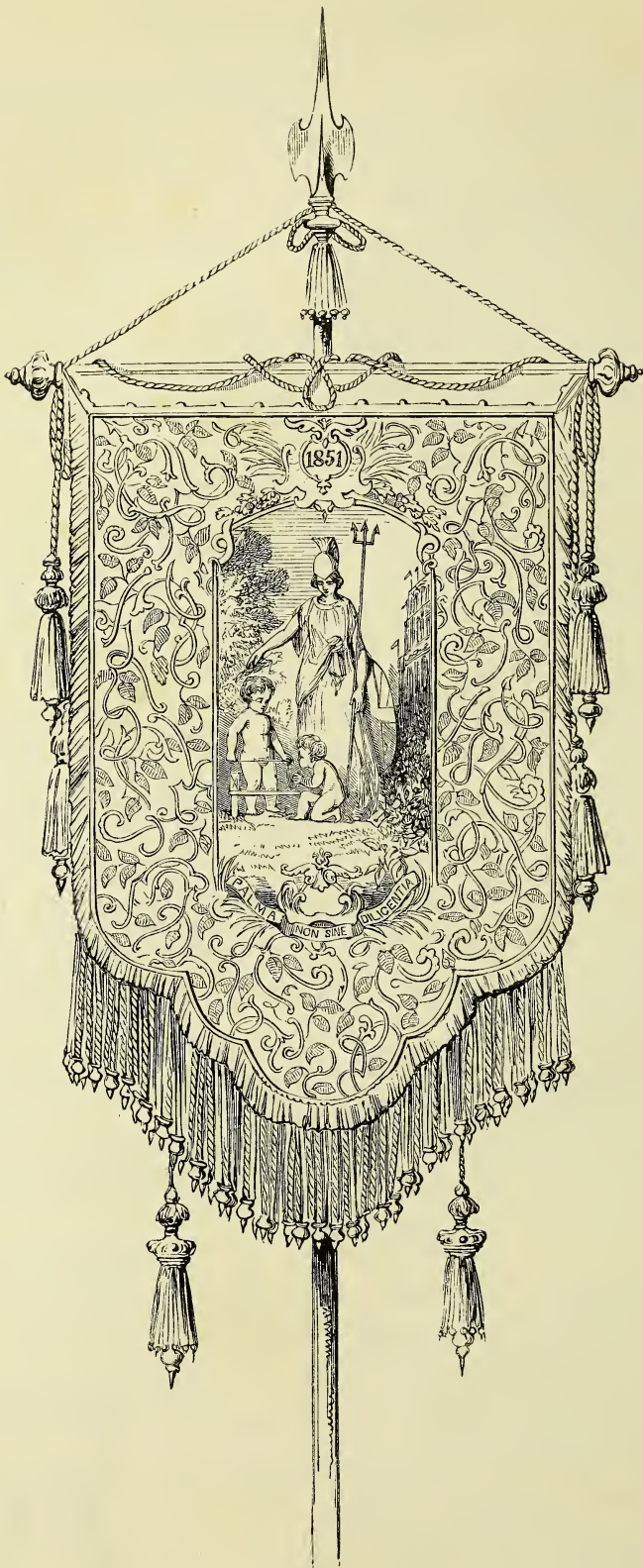

91. BANNER OF SILK, PRODUCED IN ENGLAND BY THE LATE MRS. WHITBY. J. HOULDSWORTH AND CO.

Specimens of patent machine embroideries, consisting of quilts, table-covers, curtains, panels, medallions, &c. The centre portion of the large satin quilt, and the various specimens of panelling, are exhibited as novelties.

British silk banner, and sundry specimens of cocoons, raw silk, &c.

Banner, composed of silk grown and manufactured in England for Theresa John Cornwallis West, Newlands, Lymington, Hants.

This banner is represented in the accompanying Plate (91).

The filling all round the centre group of figures, is a trail pattern, composed of the mulberry leaf and twig, entwined with an ornamental scroll. On a blue ribbon is the motto "Palma non sine diligentia." This and two lengths of satin damask, wrought in medallions from the antique, are the result of fourteen years' untiring and intelligent perseverance in the endeavour to breed silkworms successfully for commercial purposes in England. This labour was voluntarily undertaken by the late Mrs. Whitby of Newlands, in the county of Southampton. The worms were born and raised at Newlands, and the silk wound by her own people. The mulberry plants that fed them, which were grown in a field on the estate, are of the Philippine variety, *Morus multicaulis*, and were imported by Mrs. Whitby, from Turin.

[In 1846, the late Mrs. Whitby communicated the results of experiments carried through 10 years, in the endeavour to prove the possibility of profitably rearing the silkworm in England. She commenced her experiments by ascertaining the best variety of mulberry-tree. That which subsequent experience led her to believe to be best suited for this purpose was the *Morus multicaulis*, of the Philippine Islands. This variety was introduced by herself in 1846. The weight of leaf borne by this variety is very great, and it admits of easy propagation in open ground. With care, and an abundant supply of manure, the size of leaf attained in Hampshire was very great. The eggs employed were of the large Italian sort. After much patient experiment, Mrs. Whitby became convinced that the silkworm could be as easily reared in England as in any other country, and with as little loss. Equable warmth throughout the period of the insect's existence, cleanliness, classification, and ventilation, with due attention to the suitability of food to the age of the insect, are stated as the essential elements of successful management. The silk produced was pronounced by the most eminent manufacturers equal, and in some specimens superior to the best Italian silk, and Mrs. Whitby also considered she had proved that the cultivation of silk in this country could be pursued as a profitable undertaking. Several attempts have been and are now being made in imitation of the labours of this lady, and beautiful fabrics have been woven of silk of home-produce.—R. E.]

65 WINKWORTH & PROCTERS, Manchester—Manufacturers.

Figured silks of different designs and character. Chiné silk, striped all over, and watered; and plain silk of various kinds and qualities.

66 COX, R. S., & Co., 7 St. Paul's Churchyard, and Coventry—Manufacturers.

Two rich sashes and other ribbons.

The designs of two of the sashes are taken from Paxton's "Flower Garden." The one, 7 inches wide, "The glittering gland-bearing trumpet-flower" (*Adenocalymma*

nitidum). The other, 5 inches wide, "The oval and the pallid hoyas" (*Hoya ovalifolia* and *pallida*).

67 BRAY, CHARLES, & Co., Coventry—Manufacturers.

Ribbons illustrative of the ordinary Coventry ribbon manufacture.

68 CALDICOTT, R. & R., Coventry—Manufacturer.

Ribbons: specimens of Coventry manufacture.

[The staple trade of Coventry is the manufacture of ribbons and of thrown silk, established now about a century and a half in that town. A large number of hand-looms are concerned in ribbon-weaving, many being at work in the homes of the weavers. Of late, steam power has likewise been employed. The ribbon trade of Coventry exceeds that of any other town in the United Kingdom.—R. E.]

69 SHARP, ODELL, & JURY, Coventry—Manufacturers.

Ribbons, illustrative of a medium quality of goods manufactured at Coventry.

70 COPE, HAMMERTON, & Co., Coventry—Producers.

General fancy ribbons.

72 COVENTRY RIBBONS COMMITTEE—Producers.

Specimens of Coventry ribbons.

73 RATLIFE, JOHN, & CLEOPHAS, Coventry—Manufacturers.

Ribbons illustrative of the ordinary Coventry manufacture.

Plain satin, striped or vellum satin, and plain and pure edged lutestring ribbons; white simple fancy ribbons; coloured simple fancy ribbons, for summer and winter.

75 BERRY BROTHERS, Coventry—Manufacturers.

Figured ribbons, &c., manufactured by steam-power. Ribbon trimmings, for dresses, exhibited for cheapness.

76 HART, J., Coventry—Manufacturer.

Group of ribbons, exhibited for cheapness of production.

77 ROBINSON, THOMAS, Coventry—Manufacturer.

Figured satin ribbons, produced by steam-power. Figured lutestring ribbons; cut-edged ribbons. Rich brocaded ribbons made by patent brocading batten, by steam. Watered pad ribbons.

Half China ribbons, used for tying up cambrics, gloves, &c.: this is the narrowest woven fabric made in silk.

78 McRAE, JOHN, Coventry—Manufacturer.

Mourning gauze; crape, love, and rich figured lutestring ribbons.

79 STURDY & TURNER, Coventry—Manufacturers.

Samples of ribbons, exhibited for design, and the application of steam power to its manufacture.

Ribbons exhibited for design and execution.

Specimens illustrative of a peculiar quality of white ribbon.

80 BROWETT, W. & H., Coventry—Manufacturers.

Bullion fringes for dresses or cloaks; sewing silk fringes for dresses; mohair fringes for cloaks; black fancy bullions and fancy sewing silk fringes for cloaks.

Silk brace webs; silk belt webs for children.

Ladies' fancy belts. Black hat bindings.

Gimp and fancy trimmings for dresses.

Samples of dyed silks and cottons used in the above manufacture.

[To the Chinese we owe the knowledge of the manufacture of silk; but its origin, even with them, is hid in remote antiquity. Silk was brought overland from China to Rome, within a century after Alexander had opened the passage to India. In the reign of Aurelian, A.D. 270, its price was so high, that a pound of silk was sold for a pound of gold, nearly equal to 50*l*. About a century later its purchase was within the reach of all classes at Rome; and in the reign of Justinian, A.D. 551, by the agency of two Nestorian monks, who brought the eggs of the silkworm from China, the manufacture of silk was introduced into Europe. Venice and Lyons afterwards took the lead in its European manufacture; and the revocation of the edict of Nantes brought the first silk weavers to Spitalfields in 1685.

Silk is still imported from China, and it excels that of every other country, in brilliancy and colour. Considerable quantities are also imported from France and Italy; the silk of the latter country being esteemed the superior. The silk manufacturers of England have successfully striven under many disadvantages (one of which has been the difficulty of raising the raw material at home), to cope with the continental manufacturers in the production of elegant fabrics, and they now produce some which rival, if they do not surpass, those of foreigners. Manchester, as an example, exhibits "gros de Naples" as good and as cheap as that of Lyons; and the establishment of our Schools of Design bids fair to secure our superiority in the taste and beauty of our patterns.

Of the various kinds of silk fabrics presented to our notice, we can only describe a few. Damask, which was formerly used for dresses, is now chiefly employed in furniture; it is a twilled fabric made in the same manner as linen damask, with flowers, birds, and other ornaments worked into its texture. Brocade is a fabric into which, originally, threads of gold and silver or a mixture of these were introduced to increase the richness and splendour of its appearance. This name, however, is applied to rich silk stuffs, as satins, taffetas, lutestrings, &c., adorned with flowers and figures. Satin is a glossy silk twill to which the soft and glistening appearance is given by rendering a great number of the threads of the warp visible in the process of weaving; instead of raising

each half of the warp alternately, only a fifth or an eighth part is raised, so that the face which is thus woven downwards, presents an even, close, and smooth surface. To improve its appearance, when taken out of the loom, it is rolled on heated cylinders which renders the face still more smooth, and imparts to it a more brilliant lustre. The smooth and plain fabrics, as lutestring, gros de Naples, Persian, ducape, levantine, sarsenet, &c., differ from each other chiefly in their thickness and quality. Some of these, however, are figured. Taffety is a fabric of a wavy lustre imparted by pressure and heat, with the application of an acidulous liquor which produces the effect called watering. Tabby and tabbinets are varieties of the latter. Armozeen is a thick plain silk, generally black; used for clerical and funeral purposes.

Velvet is distinguished by the soft pile on its surface, which is produced by the insertion of short pieces of silk thread doubled under the weft, and so crowded together as entirely to conceal the interlacings of the warp and weft. The loops of the thread are afterwards cut, and then they exhibit the appearance of a brush; the pile is produced by the separation of the threads, and the application of machinery to cut them smooth and even. The warp and pile of good velvet are both composed of organzine silk, which is composed of several threads of raw silk twisted or *thrown* together in the form of a rope; and its richness depends upon the relative numbers of its pile threads. Velvets are said to be of different degrees of richness, viz., of two, four, or six threads, according to the number of pile threads inserted between each of the dents of the reed. The velvets of Spitalfields may be safely compared with foreign velvets in fineness and strength, as well as in general appearance.

Ribbons, or, more properly, ribands, are chiefly made at Coventry, and have of late so much improved in manufacture, that our home producers can now vie with the foreign. They partake of the same varieties in general, as the larger silk fabrics; they are frequently ornamented with a pearl edge, which is formed by making some of the threads of the weft project beyond the rest. Clouding is an appearance given to ribbons in the dyeing.—R. W.]



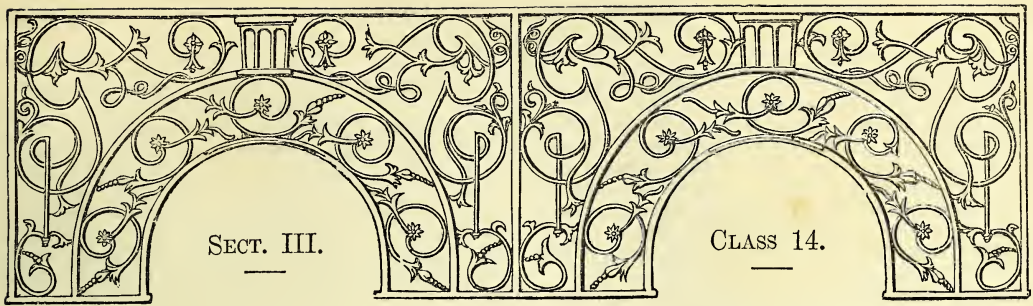

FLAX AND HEMP.

INTRODUCTION.

FLAX and Hemp formed the staple material for vegetable textile manufactures in the United Kingdom long prior to the development of the cotton trade. The application of cotton, in its present extensive degree, is altogether modern; and this material has already, in many instances, entirely, and in others in part, replaced flax and hemp, and the substitution is continually proceeding in fresh directions. For many purposes, however, cotton does not appear to offer itself as a probable substitute for the materials concerned in this Class. The remarkable difference in the conducting properties (for heat) possessed by cotton and flax alone seems to assign a separate use to them in textile manufacture, which, coupled with their different physical and mechanical properties, will probably always render their employment in textile fabrics distinct.

The Class comprehends the following Sub-Classes:—A. Flax-fibre, in its various conditions, as Steeped and Unsteeped, Heckled, &c.; B. Linen Yarn and Thread; C. Plain Linens of all widths, Bleached, Unbleached, and Dyed; D. Damasks, Diapers, Drills, and other Twilled Linens; E. Cambrics, Cambric and Linen Handkerchiefs, Lawns, &c.; F. Cordage of all kinds.

The position occupied by the objects in this Class in the Exhibition Building is near the Western Entrance, on the south side of the Nave, Ground Floor. The Areas devoted to their reception are L. and M. 6 to 8, and N. and O. 4 to 6. On the North Wall, also, in a recess near the flax machinery, in Class V., are placed specimens of heavy canvas, sail-cloth, &c., and in a part of the space occupied by Class XI., will also be found various manufactures belonging to the present Class.

A great variety of damasks of different kinds are exhibited. The design of several of these represents in a forcible manner the success with which the Jacquard principle is applied to the ornamentation of fabrics for ordinary use. The localities supplying these and similar articles are chiefly Belfast, Dunfermline, Barnsley, and Manchester. Some interesting collections of the materials used, and of its first stages of preparation for manufacture, are likewise shown. The most ordinary articles such as sacks, threads, fishing-nets, ropes, and twine, have all a place of interest and importance in this Class. The heavier descriptions of flax manufactures are supplied chiefly from Dundee, Hull, Greenock, and Arbroath. The machinery necessary to weave some of these productions, such as sail-canvas, sacking, &c., presents a forcible contrast by the size and power of its parts to the lighter and more elegant machines employed for weaving the fine cambrics used for pocket-handkerchiefs.

Specimens of articles manufactured from different kinds of flax and hemp will also attract notice, and illustrate the peculiar applicability of these sorts for different fabrics. *Jute*, a fibrous material of recent introduction from the East Indies, is becoming extensively employed, particularly for carpetings, sacking, bags, &c., in which a fine material is not necessary. The beautiful flax prepared at Courtrai, and adapted exclusively for the most delicate fabrics, is employed in the manufacture of many of the articles exhibited. British, Russian, China, and Manilla hemp, enter into the composition of others.

In 1841, upwards of one million and a quarter cwts. of flax and tow were imported into England at a duty one penny a cwt., yielding consequently about 5,500*l.* to the revenue. The flax factories in the United Kingdom are of great size and importance, and employ a large number of operatives in immediate or indirect connexion with them. If it should become possible to obtain cheaply an adequate supply of flax of home production, and of the fit quality for the purposes of the spinner, the dependency of this country upon the East and America for cotton as a textile material would be greatly lessened, and an important field of commercial activity would be laid open at our own doors. But the properties of flax, and the tedious processes necessary for its preparation, have hitherto proved an obstacle to its more extensive employment. A variety of experiments on this subject are however in progress, the ultimate result of which can scarcely be foreseen; and it appears already to have been proved by actual trial that this fibre can, after preparation, be applied to the ordinary machinery of the cotton-mill, yarn having been spun up to moderate numbers from flax thus prepared. Until recently flax cultivation has scarcely been fairly attempted; but it seems probable that in a short time extensive, and it may be hoped successful, trials will be made to supply this country with a manufacturing material so intrinsically valuable.—R. E.

1 HOLDEN, JOHN, & Co., *Belfast, Ireland*—Designers and Manufacturers.

Sewed book muslin, jaconet and book frill collars; sewed book capes. Ladies' caps, tamboured. Infants' caps, sewed cambric, and sewed book. Infants' frock bodies. Fancy habits. Infants' robes. Chemisettes. Cambric and book insertion. Cambric and book edgings. Sewed book sleeves and flouncings. Sewed cambric flouncings. Linen cambric handkerchiefs. Polka jackets.

2 BROWNS, JOHN R. & WILLIAM, *Bangor, County Down, Ireland*—Manufacturers.

Lady's robe, and baby's robe, embroidered muslin.

3 DUFFERIN's, Lord, School, *Belfast*—Producer.

Embroidered handkerchiefs, worked by peasant girls.

4 PELLING, CHARLES, 81 *Academy Street, Belfast, Ireland*—Inventor and Manufacturer.

Ladies' embroidered muslin robe, designed by M. M'Kinsie, Belfast.

Irish cambric ornamented gentlemen's shirt fronts.

5 ANDREWS, MICHAEL, *Royal Manufactory of Linen and Damask, Ardoyne, Belfast, Ireland*—Manufacturer.

Table cloth of new pattern, to be presented to the Earl of Clarendon by the Royal Society for the promotion and improvement of the growth of flax in Ireland. The centre represents the star of the Order of the Garter, in a union garland of rose, shamrock and thistle, interspersed with flax, and surrounded by the jewels of the Order of the Bath and St. Patrick, with Irish harps in shamrock wreaths. At each end is a presentation piece from the Royal Flax Society, Belfast, 1851, on a group of shamrock and flax, surrounded by the Clarendon arms, incorporating the collar and jewel of the Order of St. Patrick, with the motto and jewel of the Order of the Garter. The border exhibits a rich collection of flowers, drawn from nature. The ground consists of four large amaryllids around each representation of the arms, with small sprigs of shamrock and flag intertwined, &c.

Table cloth of new pattern, designed by John Mackenzie, Government School of Design. The centre consists of a rustic stump and basket of rich flowers, resting on a group of flowers at the base, and supported by an Arum and a Strelitzia, surrounded by a light wreath of flowers, chiefly climbers, and a ground harmonizing in same style. The border represents a rich scroll, each compartment terminating with distinct flowers. The corners represent the rhododendron in flower, the end and side the centres of flowers. The margin represents the hearts-ease, on leaves of the same.

Table-cloth, extra double damask, with arms of Goldsmiths' Company of London for centre, flowers with sprigs filling, in a scroll and flower border.

Table-cloth, extra double damask, with arms of Baron Rothschild for centre, surrounded by various sprigs, and border of flowers.

Table-cloth, extra double damask, with arms of Mr. Wheble for centre, surrounded with sprigs, and encircled by two flowing scroll borders.

Table-cloth, extra double damask, being pattern of a rich table service of various lengths, manufactured for Her Majesty's 62nd Regiment of Foot, showing the number in a large star, surrounded by a flowing riband containing the names of the battles in which this regiment obtained honours, with sprigs, the whole enclosed by a border of oak and laurel intertwined.

Piece of extra double damask, containing twenty-four doyleys, being six different patterns and four doyleys of each pattern.

All in an unbleached state as they come from the loom.

6 BELL, THOMAS, & Co., *Belview, Lurgan, Belfast*—Manufacturers.

Samples of cambric bordered handkerchiefs, clear lawn, and plain cambric.

7 RICHARDSON, SONS, & OWDEN, *Belfast, Ireland*—Manufacturers.

Double damask table-cloths, with border, roses, shamrocks, and thistles, Irish wolf-dog and harp; corner-piece, shield of oak leaves, flags, anchors, and a dove encircled in palm wreaths with olive branch; side range, tray-scroll, Prince of Wales's feathers, in oak wreath; and centre range, a temple, British royal arms, vase of flowers, &c. Designed by William John Magee, Lisburne, Ireland.

Double damask cloth. Samples of Irish linens, ranging from a coarse quality to the finest; of light linens, ornamented for the export trade; and heavy linen, in the brown state.

8 FLETCHER, ALEXANDER, *Glasgow*—Manufacturer.

Various patent linen threads.

9 LEADBETTER, JOHN, & Co., *Belfast, Ireland*—Manufacturers.

Linen drill, brown, bleached, and dyed. Fancy drill, plain checks and stripes, all linen, and mixed. Linen creas, platillas, and hollands, brown and dyed.

10 KIRK, WILLIAM, & SON, *Annale, near Keady, Ireland*—Manufacturer.

Rough brown linen. Brown, natural drab, dyed drab, slate, and black linen hollands. Bleached linen diapers; lining, family, and fronting linens; and unions.

11 BENNETT & ADAMS, *Coleraine, Ireland*—Manufacturers.

Fine linen.

12 ADAMS, JANE, *Strabane, Ireland*—Manufacturer.

Needle-work scarf, apron, collar, and cuffs, made of linen yarn, in imitation of lace.

13 CRAWFORD & LINDSAYS, 3 *Lawrence Lane, Cheapside*—Manufacturers and Bleachers.

Specimens of white and brown linen sheeting; damask table linen, &c.

14 CARSON, R., *Randalstown, Belfast*—Manufacturer.

Woad, bleached, and unbleached linens.

15 PINKERTON, JAMES & ROBERT, *Ballymoney, Ireland*—Manufacturers.

Fine linens.

16 HENNING, JOHN, *Cambray House, Waringstown, Banbridge, County Down, Ireland*—Manufacturer.

Samples of handkerchiefs; linen cambric; "silken flax;" "golden flax;" Irish cambric hem-stitched; embroidered; and with printed borders.

Printed linen cambric dresses; and lawns, straw colour; shirt frontings; satin damasks, bleached; napkins; double satin damasks, grey warp, white weft, and slips; satin damask gold and white dessert cloths; gold and purple, and other coloured table covers.

Damask coronation cloth, manufactured in Waringstown, in 1717; sketch of the cloth, to show the pattern; piece of brown cambric.

Satin damasks, butterfly pattern, scroll border, Portland vase, scroll border and fancy centre.

Reed for weaving cambric, 5,000 splits to the yard; manufactured by Marmaduke Carmichael, Lurgan.

Handkerchiefs from China grass.

Cambric loom; damask loom; machine for weaving damask, or other figured fabrics, on the Jacquard principle.

17 BROWN, JOHN, & SONS, *Waringstown, Banbridge, Ireland*—Manufacturers.

Double damask napkins and table cloths, various patterns. Unbleached damask.

18 SADLER, FENTON, & Co., *Belfast, Ireland*—Manufacturers.

Samples of Irish flax seed. 1. Flax plant, fully ripe. 2. Scutched, or the woody part removed. 3. Heeked, or prepared for spinning; and 4. Mill-spun and hand-spun yarn.

Specimens of strong medium, and light brown Irish linen; and various other kinds. Also fronting, medium, light, and slate linen. Linen and brown sheeting. Irish linen creas. Linen britannias. Estopillas. Linen silesias and platillas. White, brown, and slate linen drills.

19 M'CAY, THOMAS, *Lisnashenker, Dromore, Ireland*—Manufacturer.

Bleached linen, from hand-spun and mill-spun yarn. Brown linen-warp, mill-spun; weft, hand spun. Linen mosquito nettings, all mill-spun yarn.

20 CLIBBORN, HILL, & Co., *Banbridge, Ireland*—Manufacturers and Bleachers.

"Bird's-eye" diapers, manufactured from the best quality of linen yarn.

21 RICHARDSON, J. & T., & Co., *Springfield, Lurgan, Ireland*—Manufacturers.

Irish cambric handkerchiefs, plain, hem-stitched, printed, and wreathed.

22 MALCOLM, JAMES, *Lurgan, Ireland*—Manufacturer.

Linen cambric, clear lawn, and hem-stitched handkerchiefs. Shirt frontings. Lawns. Handkerchiefs of fine handspun yarn, 70 hanks to the pound.

23 RICHARDSON & Co., *Lisburn, Ireland*—Manufacturers.

Samples of Irish linen.

24 CORRY, BLAIN, & Co., *Belfast, Ireland*—Designers and Manufacturers.

New damask table-cloths. The ornaments are raised so as to have the appearance of being embossed, rather than woven. The designs are imitation of foliage and flowers; and scroll border, the centre a Medici vase, encircled with foliage and flowers. Specimens of double damask tray-cloths.

Specimens of steam-power loom manufacture; applied to damask table linen. Damask table-cloths, various designs. Samples of linen damask vestings.

Pencil sketch, intended for a design for a table-cloth. The border consists of ryeum leaves, wild foliage, flowers, and grasses, blended together; the middle a number of groups of flowers, so arranged as to give a brief history (in the language of flowers) of Her Majesty the Queen, H.R.H. Prince Albert, and the Great Industrial Exhibition; the centre a large group, representing the principal articles of commerce.

25 M'MURRAY, THOMAS, & Co., *Dromore, County Down, Ireland*—Manufacturers and Bleachers.

Bleached and unbleached linen.

26 KINNIS, W., *Dunfermline, Scotland*—Manufacturer.

Damask table-cloth, made of mill-spun flax yarn; the pattern is a combination of plants, flowers, and ornaments in both border and centre, with flower-sprigs round the centre. Damask table-cloth, pattern the grape vine. Another in the Watteau style.

Damask table-cloth, with centre, a vase of fruit and ornamental, from which arises a vase of flowers; and border, various plants and flower-sprigs. Others in Gothic and German styles.

Damask table-cloth made of yarns produced by Messrs. Marshall & Co., flax-spinners, Leeds, from China grass, being a new application of this material, with pattern same as that of the first article. Another, also of China grass yarns with running pattern.

27 BIRRELL, DAVID, *Dunfermline, Scotland*—Manufacturer.

Table-cloth design—a medallion bust of Her Majesty the Queen, surrounded with Gothic ornament, and the badges of the orders of the Garter, the Thistle, and St. Patrick—made of fine Flemish flax yarn; of new fabric and twill, containing 290 threads upon the inch of cloth.

Table cloth design—group of flowers and birds, with border, made of fine flax yarn.

Table-cover design—emblem and motto of the Church of Scotland, the burning bush, "Nec tamen consumebatur." Made with blue silk on fine flax yarn. All manufactured by the exhibitor.

28 HUNT, W., & SON, *Dunfermline, Scotland*—Manufacturers.

Double-damask linen table-cloth, manufactured for the service of the Queen. Design, deer stalking and Highland trophies, with a view of Balmoral Castle in the centre. Linen and silk wefted show-cloth, of the same design.

Double-damask linen table-cloth; design, union centre, with scroll border. Linen and silk wefted show-cloth of the same design.

Three double-damask linen table-cloths; designs, aconitum centre and garland; fruit centre and lily border; and hydrangea garland.

Four double-damask linen table-napkins; designs, Balmoral Castle, &c.; aconitum centre, &c.; fruit centre and lily border; hydrangea garland.

29 BEVERIDGE, E., *Dunfermline, Scotland*—Manufacturer. (Agent in London, W. MANVELL, 12 *Bow Churchyard*.)

Table cloths, bleached linen, brown and white linen, and extra satin, double and single damask, Gothic, arabesque, and other designs.

Dinner napkins and doyleys, bleached linen, and brown and white. Table cloths and dinner napkins, silk and linen. Tray tea napkins, bleached linen, single and double damask.

Nursery and towelling diapers, various qualities.

Stair carpeting and crumb or floor cloths, linen damask, and tapestry.

Table covers, coloured damask cotton, cotton and worsted mixed. Victoria covers, coloured cotton and wool damask. Table covers, merino (all wool), and coloured silk and wool, double damask. Table covers, three-coloured brocade, and coloured tapestry.

30 SADLER, S., *Ironmonger Lane, Cheapside*—Producer. Specimens of fine linen and cambric.

31 WILKS, J., 14 & 15 *Bread Street, Cheapside*—Producer. Specimens of linen.

32 ROGERS & WROE, 134 *Cheapside*—Producers.

Scotch embroidered handkerchief, sunk on French lawn.

34 DEVAS, M. T., MINCHENER, & ROUTLEDGE, 24 *Lawrence Lane*—Proprietors.

Group of damask table linen, exhibited for quality and cheapness.

35 DEWAR & SONS, *King's Arms Buildings, Wood Street*—Proprietors.

Silk and linen table cloth; in the centre, enclosed in the figure of a star, is Fame crowning Industry, the whole surrounded by a garland of flowers; in the corner of the border is the figure of Justice, encircled by a garland of flowers and ornamental scroll-work. In the centre of the border, within a garland of flowers, is the figure of Commerce, holding in one hand a palm branch (peace), and in the other two wreaths, to crown trade by land and sea, as exhibited on each side of the figure. The whole resting on a ground of ornamental scroll-work. Bleached linen table-cloth, the same pattern.

Silk and linen table-cloth, flower border, trees and stag in the centre; and side-cloth to correspond. Bleached linen table-cloth, same pattern. Silk and linen Communion napkin. Linen and silk and linen table-cloths.

Manufactured by William Kinnis, and designed by James Balfour, Dunfermline, Scotland.

36 CARTER BROTHERS; CANTER, JOSEPH; JACKSON & MATTHEWMAN; FLETCHER, HENRY T.; HATTERSLEY, PARKINSON, & Co.; PIGOTT & NEWTON; and HAXWORTH & CARNLEY, *Barnsley*—Manufacturers.

Bleached linen dowlases and pillow linen. Yarn and piece bleached sheetings. Grey and bleached pudding-

cloths. Bleached butter and tea-cloths. Grey and bleached kitchen rubbers. Plain and checked glass-cloths. Oyster cloths. Twilled dusters.

Yarn bleached and blue ducks. Bleached military and checked fancy ducks. Black ducks and drills. Natural coloured and fancy blouse hollandts. Grey roller, half-bleached and full-bleached towellings. Black and drab shanking cloth. Pudding canvasses. Horse bandages. Linen stripes and checks. Checked dusters and drills. Saddlers' checks. Purse canvas. White and grey cheese strainers. Screen cloths.

Loom and bleached medium huckabacks. Loom and bleached medical rubbers. Grey Baden Badens. "Electric" rubbers.

Tape and damask-bordered huckaback towels. Wimbourne towels. Table huckabacks.

Grey and bleached table diapers. Clouting, nursery, and towelling diapers. Grey and white, blue and white, and bleached pinafore diapers. Drabbetts.

Grey and white and bleached damasks. Damask dinner napkins, tray cloths, and aprons. Stair diaper and damask carpets. Twilled stair carpets. Damask and twilled crumb cloths.

Grey and "cream" bed ticks. Blue and white bed ticks. Blue and white mattress stripes. Blind and marquee ticks. Crankies.

37 TEE, CHARLES, & SON, *Barnsley*—Designers and Manufacturers.

Bleached, natural coloured, and fancy linen drills. Dyed plain linen and silk and linen vestings. Fancy vesting fabrics, mixed material. Plain and fancy fabric for dresses. Bleached toilet-cover fabric. Linen saddle rug. Printed linen and cotton yarns.

38 WALTON & Co., *Knaresborough*—Manufacturers.

Bleached linen sheeting, woven in hand-loom, and of considerable width and fineness. Linen-duck sheeting. Original Knaresborough linen. Brown linen tick. Heavy water-twist cotton sheeting. Blue linen check. Linen huckaback for towels. Medical rubbers.—All made by hand-loom.

39 HIBBERT, THOMAS, *Knaresborough*—Manufacturer.

Linen diaper table-cloth. Pieces of table-napkins and pocket-handkerchiefs.—All made by hand-loom.

40 EMSHALL, GEORGE, *Knaresborough*—Manufacturer.

Linen-duck sheeting. Linen shirt without seam.

41 LEEMING, JAMES, *Knaresborough*—Manufacturer.

Linen for shirting. Blue and white ticking. Linen chemise, woven without seam.—All made by hand-loom.

42 WILFORD, JOHN, & SONS, *Brompton, near Northallerton*—Manufacturers.

Piece of bleached sheeting, made from China grass; it possesses lustre, strength, and durability. Specimens of white linen drills for military trousers; combining closeness and smoothness of surface with durability.

New fabrics.—"Commodore," piece of white linen drill, for naval and boating trousers; and "Wellington," piece of white linen drill for military trousers. A range of patterns of various qualities of brown and white linen drills.

43 PEGLER, CHARLES, *Leeds*—Manufacturer.

Double damask table-cloth, in the brown state, with the arms of the Earl of Harewood; double damask table-cloth, arms of the Royal Horse Guards; napkins; bordered linen sheets.

Communion cloth, design the Last Supper, and other appropriate emblems; double damask table-cloth, equestrian statue of the Duke of Wellington.

44 HAYWARD, R., & SONS, *West Chincock, and 93 Minories, London*—Manufacturers.

Canvas for ships' sails, well known as "Coker canvas." Twines, used for sewing sails.

45 Row, J., *Crewekerne*—Manufacturer.

Sail-cloth; and towelling, called medical rubbers; manufactured from flax grown in the immediate neighbourhood.

46 POOLE, JAMES & CHARLES, *South Petherton*—Manufacturers.

Canvas for ship sails, made from foreign flax, and from English flax. Canvas for yacht sails, made from English flax. Seaming twine, made from English flax.

47 WITHEY & SMITH, *North Perrott, near Crewekerne, Somerset*—Manufacturers.

Fancy and other twines of various colours, made of flax, hemp, and cotton, used for crochet knitting, netting, carpet and silk weaving, and a variety of other purposes.

48 FINLAYSON, BOUSFIELD, & Co., *Glasgow and Johnstone*—Manufacturers.

Patent linen thread, common and satin finish, coloured both in black, dark blue, white-brown, and all fancy colours, in best and second quality, for tailoring purposes.

49 MORRISON & HURN, 25 *Norton Folgate*—Manufacturers.

Rope, line, and twine, of all sizes, and qualities, suited to every purpose.

Model marquee, flags, rick-cloth, horse clothing.

Suit of horse nets, sheep netting, hare and rabbit netting, portable bow net, drum net, casting net.

New portable fire escape.

Bed sacking, cocoa-fibre matting.

Snake, brush, double thrumb, and fancy bordered cocoa-fibre mats.

Corn, flour, and malt sacks.

Waterproof cloth for railway trucks, waggons, carts, drills, &c. All patented.

50 HOUGHTON, SARAH, *Ashford*—Manufacturer.

Superfine double damask table-cloths and napkins, Kent arms centre, and basket centre.

50A SCHWANN, FREDERICK, *Huddersfield and Leeds*—Proprietor.

Samples of Nos. 70, 80, and 100 leas line-yarn, A quality, made from French flax.

Samples of Nos. 25, 30, 40, and 50 leas line-yarn, D quality, from Dutch flax.

Samples of Nos. 18, 25, 35, 45, and 70 leas line-yarn, E quality, also from Dutch flax.

Samples of Nos. 10, 20, 30, 50, and 70 leas line-yarn, G quality, from Russian flax.

Samples of Nos. 20, 25, 40, 50, 60, 70, and 80 leas line-yarn, J quality, from Russian flax.

Samples of Nos. 30 and 35 leas line-yarn, K quality, from Russian flax.

Samples of Nos. 25, 30, and 45 leas line-flax, slack four-thread, second quality, from Russian flax.

Bunch containing samples of Nos. 20, 30, 40, and 50 leas line-yarn, slack twist, third quality, made from Russian flax.

Bunch containing samples of Nos. 18, 30, 50, and 70 tow, O quality, from French flax; and of Nos. 25 and 35, from Dutch flax.

51 TITLEY, TATHAM, & WALKER, *Leeds*—Manufacturers.

Patent linen sewing threads. Superior patent satin finish, or polished sewing threads.

Shoe threads, closing and stitching flaxes or lines.

52 GRIMSHAW & WILKINSON, 13 *Bridge End, Leeds*—Manufacturers.

Oiled cloths and sack covers.

53 HOLDSWORTH & Co., *Leeds*—Manufacturers.

Linen thread, patent soft satin-finish, and old finish; linen shoe thread, grey and finished.

54 HAWKE, E. H., *Scorrier, near Truro*—Manufacturer.

Flat ropes, for various purposes, manufactured from Polish or Russian hemp, and from white Manilla hemp, being lighter and stronger than Russian hemp rope. Shroud-laid rope, for maritime purposes, manufactured from Russian or Polish hemp. Rope, for reef-points in sails, &c., manufactured from Manilla hemp, and from China hemp. Round rope, for standing-rigging for ships, &c., manufactured from Russian hemp. Cable-laid ropes for warps, jacks, &c.

Patent coils of double and single wove tube fuzee, for conveying fire under water, blasting rocks, firing magazines, &c.; coils of safety-fuzee, being made solely of twine, and of an inferior quality.

55 DAY, JOHN, *Market Street, Oxford*—Manufacturer.
Church bell-ropes.56 YEATES, HENRY, *Abingdon*—Manufacturer and Designer.

Twilled, chequered, rush, and Manilla matting, for halls, offices, &c.; each piece varied. Cocoa-nut and Manilla matting; fancy cocoa-nut matting; superior jute carpeting.

57 LOCKHART, NINIAN, & SONS, *Kirkaldy, Scotland*
—Manufacturers.

Fine feather-bed tick, made entirely from flax and indigo-dyed. Feather-bed tick, of the same kind, but calendered.

Bleached diaper bed-room towels, made from the best flax yarns; fringed and plain.

Double huckaback, used principally for bath and rough bed-room towels; manufactured from double yarns.

Four, five, and six-bushel bags, generally used for holding flour, grain, potatoes, &c.; manufactured entirely from tow: the names of the owners are printed on them with oil paint, by a printing-press made for the purpose.

57A FALMOUTH LOCAL COMMITTEE—Producers.

Fishing-nets.

58 WEMYSS, ROBERT, *Kirkaldy, Scotland*—Manufacturer.

Piece of fine four-treadle bed-tick, made entirely of flax yarns. Taken from stock.

59 JEFFREY, ROBERT, *Mary Hill, Glasgow, Kirkaldy, Forfar, and Brechin*—Manufacturer.

Various samples of huck, dowlas, ticks, loom sheeting, diaper, huck and twill dusters, blue linen, &c.

60 JAMESON & Co., *Hull*—Importers and Manufacturers.

Hemp and flax from Russia, and jute from the East Indies, in the raw and undressed state as imported, and in several stages of manufacture. Yarn and canvas from the same, grey bleached, including ship's sailcloth, produced from flax and hemp in the "bolt," wool-sheeting or bagging, sacking, tarpauling, bed-sacking, railway waggon-covering, &c., of various qualities.

61 HALL, JOHN, & Co., *Hull, Yorkshire*—Manufacturers.

Samples of patent made cordage, from Baltic hemp, and of patent made cordage from Manilla hemp; tarred.

62 SPYVEE & COOPERS, *Hull*—Manufacturers.

Patent cordage for the use of sailing and steam vessels, mines and collieries, the whale fisheries, and deep-sea fisheries. Manufactured by steam and manual labour.

63 THE DUNDEE LOCAL COMMITTEE, *Scotland*—Producers.

Loom, or yarn bleached, 21 pieces of 25, 27, and 30 inch creguelas; 10 of 30 inch dowlas; 6 of 25 and 27 inch military duck; 2 of 27 inch coletas; 1 of 30 inch creas; 6 of 35 inch sheetings. 5 pieces of White Russia

sheeting, 40 inch; 2 pieces of cleared, or grass bleached 25 inch creguelas; 5 of 30 inch creas; 1 of 30 inch pramante. 21 pieces of brown, cream, and white 20 inch canvas padding:—manufactured by James Smeeton and Son, Dundee.

12 pieces of 27 inch bleached duck. 10 pieces of 40 inch cream Russia sheetings. 4 pieces of 40 inch striped and checked Russia sheetings:—manufactured by J. and A. Laing, Dundee.

Twelve pieces of light and heavy loom dowlas, 29 and 30 inch. 4 pieces of heavy loom sheeting, 36 and 90 inch. 16 pieces of 3-4th heavy loom and bleached huckaback. 10 pieces of bleached imperial ducks and military drills, 27 inch. 12 pieces of bleached dowlas, 30 and 36 inch. 5 pieces of bleached pillow linen, 40 inch. 5 pieces of 6-4ths, 10-4ths, 11-4ths and 12-4ths bleached sheetings. 3 pieces of bleached Russia diaper, 22 inch; 4 pieces of bird's eye diaper, 26 inch; 6 pieces of clouting diaper, 4-4ths; 13 pieces of dice and harness diaper, 8-4ths. 4 pieces of brown and bleached window linen, 42 inch:—manufactured by Alexander Lawson, King's Kettle.

Six pieces of common bleached canvas, Nos. 1 and 6. 6 pieces 24 inch tailor's padding canvas:—manufactured by John Mori, Dundee.

Five pieces of 40, 45, 54, and 60 inch Hessian, or packing canvas. 10 pieces 51, 54, and 60 inch striped bedding. 1 piece of 30 inch bed tick. 5 pieces of 24, 27, and 36 inch bed sacking. 1 piece of 24 inch padding canvas:—manufactured by Cox Brothers, Dundee.

Three pieces of 27 inch flour sacking. 4 pieces of 27 inch coal sacking. 4 pieces of 27 and 29 inch corn sacking. 1 piece of 26 inch striped jute sacking. 6 pieces of navy canvas, Nos. 1 and 6:—manufactured by Alexander Easson, Dundee.

Two pieces of 36 inch jute carpeting. 1 piece of 36 inch matting, made from Manilla fibre. 1 piece of 36 inch matting, made from coir and Manilla fibre:—manufactured by James Neish, Dundee.

Eight pieces of Osnabergs, manufactured by Don Brothers and Co., Dundee.

Ten pieces of 4-4th brown sheeting:—manufactured by W. and John Don and Co., Forfar.

Three pieces of heavy floor-cloth, 2 to 9 yards in width:—manufactured by Thomas Bell, Dundee.

Two pieces of 2-4ths jute stair carpeting. 4 pieces of jute stair carpeting. 1 piece of 30 inch tarpauling tow-warp, jute web. 1 piece of 27 inch jute bed sacking. 2 pieces of 42 inch cotton, or coffee bagging. 1 piece of 34 inch double hop pocketing:—manufactured by Alexander J. Warden, Dundee.

Four pieces of 31 inch strong bed tick. 2 pieces of 40 and 45 inch twilled sheeting:—manufactured by James Brown, Dundee.

Fifty pieces of striped and checked fancy linens, with a variety of patterns of each:—manufactured by John Leadbetter and Co., Dundee.

64 SOPER, RICHARD S., *4 Blossom Street, Norton Folgate*
—Manufacturer.

Specimens of lines, usually called patent lines, of various sizes, for hanging window-sashes, shutters, blinds, lamps, &c.

Specimens of skipping-ropes.

65 SMITH, J., *East Greenwich*—Manufacturer.

Specimens of ropes, lines, twines, &c., manufactured by machinery from Russia, Manilla, and Italian hemp; Irish, Baltic, and Egyptian flax and tow.

66 ULLATHORNES & LONGSTAFFS, *12 Gate Street, Lincoln's Inn Fields*—Manufacturers.

Shoemakers', saddlers', and harness-makers' threads. Heel balls for shoemakers' use.

67 MOORE, WILLIAM FINE, *Crinkbourne, Douglas, Isle of Man*—Manufacturer.

Canvas for ships' sails, manufactured from long Irish flax, woven by power, without starch or dressing. Twine-

canvas for the same purpose, and manufactured from the same material. Twine for sewing canvas for ships' sails.

68 HUDDART, Sir JOSEPH, & Co., *Limehouse*—Manufacturers.

Cordage and sailcloth.—Tarred cordage, from Baltic hemp. Untarred cordage—Manilla, Bombay, India Sunn, Italian, Hungarian, Columbia River, new. Power-loom-woven sailcloth, for the Indian navy, on the Dutch plan; for the British navy; and for the Merchant navy.

69 TULL, SAMUEL, 153 *Fenchurch Street*, and *Globe Fields, Mile End Road*—Manufacturer.

Specimens of twine, ropes, fishing lines, nets, &c., of different materials and qualities.

70 WALL, E. & T., *Banbury*—Manufacturers.

Hand-spun laid cords and twines, made from Polish Rhine hemp. Petersburg cut clean hemp. Polish Rhine and Petersburg hems, dressed and undressed. Twines made from Riga flax yarns and tow yarns. Whipcords made from flax yarns. Sash and jack lines, made from Indian spun hemp; clothes-lines from Manilla hemp; horse-hair and Manilla horse-hair clothes-lines. Horses' halters from Petersburg hemp. Bed sackings. Horse-hair cloth. Fancy door-mats, made from India jute hemp. Curled horse-hair.

71 HARFORD, GEORGE, *Gateshead*—Inventor.

Specimen of an improved sail-cloth, manufactured by Milvain and Harford.

72 GOUROCK ROPEWORK COMPANY, *Greenock*—Manufacturers. (SADLER, SAMUEL, *Ironmonger Lane, Cheapside*, Agent.)

Sail-cloth, extra best quality; bleached, second quality; boiled, third quality.

Tarred cordage, various inches; four stranded, hawser, and boltrope. Manilla cordage, various inches; wormed, hawser, and tarred.

73 EDWARDS, J.; EWENS, JOHN B., & Co.; GUNDRY, JOSEPH, & Co.; HOUNSELL, JOSEPH; HOUNSELL, WM., & Co.; PYMORE COMPANY; RENDALL & COOMBS; STEPHENS, J. P., & Co.; TUCKER, THOS., & Co.; WHETHAM, S., & Sons, *Local Committee, Bridport*.—Producers.

Specimens of the staple manufacture of Bridport, consisting of twines, canvas, webs, nets, lines, shoe-thread, tarpauling, sacks, &c.

CASE A.

Hemp and Flax in various stages of preparation.

CASE B.—Twines.

No. 1. Three-thread fishing long reel, 1 rand, 4½ lbs. per dozen rand.

2 to 4. Three-thread fishing short reel, 1 rand each, 6, 9, and 12 lbs. per dozen, made from Friesland flax.

5 to 7. Three-thread fishing short reel, 1 rand each, 6, 9, and 12 lbs. per dozen, made from water-rotted Dorset flax.

8 to 9. Three-thread fishing short reel, 1 rand each, 6, 9, and 12 lbs. per dozen, made from dew-rotted Dorset flax.

10 to 16. Three-thread fishing short reel, 1 rand each, 9, 12, 15, 18, 24, 30, and 36 lbs. per dozen.

17. Three-thread seal, No. 1, 1 skein.

18. Three-thread trawl, ½ rand, 48 lb. per dozen.

19. Three-thread salmon trawl, ½ rand, 72 lbs. per dozen.

20. Three-thread turtle, 1 skein, 72 lbs. per dozen.

21 to 25. Three-thread cod-net, 1 rand each, 4½, 9, 12, 15, and 18 lbs. per dozen.

26 to 32. Three-thread salmon-net, 1 rand each, 24, 30, 36, 40, 48, 60, and 80 lbs. per dozen.

33. Two-thread fishing short reel, 1 rand, 6 lbs. per dozen.

34 to 41. Two-thread porlick and mackerel, 1 rand each, 7, 9, 10, 11, 12, 14, 16, and 18 lbs. per dozen.

42 to 51. Two-thread cod-net, 1 rand each, 9, 10, 12, 15, 16, 18, 19, 20, 21, and 24 lbs. per dozen.

52. Nine-thread lobster-net, 1 rand, 84 lbs. per dozen.

53. Two-thread and three-thread shop. 54. Dutch.

55. Three-thread packing.

56. Fine three-thread bleached gilling.

CASE C.—Canvas.

1. No. 1. Bleached double warp, 24 inches wide.

2. No. 1. Bleached double warp, 18 inches wide.

3. No. 1. Half-bleached warp, 24 inches wide.

4. No. 1. Double warp, 24 inches wide, as used in Her Majesty's Navy.

5. No. 1. Single warp, full bleached.

6. No. 6. Double warp, full bleached.

CASE D.—Webs.

Nos. 1 and 2. Brown extra stout, machine web, 12 and 4 inches.

3. Striped extra stout, Artillery girth, 4 inches.

4. Brown gullet web, 1½ inches.

5. Superfine brown straining web, 3 inches.

6 and 7. Fancy linen girth web, 3¾ and 2 inches.

8. Striped tray web, 2¼ inches.

9. White boot web, 1½ inches.

10. White linen collar or bradoon web, 1¼ inches.

11. Diaper web, 2¼ inches.

12. Chair web, 1¾ inches.

13. Brown extra stout, Army girth, 5 inches.

14. Saddle-seat web, 8¾ inches.

15, 16, 17, 18, 19. Fancy linen girth web, 3½, 3¼, 2½, 2½ and 2½ inches.

20. White linen roller web, 4 inches.

21 and 22. Fancy linen roller web, 4 inches.

23, 24, 25, 26. Fancy linen roller web, 4 inches.

27. Fancy linen roller web, 5¼ inches.

28. White woollen brace web, 2¼ inches.

29. Fancy woollen girth web, 2½ inches.

30 and 31. Fancy woollen roller web, 5¼ inches.

CASE E.—Fishing-Nets.

1. Herring-drift, 18 feet deep, 11 fathoms long, 2¼ inch mesh, roped.

2. Mackerel-drift, 27 feet deep, 19 fathoms long, 3¼ inch mesh, roped.

3. Herring-drift used on English coast.

4. Mackerel-drift used on English coast.

CASE F.—Lines.

1. Deep sea, 1 coil.

2. Hand lead, 1 line,

3 to 6. Hambro', 1 line each, 9, 12, 15, and 18 strands.

7. Bank, 1 line.

8. Cod, 1 line.

9. North sea cod, 1 line.

10. Log, 1 line, 18 strands.

11 to 12. St. Peter's cod, 1 line each, 15 and 18 threads.

13. Long shore, 1 line.

14. Pallock, 1 line.

15. Squid, or jigger, 1 line.

16 to 18. Snoods, 1 line each.

18. Chalk, 1 line.

19. White sash cord, 1 line.

20. Brown sash cord, 1 line.

21 & 22. Whip-cord, various sizes.

23. Norsels, 1 lb., used for tying nets to head-ropes.

24. Two-thread marline, 1 slip.

25. Three-thread housing, 1 slip.

26. Mackerel, 1 line.

27. Long sed, 1 line.

CASE G.—Shoe-threads and Seaming-twines.

1. No. 1, common.

2. No. 2, common.

3. Best common.

4. Fine.

5. Fine flax.

6. Superfine flax.

7. Extra superfine flax.

8. Brown closing.

9 to 16. Varieties of half-bleached.

17 & 18. Green.

19 to 21. Yellow.

22. Yellow closing.

23. No. 8 fitting.

24. White closing.

These 24 articles are threads.

25 & 26. 6 and 9 three-thread seaming twine, from Dorset dew-ripe flax.

27 & 28. 6 and 9 three-thread seaming twine, from Dorset water-ripe flax.

CASE H.—*Fishing-nets.*

- | | |
|------------------------------|----------------------------|
| 1. Unbleached cast-net. | 4. Bleached herring-drift. |
| 2. Bleached cast-net. | |
| 3. Bleached sprat net-drift. | |

CASE I.—*Fishing-nets.*

- | | |
|------------------------|-------------------------|
| 1. Piece of Lance-net. | 6. Piece of mackerel. |
| 2. Piece of Capeling. | 7. Cod-seine, 3 inches. |
| 3. Piece of Dungarvon. | 8. Cod-seine, 4 inches. |
| 4. Piece of pilchard. | 9. Cod-seine, 5 inches. |
| 5. Piece of herring. | |

CASE K.—*Fishing-nets.*

1. A mackerel drift-net, as used in Sussex, fitted for sea.
2. A pilchard drift-net, as used in Cornwall, fitted for sea.

CASE L.—*Bags, Sacking, &c.*

1. Patent waterproof covering.
2. Five-bushel seamed bag.
3. Three-bushel round bag (without seam).
4. Four-bushel round bag (without seam).
5. Three-bushel seamed (heavy 6 lb.) bag.
6. Three-bushel round bag (without seam).
7. Five-feet bed-sacking.
8. Piece 4 feet 4 inches sacking-cloth.
9. Five-feet patent sacking.
10. Wool sheet.
11. Four-bushel round bag (without seam).

[These articles though little interesting in themselves, are yet important in a social point of view, and represent in some degree the interests of our country, as a maritime nation, which are connected with this manufacture.

Bridport may be considered the especial seat of the hemp and flax manufacture, a branch of industry which has flourished there for centuries; in fact, so early was that ancient borough celebrated for it, that in an Act of Parliament, 21 Hen. VIII., it was set forth, that the inhabitants "had, time out of mind, used to make within the town for the most part all the great cables, ropes, and other tacking for the Royal Navy, and the most part of other ships within this realm."

It is difficult to estimate the number of hands employed in the staple manufacture in the town and the surrounding district, the majority of the population being engaged in one or other of its branches; the number may be roughly estimated at from 7000 to 8000.]

- 74 HOLLOWAY, THOMAS JOHN, *Salisbury*—Manufacturer.
Hemp and flax twines.

- 74A BREMNER, JOHN, *Kirkcaldy, Scotland*—Manufacturer.

Pieces of sail-cloth, made entirely of Baltic flax yarn, the warp being of three-ply and the weft four-ply. Sail-cloth made upon this principle is stronger than canvas made in the usual way, particularly if the yarns are made from Irish flax.

- 75 DIXON & LONGSTAFF, *Stockton-on-Tees*—Manufacturers.
Sail-cloth, made from Baltic long flax; hand-loom woven.

- 76 HARRIS, JONATHAN, & SONS, *Cochermonth*—Manufacturers.
Dyed and bleached linen threads.

*** The fourteen following are placed on the North Wall, near the Flax Machinery in Class 5.

- 77 BEALE, BROWN T., *Andover Ford, Gloucestershire*—Manufacturer.

Sacking, tubing, tarpaulin of hemp and flax; flaxen great coats, &c.

- 78 PLUMMER, R., *Newcastle*—Manufacturer.
Specimens of canvas.

- 79 FRASER, D., *Arbroath, Scotland*—Manufacturer.
Navy bleached and boiled canvas. Improved brown canvas flax warps. Common brown tow, single brown tow, and common bleached canvas.

- 80 DUNCAN, D., & Co., *Arbroath, Scotland*—Manufacturers.
Hemp sail-cloth.

- 81 RENNY, SONS, & Co., *Arbroath, Scotland*—Manufacturers.
Navy sail-cloth made for British Government. Improved sail-cloth, made for the British merchant navy.

- 82 GORDON, G. & A., *Arbroath, Scotland*—Manufacturers.
Specimens of the various qualities of line and tow-yarn manufactured in Arbroath; dry-spun line-yarn, No. 1 to 50, and tow-yarn, No. 1 to 25. Sail-twine.

- 83 SALMOND, W., *Arbroath, Scotland*—Manufacturer.
Bleached unstarched sail-cloth; mill-washed long flax sail-cloth. Tarpaulin, unstarched, 28-inch brown. Single best tow vitrie. Best brown tow double canvas.

- 84 GARLAND, W., *Arbroath, Scotland*—Manufacturer.
Hop-pocketing. Floor-cloth. Nine-feet flax canvas.

- 85 RAMSAY & SMART, *Arbroath, Scotland*—Manufacturers.
Sacking. Brown canvas; brown single canvas.

- 86 ANDERSON, C., *Arbroath, Scotland*—Manufacturer.
Imperial and Russia ducks. Ticklenburgs. Russia sheetings, and padding canvas. Double canvas, single canvas, and waterproof cloth for railway covers. Hemp tarpaulings.

- 87 NICOL, A., & Co., *Arbroath, Scotland*—Manufacturers.
Towelling. Sheeting, bleached and brown. Osnaburg. Mixed-hemp sacking. Flour sacks. Rye-grass sacks. Coffee-bags. Shop-twine; hemp-twine.

- 88 CURR & Co., *Arbroath, Scotland*—Manufacturers.
Brown flax sheeting; brown tow sheeting. Loom dowlas; loom sheeting. Ticklenburgs. Ducks.

- 89 DAGNALL, CHARLES, & Co., *Little Chelsea*—Manufacturers.
Variety of mats and matting.
Samples of fine coir yarn from Cochin; of coarse coir yarn, Bombay; of coir yarn, Ceylon; of coir junk and fibre, from Cochin, Bombay, and Ceylon.
Specimens of silk grass, lute, or paut hemp, from Calcutta; and of Manila hemp.

[Coir yarn is obtained from the husk of the cocoa-nut, and "jute" from the stems of *Corchorus olitoricus*.—J. L.]

- 90 EDGINGTON, THOS. F., *45 Botolph Lane*—Manufacturer.
Specimen of composition cloth, made up from long flax, and dressed with a solution which renders it perfectly waterproof; used for railway luggage, truck covers, &c.

*** The five following are placed with Class 11.

- 91 SADLER, SAMUEL, *24 Ironmonger Lane*—Importer.
Bleached light linen, in cartoon boxes. Bleached sile-sias and platillas. Estopillas, bretanas, and creas legitimas. Thick linen handkerchiefs. All exhibited for style.

and cheapness, as well as adaptation for the South American, Mexican, and West Indian markets.

Bleached medium linens, extra strong linens, fronting linens, and extra strong shirtings. Exhibited for quality and fitness for the home trade.

92 COULSON, JAMES, & Co., *Lisburn, Ireland*—
Manufacturers.

Fine damask table-cloth, with the armorial bearings of His Grace the Duke of Bedford. The collar and stars of the Order of the Garter, &c., appropriately interwoven.

Fine damask table-cloth, made for His Grace the Duke of Sutherland.

Fine damask table-cloth, appropriately ornamented with the improved insertions, having the various royal insignia, with collars and stars of the different orders; made for Her Majesty.

Fine damask sideboard table-cloth, appropriately ornamented; made for Her Majesty.

Fine damask table-cloths, prepared for the Earl of Derby, and for the 1st regiment of Life Guards; the 2nd Life Guards; the 16th Lancers; the Scots Fusilier Guards; and the 57th Regiment, with badges, &c.

(Placed partly with Class 11, and partly with Class 14.)

[The antiquity and celebrity of the "fine linen" of Egypt, clearly points to that country, as the place where its manufacture originated. Specimens of this article wrapped about the Egyptian mummies, and supposed to be at least 3000 years old, are remarkable for fineness of texture. Linen was introduced into England, by the Flemings in 1253, as a substitute for the woollen shirting previously worn. Although Ireland now excels in this manufacture, it was not introduced into that country till 1634.

One kind of linen is still called Holland, from the place where it was first manufactured; this article having been largely imported for domestic use, before our home manufacture had arrived at such perfection as to take its place. Unbleached linen is called brown Holland, and is used for various articles of clothing and upholstery; silesia is a species of fine brown holland, glazed. Dowlas, is a strong kind of Irish linen, for shirting. Drill, is a stout twill for trousers. Damask, is a twilled fabric, similar to that made of silk, and much used for table-cloths; Dunfermline, in Scotland, and Ardoyne and Lisburn, in Ireland, are celebrated for the beauty and excellence of their manufactures in this article.

Brown damask is the same article unbleached, and being deemed stronger in this state, is used as more economical. Diapers are damasks of smaller size and simpler patterns. There are also union damasks and diapers, made of linen and cotton combined.

Sheeting linens are of various names and qualities, as Irish, Lancashire, and Scotch; also Russia, Yorkshire, and Barnsley; besides there are unions and imitations of these, of which the Russia is the strongest and coarsest. Huckaback, is a species of very coarse diaper used for towelling. Tick and union tick are well known articles for upholstery purposes. Canvas is usually made of hemp, but a finer sort is made from flax. Coarse canvas is used for sail cloth, tents, and coverings of various kinds. The finest article made in linen, is called cambric or Batiste, from Cambray, where it was first made, or Batiste, its first maker. French cambric is still much esteemed in the shape of handkerchiefs, though it is often equalled by our home manufacture. Scotch cambric is a cotton fabric, made in imitation of French cambric. Lawn is a species of very fine linen, approaching cambric in texture.—R. W.]

93 COULSON, WILLIAM, *Lisburn, Ireland*—Designer and
Manufacturer.

Fine damask table-cloths and napkins.

(Placed partly with Class 11, and partly with Class 14.)

95 CAPPER, JOHN, & SON, 69 *Gracechurch Street*—
Part Inventors and Makers.

Table cover, of linen damask, unbleached. The same, bleached, for use; manufactured in Scotland.

Registered striped or banded towelling. Invented by the exhibitors.

Newark huckaback towelling: the "Wellington," of yarn twice twisted in the weft, preserving its sharpness during wear; the "Russia," and the "Newark," with recent improvements in fabric.

Huckaback towellings, bleached, of various qualities, manufactured in England.

Sheetings for household use; manufactured in Ireland.

96 M'LEOWNAN, JOHN, & Co., 3 *Barge Yard*,
Bucklersbury—Manufacturers.

Bleached sail canvas, made from Irish flax, and by hand-loom.

For Class 15—MIXED FABRICS, INCLUDING SHAWLS—See Classes 12 & 15, page 185.



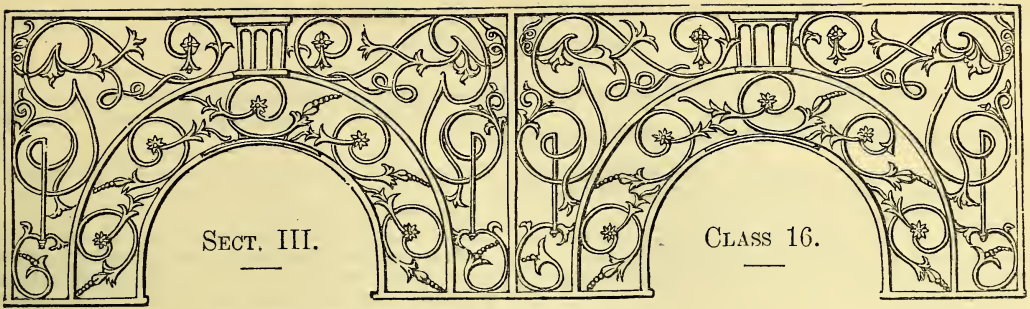

LEATHER, SADDLERY AND HARNESS, SKINS, FUR, AND HAIR.

INTRODUCTION.

THE present Class includes a variety of manufacturing processes relating to the commercial preparation of animal substances in the form of leather, skins, fur, hair, and feathers. Until within a recent period, experience rather than science has directed the labours of manufacturers in their operations upon these substances. And at present the rules taught by experience are in many cases still pursued in practice, with, however, such modifications as an intelligent comprehension of the operation of the chemical and other philosophical laws put into force in the processes would suggest.

The following Sub-Classes are recognised in this Class:—A. Leather, as rough and tanned, curried, enamelled, dyed—Oil Leather, as Buckskin, Doeskin, &c.—White and Alum Leather; Sheep and Skin Rugs, Parchment, and Vellum; B. Saddlery and Harness; C. Miscellaneous; D. Skins and Furs of all descriptions for personal and domestic use; E. Feathers, as those of the Ostrich, Marabout, &c.; F. Hair, ornamentally and usefully applied.

The position occupied in the Building is at the North side of the Western Main Avenue. The Areas included are G. H. I. and J., from 10 to 14. In addition, specimens are suspended from the Galleries, and in the centre of the Avenue is a case containing examples of the most rare and costly furs.

The localities in which the manufactures concerned in this Class are carried on, and from whence articles for exhibition have chiefly been derived, are Bermondsey, where the preparation of leather has been successfully conducted during a very long period, Hull, Swansea, Bristol, Cork, Liverpool, Edinburgh, and Falmouth.

The manufacture of leather has been estimated as only fourth in importance among the national manufactures of Great Britain. A large amount of capital is employed in its production, and the number of artisans and others directly supported by this branch of industry has been taken to amount to nearly a quarter of a million. The total annual value of the leather manufactures is computed at about fourteen millions sterling. It appears probable that in the mere article of boots and shoes, upwards of seven millions sterling are annually expended by the inhabitants of this country. If it be considered that rather more than half the leather produced is thus applied, the remainder is employed in the production of harness, saddlery, gloves, and the multifarious purposes for which leather is applicable. Of late chemistry has been studied attentively by those dependent upon this branch of industry, and successful results have ensued. A variety of patent processes exist by which the enormous amount of time involved in tanning on the old system is abridged to a surprising extent. With some specimens of leather it has not been unusual to devote eighteen months or upwards to their combination with the native principles of the bark. A few weeks are sufficient, under several of the new systems, to effect the same object. But it is stated that the leather produced rapidly, differs from that produced by a slower process of combination in its durability and solidity. And it is considered by some that time is an essential element in the manufacture, and that it cannot be advantageously shortened to any considerable extent. Leather is unquestionably a chemical compound, and this renders it probable that a slow and gradual process of combination between the gelatine of the skin, and the tannin acid of the bark, may produce a leather, to some extent, of different properties to that formed by a quicker operation. A very large amount of leather is, however, manufactured by the rapid process, from which it may be concluded that the product possesses great commercial value. A great variety of leathers in all conditions and states of manufacture is exhibited, with instructive series illustrating the peculiarities of different methods of manufacture, according to the difference of the purposes for which the prepared skin is to be afterwards applied.

An extensive and interesting collection of furs is exhibited. Probably the opportunity has never before presented itself for a complete study of this class of manufacture. Furs of the most rare description, devoted only to the use of monarchs, are among these specimens. To the naturalist desirous of ascertaining the genera and species yielding the furs of commerce, a subject on which much conflicting opinion exists, these objects, which are fully and correctly described in the Catalogue of this class, will be highly interesting and instructive. Feathers and hair are also represented by various interesting objects, possessing their peculiar merits and attraction. The number of exhibitors in this class is considerable; but since it includes boots and shoes, and other articles of personal and domestic use, in addition to saddlery, &c., the number of persons actually appearing in the capacity of manufacturers is to be distinguished from the proprietors. And as is the common rule, the class of producers or manufacturers bears only a small proportion to that of proprietors, or, in the commercial sense, vendors of manufactured articles.—R. E.

- 1 BEVINGTONS & SONS, *Neckinger Mill, Bermondsey*—Manufacturers.
Goat, sheep, seal, kid, and lamb skins, in the manufactured state.
Goat, seal, sheep, and calf skins manufactured into morocco, roans, skivers, and enamelled leather, for furniture, bookbinding, and shoe leather.
Kid, lamb, Cape sheep, and calf skins (alum leather), manufactured for gloves, shoes, and shoe binding.
Specimens of leather, with varieties in tanning and leather-dressing.
[Leather, such as that used for boots and shoes, is strictly a chemical product. The skins of a variety of animals are employed in the preparation of this article of universal use. The preparation of most varieties of leather consists essentially in the formation of a chemical compound, of the gelatine of the skin, and of a chemical principle called tannin, contained in the liquid used. Alum leather differs from ordinary leather in its properties and composition.—R. E.]
- 2 SQUIRE, THOMAS, *Letchford, Warrington*—Manufacturer.
Specimens of sole leather, tanned in Cheshire, made from hides, the produce of Buenos Ayres in South America, tanned with oak bark, the produce of Belgium, and a very small proportion of valonia, from Smyrna—26 weeks in process.
Sole leather, tanned without bark, made from hides, the produce of the United Kingdom; tanned with equal proportions of divi divi from South America, gambier from the East Indies, and valonia from Smyrna—16 weeks in process.
- 3 LUPTON, JOHN, *Chapel Lane, Bradford*—Manufacturer.
Specimens of cemented leather strapping, used for driving-belts in weaving and spinning.
- 4 BUSE, NICHOLAS, *Oxford Street, Swansea*—Manufacturer.
Improved calf-skins for the upper-leather of boots. Manufactured by a new process.
- 5 NICHOLLS, H., 5 *Stafford Street, Bond Street*, and 4 and 5 *Birchin Lane, City*—Inventor and Manufacturer.
Waterproof tanned leather, skins (of English and Cape sheep), for sporting articles, shooting gaiters, trousers, &c.
Black buckskin leather of permanent dye, suitable for trousers and other articles of dress.
Specimens of paste for cleaning white leather trousers, &c.
White buckskin hunting breeches.
Cleaning balls of various colours.
Improved composition for rendering the soles of boots and shoes waterproof and durable, and the upper leathers soft.
A new waistcoat in leather and cloth.
- 6 HARTLEY, ELIZABETH, *Low Bridge, Knaresborough*—Designer, Inventor, and Manufacturer.
Hearth-rug. Boa and muff. Carriage-bonnet and rug. Pair of cuffs.—All made from English lamb and sheepskin.
- 7 ROBINSON, J., *Waterside, Knaresborough*—Manufacturer.
Carriage-rugs of different colours. Hearth-rug. Boas and muffs. Carriage and wool-slippers. Table-mat.—All made from English and foreign sheepskin.
- 8 HILL, G., *Knaresborough*—Manufacturer.
Rugs for carriages, carriage-slippers, and tea-urn mats.
- 9 CLAPHAM, JOHN, *Knaresborough*—Manufacturer.
Hearth-rug. Rugs in sundry colours, for door-mats and carriages. Foot-muffs, for carriage use. Travelling shoes and boots, and slippers for domestic use. Muff. Boa. Victorine. Tea-urn mat.—All made from sheepskin.
- 10 DEED, J. S., *Little Newport Street, Leicester Square*—Manufacturer.
Specimens of leather.
Dyed sheep and lamb-skin wool rugs, or mats.
Wool rug, made from sheep and lamb-skins, representing the globe, Britannia, peace, and plenty, lion and lamb, and doves with olive branches. Motto—"The earth is the Lord's and the fulness thereof."
- 11 WILSON, WALKER, & Co., *Leeds*—Manufacturers.
Coloured sheep-leather skivers, for bookbinders, hatters, &c., coloured roans, for furniture and boots; roller leather, for silk and cotton spinning; chamois or wash leather.
Coloured calf and morocco, hard-grained, for bookbinding.
- 12 BENSON, C., 11 *Waterloo Street, Leeds*—Manufacturer.
Hair-bag for extracting oil from linseed, &c.
- 13 HOGARTY BROTHERS, *Cork, Ireland*—Manufacturers.
Boot fronts and legs, kip butts, roans, shoe midlings; black-grained calf for buttoned boots; calf-skins, waxed and russet, and tanned in sumac.
- 14 WINSOR, GEORGE, & SON, *Great Russell Street, Bermondsey*—Manufacturers.
Coloured wool rugs. Rugs, fancy and bordered. Hearth-rugs, fancy bordered, and white. Skins for cavalry, white and black. Skins japanned for socks. Skins for ladies' boas. French dog and lamb skins, for lining gloves, shoes, &c.; and carriage and foot muffs.
- 15 RHEAM, E., *Hull*—Manufacturer.
Specimens of boot and shoe leathers, of French and English calf-skin. Horse-hide from Spanish America, tanned and curried in England.
- 16 HOLMES, THOMAS, *Anlaby Road, Hull*—Importer and Manufacturer.
Specimens of tanned hide from the neck and back of a full-grown walrus, or sea-horse; also, from a young one, and from a cub.
Polishing-wheels covered with the same.
Heads of male and female walrus or sea-horse, taken by Captain Gravid at the Davis' Straits fisheries, 1850.
- 17 STOCKIL, WILLIAM, 33 *Long Lane, Southwark*—Manufacturer.
Wellington boot fronts and grafts, waterproof.
- 18 EVANS, THOMAS, & SON, 10 *Silver Street, Wood Street*.
Parchment and chamois leather.
Fancy parchment direction labels.
- 19 GLOVER, J. & T., 7 *Wood Street, Cheapside*—Inventors and Manufacturers.
Specimens of oil leather, from buck, doe, calf, sheep, and lamb skins prepared on an improved principle.
Specimens of gloves manufactured from leather prepared by the new process; and from Irish kid skins.
Improved button for gloves, shirts, wearing apparel, &c., which can be permanently attached without perforation. Improved opening for gloves.
[Leather dressed with oil, instead of by the process in which tanning combines with the gelatine of the skin, differs in many of its properties from leather prepared by tanning. Oil is generally made to penetrate the skins by "fulling" them after sprinkling the surface with oil. The oil enters into a permanent combination with the

skin, and the leather becomes soft and pliant. Ordinary wash-leather is an illustration of this mode of preparing skins for use.—R. E.]

20 HEMSWORTH & LINLEY, 30 *West Smithfield*—
Manufacturers.

Boot fronts and half fronts, from English calf skins; and from foreign calf skins, tanned abroad, but curried and blocked in England.

Cordovan hides, from South American horse hides.

[The enormous herds of horses congregated at times on the plains of South America have been noticed in striking terms by Baron Humboldt. During the inundations of which these plains are periodically subject, vast numbers of horses perish—the victims of the crocodiles or the waters. They are also the prey of the Indian hunters, and their hides form an important part of the export trade of several South American ports. These hides are in high repute in Great Britain; and in 1841, the quantity imported amounted to 394,526 cwt.—R. E.]

21 BRINDLEY, T., *Paradise Street, Finsbury*—
Leather reticules, dressing case, &c.

22 TOMLIN, WILLIAM, *Canal Bridge, Old Kent Road*—
Inventor and Manufacturer.

Superior description of parchment, nearly resembling drawing vellum.

23 BYAM, ELIZA, *Bazaar, Soho Square*.

Compound stationery case, in highly ornamented morocco. Novel in its form, being a model of a part of the Great Exhibition building.

A portable case, containing conveniences for travelling, in writing, working, dressing, and refreshment cases; it can be affixed to the inside of a carriage, and form an *escritoire*.

Lady's carriage companion. Another adapted for visiting and railroad travelling.

24 LEVER, J. & J., 13 *Sise Lane*—Manufacturers.

Writing, drawing, and binding vellum. Drum and tambourine heads. Writing and binding parchment.

25 WOOD, WILLIAM & SAMUEL, 32 *Bow Street*—
Manufacturers.

Calf skin in its natural state, with the hair on, simply dried; the same tanned in oak bark, prepared for the currier; the same of various thicknesses, curried for boots and shoes; and the same variously dressed as morocco, &c.; also for boots and shoes.

27 LENNY, JAMES THOMAS, 12 *Market Street, Manchester*—
Inventor and Manufacturer.

Portmanteau for travelling, with improved frame, without straps or buckles on the outside.

28 IMISON, CHARLES, 11 *Smithson St., York St., Hulme, near Manchester*—Designer and Manufacturer.

Improved portmanteau, constructed so that all the divisions are thrown open at one time, to facilitate packing, and the removal of any article without having to unpack, and to prevent rain or water getting in the inside, by making the staff to shut close all round.

29 FINNAGAN, J., *Manchester*—Manufacturer.

Travelling trunk.

30 JONES, WILLIAM D., *High Street, Shrewsbury*—Designer and Manufacturer.

Improved patent shot-belt—(the "Royal Albert")—ornamented in relief, by hand labour.
Specimens of other articles, manufactured in leather, &c.

31 SMITH, WILLIAM HENRY, & SON, 136 *Strand*—
Manufacturers.

Despatch boxes of various sizes and descriptions.
Travelling and dressing cases.
Writing, blotting, and card cases, &c.

32 GEORGE, CLEMENT, 102 *Dean Street, Soho*—Importer and Manufacturer.

Morocco and Russia leather, prepared for the use of upholsterers, coachmakers, bookbinders; also for dressing and other fancy case makers, boot and shoe makers, &c.

33 LAST, JOSEPH, 38 *Haymarket*—Inventor and
Manufacturer.

Registered wardrobe portmanteau, with five compartments.

Knapsack for pedestrians, containing an extra pocket on the top.

Improved bag for clothes, linen, boots, &c.

34 EAST & SON, 214 *Bermondsey Street, Southwark*—
Inventors and Manufacturers.

Patent velvet-napped, embossed, coloured leather. Embossed by Messrs. Customs and Co., 51 Bunhill Row, London.

35 ALLIN, WILLIAM, 126 *Drummond Street, Euston Square*—
Inventor.

Pair of bellows, the sides being made of wood instead of leather.

36 ALLEN, JOHN MICHAEL, 37 *Wardour Street, Soho*—
Manufacturer.

Homœopathic medicine cases. Tooth-powder box, to prevent the escape of the powder.

37 MOTTE, AUGUSTUS, 16 *Southwark Bridge Road*—
Inventor and Manufacturer.

Patent waterproof leather portmanteau, cut and made in one piece, and without a stitch.

38 LAST, SAMUEL, 256 *Oxford Street*—Inventor and
Manufacturer.

Registered railway portmanteau, for the use of travellers; divided into four compartments.

39 EVERETT & Co., 51 *Fetter Lane*—Manufacturers.

Blacking. Varnish for dress boots. Waterproof varnish for boots, harness, &c.

40 JAMES, J., 102 *Oxford Street*—Manufacturer.

Registered railway trunk, which contains a collapsible hat or bonnet case, a leather pocket, sliding division, and tray. Patent wardrobe portfolio.

41 JUDGE, CHARLES, 6 *Sion Place, East Street, Walworth*—
Designer and Manufacturer.

Leather buttons, each consisting of one piece of leather, for boots, shoes, gaiters, coats, and clothing in general.

42 WOODMAN, WILLIAM, 13 *Three Colt Court, Worship St., Finsbury*—Manufacturer.

Leather backgammon table.

43 HARROWS, G., 38 *Old Bond Street*—Manufacturer.

Ladies' improved waterproof travelling chest.

46 MAIBEN, CHARLES, *North Cottage, Vicar's Hill, Lewisham*—Inventor.

Saddle on an improved principle of fixing and relieving the flaps and pannel by hand. It is convenient for travelling, or for shifting after a heavy saturation: the bearings are free, and the use of nails has been avoided. A favourite-seated saddle can be supplied with additional flaps and panel.

- 47 READ, JAMES BIRD, *Peuryrn, Cornwall*—Manufacturer.
A shaved hide, for making best bridle reins; tanned, not curried.
A rough tanned cow-hide, the produce of Cornwall, for making saddle-skirts and stirrup-leathers.
Specimen to show the quality and kind of leather used in Cornwall, for the purpose of gearing the buckets of pumping engines with from 60 to 90-inch cylinders.
- 48 CLARK, CYRUS & JAMES, *Street, near Glastonbury, Somersetshire*—Inventors and Manufacturers.
Model of the rural factory, a portion of it containing a variety of shoes, &c.
Urn-rugs, flower-stands, muffs, cuffs, and victorines, made from English lamb-skin.
Caps made from British slinks, or mort lambs.
Varieties of socks for shoes, of cork and gutta percha covered with lamb-skin.
Ladies' carriage boot, of lamb-skin inside and out.
Gentlemen's brown wool-lined slippers. Ladies' slippers, of lamb-skin inside and out.
Foot muff, with hot-water case under.
Patent elongating gutta percha goloshes, with improvements; put on or off without touching with the hand; light, elastic and firm.
Registered shoes, which answer the purpose of boots, without fastening; elastic, and easy in walking.
Sample of leather gaiters, and housemaids' and men's gloves.
Angola goat-skin, English sheep and lamb-skin, and slink lamb or mort, in the raw state.
Angola hearth-rug, dyed in one piece: the pattern containing eight colours without joining; exhibited for the ingenuity of the pattern.
Pure white Angola hearth-rug.
Hearth-rug, with centre pattern, of lamb-skin.
Crimson Angola skin, exhibited for its size and depth of colour. Golden crimson stair and door-rugs.
Orange and pink Angola carriage rugs.
Yellow, blue, green, lavender, fawn and brown Angola toilet rug.
Crimson sheep-skin, exhibited for its size, and deep colour.
Brown door, gig, and carriage-rugs.
Varieties of carriage or window-rugs, with ornamented centre. Bedroom rugs, of various patterns.
Tanned mop, or mop-head.
- 49 ROOD, G., & Co., *Boltons-borough, near Glastonbury, Somerset*—Designers and Manufacturers.
Hearth, carriage, and toilet rugs, with designs; manufactured from sheep-skin and Angola goat.
White, crimson, and pink Angola rugs, for carriages, doors, recesses, &c.
White, brown, crimson, green, and blue sheep-rugs, for the same purposes. Carriage foot-muff.
Sheep and Angola goat-skins, in the raw state.
- 50 COOPER, MATTHEW, 25 *Swingate, York*—Designer, Inventor, and Manufacturer.
Improved side saddle, with pilch of Berlin wool work (from the establishment of Mr. Jancowski, York).
Military saddle, with pilch also of Berlin wool work.
Improved light hunting and racing saddle.
Somerset saddle, with skirt similar to a regular hunting saddle.
- 51 SOUTHEY, GEORGE WILLIAM, & Co., 16 *Little Queen St., Lincoln's Inn Fields*—Manufacturers.
Seal-skins and hides for the use of coachmakers, harness-makers, and accoutrement-makers.
Calf-skins for the use of accoutrement-makers and boot-makers.
Hog-skins and hides for the use of saddlers.
Hides for straps for machinery and pipe-hose.
Hippopotamus hides for the use of mechanical engineers.

- 52 MAXWELL & Co., 161 *Piccadilly*—Manufacturers.
Glass case, containing socket spurs (military regulation and others), and spring spur-sockets, with specimens showing their several stages of manufacture.
- 53 LUTWYCHE & GEORGE, *Skinner Street, Snow Hill*—Manufacturers.
Goat-skins, manufactured in England, for the use of bookbinders, shoemakers, upholders, coachmakers, &c.
English sheep-skins.
- 54 MARLOW, JAMES, *Walsall*—Manufacturer.
Steel carriage and riding bits; with new designs of ornamental character.
Spenser's patent metallic saddles.
Harness, with registered ornamental mountings.
Stair balustrade in malleable cast iron, possessing the strength of wrought iron.
- 55 COX, SAMUEL, *Walsall*—Inventor and Manufacturer.
Newly invented Albert stirrup and stirrup leather, and improved draw-mouth clipper-bit. The stirrup is always in a position to meet the foot, and can be put on or taken off, without the use of the buckle.
Registered draw-mouth, clipper-bit which may be used either with or without curb. Provisionally registered.
- 56 BANTON, EDWARD, *Walsall*—Inventor.
Patent enamelled waterproof horse harness, requiring no blacking.
Patent Hackney riding-bit, with moveable mouth.
Hackney bridle, round head and reins.
Hunting breast-plate. Hunting-bits, mounted with heads and reins.
- 57 HAWKINS, JOHN, *Stafford Street, Walsall*—Manufacturer, Inventor, &c.
Registered carriage and hackney bits, upon an improved principle.
Registered Chifney bit, used for either riding or driving, with "double mouth."
Steel stirrup-irons upon an improved principle, and ladies' slippers.
- 58 BRACE, HENRY, *Walsall*—Manufacturer.
Bits, stirrups, and spurs, for the South American markets.
- 59 PIM, JAMES E., *Mount Mellick, Queen's County, Ireland*—Manufacturer.
Snaffles. Snake's-head bit. Plain riding bit. Pelham stirrup irons.
- 60 HUDSON, SAMUEL, *Dublin*—Inventor, Designer, and Manufacturer.
A side-saddle with projecting "burrs" in the forepart of the tree, to prevent the saddle from shifting to the near side and galling the horse, or slipping forward; it allows the front part of the saddle to be an inch lower than usual, enabling the rider to sit in a horizontal position. The safe, flap, and skirt are all in one piece, and covered with hog-skin. The design of the ornamental work on the heads and safe—the rose, shamrock, and thistle. The stirrup is a recent improvement made by the exhibitor; it opens with a spring, and disengages the rider's foot in case of a fall.
Hunting saddle with elastic seat, on a new principle: invented by the exhibitor. The webs are attached to a strong arch of round steel near the pommel, and so constructed as to bear violent usage without injury, giving additional strength to the tree; the action of the spring is not more than one-eighth of an inch, which is found to be sufficient to produce the requisite degree of elasticity.
Plain hunting saddle—exhibited for general fitting.
Light form saddle with steel-plated tree.

- 61 **LENNAN, WILLIAM**, 29 *Dawson Street, Dublin*—
Manufacturer.
Set of full-chased, silver-mounted, and brass-mounted carriage harness; set of silver-mounted gig or cab harness. Quilted lady's side-saddle, with fans and leaping-head. Full shaft to gentlemen's hunting and steeple-chase saddles.
Double and single saddles for children.
- 62 **KANE, G.**, 69 *Dame Street, Dublin*—Manufacturer.
Portmanteaus and camp furniture.
- 63 **LAMBERT & SON**, *Bermondsey New Road*—
Manufacturers.
Wellington boot-fronts and half boot-fronts; grain and waxed calf-skins; cordovan hides and jockey legs.
- 64 **ASHFORD, W. & G.**, *Birmingham, and Houndsditch, London*—Designers and Manufacturers.
Specimens of whip manufacture and ornamental mountings.
Specimens of registered whip-sockets, or holders.
Specimens of saddlery, including a new design for a lady's bridle and bit.
- 65 **BROWN, T., & SON**, 7 *Moat Row, Birmingham*—
Manufacturers.
Specimens of cut back-head saddle-tree, with whalebone springs, galvanized plates, spring bars, and copper rivets, to prevent corroding; and various kinds of saddle-trees used in England, East Indies, &c., of improved constructions.
- 66 **PEEL, ARCHIBALD REED**, 151 *Strand*—Designer and
Manufacturer.
Improved Cleveland and East India hunting saddles; lady's saddle, with extra crutch.
The Victoria bridle and stirrup.
Set of brougham harness, with improved shaft and trace tugs.
- 67 **MIDDLEMORE, WILLIAM**, 31 *Holloway Head, Birmingham*—
Designer and Manufacturer.
Sets of gig harness of new designs.
New patent gentleman's saddle, with elastic seat.
Embroidered lady's saddle, with same improvement.
Fancy saddles and bridles.
A new mouthing rein for disciplining the mouths of unbroken horses.
Shot pouches, cigar cases, dram bottles, and sandwich cases.
- 68 **COLEMAN, THOMAS GEORGE**, *Lilley Hoo Farm, Offley, near Hitchin, Herts*—Inventor.
Improved patent general fitting saddle, expanding with the action of the horse's muscles, intended to take off dead pressure, and spread the weight.
Improved patent self-acting elastic spring roller, for horses.
Improved patent harness, with spring trace and tug, back-band and crupper. The spring trace assists the draught, taking off dead-pressure from the horses' shoulders.
Improved patent safety rein, to enable the driver to have complete control.
The general fitting saddle is constructed to expand with the action of the muscles, and spread the pressure or weight over a greater surface; also to protect the withers from being wrung—a fault frequently occasioned by the use of the common saddle. It is objected to the common saddle that in the event of a horse stumbling, the shoulders are forced up into the gullet of the pommel, and the saddle-tree is often broken; but even when this is not the case, the confinement of the shoulders invariably prevents their free action, and consequently the horse loses all chance of recovering itself.
The spring bar is intended to relieve the horse of much weight, and at the same time afford ease and comfort to
- the rider, as well as protection from the injuries that so often happen on the pommel and cantle of the saddle; these, in the new invention, being soft and elastic. The spring bar is applicable to side saddles.
The self-acting elastic roller obviates the injury resulting from the use of the present tight roller, which, not being elastic, when buckled round a young animal, essentially retards and injures the formation of the chest, while it confines and weakens the action of the lungs.
- 69 **GARNETT, WILLIAM**, *Tarporley, Cheshire*—Inventor
and Designer.
A saddle without seams, that is, having seat, skirt, and flap in one piece. Exhibited for lightness and cheapness. On the near side of the saddle is attached a patent spring bar, so constructed as to release the rider if thrown from his horse. On the off-side there is a swing bar, intended as an improvement upon the patent spring bar.
- 70 **VICK, RICHARD**, *Gloucester*—Inventor.
Improved registered harness hames—giving ease and facility of draught, by raising or lowering the shifting tugs as required.
- 71 **MUSSELWHITE, THOMAS**, *Devizes*—Inventor.
Patent elastic collar for horses, formed by the combination of iron, cork, horse-hair, &c.
Improved elastic collar for horses, to work without hames.
- 72 **WEIR, JOHN**, *Dumfries*—Inventor and Manufacturer.
A riding-saddle with elastic seat, the buckskin seat and flap covers being all of a piece.
Neck collar, designed to answer the double use of a separate collar and harness. The draught being fixed in the roll at the proper part, will prevent the neck of the horse being injured by the shifting of the harness.
Portmanteau containing hat-case, drawers, and pockets for papers, letters, &c., with separate places for articles of dress, umbrella, &c., all under one lock and key.
- 73 **MELLER, CHRISTIAN C.**, 15 *Riding House Lane, Langham Place*—Designer and Manufacturer.
An enamelled leather travelling-bag, with improved fittings inside, secret spring fastenings, and metal knobs to bottom to prevent wear.
- 74 **RAMSEY, W.**, *Hull*—Inventor and Manufacturer.
Registered elastic-seated saddle.
- 75 **CLARK, W.**, *Mill Hill, Leeds*—Designer and
Manufacturer.
A quilted summerset saddle; the work upon the seat representing St. George and the dragon; on the flaps, Britannia, surrounded with roses, thistles, and shamrocks; on the skirts, the Prince of Wales' feathers.
- 76 **THOMAS, CHARLES**, *Stratford-on-Avon*—Manufacturer.
Registered flexible saddle, with metal cantle, yielding to very slight pressure. It is so constructed as to promote the circulation of air between the seat of the saddle and the horse's back, contributing to the comfort of the rider, and preventing the galling of the horse.
- 77 **CAISTOR, A. B.**, 7 *Baker Street, Portman Square*—
Designer and Manufacturer.
Hussar saddle, with holsters and furniture.
Hunting saddle.
- 78 **BLACKWELL, S. & R.**, 259 *Oxford Street*—
Inventors and Manufacturers.
A cab or phaeton harness, with gilt mountings, chased with emblems of Great Britain and Ireland; the ornaments on saddle, bridle, &c., are the collar, star, and badge of the Order of the Garter. The whole made of black patent leather.
Improved fetlock leg, and speedy cut boots, to prevent

horses being lamed by cutting; made of elastic vulcanized India-rubber web and leather.

Eye-blinds, for singeing, bleeding, &c.
Patterns of improvements in saddlery.

79 PASSMORE, WILLIAM, 27 *Little Windmill Street, Golden Sq.*—Designer and Manufacturer.
Single-horse harness, with improved hames and furniture.

80 ATKINSON & ELDRID, 185 *Regent Street*—Manufacturers and Proprietors.
Hunting whips, of various patterns, with silver mountings. Ladies' and gentlemen's riding whips, with gold and silver mountings.

Gig, four-horse, and tandem driving whips, of various kinds.

Registered ladies' parasol driving and riding whips.
Walking sticks.
Gold and silver-mounted walking and riding canes.
Drinking bottles and flasks.
Hunting and tandem horns, dog whistles, and other sporting articles.

81 MARTIN, W. H., 64 *Burlington Arcade*—Inventor and Manufacturer.

Parasol riding and driving whips.
Ladies' and gentlemen's driving, riding, and hunting-whips.

Riding-cane, dress cane, and walking-stick, made from the rhinoceros horn.

Specimen of the Wanghee cane.
New combination—a walking-stick, whip-stick, or umbrella-stick, containing long cylindrical bottle and wine-glass, and receptacle for biscuits or compressed meat, intended for railway travellers and others. Invented by Francis Whishaw, Esq.

82 SHIPLEY, J. G., 181 *Regent Street*—Inventor.
Large full quilted saddle with improved stirrup leather. Provisionally registered.

83 SKINNER, AMBROSE, *Camberwell Green*—Inventor and Manufacturer.
Air-filled horse collar, intended to prevent wrung or galled shoulders, and jibbing.

84 HICKS, HENRY, 52 *Davies Street, Berkeley Square*—Inventor and Manufacturer.
Lady's saddle, exhibiting the application of an elastic support for the left leg of the rider. Provisionally registered.

85 GREEN, ROBERT, 8 *Edward's Street, Portman Square*—Manufacturer.
Ladies' saddle, constructed on an horizontal tree, on an improved principle. Bridles.
Somerset and hog-skin hunting saddles.
Set of single horse harness, and horse clothing.

86 WHITE, J. C., 29 *Liverpool St., City, and 185 Regent St.*—Inventor and Manufacturer.

Set of pair-horse carriage silver-mounted harness, with improved registered tugs. These tugs are intended to supersede the use of the large tug buckles, and are lighter in appearance. The improvement consists in their being straight tubes, into which the trace passes, and is secured by a bolt passing through, which can be taken up and down and the trace easily adjusted; the trace having a straight pull from the bolt, is not liable to meet with the unsightly curve or bend which causes it to crack and break.

Set of single, or brougham harness, silver mounted, with improved registered tugs. The improvement in the single harness is the shaft tugs, which secure the shafts and prevent the shaking or jolting of the vehicle, without the necessity of wrapping the belly-band round the shafts.

Set of light pony harness, silver mounted, with improvements.

Part of a set of tandem harness, with improved bars, silver mounted, with the registered parts attached.

87 BOWMAR, C. B., *Leicester*—Inventor and Manufacturer.

Ladies' and children's victorines, riding boas, and mantilla polkas, made of lambskin cured, with wool attached. Jenny Lind's mantilla and muff attached, imitation of squirrel. Ladies' and children's cuffs. Brighton round and curly boa. Round ruff; children's ruff. Muff.

Ladies' and men's fleecy patent leather socks.
Lapland wool rugs, coloured and white.
Children's frame-worked coats, edged with wool.

88 TISDALE, EDMUND, 34 *Broad Street, Golden Square*—Manufacturer.

Somerset hunting saddle-tree, in the first stage of manufacture; the same, with a set back-head, in a finished state, adapted for high-withered horses, &c.

Side saddle-tree, with a leaping head, for safety to the rider.

89 LANGDON, WILLIAM, jun., 9 *Duke St., Manchester Sq.*—Designer and Manufacturer.

Light phaeton harness, bearing the coronet and initial of H.R.H. Prince Albert, made throughout of patent leather, and stitched with white silk; with silver-plated buckles, &c.

90 BLYTHE, ROBERT, 4 *Park Lane*—Manufacturer.

Lady's saddle, with horizontal and elastic seat, new in style and design.

Hunting or park saddle, with improved elastic seat.
Harness pad, with end screws removed.

91 PENNY, J., 37 *Union Street, Middlesex Hospital*—Manufacturer.

Improved design for harness mounting.
State pony bridle for H.R.H. Albert Edward, Prince of Wales, designed by W. H. Rogers; the leather-work by W. Langdon, 9 Duke Street, Manchester-square.

Specimens of harness mountings.
Cabinet drawer handles, metal gilt.
Portrait of H.R.H. Prince Albert, embossed by hand from sheet silver.

Heraldic and ornamental skewers.
Proof from a new style of gutta percha mould, Landseer's favourites. "Tam O'Shanter," "The Wolf and the Lamb" (Mulready), and "The Blind Fiddler," embossed by hand, from sheet copper.

Similar pictures in metal chasing.

92 SWAINE & ADENEY, 185 *Piccadilly*—Manufacturers.

Racing whip, mounted in silver gilt. This whip is represented in the annexed cut. The design is emblematic of the Exhibition, and representative of the four quarters of the globe.

Riding whip, mounted with gold, set with brilliants and rubies.

Ladies' riding whips, with fan or sun-shade attached, of new construction; also with parasols.

Chowrie riding whips, with horse-hair plumes, especially adapted for India or other parts where insects trouble horse and rider.

Riding whips of various patterns and devices.

Driving whips. Canes of various kinds.

Registered universal whip-socket.

Hancock's patent flexible-back horse and other brushes.

Improved horse-cloth, allowing a free escape of the moist heat of the body, which is retained by a woollen blanket; and also preventing the breaking out into a cold sweat, common to horses after being ridden or driven hard.



Messrs. Swaine and Adeney's Racing Whip.

93 BELL, CHARLES, 34 Wigmore Street—Manufacturer.

Improved lady's saddle. A lady's saddle, with new designs, on an improved principle. A dress single harness, with designs for harness furniture.

94 BYWATER, WITHAM M., 99 Piccadilly—Designer and Manufacturer.

Single horse brougham harness, with patent silvered glass front, and rosettes.
Improved Russian cavalry and other bridles.

95 MORIARTY, DANIEL, 34 Berwick Street, Oxford Street—Manufacturer.

Phaeton harness, silver mountings.
Single-horse harness, lined throughout, silver plated on German silver. A single-horse harness, lined throughout, with brass-mountings, bits, and breeching, complete.

96 CUFF, R., 18 Cockspur Street—Designer and Manufacturer.

Embroidered velvet saddle, riding bridle, and harness, with gilt ornaments. Hunting and other saddles and bridles.

97 COLEGRAVE, F. E., Round Hill House, Brighton.

A saddle, made by Bartley, of Old Quebec Street. It is fitted with a patent saddle-girth spring.

98 WILSON, T., & SON, 18 & 19 Vere St., Oxford Street—Manufacturers.

New safety side-saddle, by which a release from the saddle is ensured in case of a fall.

99 RUTLAND, WILLIAM, 199 Sloane Street, Chelsea—Manufacturer.

Lady's saddle, of new design, with moveable leaping head, sometimes called third crutch.
Improved gentleman's spring-saddle.

100 PEARL, JAMES, Old Kent Road—Manufacturer.

Harness, with bridle-fronts, and rosettes of satin and painted ribbon, whalebone, patent leather, and velvet.
Painted canvas and patent leather for harness fronts.
Riding-bridle and harness bridle-fronts.

101 CANAVAN, AYMOND, 7 Wymdham St., Bryanstone Sq.—Proprietor.

Two saddles, made by Robert Gibson & Co., Coventry Street, one with the exhibitor's registered safety panel; the other with Reed's patent girth regulator.
Five brushes for cleaning all kinds of metals, made of elastic buff leather, manufactured by Mr. Kent, brush manufacturer, Marlborough Street.

102 CLARKSON, I. C.—Manufacturer.

Harness straps, &c., manufactured by machinery.

103 STOKER, JOSEPH, 49 Old Street, St. Luke's—Inventor and Manufacturer.

Lady's saddle, with revolving heads for riding on either side, with increased facility for dismounting, so as to prevent the dress becoming entangled in the heads; also adapted to horses of different sizes.

Improved pack-saddle for overland conveyance of luggage by horses or mules.

104 MACKIE & SON, Maidenhead, Berks, and Beaconsfield, Bucks—Inventors and Manufacturers.

Horse collar, for heavy draught, especially up hills with bad roads; applicable for artillery.
Set of improved pony harness.

106 HUGHES, ROBT., 52 Clifton Street, Finsbury Square—Manufacturer.

Heraldic mountings for harness in brass, plate, and solid brass gilt.

107 EARNSHAW, HENRY, 91 Wimpole St.—Manufacturer.

Blue Morocco bridle. Victoria bridle. Plain hunting bridle. Round and flat bridles. Hunting breastplate. Round pair-horse carriage reins. Registered dumb jockey, on an improved principle.

111 KIRKBY, W., Caistor, Lincolnshire—Inventor.

Ladies' side saddle of superior workmanship.

112 BOOTH, JOHN PETER, South Quay, or Union Quay, Cork, Ireland—Inventor and Manufacturer.

Victorine, boa, and muff, made of the Irish turkey side feather.

Victorine, made of the Irish turkey wing feathers; useful for trimming and ornamental articles of dress, &c.

114 HOOK, J., 66 New Bond Street—Manufacturer.

Ladies' riding boots. The Wellington, with rand forepart and turnover heel, and chased spurs of new design.
Patent elastic boots, with spurs and box.

Morocco boots, with high stitched heels.
Dress boots and shoes, in lace, silk stocking, and plain satin, black and white, crossed with ribbon.

Costume boots, blue safin Hungarian boots, with silver heels and trimmings. White and black satin and silk boots, high heels.

Walking boots and shoes, waterproof, with inside and outside clumped, and cork soles.

Costume shoes, the old English, Swiss, Greek, Turkish, and Italian, with heels, gold and silver trimmings.

Dressing slipper, plain and embroidered, with and without heels, welted and turnovers.

Dress goloshes, black and bronzed, silvered and gilt.
Walking clogs in leather and Indian-rubber, with improvements.

Specimens of children's boots, shoes, and goloshes.

Ladies' boot and shoe trees, joint stretched, &c.

- 115 BERRALL, W., & SON, 60 and 61 *Marylebone Lane*—Manufacturers.
Top boots for racing. Wellington boots. Ladies' boots. Children's boots for weak ankles.
Boot fronts from skins imported in a rough state.
Samples of bark tanned soles from English and foreign hides.
- 116 PARKER, W., & SONS, *Wood Street, Northampton*—Manufacturers.
Boots and shoes.
- 117 LLOYD, J. P., *Northampton*—Manufacturer.
Boots and shoes.
- 118 BEARN & JEFFS, *Parade, Northampton*—Manufacturers.
Boots and shoes.
[The boot and shoe trade of the county of Northampton employs not fewer than 30,000 persons. The raw material, after passing through several processes, is received by the boot and shoe manufacturers. The leather is then cut up into proper sizes, is given out to the workpeople to be blocked at their homes. After this is done the work is then closed, and afterwards made up. These operations are carried on principally at the homes of the workpeople. A very large number of children are employed in this department of trade.]
- 119 MOORE, G., *Northampton*—Manufacturer.
Boots and shoes.
- 120 LINE, WM. & JOHN, *Deventry, Northamptonshire*—Manufacturers and Proprietors.
Wellington, Clarence, cloth, leather leg, button, buckskin, dress, best stout calf, and other boots of different qualities. Calf walking, tie, and other shoes.
- 121 GROOM, J. & R., *Northampton*—Manufacturers.
Policemen's boots and shoes. Long and short waterproof boots; regulation army Blucher boots.
- 122 GRAHAM, J., 109 *Naylor St., Oldham Road, Manchester*.
Pair of clogs.
- 124 HUTCHINGS, JOHN, 20 *Green Street, Bath, Somerset*—Inventor & Manufacturer.
Ladies' kid-leather double sole boot, with noiseless rotary heel, and fastened with elastic shank buttons.
Ladies' elastic double sole boot, with noiseless military heel; ladies' single sole boot, and elastic half-dress shoe.
Gentlemen's dress boot, and elastic half-dress ankle boot, with noiseless military heel. Elastic walking boot, suitable for feet troubled with corns and bunions; and boot with noiseless rotary heel.
- 125 LOMAS & EVES, 155 *Moor Street, Birmingham*.
Improved boot-trees and stretchers.
- 127 RAMSBOTTOM, E., *Merton, Surrey*—Inventor.
Improved clog. The sole does not bend, but the inside of the clog is moulded to the shape of the foot.
- 128 ROBERTS, G., *Twistock, Devon*—Inventor.
Patent clog, having a fixed instep strap, and so constructed that, by means of a drop connected with a lever and spring, it can be put on and off without stooping or touching it with the hands.
- 130 THOMPSON, S., *Blackburn*—Manufacturer.
Clogs, as worn by the operatives of Lancashire and Yorkshire; the same improved by the introduction of steel-springs into the soles, so as to give elasticity to the tread.
- 131 ATLOFF, JEAN G., 69 *New Bond Street*—Inventor.
Boots, shoes, and clogs, with side spring.
Dress boots, with steel spring waist.
Military boots, &c.
- 132 WALLACE, T., *Brandling Place, Newcastle-upon-Tyne*—Inventor.
Improved boots for children having weak ankles and legs.
- 133 HENSON, W. G., *Kettering, Northamptonshire*.
Morocco boot, designed without blocking.
- 134 PETTITT, G., & SON, *Birmingham*—Designers and Manufacturers.
Specimens of waterproof goloshes, compounded of caoutchouc, leather, and gutta percha.
- 135 SAUNDERS, C., *Reading*—Manufacturer.
Red morocco leg patent goloshed vandyked button boot, with 40 stitches to the inch, beaded top, button holes, shell heel, 2½ inches high, on 12 pillars, silk lined, with satin top-piece stitched.
- 137 ATHENÆUM BOOT & SHOE WAREHOUSE, *Norwich*—Producer.
Boots and shoes.
- 139 MATHER, J., *Rochdale, Lancashire*—Maker.
Wellington boots, with steel-spring shanks, which improve the form, and retain the shape.
- 141 CREAK, JAMES, *Church Terrace, Wisbech*—Inventor and Manufacturer.
Improved waterproof button, buckle, and Blucher boots. Provisionally registered.
- 142 COWLING, JOHN, *Richmond, Yorkshire*—Inventor and Manufacturer.
Gentlemen's shooting boots, on a new principle: by the fastening at the side, the boots can be made tight or easy at any moment. Waterproof to the top, and without gussets.
- 145 DOE, WILLIAM, *Colchester*—Manufacturer.
Improved strong high shoes.
- 146 NEWMAN, GEORGE, 101 *Gloster Lane, Brighton*—Manufacturer.
Wellington boot, exhibited for construction and workmanship.
- 147 MCGIBBON, JOHN, 30 *North John Street, Liverpool*—Manufacturer.
Dress military boots, gold lace tongs and welts, with revolving heel.
- 148 BARRACLOUGH, SAMUEL, *Tamworth*—Inventor and Manufacturer.
Two pairs of dress boots, manufactured of materials to render them impervious to water.
- 149 ALLEN, CHARLES, & SON, *Treffgarne Rocks, Pembroke, Wales*—Manufacturers.
Gentleman's shooting boot, on an improved plan, warranted waterproof.
- 150 HEFFORD, JOHN N., *Derby*—Proprietor.
FACER, F. & W., *Northampton*—Manufacturers.
Dress Wellington boots, with emblems inserted on crown and cushion; Rose, Shamrock, and Thistle, &c., and ornamentally-finished top, 53 stitches in the inch.
Patent-leather top boots, with emblem worked in the tongue; crown, and cushion.
Black satin dress Wellington boots, with patent-leather toe, cap, and back-strap.
Satin dress boots, with elastic side springs.
Dress patent-leather pumps.
Dress shoes, without seam or stitch in either tops or bottoms.
- 151 HUDSON, A., *Cranbrook*—Manufacturer.
Pair of top-boots, with seamless legs and tops.

- 152 **WRIGHT, RICHARD**, *Richmond, Yorkshire*—
Manufacturer.
Patent boots and shoes, free from seam or roughness under the sole of the foot. The sole is not dependent on a welt, or narrow slip of leather, but is attached to the upper-leather.
- 153 **VINCENT, R.**, *Glastonbury*—Manufacturer.
Suit of leather clothes, to imitate superfine black cloth.
- 154 **CLARK, BENJAMIN**, *57 Louth Street, Whitehaven*—
Improver and Manufacturer.
Ladies' Cumberland boot clogs.
- 155 **BURGESS, GEO.**, *South Bridge, Edinburgh*—Designer
and Manufacturer.
Improved Balmoral shooting boots, impervious to water. Highland brogues. Specimens of the shoes worn with the full Highland costume in ball or drawing room.
- 156 **BAXTER, RICHARD**, *Thirsk, Yorkshire*—Inventor and
Manufacturer.
Pair of walking boots, with clogs and springs attached, for ease in walking.
Pair of skating boots, with spring attached to the wrist of the foot, and the skate-iron working with a pivot at the heel.
- 157 **PEPLOW, WILLIAM**, *Browning Street, Stafford*—
Manufacturer.
Ladies' white satin, ottoman silk, green shot, goloshed, elastic button gaiter (new design). Elastic gusset, having no front seam. Fawn-coloured lasting side lace and cashmere boots, &c.
Goloshed boots; in a new style.
Velvet carriage tie boots.
Satin, kid, velvet, and morocco morning slippers.
Silk elastic cloth and button shoes; of new design.
- 160 **DODGE, W.**, *Sherbourne, Dorset*—Manufacturer.
A pair of hunting boots.
- 162 **MEDWIN & Co.**, *86 Regent Street*—Manufacturer.
Registered elastic boots. Elastic side, dress, and other boots. Top-boots for racing, weight of each boot 2½ ounces, or under 5½ ounces the pair.
- 163 **HALL, J. SPARKES**, *308 Regent Street*—
Manufacturer.
Ancient, British, and Roman shoes and sandals. Anglo-Saxon shoes and boots of the 7th century. Norman half boots, of Robert (the Conqueror's eldest son). Decorated shoes of the 11th century. Richard Cœur de Lion's boots. Norman shoes, with long pointed toes and chains. Long pointed shoes, worn by Richard, constable of Chester, in the reign of Stephen. King John's boots, richly decorated with circles. Henry the Third's boots, copied from his tomb in Westminster Abbey. St. Swithin's shoes, rights and lefts. Elegant shoes of the time of Edward I. Shoes with blue, red, and white stockings. Shoe of the time of Richard II. Boot of the time of Edward III. Shoes of Henry VIII. and the Earl of Surrey, with wide toes. Boots of the time of Charles I. and II. Boots and high-quartered shoes, William and Mary. Shoes during the reigns of George I., II., and III. The Duchess of York's shoe, 5¼ inches long.
Elastic shoe soles, cut by machinery.
Elastic gaiters, &c.
Vulcanized India-rubber goloshes.
- 164 **HALL & Co.**, *Wellington Street, Strand*—
Patentees and Manufacturers.
Boots and shoes made of leather-cloth, or pannosorium. They are cleaned with ordinary blacking.
- 165 **LEWEN, RICHARD GEORGE**, *22 Portman Place, Edgware Road*—Inventor and Manufacturer.
Mechanical lasts, made from models taken from nature. A cast of the foot is taken in plaster, and from this the shape is reproduced in wood, by machinery.
- 166 **HARTLEY, JOSHUA**, *11 King Street, St. James's Square*—
Manufacturer.
Top-boots, of English leather; boot polish.
- 168 **GODFREY & HANCOCK**, *3 Conduit Street, Regent St.*—
Inventors and Manufacturers.
New ladies' house and walking boot.
Satin, kid, and prunella shoes.
Waterproof over-shoes and extensible goloshes, &c.
- 169 **CANT, G. W.**, *69 High Holborn*—Manufacturer.
Patent boot-tree for bootmakers' use.
- 170 **M'DOWALL, W.**, *11 Mills Buildings, Knightsbridge*.
Ankle-supporting boots for ladies and children with weak ankles, and is also applicable to gentlemen's boots. Provisionally registered.
- 171 **DESMOND, MICHAEL**—Manufacturer.
Pair of dress patent-leather gentleman's boots; square edge; forepart, 40 stitches to the inch; sole and welt thickness of a sixpence; channel waist; and inch and a half heel.
- 173 **GUNDRY, WILLIAM**, *1 Soho Square*—Manufacturer.
Ladies' and children's boots and shoes, including specimens in different colours, and shapes of the "soccopedes elasticus."
Boots made of elastic silk, but without the side gussets. Cork soled boots, made with Dowie's patent elastic waistpieces.
- 174 **MARSH, F.**, *148 Oxford Street*—Manufacturer.
Assortment of ladies' and children's boots and shoes.
- 176 **GOODEVE, GEORGE**, *16 John Street, Crutched Friars*—
Designer and Inventor.
A pair of top boots, for horse racing; weight, 3 ounces; made in four hours.
- 177 **GUPPY, JOHN WILLIAM**, *2 Prince's Court, Dorset Place, Pall Mall East*—Manufacturer.
Ladies' cloth button boots, stitched welts and patent leather, goloshed.
- 178 **WINTER, C.**, *Norwich*—Manufacturer.
Ladies' boots and shoes, with embellished soles.
- 179 **GILBERT & Co.**, *Old Bond Street*—Manufacturer.
Jockey, hunting, Holderness, shooting, and dress boots. Lady's riding boots. Elastic hunting boots, with elastic gores at the bend of the knee, fitting without wrinkles in any position of the leg, and equally adapted for walking or riding. Registered.
- 180 **DOWIE, JAMES**, *455 Strand*—Inventor,
Patentee, and Manufacturer.
Boots and shoes, in adult and smaller sizes. Military boots.
Model of a machine to relieve the boot and shoemaker from the usual constrained posture.
- 181 **TAYLOR & BOWLEY**, *53 Charing Cross, and 25 Spring Gardens*—Manufacturers.
Boots and shoes, made with the patent elastic waists, formed of India-rubber and prepared leather, admitting of the natural action of the feet, and giving ease to the wearer. Exhibited for durability and economy. The application of this principle is represented in the cut on the next page.

By this plan thick soles are freed from rigidity; and persons accustomed to wear thin soled shoes, may use with advantage the stouter kinds made on this principle. The soles are made with gutta percha, cork, or leather. Having layers of felted hair worked between the soles, unpleasant creaking is avoided, and elasticity and warmth imparted.

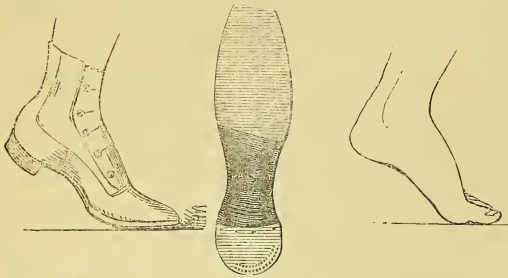

Messrs. Taylor and Bowley's Patent Elastic Waist Boots.
(179, 180, 181, *Main Avenue, West*).

- 182 HALL, R., 97A *Quadrant, Regent Street*—Inventor and Manufacturer.
Boots and shoes of elastic enamelled cloth, for tender feet.
India-rubber goshes and fishing-boots.
- 182A DODSON, J., 79 *Chiswell Street*—Manufacturer.
Ladies' and gentlemen's boots, shoes, and slippers.
- 183 GATES, THOMAS FREDERICK, 5 *Upper Eaton Street, Picnic*—Designer and Manufacturer.
Wigs, showing a transparent parting, free from "roots" or short hair, and other improvements.
- 184 HODGES, T., 316 *Oxford Street*—Manufacturer.
Self-adjusting shoe, in ordinary leather enamel, and in buckskin, showing the effect of a composition for filling up and waterproofing the surface, and its susceptibility of receiving a polish.
Plan for removing the appearance of bunions.
Boots in illustration of the self-adjusting principle.
- 186 PATTISON, EDWARD, 74 *Oxford Street*—Manufacturer.
Ladies' boots and shoes.
- 188 BARKER, WM. GEORGE, 18 *Old Cavendish Street*—Inventor and Manufacturer.
Pair of gentleman's Oxonian shoes, closed by an invisible elastic fastening. Registered pair for a lady.
- 189 BIRD, WILLIAM, 86 *Oxford Street*—Inventor and Manufacturer.
Ladies' elastic boots, without any gusset at the sides. Registered boots without any seam up the front.
- 190 WILDSMITH, MATTHEW, 1 *Sherrard Street, Golden Sq.*—Inventor and Manufacturer.
Flexible Wellington boots, with springs at the sides.
- 191 CLARKE, EDWARD WM., 12 *Southampton Row, Bloomsbury*—Manufacturer and Inventor.
Boots and shoes of various kinds and styles. Casts and lasts for deformed feet, &c.
- 192 HICKSON & SONS, 20 *West Smithfield*—Manufacturers or Designers.
Boots and shoes, of various qualities and forms, including specimens with elastic fronts and sides, gutta percha and cork soles.
Specimens of the various kinds of boots and shoes, supplied for the use of the British army and navy, the police, and the public institutions.
Specimens of winter boots and shoes, made of patent machine-felt.
Samples of the material employed in the manufacture.
- 194 HUBERT, CHARLES, 292 *Regent St.*—Manufacturer.
Wellington, top, elastic, registered, and other boots and shoes.
A boot and shoe made from a single piece of leather.
- 195 HEATH, STEPHEN H., 38 *Poultry*, and 17 *St. Martin's-le-Grand*—Designer.
Boots and shoes of soft leather.
Patent waterproof and other leather boots and shoes, for dress or walking.
Boots and shoes of ordinary calf-skin.
- 196 CROW, THOMAS, 3 *Maidenhead Court, Cripplegate*—Designer, Manufacturer, and Proprietor.
A patent leather boot, with shell heel, satin waist, and square edge; the heel, two inches high, is composed of fifty lifts, worked in the style of a shell, the substance of each being one-eighth of an inch.
Pair of full-dress boots.
- 197 PEAL, NATHANIEL, 11 *Duke Street, Grosvenor Square*—Manufacturer.
Half-leg hunting boots, and whole-leg hunting or fishing boots, of waterproof leather.
- 198 CREMER, GEORGE, & Co., *Old Kent Road*—Manufacturers and Inventors.
Registered Wellington boots, made on a new principle; one exhibited in a complete state, and the other in the course of manufacture.
- 199 ROBOTHAM, SAMUEL, 28 *Newton Street, Birmingham*—Manufacturer.
Clogs, made of gutta percha, leather, and wood, with patent fastening.
- 200 BROTCHIE, RICHARD, 3 *Oxendon Street, Haymarket*—Inventor and Proprietor.
Patent vulcanized plate for boots and shoes, to resist wet or damp.
Six pairs of boots and shoes with vulcanized soles.
- 201 NORMAN, SAMUEL WILLS, 4 *Oakley Street, Westminster Road*—Inventor and Manufacturer.
Ladies' cork and leather boots, waterproof, and light. Ladies' shoe; the heel of which will retain its polish.
- 202 HOBY, GEORGE, 48 *St. James's Street*—Manufacturer.
Napoleon boots, made of waterproof leather. Top boots, Wellington boots, and Oxford shoes, of the same material. Specimens of the leather, unmanufactured. Composition with which the articles are cleaned.
- 203 SCHALLER, J., 19 *Charles Street, Middlesex Hospital*—Inventor and Manufacturer.
New water-proof boots and shoes and overshoes. Clogs, elastic gaiters, boots, &c.
- 204 RIDLEY, J., *St. Paul's Churchyard*—Manufacturer.
Ladies' boots and shoes.
- 205 WILSHIN, S. B., 86 *Albany Road, Camberwell*—Manufacturer.
Skating-boots on a new principle.
- 206 WALKER, EDWARD, 19 *Whitecross Place, Wilson St., Finsbury*—Designer and Manufacturer.
Registered ladies' elastic Victoria riding and walking boot.
- 207 WALSH, WILLIAM, 9 *Clipstone Street, Portland Road*—Manufacturer and Designer.
A pair of shoes.

208 STANLEY, C., 238 *High Street, Borough*—Inventor.

Model of a shoe, composed of black ebony, with gold buckle and studs, placed on a stand made of king-wood, comprising 74 pieces. A specimen of workmanship for cordwainers.

209 SALTER, GEORGE, 46 *Windsor Street, Islington*—Inventor and Manufacturer.

Pair of new-invented cork boots, waterproof in the soles, independently of the cork, and waterproof round the sides of the upper to the extent of one inch, so as to allow ventilation. The cork inside is uncovered, and so constructed as not to be displaced by wearing. Adapted for ladies' riding and walking boots.

210 POLLETT, THOMAS, *Earl's Court, Kensington*—Inventor and Manufacturer.

Wellington boots, with revolving leather heel; ladies' boots, with revolving brass heel; three model revolving heels.

211 THOMAS & SON, 36 *St. James's Street*—Manufacturers.

Jack-boot, regulation for the Household cavalry. Stout hunting, racing, Wellington, laced shooting, silk stocking spring, hessian, button, and other boots.

Highland brogues. Model pump. Regulation steel and gilt spurs.

212 GORDON, EDWIN, 6A *Princes Street, Leicester Square*—Inventor and Manufacturer.

Screw clump-sole boots, with pegged waist.

213 MITCHELL, FREDERICK, 8 *Cartwright Street, Royal Mint*—Maker and Proprietor.

Ladies' cork sole boots, made of royal purple silk velvet, embroidered with rose, shamrock, and thistle, and the oak and laurel.

215 CURRIE, JAMES, 3 *Panton Street, Haymarket*—Inventor and Manufacturer.

Improved waterproof boots.

216 FAULKNER, OLIVER, 30 *Wigmore Street, Cavendish Square*—Inventor and Maker.

Pair of waterproof fishing or shooting boots.

219 BRIDGES, CHARLES H., 57 *Charlotte Street, Portland Place*—Inventor and Manufacturer.

Registered rotary heel for boots and shoes, made either in leather or wood, completely detached from the boot or shoe. When the leather or wood is worn away, it can be renewed with very little trouble and expense, while the metallic part will last for a considerable period.

220 BECKETT, GEORGE, 41 *Fenchurch Street*—Manufacturer.

Various boots.

222 LANGDALE, HENRY, 57 *Mount Street, Grosvenor Square*—Manufacturer.

Children's boots and shoes, in various forms and materials; the binding or needlework by Ann and Helen Langdale. Side-button boots stiffened round the ankles.

224 ROBERT, A., 123 *Regent Street*—Manufacturer.

Boots.

227 GRUNDY, THOMAS, 44 *St. Martin's Lane, and 133 Leadendall Street*.

Boots made of leather prepared by a new process, which renders them soft and pliable, having a fine polish, and requiring no blacking.

228 SCOTT, S. T., 1 *Union Street, Southwark*—Inventor.

Various registered adjusting lasts, with metallic slides for removable toes.

230 GARNER, DAVID, 41 *Finsbury Market*—Manufacturer and Designer.

Portable boot-trees of one leg only, comprising the means of treeing five different kinds of boots and shoes; containing also a set of blacking-brushes, blacking, boot-hooks, powder-box, &c.

Boot-lasts, adapted for diseases of feet, bunions, &c. Wellington boot lasts. Boot and shoe lasts.

235 GEARY, NICHOLAS, 61 *St. James's Street*—Inventor and Manufacturer.

Improved jack boots.

Regimental gloves, intended to show an improvement in the gauntlet.

236 BOWLER, JAMES, 2 *Little Portland Street*—Manufacturer.

Lasts, trees, and stretchers for ladies' and gentlemen's boots.

237 SMITH, J., *Bedford*—Inventor and Patentee.

Soccopedes elasticus. Ladies' boot.

238 HEWLETT, ANTHONY, 5 *Burlington Arcade*—Part Inventor.

Busts of Her Majesty, His Royal Highness Prince Albert, and the Prince of Wales; exhibited to display a new method of artificial hair without springs, elastics, or ribbons.

240 BUTTERWORTH, WILLIAM, & Co., 9 *Great Dover Street, and 4 Swan Street, Southwark*—Inventors and Manufacturers.

The registered Panelastic boot; obviating the unsightly appearance and other disadvantages of inserted gores.

241 MARSHALL, C., 207 *Oxford Street*—Manufacturer.

Ladies' boots and shoes.

242 PARKER, JOHN, 35 *Dame Street, Dublin*—Manufacturer.

Boots:—Gentlemen's enamelled leather brown top; patent Napoleon; cork-sole walking; patent leather dress; and dress opera; with various others. Morocco leather slippers, embroidered with royal arms in gold.

Ladies' white tabinet and black satin spring-side boots and dress shoes. Button walking shoes. Kid boots. Cork-sole boots. All made of Irish materials and manufacture.

243 WEBB, EDWARD, *Worcester*—Manufacturer.

Coloured hair-cloth, and cloth composed of hair and silk, for covering chairs, sofas, &c.

Horse-hair carpet, woven like Brussels carpet, and suitable for halls, offices, churches, &c.

244 BURGESS, R., 15 & 16 *Opera Arcade, Charles Street, St. James's*—Inventor and Manufacturer.

Improved wig. New hair-brushes. Bandoline.

245 BROWNE, FREDERICK, 47 *Fenchurch Street*—Manufacturer and Designer.

Ladies' and gentlemen's head-dresses of ornamental hair.

246 BOUCHET, C., 74A *New Bond Street*—Manufacturer.

Specimens of the new improved crochet-work in wig making, on skin and on net. The mechanism on the moving scalp is to show the difference in the appearance of a head with and without a scalp.

247 BECK, ROBERT, 79 *Cheapside*—Manufacturer.

Lady's head dress, gentleman's peruke, front head dresses, piece of straight hair, &c., showing the improvements made in wig making during the past ten years.

248 ROSSI, LOUIS, 254 *Regent Street*—Inventor and Manufacturer.

Wigs of various kinds.

249 WINTER, WILLIAM, 205 *Oxford Street*—Inventor.

Transparent wigs for ladies and gentlemen; head-dresses, &c.

250 PREVOST, MARK, 100 *St. Martin's Lane, Westminster*—Inventor and Maker.

A wig, from which the transverse elastic band (that covers the apex of the temples of the wearer) is removed, and circulation in the arteries preserved. The metal cross spring (used in open temple wigs) to grasp the head is not employed. The invention consists of two springs placed over the temples, which expand while the wig is being drawn on, and collapse to hold it on permanently.

251 CARLES, H. R., 45 *New Bond Street*—Inventor and Manufacturer.

Large wax head, with white bald knotted wig; the same with knotted false-hair beard.

A wig, knotted on strong material.

Lady's head-dress, with transparent division.

Bald white wig, with skin top, made with braid.

Transparent scalp.

Gentleman's wig, the division made of hair only; the same with transparent division.

253 ISIDORE & BRANDT, 217 *Regent Street*—Inventors and Manufacturers.

White wig, with the arms of England formed by work in hair. Peruke à la Marie Stuart. Powdered wig, in the reign of Louis XV. Lady's wig, after nature. Various wigs, fronts, and curls, produced by a new process.

255 WORN, RICHARD, 17 *Dawson Street, Dublin*—Manufacturer.

"Gossamer" transparent Temple spring wig, with cross division; and with parting of crape. Weft, with skin parting, to avoid contraction, &c.

256 MADDEN & BLACK, *Capel Street, Dublin*—Manufacturers.

Ladies' and gentlemen's perukes, with skin partings, and with transparent partings. Ladies' fronts, and a gentleman's peruke, with gossamer parting. Improved bar wig.

257 DOUGLAS, R., 34 *North Audley Street*—Inventor.

Lady's head-dress. The hair is 7 feet long, being joined together so as to appear of one length.

Circular hair brushes, capable of revolving either way, or of being used as an ordinary brush.

259 CAUSSE, D. A., 267 *Regent Street*—Manufacturer.

Ladies' hair fronts, on transparent silk net, in various styles.

Ladies' and gentlemen's perukes, on fine Malines silk net, and inserted through the skin.

Gentleman's scalp.

260 MUSSA, MICHEL, 4 *Victoria Road, Pimlico*—Inventor and Manufacturer.

Improved specimens of theatrical wigs and beards.

261 PICOTT, JOSEPH, *Cork*—Manufacturer.

A lady's head-dress, intended as a useful and ornamental substitute for the natural hair; it is light and transparent, each hair being set in singly.

262 ROBEX, W. *Richmond, Surrey*—Inventor.

Ladies' head-dress.

264 TYZACK, W. V., *Norwich*—Manufacturer.

Specimens of false hair, which show the skin of the head between every hair.

265 O'LEARY, JOHN, 53 *South Mall, Cork, Ireland*—Manufacturer.

Improved gentleman's wig, each hair has been worked

in separately on the net, which constitutes the ground or frame work, and renders it transparent.

266 KELSEY, JOHN TURNER, *Lingfield, East Grinstead*—Manufacturer.

Crop hide of North Wales runt, of the great weight of 82 lbs., tanned with Sussex oak-bark; used for boot and shoe soles, and for machinery. Prepared at Batnor's tan-yard, in Lingfield. The tanning occupied two years.

[The process of tanning—that is, of the combination of the tannic acid of the oak bark with the gelatine of the hide—is generally a slow one; in the present instance remarkably so. New methods of hastening it forward have been introduced; but it is said that the leather thus produced is not equal in solidity and durability to that obtained in the ordinary slow manner.—R. E.]

267 DUCIE, EARL, *Tortworth Court, Wotton-under-Edge, Gloucestershire*—Proprietor.

Cart harness, for agricultural and other purposes, with Vick's improved registered hames—constructed to give facility of draught by raising or lowering the huffing-tugs. The cart-saddle and collar are made of patent leather, with rollers in the tree of the cart-saddle upon which the back-band works freely. Made by Richard Vick, saddle and harness maker, Gloucester.

269 TAYLOR, T., *Banbury, Oxon*—Inventor.

Ladies' and gentlemen's riding-saddles, inflated with air. Hunting-saddles, with patent moveable panels. Registered bits, various webs, &c.

270 OAKLEY, TOM, *Maldstone*—Designer and Manufacturer.

Lady's saddle, quilted all over, with fancy wool-work introduced. The off-side head is dispensed with, and lightness made an object.

271 SAUNDERS, FRANCIS WOOLHOUSE, *Thame, Oxon*—Manufacturer.

A four-horse cart harness, for agricultural and general purposes; the blinkers made with plates, similar to carriage harness, preventing any injury to the eyes.

272 BLOWERS, WILLIAM RANDALL, *High Street, Maldon, Essex*—Manufacturer.

Variety of harness for draught horses.

273 COWAN, LACHLAN, *Barrhead, New Paisley*—Producer.

Set of cart harness.

275 COX, THOMAS, *Buff Coat Lane, Norwich*—Designer and Manufacturer.

Pony harness, woven from flax grown in Norfolk.

Fancy baskets, woven from the same materials.

277 CHARGE, ROBERT, *Horse Market, Darlington, Durham*—Manufacturer.

Saddle, adapted for riding or hunting, light in weight, and new in style.

278 DAX, RICHARD, *High Street, Welshpool, North Wales*—Inventor.

Harness and riding bridles, with noseband horse-stopper attached.

279 POLLOCK, JAMES, 151 *Stockwell Street, Glasgow*—Manufacturer.

Complete set of Scotch horse harness, including the various articles that a horse requires when in yoke.

283 COZENS & GREATREX, *Walsall*—Manufacturer.

Tanned and curried leather for bridles and reins; and for stirrup leathers.

Curried hog-skins for saddles. Seal-skins for saddle-welts.

284 RANDALL & DICKS, 21 *Greek Street, Soho*—Manufacturers.

Skins for oil leather, in raw state and in various stages of manufacture. Buck, doe, calf, sheep, and lamb skins, finished; with specimens in breeches, gloves, braces, and pianoforte hammers.

285 PULLMAN, R. W. & J., 17 *Greek Street, Soho*—Manufacturers.

Specimens of oil leather in various stages of dressing, viz., buck, doe, fawn, buffalo, calf, sheep, and lamb skins.

[The process of oil or chamois leather dressing, as practised in England, consists in beating fish oil into the pores of the skin, and afterwards partially drying or oxygenating the oil. When the skin is perfectly saturated by the repeated process of hammering in the mill, and partial drying, it is allowed to become hot by natural fermentation, and then, by washing in strong alkali, becomes the softest and most pliable of all kinds of leather.]

286 OASTLER & PALMER, *Grange Road, Bermondsey*—Manufacturers.

Japanned border, bag, horse, and split hides. Black, green, blue, drab, maroon, crimson, and brown enamelled hides. The border hide is manufactured from the hide of an ox, being (as far as practicable) left the whole thickness; the other hides (with the exception of the horse) are the same description of hide, split by machine to any required thickness; thus making two, whereas formerly the hide had to be shaved to the proper thickness by manual labour.

The japanned split hide shows the flesh side curried and japanned for coach purposes.

288 JACKSON, ROBT. B., 9 *Hampstead St., Fitzroy Square*—Inventor.

New mode of cleaning and restoring worn and decayed Morocco leather, for upholstery purposes, coach linings, &c.

289 GEORGE, JOSEPH, 81 *Dean Street, Soho*—Manufacturer.

Gilt and painted leather, capable of being made of any width and length, for the hangings of rooms, screens, &c. Various specimens of ornamental leather, borderings for table-tops, edges of book-shelves, covering furniture, hassocks, &c.

Embossed and gilt leather, of different lengths, for the hangings of rooms, screens, &c., in every variety of style.

290 DIXON & WHITING, *Manning Street, Bermondsey*—Manufacturers.

Samples of enamelled, japanned, and coloured hides; among which is one of the largest hide splits, curried; and also a hide split into three, the grain enamelled, and the two splits japanned.

[The machine by which a skin is split into two or three portions is of beautiful and ingenious construction. It consists essentially of two grooved rollers, which seize the skin and present it to the edge of a rapidly-moving horizontal knife, by which it is speedily split into halves. The relative thickness of the halves can be adjusted by set-screws.]

293 BOUTCHIER, MORTIMER, & Co., *Bermondsey*—Proprietors and Leather Factors.

Hides, leather, and tanning materials.

294 BOSSARD, JOHN, 7 *Church Street, Russell Street, Bermondsey*—Manufacturer.

British calf skins, tanned and dressed (Paris and Bordeaux fashion), with oak bark and other English ingredients.

Boot fronts from similar skins, blocked and finished.

297 TOMBS, E., *Theberton Street, Islington*—Producer. English calf skin.

298 BRANSCOMBE, S., *Liverpool*—Manufacturer.

Tanned buffalo hides, imported into London in a salted state from the Cape of Good Hope, in 1847, and tanned at Lynn, in Cheshire.

299 HEINTZE, L., 1 *School Lane, Liverpool*—Importer.

Black japanned calf-skins, tanned and prepared by Heintze and Freudenberg, Weinheim, near Mannheim, on the Rhine.

300 BROWN, A., *Milsom Street, Bath*—Inventor.

Peruke, manufactured without stitching.

301 HUDSON'S BAY COMPANY—Producers. (*Main Avenue West.*)

Specimens of skins from the Arctic Regions, belonging to the HUDSON'S BAY COMPANY, selected for the Exhibition from their importation of 1851; prepared and arranged by the exhibitors, from No. 1 to No. 27.

[The immense tracts of country over which the Hudson's Bay Company has control may be considered as vast hunting-grounds, affording a varied and exhaustless supply of furs. The territorial possessions of this Company cover nearly one-eighth of the habitable globe. Russia is next in order and importance in this respect, but with a different race of animals. The fur produce of North America and the Canadas is also important. As we approach the tropics and the warmer regions, the silky fur with which the animals are clothed in the northern climes disappears, and fur of a totally different character is met with, which, although splendid in appearance, is not adapted for warmth or general use.

TABLE OF IMPORTS and EXPORTS.

	Total Importation into England.	Exported.	Consumed in England.
Racoon	525,000	525,000	None.
Beaver	60,000	12,000	48,000
Chinchilla	85,000	30,000	55,000
Bear	9,500	8,000	1,500
Fisher	11,000	11,000	None.
Fox red	50,000	50,000	None.
" cross	4,500	4,500	None.
" silver	1,000	1,000	None.
" white	1,500	500	1,000
" grey	20,000	18,000	2,000
Lynx	55,000	50,000	5,000
Martin	120,000	15,000	105,000
Mink	245,000	75,000	170,000
Musquash	1,000,000	150,000	850,000
Otter	17,500	17,500	None.
Fur seal	15,000	12,500	2,500
Wolf	15,000	15,000	None.

EUROPEAN FURS.

	Imported.	Exported.	Consumed in England.
Martin, Stone, and Baum . . .	120,000	5,000	115,000
Squirrel	2,271,258	77,160	2,194,098
Fitch	65,091	28,276	36,815
Kolinski	53,410	200	53,210
Ermine	187,104	None.	187,104

—J. A. N.]

1. Group of black and silver foxes (*Vulpis fulvis*, var. *Argentatus*).
2. Group of foxes (*Vulpis fulvis*, var. *Decussatus*).
3. Group of red and silver foxes (*Vulpis fulvis*).
4. " white " (*Vulpis lagopus*).
5. " kitt " (*Vulpis velox*).

[The black and silver fox is the most valuable of his tribe: they are generally purchased for the Russian and

Chinese markets, being highly prized in these countries. The cross and red fox are used by the Chinese, Greeks, Persians, &c., for cloak-linings and for trimming dresses. The white and blue fox is used in this and other countries for ladies' wear. In the sumptuary laws passed in the reign of Henry III., the fox is named with other furs then in use.—J. A. N.]

6. Group of otter (*Lutra Canadensis*).

[The Hudson's Bay North American and European otters are chiefly exported for the use of the Russians, Chinese, Greeks, and others, for caps, collars, trimming national dresses, robes, &c. Upwards of 500 otters, the produce of Great Britain, during the last year, were exported.—J. A. N.]

7. Group of beaver (*Castor Americanus*).

[The beaver in former years was one of the Hudson's Bay Company's most valuable productions; but since its use has been almost entirely discontinued in the manufacture of hats, it has lost much of its value. Experiments have, however, been made, and with prospect of success, to adapt its fine and silky wool to weaving purposes. The skin of the beaver is prepared by a new process, after which the surface is cut by a new and ingenious machine, and the result is a beautiful fur for ladies' wear. It is exported in its prepared state to various parts of Europe and the East. The rich white wool from the under part of the beaver is largely exported to France.—J. A. N.]

8. Group of lynx (*Felis Canadensis*).

9. ,, lynx cat (*Felis Rufa*).

[Both the above furs, when dyed, were formerly much used. It is still dyed and prepared, and exported in large numbers for the American market. In its natural state, it is a greyish white, with dark spots, and is used by the Chinese, Greeks, Persians, and others, for cloaks, linings, facings, &c.: it is very soft, warm, and light. The fur formerly called the lucern is the lynx.—J. A. N.]

10. Group of wolf (*Canis Occidentalis*).

11. ,, fisher (*Mustela Canadensis*).

12. ,, wolverin (*Gulo luscus*).

[The wolves are generally used as cloak and coat linings in Russia, and other cold countries; also for sleigh-coverings, and open travelling carriages. The other skins enumerated are principally used for trimmings, linings, &c. The tail of the fisher is very valuable, and exclusively used by the Jews.—J. A. N.]

13. Group of badger (*Taxidea Labradoria*).

[The North American badger is exported for general wear; its soft fine fur renders it suitable for that purpose. The European badger, on the contrary, from the nature of its hair, is extensively used for the manufacture of shaving brushes.—J. A. N.]

14. Group of martin or sable (*Mustela martes*).

[The Hudson's Bay martin is consumed in large quantities in this country, in France, and in Germany. The lining of a mantle made of black sables, with white spots, and presented by the Bishop of Lincoln to Henry I., was valued at 100*l*. In Henry the Eighth's reign, a sumptuary law confined the use of the fur of sables to the nobility above the rank of viscounts.—J. A. N.]

15. Group of mink (*Mustela vison*).

[The mink is exclusively the produce of the Hudson's Bay possessions and North America; it is consumed in Europe in immense numbers, principally for ladies' wear.—J. A. N.]

16. Group of musquash, or musk-rat (*Fiber zibethicus*).

[The musquash, or large American musk-rat, is imported into this country in immense numbers: it was formerly much used in the manufacture of hats, but the introduction of the silk hat has entirely superseded its use; and the fur is employed for wear after having undergone preparation.—J. A. N.]

17. Group of weenusk (*Arctomys empetra*).

18. ,, swan (*Cygnus ferus*).

19. ,, white hare (*Lepus glacialis*).

20. ,, rabbits (*Lepus Americanus*).

[The Hudson's Bay rabbit is one of the least valuable skins imported by this Company: like all furs from the Polar regions, its hair is fine, long, and thick, but the skin is so fragile and tender that it is almost useless.—J. A. N.]

21. Group of black bear (*Ursus Americanus*).

22. ,, brown bear (*Ursus*, var. *Americanus*).

23. ,, grey bear (*Ursus ferax*).

[The large North American black bear is technically termed the army bear, because it is generally used for military purposes in this and other countries, for caps, pistol-holsters, rugs, carriage hammercloths, sleigh coverings, &c. The fine black cub bears are much sought after in Russia for making shube-linings, coat-linings trimmings, facings, &c. The other sorts, with the large grey bears, for sleigh-coverings and accompaniments, &c. The white Polar bear, the supply of which is very limited, is generally made into rugs, which are often bordered with the black and grey bear. The brown or Isabella bear is at the present time used for ladies' wear in America.—J. A. N.]

24. Group of sea-otter (*Eutrydra maritima*).

[The sea-otter is most sought after by the traders, on account of its great commercial value: it is said to be the royal fur of China, and is much used by the officers of state, mandarins, &c. It is in great esteem in Russia, and principally worn by gentlemen for collars, cuffs, facings, trimmings, &c. On account of its great weight, it is rarely used by ladies.—J. A. N.]

25. Group of swan quills.

26. ,, goose quills.

27. ,, isinglass in its natural state.

[This specimen is in its original state; by a subsequent process it is prepared for domestic use.—J. A. N.]

301A NICHOLAY, JOHN AUG., & SON, 82 Oxford Street—
Collectors, Importers, Manufacturers, &c.

Selected from CANADIAN importation, with the assistance
of C. M. Lamson, Esq.

(Main Avenue, West.)

28. Group of racoon (*Procyon lator*).

[The finest racoon furs are produced in North America, and are imported into this country in immense numbers. They are purchased here by the merchants who attend the periodical fur sales, and who dispose of large quantities at the great fair at Leipsic: they are principally used in Russia, and throughout Germany, for lining shubes and coats, and are exclusively confined to gentlemen's wear. The dark skins are the choicest, and are very valuable.]

29. Group of cat lynx (*Felis Rufa*).

30. Group of mink (*Mustela vison*).

31. Group of grey fox (*Vulpis Virginianus*).

[The Virginian, or North American grey fox, is the

produce of the Canadas, Newfoundland, Labrador, &c., and is at present much used for open-carriage wrappers.]

EUROPEAN FURS, selected by the exhibitors.

32. Group of Russian sable (*Martes zibellina*).

[The Russian or Siberian sable is one of the most costly furs, and is manufactured into linings, which are generally used as presents by great potentates, being of the value of 1000 guineas and upwards. The Lord Mayor, Aldermen, and Sheriffs, &c., of the city of London, have their robes and gowns furred with this sable according to their respective ranks. The tail of the sable is also used in the manufacture of artists' pencils or brushes. Russia produces about 25,000 of these valuable and esteemed skins annually.]

33. Group of stone martin (*Martes bobolivaris*).

[The stone martin is widely spread over Europe, and derives its name from the fact of its selecting rocks, ruined castles, &c., as its haunts. The French excel in dyeing this fur, and it is in consequence termed French sable.]

34. Group of baum martin (*Martes abietum*).

[The baum or wood martin is so named from its being invariably found in woods and pine forests in Europe. The fur in its natural state is similar to the North American sable, but coarser. It is distinguished by the bright yellow colour of its throat; when dyed, the fur closely resembles the real sable.]

35. Group of ermine (*Mustela erminea*).

[The ermine is produced in most countries; but the best is from Russia, Sweden, and Norway, and is killed in winter when the fur is pure white (except the tail, with its jet black tip), it being at that season in its greatest perfection: in summer and spring it is grey and of little or no value. It is the weasel of more southern climes. The ermine is the royal fur of Russia, Germany, Spain, Portugal, Italy, &c. In England, at the coronation of the Sovereign, the minever, as the ermine is styled in heraldic language, is used, being powdered, that is, studded with black spots; the spots or powdered bars on the minever capes of the peers and peeresses being in rows, and the number of rows or bars denoting their various degrees of rank. The sovereign alone and the blood royal having the minever of the coronation robes powdered all over, a black spot being inserted in about every square inch of the fur, crimson velvet being used on that occasion. The crown is also adorned with a band of minever, with a single row of spots; the coronets of the peers and peeresses having a similar arrangement. The black spots are made of the black Astracan lamb. On state occasions, in the House of Lords, the Peers are arrayed in their robes of state, of scarlet cloth and gold lace, with bars or rows of pure minever, more or less according to their degrees of rank; the sovereign alone wearing the royal minever, powdered all over. The Judges in their robes of office are clad in scarlet and pure ermine. The ermine, with the tail of the animal inserted therein, is used as articles of dress for ladies, in every variety of form and shape, according to the dictates of fashion, and also as cloak linings. The minever can only be worn on state occasions by those who, by their rank, are entitled to its use; but as an article of fashion for ladies' wear there is no prohibition in force. In the reign of Edward the Third, furs of ermine were strictly forbidden to be worn by any but the royal family, and its general use is prohibited in Austria at the present

time. In mercantile transactions, ermine is always sold by the timber, which consists of 40 skins. The minever fur of a former era was the white belly of the grey squirrel.]

36. Group of kolinski (*Mustela Siberica*).

[The kolinski or Tartar sable is procured from Russia, belongs to the weasel tribe, and is in colour a bright yellow; it is much used in its natural state, and also dyed to imitate the cheaper sables.]

37. Group of squirrel, black (*Sciurus Niger*).

38. " squirrel, blue (*Sciurus*, var. *Niger*).

39. " squirrel, kasan (*Sciurus*, var. *Griseus*).

40. Ditto squirrel, red (*Sciurus vulgaris*).

[The squirrel abounds in Russia (where it is produced in the greatest perfection), in such immense numbers as would appear almost incredible; the importation from thence to this country alone, last year, exceeding 2,000,000. The celebrated Weisenfels lining is made from the white part of the dark-blue squirrel. A full-sized cloak-lining weighs only 25 ounces: it is known as the *petit gris*. For colder climates the linings are made from the back or plain grey part of the squirrel, the best having part of the tail left on each skin. Russia produces about 23,000,000 annually.]

41. Group of fitch or pole-cat (*Putorius feticus*).

[About 40 years since this fur was more largely used than at present. It is produced in the greatest perfection in this country.]

42. Group of Crimea grey lamb.

43. " Ukraine black lamb.

44. " Astracan black lamb.

45. " Astracan grey lamb.

46. " Persian black lamb.

47. " Persian grey lamb.

48. " Spanish lamb.

49. " Hungarian lamb.

50. " English lamb.

[The grey and black Russian lamb is mostly used for gentlemen's cloak and coat linings, for facings, collars, caps, &c., and also for army purposes. The Astracan lamb is a rich, wavy, glossy, black skin, very short in the fur, having the appearance of beautiful watered silk: in order to obtain this choice skin, it is averred that the parent sheep is destroyed a certain time before the birth of the lamb. The Persian, grey, and black lamb, is covered with very minute curls; this is produced, it is said, by the animal being, as soon as born, sewn up tightly in a leathern skin, which prevents the curl expanding. The Hungarian lamb is produced in that country in immense numbers; of it the national coat, called the *Juhasz Bunda*, is made. In the summer or wet weather the fur or woolly part is worn outside; in winter, when warmth is required, it is reversed: the skin is tanned or dressed in a way peculiar to the country, and decorated and embroidered in accordance with the means and taste of the wearer. In Spain, the lamb is used for the well-known and characteristic short jacket of that country, which is adorned with filigree silver buttons; the coarser kinds of both colours are used for our cavalry, and is also employed for mounting and bordering skins, as leopards, tigers, &c. for ornamental and domestic purposes. In the reign of Richard the Second, the sergeant at law wore a robe furred inside with white lambskin and a cape of the same.]

51. Group of Perewaitzki.

52. " Hamster.

[The above are from Russia; the former is used by

ladies, the latter is made into cloak-linings, which are exceedingly light, durable, and cheap.]

- 53. Group of coloured cat.
- 54. „ black cat.
- 55. „ black Dutch.
- 56. „ coloured Dutch.

[The cat, when properly attended to, and bred purposely for its skin, supplies a most useful and durable fur; in Holland it is bred and kept in a confined state till the fur is in its greatest perfection, and is fed entirely on fish. In other countries, and especially in our own, it is produced in large numbers. The wild cat is much larger and longer in the fur, and is met with in extensive forests, particularly in Hungary; the colour is grey, spotted with black, and its softness and durability render it suitable for cloak and coat linings, for which purpose it is much used. The black species is also much in request, and similarly used, and, with the spotted and striped varieties, is made into wrappers for open carriages, sleigh coverings, and railway travelling.]

57. Group of English rabbit, silver grey, (*Lepus cuniculus*); presented by Her Grace the Duchess of St. Albans.

- 58. Group of English black rabbit (*Lepus* var).
- 59. „ English white rabbit.
- 60. „ English grey rabbit.
- 61. „ Flemish blue rabbit.
- 62. „ Polish white rabbit.

[The English rabbit, both in its wild and domestic state, abounds in such numbers that the supply is inexhaustible: it was formerly employed to make the felt bodies or foundation for the beaver hat; at present, not being used for that purpose, it is dressed, dyed, and manufactured in immense quantities into various useful articles. The wool has recently been used in making a peculiar cloth, adapted for ladies' wear. The English silver-grey rabbit was originally a breed peculiar to Lincolnshire, where great attention was paid to it. Warrens have since been formed in various parts of the country. It is in great demand in China and Russia, to which countries it is invariably exported, on account of the high price there obtained. The white Polish rabbit is a breed peculiar to that country. The finer sorts of white rabbit are much used as substitutes for ermine. So late as the reign of Henry the Eighth, such importance was attached to the coney or rabbit skin, that the charter of the Skinners' Company shows they were worn by nobles and gentlemen. Acts of Parliament were passed regulating their sale and exportation, which are still in existence.]

63. Group of European grey hare (*Lepus timidus*).

Seal (*Phoca*),

64. Group of seal, GEORGIA, SHETLAND ISLES, FALKLAND ISLES, LOMAR'S ISLAND, and CAPE.

- 65. Group of plucked and prepared seal, natural colour.
- 66. „ plucked and prepared seal, dyed.
- 67. „ Greenland and Newfoundland seal.
- 68. „ Greenland and Newfoundland seal, dyed.
- 69. „ spotted and silver seal.

[The seal is an inhabitant of most countries; it is found in the high northern latitudes in immense numbers; ships are purposely fitted out for its capture; the oil produced by the animal, together with its skin, render it (connected as it is with the whale fishery) important to the trader, and interesting to the naturalist. The skins are salted and packed in casks, in which state they are sent to this country; they are then sorted and selected

for various purposes; those suitable for leather pass into the tanners' hands, and make a beautiful leather, which is used for ladies' shoes. The blue back, the hair, and the silver seal, are dressed and used in their natural state, and also dyed and exported in large quantities. The fur seal, the supply of which is always small compared with the other kinds, undergoes a process to prepare it for its intended use. It is brought at the present time to a great degree of perfection in this country; when divested of the long coarse hair (which protects it in its native element) there remains the rich, curly, silky, yellowish down, in which state it was formerly used for travelling caps and other purposes. It is now seldom made use of in that state, but dyed a beautiful Vandyke brown, giving it the appearance of the richest velvet, and is manufactured, in every variety of shape and form, as articles of dress for ladies', gentlemen's and children's wear.]

The dressing, preparing, and unhairing, has been effected by Mr. Collins, Earl-street, Finsbury Square.

South American.

- 70. Group of chinchilla, Buenos Ayres (*Chinchilla lanigera*).
- 71. Group of chinchilla, Arica (*Chinchilla lanigera*).
- 72. Group of bastard chinchilla or Lima (*Chinchilla lanigera*).

[The chinchilla is exclusively a South American animal, and was introduced into this country and France about forty years since.]

From the Tropics, &c.

- 73. Group of lions (*Felis leo*).
- 74. „ royal tigers (*Felis tigris*).
- 75. „ Cape tigers (*Felis leopardus Africanus*).
- 76. „ leopards (*Felis leopardus*).
- 77. „ panther (*Felis onca*).
- 78. „ chétar.

[In China, the mandarins cover the seat of justice with the tiger. In this country the collocation of the leopard under the officer's saddle is a distinguishing mark, adopted by some of Her Majesty's cavalry regiments. In Austria, the small fine leopard is worn as a mantle by the Hungarian noblemen, who exclusively form the royal hussar body guard.]

- 79. Group of zebra (*Equus zebra*).
- 80. „ antelope (*Antelope oreotragus*).
- 81. „ black monkey (*Colobus ursinus*).
- 82. „ ant-eater (*Myrmecophaga jubata*).
- 83. „ moose deer (*Cervus alces*).
- 84. „ deer.
- 85. „ Australian (*Dasyurus viverrinus*).
- 86. „ Indian ground squirrel (*Sciurus palmarum*).
- 87. „ flying squirrel (*Sciurus pelaurus*).
- 88. „ Angora goat (*Capra hircus*).
- 89. „ dyed Angora goat, various.

[The Angora goat is produced in large numbers in Asia Minor, and is remarkable for its long, curly, rich, white silky coat; it was formerly a most costly article of ladies' wear, but is at the present time of little value. It is dyed, and takes some of the most beautiful and brilliant colours. It is made into beautiful rugs for drawing-rooms, carriages, &c.]

- 90. Group of beaver, prepared by a new process.
- 91. „ beaver, dyed.

Exhibited to illustrate an entirely new method of preparing the beaver, and adapting it for general use. Dressed and cut by Messrs. Lee & Son, Southwark.

92. Group of unhaired or pulled dyed otter.

[The pulled otter is manufactured by having the external or long hair pulled or stripped off, leaving the soft, fine wool or down underneath; it is then dyed.]

93. Group of dyed lynx, see No. 8.

- 94. " penguin (*Spheniscus aptenodytes*).
- 95. " grebe (*Podiceps cristata*).

[The grebe is an aquatic bird, inhabiting most of the large lakes in Europe. The choicest specimens are from Geneva, Italy, and Holland. The feathers are of rich white, having the appearance of polished silver, the plumage on the outer edge of the skin being a rich dark brown; it is used by ladies, and forms a beautiful article of dress; and is worn as trimmings for the trains of court and drawing-room dresses, for muffs, cuffs, boas, &c. It is very durable; the exquisite smoothness of the feathers prevents its soiling with wear.]

- 96. Specimen of swan feathers.
- 97. " goose feathers.
- 98. " eider down.

[The bird from which the down is taken is found in large numbers in Iceland, Norway, Sweden, &c., its colour is dark grey, and its elasticity, lightness, and resistance to wet, are prominent amongst its other advantages; it is used for the inside stuffing of muffs. On the Continent, the well-known eider-down quilts are largely used.]

99—115. Suits of Russia sable ; Hudson's Bay sable ; sable tail; mink; chinchilla.; grebe; sea otter; Siberian squirrel, with tails; kolinski; minever; ermine; moleskin; natural beaver; dyed beaver; seal; swan; goose down.

[The down of the goose is manufactured by being sewn on textile fabrics. It is a specimen of Irish industry, and has been patronised and sold in England extensively for the benefit of the Irish female poor, by whom it has been made up. The price, compared with the true swans-down, is very moderate. Being sewn upon cloth, it can be washed.]

116. Suit of English silver-grey rabbit; presented by Her Grace the Duchess of St. Albans.

117. Suit of black monkey.

118—140. Fur seal pardessus, dyed; paletot; paletot, trimmed sable; paletot, trimmed mink; paletot, trimmed minever; paletot, trimmed grebe; cloak, lined and trimmed ermine; child's ermine paletot; child's seal paletot, trimmed minever; child's seal paletot, trimmed mink; Polish envelope; child's paletot; child's jacket; gentleman's coat; young gentleman's coat; waistcoat, double-breasted; waistcoat, single-breasted; lady's bonnet; gentleman's stock; lady's hood; gentleman's coat, natural colour; waistcoat, single-breasted, natural colour; waistcoat, double-breasted, natural colour.

141. Tartar foal-skin, lady's pardessus; new design.

142. " gentleman's coat "

143. " waistcoat "

144. Mink lady's pardessus.

145—149. Gentleman's coat, lined fur seal; lined sable, throat or gill; lined genet; lined genet; lined North American grey fox.

150. Gentleman's shube, lined racoon.

151. " lined black bear.

152. Gentleman's coat, lined and quilted eider down.

153. Fur gloves, ladies' and gentlemen's.

154. Fur boots and shoes, ladies' and gentlemen's.

155. Fur travelling caps, ladies' and gentlemen's.

156. Fur coverings for open carriages and sleigh purposes.

156A. Buffalo robes or skins.

[The buffalo is killed in immense numbers by the North American Indians, solely for the tongue, the skin, and

the bosses; they have a peculiar method of dressing the skin with the brains of the animal, in which state it is always imported. It has of late years been much used in Europe.]

157. Carriage wrappers:—North American grey fox, various, outside of waterproof cloth.

158. Carriage wrappers:—Black African monkey, outside of waterproof cloth.

159. Carriage wrappers:—African antelope, outside of waterproof cloth.

160. Carriage wrappers:—North American black bear, outside of waterproof cloth.

161. Carriage wrappers:—Foreign and English cat, various, outside of waterproof cloth.

162. Carriage wrappers:—Silver-grey English rabbit skin. The skins presented by the Duchess of St. Albans.

163. Cloth travelling bag, lined and trimmed bear

164. " lined grey fox.

165. Fur table-covers, various.

166. Cigar-cases, mounted in fur.

167. Silver seal game bag.

168. Fancy chair, covered with silver seal.

169. " covered with silver seal.

170. " covered leopard.

171. " covered natural fur seal.

172. Library chair, covered zebra.

173. " covered zebra.

174. North American fox foot ottomans, mounted on black bear.

175. North American fox, mounted as ornamental mats, rugs, &c.

176. Foot muffs, various.

177. Cloak and coat linings, various.

178. Ladies' needlework, mounted in fur; unique.

179. Models of muffs, various.

180. Rein-deer hoofs and mitts, specimen of Canadian Indian embroidery and fur; presented by the Marquis of Worcester.

181. Eider-down quilt.

182. Swan-down puffs.

Specimens of natural history, set up to illustrate the various skins.

183. Lions, furnished for the Exhibition by Mr. Meyer.

184. Group of leopards, by Zoological Society.

185. " ocelots, by Zoological Society.

186. Arctic wolf, by Hudson's Bay Company.

187. Arctic blue fox, by Hudson's Bay Company.

188. Group of beavers, by Hudson's Bay Company.

189. " otters, by the Marquis of Worcester.

190. " polecats, by Earl Nelson.

191. " fox, by Marquis of Worcester.

192. " grebes, by Marquis of Worcester.

193. " musquash, by Hudson's Bay Company.

194. Ornithorhyncus, by Mr. Ellis.

195. " lynx, by Hudson's Bay Company.

196. Javanese musk deer.

197. Group of antelopes, by Zoological Society.

198. " perewaizka, by Zoological Society.

199. White stone martin, by Mr. George Smith.

200. White Siberian squirrel, by Mr. George Smith.

201. European hare and Polar white ditto.

202. Head and fore paws of royal tiger, of great size and beauty.

203. Model of Peeress, in her coronation robes of estate.

204. Ladies' cloaks, lined squirrel lock, trimmed with grey Siberian squirrel with tails.

205. Lady's walking paletot, lined fur.

206. Lady's travelling cloak, lined fur.

207. Muff and boa, made of the down from the feathers of the bird called the egret. The costly nature of the material is such, and its rarity so great, that three other sets only have been made during the last century, the possessors of which are imperial and royal personages. Manufactured by Mons. Ray, of Paris, for the exhibitors.

208. Group of Russian sables.

209. English badger, by the Marquis of Worcester.
210. Group of heads, rare specimens from Central Africa, by Captain Bates.
- 302 POLAND, SON, & MEREDITH, 52 *Bread Street, Cheapside*—Designers and Manufacturers.
Leopard hearth-rugs.
Rugs: miniature tigress, with two cubs.
- 303 SAMSON, PHILIP, 1 *Little Knight Rider Street, St. Paul's Churchyard*—Manufacturer.
Fur articles, embroidered in chenille, &c., in floral and figured designs. Fur collar. Fur and imitation-fur elastic cuffs.
- 304 MEYER, S. & M., *Bow Lane, City*—Manufacturers.
Dressed, dyed, pulled, and sheared English rabbit-skins; riding boas, muffs, cuffs, cardinals, round boas, caps, and gloves.
- 305 ELLIS, GEORGE, 23 *Fore Street*—Designer and Manufacturer.
Boas, victorines, muffs, and other articles in fur and velvet.
- 306 DRAKE, R., 25 *Piccadilly*—Manufacturer.
Russia sable, spotted ermine, and grebe muffs.
Pieces of the spotted ermine lining of the Queen's coronation robes; also of King William the Fourth's, and of King George the Fourth's.
Astracan lamb's skin: the paws are used for spotting the ermine lining of coronation robes.
- 307 CLARKE, ROBERT, & SONS, 157 *Cheapside*—Manufacturers.
Manufactured furs of ermine and mink; cardinals, muffs, boas, cuffs, and gauntlets; the same of musquash, natural and dyed.
- 308 CALLOW, T., & SON, 8 *Park Lane*—Inventors and Manufacturers.
Riding whips, of clarified rhinoceros hide, in various colours.
Riding and driving whips, with the handle of hippopotamus leather, enamelled green.
The rhinoceros whips and the hippopotamus leather are stated to be invented and made by the exhibitors.
- 309 INCE, J., 75 *Oxford Street*—Manufacturer.
Royal tiger-skin rug, mounted with black bear.
Two coronation ermine muffs, constructed upon a new and improved principle. One is inflated with air, which can be immediately discharged, and the muff compressed to the most portable size, when not required for use, the other folded up.
- 310 LUTGE & PARSONS, *King Edward Street*—Manufacturers.
Registered Princess Royal, in Russia sable, American sable, mink, ermine, minever, chinchilla, squirrel, and seal boas.
A large rug, with a very rare skin in the centre, between a leopard and tiger, surrounded by the Royal Arms, H.R.H. Prince Albert's Arms, and H.R.H. Prince of Wales's Feathers; all worked in furs.
- 310A SMITH, GEORGE, & SONS, 10 *Watling Street*—Manufacturers.
Muffs, cardinals, flat boas, riding boas, cuffs, &c., in a variety of furs, including Russian sable, Hudson's Bay and Canadian martin or sable, sable tail, Russian squirrel, Siberian squirrel, chinchilla, and fitch.
Specimens of the same, dyed.
- 311 DICK, A., 35 *Georges Street, Edinburgh*—Manufacturer.
Fur hearth-rug, worked with upwards of 2,500 pieces from different furs, comprising martin, sable, British
- sable, real ermine, imitation ermine, squirrel, kolinsky, &c.
- 312 GARNER, D., 41 *Finnsbury Market*—Manufacturer and Designer.
Registered portable boot-tree, adapted for button-boots, shoes, &c., and contains brushes, blacking, boot-hooks, boot-powder, &c. Boot and shoe lasts.
- 313 HIDDEN, T., 88 *London Road, Southwark*—Manufacturer.
Leather buttons, with flexible shanks, on an improved principle, for boots, shoes, and wearing apparel.
New leather beads of various colours.
- 314 CORRY, J. & J., *Queen Camel South, near Sherbourne*—Producers.
Specimens of kid and lamb leather, carried.
- 315 CASE, CHARLES, 45 *Wood Street, Cheapside*—Manufacturer.
Ladies' and gentlemen's riding whips of black and white twisted whalebone.
Gentlemen's walking-sticks, of black knotted whalebone.
Gig whips, knotted and plain, with silver mounting.
- 316 MARSDEN, C., *Waterloo House, Kingsland Road*—Inventor.
Patent ventilating boots and shoes.
- 317 LEATHART, CHARLES, 15 *John Street, Waterloo Road*—Inventor.
Liquid hair dye. The effect of the dye illustrated by a wig, in a case, containing four shades of hair.
- 318 TAYLOR, T., *Dublin*—Inventor.
Specimen of soluble leather.
- 319 PHIPPS, W. D., *Cadogan House, Sloane Street*—Inventor.
The Eupadian registered elastic spring boots.
- 320 HADLEY, R., 72 *High Street, Worcester*—Improver and Manufacturer.
Ladies' ornamental hair, in fronts, bands, curls, and plaits.
- 321 MANTEL, W., *Bedford*—Designer and Manufacturer.
Three improved wigs, and lady's head-dress.
- 322 CARR, WILLIAM, 10 *Hatton Wall*—Manufacturer.
Improved premier blacking.
- 323 NEWCOME, J., *Swinegate, Grantham*—Inventor.
Shoes made from a new material.
- 323A ADCOCK & Co., 3 *Princes Street, Cavendish Square*—Producers.
Choice collection of dyed feathers.
(*Main Avenue West.*)
- 324 NELSON, J., *Holloway*—Inventor.
Boots warranted to wear in the centre of the sole.
- 325 CARRON, W., *Birmingham*—Inventor.
Patent clogs.
- 326 ESSEX, J., 1 *Charterhouse Lane, St. John Street*—Manufacturer.
Fancy lamb and sheep-skin wool rugs for hearths, carriages, &c.
Carriage feet muffs; and travelling and invalid wool boots.
- 327 ALLIN, W. S., 1 *Dorset Mews, East Baker Street*—Producer.
Pair of boots.

328 LUTGE & Co., *King Edward Street*—Manufacturers.

Royal boas in Russian and American sable, mink, ermine, minever, seal, and chinchilla.

Large rug with rare skin in centre, surrounded by the royal and other arms.

329 BOWER, M., *Birmingham*—Manufacturer.

Patent screen saddle, or gig-pad, by which a horse's loins can be covered or uncovered while standing, by a pair of reins which lay over the dash-board.

330 LAYCOCK, S., & SONS, *Porto Bello Place and Mill Sands, Sheffield*—Manufacturers.

Specimens of damask and striped hair-seating, various colours; plain satin and linen warp, black, and cotton warp, black.

Russian horse-hair, white; South American, black
Materials used in the manufacture of hair seating.

In these specimens a variety of damask patterns or designs are introduced, by the application of the Jacquard loom, and also a diversity of colours.

[Formerly the warps for hair-seating were made exclusively of linen yarn, but of late years cotton has been extensively used, chiefly for export to the United States, on account of its softness, as it produces cloth of a more pliable texture, and of smoother and more even surface, and considered better suited to the purposes of tufting than the fabric made from linen yarn.

Horse-hair suitable for making coloured seatings must

be pure white; it is afterwards dyed of various colours, and of this there is only a limited supply. Some difficulty might consequently arise in procuring the raw material.

Hair-seating is woven by hand, every hair being introduced singly. It differs in this respect from most other woven fabrics, in which there is a uniform and continuous supply of material, thereby permitting the application of steam-power. In hair-seating, the weft being in detached pieces, it has been found that power-looms cannot be advantageously employed.]

(Placed in Class 11.)

331 McDUGALL, D., *Inverness*—Producer.

Highland stalking boots; and dress shoes.

332 BEVINGTON & MORRIS, *King William Street, City*—Manufacturers.

Sheep-wool mats and Angola goat-mats, in great variety, plain and fancy, for hearth-rugs, carriages, and doors, &c. A variety of furs in cardinals, muffs, boas, riding-boas, and cuffs, both natural and dyed.

334 WORSLEY, JOSH., *31 Sunderland Street, Macclesfield*.

A pair of shooting-boots of extraordinary manufacture.

335 NEVILL, Major—*United Service Club*—Proprietor.

A jacket made from the skin of a stag shot at Eridge Park.



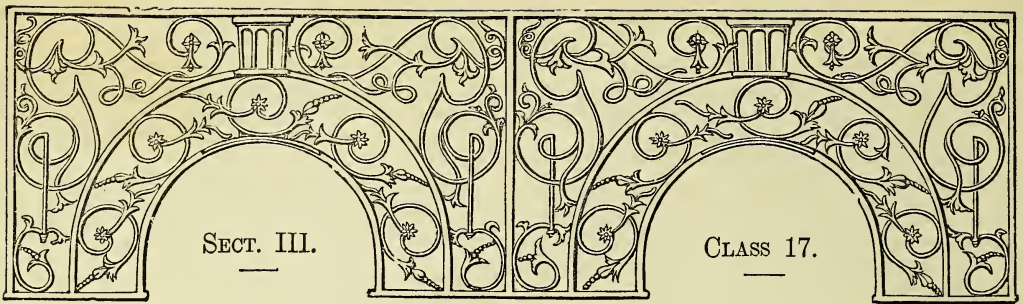

PAPER, PRINTING, AND BOOKBINDING.

INTRODUCTION.

PAPER of every description, printing and bookbinding, with the miscellaneous articles connected with correspondence, and useful and ornamental stationery, form the subjects of the present Class. The manufacture of these articles—ministering not to the personal or domestic wants of mankind, so much as to their intellectual requirements—is one the annual increase of which is coextensive with the diffusion of knowledge. And it may be truly said, that, morally and intellectually considered, the present Class relates to a species of industry exercising indirectly a more extensive influence over social economy than any of those into which this Exhibition has been subdivided. Books, it has been said, carry the productions of the human mind over the whole world, and may be truly called the raw materials of every kind of science and art, and of all social improvement. The Sub-Classes are as follows:—A. Paper in the raw state as it leaves the mill, such as Brown Paper, Millboards, Printing, Writing, and Drawing Papers, &c.; B. Articles of Stationery, as Envelopes, Lace Papers, Fancy Papers, Ornamented and Glazed Papers, Sealing-wax, Wafers, Inks of all kinds, &c.; C. Pasteboards, Cards, &c.; D. Paper and Scafeboard Boxes, Cartonnerie, &c.; E. Printing, not including printing as a fine art, and Printing Inks and Varnishes; Bookbinding in cloth, velvet, vellum, &c.; Fancy Books, Portfolios, Desks, &c.

The position occupied in the Building is in the North side of the Western Main Avenue; and the Areas included are F. 27 to 29, G. H. I. J. 26 and 27. Rather more than 200 exhibitors appear to represent this Class in its various branches of industry.

The localities from whence the articles exhibited have been sent are much less restricted than in preceding Classes. Many of the exhibitors appear in the capacity of producers of small articles for fancy purposes; and as these are obviously capable of being made at home, requiring taste and minute skill rather than mechanical power for their manufacture, the places from which they have been forwarded for exhibition have not the special interest attaching to great producing towns or cities, where thousands of machines and operatives are all occupied in one department of manufacture. From the metropolis, however, where a large demand for such articles exists, the great proportion of them are derived. London also represents most largely the enormous printing resources of this country. But of these, as specimens only of single works can appear, but a faint idea can be gained from the examples exhibited. In one of the greatest establishments of the Metropolis twenty machines are constantly occupied, each of which is capable of throwing off from 3,000 to 4,000 impressions per hour, and in addition a large number of printing machines for fine work are employed. These great printing establishments resemble very closely the large manufactories of other districts, only their organization differs with the peculiar nature of the manufacture, if the mechanical production of printed books may be so termed.

Paper, more legitimately reckoned among manufactures than printing, has a certain limitation to districts for particular kinds. Considerably more is made in England than in Scotland or Ireland. Kent is celebrated for its fine writing and drawing papers. From Lancashire, Berkshire, Hereford, and Derbyshire, papers of various kinds are supplied. The quantity of paper annually manufactured in England two years ago amounted to 132,132,657 lbs.; in 1834, it was little more than half that quantity. In 1839, it was estimated that the quantity used, if equally divided among the population, would have been about three pounds and three-quarters for each individual.

A variety of mechanical improvements, both in the production of paper and in that of printed books, has been introduced of late. In the manufacture of paper the substitution of machine for hand labour has been attended with the most momentous results. In 1801, the price of a ream of paper of a particular description was 36s.; in 1843, the same paper could be purchased for rather less than half this sum. In 1721, it is estimated that 300,000 reams of paper were annually produced in Great Britain. In 1841, 97,105,550 lbs. were made in the United Kingdom: the total annual value is at present not far short of two millions sterling. Much of the increase thus exhibited is due to the introduction of mechanical power; but the fiscal regulations upon this branch of industry, which were formerly extremely oppressive, having been removed to some extent, another cause of increased production and consumption is thus superadded. Paper may, however, be likewise regarded as a chemical product, as it is certain that a large amount of chemical knowledge has been successfully combined with mechanical skill in its preparation. By the co-operative forces of chemical processes and mechanical instruments, the most refuse matter thus becomes converted into a white and pure material. As an evidence of the enormous length of paper produced by mechanical power, two great rolls are exhibited—one is 750 yards long, the other 2,500 yards in length.

The application of improved machinery to printing is also of recent date, and has been attended with results of great moment. Progress is still made in this direction, and in a preceding Class will be found a more detailed account of the introduction of an entirely new principle in printing (the vertical), the application of

which for the rapid multiplication of newspapers is extending. By this arrangement, the vertical, the power of production is only limited by the size of the machine.

Among many interesting specimens of typography, those which exhibit the production of books in other tongues, by type cast in England, will attract notice. The Holy Scriptures are exhibited in one hundred and fifty different languages—a noble evidence of the highest application of industry to the enlightenment and welfare of mankind. Beautiful specimens of the bookbinder's art are likewise shown.

An envelope-folding machine, placed at the side of the Main Avenue, is a striking instance of the successful application of mechanical movements to the performance of the most delicate and complicated actions. By this machine, which would in strictness appear to belong to a preceding Class, the movements of the hand of the folder are not only exactly imitated, but the result is more accurate and certain, and the power of production is very largely increased.

The peculiar interest which attaches to the objects in this Class, as the most powerful agents in the social and intellectual improvement of man, cannot fail to be awakened by the most casual inspection. Paper, printing, and bookbinding, are, however, only the raw material, the application and reproduction of which is dependent upon the powers of the mind, not on those of matter.—R. E.

1 ACKERMANN & Co., 96 Strand—Producers.

Ornamental colour box, containing 100 cakes of colours and requisites, enamelled in gold and colours.

Imperial scrap books and other articles of stationery and ornament, including envelope cases, seaweeds, pole-screens, &c.

Odoriferous lighters, for conveying flame to candles, lamps, tapers, cigars, &c., and by an ambrosial and sanitary perfume, refreshing the atmosphere.

Specimens of water-colours on alabaster, by E. Sant, Paris.

4 HUGHES, EDWARD, Greenwich Hospital Schools—Designer.

An improved map of the British islands, on a scale of $\frac{1}{550,000}$ of the natural size, exhibiting their physical features and political divisions; also their pastoral, agricultural, mining, and manufacturing districts and fishing stations, with the population, and industrial occupation of the inhabitants.

Map of Palestine and adjacent countries, exhibiting their physical features, and illustrating the political geography of scripture narrative.

5 REMNANT, EDMONDS, & REMNANT, Lovell's Court, Paternoster Row—Manufacturers.

Books bound in various styles of Morocco, Russia, calf, roan, sheep, and cloth.

7 HAWTHORNE, JAMES, 77 Charrington Street, St. Pancras—Manufacturer.

An assortment of inks for writing, copying, marking on linen, &c., with specimens of their effect.

Specimens of nut-galls, broken and whole (*Quercus infectoria*), and of the fruit of the *Terminalia Chebula*, from Bengal.

8 EVANS, JOSEPH S., 64 Berwick St., Soho—Manufacturer.

Specimens of bookbinding in vellum, illuminated, &c. Bookbinding in leather stained by hand, in imitation of various woods, and washable.

Improved binding for account books.

9 FAIRBAIRN, ROBT., 37 Great Cambridge St., Hackney Rd.—Manufacturer.

Specimens of wood type for printing, &c.

10 FISHER, JABEZ HENRY, New North Road, Hoxton—Inventor.

Specimen of a bank note for the prevention of forgery, printed in a chemical water-colour, from a steel-plate engraving, the process producing two colours at one operation; the lettering in black, and the ornamental background in a neutral tint. Any signature upon this note cannot be erased without changing the colour. The letter-press on the note cannot be transferred or copied, and is printed on a prepared paper.

11 GALLARD, W., 30 Lisson Grove—Designer.

Portable composing frame, to provide temporary accommodation for cases at the imposing stone during correction of proofs, or for extra cases near the compositor's

frame for work, that has a mixture of italic or other letter with that of the text.

12 GILL, THOS. DYKE, 27 Charlotte Street, Fitzroy Square—Inventor.

Postage stamp expedient, for saving time, &c.

14 BINNS & GOODWIN, Bath—Publishers.

Natural illustrations of the British grasses; illustrated with sixty-two real specimens.

17 HIDER, ELIZABETH, 15 Manor Place, King's Road, Chelsea—Designer and Manufacturer.

Fancy floral paper for valentines.

18 DEAN & SON, 35 Threadneedle Street—Producers.

Ornamented and illustrated letter and note paper.

19 STIDOLPH, —, 2 New Bond Street, Bath—Inventor.

The chiragon, a hand guide for blind and tremulous writers. Its advantages are straightness, equidistance, simplicity, and freedom.

20 HUGHES, G. A., 9 Mount Row, Westminster Road—Inventor.

Machine for enabling persons born blind to write in raised characters without using types. This system is well adapted for writing French, as all the accents can be faithfully represented.

Machine to write with pen or pencil in skeleton Roman capitals, which can be read by blind persons as well as by those gifted with sight.

Machine to cast accounts and make general arithmetical calculations by tangible characters.

Machine to copy and compose music on paper. The inventor is himself wholly blind.

Stenographical treatise.—Embossed.

First-class book and writing lessons.—Embossed.

Musical notation; reading alphabet, with examples.—Embossed.

21 HYDE & Co., 61 Fleet Street—Manufacturers.

Sealing-wax, in combination with Rider's new mode of taking impressions from stone, metal, and composition intaglios.

Solid India sealing-wax, made hard expressly for use in hot climates.

22 KING, THOMAS & J. H., 4 Bartlett's Buildings, Holborn Hill—Designers and Manufacturers.

Specimen of a new type-music, in which the various pieces are combined on an improved principle, and very few kerned types are required; accurate in its composition, and equally adapted for simple or complex music. The same combination, with a new form of note. Series of chant-music. Original design of a series of letters, called arabesques.

[There are two kinds of music type in use; in one, the complete note is cast in one solid piece, and in the other (the kerned description) it is made up of five different

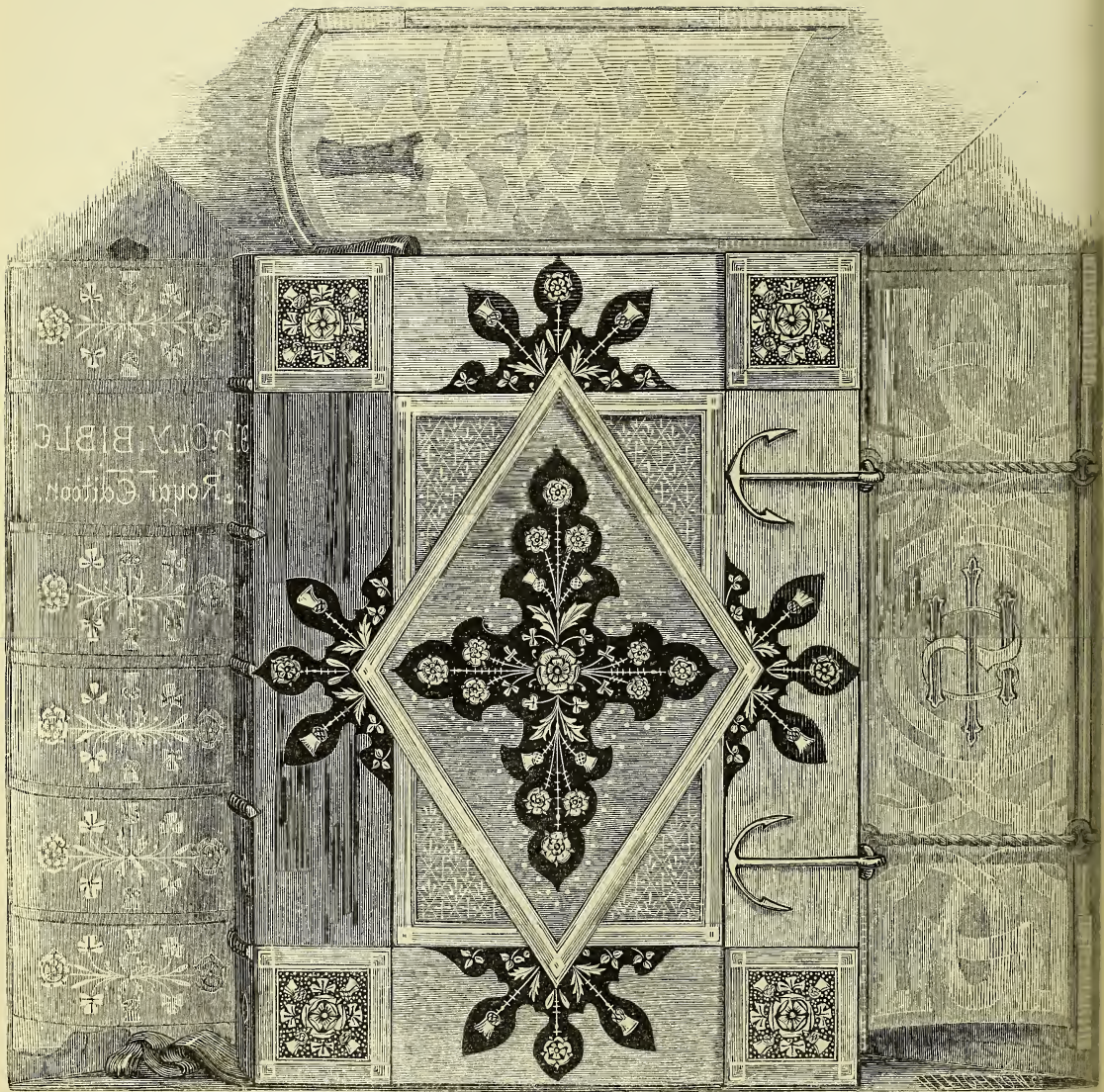

44. ROYAL BIBLE. MESSRS. LEIGHTON. THE TOP, BACK, AND FRONT ARE SEEN AS REFLECTED IN A MIRROR.

26 **MACOMIE, ALEXANDER, & Co., 6 Percy St., Bedford Sq.**
—Manufacturers.

Specimens of pulpit, family Bible, and other binding, and table clock case.

Gottfried Weber's "Theory of Musical Composition," 2 vols., 8vo, edited by John Bishop; exhibited as a specimen of bookbinding, and of letter-press and music printing by moveable types; also an illustration of the several industrial arts employed in its production.

27 **MANSELL, JOSEPH, 35 Red Lion Square**—Designer, Manufacturer, and Proprietor.

Specimens of ornaments used for decorating linens, muslins, damasks, brown Hollands, woollen cloths, &c. Embossed and perforated Bristol boards for drawings, and illuminated for show cards, &c. Paper embossed, and in imitation of lace, &c., and other ornamental stationery. Envelopes and cards, embossed in silver.

29 **MARTIN, J.**—Patentee.

Waterproof paper, rendered so by a newly-invented kind of size. The paper manufactured by Mr. Pearson, Branthwaite, Cumberland.

31 **PARSONS, FLETCHER, & Co., 22 Bread Street**—Manufacturers.

Printers' inks.—Black, for wood-cuts, book-work, newspapers, and posting bills. Coloured, for printing placards, &c.

32 **PENNY, H., 11 Old Bailey**—Manufacturer.

Metallic pocket-books, with pencils composed of various metal. The writing cannot be obliterated by the friction of the leaves, or by the use of India-rubber.

33 **PINCHES & Co., 27 Oxendon Street**—Manufacturers.

Illuminated note paper, and envelopes of various heraldic devices. Specimens of stamping in relief on envelopes and paper; of stamping in surface or cameo; and of the registered purse envelope.

W. Smith's improved stamping press.

Medal dies, with the collars and tools used in the manufacture of medals, including a matrix and punch.

Button dies, and military ornament dies.

Various impressions from dies and seals.

Registered chessmen, in Jennens & Bettridge's papier maché, gold and silver. Alphabet, in papier maché and metal.

34 **ROYSTON & BROWN, 40 and 41 Old Broad Street**—Manufacturers.

Specimens of ledgers, journals, and cash books, in various bindings. A book of prepared copying paper, bound in morocco, with index, and paging; made with lock and key, for a copying press. A book of short guards, made of adhesive paper, for securing the copies of letters, or other documents.

35 **SAPSFORD, NEWMAN, 17 Kirby Street, Hatton Garden**—Manufacturer.

Specimen of book-binding.

36 **SAUNDERS, T. H., Queenhithe, and Dartford, Kent**—Manufacturer.

Strong parchment paper for government loans, shares in banks, railway mines, and public companies; also adapted for envelopes for foreign despatches, and a variety of other purposes.

Bank-note papers, plain and coloured, of strong texture, with a variety of water-marks, to prevent fraud.

Specimens of a new method of making papers with water-marks of an elaborate and complicated design.

White and coloured safety paper for bankers' cheques, letters of credit, &c., detecting the removal of writing by any chemical agent.

Glass transparency to show the water-marks in paper.

37 **SAUNDERSON, C., Kilburn Lodge, Kilburn, Middlesex**—Proprietor.

Map of Ireland, engraved on copper, by John Dower, showing the provinces, counties, cities, county and market towns, with distances from Dublin, &c. With two illustrations from drawings made expressly for the map, and engraved upon steel, by J. C. Armitage; contained in a wooden map-case, carved in ivy and shamrock leaf, with a centre shield, by George Howton.

The impressions from the steel plates are taken upon China paper and transferred to the spaces left on the map for their reception.

38 **SCHLESINGER & Co., 8 Old Jewry**—Inventors.

Registered metallic memorandum books, with newly invented flexible backs, in morocco, russia, and other materials, to admit many documents. Variety of portfolios, music-folios, wallets, and pocket-books, of the same construction. Patent letter-clips. Registered parallel rulers, by which paper is ruled either with ink or pencil, in a shorter time than with common rulers.

40 **SILVERLOCK, H., 3 Wardrobe Terrace, Doctors' Commons**—Designer.

Specimen of letter-press printing from stereotype plates of medallion engraving and machining, intended to combine the effect of copper-plate engraving with the cheapness and rapidity of letter-press printing.

41 **SMITH, JEREMIAH, 42 Rathbone Place**—Inventor and Manufacturer.

Adhesive envelopes (requiring neither wax nor wafer), and note and letter papers, embossed with emblazoned arms, crests, mottoes, initials, &c.

Dowse's patent tracing and writing cloth, for engineers, surveyors, architects, and others.

PAPERS.

[In the interesting collection of papers in the Exhibition, from various paper-mills, there are groups whose degrees of excellence must be estimated by very different standards; as, for instance, the brown wrapping and the fine hand-made drawing papers, the sugar and the fine printing papers, the bibulous plate paper for engravers' use, and the hard sized writing papers. Collectively it exhibits, at one view, the various qualities which are sought for by English consumers, and which, in many respects, differ from those required by our Continental neighbours; as an example, may be quoted the substantial English writing papers and the thin post papers of France and Belgium, whose different qualities arise from the difference of postal regulations in those countries.]

The system of producing paper in continuous lengths by machinery was first introduced by Messrs. Fourdrinier into this country, they having purchased the patent right of Mr. Gamble, who, in 1804, obtained permission from the French Government to bring to England a model of a machine, invented in 1799, by Louis Robert, who was then employed in the paper works of Essonne. This machine of Mr. Roberts was essentially imperfect, but it was brought to a state of great perfection for Messrs. Fourdrinier, by the ingenuity of Mr. Bryan Donkin; upon this has been founded the various descriptions of paper-making machines which have since that time been introduced. They consist essentially of contrivances by which the paper pulp is made to flow on the surface of an endless wire web; a rapid up and down motion being given to it for the purpose of shaking the water out of the pulp, and thus producing a complete interweaving of the textile filaments. The continuous roll of paper thus formed is turned off upon a second solid cylinder, covered with felt, upon which it is condensed by a third, and eventually delivered to drying rollers.

Swedish filtering paper is made with pure water, and is more free from impurity than any other; this is, in fact, pure cellulose, and yields only half a per cent. of ash on incineration. Laid papers are those with a ribbed surface; wove papers those with a uniform surface. Blue papers, under the microscope, no longer appear of uniform tint, on the contrary the particles of colour are seen widely separated.

In reference to the pulp in its various stages of preparation, it may be stated, that numerous attempts have been made to employ other fibres, besides those of cotton and flax, in the manufacture of paper; for instance, straw, hop-bine, grasses, refuse of sugar cane, wood shavings, &c.; and, although paper has been produced from these materials, yet, commercially, the attempts have been unsuccessful.

Subjoined are the principal sizes of writing paper in English inches, and in French centimetres, to the nearest millimetre, or tenth of a centimetre.

	Inches.	Centimetres.
Double elephant	40 × 26 $\frac{3}{4}$	101·6 × 067·9
Atlas . . .	34 × 26	086·4 × 066·0
Colombier . .	34 $\frac{1}{2}$ × 23 $\frac{1}{2}$	087·6 × 059·7
Imperial . .	30 × 22	076·2 × 055·9
Elephant . .	28 × 23	071·1 × 058·4
Super royal .	27 × 19	068·6 × 048·3
Royal . . .	24 × 19	061·0 × 048·3
Medium . . .	22 × 17 $\frac{1}{2}$	055·9 × 044·4
Demy . . .	20 × 15 $\frac{1}{2}$	050·8 × 039·4
Large post . .	21 × 16 $\frac{3}{4}$	053·3 × 042·5
Small post . .	19 × 15 $\frac{1}{2}$	048·3 × 039·4
Foolscap . . .	16 $\frac{1}{2}$ × 13 $\frac{1}{4}$	041·9 × 033·7

W. D. L. R. and R. H.]

42 SPICER BROTHERS, *New Bridge Street, London*—
Wholesale and Export Stationers.

Writing Papers.

Large cream laid post, various thicknesses.
Large yellow wove post, various thicknesses.
Large blue laid post, various thicknesses.
Large blue wove post, various thicknesses.
Small cream laid post, various thicknesses.
Small cream wove post, various thicknesses.
Small yellow wove post, various thicknesses.
Small blue laid post, various thicknesses.
Medium wove post, various thicknesses.
Large wove bank post, various thicknesses.

Paper for Account Books.

Superfine laid imperial, various thicknesses.
Superfine laid royal, various thicknesses.
Superfine laid demy, various thicknesses.
Superfine laid foolscap, various thicknesses.
Superfine wove foolscap, various thicknesses.

Printing Papers.

Superfine demy, various thicknesses.
Superfine royal, various thicknesses.
Superfine double demy, various thicknesses.
Superfine double foolscap, various thicknesses.
Superfine double crown, various thicknesses.
These are used for ordinary printing purposes, from the most costly folio, down to the cheapest tract.
Fine laid news, various thicknesses.
Fine wove news, various thicknesses.
These are exhibited of different sizes, as well as thicknesses, for newspaper purposes.

Papers for various purposes.

Fine long elephant, 23 inches wide, in a sheet of 750 yards in length.

Fine double elephant, 46 inches wide, in one sheet of 2,500 yards in length, for paper-staining, decorations, and artistical purposes.

Long elephant, 23 inches wide, in sheets of 12 yards, for paper-hangings, of various qualities.

Brown papers of various sizes and thicknesses, made from pure rope, and especially intended for packing purposes.

A sheet of brown paper, 93 inches wide, 420 feet long.

[The introduction of machinery into the manufacture of paper alone could have produced a continuous sheet of the immense length and breadth described. In the processes by which machine-paper is made, there appears no more difficulty, in consequence of the continuity of the manufacture, in making a sheet of an indefinite length, than in making one of a few feet; and if a supply of pulp could be furnished, the machine might produce a continuous sheet sufficiently long to encircle the world.]

Buckinghamshire and Scotch millboards, for bookbinding, portfolios, trays, waiters, or japanned goods, trunks, steam-pipe joints, boxes, cases, gun-wadding, &c.

42A JOYNSON, WILLIAM, *St. Mary Cray*—Manufacturer.

Extra Superfine Writing Papers.

Large blue wove post, 22 lbs. per ream.
Large blue wove post, 19 lbs. per ream.
Large blue wove post, 17 lbs. per ream.
Large blue laid post, 22 lbs. per ream.
Large blue laid post, 19 lbs. per ream.
Large bank post, 5 $\frac{1}{2}$ lbs. per ream.
Large bank post, 7 lbs. per ream.
Large bank post, 10 lbs. per ream.
Medium bank post, 8 lbs. per ream.
Large cream laid post, 19 lbs. per ream.
Large cream laid post, 22 lbs. per ream.
Small cream laid post, 17 lbs. per ream.
Small cream laid post, 20 lbs. per ream.
Small cream laid post, 24 lbs. per ream.
Small cream laid post, 25 lbs. per ream.
Small blue laid post, 17 lbs. per ream.
Small blue laid post, 19 lbs. per ream.
Blue laid foolscap, 15 lbs. per ream.
Cream laid foolscap, 15 lbs. per ream.

43 TARRANT, ALFRED, *190 High Holborn*—Manufacturer.
Specimens of bookbinding.

44 THOMAS & SONS, *20 Cornhill*—Manufacturers.

Ledgers, atlas folio, and private ledgers in various sizes and bindings.

45 TURNBULL, J. L. & J., *Holywell Mount, Shoreditch*—Manufacturers.

London drawing-boards, one composed of three sheets of paper, and one of ten, hand-made. Royal drawing boards, rough and smooth surface. Coloured crayon-boards, royal size, rough and smooth surface. Direction cards.

46 WATERLOW & SONS, *66 London Wall*—Manufacturers.

Complete set of account books, with patent backs. Numerous articles of general stationery.

47 WEDGWOOD, RALPH, *84 Lombard St.*—Manufacturer.

Patent manifold writer, for copying letters, invoices, drawings, plans, &c.

Improved noctograph, with barred frame. Royal desk noctograph. By these inventions, persons who have lost their sight are enabled to correspond with their friends with facility, without other aid. Registered desk clip.

48 WESTLEY, JOSIAH, *Playhouse Yard, Blackfriars*—Manufacturer.

Specimens of antique and modern bookbinding, in morocco, russia, calf, and cloth; also appropriate designs, produced by hand and machine, with block decorations by Luke Limner, Esq. One of these specimens of antique binding is exhibited in the adjoining Plate 85.

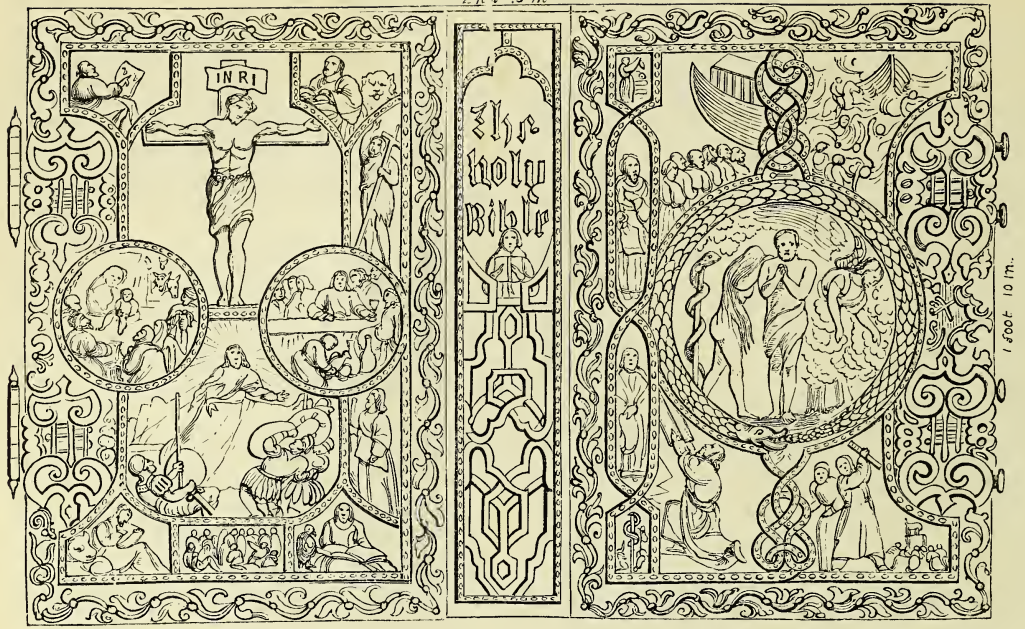

SPECIMEN OF ANTIQUE BINDING, IN CARVED OAK. J. GOULD.

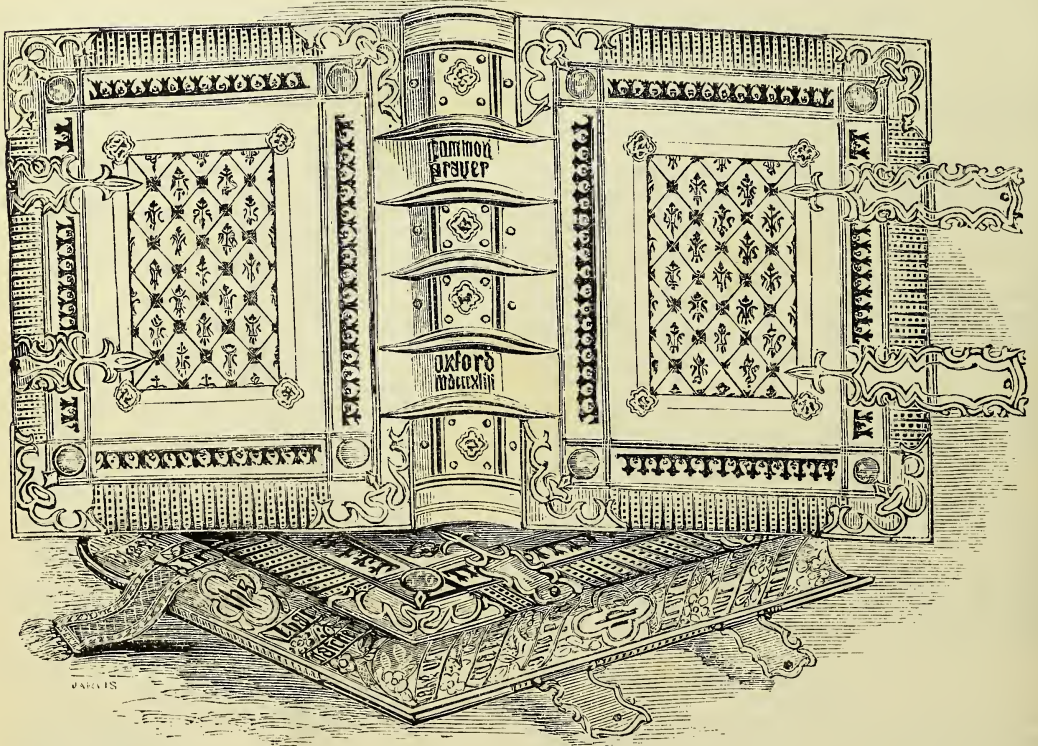

- 49 WHITAKER, ROBERT, 13 and 14 *Little Britain*—
Manufacturer.
Playing-cards, the backs enamelled and ornamented in gold and colours.
- 51 WHITEMAN, F. J., 19 *Little Queen Street, Holborn*—
Manufacturer.
Specimens of improved perforated plates, for marking linen, and other articles with indelible ink.
Specimens of marking on satin, with permanent ink. The plates are engraved and prepared by a peculiar process, and will not decompose any of the materials that may be used with them. (*In North Gallery, F. 18.*)
- 52 WIDNALL, GEORGE FREDERICK, 6 *Harrow Road, Paddington*—Inventor.
Railway, omnibus, and toll-bar pocket-book and purse.
- 53 WILLIAMS, JOHN, 29 *Bucklersbury*—Manufacturer.
An assortment of ledgers.
- 55 ARLISS & TUCKER, 15 *Frith Street, Soho*—
Inventors and Manufacturers.
Exterior and interior views of the building for the Exhibition of 1851, showing the application of printing to tinfoil and other metallic substances.
- 56 ATKINSON, WILLIAM, *Lamb's Passage, Finsbury*—
Manufacturer.
Specimens of dyed and embossed calico, for bookbinding purposes.
- 59 BATTEN, DAVID, *Clapham Common*—
Manufacturer.
Guard books, and specimens of bookbinding.
- 60 BENNER, Dr. W., B.A. *Cheyne House, Collegiate School, Chelsea*—Inventor.
Complete phonological English alphabet, constructing self-pronouncing words with the proper orthography.
Mechanical syllabicator and model mechanical instructor.
- 61 BINGLEY, MARK, 10 *Lawrence Pountney Lane*—
Inventor and Manufacturer.
Patent headbands for bookbinding, made by machine, in lengths of several yards.
- 62 BONE, WILLIAM, & SON, 76 *Fleet Street*—
Manufacturers.
Specimens of bookbinding in cloth; and in cloth and morocco, showing the present state of the art.
- 63 BOWDEN, G., 1 *Little Queen Street, Holborn*—
Inventor and Manufacturer.
Registered artist's economical desideratum, having, when closed, the appearance of a small, neat, flat case, with a light waterproof, or fancy leather cover; but when opened it will be found to contain an improved seat, with apparatus for holding the "desideratum," and the necessary requisites for an artist, either in sketching, oil painting, or water-colour drawing.
- 64 BRETNALL, THOMAS DAVIS—Manufacturer.
Patent paper cloth, made transparent for tracing maps, plans, engineering and architectural drawings, &c. In rolls of 100 yards long by 40 inches wide, without fold or joint. The same not transparent.
The surface is applied to and incorporated with the cloth during the process of its manufacture.
- 65 CAHN, DAVID, 16 *Wilson Street, Finsbury*—
Manufacturer and Importer.
Vine and ivory blacks, for copper-plate, letter-press, and lithographic printers, dyers, japanners, paper-stainers, and carriers.
- 66 CANDY, T. H., *King's College, Strand*—Inventor and Proprietor.
Map of the globe, intended to illustrate a new method of terrestrial delineation. The peculiarity consists in all the meridians being of the same length, and all the parallels of latitude in their true proportion.
[The above map is drawn upon a modification of that which is termed the conical projection.—J. G.]
- 67 CHURTON, EDWARD, 26 *Holles Street*—Designer.
Specimens of bookbinding; each work ornamented according to the era or the subject of which it treats.
- 68 CLARKE, J., 61 *Frith St., Soho Square*—Manufacturer.
Various specimens of bookbinding.
- 69 CUSSONS & Co., 51 *Bunhill Row*—Manufacturers.
Bookbinders' cloth, dyed, embossed, and finished by the exhibitors.
- 71 CLEMENTS, J., 21 & 22 *Little Pulteney Street, Golden Square*—Inventor.
Material for bookbinding, or other purposes where plain or ornamental surfaces are required.
- 73 COOKE & SONS, 84 *Cannon Street*—Manufacturers.
Coloured, embossed, and transparent sealing-wax, with impressions.
- 74 CRUCHLEY, GEORGE F., 81 *Fleet Street*—Designer.
A large map of England and Wales, consisting of 65 sheets, each 24 by 19 inches, at two miles to the inch (half the scale of the ordinary maps).
Maps of Europe and the world.
Map of London and environs, which illustrates to the extent of six miles round St. Paul's.
- 76 DE LA RUE, THOMAS, & Co., 110 *Bunhill Row*—
Manufacturers and Proprietors.
Envelope-folding machine, invented by Edwin Hill and Warren De la Rue.
[The following is the action of this machine. The feeding-boy places the previously cut blank envelopes on to a small platform, which rises and falls in the rectangular recess formed by the cylindrical axes of the folders (shown open in the engraving); the bearings of the folders serving by their elongation to guide the envelope into its place at the moment of the small platform falling. A plunger now descends and creases the envelope by carrying it between the folder-axes, at the same time turning the flaps upwards in a vertical direction: the plunger, which descended as a whole, now divides into two parts, the ends rising and the sides remaining down to hold the envelope until the end-folders have operated; these latter turn over the flaps, the one on the right of the feeding-lad taking a slight precedence, and being closely followed by the gumming apparatus, which takes gum from an endless blanket working in a trough, and after applying it to the two end flaps, retires, at the same time the remaining half of the plunger moves upwards, to allow of the side folders turning over the remaining two flaps, the folder nearest the feeder taking precedence. During these operations, the end-folders have remained at rest, and the whole four open simultaneously. The taking-off apparatus, with its fingers tipped with vulcanized caoutchouc, now moves forward over the folded envelope, which is lifted upwards by the rise of the small platform and retreats with it, placing each envelope, as it is successively folded, under those which have preceded it. The envelopes are now knocked over on to an endless blanket, and

are conducted by it between two cylinders for a final squeeze, and then rise in a pile up the trough, seen against the right arm of an attendant, who is represented in the engraving as fetching away the folded work. There is a provision in the machine by which the gummer is prevented placing gum upon the platform, in case the feeder omits feeding in an envelope. This machine works at the rate of 2,700 envelopes per hour, and although superseding hand-labour in folding, it is satisfactory to find that, instead of displacing hands, its introduction, by extending the consumption, has, in reality, created work for more than it has displaced.

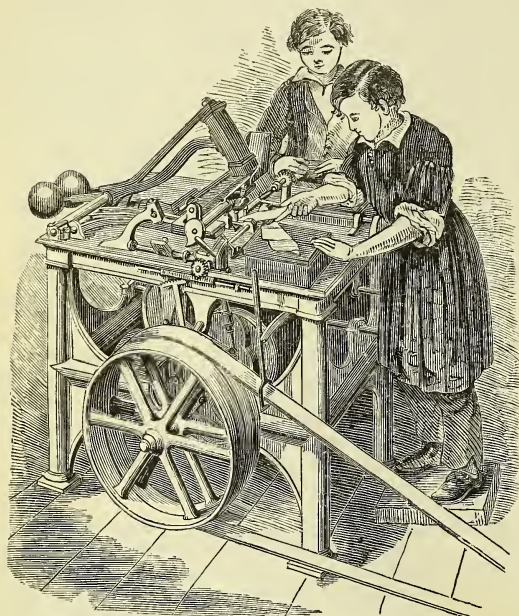

Hill and De la Rue's Envelope Folding machine.

Although the fashion of using envelopes was common in France, and had been, to a small extent, introduced into England prior to 1839, yet their consumption was too insignificant to call forth any but the rudest mechanical appliances. It is to the stimulus created by the adoption in, 1839, of Mr. Rowland Hill's system of postage reform, and the consequent increased demand for envelopes, that their manufacture owes its rank amongst the arts, and its possession of some of the most ingenious machinery recently invented.

The total annual number of letters passing through the Post-office in the United Kingdom before the change in the postage was about 76,000,000. The fourpenny-rate, and the alteration in the system of charge by number of enclosures to that by weight, was introduced on the 5th of December, 1839, and on the 10th of January, 1840, the rate was reduced to one penny: during that year the number of letters increased to 169,000,000, about half of which were enclosed in envelopes. The number of letters has been steadily increasing since that period, and during the year 1850, it reached the astonishing number of 347,000,000, or 1,000,000 per day; the proportion of letters enclosed in envelopes has likewise increased from one-half to five-sixths of the total quantity, so that in round numbers 300,000,000 of envelopes pass annually through the Post-office; besides which there is nearly an equal number used in private conveyance. What does this million of envelopes contain? Their expo-

sition would furnish an instructive and entertaining study.

In illustration of the articles sometimes sent by post, it may be cited, that some years back Professor Henslow was in the habit of receiving, from members of an agricultural society which he had established, specimens of living slugs of various kinds, sent for examination, with a view to his advice for their extermination. Were it not for the cheap postage many of the publishing societies now in existence would not have been established, on account of the expense of collecting manuscripts, transmitting proofs, and circulating books. But it is not only in this way that the postal reform has extended its benefits, for with the reduction of rates a liberal policy has increased the facilities of delivery by the establishment since 1839 of 4,600 new post-offices, which are estimated as serving about 14,000 villages.

Returning to the manufacture of envelopes, we find but little progress until March 1845, when Mr. Edwin Hill and Mr. Warren De la Rue took out a patent for cutting and folding machinery. Until this period, envelopes had been folded by hand, by means of a bone "folding-stick," an experienced workwoman folding about 3,000 per day.]

Papers ornamented in the water-mark.

Articles of Stationery.

Plain envelopes, folded by machinery.

Envelopes, with seal flaps, embossed, plain, and in cameo.

Envelopes, goffered, lace-perforated, and embossed.

Embossed and lace letter papers.

Specimens of writing papers, highly glazed, and in fancy packets.

Specimens of writing papers, highly glazed, goffered, and in fancy packets.

Packets of envelopes, in boxes.

Note and letter paper, in boxes.

Papetieres—envelopes and note papers, in fancy wrappers.

Newspaper envelopes. Paper-cloth envelopes.

Document bands, made of paper, lined with caoutchouc.

Cards for weddings, envelopes and "At home" notes, wafers and ties, silver-edged, printed in silver, plain embossed, and embossed in silver.

Cards, envelopes, and letter and note papers, plain and embossed, for mourning.

Surface-coloured and enamelled papers, coloured by hand and by machinery, patented by Warren De la Rue.

Gelatine papers. Embossed papers.

Papers printed in colours, gold and silver, and metal colours.

Iridescent papers, the changing colours of which are produced by a thin film of colourless varnish, patented by Thomas De la Rue.

Nethographic papers, or papers printed from wire-cloth. Patented by Thomas De la Rue.

Plain gold and silver papers.

Embossed gold and silver papers.

Gold borders, for box makers.

Pasteboards, Cards, &c.

Playing cards, with plain and ornamental backs, comprising a variety of floral and fruit designs, some printed in eight colours, patented by Thomas De la Rue.

Message-cards, plain, white, tinted, goffered, enamelled, and iridescent.

Drawing-boards, plain and embossed.

Mounting-boards, tinted and plain.

Printing.

T. De la Rue and Co.'s catalogue, as a specimen of type printing.

Ornamental tickets and labels, in plain printing, printed in gold and colours, and embossed.

Box-tops, printed in gold and colours, and embossed.
Bands for piece goods, printed in gold and colours, and embossed. Book-covers.
Ball-tickets, admission tickets, and programmes.
Printing inks.

Bookbinding.

All the designs are produced by the combination of four hundred new tools, cut from designs by Mr. Owen Jones.

Albums, bound in wood, leather, and velvet.
Scrap-books. Portfolios. Music books. Manuscript books.

Memorandum books. Indelible diaries.
Pocket ledgers, and account books.
Solid sketch-books and drawing-blocks. Drawing books.
Writing-desks, cabinets, and envelope-cases, in wood, leather, and velvet.

Pocket-books, wallets, and card-cases, in leather and velvet. Sermon, tourist, and note-cases.

Despatch-boxes. Playing-card boxes. Pocket chess-boards.

Blotting-cases, in wood, leather, and velvet.
"MacCubes," or pamphlet, letter, or music-holders.

77 ARMSTRONG, JOHN, 11 *Great College Street North, Camden Town.*—Sculptor.

An illustrated music sheet, containing two sets of quadrilles. No. 1. "Quadrilles Antique." No. 2. "Quadrilles of All Nations." Arranged by Philip Klitz, engraved by the exhibitor. Published by John Klitz, No. 193 Tottenham Court Road.

78 CASLON & Co., *Chiswell Street*—Producers.

Specimens of caligraphic type, engraved and produced under the superintendence of Mr. E. Boileau. Printed specimen. The caligraphic types in chase.

Specimens of improved coloured printing inks, manufactured so as to be readily mixed with the varnish when wanted. By an improved process these colours, after having been deprived of all extraneous substances, are reduced to the finest powder, requiring only the use of a palette knife to mix them to the consistency of ordinary printing ink, thus effecting a great saving, and facilitating the labour of the ornamental printer.

79 DOBBS, KIDD, & Co., 134 *Fleet Street*—Designers and Manufacturers.

Embossed drawing-boards, cards, and paper; enchased or lace-bordered cards and paper; also, embossed tableaux, exhibiting the application of embossing to the fine arts.

80 STOKES, ROBERT, *Ivy Cottage, Kingsland*—Inventor.

Three bottles of chemical ink. This ink may be employed on writing paper or parchment besmeared with grease. It is intended to be serviceable to butchers, bakers, oilmen, conveyancers, and solicitors.

83 HEYWOOD, JOHN, 170 *Deansgate, Manchester*—Manufacturer.

Foolscap quarto copy-books, with printed headings.
Post quarto copy-books, in two qualities of paper.

84 HAMER, ALFRED, *Horsforth, near Leeds*—Manufacturer.

Cloth papers for pressing and finishing woollen cloths. Press papers for stuff goods, both rolled and glazed. Glazed papers used for cotton goods. Gun wadding of a new description.

85 HASTINGS & MELLOR, *Leeds*—Manufacturers.

Press papers, for pressing woollen cloths. Brown papers, glazed and unglazed, for wrapping up woollen and other manufactured articles.

86 KNIGHT, J. Y., 39 *Briggate, Leeds*—Manufacturer.

Ledgers, royal folio paper, ten quires, white vellum, morocco bands; smaller account-books, in common binding. These books, when open, present a perfectly flat surface.

87 BAGSTER, SAMUEL, & SONS, 15 *Paternoster Row*—Producers.

Polyglot bible, printed in separate pocket volumes, which correspond, page for page, with each other; so that a convenient polyglot Bible of two, three, four, or more languages may, at pleasure, be formed by placing the required number of volumes before the reader.

Other specimens of typography and binding.

88 CROSS, GEORGE, 2 *New Coventry Street*—Inventor and Manufacturer.

Print collector's improved scrap-book, without guards, by which prints, drawings, &c., may be put close up to the back, and withdrawn without injuring their edges.

89 RIVIERE, ROBERT, 28 *Great Queen Street, Lincoln's Inn Fields*—Designer.

Specimens of bookbinding, viz.:

Spenser's works, folio, morocco, tooled with a double interlaced monogram (R. Riviere); the inside covers tooled with cipher E. S.

Virgili Opera, royal 8vo, inlaid with variegated leather on white morocco; inside covers tooled in foliated curves. Common Prayer, folio, in antique morocco.

Chronicles of England, 4to, tree-marbled calf.

[Inlaid or mosaic binding is produced by sticking various coloured leathers, silk, velvet, or paper on the cover, and finishing the joints by gilding.

Tree-marbling is the mottling or marbling caused by pouring a solution of green copperas (protosulphate of iron), on the cover, and causing it to flow somewhat in the form of a tree.—W. D. L. R.]

90 FERGUSON BROTHERS, *Edinburgh*—Manufacturers.

Specimens of printing type—nonpareil, minion, brevier, bourgeois, long primer, and small pica.

91 NEIL, ROBERT, 13 *North Bank Street, Edinburgh*—Designer and Manufacturer.

Specimens of bookbinding, viz.:

An imperial quarto Bible, morocco super extra, morocco insides, with satin fly-leaves. The outside of the boards and back is a specimen of hand-tooling, illuminated; and the inside of the boards the same, not illuminated; in the interior of the oval on each side of the shield, on white morocco, is a family register; and on the satin fly-leaves, is another specimen of blocking; on the edges, are the etchings of three churches—top, St. John's, Edinburgh; bottom, St. Giles', Edinburgh; front, St. Mungo's, Glasgow.

A morocco case for the Bible, so designed that the Bible may be fully seen, without handling or removing it from the cushion at the bottom of the case,

92 SINCLAIR, DUNCAN, & SON, *Whiteford House, Edinburgh*—Designers and Manufacturers.

Small founts of music type of different size and body. Cases containing the numerous characters—about 300 in each fount—with a plan showing the position and number of each separate character, for the setting up of any piece of music, however difficult.

Specimen-pages of each of the above music founts, printed from type and stereotype plates. Books containing specimens of all the book and newspaper letter founts. Specimen-sheets of uniform founts of book and newspaper letter.

93 WATERSTON, GEORGE, *Edinburgh*—Manufacturer.

Specimens of sealing wax and wafers of various colours and qualities.

94 MACKENZIE, W., *London Street, Glasgow*—Inventor.

A volume printed in church text, illuminated with red capitals; the types of each sheet were composed only once, and both colours were printed from the same form without lifting, a method which secures perfect register,

without incurring the expense of composing, as in the usual way, separate forms for each colour. Several specimen pages of this mode of printing, showing its general applicability.

96 **BANCKS BROTHERS**, *Weirhouse Mill, Chesham*—Manufacturers.

Patent writing-papers, embellished with ornamental designs, and authenticated by autograph signatures in the water-mark.

[The water-mark on paper was, until within a very short period, confined to the ribbing of laid-papers, or the distinctive mark of the paper-maker. Recently, ornamental designs have been produced, by means of wires sewn on the hand-mould or the dandy-roller of the paper machine, of which specimens are exhibited. This improvement was introduced by the Messrs. Busbridge. The process consists in forming the required design in brass plates, which are sewn on the mould or dandy-roller.]

97 **BUDDEN, EBENEZER**, *Cambridge*—Designer and Manufacturer.

Specimens of bookbinding:—Album, inlaid in colours, with interlacing band pattern, edged with body colours, inside joints and vellums inlaid, gilt, and painted; the leaves gilt, silvered, and painted with brilliant colours.

Bible in purple morocco, with gilt cover and joints.

98 **WHITELEY & SONS**, *Stainland*—Producers.
Specimens of press boards.

100 **SMITH, EDWARD**, *Felling Shore, Gateshead*—Producer.

Glazed brown paper, manufactured by Messrs. Thomas Gallon & Co., paper brokers, Felling Shore. Glazed by an improved process.

101 **COWAN, ALEXANDER, & SONS**, *Valley-field Mills, near Edinburgh, and 45 Upper Thames Street*—Manufacturers.

Specimens of paper. Large cream laid, large blue laid, thick cream laid, and thick blue laid, post folio, note and letter papers. Blue wove and laid bank post for foreign correspondence, &c. Blue laid medium and demy for account books. Bank note paper. Envelopes in packets. Pictorial note papers, with views in oil colours. Fine printing demy. Account books, various.

102 **WILDES, WILLIAM**, *Snodland, Rochester*—Designer and Manufacturer.

Specimens of writing paper ornamented by wreaths of flowers in the water-mark.—Registered design.

103 **WISEMAN, HENRY RICHARD**, *9 Trinity St., Cambridge*—Manufacturer.

The King's Bible, in two volumes, printed at the Pitt Press, Cambridge, bound in royal scarlet morocco, tooled, with illuminated vellum fly-leaves, tooled edges, &c.

106 **CUNDALL & ADDEY**, *21 Old Bond Street*—Publishers.
Specimens of bookbinding:—

In gold paper, the ornamental design being printed on it in colours, by means of wooden blocks.

In morocco, covered with an elaborate design in pierced metal, enamelled, gilt, and chased. The metal-work by Thomas Burt and Sons.

In ornamental cloth; in morocco, inlaid with a pierced ivory tablet.

In morocco, in a style suitable for ecclesiastical books; executed by James Hayday.

In morocco, using a decorated china tablet for the side of the book, with gilt bosses for its protection. The tablet manufactured by W. T. Copeland, at Stoke-upon-Trent.

107 **KNIGHT & HAWKES**, *Stanhope Foundry, 13 Clerkenwell Close*—Manufacturers.

Stereotype casts from printing type, of the various sizes and characters; in English, German, Irish, Syriae, Hindostanee, Chaldee, Persian, &c., together with the type and the moulds.

Stereotype casts from engravings in wood, steel, &c.

Specimens of stereotype plates for surface printing in colours.

Stereotype plates for embossing.

108 **ROCK BROTHERS & PAYNE**, *11 Walbrook*—Manufacturers.

Account books with metallic bands; fancy note and other papers; blotting pads; sketch books; publication folios; and memorandum books with new elastic bands for clasps.

Albums and scrap-books, three of the latter containing nearly 2,000 views in England: produced by the exhibitors.

109 **ORR, W. S. & Co.**, *Amen Corner*—Producers.

Various works in plain and ornamental binding, including russia, morocco, calf, antique calf, and cloth.

Series of maps, illustrating the physical features and phenomena of the globe.

110 **PECKERD, JOHN PARSONS**—Designer.

Original design in penmanship, showing the effect produced by Tate's exchequer ink.

111 **WESTLEYS & Co.**, *Friar Street, Doctors' Commons*—Manufacturers.

Various specimens of bookbinding, in plain and ornamental styles; several gilt, with appropriate and emblematical tooling; including the Holy Bible, royal folio, Oxford, bound in purple morocco, with enchased clasps, corners, and centres; and painted edges, in gold and colours, with appropriate Scripture texts from the Old and New Testament.

112 **FOLKARD, W. J.**

Specimens of printing from wood blocks.

113 **EVANS, EDWIN**, *Yorkshire Street, Oldham*—Designer.

Specimen of typography.

117 **MACNAIR, WILLIAM**, *Glasgow*—Producer.

Specimens of bookbinding: Imperial quarto volume, bound in morocco, super-extra, modern style; Encyclopædia of the Fine Arts, demy quarto, bound in calf, super-extra, antique style; Milton's Paradise Lost, imperial octavo, morocco, super-extra, antique style; Gallery of Nature and Art, royal octavo, calf, super-extra, modern style.

118 **STIRLING, W.**, *Kenmure House, Glasgow*—Proprietor.

A copy of the Bible printed by Her Majesty's printer in Scotland in 1811: only 100 copies of this edition were printed on large paper; it is bound in white morocco, and gilt, as a specimen of bookbinding in Glasgow.

119 **TODD, JOHN**, *Perth*—Manufacturer.

Writing inks and ink powders, known as the "Perth writing inks," made up in different sizes of bottles or packages. One is a carbonaceous ink, said to be indestructible by the action of air or light, or any known chemical agent.

120 **PARKER, J. H.**, *Oxford*—Proprietor.

Illustrated books.

121 **PLOWMAN, J.**, *St. Aldate's Street, Oxford*—Inventor and Manufacturer.

Portable copying letter-case, for taking copies of letters, documents, &c., written in ink, by the mere pressure of the hand. The process is simple and expeditious.

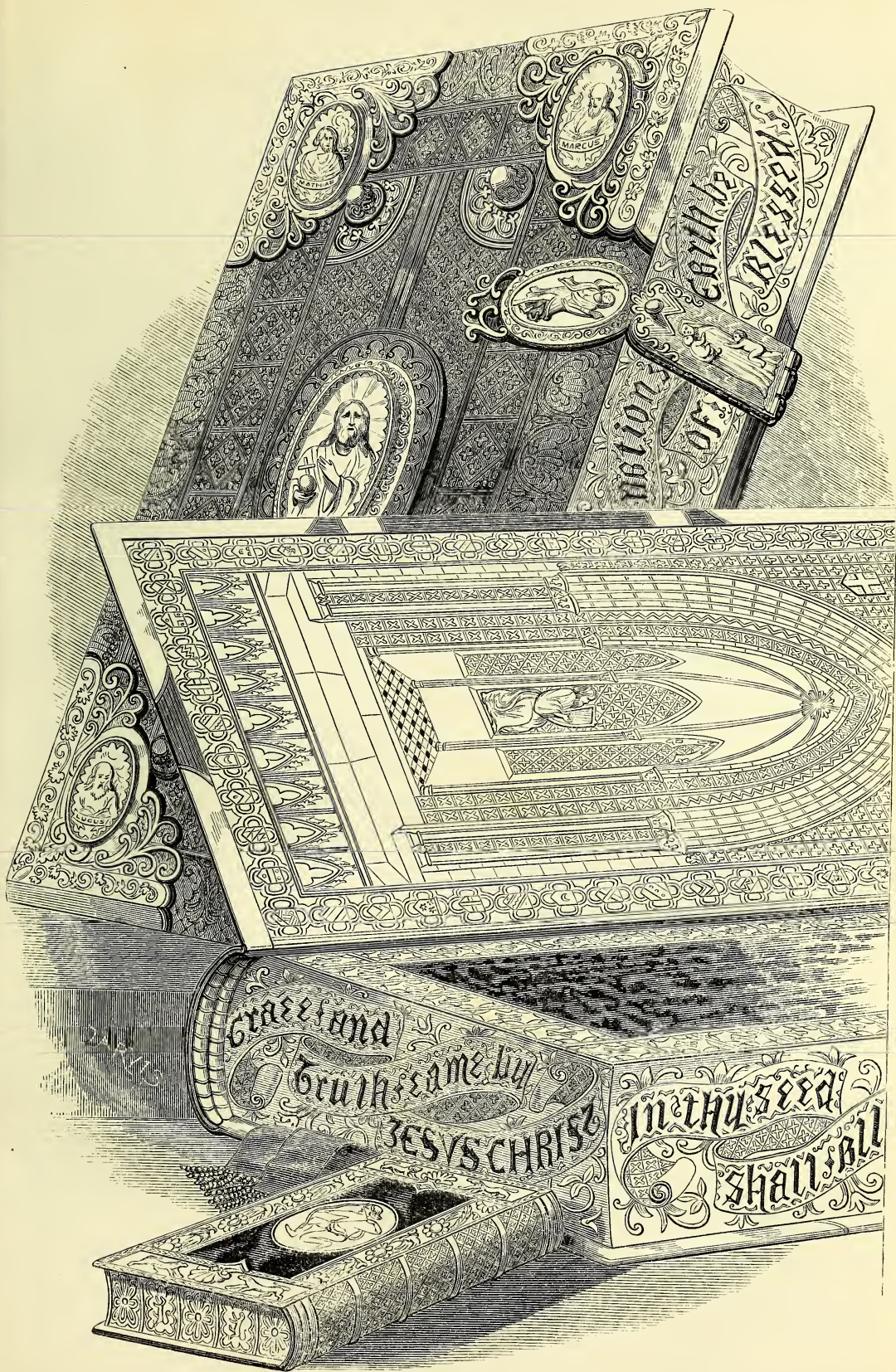

123 COCKS, ROBERT, & Co., *New Burlington Street*—
Part Manufacturers.

Dr. Boyce's collection of Cathedral Music, edited by Joseph Warren, in 3 vols., large folio; containing the services and anthems of the great English Church composers from the period of the Reformation, viz., Thomas Tallis, Richard Farrant Byrd, Bevan, John Bull, Morley, Drs. Christopher Tye, Mirehild, Henry Aldrich, Robert Creighton, and Benjamin Rogers; also by Orlando Gibbons, Thomas Tomkins, John Parsons, William Munday, William Lawes, Henry Purcell, Pelham Humphrey, Jeremiah Clark, Dr. John Blow, Matthew Locke, Goldwin, Weldon, Michael Wise, Dr. Turner, and Dr. William Croft, with memoirs of the composers, and a portrait of Dr. Boyce. Exhibited as a specimen of the art of engraving and stamping musical notes on plates of pewter—also of music, printing, and bookbinding. This work is printed from more than 1,200 plates.

[William Boyce, Mus. Doc., was born in 1710. He was organist to several churches successively; and finally, on the death of Dr. Greene, 1775, of the Chapel Royal. This great work was the projection and partly the execution of his predecessor (Dr. G.) Boyce died in 1779, and was buried in St. Paul's Cathedral.—H. E. D.]

124 FIGGINS, VINCENT & JAMES, 17 & 18 *West Street, Smithfield*—Designers and Manufacturers.

Specimens of type—some of the ornamental letters being of French and German design.

Raw materials of type metal—lead, tin, and antimony. Type metal of different qualities.

Type mould and matrix. Type mould taken to pieces. Two wood-cuts; metal matrices made from them; casts from the matrices.

Electrotype copper matrices from casts, illustrative of the process of polytyping wood-cuts.

Form, super royal, containing upwards of 220,000 pieces of pearl type, weighing 10 stone, held in suspension by lateral pressure, technically called "locking up."

127 NOVELLO, J. ALFRED, 69 *Dean St., Soho, & 24 Poultry*—Producer.

Specimens of music type, and a sketch of the method of printing music from moveable types, showing all the various pieces, their shapes, and the cases in which they are arranged before the compositor.

128 MANCHIN & MOREL, 8 *Wilson Street, Gray's Inn Road*—Manufacturers.

A wood-cut, stereotype plates, and engravings.

[The bituminous stereotype plates are for printing purposes; and though new in this country, have been extensively used in France for the last two or three years; their advantage over the metal plates consists in their hardness, which renders them more lasting, and in the fineness of their impressions, which is stated to be equal to those of the wood-cut.]

134 CLARK, W., *Dunfermline, Scotland*—Designer.

Specimens of bookbinding, viz.:

Bible, 8vo, full-bound in maroon Turkey morocco, gilt edges, hand-tooled in gold on back and sides, with satin linings.

[Hand-tooled designs are usually employed in the higher class of bindings, and are formed by the combination of a number of separate tools arranged according to the taste of the workman.—W. D. L. R.]

Chalmers' History of Dunfermline, 8vo, full-bound in red Turkey morocco, hand-tooled in gold and silver on back and sides, and with silver and satin linings.

Wylie's Scenes from the Bible, 8vo, full-bound in scarlet calf, fancy bronzed paper linings, gilt edges, hand-tooled back and sides, with gold and silver.

Cheever's Winding of the Water of Life, 8vo, full-bound in green calf, fancy bronzed paper linings, gilt edges, hand-tooled back and sides, with gold and silver

[Bookbinders, previous to gilding, prepare the leather with white of egg, or glair, as it is technically called, and, after it has dried, apply the gold or silver leaf with heated tools of the required design. The glair softens and attaches itself to the gold, which is readily removed from those parts not so impressed.—W. D. L. R.]

The Great Teacher, by Dr. Harris, post 8vo, half-bound in green morocco, scarlet cloth sides, fancy bronzed paper linings, gilt edge, hand-tooled, gilt on back, the sides wrought with gold and silver.

135 CLARK & DAVIDSON, *Mauchline, Scotland*—Manufacturers.

Specimens of bookbinding in wood, &c., viz. :—Pictorial Bible, bound in wood boards, ornamented with arabesques.

Songs of Scotland, bound in wood boards, in imitation of tartan, with view of Banks of Doon, in ornamental shield.

Portfolios, with wood boards, in imitation of tartan, and views; Balmoral Castle, in ornamental shields; Holyrood Palace, in ornamental shield; Andernach on the Rhine, &c.

Scotch snuff-box, and Scotch fancy wood-work.

Note-books. Metallic books, with arabesques. Ornamented wood flower-vases. Enamelled wood egg-cup stand. Portable work-box. Thread-reel boxes. Crochet-boxes and cases. Needle-books, boxes, and cases. Snuff-boxes of fancy wood. Match-boxes. Toilette-bottle cases. Razor-cases and strops. Spectacle-cases and slips. Paper-folders and book-marks. Pomatum and scent boxes; and scissor-cases. All with imitation of tartan.

136 BRADBURY & EVANS, *Whitefriars*—Producers.

Specimen of letter-press and wood-cut printing.

137 DUDMAN, JAMES, *Camberwell Place, New Road*—Inventor.

Specimens of three sorts of self-sealing envelopes :—First—A metallic capsule attached to the envelope, containing cement, which, by the pressure of the thumb, spreads and seals. Second—Adhesive cement attached to the envelopes, in the sealing position, with a piece of metallic foil between the cemented surfaces, on removing which, by pressure, the envelope is sealed. Third—The same in principle as the last, without the interposing foil, a portion of the envelope being turned between the cemented surfaces: this requires warmth, as the cement is harder than in the preceding.

139 WRIGHT, J., 14 & 15 *Noel Street, Soho*—Producers.

Various specimens of bookbinding, including the illuminated books of the middle ages, by H. Noel Humphrey and Owen Jones. Imperial folio, bound in brown morocco; the boards cut and blued; tooled in the antique style, the edges gilt and tooled, and many other choice works, in varied and appropriate ornamental styles.

140 PICKERING, WILLIAM, 177 *Piccadilly*—Producer.

Specimens of printing, viz. :—

1. The Victoria Book of Common Prayer, carefully collated, and adapted to the present reign; printed in large old English type, by Mr. Whittingham, with floriated initial letters, and the rubrics in red.

2. King Edward VIth's Book of Common Prayer, with musical notes by John Merbecke, 1550.

3. Euclid, the first six books, with coloured diagrams and symbols, used instead of letters, for facilitating a knowledge of Euclid. This work is a specimen of letter-press printing in colours, not hitherto used.

4. The Princess Elizabeth, Francis I., and an enamel, being specimens of the dresses, decorations, missal ornament, and decorative art of the middle ages, by Henry Shaw, F.S.A.

141 ELLIS, HERCULES, *Hardwick Street, Dublin*—
Producer.

Specimens of poetry published by J. Smith, 49 Long Acre.

142 RALPH, FREDERICK W., *36 Throgmorton Street*—
Manufacturer.

Registered polychrest envelopes, made in three sizes, and self-sealing; invented to combine in one the note and envelope, so that the contents are always identified with the address and postmark; important in evidence; and for correspondence and business purposes, economical in regard to expense and time. When used as envelopes only, they are more secure for patterns and enclosures than those in common use.

143 DEWDNEY, JOHN, *Cullompton*—Manufacturer.

Specimens of paper.

144 BYAM, ELIZA, *Bazaar, Soho Square*—Producer.

Compound stationery case; travelling, writing, working, dressing, and refreshment case; lady's carriage companion, &c.

147 LAMB, JOHN, *Newcastle-under-Lyme*—Manufacturer.

Reel of pottery tissue-paper, used for printing earthenware from copper rollers by machinery.

Ream of pottery tissue for printing china and earthenware from flat copper plates.

Capstan, or piece of old round rope, and piece or length of old flat coal-pit rope, the material from which the paper is manufactured.

[The paper manufactured for the purpose of the potter was made of linen rags, but it is now almost always made from cordage, and is unsized. The reason of this is, that being printed on with ink, of the colour required on the ware, and of such a nature as to fix firmly, it is rubbed upon the "biscuit" with a roll of flannel, and being placed aside for a short period, it is plunged into water, and the bibulous paper removed with a sponge, leaving the impression on the piece of pottery.—R. H.]

148 NEWBERY, J. & R., *2 and 3 Hemlock Street, Carey Street*—Manufacturers.

Gold and coloured papers for bookbinding, &c.

149 VENABLES, WILSON, & TYLER, *17 Queenhithe*—
Manufacturers and Wholesale Stationers.

Specimens of the present state of the paper manufacture in Great Britain, classified and arranged in portfolios and reams.

Specimens of the material used in its various stages of preparation for the manufacture of paper.

[Among the specimens, which are very numerous, and contain patterns of all the papers in ordinary use, are several descriptions manufactured for the occasion, of a very superior character, and possessing improved qualities.]

150 MILLER & RICHARD, *Edinburgh*—Founders.

A specimen of the smallest types ever manufactured in this country, cut and cast expressly for the Great Exhibition. The whole of Gray's "Elegy," consisting of thirty-two verses, is contained in two columns, $3\frac{3}{4}$ inches deep.

151 AUSTIN, WILLIAM, *5 Furnival's Inn Place*—
Manufacturer.

Fancy boxes, &c.

152 BURKE, THOMAS H., *Bull Head Court, Newgate Street*—Producer.

Fancy stationery.

153 HAMPSON, B., *14 Fountain Street, Manchester*—
Manufacturer.

Labels, tickets, &c., used to ornament manufactured goods.

154 SPECIMENS OF BOOKS AND TRACTS OF THE RELIGIOUS TRACT SOCIETY, instituted 1799. Depositories, 56 Paternoster Row, 65 St. Paul's Churchyard, and 164 Piccadilly. Treasurer, John Gurney Hoare, Esq.; Honorary Secretaries, Rev. W. W. Champneys, M.A., and Rev. Ebenezer Henderson, D.D. Corresponding Secretary, Mr. Jones.

The Society was formed to promote the circulation of religious books and treatises in foreign countries, as well as throughout the British dominions. It constitutes a Christian union of members of the Established Church and of Protestant dissenters. It has printed important tracts and books in about 110 languages; its annual circulation from the Depository in London, and from various foreign auxiliaries, amounts to about 24,000,000; its receipts, for sales and benevolent objects, to more than 62,000*l.*; and its total distribution to March, 1851, including the issues of its affiliated societies, to about 549,000,000 copies of its publications. There are now about 4,743 English publications, besides several hundred in foreign languages, on its catalogue. These works are varied in size and contents, and suited to different classes of the community. Several books and tracts specially designed to improve and commemorate the Great Exhibition have been issued in English, French, German, and Italian. By a carefully arranged system in the concerns of the Depository, the sale of the publications is made to cover all the expenses of producing them, and of the necessary establishment of the Society. Thus the whole of the subscriptions, donations, and contributions is applied to the gratuitous circulation of its publications, without any deduction or charge whatever. In aid of home and foreign benevolent objects, the Society receives about 6,560*l.* per annum, while its grants during the past year were 8,560*l.*, being 2,000*l.* beyond the receipts. The Committee have supplied 3,028 libraries, at half-price, to National, British, Parochial, Day, and Sunday Schools, which were unable to pay the full amount. The total grants of libraries, for various interesting objects, amount to 6,055.

The Society has translated, printed, and circulated works in the following languages:—

Western Europe.—English, Welsh, Gaelic, Irish in native characters, Irish in Roman characters, Manks, French, Breton, Spanish, Portuguese.

Northern Europe.—Icelandic, Swedish, Lapponese, Finnish, Danish, Norwegian.

Russian Empire.—Russ, Revel Esthonian, Dorpat Esthonian, Lettish, Tartar-Turkish, Buriat, Calmuc.

Central Europe.—Dutch, Flemish, German, German vulgar, Lithuanian, Polish, Wendish, Bohemian, Slavonic, Magyar.

Southern Europe.—French, German, Latin, Romanese, Engladin, Italian, Maltese, Modern Greek, Albanian, Turkish, Turkish in Greek character, Turkish in Armenian characters, Moldavian, Bulgarian, Syriac.

Caucasian and Border Countries.—Georgian, Georgian vulgar, ancient and modern Armenian.

Semitic Languages, &c.—Hebrew, Arabic, Syriac, Persic.

India.—Sanskrit, Hindustani, Urdu in Roman characters, Bengali, Bengali-Anglo, Oriya, Hindui, Nagree, Teloo, Canarese, Tamil, Malayalim, Tulu, Mahratta, Gujaratti, Cingalese, Indo-Portuguese.

China and Indo-Chinese Countries.—Chinese, Assamese, Shyam Nagas, Burmese, Peguan, Taleing, Karen, Siamese, Laos, Cambodian, Cochinchinese, Loo-Chooan, Japanese, Corean.

Hither Polynesia.—Malay in Roman characters, Malay in Arabic, Malay Low, Buggis, Dajak, Javanese, Madurese.

Further Polynesia.—Hawaian, Tahitian, Rarotongan, Tonga, Samoan, New Zealand.

For Africa.—Malagasy, Sechuana, Kaffir, Isubu, Amharic, Spanish Hebrew.

America.—Karif, Mosquito, Greenlandish Esquimaux, Mohawk, Ojibbewa.

[Through the disinterested agency of devoted friends and missionaries, of different denominations, several languages have, for the first time, been brought into a written form, and a sacred character has been given by the Christian press to the earliest literature of a people just emerging from a state of barbarism. As an illustration of the extent of the Society's operations, it may be stated that Bunyan's celebrated work, "The Pilgrim's Progress," has been issued in 28 of the principal languages of the earth, spoken probably by more than one-half of the human family. In some instances the work has been printed in Roman characters, as in the following examples:—

In *Malagasy*, for the use of the persecuted Christians in the island of Madagascar, thus:—

Raha niaingia tety ambony tany aho, dia nijanona tamy ny fitoerana iray nisy lavabato, ary maudry tao aho, ka natory; ary raha natory aho, dia nanonofy.

In *Tahitian*, for the inhabitants of various islands in the Pacific Ocean, thus:—

I to'u hahaeere raa na roto i medebara o teie nei ao, haere atura van i te hoe vahi, e ana tei taua vahi ra, tapae atura vau i reira e roohia ihora i te taoto i roto i taua ana ra.

The original of these translations is the following:—As I walked through the wilderness of this world, I lighted on a certain place where was a den, and laid me down in that place to sleep, and as I slept I dreamed a dream.

Specimen of Chinese tract, entitled "The Summary of the Gospel."—

罪若	罪罪
紅不	大紅
惡來	似似
多到	山血
亦不	必必
宜要	變洗
哀求	平似
求救	地雪

155 SWANN, THOMAS FRANCIS, 43 *Southampton Buildings*
—Inventor and Manufacturer.

Specimen of red marking-ink for linen, silk, &c.

156 WEBB, WILLIAM, 34 *Southampton Buildings*,
Chancery Lane—Producer.

An improved instrument for writing with pens and ink several copies simultaneously.

157 HOOD, J. H., 25 *Red Lion Square*—Producer.

Improved portfolios, illuminated vellum binding, &c.

158 LEIGHTON, JANE & ROBERT, *Harp Alley, Shoe Lane*.

Specimens of bookbinding, exhibited for novelty, cheapness, and design. The process of binding is conducted, as far as possible, by machinery, each book being ornamented at a blow by an engraved die. Designs by Luke Limner. The covers, in imitation of carved ebony, are manufactured of papier maché, by Messrs. Jackson and Son, of Rathbone Place. Each cover bears the designer's

name. The book cloths are rendered waterproof by Leighton and Son's new process, and manufactured by Mr. James Wilson, of 128 St. John's Street, Clerkenwell. The silver leaf used to decorate certain of these books, is prevented from tarnishing by a new process, invented by Leighton and Son. The clasps, and other metal work, are manufactured by T. J. Guy, of Harp Alley, Shoe Lane.

159 WODDERSPOON, JAMES, 16 and 17 *Portugal Street*,
Lincoln's Inn Fields—Designer and Manufacturer.

Specimen of an account book, in which the usual defect of breaking between the sections is prevented by the introduction of patent vellum cloth bands, which strengthen the book, without adding to its thickness at the back. The advantage of this new material is, that it will carry ink as well as paper; and it is stronger and thinner than any substance hitherto used for the same purpose.

160 GILL, H., *Dublin*.

Various quarto and octavo volumes containing specimens of illustrated printing.

162 RAINES, T., 24 *Great Ormond Street, Queen Square*—
Designer and Manufacturer.

Specimens of bookbinding.

163 LEWIS, Mrs. C., *Duke Street, St. James's*—Producer.

Specimens of bookbinding.

164 WATTS, W. M., 12 *Crown Court, Temple Bar*—
Producer.

Specimens of Oriental and other types, in sixty-seven languages.

The Lord's Prayer in Chinese characters, with the pronunciation of each letter; and a portion of the Liturgy, also in Chinese moveable metallic types.

The Lord's Prayer in embossed characters, for the use of the blind, in two systems.

165 ISAAC, JOHN RAPHAEL, 62 *Castle Street, Liverpool*—
Inventor and Proprietor.

Registered cabinet in oak, for containing maps, diagrams, &c., intended for use in general offices, and at public lectures. The handle, acting right and left, brings to view any particular map required.

Registered manifold stand in mahogany, for holding a portfolio, and suitable for an easel, music, and reading-desk.

165A BLACKWOOD & Co., 26 *Long Acre*—Manufacturers.

Bottles in earthenware and glass, having a lip or spout, for holding ink; the cork is drawn by means of a ring attached to it.

166 HODSON, J. S., 22 *Portugal Street, Lincoln's Inn*
Fields—Producer.

Specimens of letter-press printing, in various colours.

167 CAFFRY, JAMES, 18 *Palace Row, Armagh, Ireland*—
Producer.

A copy of a one-pound Ulster bank-note, executed on Bristol board, with a common pen; exhibiting pictorial designs of shipping, ploughing, &c., as a specimen of the caligraphic art.

168 LINES, EDWARD D., & Co.—*Plummers Row, Fieldgate*
Street, Whitechapel—Manufacturers.

Blue writing fluid.

169 BRETTELL, T., *Rupert Street, Haymarket*—Producer.

A hymn for all nations, by M. F. Tupper, D.C.L., F.R.S.; translated into thirty languages. The music composed by S. Sebastian Wesley, Mus. Doc.

170 EDINBURGH SCHOOL FOR THE BLIND, *Abbey Hill, Edinburgh*—Producer.

Dr. Foulis's tangible ink for the blind. This ink, although perfectly fluid, contains a large quantity of solid matter which is deposited on the paper so as to present a highly raised surface to the finger. Dr. Foulis's manuscript music notation for the blind. By means of this invention the whole of the characters in music can be represented by common pins stuck into a pincushion, with chords run through to represent the staves. Dr. Foulis's simple method of producing a raised surface on paper for the blind.

Mr. Gall's typhlograph for the blind. A simple apparatus to teach the blind to write. The invention is simple of application, and the writing is precise and occasionally elegant. Mr. Gall's system of arithmetic for the blind, accomplished by common pins stuck into a pincushion. Its simplicity is such that a blind person can make his calculations with a few pins on a pillow, or seat of a chair, &c. Mr. Gall's types for correspondence, by which blind persons can correspond with one another, or jot down memoranda for private use.

171 GALL, JAMES, *Myrtle Bank, Edinburgh*—Inventor.

Gall's triangular alphabet for the blind, which, by its similarity to the common Roman alphabet, is easily read by the eye, and may be taught without previous instruction. This alphabet is considered as an improvement on circular alphabets, by its angular form; the letters are rendered more distinct to the touch; and by the exclusion of the capitals, the attention of the blind is concentrated upon 26, instead of 52 letters, and the size of the printing may be reduced. Volume, containing the Epistle to the Ephesians, printed for the blind in Gall's triangular alphabet, with the letters serrated.

Gall's apparatus for writing by and to the blind. The blind can, by this invention, readily correspond by post, and can keep books and other memoranda. The apparatus consists of a stuffed frame on which the paper is placed; of a cover with bars to guide the lines, which are written from the bottom upwards; and of small stamps, with the letters formed of common pins, which are pricked through the paper, and read on the opposite side. By means of the two register points on each side of the frame, and by shifting the cover one half line up, the paper is written on both sides, each perfectly legible either by the fingers or the eye.

172 BAXTER, —, *Frome-field School, Frome, Somerset*—Producer.

The National Anthem with music, on a large scale, for the use of schools.

172A WEBB, ELIZ., *Kirby Hall, Horton*.

Church services ornamented with needlework.

174 MUIR, ROBERT, 4 *Dunlop Street, Glasgow*—Inventor.

Electro-stereotype plate for letter-press printing. This specimen is from a mould of gutta percha, taken from a page of diamond types in a screw press. The gutta percha was laid on warm, the pressure applied immediately, and left on for fifteen minutes. When the mould was taken off it was brushed over with plumbago, and copper deposited upon it by the known process. When the copper deposit is backed up with gutta percha, it is ready for press.

The advantage of electro-stereotype over stereotype is, that it will last much longer, and work much cleaner. The exhibitor has worked one of each together, and when the stereotype was completely worn, the electro-stereotype was as good as at first.

Gutta percha plate to be used in letter-press printing. Plates made of gutta percha from wood-cuts, will work a large impression with letter-press; advantageous when wood-cuts are expensive, as the originals might be saved.

Gutta percha plates can be made in a short time at a trifling cost; and when 2, 4, or 6 are worked together, it will greatly facilitate the work, and lessen expense.

Make a mould from a wood-cut by the method above described; brush it over with plumbago; lay it on the press, face up, and put warm gutta percha into it; apply the pressure as before. Several plates may be got from the same mould.

[This process appears to offer many advantages, if the practical difficulties of completely covering the impressions of the type letters, or the lines of an engraving, with plumbago, are not too great. The gutta percha plate, being properly prepared, is connected with the voltaic battery, and placed in a solution of the sulphate of copper, which, then undergoing electro-chemical decomposition, deposits pure copper in all the lines and over the entire surface. It would appear, if lead was used instead of gutta percha for backing the plate, that it would be better fitted for printing than when gutta percha is employed.—R. H.]

175 WYLD, JAMES, *Charing Cross East, 454 West Strand, 2 Royal Exchange, and the Great Globe, Leicester Square*—Producer.

A General Atlas, containing 67 maps, of the various parts of the world, showing their respective physical and political features, including the recent discoveries. Columbian folio, full-coloured, and half-bound in Russia.

A General Atlas, being a useful selection from the preceding. Full-coloured; 41 maps.

An Atlas of the World, comprehending 52 separate maps of its various countries, constructed and drawn from the latest astronomical and geographical observations. Imperial quarto, coloured, and handsomely half-bound.

School Atlas, with a copious index, containing upwards of 8,000 names of places.

Popular Atlas, containing 48 maps of the various parts of the globe, with letter-press description to accompany each map. The World, on Mercator's projection. A new map, containing the most recent geographical information, and constructed upon a new principle; 4 large sheets. The World, on Mercator's projection; coloured, one large sheet.

General Map of Europe, drawn from the latest documents; divided into its empires, kingdoms, and states; showing the great roads, railroads, physical features, &c. Six sheets.

Post Roads of Germany, and the adjacent States, with the posts marked, the railroads, the sea-packet routes, and the internal steam navigation. Two sheets, in cases.

The British Isles, with the topographical and physical features; the lines of railway, their primary and intermediate stations; the land and water communications of the countries; and the steam-packet routes, with the distance from port to port. Compiled from the Ordnance Survey. Two sheets.

England, Wales, and the greater part of Scotland, a Railway and Topographical Map, drawn from the triangulation of the Ordnance Survey, and the surveys of the Railway Companies, and other sources of information, showing the lines of railways, the inland navigation, the great and cross roads, cities, market towns, and villages, with the physical features. Four sheets.

Plan of London and Westminster, with the Borough of Southwark, including the adjacent suburbs, with all the additions and improvements to the present time, reduced from the large survey, with an alphabetical list of the principal streets, squares, public buildings, &c., and reference to their situation on the plan; also a statistical table of the population, &c. Two sheets.

New Map of London, extending from Holloway to Camberwell, and from Kensington to the River Lea. One sheet.

Map of the country 25 miles round London, upon a scale of 1 inch to the mile, showing the turnpike and cross-roads, railroads and stations, rivers, woods, com-

mons, seats of the nobility and gentry, as well as the market towns, villages, &c. Four sheets.

Scotland, drawn from the topographical surveys of John Ainslie, General Roy, and others, with the post towns and offices, the turnpike-roads (both direct and cross), railways, and the distances between each town, and from Edinburgh. Two sheets.

Ireland, reduced from the Ordnance Surveys. Four sheets.

Asia, compiled from the most recent documents, in four large sheets.

India, from the latest authorities, showing the civil and military stations, with polemical table of reciprocal distances. One large sheet.

Islands of New Zealand and Chatham Group, from the Admiralty Surveys of the English and French marine, from the observations of the officers of the New Zealand Company, and from private survey and sketches. Two sheets, with plate of the harbours, sailing directions, &c.

North America, exhibiting the recent discoveries, geographical and nautical; drawn chiefly from the authorities of M. de Humboldt, Lieut. Pike, Messrs. Lewis and Clarke, Sir Alex. Mackenzie, Mr. Hearne, Col. Bouchette, Captains Vancouver, Ross, Parry, and Franklin, Back, Beechey, Dease, and Simpson, and Kellek; also describing the boundary lines between the territories of Great Britain, the United States, and the Mexican and Central States. Seven sheets.

Map of the Province of Canada, with part of New Brunswick to Halifax, and the United States from Boston. One sheet.

South America, drawn chiefly from the original manuscript maps of his Excellency the late Chevalier Pinto; likewise from those of the Brazil provinces, surveyed by Joas Joaquim de Rocha, a magistrate resident many years in those countries; also the Capitania of San Paulo, by Joao da Costa Ferreira. The late Spanish territories are extracted from the surveys of El Padre Francisco Manuel Sobrevela and others; together with the most authentic edited accounts of those countries by Humboldt and Schomburghk; showing also the boundaries and states. New edition. Eight sheets.

Africa, compiled from authentic accounts of travels, both ancient and modern, including those performed under the patronage of the African Association, by Messrs. Hornemann, and Houghton; also those of Lord Valentia, Sir Home Popham, Captains Lyon, Tuckey, and Clapperon, Messrs. Barrow, Bowditch, Brown, Bruce, Burchell, Ritchie, Salt, Laing, Denham, Landers, and Richardson, with the nautical surveys and observations of Captains W. Smith and Owen, R.N., assisted by the reports of the Missionary Societies. Six sheets.

Educational Maps. The World, on the globular projection, containing the most recent information. Eight sheets. Europe, drawn from the latest documents, showing its political divisions, cities, and principal towns; Asia, exhibiting its political divisions, from the best authorities; Africa, constructed from the most recent travels and other authentic sources; America, showing its political divisions, and containing the recent discoveries in the arctic regions; each in four sheets.

England and Wales, drawn from the triangulation of the Ordnance Survey, and other sources of information; showing the physical features, cities, and market towns; Scotland, with its cities, market towns, and physical features; Ireland, reduced from the Ordnance Survey, showing its cities, market towns, &c.

Twelve-inch globes, containing the modern discoveries, and the places of the stars on the celestial globe calculated to the present year; on high mahogany stands, &c.

[A map may be defined as a projection of the surface of the globe on a plane surface. As the form of the earth is nearly that of a sphere, it is evident that the only map which can truly represent the positions of places is that on the surface of a globe. That projection which comes the nearest to the true representation of the globe is

termed the "globular." On Mercator's projection some of the difficulties attendant upon circular projection are avoided: all the lines are right lines, and all the meridians are equidistant. The advantages of this projection are, that the bearing of every place is true with respect to other places, and distances may be measured correctly from it; but the spaces between the parallels of latitude increase as they recede from the equator, and in high latitudes the departure from truth is great.—J. G.]

176 LOVEJOY, GEORGE, *Reading, Berks*—Inventor.

Permanent, or indelible black writing-ink for public records, not affected by age or any of the ordinary chemical agents.

177 SHEAN, W. F., 14 *Halsey Terrace, Cadogan Street, Chelsea*—Producer.

Class roll, or school attendance register book.

178 WILSON, ROBINSON, *Whitehaven*—Producer.

The Descent from the Cross, executed in ten weeks with steel and crow pens and Indian ink. The outlines were taken from an old print, and no brush was used, the shading being performed with a piece of paper when the strokes were damp. On each cheek alone are upwards of two thousand strokes with the pen, imitating line engraving.

179 GALBRAITH, W. J. T., 26 *Bennett Street, Blackfriars Road*—Inventor and Manufacturer.

Indelible writing fluids.

180 OWEN, HORATIO, *Falcon Square*—Designer and Proprietor.

Specimen of typography, being the speech of His Royal Highness Prince Albert, at the Mansion House Banquet, together with translations into the German, French, Italian, Turkish, and Arabic languages.

181 KRONHEIM & Co., 32 *Paternoster Row*—Manufacturers.

A variety of fancy borders.

182 STEPHENSON, BLAKE, & Co.—Producers.

A various assortment of printing type.

183 DAVIS, J., 1 *Duke Street, North Parade, Bath*—Inventor and Manufacturer.

New system of music, and general instructions for the pianoforte, organ, pedal harp, &c.

184 REED & PARDON, 1, 2, & 3 *Lovell's Court, Paternoster Row*—Producers.

Various specimens of letter-press printing.

185 TAIT, W. J., *Church Street, Rugby*—Producer.

A variety of school outlines.

186 HUME, Rev. W. E., *White Colne, Halstead, Essex*—Producer.

The Jubilee Almanack, for A. D. 1851: printed in gold on vellum, with poetical illustrations, in a frame and glazed.

187 RAMSAY, ROBERT, 2 *Greenside Place, Edinburgh*—Designer and Executor.

Specimen of ornamental typography, composed of marble borders, rules, &c., forming a front view of Free Church College, Edinburgh.

188 WASON, RIGBY, M.P., *Corwar, near Givran, Ayrshire*
—Designer.

Plans, showing the method of reclaiming waste land; on a new principle, applied by Rigby Wason, Esq., between the years 1840 and 1850, to an estate of about 4,000 acres, formerly a wild moor without any road, and with only a few patches of cultivated land surrounding the house; it now bears excellent crops of corn and grass, and will, in a few years, be all reclaimed.

189 BARKER, J.—Inventor.

Casts from wood matrices for the use of silk, cotton, and other printers.

190 MEEK, G., 2 *Crane Court, Fleet Street*—Manufacturer.

Ornamental perforated papers, representing lace and crochet work.

191 TAPPERELL & INNES, 2 *Winchester Street, Old Broad Street, and Queen's Arms Hotel, Cheapside.*

Ancient map of the Cities of London and Westminster, and the adjacent districts, as they appeared in the early part of Queen Elizabeth's reign. In this ancient map and drawing, the palace of Westminster, the government and public edifices, &c., are very clearly indicated.

192 WHITBREAD, JOSIAH, 142, *Oxford Street*—Proprietor.

New plan of London, drawn from authentic surveys, on a scale of 3 inches to a mile.

193 RUFF & Co., 2 & 3 *Hind Court, Fleet Street*—Producers.

Map of London and its environs, in six sheets, on a scale of 8 inches to the mile, showing the division of parishes, &c.

194 RICKMAN, WILLIAM CHARLES, 21 *Park Side, Hyde Park Corner, and Pole Hore, Wexford*—Inventor and Designer.

Portfolio bracket, for the purpose of holding portfolios of drawings, prints, &c., and exhibiting their contents to advantage. It is attached to the wall, and is made to open and shut: carved in grenadillo wood.

195 BESLEY, ROBERT, & COMPANY, *Fann Street, Aldersgate Street*—Manufacturers.

Specimens of printing types. A complete series of Elizabethan or church text, with initial letters of the Tudor period. Typographical ornaments taken from the remains of Nineveh and Etruria, court hands, Persian, Syriac, and Arabic.

Modern type-founders' mould and matrix, with types attached.

196 BARRITT & Co., 173 *Fleet Street*—Producers.

Specimens of ecclesiastical binding:—

Royal folio Bible, carved wood boards, covered with Turkey morocco, without cut or join; metal ornamental mountings.

Royal folio Common Prayer, polished oak boards, ornamental metal hinges, and clasp (the hinges and clasp produced by electrotype).

Imperial quarto Bible, Gothic oak boards.

Imperial quarto Bible, carved wood boards, covered with Turkey morocco, without cut or join.

Royal quarto altar service, ultramarine border to pages, carved wood boards, covered with Turkey morocco; corners and centre metal mountings, produced by electrotype.

Royal quarto altar service, velvet; Gothic metal mountings, produced by electrotype.

Sundry small Common Prayers and Church Services, perforated and engraved; solid metal covers, &c.

197 PITMAN, ISAAC, 5 *Nelson Place, Bath*—Inventor.

Chart of the phonographic and phonotypic alphabets.

The Bible, &c., printed phonetically, and the Testament in phonetic short-hand.

[The phonographic or phonotypic systems have this peculiar principle, that words are written and printed as they are pronounced. Since pronunciation differs with districts, it appears difficult to decide upon a standard, and if decided upon by one district exclusively, then the phonographic system becomes exposed to more objections than the ordinary orthography.—R. E.]

198 SOCIETY FOR TEACHING THE BLIND TO READ,
Avenue Road, Regent's Park—Proprietors.

Embossed books for the blind. The characters which have been made use of for letters are raised above the surface of the paper, so that the sense of touch may supply the want of sight. These characters, which are represented in the annexed cut, are simple in their form, being a straight line, a curved line, and a dot placed in different positions; by this means the complication of strokes in the letters of the alphabet is avoided, and the pupils are enabled with ease to distinguish one letter from another.

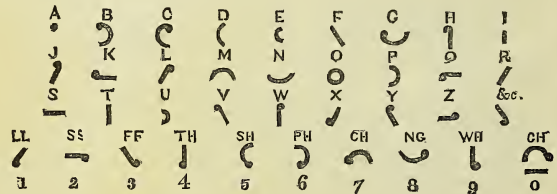

As the finger cannot pass over a word so rapidly as the eye, greater fluency is secured by the use of contractions similar to those employed in short-hand writing. Many who have lost their sight in advanced life, and whose sense of touch has become less acute from hard work, have been enabled to read this simple alphabet, when they have found it impossible to distinguish more complicated characters. An adequate knowledge of the system can be acquired by a pupil in six months, and by many in a shorter period. The system was proposed by the late Mr. Lucas, of Bristol, and was reduced to practice by the Rev. J. W. Gowing, in the year 1842, under the direction of the London Society for teaching the blind to read. The greater portion of the Scriptures, with the liturgy of the Church of England, and various books of elementary instruction, have already been published in these characters.

Cyphering boards for the blind. The boards being perforated with square holes, types with simple characters raised in their ends can be arranged in any order. Five characters similar to those employed in reading are used in different positions, each having a numeral value.

Maps for the blind. The land is raised above the water, and cities, mountains, rivers, and boundary lines are all marked so as to be easily felt.

Geometrical boards for the blind.

Specimen of embossed copies, used for instructing the pupils in the common system of writing, the paper used being prepared with embossed lines.

Apparatus for enabling the blind to emboss Lucas's characters, and thus communicate with each other. The characters are raised on a stamp, having ten arms, fitting into the aperture of a slide so that the letters cannot be incorrectly formed; this slide moves along a bar, and indicates, by means of a rack, the distance it has been moved. The lines are kept equidistant by the bar which moves down the board, which is retained in its position by a simple contrivance.

A specimen of music for the blind, in raised characters, each character denoting both the sound and its length,

whereby the stave is dispensed with. The music can be written by means of the embossed copies.

Chess boards for the blind. The black squares are raised, and the pieces have pegs to fasten them in the board. The black pieces are distinguished by a point at the top. The last three articles were invented by Mr. W. Wood.

Specimens of basket work and knitting done by the pupils at the Institution, Avenue Road, Regent's Park.

[The invention of characters in relief was among the earliest measures resorted to for the instruction of the blind. Mr. Gall, of Edinburgh invented an alphabet upon this principle, called "the triangular." Moveable letters, placed in grooves, were afterwards employed, but abandoned. A string alphabet, like the "quipos," or knotted cord of Peru, for distant communication, was proposed. Various other attempts for this purpose were made, until Haüy invented the art of printing in relief; this was then applied to Mr. Gall's triangular alphabet. By the system of Mr. Lucas the repetition of numerous letters is avoided; simple characters are used; particles are mostly represented by initial letters, a system which is followed upon the frequent repetition of a word.—R. HE.]

199 GARDNER, W. H., *Troy House, Manningtree, Essex*—Designer and Executor.

Specimen of penmanship.

200 ANDERSON, DUNCAN, *Glasgow*—Proprietor.

Napoleon in his Robes, from the lithograph of the engraving of Gerard's picture.

Rubens' Watering-place, from the engraving.

Philip baptizing the Eunuch, from Browne's engraving of Both's picture.

All copied with a common pen, in China ink, by Joseph Lindsay, a deaf mute, and pupil of the Glasgow Institution for the Education of the Deaf and Dumb.

201 BRITISH AND FOREIGN BIBLE SOCIETY, *Earl Street, Blackfriars*—Producers.

Specimens, consisting of 165 books, in different languages, from the 170 versions of the Holy Scriptures, either in whole or in part, which have been published directly or indirectly by the Society, and of which 118 are from translations never before printed; and of which more than twenty-four millions of copies have been circulated since its institution in 1804.

Eight specimens of four editions of the English Bible, showing the improvement made between the years 1816 and 1851, in reference to quality of paper, printing, and binding, at an average reduction of 62 per cent. in the cost price.

Western Europe.

English Bible.
Welsh Bible.
Gaelic Bible.
Irish Bible (Vernacular).
Irish Bible (Roman).
Manks Bible.
French Bible (Martin).
French Bible (Ostervald).
French Bible (De Sacy).
Breton Testament.
French and German Testament and Psalms.
French and English Testament.
French Basque Testament.
Spanish Bible (Scio).
Catalan Testament.
Spanish Basque, St. Luke.
Spanish Gipsy, St. Luke.
Judæo Spanish, Old Testament.
Judæo Spanish, New Testament.
Spanish and Latin Bible.
Portuguese Bible (Pereira).
Portuguese Bible (Almeida).

Northern Europe.

Icelandic Bible.
Swedish Bible.
Lapponese Testament.
Finnish Bible.
Danish Bible.
Faeroese and Danish St. Luke.
Quanian or Norwegian Lapponese Testament.

Central Europe.

Dutch Bible.
Flemish Bible.
German and Hebrew Old Testament.
Lithuanian Testament.
Samogitian Testament.
Polish Bible (Roman).
Polish Bible (Gothic).
Upper Wendish Testament.
Lower Wendish Testament.
Bohemian Bible.
Hungarian Bible.

Central Europe—continued.

German Bible.
Hungarian Wendish Testament and Psalms.

Southern Europe.

Italian Bible (Diodati).
Italian, with Latin Psalms.
Latin Bible.
Romanese New Testament.
Enghadine New Testament.
Piedmontese New Testament.
Piedmontese with Italian, Psalms.
Piedmontese with French, St. Luke and St. John.
Vaudois with French, St. Luke, and St. John.
Bulgarian Testament.
Greek New Testament (Ancient).
Greek Bible (Modern).
Greek with Latin, Testament.
Turkish Bible.
Turkish Bible (Greek characters).
Turkish Testament (Armenian character).
Wallachian Testament.
Servian Testament.
Albanian with Modern Greek, New Testament.

Russia.

Russian Testament (Modern).
Slavonic and Modern Russia New Testament.
Dorpat Esthonian New Testament.
Revel Esthonian New Testament.
Lettish Bible.
Sirenian St. Matthew.
Mordvinian New Testament.
Tscheremissian Gospels.
Tschuwashian Gospels.
Orenburgh Tartar Testament.
Karelian St. Matthew.
Turkish Tartar Pentateuch and Joshua.

Caucasian and Border Countries.

Georgian New Testament (Ecclesiastical).
Georgian New Testament (Civil).
Armenian Testament (Ancient and Modern).
Armenian Testament (Ancient and Ararat).
Armenian Testament (Modern).
Ararat and Modern Armenian Testament.
Trans-Caucasian Tartar St. Matthew.
Armenian Testament (Ararat).
Armenian Psalms.

Semitic Languages.

Hebrew Old Testament.
Hebrew New Testament.
Arabic Bible.
Judæo Arabic, four books of New Testament.
Syriac Bible.
Syriac and Carshun Testament.
Carshun Testament.
Syro Chaldaic Gospels.

Persia.

Persic Testament (Martyn).
Persic Old Testament (Glen).
Judæo Persic, four Gospels.
Pushtoo Testament.

India.

Sanscrit Gospels and Acts.
Hindustani Testament (Roman).
Urdu Persian, portions of Old Testament.
Urdu Persian, Gospels and Acts.

Northern and Central India.

Bengalee, portions of Old Testament.

Northern and Central India—continued.

Bengalee and English, Matthew and John.
Bengalee Testament (Roman).
Bengalee, with English Testament (Roman).
Uriya Bible.
Hinduwee Old Testament.
Harrottee Testament.
Bikanera Testament.
Moultan Testament.
Punjabee Testament.
Cashmerian Testament.
Nepaulsee Testament.

Southern India.

Telinga Testament.
Canarese Bible.
Tamil Bible.
Malayalim Testament.
Tulu Testament.
Kunkuna Testament.
Mahratta Testament.
Punjabee Testament.
Cutchee St. Matthew.

Ceylon.

Pali Testament.
Singalese Bible.
Indo-Portuguese Testament.

Indo-Chinese Countries.

Assamese Testament.
Khassee St. Matthew.

Chinese Empire.

Chinese Bible.
Chinese, St. Luke and Acts.
Manchoo Testament.
Mongolian Old Testament.
Mongolian New Testament.
Calmeuc Gospels, &c.

Hither Polynesia.

Malay Bible (Roman).
Malay Bible (Arabic).
Malay Testament (Low).
Javanese Testament.
Dajak Testament.

Further Polynesia.

Tahitian Bible.
Rarotonga Testament.
New Zealand Pentateuch.
New Zealand Joshua and Psalms.
New Zealand Testament.
Malagase Genesis and New Testament.
Samoan Testament.
Feejeean Testament.

Africa.

Coptic with Arabic, Psalms.
Coptic with Arabic, Gospels.
Ethiopic Testament.
Amharic Bible.
Berber St. Luke.
Bullom St. Matthew.
Mandingo St. Matthew.
Accra St. Matthew and St. John.
Yoruba Romans.
Namacqua, St. Luke.
Sechuana Testament and Psalms.
Caffre Testament.
Sesuto Gospels.

America.

Greenlandish Testament and Psalms.
Esquimaux Pentateuch and Joshua.
Mohawk, St. John.
Chippeway, St. Matthew.
Creolsee Testament.
Negro Dialect of Surinam, Testament and Psalms.
Esquimaux Testament.
Aimara with Spanish, St. Luke.
Mexican St. Luke.

202 HARRISON, ARTHUR PRICHARD, *190 Western Road, Brighton*—Designer.

Framed arms, printed and stained in blazonry colours, granted as hereditary bearings to the nobility by King Henry III., dated 1245. Roll of arms granted as heredi-

tary bearings to the knights companions at the siege of Karlaverock, by Edward I., 1300. Roll of arms granted by King Richard II. to his nobility, dated 1377. Roll of arms of all the Knights of the Garter, from their instalment; plates and ancient records in St. George's Chapel and Windsor Castle. Tournament roll of King Henry VIII., A.D. 1510. Fac-simile of Magna Charta, with arms of the barons, &c., dated 1214. Death warrant of King Charles I., and of Mary Queen of Scots. Fac-simile of illuminated prayer by Henry VII. Genealogy of sovereigns of England, with arms.

203 BELL, Major G., 17 Cecil Street, Strand—Inventor.
Tabular presentment of universal, historical, literary, and artistical time, extending over a surface of nearly 4,000 years, in 25 diagrams.

204 STRANGEWAYS, JOHN, 18 Harpur Street, Red Lion Square—Producer.
New chart of British biography, from the commencement of the 15th century to the present time.

205 ROYSTON & BROWN—Inventors.
Specimens of bank-notes and bills of exchange, engraved by a patent process, to prevent forgery. Various account books.

206 WALTON, T., King Edward VI. School, Birmingham—Producer.
Outline chart of general history.

207 CLEAVER, WILLIAM JONES, 46 Piccadilly—Designer.
Oak and glass case, containing an assortment of Bibles and books of Common Prayer, and a selection of other

books in ancient and modern bindings. Exhibited for the colours of the leather, general design, and workmanship.

208 SPIERS & SON, Oxford—Designers and Manufacturers.
Envelopes and paper, embossed in colours, from college and other dies.
Models of six cathedrals, Osborne House, Martyrs' Memorial, Oxford, &c.

210 WATSON, WILLIAM, 8 George Street, Pocklington—Producer.
Plan of the town of Market Weighton, East Riding, Yorkshire.

211 COMMITTEE OF THE NATIONAL SOCIETY FOR PROMOTING THE EDUCATION OF THE POOR—Depositary, Sanctuary, Westminster.
Specimens of new maps of British geography, models of school apparatus, reading lessons, &c.

212 HARRISON & SON, St. Martin's Lane—Printers.
Specimen of the cuneiform character used in the Babylonian inscriptions discovered by Mr. Layard, now in the British Museum. The first perfect fount of this complicated type ever cast in moveable and combining pieces. Designed and cut by the exhibitors.

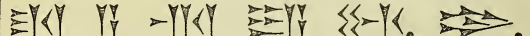
Darius, rex.



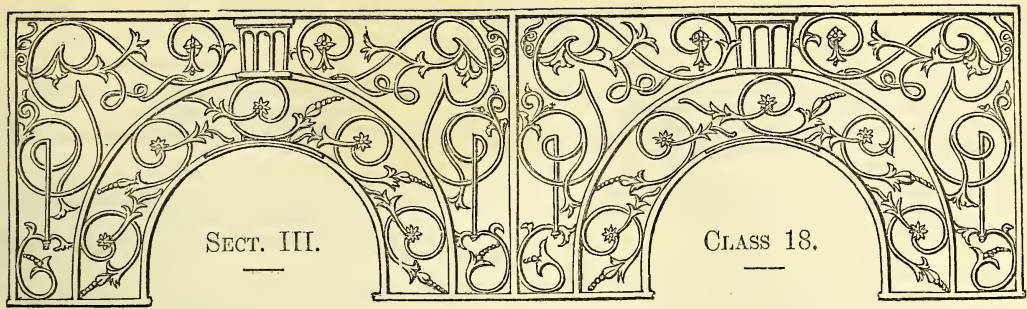

WOVEN, FELTED, AND LAID FABRICS, DYED AND PRINTED.

INTRODUCTION.

THE arts of the colour-printer and dyer form the subject represented by this Class. These arts have made most important progress during late years. At first, taught only by a long and varied experience, the imparting of colour was restricted to the use of a few comparatively simple substances for the extraction of colour, and its application to various fabrics. But since chemistry has been allowed to occupy a part of the attention of the manufacturer, a very different result has arisen. The indications of experience are confirmed by the teachings of philosophy, and in a large number of instances a vast economy of material, time, and labour, has been effected. In addition, chemistry has brought to light new compounds, and new means of obtaining dyes and colours of great brilliance from a few simple combinations. It is consequently now almost universal to find that attached to the extensive works of the dyer and colour-printer, is a large laboratory fitted up for chemical investigations, and the processes developed in which are often the source of very great commercial prosperity.

This Class includes Woven, Spun, Felted, and Laid Fabrics, when exhibited as specimens of printing or dyeing. In the Sub-Class A. are included the Printing or Dyeing of Woollen or any Mixed Substances; B. Includes Printed Calicoes, Cambrics, Muslins, Velvet, and Velveteens; C. Dyed Cotton Goods; D. Dyed Linen Goods; E. The Dyeing or Printing of Leather, Hair, Fur, &c.

The special part of the Building devoted to objects in this Class is that included by Areas L. M. and N. 2 to 5, and O. 3 and 4. But throughout the Building specimens of the art of the dyer in the production of the most rich and beautiful colours are presented in objects which appear, properly, in other Classes. The Turkey-red calico and cloth employed in its decoration, and in the indication of its various departments, avenues, &c., form an interesting instance of this kind.

The print-works of Lancashire, and particularly of Manchester and its vicinity, form the most extensive sources of printed and dyed articles. Glasgow, Carlisle, Crayford, Paisley, and other places, also contain important works of a somewhat similar description. The origin of cotton printing appears to have taken place in the vicinity of the metropolis in 1675.

During the last half-century, a surprising development of printing in colour and dyeing has taken place. It is estimated that at its commencement the annual quantity of cotton printed was 32,869,729 yards. But in 1830, this quantity had attained the enormous increase of 347,450,299 yards; and it has since still further increased. The print-works of Lancashire, and other places, form a surprising spectacle of the operation of chemical and mechanical processes on the great scale. That which was formerly the labour of weeks, is now performed in a day. A piece of cloth is printed at the rate of hundreds of yards in a day. On one side of a machine-room it ascends moist, with colour from the engraved copper cylinder; on the other it descends dried, ready for the final processes. The printing machines are marvels of ingenuity: the pattern is applied by the engraved surface of one or more copper cylinders, which have received the pattern from a small steel cylinder, or "mill," capable of impressing several with the same design, and thus saving the cost of repeated engraving. At first only one colour could be applied; now from six, or even eight and ten colours, are applied in constant succession. These machines perform their work with great accuracy and speed, and produce all the commoner patterns seen in daily use; but hand labour is still employed, even in these works, for fine or complicated work, and more particularly for printing mousseline-de-laine dresses, &c. The goods thus printed are exported in immense quantities to all parts of the world, a large portion being also retained for home use. For foreign countries a certain peculiarity of chromatic arrangement is necessary, in order to render the articles adapted to the taste of purchasers.

The art of the dyer in towns is a manufacture on a smaller scale, and carried on generally in small establishments devoted to that purpose. But extensive dye-works exist, which are employed in imparting various colours to cloth, &c., on the great scale. To the prosperous pursuit of either of these arts, it is beginning to be more and more widely felt, that an enlightened and philosophical mind is of the first consequence. And the number, extent, and importance of many of the establishments where they are extensively carried on, is a gratifying indication of the present position of those who are occupied in such pursuits.—R. E.

- 1 EVANS, DAVID, & Co., 121 *Cheapside*, and *Crayford, Kent*—Manufacturers and Printers.
Bandanna handkerchiefs, manufactured in India.
British bandannas, manufactured at Macclesfield, from Bengal and China silk.
Spun bandannas, manufactured in Lancashire.
Ladies' silk dresses. Table covers.
Registered designs.
- 2 BAKER, TUCKERS, & Co., 30 & 31 *Gresham Street*—
Silk Manufacturers and Printers.
British and East India silk handkerchiefs and dresses, printed in London. Registered designs.
- 3 LIDDARD & Co., *Friday Street, Cheapside*—
Manufacturer.
Printed mousseline-de-laines, barèges, &c.
- 4 INGLIS & WAKEFIELD, *Busby Print Works, near Glasgow*—
Manufacturers.
Printed mousselines-de-laine on cotton warp; printed cashmeres, balzarines, cottons, and jaconets; the dahlia, a patented colour. The designs are all registered.
- 5 ANDREWS (HUGH), SONS, & GEE, 55 *Friday Street*—
Producers.
Printed cotton, muslin, woollen, and mixed fabrics.
- 6 DEVAS, MINCHENER, & ROUTLEGE, 24 *Lawrence Lane*—
Proprietors.
Specimens of printed cambrics and muslins, exhibited as cheap and useful productions for the middle class.
- 7 WELCH, MARGETSON, & Co., 17 *Cheapside*—
Manufacturers.
A selection of silk handkerchiefs, manufactured from China silk, and India corahs, printed by the exhibitors.
Printing blocks for the purpose of shewing the process of Bandanna printing.
- 8 WILKINSON, WILLIAM, 89 *Watling Street*—
Manufacturer.
China cord "pongee" handkerchiefs, and China and grey twilled bandannas, British manufacture. India corahs, specimens of madder red, cochineal, crimson, and other courses of work. Specimens of printed and dyed work, in various stages of manufacture.
- 9 SWAN & EDGAR, *Picadilly, and Regent Street*—
Proprietors.
Spitalfields silks, velvets, &c., manufactured by J. Balance & Sons, Stone & Kemp, and Winkworth & Procters.
Printed muslins, butterfly, rose and convolvulus patterns. Printed by Hargreaves Brothers.
- 10 LAW & SONS, 37 *Monkwell Street*—Manufacturers.
Embossed silk and velvet.
Specimen of cloth used for bookbinding.
Embossed velvet and furniture-linings for decorations.
Embossed grounds for paper-hangings.
- 11 CROCKER, J. & A., 51 *Friday Street*—Manufacturers.
Harness woven muslins for curtains. Complete drapery, blind and curtains of harness woven muslin, showing its adaptation for window decoration.
Printed cotton for furniture uses; the colours produced by machine, and by a combination of machine and block-printing.
- 12 KEYMER, JAS., *Lawrence Lane*—Producer.
Silk bandanna handkerchiefs in needlework style, flowers, small or Fichus; and a study, commemorative of the Great Exhibition. Printed at the works of Augustus Applegath, Dartford.
- 13 MAIR, SON, & Co., 60 *Friday Street, London*, and 163 *Ingram Street, Glasgow*—Manufacturers.
Twilled bandannas and cambric handkerchiefs.
- 14 McALPIN, STEAD, & Co., *Cummersdale, Carlisle*—
Designers and Printers.
Machine and block chintz furnitures, upon cotton velvet and calico.
- 15 HINDLEY, C., & SONS, 134 *Oxford Street*—Designers and Manufacturers.
Printed chintz furniture: original designs, English production.
- 16 FOSTER, PORTER, & Co., 47 *Wood Street, Cheapside*—
Manufacturers.
British and East India silk handkerchiefs, printed in London.
Block employed in printing handkerchiefs.
Silk, thread, woollen, leather, and silk-plush gloves.
Bandannas. Parasols. Ribbons. Fancy hosiery—polka jackets, gaiters, hoods, hose, &c.
- 17 WILSON, —, Producer.
Specimens of cloth for bookbinding.
- 18 WELCH, THOMAS, *Merton Abbey, Merton*—
Manufacturer.
Printed cloth drawing-room table-covers, of various designs and colourings.
Embossed cloth drawing-room table-covers, different designs and colourings.
- 19 WALFORD, RICHARD, 27 *Lawrence Lane*—Proprietor.
Printed silk handkerchiefs. East India silk manufacture, printed in England.
- 20 JOHNSON, R. J.—Producer.
Specimens of dyed goods.
- 21 SWAINSON & DENNYS, 97 *New Bond Street*—Designers and Printers.
Chintzes for dining-rooms, libraries, &c. Chintz, imitation of drapery, for wall-hangings, curtains, &c.; of tree, flowers, drab leaves, &c.; of group of flowers and ribbon; of the acacia; of group of flowers in rustic panel; and of birds and flowers, for drawing-room curtains, &c. Chintzes suitable for bed-furniture, &c., 26 inches wide.
- 22 UNDERWOOD, WILLIAM, 1 *Yere Street, Oxford Street*—
Manufacturer.
Printed cloth table cover, commemorative of the Great Exhibition. This table-cover is represented in the accompanying Plate 37. The printing of this cover has taken 223 blocks and copper-plates. In the centre are the arms of Great Britain, surrounded by those of the principal nations of the globe, with suitable inscriptions.
- 23 CLARKE, ENOCH, *Neate Street, Coburg Road, Old Kent Road*—Manufacturer.
An assortment of printed and painted japanned table-covers.
- 24 YATES & TAYLOR, 42 *Gutter Lane, Cheapside*—
Manufacturers and Proprietors.
Printed and embossed table-covers, for ornamental table furniture. Shaded style of work, giving a velvet-like appearance, similar to needlework, from one impression.
- 25 THOMSON BROTHERS & SONS, 1 *Mosley Street, Manchester*—
Producers.
Printed cambrics and mousseline de laines, cotton warps, shot silk, and worsted; printed cambrics, &c., silk warps, shot silk.
- 26 BURD, JOHN, & SONS, *Manchester*—Printers.
Machine-printed calicoes, madder and steam colours.
Block-printed calicoes, steam colours.
Machine-printed muslins, madder and steam colours.
Block-printed window blinds.
Printed quilts.

UNITED STATES
FRANCE

TURKEY SPAIN GREECE

RUSSIA
ASIA

HANOVER
NETHERLANDS
BELGIUM
WURTEMBERG

SARDINIA
PAPAL STATES
SWITZERLAND
SICILY

AUSTRIA
BRAZIL

SAXONY GREAT BRITAIN BAVARIA
DENMARK
SWEDEN

PRUSSIA
AFRICA



- 27 DALGLISH, FALCONER, & Co., *Lennox Mills, Lennoxtown, Stirling*—Printers.
Calico prints and muslin prints.
- 28 THE STRINES PRINTING COMPANY, *Manchester*—Producers.
Specimens of machine printing on cotton velvet; eight colours, produced by one operation, at the rate of sixty yards per minute.
The same on calico; eight colours. Steam work.
Specimens of madder work.
- 29 NELSON, KNOWLES, & Co., 11 *George Street, Manchester*—Printers.
Calico and mousseline-de-laines, crimson ground style. Coloured steam printing.
Chintz furniture showing fourteen colours, chintzes and other prints, all the colours printed at one time by cylinder.
- 30 POTTER, E., & Co., *Dinting Vale, Glossop, and Manchester*—Producers.
Variety of calico prints; moderate in cost, adapted for a variety of markets, and produced by machine throughout.
- 31 SAMUELS, JOHN, & Co., *Manchester*—Manufacturers.
Black and Turkey-red velvet. Black velveteen. Drab moleskin. Drab eight-shaft cord. Black satins. Printed drills. Albert tweeds. Moleskins. Holsteins. Velveteens. Waldemars. Furniture velveteens. Mock quiltings and herring bones. Diamond and welted quiltings and satins.
- 32 RAMSEY, CHARLES, & Co., *Manchester*—Proprietors.
Dyed and printed cotton trouser cloth, in imitation of woollen; possesses the appearance and durability of woollen cloth.
- 33 BANNERMAN, HENRY, & SONS, *Manchester*—Producers.
Patent cloth used for upholsterers' purposes, as curtains, &c., so produced that they will not tarnish.
Cloth suitable for ladies' dresses, gentlemen's coats, bindings for books, and embellishments of various kinds.
- 34 BAYLEY & CRAVEN, 61 *Mosley Street, Manchester*.
Calico prints, fast lilacs, madder colours; chocolate ground, garancine work; and two and three coloured madder works.
Sample of a new "resist" purple, that will throw off chocolate, dark purple, catechu, brown, or red grounds.
- 35 SWANWICK & JOHNSON, *Manchester*—Producers.
Printed calico and printed muslin.
- 36 HOYLE, THOMAS, & SONS, 58 *Mosley Street, Manchester*—Manufacturers.
Printed calicoes, black, purple, and whites; light purples and brunettes, &c.
Printed cambrics, in all colours, suitable for children, and large patterns for dresses.
Printed muslins. Checked and plain jaconets.
Printed mousseline-de-laines and llamas, both mixed fabrics.
[Machine-printing is performed in the following manner. The fabric is drawn by power over one or more engraved copper cylinders, the lower part of which revolves in a trough containing the colour. By an ingenious arrangement, a blade of steel, or other metal, called a doctor, removes the superfluous colour, leaving only the indentations on the cylinder charged therewith. The pressure to which the fabric is subjected causes it to absorb this colour, and it is then carried upwards into a room at a high temperature where it is dried, and returns to undergo further processes of preparation. At first, only one coloured pattern could be communicated to the fabric, but now seven or eight cylinders are not unfre-

quently used in the same machine, each applying a different colour to the fabric as it passes forward, and each so adjusted as to cause the colour to fall precisely in the proper place, so as to complete the pattern. Machine-printing is carried on to an enormous extent in Manchester.—R. E.]

- 37 STEINER, T., & Co., *Church, near Accrington, Manchester*—Manufacturers and Inventors.
Cotton fabrics, dyed Turkey-red and printed in various colours.
- 38 LEDDIARD & Co., *London*; HARGREAVES BROTHERS, & Co., *Manchester*—Manufacturers.
1. A butterfly chintz muslin, displaying a combination of permanent colours.
 2. A rose trail chintz muslin, in permanent colours, in three varieties of ground.
 3. A moss-rose chintz, upon orgardie muslin.
 4. A bouquet chintz, on two varieties of ground, with combination of permanent colours, by Mercer's patent process.
 5. A design of one-block printing, exemplifying, by a variety of coloured grounds, the nature of Mercer's patent process, with the ordinary colours.
 6. The same design printed by the ordinary processes and colours.
 7. A design upon lobelia crimson ground, showing a new application of safflower for dyeing or for printing purposes, where white is not required, uniting permanence with brilliancy of colour.
 8. Lobelia crimson plain muslin.
 9. Lobelia crimson plain cotton satin.
 10. Lobelia crimson and other dyed cotton velvets.
 11. Silver dove, a new mineral colour, not liable to be injured by the influence of air or light.
 - 12, 13, and 14. Designs upon various shades of permanent plain cotton muslins.
 15. A demi-chintz upon muslin, in three varieties.
 16. A second design of the same class.
 17. A design upon white figured muslin, in three varieties.
 18. A second design of the same class.
 19. A chrysanthemum chintz upon cotton satin in two varieties.
 20. A bouquet chintz, in permanent colours, in two varieties; upon cotton satin.
 21. A moss-rose chintz, of similar class and materials.
 22. A rose-bud chintz, of the same class and material.
 23. White sprigs upon black cotton washable satin.
 24. An Indian chintz, printed in permanent colour, upon Horrocks's long-cloth.
 25. A full chintz, also printed on the same.
 - 26, 27. Designs, showing Mercer's patent process for colours applied to machine printing.
 - 28, 29, and 30. Designs, produced by the usual method of machine printing and the usual processes, in three varieties.
 - 31, 32, and 33. Designs, to show Mercer's patent process applied to another style of machine printing.
 - 34, 35, and 36. Designs, to show the ordinary colours used in machine printing, in four varieties.
 - 37, 38, and 39. Designs in the floral style of machine printing, in two varieties.
 - 40, 41, 42, and 43. Designs in the foliage style of machine printing.
 - 44, 45, and 46. Floral designs in the same style.
 47. A bouquet chintz, upon silk material.
 48. The same design upon silk, cotton, and wool, united, by Lightfoot's patent Duplin process.
 49. A butterfly chintz, upon the same material, and by the same process.
 50. A design, upon silk, in two varieties.
 51. A bunch of lilac, a design printed upon pure wool.
 52. The same design upon a cotton and wool mixed fabric, by Lightfoot's process.
 53. The same, upon cotton, silk, and wool united, also with same process.

54. A larger lilac blossom design, printed upon pure silk.

55. The same design upon cotton, silk, and wool, mixed fabric, by Lightfoot's process.

56. A robe skirt of a graduated design, assisted by graduated rainbow printing upon pure silk.

57, 58, and 59. The same design printed upon mixed fabrics of cotton and wool, by Lightfoot's process.

60. An Indian chintz, design upon pure wool.

61. The same design upon mixed fabric of cotton and wool.

62. A full chintz, effected by only two block printings, upon a mixed fabric of cotton and wool.

[Formerly the application of coloured designs to fabrics of various kinds was entirely effected by what is called block-printing, and which, in fact, closely resembles type printing. A block of wood or metal, or a combination of both, being engraved with the pattern, received the colour by the ordinary means, and this was then transferred by hand to the fabric. For every different colour a different block was required, and in complicated patterns, with many colours, the process was excessively tedious. It is, however, still largely employed where great care in the application of the colour and sharpness of definition in the pattern is required, but block-printing can only be remunerative in the better descriptions of goods, as the infinitely more rapid and economical process of cylinder printing has almost superseded it for the production of those of commoner kinds.—R. E.]

39 SALE, JOHN NICHOLAS, *Manchester*—Producer.

Collection of shirtings, printed by machine. Collection of cottons, printed by machine and block.

Specimens of Irish linen, bleached, printed, and finished by the exhibitor.

40 BRADWELL & ADAMS, *Ardwick, Manchester*—Producers and Designers.

Printed velveteens, in different colours; design, a memento of the late Sir Robert Peel, Bart.

41 SALIS, SCHWABE, & Co., *Manchester*—Producers.

Printed cotton cambrics, or calicoes. Printed cotton muslins.

42 BENECKE, WILLIAM, & Co., *Manchester*—Producers.

Printed calicoes, muslins, furnitures, and velvets; and warps, after printing, manufactured by Thomas Knight & Co., *Manchester*.

43 ANDREWS, WILLIAMS, & Co., *Tipping Street, Ardwick, near Manchester*—Producer.

Specimens of Kesselmeyer and Mellodew's patent cotton velvet, as dyed by the exhibitors.

44 KESSELMAYER & MELLODEW, *23 Cooper Street, Manchester*—Inventors and Manufacturers.

Patent velvets and velveteens, partly manufactured of cotton, and partly of cotton warp and linen weft, dyed and padded, various colours, and finished in imitation of silk velvet. Cotton velvet and velveteen of the old make.

45 WOODCROFT, JOHN, & Co., *Salford*—Printers.

Velvet and velveteen. Cable cord. Fancy elastic hair cord. Beaverteens. Satintop. Diagonal tweed. Constitution cord. Fancy cut thickset cords, and tabby cord.—All grey as from the loom, and specimens of each printed in various patterns and colours.

46 GREENWOOD & BARNES, *Irwell Springs, Bacup*—Dyers.

Fancy cotton muslins, dyed Turkey red; varying only in pattern.

47 SIMPSON & YOUNG, *Foxhill Bank, Accrington, and 23 Mosley Street, Manchester*—Producers.

Balzarines, barèges, and mousseline-de-laines, mixed fabrics, and muslins of cotton texture, in various combinations of colourings; printed by machine.

Cambrics in various combinations of colourings, in madder and steam-work, printed by machine.

Cotton velvets, printed by machine.

48 MERCER, JOHN, *Accrington*—Inventor.

Specimens of cotton cloth, printed, dyed, and in different stages of manufacture: prepared by a patent process. This patent consists in subjecting cotton, and other fibrous materials to the action of caustic soda of suitable strength and temperature, whereby the fibres become contracted and fulled, converting thin and coarse cloth into strong and fine; at the same time giving greatly increased and improved powers of receiving colors in printing and dyeing, and also in making them more permanent.

49 MONTEITH, HENRY, & Co., *11 George Square, Glasgow*—Manufacturers.

Specimens of Turkey red yarns and cloths.

Printed handkerchiefs, garments, furnitures, scarfs, and shawls, in Turkey red.

Printed cotton handkerchiefs and shawls, in madder, indigo, and steam colours.

49A CAIRNS, J., *9 Charlotte Street, Manchester*—Manufacturer.

Fancy cotton muslins dyed Turkey red.

50 M'NAIR & BRAND, *Glasgow, and 23 Friday St., London*—Manufacturers.

Printed shawls. Long and square woollen fabrics. Indian styles. Registered designs.

51 BLACK, JAMES, & Co., *Glasgow*—Manufacturers.

Printed cambrics, muslins, mousselines-de-laines, Barèges, and other fancy cotton, woollen, and silk fabrics. The cloth is manufactured chiefly by power-loom, and by hand-loom weavers in the west of Scotland and north of Ireland.

52 GOURLIE, WM., & SON, *8 South Frederick St., Glasgow*—Designers and Printers.

Printed muslins, on plain and fancy fabrics, manufactured for the home and foreign markets. The dahlia, a patented colour. Designs registered by the exhibitors.

53 MONTEITH, JOHN, & Co., *51 Buchanan Street, Glasgow*—Manufacturers.

Printed muslins and jaconets.

Printed mixed fabrics,—silk and wool, and cotton and wool.

54 KERR & McMILLAN, *44 Friday Street, and at Glasgow*—Manufacturers.

Two printed silk pocket-handkerchiefs, exhibited for fabric and design.

55 CUSSONS & Co., *51 Bunhill Row*—Manufacturers.

Cotton velvets, dyed and embossed by the exhibitors.

56 STIRLING, WILLIAM, & SONS, *Glasgow*—Manufacturers.

Specimens of Turkey-red dyeing and printing, on cotton fabrics.

56A BRODIE, W., *Asylum for the Blind, Glasgow*—Producer.

Specimens of work wrought by the female inmates, under the direction of Miss Lamond:—

Silk purses, long and round. Sofa and toilet cushions. Polka jacket. Set of nine fruit mats; set of twelve doyleys. Bread-basket cover. Smoking caps; pair of stockings. Babies' boots and carriage boots.

A part of the Holy Scriptures (the Prophecy of Isaiah) in raised letters, for the use of the blind.

Five-bushel sacks, of first and second quality.—Manufactured by the blind male inmates of the same institution, under the direction of Mr. Semple.

57 EWING, ORR, & Co., *Glasgow*—Manufacturers.

Three pieces of Turkey-red full chintz furniture prints, printed by blocks, exhibited for fast and brilliant colour, and new style, with beauty of design and execution.

Three pieces of Turkey-red chintz prints, printed by cylinder machine.

Two pieces of Turkey-red chintz furnitures, combining fastness and brilliancy of colour with novelty of style and beauty of design and execution.

One piece of Turkey-red handkerchief, printed by discharging-press and copperplate.

One piece of Turkey-red handkerchief, printed by blocks.

[Turkey red, which is represented so largely in this exhibition in the hangings, banners, &c., is a dye derived, by a tedious process, from madder. It appears to have originated in India, but the art is now carried to great perfection by many continental dyers, and by the dyers and calico-printers of this country. Peculiar circumstances, whether in the manipulation or in the material does not appear ascertained, have rendered different localities and manufacturers celebrated for the brilliancy of this dye.—R. E.]

58 WALSHAW, JOHN, & SONS, *North Bridge, Halifax*—
Dyers and Producers.

Specimens of variously dyed two-fold thirties, worsted warp.

59 HITCH, M., *47 High Street, Cowes, Isle of Wight*—
Producer.

Hair, to show the effect of dye.

Wools, showing different dyes applied without fire-heat for dyeing wools and woollen yarns (for weaving cloths, carpets, rugs), and cloths when woven.

Horn, stained without the application of soda or potash, to imitate tortoiseshell, the stains not readily affected by damp or sea-air.

The marone colours, 5, 6, 7, and 8, were produced in 24 hours, and by the application of fire-heat may be produced in 15 minutes from the time of its leaving the scourer's.

60 LE LIEVRE, H., *8 Cleveland Street, Mile End Road*—
Producer.

Specimens of black-dyed silk.

61 JOURDAIN, W. D., *60 Milton Street, Cripplegate*—
Producer.

Coloured and black specimens of silk dyeing.

62 CHABOT, PHILIP J., *Spitalfields*—Producer.

Specimens of English fleecy and worsted yarns, and Berlin wool, cotton and linen yarns and skein-silks, London dyed, in various colours and shades; scarlet and crimson ingrain.

The cotton and linen colours are from a new use of a known colouring matter. The colours from chicory are at present only a novelty.

The above are all from the dye-works of the producer, Spitalfields, London.

63 REYNOLDS, SARAH, & SON, *Temple Street, Hackney Road*—Producers.

Specimens of skein-silk dyeing.

63A MAIR, SON, & Co., *Friday Street, Cheapside*—
Manufacturers and Printers.

Printed flannels.

64 MCCALLUM, *Government School of Design, Manchester*.

Panoramic history of the calico printing of Manchester, comprising specimens of the trade since its rise and during its progress to the present time, arranged in chronological order, and illustrated by views in and about Manchester.

Designs with Classes 5 and 6 on the North Wall, Avenues 28, 29, and 30.

64A BRADBURY, GREATOREX, & BEALL, *Aldermanbury*—
Producers.

Specimens of wood cut printing for pocket-handkerchiefs.

65 CARTER, —, Designer.

Designs for paper-hangings.

66 HUDSON, CHARLES, *Merton, Surrey*—Designer.

Designs for printed shawls.

67 WATERSON, J. A., *22 Ormond Street, Chorlton-on-Medlock*—Designer.

Designs for printed muslins.

68 KAY, HENRY, *Rawtenstall, Manchester*—Designer.

Designs for mousseline-de-laine and cotton muslin.

69 FLETCHER, JOHN, *Altrincham*—Designer.

Design, 11 colours, repeat of sketch, 11 inches by 8 inches.

A smaller design, 9 colours, repeat of sketch, 8 inches by 6 inches, intended for block work.

70 GAUTHORP, —, Designer.

Design for ornamental panel.

70A GREEN, HARRY, *Melbury Park, Dorchester*—Designer.

Designs for printing on calico and mousseline-de-laine.

71 HAMMERSLEY, J. A., *Principal of the School of Design, Manchester*—Designer.

Picture in oil colours, showing the principles upon which floral forms are adapted to designs for textile fabrics; exhibiting a central picture of a composition of flowers, imitated from nature, surrounded by 200 geometrical spaces, each containing a separate design, and showing the mode of applying these flowers to manufactures.

[For textile fabrics, natural flowers have been represented under conventional forms; so that, without departing from the original type, the character of design may not be pictorial. The patterns of Eastern Chintzes are but fantastic imitations of flowers; and the pure taste of ancient Greece discarded from female dress all ornament but that of a flat character: where borders of the vine or ivy-leaf, or of the honeysuckle, have been adopted, they are flat. The oriental Cashmere style, the stuffs and carpets of Persia and Turkey, the Tartan of the Scot, the Arabesques of ancient Rome and Moorish decoration, while admitting of every variety or beauty in design or colour, are examples of a flat, as opposed to a relieved, pictorial style of ornament.—R. HE.]

72 WATERHOUSE, JONATHAN, *Manchester*—Pattern
Designer.

Ornamental design for a dress skirt, applicable for printing upon fabrics.

Coloured designs, arranged for seven-inch repeat of sketch, adapted for machine printing on fabrics: Spring, represented by the snow-drop; Summer, laburnum; Autumn, nasturtium; Winter, misletoe; Morning and Evening, poppy

73 PERCIVAL, JOSEPH, *Manchester*—Designer.

Designs for mousseline-de-laine.

74 CADMAN, —, Designer.

Designs for muslins.

76 WHITTAKER, JAMES, *Manchester*—Designer.
Design for muslin.

77 LENNON, RICHARD, *Manchester*—Designer.
Various designs for muslin.

79 BRIDGES, —, Designer.
Designs for printed fabrics.

81 ROBERTS, T., *New Street, Altrincham*—Designer.
Six five-colour designs for mousseline-de-laine; with block-work enclosed in the same frame.

82 JARVIES, —, *Hulme, Manchester*—Designer.
Designs for printing.

83 HOBBS, WILLIAM, *33 Great Jackson Street, Hulme*—
Designer.
Design applicable for printed chintz furniture.

84 BRAMLEY, —, Designer.
Various designs.

85 REES, MARY, *School of Design, Somerset House*—
Designer.
Designs in various colours.

86 COLLINS, F., *School of Design, Somerset House*—
Designer.
Various coloured designs.

87 ASHWORTH, S. A., *Central Female Government School
of Design*—Designer.
Various designs in colours.

88 MANSBENDEL, FRED., *63 Bread St., City, & 34 Acton
Street, Gray's Inn Road*—Designer.

Chintz furniture design, practically arranged for block printing.

89 SMITH, JOHN, *Sandway, Altrincham, near Manchester*
—Designer.

Designs for a portière, or door-screen; and for machine and block printing on silk, mousseline-de-laine, and cambric.

90 HUNT, J. C.—Designer.
Various designs.

91 HEAVISIDE, JOHN, *30 Bedford Square*—Designer.

Designs for China and papier maché.
Designs for decorative paper and paper-hangings.
Designs for cotton-prints, &c.

92 GLOVER, MARIA, *School of Design, Manchester*—
Designer.

Designs for borders, in which natural objects are applied ornamentally; they may be used for wall papers, carpets, or porcelain.

93 SANDWAY, —, *Altrincham*—Designer.
Various designs.

94 GANN, LOUISA, *School of Design, Somerset House*—
Designer.

Three coloured designs for mousseline-de-laine or calico.



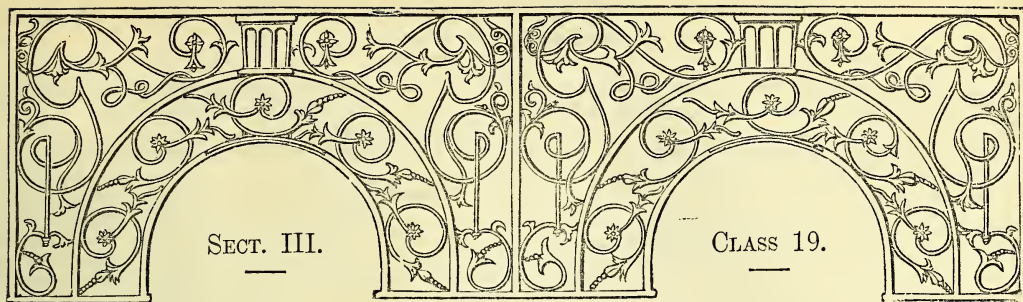

TAPESTRY, CARPETS, FLOOR-CLOTHS, LACE AND EMBROIDERY, &c.

INTRODUCTION.

SOME of the objects included in this Class present, from their remarkable disposition in the Building, a highly attractive and interesting appearance, suspended from the girders over the Galleries, and thus displayed to the best advantage, and under circumstances the most highly calculated to develop their peculiar beauties;—the specimens of carpets, oil-cloths, and tapestry must be considered as occupying a very prominent space in the Exhibition.

The following Sub-Classes have a place under the general Class, inclusive of these and other articles:—A. Tapestry, as Carpets of all kinds, Axminster, Brussels, Kidderminster, &c., Matting, Oil-cloth, Counterpanes, and ornamental Tapestry of different materials; B. Lace, as Pillow-lace, made wholly by hand, and Machine-wrought lace; C. Sewed and Tamboured Muslins; D. Embroidery by hand and machinery, and in different materials; E. Fringes, Tassels, &c.; F. Fancy and Industrial Works.

In the Building, objects in this Class are placed against the wall in the South Gallery, and arranged in cases in the South Central Gallery. Carpets and oil-cloths are suspended from the girders in the Side and Central Galleries, and in the Galleries on the East Side of the Transept. The carpets exhibited by Her Majesty the Queen are placed overhanging the corner near the Transept of the North Central Gallery; of these, one is made in the usual manner, and is intended for an apartment in Windsor Castle; the other is the combined production of one hundred and fifty ladies, and is wrought in Berlin wool-work.

The manufacture of tapestry, such as carpets and oil-cloth, and lace, is localized in peculiar districts, in a remarkable manner; Kidderminster, Wilton, Glasgow, and Halifax contain extensive factories solely engaged in the production of the various descriptions of carpets in ordinary domestic use. The application of the powerloom to the carpet manufacture is recent, and its use is extending. A great variety of combination of materials is exhibited, many of which indicate a remarkable departure from the ordinary method of manufacturing carpets and similar objects. One of these is a species of mosaic tapestry where the cut wool is fixed to a ground or foundation of caoutchouc.

The lace productions of Honiton and Buckinghamshire have long attained universal renown. These laces are chiefly wrought by hand at the homes of the persons concerned in their manufacture; but recently a combination of machine-made lace and pillow-made ornament has been introduced under the title of “appliquée lace.” The machine lace of Nottingham has scarcely an inferior degree of celebrity: in that town factories are in almost constant work producing, by the aid of a large number of the most delicate and costly automatic engines, this slender fabric. In a preceding Class these machines are described, and are exhibited in motion in another part of the Building. In the South Central Gallery are some beautiful specimens of the intricate and elegant ornamentation capable of being imparted by these machines. Of the lace made by hand various interesting specimens are shown which represent much patient effort in the instruction of the poor in this art, and considerable taste of design.

Works which have occupied the unwearied producers during the leisure hours of some years are exhibited in this Class, and display a large amount of industrial perseverance.—R. E.

1 BIDDLE, DANIEL, 81 Oxford Street—Manufacturer.

Specimen of Honiton lace, representing the arms of Her Majesty the Queen and H.R.H. Prince Albert, encircled with wreaths of palm and olive branches, around which the rose, thistle, and shamrock are entwined, and the whole enclosed in a border of oak. Designed by T. Sharp, and manufactured by John Tucker.

Honiton guipure mantle. Bridal scarf and rich flounce in Honiton lace; the pattern composed of natural flowers.

Honiton shawl. Honiton guipure flounce. Flounce of point d'Angleterre, worked in imitation of Brussels point.

Berthe, handkerchief, coiffure, infant's cap and collar of Honiton lace.

Embroidery as a specimen design, for making ladies' handkerchiefs.

2 FISHER & ROBINSON, 12 Watling Street—Manufacturers.

Various samples of black silk lace and piece goods, scarfs, lappets, half shawls, laces, footings, loop nets, white blonde machine-run curtains, white tambour flowerings, black needlework, quiltings, and nets.

3 GROUCCOCK, COPESTAKE, MOORE, & Co., 5 Bow Churchyard—Manufacturers.

Honiton work point lace, guipure berthes, lappets, &c. Embroidered muslin sleeves, collars, chemisettes, muslin trimmings, infants' caps, and child's frocks.

Buckinghamshire lace.

Lace pillow, with lace in progress, employing upwards of 600 bobbins, each having a separate thread.

Specimen of lace net for mosquito curtains, manufac-

tured of cotton thread; and for the application of Brussels and Honiton sprigs, manufactured from cotton thread.

Needlework imitation Brussels point lace, viz.: a dress and train, a scarf, berthe, and lappet.

Victoria prima point lace.

[Few departments of ornamental industry have experienced so many vicissitudes, in consequence of the introduction of mechanical power, as that of the lace manufacture. The lace of Honiton, in Devon, has long rivalled the most beautiful and costly productions of the Continent. At one period during the last war, veils of Honiton lace sold for very large sums, as much as 100 guineas having been paid for fine specimens. Honiton lace is entirely made on the pillow by hand labour.]

4 LAMBERT & BURY, *Limerick, Ireland*—Designers and Manufacturers.

Specimens of lace; shaded lace flounce; shawl; and worked scarf, in imitation of Valenciennes; shaded tunic lace dress.

5 HOWELL, JAMES, & Co., 5, 7, & 9 *Regent Street*—Producers.

Honiton lace, square in guipure.

Honiton guipure lace mantle and berthe.

British point lace berthe, manufactured at Islington, being an imitation of the Brussels point à l'aiguille.

White glacé silk dress, embroidered with bouquets of flowers, and silk apron to correspond, as specimens of English needlework.

Brocaded silk in various colours, forty inches wide, manufactured in Spitalfields.

6 WEEDON, FRANCIS, *Goldsmith Street, City*—Manufacturer.

British point lace square, and specimens of flouncing of the same fabric.

8 NERINCK, SISTERS, 10 *New Cavendish Street*—Manufacturers.

Specimens of lace.

10 LAUGHER & COSENS, 97 *Oxford Street*—Proprietors.

Guipure lace half shawl, manufactured at Honiton.

11 WEEDON, FREDERICK PRICE, 29 *Lower Street—Islington*—Designer and Manufacturer.

A lace berthe of the description of work designated British point.

12 PULLAN, MATILDA, 126 *Albany Street, Regent's Park*—Designer, Inventor, and Manufacturer.

Modern point lace, worked with a common sewing needle.

13 TAWELL, SAMUEL, 16 *Gresham Street West*—Manufacturer.

Tamboured lace scarf, imitation of Honiton, manufactured in London.

14 GOULD, J. & F., 89 *Watling Street*—Manufacturers.

Registered Victoria lace work, in ladies' collars, cuffs, capes, sleeves, caps, and trimming for ladies' wearing apparel. Produced entirely by hand.

15 URLING, GEORGE FREDERICK, 224 *Regent Street*—Manufacturer.

White lace scarf, in imitation of Brussels point, composed of British plants and flowers in needlework; the date, 1851, encircled with the rose, thistle, and shamrock; the straight lines of the border embroidered in gold, and worked upon a fine clear patent net.

16 GARD, WILLIAM SNOWDON, 268 *Regent Street*—Designer and Manufacturer.

British point lace scarf.

British guipure lace berthe, a new manufacture.

17 RIEGO DE LA BRANCHARDIERE, ELEONORE, 106 *New Bond Street*—Inventor and Manufacturer.

Crochet work, lace berthe; design, rose, shamrock, and thistle; the same, with rose, carnation, &c. Robe, medallions. Altar cloth. Couvrette, flowers. Collars, various.

Flounce, imitation of Spanish point lace. Initial letters in silk, flowers. Vase, flowers, butterfly and snake. Cornucopias. Baby's cap.

Design, in silk and gold, for Prayer-book covers. Pair of hand screens, appliqué. Specimens of point, and of point lace.

The value of this branch of needlework lace is its durability, and the facility with which it can be acquired and executed. The designs are registered.

18 CLARKE, JANE, 170 *Regent Street*—Manufacturer.

Royal Irish snow point lappet.

Head dress of Irish rose point.

Scarf of Belfast loop point.

Chalice cover of Irish point.

An Irish lace flounce, with point roses.

Hibernian point collar.

A pocket handkerchief of Irish lace.

19 BALL, DUNNICLIFFE, & Co., *Nottingham*—Manufacturers.

Patent elastic velvet, plain and mixed pile; silk elastic taffeta, silk elastic fleeced taffeta, elastic fabrics, and Simla shawls; all from warp-lace machine. Designed by John Wilkins.

Lace shawls. Simla nets, falls, quillings, and fancy breadths, from bobbin-net machine.

20 BIRKIN, RICHARD, *Nottingham*—Manufacturer.

Black silk lace edgings, trimming laces, lappets, flounces, falls, fancy piece-nets, &c.

White silk blondes.

Woven thread laces and edgings.

White Valenciennes edgings.

An exact imitation of real Valenciennes-insertion, black and coloured.

Mohair laces and flounces.

Guipure à dentelle.

All made and ornamented by machinery, at one operation.

21 ADAMS, SAM., & SONS, *Nottingham*—Manufacturers.

Laces and edgings, made entirely by machinery.

25 HEYMAN & ALEXANDER, *Nottingham*—Proprietors.

Machine-wrought cotton lace curtains, with raised pattern; counterpanes; "antimacassars."

Cotton extra twist Brussels net, made of fine thread, various kinds, used for Brussels sprig.

Zephyr net, used for embroidery.

Mechlin net, the mesh being the same as that made by hand, and cotton Brussels quillings, various.

Black silk Jacquard lace, made and finished entirely in the machine.

Silk Jacquard shawl, made entirely in the machine.

27 WHITLOCK & BILLIARD, *Mary Gate, Nottingham*—Manufacturers.

Specimens of machine-wrought cotton Mechlin laces, needle embroidered. The groundwork made from No. 520 yarn, spun and doubled.

28 HERBERT, THOMAS, & Co., *Nottingham*—Manufacturers.

Lace of various kinds from the warp machine.

Crochet lace from the warp and twist machine.

Blond edgings, from the twist machine.

29 MALLET & BARTON, *Nottingham*, and *New Basford*—
Manufacturers.

Specimens of silk lace, machine-wrought; silk lace, part machine and part needle-wrought; silk lace fringes, machine-wrought; cotton plat, or imitation Valenciennes; cotton laces, part machine and part hand-wrought; and fancy lace trimmings, machine-wrought.

30 HOLLINS, SAMUEL, *Nottingham*—Manufacturer.

Lace goods:—Machine-made cotton Brussels nets and laces, figured by the needle.
Various hosiery goods.

31 MOORE, SAMUEL WESTON, *Hockley Mill, Nottingham*—
Manufacturer.

Specimens of lace and net made from No. 520 lace thread, and of plain net, made from No. 630 thread.

[The application of machinery to the production of lace is very remarkable and interesting, as probably few introductions of machinery to textile manufactures produced so sudden an alteration on the expiration of the patent protecting it, in the ordinary course of fabrication. The bobbin-net machine was invented in 1809; it came into general use in 1823, and an immense stimulus was communicated to the manufacture. The powers of production of this machine are to hand labour nearly as 30,000 to 5, and the lace produced by it has, in plain articles, wholly superseded that made by hand.—R. E.]

32 RECKLESS & HICKLING, *Nottingham*—Manufacturers.

Embroidered white lace frouces, falls, scarfs, shawls, berthes, &c.

Black lace frouces of all widths, falls, scarfs, shawls, berthes, lappets, coiffures, &c., partly embroidered by machinery (on the Jacquard principle), and partly by hand.

33 VICKERS, WILLIAM, *Nottingham*—Manufacturer.

Specimens of black silk lace shawls, scarfs, mantles, falls, &c., the produce of the pusher bobbin-net machine; the outline introduced by subsequent embroidery.

34 GREASLEY & HOPCROFT, *Nottingham*—Manufacturers.

Lace articles. Jacquard pusher silk shawl. Figured needlework shawls, falls, &c.

41 STEEGMANN, HENRY, & Co., *Nottingham*—Inventors
and Manufacturers.

Figured lace-curtains, made entirely on the lace machine by Jacquard application.

45 FORREST & SONS, 101 *Grafton Street, Dublin*, and
Abbey Court Factory, Limerick—Manufacturers.

Laces: Royal Irish guipure; Irish appliqué; Limerick; black; and black appliqué.

Lace dresses, frouncings, squares, scarfs, mantles, polkas, veils, berthes, handkerchiefs, sleeves, baby's robes, robings, lappets, lace collars, &c.

47 VISCHI, ALEXANDER MARY JOSEPH, 21 *Greville Street, Hatton Garden*—Manufacturer.

Artificial flowers in wool. Basket in porcelain, containing a great variety of woollen flowers. Cane basket, containing a piece of green turf with flowers. Rustic basket of flowers.

Large piece of the "green turf." Application of the "green turf," or *parterve*, to a small carpet or rug. Metal flower-pots, filled with woollen flowers, with shades.

47A MOORE, Mrs., *Great Castle Street*.

An embroidered lace smoking-cap.

48 JANCOWSKI, W., *York*—Designer and Manufacturer.

State chair, of ruby coloured silk velvet, embroidered with gold, silver, and jewels, containing, on the back, the royal arms, supporters, scroll and motto, with wreath of flowers, in which the rose leaves are raised and detached from the surface; and on the seat the coronet, feathers, scroll, and motto of the Prince of Wales, surrounded by the rose, thistle, and shamrock, exhibiting ten different styles of embroidery: the frame of the chair is of carved wood, gilt.

Banner screen, containing the arms of the city of York, embroidered in gold, silver, and silk, upon pale and blue satin, and mounted on a carved gilt stand.

Picture, 18 inches by 12, copied from a German painting, embroidered in tent stitch with silk, on mosaic canvas.

49 DAVIES, Mrs. R. E., 29 *Harewood Square, Regent's Park*—Designer and Executor.

Set of chess-men, draught-men, dice, and board in needlework, the men being in characteristic costume; composed of silks, &c. The pawns are representations of Her Majesty's Body Guard of Gentlemen-at-Arms, in their full and undress uniform. Designed and executed by the exhibitor.

50 ROSE, ELIZABETH, *Pavler's Pury, near Towcester*—
Designer and Manufacturer.

Full-sized black lace dress. Shawl. Scarf shawl. Veil. Berthe, made of black pillow lace.

51 MEE, CORNELIA, *Bath*—Inventor, Designer, and
Manufacturer.

Banner screen. The banner composed of the flags of all nations, embroidered in fine silks, held by a figure of Peace, modelled from Canova's statue. The figure leans on a pedestal, and with the right hand points to the epoch of the Exhibition with an olive branch.

Couch, mounted in white and gold, embroidered in rare natural flowers.

Occasional chairs, embroidered on velvet, and mounted with white and gold.

Curtains, embroidered on white Cachemire and stripes of crimson Genoa velvet, in uncommon and beautiful flowers from nature.

Cushions, embroidered in shells, from nature.

These specimens are exhibited to show the application of needlework to the decoration of furniture. The needlework of most of the articles is done from flowers, minutely copied from Paxton's Magazine of Botany.

53 O'DONNELL, MARY, 69 *London Street, Reading*, and
18 *Sussex Place, Kensington*—Designer and Manufacturer.

Specimens of a new and improved method of appliqué lace-work, original design. Section of the same.

Blotting-book, ornamented with leather work on an ultramarine ground, intertwining the emblems of Great Britain, surmounted by the Prince of Wales's plume and motto.

Articles of ornament in gutta percha, leather, and fancy wood.

Hand-screens in gilt frames. New application of stamped gutta percha. Preserved real flowers and embroidery.

Cheval screen, a peacock embroidered in wool.

Cedar box, ornamented with carving.

Ultramarine box, ornamented with leather work.

Conversation hand-screens. Educational hand-screens. Counterpane, of new pattern.

55 TREADWIN, C. E., 27 *Cathedral Yard, Exeter*—
Manufacturer.

Devonshire, or Honiton, point-lace frounce, berthe, and lappet; designs procured from the Government School of Design, Somerset House, London.

56 ONION, ELIZABETH, 38 *Broad Street, Birmingham*—
Manufacturer.

Velvet drapery valance, worked with gold silk braid, on dark crimson velvet ground, ornamented with tassels, drops, and fringe.—New design.

Crimson valance fringe, in silk and worsted, ornamented with hangers. New drapery rope, rosettes and festoons, in crimson, gold, and white silk. New diamond valance fringe, in silk, ornamented with gimp head, hangers, rosettes, gimp ornaments, &c. Registered bell lever ornaments.

Curtain holder, with one tassel and two pendants, in crimson, white, and gold.

Ornaments for valances, in a variety of colours and designs. New patterns of coach and railway carriage lace.

Patterns of glass string, guard string, and other carriage trimmings.

57 BROWN, SHARPE, & Co., *Paisley*, and 18 *Watling Street, London*—Manufacturers.

Embroidered and tamboured book muslin dresses.

Embroidered scollop and insertion trimmings, flounces, collars, habit-shirts, chemisettes, sleeves, pincushion covers, handkerchiefs, and night-caps.

58 BROWN, S. R. & T., *Glasgow*—Manufacturers.

Specimens of muslins embroidered by the female peasantry of Scotland and the North and West of Ireland, consisting of ladies' and children's dresses, collars, caps, chemisettes, habit shirts, trimmings, &c.

59 PARK & THOMSON, *Glasgow*—Manufacturers.

Children's sewed robes; ladies' collars, sleeves, handkerchiefs, fancy habits, chemisettes.

Cambric and book flouncings; sewed trimmings.

60 MACARTHUR, D., & Co., *Glasgow*—Manufacturers.

Hamilton lace goods. White dress; black dresses; coloured dress; black cloak or mantilla; white cape; black cape; veils; pairs of sleeves.

61 CONNAUGHT SCHOOLS, *Glasgow*—Producers.

Specimens of sewed muslin.

62 ROBERTSON, JOHN, & SONS, *Glasgow*—
Manufacturers.

Sewed book-muslin and cambric squares for fancy covers for the drawing-room table.

Specimens of embroidery.

Samples of collars, habit-shirts, chemisettes, &c.

63 M'FARLANE & PORTEUS, 33 *Queen Street, Glasgow*—
Manufacturers.

Specimens of embroidered black and white muslin collars, chemisettes, habit-shirts, and sleeves for mourning.

Black silk lace veils, black and white lace cloaks, and black lace flounced embroidered robe skirt, exhibited for superiority of work.

64 BROWN, H., 100 & 104 *Virginia Place, Glasgow*—
Manufacturer.

Sewed book muslin collars; imitation cambric or jaconet collars; frilled chemisettes, on book muslin; fancy habits; three pair of sleeves or cuffs; four cambric handkerchiefs, embroidered on French lawn; embroidered book muslin dresses; patterns of book and cambric scollop, and insertion trimmings and flounces.

65 MACQUARIE, FISHER, & Co., *Glasgow*—
Manufacturers.

Black silk lace shawl, veil, and apron.

White cotton and linen lace dress.

White silk and gold under sleeves.

Coloured silk and gold apron and parasol cover.

66 MACDONALD, D. & J., & Co., *Glasgow*—
Manufacturers.

Embroidery on book muslin. Ladies' collars, chemisettes; habits, caps, &c. Child's caps and collars. Embroidery on jaconet and cambric; ladies' collars, chemisettes, sleeves, caps, &c.

Embroidered French cambric: ladies' handkerchiefs, child's caps. Embroidered baby linen: infants' robes, bodies, and caps; child's frocks, &c. Embroidered trimmings; jaconet and book edgings and insertions; cambric, book, and mull flounces.

67 SIMPSON, MILES, 5 *Aldermanbury Postern, 4 Milk Street, Manchester, Leek, and Derby*—
Manufacturer.

Specimens of the leading classes of raw silks, from France, Italy, China, Bengal, and Turkey, selected by Messrs. Durant & Co.

Sewing, netting silk, and twist, intended to show the varieties of quality, their richness and beauty of colour.

Sewing, netting silk and twist.

Raven and jet sewings, in weight and form as sold in the market, of four qualities.

Crochet and mohair silk, exhibited for quality and price.

Shoe mercery, consisting of silk and union galloons, doubles, braids, and round silk laces, yellow and black borders, &c. Specimens of union cord.

[In 1849 the enormous quantity of 6,269,179 lbs. of silk in its several conditions of raw, waste, and thrown, was imported into this country. The manufacture employs upwards of 33,000 individuals, and is carried on in nearly 300 silk factories. The sum annually expended on silk goods in England is taken at considerably upwards of fifteen millions annually.—R. E.]

68 FOOT & SONS, 33 *Spital Square*—Manufacturers.

Various fringes, elastic ribbon trimming, &c.

Rich dress or mantle fringe, with figured velvet, terry, and brocade lace heading, a combination of velvet and brocading, with the various branches of art used in trimming manufacture.

69 ARTHUR, ANN, 5 *Mortimer Street, Cavendish Square*—
Manufacturer.

Silk, worsted, and cotton braids for figuring. Silk, worsted, and cotton fancy netted buttons. Silk fringes for ladies' mantles; gimps for children's dresses; girdles and tassels. Silk and cotton olivets. Silk military braids and frogs.

70 GABRIEL, J. W., 135 *Regent Street*—Manufacturer.

Specimens of English embroidery, on silk and woollen goods for waistcoats.

71 DANBY, CHARLES & THOMAS, 14 *Coventry Street,*
and 43 *New Bond Street*—Manufacturers.

Crochet silk gimp robing, resembling the rose leaves and flowers, with buds, and made in the natural colour.

Various specimens of a Brandenburgh crochet silk gimp trimming, ladies' dresses; of girdles, in various colours and styles; and of silk fringes, for mantles, dresses, &c., of various new designs.

Specimen of a new style of head-dress, formed of crochet, silk gimp rings, and tassels of new design, and of various articles for ladies' dresses.

72 BRADBEE, G. W., 115 *Newgate Street*—
Manufacturer.

Needlework. Tapestry worked by Mrs. James Marsh, Lordship Road, Stoke Newington. Landseer's Horses at the Fountain. The Hawking Party. Anne Boleyn and Cardinal Wolsey. The Moral Lesson. The Monk. The Hawk.

A group of flowers, mounted as table or screen, the stem ornamented with flowers, &c., made of leather.

A bird mounted as above, the stem covered with tram silk by hand and wheel.

New fringes, for sacred edifices and rooms.

Patterns, gimps, tassels, dress trimmings, &c.

74 EVANS, R., & Co., 24 *Watling Street*—
Manufacturers.

Cornice, bullion, and silk ornament fringe. Bell-pulls. Curtain-holders. Silk cords, gimps, tassels, and rosettes.

Articles used for trimming ladies' and children's dresses and mantles.

75 BURGH, ROBERT, 42 *Bartholomew Close*—
Manufacturer.

Specimen of deep bullion fringe, wove to shape, trimmed, and ornamented for window, with cornice gimp attached. Valance for window.

Specimens of ornamental hangers, drops, pendants, fringes, ropes, gimps, cords, and tassels for drapery, &c. Rosette medallions. Ornamental watch hooks for beds, &c.

76 BARRETT & CORNEY, 70 *Little Britain*—Manufacturers.

Bars of silver-gilt and silver wire. Wire-drawing plates with holes. Hanks and bobbins of gold and silver fine wire. Gold plates, or flattened wire, used in headings of Lancashire cloths, Scotch muslins, &c. Gold and silver plates, used in spinning gold and silver threads.

Skeins of Italian, Bengal, and China raw and thrown silks. The same, dyed to colours used in gold and silver threads.

An assortment of gold and silver threads, used in the manufacture of laces, embroidery, and epaulettes; also in headings of cloths and muslins; of gold and silver bullions, used for military and naval sword knots, epaulettes, tassels, &c.; of gold and silver purls, plates, and spangles, used in embroidery; and of gold and silver chords, braids, and gimps, used for agulettes, epaulette crescents, &c.

Gold and silver laces.

Fine specimen of embroidery in gold threads, purls, plates, and spangles. Designed and worked by Rebecca Abraham, embroiderer to the Queen, 5 *Lisle Street*, *Leicester Square*.

77 IRISH WORK SOCIETY, 233 *Regent Street*—Producers.

Shawl, caps, and other specimens of Currah lace, imitation of Brussels. Specimen of black appliqué lace. Berthe, trimming, lappets, caps, and other specimens of guipure crochet. Trimming and collars of real guipure, made from old models.

Leghorn and Tuscan plait, made from Irish grasses, also a hat of the same, and specimens of straw plait.

Specimens of crochet from Donegal and other localities, applicable for dress or furniture.

Tabinets or poplins, from Mrs. Moran, Dublin.

Black and white pillow lace, made under the direction of Lady Louisa Tighe.

Maltese lace, made at the Carmelite convent, *Waterford*.

Fine knitting, from various localities.

Black silk mittens, knitted and netted.

Child's frock, braid imitation of guipure.

Child's frock, crochet guipure.

Flounce and trimming, imitation guipure.

Specimens of embroidery, worked *au blanc*, from *Middleton* convent, and Mrs. O'Donovan, of *Clonakilty*.

Specimens of embroidery from the county Kerry, Mrs. Naper, of *Lougherew*, and other localities.

Specimens of plain work from *Ballymena* and the county Kerry.

Specimens of woven cotton hosiery, manufactured by Messrs. Smyth, of *Balbriggan*, and 37 *Lower Abbey Street*, *Dublin*.

Mats of Irish wool, from *Carbury*, county *Kildare*.

Specimens of feather flowers, from the *Youghal* convent.

Hair chains and bracelets.

Specimens of trimmings in *broderie Anglaise*.

Flowers and feathers from the convent of *Youghal*, &c.

78 CLARK, J., 56 *High Street*, *Bradford*—Producer.

Table-cloth embroidered with thread on crimson sarsenet.

79 LEES, ROBERT, & Co., 36 *King Street*, *Cheapside*,
—Manufacturers.

Printed mohair tapestry. Plain, embossed, and shaded *Utrecht* mohair velvet. Plain and brocaded mohair velvets. Printed Chinese velvets of mohair. Livery and other mohair and worsted plushes.

80 SURR, JOSEPH, & SON, 12 *King Street*, *Cheapside*—
Manufacturers.

Silk twist of different colours, in balls and on reels, and in hanks and skeins. Manufactured at *Leek*, in *Staffordshire*.

81 HART, GEORGE, 7 *Market Street*, *May Fair*—
Inventor and Manufacturer.

Registered boxes, candlesticks, ornaments, hand-screens, and designs for table tops. The novelty consists in the application of muslin and cotton for this purpose. The materials of British manufacture.

82 SMITH, ANDERSON, & Co., 45 *Cheapside*, and 19 *South Hanover Street*, *Glasgow*—Producers.

Infant's cap, embroidered on French cambric; infant's robe, embroidered on fine nainsook; infant's bassinette cover, embroidered on fine nainsook.

83 LAMBERT, BROWN, & PATRICK, 236 *Regent Street*—
Manufacturers.

Army and navy epaulettes, and uniform laces. Court-dress waistcoats, richly embroidered. Masonic regalia. Church decorations, embroidered in gold. Cross, with crown of thorns, I.H.S., and glory. Fac-simile of the Bible used by King Charles I., when upon the scaffold on the day of his martyrdom; the cover embroidered in gold with all its enrichments, copied from Smith's "*Collectanea Antiqua*."

84 JACKSON, C., 10 *Curzon Street*, *Mayfair*—Producer.

An occasional table, mounted with *appliquée* embroidery.

85 HARRISON, T., 21 *Brownlow Street*, *Bedford Row*,
and 8 *Bolton Place*, *Brompton*—Designer and
Manufacturer.

Altar cloth and cushions, of rich crimson *Genoa* velvet, embroidered in gold, in the style of the 15th century.

86 STIRLING, MARY ANNE, 29 *John Street*, *Bedford Row*
—Designer and Manufacturer.

A fire-screen worked in chenille, &c., forming an ornamental group of flowers.

88 PURCELL, FRANCES, 3 *New Burlington Street*—
Producer.

A needle-worked table-cover.

90 STURMY, MARIA, 8 *Wellington Street*, *London Bridge*—
Designer.

Table-cover, a novel method of embroidery, worked with the needle, and without pattern of any sort.

- 94 BARNARD, EVERELDA, *Little Bardfield Rectory, near Dunmow*—Manufacturer.

Two figures in Berlin wool work, intended for the purpose of keeping doors open.

- 95 BARNES, R. Y., *City Road*—Manufacturer.

Specimens of decorative floor cloth.

- 96 BATTERS, MARTHA, *9 Rose-hill Terrace, Brighton*—Designer.

Picture in tapestry, representing (in medallion style) Louis XVIII. and George III.

- 97 BAYNES, RACHEL AGNES, *Cheshunt, Herts, near Waltham Cross*—Inventor.

Knitting designs:—In the centre, the Queen Prince Albert, the Royal Family, and the Duke of Wellington; around the circle "God save the Queen;" with other designs.

- 100 BENBOW, MRS., *11 Hamover Place, Regent's Park*—Producer.

Three specimens of tapestry embroidery, after the ancient Saxon style; designs scriptural.

- 103 BLACKBURN, ANN MARIA, *Beaumont Hill, Lincoln*—Manufacturer.

North-west view of Lincoln Cathedral, worked upon white silk, with the rovings of black lutestring, and manufacturer's silk.

The frame is made of old oak, taken from the Cathedral.

- 106 BOTTOM, JAMES, *65 Brook Street, Derby*—Designer and Manufacturer.

A hearth-rug, with the border and ends formed of upwards of 20,000 shreds of cloth, and the centre of lamb's wool.

- 108 BRIDGES, W., *Ensham, near Oxford*—Producer.

Tapestry wool-work, "The Last Supper," after Leonardo da Vinci, containing five hundred thousand stitches.

- 110 BRINTON, HENRY, & SONS, *Kidderminster*—Manufacturers.

Carpets of various kinds:—Patent velvet tapestry, scroll and flowers; white ground, flowers and leaves; cut pile, or super-Wilton, group of flowers and foliage in self-colours; dark ground, scroll and foliage; white ground, chintz, all registered designs. Patent Axminster velvet rugs.

- 111 ROGERS, —, *Wilton, Wilts*—Producer.

Specimen of embroidery—"Esther and Mordecai."

- 112 WILSON, CHARLOTTE, *Guildhall, Broad Sanctuary, Westminster*—Designer.

Netted quilt or coverlid for summer use.

- 113 BROOKS, E., *2 Chester Place, Kennington*—Manufacturer.

Specimen of embroidery, descriptive of English history, exhibiting, in the centre, the royal arms; at the top, Her Majesty's initials and crown; on the right, those of H. R. H. Prince Albert; and on the left, the badge and initials of H. R. H. the Prince of Wales. At the foot, the ancient harp of Ireland. The pomegranate refers to Catherine of Arragon. The trunk of a tree torn up by the roots was the badge of Edward III. and his son Edward the Black Prince, and alludes to his name, Edward of Woodstock. The port-cullis and fleur-de-lis were badges of the Tudors. The rose on the sun a favorite badge of the Plantagenets. The

open and empty pea-shell the badge of Richard II. The feathers crossed the badge of Henry VI. The dragon was the celebrated ensign of Cadwallader, last king of the ancient Britons, and now the badge of Wales. At the bottom the white horse of Saxony, the most ancient ensign of the House of Brunswick.

- 114 BROWN, M'LAREN, & Co., *Kilmarnock, Scotland*—Manufacturers.

Velvet-pile carpeting; imperial three-ply carpeting; Kidderminster superfine carpeting.

- 115 BRIGHT, J., & Co., *22 New Brown Street, Manchester, and 20 Skinner Street*—Manufacturers.

Patent velvet-pile and Brussels carpets and tapestries for curtains, portières, coverings for furniture, &c., woven at Rochdale, in Mr. R. W. Sievier's patent power loom, which raises the terry without the wire; the terry is cut, and the pile raised by a patent application whilst the loom is working; and the goods are printed at one operation in all the colours at Crag Works, near Macclesfield, by patent machinery, invented by Mr. Joseph Burch.

- 117 BURTON, M., *Libberton Bank, Edinburgh*—Proprietor.

A shawl, a table-cover, a rug, and two handkerchiefs; knitted on wires by an aged person. The pattern is original.

Picture frame, in imitation of old carved oak, composed of leather and putty. The design of the pattern taken from old carved work.

- 118 BURTON, MATILDA SARAH, *Aspringe, near Faversham, Kent*—Manufacturer.

"Italian girl," of Berlin wool; in fancy needlework.

- 119 CALEY, J. W. & F. G., *Windsor*—Designers.

Diaphane, transparent silk for blinds, with design: Star of the Order of the Garter, &c.; manufactured for the use of the Queen at Windsor Castle.

Diaphane, with design: the Rose, Thistle, and Shamrock.

- 122 CARDWELL, C. & T., *Northampton*—Manufacturers.

Pillow-lace—trimming for caps, collars, &c.

- 123 KIGHTLEY, J. T., *Northampton*—Manufacturer.

Pillow-lace for trimmings of caps, collars, &c.

- 125 CAULFIELD, W. B., *54 Coal Harbour, Blackwall*—Importer.

Specimen of knitted lace-work, intended for a baby's bassinet cover.

[The poor children at the school of Ballycastle Quay, north of Ireland, where this specimen was produced, have been for the last few years chiefly occupied in this species of hand manufacture.]

- 126 CHAMBERS, ELIZABETH REBECCA, *Wilton Square, Dublin*—Designer.

"A contribution carpet," worked for the benefit of the "Irish Society for Promoting the Scriptural Education of the Native Irish."

- 128 CHAPMAN, ELIZABETH ANNIE, *Great Bowden, Market Harborough*—Producer.

Tapestry copied from a painting by Leonardo da Vinci: Subject, "The Last Supper."

Exhibited for workmanship, which is intended to give the impression of a painting, even when closely viewed.

129 CLARKE, ELIZA, *Hackford, by Reepham, Norwich*—
Producer.

Collar, in point-stitch, with crochet edge, resembling Marguerite guipure lace; collar, crochet and needlework, imitating Brussels point-lace; collar, wholly of crochet, similar to ivory guipure lace.

130 CLARKE, ESTHER, 18A *Margaret Street, Cavendish Square*—Manufacturer and Designer.

Flounce of Honiton lace, five yards long, in the manufacture of which forty women were employed during eightmonths.

132 COLE, T., & SON, 18 *Newgate Street*—
Proprietors.

Specimens of Brussels, Venetian, and Kidderminster carpeting.

133 COLLINS & ROSE, *Kidderminster*—Manufacturers.

Specimens of carpets.

134 CONSTABLE, HANNAH, *Clonmel, Ireland*—Designer.

Infant's crochet dress, made of white thread.

135 COOK, WILLIAM, *Causeway, Chippenham*—
Designer and Manufacturer.

Cloth table-cover, 7 feet square, made with about thirty thousand pieces of broad cloth.

136 COPELAND, FANNY, 15, *Great Charlotte Street, Liverpool*—Inventor.

Sofa pillow, crocheted in imitation of tapestry.

138 JONES, L. V., 33 *King William Street, London Bridge*—Producer.

An embroidered map of the United Kingdom, showing the chief towns, railways, mountains, lakes, &c. Framed in English pollard oak. Size, 3 feet by 3 feet 6 inches. Executed by a girl fourteen years of age.

139 COVENEY, MRS., *Munster, near Queensborough*.

Carpet of thirty squares, worked in Berlin wool.

140 CRICK, ELLEN, *Soham, Cambridgeshire*—Designer and Maker.

A veil worked by the needle, exhibited to show that lace may be produced by the needle, equal to the Honiton lace, and in the hope that it may be the means of giving employment to many poor needlewomen.

141 CROSS, MARY, *Paul Street, Bristol*—Designer.

Crochet counterpane.

142 CROSSLEY, JOHN, & SONS, *Halifax*—Manufacturers.

Large pattern of mosaic tapestry for the walls of drawing-rooms, with portière.

Patent mosaic tapestry for the walls of dining-rooms; for carpet and table-covers; and for covers for sofas and chairs.

Patent mosaic rugs: subjects,—The British Lion, with appropriate motto; the Tiger; and landscape, and other designs.

Patent velvet carpet, with border and corners.

Twelve different designs in patent velvet carpets.

Pattern in patent tapestry carpet.

Patterns in Kidderminster and Dutch carpets; and of stair-carpets of different qualities.

144 CUNLIFFE, SARAH ANN, *Saffron Walden*—
Inventor.

Infant's knitted robe, consisting of 1,464,859 stitches, and 6,300 yards of cotton.

145 DANIEL & COSSINS, 55 *Herbert Street, New North Road*—Designers and Embroiderers.

Black satin embroidered waistcoat; the design represents Plenty, Strength, and Health, entwined with the national emblems, worked with silk in natural colours.

146 CONERDING, MRS. IDA VON—Designer.

Newly-invented knitting, the embroidery being seen only on one side.

147 HARDY, F. C., 9 *Mount Street Crescent, Dublin*—
Producer.

Specimens of knitting from Hackestown, County Calow, Ireland.

148 DAVIDSON, WILLIAM, Lieutenant Bombay Artillery, *Haddington*—Importer.

Embroidery from Hyderabad; adapted for table-cloths, shawls, cushions, &c.

149 DAWSON, DEBORAH, *Newtownbarry, Ireland*—
Proprietor.

Cuffs, hand-spun and knitted from the wool of French poodle dogs.

150 DEWAR, SON & SONS, *King's Arms Buildings, Wood Street*—Proprietors.

Table covers, of elaborate design, the first mixed fabric of the kind made in Spitalfields. Designed and executed by Webb & Son. The number of cards used in the production are 3,000, the number of cards used in the Jacquard machine 40,000. Chintz printed woollen table covers, and embossed.

152 DITL, BETTY, 23 *Charlotte St., Portland Pl.*—Artist.

Picture in embroidery—"Tasso's return"—in imitation of an engraving.

The back of an arm-chair, embroidery in silk and gold, designed on velvet, in the antique style.

Large fire-screen, embroidery in silk, chenille, and gold, in the modern style.

155 DOVE, CHRISTOPHER WESLEY, & Co., *Leeds*—
Manufacturers.

Velvet-pile Brussels, Kidderminster, and Three-ply carpets; with registered designs.

156 DOWBIGGIN & Co., 23 *Mount Street, Grosvenor Square*—Producers.

Carpet made at the patent Axminster carpet manufactory, Glasgow, for Her Majesty, designed by L. Gruner, Esq.

[The production of the peculiar description of carpets, known as "Axminster," form the principal manufacture of that town. It appears to have been commenced in imitation of the style of Turkey carpets, but a variety of patterns have been produced. The same kind of carpets are, however, produced in other places. The thick and soft pile of these carpets distinguishes them from others. In the present example, a peculiar modification of the ordinary process of manufacture has been introduced, by which the worsted is thrown to the surface, and does not appear on the other side at all.—R. E.]

157 DOWNING, G. & J. H., *King's Road, Chelsea*—
Manufacturers.

Specimens of floor-cloth.

158 SMITH, MARIA L., 24 *Basing Lane*—Designer.

A design for a lace curtain.

159 ELLIS, SOPHIE A., *Kildemock Rectory, Ardee, Louth, Ireland*—Designer.

Tatting or frivolité, for ladies' wear. Berthe, pair of lappets, habit shirt, baby's cap, pair of sleeves, and collars.

160 EUSTACE, RICHARD & JAMES, 10 *Weaver's Square, Dublin*—Manufacturers.

Turkey rug, exhibited as a specimen of Turkey carpet making, woven on woollen warp, the warprunning through from end to end, without cut or joining, and being looped at both ends. Tufted hearth rugs, girth, roller, and suspender web. Specimens of linen mill band.

161 EVANS, S. A., 18 *Charles Street, Middlesex Hospital*—Designer and Manufacturer.

The "Death of Douglas," after C. Landseer, in embroidery.

162 EVENDEN, ELIZA ANNE, 31 *High Street, Margate*—Manufacturer.

Berlin wool work; design, Mary Queen of Scots mourning over the dying Douglas, at the battle of Langside.

164 FLOWER, ANN, 25 *Duke Street, Grosvenor Square*—Designer and Manufacturer.

Hearth rug, representing the star and garter, surmounted by the British crown.

Picture, "Flags of all Nations," worked in cross-stitch in silk, chenille, beads, and wool.

165 FAUDEL & PHILLIPS, 38, 39, & 40 *Newgate Street*—Designers and Manufacturers.

State bed, in every style of needlework, from original designs and selections from the decorations by Raffaele, in the Vatican, and copies of the Aurora of Guido Reni, and Night by Thorwaldsen. The valances are of chenille, representing on a flat surface the folds of velvet, looped up by an imitation of gold cords and wreaths of poppies. The curtains are embroidered on blue satin and white watered Irish poplin. The counterpane is a combination of these designs; the canopy enriched by garlands of flowers, supported by angels. The bedstead is of carved wood, richly gilt, in the style of Louis Quatorze. The materials are principally of British manufacture.

This bed is represented in the accompanying Plate 119.

Patterns for needlework.—The Prince of Wales; from a painting by Winterhalter, in the possession of His Majesty the King of Prussia. The Choristers and Companion; from paintings by H. Barraud, Esq. Lady Jane Grey's reluctance to accept the crown; from a painting by Leslie, in the possession of his Grace the Duke of Bedford. The surrender of Mary Queen of Scots to the Confederate Lords at Carberry Hill; from a painting by Chisholm. Luther, Melancthon, Pomeranus and Cruciger translating the Bible. Groups of flowers for seats, prie-dieu and other chairs, cushions, &c.

Patterns for crochet. Specimens of worsted yarns. Purse-silk and twist; embroidery and floss silk; and grounding silk, manufactured and dyed in England.

168 FORTUNE, ELIZA, 101 *St. George's Road, Southwark*—Producer.

Hearth rug, knitted by hand. Subject: the emblems of the United Kingdom. Centre: a dog.

169 FRANKLIN, JOHN D., 14 *Lower Ormond Quay, Dublin*—Producer.

Printed floor-cloth, 16 yards by 6, woven in one piece, without a seam, carpet pattern; another, to resemble inlaid woods.

170 FREWEN, ELIZABETH, *Murlov, Bucks*—Designer and Manufacturer.

Lace collar, cuff, lappets, and neck-tie, made by hand on the pillow; in which an admixture of silk with the thread greatly improves the appearance of the lace.

174 GARDNER, M. A., 22 *Great Leonard Street, Finsbury*—Manufacturer.

Mosaic inkstand mat, knitted in varied shades of Berlin wool. Miniature bassinet, knitted in double Berlin wool, with bed and cover. Chair-back cushion, with weights. The exhibitor is blind.

175 GEORGE, C., 33 *Oxford Street*—Proprietor.
Velvet pile carpeting.

176 GILBERT, J., 7 *Charlotte Street, Old Kent Road*—Designer.

Design for Axminster centre carpet.

178 HEYN, EMMA, 14 *Gloucester Terrace, Gloucester Road, Old Kent Road*—Producer.

Ornamental vase of flowers, made of Berlin wool, with the crochet stitch.

180 GREEN, R., *Lichfield*.

Folding screen, worked by a nun of the Convent of Mercy, at Birr, Ireland.

181 GREENWOOD, ANNE CHRISTIANA, *Brookwood Park, Alresford*—Inventor.

Panels for decorating the walls of a room, painted with birds and flowers in the style of India paper.

182 GREGORY, THOMSONS, & Co., *Kilmarnock, Scotland*—Manufacturers.

Specimens of royal Wilton carpeting; of Brussels carpeting; and of Imperial carpeting. The first design by Mr. John Lauron, London; the other two by Mr. Thomas Barclay, Glasgow.

185 HALL, ANDREW, *Bank Buildings, Manchester*—Inventor.

Garden net, for shelter; and insect fender.

Glass substitute for hot-houses, green-houses, and small frames; preferable to glass, as a slow conductor of heat, and having a more equable temperature under its surface.

Canvases for embroidery, plain white, coarse, middle, and fine. Penelope, coarse, middle, and fine, with patterns of intermediate numbers, and of coloured canvas.

The above articles, with designs printed upon them, intended to be covered by the worker instead of copying a design from print paper.

186 HAMBURGER, ROGERS, & Co., 30 *King Street, Covent Garden*—Producers.

Specimens of embroidery and gold lace helmets, epaulettes, &c.

187 BLOOMFIELD, SUSANNA, *Poole, Dorset*—Manufacturer.

Needlework in Berlin wool:—Subject, "Raphael in the Vatican."

188 HANSON, CHARLES, *Fetter Lane*—Designer.

Design for an Axminster hearth rug, in the Italian style.

190 HARE, J., & Co., *Bristol*—Designers and Manufacturers.

Five floorcloth compositions, viz.:—One of chintzes; two of mosaic pavements; one of mosaic pavements; one of inlaid woods, and one of encaustic tiles. (*North Transept Gallery, Eastern Side*.)

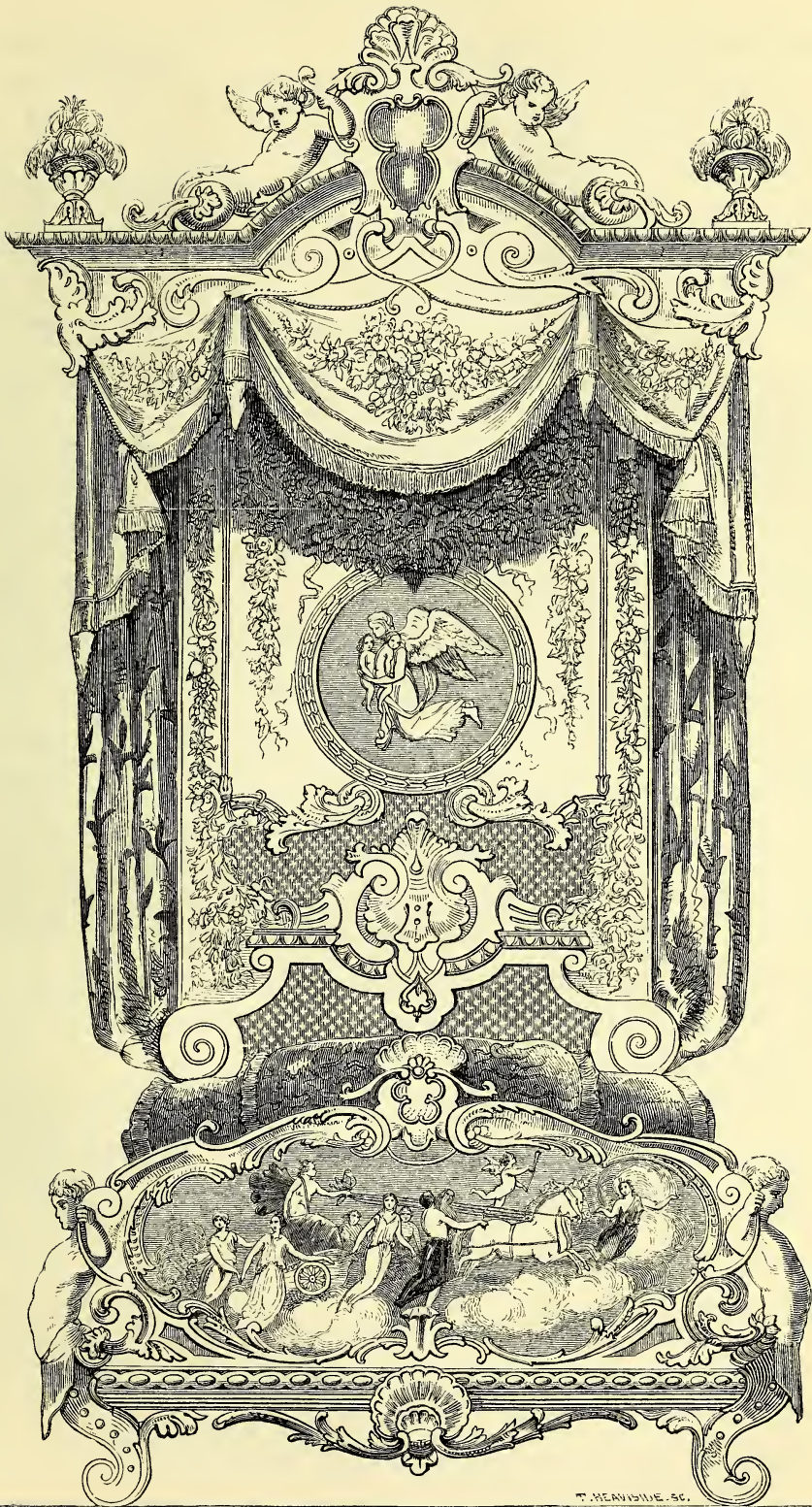

T. HENNING. SC.

119. STATE BED, ORNAMENTED WITH EMBROIDERY AND FANCY NEEDLEWORK: THE BEDSTEAD RICHLY CARVED.
FAUDEL AND PHILLIPS.

- 191 **HARMSWORTH, MARTHA**, *Twickenham*—
Embroiderer.
Tapestry. "The Last Supper," worked in French floss silk.
- 192 **HARRIS, GEORGE, & Co.**, *Stourport*, and 59 *Snow Hill, London*—Manufacturers.
Brussels velvet pile centre carpet, with border, for drawing-room, exhibited for design and quality.
Similar carpet, without border.
Brussels velvet pile centre carpet, with border, for dining-room or library.
- 193 **HARRIS BROTHERS**, 87 *Watling Street*—
Manufacturers.
Embroidered satin apron and babies' cloak, lawn pocket handkerchiefs; and cambric flouncings and insertions; all needlework.
- 194 **HARRISON, JOHN**, *Halifax, Yorkshire*—
Manufacturer.
White hearth-rug, all wool, used for bed-sides, doormats, carriages, &c.; superior for durability, and facility of being washed and dyed any colour.
- 195 **HARTREE, E. & G.**, 11 *Edjware Road*—
Designers and Manufacturers.
Registered *couvre-pied*, British emblems, designed and worked on a new silk canvas. Italian boy, worked and designed. Peter the Hermit. Deer-stalking. Joseph presenting his father to Pharaoh. Copies of a painting, worked.
- 196 **HARVEY & KNIGHT**, *Upper Marsh, Lambeth*—
Manufacturers.
Specimen of floor cloth, pattern copied from a Roman tessellated pavement discovered at Aldborough, Yorkshire.
- 197 **HARVEY, JOHN KEIR**, 25 *Ely Place, Holborn*—
Designer.
Designs for various kinds of printed fabrics; and for Brussels and other kinds of carpets.
- 198 **HAYTER, FRANCIS SHAFT**, *Hull*—Designer and
Manufacturer.
Carpet; needle-work in Berlin wool.
- 199 **HELBRONNER, RODOLPHE**, 261 *Regent Street*—
Designer and Manufacturer.
New style of needlework, similar to the Gobelins.
New designs, executed in silk and wool, on canvas.
New kind of canvas for embroidery.
Patent elastic draught, dust, and noise excluder, applicable with glue to doors, windows, wardrobes, pianofortes, and glass-cases. A light substitute for the heavy cord used in ladies' dresses.
- 200 **HENDERSON & Co.**, *Durham*—Manufacturers.
Wilton, or pile carpet, in Raphaelesque style of ornament, of the 16th century.
Brussels carpet, for drawing-room, cinque cento style.
Wilton, or pile stair carpet, regular five frames quality.
Yard-wide ingrain carpet. Yard-wide ingrain carpet, in bedroom style. Fine yard-wide damask Venetian carpet. Yard-wide twilled damask Venetian stair carpet. Twilled Venetian stair carpet. Fine Venetian stair carpet.
- 201 **HENDERSON & WIDNELL**, *Lasswade*—Manufacturers.
Portière, or door curtain, 10 ft. 6 in. by 5 ft.; in one piece; fine velvet. Whytock's patent. Probably the largest piece ever manufactured on this principle. Style—Louis XIV.
- Rich patent velvet carpets, with centres, borders, and corners; same style.
Patent velvet sofa carpets, and rugs.
- 202 **HATCH, CAROLINE**, *Tunbridge Wells*—Producer.
Specimens of embroidery.
- 203 **HILL, BENJAMIN**, *Olney, Buckinghamshire*—
Manufacturer.
Specimens of pillow-lace edging, suitable for collars, cuffs, sleeves, &c.; and insertion edging, suitable for caps, sleeves, stomachers, &c.
Pillow lace, suitable for infants' caps, ladies' caps, dresses, and flouncing.
- 204 **HILL & Co.**, *High Street, Worcester*, and *Great Malvern*—Inventors.
Needlework for ottomans, screens, hanging for walls, table-covers, chairs, &c., of the following designs:—
Panoramic view of the village of Great Malvern, Worcestershire.
Sketch of Windsor Castle, taken from Eton College grounds, from a miniature view by Baxter.
Sunset view of the ruins of Tintern Abbey, from a lithograph.
Two views of Witley Court, from pencil drawings.
Portrait in miniature, from a painting by Leonardo da Vinci.
Executed by the sisters E., P., S., and O. Rogers, of the above firm.
- 205 **HINDHAUGH, Mrs. MARY**, *Newcastle-upon-Tyne*—
Producer.
Copies from Landseer's picture of "Bolton Abbey;" Taylor's "Hawking Party;" Herring's "Feeding the Horses;" and Schopin's "Arrival of Rebecca." Worked as tapestry.
- 206 **HINDLEY, C., & Sons**, 134 *Oxford Street*—
Designers and Manufacturers.
Rich velvet carpeting. English hand-wrought carpets, Turkish style. Fine quality in original designs, elaborately flowered. Oriental carpets.
- 207 **HOLLOWAY, PHERE**, *Grove Buildings, Dorchester*—
Designer.
Quilt knitted by hand, in one piece, with cotton.
- 208 **HOLMES, J.**, *Kidderminster*—Manufacturer.
Carpets, commonly called velvet, suitable for dining or drawing rooms.
- 209 **HOPE, GEORGE CURLING**, 17 *Robertson Street, Hastings*—Designer.
Registered hassocks of common rush for the church or closet, with appropriate mottoes, in needlework.
- 210 **HUMPHRIES, THOMAS**, *Vicar Street, Kidderminster*—
Manufacturer.
Specimen of super-velvet pile carpeting. Registered patterns.
- 211 **HURST, G.**, *High Street, Bedford*—Designer and
Inventor.
Pillow-lace, with glass introduced into the figure.
- 212 **HALLING, PEARSE, & STONE**, *Regent Street*.
Velvet pile and Brussels carpets, registered.
- 213 **LADIES' INDUSTRIAL SOCIETY**, 76 *Grafton Street, Dublin*—Producers.
Limerick lace: shawls, handkerchiefs, and cazarees.
Spanish point, made in Ireland: caps, cuffs, and habit-shirts.

Old point, made in Ireland: fichus and frocks.
Real guipure, made in Ireland: head-dress and collar.
Crochet: caps, sleeves, collars, and frocks.
Embroidery: collars, caps, and handkerchiefs.
Cloth embroidery. Horse-hair ornaments.
Linsens: hand-spun and wove sheeting.
Knitting: stockings, socks, and mittens.
Thread lace. Hand-spun flannel.
Appliqué: scarfs, caps, berthes, lappets, flounces, shawls, veils, and dress.

213A SISTERS OF MERCY, *Kinsale, Ireland.*
Specimens of work: lace and embroidery.

214 ———
Knitting by a blind person: "Prayer for the Houses of Parliament."

215 JAMES, HENRY, 7 *Ferdinand Terrace, Pancras Vale*
—Inventor, Designer, and Producer.
Enamelled floor-cloth. Window-glass, ornamented by machinery, for halls, stair-cases, &c.

218 JOHNSTONE, J., 102 *Graham Street, Airdrie, Scotland*—Inventor.

Table-cover, consisting of 2,000 pieces of cloth, arranged into 23 historical and imagined characters, six equestrian scenes, a fox-hunt, and pantomime, with the regalia of Scotland in the centre. The design and execution is the sole work of the exhibitor, and it occupied his leisure hours for 18 years.

219 JONES, MARY, *Abbey Street, Chester*—Proprietor.

Bible cushion, copied, in fancy work, from a plan of the mosaic pavement in Canterbury cathedral, formerly composed of precious stones, gold, and jet.

220 COX, Miss A., 2 *Blossom Street, Norton Folgate.*
A rug worked from waste silk.

221 KEDDELL, JOHN STAPLES, *Sheerness*—Proprietor.
Armorial bearings, worked by the exhibitor in Berlin wool and silk.

222 BEACH & BARNICOTT, *Bridport, Dorset.*
Tapestry; a scriptural subject.

223 KETTLEWELL, MARY, *Clonmel, Ireland*—Proprietor.

Trimming lace, and lace berthes of different patterns. Large knitted lace collar, and fine lace lappet. Small thread lace scarf. Lace scarf, as fine as hair, done in Ardas.

224 KING, Miss, 3 *Bloomsbury Place, Bloomsbury Square*
—Designer and Manufacturer.

Mediaeval embroidery:—Design for a cover for the book of the Gospels, after the antique. St. John; design from a brass of Lawrence Seymour at Higham Ferrers. Royal arms, on a ground of cloth of gold.

225 KINGSBURY, LOUISA, *East Street, Taunton, Somerset*
—Designer, Inventor, and Manufacturer.

Basket of flowers, knitted in Berlin wool, from nature.

226 KITELEY, JOSEPH, *Kidderminster*—Manufacturer.

A Brussels velvet carpet in five-frame, green and gold; a Brussels velvet pile specimen in five-frame, white and oak; a Brussels carpet in five-frame, crimson and oak, suitable for drawing or dining rooms.

227 SCHOOL OF CHARITY, *Canjort Park, King's County, Ireland*—Producers.

Embroidered muslin, executed by the children of the school.

228 MOWLAND, CHARLOTTE G., 23 *Eaton Mews, South, Eaton Square*—Producer.

Wreath on white satin, with chenille and crape; design for an ornament or trimming. The exhibitor aged 11 years.

229 LAMBERT, ELIZABETH, *Tunbridge*—Designer.

Embroidery—Full-length portrait of The Queen, in gilt frame.

A group of flowers, with vase, in carved oak frame.

230 LANCHENICK, JANE A., 5 *Brompton Row, Brompton*
—Designer and Manufacturer.

Table cover; garter blue cloth. The design, an oak and acorn border; the corners, the rose, thistle, and shamrock, with the edge scalloped; the whole embroidered in gold-coloured silk.

231 MACKELLAR & HAMPSON, 50 *Old Change, Cheapside*
—Producers.

Royal lace mantle, figured by a patent process (silk texture).

232 LAPWORTH, ALFRED—Producer.

Axminster carpets. Patent carpets. Velvet pile and tapestry velvet carpets.

234 DIGGES LA TOUCHE, Miss, *Killmaule, Ireland*—Inventor.

Specimen of lace flounce, worked by the poor girls of Killmaule, invented at the time of the famine, to enable them to earn sufficient for their support.

235 VICCARS, RICHARD, *Padbury, Buckingham*—Manufacturer.

Lace for young infants' robes.

Lace for trimming an infant's cot, or a flounce for a lady's dress.

Lace crowns for infants' caps, corresponding with the broad lace.

Insertion for forming the body of the caps.

Laces for bordering the caps.

236 LESTER, THOMAS, *Bedford*—Manufacturer.

Specimen of Bedfordshire pillow-lace, being an improved arrangement of an infant's lace dress.

Improved lace fall-piece, to avoid joining at the corners; lace fall, complete; length of wide white lace for falls; length of white and black trimming lace; length of flouncing lace.

237 FRYER, Miss N., *Barnsley.*

Crochet counterpane.

238 WHEELER, Mrs. JOHN, 42 *Dorset Street, Portman Square*—Producer.

An occasional table, mounted with appliqué embroidery.

240 LOCKWOOD, GEORGIANA, 31 *Great Titchfield Street, Oxford Street*—Manufacturer.

A child's fancy crochet frock.

241 LEE, J.—Producer.

Specimen of lace made by a poor woman in Stone, Aylesbury.

- 242 MACDONALD, MARGARETTA, 105 *South Portland Street, Glasgow*—Manufacturer.
Fancy needlework, worked with Berlin wool and silk. Subject—"Haddon Hall in the Olden Time," by Frederick Taylor.
- 243 MCFARLANE BROTHERS, *Glasgow*—Manufacturers.
Chenille hearth-rug, 7 feet 3 inches long by 3 feet 4 inches broad, with landscape design, from Loch-Long, Dumbartonshire.
Chenille hearth-rug, 7 feet long by 3 broad; landscape design. Chenille hearth-rug, 7 feet long by 3 broad, with design, tiger jungle, hills in the distance.
Chenille hearth-rug, 7 feet long by 3 feet 1 inch broad, with design, water lily or lotus. Chenille hearth-rug, 8 feet 6 inches long by 3 feet 5 inches broad; design, scrolls and flowers. Pieces of chenille carpeting, each 2 feet long by 2 feet 3 inches wide, with same design.
- 244 MALLALIEU, WILLIAM, *Agent of the Moravian Establishments at Fulneck, near Leeds, and Ockbrook, near Derby*—Manufacturer.
Worked handkerchiefs of Moravian embroidered needlework, from Fulneck and Ockbrook.
- 245 ———
A crochet toilet-cover.
- 246 M'ARTEN, H., 97 *Great Charles Street, Birmingham*—Manufacturer.
Ancient design of funeral pall for hearse. Design from Mr. Pugin's "Glossary of Ecclesiastical Ornament and Costume."
- 247 M'DARMID, MARY ANN, *Bugthorpe House, near Nottingham*—Designer and Maker.
Embroidered quilt.
- 248 MACLEAN, JANE, *Tynan Rectory, Tynan, County Armagh, Ireland*—Proprietor.
Imitation guipure lace flounce, worked by the children of Tynan Glebe school.
- 249 RICHMOND LUNATIC ASYLUM—Producers.
Quilt knitted by the inmates.
- 250 MELTON, ELIZA, 8 *Peacock Terrace, Walworth Road*—Manufacturer and Proprietor.
Embroidery. Imitation in needlework of "The Last Supper" by Leonardo da Vinci.
- 251 MONKHOUSE, JOSHUA, & SON, *Barnard Castle, and 75 Wood Street, Cheapside, London*—Manufacturers.
Carpets, of Kidderminster fabric, cumber and point styles.
Dutch fabric carpets, all wool, and Dutch fabric carpets, warp made from silk noils.
- 252 MORTON & SONS, *Kidderminster*—Manufacturers.
Specimens of velvet pile carpets:—Crimson and colours (roses); ruby and chintz (flowers); crimson, green, &c. (lilies).
Saxony carpet:—crimson and oaks (scroll).
Brussels carpets:—white and gold (scroll); dark green and gold (ornament); royal blue and gold (ornament); ruby, crimson, and oaks (leaves); ruby, green, &c. (roses).
- 253 NAIRN, MICHAEL, *Kirkaldy, Scotland*—Designer and Manufacturer.
Floor-cloth, used for halls, lobbies, &c:—No. 1. Chintz pattern, eight colours, imitation of fine carpeting. No. 2. Granite pattern, four colours, imitation of granite inlaid.
- No. 3. Marble pattern, four colours, imitation of marble inlaid. No. 4. A combination of Nos. 2 and 3, representing marble and granite, inlaid alternately, showing that Nos. 2 and 3 can be made to work singly or together, thereby giving the advantage of three distinct patterns, with only two sets of blocks.
- [The canvas employed in the manufacture of floor-cloth, is produced principally in the north, and in large quantities at Dundee. The size of the canvas, 6 yards or upwards in width, and about 100 in length, will convey an idea of that of the loom producing it. The application of the oil colours and patterns is effected in various places. Prior to this, the canvas is prepared for the reception of the paint by a coating of size. The paint and pattern are applied by hand, and the latter is effected by the usual process of block-printing.]
- 255 LEY, F., *Victoria Cottage, Bickington, near Barnstaple, Devon*—Producer.
A piece of needlework in floss silk, representing the Bible encircled with roses, with an appropriate motto in gold letters.
- 256 BUTCHER, Misses, 2 *Clarendon Road, Notting Hill*—Producers.
Variety of Berlin wool-work.
- 257 NEWCOMB & JONES, *Kidderminster, and 19 Skinner Street, London*—Manufacturers. THOS. PAUL, & Co., *opposite the Mansion House, City*—Proprietors.
Model carpet of superior velvet pile, representing the Arms of the Company of Mercers, with emblazoned border, &c.
Velvet pile carpet in breadths; design, "the vine and passion flower."
Best Brussels carpet, in breadths; of a white ground and scroll chintz.
- 258 NEWTON, JONES, & WILLIS, *Temple Row, Birmingham*—Church Decorators.
Robes, hoods, curtains, and veils, embroidered in silk and gold.
Satin damask hangings, woollen hangings, velvet-pile carpets, &c.
- 259 OLVER, LYDIA, *Lisheard*—Manufacturer.
Embroidered collar, stomacher, and sleeves.
- 260 OSBORN, MATILDA, 4 *Sydney Square, Commercial Road East*—Producer.
"Mary, Queen of Scots, mourning over the dying Douglas," in Berlin wool.
- 261 PADWICK, ANNE, *Westbourne, Emsworth*—Designer and Manufacturer.
A crochet table-cover in Berlin wool.
- 262 PALMER, HELEN, *Dunse*—Producer.
Panel for a pole-screen, embroidered in coloured silks, upon white satin.
Lady's dress, embroidered in cherry-coloured silks, upon white silk.
Cushion for a chair, embroidered in coloured silks, upon white satin.
- 263 PARDOE, HOOMANS, & PARDOE, *Kidderminster*—Manufacturers.
Whytock's patent tapestry carpeting, in Brussels and velvet pile. The colours are permanently printed on the worsted before it is woven.
Skein of the worsted. Patent Berlin rugs.

- 264 PATENT CAMPHINE COMPANY, *Hull*—Producers.
A variety of rugs.
- 265 PATENT UTRECHT COMPANY, 36 *Steward Street, Spitalfields*—Producers.
Lace curtains, patent silk lace dress and curtains; patent lace quilt, scarf, and curtains; Spanish mantilla.
- 266 PEARSE, CLARA, *Broad Street, Bath*—Designer.
Crochet bed-quilt, illustrated with the Ten Commandments in the centre, with imitation of point lace border. The designer 14 years of age.
- 268 PERRY, EDWARD, The Rev., 26 *Portland Place, Leamington*—Producer.
Scarf composed of British silk, being the produce of 2,000 silk worms, which were kept in an out-house at Goodrich, in Herefordshire. The silk was wound from the cocoons and spun by Mrs Perry and her daughter; after which, it was made into the scarf now exhibited. The silk is in its natural or raw state, unmanufactured, and the colours of the silk produced by the male and female worms are preserved.
[In a preceding class will be found a brief notice of the labours of the late Mrs. Whitby to introduce the culture of the silkworm into this country. This notice accompanies a banner entirely wrought out of silk produced from worms bred in England. In the present, as in other instances exhibited, the same success has attended this art.—H. E.]
- 269 HEALD, BENJAMIN, *Old Swinton, Nottingham*—Designer.
A design for Honiton lace flouncings.
- 270 HALLOWELL, MRS. E., *Limerick*.
Knitted lace scarf.
Specimens of knitting by the poor Irish children near Limerick.
- 271 PHILLIPS, EMILY, 166 *Bermondsey Street, Southwark*—Producer.
“La Vendredi.”—eating meat on Friday.
- 272 PHILLIPS, REBECCA, *Swanbourne, Winslow*—Manufacturer.
Ornamental linen-thread pillow-lace.
- 273 PICKTHORN, ESTHER, *George Street, Hockley, near Birmingham*—Manufacturer.
Hearth-rug, raised, in needlework.
- 275 READ & HUMPHREYS, 21 *Clare Street, Bristol*—Manufacturers.
Folding screen on canvas, worked in cross and tent stitches. Two figures playing chess.
- 276 RISDON, JOHN, 194 *High St., Exeter*—Proprietor.
Fancy silk and velvet quilt.
- 278 ROBINSON, Miss, *Newport Terrace, Bolton, Lancashire*—Designer.
Group of flowers worked in a new style, from an oil painting, by the exhibitor.
- 280 RODGERS, JOHN, & SON, *Islington, near Birmingham*—Manufacturers.
Purses, embroidered in the weaving: such embroidery having been previously done only by hand.
- 281 ROLLS, JAMES & GEORGE, & SON, *Lower Kennington Lane*—Manufacturers.
Piece of floor-cloth.
- 282 ROLPH, JONAS, *Coggeshall, Essex*—Manufacturer.
A dress with two flounces, a fall, a berthe, and a lappet, in imitation of Brussels point lace, in tambour-work; exhibited for workmanship.
- 283 ROOME, ANN EMPRINGHAM, *Beaumont Hill, Lincoln*—Designer and Manufacturer.
South-west view of York Cathedral, worked upon white silk, with the rovings of black lutestring and manufacturers' silk.
- 284 ROYAL VICTORIA ASYLUM for the BLIND, *Newcastle-upon-Tyne*—Designers and Manufacturers.
Shawl, knitted of wool. Queen's veil, knitted in imitation of lace. Jenny Lind veil; and baskets. Manufactured by the blind inmates of the asylum.
- 285 RUSSELL, SARAH ANN, *Bromsgrove, near Worcester*—Manufacturer.
Berlin wool work. Subject—Joseph presenting his father to Pharaoh.
- 286
Crochet wool toys: a tea service, &c.
- 288 SEWELL, EVANS, & Co., 44, 45, & 46 *Old Compton Street*—Proprietors.
Straw-work on crape, applicable to various other fabrics. A patent Axminster carpet. Rich figured damask silk, brocaded in various colours. Plain moire antique. Figured damask, made in a Jacquard loom. Specimens of knitting, &c., by poor Irish children.
- 289 SHAKELL, MARIA, FANNY & EDWARD, *Belle Vue Cottage, Shirley, near Southampton*—Producers.
Needlework: Scripture subject, mounted in a frame designed and executed by E. Shakell.
- 291 MORANT, J., 91 *New Bond Street*.
Various carpets.
- 293 SHEDDEN, HUGH, 38 *Stanhope Street, Liverpool*—Manufacturer.
Royal standard of England, made of bunting, the article used for flags in the marine service; the devices embroidered on the whole cloth, of Berlin wool.
- 294 SHERIDAN, PETER, 22 and 23 *Parliament Street, Dublin*—Manufacturer.
Brussels and Kidderminster carpeting, manufactured a 23 Pimlico, Dublin. Hearth rugs.
- 295 HEALD, HENRY, *Old Swinton, near Nottingham*—Designer.
A design for a black lace shawl.
- 296 SHIRER, ALEXANDER, *Cheltenham*—Designer.
Cut-pile Brussels carpet, foliage British oak with acorn, horse-chestnut leaves and blossom, with fern and palm leaves. Manufactured by H. Brinton and Sons, Kidderminster.
- 298 SHULDAM, HARRIET, *Dunmanway, Ireland*—Producer.
Lace work.
- 299 SIBTHORPE, FANNY LOUISA, *Limerick, Ireland*—Producer.
Piece of Berlin work, subject “Haddon Hall in the days of yore;” and the “Morning of the Chase,” in a carved oak frame.

301 SIM, C. J., *High Street, Bedford*—Manufacturer.
Bedfordshire pillow-lace.

302 SIMCOX, G. P., *Kidderminster*—Inventor and
Manufacturer.

Two large finger worsted rugs, containing the arms of the borough of Kidderminster.

Small sample of velvet carpet, made on the occasion of the marriage of H.R.H. the late Princess Charlotte with Prince Leopold of Saxe-Cobourg.

Registered pattern of double-breadth second Brussels. Registered patterns of Brussels velvet, woven on new principle.

Several coloured designs of carpets called the patent beaver, woven by steam-power.

304 SMITH, MRS. RICHARD, *Rolvenden, Staplehurst, Kent*—Manufacturer.

Group in wool; the Queen, the Princess Royal, and the Prince of Wales.

306 FOSTER, RUTTY, & Co.

Embroidered lace curtains.

307 STOKES, STEPHEN, *Kevin Street Police Barrack, Dublin*—Inventor.

Table cover of mosaic cloth-work, representing the royal arms; the royal family at a review; the capture of the French eagle by the royal dragoons at Waterloo; a sketch from Ballingarry; war chariot, &c.; all composed of pieces of cloth fine-drawn together.

308 SUTTON, ELIZA, *Mailstone*—Designer and
Manufacturer.

A fine white crochet bed-quilt, the centre composed of a group of flowers, above which are three scriptural sentences, in English, French, and German; below the centre are three other scriptural sentences, in Italian, Spanish, and Latin; at each side is a scriptural sentence in English; in the borders are dates and allusions to the Great Exhibition, in English: the whole finished with a wide lace, and lined with pink cambric.

309 SUTHERLAND, JANET, *Falkirk, Scotland*—Inventor,
Designer, and Manufacturer.

Drawing-room table-cover, embroidered with coloured satin on a black satin square or ground; in a new style; the flowers, figures, &c., are formed and arranged without the aid of drawings or patterns.

310 TARIN, M. L. A., *8 Nelson Street, Mornington*

Crescent, Camden Town—Designer and Inventor.

Berlin wool needlework.

Lamp pillar, &c.

312 TAYLER, ANN MARIA, *Middle Chinnock*—
Proprietor.

Historical piece of needlework in wool—Mary Queen of Scots weeping over the dying Douglas.

313 TENNISON, MRS. M. A., *8 Broughton Place, Hackney Road*—Producer.

Chair of papier maché, of the Elizabethan style, inlaid with mother-of-pearl of all colours, with cushion of needlework.

315 TEMPLETON, J., & Co., *Glasgow*—Manufacturers
and Patentees.

Patent Axminster carpets, intended for drawing-room; for dining-room or library; in Persian style, for dining-room or drawing-room; and in Turkey style, for dining-room, &c.

Carpets bordered and chintz fitted for parlour or drawing-room; hearth-rugs, patent Axminster; breadth carpeting; stair or landing carpeting; Tournay table covers; piano covers; and door or window curtains.

[These carpets, rugs, &c., are woven in the loom, and not tufted or knotted to the warp as in the older method of making such goods. The worsted being thrown entirely to the surface of the fabric, instead of appearing on both sides, economises the material, and gives a smoother surface.]

316 JOHNSON, GEO., & Co., *11 Bow Churchyard, and 4 Bow Lane*—Manufacturers.

Mourning collars, &c.

317 THWAITES, MARY, *4 Quadrant Road, Lower Islington*—Proprietor.

Fine knitted thread shawl. Valenciennes lace bonnet. Knitted bonnet and parasol. Embroidered cambric handkerchiefs. Cambric pincushion, with arms of England embroidered. Crochet d'Oyley. Specimens of imitation Valenciennes lace. Manufactured by the poor children of Newry.

318 TURBEVILLE, SMITH, BOYLE, & Co., *9 Great Marlborough Street*—Producers.

Axminster carpet. Velvet pile tapestry carpet, designed from native flowers. Brussels carpet, of Elizabethan design, crimson and oak.

320 TROLLOPE, ROSE, *6 Allen Terrace, Kensington*—
Producer.

Folding screen of tapestry work.

321 CARDINAL & Co., *St. Helen's Place, Bishopsgate.*

Persian and Turkey carpeting.

322 TURNER, AGNES, *Sutton Rectory, Dartford*—
Manufacturer.

Knitted lace scarf, three yards long, and three quarters wide.

323 UPHILL, MARY ANN, *Fonthill Bishop, Salisbury*—
Designer and Manufacturer.

A cushion for the toilet, composed of thread and fine gold twist of different texture. In the centre of this work is introduced the profile of Her Majesty, Prince Albert, and all the Royal Family, with their initials. The band round the work has this motto worked in letters of lace,—“Long live Victoria Queen of England, Prince Albert, and all the Royal Family.” The whole work is ornamented with the Crown of England, the Rose and Thistle, Bible and Sceptre, and other emblems of Royalty. Twist, of different texture, in cushion lace.

A lace scarf, and a bassinette lace cradle-cover of similar manufacture.

324 VEEVERS, LETITIA, *Mohill, County Leitrim, Ireland*—
Producer and Inventor.

Articles manufactured from the fibres of plants and flowers, viz. :—From the common nettle, pocket handkerchiefs trimmed with lace of the same material, shawls, scarf, bonnet, parasol, lace collar, and veil; from the hemp nettle, parasol and veil; from the Lavatera, parasol and veil; from the honey plant, parasol; from the sweet pea, bonnet and lace collar; from the honeysuckle, bonnet and lace collar; from the nasturtium, parasol; from the Keria japonica, bonnet; from the marsh mallow, bonnet; from silk, mittens; from the bee plant, a cap. Shawl of nettles.

Specimens of the flax and threads from which the preceding articles are manufactured.

325 LAWSON, JOHN, *4 Sidmouth Street, Gray's Inn Road*—
Designer.

Axminster hearth-rug, manufactured by Blackmore Brothers, Wilton. Various designs for carpets. Specimens painted on ruled paper for the weaver.

327 THE VICTORIA FELT CARPET COMPANY, 8 *Love Lane, Wood Street*—Manufacturers.

Specimens of patent felt carpeting. Printed and embossed table-covers, felt. Embossed window curtains, felt. Fine cloth, felt.

Manufactured at Leeds, and printed in London.

328 VINCENT, SAMUEL, *Turvey, near Olney, Bucks*—Manufacturer.

Bedford and Buckinghamshire pillow-lace, veils, lace collars, and lace. Name and address in letters, formed of lace. Lace, pillow and bobbins, by which the lace is worked.

329 VOKES, FREDERIC S. T., 9 *Hope Cottages, Cottage Grove, Bedford New Road, Clapham Rise*—Designer and Manufacturer.

Superfine scarlet cloth table-cover, braided with upwards of 2,000 yards of black mohair cord, executed without patterns or pouncing, on a new principle.

330 HAYES, ELEANOR JANE, 24 *Richmond Terrace, East Street, Walworth*—Designer and Manufacturer.

Pictures composed of needlework and steel beads:—The successful deer-stalkers of the Highlands. Three chorister boys. The royal arms of England. Two country girls (seated in a shrubbery). The Last Supper. The novelty of these articles consist in their being of needlework, and forming a surface of glass, representing figures, animals, and foliage.

334 WARD, ANNE, *Coleraine, Ireland*—Designer and Executor.

Specimens of needlework. View of "The Giant's Causeway;" an "Italian scene," by Vernet; and an "Arctic scene." The groundwork is linen in the first view, and lutestring in the others. The work is an imitation of line engraving, and the material employed, cotton and silk thread.

335 WASHBOURN, ANN, *Great Marlow, Bucks*—Manufacturer.

A muslin small dress over a blue slip, embroidered. A boy's embroidered muslin dress. A child's frock.

336 WATERHOUSE, EMMA ISABELLA & MARIA ADELAIDE, *Claremont Cottage, Loughborough Road, Brixton*—Makers.

Crochet counterpane, 12 feet square, worked in Strutt's cotton, representing a variety of flowers; the centre of the counterpane a cluster of roses encircled with a wreath of flowers and leaves; the insertion composed of a wreath of lilies, entwined round a pole; at the four corners are a trumpet flower, a rose, a convolvulus, and a wild rose; finished off with a deep edging. The patterns were all designed by Wilks, Regent Street.

337 WATSON, BELL & Co., 35 & 36 *Old Bond Street*—Manufacturers and Importers.

Extra superfine Axminster carpet, designed by Lewis Gruner, Esq., exhibited by Her Majesty the Queen. The design of this carpet is represented in the accompanying lithograph drawing.

Carpet in the renaissance style, designed by John Lawson.

Carpet in the Louis Quatorze style, designed by M. Brandeley.

A superfine Axminster carpet in the Italian style and colouring, designed by James Crabb.

A fine Axminster carpet, in the Persian style and colouring, adapted for dining-rooms. All manufactured by Blackmore Brothers.

Superfine velvet bordered carpet, crimson and chintz designed by John Lawson.

Brussels carpet, bordered, in the Persian style, applica-

ble to rooms of any size, at the ordinary cost of Brussels carpet.—Designed by John Arbuthnot, and manufactured by Watson & Co., Kidderminster.

Carpets manufactured in the province of Masulipatam, and imported from Madras.

Real Turkey carpets, manufactured at Ushak, in the province of Aidin, and imported from Smyrna.

339 WAUGH & SON, 3 & 4 *Goodge Street*—Designers.

Royal velvet pile carpet, purple ground. An allegorical design for a carpet for a Royal palace.

341 WELLS, B. W., *Windmill Lane, Camberwell*—Manufacturer.

Registered floor-cloth, the pattern being an imitation of Berlin wool work, printed in gold and lake colours.

343 WHITE, SON, & Co., 78 *Watling Street*, and 108 *Cheapside*—Proprietors.

Kidderminster, cut pile Brussels, velvet pile tapestry, and square velvet pile carpets. Printed cloth table-covers. Silk worsted damasks.

345 WHITWELL, JOHN, & Co., *Kendal*—Designers and Manufacturers.

Kidderminster carpeting. Twilled Venetian carpet, woven in a power-loom, and with variety of colour and texture. Improved Brussels carpet, with new arrangement for pile and texture. Berlin hearth-rug, new design and material.

347 WHITNEY, E., *Cleveland Place, Bath*—Designer.

Embroidered lady's apron. Coat of arms in needlework.

349 WILLIAMS, Lady GRIFFIES, *Marlborough*—Producer.

"The Last Supper," from the painting by Leonardo da Vinci, worked in German wool and floss silk.

350 WILSON, ANNE, *Downpatrick, Ireland*—Manufacturer.

Fancy work in wool—subject, "Shipwrecked sailor;" in which new stitches, invented by the exhibitor, are introduced to give effect to different parts of the picture.

352 WOOD, HENRY & THOMAS, 22 *Watling Street*—Proprietors.

Printed and embossed cloth table-covers. Printed all over cloth.

Brussels carpet.

354 WOODWARD, B. HIGGINS, *Kidderminster*—Manufacturer.

Large velvet pile carpet, in the ornamental style. This species of carpeting is capable of being made to any required length or width, and in varied colourings, to correspond with other furniture; and can be produced at the ordinary price.

Specimens of the same pattern in Brussels quality, and varied colourings, showing its adaptation to the style of any room, with border for the same.

Specimens of various colourings of the "oak branch," in Brussels quality.

Specimen sketched from the Acacia, in Brussels quality.

Specimen of wool netting, for tray covers.

355 WOODWARD, HENRY, & Co., *Church Street, Kidderminster*—Manufacturers.

Carpets:—Velvet pile, ruby ground, with stems and chintz flowers, and border surrounding it, for drawing-room floors.

Brussels pile, arabesque pattern, for dining-room floors.

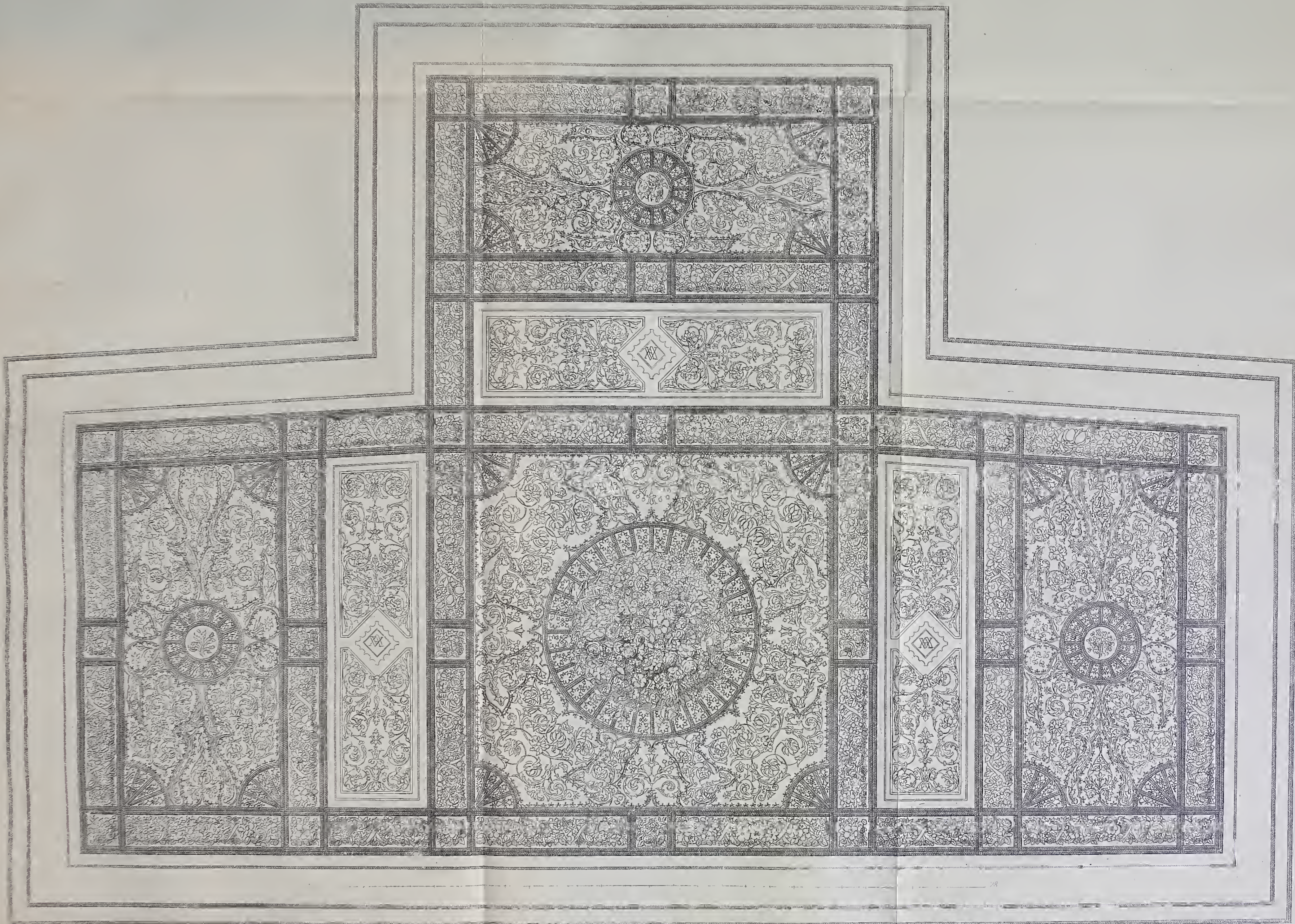

Manufactured by Blackmore Brothers.

An Arminster Carpet for Her Majesty's Drawing Room Windsor Castle, produced under the special directions of Watson, Bell & Company, 35 & 36 Old Bond Street, London.

Brussels pile, scroll on a rich crimson ground, for dining-room floors.

Velvet pile, ivy leaves and stems, lying on moss and wild weeds, for stairs and corridors.

All registered designs.

356 WOOLCOCK, CATHERINE, 13 *New Quebec Street, Portman Square*—Manufacturer.

Banner screen. Design, the arms of England, surrounded with drapery, and intersected with branches of olive; with pendant wreaths of the rose, shamrock, and thistle, crocheted with silk in numerous colours.

357 WRATISLAW, MATILDA EMILY, *Rugby, Warwickshire*—Designer and Manufacturer.

Cap, worked in crochet in imitation of point lace; design, rose, trefoil, and thistle.

358 WRIGHT, CRUMP, & CRANE, *Kidderminster*—Manufacturers.

Velvet pile, dining-room, drawing-room, and boudoir carpets, bordered complete.

Brussels carpets, for dining and drawing rooms.

Stair carpets.

365 ROBERTS, Mrs., *Bezley*—Producer.

A knitted counterpane.

367 CHAPLIN, CHARLES, 2 *Providence Place, Prospect Row, Woolwich*—Inventor.

Table-cover, or bed-quilt, containing 3,230 pieces, and 127 skeins of silk. Made by the exhibitor.

371 SMITH & BABER, *Knightsbridge*—Inventors, Designers, and Manufacturers.

Floor cloth, in imitation of ancient tessellated pavements; comprising a centre and borders, being copies of Roman pavements discovered in England.

Floor cloths, copy of Roman tessellated pavement discovered in England, and in style of Roman tessellated pavement.

372 BERNARD, Hon. JANE GRACE, *Cork, Killrogan, Bandon, Ireland*—Producer.

Knitted quilt for a baby's crib. Knitted bag. Exhibited on behalf of the workers, the children of Killrogan parochial school, Bandon.

373 PRIOR, Rev. H. E., *Lucan, Dublin*—Producer.

Specimens of Irish lace, the work of the Lucan Industrial School.

374 WEST, C. MARY, 1 *Brougham Terrace, Kingstown, Dublin*—Designer, Inventor, and Manufacturer.

Scarf of black lace, embroidered in a new style, in Deccan silk of different colours, interspersed with wings of the Indian beetle.

Flounces for ladies' dress, of same materials and work.

375 BATES, JEMIMA, *Great Dover Street, Surrey*—Designer.

Specimens of needlework upon machine net; handkerchief; infant's cap.

377 DALRYMPLE, MARY ELIZABETH, 37 *Cosehill Street, Eaton Square*—Inventor and Producer.

Table-cover of fawn-coloured cloth, embroidered with chenille; flowery pattern. An embroidered quilt.

378 FANCOURT, CATHERINE, *Grimsthorpe, near Bourne*—Designer and Manufacturer.

Fancy bed-quilt.

379 LADY MAYORESS (1850), and 150 LADIES of GREAT BRITAIN the executants. The design by John W. Papworth, Esq., Great Marlborough Street; the patterns painted by, and the work executed under the superintendence of, W. B. Simpson, West Strand.

A Berlin wool carpet, 30 feet long and 20 feet wide, worked in detached squares, which have been subsequently joined together to form the complete design. An illustration of a branch of manufacture which may afford to its executants a recompense more liberal than they can obtain in most other sorts of needlework.

This manufacture may also apply to the entire decoration of a room, as tapestry, furniture, &c. The initials of the executants form the ornament of the outside border. The whole design is connected by wreaths or bands of leaves and foliage, the centre group representing the store from whence they have been distributed.

Part of the patterns of the Berlin wool carpet exhibited by Her Majesty. The whole design is painted in one piece as a picture; on being subdivided the squares have the thread lines printed upon them. By this arrangement the setting out the pattern or second painting on squared paper from a picture first made is rendered unnecessary.

381 GEORGE, J. B., 4 *Wells Street, Gray's Inn Road*—Designer.

Design for an Axminster centre carpet, in the Italian style.

382 BRAYSHAW, JOHN, 118 *Church Street, Lancaster*—Producer.

Counterpane of mosaic needlework, 12 feet long by 10 feet wide, divided into 44 compartments, each representing a popular print, worked up of coloured pieces of cloth, without colouring matter; with scroll on the border, of new design.

384 KIDDLE, JOSHUA, *Norwich*—Inventor.

Woven cushion, completed in the loom without the aid of needlework; figured on both sides.

386 GILL, WILLIAM LEWIS, *Colyton, Axminster*—Manufacturer.

Honiton lace:—Portion of an original design, intended for the founce made for Her Majesty.

Portion of a new design for a scarf.

Collars in various designs.

Colyton chromatic silk berthe, made on the pillow.

Silk lappet, designed from the Alhambra, made on the pillow.

Lace scarf, berthe and sleeves.

Patterns of lace.

388 AYERS, WILLIAM, *Newport Pagnell, Bucks*—Producer.

Specimens of Buckinghamshire pillow-lace pieces.

390 JACKSON & GRAHAM, 37 & 38 *Oxford Street*—Producers.

London carpet; the border formed by palm leaves and flowers; shields with fruit in each corner; group of flowers in the centre; and filled up with crimson scrolls on marone ground.

Carpet, of Moresque design.

Carpet, with flower upon dark marone ground, border in panels, and medallions, with arabesque scrolls and flowers.

Specimens of velvet pile carpets. Patent tapestry velvet carpet and border; design, orchidaceous plants upon dark green ground. Carpet,—roses upon dark marone ground.

London rugs.

Carpet loom at work. (*North Transept*).

391 TAWTON, MARY, 9 *Union Street, Plymouth*—
Manufacturer and Designer.

Child's cloak, braided, embroidered, and interspersed with open work.

Its novelty consists in the introduction of open work into French merino; exhibited for the style of braiding, the embroidery, and the difficulty of execution. The open work, although having the appearance of insertion, is worked in the same material.

392 PENLEY, E. A., *Grove House, St. Peter's, Margate*
—Designer and Manufacturer.

Silk patch-work table cover, box pattern, containing upwards of 2,000 pieces, and 500,000 stitches.

394 BENNOCH, TWENTYMAN, & RIGG, 77 *Wood Street*—
Manufacturers.

Black and coloured ribbons. Shoe ribbons and ferrets. Silk handkerchiefs.

For dresses, mantles, &c.:—Cameo, lace, and self-quilling trimmings. Fancy braids.

Silk fringes, plain, glacé, Naples, and fancy headings. Bullion fringes, plain and fancy headings. Silk gimps and cords. Girdles.

Gimp, strand, and Naples cord on bobbins, for manufacturing purposes. Silk and cotton wire for bonnets. Silk laces for boots.

Sewing-silk, for the use of tailors and milliners.

Silk twist, in balls and on spools, for the use of tailors.

Netting-silk, for purses, hair nets, &c.

395 BEAVIS, J., 27 *Mint Street, Borough*—Manufacturers.
A hearth rug.396 HEAL & SON, *Tottenham Court Road*—
Manufacturers.

A crimson satin eider-down quilt, with white satin border, embroidered in colours. (This quilt is represented in the accompanying Plate 141.)

Duvét in blue and gold silk, filled with eider-down, to lay across the foot of a bed.

398 SZAFFELD, LEAH, 4 *Dean Street, Finsbury Square*—
Producer.

Portrait of Her Majesty and His Royal Highness Prince Albert, in Berlin wool work.

Cartoon: subject, "The finding of Moses in the bull-rushes," in Berlin wool work.

400 BENTINCK, Colonel HENRY, for ROBERT PALMER
—Producer.

A table-cloth, showing, in embroidery, the Royal Arms, and different devices, made by Robert Palmer, a private soldier of the 1st battalion Coldstream Guards.

403 UNDERWOOD, W., 1 *Vere Street, Oxford Street*—
Manufacturer.

Heraldic tapestry hanging, being a new application of heraldry to tapestry, hangings, portières, &c. The Royal Arms in the centre can be replaced by those of any other family.

Tapestry hangings of silk and worsted combined. The design composed from the artichoke and its foliage, adapted for hangings and portières. (*North Central Gallery.*)



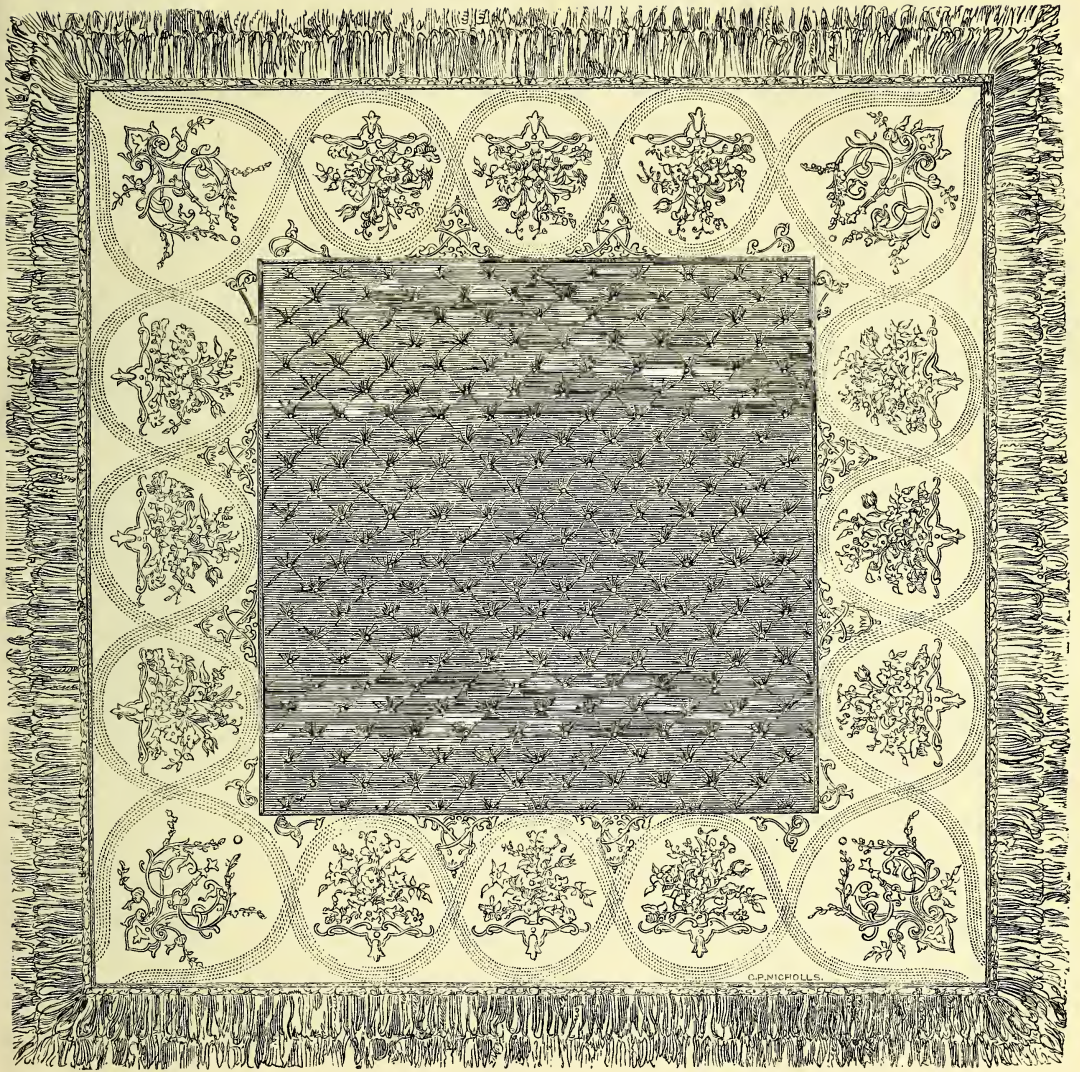

141. CRIMSON EIDER DOWN SATIN QUILT, WITH WHITE BORDER, EMBROIDERED IN COLOURS. HEAL AND SON.

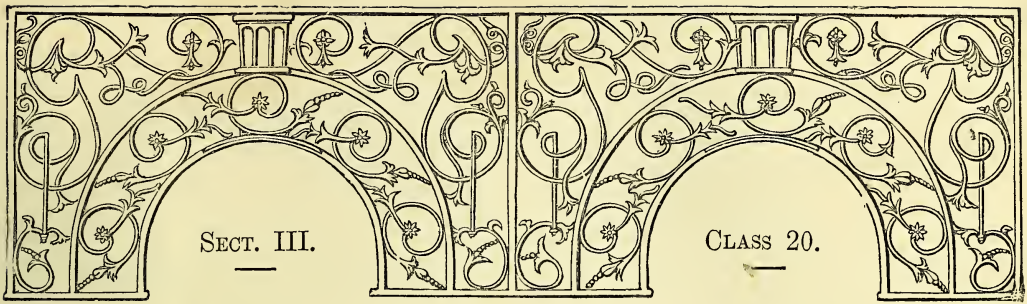

ARTICLES OF CLOTHING, FOR IMMEDIATE, PERSONAL,
OR DOMESTIC USE.

INTRODUCTION.

THOUGH important, considered in its social relations, this Class requires but a short prefatory notice, including as it does articles, which the requirements of daily life have rendered familiar to every person; still, in another respect, it has its interest. Preceding Classes have referred to the production of what may be regarded as the raw material of clothing, the present Class appears as the representative of the more advanced states of manufacture to which cotton, flax, silk, and woollen goods are carried, in their adaptation to personal or domestic use. The unwrought vegetable or animal fibre has been presented to notice; subsequently the machinery by which it was operated upon in the factory; after this, the product of the manufacturer; and, in the Class under consideration, its application to those wants for the supply of which the fibre itself is principally valued.

The title of the Class will suggest the multifarious objects which fall naturally within its comprehensive limits. The Sub-Classes are as follows:—A. Hats, Caps, and Bonnets, of various materials; B. Hosiery, of Cotton, Woollen, and Silk; C. Gloves, of Leather and other materials; D. Boots, Shoes, and Lasts; E. Under Clothing; F. Upper Clothing.

In the Building those who are specially interested in these articles will meet with them displayed in a variety of cases, and in other ways, in the South Transept Gallery.

The manufactories of hosiery, straw plait, and boots and shoes, have a local establishment in this country which is deserving of attention; that of hosiery is principally confined to Derby, Nottingham, and Leicester. Cotton hosiery is chiefly made in Nottingham, as also is the silk hosiery; the latter being likewise largely conducted in Derby. Woollen hosiery is most extensively produced in Leicestershire. The statistics of these trades have been carefully prepared and are very interesting. The annual value of cotton hosiery is taken at 880,000*l.*; that of worsted, &c. is 870,000*l.*; and of silk 241,000*l.* In the manufacture of these goods it is estimated that 4,584,000 lbs. of raw cotton wool are used—6,318,000 lbs. of English wool and 140,000 lbs. of silk. The total number of persons deriving support from this manufacture is about 73,000, and about 1,050,000*l.* of floating capital is considered to be employed in the various branches of the trade.

The manufacture of straw-plait is carried on chiefly at St. Albans, Dunstable, Tring, and a few other places. That of boots and shoes is conducted on a very large scale at Northampton, from which place vast quantities of these articles are sent out ready for wear. Worcester, Dundee, and Woodstock are celebrated for their glove manufactures.

It is interesting to notice among the variety of objects exhibited in this Class, the ingenious and patient efforts made to apply to economical purposes, materials derived either from the vegetable or animal kingdoms. New uses of known materials are shown—and, more importantly, the use of new materials. The introduction of such materials is always slow and difficult, but is ultimately certain, if they are found to fulfil the indications which are considered as first requisites in a substance to be used by the manufacturer.—R. E.

1 BUCKMASTER, WILLIAM, & Co., 3 *New Burlington Street*—Designers.

Court suit, in detail; proposed as a substitute for that now in use.

Chaco, as at present worn by infantry of the line.

New head-dress for infantry of the line, adapted to various climates; fitting to the head with equable pressure, and with adjusting ventilator, proposed as a substitute for the chaco now in use.

Undress coat for officers of the line, proposed as a substitute for the shell jacket.

2 FOSTER, PORTER, & Co., 47 *Wood Street, Cheapside*—Manufacturers.

Specimens of fawn-skin and cape driving gloves and gauntlets. Plumage plush, regal velvet, patent plush

taffeta, and other new fabrics in gloves and gauntlets. Lace mitts, machine made. Silk half-hose, embroidered by hand. Polka jackets, in new shapes and patterns, made by machinery, and very superior in finish to those made by hand. Specimens of children's hoods, boots, bootakins, and gaiters. Samples of Scotch hosiery, of superior texture and finish.

[Gloves are of great antiquity in this island, as the word is evidently derived from the Anglo-Saxon "glof." They are not mentioned in Scripture; but were in use among the Romans in the time of Pliny the younger. Xenophon states, that their use among the Persians, was considered a proof of their luxurious habits. Gloves have had many symbolical meanings. The gauntlet, or

glove, thrown down, was a mode of challenge; and still is practised as one of the forms at a royal coronation. Queen Elizabeth, it is well known, was very fond of gloves, of which numerous presents were made to her. White gloves are also presented to the Judges on occasion of a maiden assize, the exact significance or origin of which practice has never been satisfactorily explained. Leather gloves are now made at Worcester, Yeovil, Woodstock, and London; and were formerly made at Leominster and Ludlow, but the trade in the latter places is quite decayed.]

3 TAYLOR, WILLIAM GEORGE, 285 *Regent Street*—
Proprietor.

Balbriggan lace-stockings, of fine texture and elaborate patterns. Balbriggan stockings, of the full size, weighing 9 ounces.

Lambs-wool stockings, knitted by the hand at Ballindine, Mayo, Ireland.

Specimens of hand-knitting, in hosiery, by children at Ballindine, exhibited for regularity and workmanship.

4 HALL, J. SPARKES, 308 *Regent Street*—Manufacturer.

Elastic stocking-net boots, elastic webbing, and improved elastic materials for boots and shoes.

5 PEART & DOSSETOR, 12 and 13 *Poultry*—Inventors.

Four-threads cotton glove half-hose. Patent Angola and silk glove half-hose.

Ladies' four-thread glove hose. Black and white silk glove hose.

Cotton and woollen drawers, with elastic ribbed cotton gussets.

Railroad caps and protectors. Improved nightcaps. Silk shirt fleeced, for rheumatism. Fine real Welsh flannel. Silk and Segovia half-hose. Improved worsted braces, with broad shoulder-plates.

6 POPE & PLANTE, 4 *Waterloo Place, Pall Mall*—
Manufacturers.

Specimens of hosiery. Beaver fur stockings, and scarf, made on the hosiery frame.

Registered elastic netted corsets, of silk and caoutchouc. Elastic netted belt, stockings, socks, leggings, and knee-caps. Cotton and silk stockings, and other apparel.

7 NEVILL, J. B. & W. & Co., 11 *Gresham Street West*—
Manufacturers.

Men's cotton half-hose; striped various, made principally for export; striped red and blue, superior colour and manufacture; and made colours.

Women's white linen thread hose, and men's linen thread half-hose, made from Irish flax.

Gentlemen's imitation silk thread half-hose and caps, solid colours; and cotton half-hose, pink.

Ladies' imitation silk thread hose, fine, very fine, and coloured; the same, open-worked very fine, and cotton improved pattern.

Gentlemen's open-worked caps for warm climates and summer wear.

Ladies' white cotton hose adapted for Spain and South of Europe; white hose manufactured from Colonial cotton, of improved elasticity; and patent black cotton hose, colour fast and clean.

Men's white cotton pantaloons drawers with improved broad linen waistbands.

Ladies' white cotton chemises manufactured with improved sleeves and shoulder portion in a superior manner throughout.

Gentlemen's stout merino wool pantaloons drawers, with supporting elastic knee.

Ladies' extra fine Australian wool waistcoats, with long sleeves, &c., improved in softness and preparation, pink and scarlet.

Ladies' cotton waistcoats, improved shapes, light and durable.

Gentlemen's mixed silk and Australian wool under waistcoats, improved shapes, light and warm.

Ladies' extra fine merino wool hose, improved elasticity, warm and free from shrinking; and gentlemen's half-hose of the same wool.

Gentlemen's cotton hose with mixed silk and wool ankles.

Ladies' fine mixed silk and wool hose, superior frame work.

Ladies' superfine bleached and unbleached cotton waistcoats, improved shapes and manufacture: these are shaped in the frame to any size and figure.

Men's stout and fine unbleached cotton pantaloons drawers, new ribbed waistbands, and double frame-worked substance.

Ladies' extra fine Australian wool and fine Cashmere wool under waistcoats.

Gentlemen's fine Cashmere wool under waistcoats, improved in softness.

Men's stout worsted and extra fine worsted under waistcoats.

Men's striped shirts or Guernseys for export or seamen's use.

Men's white cotton half-hose, and brown cotton half-hose, various qualities. Ladies' cotton hose, rose colour.

8 GREGORY, CUBITT, & Co., 15 *Aldermanbury*—
Importers and Manufacturers.

Straw, from the wheat rick; cut into lengths and sorted into sizes; washed and bleached, for cutting into splints; and cut into splints, for plaiting.

Plait, made from the whole pipe-straw, called whole straw-plait; made from the straw cut into splints, called split straw-plait; and made from the splints united, called patent straw-plait.

Bonnet, made from the whole pipe-straw, called "whole straw" bonnet; made from the split straw-plait, called "split-straw" bonnet; and made from the plait, with the splints united, called a "patent straw" bonnet.

Specimens of different kinds of straw-plaiting, viz. cord, whole straw, cord patent, China pearl, &c.

Plait, made from the splints, with the straw reversed, called "rice patent plait."

Various kinds of rice plait.

Bonnet made from rice patent plait.

Tuscan grass, as imported; as cut into lengths, and sorted into sizes; and as washed and bleached, and prepared for plaiting.

Plait made from the stem of the Tuscan grass, called "dark Tuscan plait;" and made from the upper part of the grass, called "light Tuscan plait."

Bonnet made from the dark Tuscan plait.

Hat made from the light Tuscan plait.

Specimens of the various kinds of Tuscan plait.

Block of wood, as cut from the poplar tree; as cut into splints for plaiting; the splints washed and bleached for plaiting.

Specimens of various kinds of plaiting, from the splints called "British chip plait."

Bonnet made from a piece of the same, called "British chip bonnet."

Block of wood from the willow tree; as cut into splints, for weaving into square sheets; the splints washed and bleached, prepared for weaving.

Specimens of willow square sheets, from the loom.

The willow shape, for the foundation of silk bonnets.

White willow bonnet; coloured willow bonnet, made from the sheets.

Straw splints, for weaving into trimmings.

Specimens of straw trimmings; the loom in which they are made.

Bonnet, made from the straw trimming.

Horse-hair in its rough state; and washed and bleached for weaving into trimmings.

Specimens of horse-hair trimming. Bonnet made from it.

Flag-grass, as imported from Cuba; and as washed, bleached and cut, prepared for plaiting; hats, from the same, called "Brazilian hats."

[Plait-straw is the straw of the wheat plant, selected especially from crops grown on dry chalky lands, such as those about Dunstable. The middle part of the straw above the last joint is selected; it is cut into lengths of eight or ten inches, and these are then split. The Leghorn or Tuscan plait is the straw of a variety of bearded wheat, grown expressly on poor sandy soils, pulled when green, and then bleached. Other kinds of the grass tribe, besides wheat, furnish straws available for plait-work.—E. F.]

PRICE & HARVEY, 6 *Pilgrim Street, Ludgate Hill, and Tottenham*—Inventors and Manufacturers.

The white bonnet, patented by the exhibitor, which will clean, and alter to any shape, and look equal to new.

The registered carriage bonnet, composed of crape lisse, with tufts of silk, worked by the needle, in all colours.

The dress opera bonnet, composed of gauze and ribbon of peculiar make.

Bonnet composed of ribbon and aroephane, for the carriage or promenade.

10 FIELD, JAS., & SONS, 114 *Fore Street, Cripplegate, and Harpenden, Herts*—Manufacturers.

Improved Dunstable bonnet; twisted edge whole pipe Dunstable; split straw bonnet; double split straw, called a patent Dunstable; rice straw bonnet, plaited with the rough side out; satin straw bonnet with rock edge; fancy crochet and black and white fancy mixed bonnet; black and white satin and fancy rock mixed bonnet.

Straw bonnets in new designs and combination of materials. Specimen of wheat straw from which pipes are drawn for plaiting; and of the inner pipe drawn from the wheat straw.

Machine for splitting straws of various degrees of fineness.

Ubleached straw plaiting; the same, clipped and bleached; block of wood of the poplar-tree; bleached shavings of the same for plaiting.

Black and white satin and crimped split straw Chinese hat.

Black and white crochet and split straw "Duc d'Aumale" hat.

Green and white ladies' crimped hats.

[The straw-plait manufacture has had its local establishment in England about eighty years, and is now carried on principally in Bedfordshire, Herts, and Buckinghamshire: at Dunstable this manufacture has long been successfully prosecuted, and employs large numbers of individuals. The name of this town has been connected with that of its productions, and used to characterise certain descriptions of straw-plait. "Whole Dunstable," signifies that the plait is formed of seven entire straws, and "patent Dunstable," that it consists of fourteen split straws. This last manufacture has been introduced about half a century. The splitting of the straw is effected by the machine exhibited.—R. E.]

11 VYSE & SONS, 76 *Wood Street*—Manufacturers.

Ladies' bonnets of finest quality, produced from wheat-straw, plaited and made up by the hand.

Split; fancy, Alboni edge; patent rice, fancy split, embroidered Tuscan edge.

Ladies' bonnets of fancy horse-hair and straw: black—horse-hair, blonde, and straw; white—horse-hair, blonde, and straw; blue—horse-hair and blonde; white—horse-hair and blonde; goffered—horse-hair and straw-plait. The material made by the loom, and sewn into bonnets by the hand.

Leghorn bonnets made of material produced in Italy.

All of British manufacture.

12 WELCH & SONS, 44 *Gutter Lane, Cheapside*—Inventors and Manufacturers.

1. Staple article, wheat straw.
2. Straw pipes as prepared for plaiters' use.
3. Straw splitters and splittings.
4. Specimens of straw plaits.
5. Goffered split straw bonnet.
6. Fine patent bonnet in fancy design.
7. The original split straw bonnet, consisting of 140 yards of plait, which required 292,320 operations in plaiting during seven weeks, and took ten days in sewing.
8. Split straw bonnet with goffered design.
9. British Italian split straw bonnet.
10. Fine patent fancy bonnet.
11. Mourning fancy straw bonnet.
12. Fancy straw exhibition edge.
13. Child's rice patent bonnet.
- 14—17. New lace fancy bonnets.
- 18—23. Crinoline and lace fancy bonnets.
- 24, 25. Crinoline fancy bonnets.
26. Leghorn and lace fancy bonnet.
27. Tuscan and lace bonnet.
- 28—30. Girls' fancy hats.
31. Girl's gipsy bonnet.
- 32, 33. Boys' straw hats.
34. Infant's rice straw hat.

13 ALLAN, JAMES, 158 *Cheapside*—Manufacturer and Designer.

Split straw bonnet; design formed by hand. White Italian chip; prepared and manufactured in England, Hair and chenille—English. Goffered crinoline and straw; English. Crinoline and cordonnnet; design formed by hand.

Bedford straw. Goffered straw. Rice straw. Dunstable straw. Choice specimen of whole straw, plaited by an old woman 80 years of age.

Embroidered crape bonnet. Boy's rice straw hat. Young lady's hat. Tuscan hat, with painted satin trimming.

14 SPURDEN, WOOLLEY, SANDERS, & Co., 42 *Friday Street*—Manufacturers.

Bonnet, exhibited for colour, design, and execution.

Bonnet, made of English split-straw plait, exhibited for manufacture and workmanship. Made by hand labour; it occupied 48 hours in making; and, though containing 90 yards of plait, is very light.

Bonnet, made of English plait, showing the inner side of the straw.

15 WOODHOUSE & LUCKMAN, 33 *Wood Street, Cheapside*—Designers and Manufacturers.

Bonnets, manufactured from the English willow-tree, exhibited on account of their lightness and moderate cost. The crystal bonnet.

16 WINGRAVE & SONS, 62 *Wood Street, and at St. Albans*—Manufacturers.

- Variety of bonnets and hats.
- Whole straw bonnet.
- Split straw hat double and single.
- Inverted straw hat, commonly called rice.
- White and coloured willow hats.
- Straw and willow hats, mixed.
- White willow and palmetto leaf hats.
- Palmetto leaf and straw hat, mixed.
- Double split straw hat.
- Tuscan straw hat.
- Palmetto leaf matting.
- Palmetto leaf and straw hassock.
- Palmetto leaf ladies' work-basket.

[A variety of different materials have been employed at different times for the manufacture of bonnets and hats. Wheat straw, grown in different localities, possesses, different characteristic qualities, which render it adapted for the finer or for the coarser descriptions of straw-plait

manufactures. The inversion of the straw gives to the plait a peculiar appearance, which has commonly led to the opinion that a different material has been employed. The palmetto leaf, and the willow hats and bonnets, exhibit some recent applications of new materials for this purpose.—R. E.]

16A LONG, GEORGE, *Londwater, Wycomb, Bucks*—
Inventor, Designer, and Manufacturer.

Hats and bonnets made upon a lace-pillow—1. Straw plait and silk. 2. Horse-hair. 3. Manilla hemp. 4. Twisted grass. 5. Straw and silk. Designs registered by the exhibitor.

17 HOMAN & Co., 39 & 40 *Chiswell Street, Finsbury*—
Manufacturers.

Printed regatta and other shirts; flannel vests; braces; purses; riding belts; garters, &c.

18 PHILLPOTTS, MARY ANNE, 37 *North Audley Street*—
Proprietor.

Figure of a lady in full court dress, in the reign of Her Majesty Queen Victoria, 1851.

19 PATERSON, J., *Wood Street, Cheapside*—Manufacturer.

Fancy cravats. Black satin stocks. Improved braces, belts, collars. Shirt front, plaited in the loom.

20 NEVILL, ALFRED, & Co., 121 *Wood Street, Cheapside*—
Producers.

A piece of Irish linen made from the finest flax. A shirt, shirt-front, and collars, made from the above piece of linen. Richly embroidered neck-tie.

21 CAPPER & WATERS, 26 *Regent Street, St. James's*—
Inventors and Manufacturers.

Twelve shirts, all differing in form, including registered inventions, and of varied substances, in linen, cotton, wool, and silk, viz. corazas, giubba, frock, hunting, Canadian; tourist sottanello; opera, embroidered; court, new form of frill; fatigue, elastique respirante; Carlisle jacket; sottanello, single and double breast. Dressing gown, with trousers à la Turque. Detached shirt-fronts and collars, various.

22 ABLETT & WHEELER, 234 *Regent Street, and*
23 *Poultry*—Manufacturers.

Shirt of peculiar construction, without buttons. Child's jacket, pair of gaiters, and pair of gloves, exhibiting specimens of English embroidery.

23 REID, W., 51 *Conduit Street, Hanover Square*—
Inventor and Manufacturer.

The registered "sans-pli" shirt.

24 BRIE, JOSEPH, & Co., 189 *Regent Street*—
Producers and Designers.

Shirt fronts, including the newest patterns, in runnings, stitchings, veinings, and embroidery. Shirts of an improved cut. Embroidered handkerchiefs and flannel waistcoats.

25 MARSHALL, WILLIAM, 80 *Regent Street*—
Inventor and Manufacturer.

Registered improved shaped shirt, cut to fit the shoulders, &c.

26 POWELL, S., 52 *Regent Street*—Inventor and
Patentee.

Bisunique, or reversible garments, coats, vests, trousers, paletots, &c. The royal bisunique jacket, constructed of cloth which has two distinct faces of contrasting colours, in one fabric.

27 BARNES, THOS. & GEO., 9 *New Court, Goswell Street*—
Designers and Manufacturers.

Registered buckskin braces, of new and old designs; exhibited as specimens of execution; the improvement consists, partly, in the attachment of the vulcanized India-rubber spring by adhesion. Flexible razor straps.

28 HEMMING, EDWARD, 6 *Piccadilly*—Designer.

A model shirt, intended, by its peculiar shape, to adjust itself to the body and neck. Made of fine Manchester long cloth and Irish linen.

29 SMITH, JOHN E., 3 *Lawrence Lane*—Manufacturer.

Shirt, formed without the aid of seams or gathers. Specimen of Moravian needlework, illustrating the growth of flax; with the rose, shamrock, and thistle.

30 PORTER, THOMAS, 94 *Strand*—Manufacturer.

Specimen of a shirt cut on mathematical principles.

31 WAGNER, LOUISA & MARIAN, 35 *Doddington Grove*—
Designers and Manufacturers.

Plume of registered feathers and rosettes, in coloured mohair silk. Hand-netted silk handkerchief head-dresses; the same in floss silk, with lappets.

Fancy bracelets, of various designs, produced by hand from common braid. Fancy silk (all hand-netted) dress caps. Hand-netted Florence-pattern berthe, and dress sleeves made of plain silk twist and fancy floss silk. Neck-tie of same material, *en suite*. Dress, opera, and ball caps, assorted, of gold, silver, and chenille. English mohair crocheted morning, smoking, or reading caps.

32 ATLOFF, JOHN GEORGE, 69 *New Bond Street*—
Inventor.

Ladies' shoes of various materials. Silk slippers, embroidered in gold, with the Queen's arms.

Ladies' silk boots. Ladies' half boots.

33 WEATHERHEAD, HENRY, 27 *Panton Street,*
Haymarket—Manufacturer.

Silk and India-rubber braces. Gros-de-Naples belt, with silk and India-rubber springs.

34 NICOLL, BENJAMIN, 42 *Regent Circus, and* 46
Lombard Street—Manufacturer.

Shirt of a new material, in silk. Shirt of Irish linen. Hunting shirt.

35 CHRISTYS, 35 *Gracechurch Street, London, and Stock-*
port, near Manchester—Hat Manufacturers and
Hatters' Furriers.

Specimens, illustrating the manufacture of hats, consisting of materials in the raw state, prepared for use, and in the different stages of manufacture, up to the finished state.

Beaver.—Beaver skin, dark colour; the same with the coarse hair taken off. Beaver skins, silvery colour; the same with the coarse hair taken off one side, with the fur partly cut off by the cutting machine. Musquash skin; the same with coarse hair taken off. The preceding are the produce of the Hudson's Bay Company's territories.

Newtria skin, as imported from Buenos Ayres; the same with the coarse hair taken off. Vicuna skin from the Andes, as imported from Lima. Rabbit skins—home. Hare skins—home and Turkish.

Machine for cutting the fur off the skin, by passing it stretched through rollers over a sharp blade, against which it is struck by the fall of an iron beam worked by a crank, and so adjusted as to cut off the fur without cutting through the felt.

Materials as prepared for use.—Beaver furs as cut from the skin, and as prepared for use, the coarse hairs being taken out by machinery. The coarse hairs as taken out. Newtria, musquash, hare, and rabbit furs, natural and prepared for use.

Wools—English, Spanish, Saxony, Australian, and Vicuna wools; the same washed and carded.

The manufacture of felt hats is illustrated in the following specimens:—The fur for the body of a hat before felting as first formed by the workman with the vibration of a bowstring; in the first stage of felting; and completely felted. The hat body stiffened with waterproof composition prepared from materials. The beaver fur as prepared for putting on the body to form the nap, and mixed with cotton to prevent the outside covering of the beaver from felting together instead of adhering to the body; the same, in the first stage of sticking. The hat after the nap is felted on, by rolling in boiling water, and showing the vegetable substance (the cotton), separating from the animal substance (the beaver), which has adhered to the body. The hat in the cone completely napped and cleared from the cotton by a process of combing. The hat undyed after shearing by machinery and blocking into form. The hat dyed with materials. The hat in completed state, after being blocked by steam, finished, trimmed, and shaped for wear. Specimens of hats of felted fur in the various materials, forms, and colours, as made for home and foreign trade.

The manufacture of silk hats is shown in the following specimens:—The silk in the raw as imported, and as dyed. The velvet plush as woven, and as finished for use. The foundation or body of the hat, showing the arrangements at the top for ventilation, and at the brim, to prevent the moisture from the head passing through to the silk on the outside. The hat in the completed state.

Hats of old manufacture; illustrating the change of shape and improvements in make, during the past sixty years, arranged in decennial periods. The cocked hat bears the stamp of the government (internal) duty of 3s. 6d. then levied on hats of home manufacture above the value of 18s.

Tools used in the manufacture of hats.

[The manufacture of silk hats has attained a condition of vast importance. The material employed to imitate the fur is a silk plush, manufactured to a large extent in England for the express purpose. It is estimated that about 250,000 dozen silk hats are made in London, Manchester, Liverpool, Birmingham, and Glasgow. The annual value of silk hats produced in England is estimated at about 900,000l.]

36 FORD, RICHARD, 185 *Strand*—Manufacturer.

Shirt, exhibited for plain needlework, and improved form.

37 GLENNY, CHARLES, 33 *Lombard Street, City*—Proprietor.

Cotton hosiery. Ladies' stockings, fine, four threads, six threads heels and feet, weighing only seven ounces. Medium quality, stout, seven threads, nine thread heels and feet. Gentlemen's fine half hose. Manufactured at Balbriggan, in Ireland, where the cotton undergoes a preparation which imparts to it softness and elasticity.

38 SANDLAND & CRANE, 55 *Quadrant, Regent Street*—Inventors and Makers.

Belt drawers, exhibited on a statuette. Shirt exhibited on the same statuette.

39 BRADSHAW, G., 103 *Bishopsgate Street Within, and 25 High Street, Islington*—Inventor and Patentee.

Patent fastening, as applied to gentlemen's collars of various shapes; a simple, yet speedy mode of fastening, superseding strings, loops, and other objectionable contrivances.

The same applied to gentlemen's fronts and stocks, or once-round cravats.

Gentlemen's anti-rheumatic belt and drawers. This fastening regulates the size, gives support to the wearer, and is of advantage in hunting, riding, or rowing.

Waistcoat with the fastening, which keeps the garment in an easy and graceful position. The fastening can be taken out while the waistcoat is being re-dressed.

40 JOUBERT, CAROLINE, 8 *Madrox Street, Hanover Square*—Inventor and Manufacturer.

Self-adjusting white watered corset, with a spring busk and improved lacing.

Elastic corset belt, for invalids; made of India-rubber tissue, of French manufacture.

40A ROBERTS, GEORGE, 183 *Oxford Street*—Manufacturer.

Corset made in 21 pieces, all cut "on the cross," upon the expanding principle, with instant relieving backs; corset, made to fasten in the front with patent spring clasp, and gauze elastic sides; corset, of the most simple construction, with patent spring backs, no lacing being required.

41 PIPER, THOMAS FOOT, 4 *Bishopsgate Street Without*—Inventor and Manufacturer.

Mechanical spring-corset, silk bodice, simple bodice, and young ladies' scapular or contractor.

42 MARTIN, EMMA & ELIZ. H., 504 *Oxford Street*—Designers and Manufacturers.

Elastic bodice of white satin. The elasticity is produced by the introduction of vulcanized India-rubber in the back and sides, to render them expansive. Exhibited on an expanding bust, to show the utility of this invention for free respiration.

Riding bodice, of similar materials. The simplicity of the fastening, the absence of whalebone and lacing, and the shape, distinguish the elastic bodice from stays.

Abdominal belt, peculiar in its softness and elasticity.

43 SYKES, MARY E., 280 *Regent Street*—Inventor and Manufacturer.

Corset, weighing only five ounces: the elastic portion made by hand; the mode of fastening and unfastening is new.

44 DEVY, ELIZA, 73 *Grosvenor Street*—Inventor and Manufacturer.

New registered riding stays. Nursing stays. Dress stays, and stays of the usual kind.

45 CAPPER, JOHN, & SON, 69 *Gracechurch Street*—Part Inventors and Makers.

Registered folding bassinets or cradles, intended to facilitate the packing and carriage of infants' bedding.

Infant's basket, with its contents. Infant's clothing, assorted. Night-cap and dress. All trimmed with Irish lace.

46 THOMAS, W., & BROTHERS, 128 & 129 *Cheapside*—Manufacturers.

Boots and shoes made without stitches, pegs, nails, or rivets; with heels on an improved principle. Boots with leather soles; with gutta percha soles; and with gutta percha soles with leather edges, which prevent the gutta percha from spreading and turning up at the edges. Boots with gutta percha waist and leather sole; boots with leather waist and gutta percha sole.

Improved heels; the same, attached to soles of various sorts. Boots and shoes, with elastic sides, made by sewing pieces of India-rubber to the upper leather and then to the sole.

Boots for persons with tender feet, or invalids, with the inner sole of spongy India-rubber. Spongy shoes. Ladies' boots, with Fisher's patent elastic spring backs. Drawing-room slippers, made without seam.

Stays, made without seams, known as "Paris woven." Silk. Thread. Patent woven elastic corset, having elastic threads introduced into the fabric. Webbing or tape for Venetian blinds, safety carpet and leathern bags. All patented.

46A SHREEVE, Mrs., *Charing Cross*—Inventor.
Elastic knitted corset.

48 JOHNSON & Co., 113 *Regent Street*.—Patentees.
Patent ventilating hats. The principle of ventilating these hats being to admit the air through a series of channels cut in thin cork, which is fastened to the leather lining, and a valve fixed in the top of the crown, which may be opened and shut at pleasure to allow the perspiration to escape.

Patent valves. Patent leather. Full-dress court hats. Royal state livery hats. Ladies' riding hats, &c.

Field-marshal's, general's, and colonel's full-dress regulation cocked hats.

Admiral's, captain's, and lieutenant's full-dress regulation cocked hats.

[The general principles upon which a hat is made, are of a most imperfect description as far as relates to the comfort and probably, in a degree, to the health of the wearer. It has been conjectured that one among other causes of premature baldness, is the deficient ventilation, and the undue contraction of the rim of most hats. In the present instance an attempt to obviate these defects is exhibited.]

49 GEARY, NICHOLAS, 61 *St. James's Street*—
Inventor and Manufacturer.

Improved and elastic corsets, for full-dress and other purposes.

Elastic supporting-belts.

Spinal supporting-corset, with invisible spring-crutch. Invalids' self-acting corset, with a plan for instantaneously unfastening the corset without unlacing (in case of sudden indisposition). Perforated gossamer corset, for hot climates, &c.

Hydropathic belt, constructed for equal pressure and support of the "unschlag," or compress, when worn round the body.

50 DANDO, SONS, & Co., 42, 43, 44 *Cheapside*—
Manufacturers.

Specimens of a new description of patent light network velvet hats, in various stages of manufacture. The foundation, or body, is made of net, which allows free ventilation; it weighs one ounce and a half.

51 WHITE, WILLIAM, 68 *Cheapside*—Manufacturer.

Ventilating velvet-nap hats, and zephyr hats.

51A FELIX, EDWARD & Co., 10 *Cheapside*—
Manufacturers.

Hats of a peculiar construction, designed to render them elastic, waterproof, and ventilating.

52 ASHTON, JOSEPH, & SONS, 55 *Cornwall Road*—
Manufacturers and Inventors.

Black and drab patent elastic beaver hat on beaver body. Beaver felt hat, natural colour of the wool.

Black beaver felt hat; beaver body.

Light elastic velvet hat, on a gossamer body; French plush.

Light elastic hat, on a stuff body, French plush.

53 ASHMEAD & TYLER, J. T., 7 *Mommt Street*,
Berkeley Square—Inventors and Manufacturers.

Patent folding hat, without springs. Soft velvet folding hat. Minerva hunting cap.

54 MELTON, HENRY, 194 *Regent Street*—Manufacturer.

Gentleman's hat of the ordinary size, made of English plush. The weight does not exceed three ounces.

The plush was produced from the manufactory of Stephen Walters and Son, Finsbury.

Lady's riding-hat, made of English plush, and of new design.

55 SMITH, GEORGE, & Co., *Union Hall, Union Street*,
Borough—Inventors and Manufacturers.

Light silk hat. Silk hat, the body of which is made on a new principle. Silk hat on soft felt body. Hat of a new shape. Ladies' riding hat, new shape. A gossamer body japanned by means of a new process; intended for sailors or others exposed to hot or cold climates.

56 DIETRICH, FREDERICK AUGUSTE, 2 *Bennett Street*,
Blackfriars Road—Inventor and Manufacturer.

Patent elastic hat lining; invented to prevent pressure, to retain a firm hold, and permit free ventilation.

Newly-invented silk hat, the body of which, being composed of horsehair, is porous and elastic, ventilating and flexible.

New military cocked hat, made from the same material. Gentlemen's court hat, and ladies' riding hat, made from the same material.

57 BARBER, SAMUEL, *Brentford*—Inventor and
Manufacturer.

French silk hat, with body of Manilla grass, exhibited for novelty, durability, ventilation, waterproof, and other qualities.

58 STAINBURN & BAUGH, *Gresham Street*—
Manufacturers.

Specimens of felt materials: English rabbit's fur, 8 parts; Saxony lamb's wool, 3 parts; Llama, or red wool, 1 part; weighing together 1½ oz.

The same, formed into a hollow cone by a process called boring; the mixture and coherence of the fibre thus produced is the first stage in the felting process.

A felt body (being the cone required for a hat), worked to the proper size and texture; heat, moisture, pressure, and friction being the means by which it is perfected.

A felt body, waterproof, stiffened with resinous gums dissolved in spirit.

A beaver cover, which, when worked into a stiffened body, is called a hood.

The beaver hood, ready for dyeing.

A dyed or black hood, which, softened by a jet of steam, is drawn upon a block, and finished to the precise size and style required.

Flexile felt hats.—Silk hat, made from English plush.

Felt body prepared for covering. Silk cover.

Silk hat complete, new style.

59 ZOx, LAMEN, 84 *Long Acre*—Manufacturer.

Registered Korychlamyd, or helmet cap. Patent aquatic naval life-cap. Folding college cap. Racing, opera, and military caps.

60 GROSJEAN, FREDERICK, 109 *Regent Street*—Inventor.

Invention for producing a red stripe on regimental trousers, without the usual process of sewing one piece of cloth on another.

Plan for securing money deposited in the pockets of trousers.

Method of instantaneously detaching the skirt from the body of a lady's habit, by a spring fastening.

Invention for excluding the cold air from the legs and feet of travellers.

61 GARRARD, ROBERT & JOHN, *Loman Street, Southwark*—
Manufacturers.

Japanned leather peaks for caps. Registered japanned felt hat. Fireman's japanned leather helmet. Leather straps, cockades, &c. Models of japanned felt hats, of different shapes.

62 THOMPSON & SON, 11 *Conduit Street*—Designers and Manufacturers.

Morning jackets. Scarlet hunting coat. Cricket jacket and trousers. Waistcoats. Ladies' polka braided.—All of elastic webbing, of British manufacture.

63 WALKER, BABB, & Co., 346 *Strand*—Inventors.

Registered waterproof alpaca over-coat and case; the seams in back and front of the arms are dispensed with: it is light in weight, and can be carried in a coat pocket.

64 CODY, JOHN, 6 *Marshall Street*—Inventor.

The "monomeroskiton," or single-piece coat; a fine dress coat of British manufacture, constructed from one piece of cloth.

64A BRAUN, LOUIS, 65 *Wood Street, Cheapside*—Manufacturer.

Fancy caps of various sizes.

65 KISCH, SIMON A., 250 *Regent Street*—Inventor.

Registered auto-crematic gown, with elastic springs and peculiar configuration of the neck, which prevent it from falling off the shoulders.

Cassock waistcoat, answering the purpose of a waistcoat and short cassock.

66 BRAUND, JOHN, 26 *Mount Street, Grosvenor Square*—Producer.

Travelling cap, with transparent peak, to protect the eyes from wind, dust, &c., without obstructing the vision. Manufactured by Messrs. Christy and Co., Gracechurch Street.

67 LYONS, J., 12 & 13 *Artillery Place, Woolwich*—Producer.

Military caps.

68 PRICE, WILLIAM, 115 *Chancery Lane*—Designer and Manufacturer.

Flexible spring gowns; law, clerical, and civic.

69 CUTLER, WILLIAM, 25 *St. James's Street*—Inventor.

The "duplexa," or morning and evening coat; intended to answer the purpose of two garments of opposite character.

70 BAIN, WILLIAM, 141 *High Holborn*—Inventor.

Floatable life-preserving cape cloak.

71 SMITH & GIBBS, *Wellingborough, Northamptonshire, and 84 Cheapside*—Inventors and Manufacturers.

Cloth and leather gaiters, with patent fastenings, &c.

Patent Euknemida, in cloth and leather, various. A new mode of fastening, adapted to various articles, as stays, ladies' dresses, &c.

Cambridge over-coat waterproof in a new style.

National cape and travelling wrapper. Registered for novelty, shape, and reversibility.

Hats new in shape and material, called "Novum Pileum."

Silk elastic webbings and sandalings; exhibited for colour and quality.

Youths' leggings, new cut and coloured material.

72 GATES, LAURA CHARLOTTE, *Upper Eaton St., Pimlico*—Inventor.

Model of married lady's dress, with improvements which can be applied to dresses already made.

73 HURLEY, DANIEL, 10 *Hare Court, Aldersgate Street*—Inventor and Manufacturer.

Lady's safety pocket, which cannot be picked or cut from the person without the wearer's knowledge.

Model of a pair of trousers, so constructed that they may be worn three different ways, either as a French bottom, or gaiters attached, or plain bottom, with improvements.

74 CAHAN, EDWARD, 371 *Strand*—Designer.

The "Anaxyridian" trousers. The peculiarity consists in the cut, which is so arranged that they remain as a fixture to the heel without straps; and dispense with braces.

75 SHINTON, R., 29 *Spencer Street, St. George's East*.

A pocket protector.

76 BETHEL, WARE, & Co., 62 *Aldermanbury*—Manufacturers.

Camellia in vase, leaves of Luton plait. Flower of chip imported from Italy. Vase of variegated Luton plaits.

Young lady's hat, fancy Devon plait.

Lady's riding hat, patent Luton plait.

Boy's hat, fine Devon plait.

Infant's hat, patent Luton plait.

Gentleman's hat, broad Luton plait.

Ladies' bonnets, including patent Luton plait in wreaths; convolvulus leaves of Luton plait; flower and insertion, Italian chip. Beetles' wings, coloured Luton plait. Primroses, leaves Luton plait, flowers Italian chip. Italian chip in wreaths. Whole Dunstable plait. Plain Luton plait. Plain-sewn chip; material imported from Italy. Broad Luton plait.

[The plait, technically called "Luton plait," is made in imitation of the "whole Dunstable" plait. It consists of double seven straws, and is a coarser kind of material than the Dunstable. Its application to the manufacture of ornamental articles is illustrated in the articles exhibited. It deserves notice, that of late an increase in the import of unmanufactured material (straw, &c.) from Italy has taken place, and has been accompanied by a corresponding decrease in that of manufactured articles in plait. The plaiting of foreign material is carried on to a large extent in this country.]

77 ROBERTS, EDWARD BOYD, 239 *Regent Street, and 32 Moorgate, City*.

The beaver (*Castor fiber*), applied to articles of clothing.

78 DENT, ALLCROFT, & Co., 97 *Wood Street*—Manufacturers.

An assortment of ladies' and gentlemen's gloves, of various materials, colours and styles. Ladies' drab kid gloves, sewn, and fancy colours, &c.; pointed, fancy Florentine; and black kid, with fancy sewings.

Gentlemen's drab and coloured kid gloves, Dundee sewn; black calf gloves, tan sheep gloves, for driving.

Ladies' and gentlemen's white, drab, and real fawn gloves.

Ladies' and gentlemen's coloured kid gloves, lined chamois and pink silk, and a variety of other gloves.

79 THRESHER & GLENNY, 152 *Strand*—Manufacturers.

Thresher's India gauze waistcoats. Silk and thread hosiery. Silk and lambs'-wool hosiery. Improved spun-silk hosiery. Specimens of the respective qualities of silk hosiery. Gauze spun-silk waistcoats, exhibited as specimens of spun silk for under clothing. Gauze merino waistcoats. Hand-spun silk hosiery, exhibited as a specimen of hosiery, made from waste silk.

80 BALL, WILLIAM Y., & Co., 32 *Wood Street, Cheapside*—Manufacturers.

Kid leather gloves, cut and made in England; manufactured from French dressed kid skins.

A glove in its unfinished state.

81 LART, JOHN, & SON, 116 Wood Street, Cheapside, and Rutland Street, Nottingham—Inventors and Manufacturers.

Ladies' Lisle thread hose, in plain and open work, of new patterns; manufactured at Nottingham. Ladies' silk jacket, trimmed, woven and fashioned in the stocking frame; manufactured at Nottingham. Gentlemen's cotton and silk pantaloon drawers, with elastic washable gussets; and various specimens of gentlemen's cotton and spun silk half hose, and children's socks, and gentlemen's merino, Cashmere, and spun silk vests.

82 FOWNES BROTHERS, 41 Cheapside—Manufacturers.

Ladies' gloves, manufactured from kid-skins, produced in Ireland and dressed in England.

Gloves, manufactured from French-dressed kid-skins. Taffety silk, union silk, velvet, and Lisle thread gloves; beaver, cashmere, goat, and vicuna wool gloves.

Kid-glove in its various stages of manufacture.

83 MACDOUGALL, DONALD, Inverness, Scotland—Manufacturer.

Short pieces of loom-wove tweeds, adapted for deer-stalking and grouse shooting, by their peculiar colours, the natural hues of the rocks and muirs, the haunts of deer and grouse; also for fishing.

A piece of loom-made tweed, from Shetland wool, soft and elastic.

Fine loom-made tartans, for dresses, showing the correct sets of clan patterns. Loom-made plaids.

Highland carpets, called "The Royal" (new design), made from first-class Sutherland Cheviot wool. Pieces of home-manufactured tweed, one made at Tongue, in Sutherland, dyed from heather and crotal (a lichen), the colours rare; the other made at Skye.

Piece of home-manufactured tweed, made at Ord, in Ross-shire, natural colours of deer-wool, brown and white; and a piece made at Avoch in Ross-shire.

Pieces of home-spun tartans, from Perthshire.

Plaid manufactured at St. Kilda, and a small sample of tweed; exhibited as curiosities, illustrating the industry of the natives of the most remote of the British islands; the yarn is spun by the distaff, and woven in a native-made loom.

Home-made plaids: specimens of home-knitted stockings and socks, dyed from heather, soot, crotal (a lichen), alder-bark, &c.

Home-made gloves, some of wool, and one pair of the wool of the white mountain hare; exhibited because the material is unusual.

Knitted shawl made in the island of Lewis, and another from Sutherland. A woman's shoulder plaid manufactured in the year 1768, showing the state of industry in Lewis eighty-three years ago. Towel made from flax, grown, spun, and woven in that island.

Sample piece of linsey-woolsey, made of Cheviot wool and bog cotton (*Eriophorum vaginatum*), the latter now first used in manufactures.

Sample of tweed made of vicuna wool, and under-dresses of the same material.

Home-made plaid blankets, from Ross-shire and Sutherland.

Highland brooches, made of carved bog-oak, deer's teeth, and Cairngorms.

Highland ornaments: a purse, horn, skeindhu, and drinking cup.

Small quantities of yarn, showing the following native dyes, from crotal (a lichen), colours, drab and brown heather, yellow, and a specimen of green; cudbear, (a lichen), colours, drab and brown, and a lighter shade alder-bark and water-lily root (*Nymphaea alba* or *Nuphar lutea*) black; soot, dark brown; rhubarb, buff.

Specimens of rock crystal, or "Cairngorm," from the mountain of that name in Inverness-shire. Native dye-stuffs; water-lily root, alder-bark, heather, cudbear plant (a lichen), and crotal (a lichen). Sample of bog-cotton (*Eriophorum vaginatum*).

[The white mountain hare, mentioned by the exhibitor, is the *Lepus variabilis*, a distinct species from the common hare, and an inhabitant of the mountainous districts only in Britain, though in Ireland a variety of it takes the place of the common hare. It is identical with the hare of Norway.

The cotton-grasses, or bog-cotton, are species of sedge of the genus *Eriophorum*. The *E. vaginatum*, single-headed cotton-grass, and the *E. polystachion*, a many-headed species, are the most common, and are abundant in all the bogs throughout the British Islands. There are other kinds also, but rarer. Their spikes are invested with long cottony hairs, beautifully white. Many attempts have been made to employ this substance in manufactures, for which it seems well adapted, but (until that now exhibited) without success. The material is very abundant, especially in Scotland and Ireland.—E. F.]

84 HOLMES, JAMES, & Co., 171 Regent Street—Inventors and Manufacturers.

Cashmere quilted full-dress or opera cloak, composed of the finest white wool worked into small diamond-shaped cells, with 1,200 gold pendants of various sizes, one being placed at the point of each alternate cell. The inside or lining is of white satin, quilted, with emblematical wreath of the United Kingdom. In the centre is a figure of Britannia, quilted, with wreath around. The hood is in keeping with the cloak, quilted, with device in gold work.

Registered shawl cloak, woven in one piece, with a hood of same material, designed and manufactured by the exhibitors.

Patterns of cameleon cloth, a new material, with two distinct colours.

Cloak, made of the cameleon cloth; registered by the exhibitors.

85 WIGHAM & Co., Edinburgh—Manufacturers.

Tartan plaids, or long shawls of various Highland clans, combined and separate.

86 SOLOMON, SARAH, 52 York Road, Lambeth—Designer and Manufacturer.

A lady's English costume ball-dress, embroidered with gold and silk. The costume fashioned, made up, and embroidered by the exhibitor alone.

87 GWATKIN, EMILY & ELIZA, 37 Westminster Bridge Road—Designers.

Bonnet made from cotton, worked into form by crochet, and brought into finished shape by registered method.

Bonnet made of satin, of new design and workmanship; formed from 300 separate pieces.

88 OLIVER, B. S., Nottingham—Manufacturer and Importer.

Varieties of pasteboard boxes for containing lace, hosiery, gloves, and fancy articles.

89 MILES, SIMEON, 89 Bunhill Row—Producer.

Variety of Berlin wool work.

90 SAXTON, ALFRED, Nottingham—Manufacturer.

Ladies' mitts, cuffs, and gloves, embroidered and made of silk; neck-ties and silk shawls, Jacquard patterns, &c.

"Antimacassar" toilet covers and tray-covers, centred pattern, Jacquard.

91 SHAW, JOHN, Radford, near Nottingham—Manufacturer.

Berlin wool vest, made from the stocking frame, with the Jacquard.

Piece for window curtains from the stocking frame, and "antimacassar" from the stocking frame (cotton).

- 92 THURMAN, PIGGOTT, & Co., *Friar Lane, Nottingham*—Manufacturers and Inventors.
Hosiery goods, manufactured under Thurman's patent, from silk.
- 93 GALLOWAY & SONS, *Nottingham*—Manufacturers.
A variety of silk gloves.
- 94 FURLEY, JOHN, *Nottingham*—Manufacturer.
Ladies' and gentlemen's merino vests, in wool and mixed materials.
- 96 HOLLINS, S., *Nottingham*—Manufacturer.
Lace goods. Machine-made cotton Brussels nets and laces, figured by the needle. Various hosiery goods.
- 97 MUSSON, R. & J., *Nottingham*—Manufacturers.
Silk gloves. Lisle thread, spun silk, plated silk, and fleecy lined gloves.
Patent Brayama gloves; a new material, fleecy inside. Embroidered gloves.
- 98 CARVER & GILBERT, *Nottingham*—Proprietors and Manufacturers.
Cotton, Novi silk, spun silk, merino and Cashmere gentlemen's and ladies' vests.
- 99 HURST & SONS, *Nottingham*—Manufacturers.
Brown and white, plain, open-work, and embossed cotton hose and half-hose; cotton and spun silk drawers and vests.
- 100 ALLEN & SOLLY, *Nottingham and London*—Manufacturers.
Samples of hosiery; with samples intended to show the progress of cotton-spinning for the hosiery trade from an early period to the present time. Specimens of cotton, lisle thread, linen thread, spun-silk, and merino hosiery.
- 101 MORLEY, J. & R., *London and Nottingham*—Manufacturers.
Specimens of white cotton stockings for ladies.
White Lisle thread stockings.
Balbriggan stockings.
Silk stockings with cotton tops.
Silk stockings.
Silk stockings, lace open work.
Balbriggan stockings, lace open work.
Children's spun silk Braganza gloves, fleeced.
Children's coloured silk gloves.
Fancy coloured silk gloves for ladies.
Children's white cotton stockings.
Children's brown cotton Derby ribbed socks.
Children's white Lisle thread socks.
Children's white Lisle thread socks, lace open work.
Children's silk socks, lace open work.
Cotton half-hose for gentlemen.
Balbriggan half-hose.
Balbriggan half-hose, Derby-ribbed.
Cotton half-hose, with spun silk double feet (curious).
Cotton half-hose, with fancy merino feet.
Derby-ribbed cotton half-hose, with fancy merino feet.
Cotton half-hose, with real beaver feet (superior).
Derby-ribbed cotton half-hose, with real beaver feet (superior).
Fancy merino half-hose.
Fancy merino Derby-ribbed half-hose.
Spun silk shirts for gentlemen.
Silk shirts.
Spun silk Braganza shirts, fleeced.
- 102 TRESS & Co., *Blackfriars Road*—Manufacturers.
Ladies' habit hat "Queen's," original design, composed of silk plush and finished with satin, under side trimmed with plush, band and plumes, on fine cotton body, ventilated, light and elastic.
Ladies' habit hat "Princess," original design.
- Ladies' habit hat "Duchess," original design, trimmed with a fine brush feather.
Ladies' habit hat "Princess," novel colour, composed of silver-grey silk plush, finished with satin under side, and trimmed.
New design, gentlemen's drab hats composed of fine woollen cover, on cotton body, very light and elastic, and well ventilated, suitable for hot weather and climates, being a "non-conductor" of heat.
Gentleman's hat, new design, composed of silk plush, improved finish, cloth underside, very light and elastic. The same, with original design.
- 103 BERNI & MELLIARD, 56 *Great Guildford Street, Southwark, and 203 Strand*—Manufacturers.
Military and court hats, new styles. Napless beavers.
Ladies' black napless beaver riding hats, exhibited for their texture, and style.
Silk plush hats, with elastic felt and other bodies.
Folding opera hat, made of velvet.
- 104 EVELEIGH & SON, *Manchester*—Manufacturers.
Various kinds of hats, in silk, felt, and cork.
- 105 SIMMONDS & WOODMAN, *Oldham*—Manufacturers.
Beaver hatting materials, from the skin to the hat, complete.
Gentleman's black beaver, drab, and napless hats, trimmed complete.
Black silk hats, and patent reflectors.
Ladies' white and drab beaver, napless, full trimmed.
Child's white and drab beaver, napless.
- 106 STANDISH, ANNE, *Kidderminster*—Lace-worker and Producer.
Court dress of needle-work.
- 107 HILL, LUKE MARSHALL, *Whitby*—Inventor.
"Unique habit," cut out in one piece, and having no seam on the top of the shoulder, the outside of the arm, or down the middle of the back.
- 1 8 WATTS, WILLIAM, *Banbury*—Inventor.
Complete coat, trousers, and gaiters, in one piece, without any seam.
- 109 WALSH & Co., *Bristol*—Producers.
Embroidered over-coat.
- 110 GOULDING, JOHNSON, *Beverley*—Inventor and Manufacturer.
Novel full-dress coat, the body of which is cut out of one piece of cloth, with two seams instead of nine.
- 110A LEE, J.—Producer.
Quilted coat, and instrument for quilting.
- 111 HARRIS & TOMKINS, *Abingdon, Berks*—Manufacturers.
Two worked frocks for agricultural labourers, in white duck; the designs by Thomas Watson. One worked by Hannah Stimpson, a cottager of Radley, Berks; on the sides are the national emblems, the royal crown, doves bearing olive branches, interworked with mottoes—"Vivat Regina," and "Peace with all the world." The collar and shoulder-straps bear appropriate devices; the wristbands display the royal crown, enclosed in a scroll, interworked with the motto, "Long live our gracious Queen." At the end are the Prince of Wales's feathers. The bosom and sleeves are fancifully gauged, and display the crown, rose, shamrock, thistle, sprigs, &c.
The other worked by Esther Stimpson, sister of the preceding. The side-work represents Industry, with Fame crowning her with a wreath; above are a wheat sheaf, flowers, &c. The collars contain agricultural implements, encircled with mottoes, "God speed the plough," and

“Success to agriculture.” The shoulder-straps show a hive of bees, &c.; the wristbands, oak boughs and acorns; the bosom and sleeves are gauged in the same style.

112 CAULCHER, J. D., *Anstruther Villa, Boundary Road, St. John's Wood*—Inventor.

Life-preserving elastic cork jacket, capable of being worn unobserved under a coat or a mantle; and, in consequence of its pliability, can be worn comfortably whilst rowing a boat, &c.—Registered.

113 DOUDNEY, E., 17 *Old Bond St.*, 25 *Burlington Arcade*, and 49 *Lombard Street*—Inventor and Maker.

The waterproof Irish poplin registered cloak. The application of the waterproofing process to Irish poplin protects it from injury by wet, and renders it suitable for ladies' dresses, for yachting, and exposure to wet and damp.

114 LEWIS & SON, 1 *Quiet Street*, and 1 *John Street*, *Bath*—Designers.

Over-coat, of novel design and light texture.

115 DINGLEY, W. & S., *Sherborne, Dorset*—Inventors.

A new overcoat, combining a paletot, trousers, and railway wrapper, which may be used or not at pleasure, for walking, driving, or riding; registered as “Dingley's Protector.”

115A CROSS, C., & Co., *Corporation Street, Manchester*—Manufacturers.

Articles of clothing made by power-loom.

116 FRY, JOHN LIDDON, *Honiton, Devon*—Inventor and Manufacturer.

Dress coat: the body is cut in one piece, without back, body, under-arm or lappel seams. Round jacket, similarly cut.

Registered measure, called by the inventor the “cardinal point measure and rule,” for taking the dimensions of the human figure, and adapted to every variety of shape.

117 GRIFFIN, BENJAMIN, *High Street, Leominster, Herefordshire*—Inventor.

Four arithmetical, geometrical, and self-variable systems of cutting in one book. These systems contain a number of mathematical figures or diagrams, to form certain shapes, for making coats, vests, trousers, and other garments.

118 MCGEE, J. G., & Co., *Belfast*—Manufacturers.

Embroidered vests: the designs are by pupils of the Belfast Government School of Design; and the embroidery the work of poor girls who have been only nine months under the tuition of the exhibitors.

119 SMITH, CHARLOTTE, *Bedford*—Inventress.

Patent symmetrical corsets, enabling the wearer to regulate the pressure of the stay (as may be required) in a simple manner.

Patent “soccopedes elasticus,” or elastic silk boots, manufactured by Mr. Longdon, of Derby. The top part is woven all in one piece, and being composed of an extensible material, with elastic ankle-band, it adapts itself to the shape of the leg and foot, without side-springs or lacings, and gives support to the ankle.

120 GALLAWAY, T., 43 *Albion Street, Leeds*—Manufacturer.

Three woven corsets.

121 ODDY, S., *Armley, Leeds*—Manufacturer.

Coloured fine wool shawls, with embroidered corners, and other ornaments.

122 TINSLEY, J., & Co., *Leeds*—Manufacturers.

Improved woven corsets for ladies, without a seam; made of prepared cotton yarn, free from any dressing composition; exhibited for shape, workmanship, and utility.

123 MIDDLEBROOK, T., *Leeds*—Manufacturer.

Military officer's cap and cover. Black silk velvet smoking or carriage cap.

124 HALEY, WILLIAM, *Leeds*—Inventor and Manufacturer.

Protection travelling cap, peculiarly adapted for cold climates.

125 MOLLADY, JOHN, & SONS, *Warwick*—Manufacturers.

Specimens showing the manufacture of a stuff hat, from the raw material through seven different stages to the complete hat.

New design of a lady's embossed felt bonnet, trimmed. Stuffrustics, novel styles; sombrero hats, varied colours; new designs in children's fancy hats, and coloured felt bonnets.

Silk hats, ventilating, cork, and gossamer hats, exhibited for lightness and elasticity.

Light zephyr hat, weight under three ounces. The lightness is attained by the introduction of a new combination of material in the body.

Welsh lady's hat; “Cardiganshire,” of improved design.

[By the technical term “stuff hats,” is meant the best description of hats made in imitation of beaver. In these hats the fur of various animals is employed, and is applied to a foundation which is rendered waterproof by the application of spirit varnishes. The annual value of stuff hats produced in this country is taken to be about 800,000l.]

126 CARRINGTON, SAMUEL & THOMAS, *Stockport*—Manufacturers.

Pearl, drab, and silvery-cloth and felt hats, raised nap. Brown nutria, natural colour, felt hat, made of beaver and other furs.

Fawn or buff, and other kinds of felt hats, light and elastic.

Silvery grey and black hats.

Brown felt fishing hat; waterproof, soft, and flexible.

Felt rustics, of various qualities.

Ladies' flexible felt riding hats.

Children's felt hats, natural colours.

126A PEARSON, JOHN, 7 *Gorse Brow, Stockport*—Manufacturer.

White beaver bonnet.

127 TAYLOR & Co., *St. James Street, Rochdale*—Manufacturers.

Specimens of silk plush for hats.

127A LEES, A., *Manchester*—Manufacturer.

Felt, velvet, and alpaca hats. Cloth caps.

128 McRAE, JOHN JAMIESON, *Newark, Notts*—Designer and Inventor.

A triple stay, adapted for use in portions of male attire which require to be made strong.

A waistcoat which can be lengthened or shortened at pleasure, with the triple stay attached, adapted for summer wear.

Finest alpaca summer coat, with the triple stay attached; with four pockets, weight 6 oz., and can be worn either side.

A waistcoat of improved form and arrangement, made to supersede the use of braces across the shoulders. The fabric was manufactured by Messrs. Aaron Peace and Co., Clayton West, near Huddersfield.

An improved self-sustaining top to drawers, intended to supersede the use of belts.

129 JOHNSTON, J., *Stirling*—Manufacturer.
Hose, showing improvements at different periods.

130 PATERSON, J., *Dumfries*—Designer and
Manufacturer.

A web of patterns, a vest, several vest pieces, and half-hose. All made on the common stocking frame, and exhibited for warmth, durability, and design.

131 DARLING, G., 35 *George Street, Perth*—Inventor
and Manufacturer.

Gentleman's hat, thoroughly waterproof and ventilated; the mode of ventilation being quite novel. Highland bonnets.

132 GIBSON, Capt., *Perthshire*—Producer.
Shepherd's plaid of natural colour.

133 LAING, JOHN, *Hawick, Scotland*—Manufacturer.

Patterns of hosiery and under-clothing knitted upon the stocking-frame, made from Australian wools.

134 HADDEN, ALEXANDER, & SONS, *Aberdeen*—
Manufacturers.

Knitting worsteds, spun from British wools. Card containing 1,000 colours, dyed on worsteds manufactured from British and Saxony wools. Knitted worsted shawl and hosiery.

135 SMART, RICHARD, 10 *Upper Eaton Street, Grosvenor Place*—Inventor.

The "Subclavian sector"—so called by its measures being taken from the armpit; an apparatus for obtaining more correct measurement of the human body.

135A CATTANACH, CHARLES, *Aberdeen*—Inventor.

Apparatus for measuring the human figure, and for transferring the measure to cloth so as to produce an exact fit of garment.

136 ROY, JESSIE, *Ferryhill, Aberdeen*—Inventor.

A landscape, knitted in Berlin worsteds. A pair of stockings, with Cashmere pattern.

137 WOOD, JANET, *Stonehaven, Scotland*—Manufacturer.
Pair of fancy knitted worsted gloves.

138 WEBB, Capt. THEODOSIUS, R.E., *Woolwich*—
Producer.

Specimen of knitting from the Shetland Isles, showing 26 patterns used by the inhabitants. The art of dyeing wool is considered to have been taught them by Spaniards wrecked there, after the dispersion of the "Invincible Armada."

139 WHITEHEAD, WILLIAM, & SON, 41 *South Bridge Street, Edinburgh*—Manufacturers.

Tartan hose, clan Breadalbane (or Campbell), made on a No. 32 gaze-frame; each pair containing 1,300 diamonds (or squares) made from fine worsted. Clan MacDuff, containing 540 diamonds. Clan Royal Stuart silk tartan, made on a No. 42 gaze 3-needle frame.

140 KAYE, FINDLAY, & Co. *Langholm, and Glasgow*—
Manufacturers.

Cheviot wool hose: six pairs of women's two-thread grey, and six pairs white; twelve pairs children's white, and six pairs men's grey; twelve pairs men's half hose.

Six pairs women's hose, with ribbed tops, Saxony wool; twelve pairs men's half hose grey Shetland wool;

twelve pairs men's four-thread brown half hose; twelve pairs men's, vicuna wool.

Six women's gauze vests, six children's gauze vests, and six women's full dresses, all Cheviot wool.

Six men's gauze pantaloons, and six men's three-thread pantaloons, of Cheviot wool. Three men's four-thread Saxony wool pantaloons; six men's two-thread, and one ribbed, Cheviot wool, pantaloons.

Six men's vests, of Cheviot wool, with long sleeves, double-breasted, and shaped shoulder; six of the same, single-breasted. Six pairs of No. two and three-thread white worsted knit hose.

141 SCOTT, PETER, 9 *South Bridge, Edinburgh*—Designer
and Manufacturer.

The V-breasted and swivel-collared shirt.

142 MACKENZIE, WILLIAM BAILLIE, 126 *Prince's Street, Edinburgh*—Proprietor.

Articles knitted by the hand in the Shetland Islands, from the wool of their sheep.

Shawls; handkerchief; child's frock; veils of the natural-coloured wool; white and coloured gloves; ladies' white and coloured mitts; ladies' brown and white stockings, very fine wool; an extremely fine pair of stockings; natural-coloured socks; white knee-caps; brown leggings, natural colour; sleeves; ladies' caps; nightcaps; wigs; comforters, and shirt.

Specimen of Shetland yarn, handspun; and of the Shetland wool, as it is taken from the sheep.

Articles that are knitted in Fair Isle, one of the Shetland Islands.—Fair Isle socks, gloves, vest piece, comforter, and cap.

Shawls and veils, knitted by the hand in Shetland from a thread spun by machinery, composed of wool and silk together.

[Knitting is the chief employment of the female inhabitants of these isles in their own homes. Stockings have been made there from a very ancient period; but the fanciful knitting, comprising shawls, &c., is of recent introduction.]

143 JOHNSTON, JAMES & GEORGE, *Paisley, and 2 Chapter House Court, St. Paul's*.

Buckram and Paris net bonnet tops and crowns, manufactured by steam power.

144 LAUGHLAND, J., *Kilmarnock, Scotland*—
Manufacturer.

Australian sheep's wool.

White, green, blue, and scarlet yarn, and an officer's dress bonnet, showing the process of knitting.

Knitted bonnet; milled bonnet; finished bonnet, as used by the officers of the 42nd, 72nd, 74th, 78th, and 92nd Highland regiments; all from Australian wool.

New regulation forage caps; serjeant's, blue; private's, blue, scarlet, and crimson.

Old regulation forage-caps; serjeant's, blue, with white band; private's, blue, with scarlet band.

Prince Charlie bonnet. Turkish crimson cap or bonnet.

Balmoral bonnet. Glengarry bonnet.

Gentleman's head-dress.

145 RITCHIE, PETER, *Kilmarnock, Scotland*—
Manufacturer.

Regulation military forage caps:—Serjeant's, blue and rifle-green. Serjeant's, 71st Highlanders, Light Infantry. Serjeant's, with plaid border. Officer's, with white band. Scarlet Fez cap. Officer's, light blue cap. Prince Charlie caps, blue and grey. Blue Balmoral cap. Grey Glengarry cap, with plaid border. Caledonian hats, black, grey, and green. Specimens of the military and other caps, "set up."

- 147 KINCAID-LENNOX, F. M., *Lennox Castle, Lennox-town, & 9 Arlington St., Piccadilly*—Proprietor.
Linen and cotton shirts, made in Glasgow; exhibited to show the quality of plain British needlework.
- 147A RUTTENS, HELENE, 13 *Charles Street, Soho Square*—Inventor.
Fan, travelling, and specimen bonnets, in silk.
- 148 HAYWOOD, MARY, 3 *Dyer's Buildings, City Road*—Designer.
A shawl of white cashmere, worked in braid, ornamented and fringed with peacock's feathers, the eyes of which are disposed so as to resemble gems.
Narrow fringe, made of the same materials.
- 149 JONES, JOHN, 17 *Duke Street, Liverpool*—Inventor.
Registered tailors' symmetrometer. Adapted for cutting coats and waistcoats. The trousers' rule.
- 149A ROBINSON, J.—Inventor.
Measuring apparatus for tailors.
- 150 CLOWES, F., 28 *Ann Street, Birmingham*—Inventor and Manufacturer.
Improved elastic coat. Registered trousers, elastic riding belt, and brace.
- 151 MINIFIE, CHARLES, *Bristol*—Inventor and Manufacturer.
Registered coat sleeve shirt.
- 152 McCLINTOCK, JAMES, & Co., *Barnsley*—Inventors and Manufacturers.
Double silk elastic woven corsets, with the royal arms and national emblems inserted. Woven to fit the body, and recommended for freedom of respiration.
Thread-wove corset, without seam.
- 153 BIRT, HARFORD, *Shepton Mallet, near Wells, Somersetshire*—Inventor.
Transitional coat, adapted for changes of the weather.
A frock coat. An open-breasted vest. A double-breasted vest.
Surtout as an over-coat, with concealed hood for travelling, &c.
- 154 TOLLET, G., *Besley Hall, near Newcastle, Staffordshire*—Manufacturer.
Tippets, cuffs, cloaks, victorines, and muffs, composed of feathers and goose down, and made by the needle and thread.
- 155 HODGSON, T., jun., 39 *Iron Market, Newcastle-under-Lyme*—Designer and Manufacturer.
Elastic corset.
Invisible spinal support.
- 156 CLEMES & SON, *St. Austell*—Manufacturers.
Underground hats for Cornish miners and mine agents, used for protection against falling stones, &c.
- 156A BEAUFORT, Miss, *Cork*—Producer.
Knitted child's pelisse.
- 157 MASON, WILLIAM, *Newcastle-under-Lyme*—Manufacturer.
Velvet-*nap* hats, on an improved body. Waterproof beaver hat.
Waterproof felt hat, adapted to tropical climates.
Silk hat, on a body of cashmere.
Felt hat, designed by Mr. Killingworth Johnson, registered as the "Raphael."
Felt travelling hat, registered as the "Crichton."
- 158 LAURENCE, ELIZABETH, 15 *Montpelier Walk, Cheltenham*—Manufacturer.
White French merino dress for ladies, braided and trimmed with satin. Crimson velvet dress for boys, braided; the design, the rose, shamrock, and thistle.
White satin drawn-bonnet.
- 159 WHITE, E., *Edgar Buildings, Bath*—Manufacturer.
Bassinette, or infant's cradle, completely furnished. Infant's frock and robe.
Lady's chemise and night dress. Gentleman's shirt.
- 160 HATHAWAY, Mrs., *Brompton, near Chatham*—Producer.
A baby's hat knitted in fine white silk.
- 161 FIRMIN & SONS, 153 *Strand and 13 Conduit Street, Bond Street*—Manufacturers.
Specimens of buttons. Stars of the Order of the Garter, the Thistle, and St. Patrick. Swords for officers in the army and navy, &c.
- 162 HURST & REYNOLDS, 100 *New Street, Birmingham*—Manufacturers.
Ladies' stays or corset, to fasten and unfasten instantaneously without lacing.
- 162A BEESTON, J. S., *Swaile's Cottages, Hammersmith*—Producer.
Inflated railway caps.
- 163 FIRKINS, JOS., & Co., *Worcester*—Manufacturers.
Ladies' habits. Black and coloured French kid gloves. Gentlemen's black and coloured calf gloves. Cape-goat gloves.
Beaver, Norway doe, Buck, Lisle, Berlin, and cloth gloves; improved thumbs and new cut, &c. Provisionally registered.
- 164 REDGRAVE, JOHN, *Worcester*—Manufacturer.
Men's coloured, black, and tan Cape gloves; piqué. Ladies' white Cape gauntlets.
Habits—coloured, maze, Napoleon blue, yellow, light blue, and drab. Made from lamb-skins and Cape sheep.
- 165 RIDLEY, J., *St. Paul's Churchyard*—Manufacturer.
Ladies' boots and shoes.
- 166 THE LOCAL COMMITTEE OF NEWBURY, *Berkshire*—by Sir John Throckmorton.
An oil painting: Sir John Throckmorton presenting two South Down wether sheep to Mr. John Coxeter of Greenham, Newbury, Berks, who engaged, on the day they were presented, to make their wool into a piece of cloth, that should be made into a coat by 9 o'clock of the same evening.
The sheep were immediately shorn, and the wool sorted and spun. The yarn was spooled, warped, loomed, and woven. The cloth was burred, milled, rowed, dyed, dried, sheared, and pressed. The cloth having been thus made from the fleece in 11 hours, was put into the hands of the tailor at 4 o'clock in the afternoon, who completed the coat at 20 minutes past 6, having been only 2 hours and 20 minutes in making it: Mr. Coxeter then presented the coat to Sir John Throckmorton, who appeared with it on, before a large assembly of spectators.
- 167 NORMAN, S. W., 4 *Oakley Street, Lambeth*—Inventor and Manufacturer.
Ladies' cork and leather light waterproof boots. Ladies' shoes.
- 168 LONGDON, R., and Sons, *Derby*—Manufacturers.
Patent frame-work gloves, without any seam on one side.
Smith's patent "Soccopedes Elasticus." This boot requires no lacing.

- 168A HELPS, Miss, *London Road, Liverpool*—Producer.
Gutta percha articles.
- 169 POORE, J. B., 9 *Princes Court, Banner St., St. Luke's*—
Designer and Manufacturer.
A lady's victorine, with cuffs, made of feathers, ornamentally arranged. Original design and manufacture.
- 170 BARFORD, FRED., *Market Place, St. Albans, Hertfordshire*—Inventor.
Registered "Brazilian palm-leaf Wellington" hats. This hat has a feather edge, interwoven with the palm leaf. It is also interwoven with various-coloured straws, forming a brim and band, and dispensing with any ribbon or other ornament.
The "Princess Alice" hat for young ladies, formed only of the palm-leaf, with a fancy band, brim and feather edge.
The "Chinese" hat, with a fancy band, brim and feather edge, also made of the palm-leaf.
Three willow hats of the English willow-tree.
[The Brazilian, or palm-leaf, is of great size and substance, and the tree is indigenous to South America. After its importation, it undergoes various processes, as bleaching, &c., for the improvement of its colour, and to render it soft, pliable, and available for working; it then becomes light, durable, and useful. The above hat is accompanied by a portion of the palm-leaf.]
- 171 ASHTON, A., *George Street, Portman Square*—
Inventor.
Registered bonnet and case.
- 172 ELLIOTT, W., *Dunstable, Beds*—Manufacturer.
Straw hats, bonnets, plait, and fancy straw articles.
- 172A COOPER, J. J. & G., *Dunstable, Bedfordshire*—
Manufacturers.
Straw hats and bonnets. Plait, and fancy straw articles.
- 173 MUIRS, CONNELL, & BRODIE, *Luton, Bedfordshire*—
Manufacturers.
Specimens of plaits and bonnets manufactured from wheat straw grown in Bedfordshire.
Wheat straw as taken from the fields, prepared for making whole straw plait; prepared for splitting; split ready for plaiting; whole straw plait, whipcord, and improved whipcord plait.
Luton, Devon, China, Coburg, and pearl; Coburg, Bedford, Indiana, Brussels Coburg, tulip, and fancy-tulip plait.
Luton patent improved whipcord, patent whipcord, Indiana, satin, porcupine, diamond, split Coburg, and China pearl rice, Bedford plait.
Ladies' bonnets, including whole-straw, whole-whipcord, improved whipcord, Luton, fine patent, fine split, tulip, fancy tulip, Indiana, Brussels, Coburg, and fancy split, improved and patent rice, whipcord, diamond, China pearl, Bedford, split Coburg, fancy split Coburg, and fancy coloured.
Maid's whole whipcord, and girl's fancy Albert, and child's patent bonnets.
Boys' fancy Coburg, and improved hats.
- 174 LINKLATER, —, *Shetland Isles*—Producer.
Specimens of knitting peculiar to the Shetland Isles.
- 175 KEARSE, THOMAS, 40 *George Street, Limerick, Ireland*—Designer.
Winter and summer overcoat combined, composed of Irish frieze and tabinet, and capable of various transformations.
Waistcoat of Irish frieze and tabinet, of similar construction. Trousers of Irish frieze.
Infantry coat and cavalry waistcoat, lined with Irish tabinet.
- 176 FARRANGE, Miss, *Wicklow, Ireland*—Producer.
Knitted stockings.
- 177 VINCENT, R., *Glastonbury*—Manufacturer.
Suit of leather clothes, made to imitate superfine black cloth.
- 177A STEWART, JANE, *Templetrine Glebe, Bandon, Ireland*—Proprietor.
Articles made at the Templetrine industrial school by the poorest class of the peasantry, viz.: coarse ribbed gentlemen's white socks. Knitted long and short black silk mittens. Children's knitted silk socks. Fine white knitted ladies' stockings and mittens.
- 178 KELLY, J. & Co., 98 *High Street, Kilkenny, Ireland*—Manufacturers.
Buckskin hunting breeches; buckskin raw material, &c.
- 179 NAIRN, THOMAS GRAHAM, *Limerick*—
Manufacturer.
Irish uniform frock-coat, for the Royal Horse Artillery.
Irish frieze national cape, flowered at bottom; with the frieze cut, and sewed on; without seams, and cut out of the piece.
Irish frieze paletot-jacket, for shooting, fishing, and walking.
- 180 WOODHOUSE, JOHN, 39 *Lover Ormond Quay, Dublin*—
Manufacturer.
Gilt and plated buttons. German silver letters and figures. Brass mountings for military accoutrements.
- 181 PEASANTS, FEMALE, of *Wexford, Ireland*—Producers.
Samples of Traneen grass, plaited in the Leghorn and Tuscan style.
- 182 MAHER, LOUISA, *Ballinkee, Enniscorthy, Ireland*—
Proprietor.
Samples of *Cynosurus cristatus* grass, or Traneen; and of rye straw. Plait of these articles.
Articles made of Traneen plait, viz., hat, bonnets, flower-stands, and basket; and of rye straw plait, viz., hat and basket.
Samples of black, white, and coloured floor-matting.
Twenty-four varieties of plait for bonnets made of Traneen.
[The *Cynosurus*, called in English crested dog's-tail grass, forms a large part of all good pastures, lawns, &c., in England and Wales.—J. L.]
- 183 WILSON & SON, *Drogheda Street, Dublin*—
Manufacturers.
Balbriggan hosiery.
- 184 DICKS, W., *Yeovil*—Manufacturer.
Lamb-skin gloves.
- 185 ENSOR, THOMAS, *Milborne Port, near Sherborne*—
Manufacturer.
Fur and kid gloves. Gloves lined with silk plush, wools, lamb-skin, &c. Goat, calf, lamb, sheep, deer, and fawn gloves.
Patent glove, with a small purse inserted in the palm of the left hand.
- 186 WHITBY, E., *Yeovil*—Manufacturer.
Skins in various stages of manufacture, and gloves.
- 187 PITMAN, J., *Milborne Port*—Manufacturer.
An assortment of gloves.
- 188 RAWLINGS, JOSEPH, B., *Abbey Silk Mills, Sherborne, Dorset*—Manufacturer.
Gloving and sewing silks, for tambour, of various shades. Scarf; half-twist cloth, &c., of superior quality.

- 189 MONEY, ELIZABETH, *Woodstock, Oxon*—
Manufacturer.
Lamb-skin, as received from the leather-dresser.
Drawn, round, and seam gloves, manufactured from
lamb-skins.
English fawn-skin riding gloves for ladies.
- 190 CORRY, JOHN & JAMES, *Queen Camel, near Yeovil,
Somerset*—Manufacturers.
Coloured and white lamb-skins.
Ladies' and gentlemen's coloured and black leather
grain gloves.
- 191 MATHIESON, Lady, *Lewis Castle, Stornoway*—
Producer.
Embroidered muslin skirt, worked by the children at
the school in the Hebrides.
Two pair of hand-screens, made from feathers of wild
birds in the outer Hebrides, by Miss Cameron of Storno-
way.
- 192 THOMPSON, JOHN, & Co., *Kendal*—Manufacturers.
Hand-knit Guernsey frocks (or woollen shirts). Scar-
let and fawn caps; single scarlet; fancy striped; and
striped Kilmarnock caps. Fancy Glengarry and plaid
caps (or bonnets). Striped fleecy and milled mitts.
Wad-milled overalls (or boot-hose).
- 193 FRY, JAMES, *Godalming, Surrey*—Manufacturer.
Fine Lisle-thread hose embroidered. Four-thread hose,
plain.
Fleecy breast-plates. Segovia shirts and pantaloons.
Merino shirts and vests.
Cotton pantaloons, drawers, and shirts.
The three preceding articles are all in different qualities.
- 194 HOLLAND, THOMAS, & Co., *Langham Factory,
Godalming*—Inventors, Manufacturers, and Propri-
etors.
Ladies' dresses; waistcoats, petticoats, drawers, &c.
Men's shirts, trousers, drawers, hose, &c., manufactured
of a fleecy wool, different from any hitherto adopted for
under clothing.
Similar articles in "Segovia;" likewise prepared from a
peculiar wool; also, in "double Segovia," and in silk and
wool.
Men's trousers, shirts, and hose, in cotton. Cloth for
outside wear.
Over-coat, exhibited for lightness and warmth.
Elastic cloth, calculated for breeches and trousers, used
in riding.
Registered waistcoat, with elastic ribbed back.
Registered shirts, with elastic backs, and smooth fronts;
ribbed or plain, made from cotton, silk thread, &c.
- 195 WARD, STURT, SHARP, & WARD, *Belper, Derbyshire,
and 89 Wood Street, Cheapside*—Manufacturers.
Specimens of hosiery and glove manufactures, viz.:—
Hose, half-hose, vests, and drawers, in all qualities
from 24 guage to 70 guage, manufactured from cotton,
Lisle thread, merino, cashmere, silk, and spun silk,
amongst which are cotton and Lisle-thread hose made on
a 70-guage frame.
Gloves, mitts, cuffs, sleeves, and caps made from the
same materials.
[By the number of gauge is meant the quantity of loops
within a given space, and hence when these are increased
within that space, the quality of the fabric is increased in
delicacy and value.
The invention of the stocking frame is generally ascribed
to William Lee, an expelled Cambridge student, who,
watching the fingers of his wife, as she toiled for their
mutual support by knitting stockings, devised this
machine. By Elizabeth and James I., Lee was denied
that protection and encouragement due to inventors; he,

however, succeeded in receiving, at the hands of Sully, the
minister of the French King Henry, an acknowledgment
which was denied by his own countrymen. Lee died in
France, and one of his apprentices brought the manufac-
ture back into England, where it has been finally estab-
lished and successfully carried out, Nottingham and
Leicester being its grand centres.]

- 196 CARTWRIGHT & WARNERS, *Loughborough, Leicester*
—Spinners and Manufacturers.
Patent Angola and merino yarns, of various qualities.
Patent Angola and merino hose, half-hose, and socks
(white and coloured).
Shirts, drawers, and ladies' vests and dresses.
Cotton hose and half-hose, with patent Angola ankles
and feet.
- 197 TAYLOR & BEALES, *Leicester*—Manufacturers.
Worsted, woollen, and cotton hosiery of all kinds.
- 198 HARRIS, RICHARD, & SONS, *Leicester*—
Manufacturers.
Lisle, Berlin, military, Cashmere, pique cloth, knitted,
and lined gloves. Tricot piece goods. Cuffs. Mitts.
Ruffles. Muffatees. Socks and bootees. Gaiters and
bootakins.
Caps, hoods, hats, and bonnets. Mantillas and muffs.
Neck-ties, scarfs, and boas. Comforters.
Sailors' and fancy caps. Guernsey, worsted, and lambs-
wool, fancy frocks and shirts. Worsted vests. Lambs-
wool pantaloons. Fancy cotton shirts.
Antimacassars. Netted handkerchiefs and shawls.
Woven shawls.
Children's dresses. Polkas and jackets.
- 199 HUDSON, JAMES, *Leicester*—Manufacturer.
Lambs-wool, Cheviot, Cashmere, Saxony, Victoria, and
worsted hose. Frame-knitted cotton and worsted hose.
A variety of half-hose.
- 200 BAINES, JOHN, *Bowling Green Street, Leicester*—
Manufacturer.
Wool, worsted, and Cashmere hose and half-hose.
- 201 BILLSON & HAMES, *Leicester*—Manufacturers.
Children's socks and three-quarter hose; worsted socks,
and a variety of cotton, worsted, Cashmere, and merino
hose.
- 202 ANGRAVE BROTHERS, *Leicester*—Manufacturers.
Lambs-wool hose, half-hose, shirts, and pantaloons,
various qualities. Royal ribbed and Cashmere shirts and
pantaloons.
Ladies' woollen vests and dresses.
- 203 WARD, WILLIAM, & SONS, *Leicester*—Manufacturers.
Patent fancy cravats, boas, and pelerines without seam.
Gentlemen's alpaca coats and capes. Ladies' polka coats.
Fancy boots and gaiters. Worsted and cotton hose.
Wool frocks.
- 204 BEALE & LATCHMORE, *5 Belvoir Street, Leicester*—
Manufacturers.
Lambs-wool shirts, pantaloons, drawers, vests, and
ladies' dresses. White worsted ladies' dresses; and men's
shirts and pantaloons, and vests. Royal ribbed shirts
and pantaloons. White Guernsey shirts; Canadian shirts,
and pantaloons; coloured shirts, lambs-wool and Cash-
mere hose and half-hose.
- 205 BIGGS & SONS, *Leicester*—Manufacturers.
Men's worsted, lambs-wool, royal ribbed, and cash-
mere shirts and drawers.
Guernsey and Jersey frocks, white and fancy.
Women's worsted, lambs-wool, Cashmere, and royal
ribbed shirts and drawers.

Men's Scotch lambs-wool shirts and drawers, and blue, red, and tri-coloured striped shirts.

Men's worsted, Cashmere, and lambs-wool half hose.

Children's and women's fancy polka-coats.

Men's, women's, and children's Lisle thread, silk mixed, Cashmere, and mixed cashmere gloves.

Patterns of worsted, cotton, Lisle thread, and Berlin pieces.

Union cord and stocking net pieces.

206 WHEELER, THOMAS, & Co., *Abbey Mills, Leicester*—Manufacturers.

Elastic woven fabrics, for garters, glove tops, &c. Elastic braids (under patent of Christopher Nickels, of 13 Goldsmith Street, London) for gloves, wristlets, &c., and other purposes. Non-elastic webs for braces and belts.

Crape and cloth, made, under Nickels' patent, on twist lace machine.

Pile fabric, made on warp machine.

Plush mantillas, from the patent and other fabrics.

Polka jackets, muffs, &c.

207 BIDDLE, JOHN, *Leicester*—Manufacturer.

Cloth of hares' fur and wool uncleaned, made on the stocking-frame; of hares' fur and Saxony wool, with spun-silk warp; of wool from the Cashmere goat; of vicuna wool, from the west coast of South America; of the beaver; and of Saxony wool.

Gloves of hares' fur cloth and Cashmere goats-wool cloth; vicuna and Saxony.

Gloves of Lisle thread-web, made on the warp-machine from No. 300 thread.

Travelling rug, made of the coarsest portions of the vicuna fleece.

208 CORAH, NATHANIEL, & SONS, *Granby Street, Leicester*—Manufacturers.

An extensive assortment of hose, half-hose, and socks, of varied materials, colours, and texture.

Ladies' and gentlemen's wool vests and drawers.

Infants' white and coloured boots.

Ladies' fancy wool cuffs and sleeves. Men's cuffs.

Children's muffs.

Ladies' fancy wool head-dresses. Infants' fancy wool hoods, hats, and bonnets. Ladies' wool paletots.

209 ELLIS, FRED. & JOHN, *Leicester*—Manufacturers.

Silk, Lisle thread, and Cashmere gloves.

211 HARDING, THOMAS, 108 *Regent Street*—Manufacturer.

Vest buttons for gentlemen in lapis lazuli, malachite, coral, onyx, cornelian, bloodstone, aventurine, sardonyx, jasper, &c. Likewise fancy pearl and other dress buttons for ladies.

212 WELCH, MARGETSON, & Co., 17 *Cheapside*—Manufacturers.

Robe de chambre, composed principally of cotton material, and exhibited for quality, durability, and cheapness. Dress stock, on an improved wire foundation, exhibited for ease and durability. Dress full front stocks with embroidered lace fall, new in design.

A selection of "once round" cravats, with embroidered lace ends, new design and pattern. Patent wove linen shirt fronts. The same in piece, and in the grey or unbleached state. Embroidered shirt fronts. An improved travelling or hunting flannel shirt.

The Prince of Wales belts. The Cantab brace. Registered. Most of the preceding manufactured by the exhibitors.

213 STANDON, ANNE, 23 *Wood's Mews, Grosvenor Square*—Manufacturer.

A quilted blue silk bed-cover; exhibited for workmanship.

213A LERWICK LOCAL COMMITTEE, *Scotland*—Producers.

Specimens of knitting from the Shetland Isles.

215 MUIRS, CONNELL, & BRODIE, *Glasgow*—Manufacturers.

Specimens of straw bonnets and plait, manufactured from rye straw grown in the Orkney Islands.

216 DAVIES, RICHARD, *Shaw's Lane, Carmarthen*—Inventor.

A hat made of leather by a peculiar process.

217 WESTMINSTER, the Marchioness of.

Specimens of Shetland hand-knitting.

218 M'CRA, *Western Highlands*.

Specimens of hand-knitting in Berlin wool.



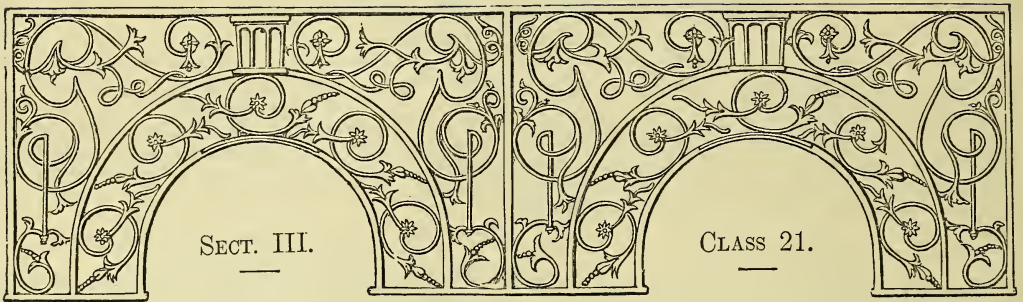

CUTLERY, EDGE AND HAND TOOLS.

INTRODUCTION.

THE present Class in some degree carries the attention again among the implements used in manufactures, and comprehends all those tools not included in Class 6. The tools belonging to the present Class are principally of the smallest description employed in arts requiring delicacy and precision of touch, rather than the exercise of mechanical force. The knives and other sharp instruments, coming under the general denomination of Cutlery, are objects of familiar knowledge and employment.

The Class is divisible into two Sub-Classes; the first of these, A., includes Cutlery, such as Knives and Forks, Pen and Pocket Knives, Razors, Scissors, and Shears: of these some are employed for personal, domestic, or commercial purposes—some for use in various trades and handicrafts—and some belong to the class of ornamental rather than useful articles; B. comprehends Files and other small Edge Tools, not included among Manufacturing Tools in Class 6—of these, some are applicable to the purposes of the engineer and smith, others to those of masons, &c. A finer kind is employed by jewellers, lapidaries, watchmakers, and other workers in philosophical instruments or in precious metals; others are used for woodwork by carpenters, cabinet-makers, &c., and others by artists and engravers.

For those articles in this Class which have not been sent from Sheffield, search will be made in the North Gallery. The Sheffield goods, belonging in strict propriety to this Class, are included among hardware in the following Class, and will be found in the Building on the South Side of the Nave, about midway between the Transept and the Western extremity. The manufactures of Sheffield being the most important, it is necessary to defer the notice of them to the succeeding Class, for the reasons just stated. Nevertheless, in the Metropolis itself a very considerable amount of the best descriptions of articles of cutlery are made; but the proportion of Metropolitan goods in this department, is small in comparison with that of Sheffield, in which the manufacture of cutlery holds a position of the greatest extent and importance.

Many of the minute tools employed in the carver's art and in that of engraving are here exhibited. These tools have acquired much celebrity, and are manufactured of a superior description of steel, and with much skill and care. Although presenting no external feature of interest, these minute instruments represent the means by which much of what is artistically beautiful and pleasing to the eye has been produced: the ingenuity which applies itself to the perfection of the most ordinary articles is conspicuously manifested in many of the specimens of cutlery exhibited, employed either for personal or domestic use.—R. E.

**1 WEATHERLY, EDWARD, 3 Belmont Terrace,
Wandsworth Road.**

Tall's saw-set, being a patent for improvements in the apparatus for setting saws.

**2 THORNHILL, WALTER, 144 New Bond Street—
Manufacturer.**

Steel chatelaine, manufactured after the style of the old pierced steel work. Scissors. Bread knives, with carved box and ivory handles.

Model of a pruning instrument, for pruning trees at any height. Model of a flower-gatherer, which cuts off the flower and holds it.

Specimens of cutlery.

**3 BRADFORD, R. & W., 72 Patrick Street, Cork,
Ireland—Manufacturers.**

Razors, with pearl and tortoiseshell handles, gold rivets, labels, and gold plated heads.

Razors, with ivory handles and silver labels.

A knife, with lock-joint, large blade, pen blade, button hook, corkscrew, leather-punch, gunpicker, twee-lancet, and turnscrew.

Large lock-joint knives, with corkscrews.

A knife, with two blades, corkscrew, and leather punch.

Four-bladed knives, with pearl and stag handles.

Three-bladed knives, with pearl and ivory handles.

Two-bladed penknives, with pearl handles.

Pruning knives and corkscrews.

The razors are so constructed that the thickness of the back and the breadth of the blade give the edge the proper angle for shaving with ease. They were carefully hardened, and tempered in a metallic bath, regulated by a thermometer.

**4 BLOFELD, THOMAS GUEST, & Co., 6 Middle Row,
Holborn—Manufacturers.**

Table cutlery made in London.

Emigrants' and travellers' protector, or burglars' intimidator.

Razor strop, with one side only, and having two handles, by which the equality of the surface is preserved. Invented by the exhibitor.

5 KING & PEACH, *Hull*—Manufacturers.
Specimens showing the different stages in the manufacture of a moulding plane.
Moving fillister, with the fence fixed in the usual manner, and with improved fence.
A sash-fillister, for making the rebate in a sash-bar.

6 DEANE, DRAY, & DEANE, *London Bridge, City*—Proprietors.
Set of superior table and dessert cutlery, with steel, French pattern, three-prong forks, with grand and game carvers, and parallel table steel to correspond.

Table and dessert knives, silver ferrules; grand carvers, game carvers, and hexagon table steel; vegetable four-prong fork.

Table and dessert knives, fluted ivory; with grand and game carvers, and knife sharpener.

Table and dessert knives, Waterloo balance, with grand and game carvers.

Mother-of-pearl silver plated dessert knives and forks, fluted handles.

Ivory German frame spear-point bowie-knife; stag German frame clip-point, polished and glazed.

Ladies' superior fine scissors.

7 MORTON, J. & G., 8 *Great Turnstile, Lincoln's Inn Fields*, and 39 *Cheapside*—Manufacturers.
Specimens of London-made table cutlery.

8 WOOD, J., 28 *Spurrier Gate, York*—Manufacturer.
Registered York razor, having a bevil or slope only on one side. Specimens, showing the different stages of manufacture.

9 COWVAN, BERNARD & SAMUEL, 164 *Fenchurch Street*—Inventors.
Canton strop, or Chinese razor-sharpener.

10 SHARPE, J. & R., 5 *Gough Square*—Manufacturers.
Table-knife cutlery, manufactured in London.

11 ADDIS, SAMUEL JOSEPH, 20 *Gravel Lane, Southwark*.
Tools used by carvers.

12 MECHE, JOHN JOSEPH, 4 *Leadenhall Street*—Manufacturer.
Specimens of British cutlery, razors, scissors, pen-knives, and table knives, in cases.
Specimen razor and table knife, made from the finest tempered steel.

Specimen of the rough steel from which they were manufactured; and specimens showing the various stages of the process.

[In the succeeding class will be found various notes giving account of the process of manufacture of cutlery generally. This manufacture is carried on principally at Sheffield; but it is also prosecuted in other towns, as in the Metropolis, though to a very limited extent.]

13 MOSELEY, JOHN, & SON, 17 & 18 *New Street, Covent Garden*—Manufacturers.

Specimens of planes and various other tools, with modern improvements.

Tool chests, containing tools, adapted to the various branches of mechanical skill.

Cutlery, needles, &c.

14 LOY, WILLIAM, 24 *King Street, Whitehall*—Manufacturer.

Club skates with straps. Skates, fitted with cramps and heel fastenings, to secure them to the boot without straps. Ladies' skates, similarly improved.

15 LOY, W. T., jun., 60 *St. Martin's Lane*—Designer and Manufacturer.

Specimens of cutlery. Registered razors fitted with the Tudor guards.

Razors, with carved ivory and chased metal handles in bronze, silver, and electro-gilt.
Carving knives and forks, and other articles of cutlery, of new design.

16 FIELD, E., 17 *Mary Ann Street, St. George's East*—Inventor.

A cabinetmaker's case of tools.

17 WALDRON, WILLIAM, & SONS—*Stowbridge*—Manufacturers.

Scythes, as used in various countries.

Crown chaff-knife. Hay-knives, with side and T handles. Trussing knife. Bramble scythe.

American grass hook; South of England reaping hook; hedge brushing hook; and pea bill hook.

18 BUCK, JOSEPH, 91 *Waterloo Road, Lambeth*—Manufacturer.

Circular and other saws. Variety of turning and other mechanical tools.

19 YEATES, FREDERICK GREEN, 10 *Wincksworth Buildings, City Road*—Inventor and Manufacturer.

Registered lever knives, for opening preserved provisions, fruits, lardine cases, &c. The advantage is in the power of the fulcrum, or leverage.

Registered twine or string boxes. The internal box, containing the ball of string, revolves and draws back the superfluous string, preventing its becoming entangled.

20 BAKER, WILLIAM, 14 *Allen St., Goswell Street*—Manufacturer.

Awls, bodkins, steels, and other implements, for shoe-makers, carpenters, &c.

21 STEWART, CHARLES, & Co., 22 *Charing Cross*—Manufacturers and Patentees.

Patent Plantagenet guard razor. This razor is shown with the guard in the annexed cut.

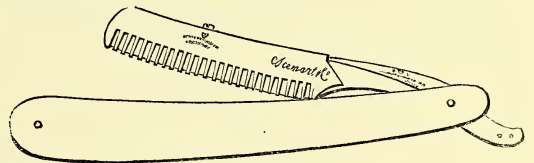

Patent Guard Razor.

Improved razor-strops and paste. The process of cutlery in the manufacture of the razor.

22 TYZACKS, J., 7 *Upper Berners St., Commercial Rd. East*—Inventor.

Double patent British razor.

23 ADDIS, JAMES B., jun., 17 *Charlotte Street, Blackfriars Road*, and 29 *Lucas Street, Deptford*—Inventor.

Carving tools, and a newly-invented set of tools for carving fruit.

24 KNIGHT, GEORGE, & SONS, *Foster Lane*—Manufacturers.

The amateurs' complete lathe cabinet, consisting of a 4½-inch centre lathe on an iron bed, fitted with a slide-rest, and accompanied by a complete arrangement of chucks.

Apparatus and tools requisite for wood, bone, and metal turning, including newly-invented chucks for cutting, filing, and planing.

Mr. Francis' new lathe-rest for the support of delicate work, revolving between the mandril and back centre; also, for boring cylinders, &c.

A dividing engine for the lathe, invented by the Rev. F. Meyler, for the purpose of obtaining a correct division of the circle with great facility.

Improved cleaning, grinding, and polishing machine, for tools, &c., fitted with a series of bobs in bright spindles.

Inside and outside goffering machine, for silks, muslins, straws, &c.

Crimping machine for shawls.

Outside crimping machine, for caps, collars, and dresses.

An assortment of punches for dress-making, flower-making, pattern-making, &c., consisting of straight and pinking; plain and compound scallop; pricking; plain, round, oval, and jagged; leaves, sprigs, veiners, &c.

Joiner's tool-chest, fitted with saws in covered till, planes in rack, and nest of divided drawers, containing a complete assortment of tools.

Household tool-chest, with till and drawers, containing a complete assortment for common purposes.

Amateur's tool-chest, fitted with a tray and divided drawer, and a complete set of tools.

Warehouse chest, fitted with divisions, containing an assortment of tools for packing, opening, and trimming boxes, cases, and casks, and general warehouse work.

Blasting apparatus, for rending timber, stumps of trees, &c.

25 COLGAN & SON, *Limerick*—Manufacturers.

Specimens of cutlery.

26 BRADFORD, SAMUEL, *Baywell Street, Clonmel, Ireland*—Manufacturer.

Razors, in tortoiseshell, pearl, plain and carved ivory handles; and with the "tang," or that part of the blade held while in use, made in ivory or pearl.

Razor blades in the different processes, from the bar of steel to the finished blade.

Penknives, pocket-knives, and sportsmen's knives.

Hunting knives, by which a broken stirrup-leather &c., may be instantly repaired. Office knife, containing pen-blade and paper cutter, pencil, and letter-weighting apparatus.—Both invented by exhibitor.

Portable slip knife and fork; the fork blade may be removed and replaced by a saw, file, button hook, &c.

German smoker's knife. Daggers, steel mounted, carved, and turned ivory handles. German hunting knife.

Cucumber slicer, which may be adjusted to any knife.—Invented by exhibitor. Tobacco cutter. Pair of skates, on an improved principle.

27 IBBOTSON, —, *Glasgow*—Producer.

Panel or block plane, capable of being altered to a mitre plane.

28 OFFORD, D., *Great Yarmouth*—Inventor.

Improved masticating knife and fork for dyspeptic persons. Provisionally registered.

[A masticating knife, so called from the minute state of division to which it reduces the food, consists generally of a number of blades, which, when acting on the food, divide it at one stroke into a number of portions. The utility of this invention, for those who require its assistance, appears to be established by experience.]

31 HANNAH, A., *Glasgow*—Manufacturer.

Assortment of Thomson's augers, braces, bits, claw and clench hammers, scollops, for boring wood, &c., of various dimensions and designs.

32 MATHIESON, A., *Glasgow*—Manufacturer.

Assortment of braces, bits; pianoforte-maker's key tools; turning and carving tools; chisels, gouges, &c. Mash, claw, veneer, and clench hammers. Saw buckles with swivel. Sets of screw augers. Sash and shutter cramps. Holdfast with swivel screw.

Flit ploughs with steel bridle and round brass stems; with improved angular slide; with screw stems; and with solid handle.

Sash and side fillisters, with improved stop brass stems.

Trying, jack, and smoothing planes.

33 HILLIARD & CHAPMAN, *Glasgow*—Inventors and Manufacturers.

1. The "Clydesdale razor"—a model razor on a large scale, exhibited for symmetry and execution.

2. The "people's razor."

3. The "organic razor." The angle of the edge is produced on the under side of the blade, and the principal concavity on the upper side. The configuration of the blade, at the point, heel and tang, is part of the improvement.

4, 5, 6. Additional samples of the "organic razor."

7. The "hypoetome, or beard plane," invented in 1851; new instrument for shaving; constructed on the principle of the carpenter's plane. It may be used with either right or left hand, and it admits of wiping, stropping or sharpening, like a common razor.

8, 9, 10, 11. Additional samples of the "hypoetome."

12. The "vallise strop," invented in 1851; containing the "hypoetome, or beard plane," shaving brush, shaving-soap, in case, and the strop.

13. The registered table knife, with invisibly secured handle. By a simple contrivance, incurring scarcely any additional labour, or expense in construction, the handle and blade are locked together, and cannot get loosened in use, while they may be readily separated for repair or renewal. The fastening is invisible, the handle showing no rivet, screw, or nut, of any kind.—Registered, March 7, 1851.

14, 15, 16, 17, 18. Additional samples of the registered table knife, showing the various patterns; with some of the handles left loose, to explain the principle of the invention.

19. Blade and handle of the registered table knife, in separate parts, the latter, sectionally divided, showing its internal construction.

20 The "superior family table knife." Exhibited for elegance, utility, and durability.

21. The "sporting gentleman's pocket knife," with graduated portable fleme.

22. The "improved pocket fleme-knife," for veterinary surgeons and grooms.

23. The "country gentleman's knife."

24. The "nude truss," for hernia. Exhibited for simplicity, lightness, and comfort in use. All padding or covering being dispensed with, it can be used while bathing, without being affected by the water.

34 SAUNDERS, G., *Broadway, New York*.

Four-sided metallic tablets and razor stropps.

35 MATHIESON, THOS. A., & Co., 65 *Nicholson Street, Edinburgh*—Manufacturers.

Improved sash fillister plane for windows; wood brace, brass neck, improved pad, and pattern bits.

36 MACPHERSON, C. & H., 1 *Gilmore Street, Paul's Works, Edinburgh*—Manufacturers.

A brace, with all kinds of bits used for boring, drilling, and countersinking.

37 BARKER, ROBERT, *Easingwold, Yorkshire*—Manufacturer.

Butchers' and house steels.

38 TOMLIN & Co., *Kettering, Northamptonshire*—Manufacturers.

Sickles for reaping corn, used in the midland counties. The teeth are cut fine and ground sharp without pulling out.

Shears used in sheep-shearing, wool-sorting, thatching, and carpet-making.

39 STUBS, PETER, *Warrington and Rotherham*—Manufacturer.

Blister and shear steel. Cast-steel, in the ingot and the bar. Coach-spring steel. Lancashire files and tools.

Magnets, made according to the system of the Rev. William Scoresby, D.D.; remarkable for their great power.

[Dr. Scoresby, who has devoted a large share of his attention to the construction of magnets, adopts the following mode of imparting magnetism to steel bars. He places the bar to be magnetised upon two powerful magnets, and then draws them gently apart until the upper bar rests with its ends on either end of the magnets; in this position it is allowed to rest for a short time, and then slid off laterally, the other side being turned down, and the process repeated until the bar of steel is thoroughly saturated. Dr. Scoresby insists upon the importance of using the hardest steel; and the most powerful magnets which he has constructed are made of a series of thin plates of steel, hardened throughout, each one of the series being separately magnetised.—R. H.]

Minerals, &c., from which magnets are made, viz., iron ore, from Dannemora, in Sweden; calcined ore; pig and bar iron.

40 GRADWELL, G., 8 *Market Street, Manchester*—
Proprietor.

Specimen of cutlery, knife with 300 blades, each having a separate spring.

42 BELCHER, ISAIAH, *Waterloo Street, Wolverhampton*—
Manufacturer.

Various augers, bits, borers, chisels, and gouges, for shipwrights, carpenters, coopers, pump-borers, and wheelwrights.

46 DURHAM, JOSEPH BANKS, 456 *New Oxford Street*—
Manufacturer.

Articles of cutlery. Highly polished and richly cut steel chatelaine, with improved scissors and tablet.

Series of blades, showing the various stages of a table knife, from the bar of steel to the finished blade.

47 HILL, J. V., 5 *Chichester Place, Gray's Inn Road*
—Manufacturer.

London-made saws; the blades, after they are ground, are filed to a gauge, so that there is no friction on the blade of the saw. Other tools.

48 BEACH, W., *Salisbury*—Manufacturer.

Assortment of cutlery, including fox-pad and fawn's-foot hunting-knives.

Newly designed pearl paper-folding knife, representing the crown, sword, and sceptre, with engraved views of Wilton House, Wilton Church, Salisbury Cathedral, and Stonehenge.

Carvers' pruning knives, shooting knives, &c.

Fine scissors, in newly invented steel cases for chatelaines. Model of Stonehenge.

49 EASTWOOD, G., 31 *Walmgate, York*—Inventor and
Manufacturer.

A panel-plane, answering the purposes of both panel and mitre.

50 BLACKWELL, W., 3 *Bedford Court, Covent Garden*.

Registered razor guards and razors, corn knife, corkscrew, &c.

(For Sheffield goods, see Class 22, Nos. 102—235, &c.)



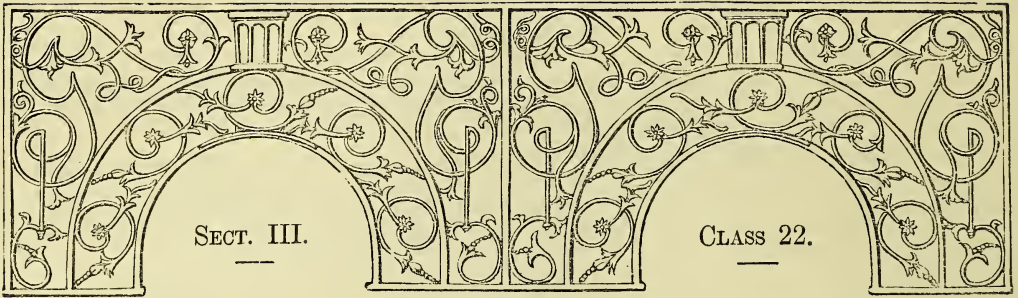

GENERAL HARDWARE, INCLUDING LOCKS AND GRATES.

INTRODUCTION.

THE smaller manufactures of iron, copper, brass, tin, &c., are represented by the objects contained within the limits of this extensive Class. These manufactures are of considerable importance to this country, and employ a large number of hands and a considerable amount of capital. But the objects themselves are often of the most trifling description; and were it not for the knowledge that upon their production depends the subsistence of many thousands of operatives, they might be passed by without notice. But in the manufacturing world the minutest article has its importance when the consumption of that article is great and the demand constant. It will consequently be found that the most insignificant object comprehended within this Class has important relations with the prosperity, not merely of a few individuals or of one manufactory, but of an entire district and its population.

The Class includes the following Sub-Classes:—A. Brass Manufacture, as Cabinet and General Brass Foundry, Hinges, Fastenings, Door-knockers, Castors, &c.; B. Copper, Zinc, Tin, Pewter, and General Braziers, as Kettles, Saucepans, Urns, Tubing, Inkstands, Spoons, &c.; C. Iron Manufacture, as Stoves, Grates, Fenders, Locks, Hinges, &c., and objects of a larger kind, as Mangles, Gates, &c.; D. Steel Manufacture, as "Heavy Steel Toys," such as Hammers, Vices, &c., and "Light Steel Toys," as Brooches, Buckles, &c.; E. Buttons; F. Wirework, Gauze, Hooks and Eyes, Pins, &c.

A considerable amount of space is occupied by this important Class in the Building. The articles comprised in it will be found on the South Side of the Western Main Avenue, to the West of the Colonial Productions. The Areas L. M. N. and O. 18 to 20, and 25 to 27, are occupied with these. Along a considerable part of the length of the Avenue O. P., Stoves, Pipes, Baths, Lamps, and a miscellaneous collection of Hardware of every description will be found.

Birmingham has long been connected with the manufacture of hardware of every kind, to such a degree that the name of the town has often become associated with these articles. Some departments of the trade are likewise vigorously pushed at Wolverhampton, Walsall, and Sheffield; but Birmingham may be legitimately considered as the metropolis for hardwares generally; and the enormous extension of its trade, attributable in a great measure to these manufactures, indicates the momentous results to which the production in quantities of the most trivial objects may give rise. In forty years the population of Birmingham has increased by nearly 150 per cent.; and what is highly instructive and remarkable is the fact that, in proportion to the increase of production has been the decrease of price, until there has been a reduction in the same period of about 62 per cent., and in some articles even to 85 per cent. The exports have likewise immensely increased in the same time: at its commencement they slightly exceeded 5,800 tons annually; in 1849, the exports amounted to 23,421 tons, the value of which has been estimated at about 2,201,315*l.* sterling. This relates merely to the iron manufactures: of the brass and copper manufactures were exported in 1849 to the value of 1,875,865*l.*; and it deserves notice, that the greatest proportion of these manufactures absorbed by any country is that annually imported by Hindostan—a country whose early reputation in metal manufactures is a subject of familiar knowledge.

The system of the manufacture of hardware in Birmingham is peculiar, and presents a striking contrast to that adopted in Manchester and other large manufacturing places—the operatives are themselves the manufacturers. Hiring a workshop in which steam-power is laid on, and which is specially fitted up by the owner of the building, in which many such workshops are contained, the artisan plies his peculiar trade, manufactures his articles, carries them home to the merchant, and receives the weekly payment for them, which enables him to procure fresh materials, and proceed in the ensuing week with his regular labours. A very large proportion of hardwares is thus manufactured. But this system is not universal; and regularly-organized factories, employing a large number of workpeople, and possessing all the distinguishing features of a great producing establishment, exist, and are in active operation. These establishments exhibit their beautiful productions in this Class.

The immense variety of articles included in this Class renders it impossible to refer in a succinct manner to any groups of objects; and this is the less necessary, as such objects must attract the notice they deserve on inspection, and fuller information may be found in this part of the Catalogue.—R. E.

- 1 HOOD, SAMUEL, 81 *Upper Thames Street*—Proprietor.
Improved ventilating stable stall, fitted with a cast and wrought iron hay-rack, and with an enamelled cast-iron manger and water-cistern.
Improved stench-trap of enamelled cast-iron.
- 2 SMALLMAN, SMITH, & Co., *Stourbridge*—Manufacturers.
Specimens of Wyatt's new patent method of glazing the surfaces of cast-iron articles, pumps, water pipes, cisterns, &c., viz., water-pipe glazed inside; and flanged suction-pipe of pump.
Specimens of glaze upon small pipe; upon a flat surface of cast iron. Cast-iron manger, glazed.
Specimen of fused glass, previous to being ground and mixed for use.
- 3 CLARKE, G. R., 2 *Somerset Place, Kennington*—Designer.
Designs for chairs in ornamental iron-work.
- 4 GUY, S.—Producer.
A variety of horse-shoes.
- 4A BARROW, —, *East Street, Marylebone*—Producer.
Patent window-sash.
- 5 KING, CHARLES, 5 *Tonbridge St., New Road, St. Pancras*—Designer.
Design for carriage-gates, to be executed in cast-iron; and for stained glass window.
- 6 PHILLIPS, J. B., *Battersea Fields*—Designer.
Design for ornamental iron gates, with suitable stone piers, for a park entrance.
- 7 STEVENS, HENRY ROWE, *Newmarket, Cambridgeshire*—Manufacturer.
Specimens of horse-shoes for hunters, hacks, racers, and carriage horses.
Narrow hind, fore, and broad plates for race horses, with thin-soled feet.
- 8 WOODIN, D., 28 *Shepherd Street, White Horse Street, Piccadilly*.
Patent shoes for horses or other animals, preventing their slipping on wood, ice, or any other surface.
- 9 MILES, W.—Producer.
Various horse-shoes.
- 10 WHITEHEAD, JOHN, *Oxford Street, Manchester*—Inventor and Producer.
Horse-shoes.
- 11 CHOPPING & MAUND, 370 *Oxford Street*—Patentees and Manufacturers.
Specimens of Rodway's improved patent concave horse-shoes, to prevent slipping on turf, wooden pavements, &c. Patent machine-made, fullered, and seated horse-shoes. Polished specimens of the same.
- 12 HOLMES, Captain—Producer.
Improved horse-shoes.
- 13 FOGARTY, JAMES, *Adam Street West, Bryanston Square*.
Horse-shoes.
- 14 HARLEY, JAMES, 3 *Cross Keys Mews, Marylebone Lane*.
Horse-shoes of a new construction, which prevents their being cast when hunting.
- 15 HILLMAN J., 4 *Leaver's Buildings, Glasshouse Yard*—Inventor and Manufacturer.
Concave expansion horse-shoe.
- 16 COOK, WILLIAM, *Willesborough, Ashford, Kent*—Manufacturer.
Horse-shoes in general use.
- 17 PLOMLEY, W., *Maidstone*—Inventor.
Model of an improved horse-shoe.
- 18 PEIRCE, W., 38 *Lloyd Street, Green Heys, Manchester*—Inventor and Manufacturer.
Registered letter-copying machines or presses; the required pressure being obtained by means of India-rubber or steel springs.
Model of a window with registered sash-fastener.
- 19 BAKER, EDWARD BRACKSTONE, 9 *Walbrook*—Designer and Inventor.
Simple and portable hand-pressure letter-copying machine, called a "manotype." The letter to be copied, together with a damped sheet or sheets of copying paper, are rolled together, with the India-rubber cloth, around the gutta-percha tube, and a very slight pressure of the hand produces a perfect copy: the interior of the tube contains copying ink, pens, and other requisites. Writing and copying paper are rolled round the "manotype," and the whole is enclosed in a small tin case.
- 20 RUTHVEN, JOHN, *New Street, Edinburgh*—Inventor and Manufacturer.
Letter-copying press, combining seal press and letter weigher. Its advantages are simplicity, power, and facility.
- 23 SYMES, WILLIAM, 19 *Victoria Road, Pimlico*—Inventor and Patentee.
Lump-sugar chopping-machines.
- 25 BARTRUM & PRETYMAN, *Brick Hill Lane, Upper Thames Street*—Manufacturers.
Wrought copper nails, roves, rivets, and washers.
- 26 RICHARDSON, ROBERT, 21 *Tunbridge Place, New Road*—Manufacturer.
Wire netting, to protect gardens and plantations; to enclose pheasants and fowls; and for a fence.
- 27 COOMBES, BENJAMIN, & Co., 30 *Mark Lane*—Manufacturers.
Fine twilled woven wire.
- 29 WALKER, EDWARD, 6 *Cardington Street, Euston Square*—Manufacturer.
Specimens of perforated brass, respectively containing eight thousand one hundred, ten thousand, and fourteen thousand four hundred square holes to the square inch; used for drug-grinding, glass-making, black-lead mills, and all purposes where fine powder is required.
- 30 WILKINS & WEATHERLY, 29 *High Street, Wapping*—Manufacturers.
Specimens of Smith's patent galvanized and ungalvanized iron and copper wire ropes used for railway inclines, various mining operations, including pit guides, suspension bridges, standing rigging, lightning conductors, window and conservatory sashes, fencing, and sub-marine telegraphs.
[Iron wire ropes are of equal strength with a hempen rope of four times the weight, and resist the wear and tear they are subjected to in "running gear" twice as long. If the surface of a wire-rope be left in any part unprotected by some coating impenetrable to moisture, the internal fibres become in process of time oxidized, and *unseen* decay goes forward. Iron cleaned by acid and plunged into a bath containing melted zinc, becomes coated with that metal, and the parts left uninked alone rust. Iron thus treated is said to be "galvanized."—S. C.]
Part of a bar of iron, rolled at Sharp and Brown's mills, Fazeley Street, Birmingham, drawn into wire so fine that it has been formed into a Prince of Wales' plume of feathers.

31 VERE, HENRY HOLTON, 2 *Andover Place, Kilburn*—
Designer and Manufacturer.

Improved bird-cage.

32 KUPER, W., *Surrey Canal, Camberwell*—Manufacturer.

Specimens of wire rope, in frame. Specimen of wire rope for suspension bridge; and fitted into pulley blocks. Wire rope jib stay. Specimens of wire rope, fitted with thimbles, &c. Specimens of flat wire rope and wire guides for pits. Galvanized wire strand for fencing. Copper lightning-conductors and sash line.

Specimens of submarine telegraph wire rope. Round wire rope prepared, for use. The improvement is stated to consist in preventing the wires and strands from being twisted on themselves, in the process of laying them round centre cores of hemp; in giving an equal tension to each individual wire; and in preserving the interior surface from corrosion by saturating the cores of hemp with tar, &c.

33 WOODS, W., 1 *Queen St., Southwark*—Manufacturer.

Hooks and eyes, for military and naval uniforms, and drapery purposes. Brass chains for lamps and scales.

34 BARNARD & BISHOP, *Norwich*—Manufacturers.

Ornamental Gothic hinge in wrought iron, with ivy leaf and stalk as a decoration.

Fourteen specimens of galvanized iron wire netting.

35 FOX, THOMAS HENRY, 44 *Skinner Street*—
Manufacturer.

Ornamental garden arch for training creepers. Wire flower-stands. Wire netting for aviaries, &c., and the exclusion of game. Ornamental bird-cages. Flower-trainers. Wove wire, fly-proof, dish and plate covers. Brass wire hangings, fire guards. Brass and copper wire, and weaving.

36 NEWALL, R. S., & Co., *Gateshead, Newcastle-upon-Tyne*—Inventors and Manufacturers.

Sample of wire strand, used for fencing, signal cord, &c. Sample of wire ropes. Wire rope for suspension bridges; and cable laid wire rope. Wire rope, showing the mode of splicing. Patent wire ropes for submarine telegraph; lightning conductor; copper window sash cord and picture cord. Patent flat wire rope, and guide rope, for coal pits, &c. Rope which has been at work constantly for five years.

37 REYNOLDS, JOHN, *New Compton Street*.

An ornamental wire flower table.

The accompanying illustration represents this table. The upper part is supported by three serpents of wire, which unite to form the legs of the table.

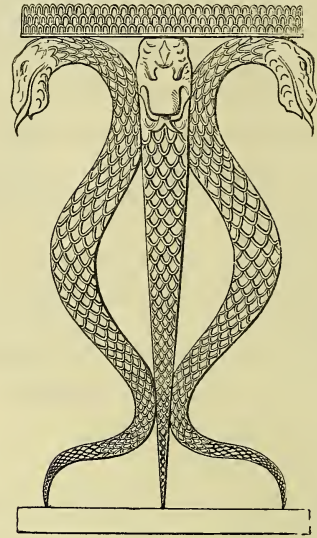

Reynolds' Wire Flower Table.

38 FLAVEL, SIDNEY, *Leamington, and 92 Jermyn Street, St. James's*—Inventor and Manufacturer.

Patent kitcheners or cooking grates.

This kitchener or cooking grate is remarkable for economy in fuel, having only one small fire placed in the centre, between two large ovens. These ovens can be converted into superior roasters by opening a small valve on the top, when a current of air circulates through the oven, carrying off every portion of steam into the flues. The closets at either end are applicable to keeping viands hot when cooked, or they can be heated for baking pastry, bread, &c. The hot plate on the top is capable of keeping in full work several steam kettles, stewpans, &c., and boiling or frying can be done over the fire at the same time; roasting can also be carried on before the open fire. At the back of the fire is placed a 50-gallon wrought-iron boiler, capable of supplying hot water to the upper part of the house, the draw-off cocks in front, the scullery and stable department if required, and also of supplying a bath placed in any part of the premises. Another feature in this kitchener, is the extreme cleanliness with which the cooking is carried on.

They are manufactured of various sizes.

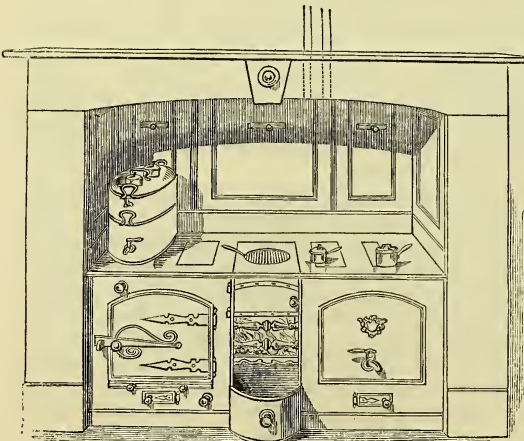

Fig. 1.

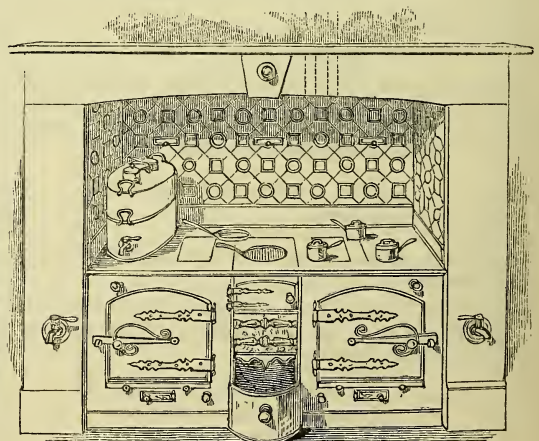

Fig. 2.

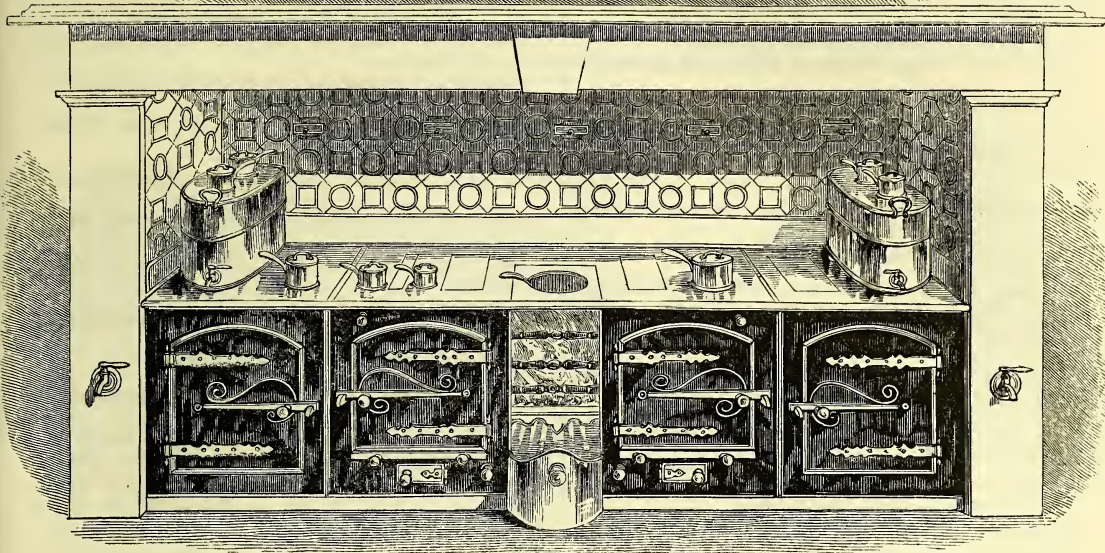

Fig. 3.

Flavel's Kitcheners.

39 GREENING, N., & SONS, Warrington—Manufacturers.

Extra strong wire-cloth, wove by steam-power, for wheat-screen, or drying kiln floor covering malt-kiln floor with only two joinings; for separating minerals, and various other purposes; for rice-polishing machines, &c.; made with flat warp, to increase its durability; for dressing rice, and for various other purposes.

40 GORRIE, THOMAS, Perth—Designer and Manufacturer.

Malleable iron garden chair. Wire-netting, for excluding hares and rabbits from gardens or fields. Land measuring chains with oval rings.

41 LINLEY, THOMAS, & SONS, 34 Stanley Street, Sheffield—Patentees and Manufacturers.

Patent circular double-blast bellows, in iron frame, complete and ready for work, equal in power to 32 long shape bellows, weight 180 lbs. They stand in half the room that long bellows do; effect a saving of twenty per cent. in fuel; every stroke of the lever produces a double quantity and force of blast; support a discharging pipe of double capacity; and iron and steel is brought into a state of fusion, without burning or injuring its properties, in about two-thirds of the usual time.

Improved circular bellows, complete, and ready for work; weight 150 lbs.

Patent portable forge circular bellows, with wrought-iron hearth, complete, weight 140 lbs.

Patent and improved portable forge with long bellows, complete; intended specially for the use of emigrants and for exportation, weight 130 lbs. It can be taken to pieces and refixed in a few minutes.

42 GREEN, ABRAHAM, 27 Upper George Street, Edgeware Road—Inventor and Manufacturer.

Protective syphon chimney-pot, for the cure of smoky chimneys; intended to create a draught, and prevent the wind blowing down the shaft. Applicable to any chimney.

43 DANNATT, JAMES, Norfolk Street, Sunderland—Inventor and Manufacturer.

Domestic mangle, which is said to possess the following advantages:—great simplicity of construction, not liable

to be deranged, power and efficiency in working, and diminished cost.

45 BRYDEN & SONS, Rose Street, Edinburgh—Inventors and Manufacturers.

An index dial bell with eight indicators, made upon a new and simple plan, by which one bell only is required for any number of apartments.

A manifold bell-pull, constructed upon an entirely new plan, by which one pull is made to ring bells in any number of rooms. When the pointer is placed opposite to any name on the dial plate, and the knob pulled out, the bell is then rung in the room indicated.

An improved circular telegraph bell, having two dials, numbered in the same manner, by means of which eight different clerks or workmen may be called.

An air signal mouth-piece and bell. By blowing into the mouth-piece the bell is rung, at any distance less than 1,000 feet. This is an improved method of ringing a bell in places too distant or not suited for working cranks and wires.

A single voice tube mouth-piece and bell-pull. When drawn out, the tube orifice is opened, and the signal bell being rung, the attendant is called to the other end of the tube.

A revolving mouth-piece for voice tubes, with bell-pull combined. Contrived so that one mouth-piece connects with six or any greater number of voice tubes, and at the same time with a similar number of bells.

Specimen of a self-closing-valve mouth-piece for voice tube; and of a spring covered mouth-piece for voice tube.

A bank-safe lock. The peculiarity of this lock consists in an extension of the key after it is inserted in the lock, and a secret connection between the interior of the key and two of the players. The two inclined planes on the under side of the wards open or shut the extension of the key as it passes over them; the part of the key thus extended operates on two players placed beyond the reach of picklocks, while, at the same time, the main part of the key works other two players, which are again operated on by the secret apparatus in the interior of the key. This secret apparatus can be removed at pleasure, and the proper key then becomes unfit to work the lock, and all

skeleton keys, however well fitted to pass the wards, will not operate on the players.

Specimens of drawing-room and dining-room lever and draw-out bell-pulls in ordinary use in Scotland.

Specimens of bells, mounted on brass carriages, steel springs, and steel pendulums, with concealed attachments for the wires.

A Venetian blind with a new spring roller.

An improved spring roller sun blind, with patent slip catch.

An improved spring barrel roller blind, with patent slip catch; free from noise when the blind is drawn down, and allowing the barrel to be easily taken down to be cleaned or repaired.

46 STEWART, CHARLES, 40 *Bell Street, Edgware Road*—
Manufacturer.

A playing ornamental fountain.

51 EDGE, JAMES, *Coalpool, Shropshire*—Manufacturer.

Model of a pair of pit frames, with barrel and flat chains. Wood and iron keyed flat chains, for pits of various sizes.

Improved straight-sided round chain, for naval and mining purposes. Horn-chain frames.

54 LAWRENCE, T. B. & J., 55 *Parliament Street*, and
10 *York Place, Lambeth*—Manufacturers.

British zinc ores and zinc first running from the same.

British zinc in ingots as merchandise.

Rolled zinc in sheets, plates, &c., various.

Perforated sheet zinc, for safes, larders, blinds, &c.

British zinc nails, &c.

British zinc in various manufactured articles, forming a small assemblage of the applications of zinc.

[The ease with which zinc can be turned into various forms, has brought the application of this metal into very general use; it is reduced into sheets from strips, by the ordinary process of rolling; when undergoing the same it is heated, but not to a high temperature; in soldering, the seam is touched with muriatic acid (spirit of salt) on the part to be united. Zinc may be drawn into tubes, &c., with facility, and stamped into various shapes.—W. C. A.]

A warming-bath, with iron grate and chimney pillars, and chamber for shower-bath, with brass force for repetition.

A lady's shower-bath, with hip-bath and force-pump.

Antique bath, in imitation of marble.

Knee-bath, with tube to vary temperature.

Hip-bath. Foot-bath, with rest and soap-dish. Sponging-bath. Foot-bath and can, japanned.

Coal-skuttle of British zinc, which has been in use 26 years.

Toilet pail and can. Coal-holding vessels. Closet pail with balance basin. Ice pail, with moveable perforated shelves.

Drawn lengths of rain-pipe. Drawn lengths of rain-shutes or gutters, cornices, &c.

Angles of connection. Cistern heads, or snow-boxes, various. Shoes for the same, various.

Drawn lengths of zinc tubing, for bell-hanging, conducting water, sound, &c. Drawn lengths of zinc window-bar.

Specimens of zinc plate engraving.

[A few years ago an attempt was made to substitute a zinc plate for the lithographic stone. The experiment, can scarcely be characterized as a successful one: the process of drawing the designer's subject was identical with lithography, as also the preparation of the plate for printing.—W. C. A.]

Vases in imitation of choice marble, with rare plants, as Ward's cases.

Lemon-shaped domes of bronzed zinc bar.

Pedestals of white zinc, for the same.

Ward's cases containing suitable plants.

Argonaut shell, suspended with gold wire, in engraved vase, a fac-simile of one in the possession of Her Majesty, with a rare plant in it.

Silver-gilt snuff-box with inscription.

55 TREGGON, H. & W., 22 *Jewin Street*, and 57
Gracechurch Street—Manufacturers.

Zinc window-blinds, perforated on one piece of metal, with varied designs.

Specimens of ornamental zinc mouldings, cornice, gutters, &c.

Patterns of drawn and moulded zinc bars, of metal sashes, &c.

56 SAVAGE, ROBERT WATSON, 15 *St. James's Square*—
Inventor.

Springs for all descriptions of doors. Bedstead for invalids.

Alarm bedstead, causing a person to arise at any given hour.

57 SMITH, THOMAS, 1 *Lordship Place, Lawrence Street*,
Chelsea—Inventor.

Portable folding wrought-iron bedstead.

58 TONKIN, JAMES, 315 *Oxford Street*—Designer and
Manufacturer.

Ornamented iron bedstead, of the Italian order, with registered spring lath bottom. This bedstead is represented in the annexed cut (p. 599), which exhibits the ornamental character of the bedstead, and the spring lath bottom.

59 COTTAM, EDWARD, 2 *Winsley Street, Oxford Street*—
Inventor and Manufacturer.

The rheioclone, or patent spring bedstead, exhibiting an improved form of spring mattress.

60 STEELE, W. & P., 61 *George Street, Edinburgh*—
Patentee and Inventor.

Kitchen range for culinary purposes, and apparatus for raising the temperature of water for baths and other uses.

The patent range is constructed, in all its parts, on scientific principles, and contains ample range bars for roasting and boiling, with one or more ovens, and a spacious boiling-table or hot hearth,—all of which are fitted up on the principle of perfect ventilation. A large boiler in the range affords a constant and ample supply of hot water, and is suited to cook by steam; also apparatus which gives the power of heating a reservoir of water at the top of the house, one hundred feet more or less above the level of the kitchen, from which reservoir hot water can be distributed all over the house, and by means of which a bath may be got ready for use at a moment's notice, during any hour of the day, or even at midnight, in cases of sudden indisposition. Means are also provided for effectually and speedily cleansing out the boilers, without further trouble to servants than merely turning one or two stop-cocks, so that hot water may at all times be had free of sediment and perfectly pure. The whole is effected by one open fire, before which meat may be roasted in the usual manner, besides effecting a saving of at least half the quantity of fuel used in apparatus of ordinary construction. This range can be made on a limited or extended scale to suit the accommodation required.

60A PERRY, E., *Wolverhampton*—Manufacturer.

Specimens of iron and tin ore; common and refined pig iron; bar and sheet iron; bar and sheet iron prepared for tinning; block tin; and tin plates.

Strong tin ware:—Basting ladles; coffee boilers and pots; cullenders, fish kettles; saucepans, and pans for milk; skimmers; slices; soup ladles and tureens; stew-pans; and tea-kettles, with and without stands.

Planned tin ware:—Bed-airer; bonnets; biscuit pans; caf ti res; candlesticks; canisters; oval cheese steamer and toasters; chocolate pots and mill; coffee biggins; boilers, filterers, and pots; covers for plates and dishes; egg poachers, codlers, and ladles; Etnas, for boiling

water; fish-knife; flour-boxes; graters; hot-water dishes and plate; inhaler; pepper-boxes; slices; strainers, for milk, gravy, and gruel; moulds; tea extractors, kettles, and pots; warmers, for carriage, for feet, and for stomach; wicker plate-baskets; wine mullers and strainer.

Japanned ware:—baths; bread and cake baskets; boiler fillers; bonnet boxes; botanical boxes; candle boxes and safes; candlesticks; canisters, round and square; cash-boxes; cheese trays; cigar trays; coal scoops, shovels, and

vases; date cases; dressing cases; ewers and basins; fire baskets and screen; gunpowder canister; hearing trumpet; inkstands; jugs; knife trays; lamps; lanterns; leg bath; letter cages; music stand; nursery lamps; plate carriers and warmers; sandwich and spice boxes; spittoons; snuffer trays; sugar-boxes; tables; tea caddies; toast racks; toilette sets; trays; umbrella stands; vegetable warmers; ventilators; waiters; water cans; wax boxes; and writing boxes.

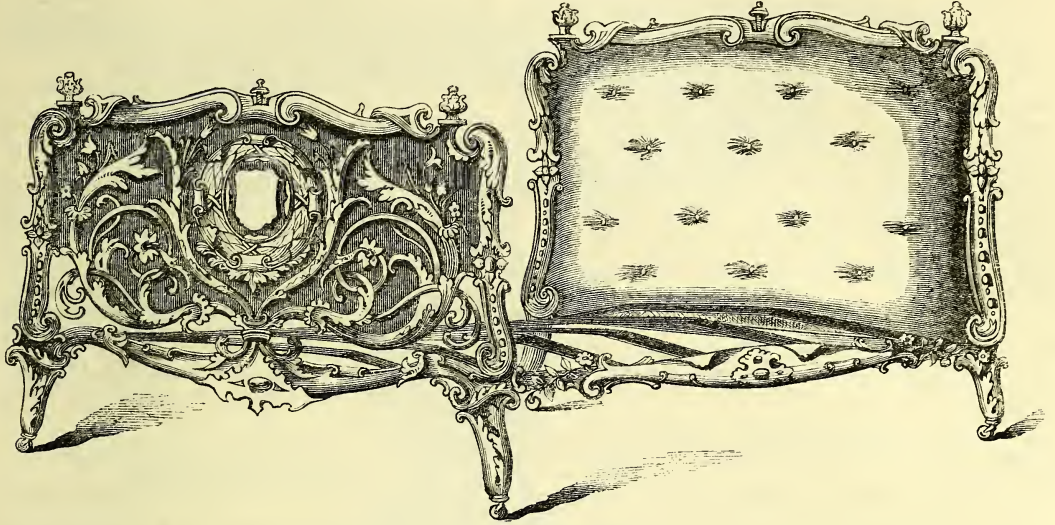

Tonkin's Ornamental Iron Bedstead.

62 COWLEY & JAMES, *Walsall*—Manufacturers.

Patent iron bedsteads, consisting of French half-tester and tent bedsteads. Child's cot in iron and in brass.

Samples of wrought iron gas and steam tubes and joints. One of these bedsteads is shown in the cut, in which its lightness and simplicity are represented.

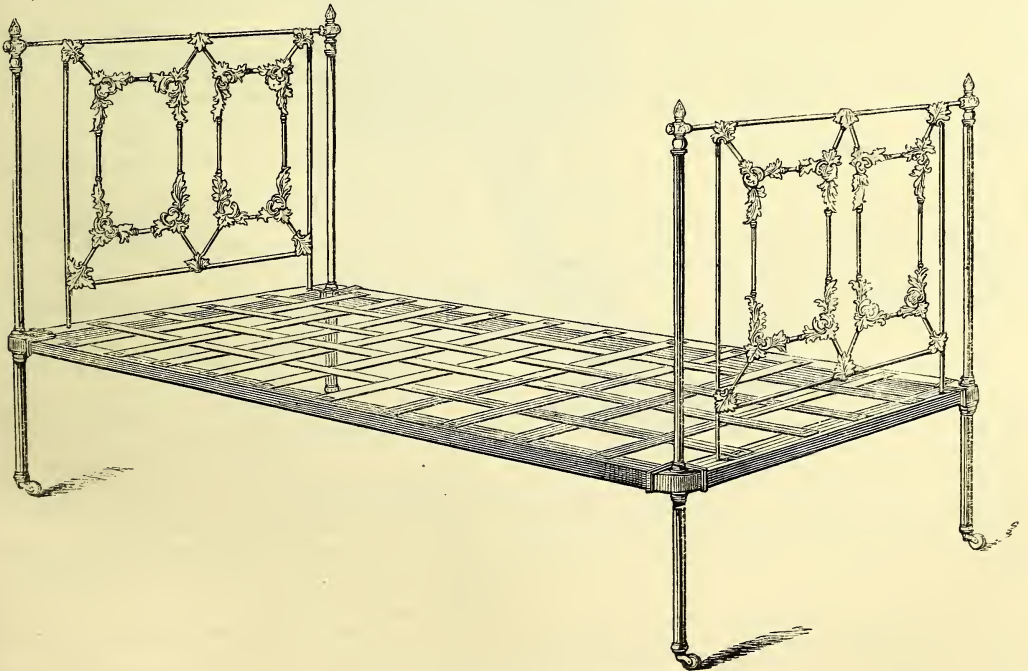

Cowley and James' Patent Iron Bedstead.

63 TYLOR & PACE, 313 *Oxford Street*, and 3 *Queen Street*, *Cheapside*—Manufacturers.

Specimens of perforated metal sheets. Specimens of patent iron bedsteads, child's cot, common iron stump

bedsteads, French bedsteads, and folding portable bedsteads. The novelty of these articles consists chiefly in the introduction of wrought-iron joints and drawn sheet-iron angle rails.

64 PERKES & Co., *Emerson Street, Southwark Bridge—*
Manufacturers.

Patent folding metallic bedstead, which can be used also as a crib, couch, &c. Registered.

65 HILL, EDWARD, & Co., *Brierley Hill Iron Works,*
*near Dudley—*Manufacturers.

Patent four-post iron bedstead, with pillars of taper iron tubing, &c., japanned fancy bead and foot-rails; and the parts united by ornamental castings.

Patent half-tester bedstead, with foot-rail, pillars of taper iron tubing, &c., fancy japanned and brass mounted.

Patent French bedstead, of solid iron, with fancy bead and foot-rails; and the parts united by ornamental iron castings.

Child's cot, of solid iron, with patent improvements, japanned blue, with brass top.

Patent half-tester cot, of solid iron, with patent improvements and registered safety sides, japanned bamboo.

All the parts fit accurately and can be put up and taken down by one person, without tools, being put together with patent dovetail joints, and fitted with patent iron lath bottoms.

66 SHOOLBRED, LOVERIDGE, & SHOOLBRED, *Wolver-*
*hampton—*Designers and Manufacturers.

Papier maché trays, in various styles. Coal vase, and scoops.

Shower-bath. Windsor hip-bath. Sponge-bath, with various ornaments and improvements. Nursery hand shower-bath.

Bear's patent coffee-pot, electro-plated on tin.

[The principle of pneumatic pressure is involved in the operation of this utensil: the upper portion of the pot may be considered a cylinder, in which moves the coffee-holder, which consists of a piece of cloth strained over what may be called a piston, the action of raising which, produces a partial vacuum, and the coffee is strained by passing through the sieve-like material of which the piston is composed, by atmospheric pressure.—W. C. A.]

Sets of toilet-ware. Wine-cooler. Dish-covers. Tea-pots, coffee-pots, and tea-kettles. Cash, deed, and writing boxes.

Date-dials for libraries, counting-houses, &c.

67 JOHNSON, EDWARD, 160 *Piccadilly—*Manufacturer.

Iron folding hinged bedsteads, with brass hinges and legs; with pole, having a ring at the top from which the curtains and drapery are suspended, capable of being packed in a small waterproof valise.

68 WHITFIELD, JAMES ALEXANDER, *Pelaw Staith,*
*near Gateshead—*Inventor.

Improved grappling or dredging-iron, for drawing from the water the bodies of persons apparently drowned.

The improvement consists in its passing over four times the space which the present irons pass over, and in the same time. In case of the hooks fastening at the bottom of the river they will straighten. The hanging-chain with the hooks will detect a body lying behind a rock or large stone. Made to take into pieces, so that it can be easily repaired.

69 WALTON & Co., *Wolverhampton—*Manufacturers.

Coal vase and scoop; enamelled foot-bath, pail, and sponging and milk-cans; block-tin dish covers; bronzed kettles and stands.

74 STIRK, J., *Salop Street, Wolverhampton—*
Manufacturer.

Engineers' anvil, timmen's anvil, and smiths' vice.

75 WOOD, GEORGE, THOMAS, WILLIAM, & HENRY,
*Stowbridge—*Manufacturers.

Wrought-iron anvil and vice, for smiths' forge.

Spades and shovels. Scythes and hay knife.

Grafting and draining tools. Pick. Frying-pan.

Link chains used in rigging of vessels, cables, and inclined planes. Swivel, used in chains, to prevent twisting. Shackle, used to unite pieces of chain together

Anchors. Card of nails.

Screw jack, for lifting wagons, boilers, and weights.

Model:—Winch for ships. Windlass for lifting cables, and steering barrel for vessels.

76 KEEP & WATKIN, *Foster's Works, Stowbridge—*
Manufacturers.

Spades and shovels used in the various counties of the United Kingdom, and in the colonies.

Set of improved cast-steel draining tools.

Round and oval frying-pans. Glaziers' foundry, and cooks' ladles, and tinned iron hand-bowls. Crown and patent garden, bramble, and grass scythes; and hay, chaff, and thatchers' knives.

Specimens of crane and coal chain.

Horse nails. Counter clout nails and cooper's rivets.

Various anvils. Coopers' beak iron and smiths' anvils.

Bright, staple, improved solid worm, screw box, vice, &c.

Best faggoted axle arm moulds, for carts and wagons.

Plough-share, beam, and coulter moulds, for foreign and home markets.

82 HANDYSIDE, ANDREW, *Britannia Foundry, Derby—*
Designer and Manufacturer.

Cast-iron fountain and vases, one a copy of the "Warwick vase."

An ornamental cast-iron vase, bronzed. (*Placed in the Main Avenue West.*) This vase is represented in the accompanying Plate 60.

Two cast-iron vases, from the Medici vase.

Two Bacchanalian vases, from the antique.

Two antique vases with scrolls.

83 THE BOWLING IRON COMPANY, *Bradford, Yorkshire*
—Producers and Manufacturers.

1. Iron ore, as raised from the ground.

2. Iron ore, calcined, ready for the furnace.

3. Best coal, for smelting the said ore.

4. Coke, produced from the same coal.

5. Pig metal, produced from the same ore, No. 1, No. 2, and No. 3.

6. Refined iron, from said pig metal.

7. Stampings from refined iron No. 6, puddled.

8. Railway wheel-tires, produced from No. 7.

9. Railway wheel tire, bent cold.

10. Railway axles, bent cold.

11. Samples of puddled iron, rolled and punched in different forms.

12. Round iron, tied in knots cold.

13. Marine boilers, flue iron.

14. Cuttings from boiler plates.

84 BATEMAN, JAMES, *Rolling and Wire Mills, Low Moor,*
near Bradford, Yorkshire.

Bloom of iron H. C., produced at East Ries, Norway, and generally used for wire for cards, and other purposes, where great toughness and strength are required.

Billet and wire rod rolled from the same.

Nos. 6, 9, 12, and 19, wire drawn from the same. Rolled into rods and drawn into wire by the exhibitor.

Various sizes of wire, from No. 24 to No. 38 wires' gauge, drawn from the same.

Various patterns of cards manufactured with the same wire by Daniel Bateman & Sons.

[The origin of the term "bloom" is not very evident; certain it is, that the most ancient iron-works in this country were called "bloomeries," or "bloom-smithies." Blooms are lumps of iron, and are produced in such a way as to ensure great toughness. Such as the one exhibited are usually formed by melting slags in fur-

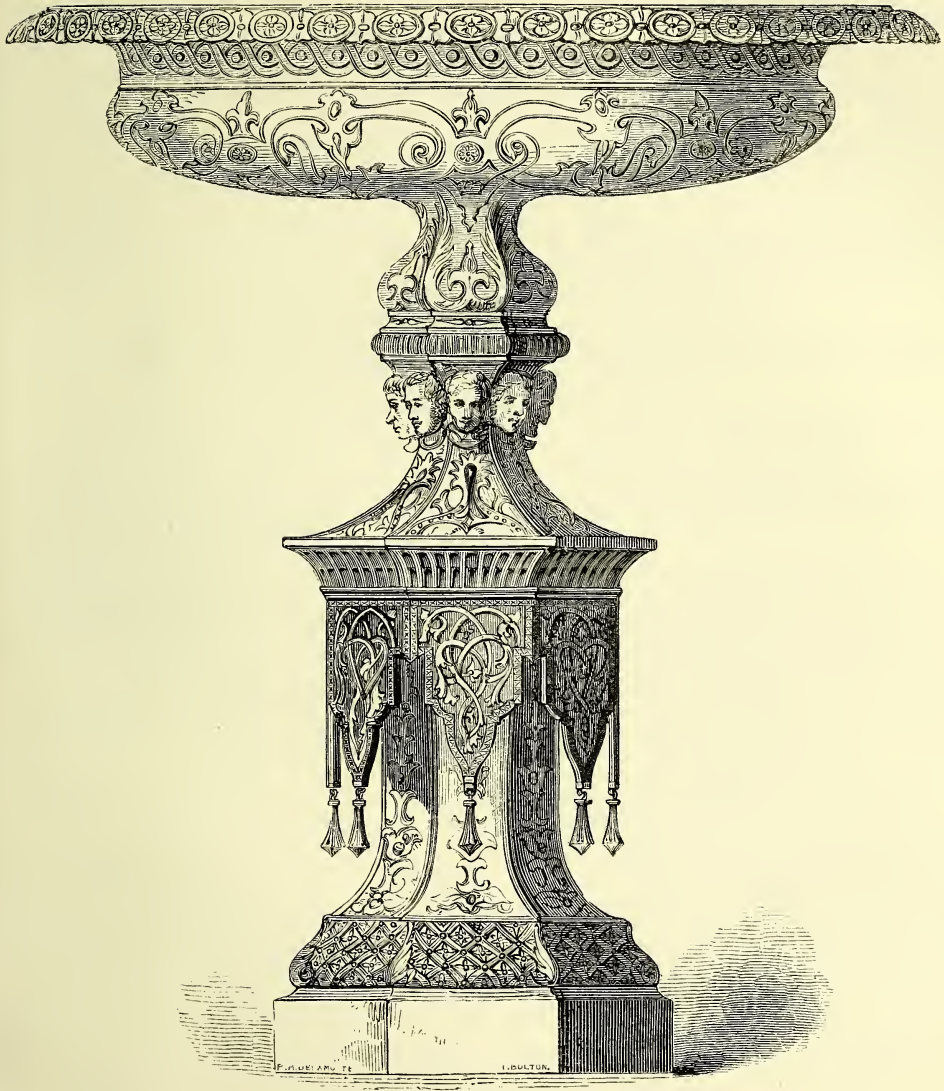

CAST IRON VASE. MR. HANDYSIDE.

naces at such a moderated heat that time is allowed for the metal to separate from the silicious matter which contains the impurities, which then runs down into a basin, where all the particles get agglutinated and form a pasty mass, which is removed by a hooked pole in order to be forged; the formation of each bloom of malleable iron requiring a period of from three to four hours for its production.—R. H.]

85 **HIRD, DAWSON, & HARDY, Low Moor Iron Works, Bradford**—Producers and Manufacturers.

Minerals from the Low Moor Company's mines, near Bradford. Black ironstone, an argillaceous iron ore, yielding 28 per cent. of pig iron. Requires a limestone flux. Black bed coal, found immediately under the ironstone, about 28 inches thick. Better bed coal, found 40 yards below the former, about 22 inches thick. Specimens of Low Moor pig iron, and of wrought iron in various shapes; some tested by tension and otherwise.

Ten-inch gun of 9 feet 4 inches, weighing 85 cwt., used with hollow shot, shells, grape, and canister shot. The charge of powder is 12 lbs., and reduced charges are used for short-range shells. When fired with a hollow shot of 84 lbs., and an elevation of 5°, this gun has a range of 1,700 yards. Mounted on a carriage (made by Messrs. C. A. & F. Ferguson, Mast House, Mill Wall, London) with slide and appurtenances, with improvements to facilitate the working and training, and checking the recoil, of heavy guns. Thirty-two pound gun, of 6 feet, weighing 25 cwt., used with solid shot, shells, grape, and canister shot. The charges of powder vary from 2½ to 4 lbs. With a charge of 4 lbs., and fired at an elevation of 5°, the range is 1,500 yards. Mounted on a similar carriage, for broadside and quarter-deck purposes.

Sugar-cane mill. Cylinders or crushing rolls, 24 inches diameter by 48 inches in length, to be driven by steam or water-power. Olive mill. Cylinders or crushing rolls, 10 inches in diameter, by 20 inches in length; to be driven by cattle, steam, or water power.

Wilson's elliptograph, for drawing ellipses of any proportion from a straight line to a circle.

86 **ELLIS, WILLIAM, 136 High Street, Isle of Wight**—Manufacturer.

Kitchen-range, and hot-plate over oven for roasting, boiling, baking, and stewing, heated by one fire. Boiler fitted to the same, for heating steam-kettles, steam-closet, and baths.

87 **NICHOLSON, WILLIAM NEWZAM, Newark-on-Trent**—Inventor and Manufacturer.

A cottage cooking-grate, with improvements, registered by the exhibitor, under the patent of John Leslie, of London. The improvements claimed consist of a fire-brick lining, an improved form of fire and range, which retains the fuel till all is consumed, and slides in grooves so that the remains of a fire can be cleared out in an instant.

A cottage chamber grate, with similar improvements.

Cottage range for farm kitchens, or other large establishments, with similar registered improvements; and a spacious oven, hot-water boiler, steaming closet, and warm closet, all heated from a fire of moderate size.

A cooking-grate for cottages and emigrants, complete without setting, with oven and capacious boiler, the upper surface forming a hot plate or ironing stove.

A cottagers' cooking-grate, with oven.

A cooking-range for large establishments, forming a complete stove for roasting, baking, boiling, &c.

A grate suitable for dining-rooms, exhibiting a new combination of colour with steel or iron-work.

Three-light bracket for gas, made of iron, with a brass burner.

Mediæval bracket for lights for a baronial hall, manufactured of iron and polished.

Specimens of decorative work in wrought and cast-iron combined.

88 **COLLINS, JOHN, Leominster, Herefordshire**—Inventor.

Models of patent inventions, &c.:—Stove for warming and ventilating buildings.

Stove grate for warming and ventilating rooms, &c.

Kiln for drying malt, hops, and other substances.

Machine for separating the parts of hops.

Structure for the better management of farm-yard manure.

89 **DULEY, JOHN, Northampton**—Inventor and Manufacturer.

Registered self-acting effluvia-trap.

Patent cooking-stove.

90 **SHAVE, W. J., 74 Watling Street, Inventor and Manufacturer.**

Patent oven, for baking bread, pastry, meats, &c. Exhibited for economy of fuel and time.

91 **SHARP, JAMES, Southampton**—Inventor and Manufacturer.

Apparatus for cooking by gas a dinner for one hundred persons.

[Dr. Clayton, in 1739, boiled eggs by means of gas; Mr. Murdoch, in 1792, boiled and fried meat by gas; and in 1824 a gas cooking stove was in use at the Etna Iron Works, near Liverpool.—S. C.]

92 **KERSLAKE, THOMAS, Exeter**—Manufacturer.

Registered boiler for heating churches, mansions, manufactories, &c.

93 **HALSTEAD, CHARLES & SONS, Chichester, Sussex**—Manufacturers.

Kitchen-range, with mantelpiece, combining all the conveniences of a close range, with a large open roasting fire, large oven and hot plate, and good supply of hot water.

94 **KEENE, W., 42 Cornhill, and 19 Harpur Street, Bloomsbury**—Inventor.

Registered conducting leaf stove, adapted for heating large apartments in houses exposed to a north-eastern aspect. The difficulty of heating large rooms to a comfortable temperature, in the depth of winter, led to the invention of the stove exhibited. In an apartment almost insensible to the action of the ordinary fire-place, and in which the thermometer indicated but a feeble tendency to rise two hours after fire-lighting, it was affected to the extent of 20 degrees in little more than as many minutes after lighting a fire in the leaf stove. The sensitiveness of the leaves to the diffusion of heat is so great that the combustion of a few shavings or a little paper in the fire-place is immediately and sensibly felt in the apartment. Such a result, obtained not only without any sacrifice of, but in addition to, the comfort of an open fire in the ordinary fire-place, clearly demonstrates the value of the heat which we permit to pass up the chimney. By the leaf stove it is rendered available, and made to circulate in the apartment, or may be shut off at will.

The conducting leaf stove is formed of plates of metal so placed that each one is a conducting leaf, a portion of which goes down, as it were, into contact with the fire, and is exposed to the direct action of the heat. The heat thus received is rapidly distributed over the whole surface of the leaf. When it is desired to take advantage of the heat communicated by conduction, it is only needful to set the valves open, and permit the air to circulate around the leaves; by closing the valves, the circulation is suppressed or modified at pleasure. The rapidity of the conduction of the heat prevents the metal attaining a high temperature. The principle of this stove is to diffuse a large volume of air at a genial temperature by the conducting power of extensive surfaces. In ordinary stoves, masses of metal heat small volumes of air to a high temperature, by which it is rendered unwholesome. This stove and its interior construction are shown in the next page.

The principle of the conducting leaves can be applied in a great variety of forms, and to the construction of

stoves of any size, for heating vestibules, hospital wards, churches, and public buildings generally, and can be kept within the limits needful for the invalid bed-room or smallest apartment.

Fig. 1.

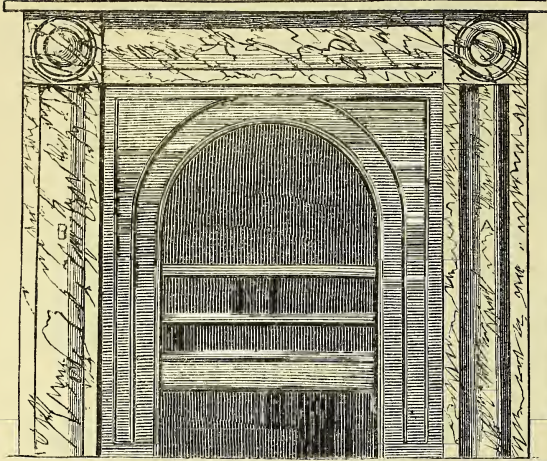

Mr. Keene's Conducting Stove.

A is the valve partly opened. B is the valve shut.

Fig. 2.

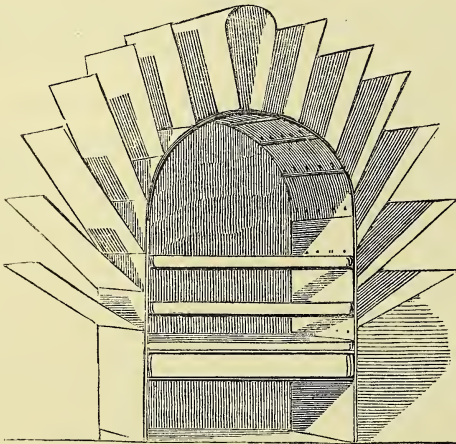

Interior of the Stove, showing the Conducting Leaves.

95 POWELL, W.—Inventor.
Portable economical oven.

96 HARPER, A., & SONS, *Dudley*—Designers and
Manufacturers.
Fender, or-molu mounted. Pierced fire-guard. Kitchen
fender. Best steel fire irons.

96A FIRTH, THOMAS, *Eliza Street, Belfast, Ireland*—
Proprietor.
Registered model fire-box, with hollow fire bars, for
locomotive and other furnaces.
See also Class 5, No. 472, with cuts.

97 HAYWOOD, JAMES, *Derby*—Manufacturer.
Burnished steel drawing-room stove, with porcelain
hearth and black marble chimney-piece. Radiating hall-
stove, with hearth-plate. Church-stove.

98 BENHAM & SONS, *19 Wymore St.*—Manufacturers.
Oxford roasting range with radiating back.
Improved Oxford range with oven. Fitted also with
smoke jack, with double outside movement, chains,
cradle, spit, beef and mutton. (See the annexed cut.)

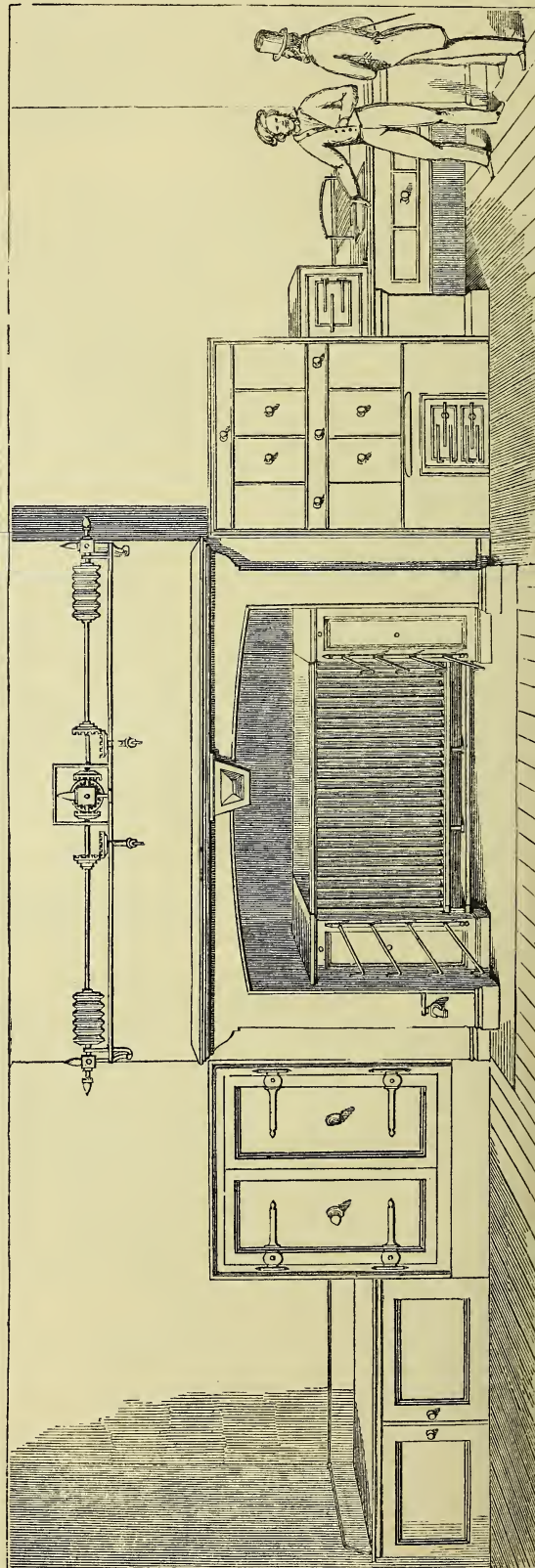

Benham's Improved Oxford Range.

Also with hot-plate and broiling stove, with oven for pastry, &c., to be heated by one fire; moveable gridiron, &c.; charcoal stoves; steam-table for dishing up; hot closet with folding doors, to be heated by steam or hot water; large oven and furnace with closet above; bain-Marie pan for keeping gravies and sauces hot; vegetable steamer and trays; steam-kettles, copper brazing-pan, fish-kettle, stock-pot, and stew-pans.

Copper warm-bath, with cocks and lever handles.

Copper suspending shower-bath. Portable warm bath. Cottager's stove. Shrapnel's new system of bell-hanging, without wires or cranks. Stove-grates.

99 THOMAS, W. H., 174 *Sloane Street*—Producer.
Dining-room fire-screen.

100 COLLIER, SON, & SNOWDEN, 10 *Foster St., Bishopsgate Street*—Patentees and Inventors.

Patent porcelain enamelled coffee-roasting cylinder, thickly lined inside to prevent the possibility of scorching or charring the coffee during roasting, and prevents the berry from imbibing that metallic or vaporous flavour, so much complained of in coffee roasted in the ordinary common iron cylinders. The metal of which these cylinders are composed is altogether different to any hitherto employed for that purpose.

The wire cylinder is used for purifying or cleansing coffee that has imbibed offensive flavours during importation. It is likewise applied for cooling coffee after roasting, by the introduction of atmospheric air; it is cooled in a few minutes, and may be packed for any distance, without the essential oil starting from the berry, by what is generally known in the trade by the term sweating.

101 LESLIE, JOHN, 59 *Conduit Street*—Inventor,
Patentee, and Manufacturer.

Patent fire-brick grate for drawing-rooms. The back, bottom and sides are of fire-brick, &c., the only admission of air being in front, a more effective combustion of the fuel is accomplished, whereby greater heat radiates into the room with a saving of 50 per cent. of coals, coke, or wood.

Patent fire brick dining-room or library grates, bed-room grates, labourers' cottage grates, and oven, boiler, and steaming apparatus for cooking purposes.

Patent domestic gas purifying apparatus, whereby great sanitary and economic results are obtained in the combustion of gas. Patent gas regulating apparatus, to equalize the flow of gas.

Patent 28-tube gas burners, with glass combustion chambers, graduated for given quantities of gas, whereby the largest amount of light of which the gas is susceptible is produced without changing the burner.

102 STUART & SMITH, *Sheffield*—Manufacturers.

Specimens of Sylvester's patent grates, exhibited for novelty of principle, design, and workmanship.

Patent register grate, with a revolving canopy; on a new principle.

The mantelpieces manufactured by Messrs. Nelson, of Carlisle.

Fenders, fire-irons, &c., exhibited as specimens of design and workmanship.

Ascending and descending air stoves, suitable for entrance halls, &c.

Three miniature steam-engines, in brass, complete; worked both by steam and clock work. The largest weighs 2½ ounces, the second only ¾ of an ounce, and the smallest ¼ of an ounce. Made by W. Hurst, Sheffield.

103 EVANS, JEREMIAH, SON, & Co., 33 *King William Street, London Bridge*—Manufacturers.

Burnished steel drawing-room register stove, fender, and fire implements *en suite*, mounted with or-molu ornaments.

A kitchen-range, with two wrought iron boilers (for steam and hot water), the hobs and fronts polished, the latter fitted with Berlin black pannels; the bars are bright, vertical, and made to open after the manner of a gate, with two winding cheeks and trevets, made to work in an improved manner.

A broiling-plate, with loose ring tops, made to correspond in style with the range.

A steam hot-closet, with copper shelves, with double doors, finished in same style as range; copper steam-kettles, stewpans, &c.

A complete double oven, with dead sprung fronts, bold O G mouldings, sliding pannel doors; also made to correspond with range.

A smoke-jack, with double outside movement and dangles, adapted to turn six spits, or more.

A highly-finished warm-air stove, black polished, with mermaid ornaments at the corners, ashles-grate and fender, adapted for the state cabin of a ship.

A classic bronzed pedestal lamp, adapted for an entrance hall, with three patent Argand burners and glasses.

A bronzed trophy or shield, with brass ornaments, sword, sword-belt, &c.

Brass and black dogs for wood fires.

Improved kitchener; or cooking apparatus, so arranged as to form either an oven or close fire, with a large roasting oven, wrought iron boiler, &c.

A black register stove, in the Elizabethan style, with fire-brick back, fender and fire furniture to correspond.

A dead-sprung register stove, with canopy of Italian bronze, lizard ornaments, bright bars, &c.

104 MORTON, J., 32 *Eyre Street, Sheffield*—
Manufacturer.

A cast-iron table, with marble top, and an or-molu fender. Berlin and bronze fenders.

105 LONGDEN & Co., *Sheffield*—Designers and
Manufacturers.

Cooking apparatus, adapted for an opening eight feet wide, by five feet high, and containing an open-fire roasting range, with sliding spit-racks and winding cheek or niggard; a wrought-iron boiler, holding thirty gallons, prepared for supplying hot water to an upper chamber; a wrought-iron pastry oven, having the top made hotter than the bottom, thereby insuring the pastry being lighter and more wholesome than in ovens on the old principle; a hot hearth, heated by the oven flue, intended for boiling fish and vegetables; three stewing stoves and one oven, to be heated by gas, for boiling, frying, baking, or roasting, which may be regulated at pleasure by the gas cocks. Meat roasted in the gas oven is said not to waste away in the same proportion as when done before the fire, and as the dripping falls upon a cool pan it is not burnt or discoloured, but rendered fit for culinary purposes. The two hot hearths are surrounded by cove plates, which are so arranged as to protect the cook from the heat of the open fire.

Warm-air stove, heated by gas placed in a wrought-iron interior, with escape pipe at back, and having the exterior perforated throughout for the escape of warm air.

Specimen stair balusters and newells, in various styles of ornament.

Gallery front for entrance hall, &c., consisting of a panel in Roman style, surrounded with mahogany rails and pillars. The various scrolls and foliage of this design are carved on both sides, and intertwined with the railing bars, in imitation of a natural growth.

Perforated pedestals for enclosing coils or tiers of pipes, heated by the circulation of hot water, with marble slab at top, used as hall tables, &c.

106 JOHNSON & Co., *Sheffield*—Manufacturers.

Patent bright steel light and heat reflecting stove-grate, with white marble chimney-piece, overlaid with gilt ornaments in the renaissance style. This grate is

considered to combine economy with powers of heating and ventilation; the reflector is movable upon a slide-hinge for ventilation, taking out the ashes, and sweeping the chimney. Suitable for drawing-rooms, &c.

A burnished steel register-stove, with white marble chimney-piece; the stove ornamented with twisted steel mouldings, gilt coronet, and silver feathers, and there is also a steel ash-pan fender with polished moulding, and ornaments similar to the stove.

A bright patent air-stove; the design forming a pedestal. Suitable for entrance halls, &c.

Parlour cooking-stove. The advantages of this grate consist in its forming a chimney-piece, with open fire register-grate, and portable oven for cooking. Suitable for cottages, lodging-houses, &c.—Invented by Henry Laxton, architect, 9 Pall Mall East.

106A LAXTON, H., 19 Arundel Street, Strand—Inventor.
Parlour cooking-stove.

107 PIERCE, WILLIAM, 5 Jermyn St.—Designer, Inventor and Manufacturer.

Stove-grate, in the Elizabethan style, with fender and fire-irons *en suite*.

Drawing-room stove-grate, in style of Louis Quatorze, and chimney-piece of cast iron, enamelled in the enriched style of the period. Fender, in or-molu, formed of vine leaves, tendrils, and clusters of grapes, the supports for the fire-irons being branches of the vine with bunches of grapes suspended. Fire-irons *en suite*, of polished steel, having spiral stems, the pan of the shovel engraved, and the or-molu heads composed of vine leaves and grapes. This grate is represented in the illustration below.

Bevilled register stove grate. Bronzed fender and fire-irons.

Elizabethan chimney-piece, of British alabaster, by Henry Poole, mason; and the hearth of specimens of British marble, the outer border in Sienna.

Registered pyro-pneumatic warming and ventilating stove-grate, suitable for the entrance-hall or staircase of a nobleman's mansion; the outer casing of cast iron, ground, polished, and browned. The interior is of prepared fire-clay, moulded in various pieces. This stove is represented in the following cut.

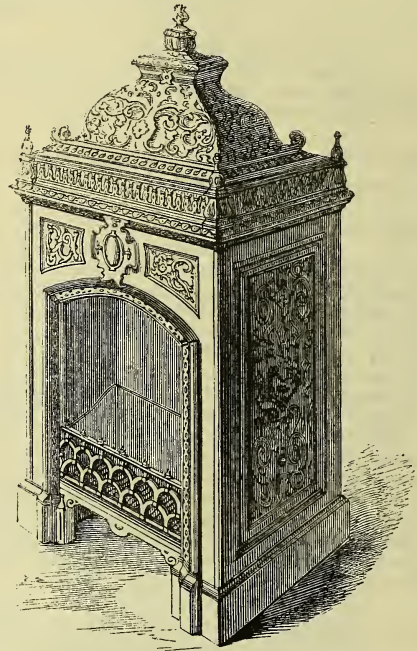

Pierce's Pyro-Pneumatic Stove-grate.

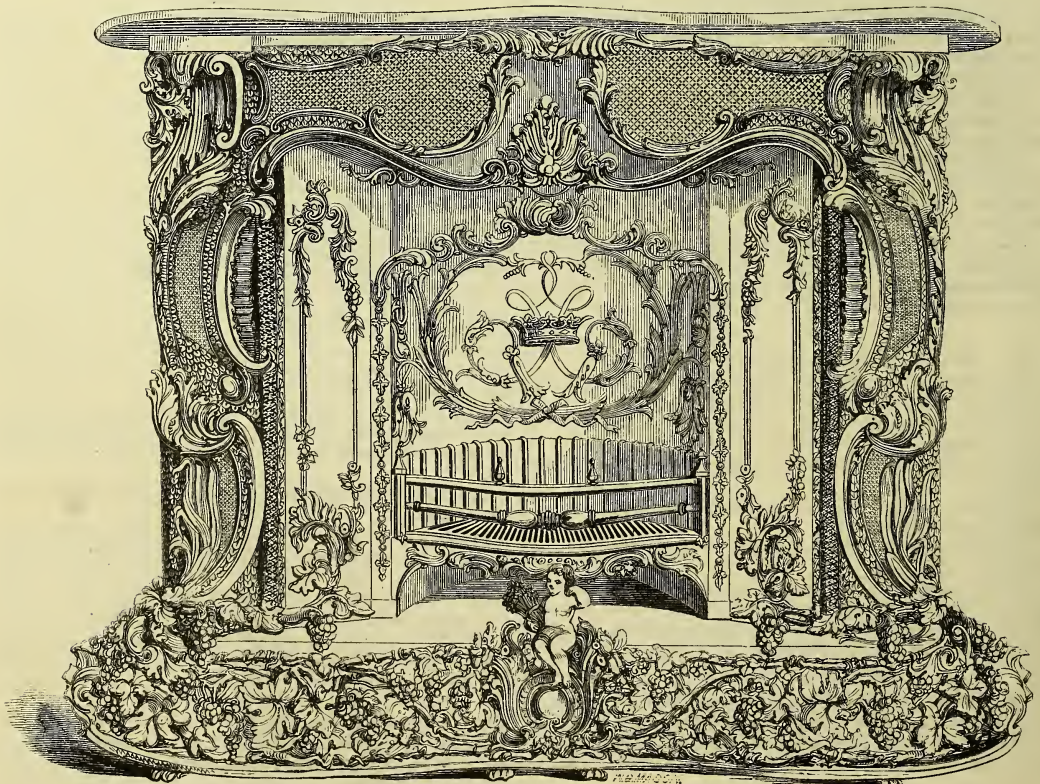

Pierce's Louis Quatorze Drawing-room Stove-grate.

Gothic pattern stove-grate, for a church or school.
Registered cottagers' and other fire-lump grates.

Chased fender, in or-molu; consisting of dogs, stags, and foliage. This fender is represented in the annexed cut.

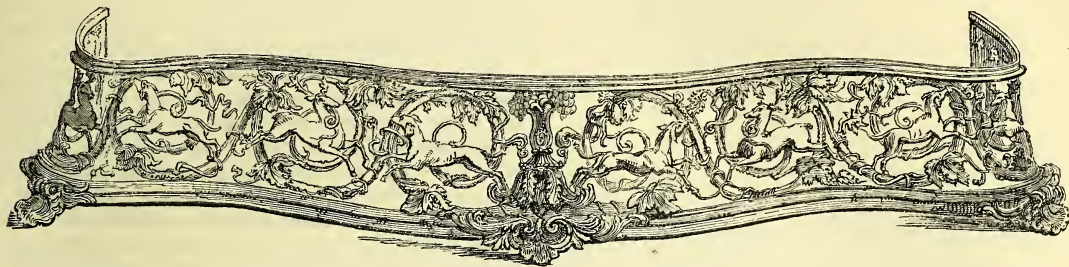

Pierce's Chased Or-molu Fender.

Drawing-room and other fenders, &c. Antique bronzed pendant bell-handle.

A pair of ornamental fire-dogs. These are shown in the following cuts.



Pierce's Ornamental Fire dogs.

108 CARR & RILEY, *Bailey Lane Works, Sheffield—*
Manufacturers.

Patent double-edge Lewis and spiral machine knives, for dressing cloth. Ledger blade, and spring bed to work with the same. Bayonet spiral machine knives.

Circular, frame, and pit saws. Mill-saw web. Skinner's slitting-knife. Machine-knife, for cutting tobacco. Machine-plane and moulding irons. Files, assorted. Large file, with views and designs.

109 JOHNSON, CAMELL, & Co., *Cyclops' Steel Works,*
*Sheffield, Yorkshire.—*Manufacturers.

Model of the Cyclops' Works.

Various specimens, illustrative of the conversion of iron into steel: comprising the raw iron, blister-steel, spring and shear-steel, ingot cast-steel, and cast-steel of various kinds, for engineering and mechanical use.

Cast-steel forging of large marine piston-rod.

Cast-steel locomotive piston-rods and cover.

Axe, hammer, tool, chisel, tap, die, sheet, pen-machinery, and other steels.

Specimens of files and rasps, for the use of engineers, machinists, smiths, and saw-makers; cabinet, clock and

watch-makers; silversmiths, jewellers, &c., combining every variety of shape, cut, and dimensions, from one to forty-six inches in length; including the concave and convex file, with continuous tooth, and a silversmiths' rubber, six inches broad, supposed to be the greatest breadth of surface ever cut with the continuous tooth.

Specimens of locomotive engine, and railway-carriage, carriage-truck, horse-box, van and waggon, bearing, buffer, and draw springs, with their respective stoops or boxes. Improved springs for traction or buffing, elliptic and spiral.

Springs for road-carriages, and various specimens of wrought-iron work, for hanging railway-carriages.

110 DEAKIN, G., & Co., *48 Eyre Street, Sheffield—*
Manufacturers.

Ivory carvers; plated fish carvers. Silver and silver-plated dessert-knives, various; round-of-beef slicers, ivory handle, silver ferrule, with a crank in the trowel part, gilt and etched blade.

Ivory, silver, and plated table-knives. Silver knife, fork, and spoon, Albert pattern. Ivory game-carvers. Silver cake-knife. Ivory and pearl table-knives, silver ferrules, gilt blades.

A silver fish-carver and fork of a new design. These are represented in the annexed cut.

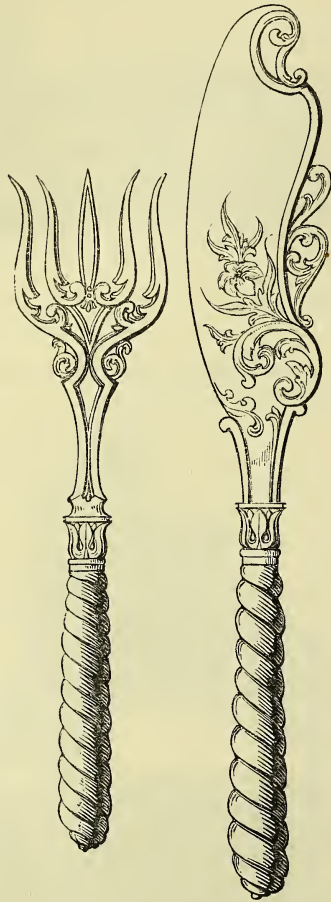

Deakin's Fish-carver and Fork.

110A BROOKES, WM., & SONS, *Sheffield*—Manufacturers.

Emigrants', horticultural, and gentlemen's tool chests, complete, of various sizes.

Canadian and Brazil wedge axes. American and Australian felling, siding, and squaring axes.

Hammers, for various purposes. Axes, hatchets, and stone-picks. Coopers' sharp and nail adze, howell, froe, and driver. Carpenters' and wheelers' adze. Sugar-choppers. Bright choppers.

Cleavers, with iron handle; American cleaver; mincing knives; and cheese knives.

Farmers' chisels and gouges, in cast-steel. Millwrights' chisels and gouges. Turning chisels and gouges. Socket chisels and gouges. Mortice chisels. Plane-irons; plough bits; and moulding-irons.

Spanners, single and double-ended improved shifting screw-keys. Coach wrenches.

Improved cylinder and best double railway wrenches. Screw stocks and dies, with taper and plug taps.

Racket brace; screw plates; spring dividers; and callipers.

Various compasses, pincers, nippers, punches, and plyers, for different purposes.

Pinking irons; sheep-markers; patent saw sets; steak tongs; flesh forks; candle snuffers; and nutcracks.

Garden tools of every description; pruning shears; grape gatherers; avarancaters; pruning scissors; vine scissors; and flower gatherers.

An assortment of table cutlery.

112 MAKIN, WILLIAM, *Attercliffe Steel Works, near Sheffield*—Manufacturer.

Paper-mill rag-engine, with roller-bars and bottom plates, made of the best cast-steel; it is intended to be used for grinding ropes, rags, and other materials into the pulp, employed in the manufacture of paper.

[Rags, rope, &c., or the materials of which paper is made, must be reduced to a state of pulp; to accomplish this there has been many modes devised, but that in which the roller-bars and bottom plates are used, is said to be the best. The intention of the roller-bar, in the first place, is to assist in washing the rags, and secondly, when brought to a nearer connexion with the bottom-plates, which is placed at the bottom of the cistern, to break the fibres, which are then passed away in a filmy state. The water being dissipated, the minute fibres are deposited on a surface or cylinder, and after undergoing the drying process, &c., eventually become paper.—W. C. A.]

Plates of cast-steel, polished on both sides.

Knives for rope and rag-cutting machines; horizontal cutters; doctor blades for paper machine rolls; circular cutters and slitters; crosscutting, bench, and reel knives; rope and rag axes, and choppers of various patterns.

Tobacco-knives; snuff-knives; Miller's refined cast-steel chisels and picks; paper makers' rag-sorting knives, &c.

Samples of blister, bar, shear, and cast-steel, used in the various branches of the manufactures of Sheffield.

Samples of cast-steel, used in the manufacture of wire for needles, hackle-pins, &c., also by engineers, machine-makers, and ironfounders.

113 SPEAR & JACKSON, *Sheffield*—Manufacturers.

Cast-steel circular saw, 5 feet diameter, machine ground and polished. These saws are toothed with a dividing engine which renders them regular on the edge, and are ground and polished by a new machine.

Specimen of a spring steel handsaw, 30 inches long, with polished blade, and French polished ebony handle, German silver electro-plated shield and screws.

Handsaws, and bright, blue, and brass backsaws, with polished blades, French-polished handles of various kinds of wood, and German silver, brass, or polished iron screws; mill-saws, pitsaws, crosscut saws, segment, and other kinds suitable for the home and foreign markets.

Ledger blades and spiral cutters for shearing cloth; sheep slitting knives, hay and straw knives; tanners and curriers' knives; and paper knives. Files and rasps.

Specimen of an American wedge axe, with solid steel edge, and French polished rosewood handle.

Edge tools, including axes, adzes, augers, mill chisels, carpenters' chisels and gouges, and tools used by builders, joiners, carpenters, shipwrights, coopers, &c.

Polished cast-steel plate for engravers.

Specimens of cast steel in bars.

114 FENNEY, FRED., *Sheffield*—Manufacturer.

Razors of different qualities, including specimens of the best work in carving, grinding, and embossing; new in pattern and design.

Mother-of-pearl show-razor, the blade embossed with scroll ornaments and Sheffield arms; carved and set in silver: the work on the blade was cut by the grindstone.

Specimen, showing the different stages of the manufacture of the blade, all contained in one solid piece of cast-steel, with carved mother-of-pearl handle.

115 COCKER, SAMUEL, & SON, *The Porter Steel Works, Sheffield*—Manufacturers.

Steel suitable for all purposes, from one-sixteenth of an inch and larger. Cast-steel files, of warranted quality, from 1 inch to 40 inches long, for mechanical purposes, watch and clock makers, dentists, &c. A large octagonal file, displaying on its surface sixteen different cuts in general use; also a bar of steel, showing the various

stages of file manufacture from the ingot of steel to the finished file. Circular machine files for sharpening saws. Registered circular file or cutter, for filing plane surfaces, to be attached to machine-power, suitable for filing brass, steel, iron, ivory, &c. Cast-steel wire of every description, from the hair-spring to $1\frac{1}{8}$ -inch diameter, being the largest size ever drawn. Needles, in their various stages of manufacture, from the bar iron, as imported from Sweden, to the finished needle. Sundry specimens of hackles and gills, wool-combers' broaches, edge tools, saws, mill-picks, and chisels. Wire-drawing plates, of a peculiar quality of steel, made only by the exhibitors; and a variety of other articles.

116 HARGREAVES, WILLIAM, & Co., *Sheffield*—Manufacturers.

Coromandel-wood case, lined with crimson silk velvet, containing 12 table-knives, 12 dessert knives, and 1 pair of carvers—all with carved ivory handles, of three various designs, silver ferrules, and highly-polished steel blades.

Table-knives, with ivory handles and silver ferrules, intended for general use.

Table-knives, with fancy wood handles, made for the North American market.

Round-of-beef carvers, with stag-horn handles, silver caps and ferrules, and highly-polished steel blades.

Game carvers, with carved ivory handles, silver ferrules, and similar blades.

Bread knife, with carved ivory-handles, silver ferrule, and highly-polished steel blade.

117 TURNER, THOMAS, & Co., *Suffolk Works, Sheffield*—Manufacturers.

Pair of Albert venison carvers, 6 feet long, with stag antlers.

Round-of-beef slicers, 30 inches long, and trowelled stag-slicers.

Cases of carved ivory table cutlery, also of ivory and pearl silver desserts.

Table cutlery and plated on steel desserts.

A variety of carvers, steels, vegetable-forks, cheese scoops, butchers' knives, palette knives, glaziers' knives, cooks' knives, &c.

The Prince of Wales's sailor's knife, 6 feet long. Gardeners' cutlery and sportsmen's knives.

The Cambrian razor, with a view of the "Suffolk Works," Sheffield, engraved on the ivory haft; and patterns of razors.

Sportsmen's knives in pearl, &c. Various patterns of pocket and penknives.

Stone-saw, used for cutting Bath and other freestone. Circular, hand, and back-saws, &c.

Card of files, such as are in general use.

118 ALGOR, J., 105 *Eldon Street, Sheffield*—Manufacturer.

Knives for shoemakers, clickers, and carriers; shoemakers' and American peg-knives; farriers' and German saddlers' knives; German shoe-knife.

Joiners' and cabinet-makers' blades.

Shoemakers' and carriers' steels.

Saddlers' half-moon knife; Russian shoemakers' knives.

Knives for coopers, painters, and glaziers.

Plumbers' shave hook. Butchers' knives.

Bread knife; Newfoundland fishknives.

Basketmakers' knives and bodkins.

Cooks' knives; palette knives. Butchers' steel.

119 PARKIN & MARSHALL, *Telegraph Works, Sheffield*—Manufacturers.

Table and dessert knives, with carvers, fluted pearl handles, silver ferrules, and polished blades.

Fish-carvers: with the blade in open work ornamented with appropriate emblems, and forks to correspond.

Case of fish-carvers: with shark design.

Pair of melon-carvers, with blade of new design, and fluted pearl handles.

Trays of plated-on-steel desserts, in carved pearl handles with silver ferrules, with the blades chased and ornamented.

Tray of plated desserts, with fluted ivory handles, and silver ferrules.

An assortment of bread knives, with carved handles in ivory and wood.

Large slicers. Trowel hand slicers. A varied assortment of table-knives, carvers, &c.

120 ELLIN, T., & Co., *Sheffield*—Manufacturers.

Shoemakers' knives, with common and rosewood handles, in various sizes.

Glaziers' knives, with cocoa handles. Painters' stopping-knife, with ebony handles. Oyster knives. Farriers' paring knife.

Table knife, with ox-bone handle, and "common point," being the shape used fifty years ago.

The original "Sheffield Whittle." Oyster knife, Billingsgate pattern. Leather-cutter's knife, with wooden handle. Root knife, with cocoa handle.

Carving-knife and fork, self-horn handles. Carving knives; bread, spear and cut-point knives; of various sizes, and handles of different kinds.

Table knives and forks, with mother-of-pearl, ivory, ebony, horn, cocoa, and bone handles.

Steels, with black horn, stag, self, and ivory handles.

Cork and pallet knives. Butchers' steels and knives.

Office knives, with cocoa and ivory handles.

Round-of-beef slicers, with buck, stag, and horn handles.

Carving-knife, 24-inch blade; with strong horn handle.

121 OLIVER, WM., *Sheffield*—Manufacturer.

Case of cutlery, consisting of forty pieces of miniature cutlery, from $\frac{3}{8}$ ths of an inch to 4 inches: the smallest pair will go through an ordinary tobacco-pipe. Silver pistol.

Handle table-knives, as manufactured in 1800, green ivory, round point; handle table-knives, as manufactured in 1750. Venison-carvers, and steel, set in elephants' tusks of miniature size. Jones's patent game-carvers, and steel, set in fawn's feet, mounted in silver.

122 WILKINSON, WILLIAM, & SON, *Grimesthorpe, Sheffield*—Manufacturers.

Sheep and horse shears.

Shears for glovers, thatchers, and weavers.

123 GILBERT BROTHERS, *Sheffield*—Manufacturers.

A variety of superior razors.

124 STEER & WEBSTER, *Castle Hill Works, Sheffield*—Manufacturers.

Gold and silver scissors; surgeons' scissors; and a variety of scissors in general use.

Tailors' shears; cases holding scissors.

Nippers (champagne and nail).

Horticultural tools, such as garden and slide pruning-shears.

125 WOSTENHOLM, G., *Washington Works, Sheffield*—Manufacturer.

A variety of cutlery.

126 WHITELEY, ELIZABETH, 12 *Norwich Street, Sheffield Park*—Manufacturer.

Fine cast-steel scissors.

127 SHEARER, JOHN, *Eldon Street, Sheffield*—Manufacturer.

Shears, polished and bronzed, viz., sheep, of new Australian, Leicester Tomlins, and midland county patterns; horse, Newmarket best; glove, for the trade; and weavers', for the home and American markets.

Weaver's knife and nipper, and single nipper.

[The latter are used by weavers for removing, joining, clipping, and picking out ends, &c., which arise by

breaking or joining of threads in the process of weaving.
—W. C. A.]

Pair of best polished gilt trowel-shank sheep-shears, in miniature; having within the shanks boxes which contain seven articles each, miniatures of trowel-shanks, three pairs, and other kinds of sheep-shears, one pair each of weavers' shears, burling-iron, knife-nipper, and single picker; there are also four articles contained in the backs, miniatures of different patterns of sheep-shears, two in each back; yet the weight of the whole combined does not exceed 17½ ounces.

128 MARPLES, ROBERT, *Sheffield*—Manufacturer.

Centre-bit, 9-inch. Best plated square, 24-inch. Set of forty-two bright brace-bits. Best ebony and horn pricker-pads, with eight tools each. Best mitre-square, 8-inch.

Best London pattern turn screws, ebony, and oval handle, 5 inches each. Gentleman's turn screw. Improved sliding T bevil. Best plated square, 3-inch. Best ebony saw-pad; small boxwood saw-pad.

Best handled saw-set. Best plated spirit-level, 8-inch. Best screw-slide mortice-gauge. Saw and frame. Plated and ebony, ebony circular, London pattern, boxwood, and best screwed and plated spokeshaves.

Improved plated brace, boxwood. Registered self-acting brace, inlaid with pearl. Newly-invented lever-brace, beech-wood, plated. Best shell-gimlet. Patent screw and improved auger gimlets.

129 TAYLOR, HENRY, 105 *Fitzwilliam Street, Sheffield*—
Manufacturer.

Tools for engravers, carvers, and print-cutters. Bur-nishers and scrapers.

Hand-drawn steel. Fancy turning and plasterers' moulding tools. Sail-makers' needles. Sculptors' chisels. Screw-tools. Sticking-knife.

130 HOLMES, C., 90 *Wellington Street, Sheffield*—
Designer and Manufacturer.

Specimens of table knives.
New registered bolster.

131 HARDY, ROBERT E., *Burnhall Street, Sheffield*—
Manufacturer.

Carved bread and plated dessert knives.
Nut-picks and instruments for ladies' work.
Boxes and gentlemen's dressing cases.

132 MARTIN, STEPHEN, 29 *Norfolk Street, Sheffield*—
Manufacturer.

Specimens of various kinds of razors, manufactured from Sheffield steel, in a variety of handles, viz., pearl, tortoiseshell, ivory, bone, horn, hoof, &c., plain and ornamented, from one to sets of seven, on cards, and in various boxes.

133 NEWBOULD & OWEN, *Sheffield*—Manufacturers.

Samples of best steel polished goods, including new and improved scissors for tailors, paper-hangers, barbers, horse-trimmers, pruners, &c.

133A NEWBOULD & BAILDON, *Surrey Works, Sheffield*—
Manufacturers.

Specimens of Roberts' patent table-cutlery. The blades are fastened by means of a dovetail, without cement, and cannot be injured by hot water.

Specimens of registered ivory-handled table-knives. The tangs are made square, and nicely fitted into the handles, without cement, and riveted through at the extremity.

Specimens of table-knives with silver handles.

134 WINKS, BENJAMIN, & SONS, *Sheffield*—
Manufacturers.

Samples of razors and table-knives.
Samples of two and four razors in cases.

135 HAWCROFT, WILLIAM, & SONS, *Sheffield*—
Manufacturers.

Razors, with ivory, pearl, and tortoiseshell handles.
Cases of razors. Articles, illustrative of the process of manufacture.

Large show-razor, embellished with the figures of Peace and Plenty, and the Royal, Sheffield, and Cutlers' Arms.

136 JONES, JOHN, *West Field Terrace, Sheffield*—
Inventor, Patentee, and Manufacturer.

Improved dinner-knife and carvers, with a new form of blade, the whole length of which can be made use of.

Rust-preventive composition, for the preservation of table-knives, fire-irons, fenders, machinery, and military stores.

Specimens of steel goods which were exposed to the open air for six days and nights, the bright parts having been protected with the rust-preventive composition.

137 NICHOLSON, WILLIAM, 17 *Sycamore Street, Sheffield*—
Manufacturer.

Knives with carved profiles of the Royal Family. Single and double-blade penknives. American daggers and spear knives. Wharnclyffe, Norfolk, and Congress knives. American cotton-knives. Improved American hunting-knives, &c.

138 JOURNEYMEN FILE-MAKERS OF SHEFFIELD—
Producers.

Files and rasps of various sorts and sizes, suitable for mechanics, engineers, &c.

Large file, 54 inches long, cut after the form and manner in which files are generally done, to show the various forms of light and shade. Designed and executed by Hiram Younge, of Sheffield.

[File-making is a manufacture which is still in a great measure confined to Sheffield. It is peculiar that hitherto no machine has been constructed capable of producing files which rival those cut by the human hand. Machine-made files have not the "bite" which hand-cut files have: this is accounted for by the peculiar facilities of the human wrist to accommodate itself to the particular angle suitable to produce the proper "cut." "Small files are made out of best cast-steel; those of a larger size from ordinary steel; flat files are forged on an ordinary study. Other forms on bolsters, with the indentature corresponding to the shape required being thereon impressed, a chisel wider than the blank to be cut is used as the only instrument to form the teeth: it is moved by the hand with the greatest nicety. After cutting, and previous to hardening, the file is immersed in some adhesive substance, such as ale-grounds, in which salt has been dissolved: this protects the teeth from the direct action of the fire; it is then immersed perpendicularly in water; cleansed by finishing."—W. C. A.]

139 MAPPIN & BROTHERS, *Sheffield and London*—
Manufacturers.

Sportsman's knife, in pearl, gold-mounted. Exhibited for workmanship. Sportsmen's hunting, angling, and pistol knives. American hunting and dagger knives. Wharnclyffe, Norfolk, Rutland, Richmond, Eglington, and Vernon knives. Ladies' and gentlemen's pen and pocket knives of every variety. Machines for making pens, adapted to every style of writing. Gardeners' pruning, grafting, and budding knives. Paper-folding knives.

Fish carvers, in silver, plated, and electro-gilt, designed after the Italian and Grecian styles of ornament.

Silver, pearl, and ivory handled dessert-knives and forks, with silver and plated blades, chased.

Table cutlery, with handles of silver, ivory, plated, German-silver, self-tip, black tip, bone, stag, porcelain, and wood. Carving and slicing knives and forks.

Knife-sharpening instruments, cheese-scoops, palette-knives, cooks' and butter knives.

Carved-wood bread platters, with suitable designs and mottoes.

Bread knives, with carved and fluted ivory and wood handles.

Specimens of the registered lancet-edge razor: exhibited for keen and durable edge. Specimens of the army and navy razor.

Old English, concave, guard, and Indian steel razors, and seven-day razors in cases.

Hair, nail, and cutting-out scissors, paper-lamp, pruning, and horse scissors; also, scissors for drapers, tailors, &c. Ladies' fancy-work scissors.

140 HOOLE, ROBSON, & HOOLE, *Green Lane Works, Sheffield*—Manufacturers.

Bright register-stoves, with burnished steel and or-molu mouldings; the same, fitted with a porcelain and bright hearth-plate, forming a fender.

Cast-iron register-stove and mantelpiece, with or-molu mountings; the iron left in its natural state, and secured from rust.

Bright register-stove, with or-molu, hollow, and bronzed ornaments.

Burnished steel register-stove, with figures and or-molu mountings. Register-stove in cast-iron; the same stoves according to Stephens' patent.

Burnished steel register stove, with or-molu spandrils and mouldings.

Bright register-stove and chimney-piece, with or-molu mountings and cast-iron spandrils, as taken from the sand, but secured from rust.

Bright register-stove, with stamped burnished steel ornaments. Register stoves with porcelain cheeks.

Cast-iron register-stove, invented and registered by John Finlay, Buchanan Street, Glasgow, for curing smoky chimneys, and economising the consumption of fuel.

Black register-stove in cast-iron. Ornamental hot-air pedestal stove.

Burnished steel fenders, with metal and or-molu mountings. Bronzed fender, with steel mountings. Dead or sprung steel fenders, with stamped burnished steel ornaments. Bronzed, black, and cast-iron fenders.

Specimens of ornamental castings.

142 CLAYTON, GEORGE, *5 Love Street, Sheffield*—Manufacturer.

Specimens of table cutlery in black tip, self-tip, white bone, German silver, ivory, and plated on steel in ivory and pearl handles.

A large bread-knife.

143 BAGSHAW, WILLIAM, *37 Spring Street, Sheffield*—Manufacturer.

Assortment of fine penknives.

144 BARGE, HENRY, *Low Street, Sheffield*—Manufacturer.

Collection of pocket-knives, of various styles, with ornamental handles in ivory, pearl, stag, &c.

American hunting-knives, &c.

145 BRIGGS, S., *186 Solly Street, Sheffield*—Manufacturer.

Shoemakers' awls and tacks, for basket, mattress, and staymakers; sacking and saddlers' needles, &c.

Bookbinders' or printers' bodkins.

Joiners' improved brad-awls and punches; cabinet-makers' improved awls.

Centre and other punches. Shoemakers' pegging awls, feathered; birdcage-makers' and various other awls.

Packing-needles, polished.

Gentlemen's portable hand-pad, complete with bits.

Shoemakers' awl-blades, blued; improved, or French pattern; French, or 4-square; Liverpool, or flat points; portable, and in self-tip handle, complete with awls.

Carriers' steels, handled.

Nut-picker, ivory-handled, round rim, and self-tip, plain.

American socket-vice, improved for pegged boots and shoes.

146 HARDY, T., *9 Moore Street, Sheffield*—Manufacturer.

Stilettoes, crochet-needles, button hooks, nail files, corkscrews, tweezers, boot hooks, &c., in pearl, ivory, tortoiseshell, stag, polished steel handles, for fitting up ladies' work-boxes, companions, gentlemen's dressing cases, &c.

147 SELLERS, JOHN, *Sheffield*—Manufacturer.

Razors, and cases of razors. Fine penknives, Wharncliffe and Congress knives.

Pocket and sportsmen's knives, including "The Harewood knife," "Norfolk knife," "Rutland knife," "Walton fishing-knife," "Wilkinson knife," &c.

Surgeons' cutting instruments. Tools for the use of engravers on steel and copper. Pen-making machines.

Steel plate for the use of engravers, machine-ruled, by C. Mottram, Esq., of London. The sky tint upon this plate is perhaps the most severe test to which a steel plate can be subjected; the surface is free from spots or seams; and it is exhibited to show that steel is well adapted to the wants of the etcher and engraver.

Proof impression from the plate on India paper.

[An entire change in engraving has taken place by the substitution of steel for copper plates. An engraving made upon copper is speedily rendered useless by the process of inking, and the friction necessary to remove the superfluous ink. The rubbing with whitening to clean the face of the plate, wears away the surface, and renders it valueless after a few thousand impressions. This is not the case with a steel plate; an instance is on record where 500,000 copies were printed from one plate.

The Queen's head on the postage stamp has been only once engraved. It had, in 1842, been multiplied 6,000 times, that is to say, the original produced 6,000 plates, which printed all the postage stamps of the above kind which had been used since the introduction of Rowland Hill's measure up to the period stated.

The multiplication of a steel plate is a feature of some importance: a plate is engraved and hardened; from this an impression is taken upon a softened steel roller; this steel roller is then hardened, and softened steel plates being passed under it, an impression is imparted to them; they are in turn hardened, and are equal to the original as to their impressions. This method is adopted in bank-note engraving; and the postage-stamp plates are produced by the same means.—W. C. A.]

149 NOWILL, JOHN, & SONS, *Sheffield*—Manufacturers.

Assortment of knives for the Levant trade.

Assortment of cutlery, comprising ladies' and gentlemen's pen and pocket knives.

A similar assortment mounted in gold and silver.

Paper folding-knives. Sporting-knives.

Indian hunting-knives. Silver fruit-knives.

Case of carved pearl plated dessert knives and forks.

Nail knives and nail files. Fittings for gentlemen's dressing-cases, ladies' companions, &c.

German smoking knives. Pen-machine knives. Pencil-knives.

Glaziers' ivory diamond-holders, registered by W. Harris, January, 1845.

Solid ivory handle, containing pencil and penholder, with silver cigar-holder, toothpick, and nail-cleaner, erasing-blade and nail-file, and four pen-blades, put together without a rivet being visible.

Solid ivory handle pen-knife, with slide pencil and penholder.

Coromandel-wood cases of ladies' and gentlemen's toilet cutlery.

Case containing silver dessert knife, fork, and spoon.

Cases containing two, three, four, and seven razors each.

Assortment of razors in ivory, pearl, and tortoiseshell handles.

Pair of razors in pearl handles, framed with silver, and the cutlers' arms carved in relief on the handles.

150 ARMITAGE, M. & H., *Mouschole Forge, near Sheffield*—Manufacturers.

Engineers', coachsmiths', and boilermakers' anvils. Double piked smiths' anvil. Double arched jobbing anvil. Sawsmiths' anvil. Pattern anvils.

Set of grinders' screws and plates. Smiths' vice. Pattern smiths' vice. Sawsmiths' vice.

Large water tue-iron. Pattern water tue-iron.

Sledge hammer. Smiths' hand hammer. Cross and straight pealed hand hammers.

Engineers' and millwrights' hammers, different kinds.

Joiners' claw hammer. Masons' tools of different kinds.

151 ELLIOT, J., *Townhead Street, Sheffield*—Manufacturer.

Pattern razors, manufactured of the best steel, exhibited for temper, design, and workmanship.

Frame-back razor, ground exceedingly thin, and cannot require to be again ground, thus retaining a fine and durable edge, and increasing greatly the ease of shaving. The gold, silver, steel, German-silver, or brass backs, form an elegant contrast to the blade, and enhance the beauty of appearance as well as afford more opportunity for originality of design and skill in execution.

Pearl-tang razor, constructed to prevent rust.

Razors with hollow-ground blades are especially designed for barbers' use. These do not require to be again ground, on account of their extreme thinness.

[Two workmen are always engaged in razor-making. The rod of steel of which they are made is about half an inch in breadth, and of sufficient thickness to form the back. The stake upon which they are forged is rounded on both sides of the top, which is instrumental in thinning the edge, and much facilitates the operation of grinding. The blades are then hardened and tempered in the ordinary way, with the exception, that they are placed on their back on an iron plate, and the moment they assume a straw colour of a deep shade they are removed.

The grinding follows, on a stone revolving in water; then glazing on a wooden disc. The fine polish is given by a wooden wheel, having its circumference covered with buff leather, which is covered with crocus. The ornamentation of the blade, by etching with acid, and gilding, if such is required, is the last process.—W. C. A.]

Scales with registering dial.

154 WEBSTER, GEORGE, *Hovard Street, Sheffield*—Manufacturer.

Razors exhibited for quality and workmanship. Registered double-edged razor.

155 LEDGER, C., *83 Carver Street, Sheffield*—Inventor and Manufacturer.

Various razors, including glazed and polished tanged; curiosity razor, shuts backwards, and when shut the blade is entirely encased; black and ivory-handled portables;

black-handled full sized concave and "long cut," ivory-handled concave "flat tang" and "long cut," ivory-handled tastefully ground fancy concave and "long cut."

Table-knives "bolster" balanced: black tip ivory and silver plated handled "half Waterloo," with moulded fluted new pattern "bolster" balanced; ivory-handled "flat top hollow" table-knives; "oval bolster" and "Waterloo bolster" balanced; self-tip and ivory-handled, with "half Waterloo" double thread hollow "moulded" new pattern "bolster;" black tip-handled, with eight square four threaded new pattern "bolster" balanced; self-tip and ivory-handled, with half Waterloo flat top fluted new pattern bolster; silver-plated dessert knives, with registered emblematical design handle, and chased blades; pearl-handled plated dessert knife, with emblematical ferrule.

[By "balanced" is meant the handle counter-balancing the blade, thereby lifting it up from the table.—W. C. A.]

156 ELLIS, I., *188 West Street, Glossop Road, Sheffield*—Manufacturer.

Card of razors, manufactured from the best steel.

Table knives; butchers', pallet, putty, and stopping knives.

157 DEAKIN, G., *83 Arundel Street, Sheffield*—Inventor and Manufacturer.

Scissors of various patterns, with bent blades and handles, intended for clipping horses, with gutta percha covering the bows, whereby they are not liable to gall; scissors with bows covered with leather; and without covering.

Horse-clipping and trimming scissors, having the bows covered with an elastic composition, to save the hand. Scissors with the bows and handles covered with the elastic composition.

Elastic metallic combs, of different patterns and kinds, used in clipping and trimming horses.

Lamps for singeing horses, after clipping.

Tailors' shears, possessing power in cutting, ease for the hand, and durability. Forged or wrought solid.

158 SLAGG, HERBERT WEST, *Ford, near Chesterfield, Derbyshire*—Designer and Manufacturer.

Reaping hooks, sickles, and scythes for cutting corn, grass, &c.—

1. For the neighbourhood of London, Surrey, Hampshire, Dorchester, Berks, and Bucks. 2. Wales and Salop. 3. Staffordshire and Cheshire. 4. Isle of Wight. 5. North of England. 6. Sussex, Surrey, and the United States. 7. Berks, Bucks, Kent, Surrey, Hants, and Canada. 8. Lincolnshire, Norfolk, and Cambridgeshire. 9. Indies and America, for cutting indigo. 10. Cornwall, Guernsey, and Jersey. 11. Norfolk, Lincolnshire, and Cambridgeshire. 12. Scotland. 13. Cutting garden-hedges. 14. Sussex and Surrey. 15. Yorkshire and North of England. 16. Indies. 17. Cutting beans. 18. Thatcher's knife. 19. Spain. 20. Yorkshire and North of England. 21. Leicestershire, Northamptonshire, Worcestershire, Notts, Berks, and Bucks. 22. Staffordshire, Worcestershire, Warwickshire, and Canada. 23. Ireland, South. 24. Ireland, North. 25. Hertfordshire, Cambridgeshire, Cheshire, and Beds. 26. Beds and Hertfordshire. 27. Australia. 28. Kent. 29. Poland. 30. Russia. 31. Holland and the Cape of Good Hope. 32. United States. 33. Sussex. 34. Ireland. 35. Cutting and cleaning hedges. 36. Patent scythe. 37. Crown, or hammered.

The novelty is in the formation, easy and improved handles, suitable grinding, and the general completion. The reaping and bagging hooks are made of cast-steel.

159 UNWIN & ROGERS, *Rockingham Works, 124 Rockingham St., Sheffield*—Manufacturers.

Bowie knives, American and Indian hunting knives. Lock, sneck, dagger, or dirk knives, suitable for the Continent and South America. Pistol knives, in a variety of handles, with single and double barrels.

Pencil knives, of registered patterns, and various other kinds, with pearl, tortoise-shell, and other handles. Cigar knives, of registered and other patterns. Sportsman's knives in great variety. Desk knives, with folders and erasing blades. Comb knives, with pencil, six-inch rule, and other articles.

Knife, fork, and spoon knives, in cases and rolls. Garden knives, with vine, pruners, saws, budding blades, &c.

Pen-machine knives of all kinds. Scissor knives of various sorts. Fly-open knives, with and without guards. Sailors' knives, with copper swivels. Pen and pocket knives.

Razors of fine quality in mother-of-pearl, tortoise-shell, ivory, and other handles. Lancets and farriers' knives.

Fleams for bleeding cattle; various blades in brass and other handles.

Nail files, button hooks, and various fancy articles, for ladies' companions and gentlemen's dressing-cases.

160 MARRIOTT & ATKINSON, *Fitzalan Works, Sheffield*—Manufacturers.

1 to 65. Various files and rasps, of different sizes, and for a variety of purposes.

66 and 67. Steel moulds for files.

68 Forged blank for file.

69 Forged blank for file, lighted.

70 Groomed blank for file.

71 Cut file.

72 Finished file.

73 Bar iron.

74 Bar or blister steel.

75 Cast-steel ingot.

76 Rolled bar steel, for coach springs.

77 Double shear steel.

78 Oval cast steel, for chisels.

79 Round cast steel for spindles.

80 Square cast steel for tools.

Model springs, viz. :—

81 Locomotive engine.

82 Dray.

83 Railway waggon.

84 Railway first-class carriage.

85 Elliptic, for carriage.

86 Gig or light cart.

87 Model file, 20 inches

long, divided into compartments of the various descriptions of teeth required for files and rasps. Supported by two pedestals on a plateau of burnished cast steel, containing a view of Fitzalan Works.

160A FEARNCOMBE, H., *Wolverhampton*—Manufacturer.

Portable wash-stands, grained mahogany, painted, veined imitation Sienna marble. Coal vases, flat top, painted hawking-party, nautilus shell, &c. Oval dish-covers. Tea-trays, painted, and Elizabethan. Copper bronze kettles, stands, and lamp. Spittoons. Ewers and basins. Revolving and perpetual almanacks. Date indicator. Hot-water jug. Tea caddies. Coffee-pot, boiler, and filter. Tureen. Hot-water dish and cover. Dressing-case. Some of these articles are registered.

162 MARSH BROTHERS & Co., *Sheffield*—Manufacturers.

Specimens of steel used for tools, cutlery, &c. Table and small cutlery. Butchers' knives; razors; edge tools; files; scythes; hay-knife; straw-knife. Spring for railway trucks, waggons, &c.

163 BROOKSBANK, A., *Malinda Works, Sheffield*—Manufacturer.

Files and rasps of different sizes, adapted for the use of engineers, joiners, &c.; manufactured from the best cast-steel.

164 WORRALL, HALLAM, & Co., *Sheffield*—Manufacturers.

Hackles, circular gills, and other gills for flax-dressing. Samples of cast-steel wire in coils and lengths. Spiral springs for balances and machinery. Brass spurs for self-acting templets. Specimens of needles in different stages of manufactures. Samples of hackle and gill pins. Set of brush-makers' engine-combs. Cast-steel broaches for wool-combing.

165 COUSINS, J., & Sons, *Garden Street, Sheffield*—Manufacturers.

Paper scissors and bankers' scissors; tailors' scissors; horse-trimming scissors.

Ladies' cutting-out and fancy scissors.

Grape-scissors and flower-gatherers to hold.

Gentlemen's budding-scissors and flower-gatherers.

Gentlemen's nail-scissors; left-handed scissors.

Gardeners' budding-scissors to hold.

166 HUTTON, JOSEPH, *Ridgeway, Sheffield*—Manufacturer.

Two bars of iron and one of cast-steel. Two and a half bars of iron, and half bars of cast-steel, welded together under a tilt (water or steam power hammer), and to be used for the manufacture of scythes and edge-tools; also for the more effectual prevention of housebreaking, the steel, when tempered in water, presenting a powerful resistance, while its elasticity renders it applicable to the lining of curved window-shutters, doors, &c.

Berkshire hooks, for reaping, to be used in the manner of a Hainault scythe.

Riveted scythe, composed of strips of cast-steel between two layers of iron. Riveted Berkshire hooks, formed in same manner, both water hardened.

Pair of cart axles, with revolving spherical bushes, upon a principle which is applicable to railway carriages, heavy machinery purposes, &c. Spheres for revolving spherical axles and bushes; reduces friction, &c.

Sheep-shears, with cast-steel edges, which will not chafe each other.

Sickle, adze, joiner's bench axe, Sussex woodman's bill, firmer-chisels, socket-chisels, and double plane-irons; all with cast-steel edges.

167 FLATHER, DAVID, *Solly Works, Sheffield*—Manufacturer.

Joiners' tools, consisting of braces, bits, squares, bevels, gouges, spirit-levels, spokeshaves, turnscraws, augers, gimblets, saw-pad, saw-set, brad-awl, pad, and skates.

168 MACHON, JOHN, *Sheffield*—Manufacturer.

A variety of scissors and slide pruning shears.

169 MARSDEN, BROTHERS, & SILVERWOOD (late FENTON & MARSDENS), *Bridge Street Works, Sheffield*—Manufacturers.

The "Royal Albert" skate.

Selection of skates, assorted in various patterns.

Tools for joiners, carpenters, and cabinet-makers.

Braces, with registered brace-head, constructed so as to prevent its working off.

The registered mortice-gauge, having the tube or barrel moved at either end by means of a turn-screw, which sets the head and the cutters firm in position.

Screw and shell augers, of various patterns and sizes.

A general selection of botanical and horticultural tools, suited for professional and amateur gardening.

170 JOWETT, J., *Arundel Lane, Sheffield*—Manufacturer.

Edge tools and sheep shears.

Horse, rag, and weavers' shears.

171 BROOKES, JOHN, *Dorset Street, Spring Lane, Sheffield*—Manufacturer.

Articles suitable for ladies' work-boxes and gentlemen's dressing-cases, made in steel, ivory, and pearl; button hooks, nail files, tweezers, corkscrews, stiletos, &c.

172 HALL, T. H., *Leecroft, Sheffield*—Manufacturer.

A variety of tops, saws, screws, &c.

173 WILLOUGHBY, T., *Sheffield*—Manufacturer.
Secret dial penknives.

174 TURNER, HARRIET & WILLIAM, *Bridge St., Sheffield*—Manufacturers.

Registered fire-irons, viz.:—

Octagon heads, and square arras bows and shanks.

Improved leaf bow diamond cut shanks, rich or-molu heads, and new vase-pan.

Twisted diamond cut shanks, bows, and heads.

Octagon heads and bows, with hexagon shanks and poker, of new form.

Or-molu heads, and plain shanks.

Octagon fluted shanks, and original heads, bows, and shanks, to supersede the old joint made inside of the bow.

Short leaf bows, with octagon heads, bows, and shanks, with new joint and modern heads.

Or-molu and steel head. Modern octagon shanks.

Plain twisted shanks, octagon steel heads.

Plain octagon heads, bows, and shanks. Plain bedroom.

Octagon heads and plain shanks. Steel standards.

Registered Cyma-recta, or bent fire-irons.

175 WILKINSON, THOMAS & GEORGE, *17 New Church Street, Sheffield*—Manufacturers.

Duplicate specimen of scissors, manufactured for the Queen, with the ornamental scroll-work, royal arms, Victoria, &c., filed out of solid steel. Six dozen files were required to cut out the work.

Heraldic dressing-case scissors, with the arms of H.R.H. Prince Albert, of the Duke of Norfolk, and of the Duke of Devonshire.

Ladies' scissors, with scroll-work handles, and electro-gilt medallion of the Queen. Ladies' steel scroll-work scissors, forming the letter V, filed out of solid steel. Ladies' scissors, lily-of-the-valley pattern, with steel blades, and electro-gold and silver handles. Ladies' scissors, vine pattern, with steel blades, and electro-gold handles.—Provisionally registered.

Nail-scissors, with medallion of H.R.H. Prince Albert.

Dagger and paper scissors, Elizabethan style, with steel blades, etched scroll-work, and electro-gold handles. Large cutting-out scissors, design—rose, shamrock, and thistle, filed from solid steel.

Scissors, 23 inches long, forged from ingot of steel, with etching on blades of the Exhibition Building and scroll-work.

Patterns of scissors, with handles, Gothic, German, and other styles, also flowers, snakes, birds, dolphins, filed steel scroll-work, &c. Patterns of scissors, of different sizes. Ladies' fine work, cutting-out, lace, nail, button-hole, and dressing-case scissors. Miniature scissors, six pairs, weight $\frac{1}{4}$ grain, and in sizes from $\frac{1}{16}$ th to 2 inches long. Improved double-spring nail scissors. Hair-cutting, nail, and drapers' scissors, and fly trimmers.

Bankers', paper, and paper-hangers' scissors. Tendon-separators, and surgeons' scissors. Improved dressmakers', calenderers' or packers' and fustian scissors. Scissors and steel combs, for trimming horses. Good steel forged scissors. Tailors' scissors and shears, of different sizes and patterns.

Improved tailors' shears, with electro-gilt, silver, German silver, and brass handles. The combination of brass, &c., with steel in the manufacture of tailors' shears is the invention of the exhibitors; it allows the handles to be moulded exactly to fit the hand, gives great strength in cutting, and is made at less cost.

Regulating spring-screw, invented by the exhibitors; it resists the pressure caused by cutting strong substances, and prevent shears or scissors from working loose. Lever-spring scissors, intended to give uniform pressure upon the edges, and prevent friction. Scissors, showing various stages of manufacture. Pruning shears and scissors, vine-scissors, flower and grape gatherers, shears for cutting gold, silver, copper, tin, &c.

176 BLOOMER & PHILLIPS, *Albert Works, Sheffield*—Manufacturers.

Various brace-bits. Kingswood brace, with new ever thumb-bit. The simplicity of the spring prevents it from being injured in any part.

Ebony brace, with lever thumb-bit. Chisels and gouges. Bright brace screw-bits. Double CS plane iron. CS gentleman's drawing-knife. Squares. Best square, 30 inches. Two each shell and screw. Improved sliding bevil, 6 inches. Spirit levels. Ebony and kingswood spokeshaves. Ebony plated spokeshave. PloUGH bit.

177 WRIGHT, JOHN, *New George Street, Sheffield*—Manufacturer and Inventor.

Ladies' and gentlemen's skates, with improved swaged irons and toe leather.

Improved truss, with rack pad, to obtain any pressure required.

Two-handled horse-scraper, which may be used instead of a curry-comb.

Cast-steel shoe-lift. Specimens of horse trimmings, cast-steel. Ladies' steel busks, made by registered apparatus.

Crochet-spikes, made to be fitted on any shoe, and removed to suit the tread of the wearer.

Combs made of cast-steel, for graining oak, &c.

178 UNWIN, W., *Sheffield*—Manufacturer.

Knife with various blades, scissors, cork-screws, &c.

179 MORRISON & PARKER, *Rockinghamshire Street, Sheffield*—Manufacturers.

Carpenters' braces, with and without complete set of bits.

Square, spirit level, bevel, spokeshaves (assorted kinds), gauges, saw-pads, gimblets, augers, and turnscrews.

180 MAPPINS, J., *Sheffield*—Manufacturer.

Engraved razor and knife handles.

181 HOWARTH, JAS., *Sheffield*—Manufacturer.

Tools for engravers and print-cutters, comprising gravers, burnishes, and scrapers.

Mariners' compass, needles, and gunsmiths' stocking tools. Turning and carving tools. Edge tools—light, comprising chisels and gouges. Edge tools—heavy, comprising adzes, axes, and garden tools.

Tool chests for botanists and tourists, containing rake, hoe, two-prong garden fork, three-prong fork, garden-trowel, pruning-chisel, weed-hook, Dutch hoe, spud-hammer and hatchet, pruning-saw, chisel, pick and spike, with long and short handles.

182 BROWN, HENRY, & SONS, *Western Works, Sheffield*—Manufacturers.

Braces and bits. Improved plated brace, with lignum vitæ head. Iron brace, with brass head. Small fancy brace, with ivory head.

Patent anti-friction brace, with ebony stock, ivory head, with bits complete. The improvements are, that the spindle works upon a hard steel centre, instead of a collar, which reduces the friction, and the head is secured to the neck by a nut screwed into the socket-piece, to prevent the head coming off, and produce the steady working of the brace.

Squares:—Plated and ebony, with spirit-level.

Bevil:—Improved slide; ebony.

Gauges:—Ebony, improved rack gauge, screw slide mortice; and cutting gauge.

Turnscrews:—Handled, bright, London, round blade, and Moon's pattern.

Spokeshaves:—Boxwood, beech, pearl, plated, ebony. Pearl plated screw-irons.

Saw-pads:—Ebony and boxwood, improved. Saw-set, with handle.

Spirit-levels:—Ebony, plated, and Scotch patterns.

Saw-frame:—Boxwood, inlaid with ebony.

Pricker-pads:—Ebony and ivory, with tools, gimlets, shell, and patent twist.

Augurs:—Common screw; bright shell; and Scotch screws. Skates:—Ebony, inlaid.

183 SKIDMORE & Co., *Enema Works, Sheffield*—Manufacturers.

A variety of surgical instruments.

184 DONCASTER, D., *Sheffield*—Manufacturer.

Patterns of steel.

185 PLIMSOLL, SAMUEL, *Sheffield*—Inventor.

Improved warming and ventilating apparatus, which can be forced by means of a wheel-fan, adapted, by means of a white enamel upon the exterior surface of the hot-air piping, casing, &c., to retain and conduct heat.

Improved runner, wheel, and cap for a pocket-umbrella; improved rib and stretcher for the same. A pocket-umbrella to attach to a walking-stick, or any other handle.

Improved surface-file handles. Concave and convex surface-files; exterior and interior angle files. Moulding-file.

186 DEANE, DRAY, & DEANE, *London Bridge*—

Inventors and Proprietors.

Fire-lump stoves (Leslie's patent, and the exhibitor's registration). These stoves are represented in the following engravings:—

No. 1.

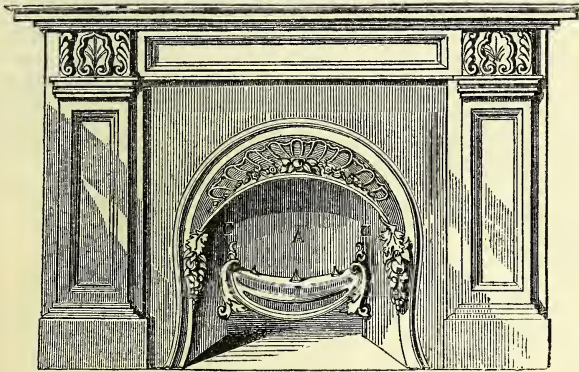

Nos. 1 and 2 are front views of this improved stove. The bottom, sides, and back are formed of a single fire-lump A. The front, facings, and other parts, are of iron. The curved bottom of the fire-lump projects in front to within half an inch of the grate bar a; and it rests upon a cross bearing, B, which is turned up behind as in fig. 2, in order that the latter may afford resistance to any thrust, from in front, against the fire-lump.

C C are two binding slips which fit into recesses of the sides c c of the fire-lump, and in the plan fig. 3; and come flush in front with the metal cheeks b b. D D are angle tie-pieces attached to the cheeks behind, and fitted to the sides of the fire-lump. E E are screws which are passed through the binding slips C C, and angle tie pieces D D to bind the whole together. By undoing these screws, and removing the slips C C, the fire-lump can be entirely withdrawn, without disturbing the other parts of the stove.

No. 2.

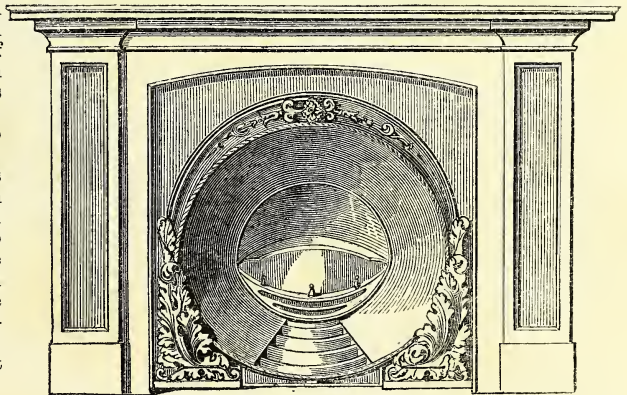

No. 3.

Fig 1

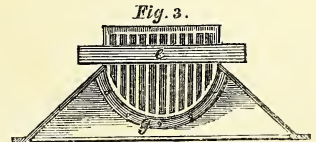
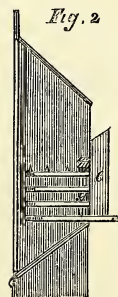
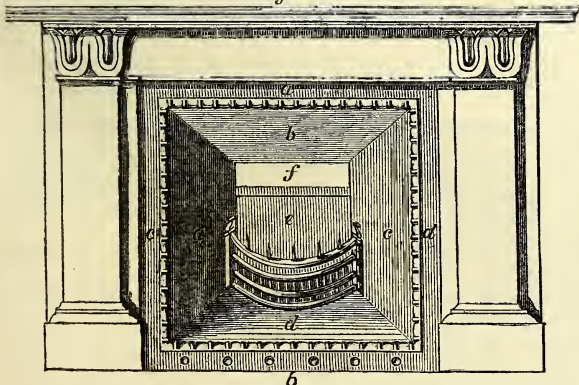

The utility of this stove consists in the grate or receptacle for the fire being entirely in front of the reflecting cheeks, and the additional reflector below the grate, increasing the reflecting surface.

Fig. 1, is a front view of the stove. Fig. 2, a vertical section on the line a b. Fig. 3, a transverse section on the line c d.

The back of the fire-grate, g, formed by the introduction of a fire-

lump e, which, with the whole of the brick-work for setting may be introduced through the opening formed by the plates a b c d. A portion of this opening, f, is left vacant for the passage of the smoke.

Yacht stove, with copper boiler and steaming apparatus. Small yacht stove, without copper boiler.

Model improved cooking stove, with steam-closet, three steam kettles, bath, &c., all heated with one fire.

Electro-plated goods:—Sets complete, consisting of tea, coffee, water-pot, sugar, and cream,—teas extra; liquor-frame, cruet-frames, flower-stands, toast-racks, salts, waiters, and candlesticks.

Britannia-metal goods:—Dish-covers, manufactured by a new mechanical process, with strong metallic wires in the edges, equal to silver in appearance and durability; exhibited for cheapness; teapots, salt, mustard, pepper, soup-ladle; gravy, table, dessert, and tea spoons; also jugs, swing-kettle, dish-covers, cruet-frame, candlesticks, and coffee-pot.

Cast-steel, circular, and swaged saws:—London spring hand-saw, polished blade, with mahogany, zebra, London pattern, and country pattern handles.

London spring polished blade, with zebra-wood handle.

Improved pruning-bill, with polished blade, and kings-wood handle.

187 WARBURTON, CHARLES, 60 *Eyre Lane, Sheffield*—Manufacturer.

Bright Scotch screw-anger with eye, 6-inch, weighing nearly 1 cwt., and in length 7 feet; considered the largest of the kind ever manufactured.

A variety of Scotch screws, twisted, and other augers, of different sizes, including a bright four-twist auger with eye $\frac{1}{4}$ inch, exhibited as a curiosity on account of its being a four-twist.

Improved shell-auger, $\frac{3}{4}$ -inch: a recent invention.

187A JOWITT & BATTIE, THOMAS & JOHN, *Saville Works, Sheffield*—Manufacturers.

Specimens of forged, tilted, rolled, and hand-drawn, cast, shear, and spring steel.

Complete set of engineers' and machine-makers' cast-steel files.

188 HIGGINBOTHAM, G. & W., *Sheffield*—Manufacturers.

An assortment of scissors, ornamented and mounted with gold and other metals, suitable for dressing cases, writing desks, &c.

Pair of fine scissors, made of refined steel, and hardened and tempered by a process not yet made public, which produces a durable edge, and a brilliant polish.

Razors, in ivory, tortoiseshell, and mother-of-pearl handles, and gold and silver mountings, with blades of similar temper, made of refined steel, and highly finished.

190 TURTON, THOMAS, & SONS, *Sheffield*—Manufacturers.

Steel, commencing with Swedish bar iron.

Steel converted into blister steel of various temper.

Steel rolled for the manufacture of springs.

Refined cast-steel in the ingot.

Steel "tilted" into flats and squares for turning-tools, drilling and planing tools, millbills, dies, and every description of mechanics' tools, axes, &c.

Steel tilted oval and octagon, for cold chisels, &c.

Steel tilted under the hammer in swages, especially for taps and other articles used in machinery.

Steel tilted and rolled for the manufacture of files, edge-tools, chisels and gouges, plane-irons, circular and other saws, cutlery, and all articles manufactured from steel.

[Steel may be regarded as a carburet of iron; it is usually manufactured by the process of cementation. The *cement*, as it is called, consists of the charcoal of hard wood—sometimes soft is employed—mixed with a small quantity of ashes and some salt. The bottom of the trough of the *cementing* furnace being covered with this mixture, bars of steel are placed upon it; these are again covered with the carbonaceous compound, and so on until the trough is filled. The whole is closed, and

the fire urged until all acquires a temperature of about 100° Wedgwood; and this is steadily maintained for some days, the time varying, under different conditions, from four days to ten. In these furnaces, 12 tons of bar iron may at each charge be converted into steel. Blistered steel is so called from the air-bubbles which cover its surface, which blisters appear to result from the formation of carbonic oxide in the process of cementation.

The operation of *tilting* is performed by beating the steel under tilt-hammers until it is rendered of a very uniform structure. The tilt-hammers usually weigh about 200 cwt.—R. H.]

Files for engineers, machine-makers, millwrights, saw-mills, cabinet-makers, joiners, builders, agriculturists, &c.

Edge-tools, consisting of firmer chisels and gouges, turning-chisels and gouges, parcing-chisels and gouges, millwrights' chisels and gouges, socket-chisels, mortice-chisels, single plum-irons, cut plum-irons, double plum-irons, drawing-knives, coopers' tools of every description, augers, English, American, Brazil, and ship axes; English, American, Brazil, and ship adzes; knives for carriers, tanners, and skimmers, and various other articles comprised under the name of edge-tools.

Springs of various sorts for locomotive engines, railway passenger carriages, waggons, &c. Saws. Cutlery.

191 IBBOTSON BROTHERS & Co., *Sheffield*—Manufacturers.

Collection of polished cast-steel circular saws.

Cast-steel mill saws; cross-cut saws; pit saws; frame saws; mill saw webs; stone saws; and Russian cross-cut and frame saws. Segment of a circular veneering saw.

Grafting, hand, panel, ripping, and steam saws, of different degrees of polish; with ebony, mahogany, rose, lignum-vitæ, maple, zebra, tulip, box, satin, red, and beach-wood handles, plain and variously ornamented.

Cast-steel cheap hand saws.

Back saws, with iron, burnished steel, blued and brass backs; with handles of hard wood.

Lock saws, with beech and lignum-vitæ handles, and with rosewood and mahogany pistol handles.

Pruning saws; billet webs; breaking-rut webs; turning, metal, and fret saws; and butchers' webs.

Cast-steel patent scythes. Cast-steel scythe rolled up, to show its elasticity.

Flat files—ruff, bastard, second-cut, smooth, dead-smooth, and double dead-smooth. Hand files, assorted cuts and sizes.

Three-square saw files, mill saw files, feather-edge, cross, ruffle, rounding-off, entering, four-square, cotler, frame and gulleting, cabinet-makers' files and rasps.

Knife files, rubbers, flat-shoe rasps, half-round, double bevelled, and tongued horse rasps.

Ivory, tip, and stag table-knives and forks; dessert-knives and forks; guard, slicer, trowel, and venison carvers.

American hunting-knives. Table-knife sharpeners. Tilted best cast-steel.

192 BUTCHER, WILLIAM & SAMUEL, *Sheffield*—Manufacturers.

Specimen razor, with handle formed of one piece of ivory, ornamented with engravings of the various manufacturing of the exhibitors; the etchings on the blade represent the "Great Exhibition" building, accompanied with an allegorical illustration of "Commerce and her attributes."

Various descriptions of razors, edge tools and files, and saws.

Samples of cast-steel, round, four-square, and hexagon, in assorted sizes.

193 BLAKE & PARKIN, *Meadow Works, Sheffield*—Manufacturers.

Improved cast-steel files and rasps, for engineers, machinists, &c. Improved cast-steel saws. Pair small

vices. Hammer-heads, and several pieces of patent tempered steel. Machine paper-cutting knife. Envelope cutters. Paper-makers' beating-plates and circular cutter.

Cloth manufacturers' spiral cutting edges on a cylinder; and loose cutters of different shapes. Tobacco cutting knife. Machine cutters for planing wood. Moulding and grooving irons, for wood work. Logwood cutting-knife and rasp. Corkcutters', tanners', and curriers' knives. Sheet cast-steel, polished for paintings. Mill-chisel with handle. Small patterns of springs, for railway uses.

194 GIBBINS & SONS, *Sheffield*—Manufacturers.

A pair of scissors, 19 inches long, representing the arms of England, France, and America, with the motto, "unity and peace," worked with small files and drills, round a portion of the bows in cipher letters. Exhibited for design and workmanship.

An assortment of pruning-scissors. A pair of scissors in the first process of manufacture. An assortment of nail-nippers. Champagne nippers or openers, various patterns.

An assortment of pruning-shears. Avernancaters.

Garden hedge-cuttingshears. Fruit and grape-gatherers.

Garden-fork, reel and line. Ladies' garden-fork.

Sets of scissors, of assorted sizes, and for various purposes.

195 WILSON, JOHN, & SON, *Sycamore Street, Sheffield*—Manufacturers.

Samples of shoemakers' knives. Butchers' and bread knives. Cooks' and curriers' knives. Farriers' and glaziers' knives. Palette knives and weavers' knives. Butchers' steels, &c. Corporate mark, four peppercorns and a diamond thus—

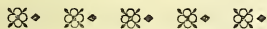

196 WARD & PAYNE, *Sheffield*—Manufacturers.

Edge-tools in every variety, comprising tools used by carpenters, joiners, shipwrights, millwrights, coach and cabinet makers, &c., such as cast steel firmer-chisels, gouges, plane-irons, socket-chisels, drawing-knives, block-makers' chisels and gouges, German parting-tools, coopers' tools, plasterers' moulding tools, shell and screw augers, trowels, machine plane-irons and moulding-irons, Brazil, Canada, London, coachmakers' and long falling axes, hatchets, choppers, hedging-bills, &c.

Curriers', tanners', skimmers', saddlers', mincing, and bookbinders' knives; turning-chisels and gouges; fancy turning-tools for iron, wood and brass; screw tools; bright and black carving chisels, gouges, &c.; yellow print-cutters; carving-chisels; gouges; parting-tools; spoon-bit chisels and gouges; engravers' and die-sinkers' tools of every kind and shape; sculptors' chisels; mezzotinto scrapers and shading-tools; plain and fluted scrapers; burnishers.

Braces, bits, turnscrows, spokeshaves, &c.

197 MARSHALL, SAMUEL, 25 *Eyre Street, Sheffield*—Designer and Manufacturer.

Specimens of illustrated Sheffield cutlery, consisting of razors, &c., carved, in mother-of-pearl handles.

Gentlemen's pocket combs, &c.

198 SAYNOR, SAMUEL, & SONS, 13 *Edward Street, Sheffield*—Manufacturers.

Pruning and budding knives, for the use of gardeners, seedsmen, horticulturalists, &c. Exhibited for workmanship and material.

199 NAYLOR, VICKERS, & Co., *Sheffield*—Manufacturers.

Illustrations of cast steel by models of furnaces, rolling mill, and forge. An assortment of manufactured articles.

200 WHITE, THOMAS, jun., *Thorpe Heeley, Sheffield*—Inventor and Manufacturer

Improved hooks for fixing gas and water-pipe, made either bright or black; a new form being given to the

shoulder of the hook, which facilitates the driving, and the bend is lengthened to secure the pipe.

Improved horse-nails, in order to secure the shoe without injuring the hoof.

New wrought-iron nails for ship-builders, carpenters, joiners, and cabinet-makers. The improvement of this nail consists in its gradual thickness towards the head.

Improved rivets, in iron, brass, copper, or zinc.

203 EYRE, WARD, & Co., *Sheffield*—Manufacturers.

Different qualities of table-knives, commencing with those manufactured for export to the United States, the Canadas, South America, and Australia. Medium qualities, of various kinds.

Ivory, silver, and other descriptions of table cutlery of the best description.

Razors, pocket and penknives, dagger and Bowie knives, made from the best steel, and of every variety in quality.

Scissors, scythes, and sickles, of the best qualities, for different markets.

204 SORBY, ROBERT, & SONS, *Carver Street, Sheffield*—Manufacturers.

An assortment of sheep shears, comprising Australian, American, Trinity, Saxony, Trowel shank, Scotch, Wiltshire or Sarum, Dorsetshire, Norfolk, Kent, Devon, Leicestershire, and Lincolnshire. Kendal snappers, flyers, gloves, horse and T shears, &c. Weavers' pods, assorted patterns.

Cast steel circular saw, 5 feet in diameter, hardened and tempered. Various cast steel, and London spring saws. Polished circular saws. Specimens of files for sharpening saws, &c.

Axes, consisting of American, Australian, Kent, Scotch, Suffolk, Newcastle, Longfalling, ship, coachmakers', wheelers', Newcastle, blocking, Irish bench side, American house, Dutch, mortice, bullock, and coopers', &c.

Adzes, consisting of coopers', carpenters', ship, wheelers', electro-Scotch, American and Canada, spout, &c.

Butchers' cleavers. House choppers and sugar hatchet. Mincing and cheese knives.

Hatchets, consisting of improved claw, hammer, Shingling, Suffolk, Kent, and Irish.

Hedging bills, consisting of Yorkshire, Westmoreland, Nottingham, Lopping. Improved S'Bill switching, &c.

Hoes, garden, turnip, Dutch improved turnip, half moon, long neck swan, neck, &c. Patent lawn or daisy and garden rakes.

Improved garden tools, complete, made to fit one handle, viz., spade, rake, hoes, saw, spuds, fork, &c. Spuds and weed hooks, assorted.

Axes which have cut the bars of iron attached to each; the edges of which have not been sharpened since.

An assortment of various kinds of augurs. Wheelers' bruzz and ship scrapers. Socket lock mortice chisel. Cast and German-steel gouges and chisels.

Tooth plane irons, and cooper's jointer plane with irons. Joiners', coopers', and wheelers' spokeshaves. Best plough bills, braces and bits, &c. Plated squares, plated spirit levels; various bevells. Turnscrows, of assorted patterns and lengths. Sawpads. Best cast steel long pod and shell gimblets. Planes: smoothing, jack, trying, plough grooving, bead, fillister, and rabbit. Skates, assorted patterns.

Cast steel patent scythes, consisting of improved narrow Scotch, broad Scotch, narrow Canada grass, cradling corn. Broad Suffolk, south of England, north of England, Yorkshire, and grass-plat scythes. Best hammered scythes, consisting of broad Scotch, narrow American grass, cradling corn, south of England and Bramber scythes; patent and crown hay knives, cross and side handle.

Crown trussing knife. Patent and crown chaff knives. Machine straw knives. Cast steel patent reaping hooks, round and elbowed. Improved registered reaping hooks, assorted. Garden and grass shears, assorted patterns.

204A LUCAS, EDWARD, & SON, *Dranfield, near Sheffield*—
Patentees and Manufacturers.

Malleable steel-spoke railway and plate-railway wheels, which are cast in one piece, and are hard on the surface, the interior soft or malleable: they are said to be much lighter than the ordinary wheel, and to wear well.

Malleable steel carriage, coach, and cart naves and axles, which are formed out of one piece; they occupy less space than the ordinary wood naves, and are less affected by the weather.

A case of spindles and flyers in use for spinning flax, wool, cotton, and silk.

Specimens of cast malleable iron manufactured by a process of which the exhibitors are the original patentees.

205 TASKER, H., *Sheffield*—Manufacturer.

Cast steel saws, polished and etched with silver and gold.

206 FISHER & BRAMALL, *Hoyle Street Works, Sheffield*—
Manufacturers.

Files and rasps. Ironstone, pig, and bar-iron. Bar and ingot steel; spring steel; shear, cast, and sheet steel; cast-steel, hand drawn.

Engineers' chisels, hammers, and nut-spanner. Mill-bill. Masons' chisels. Circular saw, for cutting railway bars when in a heated state.

[Iron is converted into steel by a process called cementation, which consists in placing iron bars in troughs of fire-brick, and covering them with layers of powder of wood charcoal, salt, and ashes. Dr. Ure is of opinion that the latter material is valueless. Care is taken that the iron bars do not touch each other. The troughs, when filled, are covered up with loam, and subjected to the action of a furnace, the heat of which is urged until it arrives at the proper temperature, and until the trough and its contents become one red-hot mass of matter. In this state it is maintained for a longer or shorter period, viz., from four to ten days, according to the nature of the steel desired; if soft, the time is shorter. The heat produces the combination of the carbon with the iron and completes the conversion of a soft substance into one of the most brittle; it then undergoes the process of hardening, by being plunged into cold water.

Shear-steel is formed by uniting together several bars of blister-steel by means of a steel rod, and sprinkling over it, when heated, sand. After being again heated, it is drawn out into a bar by means of a tilt hammer, viz., a large hammer, which works by steam or water power. Repeated heatings not unfrequently transpose the converted steel into its original state of iron.

Cast-steel is produced by melting blister-steel in crucibles, which is done after the manner of the brass-founder, in a common-air furnace. The mouth of the crucible is covered; the fuel used is coke. The metal, when melted, is poured into a mould, and acquires the name of "ingot steel."

Sheet-steel is produced by being rolled between revolving cylinders of metal.

Hand-drawn, means rods which have been produced by manual labour, in opposition to those formed by the tilt hammer.—W. C. A.]

207 EARL, SMITH, & Co., *Sheffield*—Manufacturers.

Files and rasps, of all shapes, kinds, and sizes, from half an inch to twenty-four inches long.

Samples of steel of various kinds and shapes, from blister to the smallest watch-spring, exhibiting the fractures from the state of pig-iron to the most highly-polished steel, with the tempers classed.

208 SLACK, SELLERS, & GRAYSON, *Sheffield*—
Manufacturers.

Cast-steel polished circular, mill, pit, frame, and cross-cut saws.

Spring, ripping, hand, and panel saws, in ebony, beech, and zebra-wood handles.

Gentleman's cast-steel hand and other saws, having tubulated backs formed of iron, German silver, and brass, with handles composed of various woods.

Gardener's pruning, fret, bow, wood-cutters', and other saws for cutting wood and metals.

Straw or chaff-knife, polished; ledger blade, cylinder of spiral cutters for shearing woollen cloth, &c.

[After the weaving of woollen cloth, the small fibres of the wool of which it is made are raised by means of teazle heads, or wire brushes; as a consequence, these fibres present irregularities in their several lengths, to reduce which to an equal or uniform surface, shears were formerly employed. These have been superseded by the application of a spiral cutting cylinder, which, being fitted with the necessary cutting edges, and revolving rapidly in contact with the cloth to be cut, and which is drawn on a ledge, speedily imparts to it the requisite uniformity of surface.—W. C. A.]

209 IBBOTSON, R., *Shoreham Works, 7 Shoreham Street, Sheffield*—Manufacturer.

Improved bill pruning saw. Black ebony plated handle saw. Rosewood handle saw, brass plate. Boxwood handle, blue back saw. Angica wood handle saw. London pattern hand and back saw.

210 MATKIN, T., *Hawley Croft, Sheffield*—Manufacturer.

Specimens of shears.

211 TAYLOR BROTHERS, JOS. & JOHN, *Burnt-tree Lane, Sheffield*—Manufacturers.

Specimens of saws:—American mill, cast-steel; Pit; Russian cross-cut; M-tooth, or continental cross-cut; circular; segment, or part-circular; suaged, or veneering circular; billet, or woodcutters' heb; and polished billet, Ohio or fleam tooth.

Ripping-saw, with French-polished boxwood handle, electro-plate screws. The novelty consists in the handle and the etchings which represent the different processes of saw manufacturing.

Sash or tenon-saw, with French-polished ebony handle, and electro-plate screws; with a representation of Windsor Castle and Park on the handle.

Hand-saw, with French-polished beech handle.

Polished hand-saw, with French-polished rosewood handle, raised steel screws, and etched.

Polished panel-saws, with French-polished box and zebra-wood handles, and etched.

Polished hand-saw, with Ohio or fleam tooth, French-polished ebony handle, raised steel screws, and etched.

Polished plate, brass back, sash or tenon-saw, with French-polished beech handle.

Polished panel saw, with French-polished ebony handle, electro-plate, and etched.

Panel-saw, with French-polished horse-flesh handle.

Ripping-saw, with French-polished zebra handle, and raised steel screws.

[The use of a ripping-saw is to separate the fibres of timber by eroding a portion of the fibre itself, to preserve an even way, and as an alternative to splitting. The crosscut-saw separates the fibre by a cut transversely, and effects more neatly and truly, and with less waste, what might be done with an axe; it cuts logs into shorter lengths, as the pit-saw slits logs into boards.

The tooth of a ripping-saw is more or less hooked, that of the pit-saw being shaped something like the upper mandible of a parrot; whilst the tooth of the crosscut-saw returns from its point or apex at an equal angle on

both sides of a line at right angles to the edge of the blade; consequently the ripping-saw bites in the down-stroke only, whilst the crosscut-saw can cut both ways; and it does so when worked at both ends, as in cutting logs of large sizes.

The saw blade is commonly thicker at the serrated edge than at the back; both that it may not be unnecessarily heavy, and that it may not bind in the cut or the kerf (the ripping-saw makes a cut, the crosscut-saw a kerf), though this latter object is more fully provided for by the setting of the saw; the setting being the bending outward of every tooth alternately on one side and on the other, to such an extent as the nature and condition of the wood, in respect of woolliness and wetness, or their opposites, may render a wider or a narrower *way* necessary or sufficient for the free passage of the blade along the cut or through the kerf.

Tenon-saws are crosscut-saws mainly, and as their name imports, for cutting in the shoulders to tenons. But these are shallow cuts, and requiring to be made with neatness, the blade is made rigid by a back which is commonly of brass. Narrow-bladed saws, for cutting in curved lines, are made thicker at the edge, and thinner at the back, and are not set.—W. H.]

212 BIGGIN, SAMUEL, & SONS, *Sheffield*—Manufacturers.

1. Ripping-saw, polished blade and handle, with silver shield, ornamented.
2. Hand-saw, with ebony handle, ornamented.
3. Hand-saw, zebra handle, and ornamented with a representation of the Exhibition building.
4. Ripping-saw, polished ebony handle, with raised silver screws.
5. Back-saw, polished blade and handle, with silver shield and fluted back.
6. A similar one, with zebra handle.
7. Another, with silver back, engraved and etched on blade.
8. Another, polished blade and satin-wood handle, silver back, and etched blade.
9. Back-saw, polished blade and handle, silver back, and handle inlaid with silver, shield engraved.
10. Another, with a bright back.
11. A similar one, blued.
12. Hand-saw, polished blade and rosewood handle, ornamented, with silver screws and etched blade.
13. Hand-saw, polished blade, and satin-wood handle, decorated with silver shield and etched.

213 WHITTLES & FROGGART, 100 *West Street, Sheffield*—Manufacturers.
Surgical instruments and penknives.

214 STANFORTH, THOMAS, *Hackenthorp, near Sheffield*—Manufacturer.

Sickles and hooks used in England. Hooks used in Wales. Sickles and hooks used in Ireland and Scotland. Sickles used in Poland and Russia. Sickles and hooks used in North America, United States, South America, and West Indies.

Scythes used in England, Ireland, Scotland, and North America. Bramble scythe used in the United States.

215 HUTTON & NEWTON, *High-lane, near Sheffield*—Manufacturers.

Patent and crown hay and straw knives.
Crown and patent scythes, suitable for the colonies of New South Wales, Australia, &c.
Crown and patent narrow Canada grass scythe.
Iron socketed grass hook, suitable for the East Indies.
Sickle, suitable for the colony of the Cape of Good Hope, &c.

Best bright Russian sickle, with polished handle, hoop, and ring. Polish and Canadian sickles.

Reaping-hook and sickle, suitable for Australia, New South Wales, &c.

Bagging or fagging hook.

Sickle, suitable for the United States of America.
Spanish and rice sickles.

216 SHAW & SON, *Sheffield*—Manufacturers.
An assortment of magnets.

217 CUTLER, J., *Sheffield*—Manufacturer.
A variety of edge tools.

218 MARPLES, WILLIAM, *Sheffield*—Manufacturer.

Kingswood plated brace, with straw coloured bits.
Beechwood unplated brace, without bits.

Centre bits. Brace with improved pad, by which the bits are introduced with much greater facility into the receptacle provided for holding them.

219 CARFITT, THOMAS, & SON, *Sheffield*—Manufacturers.

A collection of scythes, suitable for mowing or cutting, and used for the various purposes, and in the various counties and countries, enumerated as follows:—

Garden and grass-plot borders. Canada. Rice. Forged Cheshire. Cheshire, showing the under side. American corn, showing the under side. Broad-pointed Cheshire. Yorkshire, West Riding. Yorkshire, East Riding. Westmoreland, &c.

Knives for chaff, rag, and turnip machines. Chaff-box. Hay-trussing, hay-knife, and shear-steel round.

Elbowed, Irish, and bagging hook. Cast-steel round. Cast-steel Kendal hook. Round, ribbed, crane, elastic, Cheshire and Kendal sickles.

The patent scythe, consisting of a cast-steel blade, with an iron rib rivetted upon the upper side, and elongated at the heel of the scythe into a tang. One of the peculiarities of this scythe consists in the blade and flange-rib, the back edge of which turns up, and meets the flange of the rib, to give it strength and lightness. The forged scythe consists of steel, which forms the edge, welded between two strings of iron, as a back.

220 SKELTONS, SAMUEL & RALPH, *Sheffield and Attercliffe*—Manufacturers.

Shovels and spades for various uses. Draining-tools.

221 TASKER, JOHN, *Sheffield*—Inventor and Manufacturer.

Pair of cricket shoes with gutta percha bottoms; made principally by machinery, applicable to the manufacture of various kinds of boots or shoes; superior for durability and appearance; made in one-third of the time, and much cheaper than the ordinary boots or shoes.

222 BURROWS, SAMUEL, 94 *Spring Street, Sheffield*—Manufacturer.

Specimens of table cutlery in black tip, self-tip, white bone, German silver, ivory, plated on steel, and ivory and pearl; with patent steel blades, and ornamental shanks.

223 COOPER, G., *Wicker Lane, Sheffield*—Manufacturer.

Specimen of registered Venetian chimney-top. Designed to create an upward draught, and to prevent downward draught. The lower courses are intended to give a direction to the wind impinging against them, which produces an upward current, and the top courses intercept and break the force of all wind from above, before it can in any way affect the flue.

As there are no parts of this chimney-top where soot can lodge, it will always be kept clean by the wind blowing through it.

224 HINCHCLIFFE, JOHN, 8 *Hermitage Street, Sheffield*
—Manufacturer.

Flambeaux dagger hunting clasp-knife, 10½ in. haft, carved in pearl representing the cutlers' arms, with carved scrolls and flowers in bas-relief, cased in gold edge, with gold guard.

Gentlemen's Wharncliffe knives, in pearl, shell, ivory, and stag handles. Ladies' knives, in pearl, ivory, &c. American hunting lock knives, in fancy handles, &c.

225 LEON, ABRAHAM, *Sheffield*—Manufacturer.

American hunters' knives, various sizes from 20 inches downwards, in Morocco and electro-plate sheaths.

Dagger knives, electro-plate and Morocco sheaths, with black and pearl-dotted handles.

Also, pierced electro plate, with silk velvet sheath.

226 SANDERSON, THOMAS JOSEPH, *Sheffield*—
Manufacturer.

Anvils for the use of engineers, blacksmiths, and farriers. Anvil for exportation. Bright and black vices, for blacksmiths. Bright saw vice.

226A HAGUE, S., *Devonshire Lane, Sheffield*—
Manufacturer.

Fancy penknives, varying in the number of blades, with corkscrews, silver pencils, &c.; and handles of tortoiseshell, mother-of-pearl, ivory, and horn.

228 HUNTER, E., *Broomhall Street, Sheffield*—
Manufacturer.

Scissors and shears of all descriptions, with modern improvements.

Specimens of these articles, in the various stages of manufacture.

229 NELSON, JOHN, *Sheffield*—Inventor.

Set of parturition forceps, for difficult parturition in domesticated animals.

Pair of forceps for giving balls to horses.

230 JONES, J., 33 *West Field Terrace, Sheffield*—
Inventor and Patentee.

Glass for sash-bars, frames, columns, cornices, windows, looking glass and picture frames. The glass is flint and coloured, and is plain, moulded or cut.

231 LINLEY, G. A. F., 43 *Regent Street, Sheffield,*
Yorkshire—Designer and Manufacturer.

Horse-shears and sheep-shears.

Wool-sorters or thatchers' shears.

Improved gentlemen's grass shears.

Glovers', belting or dragging, and rag shears.

232 BELL, JOHN & JONATHAN, *Sheffield*—Manufacturers.
Silver fruit knives.233 PEACE, JOSEPH, *Sheffield*—Manufacturer.

Hand-saw, ornamented japanned handle.

Ripping-saw, rosewood handle, with registered plates.

Hand-saws, zebra and ornamented japanned handles.

Back-saws, zebra, rose, and beech-wood handles, with and without brass backs.

Panel-saw, hand-saw, and ripping-saw.

Hand-saw, English measure on the back.

Back-saws, various sizes, and some with brass backs.

The above are all ornamented on the plates in a new style.

Russian crosscut-saw, plain and blued, with the mark gilt. Russia frame-saw. Mill-saw web. Brass-back saw, zebra handle and steel screws. Iron-back saw, beech handle, &c. Saw cook knives. Turkish dagger. Pannel-saw, mahogany handle, steel screws.

Hand-saw, zebra handle, registered plates, and English measure on the back. Chopping-knife. Turkish hand-saw.

Large circular saw, with spindle and spanners complete, each tooth ornamented with a bird's head, the

plate ornamented with the English, American, Russian, and Sheffield arms. Spring steel hand-saw, with registered plates in brass. Billet-web. Spring steel hand-saw, with registered plates in polished steel.

Glass frame, containing registration deed for the improved plan of plating saw-handles.

Glass case, containing old style of marking saws and the new style introduced by the exhibitor.

Glass case, containing saw-handles, with plates in the old style and in the new registered style.

233A PEACE, HENRY, *Sheffield*—Manufacturer.

Samples of files and rasps of every description.

234 COCKER & SONS, *Hathersage, Derbyshire*—
Manufacturers.

Needles, in every stage of their manufacture, from the wire of cast steel to the finished article.

The exhibitors, being the drawers of card and other wire, a process which originated with their ancestors, a century ago, Mr. Huntsman, of Attercliffe, who first refined carbonated iron, and which has been a source of great wealth, not only in the manufacture of cast steel, but in the great variety of articles of cutlery for which Sheffield is so celebrated, suggested to them that it would be mutually advantageous if they could succeed in drawing cast steel made from his carbonated iron. The suggestion was adopted, the attempt was made, and the cast steel and the wire made from it are now articles of very extensive exportation.

Specimens numbered in the order of manufacture:—

Wire: 1, cut double length of a needle; 2, straightened; 3, pointed at each end; 4, grooved, for two needles; 5, eyed, for two needles.

Needles: 6, threaded; 7, filed on the sides; 8, filed on the heads; 9, broken in two; 10, drilled in the eye; 11, hardened; 12, tempered; 13, straightened; 14, scoured, first time; 15, scoured, second time; 16, scoured, third time; 17, scoured, fourth time; 18, glazed; 19, headed, and picked from waste; 20, blued in the eye and groove; 21, drilled in the eye; 22, first extra polish; 23, second extra polish; 24, third extra polish; 25, blued in the eye and groove; 26, gold-eyed; 27, papered, twenty-five in a paper; 28, papered and tugged; 29, papered in envelopes; 30, labelled, in envelopes, and on purple paper; 31, in cases.

Wire of various kinds:—32, pinion and click wire, for clocks and watches; 33, music wire, for pianofortes; 34, watch and chronometer spring wire; 35, cast steel, hammered flat, half flat, and square.

Nos. 36–41. Hackles, from large hatchel to 180's fine. Gills, for dividing the fibres of flax in machinery. Hackle-pins. Gill-pins. Wool-combers' broaches. Spiral springs.

42. Particles of cast steel, taken from pipes used in conveying away the dust occasioned in grinding needles on dry stones, and which would, if allowed to float in the air, be inhaled by the grinders, thereby causing a complaint until lately very common, and hitherto incurable.

[About twelve or fifteen years ago, several methods were tried to remedy this, but they did not effectually succeed until a powerful fan, as represented in the plan hanging on the boards at the end of the counter, was put up, on which is shown a grinder at work, and the blaze of fire arising from the stone in the act of pointing, with the fan underneath, drawing the dust and particles of steel down the pipe, and leaving the atmosphere of the room perfectly clear and free from all injurious effects; so that dry grinders have now the chance of living as long as other men; without this apparatus they cannot now be induced to work; it is therefore universally adopted.]

235 BROWN, JOHN, *Atlas Steel Works, Sheffield*—
Manufacturer.

Conical railway spring buffer, with wrought-iron cylinder plungers of varied actions and resisting powers, suit-

able for waggons, goods vans, locomotive engines and tenders, and passenger carriages. The following illustration represents this buffer.

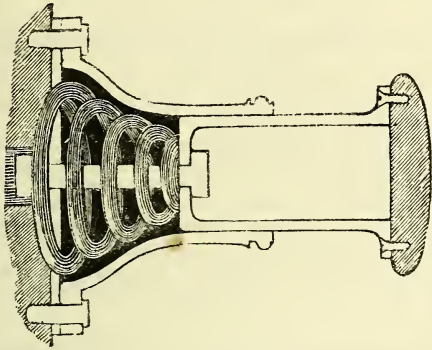

Patent conical railway drawing spring, for railway-carriages and waggons, of 3-inch action, and 75 cwt. resisting power, with one pair of miniature brass buffers, which may be pressed to show the action. The mechanical action of these springs consists in one coil falling within the other until they assume a planular form. They are capable of adaptation to any description of railway plant.

Conical buffer springs, without fittings.

Laminated railway-carriage and waggon buffer and drawing spring, weighing 200 lbs.

Passenger railway-carriage spring, with tension bar and clips complete, weighing 127 lbs.

Railway goods van spring, with spear-point ends, and extra steel cushion bearings, weighing 112 lbs.

Mineral waggon bearing springs, weighing 70 lbs.

Registered mineral and goods waggon bearing spring and clip. The improvement in this spring consists in its bearing from the centre, and thus bringing into action the whole length of the plates; the spring is also strengthened by having studs in the centre, instead of holes punched through to hold the plates together; weighing 62 lbs; resisting power, $4\frac{1}{2}$ tons.

Improved railway-waggon bearing spring, with tension rods; intended to be used where great action is not required, and to provide for the inequalities in the height of waggons when loaded; weighing only 44 lbs., with 4 tons resisting power.

Specimens of engineering and machine files.

236 HUXLEY, HERIOT, & Co., *Castle Street, Long Acre*
—Inventors and Manufacturers.

Cook's patent self-regulating stoves for attaching to brick flues, with new mode of controlling and preventing excess of heat. Self-acting regulator, as used on Cook's patent stoves.

Economic gas stove for heating water or warming rooms. Gas stove with enclosed cockle, from which the products of combustion are carried away.

Hydraulic stove, heated by gas, the cylinder containing water suited for small conservatories, &c., or to place horizontally enclosed in ornamental case.

Ornamental candelabrum for gas, lacquered or-molu. Elizabethan chandelier for gas, designed by Mair. Fancy chandeliers for gas, and ornamental bracket for gas, new designs.

237 JEAKES, WILLIAM, *51 Great Russell Street*—
Inventor, Designer, and Manufacturer.

Improved ventilating stove grate, the heating surfaces of which are composed entirely of pure fire loam, the object being to prevent the decomposition or burning of the air. The air which feeds the fire is supplied from an external source, and thus all draughts are prevented.

Improved grate for the chimney-piece, exhibited by Mr. Thomas, of Church Street, Paddington.

238 GLENTON & CHAPMAN, *147 New Bond Street*—
Manufacturers.

White marble statuary chimney-piece, with carved foot and trusses.

Bright polished steel register-stove, with rich or-molu ornaments, in style of Louis Quatorze.

Bright polished steel fender and fire-irons *en suite*.

Improved portable vapour-bath, with cloak complete, in a japanned box.

239 PRIDEAUX, THOMAS SYMES, *2 Garden Road, St. John's Wood*—Inventor.

Dwelling-house grate, consisting of a simple plan of feeding at the bottom, by which smoke is prevented, and economy attained.

Model of a patent steam-engine boiler, capable of supplying a great quantity of steam in proportion to its size and expenditure of fuel.

Model of a patent machine for cutting agricultural drains in clay soils. Also adapted to land requiring minute subdivision.

240 BUTTERLEY, RICHARD, *Greenhill, Sheffield*—
Manufacturer.

1. Patent Irish hook, No. 3, cast-steel blade, elastic back; rivetted.

2. G. B. sickle, cast-steel, No. 4; coarse cut.

3. Improved elastic sickle. Its lightness, strength, and elasticity have given it an advantage over every other kind of sickle, which has been fully proved. Exhibited for special inspection.

4. Elastic cast-steel Andrew hook, large size, combining lightness and strength.

5. Elastic cast-steel Kent sickle, No. 4; very light, with sufficient strength.

6. Scotch sickle-hook, shear-steel, No. 0; cut to the point.

7. Small grass-hook, universal, No. 0; shear-steel.

8. Bright Russia sickle, elastic cast-steel, No. 2.

9. Bean, or brushing hook, elastic cast-steel, No. 2.

10. Kendal hook, shear-steel, No. 4.

11. John Bull sickle, elastic cast-steel. Exhibited for its superior qualities, which have been tested by four years' hard service.

12. The Tomlin shaped sickle, shear-steel, No. 4.

13. Poland sickle, cast-steel, No. 1.

14. Elastic cast-steel Philadelphia sickle, No. 5.

15. Elastic cast-steel Yorrack sickle, No. 5.

16. Shear-steel Hollander sickle, No. 1.

17. Elastic cast-steel Windsor hook, No. 5; cut at the point.

18. Elastic cast-steel elbowed Scotch hook, No. 3.

19. Elastic cast-steel bagging-hook, No. 8.

20. Elastic cast-steel 28-inch yowing-hook.

241 EDWARDS, DAVID OWEN, *5 Sydney Place, Brompton*—Inventor.

Patent "atmopyre" hoods, or artificial embers; they are made of porcelain; the gas is introduced into the interior, and escapes through small perforations in the sides, 1-50th of an inch in diameter, and when ignited, burns with a pale blue flame, and emitting little or no light, in a few minutes the mass becomes red-hot. They thus constitute, when used in the aggregate, a solid fire.

The inner case, in which this artificial fire is contained.

An example of a complete atmopyre, adapted to the heating of apartments.

A kitchen range of porcelain, adapted to bring into use the atmopyre hoods.

[Chemists have long employed gas burnt in the manner described for the purposes of the laboratory on a small scale. By covering a cylinder of copper with wire gauze, and discharging coal gas into the lower part so as to cause it to unite with a certain volume of atmospheric air, a gaseous mixture is produced, which burns over the wire gauze with a blue lambent flame. The perforated hoods

of porcelain, in the invention described, are the representatives of the chemists' wire gauze, with the advantage, for heating purposes, that they retain a portion of the heat developed by the combustion of the mixture of coal gas and air, which is remarkably intense.—R. E.]

242 WHITMEE & CHAPMAN, 18 *Fenchurch Buildings*, 70 *St. John Street*, and 11 *Ray Street*, *Clerkenwell*—Manufacturers.

Registered mill for grinding coffee, with anti-friction wheel to carry the fly-wheel. Coffee-mill, of different design.

Universal corn-crusher, for bruising oats, barley, malt, beans, peas, linsced, &c.; the same, with an extra mill attached, to grind barley meal.

Flour-mill, with French bean stores and dressing machine for grinding and dressing flour at one operation; the same, with steel mill and dressing machine.

Smoke-jack for roasting meat, &c.

243 POPE, WILLIAM, & SON, 80 & 81 *Edgeware Rd.*, and *Grove Foundry*, *Lisson Grove*—Inventors and Manufacturers.

Patent double-action rarefying stoves, ornamented. Section, showing the internal arrangements.

243A SHERWIN, JOSEPH, 21 *Norton Folgate*—Manufacturer.

Economic range and supply cistern, hot closet, steam kettle, tea-kettle, bath, and bath stove.

244 CROOK, WILLIAM, 5 *Carnaby Street*—Inventor and Manufacturer.

Hot plate, oven and boiler, kitchen range, and improved outside movement smoke-jack, with dangle movement and cradle spit.

Tailors' stove; a larger number of irons can be heated, with a smaller quantity of fuel, and in less time than by the ordinary stove.

245 CORNELL, T., MESSRS. FEETHAM'S, *Clifford Street*, *Bond Street*—Inventor and Manufacturer.

Model of a cooking apparatus, to be used either with coal or gas. Suitable for club-houses and other large establishments.

247 BURTON, WILLIAM SAMUEL, 39 *Oxford St.*—Inventor and Manufacturer.

New nautilus register stove. Fender, and chimney piece for the same. See the cut below.

Registered ornamental fenders. Sundry metal wares.

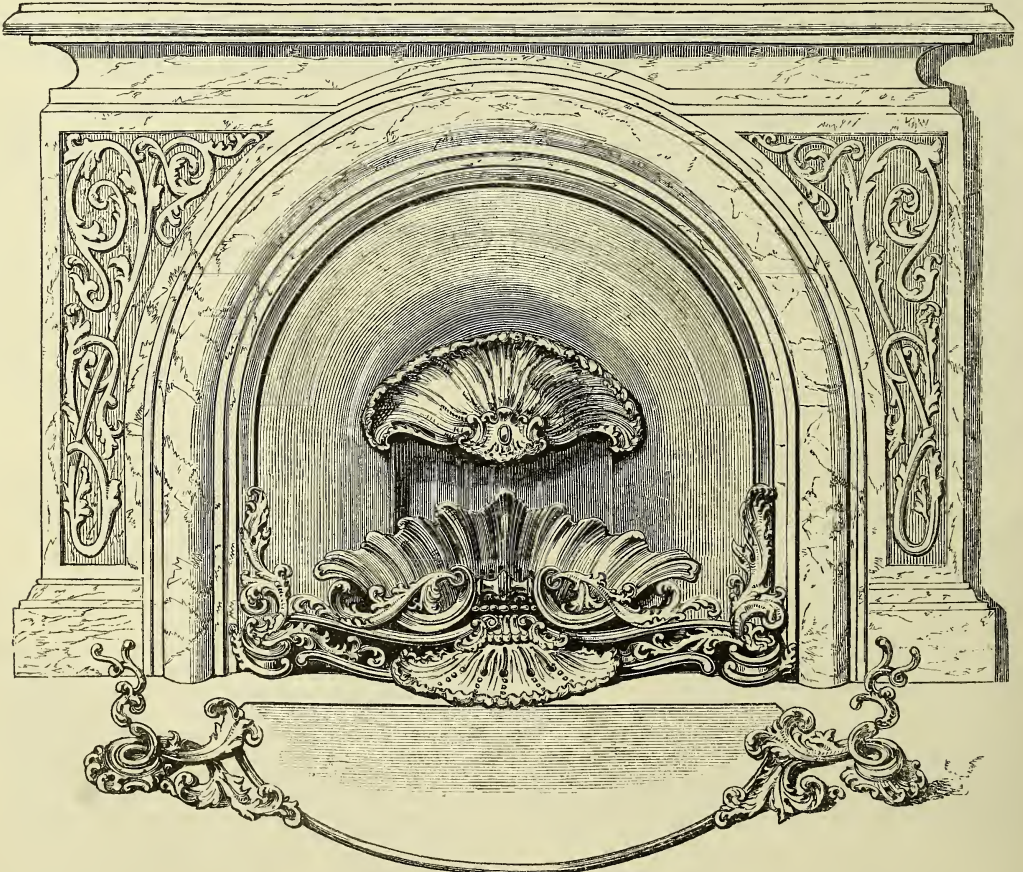

Burton's Nautilus Register-stove.

248 WARRINER, GEORGE, 16 *Arundel Street*—Inventor.

Gas stove for cooking, made of fire-clay enamelled, which retains and radiates the heat and causes a saving of gas.

Gas bath for heating water sufficient for a large bath in ten minutes, at the cost of one penny.

249 ONIONS, JOHN COLLINGWOOD, 63 *Bradford Street*, *Birmingham*—Manufacturer.

Pair of 42-inch smith's bellows. Pair of 36-inch smith's bellows, with galvanized iron work.

Improved portable forge, complete, with vice.

House bellows, fancy satin-wood. Mahogany and japanned bellows, different patterns.

250 **CARTWRIGHT & HIRONS**, 138 & 139 *Great Charles Street, Birmingham*—Designers and Manufacturers.
Electro-plate on German silver:—Waiter. Revolving liqueur-frame. Antique cruet-frame, supported by dolphins. Cruet-frame. Salad or fruit-stands. Butter-coolers. Sugar-baskets. Egg-frame. Inkstand. Cake and fruit basket. Card-baskets. Small flower-stands, &c.

251 **TAYLOR, SAMUEL**, 117 *New Canal Street, Birmingham*—Manufacturer.

Specimens of bellows, as follows:—Alhambra, arabesque, and mahogany, in red morocco; Chinese, mahogany, American birch, fancy walnut, in green morocco; pear-tree, in puce morocco; and a fine article, in neat's leather; with a common article, adapted for the export trade.

252 **STOKES, JOHN C.**, *Monmouth Street, Birmingham*—Inventor.

Registered water-closet, fitted in mahogany case to exhibit the working of the apparatus when fixed. Cabinet water-closet, made of china and earthenware: manufacturers, Messrs. Ridgway & Co., Caudon Place, Staffordshire Potteries. The annexed cut gives a representation of this object.

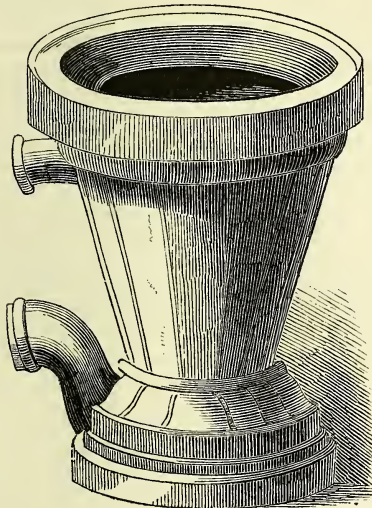

Ridgway & Co.'s Cabinet Water-closet.

Registered brass tap, capable of bearing great pressure without leaking.

Improved shoe and round valves, with one flange instead of two, the weight and ball being tapped and threaded so as to admit of new leathering without removing the valve.

253 **ALLDAY, WM.**, 32½ *Constitution Hill, Birmingham*—Manufacturer.

Japanned bellows, inlaid with pearl, with view of the cathedral of Notre Dame, Antwerp. Japanned dust-bellows, with pearl flowers, Gothic shape. Fancy bellows. Chamber bellows, rosewood, carved, and French-polished. Parlour bellows, walnut, turned top. Mahogany bellows, with brass pipe and nails, French pattern. Common kitchen bellows. Fumigating, or spring bellows, used for destroying insects on plants, in gardens, hothouses, &c. Small smiths' bellows, with galvanized nails, made in the original London style. Lamp bellows, used for soldering.

Small fancy tortoiseshell bellows, inlaid with pearl. Small fancy bellows, tartan pattern; one pair covered with satin. Small dust bellows. Butchers' bellows, used in puffing up meat. Pair of bellows, maple wood, scooped edges. Pair of 24-inch round bellows, with frame complete.

Improved portable forge, with vice and hearth attached.

254 **GRIFFITHS, THOMAS F.**, 68 *Bradford Street, Birmingham*—Manufacturer.

Articles in tinned iron:—Venison dish and cover and soup tureen and cover; stamped, no seam or brazing. Hot-water dish and cover, and spirit-lamp dish and cover. Hot-water vegetable dishes and covers; oblong dish-cover; oval-dome top dish-covers, and soup tureen and cover; no seam or brazing. Oblong vegetable dish and cover, gadroon edge. Stamped hot-water plate; the same with earthen plate. Oblong tea-urn. Round tea-urn. Round coffee-urn with filter. Stamped tea kettle. Plate-covers, and extra large Albert dish-cover, no seam or brazing.

Tinned iron tea and coffee services. Copper-tinned cake and jelly moulds. Copper moulds made by hand. Iron moulds, stamped. Rare and curious iron stampings. Tinned iron and copper saucepans, no seam or brazing. Tinned iron candlesticks. Tinned iron, copper, and brass funnels. Tinned iron flour-dredger, no seam or brazing. Tinned iron tobacco box.

Carey's Hecla coffee-pots on stand, with spirit lamp, each bright and bronzed. Carey's Hecla, for the fire. Tinned iron egg-cup. Rare and curious iron culinary goods, coated with glass. Ornamented toilet services. Ornamented toilet vase, in iron.

[This coating with glass, a kind of enamel, is a French invention, and the powder of which it is composed is imported; the article to be coated is gummed or sized over, the glass-powder dusted upon it, and by exposure to heat, or a properly constructed oven or muffle, the whole is fused and coated.]

The specimens of iron stampings are peculiar, as exhibiting the ductility of the iron, and certain improvements in the mode of raising, which is accomplished by pressure and repeated annealings.—W. C. A.]

255 **COPE & COLLINSON**, *Birmingham*, and 53 *Berwick Street, Soho*—Manufacturers.

Specimens of castors for furniture, as formerly made; and of Cope's first patent improved castors, having three rollers working round an upright spindle, with a conical bearing. Specimen of patent round socket, and other castors having a cup-and-ball action, separated to show the parts.

Complete series of socket and plate castors. Specimens of various fancy patent castors.

A large plate-castor, used for large dusting platforms.

Windsor pivot-castor, having a pin or pivot action working downwards in a socket, open to show the principle.

Series of patent movements for dressing-glasses, with model, to show the application; the centres are iron balls working in jointed frames, and tightened by a screw.

Patent globular blind mountings, with model: the action is a ball compressed in a moveable frame acted upon by a set-screw, with a clip-guide to keep the cord tight while winding round the barrel or roller.

Model, showing the application of a patent bedstead-brace by a centre screw combined with a curved wrought-iron plate, drawing the posts and rails firmly together; the action is inside the framing.

Registered music-stool screw, of which the improvement consists in the screw being enclosed in a case, the upper part of which is lined with an elastic material, while in the lower part the nut is firmly fixed.

Registered Venetian blind, with model, showing its application; it is wound up like a roller blind, with a rack and lever; when the lever is released it brings down a break on the roller, which regulates the action, and prevents it from falling suddenly.

Folding ornamental Essex fire-screens, with brackets to fix to the wall.

Series of different sizes of Horne's patent butt hinges, with illustrations to show the different stages of manufacture, from the rough-drawn metal to the finish: this

hinge being made from drawn metal, by machinery, is true, and of uniform strength and thickness.

Specimens of locks, hinges, springs, and iron work used in the manufacture of pianofortes.

256 **ROCKE, WILLIAM, Dudley**—Inventor.

Rails, ornaments, hinges of large size, cranks for engines, nails, burs or mits for screws, all cast from wrought iron scrap from the cupola of a foundry, showing that anything cast from metals may be cast from wrought iron, and its quality for toughness retained.

[The process of manufacture here alluded to is a patent invention of some importance. Hitherto malleable cast-iron has been produced by surrounding the articles with powdered iron ore, and exposing them for days to the heat of an annealing furnace. By the process here illustrated, old rails may be remanufactured.—W. C. A.]

257 **HARCOURT, WILLIAM & JOSEPH, 209 Bristol Street, Birmingham**—Manufacturers.

Specimens of brass foundry used by bell-hangers, consisting of bell-levers, pulls, horizontal and quadrant, some newly designed.

Specimens of brass and iron bell carriages, and of the cast iron registered bell carriage (the first made in iron). The improvement in the latter consisted in substituting wrought iron stands and plates with brass arms to increase its durability and protect it from rust.

Purchase cranks with iron backs, &c.

Specimens of door-handles, tea-bells, cornice-poles and ornaments, hat and coat hooks and castors, of new and ornamental construction.

Vases in various styles: bronze, electro-silvered, dead gold and relieved; also fitted with improved spring igniter for lighting the vesta matches.

Plain and ornamental brass boxes for holding vesta matches and wax tapers in various styles of finish.

Plain three-quarter covered cornice-pole, mounted complete, with centre ornamented *en suite* with the bands and ends, and with Arrowsmith's patent damask curtains resembling cut velvet-pile.

258 **SOLLY, JAMES, Leabrook Iron and Steel Works, Tipton, near Birmingham**—Manufacturer.

Specimens of English iron for conversion into steel; and of various kinds of steel; and articles of hardware and cutlery, made from the steel, namely:—

Elliptic carriage spring; hand-saws and circular saw; files of various kinds.

Bush chisels and gouges. Carving, dinner, and dessert knives.

Scissors. Pocket and penknives of various kinds. Razors.

These articles are specimens of steel and steel goods, made of English iron.

261 **MALINS, D., & SON, Birmingham**—Manufacturers.

Brass window-cornices and ornaments. Poles, with ends, rings, and brackets. Curtain bands and pins. Finger-plates for doors, brass and japanned.

[The rich dead gold-like colour given to brass work, and which has been introduced within the last thirty years, was discovered as the result of an accident. The work is first "sealed" (or roughly cleansed) by immersion in a weak solution of acid, it is then what is technically called "fezzed," viz., the work passed through a stronger solution; "deadening" follows, and this is effected by means also of acid, but of such a degree of strength that the action on the metal though recognisable is not of a violent kind; attention is necessary to this point, otherwise the work when finished will present a mottled

appearance; it is now dried out in saw-dust, and is then passed through acid of ordinary strength and dipped into water, of which there should always be an abundance at hand, until the acid be removed. The bright parts on the metal are produced by burnishing; gall is used in connection with the steel burnishers to prevent their scratching, and the article to be burnished is from time to time plunged into argol and water. When finished from the "burnisher," it is dried out in boxwood saw-dust, and then lacquered.—W. C. A.]

262 **GRAY, A., & SON, 9 Wenman Street, Birmingham**—Manufacturers.

Highly polished steel fire irons, with engraved burnished steel pans, and diamond, octagon, and hexagon cut; twisted, fluted, and scalloped shanks; with cut steel, or-molu, bronzed, silvered, and gilt, China, glass, pearl, and ivory heads.

Standards for fire irons; with octagon, hexagon, and twisted pillars, and horns varied in steel and or-molu.

"Pokerettes;" with octagon, sexagon, and twisted shanks, and cut steel grips.

Coal vase tongs; with octagon, sexagon, and twisted shanks.

[Fire irons are produced by forging out of square bars of iron; the swells and other ornamental parts are formed by means of "swages," a sort of mould, one portion of which is placed on the anvil, while the other is held by a "willow twist" in the hand, and struck with a hammer until the form desired is arrived at; certain parts are then filed; the round portions are turned in a lathe. The articles are case-hardened by laying them in an iron box, and covering them with animal charcoal, formed of burnt leather, hoofs, &c.; the whole is subjected to the operation of a fire or stove until heated to a uniform red heat; the box and its contents are thereafter taken out and plunged into water. Polishing succeeds, which is done by holding the article against a wheel, to the circumference of which emery is attached by means of glue; another wheel or "bob," with finer emery, gives a higher degree of finish, and the final and brilliant polish is given by hand-friction with powdered iron-stone. The more highly wrought qualities, in which squares, angles, or cuttings are introduced, are, after filing, finished on a soft-metal wheel; the twisted varieties are produced by the forger, who, when the metal is heated, twists it into a screw or spiral; the pans of the shovels, &c., are formed by the stamp, and perforated by the press; the ornaments and studs are produced also by the stamp; they are afterwards ground and polished on a soft-metal wheel; and handles of China, glass, bronze, pearl, &c., are occasionally introduced.—W. C. A.]

263 **HANDS, JOHN, Prospect Row, Birmingham**—Manufacturer.

Specimens of ornamental stamped brass-foundry; cornice pole ends. Curtain bands; registered designs. Finger plates for doors. Pins for curtain supports. Ornaments for cornices and other purposes. Ornaments for watch hooks. Holders for bell ropes and ribbons. Frames for miniatures or pictures. Coffin furniture; real gilt; plated; brass; and improved black, &c.

[Brass is a composite metal, its base being copper, the addition of zinc, in various proportions, transforming it into a yellow metal. It is very ductile, and is capable of being drawn into wire, flattened, or laminated into sheets, the latter operation being effected by means of rolls, which are propelled by machinery. It is in this state that it is used by stamped brass-founders. Stamped brass-foundry is

produced by means of a "matrix, or die," a "reverse," and a stamp. The "die," formed of steel or cast-iron, is fixed by four screws to the bottom of the stamp; the "reverse" is attached to the hammer. Pieces of thin brass are selected and cut to size, one of which is laid on the die; the hammer is released, and the "reverse," which is attached thereto, falls with it, and forces the thin metal into the matrix. It is then annealed: some slight alteration is made in the "reverse," by means of which it impresses more deeply, by its action from behind, forces the thin plate into the die, and thereby copies accurately all the details marked therein. Repeated annealings follow, and in many instances twenty or thirty blows are given before the article is "brought up." The nature of the operation precludes undercutting. All portions of the "reverse" must be tapering; the die must also be the same. Globular articles are stamped in halves and soldered together thereafter.—W. C. A.]

264 LINGARD, G., 67 *Show Hill, Birmingham*—
Manufacturer.

Patent dovetail lock, having one solid bolt working in a dovetail slide, with the lock and tumblers themselves in the bolt, reducing the several parts of a lock into but two leading ones, viz., the bolt and frame; the dovetail, like a wedge, keeps bolt and frame inseparable, allowing it still complete action. The key, though small, acts as well as a large one, and gives equal security.

Patent dovetail lock, showing the action when fitted.

Registered air-vent cock: when the plug is turned on for the purpose of drawing liquor, the air enters the outer tube, and passing through the plug down the shank, into the barrel, causes the liquor to flow, rendering a vent peg unnecessary.

Coffin furniture, in gold, silver plate, British plate, brass, and tin japanned, also medal and button dies, &c. Patent table furniture, glass movements, window fasteners, &c.

265 ABATE, FELIX, 3 *Ernest Street, Albany Street*—
Inventor.

Specimens of a new art, called metallography, which consists in printing and ornamenting any kind of metallic surfaces, so that bright letters or ornaments appear as though they were inlaid upon a dark, coloured, or wood-like surface. This is effected by two different processes, the one, electro-chemical, and the other, chemical; applicable to the painting of ordinary inscriptions, names of streets, door-plates, shop-fronts, sign-boards, show-bills, &c.; and for printing illustrations from wood-cut engravings, maps, and any ornamental printing.

A zinc board, with an ornamental border, and an inscription in the centre. Table of zinc, ornamented.

Zinc and brass ornamented tubes, for cornice-poles.

Zinc plates, printed from wood-cut engravings.

Board covered with tinsel, containing the words "provisionally registered."

Three working models of machines for smoothing, planing, burnishing, and ornamenting sheets, bars, and tubes of metal or wood. Various specimens performed by the same machines upon metals and wood. The above inventions are provisionally registered in Great Britain and Ireland, and patented in France and Belgium.

266 WILKES, J., *Birmingham*—Manufacturer.

Specimens of locomotive and marine boiler tubes. Brass and copper gas tubes, and wire. Sheet brass.

267 BIRD, A., *Birmingham*—Inventor.

Hydrostatic syphon water-purifier, intended to be dropped into any vessel containing water, and the pipe hung down outside, in which position it acts as a syphon. The following cut represents this purifier in action.

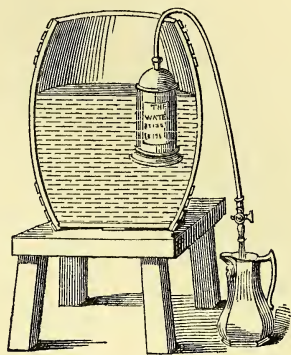

Bird's Syphon Water-purifier.

The Victoria night-light—may be used like candle; it burns twenty hours, and emits no smoke. This night light is shown in the following cut.

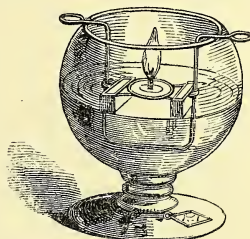

Bird's Victoria Night-light.

268 WINTON & SONS, 53 *Cleveland Street, Birmingham*—
Inventors and Manufacturers.

Spoons, &c., in electro-plate, ivory, and pearl; some of new design. Improved tinned-iron spoons, exhibited for quality, form, and cheapness.

Skewers, ladles, shoe-lifts, &c. Taps, cocks, joints, &c., in brass and other metals.

Tablets and name plates, of new material and manufacture. Freeman's lecture tablet.

269 SMITH, THOMAS HENRY, 20 *Brewer St., Golden Square*—
Designer and Manufacturer.

Stove ornament for the summer season, intended to supersede the use of paper, enclosing the stove, but allowing free ventilation. It can also be used where fire is not required, and made air-tight by the insertion of plate glass.

Design for a centre ornament for a ceiling (forming the star of the Order of the Garter), composed of upwards of five thousand postage stamps.

270 SIMONITE, JOHN, *Pope Street, Birmingham*—
Manufacturer.

Tinned wrought-iron culinary utensils, consisting of soup and vegetable ladle, skimmer, meat fork, peel plate or cake turner, and basting ladle.

Tinned wrought-iron tureen ladle, and water-bowl, or wash-hand basin.

Improved forged japanned wood-handle stove shovel, dust-pan, and cinder-sifter.

Copper parlour coal-shovel. Strong forged kitchen fire shovel. Galvanized iron socket manure bowl.

Wrought-iron melting ladle for plumbers; pitch, or seaming ladle.

Tinned wrought-iron cook's ladles, with flat side, for ship's use.

Japanned iron and galvanized sail thimbles, and ship's hooks and thimbles.

Tinned wrought-iron tinner's furniture, and table and basting spoons.

[This collection of useful articles is manufactured of wrought iron, and is produced by the ordinary methods of hammering, swageing, &c. The three methods are here shown by which such utensils or fittings are preserved, viz., tinning, galvanizing, and japanning. The first process is effected by pickling the iron to be tinned in a weak solution of oil of vitriol, which removes the scales; it is thereafter dipped in sal ammoniac and resin, and immersed in a bath of melted tin, which adheres to and forms a protective coating. The so-called galvanizing process, viz., coating with zinc, is effected in a similar way; the iron is cleansed, and after the same course of proceeding, is immersed in a bath of zinc metal. Japan is applied with a brush, and the article thereafter is stored to dry.—W. C. A.]

271 HICKMAN & CLIVE, 34½ *William Street North, Birmingham*—Manufacturers.

Coffin furniture, consisting of inscription-plates, handles and plates, head, foot, and other ornaments.

Coffin furniture is produced by pressure from thin plates of metal in dies formed of cast iron or steel.

273 SHENSTONE & MILLS, 25 *Mary Ann Street, Birmingham*—Proprietors.

Specimens of polished fire-irons, locks, chest handles, snuffers, percussion caps, &c., as illustrations of cheapness. Embossing presses for stamping receipts and other purposes. Copying presses.

Metallic tokens, checks, address cards, and labels. These metallic tokens and address medals are used by tradesmen as an advertising medium. Vesta and other brass boxes. Samples of embossed and coloured envelopes.

Case of knives and forks, paper knives, &c., with deers' and fawns' feet handles.

274 MOORE, PAUL, & Co., *Great Lister Street, Birmingham*—Manufacturers.

Brass stop butt hinges. Brass hinges for cabinet, building, pianoforte, and ship purposes.

German silver and embossed electro-plated hinges for ornamental articles of furniture, whether of timber or papier maché.

Rolled sheet brass slit, showing process of making plain and embossed wires.

Brass locomotive tube. Brass and cased tube. Brass, copper, and iron wire, round and square. Tinned iron wire. Wire for horticultural purposes.

Rolled brass, latten brass, and brass polished on one side. Pattern brass sash bars.

275 HORNE, THOMAS, *Cleveland Street, Birmingham*—Inventor and Manufacturer.

Collection of hinges for the South-American market, and for general purposes.

276 WOLVERSON, EDWIN, 2 *Ashton Terrace, Birmingham*—Inventor and Manufacturer.

Secure lock, with an improved detector, and a new combination of levers. If the levers are moved by a false key, the new detector is thrown, the bolt becomes immovable, and the combined levers assume a position which renders it impossible to open the lock except with the right key. It is said this lock cannot be picked.

277 JONES, R., & SONS, *Birmingham*—Manufacturers.

Specimens of cork-screws.

278 ROWLEY, CHARLES, *Newhall Street, Birmingham*—Manufacturer.

Patent and registered articles:—Shawl pins, shirt studs, brooches, and dress-fasteners. Livery, naval, and military buttons, showing the devices and shields for officers; also the belt-plates and sword furniture used in the British navy.

Wire-loop brace-buttons and eyelet-holes, which, from their construction, prevents the cutting of the thread by which they are fastened.

Whip and stick handles, with an ever-pointed pencil-case introduced.

[Buttons of this kind are produced by cutting out the blanks from rolled metal; they are concaved by stamp, the eyes are soldered on, they are then cleansed, gilt, and burnished; the impression is given by means of a die attached to a stamp, which completes the manufacture.—W. C. A.]

279 TWIGG, G. & WILLIAM, *Summer Hill, Birmingham*—Manufacturers.

Specimens of buttons, plain, fancy, gilt, plated, for livery, military, naval, and sporting purposes. Glove and brace buttons. Fancy mounted glass and pearl buttons. Steel brooches and buttons. Shirt studs.

Registered fastener for boas, victorines, mantles, garters, &c.; and dress pin fastener, with slide spring, to secure a shield on the point of the pin.

280 WILLIAMS, THOMAS, *Helstone*—Inventor.

Model of an iron safe. The novelty is the introduction of water round every part of the inner case. The construction of the joint for conveying the water to the outside door from the body of the safe is also new.

Model of an axle for a carriage, with box complete, having a hollow perforated arm to the axle which supercedes the wells to the usual oil-boxes; the oil can be supplied quickly at any time, and, from the arm being perforated, the oil is equably used.

281 PIGGOTT & Co., *St. Paul's Square, Birmingham*—Manufacturers.

Specimens of naval, military and livery, plain, fancy gilt, and plated buttons. Glass buttons in great variety. Chased and enamelled studs for shirts, &c. Bronzed sporting and other buttons, suitable for coats. Link and tag buttons, for foreign markets; four-hole metal buttons for trousers. Medals, coat links, gilt and plated fasteners and slides for dresses. Buttons suitable for ladies' and children's dresses.

The naval, military, livery, gilt, plated, and other buttons, are made with the exhibitors' improved riveted and soldered back and shank, which will neither break off nor become loose, and is therefore of great importance for all buttons which are required with fast shanks.

282 HAMMOND, TURNER, & SONS, *Snow Hill, Birmingham*—Manufacturers.

Cases of various descriptions of naval, military, sporting, and club buttons, gilt, plated, bronzed, &c. The sporting buttons in the centre of these cases depict the various national sports of Europe.

The centre button exhibits a bust of Queen Victoria, executed by W. Wyon, R.A., and arranged round it are the sporting buttons before mentioned, on which are portrayed fox hunting, deer stalking, boar hunting, bull fighting, bear hunting, wolf hunting, and chamois hunting. In the squares around, are arranged a variety of chased, enamelled, &c., buttons for vests; and the large figure of a diamond is composed of numerous descriptions of livery, club buttons, &c.

Selection of fancy gilt buttons, suitable for dress coats. Assortment of bronzed sporting buttons, both in simple and fanciful designs. It is usual to have each button of a different pattern to compose a set for a coat; a large number of expensive dies are required to produce a variety.

A complete variety of pearl buttons. This article demands considerable skill and practice on the part of the artizan; and is now one of great importance in the button trade, employing in Birmingham, where they are almost exclusively manufactured, upwards of 2000 pairs of hands.

[The mother-of-pearl shell is, as is generally known, obtained by divers from the bottom of the ocean; and is, in fact, the oyster in which the gems, usually called pearls, are found. The best description of white mother-of-pearl shell, are found in the East Indian and Chinese Seas, and are brought to market chiefly at Manilla, Singapore, and Batavia. The black shell is a peculiar species, found in the waters of the Pacific among the Polynesian islands.]

283 **ASTON, WILLIAM**, *Prinsep Street Works, Birmingham*
—Manufacturer.

Florentine buttons, black and coloured; finished by steam machinery. Improved Florentine buttons, with silk backs. Linen and Holland buttons. Covered buttons, in silk, satin, and various materials, coloured. Upholstery buttons, in leather, horsehair, chintz, moreen, worsted damask, tabaret, and figured satin.

Series, illustrating the manufacture of buttons.

[In the yearly consumption of material arising from the manufacture of covered buttons in a single factory, the subjoined quantities of the various textile and metallic substances are used. In the works, 400 individuals are engaged; they are principally women, assisted by children, skilled workmen being employed to correct the tools and construct the machines. In 1850, were consumed as follows:—

	Yards.
Of 3-4 Florentine lasting	47,865
Lion skin and woollen cloths	162
Vesting fabrics	398
4-4 Irish linen	3,011
Figured velvets and satins.	693
Silks	2,126
Black and coloured satins	1,182
Black and coloured silks and velvets	1,017
Sundries	200
Strong canvas	26,587½
Silk for silk backs	3,579
White linen drill	1,471½
Of best charcoal iron weighing per superficial foot 4 to 5 oz.	514,900 ft.
Of button-board (paste-board)	33,391 lbs

65,000 gross of iron brace-buttons were made from 2 ton of iron, in measure equal to sup. ft. 32,638

23,000 gross were also made from brass and mixtures of copper and plated metal.

In light steel toys, viz., buttons, clasps, and fastenings for ladies' dresses, were consumed upwards of 5 tons of sheet steel.

When the cutting-out of the parts is performed by hand, one-third of the material goes to waste, owing to the circular form of all parts of the button. In this case, however, it is performed by machinery, which effects a very great saving of material. Fifteen machines are employed. They are automatic, and work well.—W. C. A.]

Shell suspender and gaiter buttons, in japanned iron, silvered brass, silver and gold plate; with specimens of patent buttons suitable for great coats. Solid suspender and gaiter buttons, in japanned iron and silvered brass, with holes countersunk on both sides. Japanned iron shell jet and steel buttons. These articles are new, some being a half, and the others an entire ball of hollow steel, cut in various shapes, and polished. Steel dress-fasteners and ornaments, plain and fancy cut.

[The light steel toy-trade, which includes buttons, clasps, fastenings, brooches, &c., and which has been revived with

profit within the last few years, is entitled to a brief note. The articles are cut out from sheet steel; they are curved by a stamp, and perforated by small tools fitted into a press; the small eyes and fittings for attaching pins are soldered on; they are case-hardened, and tempered in oil, the reflecting surfaces being cut into ornamental arrangements by soft metal wheels with emery and oil. They are next fastened on a revolving table, and a hard brush with emery upon it, is worked in a horizontal direction: a finer degree of polish is given with a softer brush and iron-stone powder; final brilliancy is given by putty powder and the palm of the hand. The cutting of these surfaces is a matter of taste, and depends much upon the art of the workman.—W. C. A.]

284 **HARDMAN & ILLIFE**, *38 Newhall Street, Birmingham*
—Manufacturers.

Buttons, medals, hooks and eyes. The buttons include Florentine, silk (hand-made), patent linen, registered coat attachers, gilt and plated dress, military and naval.

285 **NEAL & TONKS**, *13 Great Charles Street, Birmingham*
—Manufacturers.

Real stone and fancy glass buttons, for waistcoats; and for ladies' and children's dresses.

Shirt studs in glass, pearl, ivory, and jet.

Coat loops in stone and fancy glass.

Ladies' glove bands and bracelets.

Horses' bridle rosettes in fancy cut glass.

[Real stone buttons are formed, as their names indicate, from natural substances, cut and polished by the ordinary process of the lapidary. They are drilled with copper tools, revolving rapidly in a lathe fitted for the purpose, and the tool from time to time touched with emery and oil. Fancy glass buttons are made by "pinching." The glass is heated. A pair of pincer-like instruments, with the form of the button sunk in intaglio, is used to give the form, and the process consists in introducing the melted glass, and pressing the two parts together, when a button is produced. In some cases the eye is introduced into the interior of the glass at the time the button is made; in others, a hole is pinched in the button, the eye introduced, and rivetted with a small collar on the surface, which adds to the ornamental appearance of the fastening. Other varieties of glass buttons are made by taking sheets of coloured glass, the back of which has been "quickenened" (coated with lead), in the manner of silvering, cutting it into small squares, equal to the diameter of the button; the corners are taken off by clipping. The back of this variety is formed of metal, cut out in the manner of "blanks," to which the eye is soldered by hard solder; the glass is heated, the "quickenening" melted, the metal back also being tinned and heated, the two parts are placed together, and a junction is effected by the ordinary adhesive properties of the solder. The button is finished by grinding the edges, surfaces, &c., and like cuttings are given by the ordinary glass cutting and polishing process. Glass rosettes, for saddling purposes, are produced in the same way. The two colours are given by cutting through the coating of coloured glass to the colourless flint glass, which forms the foundation.—W. C. A.]

286 **CHATWIN, J., & SONS**, *92 & 93 Great Charles Street, Birmingham*—Manufacturers.

Samples of buttons—silk, fancy, and plain; patent braided edge, rich velvet, &c., with specimens illustrative of the process of making. By this process a covered silk button, with a strong woven braid or edging, is made with less than half the silk formerly required. A selection of fancy, gilt, patent electro-plated, and patent linen buttons.

Upholsterers' and coachmakers' nails for furniture, covered in the same way as covered buttons. A selection of black and white pearl buttons; bronze, fancy glass, and Cox's patent horn buttons.

287 BANKS, EDWARD, *Birmingham*—Manufacturer.

Mother-of-pearl shells used in the manufacture of buttons. Mother-of-pearl buttons, for ladies' dresses, gentlemen's overcoats, coats, vests, shirts, &c. The material is from the Gulf of Persia and other places, including the Sooloo Islands, the shores of which afford the largest and finest yet discovered.

288 FREARSON, JOHN, *Gas Street, Birmingham*—Proprietor and Manufacturer.

Hooks and eyes to fasten ladies' dresses, &c.

289 KNOWLES, H., *Howard Street, Birmingham*—Manufacturer.

Gold-plated enamelled buttons.

290 WELLS, J. T., *Birmingham*—Manufacturer.

Patent horn-buttons.

290A LONG, JOSEPH & JAMES, & Co., 20 *Little Tower Street*—Inventors and Patentees.

Patent curvilinear window blind pulley, by which the cord can be regulated to its proper point of tension, without its slipping back or being strained too tight.

291 PHILLIPS, HENRY, 116 *Unitt Street, Birmingham*—Manufacturer.

Gold and silver guard chains, brooches, bracelets, &c.

292 SHELDON, J., 55 *Great Hampton Street, Birmingham*, and 33 *Bucklersbury, London*—Inventor and Manufacturer.

Gold ever-pointed pencils, with solid gold mounts, set with real stones, and ornamented with varieties of rose engine-turning, engraving, and chasing.

Gold ever-pointed pencilcase, engraved with Her Majesty's arms quartered with H.R.H. Prince Albert's, the top of the pencil surmounted with the royal crown, set with ruby; this case contains an ever-pointed pencil, penholder, toothpick, half-sovereign gauge, a letter and coin balance.

This pencilcase, with its various combinations, is represented in the following illustrations.

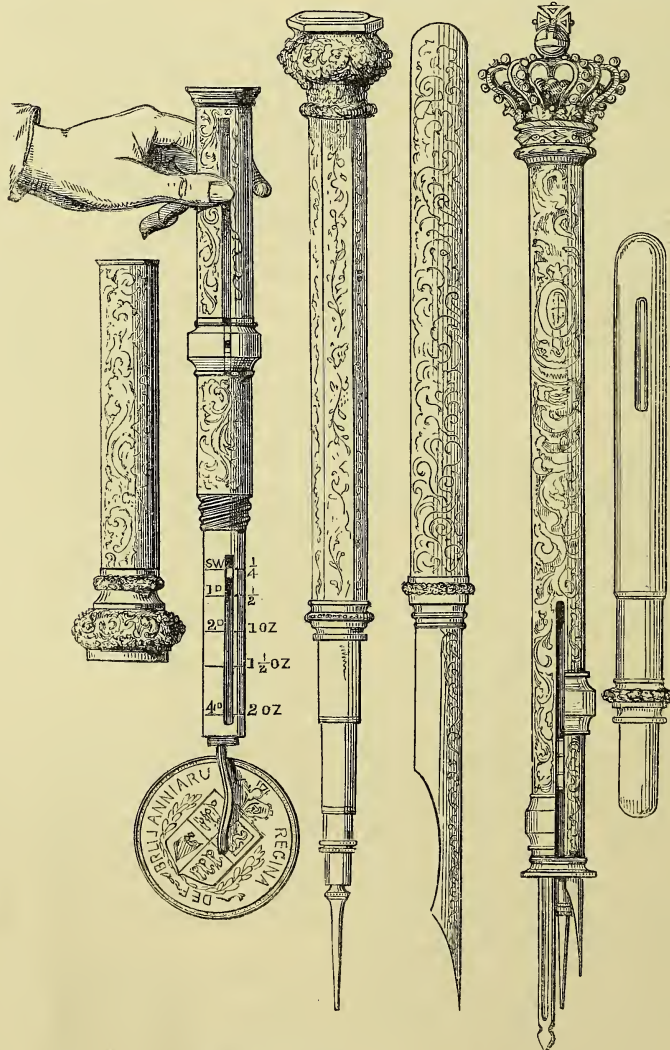

Sheldon's Gold Everpointed Pencilcases.

Gold pens, union gold and silver pens, and silver pens with iridium points, a metal so hard that ten years' constant use is said not to produce any sensible wear; penholders of silver and gold, with an ever-pointed pencil, &c.

Similar articles in silver, electro-plated, and nickel silver of various styles, with balances accurately graduated for various scales of postage, coins, &c.

The fountain music-writer, in electro-plated and nickel silver, for making crotchet or quaver dots with speed, uniformity, and accuracy; with a penholder.

Royal Albert pocket requisites, an ever-pointed pencil, penholder, and penknife, in silver and electro-plated.

Silver single and double spiral ever-pointed pencils; elongating or telescope pen and pencil; and sliding pencils. German silver ever-pointed pencils and pencases.

Penholders in silver and electro-plate, mounted on ebony, ivory, pearl, and porcupine-quill handles.

Pocket escritaires, made of a metallic body covered with leather, containing a letter balance, with penholder, inkstand, steel pens, and other useful articles.

Electro-plated and nickel-silver spoons, forks, ladles, butter-knives, fish-carvers, sugar-tongs, meat-skewers, &c., in plain, fiddle, threaded, and Victoria patterns.

Electro-plated and nickel-silver snuff, tobacco, and pipe-boxes, pipe-cases, &c. Silver, electro-plated, and nickel-silver fusee-boxes. Brass and japanned pipe and tobacco-boxes, and tobacco pipe-cases, &c., in various styles.

[The class of articles here described exhibits one of the peculiarities of the Birmingham trade, viz., the variety of different manipulating operations carried on at one manufactory, and the attempt to adapt the articles produced to a great variety of different purposes. Pocket escritaires, containing within the size of an ordinary pocket-book all the materials for correspondence, pens, ink, paper, wafers, &c., present a curious contrast with the same class of articles in use a few years ago. The introduction of German silver has materially facilitated the production of the smaller class of articles, such as pencilcases, penholders, &c. Pencilcases are formed of mandril-drawn tubes, that is, tubes which are drawn through a steel hole, and their external diameter supported by a steel mandril. This is cut to the necessary length, and adorned externally by engine-turning or some other process. In ever-pointed pencilcases (which have now almost entirely superseded the older kind), the fitting of the magazine at the top, the combination which produces the ever-pointed action, gives employment to many artisans.—W. C. A.]

293 ALLEN, F., *Birmingham*—Manufacturer.

Silver and gilt filigree work.

294 GOODE & BOLAND, *24 St. Paul's Square, Birmingham*—Manufacturers.

Patterns of guard-chains, bracelets, Albert chains, necklaces, brooches, and rings.

Specimens of jewellery, chains, &c., manufactured from the raw material.

Samples in the rough and subsequent stages.

Specimens of blood-stone, slit by a self-acting machine.

[Slitting of stones is effected by means of a disc of soft iron called a slicer, which revolves very rapidly, and is occasionally touched with diamond-dust. This exhibits the paradox of a soft substance cutting a hard one. A steel file is readily cut by a soft metal disc.—W. C. A.]

295 SMITH, KEMP, & WRIGHT, *165 Brierly Street West, Birmingham*—Manufacturers.

Buttons of gold, silver, copper, brass, iron, tin, lead, zinc, steel, glass, wood, bone, papier-maché, brass gilt by mercury and electricity, enamelled, silvered, lacquered, bronzed, and japanned, black mother-of-pearl shell, white mother-of-pearl shell, green ear shell, and green snail shell.

Registered shirt studs, gold, silver, gilt, pearl chased, enamelled, and engraved; also composed in different pro-

portions of most of the materials enumerated and designated run-buttons, being made of several pieces as concentric rings, so fastened and held together as to form one button.

[The old method of gilding is distinguished from the electro process, by the gold used in the operation being reduced to an amalgam by means of mercury, which readily unites with the gold, and forms the gilding mixture. The buttons to be gilt are placed in a pan, some of the amalgam introduced, and sufficient nitric acid being sprinkled upon them in order to remove any extra oxidation; the acid, and lastly the amalgam, is diffused over the whole of the metal to be gilt, and the fumes of the mercury are evaporated by heat.—W. C. A.]

296 WALTERS & STONE, *28 Ludgate Hill, Birmingham*—Manufacturers.

Lady's mausoleum ornament. Black ornaments, as brooches, &c.

Chatelaine, brilliantly set, containing devices, &c., formed with human hair. Human hair worked as bracelets, &c.

Ladies' brilliant finger-rings, each forming a finger-ring and an armlet. Brilliant, mounted as a gentleman's finger-ring, pin, and stud. Mounted medals.

297 BIDDLE, JOHN, *23 Victoria Street, Birmingham*—Manufacturer.

Seals, penholders, letter-clips, book-clasps, and mountings.

298 PARKER & ACOTT, *54 Brierly Street West, Birmingham*—Manufacturers.

Good and silver pencils and penholders, of various kinds. Gold tooth-picks, seals, and keys.

299 BALENY, J., *Birmingham*—Manufacturer.

Specimens of gold and plated jewellery. Gilt ornaments and toys. Black ornaments. Steel, steel gilt, and other spectacles.

Cenotaph under a glass shade, "to the late Sir Robert Peel," exhibited as a specimen of workmanship in the black ornament trade.

300 ALLEN & MOORE, *35 & 36 Great Hampton Row, Birmingham*—Designers and Manufacturers.

Vesta match-boxes; cigar boxes. Taper-stands and lamps; and other fancy articles in metal.

Case of medals:—Head of Prince Albert, and view of the Exhibition building. Duke of Cambridge, and Governesses' Asylum. Frederick Von Schiller. Jenny Lind. Cavaignac. Louis Napoleon. Heads, from Da Vinci, Scheffer, &c.

Metal buttons:—Naval, military, livery, sporting, fancy, four-hole, and glove buttons.

[Vesta Boxes, Medals, and Medal Making.—A new branch of manufacture has been called into existence by the introduction of the lucifer-match. The square paper and the round timber box have given place to an elegant metallic case used for the purpose of containing the "Vesta matches." The mode of production may be thus described:—a mandril-drawn tube is taken and cut into lengths in a lathe; a portion is turned down or reduced to fit the lid; this is reversed, and the end with its rough surface against which the match is to be rubbed in order to procure a light, is checked, in. The portion of tube which forms the lid is now taken, placed upon a chuck, and the head or cover is checked in, after the manner of the bottom. For certain varieties, a small socket is used to hold the taper, which is nutted into the lid; other varieties are fitted with springs, into which the match is stuck, the simple attempt at removal producing ignition. The ornamentation is effected by coating the brass with a

transparent varnish or lacquer of various colours, which is cut through in a series of lines, displaying floral or scroll devices by means of an embossing machine. This machine somewhat resembles a pantograph;—a cylinder of steel upon which the pattern is engraved is placed so as to act against the end of a long rod, the other extremity of which cuts away the lacquer on the brass box. Thus in an ingenious manner the pattern on the steel cylinder is reproduced upon the match box. Cigar-cases and taper-stands, with magazines or receptacles to hold matches, cigars, and tapers, are now produced in immense numbers by the same process of manufacture.

The Industrial Exhibition of 1851 has called into requisition, among others, the skilled labour of the medallist die-sinker. As a consequence, medals of all kinds and prices are being produced. A medal die is thus formed:—Steel of a uniform texture and suitable kind being selected, it is forged, softened by annealing, and the face and check for the collar turned. The design approved of, the die-sinker proceeds to cut away those parts of the greatest depth by means of small chisels: the more minute details are taken out by gravers, chisel-edged, and gauged steel tools fitted into wood handles, very short, and to fit the palm of the hand. As the work proceeds, proofs are taken in wax: when defective in form, the cutting is corrected, and if deficient in relief, it is sunk deeper. It will, of course, be borne in mind that what will be relieve in the medal is intaglio in the dye. The inscription is introduced by means of small letter-punches. Then follows the hardening of the die, a stage of the business the most critical, as a defect in the steel will at once be made apparent thereby, and the labour of months rendered useless in a few minutes. If the die endures this, it has only another test, viz., the making of a “hub,” or copy of the die in steel, and used for the correction of duplicate copies of the die. The danger in this case arises from the want of uniformity of hardness. If irregular, one portion of the original die must suffer, and becomes valueless.

Medal-making or stamping is thus carried on:—The press consists of a large and close-threaded screw, to the top of which a large wheel is attached horizontally. The bed of the press is fitted with screws to secure the die in its place; when this is done, the collar which gives the thickness of the medal is fitted on, the die forming the reverse of the medal is attached to the screw; a blank (a piece of metal cut out to form the medal) is then introduced. Motion is imparted to the wheel which operates upon the screw, a blow is given, and if the impression is soft and shallow, a medal is produced; but if deep, repeated blows are given to bring the impression up. Where bronze or silver is the material in which the medal is to be produced, as many as 20 or even 30 blows are necessary. The medal is then taken out of the press, the edge turned, and the operation is complete.—W. C. A.]

301 ASTON, J., 20 *St. Paul's Square, Birmingham*—
Manufacturer.

Ornamental silk, satin, and velvet buttons, dress ornaments, and patent linen buttons.

302 ELLIOTT, WILLIAM, & SONS, *Regent Street Works, Birmingham*—Manufacturers.

An assortment of fancy buttons for ladies' dresses.

Specimens of gilt, plated, military, naval, sporting, crest, and ball buttons.

Patent silk, velvet, satin, Florentine, and patent Irish linen buttons.

Pearl buttons with metallic rims.

303 AVERN, E., 72 *Newhall Street, Birmingham*—
Manufacturer.

Patent improved shoe-scraper.

304 INGRAM, T. WELL, 85 *Bradford Street, Birmingham*—
Designer and Manufacturer.

Specimens of horn buttons, illustrating the manufacture prior to the patent, and the improvements made since; also materials from which they are made.

[The ornamental surface is given by pressure in a die when the horn has been softened by heat.—W. C. A.]

305 HEELEY, JAMES, & SONS, *Mount Street, Birmingham*—
Manufacturers.

Chatelaines, with various appendages. Sword hilts for dress swords. Latchets. Court and other buttons. Snuffers. Patent revolving stirrups. Cork-screws. Boot-hooks. Key-rings. Tweezers. Swivels. Netting-vices. Bracelets. Brooches. Shawl-pins. Waist-buckles. Purse-mounts. Slides and tassels. Albert chains and keys. Watch-guards. Various keys. Invalid tongs. Purses and various trinkets.

[Steel buckles, formerly much used, as well as buttons, purses, clasps, keys, rings, and chains, were manufactured in great quantities at Birmingham. Some idea may be formed of the complexity of pattern in buttons, when it is stated that as many as three hundred ornamental headed studs have been counted on a single button. Steel guard chains have, of late years, been introduced with success; the links of these are cut out by the press, and pierced by the same instrument; they are then case-hardened and polished.—W. C. A.]

306 OTTLEY, THOMAS, 122 *Snow Hill, Birmingham*—
Designer and Manufacturer.

Gold, silver, and bronze prize medals, including agricultural, horticultural, botanical, and school medals; also, historical and other medals.

[The art of die-sinking in England has its centre in Birmingham, and has reached a degree of unparalleled perfection and of immense importance. The art is of so peculiar a character, and requires so much nicety and so large an experience in tool-craft, that it employs, in the higher departments, comparatively a small number of workmen, but in the commoner, a large number are constantly occupied. Medallists have always ranked highly among the die-sinkers of Birmingham; and the Soho works, in addition to a large production of medals, were for a considerable period the mint for the copper coinage of the United Kingdom. At present, the medallists of Birmingham are in full occupation for the preparation of medals for prizes, and in commemoration of great occasions. The medals thus produced are extensively demanded at home, and have also an extraordinary circulation on the Continent, and in distant parts of the world.—R. E.]

307 COTTERILL, EDWIN, 101 *Henry Street, Ashted, near Birmingham*—Inventor and Manufacturer.

Patent climax detector locks, made to the keys; and from the peculiar construction of the machine by which the keys are made, two locks cannot be made alike, unless formed from the keys cut at the same time. They can be made to shoot any number of bolts both ways.

309 EYKYN & MILLICHAP, 50 *George Street, Parade, Birmingham*—Inventors, Patentees, and Manufacturers.

Carriage axles on the Collinge principle, with patent safety and other improvements.

[These improvements consist in the application of a thread, which traverses the back of the axle near the collar; a corresponding hollow thread is cast on the bush; after the bush has passed these threads a flat is left, on which it traverses or revolves. This arrangement effectually secures the wheel against removal.—W. C. A.]

Collinge axle without the improvements.

An axle; patent axle arms on the mail principle.

310 NASH, RICHARD, 20 *Russell Street, Birmingham*—Proprietor.

Dies and small tools. Spoon and collar dies. Medal dies, and collar, coin, and office-seal dies. Button and shank-hole dies.

[Much of the Birmingham jewellery and gilt toys are produced by means of dies or steel blocks, with impressions of articles to be sunk therein. Ear-rings, brooches, bracelet-fastenings, have their ornamental features impressed in this way; they are then filled up or joined together, if made in parts.

By "collar die" is meant that portion which gives the thickness of the medal or coin to be struck. All medal dies are in three parts, viz., the reverse, obverse, and collar. The smaller class of dies are cut in steel entirely, the larger kinds, for brass-foundry and other purposes, are "laid" or covered with steel on a foundation of iron. When indentations occur, the die is what is called "fullered" or hollowed, and the steel follows the same in a parallel thickness.—W. C. A.]

311 JACKSON, W., *Birmingham*—Manufacturer.

Anvil for planishing tin plate. Hammers assorted for tin and copper work. Creas-iron, or wiring stake, for tin. General swage, to hold different tools for beading tin. Bick-iron, for tin plate, and side stake, for tin or copper work.

Bottom stake, for planishing copper. Pair of stock shears and hand shears, for cutting tin, copper, &c.

Model of a raising machine, for raising dish covers, 1½ inch in scale.

[Many of the requisites for the tin-plate making are enumerated in the above collection of articles, and though "raising" by means of "spinning" and stamping has to a great extent superseded the older methods of tin-plate working, the polished anvil, stakes, or beak-iron, with their corresponding planished-faced hammers of various forms, cannot yet be dispensed with. In the new mode of production, seam-soldering is entirely avoided. "Spinning" imparts to tin goods a considerable degree of firmness and solidity with denseness of texture. Moulding is still necessary in the manufacture of certain articles; to effect this, stakes, anvils, and swages must be put in requisition. Dish-covers were originally formed by hammering out of flat sheets of metal; many of them here are raised by the stamp, and present a brilliant polish. Tin-plate making, and tool making for the same, give employment to hundreds of artisans in and around Birmingham.—W. C. A.]

312 TIMMINS, RICHARD, & SONS, *Pershore Street, Birmingham*—Manufacturers.

Specimens of carpenters' hammer heads, and handled hammers. Carpenters' and farriers' tools. Shoemakers' tools. Timber scribes, hand and table vices, and improved coach wrenches. Saddlers' and upholsterers' tools. Various household and other utensils.

313 MANLY, JOHN, jun., 55 *Bread Street, Birmingham*—Patentee and Manufacturer.

Patent ornamental nails, bronze, silvered, gilt, lacquered, and covered, principally intended for attaching

the covering materials to furniture, &c. They can be made of various colours and materials at small cost.

314 TYE, GEORGE PIERCY, *Snow Hill, Birmingham*—Inventor.

Specimens of registered root-glasses, with stands and supports, containing wax models of hyacinths, to show the use of the flower support.

Glasses and stands. Registered spring labels for tree and flower-pots.

315 REYNOLDS, JOHN, *Crown Nail Works, Newton Row, Birmingham*—Manufacturer.

A case enclosing a card of cut nails, consisting of upwards of two hundred distinct varieties of the most useful strengths and sizes; made of iron, zinc, brass, and copper.

[In this manufacture, sheets of iron, of the proper thickness, are cut across by a pair of cutting edges which are set in motion by machinery; the breadth of these strips is equivalent to the length of the nails to be produced from them; the strip, for the convenience of turning, is fastened into a pair of grips attached to a wood shank, resting, when in use, upon a support immediately behind the workmen. The nail machine consists, essentially, of a pair of cutting-chisels or edges, which work perpendicularly, parallel to each other; a gauge to determine the breadth of nail; a pair of grips, into which at the time the wedge of iron falls, and where it is firmly held, until the small horizontal hammer strikes it and produces the head, when it is dropped into a box beneath. Brads are not headed, but are simply cut out of each other, that is to say, a deficiency in the parallelism of the cutting-edge produces the head, and prepares for the head of the next brad to be cut therefrom. Glaziers' brads being simple wedge-like pieces of iron, without any head whatever, are produced by the simple operations of the chisels or cutters. When tacks are blued, they are done in quantities, by exposing them to heat in an oven or muffle, or upon an iron plate. Japanning is performed by the ordinary process.—W. C. A.]

316 HENN & BRADLEY, *Cheapside, Birmingham*—Manufacturers.

Taper wood screws in iron, brass, and copper; iron thread screws for machinery of every description, and for stoves, grates, &c.

Taper hand-rail screws, adapted for pianoforte-makers, and fine cabinet work.

[Screw-making:—Operation 1. From a coil of wire placed on a wheel and introduced into the screw-making machine, a piece, sufficient to form a screw is cut off, caught up, and headed; that is to say, the portion which forms the head is compressed into shape, and the now-called "blank" is dropt into a receptacle below. Operation 2, consists in flattening the head and smoothing the countersink, which is performed by the "blank," being held in both clams, and having a small cutter revolving in front and another behind. 3. Slitting the head; the "blank" is placed in a pair of nippers, which is moveable on centres by means of a lever action, the head is pressed against a small revolving circular saw, and the slit made. 4. Threading is effected by the "blank" being introduced into a pair of clams which is attached to a spindle, the back part of which is cut with a worm or thread corresponding to that of the screw to be cut, and which propels forward the clams and the "blank" against small-toothed cutters, which groove out the thread; three runnings down is sufficient to complete the manufacture of an ordinary sized screw. The difference in the finest threads arises from the shape of the cutters.—W. C. A.]

317 JAMES, JOHN, *Redditch, near Bromsgrove*—
Manufacturer.

Specimens of needles and fish-hooks. Needle-boxes, furnished. Needles and fish-hooks in the various processes of manufacture.

318 HAWKINS, JOHN, *22 Prinsep Street, Birmingham*—
Manufacturer.

Wood screws in iron, brass, and copper; railway, coach, and grate, machine screws, and bolts.

319 BAKER, GEORGE, & Co., *68 Cecil Street, Birmingham*—
Wireworkers and Manufacturers.

Fire-guards and window-blinds. House and stable lanterns. Rushlight guard. Nursery lamp. Candle shade. Fruit-basket; lady's work-basket. Dish and plate covers. Letter rack. Sir Humphrey Davy's lamp. Parrot and other bird cages. Squirrel-cage. Flower-pot stands. Mattress springs. Patent iron and brass chain, made by machinery, with varieties electro-plated and bronzed. Specimens of weaving in iron and brass wire. Peg lattice and hare fence. Dome-top electro-plate twisted fire guard.

320 COOKSEY, HECTOR RICH., *148 High Street, Bordsley, near Birmingham*—Manufacturer.

Specimens of coffin furniture, in plated gold and silver, and brass and tin japanned.

321 SIMCOX, PEMBERTON, & SONS, *Birmingham*—
Manufacturers.

Patent curtain decorations; curtain bands and cornice pole ends.

Furniture for mortice locks in brass, glass, china, white and gilt opal, with metal mountings gilt and electro plated.

Finger plates, bell pulls, and bell levers. Lacquered and bronzed finger-plates.

Outside bell-pulls, hall-door knobs, bell slides, in the Gothic, Elizabethan, and other styles.

Registered door-knockers and chains. Registered and other letter-box plates.

Gothic and Elizabethan work for churches, consisting of hinges, lock-handles, escutcheons, &c.

Letter clips, letter balances, date tellers, office and table bells, and wax taper stands.

Sconces of various designs for pianofortes, pictures, looking glasses, pulpits, wall brackets, &c.

Plain and wrought coat and hat hooks. Blind mountings. Door porters and folding fire screen brackets.

Registered and other casement stays, espagnolettes and sash fastenings.

Bell carriages, cranks, and general bell-hanging work.

Registered stair and curtain rods; miniature and picture frames.

Registered and other rack pulleys, tassel hooks, roller blind ends, table catches and fasteners. Butt, and other hinges.

Socket, flush, ship, and other bolts; cabin-door hooks.

Round, square, plate, and socket and claw castor for pianofortes, sofas, tables, chairs, &c. Lamp and screw pulleys.

Shop-door handles, in china, glass, opal, brass, &c.

[These contributions form illustrations of what is technically known as cabinet and general brass-foundry. The application of china, and more particularly glass, is now very extensive. The introduction of the brass collar to the china mortice knob, of stamped brass-foundry in the form of drapery and rope work for upholstery purposes; and of an ingeniously-constructed blind mounting, which causes the blind to ascend, instead of descend, is due to these exhibitors.—W. C. A.]

322 CORNFORTH, JOHN, *Berkeley Street Wire Mills, Birmingham*—Manufacturer.

Specimens illustrative of the manufacture of iron and other wires:—

A piece of iron, which has been rolled hot into its present form, and which is now called a wire-rod. A draw-plate of steel, through which part of this wire-rod has been drawn. The part of this wire-rod which has passed through the draw-plate, and is now a piece of iron-wire. By a repetition of this process, iron-wire of any diameter may be made. In the specimen, the diameter of the wire-rod has been reduced $\frac{1}{50}$ of an inch by one process; if repeated fifty times, it would give a wire $\frac{1}{1000}$ of an inch diameter. Pieces of iron-wire illustrative of this process, from $\frac{1}{4}$ to $\frac{1}{1000}$ inch diameter.

Piece of telegraph wire, of charcoal-iron, galvanised, drawn from one entire piece of iron; it is 336 lbs. weight, and a mile long.

Piece of charcoal wire; being a portion of that used in the construction of a suspension-bridge near the falls of Niagara; this iron-wire is used for wire-ropes and general engineering purposes.

Steel-wire, of various sizes and qualities. Specimens of soft and hard tinned wire. Coppered iron-wire. Iron and steel wire.

Wire nails of various sizes and forms. Heads and points of nails manufactured by the patent process known as the Pont de Paris, and used by the carpenters of that city, and of France generally, which may be made of any form.

323 POTTS, WILLIAM, *16 Easy Row, Birmingham*—
Manufacturer, and, in part, Designer.

Ornamental bronzed and lacquered gas lamps.



Potts' Ornamental Gas Bracket.

An ornamental gas bracket and globe. This gas-bracket is represented in the above illustration. A helmeted head forms the support of the globe and burner.

Chandeliers, lobby lamps, hall lanterns, &c.

Candelabra, girandoles, ink and flower stands, and various other articles.

Bronze ornament—eagle resting with its prey on a rock.

Grand boudoir, glass frame, bronzed—two naiads are seated to attire themselves, two herons supporting pastile burners.

Single-figure and triple-figure epergne, &c.

Specimens of Potts' patent picture-supporting moulding. Its advantages are, strength, continuous line as a moulding; adaptability for mitreing at any angle; the hook can be attached on and slide along the back of the iron rail; a variety of designs and modes of finish can be obtained, the hook being in its attachment a segment of a circle, moves round the back curve of the rail, so as to be put on and taken off at any point.

Bronze clock-stands—the Chinese dragon.

Fire-screen stand, adaptable also for a chess-table, music-stand, or reading easel.

Pair of heron girandoles. Boudoir candlestick.

Tazza or epergne—the crocodile.

Flower stand. Mirror frame.

324 GILLOTT, JOSEPH, *Victoria Works, Birmingham*—
Inventor and Manufacturer.

Specimens of metallic pens.

[Steel-pen making may be briefly described as follows: The steel is procured from Sheffield; it is cut into strips, and the scales removed by immersion in pickle, composed of dilute sulphuric acid. It is passed through rollers, by which it is reduced to the necessary thickness; it is then in a condition to be made into pens, and is for this purpose passed into the hands of a girl, who is seated at a press, and who, by means of a bed and a punch corresponding, speedily cuts out the blank. The next stage is piercing the hole which terminates the slit, and removing any superfluous steel likely to interfere with the elasticity of the pen; at this stage they are annealed in quantities in a muffle, after which, by means of a small stamp, the maker's name is impressed upon them. Up to this stage the future pen is a flat piece of steel; it is then transferred to another class of workers, who, by means of the press, make it concave, if a nib, and form the barrel, if a barrel pen. Hardening is the next process: to effect this a number of pens are placed in a small iron box and introduced into a muffle; after they become of a uniform deep red, they are plunged into oil; the oil adhering is removed by agitation in a circular tin barrel. The process of tempering succeeds; and, finally, the whole are placed in a revolving cylinder with sand, pounded crucible, or other cutting substance, which finally brightens them to the natural colour of the material. The nib is ground with great rapidity by a girl who picks it up, places it into a pair of suitable plyers, and finishes it with a single touch on a small emery wheel. The pen is now in a condition to receive the slit, and this is also done by means of a press; a chisel or wedge, with a flat side, is fixed to the bed of the press, the descending screw has a corresponding chisel or cutter, which passes down with the minutest accuracy: the slit is made; and the pen is completed. The last stage is the colouring, brown or blue; this is done by introducing the new pens into a revolving metal cylinder, under which is a charcoal stove, and watching narrowly when the colour desired is arrived at. The brilliancy is imparted by means of lac dissolved in naphtha; the pens are immersed in this, and dried by heat. Then follow the counting and selecting. Women are mostly employed in the manufacture, with skilled workmen to repair and set the tools. This exhibitor employs upwards of five hundred hands, of which four-

fifths are women. The manufactory has been established upwards of thirty years, and has been the means of introducing many improvements in the manufacture.—
W. C. A.]

325 WILEY, W. E., & Co., *34 Great Hampton Street, Birmingham*—Manufacturers.

Specimens of gold, palladium, gold and silver, and silver pens, pointed with the native alloys of iridium and osmium, the hardest of known metals.

[These pens being formed of metals not acted on by the ink, appear almost indestructible; their permanence in use is further maintained by the attachment to the point, by soldering, of a minute portion of the metals named, which are extremely hard and durable.—
W. C. A.]

326 HINCKS, WELLS, & Co., *Buckingham Street, Birmingham*—Manufacturers.

Patent self-acting cutting, piercing, and raising-pen machine. The ordinary presses are worked by hand. The self-acting machines are driven by steam; they cut, pierce, and side-slit two pens at one stroke, performing six processes at once.

Specimens of Lilliputian pens complete, intended to show the skill of the tool cutter and the perfection of the machinery employed. A gross of the smallest weighs less than 34 grains, and can be contained in a Barcelona nutshell.

Specimens of finished pens.

Steel in its rough state, and after it has passed through the rolling-mill; scrap-steel, from which the pens are cut; pens, cut and pierced. The other processes exhibited in the finished pen.

Specimens of pierced pens to show the modern improvements in the art of tool-cutting.

327 KELL, A., & Co., *28 Summer Row, Birmingham*—
Manufacturers.

Steel pens; showing their different forms and qualities, with improvements lately introduced.

328 MITCHELL, WILLIAM, *6 St. Paul's Square, Birmingham*—Manufacturer.

Metallic pens and penholders.

329 BARTLEET, W., & SONS, *Redditch, near Birmingham, and 37 Gresham Street, City*—Manufacturers.

Needles of every description, with the most important stages in the process of manufacture, from the wire up to the finished state.

Fish-hooks, of every description, for sea, river, or lake fishing, with specimens exhibiting the different stages in the process of manufacture.

[Fishing hooks are formed by simple tools: a bundle of wire is cut into lengths, and straightened; the barb is formed by a simple blow with a chisel; the opposite end is flattened—the barbed end pointed; they are then case-hardened, the surface being partly acted on and rendered extremely hard, by means of immersion in hot animal charcoal, they are subsequently brightened by friction, and tempered; in some cases they are japanned, in others tinned, but this refers only to the larger sizes.—
W. C. A.]

330 BOULTON, WILLIAM, & SON, *Redditch, near Birmingham*—Manufacturers.

Needles—sewing, netting, knitting, tambour, crochet, rug or carpet, and chenille.

Steel meshes. Surgeons' needles. Stay, mattress, upholsterers', sail, and packing needles.

Sail hooks. Bodkins and needles in fancy-work. Harpoons used in whale-fishing.

Spears used in whale, shark, and dolphin fishing. Large sea fish-hooks. Hooks for fresh-water fishing.

331 HEMMING, HENRY, *Redditch, near Worcester*—
Manufacturer.

A general assortment of sea and river fish-hooks, adapted for the taking of all kinds of fish.

332 NICKLIN & SNEATH, 57 *Bradford Street, Birmingham*—Manufacturers.

Copper, brass, and iron weaving, of various meshes, from 64 holes to the square inch, or 8 mesh, to 22,500 holes to square inch, or 150 mesh.

Fine drawn brass and copper wire; copper wire drawn from a penny piece.

Strong iron weaving, for kiln floors, smut machines, &c.

Brass wire cloth with seams, as used for paper machines, in the manufacture of paper.

[The extreme ductility of brass is shown in the manufacture of wire. A mass weighing 15 grains has been drawn into 181 yards. It is drawn by hand through metal holes or plates, soap being used to lubricate the wire, in order to prevent adhesion, and to give it a finished and smooth surface.—W. C. A.]

332A MARTIN & GRAY, *Berkeley Street, Birmingham, and 14 Gough Square, Fleet Street*—Manufacturers.

Gas chandelier, finished in gold colour and "artistic bronze." Pattern, finished in artistic bronze and gold colour, relief. Gas brackets.

Two chariot lamps; one britzka lamp; newly-invented registered lamps for the interior of carriages, &c.

Mantel and centre vase lights for gas.

Candle lamps, hanging lamps, and hand lanterns.

Toilet furniture, and coal vase, japanned.

["Artistic bronze" is not as may be supposed, either produced by an acid, or by oxidation; it is simply a mixture of colour ground up in turpentine varnish; its depth, or lightness of shade, being regulated by the addition of the blue or yellow colour in use. It is applied by a brush, and the powder bronze is touched upon the projecting parts.—W. C. A.]

333 MORRALL, ABEL, *Studley Works, Warwickshire*—
Inventor and Manufacturer.

Specimens of needles. Knitting pins. Polished steel, gilt, plated, and steel bodkins. Pattern card of needles in the different states of manufacture.

Specimens of machinery for making needles:—Stamp press, or eyeing machine; filing, edding, and curing machines.

[Needle-making may be thus described:—The steel wire is cut into lengths sufficient to make two needles; these are collected into bundles, and straightened by a peculiar process; the grinder takes a number of these pieces in his hand, and causing them to rotate on a grindstone, points them; he next reverses the ends and effects the same result; they are then cut in two, flattened on the end, and eye-punched either by children or machinery; the roughness is removed, the eye smoothed by filing. They are then tempered in quantities, and polished by being gathered together and made to traverse a horizontal hearth or table, some abrasive substance lubricated with oil being introduced amongst them: scouring, winnowing, and sorting then follow.—W. C. A.]

334 HORSFALL, JAMES, *Oxford Street, Birmingham*—
Manufacturer and Proprietor.

Highly finished steel wire, for pianofortes and other musical instruments.

Annealed wire, used as an under covering of the "new patent brass strings," for pianofortes.

Plated, japanned, and self-coloured hitch, bridge, and other pins.

Single, double, and treble spun bass strings, for pianofortes.

Hand and mill-drawn steel wire, for the manufacture of needles, fish-hooks, &c.

[The term self-coloured indicates the colour assumed by steel when brought to certain heats, either a straw or blue colour. Hitch pins are what the strings are hitched or hung upon; bridge pins are those placed on the wooden bridge, from which the strings commence vibrating; globe, ball, and cone key pins are pins with variously-shaped heads, going through the centre and front of the key, to keep them in their places. Wreast pins are the pins on which the strings are wound in tuning.—H. E. D.]

335 GOODMAN, GEORGE, *Caroline Street, Birmingham*—
Manufacturer.

Patent elastic fine-pointed pins, black, purple, and dress.

Specimens of the various sizes of brass pins, and of needles.

336 EDELSTEN & WILLIAMS, *New Hall Works, Birmingham*—Manufacturers.

Pins: the heads and shafts being formed of one solid piece of metal, in order to render the head immoveable and smooth in use; made by improved machinery.

Model dies to show the formation of the head.

Elastic hair-pins.

Specimens of iron wire in various sizes.

[In pin-making the wire is brass (a compound of copper and zinc): it is reduced by the ordinary process of wire-drawing to the requisite thickness; in this process it is necessarily curved. To remove this it is re-wound, and pulled through between a number of pins arranged at the draw, or straightening bench; it is then cut into convenient lengths for removal, and finally reduced to just such a length as will make two pins. The pointing is done upon steel mills (revolving wheels), the circumference of which is cut with teeth, the one fine, the other coarse. Thirty or forty lengths are picked up at once, and, as in needle-making, the cast of hand given by the workman makes them revolve, and the whole are pointed at once; the same operation is performed with the other end. The process of heading is next effected as follows: a number of the pointed wires, now cut in two, are placed in the feeder of the machine; one drops in, is firmly seized, and, by means of a pair of dies, a portion of the metal is forced up into a small bulb, thus, ; by a beautifully simple and automatic arrangement, it is passed into another, when a small horizontal hammer gives it a sharp tap, which completes the head. The white colour is produced by boiling in a solution of cream of tartar and tin. They are then dried, and passed into the hands of the wrappers-up. The preparation or marking of the paper is peculiar, and is done by means of a moulded piece of wood, the moulds corresponding to those portions which represent the small folds of paper through which the pins are passed, and thereby held. The pins are then taken to the paperers, who are each seated in front of a

bench, to which is attached a horizontally-hinged piece of iron, the edge of which is notched with a corresponding number of marks to the number of pins to be stuck; the small catch which holds together the two parts of the iron is released, the paper introduced, and a pin inserted at every mark: the paper is then released, and the task of examination follows, which is the work of a moment. The paper of pins is held so that the light strikes upon it; those defective are immediately detected by the shade, are taken out, and others substituted in their stead. An ancient edict of Henry VIII. held that "no one should sell any pins but such as were double-headed, or the heads soldered fast on."—W. C. A.]

337 WAKEFIELD, J. T., *Lichfield Street, Birmingham*—
Manufacturer.

Various specimens of wire, wire gauze, and wire goods.

338 MYERS & SON, *Newhall Street, Birmingham*—
Manufacturers.

Specimens of steel pens, and improved steel pen and quill penholders, in gold, silver, and other metals.

339 MITCHELL, JOHN, 48 *New Hall Street, Birmingham*—
Manufacturer and Patentee.

Patent self-adapting pens and holder, and steel-pens in numerous varieties.

340 MESSENGER & SONS, *Broad Street, Birmingham*
—Manufacturers.

Domestic groups of the Queen and the Prince of Wales, in or-molu and bronze.—Modelled by John Bell.

Equestrian statuette of the Duke of Wellington, in bronze.

Portion of a chandelier in bronze, as designed by Mr. Gruner, for the Pavilion in Buckingham Palace gardens.

Ornamental design in or-molu, as a balustrade for a staircase. Capital, in or-molu, taken from the temple of Jupiter Stater, at Rome.

Ornamental bracket, for gas, in or-molu. Candelabra, for gas, in or-molu and bronze. Ornamental scroll and support, in iron, bronzed.

Antique tripod and candelabrum, for gas, in iron; antique eagle candelabrum, for gas, in or-molu; tripod candelabrum, in iron, for gas, bronzed.

Candelabrum, in the style of Louis Quatorze, six-lights, for candles, in or-molu.

Gothic candlestick, in or-molu. Gothic vase, in bronze. Ornamental group, for a letter balance.

Antique Roman vases, in bronze.

Groups, consisting of bull, cow, and calf, forming an inkstand. Group of goats, forming an inkstand.

Cupid's compasses, a watch and thermometer stand, registered inkstand.—Groups of fighting horses. Cups, "Match in the dark." Rustic scene. Antique caskets. Scent vases. Ornamental match-holder, "Gipsy figures." Candlestick, Climbing-boy. Letter-balance, Justice. Inkstand, Antique stag. Registered ornamental match-holder. All in or-molu and bronze. Various specimens in bronze.

Registered station signal, and tail-lamps. Hand signal lamps, in brass, exhibiting three colours. Double and single gauge, and porters' ticket-lamps. Registered roof-lamp, for carriages. Lamp on the old principle. Side and double side signal lamp. All for railway purposes. Carriage lamps, plain silver mounted. Variety of patterns of general gas fittings, engine cocks, &c.

[Bronze varies in its composition according to the taste of the artist as to the depth of colour or its hardness; a very excellent bronze is formed by the addition of 2 oz. of tin to 16 oz. of copper.

The casting of a bronze statue may thus be described: the core is made up of brick-work and clay until a rude representation of the intended work is made; upon this the sculptor models, in wax, of the thickness intended for the metal, all the details, such as the features, drapery, &c.; when this is completed, it is coated with loam of very thin consistency, then follow repeated solid coatings of clay, &c., until a shell of sufficient strength to bear the pressure of the melted metal is formed; the whole is then bound together, heat is applied, the wax is melted out, and a space thereby left for the introduction of the metal; suitable runners are made, and vents to allow the free escape of air. The metal is melted in reverberating furnaces, and, when in a proper condition, the plug is withdrawn, and the mould filled. After being allowed to remain until cool, it is opened, the roughness cleansed off, and the statue is completed. The peculiar tinge of the bronze is acquired by exposure to the air.

A bronze of nearly the same tinge is given to brass by immersion in a mixture of spirits of salt and arsenic; the metal is to be heated previous to this; the article is thereafter brushed with black lead, and, after being again heated, is coated with a lacquer, composed of lac and spirits of wine, with a little yellow colouring matter; the shade of antiquity is thus imparted in a few minutes.

The establishment of the exhibitors is one of the oldest in the trade in Birmingham; it has been in existence upwards of 50 years; it was one of the earliest to recognise the importance of the union of art with manufactures. For this, the skill of Flaxman and Chantrey was called into requisition; artists, celebrated for their skill in architectural enrichment, were also employed in the modelling of balustrades, candelabrum, tripods, &c.—W. C. A.]

341 STURGES, RICHARD FORD, 46 *Broad Street, Birmingham*—Manufacturer and Patentee.

Electro-plated articles on hard white metal. Urns, lamps, candlesticks, stands, trays, frames, tea and coffee pots, pneumatic coffee filter, jugs, spoons, &c. These articles are made by a process, without seams or soldering, so as to diminish labour and cost; particularly that of embossing and chasing.

The articles are cast in metal moulds, in a heated state; a stream of water is made to play upon the moulds, when filled with hot metal, which causes the mould to contract, and thus produce a greater degree of sharpness in the fine parts of the casting; the metal used expands in cooling.

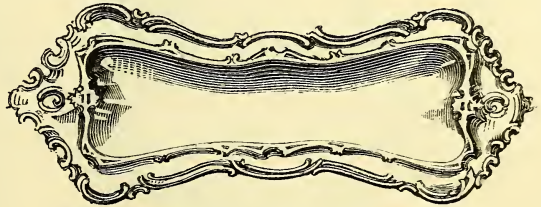

Sturges' Electro-plated Snuffer Tray.

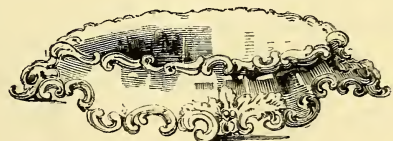

Sturges' Electro-plated Decanter Stand.

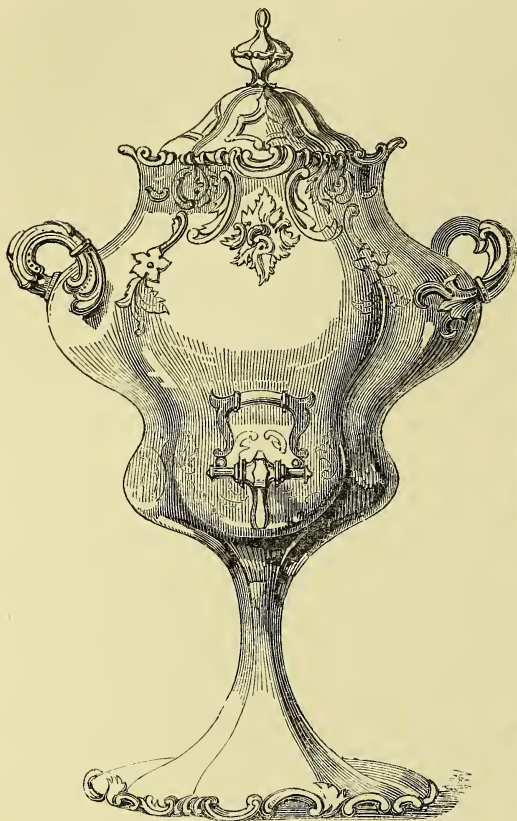

Sturges' Electro plated Tea Urn.

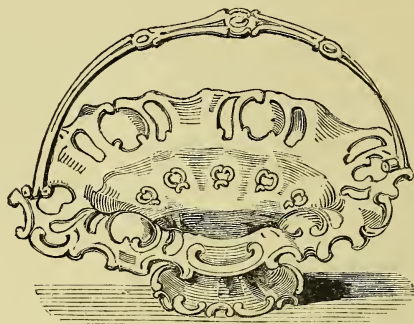

Sturges' Electro-plated Cake Basket.



Sturges' Electro-plated Candlestick.



Sturges' Electro Plated Tea Kettle and Stand.

342 PRIME, THOS., & SON, *North Wood Street, Birmingham*
—Designers and Manufacturers.

Specimens of magneto-plate salver. Liquor frame with grotesque handle, and various magneto-plated articles for household use.

Magneto-plate dessert knives and forks, with silver handles, and spoons of new and various patterns.

343 SALT & LLOYD, *17 Edmund Street, Birmingham* —
Designers and Manufacturers.

Stands for candle, oil, and camphine lamps. Improved camphine lamp. Candelabra. Gaseliers. Specimens of cast brass from Bankart's patent copper; and of English's patent camphine.

345 EDWARDS, E., *Birmingham*—Manufacturer.

Various glass inkstands, filled with black, blue, and red ink. Junction inkstand, containing black and red ink in one vessel. Safety inkstand, for use on ship-board. Tropical inkstand, with self-closing lid, to prevent evaporation and exclude insects.

Bronzed inkstands of cast iron. Cast-iron inkstands, "camel reposing," and early Gothic designs.

Glass screws, showing the method of manufacturing twelve at once by pressure.

[The following note, on the Birmingham productions, may be acceptable in this place.

A large number of the articles most commonly manufactured at Birmingham are not produced in extensive factories in which large capitals must be employed for

the erection of machinery. Almost all the small wares of the district are made by workmen, who undertake, each one in his particular line, to execute orders received by the merchants and agents settled in the town. The profitable performance of their contracts, however, calls for the employment of a cheaper kind of power than is at the command of men who, like these workmen, have little or no capital; and this course of business has opened a channel for the employment of money in the town, in a manner which is found to be profitable to those who engage in it, and advantageous to the small manufacturer. The plan alluded to is this: a building, containing a great number of rooms of various sizes, is furnished with a steam-engine, working shafts from which are placed in each apartment, or workshop, which is likewise furnished with a lathe, benches, and such other conveniences as are suited to the various branches of manufacture for which the rooms are likely to be needed. When a workman has received an order for the supply of such a quantity of goods as will occupy him a week, or a month, or any other given time, for their completion, he hires one or more of these rooms, of sizes and with conveniences suited to his particular wants, stipulating for the use of a certain amount of steam-power. He thus realizes all the advantage that would accompany the possession of a steam-engine; and as the buildings thus fitted up are numerous, competition on the part of their owners has brought down the charge for the accommodation they offer to the lowest figure that will ensure to them the ordinary rate of profit on the capital employed.

At the same time as this peculiarity exists in this great metal mart, it must be understood that there are some most extensive establishments from which many of the largest contributions to the Exhibition have been received, that contain within their own premises all the elements of production.

346 **LOWE, JOHN & HENRY, Clarence Works, Birmingham**
—Manufacturers.

Carriage-lamps, harness mountings, saddlers' ironmongery, &c. Adjusting-iron for dash-lamps, suitable for sweeps of carriage dash-boards. Collinge's patent axle. Clarence carriage-step. Carriage-roller, bolt, and tread. Drag-shoe. Plain and forked turned swells. Fulcrum for gig-shafts. Dog-cart screw, and side iron. Head-work, &c. Hunting, hackney, and ladies' bridles, breast-plates, and steel bits. Snaffles, pelhams, and stirrups. Gig and carriage bits, spurs, &c.

[The manufacture of saddlers' ironmongery is principally located at Birmingham, and in the neighbouring towns of Wolverhampton, Walsall, &c. Its object is the production of bits, spurs, stirrups, curb-chains, &c. These are formed out of iron and steel, by the ordinary process of hammering; and are finished by japanning, tinning, burnishing, or plating with brass or silver. Some produced for the South American market, are of very fantastic shapes, and richly gilt; they differ from those for home use in their massive appearance, the sides of the bits being carved into various designs, and the rowels of the spurs are made enormously large. When bits are to be plated with metal, they are tinned, and a piece of metal of sufficient thickness is wrapped or bent round it by pressure, this is aided by pressing down upon them with burnishers, &c. When the covering has been made to adhere very closely, the whole is heated, tin solder is applied, and the two become united; the final polish is given by the friction of buff leather and powdered burnt rotten-stone.—W. C. A.]

347 **WOOLDRIDGE, JOSIAH, 38 St. Paul's Square, Birmingham**—Manufacturer.

Or-molu door lock and bell lever, designed by T. C. Hine, architect, Nottingham; modelled by Joseph Jennings, James Street, Birmingham.

Brass bell levers, door handles, hat and coat hooks, parts glass and china.

Brass window stay, self-acting stay; door hinges, and book clasp and hinge, by Joseph Jennings.

Door latch, tassel hooks, and casement catch.

Brass flush and socket door bolts, window blind pulleys, sash fasteners and screws, table fasteners, bell slides and cranks.

Brass hooks, hinges, handles, rings, and castors of various patterns.

Brass deck light and ventilator, stove ventilators, hammock hooks, door stay, pin and nut, pin and chain, bolt, toy cannon.

[The or-molu of the brass-founder, popularly known as an imitation of red gold, is extensively used by the French workers in metals. It is generally found in combination with grate and stove work. It is composed of a greater proportion of copper and less zinc than ordinary brass, is cleaned readily by means of acid, and is burnished with facility. To give this material the rich appearance, it is not unfrequently brightened up after "dipping" (that is, cleaning in acid), by means of a scratch brush (a brush made of fine brass wire), the action of which helps to produce a very brilliant gold-like surface. It is protected from tarnish by the application of lacquer.—W. C. A.]

348 **HOLDEN, HOWARD ASHTON, 96 Suffolk Street, Birmingham**—Manufacturer.

Plain and chased door-handles, carriage-door hinges, mouldings and door-beading, staples, escutcheons, harness-buckles, mountings and ornaments, railway-handles, carriage-beading, hinges and furnishings.

Chariot lamps, railway buffer, and tail-end lamps. Hand signal-lamp, with registered improvements. Side signal lamps.

[Door-handles, whether for ordinary carriages or for railway purposes, hinges, buckles, &c., are first cast, and the ornamental parts finished by being chased. Some, of a more ornamental kind, are produced by a union of stamped and cast work, the former being attached by solder to a foundation of cast brass or iron. Beading is formed out of sheet metal, and is drawn through a steel hole in the same manner as a tube, but with a plug introduced, for the purpose of keeping it in shape; the sprigs by which it is attached are inserted at the time when the solder is applied to fill up the back. The solid moulding is formed by rollers, and is made out of solid ductile brass, the circumference of the rolls being grooved to a corresponding form to the shape of the moulding required.—W. C. A.]

349 **BLEWS, WILLIAM, & SONS, Bartholomew Street, Birmingham; and 55 Bartholomew Close, London**—Manufacturers.

Brass candle and ship lamps, the glass pillars manufactured by Messrs. Richardson, of Stourbridge.

Candlesticks—brass, and imperial metal.

Imperial standard peck and gallon measures, made from the original patterns as supplied by the late Mr. Bate for the Exchequer, London.

Weights—brass, solid, &c.; and circular sovereign weights from 100 sovereigns down to a half-sovereign.

Large bell, in frame, for steam-vessels; and small, in brass frame.

Scuttles—brass, and ship, fitted with Lockhead's patent perforated glasses.

[Bell and candlestick founding and making are understood, in the Birmingham trade, to go together. The operation of casting may be similar, but the composition of the two metals is exceedingly different, the one being hard, the other pliable and ductile. Bell-metal, though composed of two of the softest of metals, viz., copper and tin, when united in the proportion of four to one, forms a mixture easily broken and capable of producing sound. Small bells are cast in sand, those of a large size are produced in loam.

Candlesticks are cast in sand, and made hollow by the introduction into the mould of what is called "a core," viz., a piece of sand corresponding in size to the hollow of the pillar. Upon his skill in making this, in such a manner as to produce uniform thickness of metal throughout, depends the success of the workman; the metal must also be of a proper temperature, or the casting is rendered useless by the presence of flaws. Candlesticks are finished by being turned, and polished by friction when in a state of motion in the lathe; the bottoms, when round, are also turned; when square, they are filed and polished. The composition of the metal, in this case, is copper and zinc, in the proportion of 16 ounces of the former to 8 ounces of the latter.

Lockhead's patent glass is produced by a roller having, on its circumference, projections corresponding to the apertures intended, which is made to traverse the surface of the glass; when in a molten state, an indentation is made for every projection, and the whole is finished by grinding, which removes the extra glass and relieves the apertures. It is useful for purposes of ventilation.—W. C. A.]

350 DUGARD, WILLIAM & HENRY, *Upper Priory, Birmingham*—Inventors and Manufacturers.

Carriage-lamps, full, plain, and fancy, silver and gilt-mounted. Silver and gilt-mounted winker.

Registered collar, full silver-mounted: it requires no hames, and can be put on over the neck instead of the head. Collar with patent leather silver ornaments, and coat of arms.

New pattern hames, plated on German silver, and cased on iron.

Improved pattern of hair horse-saddles, silver-mounted: and with fronts and rosettes. Silver-mounted saddle-top.

Improved shaft-tugs, open and closed.

Registered, brass-mounted, thiller cart-horse collar, "miniature."

351 HETHERINGTON, T., & Co., *28 Cannon Street, Birmingham*—Manufacturers.

Circular chariot lamp, full silver mounted, with engraved glasses, and chased edges.

Chariot five-glass lamp, viz., two oval and three bent glasses, gilt, full silver mounted.

The Albert chariot lamp, full silver mounted, with chased edges, and three stained and engraved glasses.

The royal crown chariot lamp, full silver mounted and chased, with engraved glasses.

The Prince of Wales lamp, full silver mounted, with chased edges, and engraved glasses.

The chariot lamp of Industry, full silver mounted.

The chariot three-glass lamp, full silver mounted, with engraved front glass, side glasses stained, gilt and enamelled.

352 EVERITT, A., & SON, *Birmingham*—Manufacturers.

Brass tubes, for locomotive and marine boilers; copper and brass tubes, for gas, steam, &c.

Specimens, showing the process of manufacture of rolled metals, and of brass and copper wire.

[Rolled metal (brass) is produced by melting the metal to be rolled in clay crucibles; when sufficiently melted, mixed, and fluxed, it is poured into iron ingots, &c., which have been previously smeared with oil. After this, the "strip" is passed into the hands of the roller, who proceeds to what is technically called "break it down;" then follows the process of reduction. The huge iron rollers used in the operation are fitted with screws or appliances for bringing their surfaces in closer contact. The metal is annealed in muffles, scaled, and pickled (cleaned and washed in an acid solution), and in certain cases where brightness is necessary, it is finished by being passed through bright-rolls.—W. C. A.]

353 BOLTON, THOMAS, *Broad Street Metal Works, Birmingham*—Manufacturer.

Sheet brass, German silver and copper. Specimens of the process of manufacture of brass wire, round and shaped brass and copper wires, and of tubing. Brass and copper tubing; locomotive and mandril drawn tubing. Brass solder.

[The metal of which brass wire is formed is cast in strips and rolled to the required thickness; it is then "slit" into square rods of metal by the operation of cylindrical rollers; the larger sizes of wire have corners taken off by being passed through a pair of rolls; the smaller sizes are at once passed through steel draw-plates.

Brass or other tubes are formed from rolled metal, which is cut to the required breadth by means of revolving discs; in the large sizes of tubes, the metal is partially curved in its length by means of a pair of rolls; when in this condition, it is passed through a steel hole or a die, a plug being held in such a position as allows the metal to pass between it and the interior of the hole. Oil is used to lubricate the metal; the motion is communicated by power, the drawing apparatus being a pair of huge nippers, which holds the brass, and is attached to a chain which revolves around a winlass or cylinder. The tube, in its unsoldered state, is annealed, bound around at intervals of a few inches with iron wire, and solder and borax applied along the seam. The operation of soldering is completed by passing the tube through an air stove heated with "cokes" or "breezes," which melts the solder and unites the two edges of the metal, and forms a perfect tube; it is then immersed in a solution of sulphuric acid to remove the scaly deposit on its surface, the wire and extra solder having been previously removed; it is then drawn through a "finishing hole plate," when the tube is completed.

Mandril drawn tubes, as the name indicates, are drawn upon a very accurately turned steel mandril; by this means, the internal diameter is rendered smooth; the tube formed by this process is well fitted for telescopes, syringes, small pump-cylinders, &c.

Brass solder is composed of almost equal quantities of copper and zinc; its properties should be that of melting at such a temperature as will allow the article to be soldered to be sufficiently heated, but yet some degrees from melting point. Solder is always used in connection with borax, the cleansing properties of which appears to facilitate the fusion of the metal.—W. C. A.]

354 SOUTTER, WILLIAM, *10 Market Street, Birmingham*—Manufacturer.

Copper-bronzed tea urns, and swing kettles. Bright copper-fluted coal vase, and round or oval kettles.

355 HILL, JOSEPH, *Broad Street, Birmingham*—
Manufacturer.

Specimens of stamped ornaments, used in the manufacture of lamps, chandeliers, &c., made from sheet or rolled metal.

The metal in its raw state, copper and spelter; mixed and prepared for rolling; rolled.

Rough shells finished from the stamp; and from the soldering.

Shells cleaned from the scale, by means of aquafortis, ready for burnishing.

Six-light body and arms, cleaned, burnished, and lacquered.

Lamps in the finished state.

[In these specimens, the oxidated or scaly appearance of the metal, when undergoing the process of manufacture, will readily be detected; the parts at which the soldering has been also made, are shown by the brightness of the seam. The glassy appearance at this part, when uncleaned, arises from the use of the borax, which is employed to protect that portion of the brass to be soldered, from becoming dirty; it also acts as a flux, facilitating the running of the solder. Immersion in weak nitric acid effectually removes the scales, after which various strengths of the same acid are used until the articles are entirely cleansed; they are finally dried out in box saw-dust, and burnished.—W. C. A.]

356 WHITFIELD, SAMUEL, *Oxford Street, Birmingham*—
Manufacturer.

Varieties of window cornices in stamped brass-foundry, with crimson and blue velvet, wainscot and knotted oak, rosewood, and white enamel ground introduced.

Impregnable wrought-iron fire-proof safe, of thick plates dovetailed and riveted together.

Wrought-iron fire-proof book-case. Wrought-iron fire-proof deed-box.

Wrought-iron treasure chest for exportation, which can be taken to pieces for the convenience of land carriage.

Wrought-iron fire-proof cabinet, japanned, and suited to the library, the dining-room, or the office. Fitted with Cotterill's patent climax detector locks.

The above are all lined and filled with a non-conducting substance, which effectually prevents the contents of the box or chest being injured by the heat, even should the outer metal be exposed to a very high temperature.

357 LLOYD, GEORGE B., *Berkeley Street Tube Works,*
Birmingham—Manufacturer.

Specimens of lap-welded iron tubes, as used in marine, locomotive, and other steam boilers; the same tubes with fittings for conveying gas and water; and for hydraulic presses. These tubes are produced by improved machinery which ensures regularity and accuracy of finish, and they can be made in any lengths not exceeding 15 feet.

358 THOMAS, R., *Icknield Works, Birmingham*—
Manufacturer.

Brazil axes. American wedge axes, and hand hatchet. Shingling hatchets, assorted patterns. Cooper's adze and axe. Round and square eye adze. Mahogany squaring axe. English carpenter's axe.

Eyed shell and screw auger. Double plane iron. Socket chisel. Trowel. Gun and hand harpoons.

Improved grass shears; and a variety of garden tools, to screw into one handle.

[The articles here exhibited illustrate the heavy steel "toy" trade of Birmingham. The manufacture of the axe used by the backwoodsman, of the hoe used in the agriculture of the tropics, the pick used by the Caffirs of the Cape, and the harpoon of the whale-fisher, gives em-

ployment to many artizans in its vicinity. In order to convey a general idea of the process by which these articles are "got up," the manufacture of an ordinary axe may be selected. A piece of iron is taken, and after being heated, is doubled over a piece of steel corresponding in form to the future eye which is to hold the shank; it is not then welded together. A small piece of steel which is intended to form the future cutting edge, is heated along with the iron back to a welding heat, and is passed under a tilt-hammer (that is, a large hammer driven by steam or water), which speedily flattens it out; it is then exposed to another heat, and the eye is completed with the small hammer. The superfluous iron or steel is removed at the edge by a pair of large scissors. The process of hardening and tempering follow; the grinding is performed on stones, which cuts away the iron and discloses the steel edge. The "glazing" on emery "bobs" or wheels succeeds, and the polishing is effected by means of oil and emery on a similar tool. Considerable improvement in appearance is imparted by the use of a blue varnish which is applied to the axe, and drying in a small stove. "Toy" is a technical term applied to an anvil, a hammer, and various incongruous objects which are comprised under the "heavy steel trade," readily understood by the initiated.—W. C. A.]

359 TAYLOR, WILLIAM, *13 Sheepcote Street, Birmingham*
—Inventor and Manufacturer.

Original designs for nut-crackers, sugar-tongs, door knockers, and improved inside shutter bars.

360 WORDSWORTH, JOHN, *Birmingham*—Designer and
Manufacturer.

Model of an economical kitchen range, intended for a close or open fire, and for curing a smoky chimney. By closing the oven dampers and opening the folding doors at the back of the range, it assumes the appearance of a common oven grate with open fire.

360A KENRICK, ARCHIBALD, & SONS, *West Bromwich,*
Staffordshire—Manufacturers.

Model of an enamelled tank or cistern, composed of cast-iron plates, screwed together with gutta percha joint.

Model of enamelled water or gas-pipes, and water-closet pan, with trap-pipe; dog trough, poultry trough, and spittoon.

Cast-iron enamelled culinary vessels. Registered spittoon.

Casting of saucepan broken to show the thickness; turned casting previous to being tinned or enamelled.

Cast-iron butts and patent pivot butts with sections showing the construction.

Frame pulleys; axle pulleys; castors; upright castors, side and screw pulleys.

Casting, showing the mode of arranging nails in the mould or flask, by which a great number are produced at one operation.

Specimen of enamelled plate and writing.

[The application of enamel for the protection of water-cisterns, pipes, &c., from oxidation, and for the lining of cooking utensils, is of comparatively recent date. The various materials of which the coating is composed (silic being the principal) are reduced to a fluid state: the article to be coated is dipped in the mass; a portion of the fluid adheres; it is then subjected to the heat of a muffle, and the whole becomes vitrified or reduced into a glassy covering, affording an excellent defence against oxidation, and a substitute for the protection afforded by tinning.—W. C. A.]

361 **TONKS, W., & SON, Cheapside, Birmingham—**
Manufacturers.

Brass foundry, &c., consisting of butt, stop, and other variety of hinges.

Ventilators, bolts, bell-cranks, pulleys, castors, chair-arms, picture, French pulley, espagnolette and stair rods, desk rails, and window fittings. Exhibited for quality of workmanship and cheapness of production.

362 **KIMBERLEY, JAMES, 56 & 57 Inge Street, Birmingham—**
Factor and Designer.

Manufactured articles, in stamped brass foundry, of a useful and ornamental character. These consist of curtain bands, cornice pole ends, window cornices, cornice pole brackets, letter clips, miniature frames, letter racks, medallions, brooches, door furniture, finger door plates, bell pulls, &c. In these articles portraits and emblematic designs, illustrative of Shakspeare and his works, are introduced.

363 **MARRIAN, JAMES PRATT, Slaney Street, Birmingham—**
Manufacturer.

Specimens of brass scroll ornament; the centre finished in "artistic bronze;" the outer compartments in Florentine bronze.

Specimens of naval brass foundry, consisting of ship-scuttles, &c. The grooves for the doors are fitted in some cases with cork, and in others with vulcanized India-rubber, to prevent the ingress of water.

Glass deck lights, mounted in brass, with brass ventilators.

Gun-hole screw valves. Brass hinges. Ordnance metal pulleys, with anti-friction rollers. Bracket candle lamp.

Registered oil and hand lamps, for bracket or table.

364 **BRISBAND, H., Howard Street, Birmingham—**
Manufacturer.

Specimens of mother-of-pearl and black pearl studs and buttons, of every description, from the smallest to the largest size known, either for use or ornament. Ladies' mother-of-pearl dress buttons, slides, and ornaments for dresses, &c.

[Pearl-button making is thus practised: The blanks are cut out of the shell by means of a small revolving steel tube, the edge of which is toothed as a saw; after which they are *flatted*, or reduced in thickness, by splitting, which is aided by the laminar structure of the shell. At this stage, being held in a spring chuck, they are finished on both sides by means of a small tool; the drilling is effected by the revolution of a sharp steel instrument, which acts with great rapidity. Ornamental cuttings are produced by means of small revolving cutters, and the final brilliant polish is given by the friction of rotten-stone and soft-soap, upon a revolving bench.—W. C. A.]

365 **ATKIN & SON, 115, 116, & 117 Barford Street, Birmingham—**
Manufacturers.

Specimens of circular saws, uniform in thickness, temper, and teeth.

Case of carpenters' and joiners' tools, containing specimens of hand-saws, back-saws, planes, squares, bevils, spokeshaves, gauges, saw-pads, turnerscrews, brad-awls, spirit-levels, saw-sets, braces, bits, augers, gimlets, and edge-tools. Specimens of skates.

[Saws are formed from plates of sheet steel, and are toothed not by hand but by means of a press and tools. Circular saws have the advantage of being divided in their teeth very accurately by means of a division plate; this prevents irregularity of size, and imparts smoothness and uniformity of action. The larger sizes of circular saws are made in segments, and connected together by means

of dovetails. All saws are hardened and tempered in oil; their irregularities are removed by hammering on blocks, and they are equalized by grinding. The several forms of teeth do not, as the casual observer may imagine, depend upon taste, but are those best fitted for cutting through the particular section, quality, or hardness of the material to be cut. The "set" of the saw consists in inclining the teeth at the particular angle known to be the best to facilitate the exit of the saw-dust, and thereby allow the saw to operate more freely. Iron bars, shaftings, &c., are cut to length by a steel circular saw, in its soft state, the iron to be cut being presented to the saw red hot; the saw rotates at a prodigious rate, and is kept in cutting condition, or cool, by its lower edge being immersed in water. A bar, two inches in diameter, is cut through in a few seconds.—W. C. A.]

366 **WRIGHT, PETER, Constitution Hill, Dudley—**
Manufacturer and Patentee.

Vice, with patent solid box, the worm of which is cut out of solid iron and case-hardened, thereby rendering it as durable as steel. Smiths' anvil.

367 **ASTON, JOHN, 20 Dale End, Birmingham—**
Manufacturer.

Brushes principally for the stable department, including horse, water, hoof, spoke, dandy, shoe, cloth, hair, carriage, plate, dish, boot-top, harness, bit, dog, hat, &c. Some of the above tastefully worked in various devices with dyed bristles. Horse toppings and throat ornaments. A set of military brushes complete, with horse, shoe, cloth, hair, and button brushes.

367A **ALCOCK, SAMUEL, Redditch, near Worcester—**
Manufacturer.

Artificial baits and flies. Superfine Kirby-bent and other hooks for angling. Silk and hair fly-lines and spring snaps. Plait silk and silk-twist lines. Plait hemp and cord lines. Fancy porcupine, cork, and quill floats.

Gimp, swivels, and artificial minnows. Furniture lines, and a variety of other tackle.

New ring fish hook, invented by the exhibitor, which enables an angler to fasten a fresh hook with the greatest ease, being perfectly safe, no tying whatever being required.

368 **WARDEN, J., jun., Old Church Works, Birmingham—**
Manufacturer.

Springs, axles, &c.—Waggon spring; grasshoppers spring. Cart arm; the same with patent linchpin. Scotch axle. Axles, mail patent, long and short bolts. Collinge's patent axle.

Patent waggon arm, with brass oil cap. Patent Scotch axles, with brass oil caps. Engineers' vice. Patent vice, with spherical washers. Vice, with solid brass box. Smiths' anvil. Specimens of faggoted iron.

370 **MAPPLEBECK & LOWE, Birmingham—**Proprietors.

Cast-iron chimney-piece, brown oxide (new mode of bronzing), with Berlin black ornaments.

Registered new pattern grate, with reverberating fire and ash-pan, fender and fire-irons.

Berlin black chimney-piece, with figure brackets. Black grate, with bright front and moulding, fender and fire-irons. Black register grate, with fender.

Bright grate, burnished steel and or-molu ornaments, with pierced burnished steel fender.

Bright grate, with or-molu ornaments, new ash-pan and fender, all of new patterns.

Fine polished fire-irons, of various patterns and new designs. Light fancy poker, and coal-vase tongs.

Brown's improved patent economical cooking apparatus, with automaton roasting jack, steaming apparatus, coffee roaster, &c. Automaton jack, without frame.

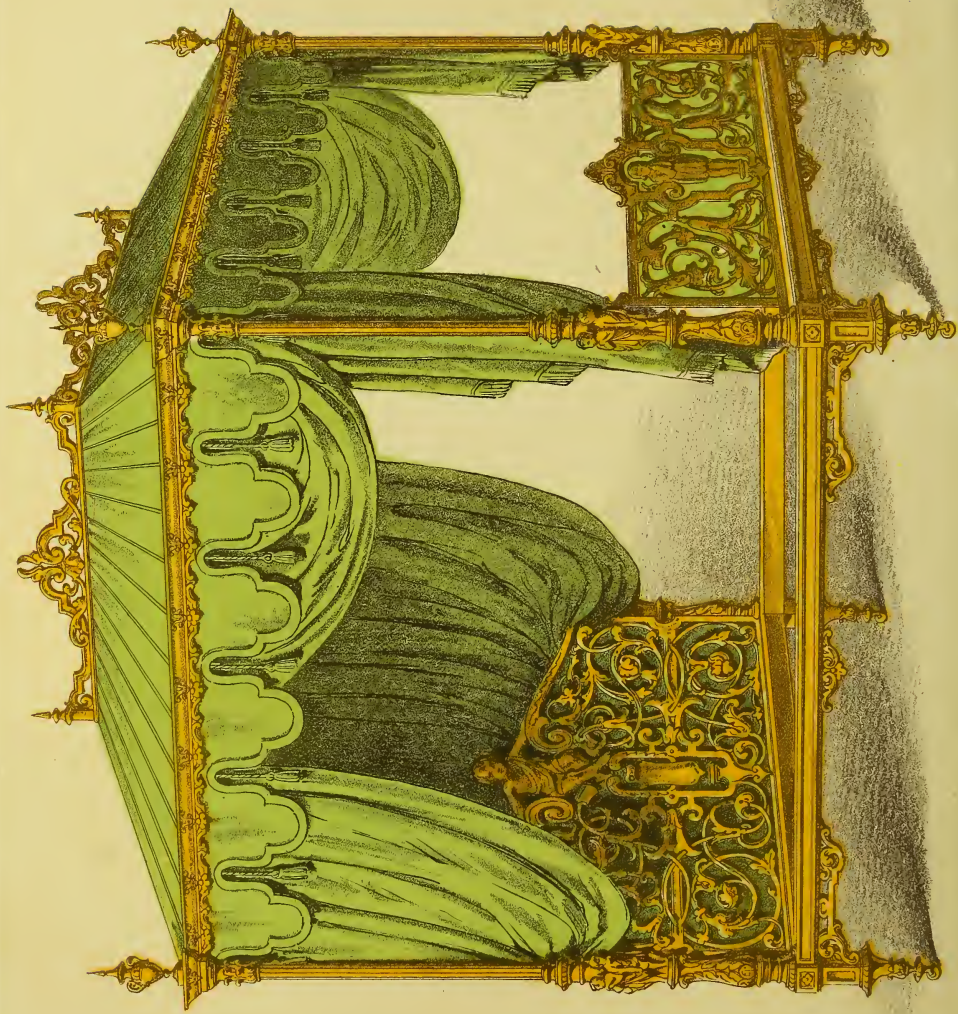

R. WAINFIELD, CAMBRIDGE STREET WORKS, BIRMINGHAM.

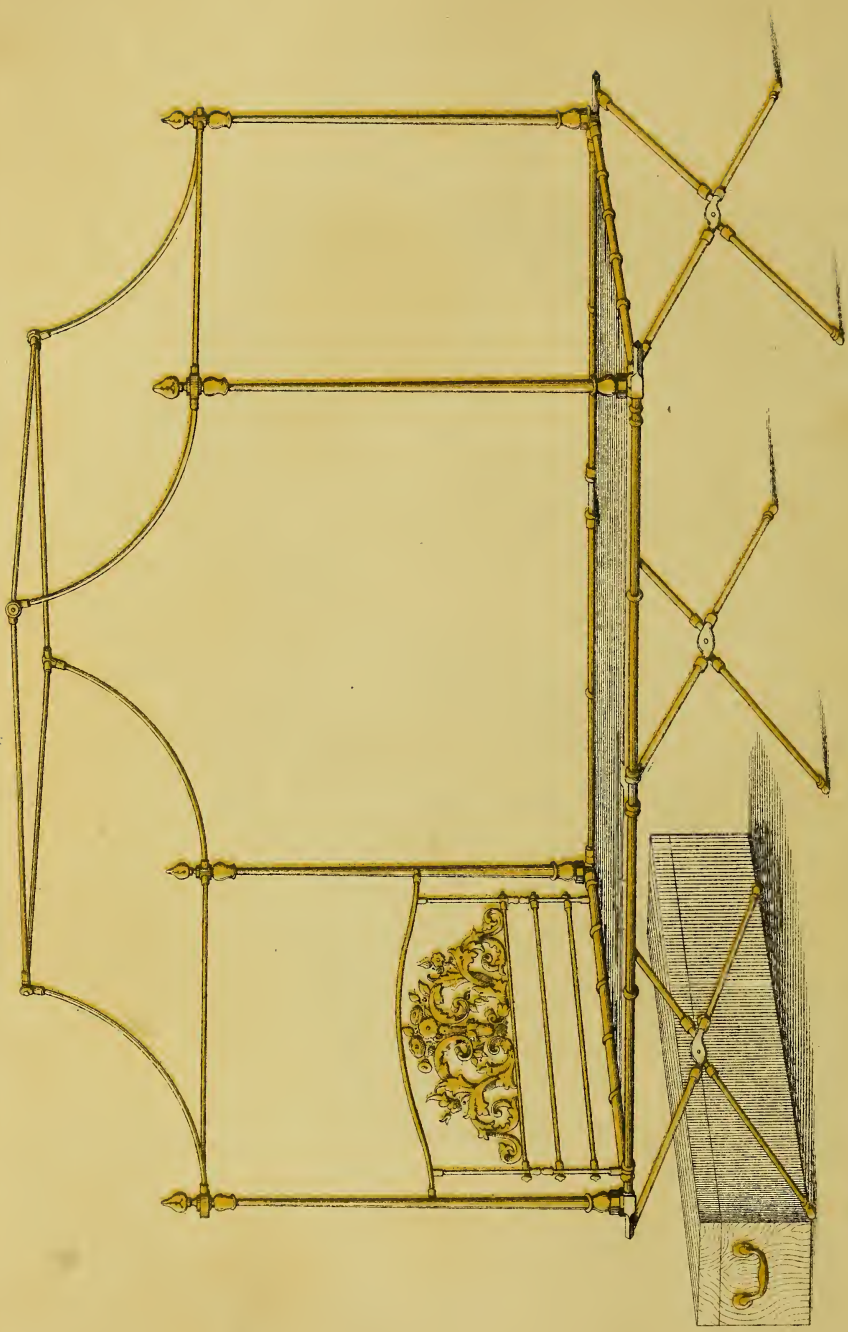

DAY & SON LONDON TO THE SHEEN

R. W. WINFIELD, CAMBRIDGE STREET WORKS, BIRMINGHAM.

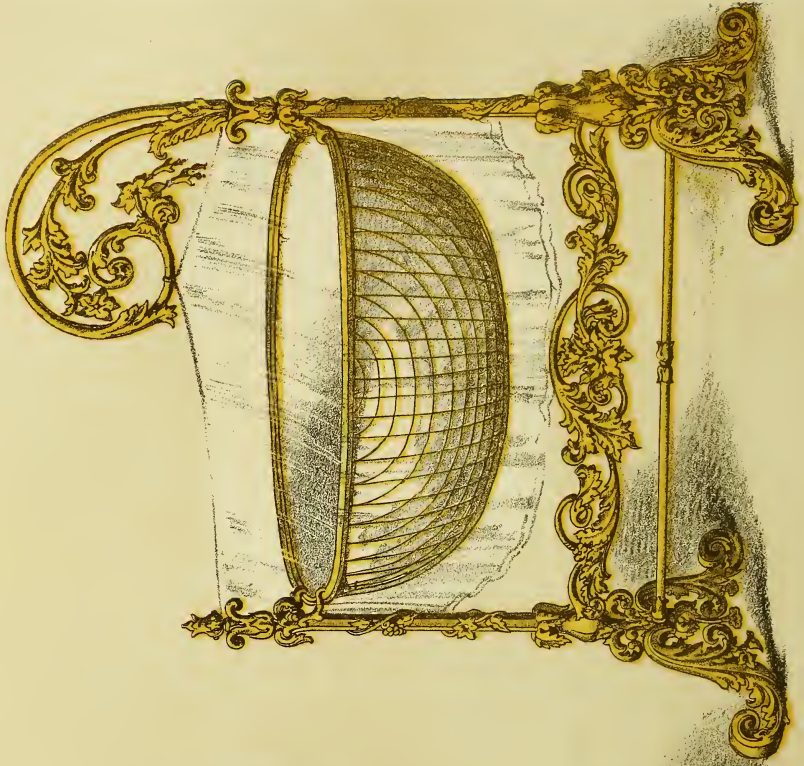



DAY & SON, LITHO^S TO THE QUEEN

R. W. WINFIELD, CAMBRIDGE STREET WORKS, BIRMINGHAM.



Day & Son Lith^{rs} to Fine Green

R. W. WINFIELD, CAMBRIDGE STREET WORKS BIRMINGHAM.

Superior open fire cooking range, with large oven and hot closet, strong wrought back boiler, wrought-iron roasting fire, and double fall bars, winding cheek, elliptic draught-plates with bright mouldings, latches, bands, and spit-racks, &c.

Improved smoke-jack, with two vertical motions, and one horizontal.

Open-top brass box end beam, for weighing bullion and other articles of value.

Small pillar scales for dispensing medicine.

Chemists' counter scales, brass box end beam, with sight hole cheek, open-top demi-turret brass pillar, with glass pedestal, and brass scales. Inverted weighing machine.

Brass standard scales, brass boxes, and end beams, solid brass weight scales, double brass cranks, and porcelain scales for provision dealers. Solid brass weights.

Engineers' stocks and dies, fitted with regular and master taps, and tapwrenches; also, with moveable plates.

Stocks and dies for iron gas tubing, fitted with dies and taps; also, with fluted taps, for whitesmiths' ordinary work.

Registered French bedstead, with cast-iron ornamental head and foot rail, &c.

Berlin black hall chairs. Bronzed brackets. Berlin black iron frame with glass and sconce. Flower-pot stand.

Tobacco and cigar stand, and inkstands, some with thermometer and watch opening; all Berlin black.

Self-acting spring tobacco box. Brown's improved valve for hot and cold water. Cinder sifter.

Model of Brown's improved patent universal cooking apparatus.

Model of a steam-engine furnace, with Bedington's patent smoke consumer. This smoke consumer can be applied to enclosed fire-places generally, in a short space of time, and at little expense.

371 PEYTON & HARLOW, *Birmingham*—Inventors and Manufacturers.

Patent improved metallic bedsteads, viz., brass four-post; and pillars of taper iron-tubing cased with brass ornamented pillars, with head and foot-rail. Iron four-post, with massive pillars of taper iron-tubing, head and foot rail, japanned to correspond with suite of papier-maché furniture exhibited by Messrs. Jennens and Bettridge. This bedstead is represented in the annexed cut.



Peyton & Harlow's Patent Metallic Bedstead.

Iron French bedstead, with canopy and taper tube pillars, ornamentally japanned, with brass mountings. Solid iron French, japanned. Series of pillars for bedsteads.

[In the articles here exhibited is introduced a method of casting together many of the parts, such as the head and foot rails, the block or dove-tails on to the corner of the posts, and the corresponding portion which fits on to the angle-iron, and forms the sides, head, and foot of the bed. This method of casting together consists in laying the various pieces of iron rod from which the rails are to be formed, into cast-iron moulds, ornamental intaglio impressions or cavities being left immediately under; when the mould is closed, a connection is made with these externally by means of an aperture; the melted metal is poured in, and a junction is effected. The production of taper tube pillars is effected by passing the "turned up" and soldered tube through a pair of rolls, whose external diameters are traversed by a groove proportioned to the taper to be produced; the tube internally is supported by a mandril.—W. C. A.]

372 POWELL, JOHN, *New Windsor*—Inventor and Manufacturer.

Windsor portable economical oven, for baking over the top of the fire, and leaving the front for other purposes.

373 WINFIELD, R. W., *Cambridge St. Works, Birmingham,* and *141 Fleet Street*—Patentee & Manufacturer.

Plain and ornamental cased and patent tubes, parallel and taper, the latter drawn by a patent process.

[These taper tubes differ from all others in the manner in which they are produced, viz. by being drawn at an ordinary draw bench, this peculiarity arising from the use of a ductile metal tool through which the soldered case, placed upon the mandril (whether reeded, fluted, octagon, &c.), is drawn. Twisted or spiral tubes can be produced by the same method. This method was first adopted by Mr. John Ward, one of the workmen in connection with the works.—W. C. A.]

Wire and rolled metals. Stair and carpet rods, beading-clips, and astragals. Bath-metal solder of various sizes. Tubes of various metals, for locomotive and other purposes. Picture hooks, rods, and brackets. Plain and reeded cornice-poles.

[The patent application of glass in the form of blossoms, leaves, and fruit to stamped brass-foundry, and more particularly to upholstery decorations, was suggested by Mr. W. C. Aitken.]

Patent glass and other stamped brass curtain-bands and pole-ends. Cornice-pole and curtain rings. Stamped brass window-cornices. Registered glass and other letter-balances. Drawn and filled brass bars and mouldings for sashes and shop-fronts. Brass name, door, and stall-board plates. Various specimens of patent and registered metallic bedsteads, and cribs, or children's cots.

Two ornamental cots for children in brass. In the one, the figure of a guardian angel at the head supports the curtain. In the other, the style of which is less elaborate and more simple, the curtain hangs from a scroll. These are both shown in the accompanying coloured lithograph.

[Among other improvements, introduced into the manufacture of metallic bedsteads, is the continuous pillar. Formerly it was made in two pieces, and jointed at the corner, and however firm this might be made at first, by wear it became loose. The improvement was invented and introduced by this exhibitor.—W. C. A.]

Brass rocking or lounging chair, with morocco furniture. Brass arm-chair, made portable, with morocco furniture. Brass tables with marble tops. Brass music stool. Patent and registered gas-burners.

[The applications of a perforated metal cap, the construction of argand burners out of stamped metal, and the use of enamelled glass as a reflector, in the form of a fluted cone, are due to Mr. John Hunt.—W. C. A.]

Bronzed gas chandelier with parian figures.

Artistic bronzed bracket, for gas, with parian figure and flowers.

Gas chandelier of the style of Francis I., with parian figures (suspended from an ornamental bracket).

Bronzed gas chandelier in the Elizabethan style, with ornamental enamelled shades. These chandeliers are represented respectively in the coloured lithographs which accompany this page.

Gas chandelier with birds and figures. These articles are registered. Ornamental hall lamp with etched glass (after the antique).

[Brass castings are produced in sand by means of patterns. The making of these patterns, or models, is a work involving no small amount of skill and knowledge; the simpler kinds are made by the ordinary workmen; but in cases where figures, foliage, or animals are introduced, the eye and the hand of the artist become necessary. The object is first designed, then modelled in wax; a cast in lead is formed, it is then cast in brass and chased; this forms the pattern, or model, for the caster.

Ordinary globular or simple forms are readily copied; but when the human figure, animals, or foliage is introduced, the difficulty is increased. The castings can only be effected by means of false coreing, viz., hanging pieces of sand, which are made up and lifted out in solid portions before the model can be removed, and which thereafter are again introduced. An ordinary plaster cast, with the seams upon it, if examined, will best explain the meaning of every square or compartment marked thereon, and shows when a core has been in a metal casting. To put the sand in a condition to produce a finer impression, powdered charcoal is dusted upon it, the cores being introduced, the moulds closed having been previously dried, and runners made for the introduction of the metal (which is usually melted in earthen or clay crucibles, and in an air furnace, the fuel used being coke), follow, and complete the operation.—W. C. A.]

Table-stands for gas, suited for flexible tubes with figures, emblematic of the arts, science, and industry.

Moveable gas-stands, with parian figures and flowers.

Bronze candelabrum; the base contains medallions emblematic of poetry, philosophy, and music, and is surmounted by figures of Art, Science, and Industry.

A four-post brass bedstead clothed in green silk, the metal work in the renaissance style, with figures, foliage, and scroll-work introduced.

374 GORTON, GEORGE, *Birmingham*—Inventor and Manufacturer.

Drawing-room grate, with plate-glass front and or-molu ornaments. Steel-fender, with or-molu ornaments. Dining-room grate. Ornamental cast-iron fender, steel mouldings and support; with fire irons. Registered designs.

378 KEED, G. J., *100 Crawford Street, Marylebone*—Inventor.

Improved kitchen cooking apparatus with steam-kettles and closet.

379 ANDREWES, H. P., *2 North Street Mews, Tottenham Court Road*—Inventor, Manufacturer, & Proprietor.

An emigrant's stove and general cooking apparatus. Meat screen and reflector; the reflector may also be used for browning pastry and other articles.

380 GODDARD, HENRY, *Nottingham*—Manufacturer.

Patent domestic cooking apparatus. Its object is a great amount and variety of uses at one time with a small fire; the hot-plate is formed by the entire top of the apparatus

381 WAKEFIELD, FRANCIS, *Sherwood Iron-Works, Mansfield*—Designer and Manufacturer.

The Great Western cooking apparatus.

Sherwood range; having a common oven, an upper one for baking pastry, &c., and a steam closet, for preparing meat, vegetables, &c. This range is shown in the cut, which is a front elevation of it, and represents the various ovens, closets, &c., attached to it.

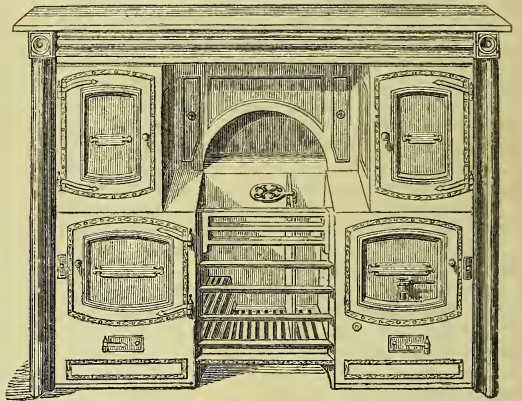

Wakefield's Sherwood Range.

Artizan's self-acting cooking stove; designed for the dwellings of the working-classes.

Bright register stove grate, with steel and or-molu mountings. It contains a new method of distributing heat equally throughout the room.

Specimen of wrought-iron palisading and coping.

Iron casting of antique bronze statuette of Bacchus.

382 LOVE, JAMES, *20 St. Andrew's Square, Glasgow*—Inventor.

Gas apparatus for heating, cooking, and lighting hotels and taverns, which generates gas without interference with the cooking or heating; adapted for the colonies, or cold countries.

Machine, or boiler, for generating steam and gas in the same apparatus; it is of a circular shape, and has only a small furnace; adapted for country works that require gas-light and steam.

New room-grate, constructed to save fuel, obviate smoke, and prevent the loss of heat. It imparts a large proportion of its heat to the air in passing into the room, and the flues are constructed to prevent taking fire.

Machine for generating gas, and illuminating locomotive engines and carriages.

Gas machine, adapted for lighthouses of every description, which requires no oil or grease, and from its simple construction, can be fitted into any place where cooking is required.

383 PETERSON, T., *Water Lane*—Inventor.

An economical stove.

384 YATES, HAYWOOD, & Co., *Effingham Works, Rotherham, Yorkshire, and 200 Upper Thames Street*—Manufacturers.

Specimen of drawing-room iron register stove grate and fender to match, in or-molu and burnished steel, combining the appliances of science to a modern English grate, and uniting some novelties with the palatial character of the middle ages; with mantelpiece executed by Mr. Hartley, Westminster Marble Works, London.

Pier table and flower-pot stand, in cast-iron gilt.

Dining-room register stove grate, in polished black, with burnished steel mountings, complete with hearth, and fender; with mantelpiece in Berlin black.

Parlour, breakfast-room, and bed-room register stove grates, with fenders. Cottage sham or full stove grate with iron mantel. Cottage elliptical stove grate.

Miniature model of a drawing-room grate and mantel, on Jeffrey's patent pneumatic principle.

Warm air and other stoves, for public buildings, &c.
Self-acting cooking stoves, with modern improvements.
Hall tables. Flower stands. Umbrella stands, and other ornamental castings.

386 SLATE, JOHN, 14 Belmont Place, Wandsworth Road—
Inventor and Patentee.

Patent stove, for the cure of smoky chimneys. "The security against the smoke returning into the room is the passage placed a little above the top part of the front of the stove, and the chimney-plate is placed in a rising position from the front to the back, and whether the flue be to the right or the left, the chimney vane, or smoke director, may be adjusted accordingly, or left in the centre, so as to admit of a descending and ascending current."

Improved smoke spreader, intended to slip on a cement or other pot. The same, with additional pipe made to set in brickwork.

Pneumatic pot with two worms, internally arranged with side draughts.

387 EDWARDS, FREDERICK, 42 Poland Street—
Manufacturer.

Dr. Arnott's circular and oblong bronzed corrugated stoves for warming churches, chapels, large halls and staircases, public buildings, &c.; by the corrugation of the body of the stove, the heating surface becomes multiplied nearly three times, and by means of the self-regulating valve the admission of air to the fire is so regulated, that it only needs replenishing with fuel once in 12 or 18 hours. This stove is shown by a front elevation and plan in the cut. The amount of heating surface is partly represented by the indented line in the plan.

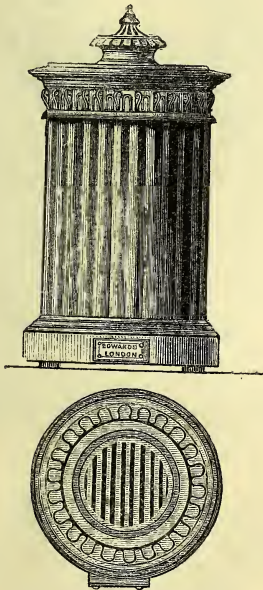

Edwards's Arnott's Stove.

[This stove which needs to be lighted only once in the season, and to be supplied with fuel only once, or twice if desired, in twenty-four hours, consumes its fuel as uniformly as an hour-glass lets fall its sand, and can be adjusted to burn permanently at any wished-for rate. With much saving of fuel and very much saving of trouble, it insures in any place a steadiness of temperature, which no watching and service can obtain from common fires. It also facilitates perfect ventilation. The stove of corrugated form has much surface and corresponding heating power with small bulk.

The uniform action of the stove is maintained either by the thermometer valve, described at length in Dr. Arnott's

"Treatise on Warming and Ventilating," or by his balanced valve, seen on the stove now exhibited. The principle of the first is, that the thermometer used is of a kind which not only indicates the heat, but narrows the passage for the air that feeds the fire, whenever the heat rises at all above the desired degree; or widens the passage when the heat falls below it. The principle of the second or balanced valve is, that the air-current entering towards the fire tends to close the valve, while a weight on the balanced frame which carries the valve doors, tends to open it, and the valve becomes stationary, when just enough air enters to support the weight. The amount of weight, therefore, used at any time determines the rate of combustion.]

Dr. Arnott's chimney valves, for ventilating apartments generally; various forms of these ventilating valves are shown in the annexed cut.

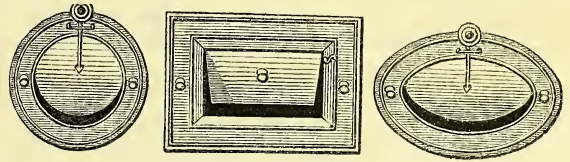

Dr. Arnott's Chimney Valves.

[This valve allows free passage for air from an opening in the wall near the ceiling of a room into the chimney flue, but no passage in the contrary direction. With the proper contraction of the flue near the fire, it causes the chimney draught to remove the heated foul air, accumulating constantly in the upper part of inhabited rooms, from the breath of inmates, the burning of lights, the odour of food, &c., as certainly as the smoke of the fire. The valve allows passage only in one direction, like the clack valve of a common pump. It consists of a metallic plate, very nearly counterpoised by a weight beyond the axis of motion, and turning on a sharp edge, so that the slightest force can move it.]

Dr. Arnott's wind-guard, for preventing down-draughts in chimneys.

388 NETTLETON & SON, 4 Sloane Square, Chelsea—
Inventors and Manufacturers.

Gothic church-stove, with ventilating air-chamber, from which an air-flue is conducted to the external air, thus intended to introduce into the building a constant supply of pure air in a warm state.

Gothic stoves, with water vase-covers and pans, adapted for warming halls, schools, green-houses, &c.

Portable bed-room and conservatory stove, with ventilating air-chamber for admitting pure air from the exterior. The interior of this stove consists of a portable fire-pail, which on being filled with live fuel at a kitchen fire, may be closed air-tight and conveyed to the bed-room, where it will burn twelve hours, at a moderate heat, without attention.

[Air heated by contact with metallic surfaces, raised to a temperature above that of boiling water, viz., 212° Fahr., becomes dry, has its electrical condition altered, and, moreover, the decomposition of the particles of animal and vegetable matter that continually float in it, gives it a peculiarly unpleasant odour. Shallow pans of water placed over the stove may keep the air in its proper hygro-metric state, but its other conditions are not thus maintained.—S. C.]

389 COURT, JOHN, 18 Queen Street, Grosvenor Square—
Inventor and Manufacturer.

Improved hot-air stove, for warming apartments, shops, churches, &c. The novelty consists in the products of

combustion being made to pass between two earthen cylinders, so constructed as to traverse a distance of 20 feet, by which nearly the whole of the caloric is abstracted before they enter the chimney.

Hot-air stove, heated by gas; constructed on the same principle.

390 TOZER, THOMAS, 55 *Dean Street, Soho*—Inventor and Manufacturer.

Ventilating gas stove for halls, shops, &c. It can be erected with an ascending or a descending pipe, and so constructed as to prevent any return draught from extinguishing the gas.

The bachelor's kitchen, a portable cooking apparatus, adapted for small families, pic-nic parties, sportsmen, and others.

Registered calorifere, or hot-water vessel; to be used as a bed-airer or a foot-warmer in house or carriage.

391 NORMAN, GEORGE, 5 *St. Ann's Place, Limehouse*—Inventor.

Improved cooking stove for the use of private families; to stand in a common fireplace, and requiring no fixing.

393 FROST, HENRY, 17 *Rathbone Place*—Inventor and Manufacturer.

Model kitchen fire-place and cooking apparatus, calculated to roast, bake, &c., with one small fire; and applicable to various other purposes.

395 HEWETT, H. BRIXEY, 308 *High Holborn*—Inventor.

Machine for rapidly cooling or warming liquids, and combining the two processes in one vessel. Of domestic importance, in its capability of preserving milk, cream, &c., from turning sour.

396 KENT, JOHN, 8 *Elizabeth Street South, Pimlico*—Inventor, Designer, and Manufacturer.

Improved vegetable cullender.
New potato steamer.

397 PRICE, VINCENT, 33 *Wardour Street, Soho*—Inventor, Designer, and Manufacturer.

New patent washing-machine. Suet and herb chopping-machine.

Ventilator; consisting of a perforated metal tube, to be placed above the window or door.

Patent pen-cleaner. Letter-copying machine. A fire-shovel with a double bottom. Patent fork-cleaning machine. New patent invented knife cleaner.

Portable stove for heating flat irons, consisting of a cast-iron box, with a sloping front and sides, a grating at the bottom to admit of draught, and an opening at the back to let out the smoke. The irons rest on a bar round the bottom of the stove, and the fuel is put in through a small door at the top.

Newly-invented patent candle-snuffers, consisting of a cylinder in two parts; the front part is fixed, and the back part is drawn back with the fore-finger; when this is released the two halves are drawn together by a spring, and the operation is performed.

399 ROPER & SON, 68 *Snow Hill*—Manufacturers.
Patent japanned plate-warmer.

400 REEKES, JOHN, 50 *Harker Street, Chelsea*—Inventor.
Portable oven, on a new principle; it can be used in the open air.

401 TYLOR & SON, *Warwick Lane*—Manufacturers.
Garden-engines and syringes, with improvements in the pumps, &c.

Improved cocks for steam, hot and cold water.

Lift and force pump; with highly finished barrel, mounted on a cast-iron standard.

Copper bath, enamelled to the appearance of white marble, in a mahogany frame, with cocks, for hot, cold, and waste water, and fitted with a copper shower-bath, and pump for the supply of warm or cold showers. This bath with a small stove for heating it, is represented in

the cut. The dotted lines show the form of the interior arrangement of the pipes, pump, &c.

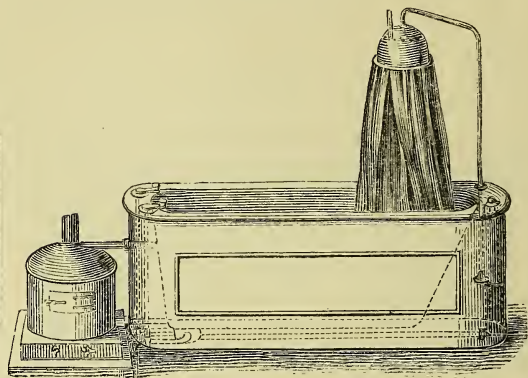

Tylor and Son's Enamelled Copper Bath.

An ornamental tea-urn of simple and chaste design. This is represented in the adjoining cut. Fig. 1.

A copper coal scuttle of new and simple design. This is also shown in the cut. Fig. 2.

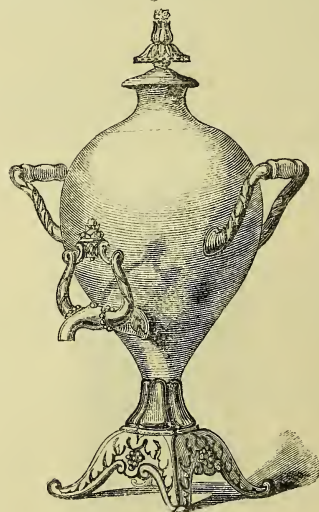

Fig. 1.

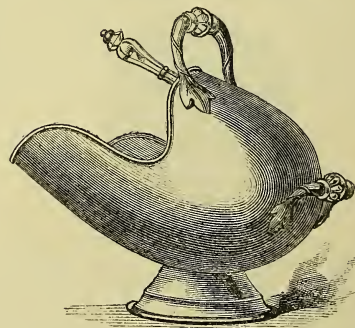

Fig. 2.

Tylor and Son's Novel Tea Urn and Coal Scuttle.

Copper coal scoops, exhibiting the changes in their patterns during the last 70 years.

Copper tea-kettles of various patterns, with glass handles and other improvements by the exhibitors.

Set of standard imperial weights and measures.

Bath apparatus, complete, with pipes, cocks, and boiler united in one frame, which requires no fixing.

Series of tea urns, containing specimens of the different improvements from 1780 till the present time.

Series of vases, beaten out of the flat pieces of copper,

without any joint or brazing. The change of form which each vase undergoes in manufacture, is shown by specimens of the vases at different stages.

402 WARREN, GEORGE, 15 Lower Market Street, Woolwich—Manufacturer.

Model of register stove. Model of thermometer stove.

403 ALDERTON & SHREWSBURY, Hastings—Designers and Manufacturers.

Hot-air stove, with open fire; the iron made from ore obtained and smelted in Sussex.

The smoke is made to pass towards the front, returning into the flue at the back, after spreading itself over the whole of the top; great additional heat is derived from a large radiating surface. By a simple contrivance, attached to the fender, the consumption of fuel is regulated by the supply of air to the bottom of the stove.

404 ARGALL, JOHN & WILLIAM, St. Agnes, Cornwall—Inventors and Manufacturers.

Cooking apparatus, designed to save fuel.

405 GRAY, JAMES, & SON, 85 George Street, Edinburgh—Inventors and Manufacturers.

A new radiating and reflecting stove grate, with flue passing up the back of the concave front, and thus transmitting a large amount of heat into the apartment. The prevention of smoke is effected by causing nearly all the air which enters the chimney to pass over the fire, and only a small quantity, absolutely required for combustion, to pass through the fire. Command over the combustion of the stove is obtained by regulating the admission of the air which passes through the fire.

The annexed engraving represents this stove grate with its concave front, &c.

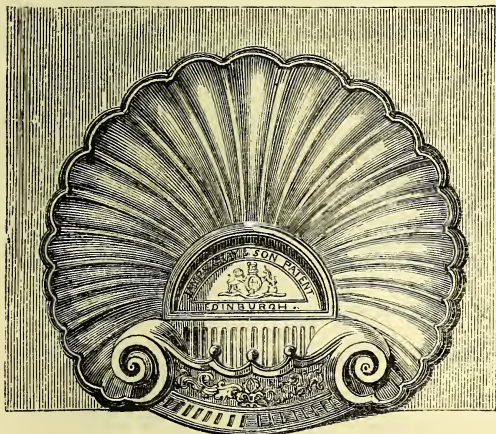

Gray & Son's Radiating Stove Grate.

A double-action bank safe lock, in which the key is made with two bits, one of which acts upon the upper levers and disengages the upper lock, while at the same instant the other bit acts upon the under lever and disengages the under lock. The security is still further increased by the impossibility of opening the one lock without the other.

406 HUXHAMS & BROWN, Exeter—Inventors and Manufacturers. Agents, TOOTAL & BROWN, 73 Piccadilly.

Improved cooking-stove, 5 feet long, with a new contrivance for roasting in the oven and for heating the hot plate on either side.

Improved cooking-stove, with a long roasting fire and other advantages; the roasting may be effected in the oven or before the fire. With provisionally registered improvements.

Emigrant's or cottage stove, suitable for wood or coal, with hot-plate and oven.

[The cooking apparatus produced by the exhibitors has a new internal flue to the oven, which is complete without fixing, and gives heat to the oven from all

its sides; whereas, on the usual plan, only one side heats the oven. This apparatus can be used as a close stove, and, by means of a winding cheek, can be contracted so as to suit the smallest effective quantity of fuel. By means of a front ventilator, and a pipe at the back, the peculiar flavour of oven-baked meat is removed. The hot plate over the oven is adapted for the purposes of steaming and ironing, being kept so hot by the peculiar construction of the flue. The apparatus can be made to bake, boil, stew, steam, and roast at the same time, and in large quantities, if necessary. It can also be made to act in every respect like an open kitchen-range, and effects a vast saving in fuel.]

407 KING, S., 1 South Hays, Bath—Inventor.

Registered ventilating and smoke-consuming register stove grate.

Model of the grate, with the exhibitor's octangular wedge bricks, showing one continuous smoke-vent from the fire to top of chimney-shaft.

Octangular wedge bricks, for forming circular smoke-flues, water and air-drains.

408 McSHERRY, MICHAEL, 3 James Street, Limerick, Ireland—Inventor.

Tin model of a registered stove, made of metal and box-plate iron, for heating conservatories, hothouses, and public or other buildings.

409 BLAIR, J., Scotland—Inventor.

Portable couch or bedstead.

410 REDGATE, JOHN, Nottingham—Manufacturer.

Register stove grates, with registered fire-brick backs.

411 RIGBY, PETER, 167 Grove St., Liverpool—Inventor.

Portable cooking-stove, for cooking with gas generated from heated spirits. This stove is shown in the cut.

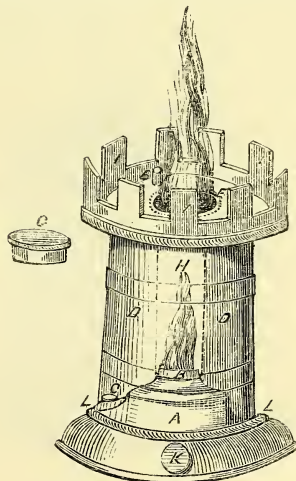

Rigby's Portable Cooking Stove.

A, the lamp for heating the boiler D. This lamp may be used with either oil or spirits.

B, the burner which heats the boiler D, and ignites the vaporized gas that issues from the holes at F.

C, the filler of the lamp.

D, the boiler, containing the spirit for evaporation.

E, the filler of the boiler.

F, the holes from which issue the vaporized spirit, which is ignited by the flame from the burner B.

G, the cap, to cover the holes, when not in use.

H, the chimney.

I, the gallery on which is to be placed the frying-pan, stew-pan, kettle, &c., while cooking.

K, The regulator, the turning of which will increase or decrease the heat at pleasure.

L, the screw to fasten the stove down upon the lamp.

Emigrant's kitchen, connected with the stove, and containing frying-pan, stewpan, kettle, plates, and dishes, &c.

412 **TIPPEN, JOHN, Chichester**—Inventor and Manufacturer.

Model of a new bedstead, constructed so that an invalid can be raised to any required position.

Model of an improved kitchen range, with two boilers and taps, oven, steam closet, and hot plate, swing vane and shifting hooks, smoke-jack with chains, cradle and bird spits, draw fret, fender with slide top, ash grate, &c.

413 **WALLACE, JOHN, & SON, Leith**—Inventors.

Model of a patent safety cooking apparatus for ships, by assistance of which many dishes may be prepared at the same time, and at a small expense for fuel.

Model of improved ventilator for warm climates, constructed to admit air, and prevent the entrance of insects, &c.

414 **STOCKER, —, Manufacturer.**

Specimen of metal castings.

416 **MASSEY, W., & Co., 58 Baker Street, and 5 King Street, Portman Square**—Manufacturers.

Stands for flowers, of different sizes, made of brass tubing, by hand.

418 **M'KENZIE, ALEXANDER, 38 De Beauvoir Square, Kingsland**—Manufacturer.

Model of condensing engine, scale $\frac{1}{4}$ inch to one foot; exhibiting the following peculiarities:—Placing coffer valves under cylinder; supplying cistern from the bottom by a force-pump; lever for reversing motion, &c.; giving motion to throttle valve.

Instrument for registering motion of all kinds, consisting of four concentric wheels. It may be made susceptible of small vibrations, in conjunction with a clock. It is to register the variations of speed, &c., applicable to paddle-wheels, locomotives, printing presses, gun-carriages, &c.

421 **HASLAM, WILLIAM, St. Helen's, Derby**—Designer and Manufacturer.

Specimen of iron church-door hinges, with branches of scroll-work, after the early English style.

422 **BOTT & ALLEN, Manchester**—Manufacturers.

Fenton's patent anti-friction metal, in ingot; a substitute for brass for the bearings of machinery, &c.

The same in casting for railway carriage axle bearings, unused; and that has been in work upon a railway, having run a considerable distance.

The same metal for machinery bearings; and applied to union joints for plumbers' work; to steam-engine valves; to ship nails and fastenings; to ship blocks, or pulleys, &c.

Dickenson and Falkous's patent equitable gas-meter.

424 **PADDON & FORD, Brownlow Meus, Gray's Inn Road**—Manufacturers.

Patent wet gas-meter.

426 **BOTTEN, CHARLES, Crawford Passage, Clerkenwell**—Inventor and Manufacturer.

Patent protector gas-meter, for preventing fire-damp, and persons from drawing off the water, so as to cause an incorrect registration.

430 **SPARKS, JOHN, 12 King Street, Tower Hill**—Inventor.

Box for the secure transit of cash on railways.

Hinge for closing lobby doors. Vulcanized rubber is used in place of a steel spring, and it can be adjusted so as to suit any door.

431 **GRANT, DONALD, Luton Place, Greenwich**—Inventor.

Patent gas-light, perfectly ventilated; the conveyance of the heated air may be carried on through wood-work,

with the absence of any danger of ignition, within a distance of one inch from any combustible material.

[If a room, 12 feet square and 12 feet high, with the doors, windows, and fire-place closed, has a gas lamp burning in it, consuming 5 cubic feet of gas per hour, the light will produce sufficient carbonic acid, in rather more than three hours, to be in the proportion of 1 part to 100 of air, and when in such condition the air is decidedly injurious to health. The removal of the products of combustion, therefore, at once into the external air, should always be provided for. The idea of ventilating gas-burners originated with Professor Faraday.—S. C.]

Stove, heated by gas, for baking bread and cooking provisions, by roasting, boiling, or broiling.

Stove that may be heated by either gas or coal. This stove gives out both radiated heat and hot air, kept in constant circulation; a supply of air from the external atmosphere also serves to support and assist combustion, and to prevent the temperature of the apartment becoming too high for the purpose of a healthy respiration.

Small model of improvements in the form and material of fire-flues, calculated to remove danger by the ignition of soot and the waste of heat.

432 **HALDANE & RAE, George Street, Edinburgh**—Designers and Manufacturers.

Gas lustre suspended from entwined branches, which are supported by two rustic pillars; a variety of gas branches being fixed on the pillars. Below, there is a wash-hand basin, and models of patent water-closets; also registered spiral taps for different purposes; vases for gas, suitable for mantelpieces, staircases, &c.

433 **RICKETS, CHARLES, 5 Agar Street, Strand**—Inventor and Manufacturer.

Gas-cooking range, with roaster, oven, stewing-stove, &c. Apparatus for stewing, by means of jets of coal-gas mixed with atmospheric air; for heating laundry irons, hatters' or tailors' irons, and bookbinders' tools.

Calorific gas stove, for warming halls, shops, churches, conservatories, &c.

Apparatus for broiling chops, steaks, &c., with jets of gas; for toasting bread, boiling water, &c., with gas and air; for heating chemists' spatula, macerating, and for sand-baths; and lighting stove fires by means of gas.

434 **COCHRANE, J., Greenside Law, Edinburgh**—Manufacturer.

Gas-meter, 10 inches diameter.

435 **SIEBE, AUGUSTUS, Denmark Street, Soho.**

Patent rotatory universal syringe, to keep up a continual flow of water.

436 **RYAN, J., 13 Stafford Street, Dublin**—Inventor and Manufacturer.

Transparent gas-meter.

437 **ROPER, JOSEPH, Wigan, Lancashire**—Manufacturer.

Transparent gas-meter, which registers the consumption of gas to the hundredth part of a foot.

438 **BIDDELL, GEORGE ARTHUR, 22 Montpelier Square, Knightsbridge**—Inventor and Patentee.

Patent self-regulating gas-burners, made for horizontal and vertical attachments. Complete section showing their construction. These burners regulate themselves to all variations of pressure, preventing the flame rising above or falling below any height to which they may be adjusted.

[When the valve at the gas-works regulating the supply to the initial main is partially closed, the flames of all the burners fall, and when a number of burners are turned

off, those which still remain lighted rise, unless in each case the stop-cocks be altered, or some contrivance used which will ensure a regular height of the flame by self-action. Probably the best means of effecting this is by using a "governor" on the service between the main and the burners.—S. C.]

438A SHEARS & SONS, 27 *Bankside*—Inventors and Manufacturers.

Patent dry gas-meter, for ascertaining the quantity of gas consumed for illumination or other purposes. The novelty of this meter consists in the application of vertical diaphragms, vibrating on vertical shafts; the use of conical seat semi-rotating valve, and the application of a peculiar shaped screw and worm wheel, by the use of which gas may be passed either way through the meter, without affecting the registration of the index.

The adjoining cut gives a representation of this meter, showing the interior of the apparatus.

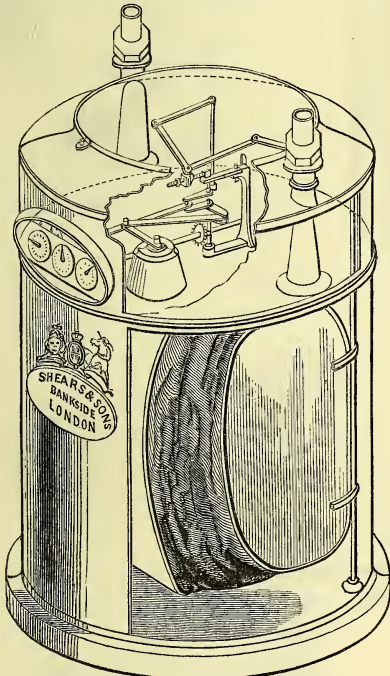

Shears & Son's Patent Dry Gas-meter.

[The water-meter, invented by Mr. Clegg in 1815, depended for its accuracy upon the water line remaining constantly at the same level, which evaporation prevented. Dry meters are intended to obviate this defect, and consist of moving diaphragms, worked by the gas passing from one side to the other, each vibration recording on a dial the quantity of gas that has passed.

The peculiarities of each kind of dry meter, consist chiefly in the different arrangements, and the number of the diaphragms and valves.—S. C.]

439 LOCKERBY & STEPHENSON, *Glasgow*—Designers and Manufacturers.

Six-light chandelier for gas.

440 HARVEY, GEORGE, *Great Yarmouth*—Inventor.

Cooking-stove, or ship's fire-herth, of wrought iron.

441 EDGE, THOMAS, *Great Peter Street, Westminster*—Manufacturer.

Patent wet gas-meter, with improved lever-valve and float, index, and waste-water box. Separate index and lever-valve, with float to show their action more clearly.

Patent dry gas-meter, having upright double-cranked shaft, and only three measuring chambers.

442 YOUNG, W., 18 & 33 *Queen Street, Cheapside*—Inventor and Manufacturer.

Vesta lamps, on tripod pedestal; and on pillar. Vesta reading and night lamps. Vesta lantern. These lamps are constructed to burn rectified turpentine.

Spirit cases, with air-tight stopper.

Vesta gas-burners, constructed to burn with internal deflectors.

443 STRODE, WILLIAM, 16 *St. Martin's Le Grand*—Manufacturer.

Gas cooking-range for boiling, baking, roasting, and broiling, on the plan of Alfred King, Esq., C.E., of Liverpool.

This cooking-range is shown in the adjoining cut, by a front elevation, with its closets, ventilators, &c.

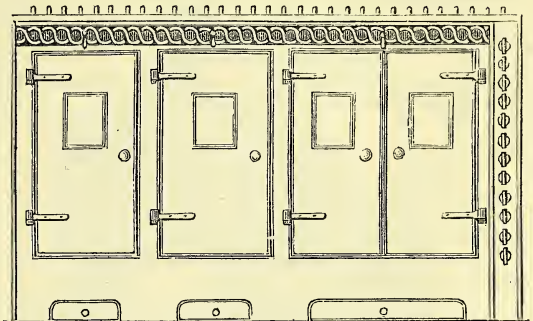

Strode's Gas Cooking Range.

Gas torch attached to the gas pipe, with flexible tube for lighting up the burners.

Gas broiler for chops, steaks, &c. This broiler is shown in the following cut, with its shelves, dampers, &c.

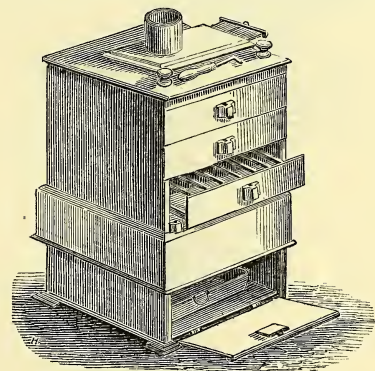

Strode's Gas Broiler.

Gas stove, being a hot-air stove heated by gas. Bronze candelabra for gas, designed by P. C. Hardwick, Esq. Holly branch made of sheet copper—a model for part of a candle branch or girandole.

Riddle's self-igniting gas-burner, by which the hydrogen light is adapted to the purpose of lighting common coal-gas. Railway signal lamp, with parabolic reflector.

Lowe's patent naphthalizer for charging gas with the vapour of naphtha.

[Coal-gas, charged with the vapour of naphtha, has its illuminating power nearly doubled, in consequence of the increased quantity of carbonaceous matter which it acquires in its passage. The employment of coal-gas for cooking will soon be universal. The ease and certainty with which the heat from the flame can be regulated, its

cleanliness, and its economy, are advantages of too great importance to be overlooked. At the proper moment for the cooking, the gas fire is lighted, and the required degree of heat obtained at once, and maintained uniformly: when the cooking is done, the fire is turned out instantly. The number of fires or gas flames can also be increased or diminished at pleasure to suit the requirements of the case.—S. C.]

444 FARADAY, JAMES, & SON, 114 *Wardour Street*—
Manufacturers.

Gas chandelier, upon Professor Faraday's ventilating principle, by which the carbonic-acid gas, soot, moisture, and other noxious products, are carried off by the descending draught. The lights are enclosed in glass chimneys, covered with plates of mica, and the burnt air passes through tubes along each arm to the body of the chandelier, and thence up the centre shaft, to be discharged into the open air, or an adjoining flue.

445 DEBAUFER, HENRY, 10 & 11 *Creed Lane*—
Designer and Manufacturer.

Concentrating gas-lamp; for externally illuminating shop-windows, on the parabolic construction.

446 CLARK, R., & RESTELL, T., 447 *Strand*—Designers
and Inventors.

Various lamps and gas-burners.
New locks.

Railway passengers' communication.

A model of a new principle in clockwork: gravitating without pendulum.

The accompanying cuts represent the various lamps adapted for use in hot climates, and for other purposes. These lamps, except where named, are intended to burn cocoa-nut, olive, and other oils.

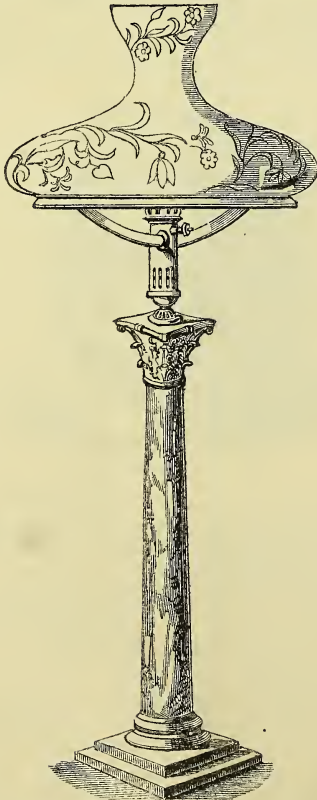

Clark's Patent Diamond Table Lamp.

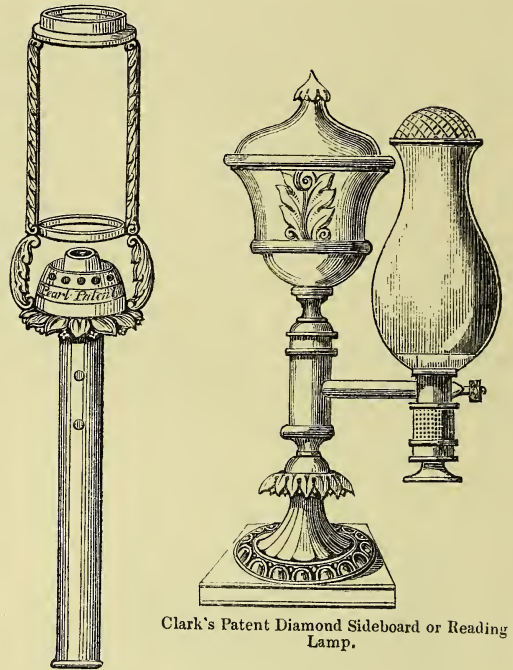

Clark's Pearl Hanging Lamp.

Clark's Patent Diamond Sideboard or Reading Lamp.

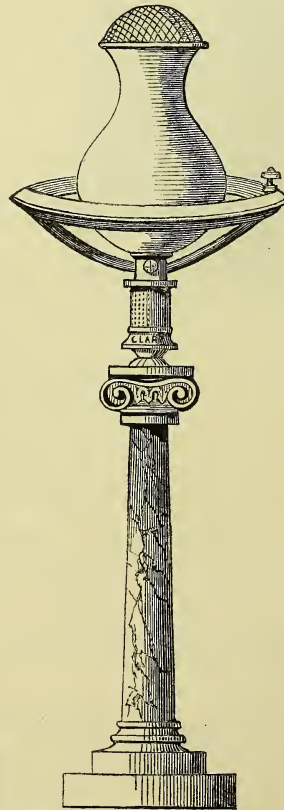

Clark's Patent Diamond Table Lamp.

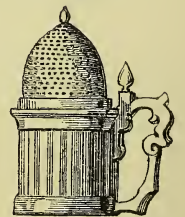

Clark's Patent Star Night Light.

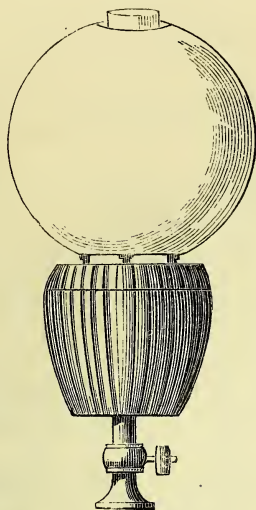

Clark's Patent Reflector for Gas Lights.

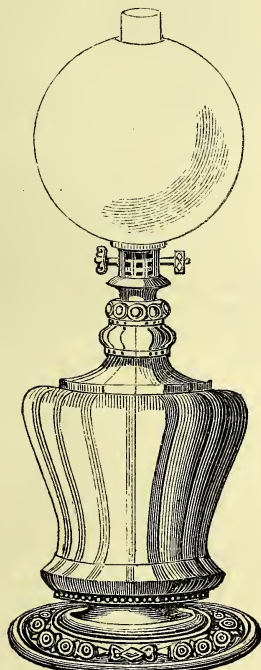

Clark's Improved Oil Lamp, with Reservoir below the Light.

447 PALMER & Co., Sutton Street, Clerkenwell—Manufacturers.

Lamps, to burn magnum candles, and designed to give the light of argand lamps.

Lamps, to burn mid-size candles, and designed to give the light of four mould-candles.

Weather-lamps, to burn candles; for warehouses, stables, and out-buildings.

448 HOLLIDAY, READ, Huddersfield, and 128 Holborn Hill, London—Inventor and Manufacturer.

Patent self-generating gas lamps for out-door uses. Lamp on the same principle, for in-door purposes. Patent signal-lights, &c., and instrument for lighting the lamps.

Sulphate, muriate, carbonate, and liquor of ammonia, naphtha, &c., extracted from the ammoniacal liquor and tar, produced by the distillation of coal. The naphtha is for the use of lamps; the ammoniacal liquor is used in the West Riding of York for scouring woollen yarns, dyeing, &c.; the sulphate of ammonia for alum, manure, &c.; and the muriate of ammonia, carbonate of ammonia, &c., for other purposes.

449 RETTIE, M., & Sons, Aberdeen—Manufacturers.

Patent distress signal-lamps, for steamers and sailing vessels in distress, invented by Robert Rettie, C.E., London. These lamps are shown complete and ready for use in the cut annexed.

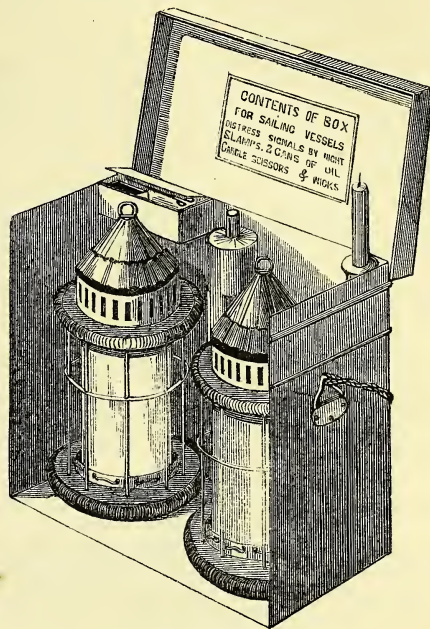

Rettie's Patent Distress Signal-Lamps.

Patent signal-lamp, for preventing collision of vessels and steamers at sea.

450 HOLGATE, JAMES, 6 Arthur Street East—Inventor and part Designer.

Registered improved hand-signal lamp, to show red, green, and white lights. Another, with the green and red glasses revolving inside the case.

Tail-end signal lamp, for railways, with bronze head, and registered china reflector.

Registered buffer lamp for engines, showing a white light. A red glass revolves in the interior, to convert it into a danger signal when required. Patent glass reflector.

Buffer lamp, with parabolic reflector.

Gauge lamp for engines, constructed to answer also as a danger hand-signal lamp for engine-drivers.

Patterns of handles, hinges, locks, bolts and nuts, curtain panels, curtain rods, escutcheons, and all other articles in hardware required in the construction of railway carriages.

451 SQUIRE, RICHARD, 16 South Street, Manchester Square—Manufacturer.

Pair of plated basterna carriage lamps. Pair of carriage lamps.

Railway roof lamp, with new key burner for simplicity in trimming.

Railway tail lamp, with moveable head, intended to clear out corroded soot.

Hand signal, containing extra large burner. Foot-board lamp for carriage. Improved magic lantern.

Travelling Etna, intended to boil water in three minutes.

Improved lamp for singeing horses.

452 SMITHS & Co., *Blair Street, Edinburgh*—Designers and Manufacturers.

Stationary railway-signal, lantern, and lamp. The air is admitted through holes in the bottom of the lantern, and closed during high winds by a sliding cover working from the outside. The heated air escapes by a vane moving on the top. The lamp has a flat wick, which can be raised and depressed without making its surface unequal, and thus causing smoke. The saving in the consumption of oil is stated to be nearly one-half.

A lantern and lamp for the head or tail of a railway train. The colours of the light can be changed by bringing coloured glasses between the flame and the outer lens. The lamp has an argand burner, with a new and simple plan for fixing the wick-raiser, and preventing the wick from shaking down by the motion of the carriage.

A railway-carriage roof lamp, of a new construction, by which the oil does not overflow, and the light is kept steady.

A stage-coach lantern and lamp, with reflectors of a composition metal free from tarnish, and giving a clear white light.

Hand signal-lamp for a railway, with a red and a green slide for changing colours.

453 BIGGS, SAMUEL, *Frome, Somerset*—Designer and Manufacturer.

Tin moulds for jelly, blanc mange, rice, Savoy cake, raised pie, patties, Italian cheese pudding, &c. Plain cutters for paste and vegetable. Root cutters. All made by hand.

455 SAUNDERS, WM. JOHN, 11 *Polygon, Clarendon Square*—Inventor and Manufacturer.

Pneumatic solar lamp for railway signals, lighthouses, and domestic purposes, said to be equal in intensity to that of gas, adapted for the combustion of common oil, either animal or vegetable, and free from noxious effects.

458 BRIGHT, RICHARD, 37 *Bruton Street*—Inventor and Manufacturer.

Various lamps. Patent lamp wicks, cistern-top, or floating cover, to prevent the action of the atmosphere on oil or other liquids.

459 CHILDS, JAMES, *Brentford*—Manufacturer.

Brass fountain lamp, with four-wick adjusting concentric burner, for a lighthouse lantern.

461 HUGHES, JOHN GEORGE, 158 *Strand*—Proprietor.

New designs for lamps to burn candles of various sizes. Inkstand, bronzed (boy holding torch). Three-light candelabra, bronzed. New design for a gem spirit-lamp. Lantern for a hall. Flower-stand tripod, lacquered. New design for an oil-lamp. Candelabra, lacquered. Three-light gas chandelier, fuchsia pattern.

Model of a marquée.

462 BARLOW, JAMES, 14 *King William Street, Mansion House, City*—Inventor and Manufacturer.

An illuminator, or vault light, illustrating a method of admitting daylight into vaults, ships' decks, underground apartments, &c.; the apertures are each filled with a lens of peculiar construction for the admission of light.

Newly-invented self-acting syphon tap.

464 BLACK, BENJAMIN, 49 *South Molton Street*—Manufacturer.

Ornamented carriage lamp.

465 PYRKE, J. S., & SONS, *Dorington Street*—Manufacturers.

Bronze tea-urns and swing tea-kettle, of new designs.

470 SARSON, THOMAS FREDERICK, *Leicester*—Manufacturer.

Gas lamp, with ornamental construction for ventilation.

472 NIBBS, JAMES SYSON, *Baslow, Blakewell*—Inventor.

Forms of the "oxidate condensing lamp," for the economical distribution of artificial light. The burner is constructed to effect the combustion of the whole of the carbon of the oil, and is said to produce a greater amount of light from a given quantity of oil. The common oils may be used.

Improved weather lantern, for out-door purposes, cellars, &c., constructed on the same principle, with other improvements; and used for ships, railway carriages, and other vehicles, as side lights, &c.

474 HAWKINS, JAMES, 42 *Bow Street, Dublin*—Manufacturer.

Circular silver-mounted Clarence carriage lamps, for spirit or candles.

476 DOWSON, JOSEPH EMERSON, 123 *Oxford Street*—Manufacturer.

Cundy's patent hot-air ventilating stove. The interior is made of fire-clay, and no surface iron comes in contact with the air. The fresh external air is admitted to the interior of the stove, there warmed to a moderate temperature, and then passed into the apartment, by which a stream of pure warm air is supplied.

477 BROWN & REDPATH, *Commercial Road, near West India Docks*—Patentees and Manufacturers.

Fire hearth, or cooking apparatus for ships' use. This specimen will cook for 56 seamen and 30 passengers. The whole of H.M. steam ships are supplied with these hearths, which can be made to cook for 1,000 men, and are used in first-class passenger ships to India.

Specimens of the most approved lanterns used for marine purposes.

479 CALLAM, THOMAS, 56 *Shore, Leith*—Inventor.

Model of a ship's cooking apparatus, in various sizes. Economy in fuel is stated to be attained by the use of a damper, moved at the side under the chimney; this, when pushed in, closes the draught under the boilers, or coppers, as they are technically called, and opens it at the side; when drawn out, the side-port is shut, the main flue opened, and the flame makes a circuit under the coppers before reaching the chimney. Baking, boiling, roasting, and steaming may be all performed at the same time.

480 SEARLE, CHARLES, M.D., 51 *Weymouth Street*—Inventor and Patentee.

Tubulated solid stove or heat condenser, for warming libraries, schools, passages, shops, &c. The heated gases of the fire in their passage to the chimney pass through a lengthened tubulated solid mass of fire-brick, constituting the body of the stove.

Fire-bricks, with porcelain surface, and in iron casing of two forms.

481 GOODBEHERE, GEORGE THOMAS, 9 *Wellclose Square*—Manufacturer.

Improved ship's hearth, constructed to cook for fifty men; containing furnace, so arranged that an admission of air is obtained between the fire and the oven, to prevent the latter from being burned through, and to save expense in repairs. It will boil, bake, roast, and steam with despatch. This hearth is represented in the cut in the next page.

Description of the ship's hearth:—1. Funnel-pipe; 2. steamer; 3. boiler; 4. damper handle; 5. guard-rail; 6. side-damper; 7. hot-plate; 8. front door to furnace; 9. side door to furnace; 10. ash-pan; 11. oven.

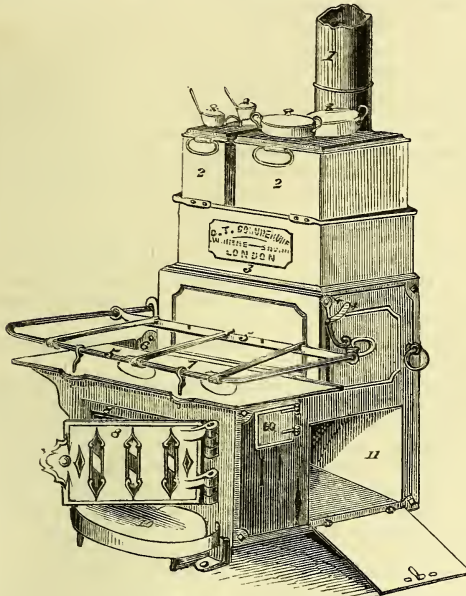

Goodbehere's Improved Ship's Hearth.

[The most extravagant domestic apparatus is the ordinary kitchen range, the quantity of non-effective coal consumed being enormous. To produce the utmost effect from fuel, the heat must be retained in flues around the substance to be cooked as long as it imparts heat, and only suffered to escape by the chimney when it is too cold to be of service. Count Rumford says (Essay x. p. 31), "More fuel is frequently consumed in a kitchen range to boil a tea-kettle than, with proper management, would be sufficient to cook a good dinner for fifty men." The more space and fuel ships' hearths economise, the more effective they are.—S. C.]

The emigrants' hearth, which can be made to any size required.

482 DEFRIES, NATHAN, 221 Regent Street—Inventor and Patentee.

Diagrams, illustrating a bath heated by gas, gas works, and a new mode of lighting, heating, and ventilating conservatories and buildings.

Gas stoves for warming and ventilating rooms and buildings, and for culinary purposes. By means of one of these stoves, a person may roast, boil, bake, steam, and stew at the same time.

Patent gas bath, by which 45 gallons of water may be heated in six minutes, from 45 to 90 degrees Fahrenheit, at a cost of less than 2*d.* for gas. This invention consists in the application of jets of gas acting on metallic plates at the bottom of the bath, by means of a simple apparatus.

[The process of making coal gas is this: Bituminous coal is thrown into a retort, heated to redness, and closed up, with the exception of a pipe which leads the evolved gases and other volatile products to the condenser, where, coming in contact with cold surfaces, certain impurities are thrown down. The remaining gases then pass through the scrubber, filled with ashes, or any material presenting a large surface, by which oily matters, &c., are separated. The wash-vessel brings the gases in contact with water, when soluble impurities are removed, the lime in

the purifier finally taking up sulphuretted hydrogen. The gas, fit now for illumination, is measured by the meter, and stored in the gas-holder, from whence it is distributed through the street mains to the burners.—S. C.]

Gas-works, showing the whole process of gas-making, from the retorts to the burners, illustrating the passage through the new condenser; the scrubber, the washer, the wet lime purifier, the new rotary dry lime purifier, and the dry lime purifier in present use.

Dry station meter, formed almost wholly of glass, to show its action, and thence through a telescope gasometer to the street mains. Patent conservatory, with entirely new mode of heating, lighting, and ventilating conservatories, churches, and any other public and private buildings.

[Heating by means of a gas flame is economical, cleanly, and safe; economical, because the required amount of heat can be given at once, and the gas turned off when the purpose has been effected; cleanly, because there is no dust or ashes; and safe, because there are no sparks and no soot formed, by which a chimney flue can be inflamed.—S. C.]

The patent dry gas-meter is constructed of all sizes from one to one thousand lights; the latter size, which was made for the new House of Commons, passes ten thousand cubic feet of gas per hour.

483 GARTON & JARVIS, Ereter—Inventors and Manufacturers.

Improved universal cooking apparatus, or range-stove, including mantelpiece, with oven, hot-closet, and hot-plate, and expanding and contracting fireplace.

Exonian cooking apparatus; cast oven, hot-closet, with large ventilated roasting-chamber, dripping-pan to draw out, hot-plate, and rings and covers for broiling.

Portable cottage cooking-stove, with oven, hot-plate, boiler, and draw-off cock.

Wrought-iron cylindrical hot-house boiler, being a cylinder of water with fireplace in the centre, and a thin sheet of water at the end.

Solar, or convolute hot-house boiler; is a sheet of water coiled in the form of a scroll, with fire in the centre, and fixed horizontally.

Double vertical hot-house boiler (cast), with the fire in its centre; the flame, leaving the lower boiler, impinges on the crown-boiler.

Model hot-water apparatus, for warming hot-houses, conservatories, churches, and private residences.

Working model double-action hydraulic cider-press.

486 HALE, THOMAS, & Co., Bristol—Designers and Manufacturers.

Ornamental and Gothic swing gas-brackets; also, water-slide chandeliers in brass, bronze, &c. New registered designs, in tinted glasses, for the same.

One of these ornamental brackets is shown in the annexed cut.



Hale and Co.'s Ornamental Brackets.

Registered improved plunge and beer-cocks. Set of musical-clock bells; set of eight-day and thirty-

hour clock bells; set of house-bells. New plan for steam lacker machine, with model.

Brass and copper tea-kettles. A newly-invented kettle for warming water, being suspended from a bar of the grate. New designs for coal scoops.

Registered copper bath, made to suit the natural position of the body when in a sitting posture; to be heated by gas or other means.

Brass figures (a Roman gladiator), bronzed, and (a flying Mercury) in a new style of lacker.

487 HODGES & SONS, *Dublin*—Manufacturers.
Copper kettles and lamps.

488 LOYSEL, EDWARD, *34 Essex Street, Strand*—Inventor.
New coffee filters. The invention consists in obtaining a vacuum in the coffee-pot, without expense, by the condensation of steam.

Potato roaster of a new description, which may be used either in the kitchen or in the parlour.

489 KEPP & Co., 40, 41, & 42 *Chandos Street, Charing Cross*—Manufacturers.

Copper bath, with set of cocks complete, and shower-bath over. Steamers, for fish, meat, and vegetables. Range-worm, or coil of tinned-copper hot-water pipes. Copper skylight frame. Copper covering for roofs. Moulded copper cornice-gutter, with moulded cistern-heads and rain-water pipes attached. Hot-water boiler for circulation. Double meat-boiler, tinned inside. Dish-washer, tinned inside. Moulds for jellies, cakes, &c. Brass ornamental lantern. Two ornamental copper vanes; the ornamental work raised by hand. Copper saddle-boiler. Ornamental wrought-copper easement. Copper clock-hands. Zinc and copper chimney pipes.

490 WILSON, R. & W., 49 *Wardour Street, Soho*—Designers and Manufacturers.

Ornamental shower-bath of tinned iron, half circular form, fitted with mahogany seat; the same, of a square form.

Plunging-bath, with shower combined, of tinned iron. The same, fitted with taps, plates, and levers, to supersede mahogany fittings. Roman plunging-baths. Ornamental hip-baths. Child's nursery-bath, with loose frame.

491 NOIRSAIN, JULES, *Hamstead House, St. John's Wood*, and 131 *Regent Street*—Inventor.

Patent ventilating open fire-place, with chimney-glass and ornaments; the chimney-piece and frame, of glass, are made of black marble in the Louis Quatorze style; the room is ventilated by means of an aperture behind the top ornament of the glass frame; from this aperture a pipe conveys the vitiated air of the room into a chamber at the back and sides of the grate, from whence it passes into the chimney. The panels, or front of the fire-place, are made of beaten copper, highly polished.

In order to ensure health and comfort in the heating of an apartment, various conditions are required: 1st. That the grate which warms the apartment (from 50 to 65 degrees being the most advantageous temperature) should produce a perfect ventilation or change of air, both in the upper and lower part of the room. To obtain this, the action of the heat and of the air for ventilation must be so combined as to be dependent one upon the other, and to act together.

It is also essential to health that the air should be perfectly free from all smell, smoke, and gas, arising from the fuel. To obtain this, the bars of the grate must not project beyond the opening of the fire-place, and that opening should be smaller than the sectional diameter of the chimney; by which means any chimney, however defective in construction, will be prevented from smoking.

2nd. It is necessary that the heat should be equally dispersed throughout the apartment, so that there should be no draughts. For this purpose the air should be

allowed to escape from the room not only up the chimney from the lower part of the room, but also from the upper part, through another opening leading to the chimney, thereby causing free circulation of the air throughout the whole of the apartment.

In order that the apartment may be sufficiently heated, it is not necessary with these stoves to make up a large fire, by burning a large quantity of fuel, but the intensity of the fire should be increased by the application of a draught-plate (made of glass or wire-gauze) to the opening; a pipe is also placed in the chimney, and communicates with the ventilating or hot-air chamber, at one end, and with the upper part of the apartment at the other, in order to throw out warm air into the upper part of the room.

On the other hand, in order that the apartment should not be overheated, a double-action valve is placed at the lower part of the fire-place, and communicates with the pipe in the chimney; by this means the opening, instead of throwing out warm air, is made to draw off the hot and vitiated air from the upper part of the room when required.

To ensure safety, by preventing a chimney from taking fire, care should be taken that the smoke be not allowed to become condensed in the chimney; to prevent which, the opening should not be too high, so that the air to support combustion may be well heated before ascending the chimney and mixing with the smoke; if the opening be too high, the air would enter at too great a distance from the fire to become sufficiently warmed, and consequently the smoke would condense and form soot.

The accumulation of soot at the sides and back of the register cannot take place in the improved system, as is often the case in the ordinary construction of a grate. Also, in the old plan, the flame is allowed to act upon the sides of the chimney to which the soot adheres; but in the improved system the fire is contained in an iron case, from three to four feet high, which does not touch the chimney; thus leaving a hollow space outside for the reception of the soot (if any is formed), and removing it from the part where flame is allowed to exist.

For the convenience of sweeping the chimney, a small door or opening is provided; by this means the chimneys are better swept, and the inconvenience of having the sweeps and soot-bags in the apartment is avoided.

A considerable economy is obtained by thoroughly heating an apartment with the least possible expenditure of fuel. For this purpose there must be a due proportion between the size of the outlet for the smoke from the case and the area of the grate, and, consequently, of the quantity of fuel consumed.

Cleanliness is insured by the employment of a moveable ash-pan, projecting a considerable distance from the fire, and independent of the fender.

The improved grates and fire-places may be made of various forms and designs, so as to accord with the chimney-piece and other architectural embellishments of the apartment, on the well-known principle that the frame for an object should be made to form, at the same time, an ornament, thus making a harmonious whole.

Ventilating open fire-places, made of porcelain, in the form of a pedestal, to be placed in a recess under a chimney, and having the panels made of ornamental porcelain; the same of bright polished copper, adapted to a pilastre.

493 GILESPIE & SON, 62 *Broughton Street, Edinburgh*—Inventors and Manufacturers.

Model of the Victoria shower-bath; the reservoir moving up and down on pulleys.

494 GILBERT, SAMUEL, *Ironmonger Street, Stamford*, *Lincolnshire*—Inventor and Manufacturer.

Registered Soapant bath. Exhibited for elegance and utility.

495 MCGRIDGE, M., *The Willows, Swansea*—Inventor.
Model of a sponging bath.

496 HARDWICKE, WM., 32 *Hatton Garden*—Inventor.

A portable domestic bath-room, with warm and cold water cisterns attached; the water is heated by a flow and return pipe, in connexion with a small stove placed in the nearest adjoining fire-place; the water may be warmed, and the room lighted and ventilated by gas.

498 MOSS, RICHARD, *Bartholomew Square*—Inventor and Manufacturer.

A registered copper vapour-bath, with internal trough and box for herbs, &c.; fitted upon a stand (oak and vine), cast in copper, mounted by a twined leaf, with glass handles; worked by a spirit-lamp, with glass handle, a turned leaf forming the thumb-piece. Medicated vapour can be applied by this instrument.

499 DAWBEE & DUMBLETON, *South Town, Yarmouth*—Inventors.

Working model of a stone filter in a slate cistern.

500 BRAY, CHARLES, 14 *Cranbourne Street, Leicester Square*—Inventor.

Square pedestal wash-stand, of papier maché, japanned, and ornamented with gold mouldings; the interior fitted with metal cistern for water, and reservoir for waste; basin, soap dishes, &c. The same, circular, made of metal, japanned.

Pillar shower bath, with reservoir, curtain, and pan complete.

The "anhydroepseterion," for dressing potatoes, with a tin lining, which may be placed inside, for hashing or stewing.

Potato and spoon warmers. Plated rests for a carving knife and fork, with useful appendages. Crumb tray, made of tin japanned. Portable machine for boiling water.

501 DALE, RICHARD, 195 *Upper Thames Street*—Manufacturer.

Model of a warm bath and heating apparatus, consisting of a copper bath, tinned and japanned, with a cylindrical copper boiler, so constructed that on filling the bath with cold water the boiler is charged, and on lighting the fire the water circulates from the boiler to the bath until it arrives at the required temperature, when the fire may be lowered by means of the ventilators, or extinguished by dropping the grating, and the bath may be used. The boiler is so formed that the fire acts directly on its sides and dome, which are entirely surrounded with water.

502 FAULDING, JOSEPH, 11 *Edward St., Hampstead Road*—Inventor and Producer.

Specimens of ornamental and curvilinear sawing; for embellishing pianofortes and cabinet furniture, and for architectural ornaments; patterns for castings cut with the requisite bevil for moulding.

Registered portable vapour bath; for the local or general application of steam-heat to the human body.

503 LONGFIELD, WILLIAM, *Otley, near Yorkshire*—Inventor and Manufacturer.

Ornamented wrought-iron safe or chest, for deeds, &c., with patent positive security lock, having fourteen reverse bolts, moved by one turn of the key, and an improved nest of drawers and desk, rising out of the chest.

504 MATHER, J., *Chelsea*—Inventor.

Bath of improved construction.

506 LEADBEATER, JOHN, 125 *Aldersgate Street*—Manufacturer.

Banker's fire-proof safe.—Fire-proof repository, affording security against the skill of burglars; and resisting, in cases of fire, the falling of heavy materials.

507 TANN & SONS, *Minerva Terrace, and Hope Street, Hackney Road*—Patentees and Manufacturers.

Specimens of patent fire-proof iron safes, with outer and inner doors fitted with patent reliance locks. Security

from fire is obtained by filling hollow chambers with chemical salts, capable of resisting the action of fire unless it is increased to a great degree. The salts become fused, and by throwing off moisture afford protection to the contents of the safe. Fitted up as a cabinet and writing desk.

[To render a safe "fire-proof," it is not merely necessary that it be made of non-combustible material, such as iron, for being quick conductors of heat, a temperature capable of charring the contents is speedily communicated when the outside is in contact with burning substances; it becomes, therefore, essential that some matter capable of resisting the transmission of heat be placed between the iron outside and the things within, which are to be preserved from fire.—S. C.]

508 FISHER, JOHN NORTH, 10 *Charles Street, Manchester Square*—Inventor.

Safety boxes for collecting money bags in railways; also for counting-houses and offices for private letters, &c.

509 BAKER, CHARLES, *Jireh Cottage, Rotherfield Street, Islington*—Inventor.

Fire-proof safe, on a new principle. Patterns of a new oval hair-brush, and of a pocket tooth-brush. Model of a writing-desk.

510 MARR, WILLIAM, 52 *Cheapside*—Manufacturer.

Wrought-iron patent fire-proof strong room, secured with the double chamber wheel-action detector lock.

516 ROSINDALE, C., *High Street, Hull*—Inventor.

Service-box, applicable to every description of water-closet, and not requiring the cistern direct over head.

517 CLARK, C. CHAPMAN, *Reading*—Inventor.

Registered self-acting sanitary water-closet.

Self-acting valve trap for sinks, &c., proposed as an improvement on the bell trap.

518 GRAY, THOMAS H., 79 *King William Street, City*—Inventor and Manufacturer.

Patent inventions of different descriptions. Spherical pump; sanitary cistern for cleansing drains and sewers; self-closing or other valve cocks for high and low pressure; vent-pegs; deck-illuminating ventilator; water closets; models of side ports or scuttles; anchor stopper; lightning conductor; wash-hand basin, with self-closing cock; sink apparatus for cleansing drains and sewers; lubricator; hydrant, or fire-cock with stand pipe.

519 HODGES, THOMAS, *Abbey Street, Dublin*—Designer and Manufacturer.

Church bell. Farm bell, embellished with agricultural devices. Altar bell, fixed on an emblematic stand carved in Irish bog oak. Large and small brass force and lift pumps, mounted on oak plank, with copper air vessels. Metal pump, with brass working boxes, similarly mounted.

Patent composition pipes for fluids or gas, from $\frac{1}{4}$ to 5-8ths of an inch, in single lengths, varying from 500 to 1,000 feet each.

520 TURNER, EDWARD W. K., 31 *Præd Street, Paddington*—Inventor.

Model to illustrate the application of centrifugal force to the purification of water in large quantities, for the supply of cities, towns, &c.

522 DAVIS, C. C., 12 *Walcot Street, Bath*—Inventor and Manufacturer.

Portable waterfall, a metal vessel of large capacity, for cleansing water-closets, sewers, &c., preventing them from being stopped, or forcing them open when stopped.

523 McCULLUM, J., 79 *George Street, Edinburgh*—Inventor.
Spirit-meter, for measuring liquids by index.

524 GUEST & CHRIMES, *Rotherham Brass Works*—
Manufacturers, Patentees, and Proprietors.

Tubular water-closet, with ornamental cast-iron base and back, in dull and bright gold; the arms and top of the back stuffed, and covered with embossed crimson velvet, and furnished with porcelain basin and tube; the piston cock forming the working part of the apparatus. Invented and registered by William Kirkwood, of Edinburgh; improved by the exhibitors.

Hydrant or fire-cock. Cast-iron box or case, enclosing self-acting ball valve, of solid gutta percha, closed by the pressure of water against a vulcanized India-rubber seating. Stand pipe to the same, of copper tube, with revolving discharge pipes, screwed for connecting to leather or other hose. Of great utility in large towns. When supplied with water at high pressure, it is instantly available for extinguishing fires, and for street cleansing. —Patent belongs to Messrs. J. Bateman and Alfred Moore, of Manchester.

Chrimess's patent hydrant or fire-cock, similar to the preceding, but with brass disc valve instead of ball.

Patent high-pressure bib-cock, having no ground surfaces; free from leakage under great pressure; and repairable by a renewal of the leather washer to the loose valve; with other advantages. The same, cut open to show the action.

Patent high-pressure ball-cock, easy in action, and requiring only three or four inches rise or fall of water in the cistern. Patent high-pressure stop-cock.

High-pressure double-valve cock, which can be repaired without requiring the water to be taken off. The same, cut open to show the action.

[When water is allowed to run through a pipe, and is then suddenly shut off, it produces a violent shock, similar to that which would occur in the sudden stoppage of the motion of a solid body, frequently causing the fracture of the pipe, particularly when the pressure column is high.—W. D. L. R.]

524A GUEST, JOHN & WILLIAM, *Little Hampton Street, Birmingham*—Manufacturers.

The following articles all gilt:—Cornelian tazza, with stand; onyx tazza, with figure. Goat inkstand, with ruby bottles; tortoise inkstand; Elizabethan inkstand, with blue bottle; inkstand, with lion top. Match-box, with medallions. Vesta match-lamp, with blue glass. Casket. Octagon snuff-box. Bell, with vine-stem handle. Chanticleer bell. Bell, with oxidised figure. Almanack. Elizabethan taper-stand. Gothic candlestick. Postage-stamp box and damper. Mounted onyx cup taper-stand. Engraved flower-holder. Figure taper-stand. Chatelaines, with appendages. Match-box, with Queen figure pillar lamp.

525 WISS, ROBERT, *38 Charing Cross*—Inventor and
Manufacturer.

Patent self-acting portable water-closet.

529 ABERRY, JOHN, *29 North Street, Hackney*—
Inventor and Manufacturer.

Improved water-closet, dispensing with all cranks, wires, valves, casings, &c.; fitted up on improved principles, and fixed without nails, screws, or brads, so that it might be taken down and refixed without damaging walls, paint, or paper.

530 DOWNTON, J., *4 Conant Place, Commercial Road, Limehouse*—Patentee and Manufacturer.

Patent water-closet; its principle consists in having a force pump attached to the basin, and four valves alternately shutting against the water.

531 MARSDEN, CHARLES, *Waterloo House, Kingsland*—
Inventor and Manufacturer.

Patent ventilated thimbles. Elastic finger guards, with a silver shield; scissors, with a guide on the handle. Registered funnels for filling lamps, &c., with naphtha or spirits. Propelling apparatus for the arms and legs.

Patent rotary water-closet; and drain trap, sewer trap, and middle-sewer trap, on the same principle. Screens of marble paper for decorations.

532 GREEN, S., & Co., *Princes Street, Lambeth*—
Manufacturer.

Henry & Co.'s patent water filter on the principle of ascension. The same, in section, showing the action.

Registered syphon flushing basin and self-acting closet connexions, fitted in wood-work complete.

Else's registered beer and spirit preserves.

533 CHAMBERS & ROBBINS, *47 Carey Street, Lincoln's Inn Fields*—Manufacturers.

Portable water-closet, with improvements.

534 LAMBERT, T., *New Cut, Lambeth*—Inventor and
Manufacturer.

Flexible diaphragm valve-cock, for water; an application of canvas water-proofed by vulcanized India-rubber, which, being pressed upon the aperture in the metal casing by means of a screw, prevents the flow of water. Section in brass.

Double diaphragm valve-cock, for water. The upper diaphragm is held to its seat by the pressure of the column of water upon the lower diaphragm; this arrangement is important when desirable to open the valve its full area, by a quarter revolution of a thread or screw, as it admits of a treble thread being used. Section in brass.

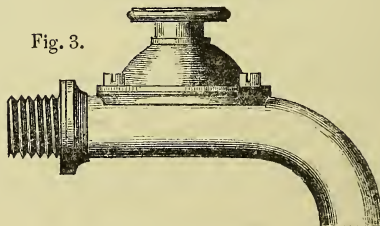
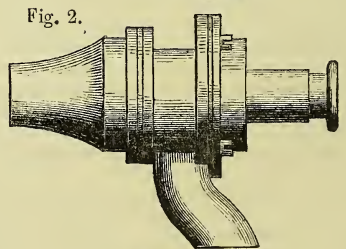
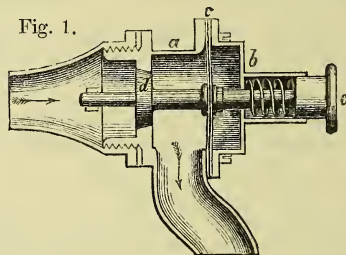

Lambert's Patent Vulcanized Valve-cocks.

Description of the patent vulcanized india-rubber water-tap. Fig. 1 shows the tap in section.

a is the body of the valve; *b* is the cover; *c* is the flexible diaphragm confined at its edges, and serving the purposes of a stuffing-box; *d* is the valve, which is held to its seating by the pressure of the water; *e* is the handle, or knob, by means of which the valve is opened: by this arrangement it cannot be left open. There are other methods for opening and closing the same; the arrows denote the waterway, when open. Fig. 2 shows the tap not in section, and Fig. 3 represents another form of the tap.

A high-pressure ball or cistern valve. A cup-leather is connected to the diaphragm, which assists the ball to resist pressure. It cannot become fixed.

A self-closing valve-cock, for water. The diaphragm is used as a substitute for a stuffing box. Section in brass. Another, the body in glass; can be made in metal. A ball, or cistern valve, of the same construction. Section in brass.

(These taps are also exhibited in Class 5, No. 478A.)

Flexible diaphragm stop-cock, in iron; with hose union; and hydrant, with iron box and lid, and union hose screw. Cheap fire cock.

Economic lamp, for the use of the artizan, which burns vegetable oil, and gives a light equal to the best candle, the cost of burning being a penny for 12 hours. The same, with centre body in glass, to show the internal arrangement. This lamp is shown in the annexed cut.

Description of the cut.

Fig. 1. A, Cap.

B, Handle for raising piston D.

C, Valve for return-oil.

E, Fixed tube.

Fig. 2. Wick and wire bodkin.

Fig. 3. Nippers.

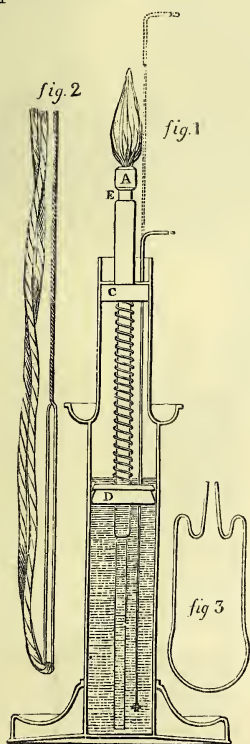

Lambert's Economic Lamp.

A self-acting water-closet apparatus, connected to the main water supply. Another, in which the valve admits the water supply, and is acted upon by the door. A blue basin closet, and valve affixed.

Samples of tin pipe made from Cornish tin. Specimens of gun metal steam-cocks and locomotive fittings.

A double cone union joint, for connecting pipes without the aid of solder.

535 PRICE, —, Inventor.
Patent washing machine.

536 DAVIS, JOHN BENJAMIN, 63 Roupell Street—
Inventor and Manufacturer.

Registered valve for steam, water, gas, or any other fluid, called a clear-way valve, intended to supersede the common plug-cock, especially the larger sizes.

538 ADAMS, JOHN, Selby—Producer and Manufacturer.
Improved washing, wringing, and mangling machine.

539 TASKER, WILLIAM, St. James's Road, Halifax—
Designer and Manufacturer.
Machine for washing, wringing, and mangling.

540 WILKINSON, —, —Inventor.
Improved patent mangle.

541 PEARSON, —, Leeds—Inventor.
Washing, wringing, and mangling machine.

542 TINDALL, E. O. D. L., Scarborough—Inventor.
Registered mangle, with horizontal spring pressure. This mangle is represented in the adjoining cut. The application of the horizontal spring is also seen in this illustration.

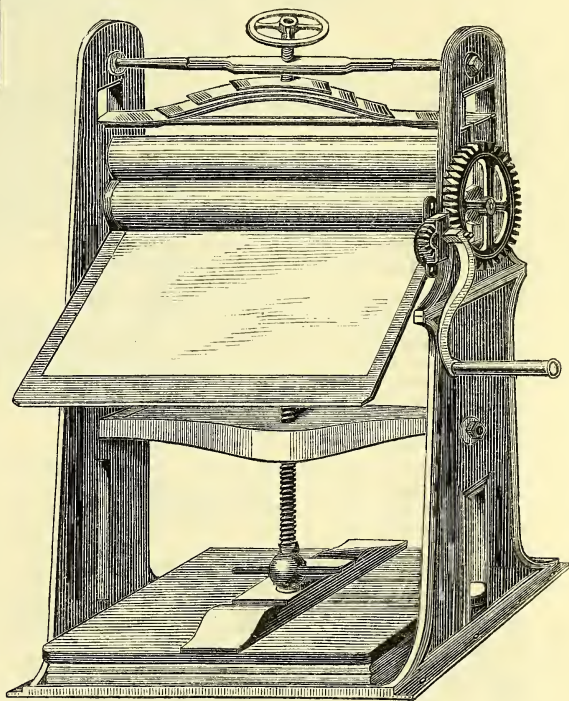

Tindall's Registered Mangle.

Napkin press. Kitchen range.

543 REID, JAMES, 10 Thornton Place, Aberdeen—Designer
and Inventor.

Model of a bathing, washing, wringing, and mangling machine. A self-acting cradle.

544 TARIN, MARC LOUIS ADAM, 8 Nelson Street, Mornington Crescent Camden Town—Designer and
Inventor.

Improved dust-pan, with a reservoir to contain the dust, and a means of quickly discharging it.

Book and barrel-form cartridge pouches for sportsmen; for the protection of a new powder-and-ball cartridge.

Self-descending reflective nozzle, with wire and shade.

Gold embroidered pillar candle lamp, magnifying reflector.

545 STUTTERD, J., Banbury—Inventor and
Manufacturer.

New mangle, with elastic pressure, which may be fixed either to the wall or table. The elastic pressure is obtained by an application of vulcanized caoutchouc above the rollers. It may be used as a table or fixed to a wall, being compact, simple, and efficient. The following cut represents this mangle; see next page.

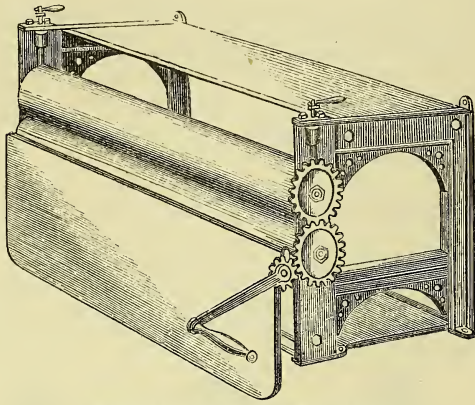

Stutterd's New Elastic Pressure Mangle.

Improved portable mangle, on the same principle. Small model, of varied construction. New roller window-blind.

546 FRYER, RICHARD, 4 Wood Street, Spitalfields—
Inventor and Manufacturer.

A washing, wringing, and mangling machine.

Double-acting washing-machine, by which one person can wash different sorts, or first and second, at the same time. Train of models to illustrate the same.

547 BAKER & Co., 65 Fore Street, Cripplegate—
Inventors and Manufacturers.

A revolving mangle, for pressing and putting a gloss on linen and other woven fabrics, &c. Capable of mangling articles of great length. It is simple in its construction, and can be worked by a boy.

548 MACALPINE, WM., Hammersmith—Inventor.

Patent washing machine for washing linen in hospitals, or cleaning rags for the manufacture of paper.

A patent revolving vessel with steam apparatus for washing heavy goods.

550 TUPPER & CARR, 3 Mansion House Place, City—
Patentees and Manufacturers.

Specimens of corrugated and plain galvanized iron, for roofing purposes. Rain-water pipe, both cast and wrought; guttering, gas and water tubes. Chains, of various sizes. Nails; screws; ships' bolts; wire-rope. Cast iron galvanized garden sofas, chairs, and flower-stands. Various sorts of galvanized wire-netting and fencing; also galvanized wire for telegraph purposes. Galvanized fenders, fire-irons, fire-guards, fire-dogs, &c. Also various descriptions of ornamental cast-iron work galvanized; and specimens of bits, curb chains, stirrups, and buckles. The whole intended to show the innumerable articles to which the process of galvanizing can be applied.

[The process of galvanizing is one comparatively new to this country, it having been introduced under a French patent granted to Mons. Sorel, about eight years ago. The process consists in giving a coating of metallic zinc (which zinc should be of the purest description) to any article in iron, the iron being first chemically prepared, by a very interesting process, for the reception of the zinc. The demand for this very useful manufacture has been but limited till within the last few years; but the attention of the Government has of late been turned to it, and it has been used extensively in all the dock-yards for roofing purposes, and on board all the vessels in the navy for lining the coal-bunkers.]

551 STANLEY, C., 238 High Street, Borough—Inventor.
Model of coal scales for ships, with regulating lever.

552 ORPWOOD, G., 82 Bishopsgate Street—Inventor.
Patent self-acting coffee roaster.

553 KENT, GEORGE, 329 Strand—Inventor, Patentee, and
Manufacturer.

Rotary knife-cleaning machine, in eight sizes, and in section. This machine is represented in fig. 1. by a transverse section, in which the position of the knife and the arrangement of the rubbing surfaces are shown. In fig. 2, a perpendicular section is given, representing the interior of the machine. In fig. 3, a side elevation is shown, with the apertures for the knife.

Fig. 1.

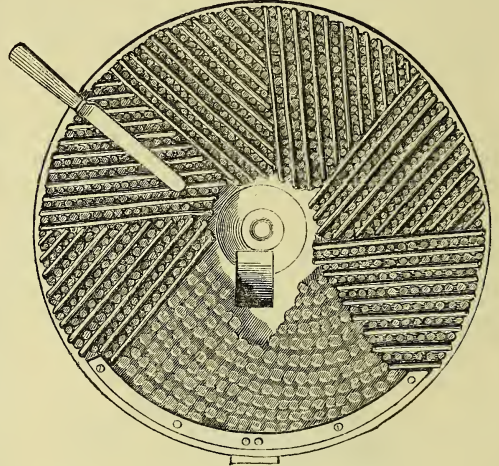
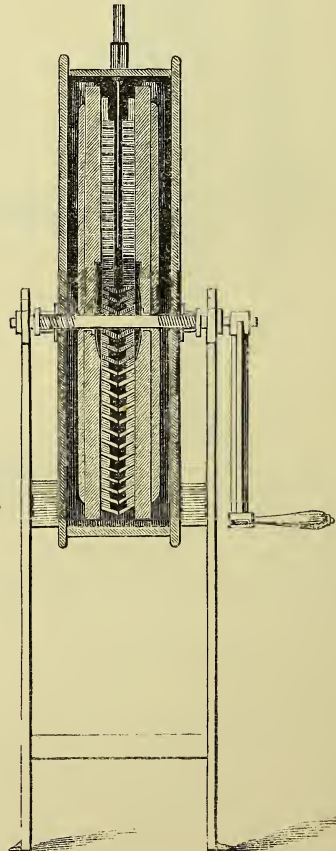
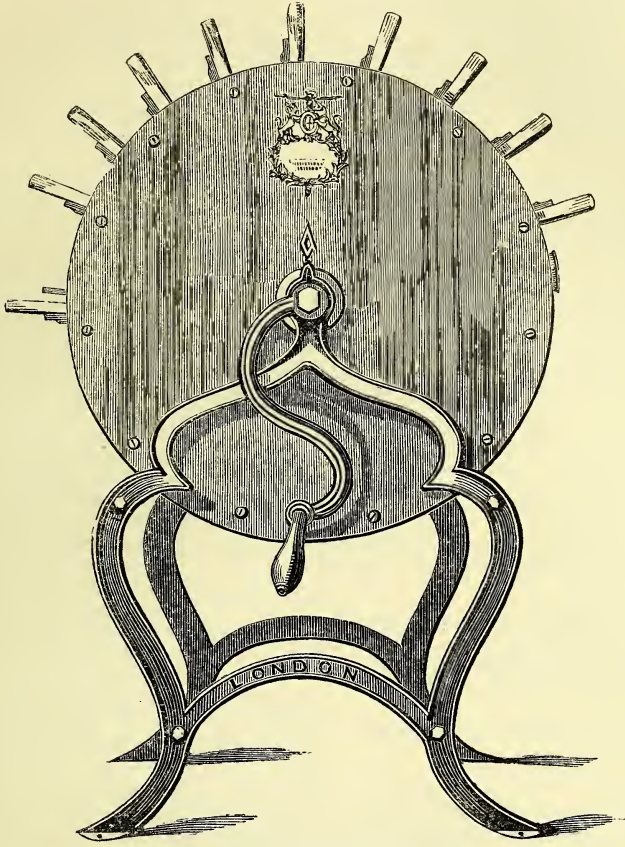

Fig. 2.



Kent's Rotary Knife-cleaning Machine, Fig. 1. Transverse Section.
Fig. 2. Perpendicular Section.

Fig. 3.



Kent's Patent Rotatory Knife-cleaning Machine.

Brushes or buffers of the knife machine. Original American knife-cleaner.

Triturating strainers for domestic or manufacturing purposes. Rotary cinder-sifter, for domestic use. Working model of the same.

554 MORETON, J., *New Vauxhall, Wolverhampton*—
Inventor.

A mangling machine.

555 HARRISON, W., *Fisher Street, Birmingham*—
Manufacturer.

Bright and tinned round and oval short-handle frying-pans. Bright round and tinned oval hanging frying-pans. Bright round long-handle frying-pans. Bright round and oval bake-pans.

Havannah sugar-moulds and large moulds for refining sugar, tinned, painted, and coated with "patent glass enamel."

Tinned small mould, for refining sugar.

Sugar bowls and skimmers, tinned and coated with "patent glass enamel."

556 GIDNEY, JEREMIAH WILLIAM, *East Dereham, Norfolk*—Inventor and Manufacturer.

Models:—an improved six-wire strained fence, with gates for parks, pleasure grounds, and agricultural purposes; a portable iron sheepfold, on wheels; and iron entrance gates. Sundry pieces of ornamental castings, for gates, palisading, &c.

Model of a door, fitted with lever spring-drop, to exclude the draught from below the door, where the step or sill is worn away. Invented and registered by Morris Gardiner, of Ashill, Norfolk. Full-size lever spring-drop, for the same purpose.

Model of hemispherical stove grate, with fire-brick back, designed, registered, and manufactured by Messrs. Barwell and Co., of Northampton. Fender for the same.

Model of a green-house, with economical heating apparatus, registered by J. N. Gibbs, Wendling, Norfolk.

Three sets of ornamental gothic hinges for church doors, designed by S. S. Teulon, Esq., and manufactured by the exhibitor.

557 WATTS & HARTON, *61 Shoe Lane, Holborn*—
Manufacturers.

Specimens of pewter articles, quart and pint drinking cups. Melon-shaped moulds for icing puddings. New pattern ice-cream moulds. Warmer and cooler, of improved construction, for confectioners' counter, to keep soups and pastry warm in winter, and to keep ice creams and iced water cold in summer. Oval meat dish. Hot-water dish. Improved hot-water plate and stand. Collection or communion plate. Hot water, butter, and gravy boat, wicker handle.

Music plate, for printing music. Title-plate, for printing title-pages.

Brass castings—various patterns of animals, busts, figures, &c.

559 BAKER, W., *14 Allen Street, Goswell Street*—
Manufacturer.

Awls, bodkins, steels, and other implements, for shoemakers, carpenters, &c.

560 FARROW, CHARLES, *18 Great Tower Street*—
Manufacturer.

Corking, bottling, bottle-washing, automaton funnel, and other machines used in the management of wines and other liquors.

563 HALE, JAMES, *Walsall*—Manufacturer.

Spring curb hooks for bridle-bits. Steel spring swivels for shot-belts. Powder-flasks and rifle-slings. Spring hooks for dog chains. Pillar chains. Back chains, &c. Fancy dog and parrot chains. Polished steel pole chains for pair-horse carriages. Stirrup-leather buckles, girth buckles, &c. Spring billets for pillar reins, bridles, &c. Plain and spring coskeys for tandem traces. Fancy chain dog collars. Polished steel trace end chains.

565 ROBERTSON, HUGH, *Milngavie, Scotland*—Inventor.

Cutter gauge for cutting a square. Machine for washing yarn. Trap for shooting pigeons. Rat-trap.

566 POPE, WILLIAM, *Bridge Street, Exeter*—Manufacturer.

Felt, finished state; used instead of leather, for pump valves, and for shoeing horses. Same material, but in a different stage of the manufacture; used in polishing marble instead of the lap; and for back collars of carriage wheels, &c.

Furnace for consuming smoke, with apparatus for producing naphtha, if required.

568 M'CLURE, JOHN, *Galloway House, Garlieston, Scotland*—Inventor.

Model of a swing-door, showing four ways of balancing the same, so that it shuts of itself, without the use of springs or pulleys.

570 GREEN, CHARLES, *2 Portland Street, Brighton*—Inventor.

Machine for cutting bread, for domestic use, in uniform slices of different thicknesses. A letter-box.

571 GRAY, JOHN, *Dunbar, Scotland*—Manufacturer.

Pattern of traps for killing rabbits, &c.

572 ENGLISH, J., *Epping, Essex*—Manufacturer.

Entomological fumigating apparatus, designed to drive lepidopterous insects from their natural habitats; and also to facilitate the capture of entomological specimens. The same apparatus is also useful for fumigating plants, and is constructed to turn with a winch, being enclosed in a mahogany case for convenience of pocket carriage.

573 COLLINGE, CHARLES, & Co., *65 Bridge Road, Lambeth*—Designers and Manufacturers.

Working models of patent spherical gate hinges and gate fastenings. The patent spherical hinge consists of a ball revolving in a cup socket, both being case-hardened, and is applicable to all kinds of gates and doors. The improved gate fastening consists of several bolts thrown into staples by the action of one key or lever.

Patent spherical and rising hinges. Doors fitted with the rising hinges, rise as they are opened clear of the carpet or mat on the floor, and close by their weight acting on the spiral screw of the hinge.

574 PINDER, W., & Sons, *Sheffield Works, 85 Travis Street, Manchester*—Manufacturers.

Files.—Specimens of doctors in elastic steel, composition, German nickel, tutang or Chinese copper, and cast-steel pin files, used by calico printers.

Files for machine makers.

[The term "doctor," given to a part of a calico-printing machine, represents a long blade of steel, or of some other metal, which is applied to the engraved surface of the copper print-cylinder, for the purpose of removing its superfluous charge of colour. The adherence of the superfluous colour being a great difficulty on the introduction of the machine, accident led the inventor to apply a knife-edge to the revolving cylinder with a successful result.—R. E.]

575 BRADNACK, I. R., *Great Yarmouth*—Inventor.

Pair of summer skates, adapted for a macadamised road, or any firm, level surface.

Model of a door, with an improved fastening. Improved knocker and letter-plate for a door.

576 BURROWS, THOMAS, *Barnsley*—Inventor.

Bed-joint, intended to supersede the use of screws.

577 HEDLEY, G., *Ireland*—Inventor.

Gas-cooking apparatus.

578 LEARWOOD, THOMAS, *Truro*—Inventor.

Screw-driver, of considerable power.

Portable walking-stick stool, made of lance-wood, to imitate cane. Chair, adapted for ladies' schools, cane-seat, and back birch, in imitation of rosewood. Fancy chair, for drawing-room, birch, with willow seat. Windsor chair, for kitchen use; birch, in imitation of mahogany, and French-polished.

579 COOK, THOMAS, *Ann Street, Plumstead*—Inventor and Manufacturer.

House alarm, to be fixed to doors or windows, to prevent them being opened at night without making a loud report. The same, in gardens or shrubberies.

580 ARMSTRONG, JAMES, jun., *10 Pollen Street, Maddox Street, Regent Street*—Manufacturer.

Dressing and other combs, tortoiseshell and horn cases; metal combs and whisker combs.

581 HUGHES, HESKETH, *72 Charles Street, City Road*—Inventor.

Patent gauffering machine, dispensing with hand labour.

582 HAYWARD BROTHERS, *196 Blackfriars Road*—Inventors and Manufacturers.

Sheringham's registered ventilator; made of iron ja-panned, for the admission of fresh air into a room without draught.

583 LEAVER, JAMES, *Cookham, near Maidenhead*—Designer and Manufacturer.

A corona lucis for lighting a church, the pattern being the leaf and branch of ivy, with the branch made in one piece.

584 HAYNES, JOSEPH, *88 St. James's Street*—Inventor.

Apparatus for extracting corks, by applying a lever and screw of peculiar construction.

587 KNIGHT, T. W., *33 Regent Terrace, Widcomb, Bath*—Inventor.

Bolt for folding-doors, which fastens on closing the right-hand door.

591 BISHOPP, Rev. JOHN, M.A., *11 Canterbury Row, Kennington Road*—Inventor.

Rotary cinder sifter. The cinders are expeditiously sifted, and (without opening the machine) are afterwards made to fall down instantly into the coal scuttle, so that no dust can possibly escape to cause any annoyance.

592 HOCKIN, CHARLES, *38 Duke Street, Manchester Square*—Part Owner and Agent.

Carson's patent meat preserver, consisting of a syringe or force pump without a valve, which injects fluids into animal substances and preserves them from the centre to the surface; a joint is salted in ten minutes instead of fourteen days; meat can be flavoured as salt meat, and still the gelatinous part be retained.

By injecting a few ounces of brine or syrup into the soft part of a joint, it may be kept many days beyond the usual time.

- 594 JENKINSON, JAMES, 21 *President Street, Gosnell Street*—Inventor.
Improved blind roller and spring bracket. The spring is introduced into the bracket instead of the roller, in order to make the apparatus more simple, neat and cheap, and less liable to get out of repair. The roller can be removed from the bracket, and the blind slid into a dove-tail groove. Stove with descending flue.
- 595 MOORE, J., 38 *Clerkenwell Close*—Proprietor.
Patent lever ventilator for any form of window.
- 597 AZULAY, BONDY, *Rotherhithe*—Inventor.
Hot-water bottle bath; with double sides, and between them a non-conducting substance. Gas-stoves.
A washing-copper and trough, heated by gas; the water keeps hot the whole time of washing, and is regulated at pleasure. Flat-irons heated by gas.
Window-roller bracket spring. The roller may be released without cutting the cord. Should the cord break, the roller cannot spring out of bearing.
- 600 WENHAM LAKE ICE COMPANY, 164A *Strand*—Manufacturers.
Ice safe or refrigerator, for keeping wine and provisions cool: lined with the patent glass enamel.
Syphon water filter, capable of instant adaptation to any existing cistern or water-butts, invented by Alfred Bird.
[The solid masses of ice brought to England from America, are obtained from freshwater lakes. The Wenham Lake in the State of Massachusetts, is not far from Renton, and is situated in a hilly district. A complete ice-cutting establishment exists at this lake, and when the ice is a foot thick it is cut by a peculiar plough, drawn by a horse. The blocks are cut with an ice-saw, drawn to the ice-store, and for a time kept there. 15,000 or 20,000 tons of ice can be stored at one time in this repository, whence it is despatched by rail to the market. About 400 tons of ice in a day are frequently carried away. The annual consumption is enormous.—R. E.]
- 601 KEITH, GEORGE, 36 *Piccadilly*—Manufacturer.
Ling's patent mahogany ice-safe, for the preservation of all kinds of provisions, icing wines, water, &c.; the same in deal. Ling's patent metal ice-box for hot climates. Gablen's ice-box. Domestic apparatus for making ice-creams. Wine freezers. Apparatus for making ice-creams by the aid of freezing powder. Ice-maker, for freezing a small quantity of water in tubes with the freezing powder, for medical or other purposes. Registered ice-plane.
Coffee or chestnut roaster.
"Magic mirror," which is said to resist the condensation of the breath on its surface in cold weather.
Liquid meter (in action), for measuring water, spirit, or any kind of liquid, adapted for distilleries, water companies, &c.
- 602 HOLLAND, THOMAS, 40 *South Audley Street*—Inventor.
Improved brass cock for kitchen boiler, giving out hot and cold water, and filling itself.
- 604 HELY, ALFRED AUGUSTUS, 16 *Manchester Buildings, Westminster*—Inventor.
Patent cork-driving apparatus and vent-bottle. The former is applicable to the corking of any description of bottles, but especially to the "vent-bottle," which is simply an ordinary bottle with a small orifice under the rim, through which, on the cork being suddenly compressed into the neck, the quantity of liquid displaced is ejected.
Sliding candle-lamp. A contrivance for preventing candles from guttering, and facilitating the use of a snuffless wick in common tallows.

Chemical vase, showing the application of oil to the disinfection of noxious matter, by confining the effluvia under water, or directing its escape through a tube into the air. Water is poured into a vessel, and a pipe is let down until the water rises about one-third in the pipe. Oil is then poured upon the water to fill the pipe another third. The matter drops through the oil into the water in the tube, where it is freed of any oily particles it may have gathered in its passage through the oil, and finally deposits itself in or upon the water in the body of the vessel.

- 606 BENTLEY, W. H., *Bedford*—Inventor and Manufacturer.
Garden irrigator, for watering plants and flowers.
Cooking apparatus, for boiling and steaming, and general culinary purposes.
Self-acting chimney-pipe, intended to obviate the inconvenience of smoky chimneys.
Self-acting kitchen-range, upon a new principle. Ramoneur apparatus, for sweeping chimneys without the aid of climbing-boys.
Universal tea-kettle, which "will boil two gallons of water in ten minutes."
Alarm lock for the protection of life and property. Registered stove. Improved coffee-pot. Improved filtering cistern.
- 607 DANIELL, J. C., *Limpley Stoke, near Bath*—Inventor.
Piece of ordnance, loaded at the breech instead of the muzzle, it can also be loaded and discharged in less than half the time taken to load ordinary guns, and requires only half the powder to each charge.
- 609 HUGHES & KIMBER, 106 & 107 *Shoe Lane, Fleet Street*—Manufacturers.
Copper-plate for line engraving. This plate has been extended three inches by hammering, and is as hard and highly polished as the material will admit.
Steel plate for mezzotinto engraving, prepared with the finest surface, and of even temper throughout. Thin steel plates, similar to this, were first invented by Richard Hughes, in 1822.
[The intention of extending the surface of a copper-plate by hammering, is to condense its molecular structure, as far as that can be accomplished by mechanical means. In this process, a very large amount of latent caloric is developed—it might be almost said to be forced out.—R. E.]
- 610 MOREWOOD & ROGERS, *Steel Yard Wharf, Upper Thames Street*—Inventors and Proprietors.
Specimens of rain-water gutters and heads, and mouldings for architectural purposes, made of the exhibitors' patent galvanized tinned iron. These mouldings, at a small expense, add to the appearance of a building, are free from liability to rust and discolour, and may be painted to resemble stone.
Patent galvanized tinned-iron pipe, for conveying water or gas; its recommendations are economy, cleanliness, and freedom from the bad consequences that frequently attend the use of lead pipes for conveying water.
Samples of patent galvanized tinned iron wire for electric telegraph, fencing, and other purposes.
Samples of patent galvanized tinned-iron chain of various sizes.
Piece of the exhibitors' patent leaded sheet iron; applicable for making baths, water-cans, gas-meters, and most of the purposes to which tin-plate is applied, is much less expensive than that material, and wears better.
- 611 MITCHELL, JAMES, *Stonehaven, Scotland*—Inventor.
Tin-plate pipe-tops. German silver pipe-tops, and sterling silver pipe-tops, with chain and picker. Malleable iron tobacco pipe, invented by the exhibitor.

612 HAMPDEN, JOHN, 448 *West Strand*—Co-Proprietor and Agent.

New and improved fire escape; also applicable for a scaling ladder, scaffolding, &c.; made entirely of iron.

Williams's temporary rudder, stated to be capable of being shipped at sea in any weather.

Scott's elastic door and gate spring.

Nash's air-tight jar for oil, ink, blacking, &c.

Loysel's tea-urn. A tea-urn and tea-pot are here comprised in one vessel, each distinct in itself. From the same tap may be drawn tea or water, as required. It is heated by an iron heater, spirit lamp, or gas jet.

Improved China and glass letters for shop fronts, &c.

614 DURHAM, T. D., 16 *Linton Street, New North Road, Islington*—Manufacturer.

Registered hot-air funnel kettle for boiling water on a common fire in a few minutes.

615 GRAY, JOHN, 11 *Inverleith Row, Edinburgh*—Inventor.

Registered gravy dish for separating the liquid fat of roasted or boiled meat from the gravy at table.

616 HANSON, JOHN, *Huddersfield*—Inventor, Patentee, and Manufacturer.

Samples of patent manufactured lead.

620 SEARS, ROBERT, 2 *York Street, Middlesex Hospital*—Designer and Manufacturer.

A block tin-plate coffee filterer, with spirit lamp to boil water on the table; it may be used with or without the lamp.

Small cooking apparatus, for chops, steaks, or cheese, with spirit lamp designed to produce a powerful heat.

Tea-kettle to boil water on the table.

621 RIDLEY & EDSER, *Vincent Square, Westminster, and St. James's Terrace, Vauxhall Bridge Road*—Inventors.

Working model, one quarter of the full size, showing a part of the interior of a house with staircase, having patent safety doors and apparatus attached, by means of which persons cannot enter or leave the house without giving immediate alarm; the apparatus also indicates that part of the house which the persons entered or left. It is applicable to iron chests, bankers' rooms, warehouses, &c., and can be adapted to existing buildings at a moderate cost.

622 TAYLOR, JOSEPH, *Wolverhampton*—Inventor and Manufacturer.

Bramah locks, with guards. Improved balance detector lever locks. Barron's chest and latch till-lock. Full-warded chest and tumbler-locks, &c.

626 CUNNINGHAM, ALBERT ROBERT, *Addison Road, Kensington*—Inventor.

Registered knife-cleaner and sharpener. The leathers are fixed on this board in diagonal lines with intermediate spaces, to secure a constant and equal distribution of emery, and a great amount of friction on the blade of the knife. A steel is fixed diagonally for the purpose of sharpening when required.

627 FARRAR, WILLIAM, *Leicester*—Inventor and Manufacturer.

Zinc fountain, with figure, made by hand, without the aid of casting or stamping.

Improvement for sash windows, to work without lines, pulleys, or weights.

Cylindrical bed-warmer, which can also be used for airing linen, &c.

628 SHAVE, W. J., 74 *Watling Street*—Manufacturer.

Patent oven, having the heating apparatus within; adapted to domestic, chemical, and shipping purposes; the same, with hot or drying closet.

630 COMMON, JOHN, *Melrose, Scotland*—Manufacturer.

Slide ball-cock, capable of standing a great pressure of water. Invented by the exhibitor.

633 BURNEY & BELLAMY, *Mill Wall, Poplar*—Designers and Manufacturers.

Tanks for water, biscuits, oil, and paint.

Cistern for house supply, or for holding oil, tar, or spirit.

Barrel for oil, tar, or spirit, with cock; air and water tight.

634 MASTERS, THOMAS, 309 *Regent Street*—Inventor and Manufacturer.

Aërating and soda-water machines. Freezing machines, and preserving and cooling apparatus. Rotary knife-cleaning machines.

The annexed engravings represent the aërating and freezing machines, and also the rotary knife-cleaning machine.

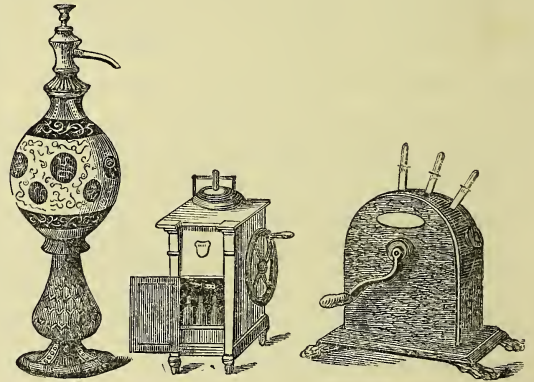

Aërating.

Freezer.

Knife-cleaner.

Freezing jugs and cooling decanters, percolators, wine-coolers, butter-coolers, &c.; new forms of anti-corrosive self-acting taps, cooling and heating apparatus, &c.

636 HART & SONS, 53, 54, & 55 *Wych Street, Strand*—Manufacturers.

Improved door-knobs and finger-plates in brass, china, glass, and fancy woods; the knobs mounted with Pitt's patent self-adjusting spindles.

Dr. Arnott's ventilating chimney valves; improved. Ironmongery for cottages.

[The ventilating valve of Dr. Arnott is a very simple apparatus. It consists essentially merely of a balanced flap protecting an aperture into the shaft of a chimney. The rapid ascent of the heated current of air up the chimney, draws a constant supply of air from the room, at that part of an apartment, near the ceiling, where heated and vitiated air is most abundantly present. The valve is adjusted by its balance, so that the entrance of smoke is prevented by its closure.—R. E.]

637 RIDDLE, WILLIAM, *East Temple Chambers*—Inventor.

1. Self-supplying pencil cases. The reserve is at the point, and each lead supplies itself by merely turning back the wire in the usual manner.

2. Ever-pointed pencils in cedar and ivory. One object has been to construct a cedar pencil that does not require cutting.

3. Reservoir gold pens, containing a large supply of ink.

4. Inkstands, extending pencil-cases, and penholders.

5. Folio clips, for holding papers. 6. The self-igniting gas burner. 7. The porte facon, or wine handle.

8. The latch and bolt union, combining the advantages of each in one contrivance. 9. Hat pegs.

10. A marine hand signal lamp, to be used in fogs and emergencies at sea. It may be instantaneously lighted.



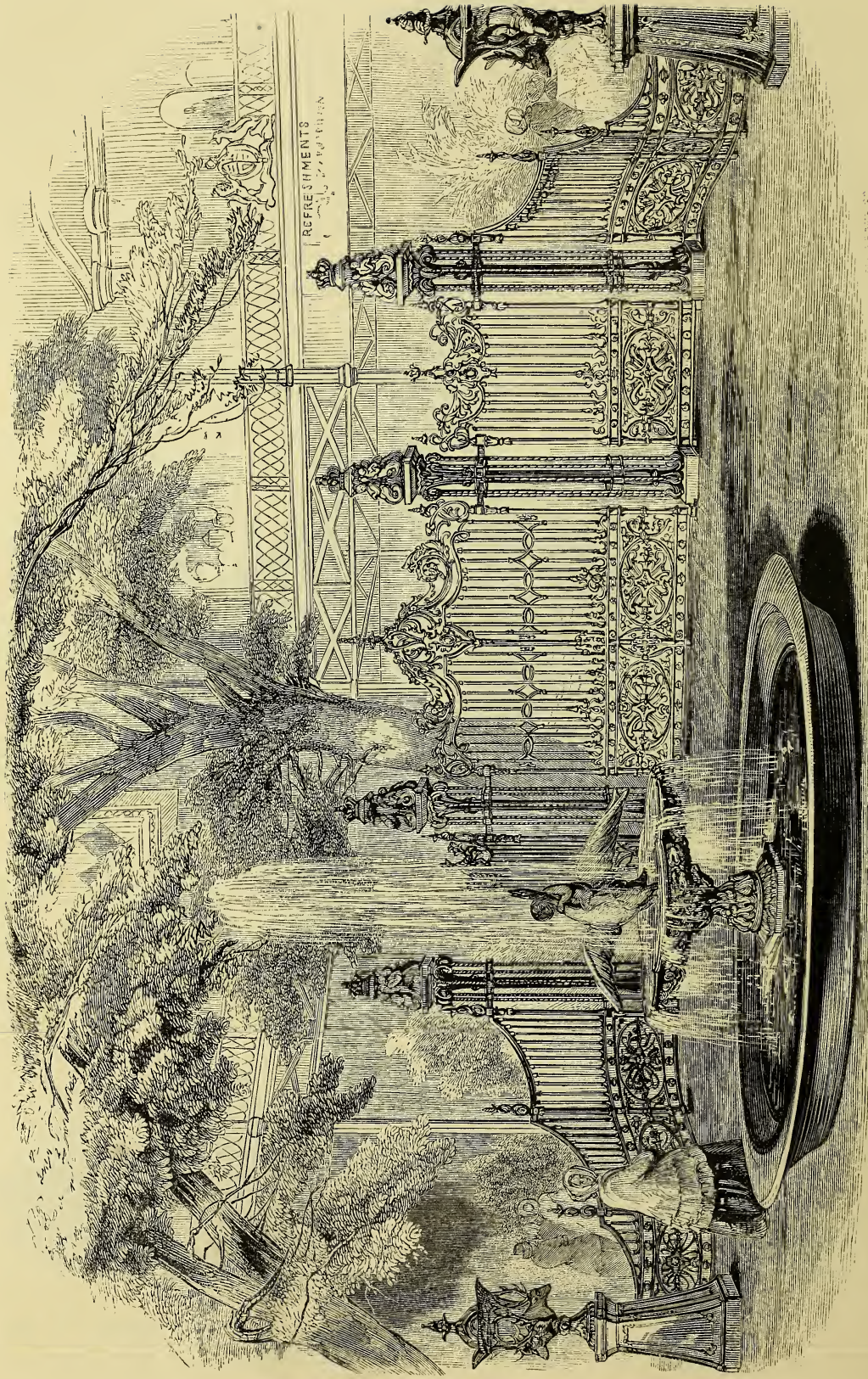

FOUNTAIN AND PARK GATES IN CAST IRON. COALBROOKDALE COMPANY.

11. Decanters, with self-acting stoppers, and other improvements.

12. A "rose" shower-bath, with a flexible tube, intended to be attached to the house cistern.

13. Model of part of a vacuum shower-bath, which is fitted by creating an instantaneous vacuum.

14. Metal jugs, with improved lids.

15. A jar, the cover of which dipping into mercury will be air-tight. The novelty consists in the mercury not spilling, even if the jar be turned upside down.

16. A looking-glass, with rotary base.

17. Model, illustrative of a railway carriage, lighted by an improved system of applying compressed coal gas.

18. Plan or model, illustrative of a new system of cocks and pipes, for extinguishing fires in steam ships, by means of the steam from their boilers.

19. A sea or boating hat, with self-inflating lining, useful in case of accidents on the water.

20. A milk-can for railway conveyance.

21. Corkscrews, with wire nippers.

22. A suspensory couch, for removing wounded men and invalids from their beds with ease: it is intended for hospital purposes.

23. Label dampers. 24. Improved foot-bath.

25. The "inverted" reading easel, which holds a book downwards to the eyes of a reclining person, and admits of the leaves being readily turned over.

26. Apparatus for heating curling or other irons by gas.

27. Flat-irons, with detachable handles, intended to be always cool. One handle will fit any number of irons.

28. Convex circular lens lamp shade, of novel effect, and concentrating a band of light.

29. Portable gas and air furnace, exhibited for cheapness.

30. Model of a railway accident buffer, consisting of a large helical spring coil on wheels, exhibited for simplicity and presumed powers of elastic resistance.

31. Detector bolt for cupboard double doors, which must be fastened before the cupboard can be locked.

32. Gutta percha hinges.

33. Chemists' "inverted" bottle, air-tight. The stopper need not to be held in the hand.

34. Door knobs of ornamental glass; of new invention.

35. Model of a zinc chimney, covered with a felt non-conductor, to preserve a hot ascending current, and thus cure smoky chimneys.

36. Scouring paper made from pounded kiln-burnt coke, which has been recently discovered to possess properties adapted for this purpose.

37. Specimens of jet and opal glass, suggested as adapted for pianoforte keys.

38. Mining safety lamp, glazed with talc, and suitably guarded from flying splinters of coal.

In the preceding list, Nos. 1, 2, 3, 10, 13, 17, and 28, are articles for which patents have been taken; and Nos. 4, 5, 6, 7, 9, 11, 12, 14, 16, 20, 21, 22, 23, 24, 25, 26, 29, 30, 31, 32, and 33, are articles which have been registered.

638 NAYLOR, J., 121 Radnor Street, Hulme—Inventor.

Lamps for pillars resting on the ground; and for brackets affixed to the wall.

639 MACHELL, THOMAS, 2 Carlisle Street, Soho—Inventor.

Patent "Barrington lamp." Patent portable shower-bath, adapted for travelling carriages.

640 NIXEY, W. G., 22 Moor Street, Soho—Inventor.

Patent till, or cash-receptacle, for the prevention of fraud, &c. Each sum of money paid is kept separate in its progress to the common till.

Fire-escape, convertible into a moveable seat or an iron deed-case.

Flexible cement. Immersed in water at 120 degrees Fahrenheit it becomes adhesive and ductile, and hardens to the consistency of gutta percha when cold; may be

made of any colour; and to fasten metal, marble, glass, earthenware goods, &c., to wood, or to each other.

641 THE COALBROOK DALE COMPANY, *Coalbrook Dale*—Inventors, Designers, and Manufacturers.

Iron and bronze castings from the Coalbrook Dale Foundry, Shropshire, the materials of the former (specimens of which, in their various stages, are exhibited in the department of "Raw Materials") being produced and supplied by the neighbouring works of Horsehay, also belonging to the Coalbrook Dale Company.

[Shropshire is rich in ironstone, limestone, and coal, the three great requisites for the production of iron for commerce, and the site of the Dale was first chosen for the erection of an iron foundry, from the facilities for water power afforded by the rapid descent of its brook into the Severn. Water power has since, however, been almost entirely superseded in the works by steam. The first single foundry in the Dale was commenced 200 years ago, and has been in the family of the present proprietors nearly 150 years, during which time it has been steadily increasing; and the picturesque and once sequestered valley is now busy with the life and labour of 500 men and their families, the foundries and workshops of the Company filling the larger portion of the bottom of the Dale, while the slopes of the hills are occupied by coppice and fields, and by the houses and gardens of the workmen employed.]

The total number of men and boys in the employment of the Coalbrook Dale Company, at the Foundry and at Horsehay, is between 3,000 and 4,000.]

The following articles have all been invented, designed, executed, and wholly finished at these works (except where otherwise expressed):—

General Ornamental Manufacture.

Ornamental park entrance of cast-iron, bronzed; consisting of a pair of principal gates, and two side gates, hung on iron pillars of new construction, combining lightness and strength, having finials, emblematic of Peace, supporting an insular crown; also on either side an ogee fence, terminating in stag's-head vases, suggestive of a park. In all comprising a frontage of 60 feet. Each of the four gates was cast in one piece. English design: C. Crookes.

These park gates are represented in the accompanying plate 108.

Ornamental rustic dome of cast-iron, bronzed, 20 feet in diameter by 30 feet high, supported by six double pillars, with finials of guarding falcons, and surmounted by an ornamental weather-rod, and a vane formed by a statuette of "Æolus," modelled by John Bell; the summit of the vane is 46 feet above the flooring of the dome. The structure is adapted for glazing, as a green-house, a summer-house, a covered garden, orchestra, or receptacle for a public statue in metal or marble. It contains an iron casting of the "Eagle-slayer," 11 feet 6 inches high, including the pedestal. The eagle, transfixed by the arrow of the archer, forms the centre ornament of the roof of the dome. English design: C. Crookes and J. Bell.

This dome with the "Eagle-slayer," is represented in the accompanying plate 112.

Ornamental fountain of cast-iron, bronzed, seven feet wide, by eight feet high, with group of "Cupid and the Swan." The group forms the jet, and occupies the centre of a *tazza*, ornamented with a decoration of the white and yellow water-lily. English design: John Bell.

Ornamental chimney-piece and grate, with decorations illustrative of deer-stalking, boar-hunting, and hawking. The figures are of cast-iron, electro-gilt, and the mouldings are marbled. The grate consists of burnished steel front, and ornaments in bronze, electro-gilt. The decoration connects, in one design, the fender, ash-pan,

and grate. The fire-brick for the back is in one piece, including the bottom of the grate, on which the fire rests. The fender, ash-pan, and grate remove in one piece, to afford greater convenience in cleaning the chimney. The ends of the mantel-piece are decorated with bronze electro-gilt and glass vases; the centre is enriched with a bronze group of the "Death of the Stag." Modelled by B. W. Hawkins, designer.

Bright ornamental grate, composed of burnished and sprung steel front, with electro-gilt ornaments, novel panels and mouldings, and a marble mantel-piece. English design: Charles Crookes.

Black cottage register-grate of very simple construction.

Kitchen-range, consisting of an oven, with hot closet, both of wrought plate-iron, with dampers of novel construction, by which the flues are easily cleaned; a large grate for fire, with portable bars; a strong back boiler of wrought iron, with suitable water and steam taps; iron chimney-piece with side and back plates complete; the whole with steamer attached.

An economical close fire-range or cooking stove, complete, with large wrought plate-iron oven, and portable bars. The grate is lined with strong fire-bricks, and fitted with boiler, steamer, and fish-kettle.

Back boiler-range, of new pattern.

Economical cottage-range.

Ornamental cast-iron fire-dog, or andiron, from an Italian design.

Ornamental fenders, in steel, bronze, and or-molu, complete with fire-irons.

Ornamental vase and base, adapted for a garden, fountain, or other ornament; of foreign and English design. This vase is represented in the adjoining plate 47.

Ornamental cast-iron bronzed flower-pot stands, of English and foreign designs.

One of these stands is given in the annexed illustration. Serpent-handled vase and base for earthen pot, with flowers; classic design. This vase is represented in the following illustration.

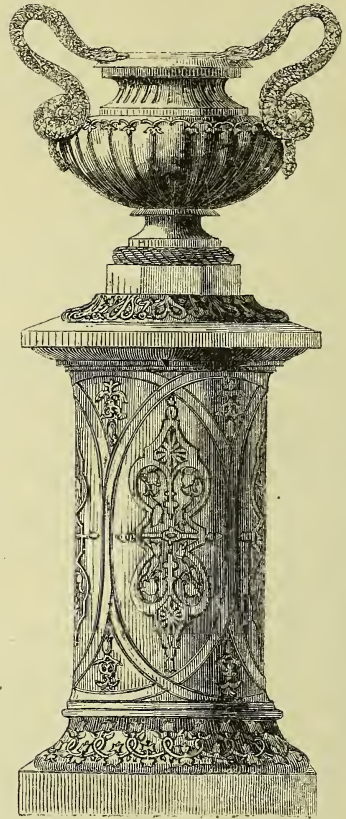

Coalbrook Dale Company's Serpent-handled Vase.

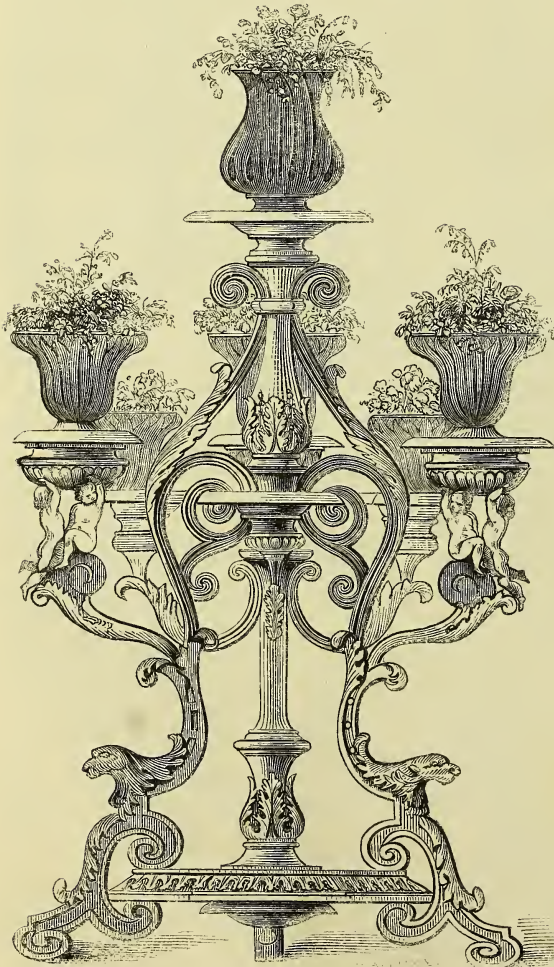

Coalbrook Dale Company's Bronzed Flower Pot Stand.

Single deer's-head vase and base, for earthen pot. English design.

Intricate iron casting, painted in white and gold, of an Elizabethan looking-glass frame, with branches. English and foreign design.

Intricate iron casting, bronzed and marbled, of a hall-table, arranged with pedestals for hats, coats, and umbrellas, containing also a pillar for a lamp and looking-glass, with boxes for letters and for brushes, and an inkstand. English design.

Garden-chairs, of rustic ornament, in cast-iron bronzed.

Hall-chairs of wrought and cast-iron.

Cast-iron chess-tables.

Ornamental stands for umbrellas, in cast iron, bronzed, with loose pans, marbled.

Hat, coat, and umbrella-stands, in cast-iron, bronzed, with loose pans, marbled.

Hall, or console-table, in cast-iron, painted in white and gold, marble top. The same bronzed.

Large table, with cast-iron legs, painted oak; of classic design.

Ornamental ventilators, on Dr. Arnott's principle.

Cast-iron door-scrappers.

Ornamental gas-brackets, of cast-iron, bronzed.

Door-knockers and porters, of cast-iron, bronzed.

Flower-stands, white and gold, with china bowls.

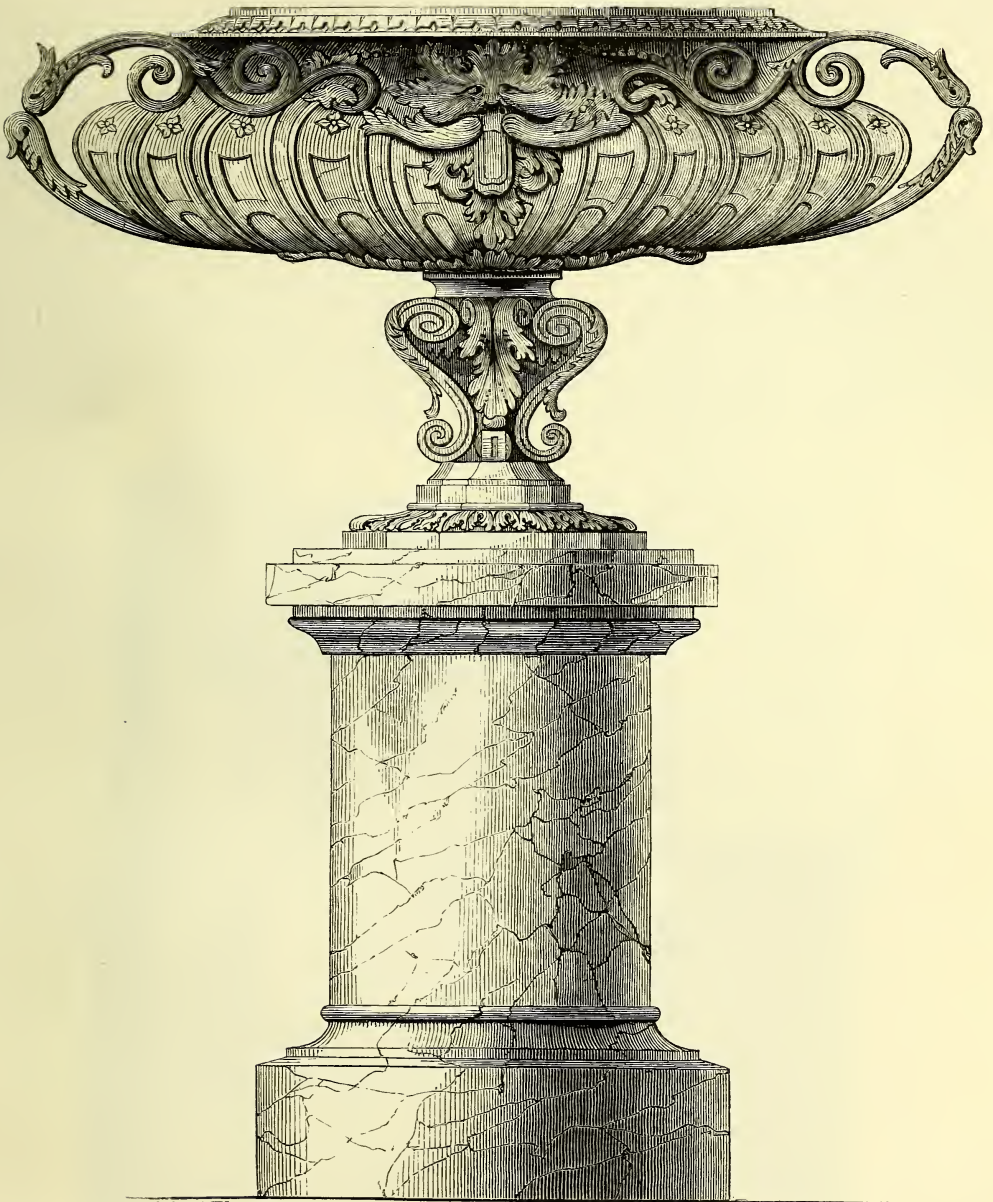

PH. DE LA MOTTE

15. P. 34

Iron casting, rough-dressed from the mould, being a *relievo* of a rustic group.

Various small Works, of Foreign Design, cast in Iron:—

A pincushion. Small jug. Monk and pedestal. Pair of pedlars (man and wife). Setter dog. Pointer dog. Group of wild horses. Lion and boar. Bear, with lamp. Small copy of the Florence boar. Knight, in armour, on horseback. The bear dentist. Group of a knight and a Saracen. Group from the battle of Aboukir. Stag browsing. Boar's-head and deer's-head brackets. Bear and bag-pipes. Bear and young. Pair of goats. Group of an Amazon and a tiger. Gilt vase. Inkstands. Fruit or card-plates. Card-dishes, on pedestals. Pastile-burner. Pair of dancers. Female figure, with fish. Statuette of "Hannibal." Pair of candlesticks. Startled stag. Pointer and hare. Setter dog, "Setting." Setter dog (life size). Greyhound (life-size). A copy of the Warwick vase. A pair of goats at play. A sheep and lamb. A pair of greyhounds at play. A Barbary horse. A pair of small deer. A boy and swan (paper weight). A clock with goat.

Statuettes and Groups of English Design:—"The Battle," a group of stags; and "The Victory," a group of stags, both designed and modelled by B. W. Hawkins. Statuettes:—"The Eagle-slayer," "David slinging," and "Cupid Indignant," all designed by John Bell. A sta-

tuette of Sir Robert Peel. Henry Ross. A statuette of Thalia, from the one in the British Museum.

Works, life size, in bronze:—"The Eagle-slayer," cast in fine bronze and chased, by the Coalbrook Dale Company, from the design and model by John Bell.

"The arrow of the archer avenges the death of the lamb." For the duplicate in iron, arranged architecturally, see the iron dome of the Coalbrook Dale Company.

"Andromeda," exposed to the sea monster. The pedestal is illustrative of the story; in this, as in the other details, the object was to unite in one design, a statue and ornament. The decoration terminates upwards in a pierced comb, in which lurks a diminutive Cupid, launching a dart at Perseus. Cast in fine bronze, seven feet three inches high, and chased, by the exhibitors, from the design and model by John Bell.

642 MILNER & SON, *Liverpool, Manchester, and 47A Moorgate St.*—Patentees and Manufacturers.

Group of patent holdfast and fire-resisting safes, of the first class, with outsides of half-inch wrought-iron, lined throughout, with the exhibitors' non-conducting and evaporating fire-resisting chambers. Exhibited in successive stages of manufacture, to show the internal arrangement. The safe is made from 5 cwt. to 3 tons each in weight.

These safes, of different sizes, and applicable to different uses, are shown in the annexed illustration.

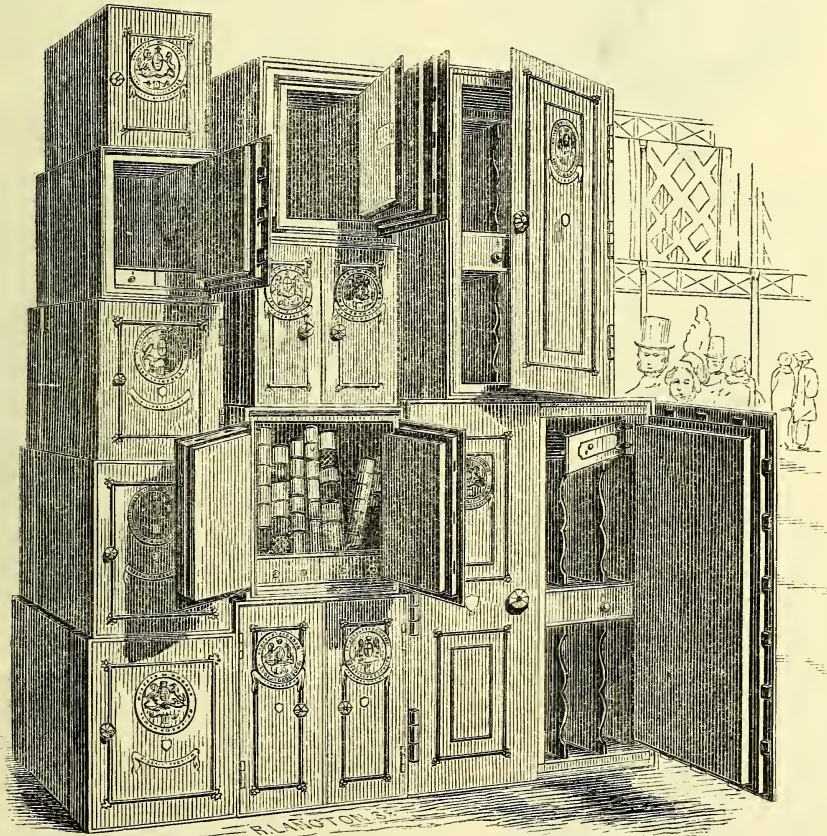

Milner & Son's Patent Holdfast and Fire-resisting Safes.

643 HULETT, DAVID, 55 *High Holborn*—Manufacturer.

Cut chandeliers, for various lights. Etruscan gas-lamp. An ornamental Gothic lantern with stained glass panels; this is shown in the cut on the next page.

Rutter's ventilating gas chandelier. Gas meter, with apparatus attached.

Large bronze candelabrum, copied from the antique. This candelabrum is also represented in the next page.

Five-light ornamental stand for gas.

Glass and china stands, mounted. Platow's patent automaton coffee urn, designed and executed in silver by Barnard & Son.

Steam generator, applicable for cooking, heating water, &c., by gas. Dr. Arnott's self-acting ventilator.

Gas cooking stove and kettle. Bachelor's cooking apparatus.

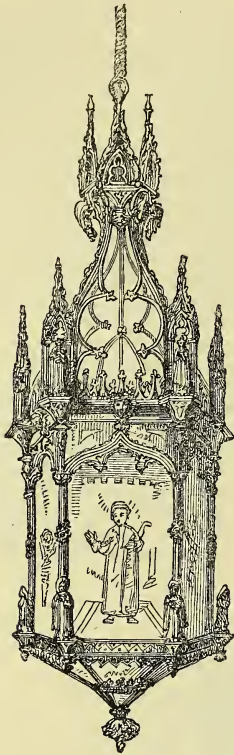

Hulett's Ornamental Gothic Lantern.

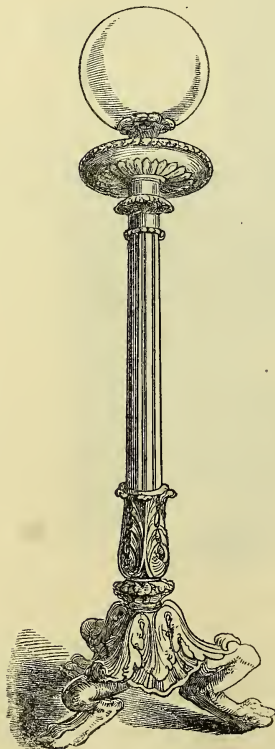

Hulett's Antique Bronze Candelabrum.

644 SEDGWICK & TAYLOR, 186 *Piccadilly*—Designers
and Manufacturers.

Glass lustre, with drop work and various coloured glass flowers, after the old Venetian style.

Ornamented metal chandelier, with looking-glass centre, in panels, chased.

Registered ornamental chandelier, for gas, with griffin branches, springing from blue enamelled globe, with imitation candles.

Registered chandelier, with same design, for wax candles.

Pair of wall lights, after the old Venetian style, with coloured glass flowers, &c., for wax candles.

Crystal glass lustre for gas.

Table lamps on Herculean pedestals.

The patent diaphanous reflector, with table lamp.

Registered chased candelabra. Tripod metal stand. Various patterns of table glass.

Lantern, with reflectors for lighting the outside of houses.

[A Venetian historian of the 13th century says, that the Government cherished the making of glass as the apple of its eye. A Venetian carrying its secrets to foreign countries was punished by the imprisonment of his relatives, and if possible assassinated. Noble families, without loss of caste might marry the daughters of master glaziers of Murano. Glass beads and emblems of shoes formed a large article of traffic with the East; the manufacture is now in decay at Venice, though beads are still made.—R. E.]

645 MILLER & SONS, 179 *Piccadilly*, and 370 *Oxford Street*
—Inventors, Manufacturers, and Proprietors.

Patent Admiralty regulation lights: bright light at the foremast head, green light on the starboard side, red light on the port side, to be used when under weigh. The form of these lights may be seen by the annexed cuts.

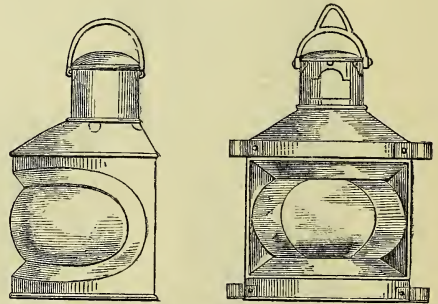

Miller & Sons' Patent Admiralty Regulation Lights.

A common bright light, to be used by all vessels at anchor. Model of a steam-vessel, showing how these lights are placed. The cut on the opposite page represents a steamer with the regulation lights. It shows the proper position for these lights, in order to obviate the confusion likely to arise from the curving of the rays of light over the bows of the vessel.

The following are the Admiralty Regulations which have been adopted since 1840 by all maritime nations:—

A bright light at the foremast head, green light on the starboard side, red light on the port side—to be used when under weigh. A common bright light, to be used by all vessels at anchor. The green and red lights are so placed at the side of the vessel that the rays of the lamps cannot cross the bows. In this manner it is easy to ascertain the position and the course of the vessel, and to avoid collision with her, since the coloured lights give the most certain indication as to whether she is in the starboard or larboard tack.

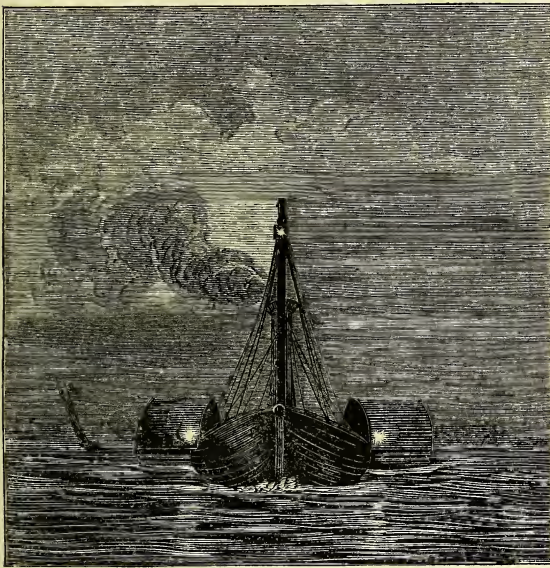

Steamer with Miller & Sons' Regulation Lights.

The following statement has been published by Capt. Denham, F.R.S., which shows statistically the importance of these regulations.

Consequences of collision at sea to British steamers and sailing-vessels, 1845 to 1849.

	SUNK.	DAMAGED.			TOTAL.
		Seriously.	Considerably.	Slightly.	
Steam Vessels	9	9	18	190	226
Sailing Vessels	270	180	668	1,720	2,338

Showing a total of 3,064 cases involving more or less life and property at sea, apart from losses through bad navigation and stress of weather, but chiefly attributable to want of lights and look-out.

Hand, cabin, and deck lamps, various. Carriage-roof lamp, with an improved reflector; and a tricolour hand lamp. Railway, tail, and side lamps. Engine and buffer lamps. Wheel, searchers', and watergauge lamps. Station platform lamps (registered). Double semaphore lamp, a substitute for two lamps.

Table, bracket, and back lamps. Reading lamps. Gig and dash-iron lamps. Hand and night lamps and lanterns. Police, pocket, and reflecting lanterns, for reading at night, and other purposes. Improved stable lamps, for suspending from the ceiling or wall. Wax illuminators. All of a peculiar construction, having short separate wicks, instead of ordinary cottons.

646 CHUBB & SON, 57 St. Paul's Churchyard—Inventors, Patentees, and Manufacturers.

Specimens of the exhibitors' patent detector locks and latches, for various purposes. The cut represents the interior of one of these locks and key.

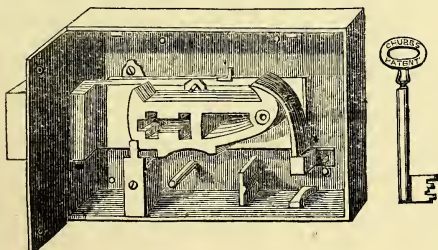

Chubb's Patent Detector Lock and Key.

Specimens of Norman, Gothic, and Elizabethan locks, and ornamental steel keys of various styles and patterns. The Gothic lock and key are shown in the annexed cut.

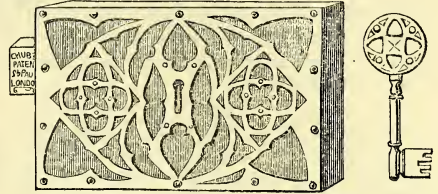

Chubb's Gothic Lock and Key.

Patent quadruple and rim locks.

Patent fire-proof safes, for bankers' use, and model of a patent well safe. The cut shows the form and interior of the fireproof safe.

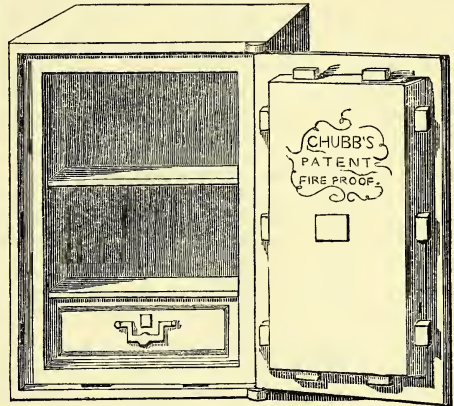

Chubb's Patent Fireproof Safe.

The case containing the Koh-i-noor diamond. This case, which is represented in the adjoining engraving, contains an arrangement for elevating and depressing the diamond without unlocking. It is considered to be impossible to pick the lock or obtain an entrance into this receptacle.

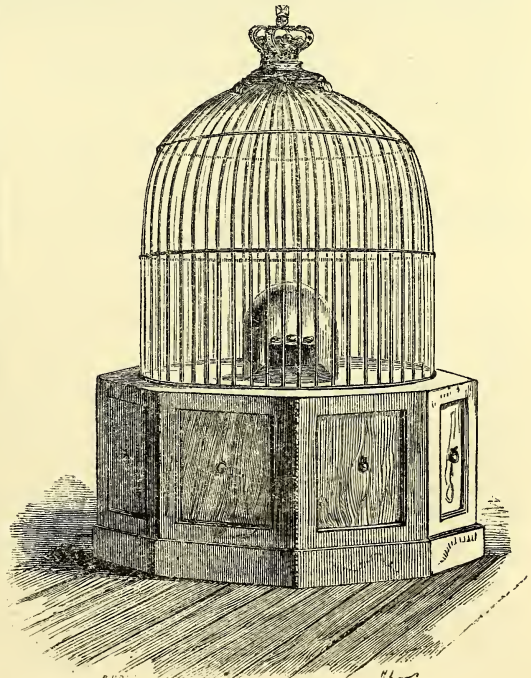

Chubb's "Koh-i-noor" Diamond Case.

[The locks on this principle, for ordinary purposes, have each six separate and distinct moveable tumblers and a detector. If a surreptitious attempt be made to open any one, immediate notice is given by the detector on the next application of the proper key. The fire-proof safes are made of strong wrought iron, lined with hard steel plates, and the chambers all round are filled with non-conductors of heat.]

647 HAYWOOD, J., & SON, 20 *St. James's Walk*, and *Suffolk Street, Clerkenwell*—Manufacturers.

Locks used by cabinet-makers, builders, &c.; specimens of gilding and engraving applicable to every description of fancy brass foundry.

648 MAYO & BATES, *Wolverhampton*—Manufacturers.
Door-lock keys in different stages of manufacture.

[Several manufacturers are exclusively occupied in making keys, in their rough state. The majority are produced by swages or points; superior qualities are from time to time cast of malleable iron and annealed. They are purchased by the lock-makers, and cut to suit the several wards in the locks which they are intended for.—W. C. A.]

649 THE PATENT POINTED SCREW COMPANY,
Wolverhampton—Manufacturers.

Patent-pointed screws, cast out of malleable iron, which can be driven into wood, without boring holes.

[The peculiarity of these screws is in their mode of production. Other screws are formed from iron wire, the head being forced up, and the screw cut in a lathe in use for the purpose; these are cast in sand, and are singular, from their being so, and from the comparative sharpness in the threads, though they are somewhat inferior to those cut by ordinary method.—W. C. A.]

649A HUFFER, JOHN, 20 *Wilderness Row, Clerkenwell*—
Inventor and Manufacturer.

Detector chest lock; a false key is retained in the lock till the proper key is brought to relieve it.

Chest lock with secret action. Spring latch, padlock, locks for chests, desks, trunks, portfolios, drawers, and carpet bags.

650 BIGFORD, H., *Wolverhampton*—Inventor and
Manufacturer.
Improved detector-lock.

650A FOSTER, RICHARD, 1 *York Place, St. George's East*—Inventor.

Self-acting detector lock, applicable to safes, doors, &c. A person attempting to open this lock by a false key, cannot withdraw the key without injury.

651 GOLLOP, JOHN, *Wellington Foundry, Charles Street, City Road*—Manufacturer.

Patent rising and non-rising spring, swing and other hinges for doors or gates.

652 GERISH, FRANCIS WILLIAM, *East Road, City Road*—
Inventor and Manufacturer.

A safety lock, of which it is believed that the key cannot be copied.

A lock of simple and cheap construction.

A simple and cheap hinge, with spring, to close a door one or both ways.

653 BRAMAH & Co., 124 *Piccadilly*—Inventors and
Manufacturers.

Brass case box of wards, showing the security of the locks, invented by the exhibitors.

Brass case-lock, exhibiting the number of changes these locks will admit of. The changes are computed at four

hundred and seventy-nine millions one thousand six hundred.

Copper box of wards, on steel plate, for iron door.

Four-bolt brass case chest lock. Large brass padlock. Iron case two-sided door lock.

Brass case book, drawer, spring-box, and portfolio locks.

Brass barrel padlock. Prison-door lock. Two-sided street-door lock. Large iron padlock.

Brass case desk, cupboard, and chest locks. Three-bolt portfolio lock. Brass case padlocks. Link plate cupboard lock.

Narrow drawer lock. Brass case closet lock. Thin spring box lock.

Box, cut cupboard, book, and portmanteau locks.

Very fine ornamental iron casting.

654 GIBBONS, JAMES, jun., *Wolverhampton*—
Manufacturer.

Improved locks, for doors, drawers, park-gates, &c., in various styles.

655 CARPENTER & TILDESLEY, *Willenhall, near Wolverhampton*—Manufacturers.

Carpenter and Co.'s, Sanders', Tildesley's, and Baillies' patent locks. Rock's patent Gothic case locks. Curry-combs, various patterns. Elastic horse-scrappers.

[The most ancient locks are those which have been in use in Egypt for upwards of 4,000 years, the similarity of which with those of the Faroe Islands is singular. The most ancient lock was a peg lock; its outline may be seen figured among the hieroglyphic representations on Egyptian tombs and temples.—W. C. A.]

Registered, and other latches. Norfolk thumb mortise. New designs in iron and brass padlocks. Door-bolts. Mortice sash locks and latches.

[Wolverhampton is the grand centre for the manufacture of locks, which gives employment to the vast population thickly congregated in the small towns of Bilston, Bloxwich, Willenhall, Melsall, and other hamlets scattered around; in addition to this, it supports no small number of persons, known as middle-men, and factors, who buy and stock the locks of all kinds brought to them by the smaller makers.—W. C. A.]

656 WHITLEY, JOHN, *Ashton, near Warrington*—
Manufacturer.

Case of wrought-iron hinges, of various descriptions.

657 CLARK & Co., *Shakespeare Foundry, Wolverhampton*—
Patentees and Manufacturers.

Patent enamelled ware sauce-pans, stew-pans, pots, kettles, frying-pans, gridirons, digesters, hand-basins, bowls, bread-pans, furnace-boilers, spittoons, stable-buckets, watercloset-pans, &c.

Tables, with enamelled tops, imitation of marble, and tinned; patent cast-iron hinges, coffee-mill, and crimping-machine.

658 OSMOND, GEORGE, 19 *Somers Place East, New Road, St. Pancras*—Inventor.

Improved fittings for roller-blinds, maps, &c. Lock or spring latch, with bit inside the pipe of key instead of outside. Door-bolt, extremely difficult to unfasten by those unacquainted with its action. Self-acting bolts, for double doors, made so as not to admit of locking one door without bolting the other. Sash-fastener, similar to a barrel-bolt, and having a spring, which, when in use, prevents the sashes making a noise.

Patent centres for swing looking-glasses, a substitute for knobs on the outside of the standard; they are made in two parts, one of which is fixed on the edge of the glass frame, and the other on the standard, so that when the glass is put into its place between the standards, and a small lever pressed down, it is securely fixed between

the standards; the centres will sustain the glass in any position. Manufactured at Birmingham by Messrs. Charlton Brothers.

659 **PARKES, HENRY WILLIAM, 110 Strand—**
Manufacturer.

Large brass padlock with 18 guards, on a new principle.

660 **HARLEY, G., Warwick Street, Wolverhampton—**
Manufacturer.

Patent detector locks, for trunks, ledgers, drawers, carpet bags, &c.

661 **CARTWRIGHT, DANIEL, Leek—Proprietor.**

Alarm lock; on an attempt being made to pick it, a bell rings, and when the bolt is shot a pistol is fired. By moving the key in a certain direction it will not pass, and the lock cannot be injured by turning the key the wrong way.

663 **AUBIN, C., Wolverhampton—Inventor and**
Manufacturer.

Specimens to illustrate the rise and progress of the art of making locks, containing forty-four different movements by the most celebrated inventors in the lock trade.

Sections of locks. Letter-bag locks and ledger-locks, ornamented on a new plan.

Lock and key so small as to be contained within half of a hemp-seed husk; and small materials for locks, by two boys of fourteen, Henry and Frederick Aubin.

Secure locks and latches on various principles, and an original method of ornamenting tin goods and panes of glass.

664 **YATES, HENRY, St. John's Square, Wolverhampton—**
Inventor and Manufacturer.

Locks for trunks, drawers, &c.

665 **LEA, WILLIAM & JOHN, Wolverhampton—**
Manufacturers.

Fasteners for sashes. Alarm bells for doors or shutters. Stays for French casements.

Gothic hinge, handle and escutcheon. Ornamental handles for locks, &c.

Brass bell handles. Latches for closet doors and shutters. Brass cabinet locks. Registered double-action rack bolts and lock, suitable for French casements, cupboards and wardrobes; also for hall, warehouse, and doors, either single or folding. Model showing the registered bolt. Night latches.

667 **WHITEHOUSE, CORNELIUS, & Co., Wolverhampton**
—Inventors and Manufacturers.

Tubes and fittings for steam, gas, and water.

Piece of amalgamated Swedish iron, for gun-barrels.

[The exhibited tube is deserving of notice, as the first which was produced, and welded without the aid of internal support. Its manufacture may be thus described:—Iron of the proper thickness is cut into strips, turned up until the edges nearly meet; in this condition, the tube is introduced into a muffle, and when sufficiently heated is welded by passing through a pair of rolls which are placed immediately in front of the heating apparatus.—W. C. A.]

668 **WINDLE & BLYTH, Walsall—Patentees and**
Manufacturers.

Model of Strutt's patent door lock, with glass front to show the internal mechanism. Small model of the lock showing the manner in which the quadrants can be changed, and a new key fitted, so as to render a lost one useless. Cabinet or drawer lock, with springs on the quadrants, and padlocks. Registered locks for drawers, &c.

Finished steel pocket corkscrews, with various useful instruments. Steel phial screws.

Patent compensating steel pens, of large barrel shape. Various steel pens.

Patent penholder. This penholder, which is fitted with springs upon which the fingers rest, is intended to give the feeling of elasticity to the person using the steel pen which it carries. It is shown in the annexed cut.



Windle and Blyth's Patent Penholder.

668A **TUCKER, W. H., Tawnton.**

A double-action detector lock, that can only be opened by its own distinctive key.

669 **MORETON & LANGLEY, 22 Bush Lane, City, and**
Wolverhampton—Proprietors.

General hardware, for building and household purposes, including locks, and other articles, as prepared for home, colonial, and foreign markets, with imitations of Spanish, Portuguese, and other foreign goods.

[It not unfrequently occurs that the rude articles fabricated by native workmen are transferred to the English manufacturers, to be copied and sold to the inhabitants of the countries in which the originals were produced.—W. C. A.]

670 **WALTERS, BENJAMIN & PHILIP, 100 North Street,**
Wolverhampton—Manufacturers.

Patent locks for furniture, doors, &c.

671 **PEARCE, W., 50 High Street, Dumfries, Scotland—**
Inventor.

Safety-lock. The construction of the fixed wards renders it impossible to introduce a picklock or skeleton key. Two floating wards which extend toward the centre of the fixed wards, are attached to prevent a picklock from being passed round the edge and circumference of the fixed wards. The main bolt has three protecting levers, which are alternately acted upon by the key. The upper level has a brass bar upon the escape slot. The main bolt has three projections to the front edge of the lock; and there is a second bolt, thrown by the same key with two projections betwixt the two hinges, preventing any dependence on the hinges.

672 **MITCHELL, JOHN, Redruth, Cornwall—Inventor.**
Improved pistol. Newly-invented safe lock.

673 LEWIS, GEORGE, *High Cross Street, Leicester*—
Inventor and Manufacturer.

Lock with newly-invented circular levers and self-dividing bitted keys—which precludes the picking of the lock, or any improper use of an impression from the key.

674 HORTON, AMOS, *Ashturton, Devon*—Inventor.

Safety-locks on a new principle, applicable for all kinds of doors, dock gates, &c.

675 DOWNS, WILLIAM, *Long Melford, near Sudbury, Suffolk*—
Manufacturer and Inventor.

Improved twelve-bolt lock, adapted for plate-chests, banking-houses, &c. The lock is fastened on the centre of a door, three bolts shooting each way. After the key is withdrawn, when locked, the interior is secured by springs and rising bolts, to prevent its being picked.

676 THRUPP, H. J., *5 George Street, Grosvenor Square*—
Manufacturer.

A variety of hinges of different patterns. These are rising hinges, and are constructed on Collinge's patent. The cut represents a simple and an ornamental form, with the ball and socket joint of the hinge.

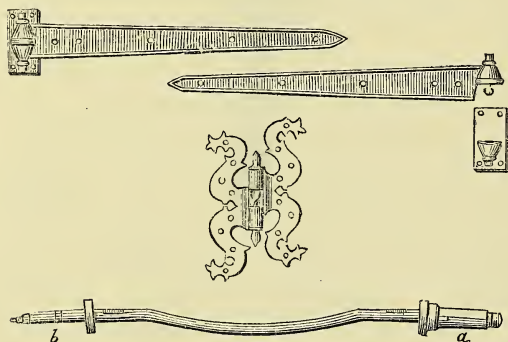

Thrupp's Patent Collinge Hinges and Axle.

Axles upon Collinge's patent. The cut shows this axle at *a* with the collar on, and at *b* with the same removed.

676A GREENFIELD, J., sen., *10 Broad Street, Golden Square*—Inventor and Manufacturer.

Model of door with anti-friction lock and latch, and double secure bolt, to cause the door to shut with little friction and noise.

677 BOULTER, BENJAMIN, *Hull*—Inventor.

New back-fastener for window-shutters, in various forms.

678 BARNWELL, T., & SON, *46 Bishop Street, Dublin*—
Manufacturers.

Wrought-iron double-cased safe, with two drawers, and double doors with secret lock, which cannot be opened by the key, unless the secret be known.

Ornamental hall-door lock. Secret brass desk lock. Iron-rim lock, for prisons, &c.

679 WISSON, RICHARD, *5 Coburg Street*—Inventor
and Maker.

Secret drawn lock, which, unless its internal arrangement be known, cannot be opened with the key. Padlock, with key. Secret padlock, like the drawn lock, to act with dial hands.

680 BOOBYER, JOSEPH HURST, *14 Stanhope Street, Clare Market*—Manufacturer.

External and internal Venetian ventilators. Rim locks, in or-molu cases. Bolt, richly chased in or-molu. Three-bolt mortice and rim locks. Dead locks. Bright boxes of wards and keys, with a variety of other locks, fastenings, &c.

681 BAMBER, JOHN, & SON, *27 Wood St., Westminster*—
Inventors and Manufacturers.

Improved mortice night bolt, for bed, dressing, and bath rooms, to enable persons in bed, or in a bath, to fasten and unfasten the door.

682 TAYLOR, J., & SON, *Loughborough, Leicestershire*—
Manufacturers.

Two bells, with hangings and framework, possessing tones as melodious as single notes, and also attunable with the greatest accuracy to any extent of scale required. The largest is 4 ft. 2½ in. diameter; note, E flat; weight, 21 cwt. 2 qrs. The smallest 2 ft. 6½ in.; note, E flat, octave higher than the large one; weighs 6 cwt.

Hangings for the bells, constructed upon an entirely new invention; the gudgeons of the large bell being fitted in a cast-iron bed.

Plan of cast-iron feaming, far superior in respect to the whole practice of bell-hanging. The brass steps can be adjusted with precision, and will not vary as given to do when in wood.

683 MURPHY, JOHN, *15 Thomas Street, Dublin*—
Manufacturer.

Two church bells, weighing respectively about 28 cwt. and 7 cwt., They answer to the first and last in a peal of eight bells, and in bell-music are called the treble and the tenor of the peal, both are what is technically called "maiden bells," that is, cast in tune from the furnace without any artificial tuning or chipping. They afterwards form a perfect octave, the note being D.

[Bells were anciently called *Nolæ* and *Campanæ*, from their invention by Paulinus, bishop of Nola, in Campania, about A.D. 400. In 610, a French army was frightened away from the siege of Sens by the ringing of St. Stephen's church bells. The ringing of changes is peculiarly English, but the date of their origin is not ascertained; some of the most celebrated peals were invented by one Patrick, a barometer-maker, 1726. The peals of many churches, including those of St. Dunstan's-in-the-East, St. Bride's, and St. Martin's-in-the-Fields, were cast by Abraham Rudhall, of Gloucester, 1684.—H. E. D.]

684 MEARS, C. & G., *267 Whitechapel Road*—
Manufacturers.

Hemispherical bell, five feet in diameter, producing a deeper tone from the same quantity of metal than bells of the ordinary shape.

685 SOBEY, WILLIAM R., *Queen Street, Exeter*—
Manufacturer.

Silver gravy, table, dessert, tea and other spoons; knives and forks, sugar-sifters, sugar-tongs, &c. Model of machine and dies.

686 FEATHAM, MILLER, & SAYER, *9 Clifford Street, Bond Street*—Designers and Manufacturers.

A variety of fire grates, stoves, fenders, &c. Locks, keys, finger-plates, door-handles, scrapers, and knockers; bell levers, fire-irons, &c.

Specimens of wrought-iron gate-work and cast-iron railings, sundry castings.

687 PERRY & Co., *Red Lion Square*—Inventors.
Various specimens of steel pens.

688 ALDRIDGE, JAMES MAJOR, *20 Nelson Street, City Road*—Inventor.

Double-action spring centre and top pivot, showing a portion of a door fixed in shoe, with the spring as fixed in the floor; adapted for doors of any dimension, and such as open both ways; executed in metal, having steel rollers, and case-hardened eccentric.

690 RODGERS, JOSEPH, & SONS, *Sheffield*—
Manufacturers.

Sportsman's knife, containing eighty blades and other instruments, ornamented with views of different cities and other objects; the handle, 12 inches long, made of mother-of-pearl, carved with a boar-hunt on one side, and the death of the stag on the other, from designs by Wehnert.

Sportsman's knife with mother-of-pearl handle, containing fifty-six blades and other instruments, and is only three-quarters of an inch long.

Specimen of cutlery in mother-of-pearl, containing 1851 blades and other instruments.

Carving knife and fork, with ivory handles, 58 inches long; the same 1½ inch long.

Pair of scissors, 44 inches long, with ornamental gilt bows, with the blades etched with different views.

Miniature scissors, complete, which do not weigh half a grain.

Norfolk razor, with cocoa-wood handle, the blade etched with a view of Arundel Castle.

Specimens of cutlery, carved in mother-of-pearl, containing 150 blades, and a timepiece in the centre.

Table, dessert, and carving-knives and forks, with handles of various materials and designs, complete.

Dessert or fruit-knives and forks, with plated and silver blades.

Cake and pine-carvers, with plated and silver blades, fitted up in cases.

Fish-knives and forks, ornamented in plated metal and silver, fitted in cases.

Registered and other bread-knives, with plain and carved wood and ivory handles.

Specimens of pen and pocket-knives of every description, including paper and desk or office-knives.

Knives made for the American market; and for hunting, shooting, fishing, deer-stalking, &c.

Specimens of American bowie-knives, Spanish knives, daggers, &c.

Knives for culinary purposes, as meat, oyster, onion, bread-and-butter, and cheese-knives.

Knives used in various trades, as butchers, shoemakers, glaziers, painters, gardeners, farriers, &c.

Specimens of scissors of every variety.

Razors of various descriptions, including some with handles of horn, ornamented with gold by a new process.

Needle-threaders, by means of which elderly and short-sighted persons may thread small needles with ease.

Pen-machines, for making pens at one stroke.

Specimens, showing the several stages of manufacture of the different articles, from the raw material to the finished goods.

[Sheffield has long been celebrated for its cutlery; so far back as 1296, the town was noted for its iron manufactories "for falchion heads, arrow piles;" and Chaucer immortalizes the locality, by introducing one of his characters as being in possession of a "Shefeld thwytle."

In the manufacture of cutlery three kinds of steel are used, viz., common, shear, and cast steel. Shear steel is in general used for table-knives, scythe, and edge tools. From cast steel, which is susceptible of a fine polish, pen-knives, scissors, razors, &c., are made.

Table-knives are thus forged. Two men are engaged in the operation. The uniform size of the thick part which fits against the handle is produced by swages; the blade is tempered by being plunged into cold water; it is then "brought back to a blue colour," and is then in a condition to be ground.

Forks are forged out of steel, the tang and shank being roughly formed; a portion is left to form the prongs which is flattened, and these then by dies which work in a stamp, a blow from which impresses the prongs, leaving a little superfluous metal between, which is removed by cutting out at a press; they are then hardened and tempered.

Penknives are forged by a single hand: the blade is first drawn out; a portion is left at the cutting off to form the part which is operated upon by the spring, as also to assist in holding when undergoing the grinding process; the small nail mark is given by a chisel; they are hardened in cold water, and tempered on an iron plate.—W. C. A.]

691 MOTTRAM & HAWKINS, 15 *Carr Lane, Sheffield*—
Manufacturers.

An assortment of shoe, butchers', cooks', weavers', bread, palette, putty, glaziers', and farriers' knives, &c.

691A PERRY, R., & SON, *Temple Street, Wolverhampton*—
Manufacturers.

Jelly moulds, assorted patterns; allblaze, steak, and fish dishes; soup tureen; dish-covers; hash dishes and frames; kettles and stands; tea-kettles; coffee machines, pots, and filterers; tea-pots; chocolate pot and mill; carriage, foot, and stomach warmers; cheese toasters; egg poachers; saucepans; egg codlers; water boilers; wine strainer and muller; flour and pepper boxes; soup ladle; slices; baster; fish knife; large bowl; vegetable dish; gravy strainer; baking dishes; sandwich boxes; botanical boxes; nursery lamps; spittoons; sugar boxes; canisters; hot-water and beer jugs; lamps and lanterns; wash-hand basins and jugs; inkstands; almanack case; knife, spoon, and cheese trays; card racks; date cases; spice boxes; toast racks; tea caddies; bread and cake baskets; envelope and paper box; tea trays, &c.

692 LORKIN, JOSIAH, 68 *Basinghall Street*—
Inventor.

Patent egg-beater.

693 LEE, GEORGE, 9½ *Church Street, Paddington*—Inventor
and Manufacturer.

Spring-shank self-adjusting button.
Embossing iron, a new mode of applying heat to finish manufactured woollens, linens, cottons, silks, satins, velvets, &c.

694 KNIGHT & FOSTER, 5 *Eastcheap*—Inventors.

Steel pens, of various designs, in boxes.
Bank of England pens. Swan pens.
Correspondence pens. Anti-corrosive pens.

695 BARRON, FRANCIS, & SON, 436 *West Strand*—
Proprietors.

A variety of locks for doors, drawers, safes, &c., on various principles. Fancy keys.

696 BRITTEN, JOHN, 28 *Alceston Street, Birmingham*—
Inventor.

Improved range, combining the advantages of the ordinary close range and oven grate, with facilities for roasting, baking, and stewing.

Sectional model of the improved range, with description appended.

Small model of a meat-hastener, for roasting two or more joints, at one time, before a narrow fire.

An ash-guard, for preventing the ashes from falling into the dripping-pan.

A steam kettle, with description appended.

An apparatus, which, used in connection with the improved range, is said to convert hard water into soft.

A vertical roasting jack, simple of construction. A slight rotary impulse from the hand about once an hour, is sufficient to work it.

An improved door-fastening, in which the latch-bolt is liberated by simply pulling the handle on one side of the door, or pushing it on the other.

The Stanhope door-spring. The same apparatus in brass, with the case partially removed, to show its action.

697 BOAKE, J. F., 11 & 12 Wellington Quay, Dublin—
Inventor.

Model of signal post, as adopted by the Great Southern and Western Railway Company, Ireland.

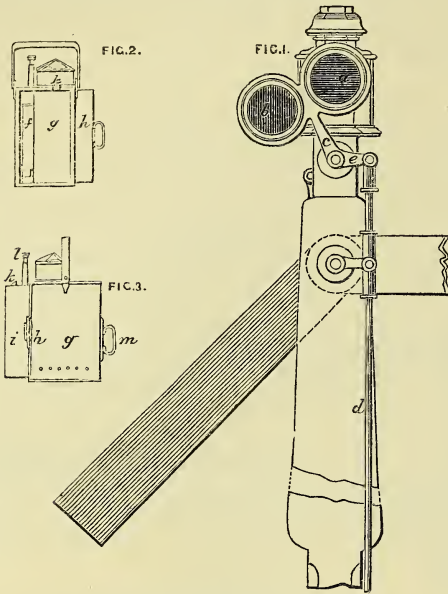

Boake's Irish Railway Signal Post.

Fig. 1, represents a signal post on the Great Southern and Western Railway, Ireland, after having been altered from one of the previous construction, by removing the crown wheels, brackets, &c., and adding a few feet to the vertical working rod, and the coloured glass and its fittings, one of the lamps, somewhat altered, being placed on the top, and the other dispensed with; by this arrangement all requisite signals are given with one lamp only, which being itself motionless, is less liable to accident or disturbance of the light than turned round. Thus one half of the expenses of oil and wick, and more than one half of that of repairs, glass, &c., is saved. *a* and *b*, two circular discs of green and red glass which are connected with the upright rod *d* by the crank *e*, so as to have motion simultaneous with that of the index arm, which is worked in the usual manner by the handle below.

Figs. 2 and 3, lighting-case, in which the burner of the lamp is placed to protect it from being extinguished by the weather while being carried and placed in the lanthorn. The lamp partly shown at *f* is placed (when lighted) in the case *c*, the slide *h* (which is represented partly withdrawn) is closed, and the whole being carried to the top of the post, the nose of the case *i* is placed opposite the door of the lanthorn, and, being pushed forward, is made to enter until the spring latch *k* is made to catch, which holds the case in its place firmly, while the lamp *f*, being pushed forward by its handle *m*, is guided into its proper place in the lanthorn, the spring latch *k* is then liberated by depressing *l*, the empty case detached, the door of the lanthorn is closed.

Signal lanthorn, with improved burner.

Lighting case, for introducing the lamp into the lanthorn in high winds.

Table lamps, with pillars made of bog oak.

Two hand-signal lamps, the one with white and red glass for railway guards, and the other having white, green, and red glass for policemen, &c., on railways.

The advantages of lamps thus constructed are greater certainty and quickness in giving signals, better light, security from accidents or derangement, and greater facility for repairing or glazing than those of the ordinary sort. Registered.

698 COTTAM & HALLEN, 2 Winsley Street—Inventors and Manufacturers.

Iron gates suitable for a park entrance. An attempt to imitate the ancient wrought iron gates at small cost, by combining wrought and cast iron.

Designs in iron for a staircase railing, &c.

700 HARDMAN, JOHN, & Co., Great Charles Street, Birmingham—Manufacturers.

Wrought-iron grate, with brass and fire-irons; the same, mounted with brass; patterns of furniture for doors, cabinets, wardrobes, &c., in wrought-iron and brass. Various articles in brass and metal, for domestic and ornamental purposes. Casket of jewellery, consisting of girdle, brooches, crosses, earrings, &c.

[Much of the older wrought-iron work is highly interesting. Twisted specimens are made by twisting the iron round when in a heated state; complex scrolls, flowers, &c., are made in portions, and fitted together.—W. C. A.]

700A LLOYD & SUMMERFIELD, Birmingham—Manufacturers.

Chandeliers, candelabra, lamps, &c.

701 WALTON, F., Old Hall, Wolverhampton—Manufacturer.

Papier maché trays, with views of Windsor Castle, Holyrood, and Glengariff; the Seasons, and scenes from Retzsch's "Outlines of Faust," with various ornaments. Louis Quatorze ornaments and figures, after Watteau. Shell and sea-weed border, with marine views, &c.

Papier maché loo-table, tazza, cabinet, and vases, inlaid and ornamented. Watteau coal vase, and Stafford scoop.

Patent enamelled foot-bath, toilet-pail and can, printed in colours.

Block-tin dish-covers. Kettles and stands, bronzed.

Patent enamelled sponging and milk pans.

[The application of enamel coating to toilet services is but of recent date, and is a great improvement over the ordinary painting. Such wares are ornamented by the transfer process, viz., by printing from copper plates or rollers on paper, and then transferring the same to the utensil to be adorned (in the same manner as earthenware in the biscuit state is ornamented).—W. C. A.]

702 HANSON, GEORGE, Huddersfield—Inventor.

Dry gas-meter. Water-closet. Four cocks, patent, for water or other fluid.

703 NUNN, ALICIA, 2A Welbeck Street, Cavendish Square—Manufacturer.

New method and apparatus for warming several apartments from an ordinary domestic fire, and ventilating. Warming railway and private carriages, halls, conservatories, warehouses, shops, ships' cabins, &c., without fire therein.

Rotary washing, rinsing, wringing, and steaming machine, for clothes and other textile fabrics, dispensing with boiling coppers, tubs or pails, capable of washing fifty dozen of clothes a day, without tear or wear of fabrics.

Variable apparatus for washing, rinsing, wringing, mangling, and ironing, in one machine.

Apparatus for drying and airing clothes and fabrics.

705 THOMPSON, T. H., C.E., 23 Parliament Street, Westminster—Patentee.

Specimens of ball-valves, which cannot become fixed so as to produce either a flood or a deficiency of water. The perpendicular principle with compensating valve inside, fits them for action under any pressure. They are made of all shapes and sizes to suit various situations, with the inlets at the top, bottom, side, and through, or with flanges.

L. M. N. O. 18 to 20, & 25 to 27; O. 9, & P. 3 to 29.

Sewer trap. It is complete with or without water, and it cannot gape on account of a self-acting weighted latch, which retains the pan in the closest position till the requisite weight has accumulated, when it instantaneously drops, discharges its contents, and as quickly closes. The pan closes against a ring of vulcanized India-rubber, which forms an air-tight joint, at all times.

754 CULVERWELL, WILLIAM, 16 *Charlotte Street*,
Blackfriars Road—Inventor.

Registered portable domestic vapour bath; it consists of a receptacle for water or any medicated fluid, which is heated by a spirit lamp; when hot, the vapour escapes from the sides of several little tubes with flat expanded tops, by means of which it is equally distributed, instead of passing up in a single jet; there is also an elastic tube which may be fixed to one of the flues in the top of the bath, the others being closed, by means of which vapour can be applied locally. The annexed cut represents this contrivance.

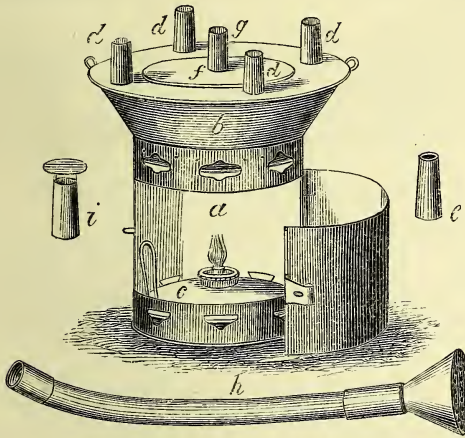

Culverwell's Portable Domestic Vapour Bath.

a, the case; *b*, the reservoir (or receptacle) for containing water or any medicated fluid; *c*, the lamp by which it is heated; *d d d d*, the flues through which the vapour rises; *e*, caps for placing on the flues in order that the vapour may be more quickly generated; *f*, the lid or cover; *g*, a flue to which *h*, an elastic tube, can be fixed, by means of which vapours may be applied locally; *i*, tubes with flat-expanded tops, by means of which the vapour can be more equally disseminated.

755 JEFFCOAT, F. L., 26 *Strand*—Inventor and
Manufacturer.

Improved bedsteads and bed for invalids, &c. Apparatus for heating laundry irons.

792 MAUND, EDWIN, 370 *Oxford Street*—Proprietor.

Cast-iron vase stove, admitting unobstructed vertical radiation; smoke descending.

793 MURRAY, WILLIAM, 20 *John Street, Adelphi*—
Inventor and Manufacturer.

Self-cleansing tubular filter.

Compensating ball for ball taps, with tap complete.

794 LANE, W. R., 226 *Strand*—Inventor.

Economic percolator, or improved registered coffee-pot.

795 MARRIOT, WILLIAM, 89 *Fleet Street*—Manufacturer.

Platform weighing machine, with the principle of the dial weighing machine attached, showing at the same moment the weights of various European countries. Dial weighing machine with jointed iron scale and compound lever bracket, as used at railway stations. Dial weighing machine, with hooks for agricultural purposes,

and with copper scale for domestic use. Machine with chair for weighing persons.

Domestic telegraph for communicating between rooms or houses.

Dynamometer for ascertaining the draught of a plough, carriage, or horse.

Mileometer for measuring distances from 1 mile to 1,000 miles.

Spring roasting-jack.

Machine for showing the muscular power of man in the operation of striking, lifting, or pushing.

796 LOSEBY, E. T., 44 *Gerrard Street, Islington*—
Inventor.

Registered portable crane shower-bath, combining bath and drying-room.

797 DIXON, J., & SONS, *Sheffield*—Manufacturers.

Powder and pistol flasks, shot pouches, drinking flasks, &c., in precious and other metals.

798 WARNER, JOHN, & SONS, 8 *Crescent, Jewin Street*—
Manufacturers, Inventors, and Patentees.

Cocks for steam, water, and gas, of various patterns and sizes. Sluice-cocks and valves for the same purposes.

Check indicator, for registering and delivering checks at the entrance of public buildings, &c.

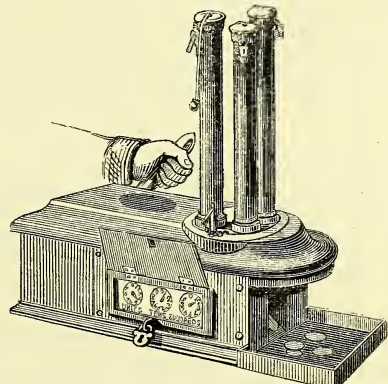

Warner & Sons' Patent Check Indicator.

Registered and patented glass ventilating bricks and windows, for hospitals, factories, dairies, &c.

A set of imperial standard weights and measures, from 1 bushel to $\frac{1}{2}$ a gill, and from 56 lb. to $\frac{1}{4}$ oz. Imperial yard measure. A set of weights and measures adjusted to the proposed decimal system. A set of wine measures.

Bronzed and electro-plated tea-urns and coffee-pots of novel patterns.

Various lamps for burning camphine, common oil, sperm oil, and Palmer's candles. Fancy candlesticks.

Patent counter beer and cider engines. Garden syringes.

Model japanned copper bath, with three-way cock, for the supply of hot and cold water, and copper boiler for the same.

A set of stewpans, saucepans, cutlet, omelet, and frying pans.

Bain-Marie pan and fittings. Stock pot. Turbot-kettle.

Fish-kettles; brass grog kettles; kettles and stands.

A set of 15 musical hand-bells, &c.

A set of 66 musical hand-bells, set to the chromatic scale from F in the bass to F in the treble clef.

Ship water-closet, self-supplying pan.

Water-closet, with double-action pump, requiring no cistern above. India-rubber valve closet.

Patent ship closet, capable of working below the level of the sea.

Patent pan closet, requiring no cistern or valve apparatus. Jennings' patent pan closet. The above articles

are mostly the patent inventions of the exhibitors, and are manufactured at their establishment.

799 WHEELER, C., *Birmingham*—Manufacturer.
Specimens of pearl buttons.

800 DE LA FONS, JOHN PALMER, 13 *Carlton Hill*,
St. John's Wood—Inventor and Patentee.

A lock, with a bolt that links into the striking-plate, which can be easily changed every day to prevent its being picked. Smaller lock.

Model, representing a room with invisible fastenings, for security against danger.

A sash-fastener, which draws the sashes together, to prevent them from rattling, and locks them at the same time. Model, showing the application and arrangement of the bolts. Novel mode of protection for bedroom or other doors, adapted for persons living in secluded situations.

801 JONES, J., & Co., *Sheffield*—Manufacturers.

Rust preventive composition. Samples of steel goods which have been exposed to the weather, the bright parts having been preserved with the composition.

802 ROBERTSON, CARR, & STEEL, *Chantry Works*,
Sheffield—Manufacturers.

Ornamental cast-iron mantelpiece, white and gilt, with burnished steel grate, the fire-brick without a bottom grate, in order to economise the fuel.

Ornamental cast-iron mantelpiece, in Berlin black, with dining-room grate complete. Another, with new arrangement of fire-grate. Provisionally registered. Another, with brass ornaments, and register grate complete.

Bright drawing-room grate. Burnished steel drawing-room grate. A similar one, with gilt ornaments. Brass fenders, some with burnished steel. Sets of polished fire-irons, with brass and steel heads, plain, twisted, and octagon patterns.

804 KENNARD, R. W., *Falkirk Iron Works, Falkirk*, and
67 *Upper Thames Street, London*—Manufacturer.

Self-acting kitchen ranges; self-acting cottage range. Register grates. Arms of the United Kingdom—with the proper shields and crests, upon pedestal, with inscription. Arms of England. Various ornamental castings. Vase and pedestal, for the floor.

805 BAILY, WILLIAM, & SONS, 70 *Gracechurch Street*—
Designers and Manufacturers.

Pedestal stove, with ascending or descending flue, suitable for halls, vestibules, or public rooms; with bronzed candelabra on the top for gas, manufactured in wrought and cast-iron, and brass and enamelled slate.

Fire-place of coloured marbles, with stove, suitable for reception rooms, saloons, &c., manufactured of porcelain, burnished steel, wrought and cast-iron, and brass.

A piece of cast ornamental iron work, suitable for balcony or screen.

Gothic chandelier for gas; and pedestal lamp.

A glass case containing old English door handles, locks, bell pulls, &c.

Gothic stove, with ascending or descending flue, suitable for public buildings, &c.

A Gothic fire-dog, an Elizabethan fire-dog, and an ornamental fire-dog, with brass shield.

806 OYLEY, WILLIAM, & Co., *Parkgate Steel Works*,
Rotherham—Manufacturers.

Specimens of steel suitable for engineering, tool-making, spindles, &c.; also for carriage-springs of every description.

807 CHAMBERS, W., *Brunswick Foundry, Oozells Street*,
Birmingham—Proprietor.

Samples of steel snuffers, showing the principal processes of manufacture, from the castings to the finished state.

Specimens of carpenters' planes, made from malleable iron, and other metals, with planed surfaces, superseding planes made from wood; also one in the rough state, showing the perfect malleability of the iron.

Patent elastic metallic bed-sacking, showing the manner in which it is attached to wooden bedsteads.

808 THOMPSON, F., *Westfield Terrace, Sheffield*—
Inventor and Manufacturer.

Patent gutta percha skates. Specimens of various colours and combinations in imitation of rosewood, boxwood, ebony, marble, &c. These skates possess the advantages of lightness and excellence of material, improved shape and construction, great strength and durability, combined with novelty and richness of appearance.

810 JENNINGS, G., *Great Charlotte Street, Blackfriars*
Road—Manufacturer.

Patent India rubber tube water-closets in section. These closets were chosen by Messrs. Fox and Henderson, and are fixed in the superior refreshment courts of the building.

Patent India-rubber tube cocks, various sorts.

Patent improved cistern valve.

Patent shop shutter shoe, for securing shop shutters without a bar.

Improved mops and brushes for cleaning railway and other carriages, the same being self-supplying.

Patent joint for connecting lead and other pipes without solder.



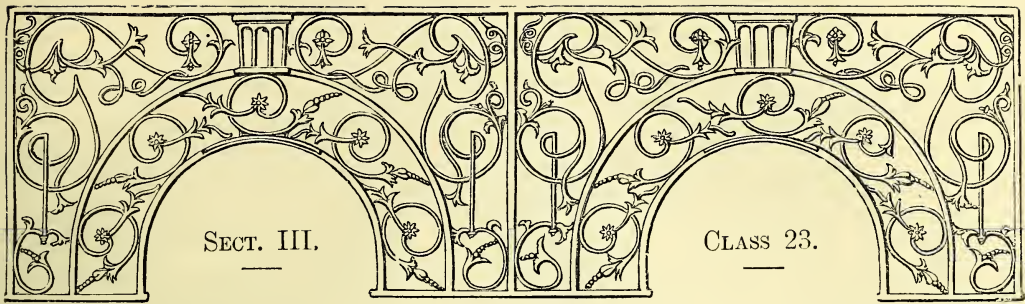

WORKS IN PRECIOUS METALS, JEWELLERY, ETC.

INTRODUCTION.

THE present Class comprises objects of great attractiveness to almost every individual. The opportunity they afford for the display of taste and skill, and even of a high description of art, combined with the intrinsic beauty and value of the material in which these objects are wrought, makes them an extremely interesting study. It is impossible, also, other considerations being disregarded, to suppress a feeling of surprise and admiration at the massive character of many of the articles in this Class, indicating the wealth and resources of the manufacturers. As an instance may be mentioned, a solid silver table-top, fifty-five inches in diameter, and weighing nearly nine hundred ounces. But when it is considered that upon the reduction of the unshapen metal into its present form, the artist and mechanic have both been occupied, and that the result is to indicate not less the talent of the one than the industrial skill of the other, these objects, whatever their size or intrinsic value, assume, in proportion to the degree of talent and labour employed in their manufacture, a new and higher value.

The Class is divisible into the following Sub-Classes:—A. Communion Services; B. Articles of Gold and Silver Plate for decorative purposes, and Presentation Pieces; C. Smaller Articles for more general domestic use; D. Electro-plated Goods of all descriptions, comprehending all that can be executed in Silver and other Metals; E. Sheffield and other Plated Goods; F. Gilt and Or-molu Work; G. Jewellery, inclusive of Precious Stones and Ornaments worked in Ivory, Jet, &c.; H. Ornaments and Toys, worked in Iron, Steel, and any other metal, which are neither precious metals nor imitations of them, as Chatelains of Steel, Chains of Steel, Sword-hilts, Cut-steel Shoe and Knee Buckles, &c.; I. Enamelling and Damascene Work; and J. Articles of use or curiosity not included in the previous Sub-Classes.

The general position in the Building of the articles in this Class is in the South Central Gallery. After passing from the cases containing lace and embroidery, proceeding westward, those which contain the articles in the precious metals are met with, and extend from M. 6 to 22. But several objects properly belonging to this Class, and included in it, are exhibited, as in other instances, in other parts of the Building; the Jewellery and the Great Diamond exhibited by Her Majesty are instances of this description.

Articles in the precious metals are produced in almost all large towns, and those exhibited are consequently derived from a number of different localities. In the metropolis very large and wealthy firms exist, producing annually large quantities of silver goods, upon some of which great expenses are incurred, in order to give to them the character of art-productions. Since the introduction of the beautiful art of electro-plating, Birmingham has supplied very large quantities of silver and electro-plated articles, and a number of extensive factories exist in that town, in which this strictly chemical operation is practised on a grand and commercial scale. In Sheffield the process of plating by fire, that is, by the soldering a plate of silver on an ingot of copper by means of heat, rolling out and fashioning for use, has long been successfully pursued. It has been estimated that the value of the British-made plate annually used in this country amounts to 1,200,000*l.*, and the exports of plate, jewellery, &c., amounted in 1849 to the value of 233,058*l.*

All these varieties in the manufacture of the objects of use and luxury included in this Class, will be found illustrated by the productions of different exhibitors, by many of whom a gorgeous display of plate and jewels is made. Attention cannot fail to be directed to the great Diamond, the Koh-i-Noor; and to the Jewel-case, in the cinque-cento style, exhibited by Her Majesty the Queen. In addition is a table of gold and silver electro-plate, which is an interesting reproduction of an antique subject. The massive specimens of presentation plate exhibited will likewise receive due notice. Among the jewels are several interesting and perhaps unique specimens; one of the latter is a large blue diamond, weighing 177 grains.—R. E.

1 ELKINGTON, MASON, & Co., *Newall Street, Birmingham, 20 & 22 Regent Street, and 45 Moorgate Street, London*—Inventors, Patentees, Proprietors, and Manufacturers.

Glass case of electro-plate: containing large centre table ornament, and two smaller ones; subjects taken from the national games. Centre pieces for fruit; designs, "Crown Imperial" and "Convolvulus." Flower-stand; design, "Sea-horses."

Glass case of silver and electro-plate: containing centre piece and candelabrum, "Oak-tree and stags." Two compotiers for fruit. Three-arm epergne and plateau. Tea and coffee service, complete; engraved. Inkstand; "Milkmaid and goats." Centre piece for dessert service, with three baskets. Gothic tea and coffee service, complete; engraved. Inkstand; "Rebecca at the well." Two centre pieces for fruit; "Games." Gilt candelabrum and plateau. Elizabethan inkstand; the "Dawn of love,"

after Thomas Brooks. Tea and coffee service, complete; embossed. Cake basket, with figures and flowers. Inkstand; "Please remember the grotto." Centre-piece and candelabrum; "Shepherd and sheep." Tea and coffee service, complete; arabesque. Three-arm epergne; Elizabethan. Ornamented Gothic communion service, complete. Pointed Gothic communion service, complete. Flower-stand, with "Bull and horse." Tea-trays of various designs.

Glass case of electro-plate; containing a Vase, intended to represent the triumph of Science and the Industrial Arts in the Great Exhibition; style Elizabethan. The four statuettes on the body of the vase, are Sir Isaac Newton, Lord Bacon, Shakspeare, and Watt, intended to represent Astronomy, Philosophy, Poetry, and Mechanics. On the four bas-reliefs, between the figures, the practical operations of Science and Art are displayed, and their influence typified by the figures on the base; with H.R.H. Prince Albert, as originator and patron of the Exhibition, awarding the palm of honour to successful industry. Height of the vase, four feet; designed and modelled by William Beattie. This vase is represented in the accompanying Plate 11.

Glass case of silver and electro-plate: containing large centre-piece, for eight lights, in the style of the 15th century, with figures supporting baskets for fruit. Venison dish and dish-cover; arabesque. Entree-dish and cover, and warmer; arabesque. Centre-piece and candelabrum; arabesque. Butter-boat; arabesque. Two table-spoons and forks of new designs. Entree-dish and cover, and warmer; arabesque. Meat-dish, arabesque; with Gray's registered gravy well, which separates the fat from the gravy. Two entree-dishes and covers, and warmers. Large centre-piece, with three figures, "Commerce, Wealth, and Fortune." Soup-tureen; arabesque. Pickle and cruet frame; arabesque. Claret-jugs, fish-carvers, and wine-coolers, of various designs.

Glass case of fine art, and art manufactures, containing part of a service of plate, silver and gilt, comprising a dinner and dessert service; designed and adapted from the antique by the Chevalier de Schlick.

Bronzes: the hours' clock case, in electro-bronze; designed and modelled by John Bell; exhibited as a specimen of metal work applied to sculpturesque composition for useful purposes. The hours' circle round the dial; day and night below; a representation of rock and sea; and a pierced ornament, emblematic of twilight, support the composition, which is surmounted with the veil of heaven set with stars. The enamelled dial represents the sun, its centre being a flying phoenix. The body of the composition thus representing Time, is surmounted by Psyche ascending, superior to time.

"Theseus:" reduced by Mr. Cheverton from the original in the British Museum, made for the Arundel Society, in electro-bronze.

"Eve's Hesitation:" statuette in electro-bronze; designed and modelled by John Bell.

"Venus di Medici:" exhibited as a specimen of fine casting.

Commemoration tablet and inkstand; designed by John Leighton.

Plate, representing the days of the week; composed by the Duc du Luynes.

An oak sideboard, ornamented with bronze electrotype bas-reliefs, intended to show the application of electro-bronze to decorative furniture; designed by John Guest; the cabinet work executed by J. H. Taylor, Birmingham.

Geoffrey de Mandeville, Earl of Gloucester, A.D. 1215; made for the Royal Commission of Fine Arts, in electro-bronze, being one of the statues designed for the new House of Lords: modelled by J. Sherwood Westmacott at Rome.

Group, illustrative of Cambro-British history. Tewdric the Great, king of Gwent and Glamorgan, having embraced Christianity, conquers the Saxons at Tintern Abbey, on the Wye. The Welsh king, wounded, urges the pursuit of the flying Saxons, attended by his daughter, and an aged bard proclaims the victory: designed and modelled by J. Evan Thomas, sculptor.

Colossal head of a horse, in electro-bronze, by the Baron Marochetti.

Colossal head of "Ocean," from the Antique.

Bust of H.R.H. Prince Albert, by Baron Marochetti.

Bust of His Grace the Duke of Wellington, by Baron Marochetti.

Bust of the late Sir R. Peel, by John Edward Jones.

Large bas-relief, in electro-bronze, a cast from the original by Fiamingo.

Glass case of silver, containing a group representing Queen Elizabeth entering Kenilworth Castle, A.D. 1575. The subject selected by the Committee of the Warwick Town Plate, for the next September races; designed and modelled by Jeannest.

Glass case of silver and electro-plate: containing sideboard dish, in silver; subject from the "Iliad," designed by Charles Grant. Gilt tankard by Jeannest. Candelabrum, after the antique. Wine-cooler, electro-plated and gilt; subject, from a beautiful marble basin, still existing in the Villa Albani, the "Apotheosis of Hercules," valued as a specimen of Greek workmanship; designed by Kaupert and Gunkel. Race plate: designed by Gunkel, modelled by Rossi at Rome. The bas-reliefs on the frieze represent "Strength, Swiftmess, and Prudence." In the centre a mask of the Goddess of Love. Bracket candelabrum; designed by George Stanton. Set of three sideboard plates; designed by Charles Grant; subjects from the story of "Acis and Galatea." Sideboard plate; the parable of the "Prodigal Son," a reproduction by electro-deposition. Fruit plate, in the Alhambra style. Electrotype copy, in silver, of the celebrated cup, by Benvenuto Cellini, from the original in the British Museum. Silver salt cellar, "Louis Quatorze," by Jeannest.

The following articles, exhibited by the Queen, were manufactured by the exhibitors:—

1. Jewel-case, in bronze, gilt and silvered by the electrotype process. Designed by L. Gruner, Esq., in the cinque-cento style, containing portraits and profiles of the Royal Family.

2. Table of gold and silver electro-plate; the top an electrotype reproduction of a plate obtained and copied for the exhibitors by Chevalier de Schlick; subjects in bas-relief, Minerva, Astrologia, Geometrica, Arithmetica, Musica, Rhetorica, Dialectica, and Grammatica; centre, Temperance and the four elements; the table designed by George Stanton.

[The process of gilding and plating metals, by the agency of electricity, commonly called electro-gilding and electro-plating, has become an important branch of industry, which is rapidly increasing since the patent was granted to the exhibitors in March, 1840. The industrial importance of the manufacture may be gathered from the fact, that in addition to the extensive productions of the patentees, and about thirty other manufacturers in England licensed to use it, the process has been extensively adopted in France and in other countries.

The advantages which plating by this process possess, are,—1st. The application of a white metal, approximating to silver in hardness and colour (as a base instead of copper), upon which the real silver is deposited. 2nd. The removal of all restraint as to form; the most elaborate ornaments, and the most complicated designs which can be produced in silver being equally obtainable by this process. 3rd. Permanency of plating, the coating of silver becoming, by the agency of electricity, one body with the metal on which it is deposited, rather than a mere covering. 4th. Economy in first cost and durability, as well as in the multiplication of works of art of the highest character; and the production, with equal precision and perfection, of copies from the smallest gem to the largest statue, possessing all the accuracy and beauty of the original design.]

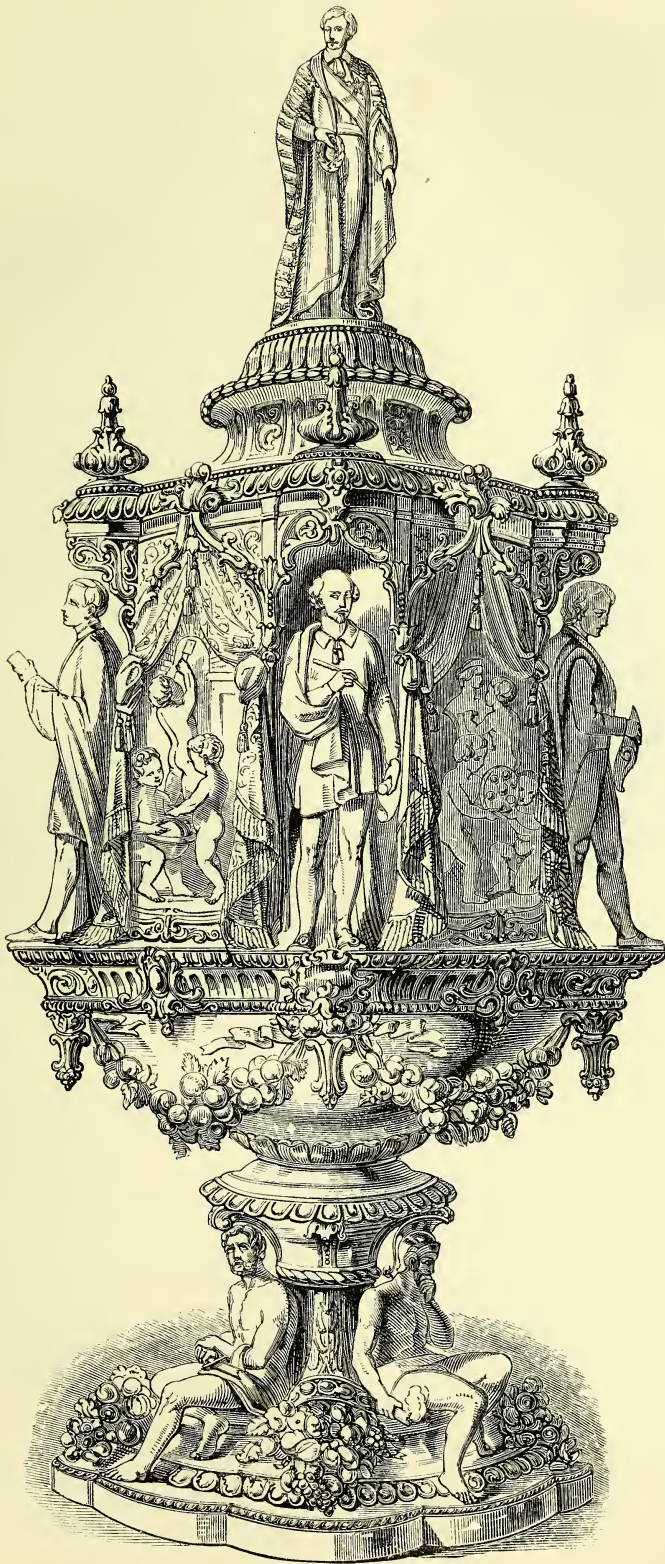

2 MARTIN, BASKETT, & MARTIN, *Cheltenham*—
Manufacturers and Designers.

1. Centre-piece, with figures, representing "Science crowned by Prosperity;" with specimens of wax flowers, in bowl, by Mrs. Whittard, of Cheltenham.

2. Inkstand, with figures, representing "Milton and his daughter under their favourite mulberry-tree;" the former composing and dictating, the latter writing *Paradise Lost*.

3. Silver-gilt toilet-stand, with models of birds, flowers, and animals, suitable for a lady's boudoir.

4. Classical tea and coffee service, designed, modelled, and engraved; the subjects after the antique.

5. Large model of a Great Western steam-engine, to hold two gallons of coffee; made for the Great Western Station at Swindon.

6. Flower-vase, supported by dolphins, with specimens like No. 1.

7. Chased silver claret jug.

8. Bohemian glass claret jug, silver mounted, and a variety of elegant specimens of silver and silver gilt.

9. Registered chatelaine in gold and enamel, arranged to take various-sized watches: it is said to keep the watch steady and safe, and to increase the beauty of the chatelaine as an ornament.

10. Registered "porte fleur brooch."

11. Pearls, manufactured (by Messrs. Sparrow & Son, 11 New North Street, Red Lion Square, London) into a variety of new designs, in brooches, bracelets, necklaces, head ornaments, &c.

12. Specimens of gold jewellery, in bracelets, brooches, rings, &c.

13. Specimens of highly finished gold chains and jewellery, manufactured by Mr. Charles Sparrow, 11 New North Street, Red Lion Square, London.

14. Specimens of chronometer and other watches in their different stages of manufacture.

15. Time-keeper, newly-invented alarm, with instantaneous light, and fire and burglary detector; each can be used separately or be momentarily connected, and so arranged that it can be attached to any number of bells: if only time-keeper is required, all communication can be instantly stopped. The fire alarm can be used with or without voltaic electricity.—Inventor, E. Burgess, 4 Clerkenwell Green, London.

16. The atmithermometer and steam-alarm, an instrument to tell the amount of specific heat required for steam or laboratory purposes: it can be set to discharge a powerful bell from 10 to 400 Fahrenheit, or connected with bells at different parts of premises.—Inventor, E. Burgess, Clerkenwell Green.

Silver-gilt lion inkstand. Glass bowl for containing ice, mounted in silver gilt, the glass engraved with emblematical subjects. Silver-gilt sugar vase, and sifter. Silver thistle inkstand.

Silver toilet bell-handle; design, "Boy stopping his ears."

Gilt rosewater dish, chased centre, with subject from *Acis and Galatea*.

Turquoise blue enamel and diamond watch, with enamel chain and appendages to correspond.

3 REID & SONS, 14 *Grey Street, Newcastle-upon-Tyne*
—Manufacturers.

Silver goods:—Chased claret jug, basket, and tea and coffee service, with emblems of the four quarters of the globe.

Pierced and engraved basket, with border of animals' heads.

Centre-piece for the table; vegetable dish and cover. Model of a coal waggon. Gilt inkstand, vase, and dish, &c.

Two days' marine chronometer. Lock-up time-keeper, for railway guards. Watch, with the latest improvements.

4 PAYNE & SONS, 21 *Old Bond Street, Bath*—
Producers.

Vase in silver, after a marble antique in the Capitoline Museum. This vase is represented in the following cut.



Payne and Sons' Antique Vase.

5 WALL, THOMAS, *Stokes Croft, Bristol*—Designer
and Manufacturer.

Original design in hair-work, after the Tuscan order or architecture, surmounted with a bronze figure of Britannia holding a medallion likeness of Her Majesty; also, ornamented with wreaths, a medallion of H.R.H. Prince Albert.

Ladies' guard, with anchor attached, made without a join. Bracelets, showing a new method of mounting without metal. Ladies' ear-drops, new designs. Watch-guards. Purse.

6 GREENWELL, JOHN, *Whitby*—Manufacturer.

Silver tea-pot, coffee-pot, and tea-kettle, weighing, altogether, two drachms, one scruple, or 140 grains.

7 GREENBURY, ISAAC, *Whitby*—Manufacturer.

Jet necklaces, with appendages attached. Bracelets. Brooches. Candlesticks. Pincushion. Likeness-stand. Earrings. Pieces of rough jet.

10 TUCKER, JOHN THOMAS, *Exeter*—Inventor.

Registered universal brooch protector, attached to a gold box brooch. The protector is a spring under the tongue of the brooch, which not only renders it secure, but removes the usual strain at the joints.

Models of the protector, showing its applicability to every description of brooch.

11 HARDING, JOSEPH, *St. David's, Exeter*—Designer,
Inventor, and Proprietor.

Silver bracelet, with secure snap. Gold and silver bracelet, with the same snap. Bracelet with similar snap, which is applicable to necklaces, &c.

12 ELLIS, HENRY, & SON, *Exeter*—Inventors,
Designers, and Manufacturers.

Eight-day carriage timepiece, with duplex escapement and compensating balance.

Safety chain brooches, for effectually fastening a lady's dress. This brooch is represented in several forms in the following cut. The lower figure represents the brooch opened, it is fastened by pushing the point into the sheath.



H. Ellis & Son's Safety Chain Brooches.

Silver-wire gauze jewel-casket, and a knitting-basket in silver (smelted from ores raised at the Combmartin mines, North Devon).

Silver plate, spoons, forks, &c., in various patterns, among which, "The Leaf pattern," is designed and registered. Silver asparagus fork, different designs. French silver cruet.

Devonshire granite knife-handles. The close texture, great durability, high polish, and colour of the stone, render it particularly adapted for knife-handles.

13 MORTIMER, WILLIAM, 10 *George Street, Edinburgh*—
Manufacturer.

An inkstand. The pebble and jasper agates found in Scotland.

14 MAYER, JOSEPH, 68 *Lord Street, Liverpool*—Designer
and Manufacturer.*Specimens of Roman Plate.*

1. A circular silver waiter, of 24 inches diameter. The centre group, the Queen attended by Concord and Public Security, presenting a laurel crown to the genius of the Industrial Arts, with figures indicating the importance of extending, by means of commerce, the bountiful gifts of the liberal and useful arts to every part of the globe. Fame, bearing the emblems of peace and commerce, proclaiming the memorable event. This centre is from a design by J. B. Crouchley, and was designed for one of the prize medals.

Around the group, in raised Egyptian characters, is the inscription:—"England consecrates to immortality the illustrious names of Victoria and Albert, and the memorable year of 1851." Outside this border are medallions of some of the great men of our country, as representatives of arts, commerce, and civilisation—Flaxman, Wedgwood,

Stephenson, and Watt. Round the whole is a broad border, divided into four compartments by figures of Fame, in each of which is represented the four divisions of the globe appropriately characterised. This salver was executed in competition for the Goldsmith's Company's prize.

2. A large-sized silver waiter, on an original plan. The centre is a raised flat, on which is chased a figure of the Queen, seated on a rock, and a globe unwreathed with a laurel branch, indicative of peace. In a lower circle are represented the principal trading nations of the earth exchanging their manufactures and produce with English merchants. The American giving his cotton, tobacco, &c., for the produce of Manchester and Spitalfields. The African exchanging ivory, palm oil, &c., for calicoes and articles of domestic comfort. The Asiatic transporting his spices and gums in exchange for manufactured articles. The Chinese is offering his tea and other products for cloths, &c.

The border is again raised above the chasing, to an equal height with the centre, and is a broad and richly-chased band, on which are grouped the various articles used in agricultural, mechanical, industrial, and ornamental skill. The centre is relieved by a polished band of bright silver, on which is engraved—"Monopoly is the parent of scarcity, of dearness, and of uncertainty." And on a similar band inside the border—"To Charles Edward Rawlins, Esq., Secretary to the Liverpool Anti-Monopoly Association, 1842 to 1847, presented by the Council and Members."

3. A silver inkstand, with representation of the commercial importance of Liverpool. The ink bottles are formed of the lotus and the cotton plant.

4. A silver cradle. The general form of the body is that of the nautilus shell, with appropriate figures chased in high relief.

The cot rests at each end on axles, so as to allow it to rock backwards and forwards. These are passed through the stems of two large sea-weeds or lavers, as they are locally called. At the base is an inscription to show that the cradle was presented to the wife of T. B. Horsfall, Esq., Mayor of Liverpool, in 1848, by a number of the burghesses of that town, in token of their approbation of his public conduct.

In the interior of the cradle are a mattress and pillow, made of filligree work.

5. Silver epergne: presented by the Liverpool Philharmonic Society to William Sudlow, Esq. The design is to exhibit the influence of music on the mind. Three figures are grouped: Apollo playing on the lyre; an Indian and a Philosopher listening. The figures lean against "a scrolled pedestal" which supports the basin that forms the upper portion of the ornament. The base consists of a tripod, with scrolls and wreaths of roses and laurel, on one of the façades of which is a chased basso-relievo. On the opposite side is also a bas-relief, exhibiting Homer reciting "The Fate of Troy" to his countrymen.

6. Silver candelabrum, having six lights, and a centre dish of glass. The group indicates the connecting of Carlisle and Lancaster by railway. On the base are chasings of views showing the cuttings at Sharp Fell, and the Lune and Lowther viaducts. This piece of plate was presented to George Mould, Esq., chief contractor.

7. The prize plate of the "Liverpool Royal Mersey Yacht Club": a silver vase with two handles; the body is ornamented with scrolls and festoons of flowers in relief; the base, three-sided, and the angles terminated with prows of vessels resting on the backs of dolphins; between the prows are pannels, chased in low relief with the following subjects: Cleopatra sailing down the Cydnus; Queen Elizabeth on the Thames, going to visit Sir Walter Raleigh, off Deptford; and Queen Victoria visiting the Royal Yacht Club, off Cowes. Over each angle stands the bird Liver, the adopted emblem of Liverpool, and surmounting the whole, is Victory standing on a shell holding out two wreaths.

8. Silver tea kettle, coffee and tea set, with chased subjects from the works of Sir David Wilkie.

9, 10. Silver tea kettle, coffee and tea set; the forms from the antique, and the ornaments engraved from the designs of Flaxman; with water-jug to correspond.

11. Basket in the form of a shell with seahorse's head for the handle.

12. Wedgwood ware, silver mounted sugar basket.

13, 14, 15. Claret jugs.

Jewellery.

1. An opal and diamond bracelet, the band removable so that the centre takes out and forms a brooch.

2. An emerald and diamond bracelet.

3. A carbuncle and brilliant bracelet.

4. An enamelled and diamond bracelet.

5. An amethyst and diamond bracelet.

6. A garter bracelet with diamond and opal buckle and rosette.

7. A gold necklace and bracelet, set with brilliants.

8. An emerald and brilliant necklace.

9. A ruby and diamond cross necklace.

10. An opal and brilliant necklace.

11. A double row pearl necklace, with an emerald and diamond pendant.

12. A strung pearl necklace and a brooch to correspond.

13. An enamel painting of Alexander and Cleone.

14. A brooch: a cameo portrait in hone-stone of the wife of Albert Durer, executed by himself.

15. A carbuncle brooch with diamond pendants.

16. A purple enamel and brilliant knot brooch with pendant.

17. A blue enamel and diamond brooch.

18. An emerald and brilliant engraved gold knot brooch.

15 WEST, JAMES, & SON, *Dublin*—Manufacturers.

Brooches, bracelets, neckchains, pins, rings, and pendant ornaments, composed of silver, oxidised silver, and gold and oxidised silver mixed, embellished with Irish pearls and other gems, copied from antique Irish ornaments.

16 CONNELL, DENIS, 10 *Nassau Street, Dublin*—Carver and Producer.

Cup, carved, with designs from scenes at Donnybrook fair. Inkstand with figures carved on the top, representing Irish strolling musicians.

Brooches, bracelets, necklaces, paper-knives, and card-cases, mounted in Wicklow gold and Irish diamonds, all made of Irish bog oak found in the lakes of Killarney—with new designs.

Bookstands, chessboards, card-cases, &c., from arbutus wood, grown at the lakes of Killarney.

17 MOSLEY, JULIUS, 46 *Wicklow Street, Dublin*—Designer and Executor.

Carved casket, in white and red Irish bog yew, with subjects in alto-relievo from sacred history, and allegorical representations of "Virtue and Vice." The wood found on Lord Farnham's estate, county Cavan.

18 BENNETT, THOMAS, 75 *George Street, Dublin*—Manufacturer.

Ark of the covenant, in silver.

Silver-chased large salver. Presentation cup. Chased claret jug. Engraved claret jug.

Chased Dresden pattern tea-kettle and stand.

Engraved hexagon tea-kettle and stand. Dresden tea and coffee service. Hexagon tea and coffee service.

Plain hexagon tea and coffee service, with Irish wolf-dog button.

Chased scroll and flower tea and coffee service.

Chased and engraved children's cans.

Antique chased and pierced salt cellars, with mustard pot. Antique and chased dessert sugar baskets.

Small melon bachelor tea-pot. Plain Pompeii cream jug.

The above articles have been manufactured from silver obtained from the mines of Ireland.

Case containing fine gold jewellery and bog oak, all manufactured out of Wicklow gold and Irish pearls. In this collection is a newly-invented flexible gold bracelet, suited for either a watch or miniature; exhibited for novelty.

20 WATERHOUSE, GEORGE & SAMUEL, 25 *Dame Street, Dublin*—Inventors and Manufacturers.

Registered brooches, adapted to cloaks and shawls, from the mineral products of Ireland.

21 NICOLL, W., *Prince's Street, Edinburgh*—Manufacturer.

Gold pens, pointed with iridium. These pens are alloyed with a certain proportion of platinum, and the points are iridium, an extremely hard metal.

23 MARSHALL & SONS, 87 *Great George Street, Edinburgh*—Manufacturers.

Set of accoutrements for a Highland dress, with chased silver mountings studded with carbuncles and cairngorms, viz., goat-skin purse, broad sword, dirk, powder-horn, skeen dhu, or hunting-knife; plaid brooch; sword-belt, body belt; shoe buckles; pistols; Athol bonnet; stag's head.

Silver claret jugs, of antique shape and figures.

Scotch pebble trinkets and jewellery, viz., bracelet; paper-cutter; quaihs, or drinking-cups; brooches; chate-laine, studded with various Scotch pebbles; bracelet, with stones found in Aberdeenshire, Perthshire, and Forfarshire; bracelet, with gold and cairngorms; silver and gold brooches with cairngorms; brooch with pearls and amethysts.

24 RETTIE, M., & SONS, *Aberdeen*—Manufacturers.

Gold and silver mounted granite, porphyry, and topaz bracelets, brooches, pins, &c. One of these brooches, is shown in the annexed illustration.



Rettie's Ornamental Brooch.

25 THOMPSON, F. H., 10 *Brandon Place, Glasgow*—Manufacturer.

Decanter stand, to hold three decanters and one claret jug. Coffee urn, supported on figure of Time. Coffee urn on figure of Atlas. Tea-kettle on gilt figure of Time.

Liqueur frame. Egg frame, with china bottom, and egg cup. Cruet frame, with glass bottom. Toilet frame. Flower-stand, with terra cotta figure; all of new designs. Inkstand, taken from the antique. Inkstand, modern. Goblet, supported on figure of Cupid. Cheese-stand and cover.

Large centre-piece, with figure of Mercury supporting flower-basket. All the articles exhibited are in electro-plate.

26 BAIRD, WALTER, 72 *Argyle Street, Glasgow*—
Producer.

A Scotch ram's head, each horn measuring 3 feet 5 inches; mounted as a snuff-box and cigar-case, in gold and silver, adorned with a cairngorm and Scotch amethyst stones.

27 LISTER & SONS, *Newcastle-upon-Tyne*—
Manufacturers.

Medals, struck in commemoration of the Queen's passage over the bridge at Newcastle-upon-Tyne.

Snuff-boxes, card cases, novel jewellery, and Highland ornaments.

Silver claret jugs. Coffee and tea pots, basins, ewers, and cups. Fish and table knives and forks.

Eight-day spring clock, with lever escapement and compensation balance. Chronometer timepiece.

28 SPURRIER, WM., *Birmingham*—Manufacturer.

Electro-silver and gilt services, containing tea and coffee-pot, sugar-basin, and cream-ewer: Victoria, Brunswick, Venetian and cottage patterns. Dish and cover; Louis Quatorze; and cottage patterns.

Table candlesticks; arabesque and Brunswick patterns. Chamber candlesticks; cottage pattern.

Cake-baskets; pierced and Victoria patterns; saving-kettle, with lamp; cruet-frames, Gothic, pierced, and roll patterns; and mustard-pot and salt-cellar.

Pepper-box, arabesque pattern; mounted jugs; tea table, dessert, mustard, salt, and gravy-spoons; table and dessert forks and dessert-knives.

[The discovery, or rather application, of the principle of the electrotype process is due in this country to Thomas Spencer, of Liverpool, and was suggested by observing the exact copy in metal of some imperfections at the bottom of a cell in one of his batteries, which he had been using for scientific experiments. The electrotype process differs from the magneto process only in so far as the exciting agent is produced by the immersion of zinc, platinized silver, &c., in a solution of sulphuric acid, which is connected by wires or rods with the deposit trough. In this solution is suspended the articles to be gilt or silvered: the strength of the same is maintained by plates of the metal, of the same kind as is to be deposited, being suspended therein.—W. C. A.]

29 HILLIARD & THOMASON, *Birmingham*—
Manufacturers.

Silver fish-knives and forks, taper-stands, brooches, bracelets, corals, card-cases, knife, fork, and spoon, card-baskets, snuff-boxes, paper and cake knives, bouquet holders, mustards and salts, and a variety of other fancy goods.

30 CARTWRIGHT & HIRONS, *Birmingham*—
Manufacturers.

Plated and silver-gilt cruets, inkstands, baskets, &c.

31 MARRIAN, FRANCIS, *Cannon Street, Birmingham*—
Manufacturer.

An epergne, or centre-piece. Etruscan jugs, plain and engraved. Antique coffee-pot and stand.

Chased salvers, registered pattern. Table and piano candlesticks, plated and gilt.

Elizabethan inkstand. A chalice. Toilet candlestick.

Vine pattern decanter-stand. Toast-stand, registered pattern. Antique castor frames. Toast-rack, wheat-sheaf handle.

Candlesticks, for Indian shades. Engraved tea and coffee service. Dish-cover. Soufflet dish and stand.

32 WILKINSON, T., & Co., 15 *Great Hampton Street, Birmingham*, and 41 *Tavistock Street, Covent Garden*—Manufacturers.

Articles of electro-silver plate upon German silver, viz. :—

Centre-piece and plateau, Triton and Sea-nymphs, under a canopy of real coral.

Candelabrum and plateau, subjects from "Paul and Virginia," &c. These are represented in the cut annexed, and in the second cut on opposite page.



Wilkinson's Plateau.

Flower vase (and plateau), supported by a vine.

Tea-urn, an Etruscan vase, supported by oak branches, children playing introduced on the base. This is represented in the following cut.



Wilkinson's Etruscan Tea-urn.

Venison dish and cover, the handle—a group of deer, represented in the first cut on the next page.

Oval salver, ornamented with the bryony and engraved centre. Dessert dishes, &c.

Salad-stands, coral, dancing girl, sitting figure, and foliage. Wine-cooler, embossed panels.

Medallion basket, "Watt," modelled by Taylor.

Liqueur and cruet frames, Gothic style, and bryony ornaments. Inkstands. Round salver. Butter-cooler, engraved, and ruby. Sugar-basket and candlestick. Mustard-pots and salt-cellars, embossed and pierced.



Wilkinson's Ornamental Venison Dish.



Wilkinson's Candelabrum.

[The metallic base of electro-plated articles is formed of German silver, or a hard white metal composed of copper, nickel, and zinc, the several parts being held together by hard solder, which fuses only at a very high temperature. Under the old method, the figures here introduced must have been cast in silver; by the present process they are cast of the white metal. After being rifled or chased, they are electro-plated.—W. C. A.]

33 GOUGH, WILLIAM, 11 Parade, Birmingham—
Manufacturer.

Electro-plated articles:—Consisting of Elizabethan epergnes; and vine, with figures.

Vine candelabra. Oak tree centre stand. Cruet frame, supported by griffins, &c. Spirit frames. Egg stand. Baths, coolers, and round salt, antique. Fruit stands and baskets. Flower stands.

Piano candlestick, oak tree, with figure of Cupid shooting dove. Registered waiters. Sugar basin, antique. Plateau, representing a bank with cattle, &c.

34 COLLIS, GEORGE RICHMOND, Church Street,
Birmingham—Manufacturer.

An electro-plated wine-cooler, a model, to the scale of one-fourth of the celebrated Warwick vase.

A solid silver table-top, 55 inches in diameter, weighing nearly 900 ozs., the surface engraved with stars, crescents, &c., for his Excellency the Governor of Aleppo. Solid silver salver. Several centre ornaments. Branches and glasses.

Five tripod candelabra, designed after the antique by Sir Gardiner Wilkinson. One of the candelabra is represented in the adjoining cut.

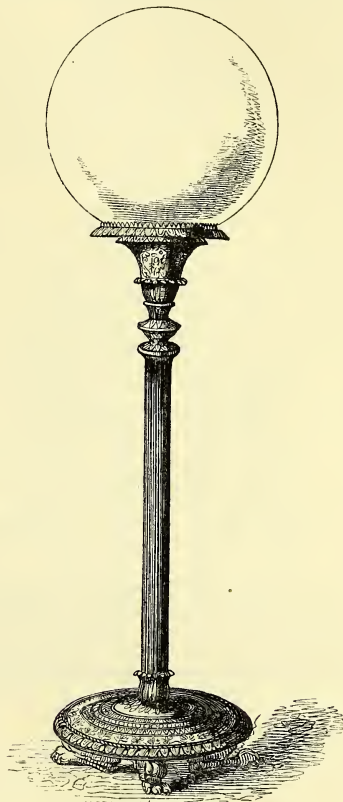

Collis's Antique Candelabrum.

Centre ornaments on tripod stands, and composed of vine leaves and trellis work, with cut-glass dish for flowers. subject, the Golden Age.

Fruit basket. Venison dishes; vegetable dishes and covers; hash dish and cover, with stand and lamp.

Ice-pail, small model of the Warwick vase, the body in crystal and silver ornaments.

Plateau, worked in foliage and flowers, with border of lilies. Salvets, with borders; boys holding baskets of flowers, &c., "Boys and panther," "Four seasons," &c., "Assiette montée."

Dessert plates, dish, and basket. Tea-urn, Elizabethan; tea-urn, with military emblems. Soup tureen, with massive eagle handles and feet.

Claret jugs; cut-glass, and electro-plated, vine mounted; and Pompeian design, engraved.

Entrée dishes and covers. Bread and cake baskets. Salt-cellars. Fish and dessert knives and forks. Muffineers. Mustard-pots. Muffin plates and covers.

Tea and coffee services. Tea-kettle and stands. Chamber and table candlesticks. Sugar vases. Soup tureen and cover.

Glass cruet and liqueur stands. Small salver, vine border; engraving, "Bacchus and Silenus." Salvets, with subjects: The Great Exhibition Building, and Pan and Silenus. Gothic communion-service, engraved.

An urn, adapted for railways, constructed for supplying, simultaneously, tea, coffee, and hot water.

Machine, in solid silver, for slicing cucumbers at table. Spoons and forks, in electro-plate, of various patterns.

Dressing-cases. Glass butter-tubs. Toast-racks. Snuff-boxes. Waiters, engraved and chased. Bottle-stands, electro-plated. Decanter carriage, "Boy and panther."

Inkstands. Dish-covers. Soy frame. Inkstand, sarcophagus shape, with Belisarius on cover.

Chandelier, in glass cut on both sides, enamelled in various colours, relieved with burnished gold, begun by the late George Grundy, for George IV., and completed by Messrs. Collis & Co.

Series of 60 medals, in bronze, illustrative of the Holy Scriptures, with a reverse to each. Medals of the Kings and Queens of England, from William the Conqueror to Alexandrina Victoria. Grand national medals, illustrative of the principal events during the late war. Series of 16 medals, illustrative of the sciences. Medals: agricultural, horticultural, botanical, of eminent persons, and belonging to various societies.

[This manufactory owes its existence to the spirit and industry of the late Sir Edward Thomason, to whose enterprising zeal the manufactures of Birmingham and its neighbourhood are deeply indebted. To copy, in the size of the original, the celebrated Warwick vase, was a labour and a risk which few individual manufacturers, at that period, would have attempted (its weight is upwards of $4\frac{1}{2}$ tons). The extent to which he carried the silver-plate trade, as a medallist, button-maker, &c., still attest his energetic, enthusiastic, and liberal ideas.—W. C. A.]

35 HAWKSWORTH, EYRE, & Co., *Sheffield*—Designers, Manufacturers, and Proprietors.

A silver centre-piece, to serve as a candelabrum or epergne, with five branches, cut glasses, and tripod stand or plateau.

An assortment of articles in various styles, German silver, and electro-plated, with silver embossed edges and ornaments:—

Tripod candelabrum, in Egyptian style.

Flower-stands, in different patterns and styles of ornament.

Corner dishes and covers; table dishes and covers; soup tureen, *en suite*, in the Italian style.

Bread and cake baskets, in various styles and patterns. Salvers or waiters, of different patterns. Liquor and cruet frames, different in patterns, and glasses. Silver-mounted claret-jugs, coloured and plain.

Embossed oval coffee tray, with coffee and tea pot, sugar-basin, cream-jug, and tea-kettle, in the old German style.

Embossed plated coffee-tray, chased scrolls, with coffee and tea pot, sugar-basin, and cream-jug, embossed and engraved.

Butter-cooler, with glass and cow knob. Silver butter-cooler, of engraved and alabaster glass.

Sugar-baskets, assorted patterns, and coloured glasses. Embossed tea-canisters. Decanter and hock bottle stands.

Table, pianoforte, and bed-room candlesticks, in various styles. Snuffer-trays and snuffers. Salt-stands. Mustard-pots.

36 BRADBURY, THOMAS & SON, *Sheffield*—Manufacturers.

Coffee and tea services, consisting of coffee pot, tea pot, sugar basin, and cream ewer, of various patterns, with kettles and stands for the same.

Kettles and pitchers, plated and engraved.

Plateau, scroll pattern.

Tea urn, fluted antique pattern.

Double dish and warmer, with pierced and chased border.

Antique bread basket, engraved and pierced with antique massive mounting. Waiter and liquor frame for the same.

Liquor and cruet frames, various patterns.

Chamber candlesticks, Elizabethan.

Inkstands, pierced and engraved.

Bottle stand, pierced, antique.

Cake basket, engraved, French pattern.

Candelabrum.

37 HARRISON, JOHN, *Norfolk Works, Sheffield*—Manufacturer.

Epergne, of Venetian pattern, cut crystal basin, ruby glass lining, and coloured Bohemian glass cups.

Round chased waiter, with open border.

Wine coolers, or ice pails, of vine pattern; and Flemish style.

Liquor frame, open scroll border, with opaque gilt bottles.

Oval-shaped chased cake basket, with Italian open-work handle. Claret jug, Louis Quatorze pattern.

Table candlesticks, plain, fluted, scroll, and leaf pattern. Chamber candlesticks, bead and plain tulip pattern.

Centre ornament, Oriental pattern, with ruby enamelled gilt glass.

Centre ornament, Oriental foot, scroll socket, cornelian glass, green and gilt scollop edge.

Flower vase, Victoria pattern, ruby glass lining. Flower vase, Italian pattern, with drooping foliage, chrysoptase lining. Registered flower vase, Italian pattern, with turquoise glass. Violet stand, with Bohemian coloured gilt glass cup.

Sugar basket, rose foliage in panels, ruby glass lining.

Sugar basket, plain, pierced with bead mount, turquoise lining. Cream ewer, foliage and chain pattern, with ruby glass lining. Cream ewer, plain, pierced with bead mount, turquoise lining. Kettle and stand, fluted and engraved, with vine pattern stand. Toast racks, antique and Tudor pattern.

Hock bottle and stand, vine and scroll patterns, with Bohemian bottle.

The above articles are electro-plated on imperial metal.

Large engraved oval waiter. Round engraved waiters, with and without moveable border.

Plain oval dish-cover, Elizabethan handle, engraved shield. Fluted oval dish-cover, with ornamental handle. Registered dish-cover, with moveable mount, columbine pattern. Registered corner dish, with moveable mount. Oval-shaped corner dish, with loose warmer.

Liquor frame, foliage pattern, cut crystal bottles. Oval-shaped engraved bread basket. Round-shaped bread basket, with shaped drooping edge. Unique pattern claret jug, with vine stem handle and foot, engraved.

Candelabra, varied pattern. Table candlestick, Elizabethan pattern. Registered chamber candlestick, water lily pattern. Chamber candlestick, shell and leaf pattern.

Tea and coffee services, Chinese and Louis Quatorze patterns. Kettle and stand, Chinese pattern. Registered toast-rack, serpentine frame, with scroll pierced panels. Butter coolers, Elizabethan pattern, with cut crystal glass, and saw-pierced ornament, ruby glass lining.

The above articles are electro-plated on nickel-silver.

Tea and coffee service, Italian pattern (sugar basin and cream ewer with ruby glass linings), electro-plated on Britannia metal. Cruet frames, various patterns, electro-plated on nickel-silver, and imperial metal.

[Britannia and imperial metals are both composed of tin, regulus of antimony, and small portions of copper and brass. Articles of a complicated form, such as ornamental candlesticks, tea-pot handles, feet, &c., are cast in brass moulds. The bodies of these are produced by what is called *spinning*—a process by which fine thin discs of rolled metal are made to take the convex or globular form of the object desired: this is effected by the disc being placed against a suitable wooden block or chuck, which revolves in a lathe; and by means of the pressure of a steel tool or burnisher, the thin plate of metal is pressed against, and finally takes the form required; when, in two or more parts they are soldered together by tin

solder, which is melted by the heat of a blowpipe, and completes the adhesion of the two parts: the "mounts" are attached in the same way. Among the late improvements in electro-metallurgy has been the successful application of this mode of silvering to the softer and less valuable metals, which has given an impulse to the production of articles elegant in form, and cheaper in proportion as the value of the foundation on which the deposit is made decreases.—W. C. A.]

Plain fiddle pattern, and registered pierced pattern spoons, forks, &c., electro-plated on nickel silver.

[Spoons, forks, &c., are formed by being cut out of sheets of rolled German or nickel silver; the instrument used to effect this purpose is an ordinary press and tools: the ornamentation is produced by a die and stamp, as also the hollow in the mouth of the spoon; the forms are then corrected by hand, cleansed, and the electro-deposit made thereon, as in other articles; they are brushed with a revolving brush, wet, beer-grounds being used; they are then burnished by hand.—W. C. A.]

38 DIXON, JAMES, & SONS, *Sheffield*—Manufacturers.

Best Sheffield plate.—Dish-cover, melon pattern, registered. Soup-tureen and stand, coffee-tray, corner-dish, tea-urn, &c., of the Stowe pattern, antique style.

Sculptured silver candelabrum and epergne, with crystal glass, weighing about 750 ounces, illustrative of the four seasons, designed by Vincent Nicholson; also a massive plateau, encircled by rock, sea-gulls, and shells, forming a base of 33 inches diameter.

Silver coffee and tea service, designed from the *Nipenthus*, or pitcher plant, with silver salver modelled from a leaf of the *Victoria Regia*, furnished by Joseph Paxton, Esq., gilt in parts. Registered.

Silver chalice, antique, gilt in parts; silver chalice and paten, with bas relief, gilt. Table-dish and cover, with spirit-lamp. Grecian double dish in two sizes, with soup-tureen. Round silver tea-tray, weighing 184 ounces. Oblong coffee-tray, vine pattern; coffee-trays: oval, chaste, beaded pattern. Entrée dish, with warmer and spirit-lamp.

Case of Wellington and beaded pattern spoons and forks. Unique tea service, plated on Britannia metal; ivy pattern and pagoda pattern.

Specimens of Britannia metal illustrated from the ore to the finished article, showing the compound, and the various stages through which each article passes.

Hot-water venison-dish, with cover. Beef-steak dish, with cover and corner dish. Swing-kettle, with copper bottom and spirit-lamp. Registered pattern tea-pot, in various sizes. A great variety of tea-pots and other articles.

Shooting-tackle. Gilt silver powder flask, engraved; with a variety of pouches, gun and pistol flasks, dram-bottles, and shot-belts, with every kind of tops or chargers.

39 SCHOOL OF DESIGN, *Sheffield*—Producers.

Carved oak cabinet and sideboard.

40 ROBERTS & HALL, *Sheffield*—Manufacturers.

Tea-tray, antique pattern, chased centre. Tea-urn, chased, and silver-mounted. Tea-kettle and stand, chased, with spirit-lamp. Tea and coffee service, chased, consisting of tea and coffee pot, sugar-basin, and creamer, gilt inside.

Spirit-frame, embossed, with cut flint-glass bottles. Liquor and cruet frames, silver-mounted and pierced, with cut blue glass bottles, in separate compartments, which can be unscrewed and taken off for cleaning; on a new principle. Cruet-frames, silver-mounted, embossed, and pierced, with cut flint-glass bottles. Egg-frame, with cups, gilt inside, and gilt spoons.

Antique salvers, with plain border and engraved centres. Round salvers, with embossed silver, shell, vine, and scroll borders, and chased centre. Bread-basket, with embossed silver shield, leaf-pattern border, and chased centre. Bread-basket, with silver vine border and pierced and chased centre. Cake-basket, with silver border and chased centre.

Registered toast-racks, one designed from the wheat plant, and another plain; both with oblique bars. The annexed cut represents the registered toast-rack, designed from the wheat-plant.

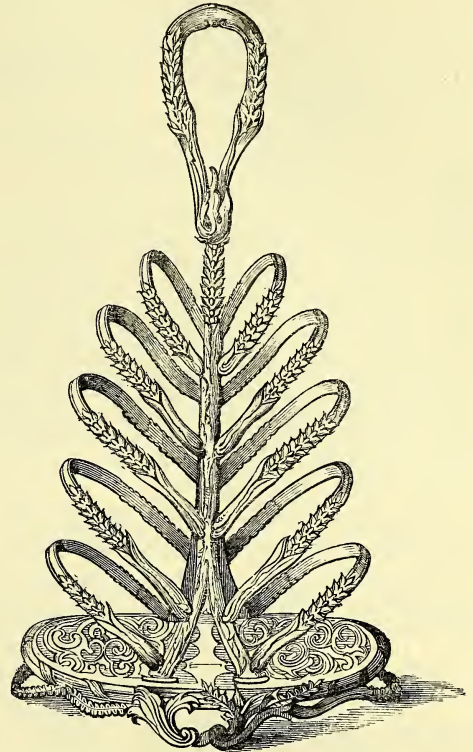

Roberts and Hall's Registered Toast-Rack.

Candlestick of square shell pattern. Antique round candlestick. Round candlestick, with silver shield and leaf borders. Candlestick of embossed silver vine pattern. Round candlestick, silver mounted. Round shaped or fluted candlestick, with silver border.

Centre-piece, embossed with plateau, holding large crystal centre dish, and four small ones, having four arms with sockets for lights. The centre can be taken out and another introduced, which holds four additional lights; the small crystals can be removed, and sockets used, making in all 12 lights, when the crystal basins are not required.

Embossed silver-mounted bottle-slide. Pierced twisted-top bottle-slides.

The above articles are all electro-plated upon nickel silver, and are put together with hard solder, which effectually prevents any danger of their coming asunder at an ordinary heat.

41 OWEN & LEVICK, *Sheffield*—Manufacturers.

Silver-plated and Britannia metal ware.

42 PADLEY, PARKIN, & STANFORTH, *Sheffield*—Manufacturers.

Specimens of plated goods, plated with silver upon German silver in the ingot, exhibited for quality and durability.

Engraved epergne and plateau. Plain and chased dish-covers. Candelabrum or centre-piece, with glass centre

for flowers. Chased kettle and stand, with coffee and tea-service *en suite*. Raised chased kettle and stand. Engraved coffee and tea-service. Fruit-baskets of different designs. Small-sized round chased waiters. Large oval chased coffee-tray.

Hexagon pierced, chased, and pierced cruet-frames. Pair of four-bottle pierced cruet-frames. Round flower-border corner dish, with hot-water stand. Soufflet-dish, and pierced liquor-frame, with coloured bottles. Pierced decanter-stand, and engraved egg-frame. Pierced ink-stand.

Butter-coolers, with engraved cover and stand, and chased cover and pierced stand.

Large and small engraved table candlesticks, with three-light branch, and engraved bed-room candlestick *en suite*. Plain gadroon candlestick. Sundry mustard-tankards, salt-stands, &c.

Ingot of German silver, with a piece of standard silver upon it, ready for plating. Ingot of metal, plated, as taken out of the furnace. Sundry pieces of plated metal, rolled down from the ingot, ready for working.

[The operation in the present instance is performed by heat and pressure, and the superficial covering of the foundation is effected previously to the commencement of the manipulation of the workman who makes the article. A piece of silver or gold is placed upon an ingot of the metal to be plated, and is introduced into a furnace, a flux having been put between the two surfaces, when, at a given point of heat, fusion of the two surfaces takes place, and complete adhesion is effected. The ingot is then rolled out into sheets by the ordinary process of rolling between steel rollers.—W. C. A.]

43 BROADHEAD & ATKINS, *Sheffield*—Manufacturers.

Silver plate. Electro-silver plate. Britannia metal goods. Mounted jugs, &c.

A group of electro-plated articles for the tea-table, coffee and tea-pot, cream-ewer, and sugar-basin. This group is represented in the following illustration.

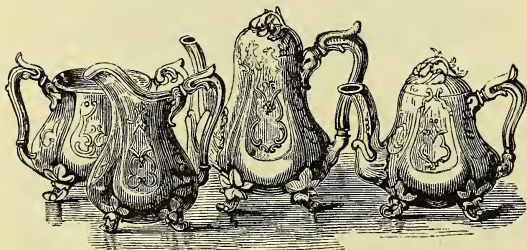

Broadhead and Atkins' Electro-plate.

44 WILKINSON, HENRY, & Co., *Sheffield*—Manufacturers.

Epergne, with Triton holding branches. Epergne, with bacchanalian figures. Candelabrum, with figure of Mercury. Candelabrum, with Grecian ornament. Ice-pail (Warwick vase), with pedestal. Silver pine-vase, with plateau, arabesque, and grapes. Sugar-vase and cover, of similar design. Silver sugar-stand, arabesque design. Tea-urn, with embossed scrolls and flowers. Coffee-trays, oval, chased, and with reeded shell borders.

Registered venison-dish and cover, Elizabethan, with side-dish and cover, with hot-water stand, of similar design, and soup and sauce tureens.

Registered side-dish and cover, Tudor style of ornament.

Silver decanter-stands, pattern, vine and Satyr's head, with grapes. Silver bread-basket, with bacchanalian masks. Bread-basket, with water-leaves, shell border. Silver claret jug, with design, "Hebe," embossed. Silver claret jug, with "Nautilus" design.

Candlesticks, silver massive, antique, fretwork, with masks, hexagon.

Registered silver inkstands, of Elizabethan and Egyptian design.

Silver cruet-frame, hexagonal, pierced. Silver cruet-frames, of arabesque and crescent designs. Silver communion-service, four pieces in mediæval style, with engraved texts, and ornaments. Silver communion pocket-service, in case. Silver font, of the 14th century, in case. Silver cups for children, embossed, with Tudor and fuchsia ornaments. Silver taper-stand, clustered pillar. Silver muffineer, embossed. Silver mustard-tankard and salt-cellar, with Gothic leaf ornament. Silver butter-cooler, in Tudor style, engraved.

45 CRESWICK, THOMAS, JAMES, & NATHANIEL, *Sheffield*—Manufacturers.

The whole of the articles in the following list are plated by fire, and have silver mountings, except the figures on centre piece, No. 851, the borders of plateau, No. 854, and waiter, No. 871, which are plated by the electro-type process.

Candelabra, plated on German silver. Centre-piece. Epergne and plateau. Fruit stand, plated on German silver. Centre stand and plateau, plated on German silver. Flower stand, plated on German silver.

Candlesticks, with branches, plated on German silver. Venison dish and cover. Corner dishes and covers, plated on German silver. Casserole and cover. Casserole and cover, plated on German silver, with warmer.

Ice pails, plated on German silver. Double shell salt-cellar, gilt inside. Saltcellars, silver feet, gilt inside. Bottle stand, silver shield. Carriage, with a pair of bottle stands, silver shield. Waiters. Waiters, plated on albatra. Candlesticks.

Bread basket, plated on German silver, silver handle. Cruet frame, silver handle, feet, and tops. Inkstand, plated on German silver. Embossed tea kettle and stand, plated on German silver, with tea pot, sugar basin, and cream ewer. Table dish and cover.

46 M'GREGOR, M., *Perth*—Manufacturer.

Ram's head, mounted in silver, with Scotch stones, as a snuff-box and a cigar-case.

47 MEYER & MORTIMER, *George Street, Edinburgh*—Designers and Manufacturers.

Ornaments of different Highland regiments in Her Majesty's service. Also, patterns of the tartans and kilts, with specimens of dirks, purses, brooches, and other accoutrements worn by each.

49 THORNHILL, W., 144 *New Bond Street*—Maker.

A steel chatelaine

51 BIDEN, JOHN & FREDERICK, 37 *Cheapside*—Proprietors and Manufacturers.

Twelve signet rings, designs the property of exhibitors:—

a. Bloodstone, *Vesica Piscis*, scroll ornaments, standard gold.

b. White cornelian, enamel scale armour, standard gold.

c. Bloodstone, ornaments taken from the Saxon heptarchy A.D. 700, standard gold.

d. Red cornelian, enamelled red, after the Arabesque style, 22 carat gold.

e. White cornelian, enamelled green, after similar style, 22 carat gold.

f. Sardonyx, in cameo, shield for engraving, Norman style A.D. 1100, standard gold.

g. Red cornelian, on the shank a globe, wreaths of olive, motto PAX, in enamel, standard gold.

h. Bloodstone, Saxon shield, ensign of St. George, in enamel, 22 carat gold.

j. White cornelian, antique shield, shank bearing the crosses of St. George, St. Andrew, and St. Patrick in enamel, 22 carat gold.

k. Oriental amethyst, anchors entwined by cables, Union jack in enamel, 22 carat gold.

l. Black and white onyx, in cameo shield for engraving, enamel Arabesque ornaments, 18 carat gold.

m. Sardonyx, in cameo fancy scroll, 18 carat gold.

[The art of gem, cameo, and seal engraving is of considerable antiquity, as the number and excellence of the specimens in the collections of our own and other countries abundantly testify, exclusive of the evidence of Holy writ, that a knowledge of the process was familiar even to the Jews. The following expression occurs in Exodus: "With the work of an engraver on stone, like the engravings of a signet, shalt thou engrave the two stars with the names of the children of Israel." The Barberini vase is one of the most successful specimens of relief engravings on a material akin to precious stones.—W. C. A.]

n, o, p. Solid standard gold Roman rings. Sardis and bloodstone.

Ten gold seals, viz. :—

1. Chased amethyst, 22 carat. 2. Sporting horses, &c., crystal. 3. Fox-hunt, crystal. 4. Greyhound, red cornelian. 5. Round jug with compass, bloodstone. 6. Fox-scalp handle, red cornelian. 7. Scroll-handle swivel, seal and wafer, red cornelian. 8. Coloured swivel, white cornelian and bloodstone. 9. Scroll, fine sard. 10. Leaf-handle, red cornelian.

Various desk seals mounted in gold, designed by exhibitors, the agate handles of foreign manufacture.

A library seal, cairngorm, engraved with the arms and badges of H. R. H. Prince of Wales, mounted in silver gilt, the figures representing the four Seasons, supporting the handle, surrounded by wreaths of oak from the top; one of the badges of H. R. H., in enamel on gold, designed by exhibitors.

A brooch in enamel, modelled from the Victoria Regia lily.

Impressions of seals engraved on stone, steel, or gun metal; also impressions taken by Rider's process on wax, the manufacture of Messrs. Hyde.

[Seals are at all times executed in intaglio (or sunk); in cameos the reverse. The surrounding surface is cut away, and the subject is shown in relief with its minute details: not unfrequently effect is given by selecting a stone or other material stratified; the superior surface forms the subject, and the surrounding portion being cut down to the dark-coloured strata, or layer, shows the figure, &c., in relief with additional effect.

The process of seal, or gem-cutting, is performed in a manner similar to glass engraving, viz., by means of a small lathe and copper-cutting tools, which revolves with the spindle, and is moved by ordinary treddles as a foot lathe; the tools are occasionally touched with diamond dust and oil, which facilitates and effects the indentation or incision; the more minute the work the smaller the tools—they are in many instances mere points. Care, a knowledge of form, and no small amount of taste, in connexion with good vision, is essentially necessary to the seal-engraver; the hand and eye being the only guides to assist him in the production of such minute and laborious works.—W. C. A.]

A fine gold key, set with stones. Manufactured by Drury Freeman, 41 Gee Street, Goswell Street.

A likeness in profile of the Queen, composed of 1,114 fine and perfect diamonds, rose cut. Manufactured by W. Stacy, 17 St. Alban's Place, Edgeware Road.

52 EATON, ELIZABETH, 16 *Irvine Crescent, Cripplegate*—
Manufacturer.

Silver forks, spoons, &c.

53 WOODBRIDGE, THOMAS, 4 *Albion Road, Holloway*—
Proprietor.

Chased silver design—Death on the Pale Horse, from the painting by West. The silver is only 1-32nd part

of an inch in thickness; the legs of the horse, as also the string of the bow, are all beaten up, and not soldered on.

54 RAWLINGS, JOSEPH, 85 *Portland Road, Regent's Park*—Manufacturer.

Specimen of miniature frame, mounted and engraved—imitation of or-molu.

55 MILLS, MICHAEL, 17 *Ossulston Street, Somers Town*—
Producer.

Embossed and chased salver, produced from a plain sheet of silver; subject—"Aurora, or the Hours," after Guido; border, after the Tredacna shell.

Silver gilt claret-jug, in the Venetian style, after the pattern of one in the possession of the Andromini family at Venice.

Prayer-book, in Italian taste, mounted in silver on purple velvet, with a fine chasing in the centre.

56 INDERWICK, JOHN, 58 *Prince's Street, Leicester Square*.

Smoking-pipe of Meerschaum, with a carved representation of the death of Nelson, mounted in gold and silver.

Registered tube for smoking-pipe. By compressing the tube with the fingers, the smoke is conveyed to the lips without the trouble of inhalation.

[Meerschaum, out of which the above pipe is made, is a mineral substance found in the islands of Samos, Negropont, &c.; it is at times used by the Turks as a substitute for fuller's-earth; also in the manufacture of tobacco-pipes. The ease with which it is worked adapts it to the construction of ornamented articles.—W. C. A.]

57 MORTIMER, W. H., 12 *Harley Street, Cavendish Square*—
Inventor.

Mechanism in gold for rectifying irregularities in the growth of the teeth.

58 DURHAM, J. B., 456 *New Oxford Street*—
Manufacturer.

Cast-steel chatelaine, in the antique style, with improved scissors and tablet.

59 CLEAL, WILLIAM, 53 *Poland Street, Oxford Street*—
Manufacturer.

Specimen of workmanship in human hair.

60 WARRINER, WILLIAM, 16 *Charlotte Street, Fitzroy Square*—Manufacturer.

A finished or-molu miniature frame, set in crimson velvet.

62 LOEWENSTARK, A. D., 1 *Devereux Court, Strand*—
Designer and Manufacturer.

Silver filligree ancient incense-urn, lady's table bell, and pepper-castor, in three divisions, made of some thousands of pieces of silver wire. The first division is to admit the incense through a small door. The second contains the bell. The third or top division is the pepper-castor. The top and straight part unscrews to admit the pepper. The whole is put together with 37 screws. Different specimens of filligree work. Masonic pearls.

63 RESTELL, RICHARD, 35 *High Street, Croydon*—
Designer and Manufacturer.

Registered cylindrical brooch protector: in gold, silver, gilt, and black, with ornamental pendants and chains; also with novel spring pendant holder.

64 GOODWIN, CHARLES—Proprietor.

China vase, mounted in metal gilt. Bloodstone cup, mounted in silver gilt, and ornamented with a variety of stones. Pastile burner.

65 WISEDILL, G. V., 1 *Gloucester Place, Prospect Row, Walworth Road*—Inventor and Manufacturer.

Specimens of registered fastening for brooches, watch-protectors, &c. Specimens of self-acting double spring swivels.

66 ABBOTT, GEORGE, 4 *Percy Street, Bedford Square*—
Producer.

Bronze statuette; the Duke of Wellington at Waterloo.
A silver embossing of His Royal Highness Prince Albert, and of "The Sisters," after Stephanoff.

A cast, in silver, not chased, from an embossing ("The Inconstant") after Stephanoff.

67 MORLEY, THOMAS, 140 *High Holborn*—Proprietor.

Electro-gilding on soft metal, adapted for medals or any other purposes.

68 WOLFF, LOUIS JOHN, 45 *Upper York Street, Bryanston Square*—Designer and Manufacturer.

Desk seal, mounted in gold, closely set with turquoise, spiral pattern with band of pearls, surmounted with large pearl, white cornelian stone for engraving.

69 GOWLAND, THOMAS, 5 *Leadenhall Street*—Inventor.

Registered design for spring catch fasteners for brooches and bracelets.

70 BAKEWELL, WILLIAM, 25 *Red Lion Street, Clerkenwell*—Artist, Inventor, and Manufacturer.

Specimens of hair for lockets, brooches, &c. Inscriptions and initials of pearls. Prince of Wales' feathers in hair.

71 LEE, BENJ., 41 *Rathbone Place*—Manufacturer.

Bracelets of new design and construction, composed of human hair and gold, mixed throughout; the hair plaited by hand. Brooches of varied designs, composed of several shades of hair. Hair guard-chain, of a new pattern. Albert guards with keys of hair set in gold. Breast-pins and crosses.

72 SEYMOUR, EDMUND & JAMES, 40 *Gerrard Street, Soho*—
Proprietors.

Small enamelled gold vase, with portraits of Her Majesty and Prince Albert (painted on enamel in imitation of cameos by J. Haslem). The vase designed, engraved, and enamelled by the exhibitors.

[Enamelling has not been neglected in this country. Enamelled trinkets have been found in ancient British barrows. The Saxons practised the art, as is proved by the enamelled jewel, made by command of the great Alfred, now at Oxford; and the gold enamelled cup given by King John to the corporation of Lynn, in Norfolk, is evidence that the Normans were acquainted with the art. Besides the tomb of Edward the Confessor, in Westminster Abbey, there are other proofs that enamelling was known in England in the middle ages.]

73 HOPE, HENRY THOMAS, 116 *Piccadilly*—Proprietor.

Casket, containing a blue diamond, weighing 177 grains, mounted as a medallion, surrounded by brilliants, and supposed, from its size and colour, to be unique. This diamond is represented in the annexed cut.



Hope's Blue Diamond Medallion.

[Diamonds are found white, pink, orange, yellow, green, blue, and black. To estimate their value, according to Jeffries, multiply by itself the number of carats of weight, and again multiply the sum by the value per carat; the value depends on the quality of the stone. It was supposed impossible to cut them until the year 1486, when the discovery was made at Bruges of using diamond dust for that purpose. The Mogul diamond, now in possession of Her Majesty, weighs 279 $\frac{3}{8}$ carats, was estimated by Tavernier at 468,959*l.*, and by Jeffries' standard, would be worth about 622,000*l.* The Empress of Russia, in 1772, bought a diamond of 729 carats. The Regent, in the French crown jewels, weighs 136 $\frac{1}{4}$ carats.—H. T. H.]

[The diamond consists chemically of the element carbon, in its purest form. When perfectly pure, it is absolutely without inherent colour. The colouring matter arises from the presence of some foreign substance in extremely minute proportions. Sir Isaac Newton, from the refractive properties of the diamond, long since made the happy conjecture that it was a combustible body, which experiment has frequently demonstrated.—R. E.]

74 HARDING, DANDO & Co., 23 *Hatton Garden*—
Inventor and Manufacturer.

Specimens of patent spiral fastening, which may be securely attached to any article of dress without sewing; adapted to buttons, studs, pins, brooches, &c.

75 BAYLEY, W., *George Street, Goswell Street*—
Manufacturer.

Specimens of electro-gilding on metals.

76 CAMPBELL, ANDREW, 43 *Tottenham Court Road*—Inventor, Designer, and Manufacturer.

Registered standard gold cornucopia, designed to combine the three several uses of a dress brooch, a flower-holder, and a watch protector.

77 FORSTER, ERNEST, 19 *Queen Street, Haymarket*—
Producer.

Silver-gilt table-spoon, representing Jenny Lind as Alice in "Robert le Diable."

Silver snuff-box, embossed bas-relief. The cover representing Daphnis teaching Chloe to play the flute.

78 EDWARDS, ROBERT, 26 *Liste Street, Leicester Square*—Manufacturer.

Specimens of different colours and tints of enamel for jewellery.

Gold rings with enamel. Portraits, in enamel, of the Queen, Prince Albert, Shakespeare, and the Duke of Wellington. Gold waistcoat-buttons, coat-buttons, and shirt-pin, with enamel portraits of dogs.

79 BUSS, HENRY, 13 *Great Newport Street, Leicester Square*—Designer, Engraver, and Enameller.

Medallion: an assemblage of shields, displaying the heraldic devices, in incised enamels, on gold and silver, of the nations whose industrial works are shown in the great Exhibition of 1851. The shields are supported on either side by branches of laurel and olive. The entire composition is surmounted by the Royal Crown of England, in proper colours.

[Incised enamelling is a branch of decorative art capable of extensive application to the adornment of gold and silver plate, jewellery, cabinet, and other work.]

80 ZIMMERMAN, GODFREY & SIMON, 38 Old Bond Street—Manufacturers.

Porphyry and malachite casket, mounted in or-molu, with corners set with gems. Silver equestrian statuette of the Queen, on ebony pedestal; silver figure of Prince Albert. Silver figure of Charles the First.

Two small mounted agates, enamelled and set with jewels.

81 STOCKEN, CHARLES, 53 Regent Street—Manufacturer.

A variety of dressing-cases.

83 GASS, S. H., & D., 166 Regent Street—Proprietors.

Silver dessert service, of new design, modelled from water plants in Kew Gardens (by permission of Sir W. Jackson Hooker, F.R.S., Director).

No. 1 represents the *Nymphaea thermalis*, or Hungarian water lily, in flower; the leaves intended to receive the various fruits, and the stems springing from rock-work, on which are growing several rock-plants, the *Blechnum occidentale*, of South America, and the *Polypodium*, of the East Indies. Each leaf is capable of supporting a weight of more than 6 lbs.

No. 2 represents the *Nymphaea rubra*, or red water lily, of the East Indies, in flower; the rock-work decorated with the *Piper speciosum*, the *Blechnum occidentale*, and the *Polypodium*.

No. 3 represents the *Calladium* and flower; the rock-work decorated with the *Piper speciosum*, and the *Blechnum occidentale*.

No. 4 represents the *Dillenia speciosa*, which has not been seen to flower; the rock-work decorated with the *Blechnum occidentale*.

Silver centre-piece, illustrative of a scene in Egypt; the plinth supported by a sphinx; the group of figures are "the women of the country fetching water from a well;" and the centre is a representation of the Doum palm-tree.

Silver sugar-vase, composed of the sugar-cane surrounding a glass dish, engraved in delineation.

A silver salt-cellar, representing the *Nymphaea rubra* growing on rock-work, supporting a glass.

Silver corner dish, with dome cover, and open-work flower border, the handle representing the Iris flower.

Silver-gilt cup, with figures (after a design by R. Redgrave, Esq., R.A.).

Pair of silver-foliage pattern taper candlesticks.

Silvered jewelled dessert set, in Elizabethan style, consisting of knives, forks, and spoons, set with gems of various kinds, variously finished, some silver, others silver-gilt, and others partly silver and gilt.

Brooch, in the style of the cinque-cento period, set with precious stones; representing a Gothic niche, composed of carbuncles and diamonds, with a figure, in brilliants, of "Britannia holding a trident" and an ancient paddle, in rubies, standing on a shell, underneath which is the subdued dragon, terminating with three pearl drops.

Carbuncle and diamond bracelet, with portraits of the Queen and H. R. H. the Prince of Wales (after the painting by R. Thorburn, Esq., A.R.A.), executed in niello, the revival of an art of the 11th century, and a novelty as applied to miniature portraits (the engraving by Mr. J. J. Crew).

Silver gauntlet niello bracelet, designed by D. Maclise, Esq., R.A., descriptive of "The Promised Gift," "The Gift Ordered," and "The Presentation," interlaced with decorative illustration (the engraving by Mr. J. J. Crew).

[Niello was the art of line engraving on metal, the interstices of which were filled up with a dark metal composition. It was used before the art of taking of impressions was known, is described by the monks Theophilus and Cellini, and its most celebrated professor was Maso Finiguerra, of Florence, in the 15th century.—H. T. H.]

Williams's patent moveable button, secured by turning the shank; adapted for articles of dress, and applicable to any substances used in the manufacture of buttons.

Vase, 24 inches in height and 18 inches in circumference, composed entirely of human hair, with the mountings and ornamental parts in metal gilt. Executed by Mr. J. Woodley, 31 Cursitor Street.

84 PARAVAGUA & CASELLA, 3 Brabant Court, Philpot Lane—Importers and Manufacturers.

Branch of natural rough coral, of great size and value. Carving, representing Bacchus, of the finest coral, with pedestal and fittings.

Gigantic child's coral. Coral bracelet, set in gold. Necklace of diamond-cut coral. Pair of coral drops, diamond-cut, &c. Diamond cut coral pieces. Coral cameos.

A row of 12 of the largest coral beads, called Codini.

Long row of large coral beads, called Caporesto Moro.

Large bunches of coral beads; 36 rows assorted large sizes, called Grossezze Moro; 30 rows regular sizes, called Filze Moro; 54 rows assorted sizes, called Mezzanie Moro; 71 rows small sizes, called Smezzati Moro.

Rows of finest pink coral beads; of pipe coral beads, called Olivette; of diamond-cut coral. Coral negligées.

[Coral is the internal skeleton, or organ of support, of a species of polype (*Corallium rubrum*), of which numerous individuals live in organic association, under a ramified form. The polype individuals are provided with eight arms, or tentacula, by which they seize their prey, and a stomach in which it is digested. The common connecting flesh is nourished, and the supporting axis of coral is secreted, by a continuous system of vessels common to, and conveying the nutriment from, the several individual polypes. The *Corallium rubrum* belongs to the order *Anthozoa* and the class *Polypi*. It is most common, and arrives at its greatest perfection, on the southern shores of the Mediterranean Sea.—R. O.]

85 BARLING, JOSEPH, 90 High Street, Maidstone, Kent—Designer and partly Maker.

Table and dessert spoons and forks, ornamented in a novel manner with enamel to form a part of a dessert service, exhibited to show the applicability of enamel to the ornamenting of various articles of silver plate.

86 NASH, ELIEZER (late JOSHUA BUTLER), 30 Coppice Row, Clerkenwell—Designer and Manufacturer.

Pencil-cases:—Engraved, coloured gold, and set with turquoise; elongated enamelled; tortoiseshell, gold-mounted; engine-turned bright gold; engraved elongated; triangular; engine-turned hexagon; and engraved round silver.

Penholders:—Engraved silver-gilt; and on pearl and inlaid ivory handles.

Set of silver engraved and gilt instruments, comprising etui-case, crochet-needle, scissors, penknife, pencil, stiletto, tumble, and bodkin.

Pens:—Gold and palladium, with nibs of iridium.

Solid pressed tortoiseshell snuff-boxes, inlaid and mounted with gold.

Tablets:—Solid book, ornamented like the preceding; solid book, silver inlaid and mounted; pearl, inlaid with turquoise, silver-mounted; and ivory, similarly ornamented.

Trochus shell, inlaid, with engraved gilt mountings.

Tortoiseshell paper-folder.

Set of tortoiseshell instruments, gold inlaid and mounted, comprising paper-folder, pen-knife, pen-holder, pencil, and desk seal.

The elastic palladium point, or lead-holder, an improvement applied to pencils, was invented by Mr. Joshua Butler, and has been in use 20 years.

87 PHILLIPS BROTHERS, 21 Cockspur Street—
Inventors and Producers.

Equestrian statuette, subject—a British Life-guard, modelled from life, and executed in oxidised silver and gold. The arms and accoutrements are made to detach from the figure.

This statuette is represented in the accompanying illustration.



Phillips' Equestrian Statuette.

Two miniature copies of the same, mounted on malachite pedestals; and two on foot, adapted for seals or statuettes.

Two miniature statuettes in gold and silver, subject—Lablache, as Caliban.

Statuette composed of oxidised silver and gold; subject—a colour-sergeant of the Scots Fusilier Guards, modelled from life. Two miniature copies of the same adapted for seals or statuettes, &c.

This statuette is shown in the annexed cut.

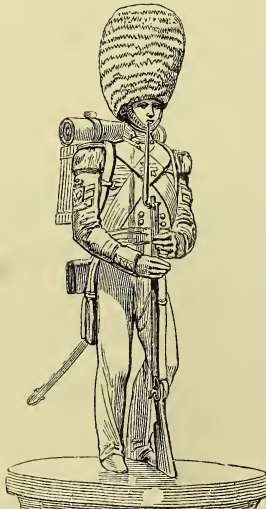

Phillips' Infantry Statuette.

Casolette in bloodstone, chased with the attributes of the Life-guards; the same with attributes of the Foot Guards.

Ornament, forming either a Sevigne brooch or chate-laine, formed of topaz, mounted in gold and brilliants. Brooch-stone cameo head, surrounded by large brilliants, with crest and coronet of small rose diamonds.

Curious ornament of Chinese manufacture, in massive fine gold, and numerous figures in relief.

Two-day ship chronometer, with the latest improvements, previously tested at the Royal Observatory, Greenwich.

Gold watches, with various escapements, &c. A series of alarums. A series of gold swivels. An inkstand and writing apparatus, composed of carved coral, imported from Gagliardi, of Naples.

A set of chessmen and boards in silver and gold, in the *renaissance* style, ornamented with enamel, precious stones, and pearls. The chief figures are portraits of the German Emperor Charles V., and his daughter, Margaretta of Parma; a stadtholder of the Netherlands; King Francis I. of France, and his daughter, Margareta of Valois; and a casket in silver, coral, various precious stones; and four malachite slabs.—Messrs. C. M. Weisshaupt, Hanau, near Frankfort, S. M., Proprietors and Producers.

Bouquet of flowers rising out of a classic vase, composed of silver, and wrought by hand.—Messrs. Thomas Strube and Son, Leipzig, Saxony, Proprietors and Producers.

Bracelet composed of three extraordinary specimens of pink topazes, mounted with brilliants in fine gold and green enamel. Bracelet, with four fine enamels, mounted in massive chainwork of gold. Bracelet, with large model curb chain in engraved gold. Bracelet, with bouquet of diamonds and green enamelled leaves.

Necklette and brooch, in carbuncle, diamonds, turquoise, blue enamel, and gold. Skull vinaigrette, modelled in gold.

Series of twenty signet rings, after antique models, in standard gold.

Series of fifty finely modelled gold pins, sporting and classical subjects.

Series of eleven pins, composed of precious stones.

Gold desk seal, figure of stag on white cornelian. Gold brooch, stag and dogs. Gold brooches, composed of various gems. A set of original sleeve ornaments.

Sets of studs, composed of diamonds, emeralds, rubies, opals, and other precious gems. Sets of vest buttons, composed of rubies, turquoise, and opals.

Two-day marine chronometer, jewelled in six holes, helix balance spring, &c., in mahogany box. Another, jewelled in five holes, in rosewood box.

A library clock, in ebonised carved maple case. Duplex escapement compound chronometer balance, spiral spring, jewelled in six holes, beats the seconds, strikes the hour and repeats, &c., with glass shade and stand.

Carriage clock, in engraved and gilt case, patent detached lever escapement, jewelled in six holes, compound chronometer balance, &c., with glass shade and stand. Another, with gold balance, &c.

Camp timepiece, patent detached lever escapement, jewelled; enamelled seconds dial plate; in circular bronze case with engraved and gilt handle, and spring adaptation to support an inclined position; with travelling case, &c.

Carriage timepiece in a gilt and engraved case; patent detached lever escapement, jewelled, &c.; portable from its flatness, and rendered secure, on standing, by a new application for feet; travelling case, &c.

A vase of fine gold, out of which rises a flower (carnation); composed entirely of brilliants and rubies with enamelled leaves. Adapted also for brooch or head ornament. A collection of specimens of enamel.

88 ADAMS, G. W., Hosier Lane—Manufacturer.

Dessert service, silver gilt; the Canova pattern; and in silver. In these are introduced that artist's "Dancing flower-girl reposing," and "Hebe." The figure on the

heel of spoon and fork "Sappho." The accompanying illustration represents a knife and spoon of this service, the ornamental parts of which only are seen.



Adam's Silver-gilt Knife and Spoon.

The Tudor pattern table, dessert, and teaspoons; table and dessert knives and forks, gravy spoon, and fish carvers.

Table spoons and forks, Corinthian and Palm patterns.

Various sugar ladles, sugar tongs, grape nippers, teaspoons, lobster scoops, and ice tongs.

89 FRENCH, J., & SONS, 5 Newcastle Place,
Clerkenwell Close—Manufacturers.

Almondine signet ring, set in gold, with the motto. "Virtute et industria."

Lady's safety chain, of the hexagon Brazilian pattern.

Gold bracelet, of the cage pattern, with locket suspended.

Gold earrings.

Gold chains, of the Brazilian, cable, cylinder, and secret-link patterns.

Cage and cable pattern gold chains.

90 HERRMANN, A., 4 Oxendon Street, Haymarket
—Designer and Manufacturer.

Laurel wreath, with imitation of lace, cut with scissors. The ornamental paper work consists of two large leaves in the shape of palm leaves.

Bouquet, of various-coloured hair, in a new style. A family bouquet with key. Similar bouquet ornamented with pearls.

91 WHEELER, GEORGE & M., 28 Bartlett's Buildings,
Hoborn—Manufacturers.

Jewellery and trinkets of gold, silver, agate, precious stones, and pearls, consisting of brooches, bracelets, chains, earrings, lockets, watch protectors, thimbles, pencils, keys and seals, charms, paper knives, cigar cases, snuff-boxes.

Specimens showing the progress of a gold bracelet from the pure metal to the complete article.

92 HARVEY & Co., 126 & 128 Regent Street—
Proprietors.

Silver candelabrum. The base is triangular, and composed of shell work, marine plants, and water, issuing through apertures formed about the ornament, and losing itself in shells placed to receive it. On the angles are three principal figures; Venus seated upon a shell, exhibiting the golden apple; Siren playing upon a harp; and Siren, entwined in a net, and presenting to Venus strings of coral. On the stem, of a spiral form, is a young Triton, crowning Venus with a wreath of pearls. Upon the summit, surrounded by marine plants, is Cupid. Springing from the upper part of the stem are three branches (to bear two lights each), composed of sea-weeds and shells; the whole forming a marine composition.

Silver fluted claret-jug, from the antique.

Silver plain water-jug, from the antique.

Silver water-jug, from the antique, with subjects engraved from designs by Flaxman.

Silver statuette of Mercury, designed by Woodington.

Pair of silver-chased candlesticks, "Boys and dolphin."

Silver-chased Italian pattern tea and coffee service, consisting of tea-kettle with lamp and stand, coffee-pot, teapot, sugar-basin, and cream-ewer.

Chased silver-gilt rose-water dish, with antique chased centre.

Chased silver-gilt sacramental service, designed by Cundy, consisting of offertory dish, three patens, two chalices, and flagon.

Pair of silver-gilt mounted Vernet Martin vases.

Gold watch, invented by S. Boreham, to beat seconds, and to strike every minute or 60th second, so that seconds may be counted by the ear, while the eye is otherwise engaged, as in observing the stars passing the meridian, in counting the pulse, &c. It has only one extra wheel, and can be applied to the movements generally used. It has an improved escapement, embracing the fine actions of the chronometer and the strength and durability of the lever escapements.

94 SMILY, WILLIAM ROBERT, 9 Camomile Street—
Manufacturer.

Chased silver coffee-pot, representing a hall in a desert; the handle and spout formed of oak, entwined with ivy; heads of Her Majesty and his Royal Highness Prince Albert, are introduced upon the body; designed by Mr. King; chased by Mr. Worster.

Tea-pot, silver gilt, representing the cultivation and preparation of tea. Chased silver sugar-basin, representing a West India sugar plantation, and cream-ewer, with an English farmyard. Gothic pattern silver tea-pot.

Child's mug, in silver gilt, with Wilkie's "Blind-man's buff;" designed and chased by Mr. T. Edwards. Another, with scrolls and flowers; designed by Mr. Percy.

Silver spoons of antique design. Strawberry pattern spoon and fork, in silver. Silver spoons in the style of Francis I., Elizabeth, &c. Child's knife, fork, and spoon, with rose, thistle, and shamrock, and heads of the Queen and Prince Albert, silver gilt.

Sugar-ladle, the handle a lily with a fairy emerging from the flower, silver gilt. Cream-ladle. Tea-caddy spoon, from the tea-plant. Sugar-ladle, sugar-cane handle, and shell for bowl. Variety of fancy silver salt-spoons,

with busts and heads of the Duke of Wellington, Nelson, Shakspeare, &c.

Knives, forks, and spoons, in cases, engraved in the Tudor and arabesque styles. Fish-carvers, handles richly chased. Salt-cellars, of various new designs. Pepper-caster, with pepper-plant. Muffineer, with sea-weed and shell in silver.

95 MATTHEWS, EDWARD, 46 *Berwick Street, Soho*—
Designer and Manufacturer.

Heraldic design, in which are comprised the various royal arms and coronets since the Conquest, engraved on different metals, and emblazoned with sealing wax in the proper colours.

96 ROBINSON, WILLIAM, 70 *Wynnyatt Street, Clerkenwell*
—Manufacturer and Patentee.

Gilt clock-case, constructed of electrotype deposited plates; the gilding effected by the same patent process. Smaller case, made with deposited plates, but with the engraved lines in relief.

Electro-plated tea-caddy and inkstand.

Smaller articles showing the uses to which electrotype may be applied in manufactures, apart from its uses in the fine arts.

[Plates of copper, when deposited by the electrotype process on a smooth plate of another metal, present a very perfect surface, and if the voltaic action is carefully regulated, the metal is very hard and tough; if too rapid, it is liable to become brittle, from assuming a semi-crystalline structure. The electro-gilding in these examples, is readily effected by employing solutions of the oxide of gold in the cyanide or the ferro-cyanide of potassium.—R. H.]

97 HUNT & ROSKELL (late STORR & MORTIMER), 156
*New Bond Street; Manufactory, 26 Harrison Street,
Graf's Inn Road*—Inventors, Designers, and Manufacturers.

1. Centre ornament and plateau, showing the application of silver to sculpture and decoration. The ornament is adapted as a stand for flowers by day, and as a candelabrum by night; and with these objects the various groups are selected to agree in subject.

On each quarter of the plateau are groups representing the Seasons. Flora attended by her Nymphs playing with flowers, and a lamb personifying Spring. Zephyrs bearing on their shoulders a female figure, crowned with wheat and carrying the sickle, representing Summer. Autumn is typified by the figures of Silenus, Bacchus, and Pomona. Winter, by the aged Saturnus, who, seated on a leafless tree, spreads his mantle over shivering nature; on his left is a figure representing Storms and Tempests, accompanied by wolves. Beneath the groups are the signs of the Zodiac.

On the foot of the centre ornament are figures representing the Quarters of the World, each being accompanied by appropriate animals.

The alto-relievo around the column represents Day and Night, attended by the Hours; and around the stem which supports the vase are four figures representing the Elements.

The whole is decorated with ornaments of the cinquecento period.—Designed and modelled by Alfred Brown, in the manufactory of the exhibitors.

The accompanying Plate represents this plateau.

2. A shield, embossed and chased in silver and iron, dedicated to Shakspeare, Milton, and Newton.

Shakspeare is represented seated in a vessel of immortality floating on the river of life, attended by Apollo, the god of Poetry, and Minerva, the goddess of Wisdom, who points out to him the various vices of humanity expressed by figures tormented by monsters. Genii of Poetry support tablets on which are inserted some of his finest writings. An eagle ready to soar indicates the lofty flight of his genius. On the side of the vessel is illustrated the seven ages of man. Three

floating Syrens repeat his poems; one, bearing the insignia of Folly, tells of Shakspeare's power of satire; Cupid, seated on a dolphin, illustrates the power of love.

The subjects on the iron border are from Hamlet:—His vision of the ghost of his father; his grief at the death of Ophelia; his vengeance and death.

Milton is represented dictating to his daughter his poem of Paradise Lost, inspired by Religion and Poetry, represented by two figures, one holding a torch and the other the lyre. Crouched behind a shield is Satan—

“Horror and doubt distract

His troubled thoughts, and from the bottom stir
The hell within him.”

Beneath the boughs of the forbidden tree is shown our first parents' disobedience, when

“From the bough she gave him of
That fair enticing fruit with liberal hand.”

Coiling around the stem is seen

“The enemy of mankind, enclosed
In serpent, inmate bad!”

Among the branches is the Genius of Evil. A group of Angels is represented flying towards Eden. On the border is represented the battle between Abdiel and Satan. The angel Raphael cautioning our first parents against their enemy; and their expulsion from the Garden.

The third medallion is devoted to Newton, who is represented reclining on a globe, contemplating the wonders of the heavens. Behind him are figures of Time, Truth, and Wisdom, who rebuke two crouching figures, typical of Ignorance and Superstition. On the right is a figure of Earth instructing her children, who are identified with Europe, Asia, Africa, and America. In faint relief above is shown the system of attraction which he propounded—a figure represents the Sun, around which the planets pursue their course.

On the border is represented the accident which led Newton to the contemplation and discovery of gravitation, and the incident which awakened his mind to the prism. Between, is Genius in a chariot tracking space, indicative of his comprehensive mind. Surmounting the medallions in the centre of the shield is a figure, the Genius of Arts and Sciences.—Antoine Vechte, artist, in the manufactory of the exhibitors.

3. A vase, of Etruscan form, embossed from thin sheets of silver in the highest and lowest possible relief. The subject, which is treated in the style of Michael Angelo, is the destruction of the Titans by Jupiter, who made war upon them for having imprisoned his father Saturn. The giants, sons of Cœlus and Terra, seeking to revenge the death of the Titans, made war on the gods, heaped rock upon rock, mountain on mountain, “Ossa on Pelion piled,” in order to reach heaven. Jupiter routed the foes, who were crushed under rocks and mountains. On the summit of the cover is Jupiter, who, with stern and angry looks, grasps thunderbolts, which he hurls on the presumptuous Titans below. Bordering the cover is the zodiacal circle in low relief. On the body of the vase, on each side, are groups of giants, some climbing upwards, some crushed by the rocks hurled by mighty Jove. Supported by the handles of the vase, two bold presumptuous giants stand out in full relief, vainly menacing the father of gods and men. On the foot are fallen distorted figures, representing Vice and Presumption, writhing in the agonies of death. On the neck of the vase, in low relief, are two figures representing Time and Fate, the former with his scythe, the latter grasping serpents. Among the representations in low relief may be recognised Satyrs and Bacchanals, in bowers of vine; Neptune in his chariot, drawn by sea-horses, hurling thunderbolts at the giants, who cast rocks at him; flies and grotesque insects writhe in a spider's web, alluding to the fate of Arachne. Below one of the handles is Pan, beneath the other a skeleton. Crocodiles, winged serpents, fiery dragons, and other fabulous monsters of sea and land, wage war with one another.—Antoine Vechte, artist.

4. A testimonial, in silver, presented to Sir Moses Montefiore. The sphinxes are indicative of the captivity



JARVIS.



JARVIS



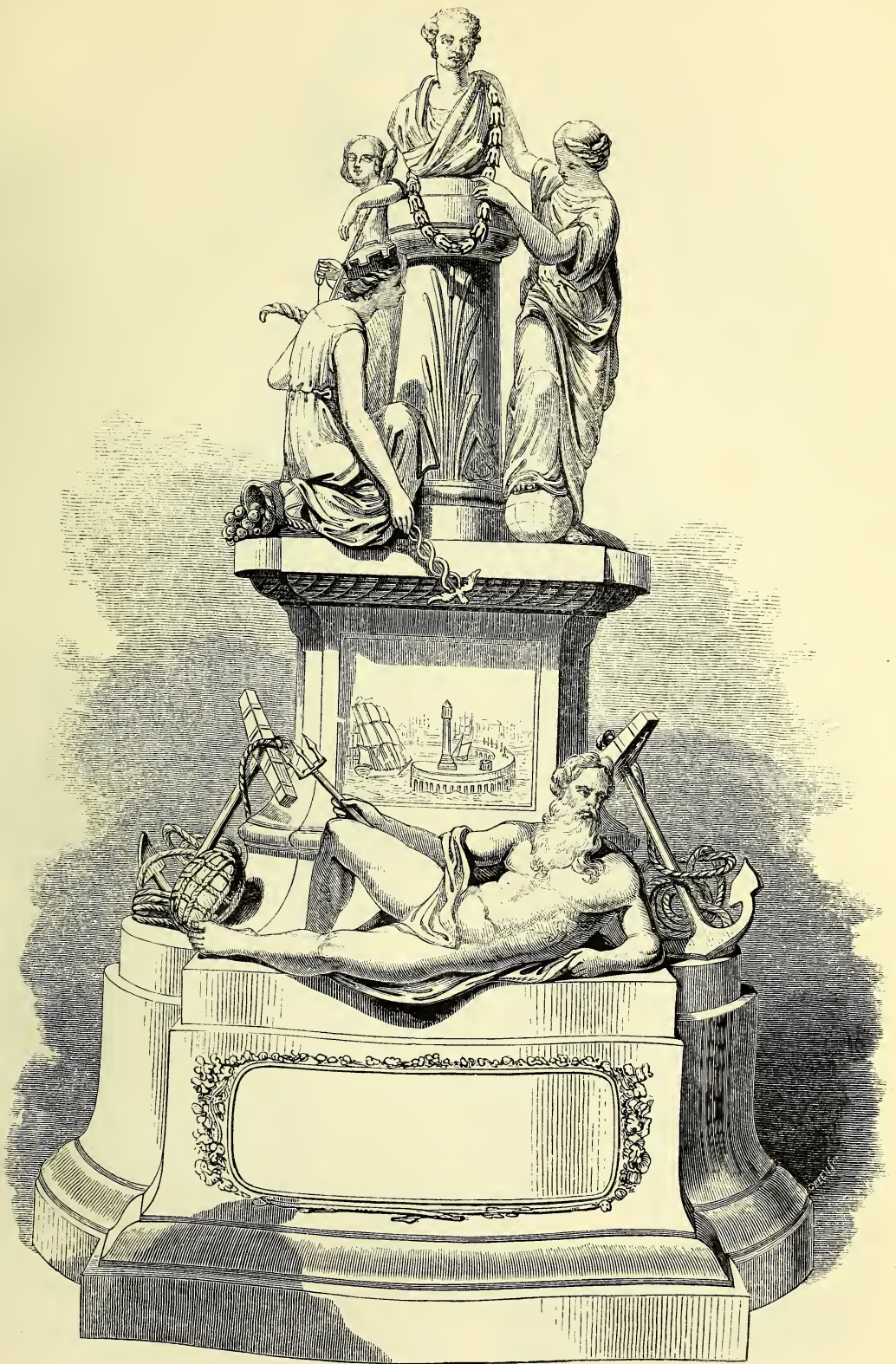

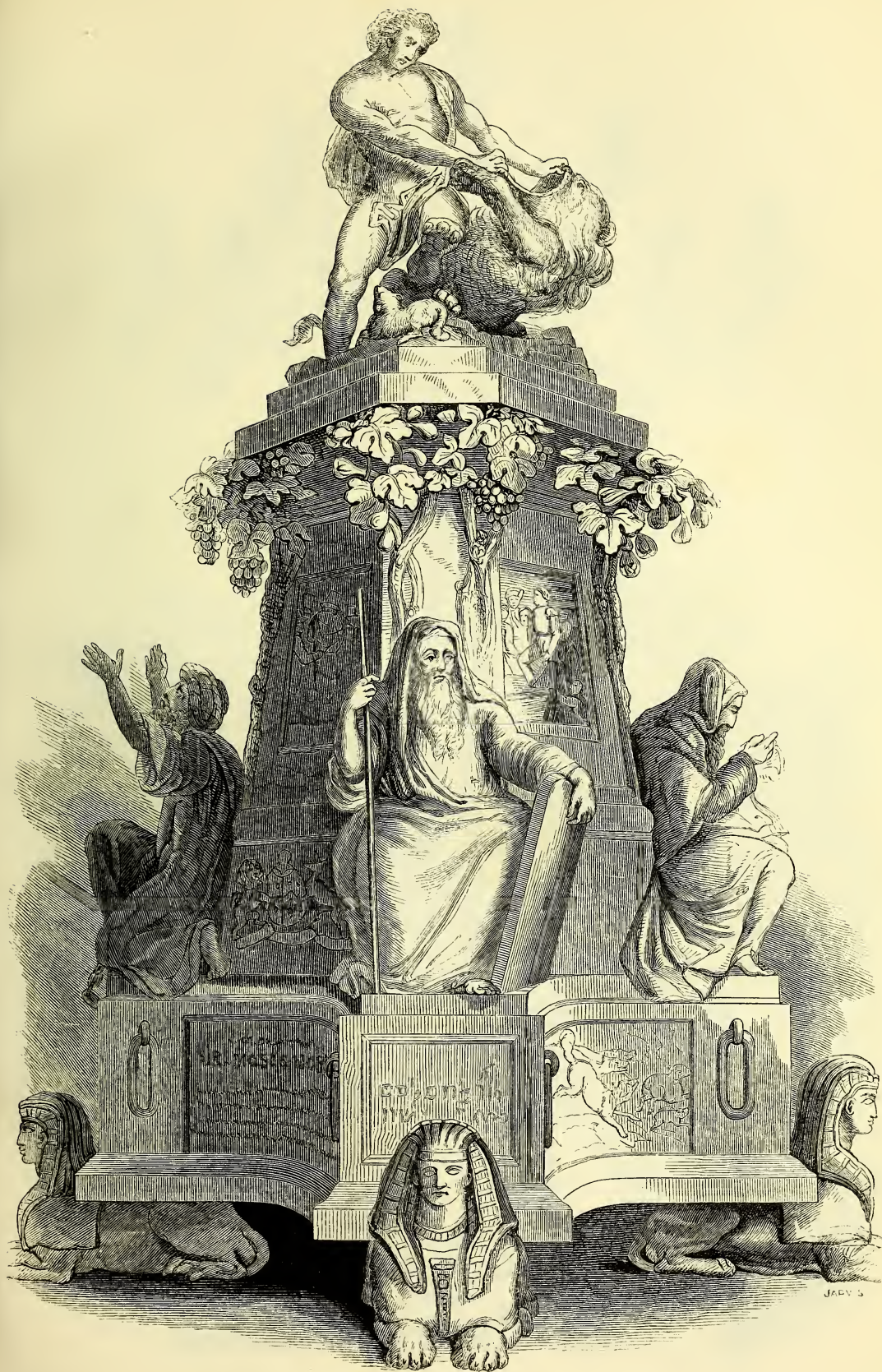

J. H. S.

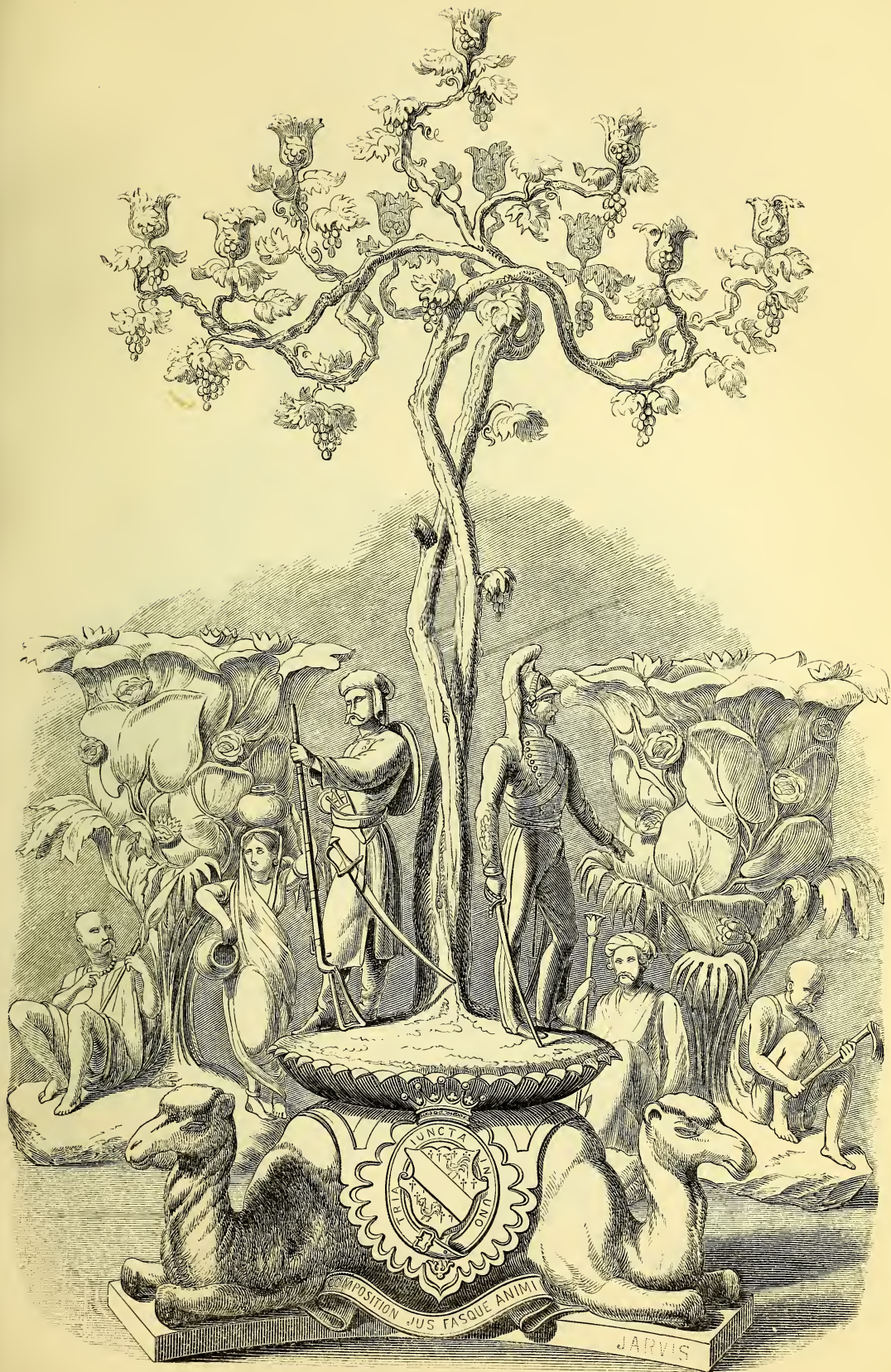





JARVIS.

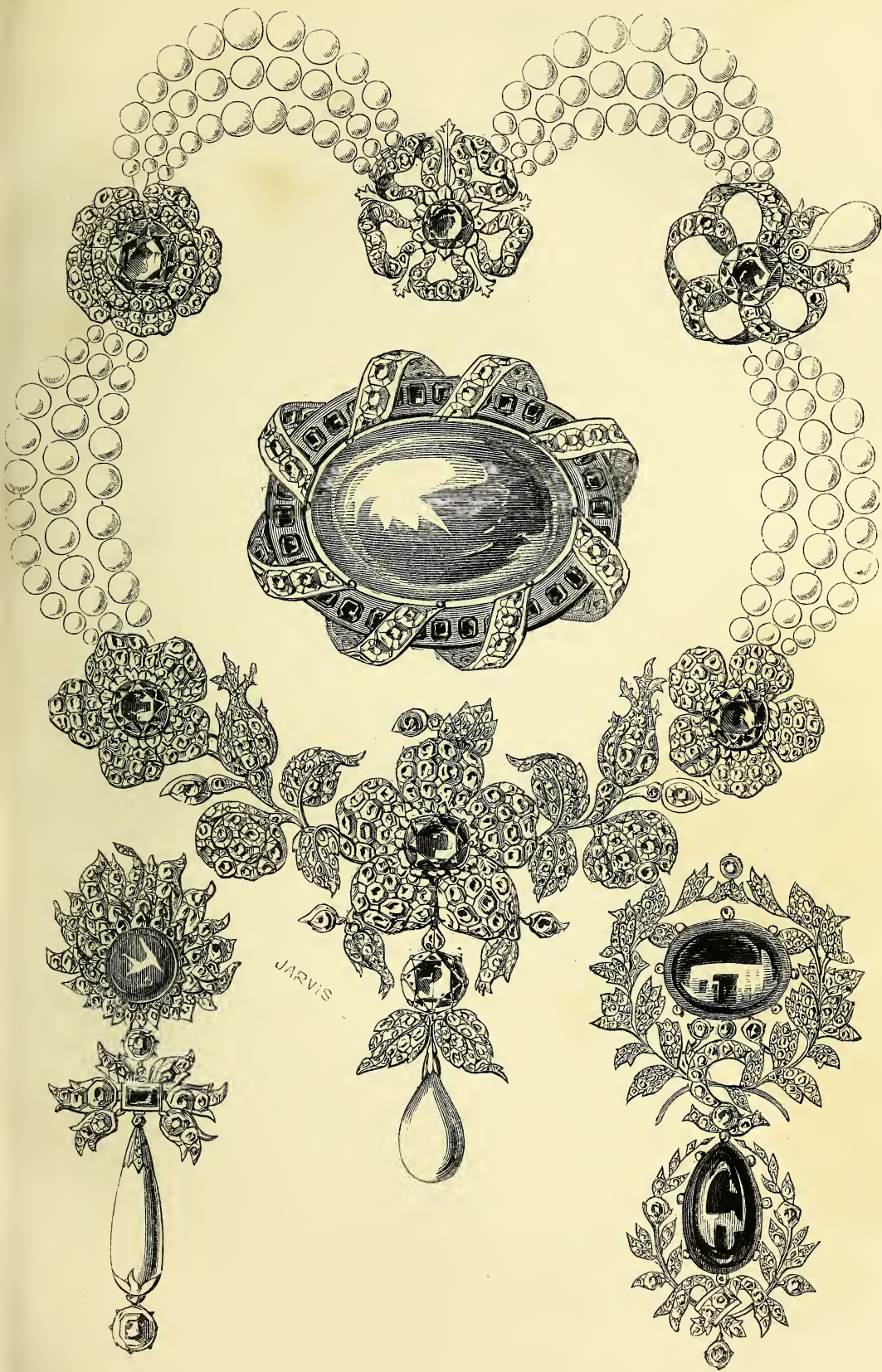

of Israel in Egypt. The figures are, Moses and Ezra, the great deliverers of their people; a Jew of Damascus, loaded with chains, and a released Jew. Under each is an appropriate text in Hebrew, the vine and fig-tree overshadowing. The group on the summit represents David rescuing the lamb from the jaws of the lion. The bassi-relievi represent the crossing of the Red Sea, and the destruction of Pharaoh's host. Lawless violence in the world typified by wolves devouring the flocks. Sir Moses and Lady Montefiore landing at Alexandria. Sir Moses obtaining the firman from the sultan. The persecuted Jews of Damascus returning thanks for their deliverance; and Sir Moses, after his return, attending the thanksgiving in the synagogue. Designed by Sir G. Hayter. This testimonial is represented in the accompanying Plate 55.

Portions of a service of plate presented to the Earl of Ellenborough in India:—

5. Grand centre, Asia crowning Britannia, on a pedestal of Indian architecture, with palm-trees at the angles. Bassi-relievi of the treaty of Nankin, and views of Calcutta, Cabul, and Canton. Figures of Afghan and Chinese captives, and a British sepoy. The whole supported by recumbent elephants. This grand centre is represented in the Plate 45.

6, 7. Two candelabra. Stems and branches composed of vine on a base of Indian architecture. Figures of a British grenadier, European officer of native infantry, foot-artillery soldier, horse-artillery man, native light-cavalry trooper, and a trooper of the irregular horse. The bases are supported by recumbent camels. One of these candelabra is represented in the Plate 97.

8, 9. Two ornaments for the end of the table; one representing the personification of the river Ganges, reclining under a cotton-tree with a rhinoceros; the other, of the river Indus, reclining under a plantain-tree with a camel. The bases are of Indian architecture, supported by Brahmin bulls. One of these ornaments is represented in the accompanying Plate 58, in the back ground. In front are the lotus icepails 10—13.

10—13. Four icepails, formed of the lotus, supported by other Indian plants. Figures of a cotton-spinner, a water-carrier, and a moonshee; a chobdar, a ryot, and a nautch-girl; a banghy badar, a hubble-bubble smoker, and a faquir; a zemindar, a Hindoo female washing her hair, and a bheestie, or male water-carrier.

14—17. Four dessert stands: Indian figures and plants.

A Hindoo girl depositing her lamp on the waters of the Ganges, under a mango-tree (*Mangifera Indica*).

A Hindoo fruit-seller under a catalpa-tree (*Syringafolia*).

A Hindoo girl plucking the sacred moon-plant (*Sarcostema viminialis*) under the sacred fig-tree (*Ficus religiosa*).

A Hindoo flower-seller under a banyan-tree (*Ficus Indica*). Designed by Mr. Frank Howard. Modelled by Mr. Alfred Brown, of the exhibitors' manufactory.

18. A cup, in silver, presented to Charles Kemble, Esq., on his retirement from the stage. The frieze represents the Seven Ages; the figure on the summit, Mr. Kemble as Hamlet. This was the last work in silver superintended by the late Sir Francis Chantrey.

19. Testimonial, presented to the Marquis of Tweeddale. Subject of group, the origin of his noble family; a countryman, named Hay, with his two sons, leading the Scots to the defeat of the Danes, who had invaded their country, A.D. 980. *Vide* Buchanan's History of Scotland. Designed and modelled by Mr. Alfred Brown, at the exhibitors' manufactory. This testimonial is represented in the accompanying Plate 115.

20. A group, in silver, representing the meeting of Francis I. and Henry VIII. on the Field of the Cloth of Gold. The property of His Grace the Duke of Norfolk.

21. A testimonial, presented by Wilbraham Egerton, Esq., to the 43rd Light Infantry.

22. A testimonial, presented to J. B. Neilson, Esq., for his invention for smelting iron, &c., by means of "the hot blast." The figures represent Minerva; Science crowned by Britannia. Around the base are Vulcan, Æolus, and Prometheus. Designed and modelled under the superintendence of E. H. Baily, Esq., R.A.

23. A group, representing Robert Bruce, king of Scotland, attacked by assassins in the mountain pass. *Vide* Scott's "Lord of the Isles." Designed by Mr. Frank Howard.

24. A testimonial, presented to B. Lumley, Esq., of Her Majesty's Theatre. Figures representing Melpomene, Thalia, Terpsichore, and Euterpe. Designed and modelled by Mr. Alfred Brown, at the exhibitors' manufactory.

25. A candelabrum, Louis XIVth style. Subject, St. George and the Dragon. The property of H.R.H. the Duke of Nassau.

26—29. Four candelabra, with hunting subjects. The property of H.R.H. the Duke of Nassau.

30. A shield, in silver, representing the Battle of the Standard, after Leonardo da Vinci. The property of the Earl of Uxbridge. Designed and modelled under the superintendence of E. H. Baily, Esq.

31. A shield, in silver, representing the principal incidents in the life of Peter the Great. In the centre is Peter the Great triumphing over Ignorance, Vice, and Envy. The six compartments, divided by figures of Victory, represent Peter delivered from the insurrection of the Strelitz; Peter working as a shipwright in Deptford Dockyard; the foundation of the city of St. Petersburg; his clemency at the taking of Neva; Catherine and Peter at the Battle of Pruth; Peter crowning Catherine empress. This piece of plate was the prize given by the Emperor of Russia at the Ascot races, 1848. The property of Sir John Mill. Designed and modelled by Mr. Alfred Brown, at the exhibitors' manufactory.

32. The shield of Æneas, in copper, deposited by the galvanic process. *Vide* Æneid, book 8th:—

"But most admires the shield's mysterious mould."

Designed and modelled by the late W. Pitts.

33. The Portland or Barberini Vase, in silver.

34. A testimonial, presented to Sir George Cockburn. Four figures, representing Europe, Asia, Africa, and America; also, a sailor, a royal marine, an artillery-man, and a soldier of the 85th Regiment.

35. A group, in bronze: Alexander and Bucephalus.

36. An equestrian statuette of the Duke of Wellington, in bronze. Modelled by E. H. Baily, Esq., R.A.

37, 38. Two Indian female figures, in bronze.

39. A silver group: Mazeppa.

40. A group, in silver: Michael and Satan, after Flaxman. The property of the Earl of Chesterfield.

41—44. Four equestrian statuettes, in silver:—Joan of Arc; a cavalier; an Arab; a Hussar. The property of the Earl de Grey. Designed and modelled by Mr. Alfred Brown, at the exhibitors' manufactory.

45. The Goodwood Cup of 1849, of Elizabethan character, with three groups, representing tilting, hawking, and hunting. The property of the Earl of Derby.

46. The Doncaster cup of 1850. Subjects, Victory crowning the horse. Aiti-relievi, representing chariot-racing; racing with the torch; Italian and the modern race; groups of wild and domestic horses. The property of the Earl of Zetland.

47. A salver, in silver, partly gilt; Elizabethan style. The property of C. C. Martyn, Esq.

48, 49. A dish and tureen, to correspond. The property of C. C. Martyn, Esq. Designed by J. G. Craze, Esq.

50. The Hartlepool testimonial, presented to R. W. Jackson, Esq. The figures represent Commerce, Science, and Industry, Neptune and Æolus. Bassi-relievi, representing the Hartlepool West Harbour and Docks. The bust is a portrait of the presentee. This testimonial is represented in the Plate 136.

51—55. Five candelabra, in silver, Louis XVth style, with bacchanalian groups.

56, 57. Two end ornaments. Subjects, Pomona and Flora.

58, 59. A silver-gilt vase and salver, style of the 16th century, set with antique gems.

60, 61. Two tazzas, to correspond.

62. A casket, to correspond. The property of the Princess Basil Kotschoubey.

63—81. A vase in silver, style of the cinque-cento period, enamelled and gilt. Looking-glass and stand. Testimonial, presented to Mr. Williamson, with Indian figures and animals. Two vases, of Etruscan form. An ice pail. Claret jug. Ornamented and plain tea sets. Gilt tea set. Coffee pot; tea pot; sugar basin; slop basin; cream ewer. Cake basket. Salts. Entrée dish and cover. The Emperor's prize, Ascot, 1847. The Goodwood cup, 1848. Group in bronze. A shield in silver, with portraits of Field-Marshal the Duke of Wellington, the Duke of Richmond, the Marquis of Anglesey, &c., presented to the Goodwood races by the late Lord George Bentinck, now the property of Colonel Peel. Two equestrian statuettes of the Emperor Napoleon, and Field Marshal the Duke of Wellington; executed for his Grace in silver gilt, from models by the Count D'Orsay. The hand of the Infanta Josephine of Spain, in silver. Several ornaments, specimens of workmanship, in silver. Specimens of various patterns of spoons and forks, &c.

Large and fine collection of precious stones, 198 in number, from that of the late H. P. Hope, Esq.

Models of brilliants, and specimens of seal engraving.

Jewellery.

Diamond bouquet, being a specimen of the art of diamond setting. The flowers: the anemone, rose, carnation, &c., are modelled from nature. This ornament divides into seven different sprigs, each complete in design, and the complicated flowers, by mechanical contrivances, separate for the purpose of effectual cleaning. It contains nearly 6,000 diamonds, the largest of which weighs upwards of 10 carats, and some of the smallest in the stamens of the flowers would not exceed 1000th part of a carat. This bouquet is represented in the accompanying Plate.

Enamelled portrait of Her Majesty, on gold, by J. Haslem, after F. Winterhalter, painted by His Royal Highness Prince Albert's permission, from a picture in his possession. The portrait is surrounded with a wreath of oak, enamelled on fine gold, set with pearls and diamonds.

Ornament for the head, composed of branch coral, connected by leaves of enamel and gold, enriched with diamonds.

Several brooches and other ornaments in enamelled gold, set with diamonds. The flowers modelled from nature.

Enamelled portrait of Her Majesty, on gold, by J. Haslem, set as a bracelet, with carbuncles and diamonds. Specimens of ear-rings, in emeralds, diamonds, carbuncles, &c., after the marbles from Nineveh.

Enamelled portrait of Shakespeare, on gold, by W. Essex, from the portrait in the possession of the Earl of Ellesmere, set as a ring, with diamonds.

Enamelled miniature portrait of the late Sir Robert Peel, by W. Essex, set as a ring.

Several ornaments, specimens of workmanship in diamonds and other precious stones, &c.

Watches, &c.

Fine gold watch, with improved detached lever escapement, chronometer balance, isochronal spring, and dial showing the phases of the moon, thermometer with two different scales, days of the month, hours, minutes, and seconds' hands; the one underneath the other may be stopped at pleasure for any length of time, without interfering with the going of the watch, by moving a small nib on the side of the case, and when released by the same means, flies immediately under the other hand, and assumes the appearance of one hand only. This arrangement is very useful for scientific purposes. On the back the hours are enamelled in blue, and it also carries a *tac* hand for the purpose of feeling the time at night.

Fine gold chronometer, with tourbillon escapement, dial showing hours, minutes, and seconds, and carrying a thermometer with two different scales.

Flat gold watch, with duplex escapement, chronometer balance, isochronal spring, silver dial, showing hours, minutes, days of the month, and thermometer. It is so

constructed as not to require joints to the case; it sets and regulates at the side.

Gold watch, with flowers painted on blue enamel, detached lever escapement, chronometer balance, engraved gold dial.

Highly-finished eight-day marine chronometer, in rose-wood case.

Eight-day striking clock, engraved gilt case, chronometer escapement, and day of the month calendar.

Eight-day striking clock, engraved gilt case, with aneroid barometer and thermometer, detached lever escapement.

Large oval eight-day time-piece, engraved gilt case, with aneroid barometer, day of the month calendar, and thermometer, detached lever escapement, compensation balance.

Small oval eight-day carriage time-piece, engraved gilt case, with thermometer, detached lever escapement.

Square-shaped eight-day carriage time-piece, engraved gilt case, with day of the month calendar, detached lever escapement. The flatness of this clock renders it peculiarly adapted to the carriage.

Oval eight-day carriage time-piece, engraved gilt case, with perpetual day of the month calendar, detached lever escapement.

Clocks and watches of various construction.

Specimens of various precious stones, in the rough and wrought state; also, pearls, in the fish, attached to the shell, &c., 46 in number.

98 GARRARD, R. and S., & Co., *Panton Street, Haymarket, Goldsmiths to the Queen*—Manufacturers.

1. Cup, in the form of a nautilus shell, floating on a wave; on the upper part of which is seated a figure of Neptune attended by nymphs, and preceded by sea-horses.

2. Tankard of ancient design, surrounded by a group, St. George and the Dragon.

3. Flagon, with side chains, with group representing Arabs of the desert hunting a lioness.

4. Ewer, in the style of the sixteenth century. The knight's challenge.

5. Kettle and stand, coffee-pot, tea-pot, sugar-basin, cream-ewer, and hot-milk ewer, Persian drop pattern.

6. Tea or coffee salver.

7. Table-candlestick in the style of Queen Anne, with group of boys supporting the nozzle.

8. Table candlestick, in the same style, with flat masks on shaft.

9. The same, hexagonal shape.

10. Table-candlestick, with scrolls, flowers, and boys, in style of Louis XIV.

11. Candelabrum, with scroll and fruit ornament, and six twisted foliage branches and centre.

12. Group,—Arabs of the desert tracking travellers by their footmarks in the sand.

13. Group,—The Arab disdains all inducements of the Turkish merchant to barter for his mare and foal.

14. Candelabrum, with six arms, in the renaissance style.

15. Ewer, in the style of Cellini.

16. Tea and coffee service, consisting of tea-pot, coffee-pot, sugar-basin, and cream-ewer.

17. Twenty-six inch flower border tea and coffee salver.

18. Ewer—Perseus and Andromeda.

19. Boy, in kneeling position, supporting basket of flowers.

20. Group,—“The Lasso.”

21. Female dancing figures, with baskets for flowers.

22. Ewer. The group represents Sioux Indians hunting the bison in the prairies of North America.

23. Tea and coffee service, consisting of tea-pot, coffee-pot, sugar-basin, cream-ewer, and high ewer, engraved Dresden pattern.

24. Cup and cover in the style of sixteenth century.

25. Candelabrum, with three branches, in the style of Queen Anne.

26. Group,—Lucy Ashton at the death of the Stag.

27. Group,—Hawking Party.

28. Tea and coffee service, consisting of kettle and



139. EMPEROR OF RUSSIA'S EWER—REPRESENTING THE LABOURS OF HERCULES, AND TWO FRUIT BASKETS, IN SILVER. R. AND S. GARRARD AND CO.

stand, silver tea-pot, coffee-pot, sugar-basin, and cream-ewer, Princess Royal pattern.

29. Candelabrum, with four scroll branches, and group of boys gathering grapes.

30. Ewer, in the florid style of Louis XIV., with hounds and foxes.

31. Centre-piece,—John, Duke of Marlborough, on the battle-field of Blenheim, A.D., 1704.

32. An agricultural testimonial from the tenantry to the landlord.

33. Candelabrum in the peculiar style of the early Arabs. The group represents Saladin and Sir Kenneth halting at the fountain (from Scott's "Talisman").

34. Ewer. The principal subject of this piece of plate is a group, illustrative of the eighth labour of Hercules. On other parts of the vase are emblems of the seven previous labours of Hercules; on the body, the heads and skins of the Cleonian lion, the Erymanthian boar, the Menalean stag, and the Cretan bull; on the neck the Stymphalides. The handle is formed of the Lernean hydra; the foot represents the cleansing of the Augean stables. This ewer is represented in the accompanying Plate 139.

35. Group,—Battle of Lansdown Hill near Bath, A.D. 1643.

36. Equestrian statue of the Duke of Wellington.

37. Lump of native gold, from California, weight, 18 lbs.

38–41. Seals:—The Young Sailor; the Young Highland Chief; Sikh Chief; and Highland Chief.

42. Model of Lindfield Church, Sussex; testimonial from the parishioners to their late pastor.

51. Candelabrum—Thomas the Rhymer and the Fairy Queen.

52. A suite of ornaments for the table, in the style of Watteau, consisting of a centre-piece for lights, with a courtly pic-nic party amusing themselves with music, while their attendants prepare the repast. Four fruit baskets, with groups of figures in various occupations, and with attributes denoting the Seasons. Two fruit baskets in corresponding style, with figures occupied in sylvan pastimes. One of these fruit baskets is represented in the Plate 139.

53–56. Spring. Summer. Autumn. Winter.

57, 58. Dancing. Archery.

59. Soup tureen, with marine figure handles, and supported by dolphins.

60–63. Four entrée dishes and covers in various styles.

64. Cup. Richard Cœur de Lion at Ascalon, A.D. 1191.

65. Cup, with design from a monument to John Selwyn, in the chancel of the church at Walton-upon-Thames.

66. Ewer, with group of stags and vine ornament.

67. Ewer,—Battle of the Centaurs.

68. The Great Railway Salver, or Brassey testimonial: a shield bearing in the centre the arms and motto of Thomas Brassey, Esq., with inscription; in the compartments are enamel portraits of Messrs. G. Stephenson, Locke, W. Cubitt, R. Stephenson, Errington, Brust, J. Cubitt, Dockray, Rendall, Bidder, and Brunel. A view of a principal work of each is represented above the portrait of the designer.

69. Group,—Gen. Lord Seaton in Canada; the family of a wounded Canadian prisoner supplicating on his behalf.

70. Group,—“The Earth-stopper.”

71. Group, Don Quixote: “Sancho Panza introducing the Duchess as Princess Micomicona.”

72. Group of St. George and the Dragon.

73. Ornamental centre-piece for a table, with portraits of some of the Queen's favourite dogs.

74. Basket for sugar, supported by boys. This is represented in the Plate.

75, 76. Salts: high bossed pattern, and tripod.

77–80. Dessert dishes: on foot, renaissance, and partly gilt; shell and pierced, gilt; and Elizabethan pattern, part gilt.

81. Basin, supported by mermaid, for sugar.

82. Mounted decanter and stand: subject,—Triumph of Neptune.

83. Small inkstand, style Louis XIV.

Jewellery:—

1. Suite of very fine opals and brilliants, consisting of necklace, stomacher, ear-rings, bracelet, and pin.

[The opal is a native of Saxony, Ireland, Hungary, and Central America. The luminous colours are supposed to be caused by layers of air or other fluids enclosed in its fissures (Hang.). When heated it bursts.—W. D. L. R.]

2. Suite of fine sapphires, pearls, and brilliants, viz., necklace, brooch, and bracelet.

[The sapphire ranks after the diamond in hardness and value. It is found in Ceylon, Pegu, and Bohemia.—W. D. L. R.]

3. Suite of rubies and brilliants, consisting of necklace, brooch, and bracelet.

4. Brilliant tiara, ornamented with fine oriental pearl drops and boutons, and four brilliant drops of the purest water.

5. Bracelet representing water-nymphs bringing a pearl from the deep, the shell ornamented with emeralds and brilliants, the gold work chased.

6. Bracelet of Gothic design, with angels holding a ruby and pearl, enamelled and chased.

7. Pendant of ancient design, with figures ornamented with rubies, brilliants, and pearls.

8. Brooch of ancient design, ornamented with rubies, brilliants, and pearls.

9. Bracelet of fine emeralds and brilliants.

10. Bracelet, with natural pink topaz, set with brilliants and enamelled.

[The topaz is a native of Siberia, Saxony, South America, &c.; that called oriental is a variety of sapphire. The pink naturally are rare, that colour being mostly given to the stones by heat.—W. D. L. R.]

11. Bracelet, with a plum-coloured pearl bouton, set with brilliants.

12. Pendant of brilliants, with turquoise centre.

13. Pendant of brilliants, with fine pink brilliant centre and drop.

14. Brooch of fine oriental onyx, set with brilliants.

[The layers of different colours possessed by the onyx have, from the most ancient times, rendered it precious for engraving in intaglio or relievo. Much of what is known of ancient art is due to the onyx, in which miniatures of the works of the great masters were executed, as well as original designs.—W. D. L. R.]

15. Gold watch with enamelled back, set with diamonds.

16. Set of three fine oriental pearl studs, in enamelled settings, with diamonds.

17. Bracelet in carved gold, with emerald and brilliant centre.

18. Bracelet in polished gold, with ruby and brilliant circular centre—from the Nineveh sculptures.

19. Bracelet in coloured gold, with large carbuncle and brilliant centre (oriental design).

20. Stomacher brooch of brilliants and fine oriental pearls.

21. Brilliant brooch with emerald centre, and pair of fine emerald tassel drops.

22. Pendant of brilliants, with pink topaz, centre, and pearl drop.

23. Pendant of opals, rubies, and brilliants, and solid opal drop.

24, 25. Brooches of brilliants and pink pearls.

26–29. Fly brooches: ruby, emerald, and brilliants; emerald, sapphire, opals, and brilliants; pearl, sapphire, tourmalin, and brilliants; jacynth, emerald, ruby, and brilliants.

30–35. Rings: rubies and brilliants; fine oriental pearl, set with rose diamonds; cabuchon, sapphire, and brilliants; cabuchon, emerald, and brilliants; fine turquoise and brilliants; and fine ruby and brilliants.

99 FORRER, ANTONI, 136 Regent Street—Proprietor.

Table with glass case, containing a variety of jewellery ornaments worked in hair and gold; consisting of bracelets,

brooches, rings, chains, &c., and having a large centre top. Ornamental frame, containing the miniatures of the Queen, H.R.H. Prince Albert, and the Royal Family; mounted in hair and gold. Designed and executed by the exhibitor.

[These works tend to show the amount of skill, taste, design, and variety, that workings in hair are susceptible of. It has been a class of manufacture of mediocre perfection hitherto; but from the ready weaving of the material into many forms, and its graceful union with gold, as well as its being peculiarly adapted for souvenirs, it may well claim to rank higher in artistic manufactures.]

100 WIDDOWSON & VEALE, 73 Strand—Manufacturers.

In silver, a centre-piece for the table:—A plateau with candelabra and dessert stands ornamented with numerous figures and armorial bearings of Lord Londesborough. Chased sideboard dish for rosewater.

Equestrian statuette of the Duke of Wellington.

Sacramental flagon and chalice, embossed with illustrative groups.

Claret-jug of antique form, with wreath of vine.

Breakfast service; consisting of coffee-pot, tea-pot, sugar-basin, and cream-jug of Etruscan form, ornamented with illustrations of the Iliad after Flaxman.

Inkstand, with figure. New grape-nippers.

Spoons and forks and a set of three wine-tables, of the Tudor period.

Bracelet of emerald and brilliants. Necklace pendants of the Elizabethan era, set with precious stones. A case of rings.

101 GRAY, JOHN, 5 Billiter Square—Manufacturer.

Series, illustrative of the manufacture of plated articles from metal plated in the ingot.

Ingot of copper, with the silver tied thereto, preparatory to their being united by fire.

Ingot of white metal, and ingot of copper after the silver has been united to them by heat only, without solder, or any other intervening substance.

Sheet of plated metal, rolled from the ingot.

Table dish made from the rolled metal, with silver mountings tied on, ready for soldering.

Steel dies, in which the silver mountings are struck, with mountings that have been struck therein.

Table dish in a finished state.

Waiter, that has been in use since 1801, made by the foregoing process.

A specimen waiter of the foregoing manufacture, as at present conducted.

[The ingot used in the manufacture of plated silver is not of pure copper, but consists of an alloy of that metal, in order to communicate to it the necessary rigidity. The ingot, with its superficial plate of silver tied on to its polished surface with wire, is heated in a furnace. The heat causes the union of the metals; and the ingot, after proper preparation, is fit for manufacture into various articles.—R. E.]

102 LAMBERT & RAWLINGS, Coventry Street—Proprietors.

Grand twelve-light candelabrum and dessert centre for the table, in silver; design, Britannia, in peaceful attitude, welcoming the representatives of the four quarters of the earth, with their various offerings and productions.

Large, partly gilt, silver wine flagon, chased with Gothic ine-leaves, &c.; another oak-chased.

Silver water-bottles, from the antique.

Pair of chased silver soup-tureens and stands, in the style of Louis Quatorze.

Ruby glass cups, mounted in silver gilt, after the antique.

Fancy centre salt-cellars: designs, Pegasus, Dolphin and Boy.

Fancy silver gilt inkstand, tessellated with malachite.

A pair of silver bottles with chains, from the antique.

Antique silver-gilt inkstand, in the Dresden style, with figures of Britannia, Commerce, and Plenty.

Pierced bread-basket, engraved with rose, shamrock, and thistle, and mounted with bunches of wheat, Indian corn, and wild flowers.

Chased knife, fork, and spoon, with figures—fish and game.

Pair of partly gilt dessert stands, copied from an antique stand of the fifteenth century.

Female figure supporting a basket.

Antique Italian pattern ewer, chased (fifteenth century).

Ruby glass tankard, mounted in silver gilt, from the antique.

Ruby and white enamel glass sugar-basin, with pierced silver-gilt mounting, after the antique.

Hot-water jug and cover; copy from the antique delf.

Partly silver-gilt stand, to hold six antique cups, for centre of table.

Old ball pattern, silver tea-kettle and stand, with coffee-pot, tea-pot, sugar-basin, and cream-ewer, *en suite*.

Octagon engraved silver coffee-pot, tea-pot, sugar-basin, and cream-ewer, *en suite*.

Ruby glass vases, moulded in the old style. Silver fruit stands with bacchanalian figures.

Chased antique pattern, silver-gilt flagon. Fine specimen of coral with malachite stand.

Antique pattern silver flagon and chalices. Gilt paten. Offertory plate. Chased silver paten.

103 ANGELL, GEORGE, 51 Compton Street, Clerkenwell—Manufacturer.

Large vase, in the Etruscan style, illustrative of the progress of civilization. The principal subject on one side is the invasion of England by the Romans; above it are allegorical figures, emblematical of the introduction of civilization to Great Britain. On the other side is the treaty of Penn with the Indians, with allegorical figures.

Candelabra, in eastern style, representing the attack of a boa constrictor on a lioness and cubs. Candelabra (acanthus), with figures of Truth, Justice, and Mercy.

Tea-tray, illustrative of the purposes of the Exhibition. The ship of all nations, commanded by Britannia, and steered by Father Thames, entering the Pool, attended by Neptune, and followed by Navigation and Commerce; above are figures representing the four quarters of the globe, with others of Justice, Fame, and History. Engraved medallions, in border, showing trading between the nations, steam navigation and machinery. Engraved and designed by Donalds and Son.

Trifle-stand, in the Italian style. Partly gilt engraved coffee-pot, tea-pot, sugar-basin, and cream-ewer. Partly gilt claret jug, Etruscan, and silver claret jug.

104 MARSHALL, EDMUND SMITH, 31 John Street, Tottenham Court Road—Manufacturer.

Gold-leaf for the use of gilders, bookbinders, japanners, writers, printers in gold, and others; also layers of gold. Gold-leaf for the use of dentists, gold lace manufacturers, and others.

Silver, copper, tin, zinc, lead, and tellurium; exhibiting an illustration of the malleability of the metals. Gold-beaters' skin, as used in the manufacture.

105 WATHERSTON & BROGDEN, 16 Henrietta Street, Covent Garden—Manufacturers.

Standard gold, enamelled, and jewelled vase, executed by the exhibitors, after a design by Mr. Alfred Brown. The group surmounting the cover represents the United Kingdom by the figures of Britannia, Scotia, and Hibernia. Britannia is in the centre, resting her hand on the trident; Hibernia is on her right; and Scotia on her left. Around the edge of the cup are four heads, symbolical of the

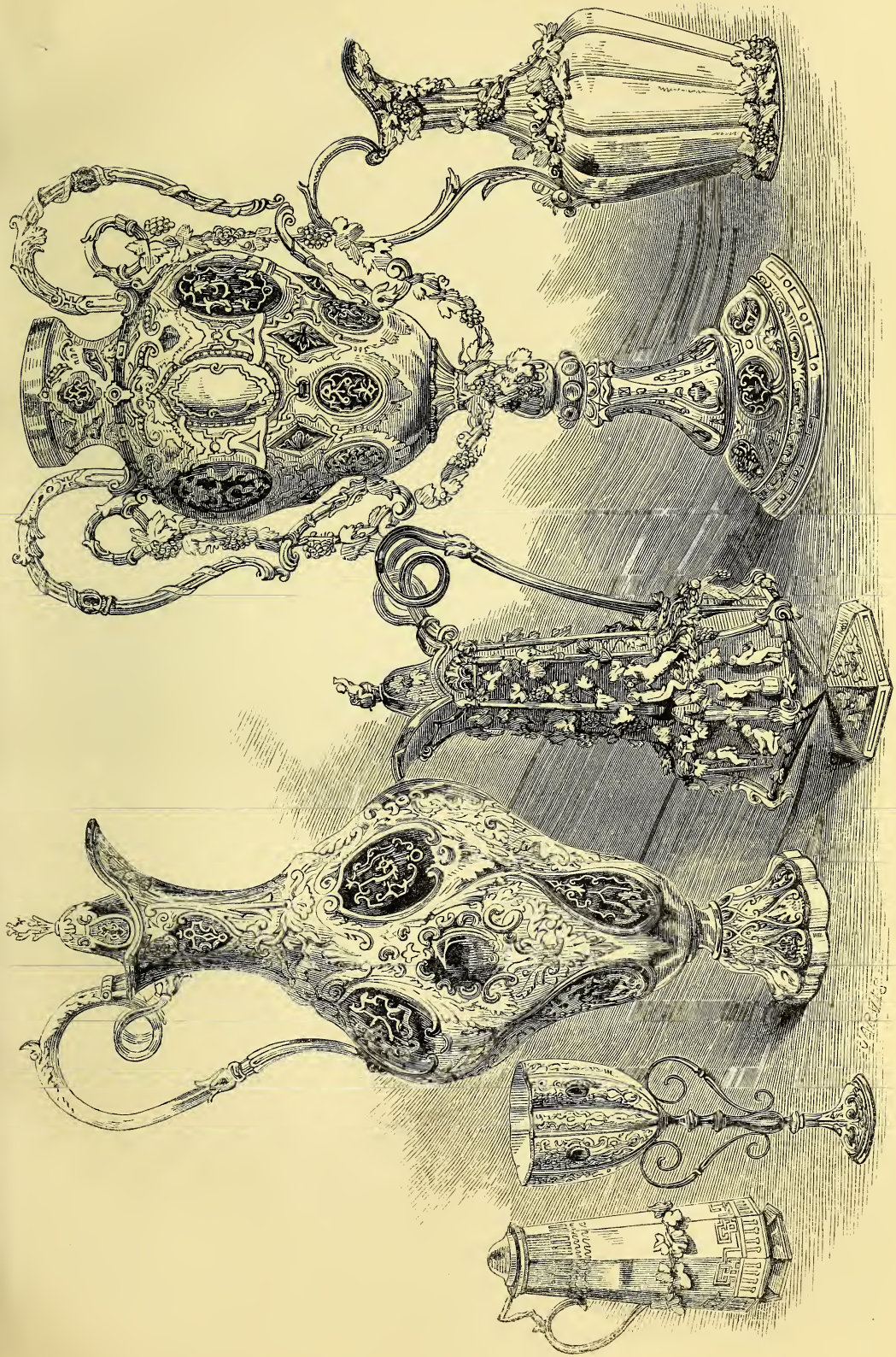

ENAMELLED AND SILVER FLAGONS, VASE, AND GOBLET. MR. ANGELL.



quarters of the globe. Below these are festoons of diamonds representing the rose, thistle, and shamrock.

Surrounding the body of the vase, are reliefs, representing Britons, Romans, Saxons, and Normans, with the landing of the Romans, and the battle of Hastings. Beneath, are two figures of fame descending with wreaths of laurel, crowning Nelson, Wellington, Milton, Shakspeare, Newton, and Watt, whose busts are introduced in concaves; while, on the lower part of the cup, are the figures of Truth, Prudence, Industry, and Fortitude, accompanied by their appropriate emblems. The vase weighs 95 ounces; is decorated with diamonds, pearls, rubies, carbuncles, sapphires, and emeralds, relieved by a cinque-cento ornamental enamel ground. This vase cost 2,000*l*.

Gold brooches, bracelets, necklaces, chains, seals, and rings.

106 **HOLT, JOSEPH**, 80 *Pratt Street, Camden Town*—
Manufacturer.

A variety of medallions. Specimens of modelling, chasing, and embossing.

107 **MOSLEY, RICHARD, & Co.**, 8 *Hatton Garden*—
Manufacturers.

Gold pens tipped with iridium, in various forms. Gold and silver pencil-cases, pen-holders, &c., of various kinds.

[Iridium is an extremely rare substance, generally found in combination with platinum as an alloy, from which state it is separated with difficulty. The name was derived from the remarkable play of colours exhibited by some of its soluble salts.—R. E.]

108 **FORREST, WILLIAM**, 54 *Strand*—Manufacturer.

Silver rose-water dish, partly gilt, designed, modelled, and chiselled by Wagner of Paris, being his last work.

109 **EADY, HENRY J.**, 26 *Red Lion Street, Clerkenwell*—
Designer and Manufacturer.

Set of chessmen, period A. D. 1520. Description of the meeting of Henry VIII. and Francis I. at the Field of the Cloth of Gold. The pieces are original models from portraits by Holbein, Titian, &c. of the leading characters assembled. The castles are designed from those of Ardres and Guize, the former of which was then in the possession of the English.

110 **SMITH, NICHOLSON, & Co.**, *Duke Street, Lincoln's Inn Fields*—Manufacturers.

Silver goods:—Candelabrum, with figures modelled by W. Beattie, sculptor, after a design by the Duchess of Sutherland.

Candelabrum ornament, a testimonial to W. Charles Macready, Esq., designed by B. Smith and C. Grant.

Candelabra of various designs.

Dessert service, designed from nature, with figures by J. S. Archer, sculptor.

Centre ornament, with group, by Beattie. Candlestick and branches. Table ornament. Tea-tray. Articles of Summerly's art manufacture.

Group,—The Well in the Desert. This is represented in the adjoining cut.

Electroplated goods:—Candelabrum. Dinner service, various patterns. Shield, executed for the Croxton Park races, 1851; centre by J. S. Archer.

Groups of miscellaneous articles.

A group of these articles, including a candelabrum and portions of a dessert service, is represented in Plate 117.

111 **ANGELL, JOSEPH**, 10 *Strand*—Designer and
Manufacturer.

Chased flower-stands, emblematical design, representing Europe, Asia, Africa, and America, each 16 inches high, gilt, and surmounted by a basket of flowers.

Coffee-pots, tea-pots, basins, and ewers, chased, engraved, enamelled, and gilt.



Messrs. Smith, Nicholson, & Co.'s Group—The Well in the Desert.

Group, representing Arab merchants halting in the desert.

Group, representing Sir Roger de Coverley having his fortune told by gipsies, and Addison standing behind, reclining against an old oak tree.

Caddy, engraved, gilt, and chased; another, engraved.

Claret jugs, chased, gilt, worked, and engraved; with illustrations and subjects.

Chased shields, with subjects—"The battle of Alexander and Darius," under medallions of the Queen and Prince Albert, four rivers, the Thames, the Nile, the Indus, and the Niagara; and on either side, Victory and Peace, Britain and History.

Salver, with engraved medallions, representing the labours of Hercules, &c.

Bread-baskets, and jewellery, consisting of bracelets, brooches, rings, &c., with new designs.

A group of these articles, comprising chased, gilt, and enamelled claret-jugs, flagons, goblet, &c., is represented in the Plate 104.

112 HANCOCK, CHARLES FREDERICK, 39 *Bruton Street, Berkeley Square*—Manufacturer.

Ebony inlaid silver table, of 45 inches diameter, on which is a silver vase; in pure Etruscan, after designs in the British Museum. This table is represented in the accompanying Plate 86.

A group in massive silver: subject "The entry of Queen Elizabeth on horseback into Kenilworth Castle," attended by Robert, Earl of Leicester, and a page,—two greyhounds in the foreground. Modelled by Baron Marchetti; the dogs by M'Carthy. It is mounted on a pedestal of the period, in fine old oak, with twelve marble columns, on the base of which is inlaid the favourite cipher of Queen Elizabeth, EAE; on each side are gilt panels on which is engraved the arms of the Queen; and above inlaid is the motto "Semper eadem," usually used by Her Majesty. At each end are likewise gilt panels engraved with the sword of state, the three crowns of England, Ireland, and France, and the well-known motto "Justitia." Executed at the manufactory of the exhibitor. This group is represented in the Plate 13.

Group in silver, mounted on an ebony pedestal, called "The Goodwood Cup," from the ancient legend of Robin Hood contending for the golden arrow.

Group in silver, mounted on a pedestal, taken from an old legend, representing Guy Earl of Warwick contending with a dragon.

Large cigar box, 24 inches by 17, in silver vine and lotus leaves, on ebony, after drawings by Eugene Lami: in the inside is a water-colour drawing by Harding, representing the rock of Gibraltar.

A silver vase, with open vine work, as a centre-piece for the table, on a rock base, with a royal crown and reversed cipher F, entwined on each side.

Small silver candelabrum, in the style of Louis XIV.

Bottle-carriage, on three wheels, in massive silver, with open vine work, leaves and bunches of grapes.

Dressing-case, of silver, partly gilt in the Etruscan style, with silver-gilt instruments, the box inlaid with silver in the same style, in Coromandel wood.

Tea service, consisting of a tea-pot, sugar-basin, and a cream-ewer, the sides ornamented with medallions and ornaments in the Florentine style of the 15th century.

Dessert-plate, in silver, border in vine leaves, with dessert-knife, fork, and spoon.

Gilt eight-day carriage clock; the movement by Cole, strikes the hours, half-hours, and quarters, and repeating also the minutes.

Three-bottle liquor frame, mounted in silver, with vine branches and leaves.

Specimen of chasing (*repoussé*), a dog's head.

Regimental "cravate de drapeau," embroidered in gold, on Pompadour velvet, with the arms of His Imperial Majesty the Emperor of Austria, of the Countess of Trapani, and the Prince Anatole Demidoff, designed and executed by James Holbech, 3 Vigo Street, Regent Street.

113 ATTENBOROUGH, RICHARD, 19 *Piccadilly*—Proprietor.

Silver centre for the table, to hold fruit, flowers, or sweatmeats, representing boys carrying baskets; with useful adjustments.

Card-tray of silver and enamel. A bachelor's tea set. Patterns of spoons and forks, of a new design. These are shown in the cut. Dishes, with border to match.

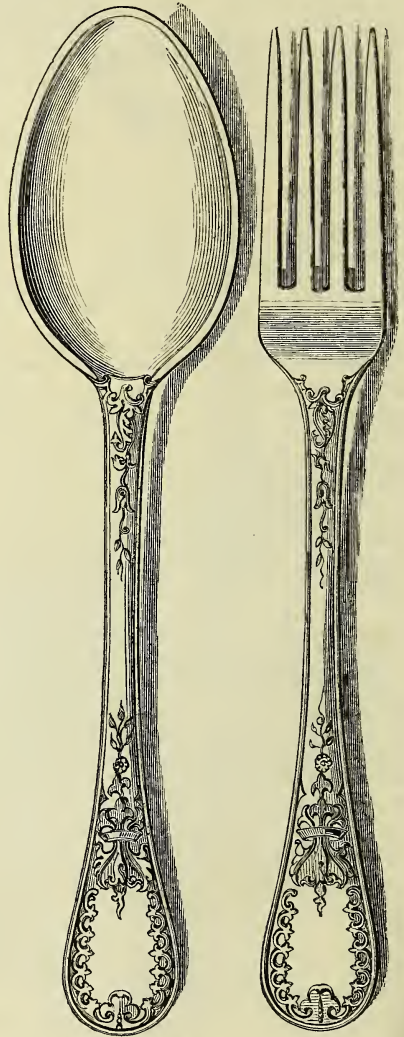

Attenborough's Spoons and Forks.

An agricultural prize cup, the stem a tree; the body, cattle, steam-engine, church, &c., with figures of Time and Plenty.

Enamelled riband bracelet; brilliant ruby wreath. Brilliant and purple enamel bracelet. Brilliant bouquet bracelet.

Engraved gold riband bracelet; enamelled and pearl wreath.

Brilliant scroll, and green enamelled bracelet; registered band, the centre forming brooch at pleasure. Emerald and brilliant bracelet.

Diamond and ruby riband, bracelet; turquoise, enamel, and gold band.

Brilliant scroll bracelet, ruby centre, registered band. Bracelet, with brilliant and ruby rose-bud centre.

Bracelet with brilliant and enamel vine-leaf pendant.

Bright gold-plait band bracelet. Registered.

Coloured gold-plait band bracelet. Registered.

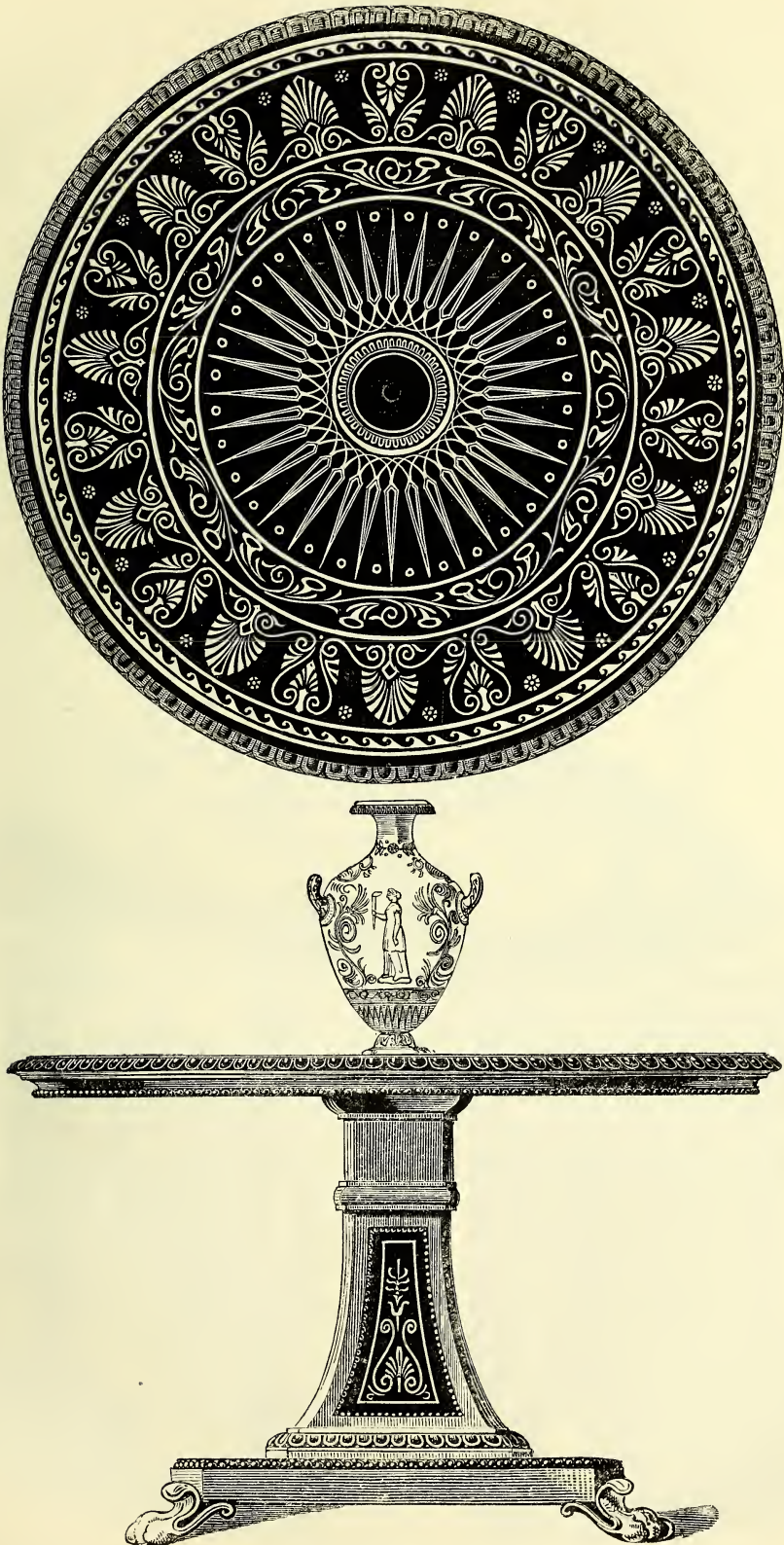

Riband pattern brooch, with pearl and enamelled wreath. Knot pattern brooch, with pearls and enamel.

115 HIGGINS, FRANCIS, 40 Kirby Street, Hatton Garden—Designer and Manufacturer.

Table and dessert cutlery, with silver and ivory handles, steel and silver blades. Silver table and other spoons and forks, of a new design; and ornamented silver and gilt articles for dessert services. Electroplated, on white metal, table spoon and fork.

116 MOTT, WILLIAM, 36 Cheapside—Proprietor.

Gold and silver ever-pointed pencils, in various styles, set with jewels.

117 MOREL, J. V., & Co., 7 New Burlington Street, Regent Street—Manufacturers.

Equestrian statue of Queen Elizabeth, after the bas-relief on the state-seal of England, under her reign. Height 4 feet 2 inches, length 3 feet. Embossed with the hammer, forming a specimen of the real work of the silversmith—that is, beaten out with the hammer only. This manner of working was practised in the sixteenth century, was revived in 1838, and has since been successfully applied.

[The exhibitor directs attention to the important distinction between cast and hammered work, commonly called *repoussé*, of which Cellini says—"Contiene in se piu virtuosa pratica." Castings once made may be repeated in mass or in detail; whereas, every separate article in *repoussé* requires the same labour and dexterity, which, though a fault in a mere manufacture, adds value to a work of art. The earliest method of using the precious metals seems to have been in hammered plates, probably applied to a frame of timber, and in the Minerva of Phidias, forming a gold and ivory statue of nearly 40 feet high. Cellini describes the method of working large statues, "Laveri di grosseria," in his day.—H. T. H.]

Centre-piece in silver of elaborate design, modelling and chasing. Height 2 feet, length 3½ feet, weight 1,276 ounces. The subject, a troop of children playing with a panther. The scene a rock surrounded by water slightly undulated. Branches of ornamental leaves springing up from the sides, and terminating in a basket for flowers, form a sort of canopy over the group; twelve smaller branches spring out of the large ones for candles.

Embossed and chased silver vase, surrounded by a boar-hunt in bas-relief, in the mediæval style, and surrounded by a group representing the death of the boar.

Large mirror for the toilette, in silver, in the Louis XV. style, surrounded by figures of children and animals in full relief, in the ornaments.

Sugar-basin, with salver, in silver gilt, in the shape of a vase.

Chased cake-stand in silver, with figure and branches for lights, with design.

Saltcellars representing figures on donkeys with baskets, embossed and chased; and figures holding baskets, modelled and chased.

Tea service with tray in silver gilt, chased and decorated in the style of Louis XIV. Small tea service in silver gilt, in the Turkish style.

Paper-weights in silver; a stork and a pelican, chased design.

Silver gilt vase with handle, representing a dragon, and a scroll for inscription supported by children.

Oriental agate cup mounted in gold and enamel.

Lapis lazuli cup in the form of a sea-shell, supported by a mounting in gold and enamel, representing a Triton and a Naiad with sea-plants.

Oriental agate cup supported by a group of figures, the handle being formed by the flowing scarf of a female seated on a dolphin, &c. In gold and enamel.

Vase in rock crystal, mounted in gold and enamel, with figures and ornaments.

Plateau in jade, mounted in silver gilt with enamelled figures and ornaments.

Oriental agate vase on a plateau of the same; mounting in gold and enamel, consisting of a figure of Neptune seated on a sea-dragon and a chimera for the handle.

Rock crystal vase, mounted in silver gilt with ornaments and bas-reliefs in gold and enamels. The preceding seven articles are all in the mediæval style.

[In 1630, Toutin is said to have invented painting in enamel on an opaque white ground; but it was Petitot who brought the art to the highest perfection in the same century, and his portraits for dexterous manipulation, exquisite colour and finish, are still unsurpassed. His plates seldom exceed two or three inches; but there is a full-length portrait by him, after Vandyck, in the Duke of Devonshire's collection, 9½ inches by 5½. Petitot was born at Geneva, 1607, and died 1691. His works are numerous, as he was assisted in his back-grounds and draperies by his brother-in-law, Peter Bordier. He was patronised by Charles I.—J. H.]

The same articles in the taste of the costly antique, with mountings of sardonyx, bloodstone, lapis, rock-crystal, &c., of the sixteenth century, as extant in the richest public and private collections of objects of art.

Zarfas, or Turkish coffee-cups, of different designs, enamelled on gold with views of Constantinople, and set with diamonds.

[Enamels are seldom done in any considerable size, from the great difficulty attending the preparation of large plates; indeed, it is a style of painting to which delicacy and finish seem more suited than large dimensions.

The largest work said to have been executed on metal is in Her Majesty's collection, "The Holy Family," after Parnegiano, by Charles Muss; it is about 21 inches by 16. The Bacchus and Ariadne, by Titian, was copied by Henry Bone, R.A., on a plate 18 inches by 16: it was sold for 2,200 guineas. Muss died young in 1824, and Bone in 1834, aged 79.—J. H.]

Bouquet, composed of diamonds, and a great collection of rubies, separating into several different ornaments.

[The oriental ruby most esteemed by the jeweller is classed as a red sapphire by the lapidary, whose test is not colour but specific gravity and hardness. The ruby spinelle, according to the latter test, is the genuine ruby, and is less hard and heavy than the oriental.—H. T. H.]

Casket in the Florentine style, made to contain an autographical work by M. Guizot, entitled "The Life of Washington," and presented by the author to M. Libri.

Mountings in precious stones, such as bracelets, brooches, and other fancy articles of jewellery in gold and silver.

118 ROWLANDS & SON, 146 Regent Street—Manufacturers.

Brilliant and ruby bracelet, after the Holbein style.

Brilliant and ruby stomacher brooch, original design.

Gold and enamel bracelet, with carbuncle and diamonds, in the style of the 15th century, grotesque design.

Gold and enamel brooch, in same style, with figures, &c.

119 EMANUEL, MICHAEL, 5 Hanover Square—Manufacturer.

Large silver clock, surmounted with a figure of Apollo, driving the chariot of the sun, with four horses; supported by four figures of the Seasons. In the centre of the frieze are represented the four winds, &c. In front of the dial is a figure of Time, in a recumbent posture. Designed and modelled by Woodington.

Large silver ewer, with figure handle, chased, in bold relief; on one side is depicted a lion hunt, on the other, Jason landing at Colchis.

Silver dessert stands. Elaborately chased tea and coffee set, of new design. Large gilt candelabra.

A large gilt plateau, with turquoise China racks and medallions, with figures in centre, supporting branches for lights; at the base are groups of figures and horses.

Natural crystal columns mounted as candlesticks, in silver gilt, with amphibious figures at base.

Series, showing gold in its various stages of progress, from the ore to the manufactured article.

120 SHARP, THOMAS, 27 *Burton Crescent*—Designer and Manufacturer.

Shakspeare cup, in silver, with subjects from Lear, Julius Cæsar, The Tempest, Othello, Hamlet, and Macbeth. In the divisions on the foot are emblems referring to the groups above. Under Lear, two serpents; under The Tempest, sails, a compass, and a wand; under Othello, the Venetian lion; Danish emblems under Hamlet; and witches' cauldron under Macbeth.

Cup in silver, representing Justice driving Violence, Fraud, and Discord from the earth.

Candelabrum, electro-plated on German silver, with St. George and the Dragon. Electro-plated épergne.

121 KEITH, JOHN, 59 *Britannia Terrace, City Road*—Manufacturer.

Specimens of communion plate as used in the Church of England; manufactured for the Ecclesiological Society.

122 DODD, PHILIP GEORGE, 79 *Cornhill, Royal Exchange Side*—Proprietor.

Silver tea and coffee service, embossed with basso-relievo figures, representing the Seasons.

Etruscan silver tea and coffee service, engraved with bouquets of flowers. Silver claret jugs.

Silver inkstand, in style of Louis Quatorze, surmounted by figures emblematical of science. This inkstand is represented in the adjoining illustration.

Silver fruit or ice dish, supported by dolphins.

Silver circular cake baskets, engraved in compartments.

Ornamented silver flower vase. Child's silver mugs, with figures. Silver sugar baskets.



Dodd's Louis Quatorze silver Inkstand.

123 STONE & SON, 7 *Myddelton Street, Clerkenwell*—Manufacturers.

Standard gold Californian guard. Nepaulese, and other guard chains. Prince Arthur, Albert, and Imperial chains. Carbuncle and diamond bracelets, and gem rings.

124 HANSEN & DE KONING, 440 *Soho Bazaar, and 50 Dorset Street, Portman Square*—Artists.

Works in human hair:—Basket: flowers in natural size, in relievo. Ornamental family souvenir. Frame containing the portrait of the Prince of Wales, &c. View of Kensal Green Cemetery, in relievo.

125 TOWNLEY, R., 6 *Cursitor Street, Chancery Lane*—Manufacturer.

Specimens of hair, plaited by machinery.

126 LIAS & SON, *Salisbury Court*—Manufacturers.

Silver articles, various in styles and patterns:—Claret jugs; coffee-pots; tea-pots; sugar-basins; cream-jugs; cruet-frames; salt-cellar; knives, forks and spoons; sugar-lifters, &c.

127 DONNE, WM., & SONS, 51 *Cheapside*—Engravers.

Silver tablet (intended for a Bible binding) engraving, Mr. Armitage's cartoon, "The Spirit of Religion."

Another engraving, Mr. Calcott Horsley's cartoon, "The Spirit of Religion."

Various specimens of heraldic engraving on silver plate. Gilt spoons and sugar tongs, with 24 engravings of scriptural subjects.

128 MASON, JAMES, 4 *Gate Street, Lincoln's Inn Fields*—Manufacturer.

Embossed gilt rose-water dish, in the Elizabethan style. Gilt communion cup and plate, embossed in the Elizabethan style. Electro-plated communion cup and plate, same style.

Silver plated portable sacrament cups and plates in cases. German silver electro-plated wrought candlesticks.

129 SKIDMORE, FRANCIS, & SON, *Coventry*—Manufacturers.

Chalices, patens, &c., designed after examples of the goldsmith's art, from the eleventh to the fifteenth century. Holy Gospels, illustrating ancient modes of binding in silver. Offertory dish, centre from design by Overbeck, and decorated with champ-levé enamels. Chalices, patens, &c. Example designed from the writings of Theophilus on the greater chalice with two handles, and the work of the eleventh century.

131 HENRY & Co., 2 *Budge Row*—Manufacturers.

Orders of knighthood, masonic jewels, head ornaments, bracelets, brooches, breast-pins, and finger-rings, in imitation of precious stones. Specimens of stones unset.

140 HER MAJESTY THE QUEEN—Proprietor.

The great diamond called "Koh-i-Noor," or "Mountain of Light."—(*Main Avenue.*)

Jewel case, in cinque-cento style, designed by L. Gruner, Esq.

[The diamond denominated the Koh-i-noor, or Mountain (*Koh*) of Light (*noor*) has long enjoyed both Indian and European celebrity, and has accordingly been the subject of traditional fable as well as of historical record.

According to Hindu legend, it was found in the mines of the south of India, in the days of the great war, (the subject of the heroic poem, or "Mahábhárata,") and was worn by one of the warriors who was slain on that occasion, Karna, king of Anga: this would place it about 5,000 years ago, or 3001 B.C. A long interval next makes it the property of Vikramaditya, the Rajah of Ujayin, 56 B.C., from whom it descended to his successors, the Rajas of Malwa, until the principality was subverted by Mohammedian conquerors, into whose hands it fell with other spoils of infinite value.

Whatever may be thought of the legend which gives so high an antiquity to the Koh-i-noor, we might expect some more trustworthy information when we come down so low as the beginning of the 14th century, when Malwa was invaded and overrun by the armies of Ala-uddin, the sultan of Delhi in 1306, according to the autobiography of the Sultan Baber, acquired the jewel. That it did become the property of the sultans of Delhi is little doubtful, but when or how is matter of some uncertainty, although the grounds of the difficulty have not hitherto been investigated.

In 1665, Mons. Jean Baptiste Tavernier, an enterprising and intelligent traveller, and an eminent jeweller, (although Ecuyer, Baron d'Aubonne,) visited India especially to purchase diamonds. His profession and his personal character seem to have recommended him to the favourable attention of the nobles of the court of Delhi, and of Aurungzebe himself, bigot as he was, by whose commands, Mons. Tavernier was permitted to inspect and handle, and even to weigh the jewels of the Imperial cabinet. Amongst them was one which far surpassed all the rest in size and value. Tavernier describes it as rose-cut, of the shape of an egg cut in two, of good water, and weighing 319½ ratis, which he says is equal to 280 of our carats; the rati being $\frac{7}{8}$ ths of a carat. In another place he affects more precision, and calls the weight 279 $\frac{9}{16}$ carats, and according to his mode of computing its value, he estimates its price at 11,723,278 livres, or about 466,000*l.* Agreeably to the rule given in Rees's Cyclopædia, its value, if of the weight of 279 $\frac{9}{16}$ carats, should be 625,240*l.* Tavernier is evidently wrong, however, in his calculation of the weight of the Imperial diamond, for the rati, which in its original form is the seed of the *Abrus precatorius*, never weighs even two grains, whilst as equal to $\frac{7}{8}$ ths of a carat of 4 grains, it should be 3½ grains, making the weight of the diamond, 1,118½ grains. The rati or gunja, however, as it is also called, is an actual jewellers' weight rather heavier than the seed, and has been found by trial to be equal to 2 $\frac{3}{8}$ grains. If we call the Imperial diamond 320 ratis, its weight by this scale will be exactly 700 grains or 175 carats, a sufficiently near approximation to the actual weight of the Koh-i-noor, 186 carats, taken with more perfect scales and weights than the Imperial jewellers were likely to have provided, and with more care and deliberation than Tavernier might have

had the opportunity of exercising: of course he took the actual weight with the native standard of weight, the rati, and his valuation of the diamond at 279 $\frac{9}{16}$ carats was the result of a mistaken notion of the weight of the rati. Upon the principle alluded to above, the pecuniary value of a diamond weighing 186 carats would be but 276,768*l.*

According to the same authority, this large diamond was found at one of the Golconda mines, which he calls Gáni, and which he visited: situated seven days east from Golconda. Gáni means merely mine, and the place is known as Gáni Partiala: it was visited by the late Dr. Voysey, about 1823, and is described by him as situated three miles from the bank of the Krishna river: it is still worked, but the operations of the natives are confined to the rubbish of former excavations. (Asiatic Researches, vol. xv.) Tavernier states, that it had been first worked only about a century before, and that the great diamond had become the property of the chief Vazir of the last but one of the independent kings of Golconda, who betraying the interests of his master to the emperor Shah Jehan, secured the emperor's favour and protection by presenting him with the jewel: when it was given to Shah Jehan it was uncut, and then weighed 900 ratis, which by Tavernier's reckoning would have been equal to 787 carats. This great reduction in the weight he considers to have been the fault of the lapidary, one Horrenso Borgio, a Venetian, for he says, if he had understood his business, he might have extracted from the jewel something worth having, and yet done no wrong to the emperor, but left it much heavier than he did. The emperor was exceedingly displeased with him, and not only refused to pay him for his labour, but amerced him in 10,000 rupees; he would, says Tavernier, have levied a heavier fine, but it was all that the Venetian had.

Now all this seems very plausible, and we cannot doubt that Tavernier saw and handled a diamond in the Delhi cabinet, which in shape and weight approaches so closely to the Koh-i-noor, that it is very likely to have been the same; as it were very improbable that there should be two diamonds in the world so similar to each other. The subsequent fortunes of the diamond of the Great Mogul confirm the identification; but the same resemblance occurring in a jewel elsewhere described, throws great doubt upon Tavernier's story of the cutting of the stone, and renders it almost certain that his account of its origin and of the manner in which it came into the possession of Shah Jehan is altogether inaccurate.

The Pathan kings of Delhi were supplanted by the Moguls of the house of Timur in the beginning of the 16th century, and the first of the dynasty, Baber, became sovereign of Hindustan, by the defeat of Ibrahim Lodi, in 1526, or 139 years before Tavernier's visit to Delhi. Baber, as is well known, wrote, or at least dictated, his own memoirs, copies of which are not rare, and which have been translated into English by the late Dr. Leyden and Mr. Erskine. Immediately after the battle of Panipat, Baber sent his son Humayun against Agra, the citadel of which had been held for Ibrahim by Bikermajit or Vikramaditya, Raja of Gwalior, who had been also killed at Panipat. As Baber relates the story, "The family of Bikermajit and the heads of his clan were at the moment in Agra. Upon Humayun's arrival they attempted to escape, but were stopped by the parties stationed to watch their movements, and were brought in prisoners. Humayun would not permit them to be plundered, and of their own free will they presented to him a peshkash, consisting of a quantity of jewels and

precious stones; amongst which was one famous diamond which had been acquired by Sultan Ala-ud-din. It is so valuable that a judge of diamonds valued it at half of the daily expense of the whole world; it is about 8 mishkals in weight: on my arrival Humayun presented it as a peshkash to me, and I gave it back to him as a present."—*Mem. of Baber*, 308.

We have here unquestionable testimony of Baber's having come into possession of a remarkable diamond, which from its weight and value was very possibly the same that Tavernier saw. The translator of Baber, in a note, makes 8 mishkals equal to 320 ratis, which is the same as Tavernier's specification. According to Ferishta, who repeats the story, the weight was 8 mishkals, or 224 ratis only, which would make it only 491 grains, or 125 carats. Baber's expression, however, is "ghaliban," which would indicate not actual but estimated weight: according to the actual valuation of the Arabian mishkal at 72 grains, the weight of Baber's diamond would be 576 grains; but it is always difficult to fix with precision the value of Indian weights and measures, as they vary in different places and at different times. It is sufficient to determine that Baber obtained a diamond, corresponding nearly if not exactly in weight and value with one found above a century later in the possession of his descendants. The weight, however, of Baber's diamond being much the same as that of Aurungzebe's, the story of the original weight and the loss in cutting is not to be relied on. It might indeed be supposed that we have two different stones intended; but besides the improbability that two diamonds of unusual size, so nearly or so exactly the same, should have been met with, it is worthy of remark, that Tavernier did not see in the imperial cabinet any second diamond at all approaching the great diamond in dimensions—the largest diamond in succession that he saw did not exceed 62 carats. The large diamond in the peacock throne he estimates at 80 or 90 carats, whilst none of the rest were more than 10 or 12. Had there been two large diamonds, one obtained by Baber and the other by Aurungzebe, he would scarcely have failed to notice both.

It still remains to be established, however, how far the great diamond of the Mogul emperors is to be considered as the same with the Koh-i-noor, as that appellation is not given to it by the earlier writers. That the Mogul diamond passed into the possession of the ruling family of Kabul is, however, invariably affirmed by the members of that family, and by the jewellers of Delhi and Kabul, and is by both identified with the Koh-i-noor. We know from concurrent and unquestionable evidence, that Nadir Shah, on his occupation of Delhi in 1739, compelled Mohammed Shah, the great grandson of Aurungzebe, to give up to him everything of value that the Imperial Treasury possessed, and his biographer and secretary specifies a peshkash or present by Mohammed Shah to his conqueror of several magnificent diamonds. According to the family and to popular tradition, Mohammed Shah wore the Koh-i-noor in his turban at his interview with his conqueror, who insisted on exchanging turbans in proof of his regard. However this might have been, we need have little doubt that the great diamond of Aurung-

zebe was in the possession of Mohammed Shah at the time of the Persian invasion, and if it was, it most certainly changed masters, and became, as is universally asserted, the property of Nadir Shah, who is also said to have bestowed upon it the name of Koh-i-noor. After his death, the diamond which he had wrested from the unfortunate representative of the house of Timur, became the property of Ahmed Shah, the founder of the Abdali dynasty of Kabul, having been given to him, or more probably taken by him, from Shah Rokh, the young son of Nadir: the jewel descended to the successors of Ahmed Shah, and when Mr. Elphinstone was at Peshawar, was worn by Shah Shuja on his arm. Mr. Elphinstone refers to Tavernier as having delineated the gem, intimating his impression of the identity of the Great Mogul's diamond and the Koh-i-noor, and Capt. Cunningham in his History of the Sikhs, calls it the great diamond which had adorned the throne of the Moguls.

When Shah Shuja was driven from Kabul, he became the nominal guest and actual prisoner of Runjit Sing, who spared neither opportunity nor menace, until, in 1813, he compelled the fugitive monarch, to resign the precious gem, presenting him on the occasion it is said, with a lakh and 25,000 rupees, or about 12,000*l.* sterling. According to Shah Shuja's own account, however, he assigned to him the revenues of three villages, not one rupee of which he ever realized. Runjit was highly elated by the acquisition of the diamond, and wore it as an armlet at all public festivals. When he was dying, an attempt was made by persons about him to persuade him to make the diamond a present to Jagannath, and it is said he intimated by an inclination of his head, his assent. The treasurer, however, in whose charge it was, refused to give it up without some better warrant, and Runjit dying before a written order could be signed by him, the Koh-i-noor was preserved for a while for his successors. It was occasionally worn by Khurruk Sing and Shir Sing. After the murder of the latter, it remained in the Lahore Treasury until the supercession of Dhulip Sing, and the annexation of the Punjab by the British Government, when the civil authorities took possession of the Lahore Treasury, under the stipulation previously made, that all the property of the State should be confiscated to the East India Company in part payment of the debt due by the Lahore Government and of the expenses of the war. It was at the same time stipulated that the Koh-i-noor should be surrendered to the Queen of England. The diamond was conveyed to Bombay by Governor-General the Earl of Dalhousie, whom ill health had compelled to repair to the coast, and was there given in charge to Lieut.-Col. Mackeson, C.B., and Capt. T. Ramsay, the Military Secretary to the Governor-General, to take to England. These officers embarked on board Her Majesty's steam-ship *Medea*, and left Bombay on the 6th of April, 1850. They arrived at Portsmouth on the 30th of June, and two days afterwards relinquished their charge to the Chairman and Deputy-Chairman of the Court of Directors, by whom, in company with the President of the Board of Control, the Koh-i-noor was delivered to Her Majesty on the 3rd of July—an appropriate and honourable close to its eventful career.]

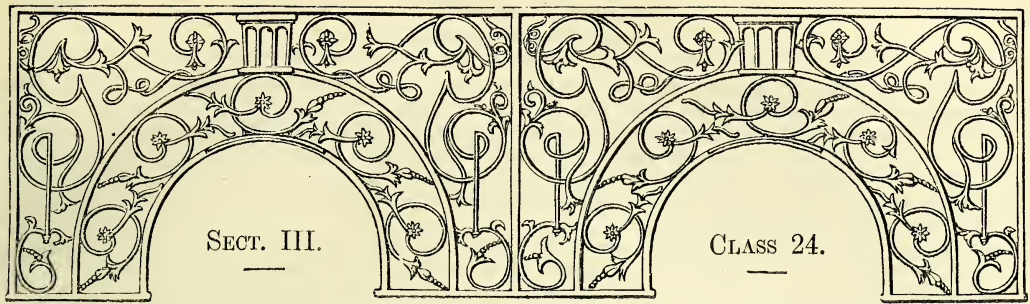

GLASS.

INTRODUCTION.

THE beautiful and valuable production, which forms the subject of the present Class and its subdivisions, is beginning to assume an extraordinary degree of importance in the present day. Yet few manufactures have, until within a very recent period, made so small an amount of progress. Every process of the manufacturer having been beset with the stringent regulations considered to be necessary to enforce the due observance of the Excise laws, and no exemption being permitted even for the purposes of experiment or improvement, it is scarcely a matter of surprise that the production of glass remained in a poor and imperfect state both as a manufacture and as a philosophical problem. The same causes now no longer existing, a vast amount of progress has been made both in the extension of the applications of this product, and also in the processes of its manufacture.

Considered philosophically, the Class resolves itself into the following subdivisions:—A. Window-glass, including Sheet-glass, Crown-glass, and Coloured Sheet-glass; B. Painted, and other kinds of ornamented Window-glass; C. Cast Plate-glass; D. Bottle-glass; E. Glass for Chemical and Philosophical Apparatus; F. Flint-glass, or Crystal, with or without lead, white, coloured, and ornamented for Table Vases, &c.; G. Optical Glass, Flint and Crown.

The position in the Building where articles in this Class will be sought is in the Central North Gallery, where an extremely beautiful and interesting collection of various articles in glass is displayed. Immediately above these articles, and suspended from the girders of the roof, are large and costly chandeliers, of great magnificence of appearance, and in white and coloured crystal-glass. But in other parts of the Building various large objects belonging to this Class are arranged, as in the Transept and Main Avenues. The size of these will not fail to render them appreciable to the visitor. The whole Building may, in fact, be regarded as a display of the powers of the manufacturers of this country to produce rapidly, and from apparently exhaustless resources, this beautiful material.

As the glass, forming so large a portion of the Exhibition Building is of Birmingham production, it may be reasonably imagined that from this town the largest contributions of glass have been forwarded. The glass manufacture being extensive in this place, has become developed to an enormous degree after the removal of the Excise restrictions in 1845. Formerly glass was made in Birmingham only by large manufacturers, but now the commoner kinds of blown and pressed glass are produced in large quantities by persons having only a small amount of capital, manufacturing on a limited scale, at a cheap rate, and requiring a rapid conversion of the proceeds of their little furnaces into money. The glass thus produced is of the most inferior kind, and could only find a sale in consequence of its marvellous cheapness. The works of the great manufacturers are on the most splendid and extensive scale, and in them the manufacture of this strictly chemical product is carried on upon a truly philosophic basis, and on the grandest commercial scale. As an evidence of this may be adduced the production at one great establishment, in addition to their ordinary business, of that vast surface of glass which covers and protects the Building. Probably in no other country could a demand as sudden and unexpected have been met with so much certainty as in the instance in question.

In addition to the glass of the Building, the Great Crystal Fountain, in the Transept, has its interest as a production derived from the same locality. This fountain is twenty-seven feet in perpendicular altitude, and contains about four tons of pure crystal glass. It is probably the largest production of the kind ever made. The great specimens of plate-glass, one of which exceeds considerably the size of any previous sheet of glass made in any country, are not exclusively from Birmingham. St. Helen's, Sunderland, Newcastle, and other localities, contain large glass-works, some of which are exclusively devoted to the manufacture of plate-glass, which is a very distinct art from that of ordinary glass. Bottle and chemical glass is produced on a vast scale at Stourbridge, a locality possessing several natural advantages for the prosecution of glass-melting. Glass-houses exist in the Metropolis itself, which turn out principally table and ornamental glass.

A most remarkable circumstance in the history of the glass manufacture is the fact that, during half a century prior to the removal of the duty, notwithstanding the augmentation of the population, there was actually a decrease in the quantity of glass manufactured. Since 1845, however, it has immensely increased, and is daily receiving new applications, the value of the material for a variety of purposes having long been recognised, but its employment being rendered impossible by the excessive duties to which it was subjected.

English manufacturers have lately been making important experiments with a view to discover a method of producing glass free from colour, and from *stricæ*, for optical purposes. Several specimens are exhibited in illustration, and appear to promise favourably for the issue. The great refracting Telescope in the Nave is an

evidence that large achromatic glasses, nearly a foot in diameter, are capable of being produced from English glass. Hitherto much of the optical glass has been derived from abroad. It is a gratifying fact that already glass is beginning to be actually exported for the use of continental opticians, and it is sometimes reimported at a higher rate into England, under the assumed title of foreign glass. Successful attempts to imitate the beautiful art of the Venetians in ornamental glass have lately been made, and specimens are exhibited. New and patented processes of silvering glass, not with mercury, but with a deposit of pure silver, receive a variety of beautiful illustrations in different objects.

It would be difficult to name another material which could, with any advantage, take the place of glass in its domestic, economical, and philosophical purposes. The facility of its manipulation, combined with the beauty of the material, and the perfect applicability to the purposes for which it is designed, render this manufacture one of the most interesting, and probably ultimately among the most important, of this country. England possesses great facilities for the production of the best glass, on the largest scale and at the cheapest rate. In her natural stores of fuel, in her commercial resources of alkali, and in the possession of the requisite capital to enter largely into this branch of industry, this country appears to require nothing beyond a short space of time to assume one of the first positions in the manufacture of glass. And the variety of interesting facts which become daily linked with the progress of this art, appear to leave little doubt that, ere long, glass will be substituted for many of the materials used in the economy of our dwellings, and probably for their construction also.—R. E.

1 ROSS, O'CONNOR, & CARSON, *Belfast*—Manufacturers.
Watch glasses, in all stages of manufacture.

2 HETLEY, JAMES, & Co., *35 Soho Square*—Producers.
Glass shades—round, oval, and square, of various sizes. Bas-reliefs in fictile, or imitation ivory. "The Writing-master," and "The Musician"—a pair, painted by Gerard Dow, modelled by George Abbott. "The happy age of Infancy," painted by Martin, modelled by R. C. Lucas.

3 KIDD, WILLIAM, *12 Poland Street, Oxford Street*—Inventor and Manufacturer.
New process for illuminating, embroidering, and silvering flat surfaces in glass; applicable to a variety of subjects strictly ornamental. The designs are engraved on the under side of the glass, although they appear to the eye as if embossed in high relief on the outer surface.

4 SWINBURNE, R. W., & Co., *South Shields and Newcastle-on-Tyne*—Manufacturers.
Silvered, naked, rough, and Venetian plates of glass. Opaque plates of glass, intended as a substitute for marble in articles of furniture, &c. Perforated plates of glass for ventilation. Glass domes for skylights. Opaque glass table. Glass pipes, with Mayo's patent joints, for conveying water and other fluids. Sets of chemical apparatus for manufacturing purposes. Glass trays, for dairy and domestic purposes.

5 PINKERTON, JOHN, *143 High Street, Borough*—Designer, &c.
Plated metal dessert plates, inlaid with ornamental cut glass. Globe on pedestal, ornamental cutting, plated metal reflector inside; painted inside, with plated metal reflector; and ruby and blue ornamental cutting. Glass dish for chandelier, ornamental cutting, gilt metal reflector inside. Vase for chandelier. Ruby glass dish for chandelier, ornamental cutting, plated metal reflector inside. Vases. Candlesticks, inkstand, and dessert bowl, plated metal reflector outside, ornamental cutting. Sugar-basin on foot. Flower vase, ornamental painting, reflector inside.

6 THE AIRE AND CALDER BOTTLE COMPANY.
BREFFIT, EDGAR, *Castleford, near Pontefract*—Manufacturer.
Bottles for dispensing purposes. Bottles for confectionery. Fruit, pickle, sauce, and liqueur bottles. Wine and beer bottles. Bottles for coffee, spices, &c. Bottles for druggists' use, with improved pressed stoppers. Bottles for soda-water and other gaseous liquors. All of these furnished with patent hollow corks and combination stoppers.

Bottles for miscellaneous purposes. Patent hollow corks. Patent combination stoppers. Glass tablets, with inscriptions. Glass insulators, for electric telegraphs.

7 WOOD & PERKES, *Worsbro' Dale, near Barnsley*—Manufacturers.
Glass taps of different sizes, with plugs secured. Ruby epergne, and the stand forming a separate fruit and flower vase. Glass inkstand and wafer-box.

8 SHEPHARD, JAMES, *5 Crawford Passage, Ray Street, Clerkenwell*—Inventor.
Glass tubing, with screwed connections, for water, gas, or chemical purposes. New glass stopcocks, for chemical purposes. Specimens of screw-cutting in glass.

9 SANDERSON, RICHARD, & SON, *9 Brooke Street, Holborn*—Inventors and Manufacturers.
New partition glass, for Seidlitz and other effervescing powders.

10 OHLSON, JOHN, *70 Union Street, Southwark*—Manufacturer.
Glass dishes, showing glass-cutting in three different stages, viz., cutting, smoothing, and polishing.

11 JONES & SONS, *5 Ludgate Hill, London*—Designers, Inventors, and Manufacturers.
Mantel-piece girandoles, for two lights each, with glass shades and gilt stands. Specimens of cut glass, door handles, shutter nobs, bell-lever, and escutcheons, in chased water-gilt mountings. Cut-glass cornucopias, on plinths, chased, and water-gilt, mounted complete with shades and gilt stands. Ruby glass decanters, engraved. Cut-glass bowl, exhibited for workmanship. Cut-glass basin, with cover and stand. Cut table glasses. Cut-glass service. A pair of candelabra, for five lights each; designed for a console table, ornamented, cut, and mounted in chased and water-gilt metal work.

12 GATCHELL, GEORGE, *Anne Street, Waterford, Ireland*—Manufacturer.
Etagère, or ornamental centre stand for a banqueting table; consisting of forty pieces of cut glass, so fitted to each other as to require no connecting sockets of any other material. Quart and pint decanters, cut in hollow prisms. Centre vase, or bowl, on detached tripod-stand. Vases with covers. Designed and executed at the Waterford glass works.

13 **MOLINEAUX, WEBB, & Co., Manchester—Manufacturers.**

Specimens of cut, engraved, and coloured glass, consisting of water jugs and goblets, wine and other decanters and claret jugs.

Finger-basins and coolers. Champagne, hock, and other glasses. Sugar-basins and cream-ewers. Flower and other vases. Dessert dishes. Centre-pieces, &c.

14 **RICHARDSON, W. H. B. & J., Stourbridge—Manufacturers.**

Cut crystal glass: consisting of centre-dish and stand, complete; with the following articles to correspond: 10 and 8-inch oval dishes, 9-inch plate, sugar-basin, quart decanter, and goblet.

Jugs, decanters, butter stands and covers, sugar-basins, oval dishes, celery glasses, goblets, and claret bottle, &c.

A great variety of cut and engraved glass applied to useful and ornamental purposes.

A variety of articles in coloured, frosted, and painted glass.

Opal vases, painted with enamel colours: subjects—Ulysses weeping at the song of Demodocus—Judgment of Paris—Diomed casting his spear at Mars—Dream of Penelope—Loch Oich—and from Æsop's Fables, the latter gilt; and various others.

Flower-vases of gilt; ruby, black, and flint-glass, cut and gilt; opal glass, painted—Pet Fawn—in enamel colours; opal glass, ornamented with enamel colours—Grecian figures.

A large collection of vases, jugs, cups, dishes, decanters, and glasses, exhibiting various modes of ornamentation, modern and Venetian.

Match pots with cover for taper, opal glass, ornamented with enamel colours and crystal glass as specimens.

[The glass manufacture at Stourbridge was introduced about 1556, by a number of refugees from the province of Lorraine, headed by an individual of the name of Henzole, now Ensell. The first glass-house was erected in 1557, at a spot near Stourbridge, and is still known by the name of "Hungary Hill." The existence of fire clay, and coal in the district, doubtless, in some measure, determined the localization of glass-making in this district: the sand is brought from a distance. To a descendant of the same family is due the merit of being the first to introduce an improved method of making the German-spread plate glass, as also the construction of an annealing chamber, or "side-lear;" the annealing process, previous to this, having been effected by placing the articles made above the top of the furnace.—W. C. A.]

15 **DAVIS, GREATHEAD, & GREEN, Stourbridge—Manufacturers.**

Quart decanters, of various patterns; water jugs and goblets: celery glass; finger-cups; tumblers; sets of liqueurs; wine, claret, and champagne glasses and goblets; centre dishes and stands; oblong dishes; cream-bowls; sugar-basins; butter-coolers; plates; pickle-jars, salt-cellar, and cream-jugs, of flint material and cut.

Lustres, in ruby and chrysolite, with flint drops, cut and enamelled, and frosted.

Ruby centres and stands, finger-basins, ice plates, and hock glasses.

Liqueur bottles, ruby, blue, and green, coated on flint.

Ruby and opal lamp pillars, cut, enamelled, gilt, &c.

Venetian goblets, wines, clarets, and champagnes, cut. Enamelled finger-basins and ice plates.

Italian landscape, painted on opal plate.

Enamelled card-basket mounted, royal plate, and curtain pin.

A great variety of vases, jars, and scent-jars, and scent-jars for holding flowers, &c., in the Egyptian, Etruscan, and Grecian styles; many of them cut, coated, gilt, painted in enamel colours, after the antique, with figures, ornaments, flowers, landscapes, and marine views,

of the following colours, viz., ruby, oriental blue, chrysolite, turquoise, black, rose colour, opal-coated blue, cornelian, opal frosted, pearl opal, mazareen blue, &c. Topaz, flints, &c.

The black slabs upon which the vases stand are cut flint glass.

Specimens of the raw materials, from which the above articles were produced.

The whole of the labour and ornamentation performed by English workmen.

[*Enamel Colours.*—Enamels or vitrified colours, when applied to glass, are composed of a metallic base or oxide in connection with a flux or glass which melts or vitrifies at a lower temperature than the object to be ornamented or enamelled; the enamel is ground upon a glass slab with a glass muller in some essential oil, and is applied with a brush. An attention and a knowledge of the effect of heat on colours is essential to a successful enamellist. If the muffle acquires too great a temperature, the colour flies, or the object is distorted and rendered valueless.—W. C. A.]

16 **WOOD, THOMAS, Stourbridge—Engraver.**

Glass:—Blue cased dish; champagne bottle. Stained ruby bottle. Flint decanter. Tumbler. Ruby hock glass. Stained claret. Flint claret. Flint wine.

17 **WEBB, THOMAS, Platt's Glass Works, near Stourbridge—Manufacturer.**

Various patterns of glass, consisting of bowls and pedestals, dishes, sweetmeats, sugars and cream bowls, butters, ice-pails, plates and floats; pine stands, jugs, goblets, decanters, wines, liqueurs, fingers, coolers, tumblers, ales, salts, mustards, pickles, custards, jellies; soda goblets, flower vases, toilettes, pedestal lamps, lustres, &c.

18 **LLOYD & SUMMERFIELD, Birmingham Heath, Birmingham—Manufacturers.**

Table and dessert service of cut, plain, engraved, indented, embossed, rough and cut glass.

[Glass is engraved by the operation of small revolving copper-wheels upon a lathe, of which the spindle revolves with great rapidity; the copper disc is occasionally touched with emery and oil, which cuts the glass with ease.—W. C. A.]

Hall lamp, finely cut, intended for the use of gas or candle.

Glass medallion busts of the Duke of Wellington and Sir Robert Peel, in glass frame.

Specimens; materials of which flint glass is composed: sand, lead, potash, and saltpetre, in different periods of fusion till the perfect glass is obtained. Natural fracture of flint glass not annealed. Water fracture. Fracture of glass long exposed to intense heat.

Busts of Her Majesty the Queen and His Royal Highness Prince Albert.

19 **BACCHUS, GEORGE, & SONS, Birmingham—Manufacturers.**

Flower-stand, with vase and cornucopias. Vase, cased enamel on ruby, engraved. Grape dish. Decanter, threaded and engraved. Tazza, with spiral stem.

Groups of wine glasses, champagne glasses, and goblets. Sugar-basin and butter-dish, cased, enamel on green, with gold leafage.

Decanters, flint glass, cut and engraved. Goblets, various colours, cut and ornamented. Claret jug. Card-dish, cased, blue, on flint, cut in diamond panels, &c.

Vase, cased, ruby and white, cut and ornamented; vase, cased, enamel on flint, cut and engraved.

Jug, cased, enamel on blue flint, cut, engraved, and gilt, with goblet. Jug, cornelian, with goblet.

Decanter, Pomona green, cut. Champagne decanter, cased, ruby on flint, cut and engraved, with champagne glass.

Cut-glass vase, "cased." Wine, claret, and champagne glasses, cased, coloured, and flint glass, cut, engraved, &c. Cut-glass butter-dish, cased, enamel on yellow. Vase, green and white, ornamented. Cut-glass centre dish and stand, green.

[Many of the specimens here exhibited are of "cased glass." This term is applied to glass which has received one or more layers of coloured glass upon its surface when heated. The manipulation is extremely simple. A ball of colourless transparent glass is collected by the blower, which forms the body, upon which a hollow case of coloured glass is placed, and these are then welded together by heat. When the mass thus formed is blown into shape, and the exterior casing cut through, the appearance of a partly coloured and partly colourless glass is presented. In some instances, three or more casings of different colours are applied, each of which may be rendered visible by cutting through the overlying casings. The Portland and Naples vases were made by "casing."—R. E.]

20 OSLER, F. & C., 44 Oxford Street, and Broad Street, Birmingham—Manufacturers.

Large fountain, in cut crystal glass, 27 feet high. (*At the intersection of the Main Avenue and Transept.*) This fountain is represented in the accompanying Plate.

Candelabra (a pair), in cut crystal glass, carrying 15 lights each, height eight feet; the property of the Queen.

Crystal glass candelabrum, supported on three griffins, in frosted glass.

Large table candelabrum, in crystal glass, with prismatic shaft.

Large lustres, mounted, with crystal prisms.

Busts of the Queen and H.R.H. Prince Albert, in frosted glass.

Busts of Shakspeare, Milton, Scott, and Peel, in frosted glass.

[These busts are produced in moulds, and the enamel or bright surface of the glass is removed by abrasion or grinding; their effect is pleasant, and would seem to indicate that larger works might with propriety be undertaken of the same kind and material. Its indestructible character from atmospheric causes would likewise afford a medium for the production of statues and monumental erections superior to marble, which, in our climate, is speedily discoloured and corroded.—W. C. A.]

21 HARRIS, RICE, & SON, Islington Glass Works, Birmingham—Designers and Manufacturers.

Pressed and moulded glass tumblers, goblets, wines, sugar-basins, butter-coolers, salt-cellars, honey-pots, door knobs, &c.

[By pressing is meant the mode of producing ornamentation on glass in moulds by pressure, and is effected by a press, plunger, and metal-mould, corresponding in internal shape to the article to be produced. The workman receives from a servitor a melted mass of glass, of which he drops a quantity into the mould, and disconnects it from the rod by cutting it off with a pair of scissors; the mould with the melted glass is then placed under the plungers, it is screwed down, which forces the glass into every marking. Minute fissures or cracks which are observable on the surface are removed by again heating the object made, which is now attached to a "punty," and causing it to revolve while the workman holds against it a piece of timber, the heat of which, when red, speedily fuses the whole of the exterior of the glass article to a uniform surface.—W. C. A.]

Specimens of various articles in flint glass, blown, cut, and engraved.

Ornamental glass, of various colours, opal, alabaster,

turquoise, amber, canary, topaz, chrysoptase, pink, blue, light and dark ruby, black, brown, green, purple, &c., coloured by oxides of copper and gold.

The articles made in these colours are gilt, enamelled, cut, and engraved; they consist of tazzas, liqueur services, compotiers, butter-coolers, sugar-basins, toilet-bottles, claret-jugs, goblets, water-jugs, vases, &c.

[In gilding glass-work, the brown oxide of gold is used, which is ground up with a flux, and eventually with a fat oil. It is worked with a brush, and is then subjected to the heat of a muffle sufficient to melt the flux: it is allowed to cool, when it presents a dim appearance. Its brilliancy is given by burnishing with stone burnishers.—W. C. A.]

Specimens of colours, combined by casing or coating two, three, or even four colours on one another; the external coats are cut through by grinding the outer layer, and the inner ones are thus laid bare, and the desired effect is produced. These combinations of various kinds of coloured glass are applied to the same description of goods as in the former class.

[The operation of coating or casing on flint or other foundation with various colours is performed as follows:—A globe of glass is gathered, of which the vessel is to be made: to this a portion of coloured glass already made concave is applied; when both are in a heated state, they are then pressed together, and a fracture horizontally would show a concentric ring of two colours. If more colours are desired, they are applied in the same manner. It will readily be understood that a cut with a convex-surfaced stone will cut through the various coatings and expose the original body.—W. C. A.]

Specimens of threaded glass.—A kind of glass for which Venice is famous, and where it was for a long time almost exclusively manufactured.

22 CHANCE BROTHERS & Co., Glass Works, near Birmingham—Manufacturers.

Crown window glass, in tables, illustrating various kinds.

Sheet, or cylinder window glass, made of five different thicknesses, weighing respectively 13, 16, 21, 26, and 32 ounces per superficial foot. The building for the Great Exhibition is glazed with the 16-ounce glass.

[The process by which panes of sheet or cylinder window-glass, 49 inches long (the length of the panes in the building of the Great Exhibition) can be made, is very simple and beautiful. A quantity of molten glass having been collected on the extremity of the iron blower, is distended first into a spherical form; it is then heated in the furnace, and the glowing mass is swung round by the workman, who stands on the edge of a pit, until it becomes elongated to the required extent. The cylinder thus formed is then cut off at both ends, is cut through the middle, placed in a flattening furnace, where it is spread out upon a slab quite flat. After being annealed, the pane is completed.—R. E.]

Patent plate glass. The process of manufacture consists in grinding and polishing ordinary sheet glass, in such a manner that the thickness of the glass is considerably reduced. This glass is used for the windows of shops and dwelling-houses; for prints, pictures, looking-glasses, and other purposes.

Coloured window glass. In order to illustrate the difference between solid and pot-metal glass (which is coloured throughout its entire substance) and flashed and stained glass (which are coloured on the surface only), various specimens of coloured glass are combined together; the white ground in the flashed and stained glass has been rendered apparent by being embossed, by which the coloured coating is partially removed.

Glass shades, round, oval, and square.





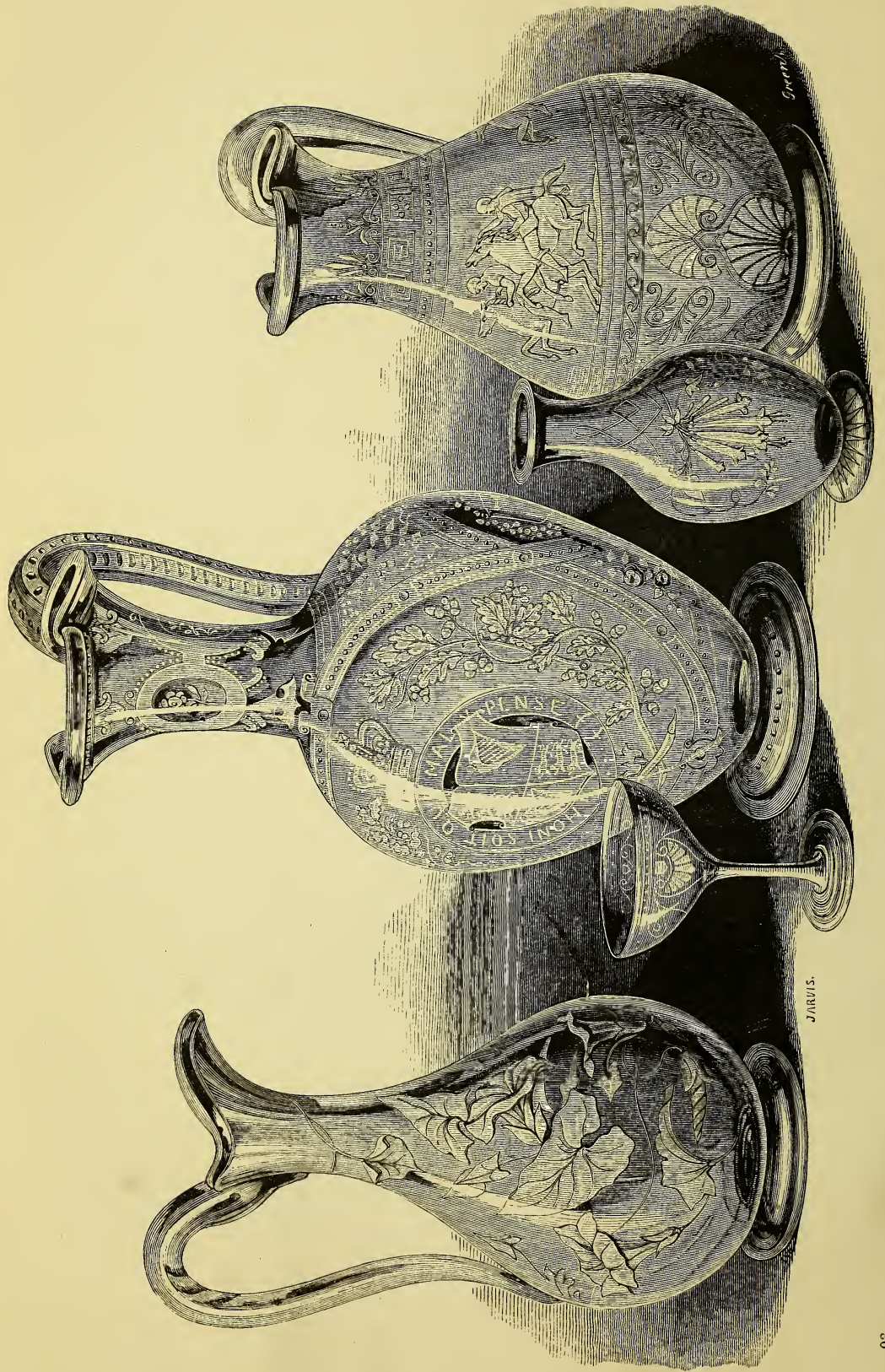

SPECIMENS OF ENGRAVING ON GLASS, MR. GREEN.

Optical glass:—Flint and crown glass in discs of various sizes; and in plates, for the use of opticians; and thin glass used for the polarization of light.

23 **LOCHHEAD, JAMES, 35 Royal Exchange**—Manufacturer.

Patent model windows, fitted with different qualities of perforated plate and sheet glass, for ventilation, showing the various modes of application in fitting, &c. Model mahogany frames. Squares of perforated ventilating glass in various colours, in frames.

Patent ships' ventilating side scuttles, round and square, with shut-off, in perforated plate, sheet, and flint glass.

Patent chimney ventilators, in perforated flint and sheet glass in various colours. Coloured glass gas and hot-air extractors. Model skylight, fitted with perforated ventilating glass.

24 **SHOVE, GEORGE, Deptford, and 488 New Oxford Street**—Patentee and Manufacturer.

Specimens of grained woods, and veined marble, porphyry, agate, and madrepores, figured on the back of plate, crown, or sheet glass, on flat or curved surfaces. Applicable as a veneer to purposes of decoration. The graining and imitation of marbles on glass is the invention of Mr. G. Newbery, and is patent. By embedding upon any solid substance, as stone, slate, tile, wood, &c., with suitable cement, so as to leave no vacuum, there will be no vibration, the two surfaces being in perfect contact; and under these conditions the thinnest glass will "bear the blow of a mallet without breaking." It may thus be regarded as a durable glass varnish. Some of these specimens are painted immediately on the glass, others done by transfer, and all may be vitrified in the usual furnace.

"Window texturalized glass" for blinds, in lieu of wire, &c. The novelty consists in cementing a texture—a muslin, the production of the lace loom, on one side of the glass, which texturalized surface is placed against another pane of glass, and fixed in sashes after the usual manner, with putty, &c. The texture being thus placed between two surfaces, and semi-transparent in its nature, its colours are preserved unimpaired, and it is rendered durable and economical.

Patent detached glass letters.

25 **CLAUDET & HOUGHTON, 89 High Holborn**—Proprietors.

Glass shades, of various large and small sizes, for covering clocks, alabaster ornaments, and any other articles which may require protection from dust or the impurity of the atmosphere.

26 **COGAN, ROBERT, 5 Princes Street, Leicester Square**—Designer and Inventor.

Model of the Great Exhibition Building, of glass and metal.

Patent portable glass pavilion, for lawns or pleasure grounds; when separated forms glass verandas.

Patent portable glass verandas, adapted for the growth and arrangement of flowers, ferns, and other window embellishments; easily converted into a pavilion, or screens for dining-room.

A variety of articles in glass, ventilators, churns, and striking dishes.

Fern temple, of an ornamental description.

Patent dish covers, for cold collations, public breakfasts, &c. Spoons, pens, glass fountain, and screens.

27 **VARNISH, E., & Co., 48 Berners Street**—Patentees and Proprietors.

Plateaux, centre dish. Vase, green and white glass, silvered. Salver, ruby and white; and table, blue and white, silvered. Glass globes, mounted on eagles, atlases, and ornamental stands. Glass goblets and vases, in a variety of colours. Silvered glass reflectors, applicable to all purposes of artificial illumination. Provisionally registered.

28 **CONNÉ, AUGUSTIN, 118 Wardour Street, Oxford Street**—Designer and Artist.

Goblets with ornamental designs. Amber champagne glass, with embroidered fancy border. Ruby wine glass, with vine border, and foot engraved.

29 **VIZETELLY & BRANSTON, Fleet Street**—Manufacturers.

Ornamented glass ware, for architectural purposes, furniture, lamps, gas fittings, &c.

30 **NAYLOR, WILLIAM, 7 Princes Street, Cavendish Square**—Designer and Inventor.

Antique claret jug, engraved.—Registered design.

Massive butter-basin, cover and stand, cut with crowns and Prince of Wales's feathers: the knob of the cover represents a correct profile of the late Duke of York. Antique claret decanter, cut and gilt. Antique claret decanter, engraved with bird and trellis work to represent a cage. Antique water-jugs, cut in character with the shapes, with engraved goblets. Cut and painted flower vase. Decanters, wine glasses, goblets, &c.

31 **POWELL, J., & SONS, Whitefriars Glass Works**—Manufacturers.

Glass pipes fitted with patent joint, for the conveyance of water or gas, for chemical use and for ornamental purposes. Chandelier and glass pump fitted with the same joint. Dessert service, epergne, and other specimens of useful and ornamental glass. Precipitation and other glasses for scientific purposes.

32 **GREEN, JOSEPH GEORGE, 19 St. James's Street, Piccadilly**—Designer and Manufacturer.

Samples of services of glass, engraved in Greek style, in style of François Premier, with thistle and ornamental work, and engraved with various natural flowers. These glass vessels are represented in the accompanying Plate 93.

Large Etruscan-shape jugs: engraved with national emblems; with water lily, shells, and ornamental work, in the style of François Premier, and with figures of Neptune and Amphitrite.

Large Egyptian-shape jug, engraved with Grecian borders. Jugs, Etruscan-shape; engraved with Greek scroll and figures; and with Alhambra ornament.

Claret jugs and glass, engraved. Water goblets, cut and engraved. Glass candelabrum. Chess table, inlaid with coloured glass prisms and glass foot gilt.

Pole fire-screen, with glass screen and pedestal, gilt; pole, with silvered glass screen, gilt pedestal, and foot. Triple group of the water lily in glass, with or-molu stand and bronze leaves and stem; and with electro-silvered leaves and stem. Single group water-lily in or-molu. Assiette monté, in or-molu, with glass dishes and ornaments; the same, in bronze. Back brackets, in or-molu frames and branches, silvered glass backs, cut-glass candleholders and drops.

Registered electro-silvered lamp, pillar, and glass centre, and epergne, stand, and glass dish, in the style of François Premier.

Suspending or-molu chandelier, in Elizabethan style, fitted with glass, silvered by Varnish and Co.'s patent.

33 **PELLATT, APSLEY, & Co., Falcon Glass Works, Holland Street, Blackfriars, and 58 Baker Street, Portman Square**—Manufacturers.

Highly refractive cut-glass centre chandelier, 24 feet long.

Large chandelier of white ruby and blue glass, in the style of Alhambra.

Nine variously ornamented chandeliers.

Group of candelabra.

Cut crystal dessert services.



Apsley Pellatt & Co.'s Anglo-Venetian Gilt and Frosted Glass.

Anglo-Venetian gilt and frosted glass. These specimens are represented in the above cut.

Engraved glass vases and plates. Medical glass, vials, bottles, &c. Deck lights, lanterns, glasses, &c. Cameo incrustations.

Perfumery bottles, lapidary cutting, &c.

Models, and specimens of flint glass, with explanatory catalogue and illustrations.

Specimens of heraldic painting, &c., on china, designed specially for the exhibitor.

Bridal dejeuner service and tray, designed by Mr. Binns and ornamented with appropriate floral emblems. This service is represented in the following cut:—



Apsley Pellatt & Co.'s Bridal Tea Service and Tray.

[*Flint glass* (known on the Continent under the generic title of crystal), besides silica and alkali, contains a large proportion of oxide of lead, for the purpose of increasing its density and brilliancy, and of adding to its ductility whilst in the semi-fluid state.

The silica used is selected of an even and regular grain. The best flint glass is made from sand found at Alum Bay, Isle of Wight, and at Aylesbury, in Buckinghamshire. Before being used, it is well washed and dried, care being taken in the latter process to preserve it from carbonaceous matters.

The alkali potash is always used for the best flint glass, because soda invariably imparts to it a dull grey tint. The carbonate and nitrate of potash are employed in the

proportion of two-thirds of the former to one-third of the latter. In addition to these ingredients, no good flint glass can be made without oxide of manganese. Were all the other materials chemically pure, the glass would not be colourless, but invariably of a green tint, resulting from deoxidation. To prevent this, the oxide of manganese is used. The whole art of producing colourless glass lies in the proper regulation of the quantity of oxide of manganese, which must be augmented with the increased degree of heat to which the materials are subjected. This is a matter of some difficulty. A very small quantity of the oxide of manganese changes the tint of a large body of melted glass; one quarter of an ounce making an apparent difference in colour in 16 cwt. of glass.

Batch (see specimen No. 5) is the term applied to the glass mixture. The usual formula for flint glass is one part by weight of alkali, two of lead, and three of sand; and the closer these proportions can be adhered to, the more compact, refractive, and homogeneous the glass. It frequently happens that, from insufficient fuel or a badly-constructed furnace, these proportions are departed from, more alkali being used in order to secure the fusion of the glass within a given time; but this deteriorates the quality of the glass. To the nature of the fuel in this country is to be ascribed the superior quality of English glass of every description; the molecular structure of which is closer, because it contains a larger proportion of silica than the foreign.

The materials, after having been carefully weighed, are intimately mixed, and upon this depends the homogeneity of the melted mass. The want of this quality in glass is its greatest defect.

It is the want of homogeneity which prevents the manufacture of large achromatic lenses. The attempts to overcome this defect have been but partially successful, and it is to be feared that perfect homogeneity in glass will not be attained, as Dr. Faraday has lately shown that even water, upon becoming ice, often contains striae.

The crucibles for melting the glass mixtures (see model No. 6) are made of "fire-clay," a substance capable of withstanding intense heat for a long period, and of en-

Fig. 1.

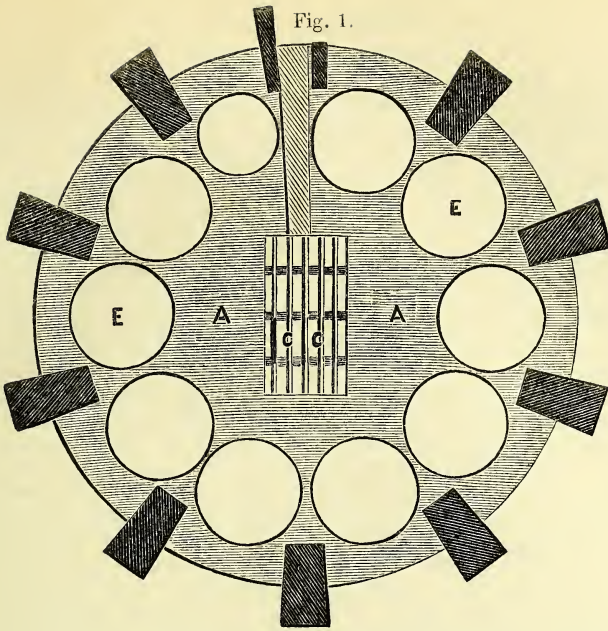

Ground Plan.—AA, "Siege" or Floor of Furnace. BB, Pillars, which support the Crown. CC, Grates. D, Furnace Door. EE, Position of Crucibles.

Fig. 2.

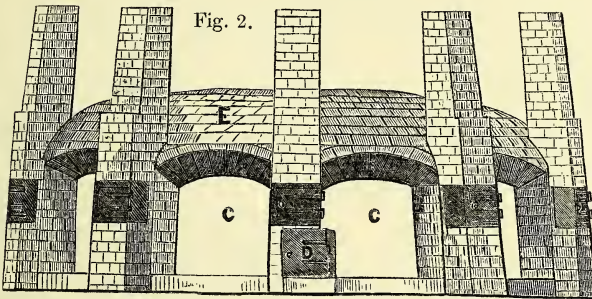

Elevation.—A, Elevation of Siege above the Glass-house Floor. BB, Flues above the Pillars. CC, Openings for Crucibles. D, Furnace Door. E, Reverberating Dome.

Fig. 3.

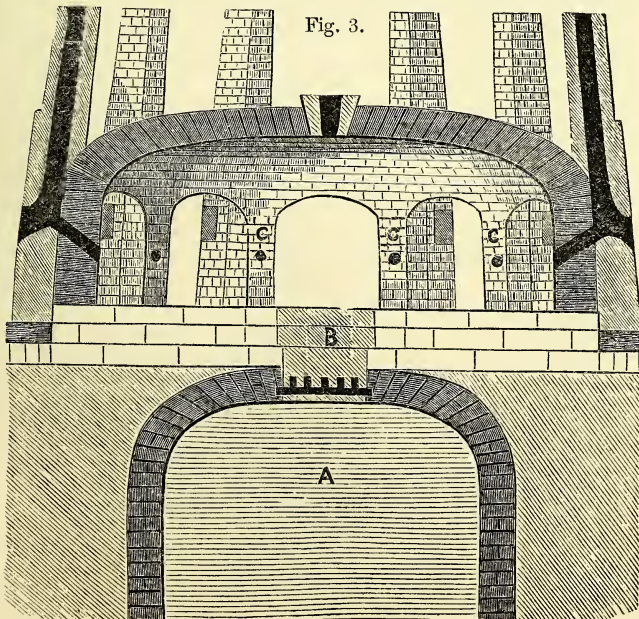

Section of Elevation.—A, Air Tunnel below the Furnace. B, Pit of Furnace, with Grates below. CC, Flue Holes, through which the Flame passes to the Flues above.

during the sudden contraction and expansion to which the crucibles are exposed. The Stourbridge fire clay which is generally used for this purpose, contains $6\frac{1}{2}$ parts silica, and $3\frac{1}{2}$ parts alumina. In forming the crucibles, great care is taken to expel all air-bubbles from the clay, as their expansion by the heat of the furnace would burst the crucibles. They are also very gradually dried and heated to the temperature of the furnace before being placed therein.

Flint Glass Furnace (see model No. 17).—In melting glass, it is not practicable to employ the usual artificial means of obtaining a draught of air, but a constant and regular supply is obtained by a long air tunnel passing below the furnace; the measure and force of the current of air depends upon the height and capacity of the chimney which carries off the smoke of the furnace, and upon the care with which all crevices around the furnace are luted up. The most desirable form of a flint-glass furnace is the circular, and the number of crucibles of the ordinary size, consistent with economy of space, is nine, or at most ten. The preceding engravings, figs. 1, 2, and the following one, fig. 3, are illustrations of the glass furnace.

The materials having been intimately mixed as before described, are added to certain proportions of broken glass. For the very best glass, virgin materials only are used, as every re-melting deteriorates the quality. During the melting, which occupies about sixty hours, the glass assumes different appearances. After the first ten or twelve hours, it appears a honeycombed mass, very white, and perfectly opaque (see specimen No. 8); in a few more hours the opaque appearances yield to a transparent body filled with thousands of air-bubbles (see specimen No. 9); the white colour now gives place to a light purple tint, produced by the oxygen given off from the oxide of manganese. As the melting continues, the purple tint gradually vanishes, the air-bubbles become fewer and larger, and at length quite disappear, when the glass is fined and ready for manipulation.

The tools used in the manipulation of glass are exceedingly simple. They are,—The blowing iron, No. 10; the workman's chair, No. 11; the procellos, No. 12; the punt, No. 13; the shears or scissors, No. 14; the battle-dore, No. 15; the pincers, No. 16. Glass-blowing somewhat resembles the operation of turning. Every article which can be turned by a simple lathe, can be produced in glass by blowing—other shapes require to be blown in moulds. The ordinary mode of annealing flint-glass is by placing the articles, so soon as made, in iron pans within a long low vaulted arch, having a strong fire at either side, at the end nearest the glass-house; a chimney at the other end causes a strong draught, by which the fire is drawn for some distance down the arch (see model No. 17).

Coloured glass is produced by adding, to the ordinary glass mixtures, the oxides or carbonates of certain metals, thereby causing such an atomic arrangement that one or more rays of a pencil of light are reflected. It is usual to ascribe one particular colour to a particular metal—say blue to cobalt, or green to copper; but Bontemps has shown that all the colours of the spectrum may be produced by any one of the ordinary metals, which he ascribed to the degree of heat to which the mixture or the colouring metal is subjected. Iron, copper, cobalt, manganese, gold, and uranium, are the metals used in colouring glass; and these bases, in combination with various proportions of oxygen, produce all the coloured glass in general use.

The ordinary shades of green (specimens No. 18) are

the product of the oxides of iron and copper in different proportions, the yellow tints being due to the iron, and the blue tints to the copper. The carburet of iron gives a dull yellow colour (specimen No. 19); blue (specimen No. 20) is produced by the oxide of cobalt; purple (specimen No. 21) by the oxide of manganese; and the varieties of rose and ruby (specimens No. 22) by the oxide of gold; topaz (specimen No. 23) is given by the oxide of uranium; and emerald green (specimen No. 24) by the same metal, with the addition of a small quantity of copper. Glass is rendered opaque by the addition of arsenic; and the peculiar colour of the opal (specimen No. 25) is produced by the phosphate of lime. The quality of all colour in glass is the result of a proper degree of heat during the fusion of the materials; or, in other words, the prevention as much as possible of deoxidation during the process. A variety of colours upon the same article is produced by thin coatings of each being united in the manipulation; so that in the after-process of cutting, one colour or more is made to appear as may be desired according to the depth of cutting; the difficulty in this process is the proper union of the several glasses—as, should any difference exist in what is known to glass-makers as the “temper of the metal,” the contraction or atomic arrangement during the annealing will vary sufficiently to cause fracture.]

34 **BENNS, RICHARD W.**, 58 *Baker Street*,
Portman Square—Designer.

Miniature fountain for conservatory, with group of Parian statuary in the centre throwing water. The vase and pedestal of japanned slate.

Bridal and birthday déjeûne services, decorated with appropriate sentiments in the language of flowers.

36 **PERRY & Co.**, 72 *New Bond Street*—Designers
and Manufacturers.

Large cut glass chandelier for 144 candles, showing the style of glass-cutting of the 18th century, and modern improvements. A large portion of the glass is cut in what is termed “lapidary-cutting.” The candles are grouped in clusters in the lower tier, and in pendant groups from the upper tier.

37 **DAVIES, GEORGE**, 20 *Wyndham Street*,
Bryansstone Square—Designer.

Painted marbles, opaque, on glass. Adapted for interior decorations, as panelling of all kinds, church altar work, ceilings, &c.

38 **DAVIES, WILLIAM**, 7 *Broadley Street*,
Blandford Square—Designer.

Two opaque paintings on glass, subjects:—“Flowers and vase,” and “Angel rising from the clouds.”

39 **KIDDLE, HENRY EDWIN**, 4 *Elder Street*, *Norton*
Folgate—Producer.

Specimens of marble on glass in one frame, adapted for altar-pieces, facias, plinths, and fancy cabinets, or other ornamental work.

40 **FORD, DAVID**, 4 *James Street*, *St. Peter's*,
Islington—Designer.

Variegated specimens of “*Vitrum marmoratum*,” applicable to all flat surfaces, table tops, tablets, panelling, &c.; the colours are entirely protected from the action of the atmosphere.

41 **HALL, JOHN WESLEY**, *Bristol*—Manufacturer.

Ornamental cut-glass window. Enamelled and embossed ornamental letters.

Embossed British plate, for ornamental doors of halls, banks, coffee-rooms, public offices, &c.

42 FORREST & BROMLEY, *Liverpool*—Manufacturers.
Stained glass window, representing the figure of St. Winifred. Glass chimney-piece.

43 PRICE, JAMES, 7 *Bridge Road, Lambeth*—
Designer and Inventor.
Painted glass door, a specimen of the application of painting on glass to ornamental decoration.

44 JONES, ZEBEDEE, 17 *Park Place, Clifton, near Bristol*—
Designer and Manufacturer.

Top of a table, in "vitrilapis," a new style of ornamental glass, for decorative purposes.

45 BENINGFIELD, WILLIAM, *Colchester, Essex*—
Designer and Manufacturer.

Glass picture-frames, of original design; the gilding or other ornamental work being completely protected.

46 BRAUN, HENRY, 10 *Old Fish Street Hill*—Designer and
Importer.

Ruby cut and engraved cup and cover, manufactured in Bohemia.

46A HANCOCK, RIXON, & DUNT, 1 *Cockspur Street*—
Manufacturers.

Chandelier of cut glass, carrying 32 candles, the upper part forming banners composed of drops; the lower part forming in section, a star, ornamented with cut pendants, and terminating in an imbricated bottom.

47 COATHUPES & Co, *Nicholas Street, Bristol*—
Inventors and Manufacturers.

Glass water-pipes, plain, jointed, and angular. Glass curtain-poles.

[Many waters, and those chiefly of an extraordinary degree of purity, are found to act upon the metallic pipes and cisterns now generally employed. The attention of the most skilful of our engineers and chemists is now engaged on the solution of the difficulty of conveying, uncontaminated, the purest water from the most abundant source: amongst other schemes, the employment of glass-pipes is well worthy of consideration.—W. D. L. R.]

48 FREEMAN, E. & J., 3 *Wynmore Street, Cavendish Square*—
Producers.

Registered model of a percolator.

49 BARNES, WILLIAM, 15 *Grafton Street, Fitzroy Square*—Manufacturer.

A method of decorating and combining together glass and pieces of glass, for interior and exterior decorations; being applicable to church, library, and staircase windows, for illuminations, inlaid borders for halls, &c., being transparent and waterproof.

50 SINCLAIR, C., 69 *Old Street, St. Luke's*—
Manufacturer.

A model, in glass, of a glasscutter's cutting tool.

51 TARIN, M. L. A., 8 *Nelson Street*—Manufacturer.
Magnifying-glass lamp reflectors.

52 SKIDMORE, T. R., 19 *Haymarket*—Manufacturer.
Glass model of a pump.

53 MOORE, J., 33 *Clerkenwell Close*—Producer.
Patent lever ventilator.

54 MASH, J., 93 *Farringdon Street, City*—Patentee.

Patent crystal Venetian blind. This blind combines neatness, lightness, and durability, with utility, and can be made in any design of coloured glass, with the bars either perpendicular or horizontal; also can be fitted either in fancy woods or electro-plated metal frames.

55 PETTIT, ROBERT, *Leves*—Inventor.

A reliquary, or box, for small articles, made of slips of glass.

60 CHANCE BROTHERS, & Co., *Glass Works, near Birmingham*—Manufacturers.

Painted windows:—Leaded work, with medallions and ornamental work of the early Gothic style; and in the style of the fourteenth century, the figures being St. Peter and St. Paul, St. George and Britannia. Armorial decorations. A landscape and ornamental work, suitable for a dwelling-house. Flowers painted and enamelled on a large plate of glass, with borders; the glass having been burnt in a kiln four times.

[The interest attaching to this beautiful art, and its comparatively recent revival, calls for a few remarks. Its antiquity is undoubted. Pliny speaks of "coloured glasses made to imitate precious stones and gems;" and painted glass in the church of Notre Dame, at Paris, is described as early as the sixth century. To Sugerius, abbot of St. Denis, in 1150, is probably owing the re-introduction of painted glass into churches. How rapidly his example was followed, is proved by the magnificent glass of the thirteenth century, abounding on the Continent, and partially existing in this country, the oldest examples we have, being in Canterbury Cathedral. At first the ornaments consisted of mere diapering; then rude representations of saints and kings; then panels of various forms, with subjects from the Testaments, on grounds of blue or ruby, the intermediate parts filled with Mosaic patterns, in rich colours, and the whole enclosed within a coloured border. In later styles, single figures predominated, with flowing patterns of foliage, and, later still, with canopies over them. Some of the finest works are by French and Flemish artists; and this art was traditionally known to the early Florentine painter Cimabue, who is said to have introduced it into Italy. Probably our actual obligations are due to our Norman neighbours, as a necessary appendage to their architecture. It has been a popular notion that this art was lost to us; such is not the case: it has indeed been dormant, but never extinct. The fine works exhibited this year—the production of living artists—announce its revival.—T. H. W.]

61 BAILLIE, EDWARD, 12B *Cumberland Market, and 118 Wardour Street*—Proprietor.

Ornamental stained glass light, containing bust of Queen Elizabeth, the royal arms, &c. Figure kneeling, Ernest the Pious, Duke of Brunswick, an ancestor of the Royal Family of Great Britain. Emblem of St. Matthew. Figure of St. John the Divine, decorated style. Tudor badge. Ornamented light, containing the Order of the Garter, jewels, collar, star, &c. An original historical picture, enamelled on glass, representing Shakspeare reading a play to Queen Elizabeth and court. Small figure of Richard Cœur de Lion. St. John the Baptist, perpendicular style. Emblem of St. Luke. Norman light, with emblem of St. John. Various specimens of decorated lights, emblems, and arms.

62 POWELL & SONS, *Temple Street, Fleet Street*—
Manufacturers.

Specimens of painted and patent pressed glass for windows.

63 HOLLAND, WILLIAM, & SON, *St. John's, Warwick*—
Designers and Producers.

Stained glass of the twelfth century, illustrating scriptural events.

Stained-glass window in the decorated style, for Wellesbourne church, Warwickshire.

Stained glass of the fifteenth century, perpendicular style.

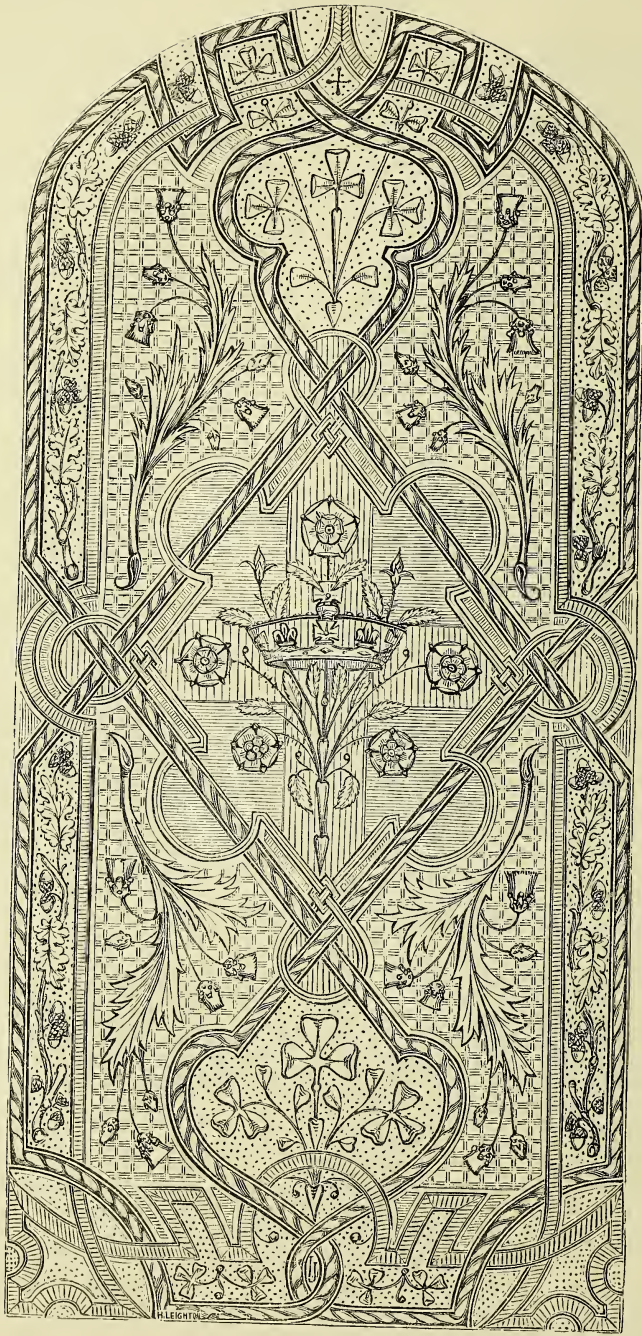

WINDOW COMPOSED OF NATIONAL EMBLEMS, DESIGNED BY LUKE LIMNER,
AND EXECUTED BY THE ST. HELENS PLATE-GLASS COMPANY.

Stained glass window, in the perpendicular style, for Shuckburgh church, Warwickshire.

Stained glass in the Elizabethan style, in which are emblazoned the arms of the sovereigns of England, from Queen Elizabeth up to the present period.

64 BURY, TALBOT, 50 *Welbeck Street, Cavendish Square*—
Designer and Producer.

Stained glass. Compartments of a window for an ecclesiastical building of the second pointed period.

65 O'CONNOR, MICHAEL and ARTHUR, 4 *Berners Street*—Designers and Producers.

Painted glass windows—East window—triplet—for Guiana. Scriptural subject in centre; on either side, figures of St. George and St. Patrick. Arms of England and other heraldry.

Window for Southwell Minster, Notts. Subjects—"Healing the Sick," "Raising the Dead," and "Preaching the Gospel to the Poor."

Salisbury Cathedral—Early pointed window. Subjects—History of Cornelius in three medallions; figures of Michael the Archangel and St. George of England; Grisaille ground.

Memorial to the officers and men of the 62nd Regiment, who fell in the Sutlej campaign.

St. John's Cathedral, Newfoundland;—"St. John the Baptist in his childhood," and his mother.

Some specimens of rich mosaic back grounds, antique figures, &c.; (one of the figures—Percy, first Earl of Northumberland).

66 The ST. HELENS CROWN GLASS COMPANY,
St. Helens, Lancashire—Manufacturers.

A window composed of national emblems. Designed by Luke Limner. This window is represented in the accompanying Plate 90.

Statue window, with figure for a niche in classical drapery.

Window, in colours, with subject—"Michael casting out the great Dragon."

Statue window, with Gothic figure for a niche.

Ornamental window, with Grecian ornament.

Each window is a single plate of glass.

[These windows, executed in a single piece of glass, are deserving of notice, as presenting a specimen on the largest scale of applying design by heat to glass.]

67 HOWE, J. G., 4 *Cumberland Place, New Road*—
Designer and Executor.

Stained-glass window, after the style of the 13th century, representing, in three medallions, celebrated Scripture subjects.

68 GAUNT, T., 4 *Springfield Place, Leeds*—Designer.

A painted window; subject, the Four Evangelists. The process employed in preparing the specimen presents a cheap and durable method of producing windows for churches.

69 HEDGELAND, GEORGE, *Grove Place, Lisson Grove*—
Designer.

Stained and painted glass of the decorated period of Gothic architecture.

70 HALL & SON, *Bristol*—Manufacturers.

Ornamental leaded stained-glass window.

71 TOMS, JOHN, *Hijh Street, Wellington, Somerset*—
Manufacturer.

Painted window; subject—Mary Magdalen; generally adapted from a picture by Timotio Viti.

The novelty consists in the adaptation of the natural forms of plants to the decorative portions of a mosaic glass painting.

72 GIBSON, J., 89 *Clayton Street, Newcastle-upon-Tyne*—
Designer.

Painted windows: in black and white (*en grisaille*), of early Norman character, with interlacing fillets of ruby and green, forming geometrical tracery, with an enamelled border; a free imitation of a decorated window in St. Martin's cum Gregory, York; early Norman, in the centre, "the Nativity," and other subjects; representing St. Margaret (after John van Eyk) on a pedestal; of early Norman character, consisting of roundlets, with sacred subjects; and of the decorated style, with enamelled canopies and niches, containing the figures of St. Agnes and St. Helena, on pedestals, &c.

73 WAILES, WILLIAM, *Newcastle-upon-Tyne*—
Designer and Manufacturer.

Windows of perpendicular and decorated periods of architecture.

Part of window in decorated style, for east front of Ripon cathedral; figure in perpendicular period.

Part of window in decorated period, with grisaille ground.

Norman memorial window, with grisaille ground; decorated window, with grisaille.

Norman window; part of window in transition style, from Norman to early English.

Specimens of early English grisaille.

Parts of window for St. James's Church, Piccadilly, London—cinque-cento style.

Designs of windows, in various styles.

74 CLAUDET & HOUGHTON, 89 *High Holborn*—
Producers.

Painted glass for three compartments of a window, viz., the figures of St. Peter, St. Paul, and the Saviour, with architectural canopies and back grounds, all from original designs.

75 GIBBS, ISAAC ALEXANDER, 2 *Harwood Place, Camden Town*—Designer and Producer.

Norman window. Subjects taken from the life of St. Peter, treated in strict accordance with glass of the Norman period.

Decorated Gothic compartments—Figure of St. John, and other Scripture subjects.

Four compartments of highly-finished pictorial glass, forming a Scripture subject.

76 MAYER, GEORGE, 314A *Oxford Street*—Designer
and Painter.

A stained-glass window, representing Saint George and the dragon, standing under a Gothic canopy of the decorated period.

77 JACKSON, E. & W. H., 315 *Oxford Street*—
Proprietors.

The Royal Arms of England, painted on glass.

78 BALLANTINE & ALLAN, *George Street, Edinburgh*—
Designers and Manufacturers.

Stained glass, Elizabethan style. Window of entrance hall, Glenormiston. The Glenormiston estate is held direct from the Crown, on condition that the proprietor, when required, shall present the sovereign with a red rose on the festival of St. John. The pictorial part of the window represents the ceremony which, according to local tradition, was performed in 1529, on the occasion of the Scottish monarch passing through Peeblesshire. An heiress of the sixteenth century, supported by a knight, presents the sovereign of the period with a rose. In the background, a retainer displays the banner of St. John. In the upper corners, the legend, "He that tholes o'ercomes."

Stained glass, decorated style: central compartment of chancel window, St. Matthew's, Liverpool, figure of the Saviour with canopy and pedestal.

Panels of ornamental glass, decorated style, and Oriental view.

79 **NEWSHAM, S. J.**, 1 *Hereford Street, Oxford Street*—Designer and Producer.

Painted glass—the Prince of Wales' feathers on a background of purple, showing the rose, thistle, and shamrock, encircled with a green wreath of oak leaves.

80 **BLAND, SAMUEL KING**, 15 *Lisson Grove North, Marylebone*—Designer and Manufacturer.

Enamel painted windows; Roman foliated ornament, adapted to modern decoration.

81 **TOBEY, JOHN DOWNTON**, 10 *Henrietta Street, Manchester Square*—Designer and Producer.

Stained glass.—The royal arms, with garter, crown, supporters, crest, and motto, on a rich diapered ground, with national emblems, surrounded by an ornamental border.

82 **HOADLEY, GEORGE**, 6 *St. James's Place, Hampstead Road*—Manufacturer.

Specimens of painted glass, viz.:—
The Earl Aymer de Valance and his Countess, in the costume of the 13th century.

Group, "Charity," after Sir Joshua Reynolds.
Ancient light, containing a medallion of Henry VIII.
"The Offering of the Wise Men," after Rubens.
"Madonna and Child," after Correggio.
Head of the Saviour, after Carlo Dolci.

83 **ROYAL PATENT DECORATIVE GLASS WORKS**, 21 *Castle Street, Southwark Bridge Road*—Producer.

A stained window of vitrified glass, representing the Adoration of the Wise Men of Bethlehem. Composed and executed by Loussein Cartisser.

Two large windows of ornamental lace-pattern glass, and three large squares for blinds, &c.

The nine windows of the Royal Commission room, in a new style for vitrified decorative glass, representing the initials of Her Majesty and His Royal Highness Prince Albert, with the Royal Crest, enclosed within a wreath of roses, and a border composed of the rose, shamrock, and thistle. In this new application of enamel on glass by mechanical process, the material used for the matt or ground-work is different to that usually employed for the same purpose; it is more even in surface, retains its purity of colour, is not affected by exposure to the atmosphere, and has a semi-transparent appearance, not found in any work of a similar character. It is applicable for churches, museums, picture galleries, panellings, coffered ceilings, skylights, muslin curtains, window blinds, &c. It does not obstruct the light, and adds very materially to the decoration of an apartment. Composed and executed by Joseph Cartisser. The accompanying Plate, 147, represents the design of these windows.

84 **SWINBURNE, R. W. & Co.**, *South Shields*, and *Newcastle-on-Tyne*.

Pressed and coloured plates of glass for church windows. (*North-West Gallery*.)

85 **JAMES, W. H.**, 7 *Ferdinand Terrace, Pancras Vale*—Inventor and Designer.

Window-glass, ornamented by machinery.

86 **LONG, C.**, *King Street, Portman Square*—Manufacturer.

Specimens of engine-turning on glass. Applicable to staircase windows, parlour blinds, conservatories, hall lamps, or to any purpose or situation where a subdued light may be necessary. (*Side of No. 18, Exit Door*.)

87 **BANKART & SONS**, *Red Jacket Copper Works, near Neath, Wales*, and 9 *Clements Lane*—Manufacturers.

Stained-glass window, executed by F. F. Bankart, containing a number of small pieces of glass, united upon plate glass. By this means lead joinings are dispensed with and novel effects produced.

88 **DANBY, J.**, 14 *Halsey Street, Chelsea*—Manufacturer.

Imitations of lacework on plate and other glass, produced without fire; the process is applicable to the largest squares of glass, plain or coloured. The white parts are real ground glass. This process is new.

90 **IRWIN, GEORGE O. M.**, 7 *St. James's Street*—Proprietor.

The duplex decanter.

This decanter is made with a partition in the centre, which divides it into two parts, each having a separate neck, so that different liquids can be supplied simultaneously.

100 **HARTLEY, JAMES, & Co.**, *Sunderland*—Manufacturers.

Patent rough-plate glass of improved surface, $\frac{1}{4}$ th of an inch thick; 30 oz. to the square foot; for ridge-and-furrow roofing of conservatories, factories, and for general purposes. Larger sizes are obtainable in this rough plate than could previously be procured in glass of similar quality of less substance than a quarter of an inch. For conservatories it is considered valuable for its diffusing the light, and requiring no shading to prevent the scorching action of the direct sun-rays, as in the employment of ordinary sheet-glass.

Section of ridge and furrow roof 10 feet span, glazed with the same, in squares 62 by 18 inches.

Models, &c., illustrating the manufacture of crown and sheet glass:—Model of a glass-house, the "cone" being made of glass, with model of an eight-pot furnace, &c.; scale $1\frac{1}{2}$ inch to a foot. Melting pot, full size; specimens in the various stages of manufacture, &c.

Model of a green-house on the ridge and furrow flat-roofed principle: the ridges being formed of single squares without a lap-joint.

Specimen windows of patent rolled coloured glass.

Specimens of stained-glass borders; various kinds of coloured glass, illustrated by a pattern in which no enamel colours are employed.

Specimens of various articles for horticultural and dairy purposes; glass for railway purposes, &c. (*Main Avenue East, South Corner*.)



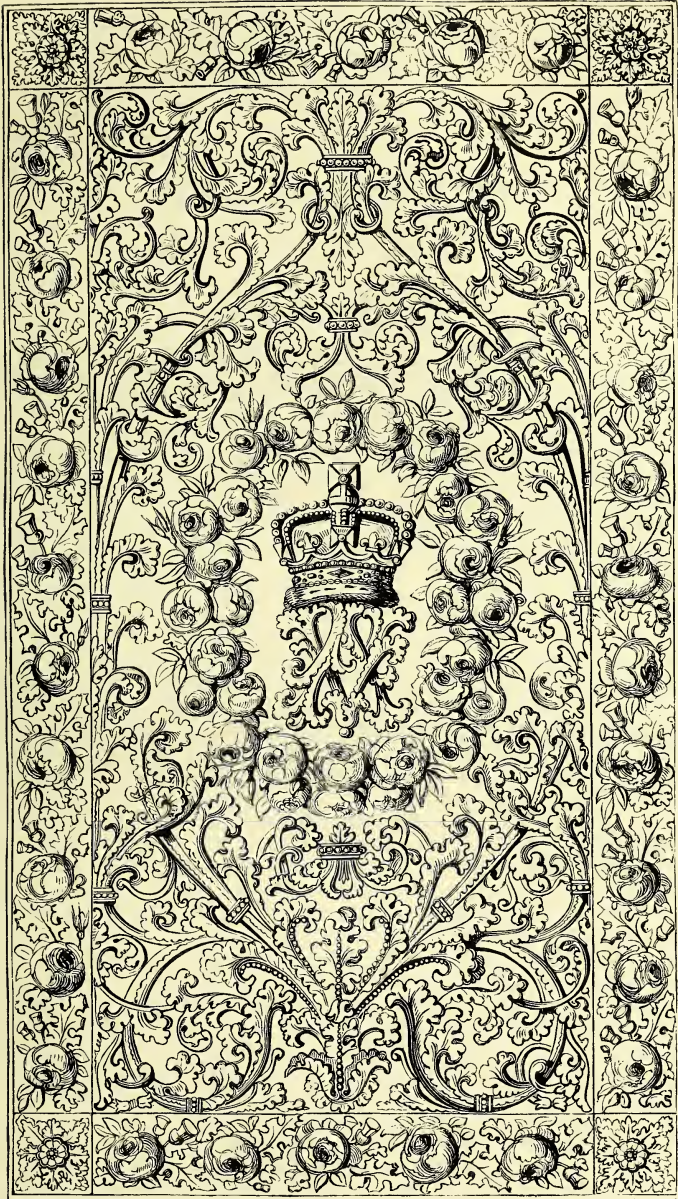

G.P.NICHOLLS.SC

147. ONE OF THE WINDOWS OF THE ROYAL COMMISSION ROOM, IN VITRIFIED DECORATIVE GLASS, EXECUTED BY JOSEPH CARTISSER. ROYAL PATENT DECORATIVE GLASS WORKS.

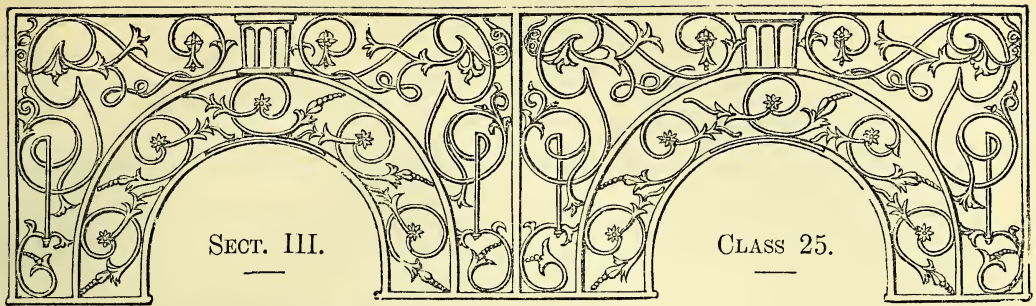

CHINA, PORCELAIN, EARTHENWARE, ETC.

INTRODUCTION.

THE Class to which attention is now directed is one which wears a peculiarly interesting character in this country. To no single individual are those manufacturers who practise the ceramic art in Great Britain indebted so much as to Josiah Wedgwood, whose reputation has become universal. The finer kinds of earthenware which, previous to his era, were made with but indifferent success were, by his efforts, brought to a degree of excellence which has created for them a market almost all over the world. In addition, he produced at the works, founded by him at the village also built by him in Staffordshire, and called Etruria, various kinds of ware applicable to many different purposes. Among these were porcelain biscuit, white and black, a terra cotta, somewhat resembling porphyry in its character, Queen's ware, a variety adapted for table use, and some fine descriptions of porcelainous biscuit. In other countries, the finer descriptions of ceramic productions are produced of a greatly superior character to ours, as at Dresden and Sèvres, but in no other country but Great Britain, is the common earthenware for the ordinary purposes of life, produced either in such quantities, or of such a quality and degree of economy in price.

This Class embraces the following sub-classes:—A. Porcelain, Hard; B. Statuary Porcelain, as Parian, Carrara, &c.; C. Tender Porcelain; D. Stoneware, glazed and unglazed, as Ironstone, or Stone China, Brown Ware, Chemical Utensils, &c.; E. Earthenware of various descriptions, white and coloured; F. Terra Cotta for Vases, Encaustic Tiles, Tesserae, Bricks, &c.; G. Ornamented or Decorated, as articles ornamented on Bisque on the glaze; H. Includes ceramic productions chiefly applicable to architectural purposes.

About sixty Exhibitors appear to represent this Class in the Exhibition. Their position in the Building is in the North Transept Gallery. In this place, the various kinds of ware are arranged on tables and in cases, and furnish material for attentive consideration.

In Class I, several Exhibitors will be found who show the raw material employed in this manufacture, and largely developed naturally in Cornwall, from the decomposition of the rocks of that district. In this Class, the variety of forms communicated generally by the simple but effective instrumentality of the potter's wheel to this material, and its beauty and fitness for use in a perfect state, form a subject for interesting thought. Wedgwood made the first attempt to communicate beauty of form to ordinary objects, and his example is being largely copied in our own time. Of late the application of porcelain to statuary has rapidly extended, and a number of beautiful objects in statuary porcelain are exhibited. Many difficulties of manipulation attend the production of these objects, arising out of the shrinking of the clay when burnt; but, notwithstanding, great delicacy and sharpness of outline are preserved, in the statuettes, and other interesting specimens of different Exhibitors. A curious reproduction of objects, after the antique, arranged in a model of a tomb, afford an excellent illustration of the facility with which these objects can now be manufactured, and so closely resembling the ancient models as to be scarcely distinguishable from them.

The district comprised within that known as the "Staffordshire Potteries," is the largest producing locality in this description of manufacture. The making of earthenware has been conducted in this district for nearly two centuries. Many villages, containing large works devoted to this manufacture, are now thriving here, and supply vast quantities annually of cheap and excellent ware for home use or for exportation. At Stoke-upon-Trent, also, extensive works are carried on. The china of Worcester has long been celebrated for its beautiful quality, and is represented in this Exhibition. Outside the western extremity of the Building, various large objects in common brown-ware, such as pipes, condensers, jars, &c., are arranged.—R. E.

1 MINTON, H., & Co., Stoke-upon-Trent, Staffordshire— Manufacturers.

1. *Dessert Service*, consisting of assiettes montées, round, oval, and triangular baskets, jelly stands, wine coolers, cream bowls, salt cellars, elevated and low comports, perforated china, in turquoise and gold, painted Cupids, flowers and fruit, with Parian figure and ornamental supports: ornaments, gilt and chased, and candlesticks in Parian, gilt, and plates of various patterns.

Porcelain Vases.

2. Large vase, with perforated ornaments, decorated, and finished with or-molu mountings.

3. Pair of Parnassus vases, being a combination of china and Parian; the china in mazarine and gold, and the bas-relief, Apollo and the Muses, in Parian.

4. * Vases, a pair, bleu de roi, and a pair Sèvres green: the grounds, with painted flowers, and raised festoons, gilt.

5. * Pair of vases, with foliage handles, green and gold, and painted festoons of flowers.
6. * Pair of vases, with perforated chain handles, bleu de roi, with painted flowers, and gilt.
7. * Set of three jardinières, green and gold ribbons, and painted groups of flowers.
8. * Pair of festoon vases, green ribbons, pink and gold, spotted ground, painted flowers and birds, gilt.
9. * Pair of egg-form vases, turquoise ribbons, painted wreaths of flowers and laurel on one side: groups of flowers on the reverse, and gilt.
10. * Pair of round perforated vases, blue and gold spotted ground, painted festoons, and wreaths of flowers tied with ribbons and gilt.
11. * Pair of vases, turquoise and painted wreaths of flowers, with festoons of oak, laurel, &c., gilt.
12. * Rope festoon vases, mazarine and Sèvres green grounds, and gilt.
13. * Pair of Harewood bottles, mazarine ground, and gilt.
14. * Pair of jardinières, mazarine ground, painted wreaths of flowers, &c., gilt.
15. * Pair of husk vases, mazarine stripes, and gilt.
16. * Pair of rope festoon vases, Sèvres green ground, painted festoons of oak and laurel, and wreaths of flowers, bird in compartment, and gilt.
17. * Pair of beaded vases, turquoise ground, and painted flowers, gilt.
18. * Pair of beaded vases, with a turquoise ground, painted pink, Cupids in compartments, and gilt.

Porcelain Inkstands, Seaux, Card Trays, &c.

19. Inkstand, green and gold diamonds, painted birds, in compartments, and roses in small compartments, gilt.
20. Cross-bar inkstand, turquoise cross-bars, painted wreaths of flowers, crossing turquoise, and gilt.
21. Inkstand, Sèvres green cross-bars, painted wreaths of flowers, and gilt.
22. Pair of wine coolers, mazarine ground, painted Sèvres groups, in compartments, and gilt.
23. Pair of seaux, turquoise diamonds, painted birds in compartments, and roses in small compartments, and gilt.
24. Pair of seaux, mazarine ground, painted flowers and fruit in compartments on one side, and birds on the reverse, gilt.
25. Pair of seaux, turquoise and stripes, painted flowers and fruit in compartments on one side, and birds on the reverse, and gilt.
26. Pair of seaux, Cupids painted in pink, and gilt.
27. Card tray, painted landscape, figures and cattle, gilt.
28. Small hexagon card tray, Sèvres green ground, painted wreaths of flowers, tied with ribbons, and gilt.
29. Oval tray, painted sprays of wild flowers, and gilt.
30. Perforated flower stand, on claws, turquoise and gold, and painted flowers.
31. Pair of candlesticks, with figures in the costume of the time of Louis XV.

Porcelain Cups and Saucers, Dessert Plates, Dinner Plates, &c.

32. A variety of tea-cups and saucers, dessert and dinner plates, and déjeuner sets.

Parian Figures, Vases, &c.

33. Equestrian figures of Amazon (after Fauchère), and Theseus; two groups of Children with Goat.
34. Statuettes:—Dorothea, Miranda, Clorinda, Una and the Lion, Triton and Nautilus, the Babes in the Wood, by John Bell. The Infant Neptune, by H. J. Townsend. The Distressed Mother, from the statue by Sir R. Westmacott. Cupid indignant, with pedestal, and festoons of raised flowers. Temperance, Flora.
35. Groups:—Love restraining Wrath (Beattie); Naomi and her Daughters-in-law; the Flight into Egypt.

36. Statuettes:—Mercury (after Thorwaldsen); Shakspeare, by John Bell; Sir Robert Peel; the Prince of Wales.
37. Busts of Michael Angelo and Raphael, by John Bell.
38. Statuettes:—Ariadne on a Panther (after Daneker); Atala and Chactas.
39. Candlesticks, with figures in the costume of the time of Louis the Fifteenth.
40. Flower stand, group of hunters, with perforated basket.
41. Set of chessmen, by John Bell.
42. Chimney-piece, in Parian.
43. Ewers with stands, after Cellini.
44. Vases, with embossed festoons and ornaments, gilt.
45. Roman Cippus vases, embossed birds and foliage, and turquoise ground.
46. Sneyd vase, with olive-branch ornament.
47. Pair of vases; one with an embossed ornament of the oak, and the other of the ivy.
48. Pair of Piranesi vases.
49. Perforated flower-stand, with festoons of raised flowers.
50. Pair of Pompeian cups.
51. Pair of cups, Sutherland and companion.
52. Group of raised flowers, with a Cupid in the centre, and a twisted dolphin support.
53. Dolphin tazzas.
54. Brackets with figures.
55. Pair of brackets, after Michael Angelo.
56. Pair of eagle brackets.
57. Pair of mask-head brackets.
58. Candlesticks, and pianoforte candlesticks, in the style of Boule, gilt.
59. Variety of jugs, butter coolers, &c.

Earthenware Fire-place Slabs.—Earthenware enamelled Tiles, Flowerpots, &c.

60. A variety of fire-place slabs, enamelled tiles, flowerpots and stands, and garden seats.
61. Tea urn and tea-pot stands.
62. Earthenware dinner plates, ewers and basins, enamelled and printed.
63. Series of chemical utensils, in hard porcelain.
64. Raw materials used in the manufacture and in the ornamenting of porcelain and earthenware.
65. Fired specimens of colours.
66. Earthenware, in the different stages of its manufacture.

Tiles, Terra Cotta, and Vases, &c., in imitation of Majolica Ware.

67. Encaustic and other tiles, for pavements, and for lining walls.
68. Pillars of enamelled bricks.
69. Large vase, designed by Baron Marochetti, in terra cotta. The figures in bas-relief, represent Neptune and Amphitrite on one side, and Sirens restraining Boreas on the other.
70. Flowerpots in terra-cotta, with Parian bas-reliefs (after Thorwaldsen), representing the four Seasons, introduced in panels.
71. Figure of Galatea with Cupid and a dolphin, for a conservatory fountain.
72. Winecoolers of porous ware; ornamented with views, and festoons of vine leaves and grapes, in buff; with a wreath of vine leaves, &c.; with festoons of vine leaves and grapes, and coloured in the majolica style; with wreath of vine leaves, &c., and coloured.
73. Roman Cippus vases, dark-blue ground, and coloured foliage, &c.
74. Variety of flowerpots and stands, coloured in the majolica style, &c.

[The clays used by the potter are those of Cornwall, Devon, and Dorset. The Cornish is the best quality, and is technically termed by potters "China clay;" it enters very extensively into the composition of the best kind of ware. It is the decomposed felspar of the granite, and is prepared by the clay merchants themselves in Cornwall, prior to its being sent to the potteries. Huge masses of white granite abound in Cornwall, which is in some parts found partially decomposed; and when this is the case, the mineral is raised and prepared for the potter's use, it having been discovered by Mr. Cook-

* The cases, &c., marked with an asterisk are all after old Sèvres models, with new decorations after the old Sèvres style.



35. STATUETTE, MR. COPLAND.

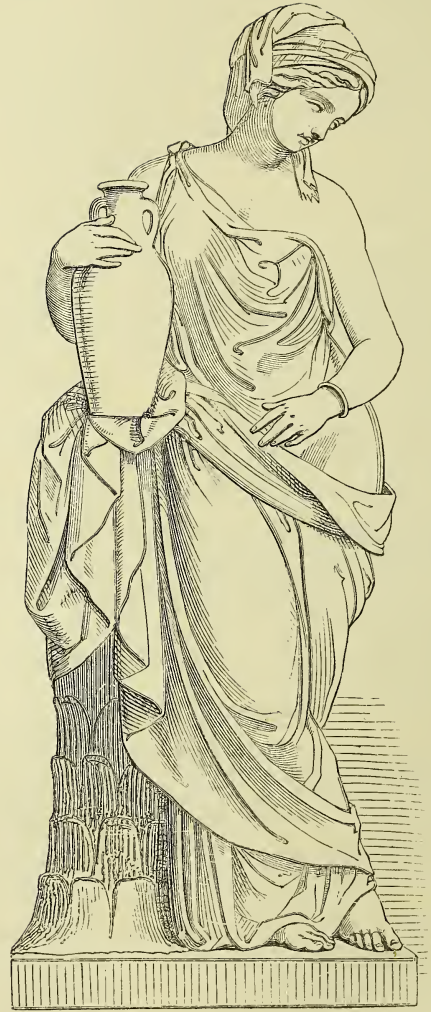

36. STATUETTE, MR. COPLAND.

worthy, of Plymouth, in 1765, that it furnished the true kaolin, and also the "petunsee" of the Chinese.

The following is the method of preparation:—The stone, having been broken up by a pickaxe, is laid in a stream of running water: the light argillaceous parts are thus washed off and kept in suspension; the quartz and mica being separated are allowed to subside near the place where the stone was first raised. At the end of these rivulets are a kind of catchpools, where the water is at last arrested, and time allowed for the pure clay with which it is charged to form a deposit, which being effected, the water is drawn off; the clay is then dug up in square blocks and placed upon a number of strong

shelves called "linnees," so fitted as to allow a free circulation of air, in order that the clay may be properly dried. Thus prepared it is extremely white, and, when crushed, forms an impalpable powder. It is forwarded to the potteries under the name of china-clay.—T. B.]

2 COPELAND, WILLIAM TAYLOR, *Stoke-upon-Trent, and 160 New Bond Street—Manufacturer.*

Works in porcelain statuary:—

Group of Ino and the Infant Bacchus, by J. H. Foley, R.A., from the original model in the possession of the Earl of Ellesmere. This group is represented in the annexed engraving.

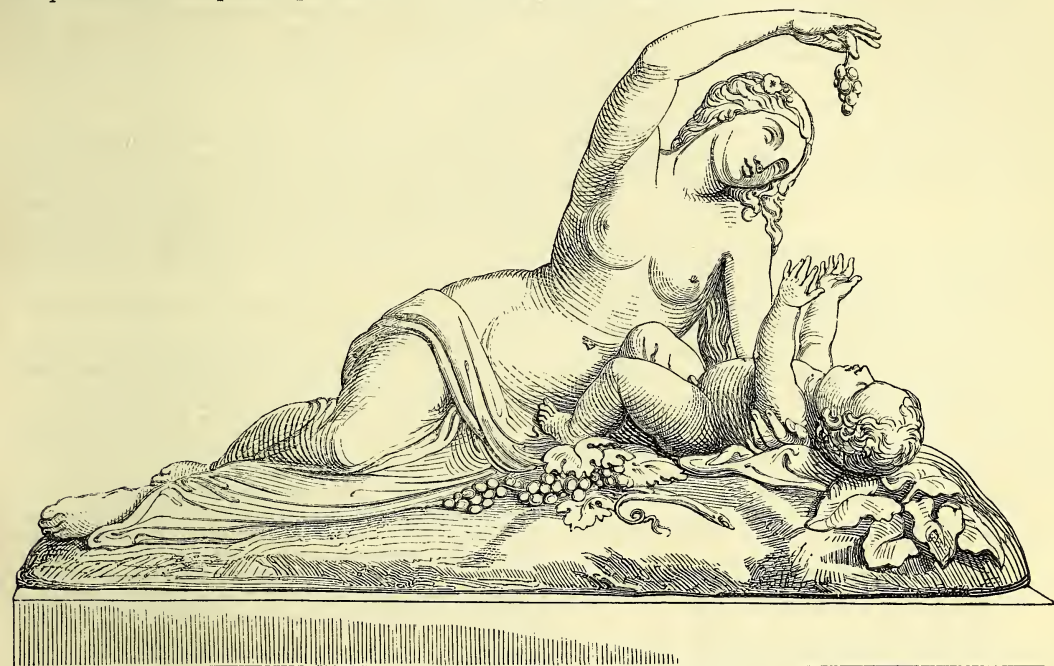

Copeland's Porcelain Group, "Ino and Bacchus."

Group of The Prodigal's Return, by W. Theed. This group is represented in the accompanying Plate 35.

Sabrina, by W. C. Marshall, R.A. See Milton's Comus.

The Goatherd, by the late J. R. Hyatt, R.A., from the original marble in the possession of the Duke of Sutherland. Venus, by John Gibson, R.A.

Sappho, by W. Theed, from the original marble.

Equestrian statuette of Emanuel Philibert, Duke of Savoy, by the Baron Marochetti. Rebecca, by W. Theed. This statuette is shown in the accompanying Plate 36.

The Indian Girl and the Nubian Girl, by Cumberworth.

Head of Juno, life size, from the antique. The Astragali Players. The Girl with Scorpion.

Innocence, by J. H. Foley, R.A., executed for the Art Union of London.

Narcissus, by John Gibson, R.A., executed for the Art Union of London.

The Dancing Girl Reposing, by W. C. Marshall, R.A., executed for the Art Union of London.

Lady Godiva, by J. P. M'Bride, executed for the Art Union of Liverpool. See Tennyson's Godiva.

Sir Walter Scott; reduced copy by John Steel, R.S.A., from the original colossal statue on the Calton Hill, executed for the Edinburgh Association for the Promotion of the Fine Arts.

Group of Graces, and group of Cupids, as Kanephoroi.

H.R.H. the Princess Alice, as Spring.

H.R.H. the Princess Royal, as Summer.

H.R.H. the Prince Alfred, as Autumn.

H.R.H. the Prince of Wales, as Winter.

The above illustrative series from the original models, executed by Mrs. Thorneycroft, for the Queen.

"The Bride" and "The Sea Nymph."

Group of "Paul and Virginia," by Cumberworth.

Sir Robert Peel, by Westmacott.

Lord George Bentinck, by Count D'Orsay.

Jenny Lind, by Durham. Shakspeare.

The Lady Clementina Villiers, by M'Donald.

H.R.H. the Princess Helena, by Mrs. Thorneycroft.

Duke of Wellington, by the Count D'Orsay.

Duke of Sutherland, by Francis.

Pair of Cellini vases and pedestals.

Group of "The Return from the Vintage," consisting of seven figures.

[The articles under the head of Statuary Porcelain, including Parian, Carrara, &c., are produced by "casting." As the most direct method of illustrating this process, let us suppose the object under review to be a figure or group, and this we will assume to be two feet high in the model. The clay, which is used in a semi-liquid state, about the consistency of cream, and called "slip," is poured into the moulds forming the various parts of the subject (sometimes as many as fifty): the shrinking that occurs before these casts can be taken out of the mould, which is caused by the absorbent nature of the plaster of which the mould is composed, is equal to a reduction of one inch and a half in the height. These casts are then put

together by the "figure-maker;" the seams (consequent upon the marks caused by the subdivisions of the moulds) are then carefully removed, and the whole worked upon to restore the cast to the same degree of finish as the original model. The work is then thoroughly dried, to be in a fit state for firing, as, if put in the oven while damp, the sudden contraction consequent upon the great degree of heat instantaneously applied, would be very liable to cause it to crack; in the process it again suffers a further loss of one inch and a half by evaporation, and it is now but one foot nine inches. Again, in the "firing" of the bisque oven, its most severe ordeal, it is diminished three inches, and is then but eighteen inches high, being six inches, or one-fourth less than the original. Now, as the contraction should equally affect every portion of the details of the work, in order to realize a faithful copy, and as added to this contingency are the risks in the oven of being "over-fired," by which it would be melted in a mass, and of being "short-fired," by which its surface would be imperfect, it is readily evident that a series of difficulties present themselves which require considerable practical experience successfully to meet.

The moulds are made of plaster of Paris, which, when properly prepared, has the property of absorbing water so effectually that the moisture is extracted from the clay, and the ware is enabled to leave the mould, or "deliver" with care and rapidity. Prior to use, the plaster (gypsum) is put into long troughs, having a fire running underneath them, by which means the water is drawn off, and it remains in a state of soft fine powder; and if its own proportion of water be again added to it, it will immediately set into a firm compact body, which is the case when it is mixed to form the mould.

The following are the degrees of temperature in which the different branches work:—

Plate-makers' hot-house	108° Fah.
Dish-makers' hot-house	106 "
Printers' shop	90 "
Throwers' hot-house	98 "

The branches against which the temperature of the "hot-house" is placed, require that heat for drying their work and getting it off the moulds. The outer shops in which they work may be from five to ten degrees less.—T. B.]

Variety of vases, garden pots, and articles of ordinary use.

Ancient font, from the original in Winchester Cathedral.

The Portland jug. Lily of the valley jug. The acanthus garden vase.

Fine porcelain:—

A vase of Etruscan form, with chased and burnished gold ornaments, on a blue ground, decorated with floral wreaths, enamelled, in colours, &c., with pedestal 40 inches high.

A great variety of ornamental vases, chased and gilded, with various designs in enamels and otherwise.

Verulam bottles: ribbon wreath, and group of flowers; turquoise ribbon, and group of flowers; and gold lattice. Large tripod, for flower-stand, blue ground, decorated in chased and burnished gold.

The Dove Tazza, and pedestal. The birds and embossments in solid gold, chased, turquoise ground, and floral wreath, &c. Another with royal blue grounds, the details of ornament in gold and silver.

Pair of vases, rose ground, chased gold panels, with musical emblems and flowers.

Pair of Armada bottles, with jewel design, in enamels and gold, on royal blue ground.

Large vases, 28 inches high, by 27 inches wide, royal blue ground, and Greek ornaments in chased and burnished gold.

Warwick vase, 24 inches high, and 28 inches wide, royal blue ground, in chased and burnished gold.

Pelican pedestal, 52 inches high, decorated in blue, buff, and gold.

Pair of ice-pails, with wreath of the vine, enamelled; a pair, turquoise ground, gold panels of flowers and fruit; and a pair cyclamon ground, chased, gold design, ornamented with jewels and vignettes.

Pair of vases, with wreaths of orchidaceous plants.

Variety of other vases, jardinières, flower-stands, &c.

Circular plateau for table (fine porcelain), turquoise grounds, gold ornaments, chased and burnished, with vignettes of flowers, Watteau subjects, &c.

Porcelain table, cyclamon ground (new tint), with chased gold panels, Watteau vignettes and wreaths, and groups of flowers. Another, with borders in chased and burnished gold, on blue ground, and festoons of convolvulus.

Circular plateaus for table tops, including design, after Raphael, on gold ground. Ribbon wreath, ornamented with jewels and garland of jasmine. Blue panels, chased gold ornaments, groups, and wreaths of flowers and vignette landscapes. Chased and burnished gold borders, and a floral wreath of the natural size. A cyclamon ground, scroll border in chased gold with a landscape in the centre.

Various panels of fine porcelain, enamelled and gilt, for urn and flower-stands.

Panels with cyclamon ground, with a Watteau vignette and gold panels chased and burnished. Panels with turquoise ground and design in similar style.

Several panels of various designs, intended to be mounted in furniture, &c. Semi-porcelain slabs for the top and the door panels of a dressing-table, with rustic trellis and wreath of ipomeas.

Pair of slabs, in the Pompeian style; the figures in the centre panel are on blue ground; the borders are enamelled and gilt. Another pair of similar design, with blue, white, and chocolate grounds.

Slab 44 inches by 24 inches for a console or dressing-table; it has Greek borders in blue and white; the group of figures is from Flaxman: it is furnished with outlines and gold enrichments. Another Pompeian design, black and fawn.

Pair of slabs, with rustic panels and trails of sweet pea, &c. Another pair, in chased and burnished gold on blue and chocolate grounds.

Specimens of slabs for shutter and Dado panels, executed for Her Grace the Duchess of Sutherland.

Specimens of slabs with pink ground, gold fleur-de-lis, and silver diapering—with blue ground, similarly ornamented—with cyclamon ground, the design being in chased and burnished gold. Slab with renaissance design, embossed in chased and burnished gold on blue ground. An embossed scroll, chased and burnished gold, on white and on cyclamon grounds. Fleur-de-lis in silver, on blue ground with gilt borders; and fleur-de-lis in raised gold on cyclamon ground. A slab 50 inches by 28 inches, enamelled and gilt.

A variety of coving-slabs for fire-places:—A jewel design, coloured in enamels and gold on a blue ground. A cyclamon ground of similar style. Lavender and green styles, with buff ground and chased gold panels. Raphaellesque design, with a foliated scroll on the top and bottom panels, enamelled in tints, with a group of figures in the centre panel, on a black ground with gold enrichments. Mosaic design, enamelled and gilt. Mosaic design on gold grounds, the figures on blue, and the border enriched in chased and burnished gold. Pompeian style with white borders, and coloured figures on red ground. Alhambresque, enamelled design. Etruscan style in black and fawn, and blue and white. Grecian style in white and gold. Gold line panel, with ornamented corners in burnished gold. An indented Moresque design, emblazoned in colours and gold. Indented Moresque designs, variously enamelled and gilt. Wreaths of flowers

on white. Studies of orchids. A rustic panel, with trail of ipomeas. A pink and buff style, with chased gold panel and group of flowers. Several other slabs and panels of various designs, &c.

Specimens of fine porcelain. Dessert plates with scroll borders in chased and burnished gold on a blue ground : in the inner and outer borders the royal initials and coronet are introduced; and the royal arms in the centre. A jewel design on cyclamon ground (double tint), emblazoned in enamels and gold, with the arms of His Grace the Duke of Sutherland. A crimson ground, containing the arms of His Grace the Duke of Wellington. Cyclamon ground, with the arms of His Grace the Duke of Devonshire.

Dessert plates with borders in raised and burnished gold on blue ground, with wreaths of roses, &c.; also a pierced centre-piece and comports in similar style.

Specimens of dessert plates, with an Alhambresque border in raised and chased gold on various coloured grounds, with Spanish views in the centre. Chased and burnished gold panels and rosette, with vignettes of humming-birds; and royal blue and turquoise grounds.

Specimens of plates ornamented with various wreaths of flowers. The border of jewels in coloured enamels, and gilt on green, rose, and royal blue grounds. Chased gold panels, with groups of fruit and wreaths of flowers; the grounds being royal blue, green, rose, and blue. A perforated border, with raised gold panels on cyclamon, and other grounds; there are wreaths of flowers and musical emblems in the centre.

Dessert plates, the ground of a green colour; central panels of birds, fruit, and flowers. Chased gold panels, with groups of flowers, birds, and a cyclamon ground.

Specimens of Gothic pierced plates, with a chased gold border, and a wreath of blossoms and fruit in the centre.

Dessert plates containing studies of various fruits in the centre; the border consists of the foliage and blossom pertaining to each fruit. A blue ribbon wreath enriched with jewels enamelled in colours and gold, and a wreath of white jasmine. A cyclamon and yellow jasmine. A turquoise and rose wreath. A ribbon design, on a raised gold diapered ground, with a wreath of flowers, &c. An embossed design, variously enamelled and gilt. A royal blue panel, with chased gold ornament, and groups of fruit and flowers. Example of the renaissance style, on blue and French white grounds, gilt and chased with flower groups and wreaths on chocolate ground, with the royal initials in the centre. A cyclamon and crimson ground, with flowers in gold, and the initials of His Grace the Duke of Sutherland in the centre.

Several dessert samples of various designs enamelled, painted, and gilt.

[Enamel colours are metallic oxides incorporated with a fusible flux: gold precipitated by tin furnishes the crimson, rose, and purple; oxides of iron and chrome produce reds; the same oxides yield black and brown, also obtained from manganese and cobalt; orange is from oxides of uranium, chrome, antimony, and iron; greens from oxides of chrome and copper; blue from oxides of cobalt and zinc. The fluxes are borax, flint, oxide of lead, &c. They are worked in essential oils and turpentine; and a very great disadvantage under which the artist labours is, that the tints upon the palette are in most cases different to those they assume when they have undergone the necessary heat, which not only brings out the true colour, but also, by partially softening the glaze and the flux, causes the colour to become fixed to the ware. This disadvantage will be immediately apparent in the case where a peculiar delicacy of tint is required, as in flesh tones, for instance. But the difficulty does not end here, for, as a definite heat can alone give to a colour a perfect hue, and, as the colour is continually varying with the different stages of graduated heat, another risk is incurred—that resulting

from the liability of its receiving the heat in a greater or less degree, termed “over-fired” and “short-fired.” As an instance of its consequence we will cite rose colour or crimson, which, when used by the painter, is a dirty violet or drab; during the process of firing it gradually varies with the increase of heat, from a brown to a dull reddish hue, and from that progressively to its proper tint. But if by want of judgment or inattention in the fireman, the heat is allowed to exceed that point, the beauty and brilliancy of the colour are destroyed beyond remedy, and it becomes a dull purple. On the other hand, should the fire be too slack, the colour is presented in one of its intermediate stages, as already described; but in this case extra heat will restore it. Nor must we forget to allude to the casualties of cracking and breaking in the kilns by the heat being increased or withdrawn too suddenly, a risk to which the larger articles are peculiarly liable. These vicissitudes render enamel painting in its higher branches a most unsatisfactory and disheartening study, and enhance the value of those productions which are really successful and meritorious.—T. B.]

Examples of fine porcelain :—A variety of cups and saucers of different forms and designs, enamelled and gilt. Examples of cabinet cup-stands, in various styles of decoration. Specimens of printing in gold.

Examples of door furniture, finger-plates, knobs, &c.

Soup-tureen, with a border in the Greek style on blue and chocolate grounds, chased and burnished gold, &c. A sauce-tureen; a covered dish and plates. Soup-tureen, with a honeysuckle border in chased and burnished gold on blue. A sauce-tureen; a covered dish and plates. Various specimens of table-ware in different styles of ornament. A collection of ewers and bowls in fine porcelain, of various enamelled and gilt designs, for toilet services.

Ewer and bowl, ornamented with wreaths of fuschias. Executed for her Grace the Duchess of Sutherland.

Specimens of “Bat printing” on the glaze, and of tinting.

[There are two distinct methods of printing in use for china and earthenware, one is transferred on the “bisque,” and is the method by which the ordinary printed ware is produced, and the other is transferred on the glaze. The first is called “press printing,” and the latter “bat printing.” The engraving is executed upon copper plates, and for “press” printing, is cut very deep, to enable it to hold a sufficiency of colour to give a firm and full transfer on the ware. The printer’s shop is furnished with a brisk stove, having an iron plate upon the top, immediately over the fire, for the convenience of warming the colour while being worked, also a roller, press, and tubs. The printer has two female assistants called “transferrers,” and also a girl, called a “cutter.” The copper plate is charged with colour, mixed with thick boiled oil, by means of a knife and “dabber,” while held on the hot stove plate, for the purpose of keeping the colour fluid; and the engraved portion being filled, the superfluous colour is scraped off the surface of the copper with the knife, which is further cleaned by being rubbed with a “boss,” made of leather. A thick firm oil is required to keep the different parts of the design from flowing into a mass, or becoming confused, while under the pressure of the rubber in the process of transferring. A sheet of paper, of the necessary size and of a peculiarly thin texture, called “pottery tissue,” after being saturated with a thin solution of soap and water, is placed upon the copper plate, and being put under the action of the press, the paper is carefully drawn off again (the engraving being

placed on the stove), bringing with it the colour by which the plate was charged, constituting the pattern. This impression is given to the "cutter," who cuts away the superfluous paper about it; and if the pattern consists of a border and centre, the border is separated from the centre as being more convenient to fit to the ware when divided. It is then laid by a transferrer upon the ware, and rubbed first with a small piece of soaped flannel to fix it, and afterwards with a rubber formed of rolled flannel. This rubber is applied to the impression very forcibly, the friction causing the colour to adhere firmly to the bisque surface, by which it is partially imbibed; it is then immersed in a tub of water, and the paper washed entirely away with a sponge; the colour, from its adhesion to the ware, and being mixed with oil, remaining unaffected. It is now necessary, prior to "glazing," to get rid of this oil, which is done by submitting the ware to heat in what are called "hardening" kilns, sufficient to destroy it and leave the colour pure. This is a necessary process, as the glaze being mixed with water, would be rejected by the print, while the oil remained in the colour.

The "bat printing" is done upon the glaze, and the engravings are for this style exceedingly fine, and no greater depth is required than for ordinary book engravings. The impression is not submitted to the heat necessary for that in the bisque, and the medium of conveying it to the ware is also much purer. The copper plate is first charged with linseed oil, and cleaned off by hand, so that the engraved portion alone retains it. A preparation of glue being run upon flat dishes, about a quarter of an inch thick, is cut to the size required for the subject, and then pressed upon it, and being immediately removed, draws on its surface the oil with which the engraving was filled. The glue is then pressed upon the ware, with the oiled part next the glaze, and being again removed, the design remains, though, being in a pure oil, scarcely perceptible. Colour finely ground is then dusted upon it with cotton wool, and a sufficiency adhering to the oil leaves the impression perfect, and ready to be fired in the enamel kilns.—T. B.]

Ornaments for the dessert table:—A group of Graces, in chased and burnished gold, supporting a basket. A group of Cupids. Four Cupids representing the Seasons: the ornaments in turquoise and gold. Pierced baskets, and dolphin stands, for holding fruit, bon-bons, &c.

Various specimens of enamelled and gilt porcelain trays for dessert and for decanter tables. Specimens of decanter-stands. Some varieties of decorated tazza.

Two wedding plateaux for supporting a bride cake: containing appropriate mottoes, and entwined wreaths of orange blossom and passiflora. Another plateau with an enamelled and gilt wreath of orange and passiflora of the natural size.

Specimens of earthenware:—Common printed ware for table and toilet services. Specimens of white earthenware. An enamelled bath, of Etruscan design.

Examples of the "Atmopyre," or gas stove, enamelled and in the Pompeian style.

Specimens of fine crystal glass, cut and engraved, intended for dessert-services, table-glass and lustres.

3 MASON, CHARLES, *Longton, Staffordshire*—Designer, Manufacturer, and Patentee.

Specimens of patent ironstone china.

Garden seats of a mixed Anglo-Indian and Japanese pattern, representing an old dragon, in raised enamel on a gold ground.

Garden seats of an Anglo-Chinese pattern, on a sea-green ground, with raised solid flowers, and gilt panels.

Fish-pond bowls, of Anglo-Chinese pattern; Gog and Magog, an Anglo-Indian pattern: the Water Lily, an Anglo-Japanese pattern.

Jars with raised enamel Mandarin figures, and sea-dragon handles. Large jars and covers of Anglo-Indian pattern. There are also some open jars. Jars covered; dragon handles of Anglo-Indian and Anglo-Japanese patterns, with raised solid flowers, &c.

Specimens of plates in the oriental style of pattern, on registered shapes, and Anglo-Japanese. Three jars and covers, with Anglo-Indian grounds. A plate, a dish, a tureen, a covered dish, a tall coffee-cup and saucer, and a sugar-basin, made of the white patent ironstone china, as used in the hotels of the United States of America.

Jugs of old Indian, Japanese, and gold patterns, of the original shape; also Anglo-Indian and melon pattern; with oriental figures and gold ornaments. Ewer and basin, and mouth ewer and basin, with oriental figures, and a rose border.

Jars:—the old India crackle, with India red grounds. A breakfast cup and saucer.

A monumental tablet, made of ironstone, and lettered under the glaze.

Jugs, showing various patterns in Bandanna ware. Toilet ewers and basins. Antique jugs of Japanese pattern, and gold ornaments. Red and gold paint jars. Zig-zag beakers, on bronze. Table-ware of a Japanese pattern in blue, red, and gold.

4 KENNEDY, WILLIAM SADLER, *Burslem, Staffordshire*—Manufacturer.

Articles in china and earthenware:—Mortice-lock furniture for doors of drawing-rooms, &c., with decoration, in burnished gold, flowers, &c.; finger-plates; bell furniture, shutter-knobs, &c., in same style; hall-door knobs; drawer-knobs, and knobs for all descriptions of cabinet-work; and figures for numbering houses.

5 RIDGWAY, JOHN, & Co., *Cauldon Place, Staffordshire* Potteries—Manufacturers.

English porcelain table service—border, coral and gold; centre, elaborate coat of arms of the united families of Ricardo and Duff; also, part without the arms.

Table-service, British wild flowers, Dresden style; border, embossed and gold. This table-service is represented in the cut on the opposite page.

Table service, same as last, with Grosvenor round covered pieces, marone and buff ground, gold, and star centre.

Table-plates of various patterns, gilt, chased, and ornamented.

Tea and coffee service, azure and gold, with gold star. This service is shown in the cut on the opposite page.

Tea and breakfast service, in various styles. A variety of fancy articles in porcelain.

Improved fine vitreous earthenware, consisting of specimens of the various articles in table and dessert suites; also, toilet and tea ware, coloured and printed.

A group of articles of dessert service is shown in the cut in the opposite page.

Specimens of earthenware for the United States' market.

Lawn fountain, white and gold, playing. Conservatory fountains, for playing. This fountain is represented in the cut on p. 717.

Specimens of staircase, with handrail, balustrade, and steps.

Sanitary vessels, &c., consisting of fountain basins, closets, &c. These vessels are represented in the cuts on p. 717.

The four preceding articles are an entirely new application of pottery.

Superior specimens of hollow bricks and quarries.



Ridgway & Co.'s Table Service.



Ridgway & Co.'s Tea and Coffee Service.



Ridgway & Co.'s Dessert Service.

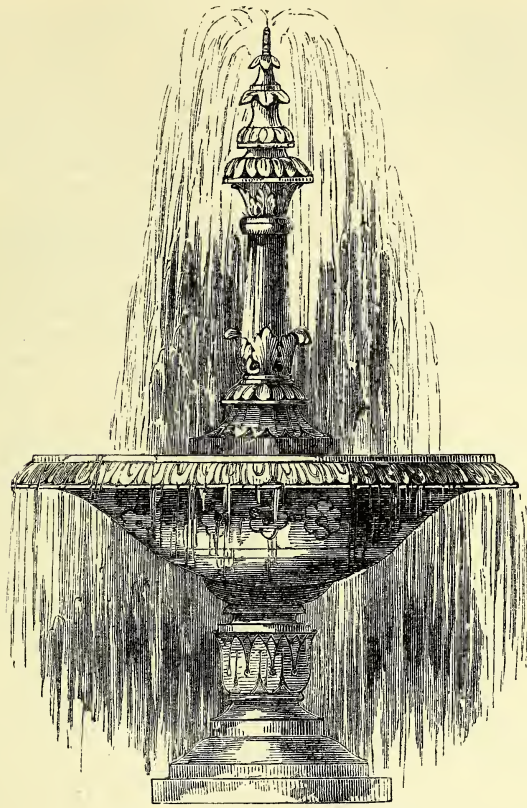

Ridgway & Co.'s Porcelain Fountain.

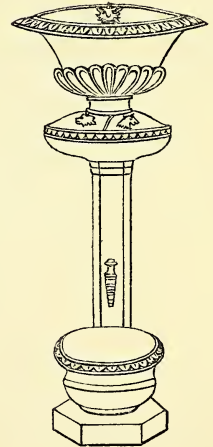
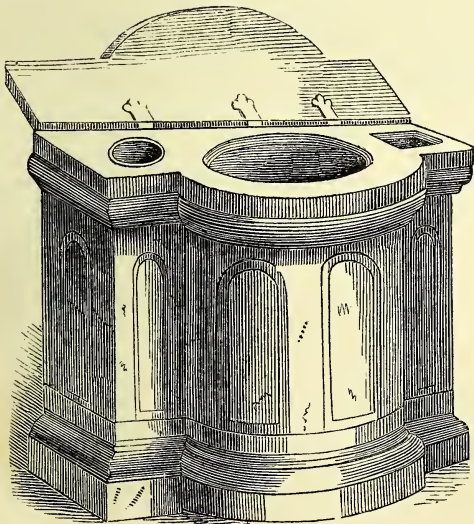

Ridgway & Co.'s Pottery Sanitary Vessels.

5A RIDGWAY, WILLIAM, *Shelton*—Manufacturer.

Vases, bottles, and jars, each ornamented with a different surface, by means of mixed slips, or slop clays, the effect being obtained upon the clay previous to its being moulded into the article required; by an entirely new process.

6 WEDGWOOD, JOSIAH, & SONS, *Etruria, near Newcastle-under-Lyme*—Manufacturers.

Carrara (statuary porcelain).—Figures from the antique—Venus and Cupid, 27 inches high; Cupid, 24 inches

high; infant Hercules, 20 inches by 17; Morpheus, 24 inches long; Venus, 19 inches high; Mercury, 17 inches high; Faun with flute, 17 inches high.

Figures—The Preacher on the Mount; crouching Venus; Nymph at the fountain; Cupid and Psyche, group; Cupid with bow.

Triton candlesticks, right and left (Flaxman).

Busts of Washington; Shakspeare on pedestal; and Venus. Sleeping Boys.

Spill cases, "Bonfire," and set of three "Muses."

Black vase, 8 inches (with the pedestal 9 inches)

"Apotheosis of a Poet." Two vases, 16 inches each, "Water and wine." Various other vases, plain, of different sizes. Lamp and candlestick.

Copy of Portland, or Barberini vase, 10 inches high, dark blue, as the original in the British Museum.

Another in black, with white jasper bas-reliefs. Blue jasper, with white bas-reliefs from the antique:—Vase, 25 inches high, with pedestal 10 inches high, "Sacrifice to Cupid."

Vase, 27½ inches high, "Apotheosis of a Poet."

Vase, with pedestal, 19½ inches, "Ulysses discovers Achilles." Another to match, "Infancy of Achilles."

Vases and pedestals, 21 inches, "Muses." Vases, 12 inches, "Hunting and Hawking," and "The Arts and Sciences."

Various other vases of different sizes, plain and ornamented, including "Hercules at the garden of the Hesperides." "Muses." Bacchanalian subjects, rivers, and arabesque designs.

Flower and incense vases and covers. Alumette club-shape pint jug; temple lucifer box; toy watering can; ring, cigar, and pen trays. Ornamented and Venetian lucifer boxes. Violet baskets; round covered, tooth powder, and lip-salve boxes.

Snuff-boxes. Shaving box, with zodiac ornaments.

Toy garden-pots and stands. Set of chess-men; thirty-four pieces, by Flaxman.

Jugs, various, Florence shape with bas-reliefs.

Octagon and oblong smelling bottles, silver mounted.

Howard and Clarendon tea-pots, pint.

Tea-pot, with aquatic plants, pint. Coffee-pot, Amoy shape, quart.

Pillar-shaped candlestick. Piano candlestick. Taper candlestick.

Jasper.—Cameos of various colours, with white bas-reliefs from the antique.

Black, with red Etruscan figures:—Vases, various, and with inscriptions.

Red terra-cotta, with black bas-reliefs, from the antique:—Choice vases, varied in style, size, and ornament. "Clarendon" toy tea set; comprising tea-pot, sugar, cream, slop bowl, and bread-and-butter plate. Tea-pot, pint, with Egyptian ornaments.

Red porous earthenware:—Wine and butter coolers, various designs. Water bottles and stands. Jug, with cover and stand, quart. Butter cooler, buff porous earthenware.

Chemical earthen and stone ware:—Mortar and pestle, 5 inches; mortar, 1 inch. Evaporating pan, acid proof. White pill tile, graduated. Funnel, fluted; coarse crucible and cover. Voltaic stone-ware trough, with red porous earthenware lining. Porous cylinder, and flat porous cell for voltaic apparatus. Mercury and water baths. Digester. Conical filterer; triangular filter holder.

Plumbers' earthenware:—Closet pans, cream-coloured, and flowing blue printed. Square wash-table, cream-coloured. Long square wash-table, with fittings complete, marbled. Wash-basin, with plug-hole and waste pipe, marbled.

Cream-coloured, or Queen's ware, with enamelled borders:—Etruscan-shaped soup-tureen and stand. Round covered vegetable dish. Dinner plates, in various designs.

Cream-coloured earthenware (Queen's ware):—Plates and dishes. High oval soup-tureen and stand, (by Flaxman). Round and oval soup-tureens. Round Etruscan soup-tureen and stand. Round covered vegetable dish. Herring dish, with embossed fishes. Oval twig pattern fruit basket and stand. Oval quatrefoil-pattern fruit basket and stand. Fruit dishes, various shapes. Quart jugs, Dutch and Roman shapes. Bowls, water-ewers, nursery-lamp. Coffee-biggins, with stove and lamp cup. Milk-boiler and cover. Wine-funnel, with strainer. Egg-beater; blanc-mange moulds; pudding-cups. Egg-shaped pudding-boiler. Round and oval milk pans. Pierced milk-skimmer. White stone tea-pots, arabesque and wheat-sheaf patterns.

Coloured earthenware:—Tea-pot, pint, Rockingham-

coloured, tall and low. Tea-cup and saucer, Bute shape, drab colour. Breakfast bowl and saucer, French shape, drab colour. Oval game pie, cane colour, ornamented. Cambridge ale jug, pint, red-coloured earthenware. Embossed leafage dessert plates and dishes, green glazed. Twig ornamented fruit basket and stand. Two-handled vase, red enamelled Chinese flowers. Jug, half-pint, club shape, black enamelled Chinese flowers. Small plain red garden pots and stands.

[We shall refer, in the first place, to the preparation of the two principal ingredients, flint and natural clay, for the use of the potter, and afterwards to the blending of them. The flint stones are first calcined, and this is effected in a kiln similar to that used for lime-burning. These stones are separated by alternate layers of coal, and the burning usually occupies about twenty-four hours. The flints are then very white and very brittle, and ready to be crushed by the "stamper," a machine composed of upright shafts of wood, six feet long, and about eight inches square, heavily loaded with iron at the lower end, which, by means of applied power, are made to rise and fall in succession on the flints, contained in a strong grated box. It is then removed to the grinding vats, which are from twelve to fourteen feet in diameter, and four feet deep, paved with chert stone, large blocks of which, being also worked round by arms connected with a central vertical shaft, propelled by an engine, become a powerful grinding medium. This peculiar stone is used because of its chemical affinity to the fluid, which, therefore, suffers no deterioration from the mixture of the abraded particles, which necessarily result from the friction, a matter of serious moment. In these vats the fluid is ground in water until it attains the consistency of thick cream, when it is drawn off and conveyed by troughs into the washing chamber. Here it undergoes a further purification; more water is added, and it is kept in a state of gentle agitation, by means of revolving arms of wood, thus keeping the finer particles in suspension while the liquid is again drawn away in pipes to a tank below. The sediment is afterwards re-ground. The cleansing process is not yet complete, for when the fluid has passed into these tanks, to about half their depth, they are filled up with water, which is repeatedly changed, until it is considered sufficiently fine, and free from all foreign matters: it is then fit for use. The clay requires no grinding. It is received from the merchants prepared, and has merely to be mixed with water till it attains the same degree of fluidity as the flints. The next stage is the "mixing," for which purpose the different "slips" (the technical term for the fluid clays, &c.) are successively run off into the blending reservoir, against the inner side of which are "gauging rods," by which the necessary proportion of each material is regulated. The mixture is now passed into other reservoirs, through fine sieves on "lawns," woven of silk, and containing 300 threads to the square inch. A pint of slip of Dorsetshire or Devonshire clay weighs 24 ounces, of proper consistence; of Cornish clay, 26 ounces; and of flint 32 ounces. Finally, the slip is conveyed to a series of large open kilns, heated underneath by means of flues, and about 9 inches deep. The excessive moisture is thus evaporated, and in about 24 hours the mixture becomes tolerably firm in substance. It is then cut into large blocks and conveyed to an adjoining building to undergo the process of "milling." The mill is in the form of a hollow cone, inverted, with a square aperture or tube at the lower part. In the centre is a vertical shaft, set with broad knives. When this shaft is in action (worked by steam power), the soft clay is thrown in, and forced downwards, being alternately cut

and pressed until it exudes from the aperture at the bottom, in a perfectly plastic state, and ready for the hand of the potter.—T. B.]

7 ALCOCK, SAMUEL, & Co., *Burslem, Staffordshire*—Manufacturers.

Designed by Alfred Crowquill:—

- | | |
|------------------------------|---------------------------|
| 1. The Nelson cup. | 11. Dessert plate. |
| 2. The Peace Congress. | 12. Snail ring-holder. |
| 3. Fairy cup, Mischieff. | 13. Butterfly pen-holder. |
| 4. Fairy cup, Curiosity. | 14. Shell pen-holder. |
| 5. Nautilus cup, male. | 15. Cod-fish ash-tray. |
| 6. Nautilus cup, female. | 16. Lily cup and saucer. |
| 7. The Plate of all Nations. | 17. Spill-holder. |
| 8. Dessert centre-piece. | 18. Spill-holder. |
| 9. Sugar-bowl. | 19. Centre for flowers. |
| 10. Water-bottle. | |

Designed by S. W. Arnold:—

- | | |
|---------------------------|---------------------------|
| 20. Madonna jug. | 30. Bacchanalian vase. |
| 21. Madonna vase. | 31. Bacchanalian vase. |
| 22. Cupid and Psyche jug. | 32. Exeter vase. |
| 23. Triton jug. | 33. Apsley vase. |
| 24. Hawthorn vase. | 34. Grenville vase. |
| 25. Fanny Ellsler. | 35. Beneficence. |
| 26. Naples ewer. | 36. Blind beggar, male. |
| 27. Burgundy vase. | 37. Blind beggar, female. |
| 28. Nimrod cup. | 38. Greyhounds, chained. |
| 29. Nero cup. | |

Designed by San Giovanni:—

- | | |
|----------------------------------|---|
| 39. Chamois hunt. | 47. Series of porcelain tea ware. |
| 40. Brigand on watch. | 48. Series of porcelain table ware. |
| 41. Brigand chief. | 49. Series of white granite table ware. |
| 42. Brigand with deer. | 50. Series of printed ware. |
| 43. Twig basket. | |
| 44. Improvisatori. | |
| 45. Series of porcelain jugs. | |
| 46. Series of porcelain deserts. | |

8 CLEMENTSON, JOSEPH, *Shelton, Staffordshire Potteries*—Manufacturer.

Plates, flowered mulberry. Flowered damascene, of various patterns, black, brown, green, and blue. Flowered blue, Leipsic and Chusan.

Two plates, enamelled under glaze, Parisian flower-groups and Japan beauty.

Flowered damascene, classical antiquities. Flowered mulberry corea. Flowered blue Leipsic. Flowered damascene, Tillenberg. Blue, classical antiquities. Pink Siam. Blue Tessino. Black Siam.

Soup and sauce tureens complete, flowered damascene, classical antiquities.

Tea-pots, sugar-basins, and cream-pots, flowered blue Chusan, damascene, Illenberg, brown, classical antiquities.

London-handled tea-cups and saucers, blue and brown printed, various patterns.

Cups and saucers, handled and unhandled, blue Siam; blue, classical antiquities, enamelled under glaze, Parisian flower-groups; flowered mulberry, various patterns; pink classical antiquities; flowered damascene, classical antiquities; green printed, various patterns.

Two bowls, flowered mulberry corea.

[Plates, dishes, saucers, &c., termed "flat ware," are made from moulds which form the inside of the article, the exterior being given by "profiles" of the required outline, made of fired clay, glazed. The clay is "batted" out to the necessary thickness and size, and laid upon the mould, which, is placed upon a plaster block, having an iron axle, and working on a pivot, the rotatory motion of which is effected either by machinery or by the workman's hand. The clay is pressed to the mould by the application of wet sponges, and the "profile" being pressed gives the desired contour. In this state the mould is

carried to a hot-air chamber, immediately behind the workman (of a very high temperature), fitted round with shelves, where it remains till tolerably dry, when the profile is again passed over it, and shrinking, consequent upon evaporation, having taken place, it is then easily removed.

Soup tureens, sauce tureens, jugs, teapots, &c., and termed "hollow ware," are made from *outside moulds*, formed in two or more parts, according to the facilities which the shape affords for "drawing." The clay is prepared and batted out as in the "flat pressing," and each part of the mould being separately lined with the clay, the whole are fitted together, and a strong strap passed round to secure them compactly in their places; the surface is then worked completely over from the inside (the mould giving the external surface), with a sponge, particular attention being paid to connect firmly that part of the article where the mould is divided. When sufficiently dry the mould is removed, and the "seams" well rubbed down, the surface also being smoothed with a sponge.—T. B.]

9 MAYER, THOMAS JOHN & JOSEPH, *Dale Hall Pottery, Longport, Burslem, Staffordshire*—Manufacturers.

Specimens of earthenware. Table ware in various patterns, and printed in a variety of colours. Various specimens of enamelled and gilt toilette and dessert ware. Various designs for meat pots, printed in colours, under the glaze.

Tall-candlesticks, bed, and piano-candlesticks, enamelled and gilt. Garden and rustic seats.

Various pans, enamelled, gilt, and marble printed. Enamelled and gilt plug basins. A marble painted butler's sink. Wash-tubs for public and private wash-houses, marble painted.

Enamelled and gilt finger plates and door furniture. Drawer or commode knobs, of various colours. A 3-bell lever, in jet and gold. Bell-pulls, enamelled and gilt.

Beer machine, and fire-iron handles, enamelled and gilt. Bell handles, in various colours. Enamelled and gilt cases for lamp pillars. German tactic, and solitaire boards, and lucifer match pots.

Advertising tiles, of various designs, printed in colours.

Oval and square paint palettes, made of white opaque porcelain. Indian ink slabs, of various shapes. Printed and enamelled scale plates, writing slates, and tobacco boxes.

White stone-ware punch bowls, enamelled and gilt; and jugs—with blue raised figures.

Enamelled and gilt tea urns, made of stone clay, capable of resisting the action of boiling water.

Stone appendages to offices, with perforated pipe round the top to supply a constant current of water for the purpose of washing the sides.

Artists' grinding stone, and a mortar and pestle, made of vitreous porcelain.

Funnels made of acid proof stone clay. Various articles used by the apothecary.

Vases and card baskets, in Parian ware, with a wreath of flowers. Brooches, pins, &c.

Bust of Wesley, from the original mould, belonging to the late Enoch Wood, Esq., the sculptor.

Birds' nest and bark shape jugs, in various colours; red, brown, and gold lustre porcelain, with silver wreath. An eau-de-Cologne bottle.

Dr. Arnott's ventilator.

[In enamelling, ground-laying is the first process in operating on all designs to which it is applied; it is extremely simple, requiring principally lightness and delicacy of hand. A coat of boiled oil adapted to the purpose being laid upon the ware with a pencil, and afterwards levelled, or as it is technically termed "bossed," until the surface is perfectly uniform; as the deposit of more oil in one part than another would cause a propor-

tionate increase of colour to adhere, and consequently produce a variation of tint. This being done, the colour, which is in a state of fine powder, is dusted on the oiled ground with cotton wool; a sufficient quantity readily attaches itself, and the superfluity is cleared off by the same medium. If it be requisite to preserve a panel ornament, or any object white upon the ground, an additional process is necessary, called "stencilling." The stencil (generally a mixture of rose-pink, sugar, and water) is laid on in the form desired with a pencil, so as entirely to protect the surface of the ware from the oil, and the process of "grounding," as previously described, ensues. It is then dried in an oven, to harden the oil and colour, and immersed in water, which penetrates to the stencil; and, softening the sugar is then easily washed off, carrying with it any portion of colour or oil that may be upon it, and leaving the ware perfectly clean. It is sometimes necessary, where great depth of colour is required, to repeat these colours several times. The "ground-layers" do generally, and should always, work with a bandage over the mouth, to avoid inhaling the colour-dust, much of which is highly deleterious. Bossing is the term given to the process by which the level surfaces of various colours, so extensively introduced upon decorated porcelain, are effected. The "boss" is made of soft leather.

The process of gilding is as follows:—The gold (which is prepared with quicksilver and flux), when ready for use, appears a black dust; it is used with turpentine and oils similar to the enamel colours, and, like them, worked with the ordinary camels' hair pencil. It flows very freely, and is equally adapted for producing broad massive bands and grounds, or the finest details of the most elaborate design.

To obviate the difficulty and expense of drawing the pattern on every piece of a service, when it is at all intricate, a "pounce" is used, and the outline dusted through with charcoal—a method which also secures uniformity of size and shape. Women are precluded from working at this branch of the business, though, from its simplicity and lightness, it would appear so well adapted for them. Firing restores the gold to its proper tint, which first assumes the character of "dead gold," its after brilliancy being the result of another process termed "burnishing."—T. B.]

10 MEIGH, CHARLES, & SONS, *Hanley, Staffordshire*—
Manufacturers.

Soup and sauce tureens, vegetable dishes, dinner-plates. Centre pieces, compotiers, dessert plates, &c., chased, painted, and gilt, in a variety of colours and choice designs.

Ewers and basins, soap-boxes, and brush trays, in various colours and ornamental styles.

Lotus candlesticks and jugs, Albert shape, gilt and ornamented. A porcelain ornamented candlestick, represented in the cut.

Breakfast bowl and saucer, porcelain. Porter mug, porcelain. Slab, painted fruit.

Flower-pot and stand, Flora shape; acanthus flower-pots, coloured and gilt.

Vases—pink grounds, flowers and gold, chased; Celeste ground, chased gold—The Murder of the Innocents; pair, Cleopatra and Anne Boleyn, marone grounds, chased gold.

Large vases, with portraits of The Queen, and view of the Exhibition Building; and of Prince Albert, with interior view. Large stork vase, with water birds painted on each side.

These vases, &c., are represented in the accompanying illustrations.

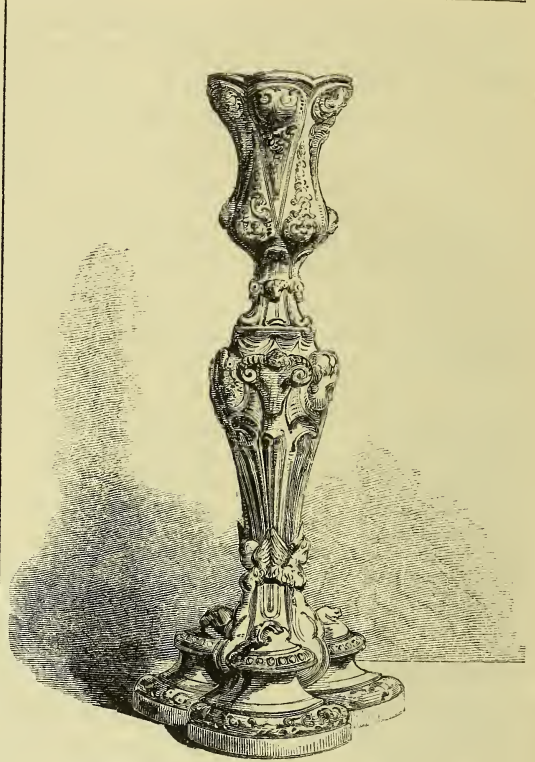

Meigh & Sons' Ornamental Candlesticks.



Meigh & Sons' Portrait Vase.

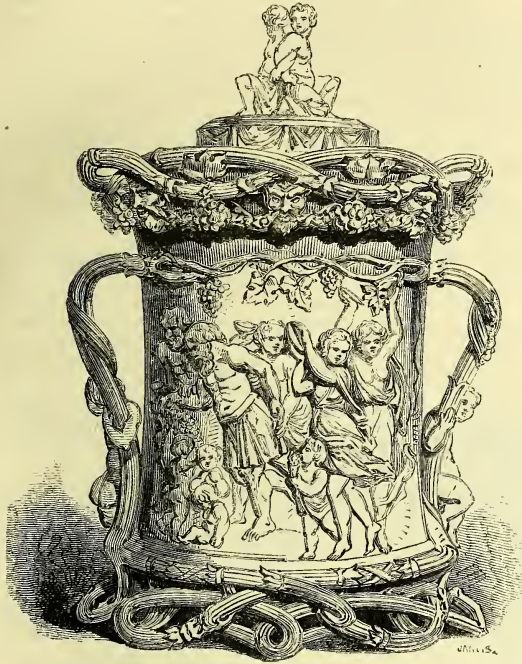

Meigh & Sons' Bacchanalian Vase.



Meigh & Sons' Ornamental Vase.

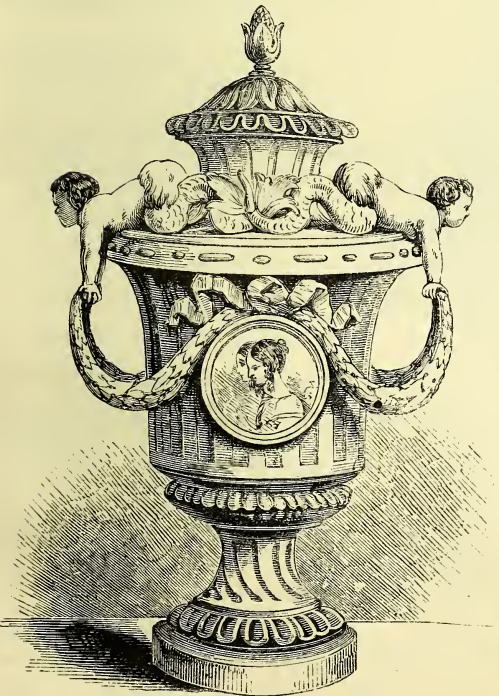

Meigh & Sons' Portrait Vase.

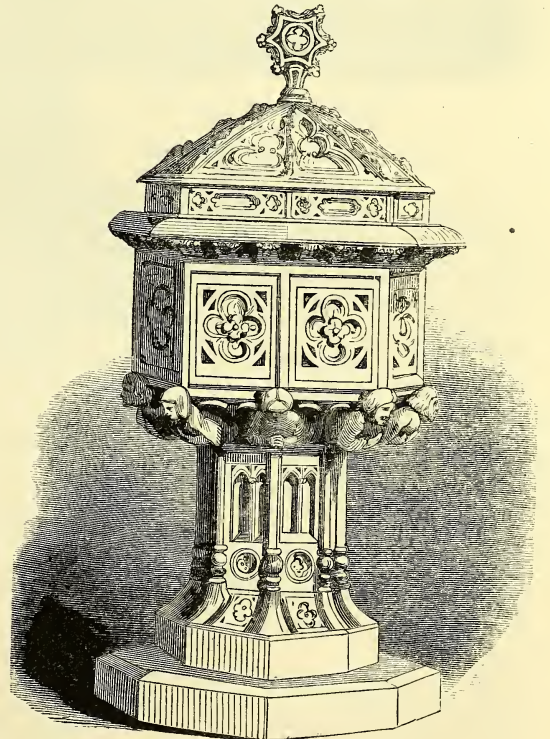

Meigh & Sons' Illuminated Gothic Font.

Tea-cups and saucers, various patterns. Cake stands. Gothic font, illuminated and gilt. This font is represented in the cut in the next column.

Large vase—history of Bacchus (Parian). Vases Maltese (Parian).

Statuettes (Parian), of various kinds; Templar and Companion; Falconer and Companion; Bather and Companion; Cupid and Venus; Dancer and Companion; Flora; Prometheus.

Clock, subject, "Night and Morning," with a figure of Silence on the top. This clock is represented in the cut in next column; and another in chased gold (Parian).

Wine coolers, Bacchanalian (Parian and terra cotta). Various figures, all Parian.

Heads of Dr. Adam Clarke, Sir Robert Peel, Shakspeare, and Napoleon.

Cornucopias, Cellini candlesticks.

Butter-tub and stand, pink ground; jugs and miscellaneous articles; mug. Society of Arts' medal. Cups and saucers.

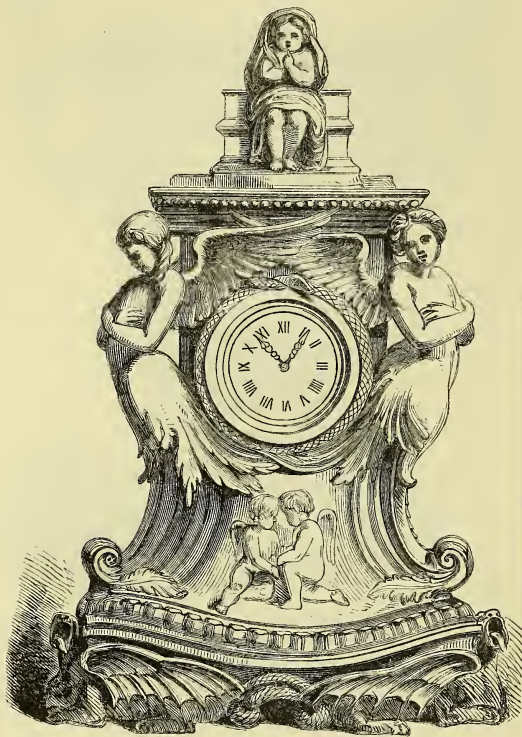

Meigh and Sons' Ornamental Clock.

11 BOOTE, T. & R., *Burslem, Staffordshire*—
Manufacturer.

Portland vase, fawn ground, white figures, about three feet high; ornamented by patent process.

Set of three Parian vases, ornamented with raised vine, drab ground, the largest three feet high. Another set, with groups of flowers, raised.

Parian allegorical group of figures. Rustic group.

Statuettes, in Parian, about 20 inches high, Shakspeare, Milton, Venus, &c. Parian vase, pierced.

Parian bust of Sir Robert Peel, taken from the picture by Sir Thomas Lawrence.

Sets of Portland and Ely jugs, drab ground, and white figures.

Pair of Doric mosaic vases, black ground, with fancy leaf, &c., in mazarine blue, traced in gold.

Set of mosaic jugs, black ground, with Grecian figures, mazarine blue, traced in gold.

Set of azure Grecian, and fawn jugs, &c., inlaid with white, traced in gold.

Sets of jugs:—Fawn ground, inlaid with white, fancy, &c., traced in gold; sage ground, Grecian figures, &c., traced in gold.

The six preceding articles ornamented by patent process.

Set of jugs, azure and sage grounds, border inlaid in white, traced in gold.

Ewers and basins:—Fawn ground, inlaid with Grecian figures, &c., cut up; white ground, similarly ornamented; azure ground, inlaid with white, cut up; azure, inlaid with blue bell, &c., in white, cut up; fawn, similarly ornamented; white, inlaid with black, and blue bell traced (the four preceding articles ornamented with gold by patent process); white, with gold bands; ground laid with blue, finished with gold, also with pink, finished with gold.

Pair of Coptic vases, black ground, with fancy leaves, &c., mazarine blue, traced in gold by patent process.

Set of jugs, sage ground, inlaid with white. Dinner plates, ground laid, traced in gold. Dessert plates, ground laid, finished off in gold. Small Parian vase, flowered.

12 DIMMOCK, THOMAS, *Shelton Potteries, Staffordshire*—
Manufacturer.

Table-plates, tureens, dishes and dish-covers, of various patterns and colours.

Garden-seats, japanned and gilt.

Wine cooler, of terra-cotta ware; in the form of a vase.

13 BOWERS, GEORGE FRED., *Brownhills, Tunstall, Staffordshire*—Manufacturer.

Specimens of ornamental earthenware cornices for rooms, and wash-board, representing carved oak and other woods. Centre-pieces for rooms in same style.

Ornamental bricks, to represent carving in wood or stone, and other decorative work.

These new articles are made under Baddeley's patent, the composition used being a peculiar description of earthenware, and the process of "pressing" the clay into the mould is effected by mechanical power.

Toy-ware; saucers, mazarine and gold; cans and saucers, and cups and saucers; green and gold; also in marone buff, green buff, fawn and fawn Greece, and gold; with saucers in mazarine red, mazarine, marone buff, and gold.

Paragon teapot, box, and cream, in white and gold.

Jenny Lind milk jug, teapot stand, slop bowl, sugar bowl, butter and stand, dishes, muffins, toast rack, bread and butter plate, bowl and saucer, and egg cup.

Card counter, pink and gold, black printed numbers.

Jugs: utility edge-line and ornamented spouts; utility and Greek bouquet sprigs, plain; utility double stripe and wreath; and Greek, white and gold.

Mugs: green and gold, with landscape; mazarine and gold, with landscape; roses and gold; double landscape; green ground; landscape and gold; and marone, gold, and flowers.

Paragon teapot, gold and flowers; bread and butter plate, drab flowers and gold, Jenny Lind; bowls and saucers, initial J. L.; French drab band and gold; French green, stripes gilt; and French marone, flowers and gold.

Teacups and saucers, Victoria embossed and Jenny Lind, white and gold. Punch bowl, gold band.

Candlesticks in pairs, gilt and flowers, marone and gold, and white and gold.

Flower bottle, flowers and gold. Set of spills, marone and celestial blue, flowers and gold.

Large double and caudled mug, gilt, lettered, and bowered.

Slabs: painted landscape, gilt frames; painted flowers, gilt frames; and the "Cottage door."

Dessert plates, gold band and flowers; salmon and landscape; gilt and flowers; fawn and landscape; white and gold; bouquet, gilt; green and fawn, odd patterns; green leaves and flowers; marone and birds; drab and flowers; stone and gold; and marone and gold.

Exhibition bread and butter plate, muffin, and bowl and saucer, black; bowl and saucer, spills and mug, red; mugs, green, pink, black, "Present from London," and gilt marone. Teapot stand, "Scinde," muffins and dish.

14 KEYS & MOUNTFORD, *The Potteries, Newcastle-under-Lyme, Staffordshire*—Designers, Inventors, and Manufacturers.

Specimens of porcelain statuary:—Statuettes of Flora; Prometheus tormented by the vulture; Venus unrobing at the bath; and two Circassian slaves.

Group of three boys, with perforated baskets for dessert, centre-piece.

Pair of figures, male and female, with glass linings to perforated vases.

Statuette of Venus extracting a thorn. Group of two dogs, setter and pointer, with game. Group of three greyhound dogs. Bacchanalian ewer from the antique. Claret vase ewer.

15 PINDER, BOURNE, & HOPE, *Burslem, Staffordshire*
Potteries—Manufacturers.

Mazarine blue ground and gilt soup tureen and stand.
Cover-dish, maroon ground and gilt Dish, 14-inch,
maroon ground and gilt. Cover-dish, mulberry printed
blue enamelled, and gilt.

Slop jar, ornamented and gilt. Mazarine blue
enamelled, and gilt.

Ewer and basin, maroon ground, and gilt. Ewer and
basin, ornamented and gilt.

Dish, 14-inch, unique colour, printed, and gilt. Plates,
mazarine blue and maroon, gilt; and various grounds,
enamelled and gilt. Plates of various colours and
patterns.

16 ANDERSON & BETTANY, *Longton, Staffordshire*
Potteries—Manufacturers.

Series of china cups and saucers, and dessert plates.

17 HILDITCH & HOPWOOD, *Longton, Staffordshire*
Potteries—Designers and Inventors.

Teapot, sugar-box, cream-jug, bread and butter plate,
and cup and saucer; Portland shape, raised patterns, gilt
and burnished.

Specimens of teacups and saucers, of various shapes
and colours, with flower, scroll, landscape, and medallion
patterns, in chased and burnished gold.

Centre-piece on pillar, with embossed vine border;
grapes suspended from the handles. This centre-piece
is represented in the following engraving.



Hilditch & Hopwood's Ornamental Centre-piece.

Mat blue ground and landscapes, raised and burnished
gold ornaments; a shell, an oval, and a square comport,
in the same style as the centre-piece.

[The operation of "burnishing" is done by females.
The tools used for the purpose, called "burnishers," are
bloodstones, firm hematite iron, and agates fitted into
handles. The gold is first scoured with fine wetted sand,
which tests the extent of the firing: if not sufficient, the
gold will not adhere; and if in excess, the brilliancy will
have been destroyed. In the first case, the ware has
to be passed through the kilns again without further
labour; but, in the latter, it has to be thoroughly re-
gilt. After "sanding," the burnishers are applied very
briskly, and immediately produce a polish, which is
increased in brilliancy by repeated action. A cloth
dipped in the solution of whiting is occasionally used
to clear the surface.—T. B.]

18 DEAKIN, EDWIN, *Longton, Staffordshire—*
Manufacturer.

Silver lustre articles:—Mouth ewer and basin; coffe
and teapots; sugar-box and cream-jugs; tea and breakfast

cups and saucers; toast-rack and egg-frame, with cups;
communion cup with handles, plate, jug and cover;
saucers, with cover, stand, and ladle complete;
vegetable dish and cover; candlestick and extinguishers;
broth bowl, with stand and cover; mugs; jugs; mustard
pots; peppers; salts, &c.

19 SERJEANT & PEPPER, *Hanley, Staffordshire—*
Producers.

Specimens of engraved patterns for printing on earth-
enware.

20 TILL, THOMAS & SON, *Lytch Pottery, Burslem,*
Staffordshire—Manufacturers.

Pekin shape articles, ewer and basin, soap-box, brush-
tray, &c.

Virginia shape jug, unique, gilt, and green pebble.

Berlin shape, breakfast cup and saucer set and bowl.

Albany shape dishes, baker and plates; pearl white
granite.

Virginia shape set, teapot, sugar, cream, cup and
saucer; in pearl white granite.

Dessert plate, gilt. Set of jugs, Catauia shape, tur-
quoise gilt tracings; another set, Franklin shape, gilt lines.

Virginia set, cup and saucer; Celeste, Lahore.
Set of jugs, pearl white granite, Virginia shape; bowls of the same. Coffee-pot of the same; Boston shape.
Sets, Berlin shape, cup and saucer, green, and gilt blue.
Albany shape soup tureen, complete, and sauce tureen, complete, white granite, gold bands; also, covered dish, &c., of the same.
Virginia shape, set tea-cup and saucer and tea-pot, white granite, gold bands.

21 CORK & EDGE, *Queen Street, Burslem, Staffordshire*—Manufacturers.

Tea services in black, lustre, drab, and lilac earthenware.

22 PRATT, F. & R., & Co., *Fenton Potteries, Staffordshire*—Manufacturers.

Terra-cotta model for a timepiece, "Paris and Helen."
Two Etruscan vases, with figures from "Flaxman's Iliad."

Porous water-coolers, plain and in enamelled colours.
Earthenware, printed in various colours, under glaze, after pictures in the Vernon Gallery, &c.

Dessert ware, with the following subjects:—

"The Last In," W. Mulready, R.A.

"Highland Music," Sir E. Landseer, R.A.

"The Blind Fiddler," Sir D. Wilkie, R.A.

"The Truant," T. Webster, R.A.

"The Hop Queen," W. T. Witherington, R.A.

"Cottage Children," T. Gainsborough, R.A.

Bread platter, and cheese dish, picture and frame, with Scripture subject, by H. Warren.

Two pictures printed in colours, under glaze, in earthenware frames. A variety of box covers, and pair of ornamental vases, in the same style.

These subjects are executed under the glaze by the ordinary process of "bisque" printing, each colour is produced from a separate engraving, and the "transfer" requires to be carefully registered.

[The process of bisque firing is as follows:—The ware being finished from the hand of the potter, is brought by him upon boards to the "green-house," so called from its being the receptacle for ware in the "green" or unfired state. It is here gradually dried for the ovens: when ready, it is carried to the "sagger-house," in immediate connexion with the oven in which it is to be fired, and here it is placed in the "saggers;" these are boxes made of a peculiar kind of clay (a native marl), previously fired, and fusible at the heat required for the ware, and of form suited to the articles they are to contain. A little dry pounded flint is scattered between them, of china and sand of earthenware, to prevent adhesion. The purpose of the sagger is to protect the ware from the flames and smoke, and also for its security from breakage, as in the clay state it is exceedingly brittle, and when dry, or what is called "white," requires great care in the handling. A plate sagger will hold twenty plates, placed one on the other, of earthenware; but china plates are fired separately in "setters" made of their respective forms. The "setters" for china plates and dishes answer the same purpose as the "saggers," and are made of the same clay. They take in one dish or plate each, and are "reared" in the oven in "bungs" one on the other.

The hovels in which the ovens are built form a very peculiar and striking feature of the pottery towns, and forcibly arrest the attention and excite the surprise of the stranger, resembling as they closely do a succession of gigantic bee-hives. They are constructed of bricks, about 40 feet diameter, and 35 feet high, with an aperture at the top for the escape of the smoke. The "ovens" are of a similar form, about 22 feet diameter, and from 18 to 21 feet high, heated by fire-places, or "mouths," about nine in number, built externally

around them. Flues in connexion with these converge under the bottom of the oven to a central opening, drawing the flames to this point, where they enter the oven: other flues, termed "bags," pass up the internal sides to the height of about four feet, thus conveying the flames to the upper part.

When "setting in" the oven, the firemen enter by an opening in the side, carrying the saggers with the ware placed as described: these are piled one upon another from bottom to top of the oven, care being taken to arrange them so that they may receive the heat (which varies in different parts) most suited to the articles they contain. This being continued till the oven is filled, the aperture is then bricked up: the firing of earthenware bisque continues sixty hours, and of china forty-eight.

The quantity of coals necessary for a "bisque" oven is from 16 to 20 tons; for a "glost" oven from 4½ to 6 tons.

The ware is allowed to cool for two days, when it is drawn in the state technically termed "biscuit," or bisque, and is then ready for "glazing," except when required for printing, or a common style of painting, both of which processes are done on the "bisque" prior to being "glazed."—T. B.]

Dessert ware, Etruscan shapes, in white and gold.

A variety of printed and enamelled dinner ware.

A mazarine blue jar, ornamented in gold.

23 DANIELL, A. B. & R. P., 18 *Wigmore Street, and 129 New Bond Street*—Designers.

Dessert services, executed at the Coalbrook Dale china manufactory.

[In these services is shown an attempt at the revival of the beautiful pink or rose colour found on the old *pâte tendre* of Sèvres, known as the Rose Dubarry. Madame Dubarry having some vases executed at the Sèvres works, the rose colour was adopted, as being the lady's favourite, in compliment to her. Colours of this character are usually produced by combinations of gold with salts of ammonia, to which sometimes tin and the oxide of manganese are added.—R. H.]

24 EARNSHAW & GRAVES, *Masborough Pottery, Rotham, Yorkshire*—Manufacturers.

Painted *biura*, exhibiting specimens of Yates' patent porcelain letters.

25 GLOVER & COLCLOUGH, *Longton, Staffordshire*—Manufacturers.

Gold and silver lustre earthenware, useful jugs, &c.

26 BELL & Co., *Glasgow*—Manufacturers.

Dinner services in stoneware:—Blue printed, landscape pattern, "Italian lakes." Flowered ware, mulberry centre with azure border, "Warwick vase," registered pattern. Pure white, gilt.

Toilet services in stoneware:—White basin and ewer, gilt, antique shape; "Diana," with registered ewer. Basin and ewer, printed and coloured. Large basin, marble pattern. Foot-bath and jug, marble pattern. Large basin, flowered mulberry, "convolvulus" pattern.

Tea services and jugs in stoneware and porcelain. Common stoneware, in dipt, sponged, and painted. Fancy articles in stoneware, porcelain, and Parian. Scent jar in stoneware, antique shape, with Turkish centre, printed in five colours. Wine-coolers, antique shape, with stands.

Articles in Parian:—Small vases, with figures in bas-relief, the body and handles modelled after a vase found in Pompeii. Antique vase with upright handles. Jugs modelled after the antique, with bas-reliefs from the Elgin marbles, representing the Battle of the Amazons. (Registered shape.) Jugs, same shape but plain, with

same subject enamelled. Bas-reliefs from the Elgin marbles, &c.

Specimens in terra cotta:—Large vase (Piranesi) with flowers and scrolls in bas-relief. Large vase, similar, but plain. Large fluted columns, serving as pedestals for these, with capitals and bases complete. Shorter columns without capitals.

[A large proportion of circular articles, not requiring ornament or relief beyond plain curved surfaces, are "thrown and turned." Few are unacquainted with the wonder-working powers of the potter's wheel. A ball of clay is placed on the centre of the revolving block, and by the simplest manipulation is made to spring at once into form and character, assuming at the operator's will any contour of which a circular vessel is capable, the plastic clay being formed or transformed with an ease and rapidity almost incredible. Every piece, when made, is cut off the block by a wire being passed under it.

When the "thrown ware" is sufficiently dry, it is transferred to the hands of the "turner," whose province it is to form the curves more truly and sharply, and to impart a uniform smoothness and polish to the surface. This process resembles that of ordinary wood turning, but from the nature of the material is executed with much greater facility. The vessel is fitted upon a block, or "chum," attached to the lathe, and the turning is performed by thin iron tools, few in number, and simple in form.

Articles of this class which require "handles" are passed from the lathe to the "handler." These useful adjuncts are made by pressure in moulds of plaster of Paris, and after being sufficiently dried are fixed on the vessel with "slip." The adhesion is so immediate that in most cases the article may be lifted by the handle before it has left the hands of the operator. When the handle is fitted, the superfluous slip which exudes from the junction after the parts have been pressed together, is removed with a sponge, and the surfaces worked together, and smoothed round with a small tool, the article is then finished, unless a "spout" or "lip" is required, as in the case of teapots, jugs, &c. These are made and attached in the same manner as "handles."—T. B.]

27 WHALLEY, T., *Stockton-on-Tees*—Manufacturer.

New compositions for glazing earthenware.

[The materials comprised in the various glazes commonly used for china and earthenware are—Cornish stone, flint, white lead, glass, whiting, &c. These, having been ground together in proper proportions to the consistence of milk, form the glaze. The process is effected in large buildings termed "dipping-houses" (china and earthenware being kept separate), fitted up with tubs for the glaze, and stages for the reception of the ware when dipped, upon which it is dried and heated generally by means of a large iron stove or "cockle," from which iron pipes, extending in various directions, convey the heat throughout the whole extent of the "houses." Each dipper is provided with a tub of glaze, in which he immerses the bisque ware. We may note the results of practice and experience in imparting a facility and dexterity of handling, so necessary to perfection in this process. The ware is held so that as small a portion as possible shall be covered by the fingers; it is then plunged in the glaze, which, by a dexterous jerk, is made not only to cover the entire piece, but, at the same time, so disperses it, that an equal and level portion is disposed over the whole surface which, being porous,

imbibes and retains it. The ware is handed to the dipper by a boy, and another removes it when dipped to the drying or "hot-house." The glaze is opaque till fired, so that the design of pattern executed on the bisque is completely hid, after dipping, till they have been submitted to the glost fire. An able workman will dip about 700 dozen plates in a day.—T. B.]

28 FELL, T., & Co., *St. Peter's Pottery, Newcastle-upon-Tyne*—Manufacturers.
Specimens of common earthenware.

29 SOUTHORN, WILLIAM, & Co., *Brosceley, near Iron Bridge, Shropshire*—Manufacturer.

Tobacco-pipes, of prepared clay, which gives them a more porous quality; with improved glaze, and green lip.

29A MICHELL, J., *Culenich, Truro*—Manufacturer.
Cornish crucibles.

30 JULEFF, J. & J., *Redruth, Cornwall*—Manufacturers.

Specimens of Cornish crucibles. Copper, lead, and silver assaying crucibles. Tin assaying crucible (black lead). Jewellers' crucibles, three-cornered and round, and black-lead crucibles.

Refiners' pots of different sizes. Skittle pots. Muffles of different sizes and shapes.

31 KAY, THOMAS, *Holbeck, near Leeds*—Inventor and Manufacturer.

Pots for horticultural purposes, with feeders. Self-feeding pots. Suspending pots for orchids. Bordering for garden walks.

32 MILLS, JOHN, *Leeds*—Manufacturer.

Specimens of Rockingham coffee-pots and tea-pots. Shell and blue shell tea-pots. Shell jugs, and smeared-black tea-pots.

33 SIMPSON, J., 28 *Theobald's Road*—Manufacturer.

Table, tea, and dessert services in earthenware. Plug basins and toilet ware. Parian statuettes.

34 WOOD, GEORGE, *Brentford*—Designer, Inventor, and Manufacturer.

Very large orange-tree garden-pots, ornamented.

35 BOURNE, JOSEPH, *Derby Pottery, near Derby*—Patentee and Manufacturer.

Specimens of articles manufactured from fine stone-ware clay, so vitrified as to be equal to glass for purposes in which the latter is employed.

Garden-labels, faced with white enamel, and lettered in black, which, from their impervious nature, are well adapted for arboretums, pleasure-grounds, &c.

Specimens of articles made from the same stoneware clay, in the "biscuit," or unglazed state, as garden-vases, flower-pots, scent-jars, &c

36 SHARPE, BROTHERS, & Co., *Swadlincote, near Burton-on-Trent*—Manufacturers.

Specimens of fire-proof baking-dishes, and other article of Derbyshire ironstone caneware, of Rockingham ware, both of native clay; and of printed earthenware, of the clay in a refined state.

The characteristics of ironstone caneware are, its capability of enduring the action of fire, its strength, and its general usefulness.

37 EDWARDS, J., & Sons, *Dale Hall, Staffordshire*—Manufacturers.

Large Parian vase, and large earthenware tray.

38 FINCH, JOHN, 6 *Pickard Street, City Road*—Patentee with F. T. Rufford of Stourbridge.

Models and sections of full-sized baths and wash-tubs. Manufactured from the designs of P. P. Baly, Esq.

Porcelain wash and steam tubs, full-sized. Glazed bricks and slabs.

Porcelain tile bath and appendages, with bath-room fitted up complete, including Busby's registered valve, showing the bath in operation.

Bath-room furniture, including porcelain angular shelves, hat-rails and pegs, looking-glass frame, soap-dish, plugs for bath, labels numbered, and door handles.

Wash-room furniture—porcelain soap shelves, perforated shelves and tiles, closet pans, and glazed pipes.

39 **LOWE, THOMAS, 40 Ely Place, Holborn—**
Painter and Producer.

Table plates, painted with subjects in the centre of each. Miniature portrait of Her Majesty, after Ross. Infant John, after Correggio. Jew's harp, after Wilkie. English rustic, after Howard.

40 **ALLEN, JOHN MILNER, 14 Catharine Street, Strand**
—Producer.
Painted and gilt China dessert plates.

41 **SHARPUS & CULLUM, 13 Cockspur Street, Charing**
Cross—Designers and Proprietors.

British china and British earthenware, of new forms and original designs. Dessert services.

British glass, showing the improvement made in British crystal. Decanters, wine-glasses, &c.

43 **BRAMEL, JOHN WAGER, 7 Coburg Place,**
Baywater—Manufacturer.

Ice pail of Rockingham china, gilt, with enamel painting of "Bird-trap," and "Charity," with snow scenes, on the foot, and stem of green holly and berries.

Vase, with painting of "Champion," after Webster. Grape basket, with Guava cup for pine apple, and wreath of gilded union flowers in china.

Pattern cabinet cups and saucers.

Breakfast cup and saucer, of the original Rockingham glaze, painted with flowers, and the rose, shamrock, and thistle, gilt.

[The Rockingham china was so named in compliment to the celebrated Marquis of Rockingham, to whose patronage was due the introduction of the very fine porcelain known by this name. This, like most of the English porcelains, consists of a clay body, through and over which the glaze is diffused. The glazes vary very much in character, but they are usually composed of silica, potash, and lead, a mixture which, being fused, produces a very transparent glass.—R. H.]

44 **CHAMBERLAIN & Co., Worcester—Designers**
and Manufacturers.

Tea service of egg-shell china, with a medallion of Shakspeare on each cup.

Communion and *déjeûne* services, of pierced or honey-comb china.

Pierced jugs, bottles, chalice, cups, and stands.

Portfolio china slabs, with view of Malvern, and scene from "Twelfth Night." Slabs and frames with paintings.

Adelaide vases, gilt, &c., with views of Constantinople and Smyrna, and painting of various kinds.

Snake-handle vases, with views of Worcester and Malvern. Coventry vases with medallions of Shakspeare and Milton.

Large inkstand; Dresden basket; China bracelets and brooches; China mortice door-furniture.

Vegetable dishes and covers. Sauce tureens and stands. Breakfast cups and saucers. Tea-cups. Dessert and table plates. Portion of dessert service—biscuit, blue band, with views, crests, and coats-of-arms.

Gold and white Dresden baskets, with paintings.

[In 1751, Dr. Wale established a manufactory in Worcester, under the name of the "Worcester Porcelain Company," and to him appears to be due the idea of printing upon porcelain—the transferring of printed patterns to

biscuit ware, as now usually adopted. From a magazine in the Museum of Practical Geology, decorated with a portrait of Frederick the Great, the date of this process appears to be 1757.

The original Worcester Company principally confined themselves to making blue and white ware, in imitation of that of Nankin, and in producing copies of the Japanese pottery.

Cookworthy, of Plymouth, appears to have carried on the business of a potter, in Worcester, until 1783, when this manufactory passed into the possession of Mr. Thomas Flight.—R. H.]

45 **BROWN, T. & M. L., 47 St. Martin's Lane—**
Manufacturers.

Dinner and dessert plates, specimens of enamelling and gilding on stone china.

[Stone china differs from the "tender porcelain," as the English ware is termed, in being a fused body; the alkali of the clays employed being, by the heat of the furnace, made to combine with the silica and alumina. Enamel colours are such as consist of metallic oxides combined with an alkaline flux, which, when exposed to a high temperature, forms a perfect glass.

When the ware leaves the hands of the painters, gilders, &c., it is carried to a receiving-room in connexion with the "enamel-kilns." The firemen select the ware from this room, according to the degree of heat they may require, and place it in that part of the kiln most likely to secure it. The different articles are ranged upon stages constructed of "slabs" or "bats," supported on "props," all made of fired clay. The time of firing is from six to seven hours, according to the size of the kiln, and whether it contains any articles of unusual size and hazard; in which case the heat is brought forward very gradually. The "ground-laying" being executed with colours less fusible than those employed by the painters, the ware so decorated is fired in separate kilns at a higher temperature, a level glossy surface being a great desideratum; and as gold is often used in relief upon the "grounds," it would be liable to sink and lose its lustre, unless the under-colour had received a greater degree of heat than is required by the gilding. The kilns are built of large fired clay slabs, made expressly for the purpose. They are about 3 feet 6 inches wide, 4 feet 6 inches high, and 6 feet 6 inches long, with circular tops, having flues beneath and around them. The fire-places, or "mouths," are at the sides, and the flames passing through the flues encircle the kiln externally. Great care is taken to prevent the admission of smoke or flame into the body of the kilns, the fronts of which are closed with iron doors, having in them small apertures, through which the firemen occasionally draw "trials" of colour made upon small pieces of ware, and thus ascertain, to a certain extent, the progress of the heat. This is a material assistance, but being drawn from one part only, still leaves a task requiring great care and nicety of judgment to manage successfully. Gold, if not sufficiently fired, will wipe off, and if over-fired will not "burnish," and the gilding has to be repeated.—T. B.]

Plates, entrée dishes, and soup tureens, *en suite*.

Tea-cups and saucers; specimens of painting and gilding on porcelain. Various articles in glass.

46 **GRAINGER, G., & Co., Worcester—Inventors,**
Designers, and Manufacturers.

Dinner and dessert plates. Soup tureens. Vegetable dishes and covers. Ewers and basins.

Plate, unglazed, to show the nature of the body. Piece broken in glazing, showing the fracture.

Chemical capsules, of various shapes.

New ware, called "Semi, or chemical porcelain."

Small cabinet tea service and tray, ornamented with sprays of wheat, in chased gold.

Dessert plate—royal design; Mediæval font, coloured. Cups, saucers, and lamp, of Worcester china. Small jugs, in Parian body.

Cast of a female hand, 14 years of age, in Parian; cast of a female hand, 80 years of age.

47 ROSE, JOHN, & Co., *Coalbrook Dale, Ironbridge, Shropshire*—Manufacturers.

Portions of porcelain embossed dinner services, crimson and gold, and turquoise and gold, &c.

Dessert-services, Rose du Barry, raised gold and flowers. Embossed dessert services, green and gold, with plants, enamelled. Embossed services, Celeste, gold and birds.

Tea-services—roses in gold ground, Victoria green and gold, turquoise ground and gold border, and white and gold.

Tripod épergne, with pierced basket, Cupids, in Parian, representing the Seasons. Smaller épergne, supported by sea-horses, in Parian.

Flower-vases, turquoise and gold, supported by dolphins; also, solid gold chased. Lamp-pillar, pink and gold.

Small coffee sets, Rose du Barry, gold, &c.; Celeste, gold, &c.

Clock-case, gilt, with figures of Time and Cupid (Parian).

Elevated flower-vase, supported by dolphins (Parian).

Pair of wrestling figures (Parian). Group of figures: subject, "The Pleiades adorning Night" (Parian). Basket, supported by three female figures (Parian). Ornamental ewers (Parian). Group of figures: "Puck and companions" (Parian).

China plates, various colours, with birds, plants, fruit, flowers, and heraldic decorations.

Large porcelain egg-shell bowl and small pieces, various.

48 LEE, JOSEPH, *Pottery, Rotherham, Yorkshire*—Manufacturer.

Sign-board, with porcelain letters.

49 POTTS, WAINWRIGHT W., *Waterloo House, Burslem, Staffordshire*—Patentee and Designer.

Specimens of patent cylindrical steam printing on tissue paper, for ornamenting by transfer, china, porcelain, earthenware, glass, japan ware, slate, marble, canvas, tin, oil-cloth, wood, papier maché, and room decorations. The machine which printed the first specimen, when properly furnished with engraved copper rollers, 30 inches wide (besides margin), is calculated to produce as much work for transferring, as 40 men can do in the same time by hand-printing. All the other specimens are produced by a smaller machine, now in common use in the Staffordshire potteries and in Glasgow, and is calculated to do half as much work in the same time; but, being on an improved principle, is more convenient in working. These machines require only a man and a lad to work them, and a small boiler to heat with steam. The transfer on oil-cloth is intended to show that the common block-printed oil-cloth may be superseded by better patterns and designs, particularly in wainscots, table-covers, screens, table-mats, &c. The style of the engraving in room decorations is intended to show that historical subjects or designs of any description may be engraved and printed, and then transferred to prepared canvas, leather, oil-cloth, plaster, wood, slate, stone, marble, &c.

50 GREEN, JAMES, *35 Upper Thames Street*—Half-Proprietor and Agent.

Papworth's registered fountain, manufactured in china or earthenware, for large saloons and conservatories, supplied by the high-water services. It can be more easily kept clean than other material, and, being capable of a

great variety of colours, is ornamental in an apartment. It is also conducive to health, by preventing undue dryness of air from heating apparatus.

51 SHERWIN, HENRY, *Wolstanton, Newcastle-under-Lyme*—Designer and Engraver.

Specimens of the ordinary style of engraving, as applied to the decoration of earthenware manufactures. The designs are engraved on table-plates, and represent flowers, with poppy, wheat, clematis, lupin, sweet-pea, and wild flowers. The plates are printed by Messrs. Josiah Wedgwood & Sons.

52 LORIKIN, JOSIAH, *68 Basinghall Street*—Producer. Patent egg-beater.

53 BATTAM, THOMAS, *2 and 3 Johnson's Court, Fleet Street*—Producer.

A princess and a priest of Bacchus; (reverse side) Minerva and Hercules: companion to the same. Feast of Bacchus. Toilet of Aphrodite: Venus (companion).

Heroon, or tomb of a hero; four figures bringing sepulchral offerings; supposed to be Orestes and Pylades at the tomb of Agamemnon.

Hesiod and the Muses, "and gave unto my hand a rod of marvellous growth of a laurel bough;" (companion), Venus, "her honours these from the beginning."

Penelope and her maids: (companion), Apollo carried in the air by a swan, accompanied by two Muses and a faun.

Tragedy of Orestes. The judges, Orestes, Minerva, Apollo, and Furies: "Go to those sacred flames, they will conduct you to the Furies:" (companion) a fight for the body of Patroclus.

A hierophant instructing a young maiden in one of the bacchanalian fêtes, above a bust of Bacchus.

The initiated and bacchantes making the circuit of the sacred wood.

Two young men disputing for the prize before a master of the games.

Telemachus in search of his father: (companion), the rape of Outhyia.

Celebrating the trenreid: (companion) chorus in honour of Bacchus.

The marriage of Bacchus and Ariadne; (reverse side), dance of two fauns and three nymphs.

Penthesilea (queen of the Amazons) slain, supported by Achilles.

Toilet of Aphrodite (Venus.)

Cassandra seeking protection of Minerva (to whose statue she clings), from the violence of Ajax; a priestess hastening away in indignation.

The Thymbrean Apollo and Cassandra. Iris and Alcu-raon.

Preparation for a sacred rite: a faun presenting to a priestess the lustral water which he carries in a stitula.

[The class of works to which these examples belong may be ranked under the head of *Reproductive Art*. The historical, mythical, and domestic events which they illustrate form vivid and instructive records of the manners and customs of the ancients. The original bases which have formed the material in this series are amongst the earliest memorials of Hellenic civilization. The date of their production extends from the second to the fifth century of the Christian era. The diversity and elegance of their forms bear conclusive evidence of the grace and beauty with which a refined and cultivated intelligence can mould the objects which minister to the humble and familiar purposes of household wants.

Their application was chiefly to domestic requirements; and it being a custom, connected with the rite of burial, to deposit within the sepulchre such objects as the deceased had most highly valued during life, the interment of a large number of these mortuary treasures, which so graphically illustrate Greek art and life, resulted. To this we owe the preservation of so interesting and nu-

merous a series of these valuable mementos of archaic taste and skill. They are composed of red clay, the figure and ornamental composition being executed on a dark liquid pigment, worked in quick-drying oils, and submitted to a considerable degree of heat, to secure effectual adhesion. Amongst the earliest designs are placed those in which the black silhouette-like figures are painted upon the red or buff ground. These vases, with the figures and ornaments in red on a black ground, mark the period when Greek art was at its zenith.

In reference to the forms of these vases, it may be instructive to remark, that a careful analysis of the best examples in the British Museum proves that every curve is the segment of a circle; and it has been mathematically demonstrated, that even in instances where the most irregular diversity of outline has been presented, that every curve has been circular and none elliptical.]

54 LIPSCOMBE, JAMES, & Co., 93 *Regent Street*--
Designers.

Fountain; the basin formed of cut glass; the pedestal of Carrara marble; inside of the basin, on marble rock-work, is a Cupid, made of biscuit china, supporting a marble cup.

Filtering machine (arabesque pattern).

55 LOCKETT, G., *Bleak Hill, Colbridge, Staffordshire*--
Manufacturer.

Various specimens of ware exhibiting samples of hand, kiln, and enamel colours.

56 DUDSON, J., *Hope Street, Shelton, Staffordshire*--
Manufacturer.

Ornamental china figures.

57 EMERY, F., *Colbridge, Staffordshire*--Manufacturer.
Colours for painting on glass and china.

58 MARSH, J., *Longport, Staffordshire*--Modeller
and Designer.

Wine-cooler and bust in terra-cotta.

59 LEITCH & HAMMOND, 11 *Mortimer Terrace,*
Kentish Town--Manufacturers.

Registered respirator smoking-pipe.

60 HUGHES, T., jun., *Colbridge, Staffordshire*--
Modeller and Designer.

Bust of Rev. John Wesley, in Parian.

61 LIPSCOMBE, F., 233 *Strand*.

Two portable fountains and two scent jars.



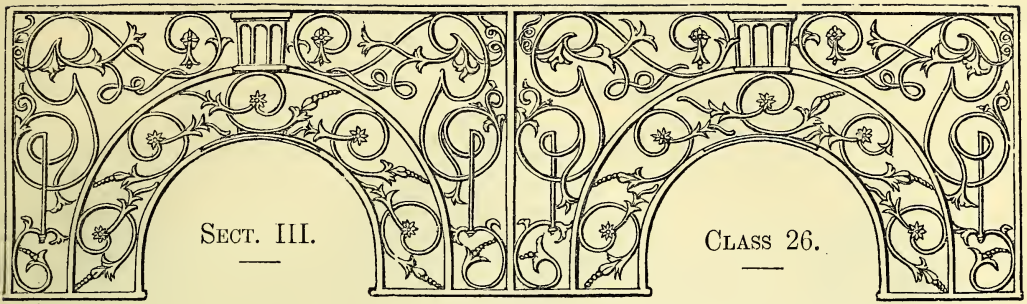

FURNITURE, UPHOLSTERY, PAPER HANGINGS, PAPIER MACHÉ AND JAPPANED GOODS.

INTRODUCTION.

THE objects contemplated by the present Class are such as pertain to decorative and domestic uses in the form of furniture exclusively of this description. All those articles for which the wants or luxuries of mankind have created a demand are represented in this Class, and a lively picture of the degree of social and domestic refinement attained in our age, and also, in fact, of the application of art to ordinary objects, is thus presented to view. The Class is a large one in regard to the number of its Exhibitors, and also to the space occupied in the Exhibition Building. The articles exhibited present evidences of a large expenditure of time and money, and many of the decorative objects appear better to become the apartments of a palace than those of persons in the ordinary walks of life.

The Class is thus subdivided:—A. Decoration generally, including Ecclesiastical Decoration; B. Furniture and Upholstery; C. Paper-hangings; D. Papier maché, Jappaned Goods, Pearl, and Tortoiseshell work.

In the Building, articles belonging to this Class will be found arranged in Areas I. J. 19 to 25, and L. to O. 21 to 24. These Areas will be readily found on the South side of the Eastern Nave, midway between the Transept and the Western Entrance. Several specimens of furniture are exhibited among the objects in the Fine Art Court. The immense mirrors in the Avenue, which may be considered, when mounted in decorated frames, as belonging to this Class, occupy a prominent position, which must render them appreciable to every visitor. Other articles, such as a Corinthian capital in papier maché, a pianoforte, and a table in the same material, are likewise placed in the Western Main Avenue. The paper-hangings are placed on the wall at the North-east corner of the Building, on the Ground Floor, and in the Gallery above. The wall decorations, imitation marbles and woods, blinds, &c., are placed against the principal walls and partitions of the Building at the South side, East and West ends, North-east corner, and in the Locomotive Avenue. In the Court, called the Mediæval Court, are also a collection of articles included in this Class.

The number of different localities producing such articles as are comprised within this Class is, as might be expected, very considerable, although a large proportion, from causes readily intelligible, is derived from the Metropolis. The production of most of the objects of furniture, presenting few mechanical difficulties, and being universally felt to be necessary, is carried on in almost every locality in this kingdom. But some of those articles which relate to decoration, as paper-hangings, are generally made in the larger manufacturing towns only. Of late, Manchester has produced a large number of paper-hangings, printed by machinery; in the Metropolis, a higher but more expensive class of paper-hanging is made principally by hand, or, in other terms, by block-printing. The manufacture of papier maché is carried on to a very large extent at Birmingham, where extensive factories have been erected, which are devoted solely to the production of a variety of objects in this useful material. The manufacture is also carried on at Wolverhampton and in the Metropolis.

The amount of ingenuity, of contrivance, and arrangement, which has been expended upon furniture, is scarcely conceivable, and it has been applied to the most common objects of domestic utility. Tables, couches, chairs, &c., have all received a share of this kind of attention; and those improvements in their adaptation to use, which have been considered worthy of more extensive introduction, are illustrated in different directions. Many specimens of furniture, formed out of timber of extreme antiquity, are exhibited. Furniture is, also, shown, the material of which is new in its application to such purposes—as timber from New Zealand, &c. The beautiful varieties of veining in mahogany, walnut, oak, and other woods, are admirably illustrated in different pieces of furniture exhibited.

Glass has lately been applied with some success in imitation of marble for the purposes of decoration. The under surface is painted with the colours and veins of marble, and the effect seen from above is not dissimilar. A variety of paper-hangings of different designs, and of decorations applied to apartments, are also exhibited. The papier maché articles are extremely beautiful, and the manner in which they are inlaid with pearl is interesting.

The appearance of the entire Class bespeaks a high degree of national prosperity; and, while displaying the skill and taste of the manufacturers, indicates not less distinctly the wealth and domestic refinement of those for whose use the greater majority of the articles exhibited are unquestionably intended.—R. E.

1 **THORN & Co.**, 98 *New Bond Street*—Designers and Manufacturers.

Gutta percha manufactures:—Decorations; girandole; various specimens and patterns of frames, brackets, mouldings, &c., gilt.

2 **WALLACE, ELIZABETH**, 4 *Russell Place, Fitzroy Square*—Inventor.

Slabs of glass, to imitate various kinds of marble, as Sienna, Egyptian green, red mona, Bardilla, verde-antique, jaspers, porphyries, serpentines, &c., applicable to walls of dining-rooms, drawing-rooms, &c.; plain and panelled on ceilings, &c., as pilasters, and columns, and inlay. Column of glass, representing malachite, surrounded by wreaths of roses, showing the application of this material to the formation of pillars, &c. Tomb of glass, representing marble, showing its durability and permanent beauty in exposed situations, such as cemeteries, &c. Picture frames and looking-glass frames, composed of a surface of glass, by which the metal, or other material beneath the glass, is protected from the action of the atmosphere. Articles of furniture, in which glass subjected to this process is the principal feature.

When properly backed up, glass obtains all the solidity of stone, and in case of accident is more readily restored by the patent process.

2A **TOWNSHEND, J. E.**, *High Street, Camberwell*—Inventor and Manufacturer.

Bedsteads for invalids, capable of being converted into an arm-chair, with wash-stand, table, and reading-desk.

3 **MELVILLE, JOHN**, 64 *John Street, Fitzroy Square*—Inventor.

A portable self-supporting pulpit, with handrails for stair, platform, &c.

4 **BURROUGHS, W., & WATTS, F.**, 19 *Soho Square*—Designers, Manufacturers, and Proprietors.

Full-sized billiard table and marking-board, of brown English oak, in the Elizabethan style.

5 **JACKSON & SONS**, 49 and 50 *Rathbone Place*—Designers and Manufacturers.

Works in carton-pierre, papier maché, and composition, for decoration and furniture. Compartment of decoration, in carton-pierre, in high relief, for a large saloon. Caryatide figure, with entablature over. String course of dolphins, bulrush, &c. Large entablature, pilaster, and console. Large ceiling flowers, of varied designs. Chandelier, adapted to gas or candles. Bracket, with group of

lights, to attach to walls. French door ornaments, in composition, in style of Louis XIV.

Console table, with boy, &c., in carton-pierre. Two groups of birds. Alto-relievo groups, wild ducks and otter hunt in the same. Writing case, papier maché covers. Book covers in papier maché. Pilaster enrichment and other specimens. Thermometer case, executed in composition. Group of boys carrying lights. Elizabethan pendentive ceiling, executed in carton-pierre. Papier maché enrichments. Centre table, dolphins, &c. Boy with lily lights, in carton-pierre and papier maché.

6 **WHITE & PARLBY**, 4 *Rathbone Place*—Designers and Manufacturers.

Model of a room, in composition ornament, as prepared for the gilder, painter, and upholsterer; including outline of design for carpet.

Ladies' work-table, in composition ornament, with slide and folding front, as prepared for the gilder and upholsterer. The same design as applicable to a writing-table, using the angle boxes for inkstands, wafers, &c., or, if required, as a work-table.

7 **BURSILL, G. H.**, 9 *York Terrace, Queen's Road, Hornsey Road, Holloway*—Inventor.

Telescopic lounge, forming a substitute for the sofa bedstead; made by J. Rubery, 1 Goldsmith's Place, Hackney Road.

8 **RIDGE, BENJAMIN, M.D.**, *Putney*—Inventor.

Invalid bed-carriage, for spinal and other complaints.

9 **TAYLOR & SONS**, 167 *Great Dover Street, Southwark*—Designers and Manufacturers.

Furniture for a steam-ship or yacht's cabin, on a new and condensed form (see the annexed engraving).

A, walnut-wood couch, forming a bed when required, stuffed with the exhibitors' patent cork fibre, to make it buoyant when placed in the water. Each part being made portable, is immediately convertible into a floating life-preserver; and the whole forms a floating surface of 50 feet, or life-raft, in the case of danger at sea.

B, walnut-wood cabinet, forming a self-acting washing-stand, and containing requisites for the dressing-room and toilette.

C, walnut-wood cabinet, as a Davenport, forming a patent portable water-closet.

Model of a balancing table, for wine, tea, soup, or any fluid requiring to be kept horizontally on board ship.

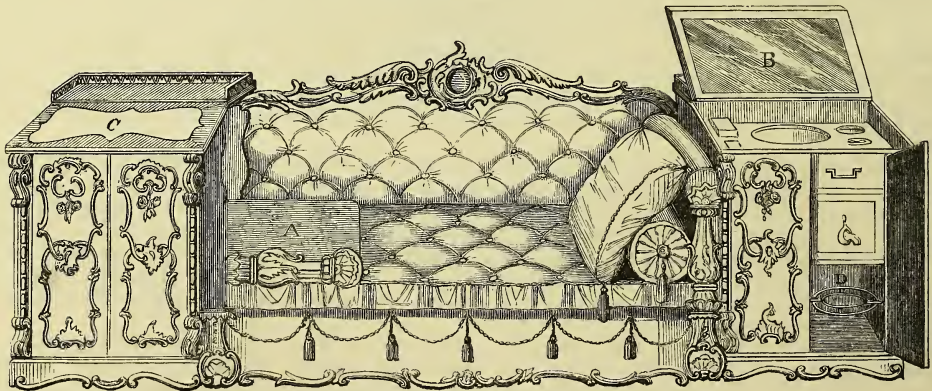

Taylor & Son's Improved Ship's Furniture.

A volva folding chair, and revolving back American seat. A cork mattress, bolster, pillow, and cushion, each of which is a life-buoy.

Slab of artificial marble of baked and polished clay; can be adapted for pavements, walls of halls, linings of baths, table-tops, trusses, capitals, or cornices, &c.

10 **JOHNSTONE & JEANES**, 67 *New Bond Street*—Manufacturers.

1. A sideboard of mahogany, in the Italian style; each pedestal consists of an infant Bacchus, with accompanying attributes, carved with foliage, grapes, hops, &c.; having a bacchante and bacchanals as medallions in the

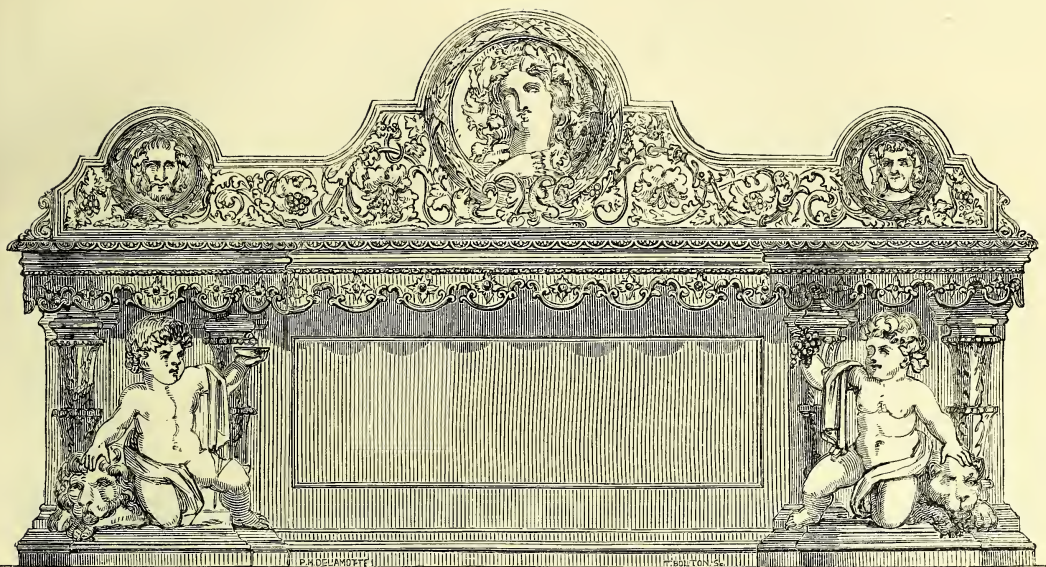

16.

CARVED SIDEBOARD. MESSRS. JOHNSTON AND JEANES.

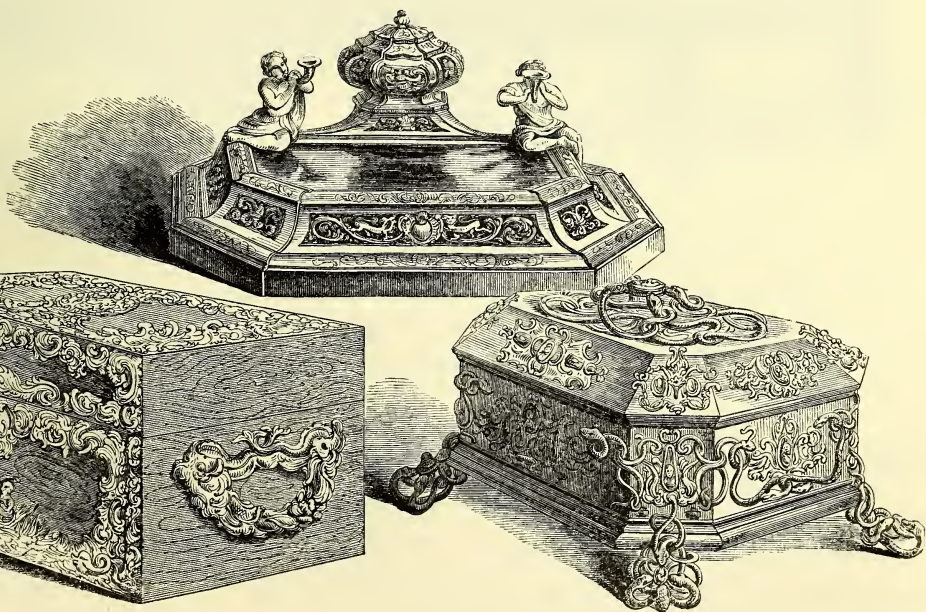

17.

DRESSING-CASE, INKSTAND, AND JEWEL CASE. MR. ASPREY.

centre, and enriched with appropriate foliage. The Plate 16 represents this sideboard.

2. A patent circular dining-table, made on a simple principle, to expand from a small to a large size, without the aid of spring or fastening, in mahogany; the stand carved in the Italian style, with grotesque masques, &c. The diagram shows the table in its closed and in its expanded state, with the form of the pieces of which it is composed.

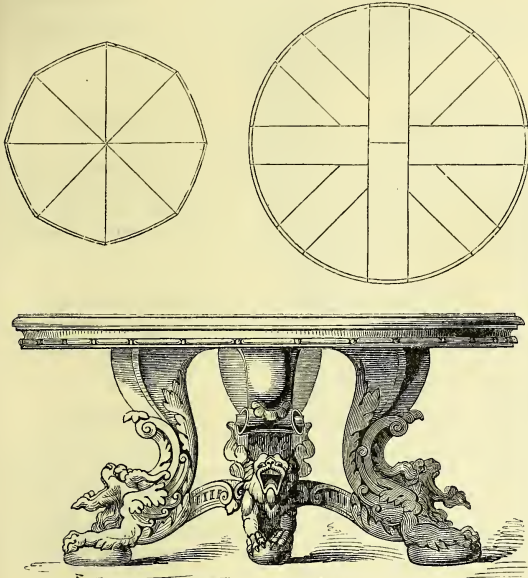

Johnstone & Jeanes' Expanding Circular Dining Table.

3. A patent expanding plateau for the dining-table, in silver plate, made with revolving arms to carry round the

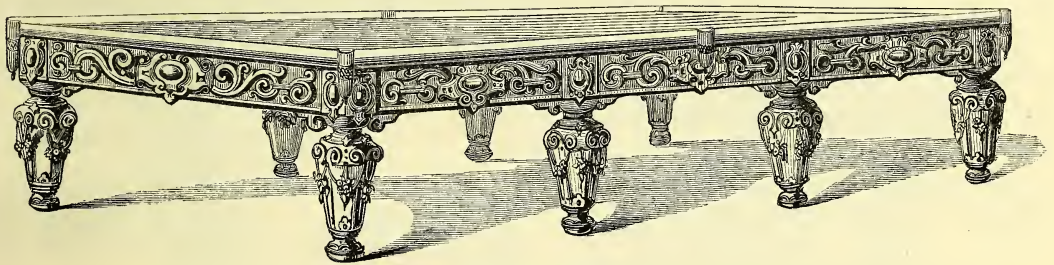

Thurston & Co.'s Slate-top Billiard Table.

18 **BLOTT, ESTHER**, Wellesbourne, near Stratford-on-Avon—Designer.

Harlequin chintz cushions stuffed with hair: design, "England's choicest flowers."
Sauces of various kinds, for game, meat, and made dishes.

19 **WYNNE & LUMSDEN**, 30 East Street, Manchester Square—Manufacturers.

Carved oak chimney-piece, for the drawing-room at Ruthin castle, designed by Henry Clutton, Esq., architect.
Carved oak altar chair, covered with crimson velvet, and embroidered with gold, for St. Bartholomew's church, Wickham; the gift of Miss Leigh. Designed by Ewan Christian, Esq., architect.

20 **CATTLE, J.**, Beverley—Designer and Manufacturer.

Elizabethan wash-stand. New pattern wash-hand stand, of English oak, ornamentally turned and carved.

dessert and wine; a massive candelabrum forming the centre ornament; the whole ornamented in foliage, birds, &c. This plateau is represented in the Plate 42, p. 746.

4. A carved library chair, in walnut tree, covered in velvet.

11 **SIEBE, A.**, 5 Denmark Street, Soho—Manufacturer.

A carved flower vase, made of the wood and metal of the Royal George.

13 **EARP, EDWARD**, 15 Chester Terrace, Chester Square—Manufacturer.

Ornamental rustic oak chair. Miniature chair and stool.

14 **RIDDLE, THOMAS**, 54 Wells Street, Oxford Street—Manufacturer.

Invalid wash-stand, of maple, for persons confined to bed, forming a small table or stand; may be used in the ordinary way by attaching the long turned legs.

15 **BROWN, J. M. & T.**, 165 Piccadilly—Inventor.

Patented suspensory chair, forming a couch or camp bed. Adapting itself to every movement of the body; fitting closely the back and loins, and giving great support and rest to invalids, or persons afflicted with spinal complaints; it is also of essential service to the military profession, from its portability and several uses.

16 **DIXCEE, THOMAS**, 14 Salisbury Place, New Road—Inventor.

Self-swinging cot, or cradle for infants (or invalids). Model of a fire-escape.

17 **THURSTON & Co.**, Catherine Street, Strand—Designers and Manufacturers.

Slate-top billiard-table, with patent cushions, made of Spanish mahogany, on eight massive legs, which, together with the frame and panels, are carved and perforated in the styles of Elizabeth and Francis I. This table is represented in the following engraving.

Marking-board and cue-rack *en suite*.

21 **THE GUTTA PERCHA COMPANY**, 18 Wharf Road, City Road—Patentee.

Table and pier glass in gutta percha ornament, in the natural colour.

22 **HUTCHISON, EDMUND**, High Wycombe, Buckinghamshire—Producer.

Antique arm chair, of oak, with carved ornaments, carved pillars, stuffed silk velvet seat and arms. The carved work executed by Edmund Hutchison, jun.

23 **LOVEGROVE, H., jun.**, Slough, near Windsor—Inventor.

Portable expanding chair, of cane and English ash. By moving the thumb-screw in the seat, it is raised to any suitable height; by moving the other screw, it is made to fold up altogether.

Portable sofa chair, of cane and cherry-tree wood.
Portable chair, of English oak.

- 24 **FLEET, J.**, *Tenterden, Kent*—Inventor and Manufacturer.
Bed-post, specimen of spiral turning with a common lathe and sliding apparatus. Invented by the exhibitor.
- 25 **GRUBB, F. C.**, *Banbury*—Manufacturer.
Carved bread platters for the dining-table. Ladies' work-table, with portable needlework frame of English walnut, the inside of sycamore.
- 26 **STARKEY, THOMAS**, *Farthinghoe, near Banbury*—Manufacturer.
Table, convertible into a bedstead, wardrobe, bed table, suite of drawers, seat, closet, and a sponge bath. Curious tables as specimens of British woods.
- 27 **EVEREST, JOHN**, *Tunbridge, Kent*—Manufacturer.
Patent ottoman, convertible into a chair, with com-mode enclosed. Invented and patented by Everest and Osborne, Tunbridge, Kent.
- 28 **ROSE, ELIZABETH**, *Oxford*—Producer.
Screen embossed on both sides, convertible into a chess table.
- 29 **SHACKLOCK, G.**, *Bolsover, near Chesterfield, Derbyshire*—Designer and Manufacturer.
Carved chair of native oak, illustrating by a series of heraldic devices the descent of the present Royal family of England from their Saxon and Norman ancestors, commencing with the arms of Edward the Confessor.
- 30 **LYON, W.**, *Marlborough, Wiltshire*—Producer.
Iron compressed bedstead.
Compressed chairs and table.
Agricultural machine, constructed to plough, sow, manure, and roll the land in succession.
Stove, to bake, roast, boil, broil, fry, heat plates, &c., all at the same time.
- 31 **GEAKE, THOMAS**, *Sherborne, Dorset*—Designer and Manufacturer.
Model of an extending dining-table, on an improved principle.
- 32 **HORNE, ROBERT**, 41 *Gracchurch Street*—Manufacturer.
Registered drawing-room decoration. Oak decoration for a dining-room or library. Samples of dark knotted oak, pollard oak, maple, and satinwood, for paper-hangings.
- 33 **FOSTER, GEORGE**, *East Retford, Nottinghamshire*—Designer and Painter.
Panel for wall decoration, painted in encaustic. Panel in imitation of inlaid wood, for doors of drawing-rooms and decorated apartments.
- 34 **HUDSON, JOHN**, *East Retford, Notts*—Proprietor.
Rustic chair, designed and made by William Marsh, of Retford, of knots of wood taken from trees grown in Sherwood forest.
- 35 **LAMBERT, S.**, *East Retford, Nottinghamshire*—Inventor and Manufacturer.
Mahogany easy chair, with new and simple mode of adjustment.
- 37 **FISHER, JAMES WHITING**, *Calvert Street, Norwich*—Manufacturer.
Loo-table, in veneer, of English growth, viz., walnut-tree curls, and intersected with laburnum tree, star, in centre, and border. It can be taken to pieces, ready for packing in case, in a few minutes.
- 37A **GUSHLOW, THOMAS**, 34 *Newman Street, Oxford Street*—Manufacturer.
Specimens on slate, in imitation of china, adapted for table-tops. Tea-trays of every description, in iron, papier maché, and other materials.
- 38 **FREEMAN, WILLIAM & CHARLES**, *London Street, Norwich*—Designers and Manufacturers.
An ornamental cabinet, secretary, and bookcase, carved in walnut wood and ebony.
The design of this cabinet is mixed, and combines a variety of figures—griffins, cherubim, &c.
It is represented in Plate 98.
- 39 **PUXLEY, WILLIAM**, *Norwich*—Designer and Manufacturer.
Ornamental flower-table, slate top, illustrated with painted views of Norwich; carved maple, and knotted oak-wood border, decorated composite pedestal and claws; with a dial affixed (detached lever), showing the time on the top of the table.
- 40 **FONNEREAU, KATE G.**, *Ipswich*—Inventor and Designer.
Octagon box, in imitation of inlaid wood, applicable to pianofortes, &c.
- 41 **HANBURY, LOUISA EMILY**, *Ipswich*—Designer.
Slab, in imitation of marble, supported by carving in wood, representing a globe, surmounted by the Prince of Wales's coronet, inscribed with the motto "Ich dien." Produced by rubbing painters' brushes on a piece of board, after ordinary use for a twelvemonth, and then making a level surface with pumice-stone; and finishing with a coat of varnish.
- 42 **RINGHAM, H.**, *Gar Street, Ipswich*—Manufacturer.
Rood screen, carved in oak for a church in Surrey. The design by Joseph Clarke, Esq., architect, 13 Stratford Place, Oxford Street, London.
Group of wheat and poppies, carved in lime-wood. A study from nature.
- 43 **WHYTE, W.**, *Banffshire*—Producer.
Table and work-table.
- 44 **BATES, THOMAS HORROD**, *St. Albans, Herts*—Designer and Manufacturer.
Rustic loo table, supported by four pillars, the top showing two crowns, the letters V. R., the borough arms of St. Albans, &c., composed of upwards of four thousand pieces of English wood—oak, maple, hazel, willow, and crab.
- 45 **ABBOTT, J.**, *Horse and Groom, Crouch Street, Colchester*—Producer.
Inlaid pentagon table. Inlaid table with carved pedestal, the sole work of the exhibitor, by trade a blacksmith.
- 46 **CHEEK, WILLIAM**, *Saffron Walden, Essex*—Designer and Maker.
Ebony cabinet inlaid with ivory, a repository for small curiosities, as coins, medals, and jewels, forming a central piece of furniture with six façades or fronts, three with open drawers, and three inclosed with doors, each division being separated by column and pilasters. The plan is an intersection of ovals, convex and concave, with drawers between each pedestal.
Ebony cabinets, inlaid with ivory, of hexagonal shape, showing front on its six sides, with rising dome for secret partition.
- 48 **GARTHWAITE, W.**, *Darlington*—Producer.
Imitations of various woods, in painting.



C. P. NICIOLLS

49 RIDDETT, GEORGE, *Ryde, Isle of Wight*—Inventor and Manufacturer.

Patent reading-table, by which an invalid in a recumbent posture can read with as much facility as when sitting; it forms also a music-stand, table, or screen.

50 EYLES, HENRY, 31 *Broad Street, Bath*—Designer and Manufacturer.

An English pollard-oak table, supported by four dolphins entwined with foliage of oak, and ornamented with various other English devices; in the centre of the top is a porcelain star, with Prince of Wales's plume, garter, &c. The china manufactured by Messrs. Chamberlain & Co., of Worcester.

English walnut-tree easy chair, with porcelain panel in the back, round which is carved the rose, shamrock, and thistle, surmounted by a lion, and ornamented with marquetric. The seat of crimson satin, embroidered with the royal arms.

English walnut-tree drawing-room chair, with porcelain panel in the back, ornamented with marquetric, white satin seat, embroidered with the rose, shamrock, and thistle.

52 HEASMAN, WALTER, 60 *Middle Street, Brighton*—Inventor.

Model of a circular roller-blind of improved construction.

53 PALMER, RICHARD, *Brighton*—Manufacturer.
Specimens of mahogany and oak-staining on deal.

54 NYE, E., *Mount Ephraim, Tonbridge Wells*—Manufacturer.

Marine table; a mosaic of 110,800 pieces, composed of the following woods in their natural colours: English—barberry, acacia, oak, laburnum, sycamore, walnut, white holly, grey holly, laurel, and oak and birch in a state of partial decay; Foreign—tulip, bar, natural purple, beef, cocus, black ebony, green ebony, Madagascar, satin, canary, fustic, orange, partridge, and rose-wood.

Chromatope table; a mosaic of 129,500 pieces, composed of the following woods in their natural colours: English—barberry, white holly, grey holly, laburnum, plum, oak, yew, chestnut, hawthorn, furze, broom, laurel, lilac, acacia, birch, walnut, and oak and birch in a state of partial decay; Foreign—tulip, king, black ebony, green ebony, palmyra, partridge, prince's, canary, Botany Bay oak, beef, fustic, orange, zebra, cam, bar, and natural purple. Design: birds (North American), grosbeak and Baltimore oriole.

Book-stand, with drawer. Designs:—Butterfly, native of Africa and India, name *Iphias lucippe*—a mosaic of 11,000 pieces of English and foreign woods in their natural colours; and butterfly, native of Amboyna, name *Vanessa juliana*—a mosaic of 12,000 pieces of English and foreign woods in their natural colours.

Work-box; the centre is a mosaic of 15,000 pieces of English and foreign woods in their natural colours, and represents a portion of the ruins of Bayham Abbey, near Tunbridge Wells, the property of the Marquis Camden.

55 CALDER, JOHN, 4 *James Street, Bath*—Designer and Manufacturer.

Circular revolving dining-table, of walnut, with portable sweep-flaps; the centre part revolves, while the outside portion, or flaps, remain stationary.

56 HORSFALL, MRS., *Hawkeworth Hall, Bradford*—Producer.

Group of flowers painted on marble in gilt frame.

57 ENGLISH, EDMUND FRANCIS, *Bath*—Designer and Manufacturer.

Pedestal cabinets, composed of ebony and various Italian marbles, relieved with gilded mouldings. The fronts of the drawers of Florentine mosaic.

Ebony bracket-sconces for lights, relieved with gilding and malachite.

Suspending cabinet, made of English oak enriched with carving and gilding.

Cabinet nest of drawers, of English oak and ebony.

Console table, the stand modelled from an original design.

59 PALMER, HENRY, 5 and 6 *James Street, Bath*—Designer and Manufacturer.

Registered loo-table in walnut wood; the stand carved in bold relief, in the Italian style, with dancing boys; strength and lightness of outline are combined. Occasional table, *en suite*. Sideboard, in English dark oak, carved in relief, in the Italian style, with emblematical representations of the four seasons, &c.

61 KING, C., *Tonbridge Street, New Road*—Producer.
Decoration window.

62 CLARKE, & Co., 29 *West Street, New Road End, Leeds*—Inventors.

Covering for the walls of apartments. It is made upon the wall, and presents the appearance of superfine cloth. Its surface is entirely seamless, whatever be the size or shape of the room.

62A HOLLAND, W., & SONS, *Stained Glass Works, St. John's, Warwick*—Manufacturers.

Imitations of inlaid marbles, in wood decorations and table tops.

63 HALL, THEODOSIA, 1 *Baring Place, Exeter*—Designer and Executor.

Cheval-screen, ornamented with a group of flowers from nature, and intended to illustrate a new style of working in Berlin wool.

64 AZULAY, BONDY, *Rotherhithe*—Inventor.

A Berlin pattern, printed in one colour, from which needlework of various colours and shades can be worked. On a sheet of paper are glued single threads of wools, the shades of each colour, in rotation. The colours are lettered, and the shades numbered; the squares in the pattern are then filled in with a number and a letter, according to the particular shade of colour required.

New pattern for dissecting puzzles; the pictures in geometrical figures.

65 TANNER, W., 3 *Harrington Place, Bath*—Producer.

Carved rigo and pollard oak cabinet, style Francis I., adapted for a drawing-room.

66 STOPHER, T., *Saxmundham*—Designer and Manufacturer.

Reading, writing, and dressing desks.

67 HERBERT, W., *Market Street, Oxford*—Designer and Manufacturer.

Occasional table, of British oak, the growth of Stanton St. John Wood, near Oxford.

Reading-table, with elevating top, of British oak, of same growth.

Cabinet, also of Stanton oak, combined with glass and or-molu. The interior adapted for papers, coins, jewels, &c. The work of two deaf and dumb youths, and the ornamental part carved by a person similarly circumstanced. The castings are by Messrs. Marsh, of Dudley, Staffordshire.

Cabinet, of Oxfordshire walnut, with similar combination of wood and glass.

Lounging-chair, of Stanton oak. The back can be raised or depressed at pleasure.

69 HOCKENDON, J., 15 *King Street, Oxford*—Inventor and Manufacturer.

University telescope reading-table, capable of being adjusted to any height.

70 SPIERS & SON, 102 & 103 *High Street, Oxford*—Manufacturers.

Specimens of decorated papier maché, consisting of tables, cabinets, fire and hand screens, albums, writing-portfolios, desks, envelope-cases, work-boxes, card-trays,

panels for internal decorations, &c.; ornamented with views of Oxford and its neighbourhood. Upwards of 100 subjects are introduced, consisting principally of the colleges, public buildings, college-walks and gardens, and general views of the city.

Specimens of University inkstands.

An ornamental fire-screen of papier maché, with a view in Oxford, the Martyrs' Monument. This screen is represented in the following engraving.

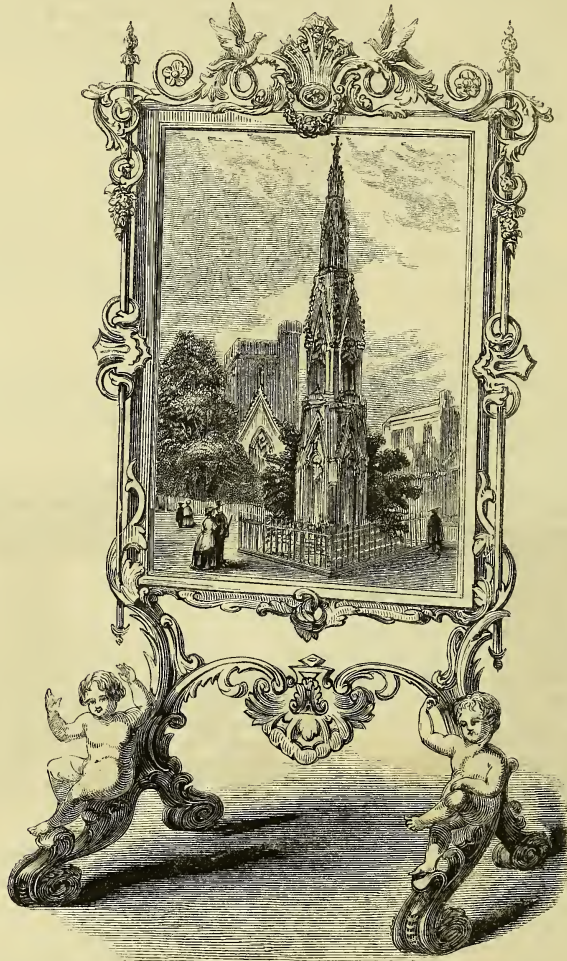

Spiers & Son's Ornamental Papier Maché Fire-Screens.

71 HEYWOOD, HIGGINBOTTOMS, SMITH, & Co., *Hyde Road Works, Manchester*, and 62 *Walling Street*—Manufacturers.

Specimens of registered paper-hangings, manufactured by machinery, in which fourteen cylinders were employed; the cylinders employed can be made to produce a still greater number of colours, and each colour is made to fall precisely into its proper place.

72 WARNER, M. R., *Stanton Harcourt, Witney*—Designer and Manufacturer.

Rustic table, inlaid with 1851 pieces of ivy wood.

73 WOODMAN, H. G., *Melksham*—Inventor.
Carpet strainer.

74 POTTER, C. H., & E., *Over Darwen, Blackburn*, and 30 *Budge Row*—Designers and Manufacturers.

Patent paper-hangings, with registered designs. By this invention, upwards of ten colours are produced by machinery and blocks.

75 JOHNSTON & Co., *Quay Street, Bristol*—Designers and Manufacturers.

Improved straw mattress for lath and iron bedsteads.

76 SPURRIER, C., *Bristol*—Designer and Manufacturer.

Cabinet chiffonnière of walnut wood, carved centre. A vase of flowers, of pearl inlaid in ebony, the ends open with plate glass.

Easy chair, with self-adjusting back and leg-rest, covered with satin damask.

New-shaped ottoman, spring stuffed in brocatelle.

77 BURTON, Miss, *Edinburgh*—Producer.

Picture-frame ornaments, made of embossed leather.

78 JONES, ARTHUR JAS., 135 *Stephen's Green, Dublin*—Designer and Manufacturer.

Series of Irish bog-yew decorative furniture, designed to illustrate the history, antiquities, animal and vegetable productions, &c., of Ireland.

No. 1, a cabriolet sofa, with chimeras at front com-

posed of head of Irish wolf and hoof of the giant deer, both animals now extinct. The back surmounted by war trophy, with badge of the order of St. Patrick. The pillows in form of shamrock, covered in Irish tabinet.

No. 2, an occasional table, the top curvilinear and moulded, presenting a fine specimen of the delicate and beautiful figure, close grain, and susceptibility of high polish of the bog-yew. The frame and pillars elaborately carved: bards' heads at four corners. The centre of the stretcher ornamented by a group representing the destruction of the wolf by the Irish wolf-dog. The massive pillars and claws enriched by scrolls, foliage, rose, shamrock, and thistle. This table is represented in the cut, with the timepiece mentioned in No. 12, placed upon it.

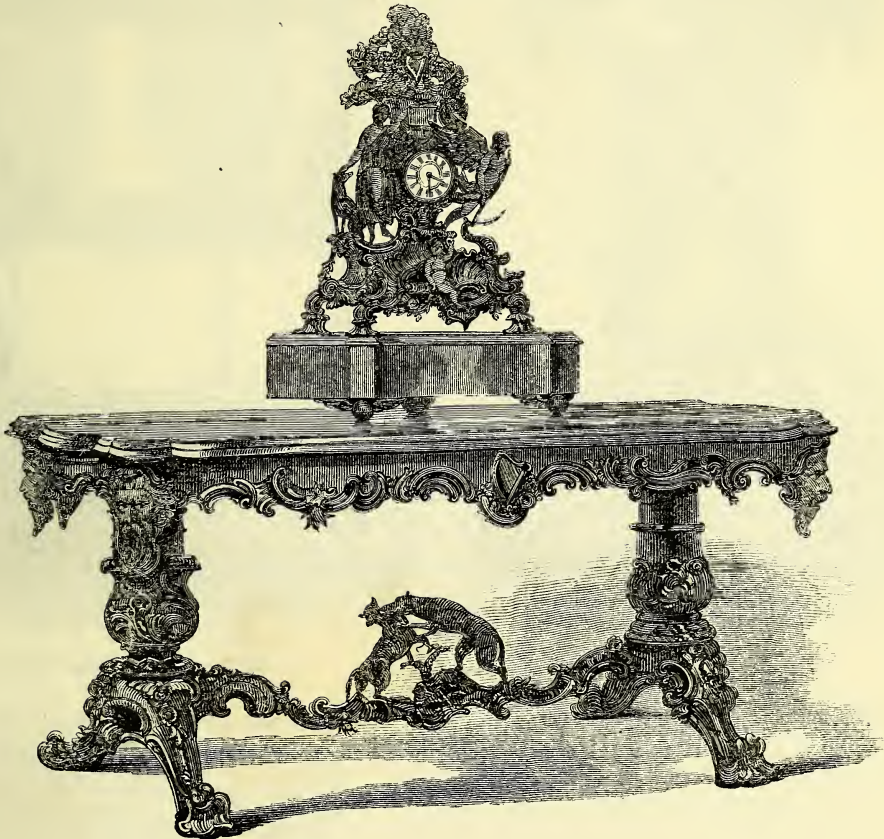

Jones's Irish Bog-yew Occasional Table and Timepiece.

No. 3, a circular table, exhibiting a similar fine specimen of the wood, supported on tripod, decorated with Irish harp and crown, fruit, flower-work, &c. The frame under top elaborately carved, and antique moulding on the edge.

No. 4, a teapoy: this article, forming a receptacle for foreign produce, has been designed to represent the ancient commerce of Ireland: accordingly, a figure of Commerce is placed on the summit, surrounded by the exports of Ireland. Emblematical bustos, copied from Flaxman's figures on the south front of the Custom-house, Dublin, representing the four divisions of the earth, embellish the four corners; and behind each, on the lid of the teapoy, are groupings characteristic of the military, scientific, and literary genius of the four great divisions of the ancient world. The intermediate spaces contain specimens of their most remarkable vegetable productions. The front panel, in bas-relief, represents Hibernia inviting Commerce (symbolized by a Tyrian merchant-galley) to the shores of Ireland: she is seated beneath the basalt cliffs of the Giant's causeway,—the

giant deer on the heights. The article being specially a lady's piece of furniture, the appropriate legendary ballad of—

“Rich and rare were the gems she wore,”

by Thomas Moore, Esq., furnish three scenes to enrich the other fronts. The support of this teapoy presents the chase of the giant deer by wolf-dogs: the animal appears bounding through the oak forest and suddenly entangled by his antlers—the dogs rushing to their prey. The cut (p. 736) represents this teapoy.

No. 5, an omnium, containing three plateaus, on massive and carved base and claws, from which rise two end standards, formed by an Irish spear entwined with shamrocks; a tray round three sides of top, enriched by open foliage-work of ivy, arbutus, yew-tree; old round castles, copied from existing ruins, connect the corners. This omnium is represented in the cut (p. 736), surmounted by No. 6, a statuette of Her Majesty.

No. 6, a statuette of Queen Victoria ornaments the top of the former article. Her Majesty sits on a chair



Jones's Irish Bog-yew Teapoy.

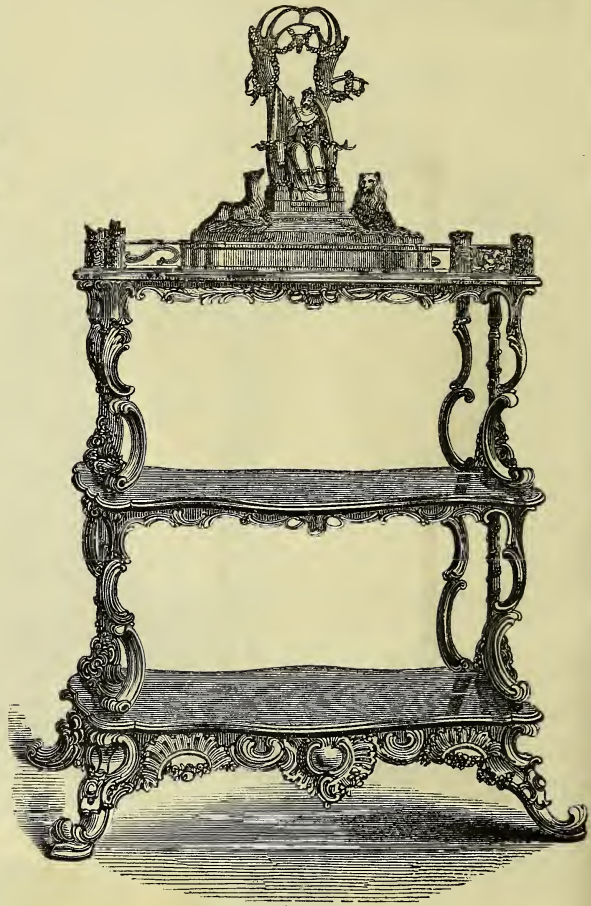

Jones's Irish Bog-yew Omnium and Statuette.

of state, holding a sceptre of peace in her right hand, and in her left a wreath composed of rose, shamrock, and thistle. The British lion supports the throne on the right, couchant upon the imperial shield; and the Irish wolf-dog on the corresponding side looking up with attachment to the Queen, his fore-paws resting on a heart-shaped, shield engraved in Irish characters, *Cushla Machree*, "Vein of my Heart." A canopy composed of the antlers of the giant deer, with tresses of shamrock, surmounts the chair.

No. 7, an omnium to match the former one.

No. 8, a statuette of Brian Boroighme, "Brian Boru," monarch of Ireland, surmounts this article. He is represented on the victorious field of Clontarf, with his battle-axe in his right hand, in an attitude of defiance, and in the act of trampling upon the broken Danish banner and ensign. The monarch appears in the appropriate costume and armour of his time; the wolf-dog reposing on the shield after the battle, with the sun-burst beaming forth, emblematic of better days, is among the accessories.

No. 9, whist table. The pillar and claws carved with rose, shamrock, and thistle, scrolls, foliage, &c.

No. 10, loo table to match.

No. 11, lady's work table, supported by crest and antlers of the Irish giant deer. A collar of shamrocks terminates the bust. A bouquet of Irish wild flowers enriches the front of the pit. The top displays the variegated and beautiful figure of the Irish bog-yew.

No. 12, a table, or bracket-stand for timepiece. From the base rises an oak tree, whose branching foliage forms the receptacle for the clock. On the right hand is a figure of Hibernia leaning with one hand on the head of the wolf-dog, and from the other depends a scroll, inscribed with the national motto, *Erin-go-bragh*, or "Ireland for ever." On the left hand is a figure of Time, with expanded wings, and whose scythe, made of Irish silver, has inscribed on the blade, in Irish gold letters, another national motto, *Faugh-a-Baughlagh*, "Clear the Way." The block on which it rests is constructed for a barrel organ to perform six old Irish airs, and rests upon winged globes, emblematic of the world itself passing away with the lapse of time.

The timepiece has its dial of Irish fine gold, and the hands of Irish silver; the hours are marked by Irish diamonds, and the minutes by Irish pearls; a beautiful specimen of Irish malachite of copper forms the centre. The clock, and the blade of the scythe of "Time," were manufactured by Messrs. West and Son, goldsmiths and jewellers, College-green, Dublin. This timepiece is represented standing upon the occasional table No. 2.

No. 13, pair of pole fire-screens, on tripods composed of three busts with helmeted heads; surrounding pillar and pole, terminating with copy of an antique bronze spear head—the original in Royal Irish Academy's Museum. The mounts consist of chivalric shields enriched with busts, scrolls, rose, shamrock, and thistle. The looking-glass panels form the field on which is sculptured in demi-relief, on the one, the ancient Irish kern, or

light-armed warrior; and on the companion the gallow-glass, or heavy-armed warrior. These fire-screens are represented in the annexed cut.



Jones's Irish Bog-yew Fire-screens.

No. 14, a fauteuil, or arm-chair. Chivalric busts of

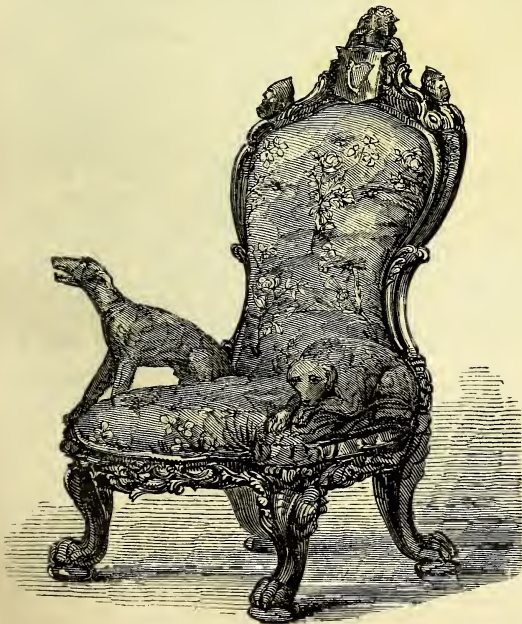

Jones's Irish Bog yew Arm-chair.

ancient Irish warriors form the outline of the back, and

the ancient arms of Ireland, as given on the authority of Sir William Betham, Bart., are in the centre. The elbows of the chair formed by wolf dogs—one at ease and recumbent, with the motto on the collar, "Gentle when stroked;" the other irritated, with the counter motto, "Fierce when provoked." This chair is represented in the preceding cut.

No. 15, a specimen drawing-room chair. To match the above; one of a set of eight, the remaining seven being in progress.

No. 16, a semicircular, or horseshoe wine table, supported by the harp of Brian Boru and bacchanalian standards. The screen at the back ornamented by satyrs, grapes, and foliage, vases of fruit, and the badges of the three principal orders of knighthood, the Prince of Wales' Plume in the centre, and the St. George conspicuous above. In the centre of the screen is an historic sculpture in high relief, representing the punishment of inhospitality, or the abduction of the young St. Lawrence, heir of Howth, by Granuwaile, the Irish princess, on her landing at Howth, when returning to Ireland from the Court of Queen Elizabeth. Granuwaile having landed proceeded to the castle for refreshment, when the gates were closed, and the gate-keeper informed her the family were at dinner, and no person could be admitted. Retiring in disgust and irritation, and proceeding to the shore, she met with a child in care of attendants, who, on inquiry, proved to be the young heir of Howth: she immediately ordered her attendants to seize the boy: a sturdy sailor conveys him to the boat at the stern command of Granuwaile; the female attendants are in grief and dismay; the young heir is conveyed away to the west of Ireland, and not restored for fifteen years; and then only on condition that the gates of Howth Castle shall never be closed at the dinner hour, a condition which is fulfilled to this day. The scene of this remarkable transaction is laid at the old landing-place of Howth, the spot where it actually occurred, and the point of view selected, is where the late King, George IV., first set foot on Irish ground. The hill of Howth forms the background; Lord Howth's castle being to the right of the spectator. The leading objects on the acclivity of the hill, and the ruins of the old abbey church, are shown.

Stretching out to the left, Ireland's Eye, with its conspicuous and picturesque craggy cliffs, is depicted from nature. Around this picture, forming a sort of frame, are objects in keeping with marine scenery, shell-work, coral, fishing apparatus, &c.

From the centre of the screen, projects an ornate rotatory coaster, composed of rich clusters of grapes and foliage, and traverses the inner semicircle of the table. Arising from the coasters are two aerial figures, the Irish fairy man and woman, supporting an ancient Irish meather, and pointing to the national motto inscribed thereon, *Cead mille failte*, "A hundred thousand welcomes."

The ancient Irish entertained a strong superstitious belief and reverence of "Fairies," or "Good People," attributing virtues and vices, with their corresponding rewards and punishments, to their influence; so that every propensity, whether bad or good, resulted from their enchantment. They are represented on the coaster as exercising their bewitching power to tempt the lovers of the "pure blood of the grape" to exceed due bounds. In this period of their progress they appear in celestial forms and with captivating smiles; but having accomplished their purpose, they are capable of assuming the most malignant and hideous aspects, and inflicting deadly punishments.

No. 17, a sarcophagus wine-cooler, or garde-vine, sculptured on the four sides, and enriched with bacchanalian busts at the four corners, and also with fruit, foliage, and appropriate emblems. A figure of Hibernia ornaments the top, with the accessories of wolf-dog, harp, &c. The top is constructed to elevate by an improved sliding stem and spring catch. This wine-cooler is represented in the cut on next page.

No. 18, music temple. The ancient and modern Irish

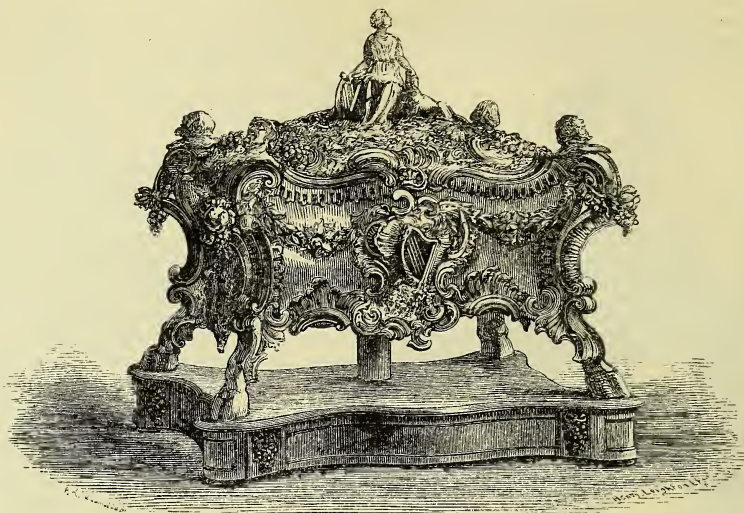

Jones's Irish Bog-yew Garde-vin, or Wine-cooler.

being passionately fond of music, a decorative piece of furniture embodying this characteristic required importance and prominence; and, therefore, the ancient palace of Tara is selected as the proper theatre in which to display this subject, its halls having been celebrated by the ancient Irish poets as the scenes of music and festivity. A statuette of Ollamb Fouldla (Ollav Folla), the founder of the Irish monarchy, as also of the palace at Tara, B.C. 700, naturally surmounts the temple. He is represented, in his capacity of monarch and lawgiver, delivering the laws to the Irish nation: with his left hand he points to heaven as the source of his authority and inspiration, while in his right he holds forth the beechen boards, on which are inscribed passages from the Brehon laws, engraved in the ancient Irish character, and of which the following is a translation. The 38th section of the Brehon laws:—

“Seven things bear witness to a king's improper conduct:—an unlawful opposition in the senate; an overstraining of the law; an overthrow in battle; a dearth; barrenness in cows; blight of fruit; blight of seed in the ground. These are seven candles lighted to expose the misgovernment of a king.”

He is seated on the *lia fail*, or enchanted stone, now reputed to be deposited in Westminster Abbey: he sits in the centre of a platform, representing all Ireland, which is mapped out under him, the coast-line exhibiting prominent scenery of the four provinces. The panel in front represents in relief the opening of the triennial convention at Tara (see *Four Masters*, page 297), in the reign of Cormac, “*Ulfada*,” or “*Long Beard*,” in the early part of the third century of the Christian era, and anterior to the introduction of Christianity into the island. Cormac sits in the centre of the hall, surrounded by ten principal officers of state, who always accompanied the monarch on state occasions, viz., the arch druid, distinguished by his long robes and wand or staff; the chief brehon, or judge, with his book of the law; and the chief noble, with his sword of state; the poet and the antiquary on the left of the monarch, with their scrolls; the state physician, with his rod and serpent coiled; the bard or minstrel, with his harp; and three stewards of the household, with wands, in the rear. The five provincial kings, with their heralds, form another circle, viz., the king of Leinster in front of the throne; the king of Ulster on the right; two kings—Upper and Lower Munster—on the left; and the king of Connaught behind the throne. The brehons, druidical priests, bards, princes, and various other estates of the kingdom, are grouped in their appointed and respective positions: the arms of the kings are affixed to the columns, and a perspective view is given of a hall 50 feet wide and 450 feet

long, crowded with the august assembly. At the opening of the triennial convention, Cormac is making a short oration, and all eyes are turned to him in silent and respectful attention.

The opposite panel represents the harpers in Tara Hall performing before the monarch and his queen, who are seated on a chair of state, with the young prince leaning across their knees; a canopy formed by the fossil antlers and skull of the giant deer supports the drapery; the sunburst is embroidered on the back; heralds and a body-guard surround the king, and three maids of honour stand behind the queen; the harpers enthusiastically strike their lyres; an opening in the drapery discovers the undulating hills of Tara, and a round tower appears in the distance; the celebrated chandelier is suspended in the hall, and a miniature decoration of musical instruments ornaments the wall; the medallion portrait at the right end of the temple is that of Onaoi, playing on his crowth, the first musician who accompanied the sons of Milesius to Ireland; the portrait on the left is Carolan, who may be regarded as the last of the Irish bards. His portrait is a copy, by permission, from an original in the possession of Sir Henry Marsh, Bart., and which is allowed to be a correct likeness; both these medallions are encircled by a wreath composed of oak, arbutus, and shamrocks. The statues at the four corners are personifications of vocal music, as it applies to war, pastoral life, the drama, and devotion.

The standards—the one emblematical of warfare, the other of pastoral life; the one presents a knight of the twelfth century leaning on his battle-axe, attracted by a lady of the court of that age playing on her guitar; a group of ancient Irish armour and weapons of war complete the standard. The corresponding one presents a country damsel with her milk-pail, and an Irish peasant, well-fitted in his dress of Irish home-made frieze. The remaining part of the standard consists of a beehive, sheaf of wheat, agricultural implements, and some of their peaceful and industrial products. The bases of the standards are engraved with ornaments from the harp of Brian Boru. The stretcher connecting the standards presents a fine decoration of ancient Irish musical instruments, accompanied on either hand by the mermaid and banshee, whose songs and cries afford large subject-matter for the old Irish poems, ballads, and legendary tales. The lower stretcher is ornamented in the centre by a bunch of shamrocks, embosomed in the heart of which are the letters V. and A., tied by a true lover's knot, and the date 1851 inserted. The four curious antique letters E. R. I. N. are copied from ornamental capital letters in the Book of Kells—one of the most ancient Irish manuscripts.

The whole subject forms a sort of chronological series,

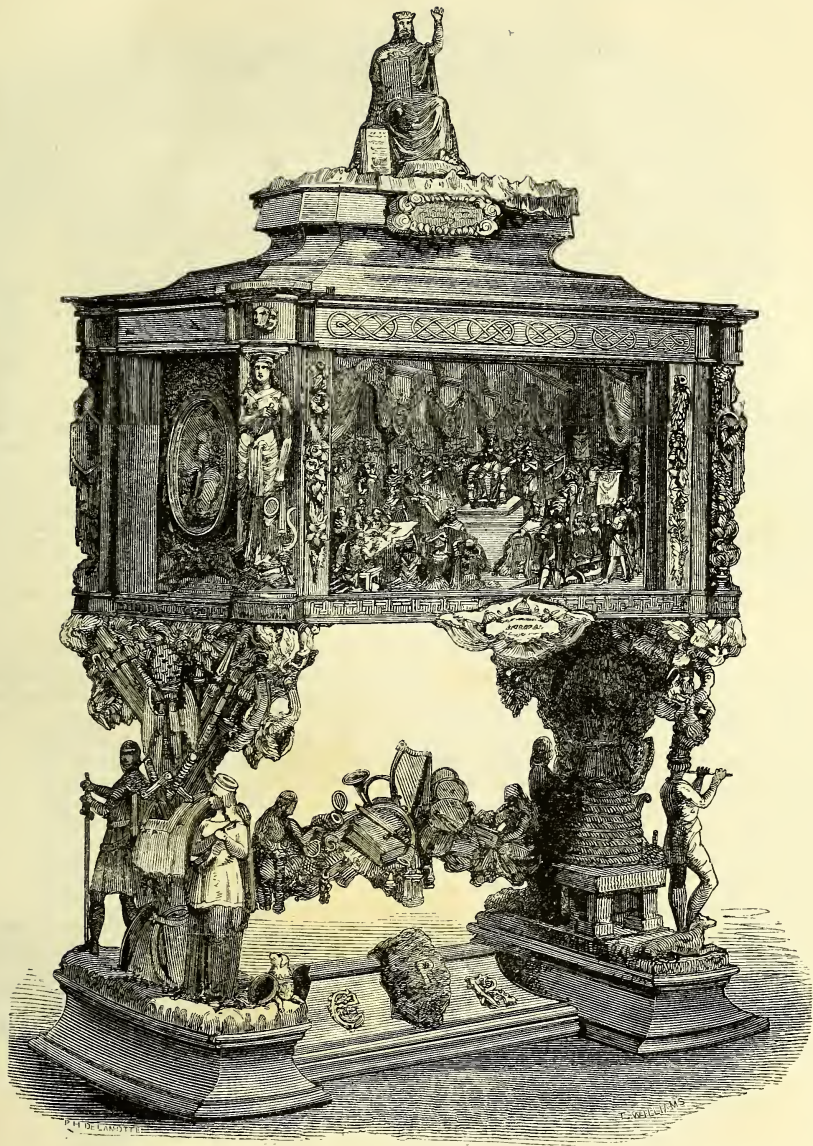

CARVED MUSIC TEMPLE, IN BOG-YEW. MR. J. A. JONES. DUBLIN.

commencing 700 years B.C., the date of the foundation of the Irish monarchy—touching the flourishing state of the kingdom under Cormac—passing through the chivalric age of the crusaders, and ending with the present agricultural age of Ireland—the memorable year 1851.

79 MECHI, JOHN J., 4 *Leadenhall Street*—Manufacturer.

Articles in Coromandel wood, Spanish mahogany, rose-wood, ebony, papier maché, Russia leather, &c., ornamented with gold, silver, cut glass, mother-of-pearl, carving, &c.

An ornamental and inlaid bagatelle table, represented in the following engraving.

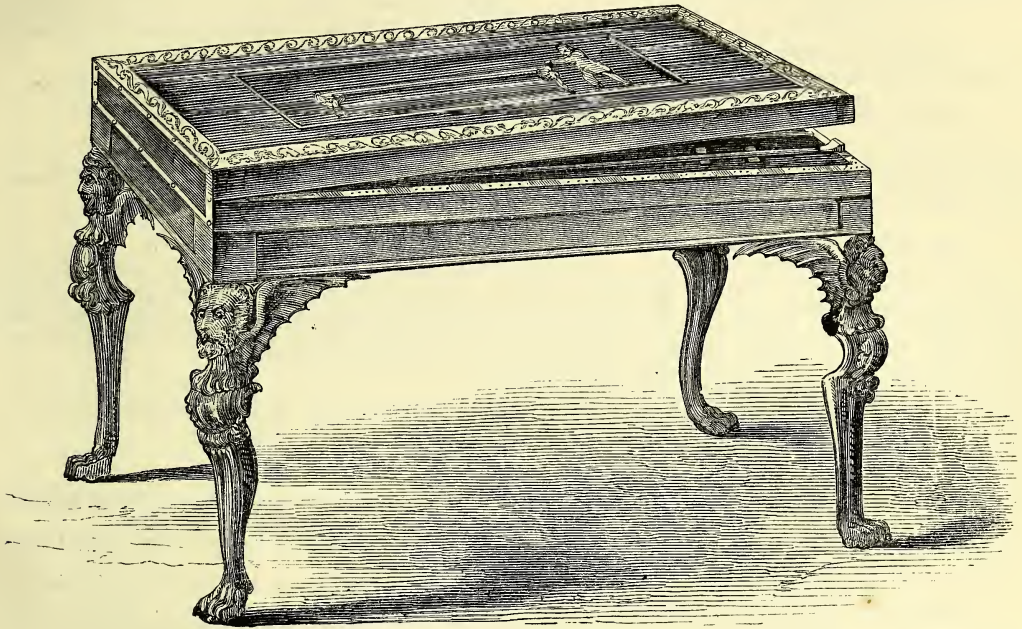

Mechi's Ornamental and Inlaid Bagatelle Table.

A lady's work-table, fitted with every requisite, and highly ornamented, represented in the next engraving.

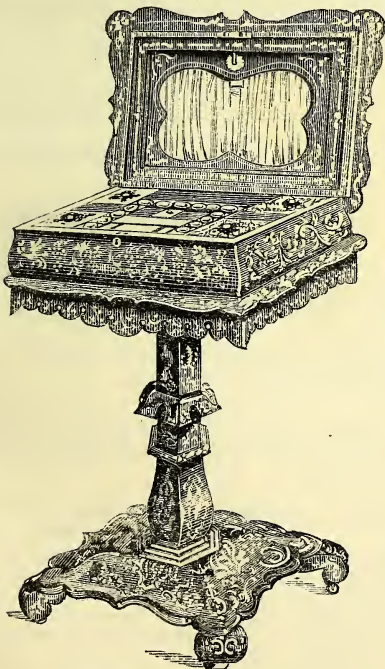

Mechi's Ornamental Work-table.

Writing and dressing cases, work-boxes, work-tables, tea-chest, despatch-box, stationery-cabinet, knitting boxes, &c.

80 MEDCALE, FRANCIS, 98 *Bride Street, Dublin*—Designer and Manufacturer.

Cabinet of oak, grown on the estate of Earl Fitzwilliam, Coolatin Park, county Wicklow, with top of Connemara marble, from the quarries of Ballinahinch, county Galway. The standards represent the Genius of Painting, with palette and brushes; Sculpture, with unfinished model; Science, with compass and chart; and Literature, with open book and pen; supported on shoots of palm. The branches continuing round the frieze are entwined with fruit, flowers, &c., to the centre, and hang in festoons at each end. In the centre of the frieze is represented "The Choice of Hercules;" on the back Peace and Plenty supporting a wreath of shamrocks, medallion likenesses of H.M. the Queen and H.R.H. Prince Albert, surmounted by Fame, and at the ends are Commerce and Industry.

81 MOLLOY, THOMAS, *Ballena, Dublin*—Producer.
A rustic chair.

82 CALVERT, GEORGE (late Burman & Calvert),
Huddersfield—Painter.

Painted decoration in imitation of mahogany, oak (light and dark), satin-wood, and maple.

83 AGGIO, G. H., *Colchester*—Producer.

White and gold ottoman, embossed wood and silk, in glass case.

84 FLETCHER, EDWIN, *Royston, near Barnsley*—Designer and Manufacturer.

Washable paper-hangings, colours, granites, marbles, and stone.

85 HOLD, AMOS, *Ardley, near Barnsley*—Designer and Carver.

Pine frame for looking-glass, carved with fruit, flowers, and birds. English oak letter press, carved with a bunch of grapes.

87 ALLAN, D., *Sloane Street, Chelsea*—Inventor.

The registered melior; an appendage for chairs, to hold gloves, fans, bouquets, &c., while ladies are at dinner.

88 GAUNT & SON, *Wortley, near Leeds*—Inventors and Manufacturers.

Decoration for library, dining, and drawing rooms. Durable and fixed colours.

89 LAW & SONS, *Monkwell Street*—Manufacturers.

Specimens of decorative paper.

90 COLLINSON, GEORGE CROYSER, *Doncaster, Yorkshire*—Manufacturer.

Hall or library chair, of fossil oak, found in making a cut from the river Don, near Doncaster, Yorkshire, in 1848; carved to represent oak branches, leaves, &c.

91 INNES, ELIZABETH & SUSANNA, *Castle Street, Montrose, Scotland*—Designers.

Screen, with rosewood frame, four feet four inches high, the glass thirty-three by twenty-five inches. The screen is white watered silk, with wreaths and basket of flowers, intended to display the colours and plumage of the feathered tribes. The design is new; the flowers represent a variety of different kinds, from the passion-flower to the snow-drop. The plumes that adorn the little crown near the top of the screen are obtained from the crest of the peacock. The feathers in the screen are all obtained from birds of the county of Forfar. The frame was made by Messrs. F. J. & F. Japp, Montrose.

92 DINHAM, ANNIE, *Camelford*—Proprietor.

Fancy work-table, veneered with tulip-leaves.

93 CAMERON, G., 11 *Shepherd's Market, Mayfair*—Producer.

Specimens of decorations.

95 HASELDEN, WILLIAM, *Chelsea*—Designer.

Specimens of designs for paper.

96 CRAWFORD, JAMES, 242 *Stobcross Street, Glasgow*—Designer, Inventor, and Manufacturer.

A mirror, composed of plane tree, made by the exhibitor.

97 NEWTON, W., 226 *Argyll St., Glasgow*—Proprietor, Designer, Inventor, and Manufacturer.

Loo-table, composed of nearly 7,000 pieces of foreign woods. Several relics in pieces of wood from the Royal George, old London-bridge, Wullie's-mill, birks of Aberfeldy, broom of Cowden Knowes, Queen Mary's box, old Glasgow-bridge, 500 years old, Glasgow cathedral, &c.

Table, composed of 18 different kinds of wood, all the pieces are inlaid.

Chiffonnière, composed of above 4,000 different pieces and 18 different kinds of foreign woods, representing the Queen and Prince Albert. Fourteen relics of wood.

Tea caddy, with profile of Her Majesty at 18 years of age, composed of 1,340 pieces of wood.

98 IMBIE, PETER, *Perth*—Manufacturer.

Circular loo table, on pillar and claw, made of the root of a larch tree raised near Murthly Castle, Perthshire.

99 ALEXANDER, JOHN TOD, *Maxwelltown, Dumfries*—Producer.

Ornamental garden chair of roots and branches of the oak.

Picture-frame of roots and branches of the laburnum-tree, for a Scotch romantic scene, with huntsmen and game.

100 HAY, J. & J., *Aberdeen*—Designers and Manufacturers.

Gilded and emblematic national picture-frame.

101 SCRYMGEOUR, HENRY, *George Street, Edinburgh*

—Designer and Manufacturer.

Model for a British state bed, with canopy, Elizabethan style. The entire framework of the bed with canopy is carved in pine and plane tree, and the materials used in the upholstery are chiefly of Scottish manufacture. The blankets are of the finest Cheviot wool, and the sheets of finest Tweed linen. The canopy is made to extend at pleasure, and is shown partly extended. The roof is ventilated by tubes, terminating in the cross at the top of the crown.

102 WARRACK, HARRIET, *Dee Street, Aberdeen*—Designer.

Ornamental fire-screen.

103 KER, W., *New Inn Yard, Tottenham Court Road*—Producer.

Table and table top, inlaid.

104 BARRIE, JOHN, *Edinburgh*—Designer and Producer.

Carved book-tray, executed by a ploughman, in the evening, by candle-light, after working hours without the aid of any model or design, the use of any instrument or machinery, but a penknife.

105 WOOD, J., *Collingwood Street, Blackfriars*—Producer.

Table-top, &c. in marquetric.

106 LITHGOW & PURDIE, 60 *Hanover Street, Edinburgh*—Designers and Producers.

Specimen of panel for a decorator's saloon; style—Renaissance.

One ceiling and two wall panels for an ingoing; style—Louis Quatorze.

General design of corridor, for which the preceding articles were executed, showing the position of the details.

Sketch for drawing-room decoration; style—Pompadour, time of Louis Quinze.

Drawing-room decoration, painted in distemper—The seasons.

Drawing-room ceiling, painted in distemper; style—Rococo.

Two painted chess, in imitation of mosaic and buhl.

Panel in imitation of buhl; decoration for library walls, &c.

Decoration in imitation of inlaid marbles, for entrance halls, &c.

107 ROSS, DANIEL, 11 *Norton Place, Edinburgh*—Producer.

Carved oak sideboard, with a figure on each door, representing Plenty, and one on the back surrounded by fringe and foliage. Strong portable chair.

108 BONNAR & CARFRAE, *Edinburgh*—Manufacturers.

Specimens of painted decorations.

109 CARSON, WILLIAM, *Stirling, Scotland*—Designer.

Specimens of wood painted in imitation of mahogany, maple, and oak.

110 FRENCH, GILBERT J., *Bolton*—Designer, Producer, Manufacturer, and Proprietor.

Velvet cover for communion-table, with cushions, service-books, carpet, and wall-hangings; the ornamental devices are of the period of the Reformation. Altar vestments of crimson velvet, with corresponding kneelers, service-books, linens, and wall-hangings. Episcopal chair, after an ancient example in York Minster. Fair linen cloths, for communion-table, damasked. Ecclesiastical banners of the provinces of Canterbury and York. Kneeling hassocks for benches and pews. Heavy curtains for church-doors, to supersede inner doors.

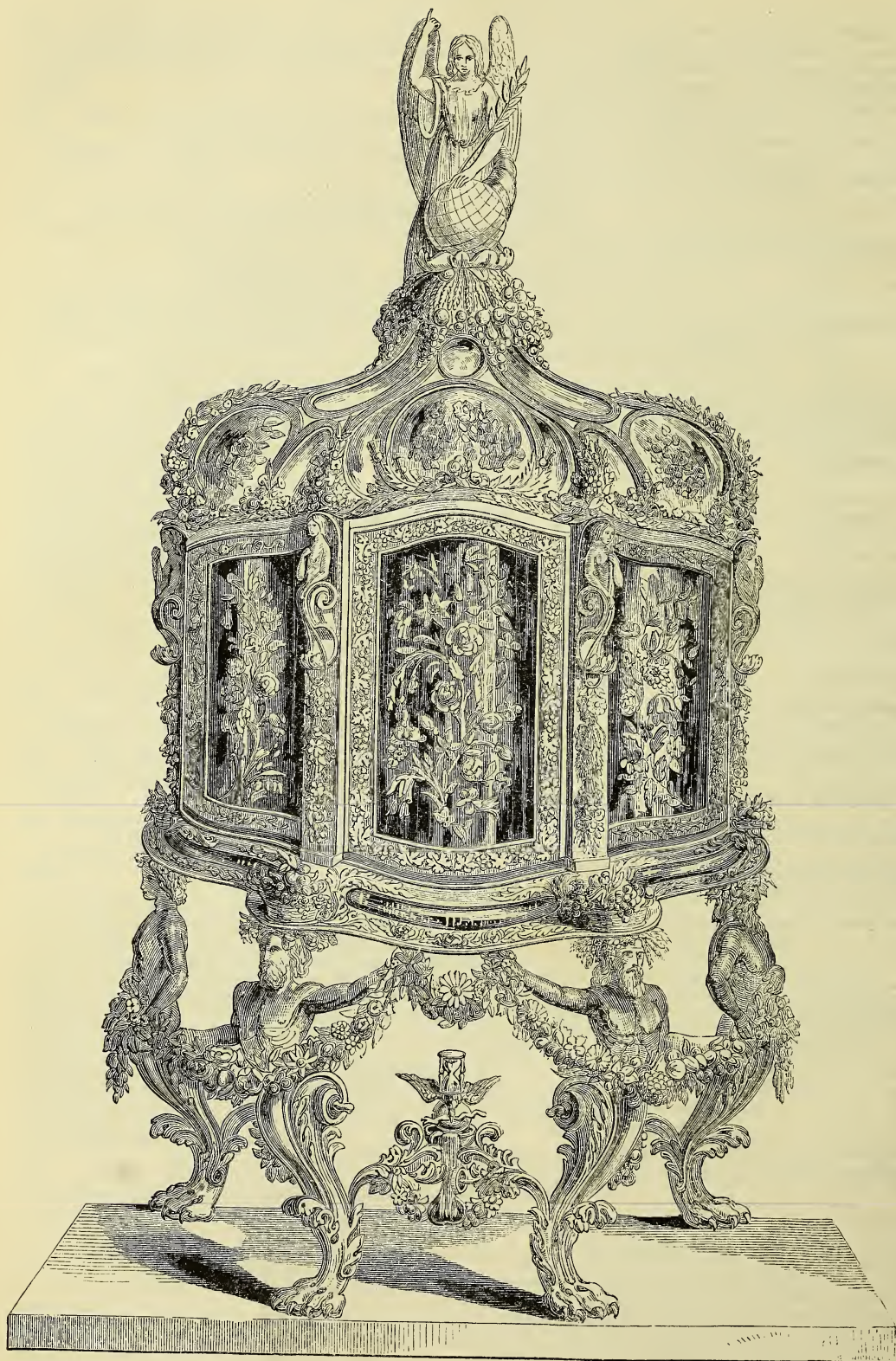

111 TILLING, E., *Bradshawgate, Bolton*—Manufacturer.

Ornaments made of a new combination of known materials for interior decorations for ceilings, walls, picture-frames, window-cornices, &c., exhibited for tenacity, lightness, and facility in working.

112 BLAND, MATTHEW, 2 *Broad Street, Halifax*—Designer and Manufacturer.

Sideboard, ornamented in representation of the vine.

113 KING, WILLIAM ATKIN, *Whitchaven*—Designer, Inventor, and Manufacturer.

Aldobrand Oldenbuck's Cabinet, from Sir Walter Scott's story of *The Antiquary*, made from three varieties of British oak grown in Cumberland.

114 CARMICHAEL, JOHN, *William Street, Workington, Cumberland*—Designer and Producer.

Carved oak chair of novel design, with birds and foliage; the arms two rampant lions, cut out of the root of oak; the seat and back covered with crimson velvet, and embroidered by George Haines, Esq., Grosvenor Row, Chelsea.

115 MILLS, T., *Bradford, Yorkshire*—Designer and Manufacturer.

Hall table and hat-stand combined; table supported by two Roman winged lions, with carved front, marble slab for top, umbrella recess, and water receptacle. The whole cut in solid mahogany, and decorated with other ornaments.

Drawing-room chair, carved in solid mahogany and gilt; ornamented at top with the rose, thistle, and shamrock; having the seat covered with fine satin damask; with a bouquet of flowers woven in silver.

116 DREW, D., *Truro, Cornwall*—Producer.

Rustic table and two stools.

117 HARROLD, THOMAS, *Hinchley, Leicestershire*—Manufacturer.

Table with revolving top, made of a curiously gnarled oak, grown in Warwickshire, supposed to be many centuries old. Upwards of six hundred figures fantastically formed by the natural curl in the grain of the wood appear on the surface of this table. In the centre a group, supposed to resemble Adam and Eve, the Serpent, and the Tree.

118 WOOD, JOHN, 59 *Milk Street, Bristol*—Manufacturer.

Marquetrie table of inlaid woods, containing a representation of the battle of the Nile. This table is 5 feet in diameter, the body being composed of walnut wood, and the inlaid pieces comprising a great many varieties of wood, few of them being dyed. It contains a picture of the Greenwich pensioner describing the battle, the flags of the various British ships engaged, and some of the vessels displayed in action; also Fame crowning Nelson.

120 MATHIESON, R. R., *Stirling, Scotland*—Designer.

Plain deal lobby-table top, painted in imitation of various marbles. In the centre are the Royal arms; in the angles those of the Duke of Argyll, the Duke of Montrose, the Marquis of Breadalbane, and the Earl of Marr; on the inner panel, those of Lord Abercrombie and the Provost of Stirling.

121 GRUNDY, J. CLOWES, 4 *Exchange Street, Manchester*—Designer and Manufacturer

Frames in gold, designed for the engravings of Sir Edwin Landseer's "Peace and War."

A frame designed for water-colour drawing, with tinted spandril to suit the subject; adapted for drawing-room or boudoir.

A frame designed for a tableau of studies of various styles by an artist in water-colours, and adapted for drawing-room or boudoir.

A frame designed for two drawings of different forms, in two compartments. A frame designed for a single drawing, differently ornamented, with tinted mat. A circular table, in gold, the top of which displays seventy-four landscapes, painted in oil by J. B. Pyne—views from nature, the centre one being a view of Clifton. A frame, composed of the vine, adapted for fine engravings. A frame designed for Sir Edwin Landseer's portrait of the Queen and children. A light panel frame, with tinted spandril, designed as a simple frame for water-colour drawings. A semicircular topped frame for drawing-room, composed of lilies of the valley, &c. A frame for drawing in chalk (*Lady Blessington*, by D. Maclise, R.A.), with flower sides. A frame designed for Lawrence's engraved portrait of Sir R. Peel. A light frame, with ivy entwined, adapted for chalk drawings. A panel frame (for study of "Manchester," by D. Cox), showing tinted mat inside. A frame adapted for old-master drawings, composed of fruit and flowers. An elliptical frame, designed for Eastlake's "Christ weeping over Jerusalem." A frame designed for Raffaele's "Madonna della Seggiola," with lily top and palm base. A light panel frame, with tinted mat, for drawings. A small frame, intended for portrait of Burns.

121A GRUNDY, JOSEPH LEEMING, 130 *Regent Street*—Proprietor.

Portfolio, chair, and prie-dieu, made of walnut-tree.

122 DOVESTON, GEORGE, 106 *King Street, Manchester*—Designer and Manufacturer.

Ebony bookcase, carved in relief, with brass door frames, and plate glass; the frames made by Messrs. Cope and Collinson, of Birmingham.

Boudoir chair of carved ebony, upholstered and covered with crimson silk velvet.

Bijouterie cabinet in tulip and king woods, with Sèvres china panels in doors.

Occasional table in walnut and tulip woods, with marquetrie top.

Shaped circular table, in marquetrie and tulip wood.

123 MOUSLEY, C. E., *Hamton Hall, Tamworth*—Producer.

Mahogany table-top 14 ft. 3 in. by 5 ft. 3 in. wide, in one slab.

124 STEEVENS, JOHN, *Taunton*—Designer and Manufacturer.

Carved and ornamented cabinet.

This cabinet represents, in four male figures, the periods of youth, manhood, maturity, and old age, whilst other four (female) figures are representative of the seasons. All the figures are rendered complete by a carved lion's foot at the bottom of each, and above the feet is a connecting frame to make that portion of the stand perfect. Between the figures of Spring and Summer are carved flowers and fruit in profusion, emblematical of the seasons; it represents the all-important fact that time flies, by an hour-glass borne on the wings of a splendidly-carved eagle, and suspended from the bird's beak are the letters, curiously wrought, forming "Tempus fugit." This rests on a globe, representative of the earth, which is half sunk in a shell of water, overflowing the wheel of time, and shedding on fruit and flowers its refreshing dew. The space between the figures of Autumn and Winter is filled with carvings of the chrysanthemum, holly, ivy, and autumn fruit, entwined with consummate skill and taste. The garland, or festoon, which is carried through, and sustained as before stated by each of the four figures, is composed of every flower indigenous to Taunton, and introduced emblematically to the time in which they severally bloom.

Above the figures, and resting on their heads, is a stand or frame to receive the top part containing the drawers, doors, &c. Over the head of Youth, in this frame, is a basket of strawberries, cherries, raspberries, and early fruit, surrounded with leaf-work, enclosing a panel of needlework, covered with bent plate glass.

Over the head of a carved figure, representing Summer, is a basket, containing currants, strawberries, gooseberries, apples, pears, peaches, and other fruits, enriched with leaf-work, the lily and the rose completing the centre. Between the Summer and Autumn baskets and a panel are mottoes.

The autumn basket contains grapes, pears, filberts, &c., surrounded with leaf-work. The panel of needlework next appears for Winter, and over the head of the winter figure, is placed a basket of walnuts, medlars, &c. The cabinet contains about eighty drawers, in fine walnut wood, enriched with fuschia drops in silver, and coral beads for drop handles; the wood work is relieved with silvered plate glass, also small doors with plate glass for needlework, in wild flowers. This completes the interior of the frame.

The exterior represents three carved doors, in fine relief: over Spring and Summer is the convolvulus, entwined round the frame; then follows the centre door, in fine relief; the grape vine full of fruit, being very prominent. The door over Autumn and Winter is enriched with carvings of barley and hop vine. Between each of these doors are pilasters, forming four female figures, holding in their hands the emblems of the seasons. A newly-invented glass dome head, for the protection of knitted flowers in Berlin wool. The woodwork springs from each group of flowers over the heads of the female figures, with mouldings to receive the bent plate glass, and is enriched with fine carvings of fruit and flowers. At the extreme top of this glass dome stands a figure of Peace, with extended wings, bending over the globe, holding in one hand the olive branch, and with the other pointing upwards to heaven. The needle-work, executed on black velvet, from nature, by Miss Kingsbury. This cabinet is represented in the annexed plate, No. 138.

Four specimens of table-tops, made of English oak grown near Taunton, Somerset. Sideboard top, of the same material.

125 BAMPTON, JOHN AUSTIN, 49 *Union Passage, Birmingham*
—Inventor and Manufacturer.

Specimens of a material produced from the mixture of moss or peat, in certain proportions, with sawdust, &c. It is subjected to a pressure of 800 tons, to make it fit for use; it then becomes hard and durable, and capable of being polished and worked.

Plastic material made from moss and lime, which has been submitted to a heat of 160 degrees without showing any crack or flaw; it can be used in a sheet or plastic state. Gypsum and cements may be used in producing similar articles. Specimens of compressed moss fibre.

[It has long been known that moss or peat, either alone or mixed with other vegetable or mineral substances, was capable of great compression, and sometimes exists in nature in an extremely dense, hard, and brittle state. In the manufacture of the materials above mentioned, advantage has been taken of the force of cohesion by bringing the particles of bodies into close contact under enormous pressure.—D. T. A.]

127 CLARKE, JOHN, *Birmingham*—Designer and
Painter.

Heraldry painting; specimens showing various curious designs of armorial bearings, including seventy-four coats of arms and crests.

128 LANE, T., 91 *Great Hampton Street, Birmingham*
—Manufacturer.

Articles chiefly in "patent pearl glass." Papier maché table, with inlaid border of mother-of-pearl and landscape and figure centre. Work-table, ornamented in pearl and gold. Cheval screen papier maché frame, with centre, flowers on white ground. Pole-screens. Reading-table. Cabinets on stands. Chess-table, &c.

Panels for ship cabins, rooms, and other decorations.

Specimens of patent gem painting on glass; invented by Miss E. Tonge, Boston, Lincolnshire.

[The patent pearl glass is distinguished by the richness of effect consequent on the introduction of the laminae of mother-of-pearl behind the glass on which the picture is executed; the picture is painted on the reverse side of the glass to that exposed, the parts being left blank or slightly coated with varnish, close behind which the pearl is introduced as a means of decoration.

Gem painting is also executed upon or behind glass, and much of its brilliancy arises from the obscuration around of the glass not ornamented; the reflective surface in this case is a metallic foil, and the depth of colour is heightened by transparent varnish colours.—W. C. A.]

129 DAVIES, GEO. C., 7 *Brearly Street West, Birmingham*
—Designer and entire Producer.

Papier maché work-box, decorated in the Elizabethan style; illustrated with glass tablets of the monarchs from the Conquest; the tablets are partly painted, and partly transparent; the brilliancy of colour produced by stained polished metals.

Japanned papier maché box.

Glass tapestry panel, a new style of decoration for rooms, furniture, &c. Painted in transparent colours, backed with white and coloured satins, &c.

130 GILBERT, W., & Co., 114 *Kingsland Road, and*
26, 27, 28, *Fleming Street*—Manufacturers.

Economical invalid bedstead, exhibited for simplicity, ease, and cheapness; invented by the exhibitors.

Six globes, containing a series of feathers, quills, &c., illustrative of the exhibitors' chemical process of purifying feathers, viz.:—1. Fine dust, as created by insects. 2. Pieces of quills, &c., as destroyed by insects. 3. Feathers not purified. 4. Feathers purified. 5 & 6. New feathers not liable to decomposition.

131 HALBEARD & WELLINGS, 45 *St. Paul's Square,*
Birmingham—Manufacturers.

Papier maché toilette table of Elizabethan design, inlaid with pearl, and mirror corresponding with table. Loo table, embellished with group of English wild flowers and foliage. Occasional table, group of flowers, inlaid with pearl. Ladies' work-tables.

Large cabinets, inlaid with pearl ornaments, and embellished with painted vignettes. Albums, bound in papier maché boards, inlaid ornaments, and decorated with pearl flowers. Portfolios, various ornamental designs. Tea trays, various patterns.

Series, illustrating the different stages of manufacture from the raw material to the finished article.

[There are two varieties of papier maché: the best is produced by pasting together, on an iron or brass mould, a number of sheets of paper of a spongy texture, allowing them to dry between each addition. In the common variety, the paper is reduced to a pulpy substance, and the form is given by pressure into matrices of metal. Papier maché may be formed into any desired article by means of the lathe, the plane, or the rasp; it is several times varnished; and the irregularities of surface are removed by scraping and rubbing with pumice-stone. The artist then introduces the design; it is again varnished, and polished with rotten-stone; and its final brilliancy is given by rubbing with the palm of the hand.—W. C. A.]

132 FOOTHORAPE, SHOWELL, & SHENTON, *Birmingham*
—Manufacturers.

Ladies' work-tables, with design, Buckingham Palace, and flowers and fruit, in pearl. Drawing-room ornament-stand. Reading and work table. Small cabinet, with flowers and fruit, in pearl. Writing-desks and ladies' work-box, pearl inlaid.

Jewel-boxes, with Windsor Castle, and flowers, in pearl. Folios, with flowers in pearl. Large inkstand, arabesque. Ladies' dressing-case. Card trays, inlaid pearl. Tea-chest and caddy, pearl inlaid. Card-case, odour-box, netting-box. Ladies' reticule. Pair of hand-screens. Set of trays.

133 LEE, L., 118 *Bedford Street South, Liverpool*—
Producer.

Fancy table, painted in enamel on prepared wood; centre, a group of flowers, with gold border.

134 THOMPSON & WORTHY, *Durham*—Manufacturers.
Ladies' writing desk.

135 DAWES, BARTHOLOMEW, 20 *Carlisle Street, Soho Square*—Manufacturer.

Octagon loo-table. Small circular chess-table. Circular table with top, made of a rare species of cedar.

Lady's toilet-table of tulip-wood, inlaid with purple wood, fitted with china wash-basin, and drawers, the centre inclosed by a pair of doors, silvered glass panels; a statuary marble top, moulded edges, shaped back, with swing-glass in centre; wrought panels on either side, with oval glass, mounted with or-molu in the renaissance style.

Toilet chair of tulip-wood, &c., to correspond, with stuffed seat and back covered in silk, &c.

A carved mahogany stand, with china basin. A carved mahogany cupboard.

Models of the patent outside sun-shades.

136 McCALLUM & HODSON, 147 *Brearley Street, Birmingham*—Manufacturers.

Papier maché table, inlaid with pearl flowers, fruit, and ornaments.

Papier maché sofa tables; one with the Exhibition Building introduced.

Multiformia, music-stand, table, fire-screen, or reading stand, "St. Cecilia." Card-tray, and flower-stand or table.

Cabinet on stand, comprising chess and backgammon-table, ladies' work-table, writing-desk, and fitted for jewellery, coins, and writing requisites.

Articles in papier maché: cheval screen. Card-plate. Ladies' portfolio, chair, table, and pier-glass, inlaid. Ladies' work-table.

Barometer, illuminated with pearl. Bracket-glass with branch-lights.

Ladies' work-boxes, with paintings, "The Antiquarian" and "Pearl-flowers." Ladies' jewel-case, "doves and fountain;" dressing-case, view of Windsor Castle; and writing-desks, inlaid pearl flowers and shells, &c.

Gothic card-box, inlaid; and cabinets, with view of Warwick Castle; work-basket and tea-chest, view of Alhambra, inlaid.

Tea-caddy, pearl flowers, landscape, &c. Papeterie. Cruet-stand, pearl ornaments. Inkstand.

New tray, Queen's shape; new oval Gothic tray, Albert shape.

[The inlaying of pearl in "papier maché" is a simple process, and does not consist, as some might suppose, and as the name indicates, in cutting out the material and inserting the substance inlaid; it is held simply by adhesion, and its application may be thus described:—the pearl-shell cut into such pieces or forms as may be desirable, is laid upon the article to be ornamented, a little copal or other varnish having been previously applied, the pieces of pearl at once adhere to it; thereafter repeated coats of tar varnish fill up the interstices and eventually cover the pearl. This extra varnish is renewed, a uniform surface is produced, and the pearl exposed by rubbing with pumice-stone, polishing with rotten-stone, and finally "handing."—W. C. A.]

137 SUTCLIFFE, I., 27 *Great Hampton Street, Birmingham*—Manufacturer.

Ornamental papier maché trays, in various styles and sizes.

Papier maché loo-table, with subject, "Ruins of Carthage." "Louis Philippe" and round papier maché tables.

Chinese papier maché vases, with figures and gold ornaments.

Papier maché folios, caddies, work-boxes, inkstands, &c.

138 TURLEY, RICHARD, *Birmingham*—Manufacturer.

Large folding screen, exhibiting a combination of landscapes, fruit, and flowers. Large loo-table with pearl wreaths, and painted landscape and cattle. Oval table with gold ornaments and flowers introduced.

Gothic tables, with fruit and flowers, "The village gate;" vine border and painted centre, "The Round Tower of Oberwesel."

Hexagon table, "The Wellington Shield." Round table, with painted landscape, "The windmill."

Large and small cabinets. Inkstands. Ladies' reticule. Ladies' perfumery cases. Tea-chest and caddy. Clock case and watch-stand. Music-folio, vine-border. Portfolio and writing-desks, all ornamented with pearl and gold, &c.

Large tray, intended to show the beauty and durability of the papier maché, it being more than thirty years since it was produced.

Tray, antique shape, centre design copied from the Nimroud Sculptures in the British Museum.

Oblong antique Gothic tray, gold border. Ladies' work tables, ornamented with pearls, flowers, gold, and painting. Card-box. Dressing-cases. Cake-baskets.

Chairs, scroll back, pearl and gold, and Elizabethan shapes.

New Gothic table, painted centre, "Das Königliche Schloss, in Berlin." Writing desk, "Das Königliche Schloss, in Charlottenburg." Music-books, view, "Das Neue Palais in Potsdam," and "Das Königliche Schloss in Potsdam." Two small cabinets, pearl and gold. Inkstand, flowers and gold. Portfolio.

Hand-screens—"Jenny Lind," "Sims Reeves." Telescope hearth-brush, patent slide toasting-fork, patent swivel. Pair of bellows, flowers and gold; another pair, painted landscape. Large and small vases, flowers and landscape. Portfolio—"Age of Innocence."

139 HOPKINS, ROBERT PIKE, *Wimborne, Dorset*—Designer.

Open fancy brass front-door knobs, dead and relieved, and lined with black china, and blue and white opal glass. Finger-plates, lined with silvered enamelled blue glass.

140 BROWN, JOSEPH, 71 *Leadenhall Street*—
Manufacturer.

A ship's bedstead.

141 SMITH, GEORGE F., *March, Cambridgeshire*—
Designer.

Specimens of painting, in imitation of various marbles, which are finished while the colours are wet. Intended as a substitute for marble in the construction of chimney-pieces, inlaying of tables, &c.

Painting, in imitation of oak, intended as a substitute for the wood in decorations.

142 SCHOLEY, Misses, 36 *Westbourne Terrace*—
Producers.

Gilt chair and stool, embossed in wool and silk.

143 DAVIS, GEORGE, *Southampton*—Designer and
Manufacturer.

Specimen of marbling, graining, painting, and varnishing, on paper. There is no smell of paint or varnish, in using it, and a room may be completed in one day.

144 GORE, GEORGE, *Speenhamland, Newbury*—Designer and Painter.

A four-leaved folding screen, painted in the old English illuminated style, recording the most remarkable events of English history from the Conquest to the present time, and containing on the panels representations of various royal badges and arms, with those of the City of London.

145 BELLEABY, WILLIAM, *York*—Designer.

Cabinet of oak, having panels of burnt white wood, with subjects executed (by a manipulation analogous to carving and mezzotint engraving), viz., the "Descent from the Cross," after D. Riccairelli da Valterra, and "Bearing the Cross," from Raffaele d'Urbino.

146 FINDLEY, CHARLES V., *36 King Street, Leicester*—Designer and Manufacturer.

Carved chair of English oak, Leicestershire growth.

147 BARKER, GEORGE, *2 Brook Street, Bond Street*—Inventor.

Perforated flexible screws, with nuts and hooks, for hanging pictures, at any required height.

148 MEAKIN, J. F., *Baker Street, Portman Square*—Manufacturer.

Registered chair.

149 COTTERELL BROTHERS, *Bristol*—Manufacturers.

Specimens of paper-hangings for a dining-room.

150 WELSH, THOS., *Farm Street, Birmingham*—Designer.

Lady's cabinet, in papier maché.

Writing-desk, toilet and jewel case, and work-box.

151 FLETCHER, RAYMOND, *Derby*—Inventor.

Crystal granite paper-hangings, adapted for halls, stair-cases, &c. These admit of being washed.

152 RAMUZ, ALEXANDER, *17 Frith Street, Soho*—Producer.

Patent mechanical billiard dining-table, capable of being adapted to persons of any stature; also convertible into a dining-table.

Patent sofa, containing a mahogany bedstead, covered in green Utrecht velvet.

Model of a double bedstead. Model of a double ottoman. Model of a ship's bed, to modulate the motion of the vessel, and prevent sea-sickness.

153 RIVETT, WM., & SONS, *50 Crown Street, Finsbury Square*—Designers and Manufacturers.

Mahogany pedestal sideboard.

154 HOPKINS, W., & SON, *Birmingham*—Manufacturers.

Shade, with improved action, stops at any point, without the aid of hooks, is moved up and down with one cord, and is not liable to get out of order.

155 MINTER & Co., *Stoke-upon-Trent*—Producers.

Two busts in marble.

157 BIELEFELD, CHARLES FREDK., *15 Wellington Street, Strand*—Inventor and Manufacturer.

Papier maché articles, manufactured by patent machinery. Large Corinthian capital. Bracket with figures. Royal arms. Dragon and eagle.

Bust of Flaxman. Bracket figure of an angel, glass frame, and girandole; with a variety of architectural ornaments, and embossed mouldings. Corinthian capital.

159 GREIG, EBENEZER, & SON, *27 Farringdon Street*—Designers and Manufacturers.

Winged wardrobe of fine Spanish mahogany, with internal fittings, carved pediments, trusses, doors, &c. This wardrobe is represented in the annexed engraving.

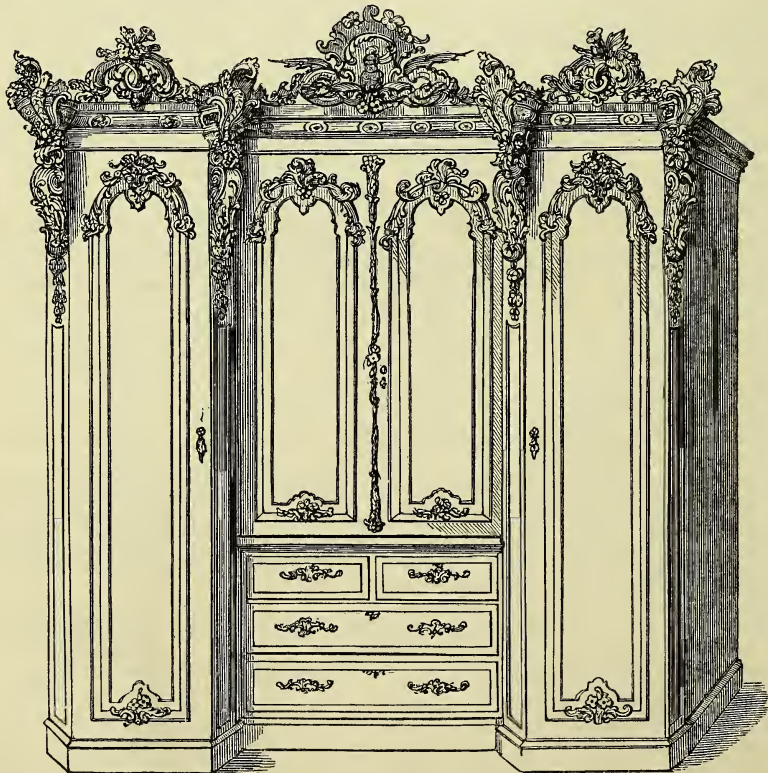

Greig's Winged and Carved Mahogany Wardrobe.



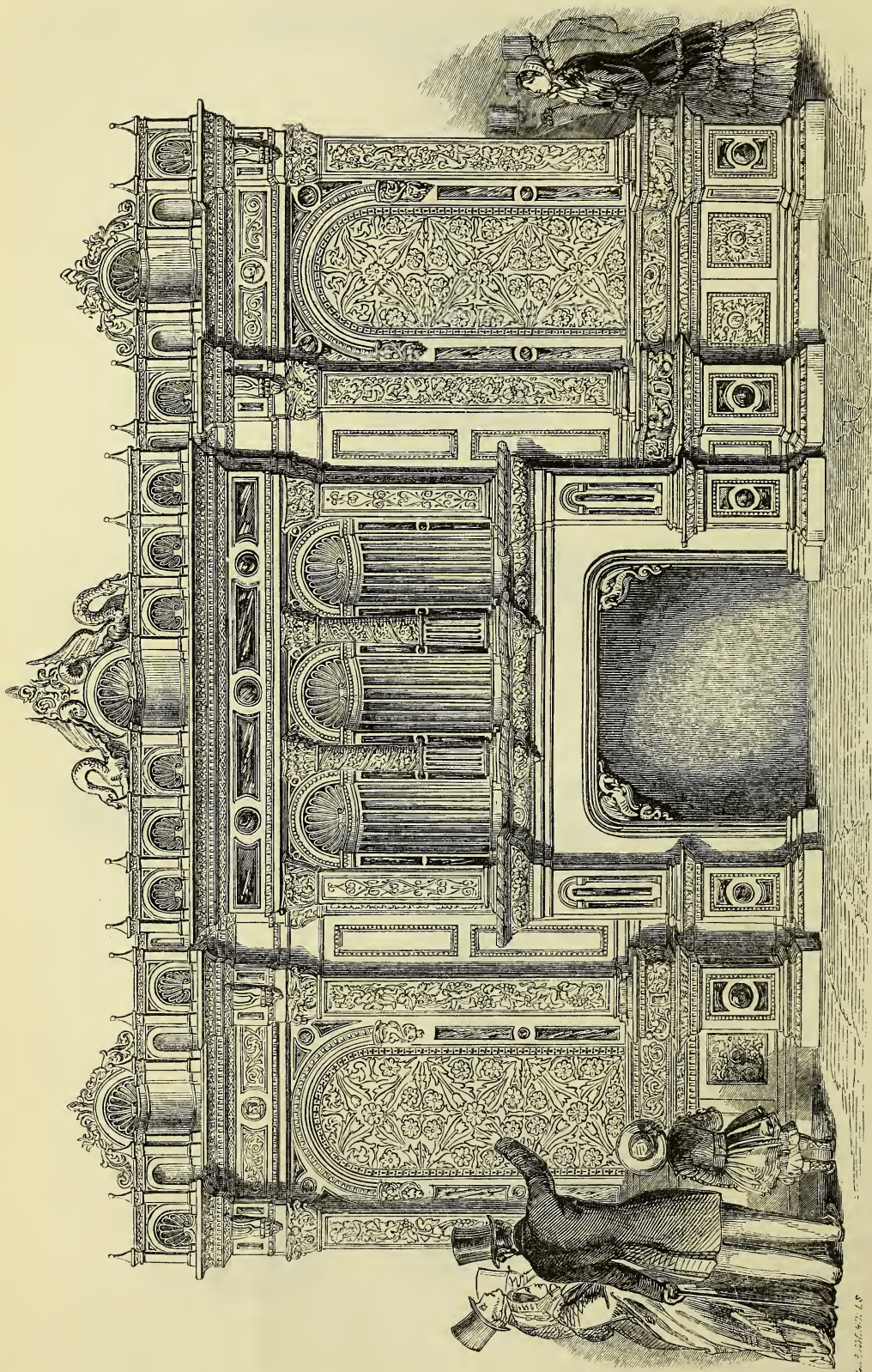

CABINET MADE FOR HER MAJESTY. MESSRS. HOLLAND.

160 WILLS & BARTLETT, *Kingston-on-Thames*—
Producers.

Bookcase, of walnut-tree, combined with other woods in relief.

Pair of candelabra, the materials being a combination of three woods, in their natural colours.

161 HOLLAND & SONS, 23 Mount Street, Grosvenor Square, 19 Marylebone Street, St. James's, and Ranelagh Works, Belgrave Square—Manufacturers.

Bookcase, or decoration of a library, founded on the cinque-cento style, with application of natural forms, composed of British woods and British marbles; from designs by Macquoid. Plate 1 represents this bookcase, which has been executed for Her Majesty.

Console table and glass, the glass representing a lake, with water-plants surrounding, and water-fowl as supporters.

Water-lily circular table. Bed, or sofa.

Bed or sofa reading-desk, to assist invalids and others; invented by Captain Twopeny, jun., U. S. C.

162 TROLLOPE, GEORGE, & SONS, 15 Parliament Street, Westminster—Designers and Manufacturers.

Decoration for a ceiling, painted in encaustic.

Sideboard, elaborately carved in oak, the lower panels representing groups of game, fish, flowers, and fruit; the frieze illustrative of the chase, supported by figures and trophies emblematical of the seasons. The annexed illustration represents this sideboard.

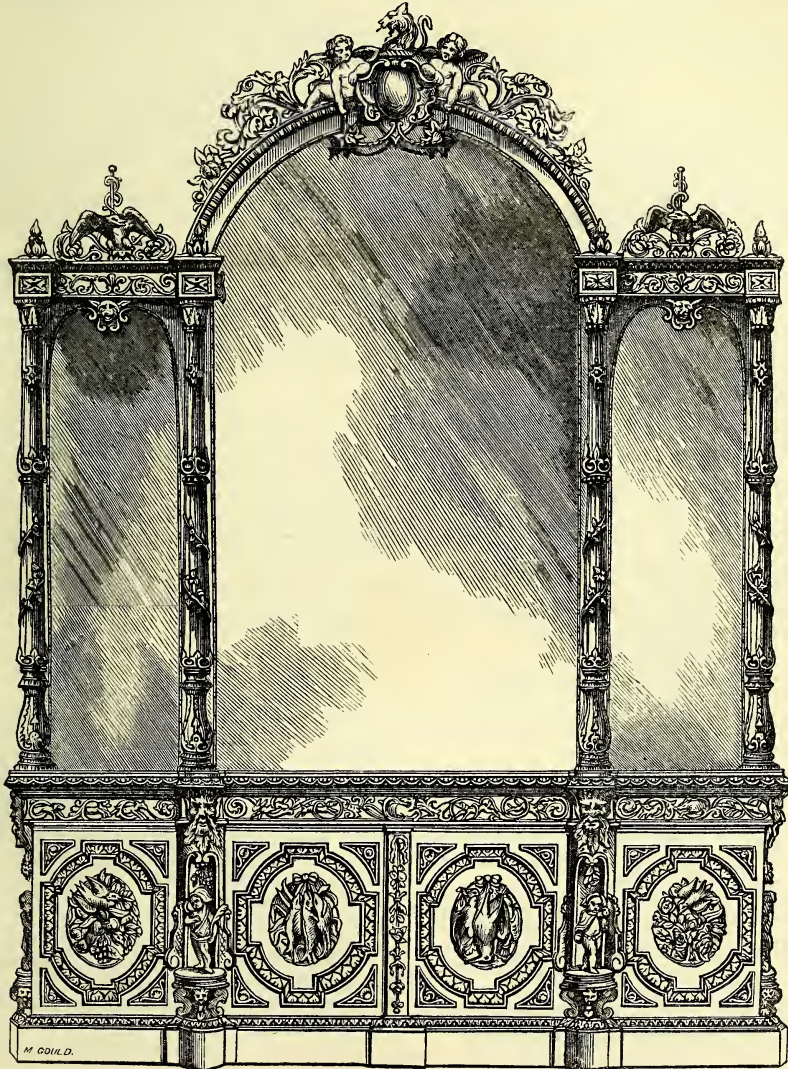

Trollope's Carved and Ornamental Sideboard.

Carved oak dining-room chair, to accord with the sideboard.

Suite of furniture for a bed-chamber, of novel forms, consisting of a bedstead, a wardrobe, toilette table and glass, and a wash-stand of satinwood, banded with tulipwood. The panels of marquetry, each of the inlaid woods being (as in the ancient marquetry) of its natural colour, and not artificially dyed according to the modern practice.

Carved and gilt drawing-room chair, in Italian style, covered in Spitalfields silk.

163 MOULIN, —, Inventor.

Model of a pulpit.

164 MORANT, GEORGE J., 91 New Bond Street—
Designer and Manufacturer.

Specimen of decoration, exhibiting the pictorial and plastic arts.

Circular table, supported by swans, designed from a suggestion of the Duchess of Sutherland. This table and the following are represented in the Plate 34.

Smaller table, supported by storks, in enamel of white and gold, the top of painted glass.

Console table and glass of Italian design, inlaid with mosaic, to imitate the pietredure of Florence.

Small cheval screen, with a painting of flowers. Encoignure, consisting of shelves, supported by gilt dolphins.

Ornamental frame, made for Her Majesty, designed for the engraving of the portrait of His Royal Highness the Prince of Wales.

State inkstand of or-molu, inlaid with lapis lazuli and gems.

Cabinet of tulip-wood, inlaid, and enriched with mosaic. Carpet, of Glasgow manufacture.

165 NUNN & SONS, 19 *Great James Street, Bedford Row*
—Designers.

Chess table, made of Italian walnut-wood, with bas-reliefs in electrotype silver. Chessmen, carved in ivory.

165A CUNNING, WILLIAM, *Edinburgh*—Manufacturer.

Improved iron rocking-chair, for the drawing-room, in gold, and covered with French brocatel (from Whytock's, Edinburgh). In this chair the spine and back are supported, and the head and neck rest in a natural position. Exhibited as a useful invention for invalids and others.

Models of bedsteads, one in brass lacquered, the other in iron, japanned in imitation oak, and in the French style.

166 BANTING, WILLIAM & THOMAS, 27 *St. James's Street*
—Designers and Manufacturers.

Circular marquetric table, with likenesses of the Royal Family of England, painted in china, inlaid in the border of the top. The stand inlaid with marquetric, and carved, part gilt, and the whole mounted with or-molu ornaments.

Sideboard, made from oak grown in Windsor forest, on four carved truss supports, with silvered plate glass back, above, in carved frame.

Satinwood china cabinet, inlaid with marquetric, and brass mountings.

Secretaire cabinet of kingswood, with English china inlaid, and or-molu ornaments.

Oval table of Amboyna wood, with a marquetric border of sprays of jessamine, and brass mountings.

168 FOX, THOMAS, 93 *Bishopsgate Street Within*—
Manufacturer.

Bedstead of walnut tree, gilt, with lofty canopy and drapery of blue silk.

169 DURLEY, THOMAS, & Co., 66 & 67 *Oxford Street*—
Manufacturers.

Canopy bedstead of walnut-tree, in the Elizabethan style, with furniture of brocatelle, of English manufacture, and bedding.

170 SNELL & Co., 27 *Albemarle Street*—Manufacturers.

Chimney glass, the frame carved in walnut-tree.

Walnut-tree cabinet, for a library, arranged for the reception and division of papers.

Sideboard, with glass, and an oval cistern: the designs and models for the sculpture by Baron Marochetti.

Satin-wood wardrobe, with a glass enclosing the robe press in centre.

Oval table, with marquetric border, composed of natural woods, without staining. Library table. Carved fire-screen. Tea-poy, with marquetric and metal mountings. Work-table, with or-molu and china mountings. Small centre table of speckled ebony, with the same. Library sofa and couch, in morocco. Various patterns of chairs.

171 WEBB, JOHN, 8 *Old Bond Street*—Manufacturer.

Rock crystal vase and plateau, of the 16th century, with ornamental mountings of the present period, enamelled on gold by Morel.

Pair of candelabra, of sculptured wood, gilt, with or-molu branches carrying 72 lights. One of these candelabra is represented in the accompanying Plate (41).

Elbow and single cabriole chairs, carved in walnut-tree, and finished in silk.

Chess table, in the Gothic style, carved in walnut-tree, inlaid with Minton and Co.'s tiles.

Stand for old inlaid top, carved in walnut-tree in the renaissance style.

172 BRAUN & Co., *Old Fish Street Hill*—Manufacturers.
Pedestal glass ornament.

173 SANDEMAN, GEORGE, 9 *Greenside Street, Edinburgh*
—Designer and Manufacturer.

The Holyrood seat. Design of an ottoman with rests, ornamented all round with thistle foliage, boldly carved in dark oak.

174 SMEE, WILLIAM, & SON, 6 *Finsbury Pavement*—
Designers and Manufacturers.

Mahogany canopy bedstead, in the Tudor style, with hangings of crimson silk, of Spitalfields' manufacture.

Maple wood bedstead, with hangings of blue silk. Cabinet in the Louis Quatorze style, of walnut, king and tulip wood, inlaid with marquetric, and mounted with or-molu, chased and gilt.

Cabinet of walnut wood, with veined marble top, and marquetric panel, surmounted by a glass, in a carved walnut-wood frame.

Set of St. Domingo mahogany extending dining-tables, upon carved standard supports, with the patent screw movement, by Hawkins, for opening and closing tables.

175 WATSON, G., 42 *Spring Street, Paddington*—
Designer and Manufacturer.

Octagon marquetric table, with ebony moulding; royal arms in centre, surrounded by ribbons, with trophies of arms and bouquets of flowers; border of the four seasons in scroll and flowers; and four sections in scroll, birds, flowers, and butterflies, alternately.

176 TOMASINI, D., 234 *Tottenham Court Road*—
Manufacturer.

Chair, with rich figured satin.

177 WERTHEIMIER, SAMSON, 35 *Greek Street, Soho Square*—
Manufacturer.

Jewel-casket wrought into shape, pierced, richly engraved, or-molu mountings, malachite and different stone settings, finished inside with silk velvet, mounted on a gold carved stand, in the cinque-cento style. This casket and stand are represented in the cut on the next page.

Jewel-casket, with plateau, engraved in the cinque-cento style, with china inlayings.

Louis XIV. work-box, chased, pierced, engraved, gilt in or-molu, mounted with ornaments and porphyry.

Chased and gilt metal workbox, lined with velvet, pierced, in the Louis XVI. style.

Two candelabra for lights, with chased ornaments in or-molu, of the period of Louis Quatorze, one in metal, the other with china mountings.

Or-molu inkstand with pen tray, and China plaques, in the cinque-cento style.

Or-molu inkstand with pen tray, in the French style, with China plaques.

Embossed, pierced, and engraved inkstand, in the Queen Elizabeth style, mounted with malachite; and two China bottles.

Inkstand, in the style of Cellini, mounted with malachite, highly chased and richly gilt in or-molu.

Chased and gilt work-box, in the style of Louis XIV., pierced and lined. Paper knife, ornamented, chased and gilt.

Bell and match-box, richly engraved and gilt, with stone settings, in the cinque-cento style.

Bell, the Queen Elizabeth, chased, and set with different stones.



41. CANDELABRUM. MR. WEBB.



42. EXPANDING PLATEAU. MESSRS. JOHNSON AND JEANES.

Taper or chamber candlestick, in the cinque-cento style, gilt and engraved, set with different stones.

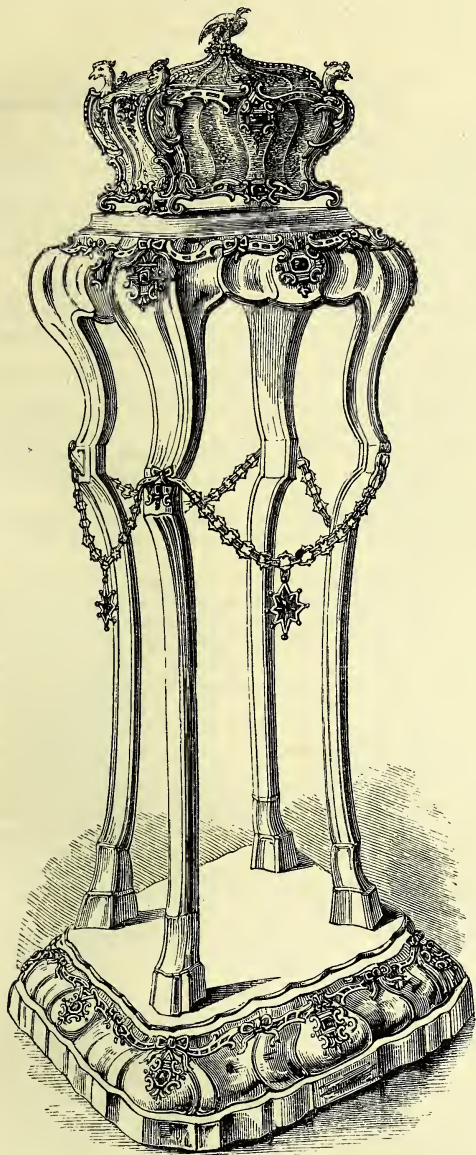

Wertheimer's Carved and Engraved Jewel-casket and Stand.

178 TOMS & LUSCOMBE, 103 *New Bond Street*—
Manufacturers.

A pair of pedestals in buhl and or-molu, and a pair of tulip-wood stands and cabinets ornamented with china and or-molu.

179 CLARK, SAMUEL B., 14 *Dean Street, Soho*—Designer
and Manufacturer.

Centre table of ebony, rosewood, and buhl, with richly-chased brown or-molu mountings.

Work-table of English walnut, on carved standards, with requisite fittings.

Bracket-table, specimen of petrification from Italy, the figures supporting it of carton-pierre.

A hanging mirror, in an ornamented frame, the decorations consisting of birds, flowers, shells, &c. This mirror

is represented in the annexed cut, with the bracket-table below it.

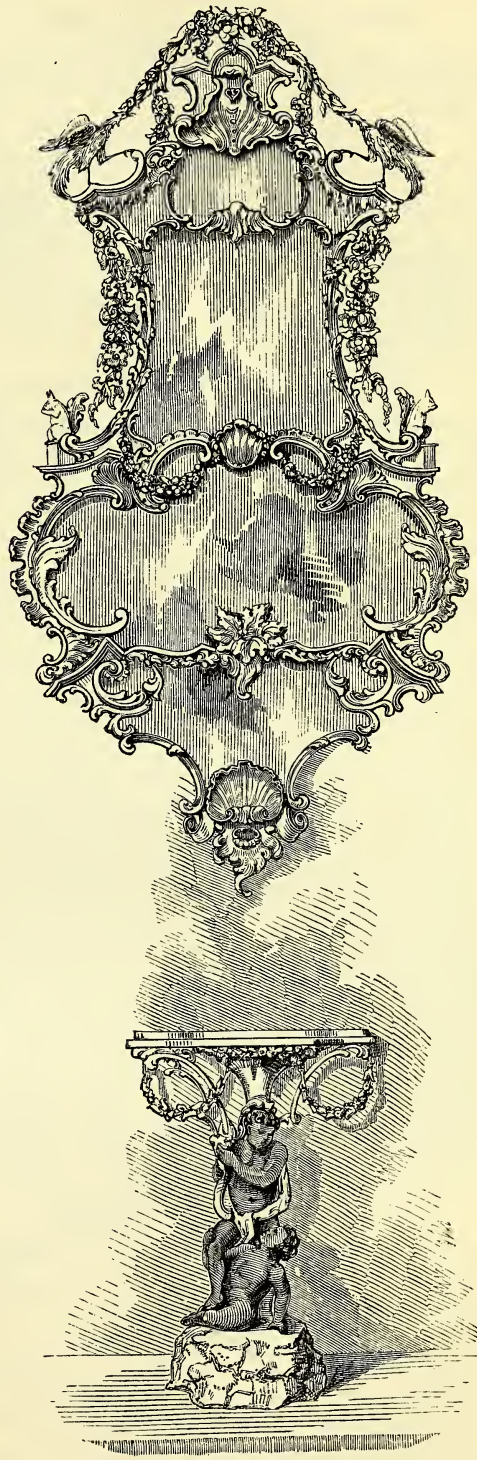

Clark's Hanging Mirror and Bracket Table.

180 BRUNSWICK, MYRTHIL, 26 *Newman Street, Oxford Street*—Designer and Manufacturer.

Marquetrie chiffonnière, inlaid in walnut, king, tulip, and other woods, and veneered inside with satin wood,

finished with brass and other ornaments, and various-coloured slate.

181 LE MERCIER, SARAH S. A., *Elm-tree House, Hammersmith*—Inventor.

Registered chair, invented in honour of H.R.H. Prince of Wales; the tapestry work is executed from a drawing by Mogford.

182 NICOLL, THOMAS, 39 *Great Tichfield Street*—Designer and Manufacturer.

A case with two pattern frames, for water-colour or crayon drawings. A cheval screen, carved in wood and gilt, which may be used as a frame to show water-colour or crayon drawings; the top centre ornament may be used as a candelabra for five lights, or a vase for flowers; the back, by withdrawing four bolts, will open and form a music-stand or a chess or coffee table. The subject of the picture is a pastel painting on vellum, "Peace and Plenty, results of Freedom and Industry."

183 LECAND, SAMUEL, 246 *Tottenham Court Road*—Designer and Manufacturer.

Genius of Commerce, console frame and table, in the style of Louis XIV., carved in American pine and limetree, and double gilt in mat and burnished gold; with silvered plate-glass. The top of table is of statuary marble. This mirror is represented in the Plate 61.

184 WILKINSON, W. & C., 14 *Ludgate Hill*—Designers and Manufacturers.

Carved four-post bedstead, of walnut-wood, French-polished, with a shield in the cornice for crest, carved and stuffed head-board, &c.; with a furniture of crimson cloth, trimmed with machine-embroidery in lieu of gimp, with satin medallion valance, edged with silk fringe; showing a new design, and a new adaptation of embroidery by machinery in the furniture. Spring mattress, on a new principle, capable of being used on both sides, instead of being made in a wood case; also an upper mattress and bolster. Down quilt in a silk case.

Wing wardrobe of a new design, veneered with fine walnut-wood on mahogany; with plate glass in centre door, and carved cornice; and fitted with hangings, closet, drawers, trays, &c.

Pedestal dressing-table, of selected mahogany, with a cheval glass in the centre part, and stuffed cushion for the feet in velvet, &c.

An ornamental secretaire, of tulip-wood, zebra-wood, and rose-wood, with fine brass ornaments; the desk lined with two leathers, inlaid.

A tulip-wood jardinière, banded with rosewood, and ornamented with brass.

A rosewood cheval screen fitted with plate-glass, ornamented with twisted work, fret-work, &c.

185 CARTER, M., 40 *Mary Street, Lower Hampstead Road*—Designer and Producer.

Altar-piece, painted in the early English style of church decoration.

186 GILLOW & Co., 176 *Oxford Street and Lancaster*—Designers and Manufacturers.

Mahogany sideboard, supported by carved eagles. Oval wine-cooler.

Walnut circular table; library table and chair; carved Wainstead sofa, with peculiar shifting, in morocco. English yew cabinet secretaire, lined with cedar.

Circular table of fine English porcelain, with painted landscapes and figures, groups and wreaths of flowers; on carved support: the porcelain by W. T. Copeland.

Mahogany picture frame, carved in Gothic style, and relieved with gold, &c., from a design by Mr. Pugin.

English oak, from a tree grown in Whittlebury Forest, Northamptonshire—a sample of English produce and manufacture.

[The botanical name of the tree yielding mahogany is *Swietenia mahogani*. Its principal habitats are the West Indies and Central America, in which countries the tree attains majestic proportions. Finely-marked logs of ma-

hogany sometimes realise almost incredible sums. A single log, 15 feet in length and 3 feet square, has been sold for 1,000*l.* The importations into Great Britain amount to about 25,000 tons annually.—R. E.]

187 JENNENS AND BETTRIDGE, 6 *Halkin Street West, Belgrave Square, and Birmingham*—Manufacturers and Draughtsmen.

"The Victoria Regia" papier maché cot, designed by J. Bell, sculptor, wrought in gold and colours of emblematical devices.

Registered pianoforte, in papier maché (seven-octave semi-cottage), the mechanism by Dimoline, of Bristol: the form and decoration in the Italian style. Papier maché music-stool and Canterbury, *en suite*.

"The multum in uno" papier maché loo table, combining chess, draughts, bagatelle tables, &c. Papier maché lady's work-table, of new form, ornamented and appropriately furnished. Provisionally registered.

"The lotus work-table," in papier maché, on an improved principle. Provisionally registered.

Papier maché tête-à-tête chaise-louge, ornamented with acanthus in white and gold.

"Le tournoi," "Jeu de la Reine," invented by Loysel. Set of papier maché toilet furniture, dove-coloured ground, relieved with gold.

Papier maché chairs: the Gothic illuminated, prie-dieu (the back and seat of painted velvet, and various other chairs.

The "day dreamer,"—an easy chair, designed by H. Fitz Cook, and manufactured in papier maché, by the exhibitors. The chair is decorated at the top with two winged thoughts—the one with bird-like pinions, and crowned with roses, representing happy and joyous dreams; the other with leathern bat-like wings—unpleasant and troublesome ones. Behind is displayed Hope, under the figure of the rising sun. The twisted supports of the back are ornamented with the poppy, hearts-ease, convolvulus and snow-drop, all emblematic of the subject. In front of the seat is a shell, containing the head of a cherub, and on either side of it, pleasant and troubled dreams are represented by figures. At the side is seen a figure of Puck, lying asleep in a labyrinth of foliage, and holding a branch of poppies in his hand. The style of the ornament is Italian. The accompanying Plate (30) represents this chair.

Bachelor's sideboard, on a new principle. An inkstand, with group of deer and hounds, designed by H. M'Carthy, sculptor.

Various papier maché articles, curiously ornamented; such as inkstands, reading-stands, sofa-tables, work-boxes and baskets, writing-desks, albums, portfolios, wine and tea trays, &c. The Pacha's tray, finely ornamented. Assortment of papier maché trays for hotels, &c. Papier maché "standish," "déjeuner tray," and bottle-stand. Pair of papier maché Pompeian flower-stands. Papier maché tea-tray, chest, and caddy. Clasp tea-caddy, on an improved principle, by H. M'Carthy.

A hemaroscope, on a new principle, invented by Dr. Keele.—Registered.

Pattern card of finger-plates, patent inlaid gems. Four tea-trays, exhibited for their cheapness, being of the second quality papier maché (or "pulp").

[There are two modes of manufacturing "papier maché" articles: the first is by pasting paper in sheets upon models, and the second by pressing in dies, the pulp of paper. The former produces the best quality, and the latter the least expensive and inferior kinds. The specimens above-named as "exhibited for their cheapness," are of the latter description, and the rest are of the former.

The exhibitors' patent process of inlaying mother-of-pearl, consists in pencilling the proposed design upon the pieces of pearl, in a vehicle adapted to resist acids, and then removing, by acids, the superfluous portions, leaving only those which are pencilled.





The principal advantages of this process consist in the superior effect producible by the pencil, and the greater facility of using it instead of the saw.]

188 ELOURE, WILLIAM WALTER, 12 Poland Street, Oxford Street—Manufacturer.

Various imitations of japan work. Cabinet doors and folding fire-screen, in imitation of India japan, ornamented with gold and inlaid with mother-of-pearl.

Table, painted in imitation of marble. Fancy table, imitation of Persian work. Chess-table, imitation ebony and ivory.

189 CLAY, HENRY, & Co., 17 & 18 King Street, Covent Garden—Designers.

Chiffonnière, in papier maché, ornamented in mother-of-pearl, gold, and colours; the panels, groups of fruits, and flowers.

Toilet-table and glass, in papier maché, new design and principle, with chair and footstool *en suite*. These are represented in the following engraving.

Table fire-screens with the centres in needlework. Multiformias, classical designs. Potpourri jars, pearl and gold. Tea-chest, ornamented in the Alhambra style. Lady's work-tray, gold and flowers. The Regency writing-desk, ornamented.



Clay, Henry, and Co.'s Papier Maché Toilet-table and Glass.

Paper tea-trays, from new models and designs.

A chess-table in papier maché, the centre of glass, enamelled with mother-of-pearl. This table is represented in the illustration on the next page.

190 DIXON, J., 18 Brownlow St., Holborn—Manufacturer.

Papier maché table, inlaid with pearl, and ornamented in burnished gold, &c. Original design.

Paper trays. Papier maché blotting-book, ink-stand, and card-basket, for drawing-room table.

190A HOWELL, JAMES, & Co., Regent Street—Manufacturers.

Tortoiseshell and buhl inkstand, with chased or-molu mountings, exhibited as a specimen of buhl and or-molu, by English workmen.

191 CHAPMAN, JOHN, 23 East Street, Lambeth—Sculptor.

Carved oak Gothic looking-glass frame, of the perpendicular style, possessing the flat arch. The figures in the niches are intended to represent the sense of sight; one supposed to be viewing herself in a mirror, the other reading in a book.

192 SOWERBY & CASTLE, 29 Albert Street, Camden New Town—Inventors.

Geometrical ottoman couch, constructed so as to as-

sume various forms of drawing-room seating. It may be placed against a straight wall or round a corner, to form a semicircle round the tea-table or fire-side, or to make a central circular ottoman. This couch in its various forms is represented in the following cut.

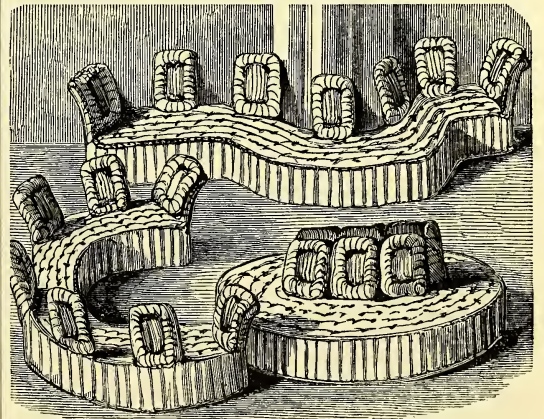

Sowerby and Castle's Geometrical Ottoman Couch.

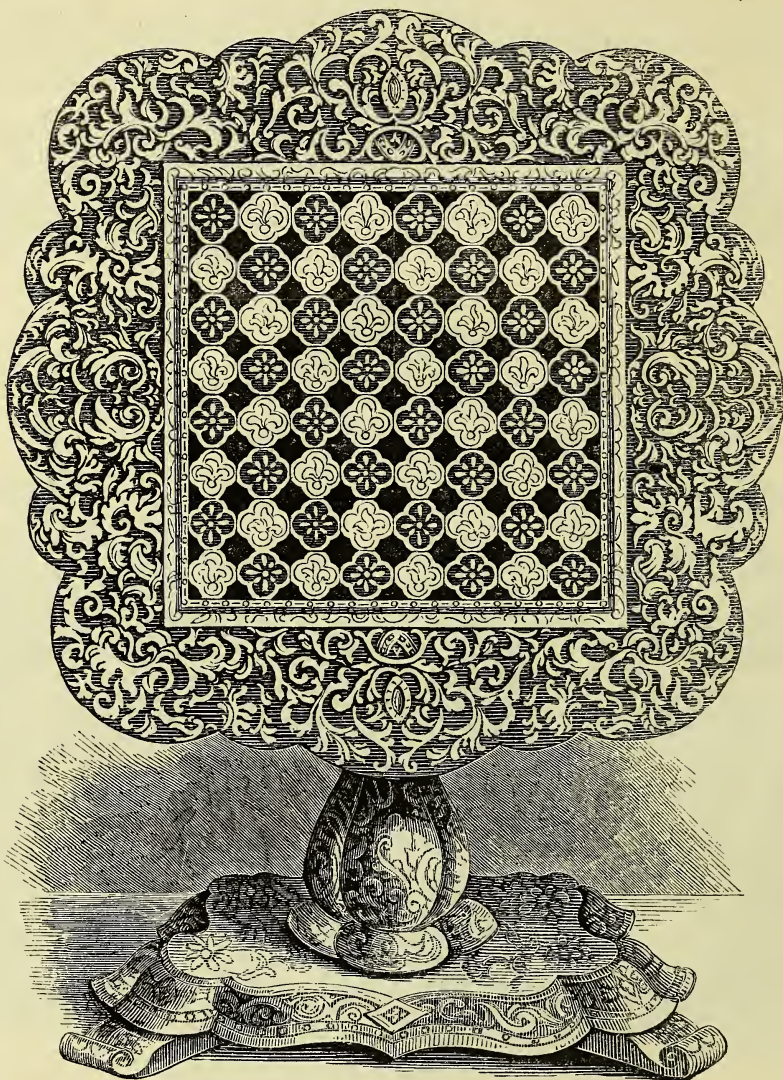

Clay, Henry, and Co.'s Papier Mâché Chess-table.

193 BOADELLA, JUAN, 72 *Charlotte Street, Fitzroy Square*
—Manufacturer.

Marquetrie table, applicable for a ladies' work-table, reading and writing-desk, artists' colour box and easel, with screen attached.

Buhl cabinet, containing 15 drawers, 14 of which lock at the same time.

194 WAKELING & SONS, 36 *Gerrard Street, Soho*—
Manufacturers.

Carved Arabian bedstead, in white and gold, with silk hangings.

195 ROGERS, WILLIAM GIBBS, 10 *Carlisle Street, Soho*—
Manufacturer.

Carved glass frame, executed for the late Wentworth Beaumont, Esq., and exhibited by permission of Mrs. Beaumont.

Two glass frames enriched with dead game, emblems of the chase, and groups of fruit and flowers, executed for Wentworth Beaumont, Esq.; exhibited by permission of Lord Lonsborough. Dead game.

196 PRATT, SAMUEL, *New Bond St.*—Manufacturer.

Carved sideboard, of English walnut, in the Elizabethan style; the marquetrie and fretwork cut by machinery.

Dining-table and dining-room chair to match. Patent Protean dining-table. Parquetrie, or inlaid work, for flooring.

Panelling, &c., manufactured in various designs and colours, by machinery. Ornamental Holland window-blind.

Saloon commode of English buhl, inlaid with tortoise-shell and colours, with or-molu mounts. Oval buhl table, *en suite*. Gothic altar-chair, carved by machinery.

197 HANSON, SAMUEL, & SONS, 16 *John Street, Oxford Street*—Manufacturers.

Ornamental walnut-wood cabinet, with glazed doors, for the reception and display of china, bronzes, or articles of vertu, surmounted with a carved glazed frame, in which are introduced various representations of birds, such as the egret, bittern, blackbird, woodpecker, jay, hawk, magpie, cuckoo, and sundry small English birds, variously arranged on an oak and a chesnut tree, &c.

Oval carved frame for a mirror, and sundry specimens of carving and furniture.

198 DONNE, GEORGE JOHN, 155 *Leadenhall Street*—
Manufacturer.

Looking-glass; plate-glass, manufactured at South Shields.

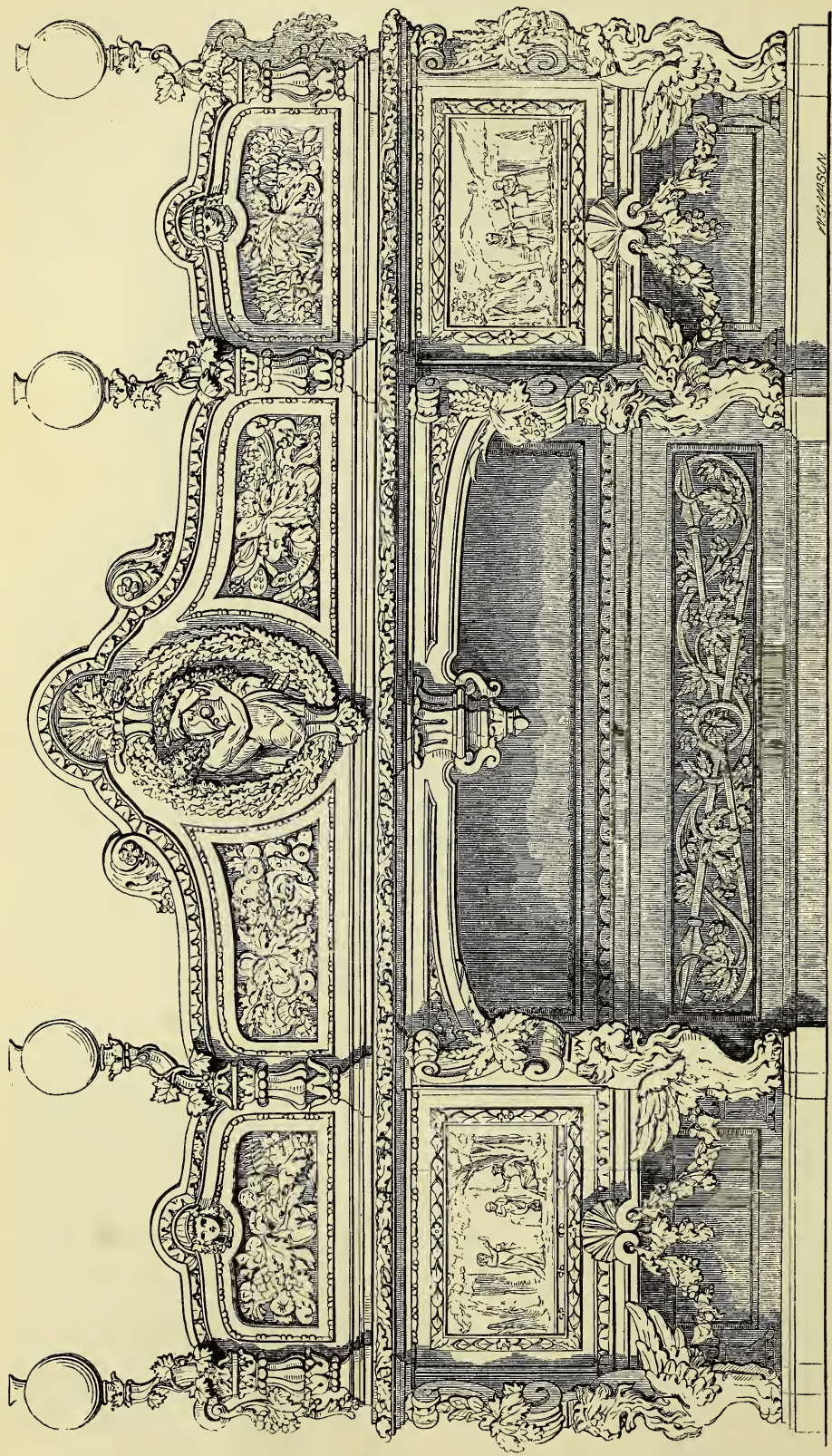

CARVED WALNUT-WOOD SIDEBOARD, WITH BRONZE ENRICHMENTS. POOLE AND MAGGILLIVRAY.

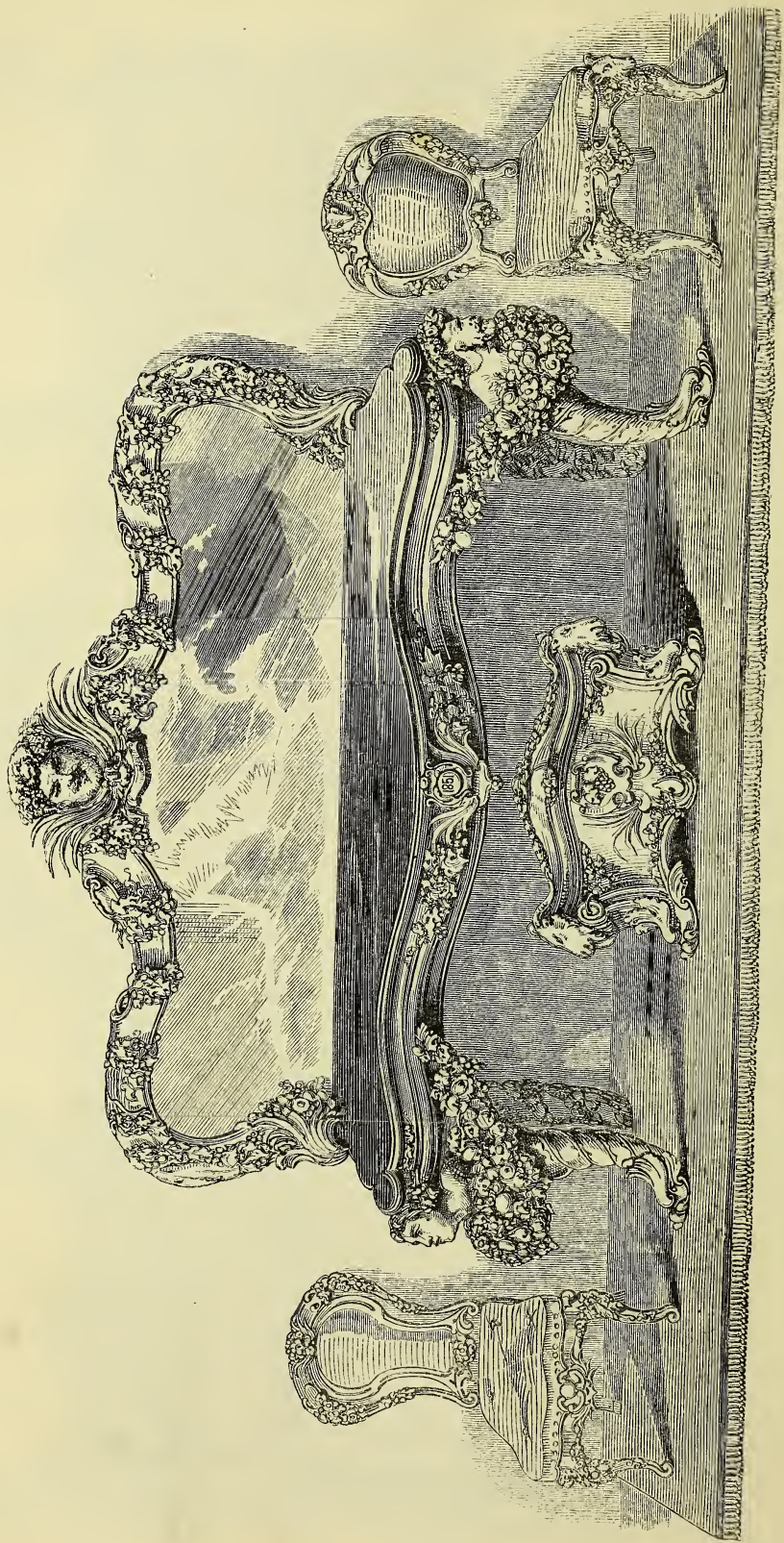

CARVED SIDEBOARD, OF ENGLISH WALNUT, AND CHAIRS OF UNIQUE DESIGN. W., J. R., AND E. HUNTER.

Specimen of attaran (or the finest quality of Moulmein teak timber), for railway carriages, ship and house building, and all purposes where perfectly straight timber is required.

[The teak tree (*Tectona grandis*) yields a timber in many respects remarkable and peculiar. It requires little time to season, and when worked up does not shrink like ordinary wood. Ships of teak have been known to last 100 years, owing to the almost indestructible nature of the timber. The Moulmein, or Maulmain, teak is largely imported into England, and is also extensively employed in ship-building in the East Indies. It is lighter and of more open grain than the teak from Malabar. Its application to railway carriages is becoming extensive, since it is found that the common timber of which they are constructed shrinks greatly, in consequence of the constant passage of the vehicle through the air in rapid motion.—R. E.]

199 **PONSONBY, THOMAS**, *Regent Circus, Piccadilly*—
Designer and Manufacturer.

Large chimney-glass, with carved and gilt frame. Large antique girandole, carved and gilt, with branches. Altar triptich Gothic, elaborately carved, and doors and panels emblazoned and illuminated. Sundry patterns of pierced and engraved picture-frames.

200 **STOCKEN, CHARLES**, *53 Regent Street*—
Manufacturer.

Coromandel wood and brass-bound dressing-cases, with silver mountings and chased edges on an improved principle, with expanding sides and drawer. Ladies' work-box, stationery-case, and writing-desk combined, with expanding sides, and gold fittings.

Ebony envelope-case and blotting-book *en suite*, ornamented with imitation iron-work, in rich metal; gilt mountings: style, 13th century. Walnut-tree wood envelope-case and blotting-book *en suite*, enriched with metal gilt mountings; design, ornamental scroll-work. The same in morocco with raised borders. Papier maché stationery-case and blotting-book *en suite*, inlaid with gems in imitation of diamonds, rubies, pearls, &c.

201 **GOODISON, JOHN**, *14 Cullum Street, Fenchurch Street*
—Producer.

Specimens of various decorations.

202 **HUNTER, W., J. R., & E.**, *30 Moorgate Street*—
Manufacturers.

Sideboard of fine English walnut-tree, supported on two cornucopias and dolphins' heads, which are carved with fruit, flowers, and figures representing Youth and Old Age. In the centre of the back is the head of Bacchus, surmounted with the palm. The vine, hop, and oak flow in clusters, with the hound and wild boar on each side. A marble slab, from Galway, forms the table part; and there is a cellaret below, unique in design and execution, with two chairs to correspond. This sideboard is represented in the accompanying Plate 29.

203 **LEVIEN, JOHAN MARTIN**, *10 Davies Street, Grosvenor Square*—Designer and Manufacturer.

Carved sideboard of New Zealand wood, the back representing nymphs and satyrs, surrounded by foliage; at the ends are medallion portraits of Queen Victoria and Prince Albert.

Escritoire of satin-wood in the Louis XIV. style, inlaid with tulip-wood, and ornamented. Jewel-case of tulip and king-wood, ornamented with or-molu, and inlaid with Sèvres china. Commode of satin-wood, in the Louis XIV. style, inlaid with tulip-wood, designed by Rosberg.

204 **POOLE & MACGILLIVRAY**, *25 Prince's Street, Cavendish Square*—Designers and Manufacturers.

Sideboard in walnut-tree, with carved and bronze enrichments; the pedestals supported by chimæra trusses.

Subject of the alto-relievo bronze panel: on the right, "Baucis and Philemon;" on the left, "The judgment of Midas." This sideboard is represented in the accompanying Plate 64.

205 **HERRING, ROBERT WILLIAM, & SONS**,
109 Fleet Street—Decorators.

Cheval dressing-glass, carved in wood in the style of Louis XIV., and gilded to imitate the Roman or-molu.

Writing table, mounted with or-molu enrichments. Upon the top, in rich marquetric, is represented a garden scene with figures, after the manner of Lancret.

Centre table, made of fine walnut-wood, inlaid with metals, ivory, and pearl. As a border, divided by trophies inlaid in white metal and pearl, are the six subjects, designed by Flaxman, "The opening of Pandora's box," inlaid in brass and etched.

One of the objects in view is to exhibit an application of the products of high art to the embellishment of ordinary furniture.

206 **CALDECOTT, MESSRS.**, *53 & 54 Great Russell Street, Bloomsbury*—Designers and Manufacturers.

Sideboard made of English timber oak, in the renaissance style.

Octagon table, showing specimens of fine Amboyna wood, and inlaying.

207 **RICHARDSON, CHARLES JAMES**, *2 Keppel Street, Russell Square*—Architect.

Carved oak frame and picture cornice, intended for the new dining-room, East Sutton Place, Kent. (Mr. Learmouth, maker.) Carved oak frame, made by the drill (on Irving's Patent). Examples of coloured lithographic printing (from the presses of Mr. Day and Mr. McLean). Design of a chimney-piece, ornamented with Parian statuettes. Design for the decoration of a panel in the Persian style. Designs for furniture, ironwork, decorations, paper-hangings, &c., in the Elizabethan style. Carved oak table and stool, the principal blocking out done by the drill, on Irving's Patent, Mr. Learmouth, maker. Mounted horn, the mounting executed by Mr. Jackard, student of the School of Design, Somerset House.

208 **BAILES, HENRY**, *29 Tottenham Street*—Designer and Manufacturer.

Inlaid marquetric door, suitable for a mansion, or clubhouse, with bold carved frame and architrave, complete. Pair of therns inlaid with marquetric, and mounted with or-molu.

Fruit and flower pieces, with ornamental border in marquetric.

209 **HARDING & SON**, *65 Fore Street, Cripplegate*—
Manufacturers.

Walnut table. The top and sides are inlaid with marquetric, of French manufacture.

210 **WOOLLAMS, WILLIAM, & Co.**, *110 High Street, Marylebone*—Manufacturers.

Decorative paper hangings in various styles. Alhambra, Pompeian, arabesque pilasters, and raised gold mouldings; a screen of various new specimens of paper hangings. One of these paper hangings in arabesque style is represented in the Plate 38. (*East Gallery.*)

211 **MINTER, GEORGE**, *51 Frith Street, Soho*—
Inventor and Manufacturer.

Invalid couch, or bed, being a great improvement in the arrangement and construction of this article. A person can be placed on it in any required position, and can be raised from an horizontal to a sitting position, without being disturbed by the necessity of using their own exertions, or by those of an attendant. The simplicity of the invention making it more effective and easy in the transit from one position to another, (which can be accomplished by a child,) than any of the various articles of the kind previously in use; one of which is generally known as Dr. Earl's spinal or fracture couch. The advantage of the present invention consists in the

application of three Archimedean or endless screws, one of which, by turning the top handle at the end of the couch, raises the back to any desired elevation; and by

turning the handle at the side, the knee-joint is raised, and the couch then assumes the position shown in the annexed cut.

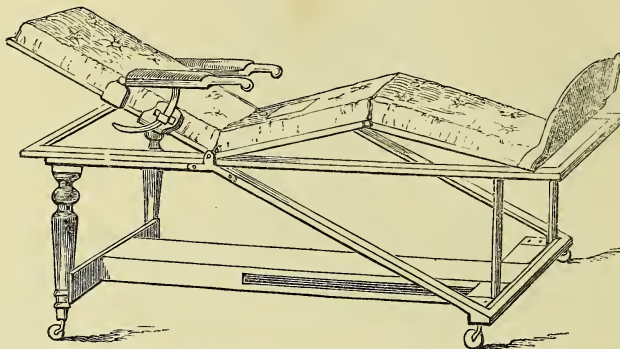

Minter's Invalid Couch. Reclining position.

Again, by turning the bottom handle at the head of the couch, the whole of the top frame is acted upon, and the couch assumes the position shown in the following cut. These positions can be varied, more or less, as best

suits the invalid. The various inclinations during the transit from one position to another, can be made available, as the couch remains fixed at all angles, except when turning the handles attached to the screws.

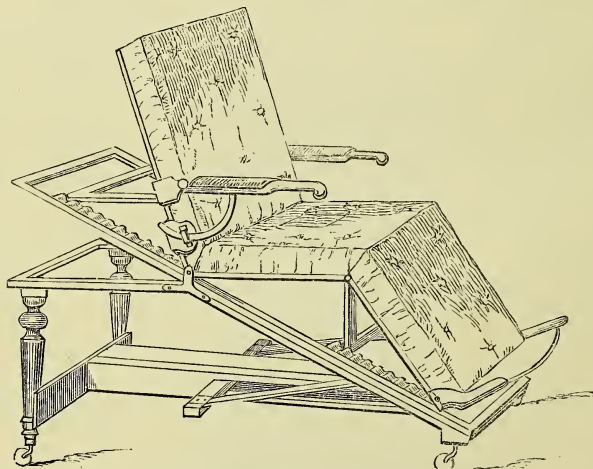

Minter's Invalid Couch. Sitting position.

211A WHITCOMBE, A., *Cheltenham*—Designer and Manufacturer.

Portrait frames, carved and gilt.
Toilet-glass, in carved and gilt frame.

212 BELL, DAWSON, 10 *Ann Street, Belfast, Ireland*—Manufacturer.

Carved devotional chair, of bog oak, a wood found in the Irish peat-bogs, at a considerable depth, being the remains of the ancient forests; its dark colour is acquired by the action of the peat. In the carving are introduced the figures of Hope and Plenty, with a chasing of shamrocks, scrolls of oak leaves, and the harp of Brien Boroihme, an ancient king of Ireland; the strings are of native silver wire. The upper arm of the harp is ornamented with two crystals, termed "Irish diamonds." Over the harp is a shield, with the arms of the O'Briens; and surmounting all, the ancient Irish crown. An Irish wolf-dog, couchant (species now extinct), is at the side of the harp. The device in needlework, on the panel, was designed by the exhibitor, and executed in Belfast, being a group of national emblems; a minstrel and his harp, an oak, wolf-dog, round tower, castle in ruins, brazen vase, antique trumpets, shamrocks, and oak leaves. The covering of the cushion is in keeping with the panel, representing the mether or drinking-cup, charter horn,

shields, swords, ancient royal crown, war pennon, bow, quiver and arrows, bronze reaping-hooks, all copied from drawings of existing relics.

213 ASPINWALL & SON, 70 *Grosvenor Street*—Inventors, Manufacturers, and Proprietors.

Registered card-table. Dining-room chair, with apparatus, by which various inclinations can be obtained.

214 CHAPLIN, THOMAS, *Rose Tun Street, Kilkenny, Ireland*—Manufacturer.

Ornamented circular oak table, on pillar, tripod, and claw, without clamps, retches, and thumb-screws; with top veneered in figures; outside border inlaid with oak-leaves and acorns; and solid moulding round the top.

215 CURRAN, J., & SONS, *Lisburn, Co. Antrim, Ireland*—Designers, Carvers, and Manufacturers.

Sculptured and perforated arm-chair, from the antique; with fruit and foliage from nature, but grotesque figures; of Irish black bog-oak, found in Moyntagh's Moss, Ballinderry, Antrim, Ireland, made by three poor working men, expressly for the Great Exhibition. It occupied the workmen during eight months, at unlimited hours; the covering of the seat and back are of crimson-silk velvet, manufactured by E. Jones, 3 St. Andrew-street, Dublin.

A piece of the wood in its seasoned, but unfinished state. Original pencil designs by the makers, who are self-taught.

217 VERRINDER, J., *Lincoln*—Inventor.
Sofa bedstead or couch.

218 BACON, WILLIAM, 65 *Wells Street, Oxford Street*—
Inventor and Manufacturer.
Folding spring mattress.

219 BUDGE, JOHN, *Wells, Somerset*—Manufacturer.
Model, in English oak, of a chair formerly the property of Abbot Whiting; now in the possession of the Bishop of Bath and Wells. Miniature model, in ivory, of the same chair, on a scale of $1\frac{1}{4}$ inch to a foot.

220 BRITTAN, W., *Butleigh, near Glastonbury*—Producer.
Carved chair and rustic flower basket.

221 COTTAM, E., 2 *Winsley Street*—Inventor and
Manufacturer.
Patent spring bedstead.

222 HARRISON'S WOOD CARVING COMPANY, *Ranelagh Road, Thames Bank, Pimlico*—Producer.
Cabinet, in carved oak. This cabinet is represented in the accompanying engraving. It is formed of British wood, coloured by being charred by heat.

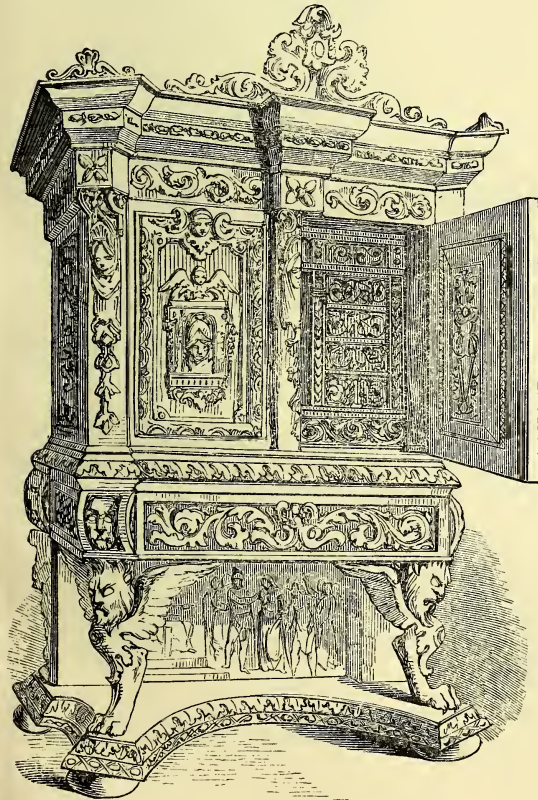

Harrison's Carved Oak Cabinet.

224 EVANS, FRANCIS, 18 *Albert Street, Deptford*—
Inventor.
Music stand, constructed of one piece of wood, which can be opened out with legs, desk, slide, &c.
Model of a chair constructed on the same principle.

225 CAWLEY, JOSEPH, 1 *Michael's Place, Brompton*—
Designer and Manufacturer.
A three-post bedstead in fine Spanish mahogany, the rod forms a part of the cornice.

228 NUNN, JOHN, 7 *Upper Vernon Street, Lloyd Square*—Designer.
Picture frame to answer the purpose of a portfolio, and to change the prints or drawings at pleasure.

229 PAGE, H. M., *Coventry Street*—Manufacturer.
Novel adaptation of a dressing-glass and dressing-case. Registered.

230 BILLAMORE, Mrs.—Inventor.
A newly-invented chair.

231 GARDNER, JOHN HENRY, 19 $\frac{1}{2}$ *Poppin's Court, Fleet Street*—Designer and Manufacturer.
Satin-wood toilet glass, in carved frame, supported by ornamented columns, on base containing jewel-drawers, &c., suspended by Cope and Austin's patent movements.
A mahogany table containing toilet glass, &c. The glass, on being raised, falls into any position required. Underneath are contained razors, brushes, &c.

232 WELLS, EDWARD, 310 *Regent Street*—Producer.
Landscape transparent blind, "a scene at Windsor Castle in 1850, the Queen, Prince Albert, and the royal children."

233 SANG, FREDERICK, 58 *Pall Mall*—Designer.
Specimens of interior decorations, or coloured architecture. Interior of the Royal Exchange; vestibules and grand staircase at the Conservative Club, St. James's Street; and of King James's Room at Hatfield House, Hertfordshire. Design for the decorations of a club-room. Interior of a coffee-room at the New Carlton Club, Pall Mall. Interior decorations for a banking hall. Interior of the new assembly hall at Bury. Design for the decoration of an exchange.

234 HOPKINS, HARRY, 13 *Westmoreland St., Marylebone*—
Manufacturer.
Table top, painted in imitation of marble. Panel and Stile, painted in imitation of woods, inlaid.

235 COOPER, W. M., *Derby*—Manufacturer.
Pulpit made by the exhibitor for a church at Holbeck, Leeds; the figures cut by John Philip, from a design by Mr. Geo. Gilbert Scott, of London.

236 WETHERELL, F. S., 13 *Shepherd Street, Oxford Street*—Designer and Manufacturer.
Carved oak Gothic cheval firescreen, for a drawing-room, enriched with vine foliage and animals of the chase. The glass panel screens the heat but affords the view of the fire.

237 HAWKINS, SAMUEL, 54 *Bishopsgate Street Without*—
Patentee and Manufacturer.
Model set of expanding dining-tables, to show the adaptation of the patentee's patent screw movement, by which one person can open and close any sized dining-table; by this application no fastenings are required for the tops or flaps, or extra legs in the centre of the table, the expander bearing the whole weight, and being equal to 4 tons in strength. This patent screw movement is shown in the cut on next page, fig. 1.

A, a solid iron screw, to work in B.
B, a screw cut on tube, to work in C.
C, a screw cut on tube with nuts inside, to work in D.
D, tube or case with nuts inside, to receive A, B, C.
E, Brackets, for D to rest and revolve.
F, crank handle by which the whole is put into motion, extending the dining-tables to any required distance.

Fig. 1.

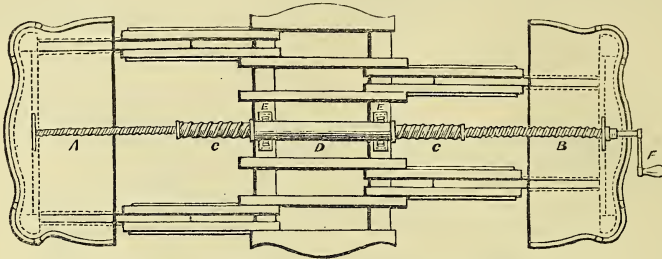

Hawkins's Patent Screw Movement for Dining-tables.

Model set of expanding round tables, to show the adaptation of the exhibitor's patent cog-wheel, with screw movement, for expanding and contracting circular dining-tables. This movement is shown in the adjoining cut, fig. 2.

1. Cog-wheel in centre.
2. Arms with racks.
3. Guide-wheels, to keep arms to their work.
4. Screw, which being put into motion with the
5. Crank handle, the frame extends each way equally. A passes under B to rack-irons, extending table to nearly double its original size. This part is shown separately in fig. 3.

Fig. 3.

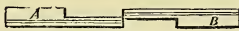
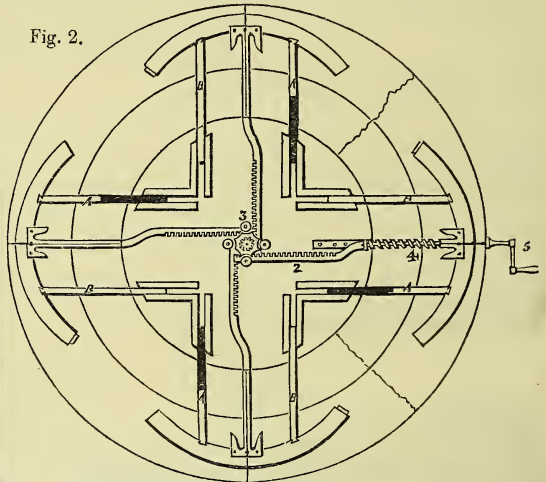

Fig. 2.



Hawkins's Patent Cog-wheel Movement for Dining-tables.

238 HOWARD, JOHN, & SON, 22 *Berners Street, Oxford Street*—Manufacturers and Designers.

A walnut-wood cabinet, ornamented with flowers drawn and modelled from specimens at Kew Botanic Gardens, by the designer, assisted by Mesdames Peachey and Strickland, wax floral artists; designed chiefly as an ornamental adjunct to the boudoir or drawing-room, to contain articles of vertu. The slab is of Magnus's patent mosaic, designed by Howard.

239 HANCOCK, NICH., 6 *Bartlet Court, Bow Street*—Inventor.

Invalid and drawing-room easy reclining chair, to obviate the necessity of using pillows to support an invalid when placed up in bed; it forms a stool, and also a handsome drawing-room easy chair for common use.

240 BOARD, CHARLES, 28 *Swindon Street, Gray's Inn Road*—Manufacturer.

Spring pillows made of spiral steel springs and whale-bone. Model of a quilt made of an article imported from Russia, and covered in crimson silk. Various samples of white goose feathers.

241 ISAACS & CAMPBELL, 21 *St. James Street*—Inventors and Manufacturers.

Patent portable barrack, college, camp, and cabin furniture, containing a chest of drawers, a wash-hand stand, dressing-table and glass, iron bedstead, with curtains and bedding, reclining chair, towel-horse, writing and dressing-case, and having sufficient room in the drawers to contain a complete military outfit, the cases at same time forming a wardrobe.

242 JACKSON, GEO., 4 *Russell Meus, Fitzroy Square*—Manufacturer.

Walnut-tree carved cabriole settee, representing three backs of chairs, covered.

246 KENDALL, CHARLES HOLLAND, 24 *Mark Lane*—Inventor and Improver.

Decanting machine, corking machine, wine-finishing wisp, and champagne capsule.

247 EDWARDS, SAMUEL, 13 *Cannon Street Road*—Manufacturer.

Four-foot octagon revolving library table, containing 14,000 pieces of English and foreign woods. This table occupied ten months in the process of manufacture.

251 LATHAM & DIGHTON, 1 *Bateman's Buildings, Soho Square*—Designers and Manufacturers.

Metal gilt vase and cover for flowers, ornamented with amethysts, garnets, turquoise, &c.

252 MOXON, CHARLES, 33 *High Street, Marylebone*—Decorator.

Decorations for a drawing room, consisting of imitations of inlaid marbles, panels, &c. Chimney piece and glass frame, by John Thomas. Panels of imitation of inlaid woods, showing the mode of application for general decorative purposes. Imitations of marbles, for decorations.

253 MARCHANT, WILLIAM—Manufacturer.

Lady's work-table, consisting of a chess-table, with drawers, &c.

254 MARTIN, WILLIAM, 6 *Rutland Street, Hampstead Road*—Inventor.

Registered ornamental flower-pot cases.

255 GREVERIE, A. S., *Harrington Cottage, Brompton Park Lane, Brompton*—Manufacturer.

Oval table, hexagonal stools, vases, round stand, and basket; ornamented with flowers, made of mixed wood, holly, oak, cedar, elm, &c.

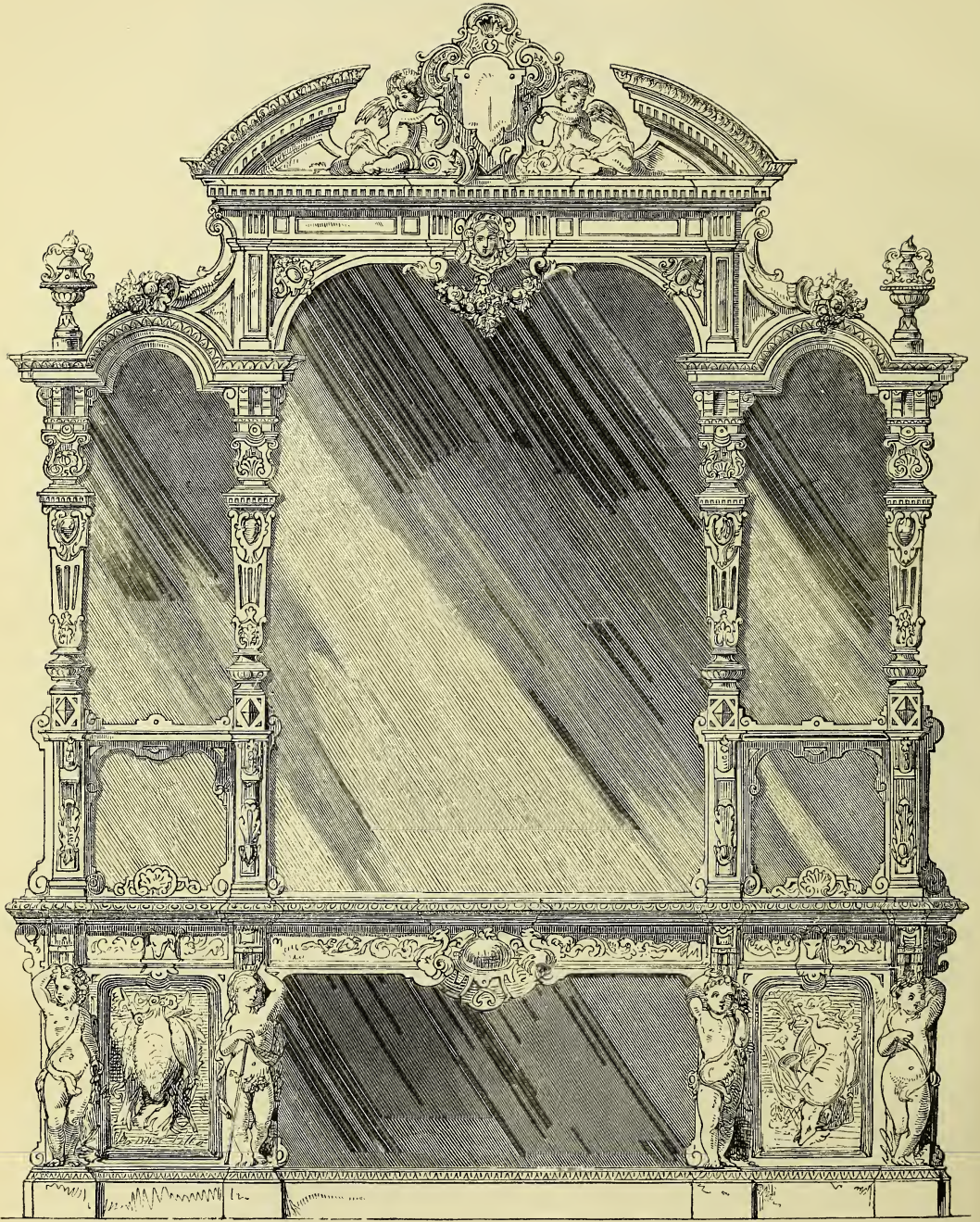

256 MILES, HENRY, 16 *Seabright Place, Hackney Road*—
Inventor and Manufacturer.

Rosewood loo-table, inlaid on top and bottom block, containing a secret cash-box.

257 NORTH, D., 23 *Great Windmill Street, Haymarket*—
Designer and Manufacturer.

Rosewood oval tea caddy, with flowers carved in satin-wood, the interior fitted with small oval caddies in rose-wood, with carved flowers. Two satin-wood sugar-basins. Oval vase ebony inkstand, the interior fitted up with loose inside, and tray with ink bottles.

258 NUTCHEY, JAMES, 5 *West Street, Soho*—Designer
and Manufacturer.

Pair of candelabra, in ebony and ivory, supported on columns, polygon, and spirally turned. Flower-stand in English yew-tree.

259 NORTH, CHARLES, 1 *Queen's Head Court, Great Windmill Street*—Designer and Manufacturer.

Reading stand, capable of being placed in any required position. Bed-chair for invalids, in which they may recline in any position.

260 PINNELL, THOMAS DURSTON, 5 *Warren Street, Camden Town*—Manufacturer.

Gilt zinc frame, with trellis-work border, and silk velvet lining.

261 JACKSON & GRAHAM, 37 & 38 *Oxford Street*—
Manufacturers.

Sideboard of English oak in the renaissance style, the pilasters formed by figures representing hunting and fishing, summer and autumn. This sideboard is represented in the accompanying Plate 118.

Dwarf bookcases in walnut-tree.

Dining-room or library chair, of English oak, in the renaissance style.

Carved and gilt drawing-room chair. Library sofa. Carved and gilt cheval screen.

262A REYNOLDS, JOHN, 57 *New Compton Street, Soho*—
Manufacturer.

Wire table for flowers.

263 ROBINSON, C., 6 and 7 *Greenland Place, Gray's Inn Road*—Inventor and Manufacturer.

Portable metal bedstead, which will form also a half tester bedstead, chair-couch, and ottoman; the ottoman-case contains every requisite.

264 ROGERS & DEAR, 23 and 24 *St. George's Place, Hyde Park Corner*—Manufacturers.

Renaissance bedstead in walnut-tree, carved, with foot and head-board in relief, stuffed panels, deep-shaped moulded cornice, canopy tester, English tapestry hangings, complete, and trimmings.

Ottoman coal sarcophagus, answering the purpose of an ottoman and coal receptacle; constructed of walnut-tree, French polished; the seat is stuffed and lined with green Utrecht velvet; the interior is furnished with a hopper, lined with zinc, in order that the superincumbent coals may be made to supply the place of those removed by a shovel; the top is hung on hinges, and a flap in the plinth of the sarcophagus lets down in front, and is received by a spring fastening. Designed by Francis Whishaw, Esq.

Plain French-shaped mahogany bedstead, to exhibit an apparatus for making one get up.

265 ARCHER, E. T., 451 *Oxford Street*—Manufacturer.
Specimens of paper decorations.

266 HINDLEY, C., & SONS, 134 *Oxford Street*—
Proprietors.

Sideboard, manufactured of British red oak in the Tudor style, with rich mouldings and carvings, the back of silvered plate glass.

Chiffonière, of English walnut-tree, carved, the top of fine sienna marble, the back of silvered plate glass.

Davenport writing-table, of Albuera-wood, on pedestal, with carved panels and columns. Occasional table, of maple, on ornamental standards. Chess-table, of rare Chinese woods, inlaid by the natives, on quadrangular stand. Portfolio-table, of American birch, carved, with folding top to rise and slide. Chess-table, inlaid top on walnut-tree, quadrangular stand. Octagon pedestal bookcase, of Baltic oak. Lady's writing-table, of English walnut-tree. Pedestal Davenport writing-desk, of New Zealand Totara wood.

Ornamental table for flowers, of American birch.

Gothic library chair, of British red oak. Carved cipher chair, of English sycamore wood. Carved arm chair, of American birch. Lounging chair, and easy chair.

Cabinet for coins, of Kyabooka wood, carved and gilded, fitted with numerous trays.

Ornamental toilet glass, of English walnut-tree, in the Elizabethan style.

267 SIMPSON, GEORGE, 12 *Eldon Street, Finsbury*—
Designer and Manufacturer.

Improved ornamental library table, registered pattern. The drawers on either side, by simply moving a rod or bolt, with springs attached, can be easily fastened or unfastened.

270 SIMPSON, WILLIAM BUTLER, 456 *West Strand*—
Manufacturer and Designer.

Paper-hanging decorations, executed in distemper colours, washable with soap and water. Imitation of the decorations of Pompeii, and simple ornamental panelling, with pilasters. Others, with the ground colours in washable distemper and the ornament in encaustic colours: Italian, Arabesque, and Gothic; also, gold ornaments on flock ground in panels.

These articles are designed for the decoration of the walls, ceilings, and panellings of rooms, in a superior style, and at a moderate cost.

Their novelty and great advantage arises from the colours, which are used in distemper, being hardened and rendered washable by an after process; so that while the colours retain all the brightness of distemper colouring, they are as permanent as oil colours, and will bear constant cleaning with soap and water. This process is patented.

271 SCROXTON, J. H., 137 *Bishopsgate Street*—
Manufacturer.

Show goods, used by tea dealers and grocers, for decorating shops. Vases in tin, ornamented and japanned. Octagon stands, inlaid with pearl. Bowls and brass beads. German silver tea-scoop.

273 SQUIRE, CHARLES, 20 *Old Fish Street*—Inventor and
Manufacturer.

Apparatus for baking wood, for the purpose of ve-neering, and for boiling and distilling water.

Looking-glass, with ball and socket movement, convenient for taking to pieces and packing in small compass; the movement prevents the quicksilver from being damaged.

Composition and wood picture frames, gilt, silvered, and coloured.

275 THOMAS, WILLIAM, 29 *Berners Street, Oxford Street*—Designer and Manufacturer.

Specimen of figure-carving, in oak, with a design for the door of a palace of justice.

Frames (in composition ornaments) manufactured by the exhibitor for Her Majesty, and the Royal collection of enamels and gallery pictures; applicable to the requirements of light, &c.; with a new method of ornamenting frames for low relief.

276 THOMAS, J., 9 Old Church Street, Paddington, and New Palace, Westminster—Architect and Sculptor. Glass frame, with foliage, &c.

Chimney-piece, containing medallion of Chaucer, with alto and bas reliefs; and figures representing the virtues of Dorigene and Griselda; the imitation of inlaid marbles and decorations by Charles Moxon. Chimney-piece, containing medallion of Spenser; with alto and bas relief figures representing the preservation of Una and the trials of Florinel. This chimney-piece is represented in the following cut.

Bas-relief, representing the horrors of war.



Thomas's Ornamental Chimney Piece.

279 WARD, JOHN (late GRIFFIN & WARD), 6 Leicester Square—Manufacturer.

Improved recumbent chair for invalids; a self-propelling chair, made portable for travelling, with vulcanized India-rubber wheels.

285 WALLER, FREDK., 49 Fleet Street—Manufacturer.

Commercial and diplomatic despatch writing-desk, in rosewood; the open paper-rack and folding slope desk being combined, so as to form a portable appendage to the writing-table. The annexed cut represents this writing-desk.

Small, rosewood, open desk for ladies, containing various sizes of note paper and envelopes.

287 JONES, WILLIAM, Dolgelly, Wales—Inventor and Manufacturer.

Portfolio table, turning on a pivot and lifting like a reading desk. Ebony tripod.

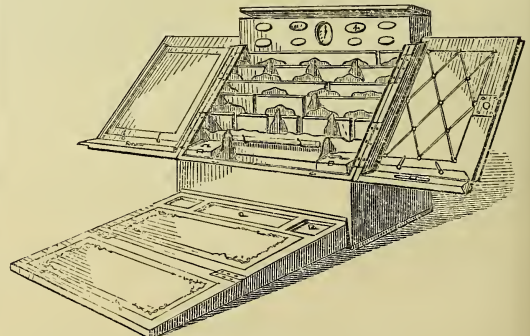

Waller's Commercial Writing-Desk.



288 WARREN, THOMAS, 371 *Oxford Street*—Inventor.

Patent reading-stand, carved in rosewood, and enriched with gold and or-molu ornaments, with stuffed foot-cushion in crimson Utrecht velvet, for holding a book in any position, sitting, standing, or reclining. The following cut represents this stand.

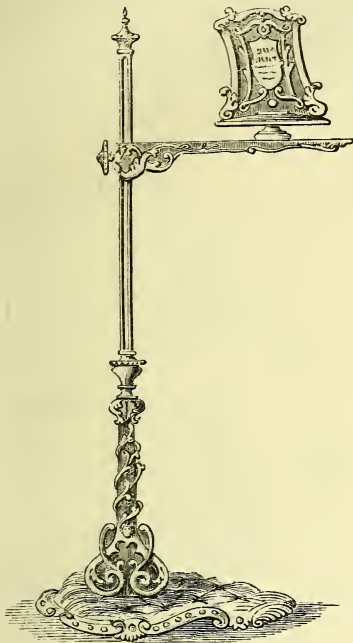

Warren's Patent Reading-Stand.

289 CREASER, MRS., 18 *Melton Street, Euston Square*—Inventor.

Ladies' writing-table, with drawers, on an entirely new principle.

291 COOPER, G., *Kingston, Surrey*—Producer.

A rustic chair.

292 MUMMERY, FREDERICK H., 5 *Railway Place, Holloway Road*—Manufacturer.

Pianoforte bedstead. Press bedstead in a pianoforte shape.

293 WILSON, JACOB & SONS, 18A *Wigmore Street, Cavendish Square*—Inventors and Manufacturers.

New oval centre table, with a revolving top; one side of walnut wood, the other of cloth as a card or writing table. Similar table, with a circular bagatelle-board attached.

New work-table, with a silk bag at each end; the top to revolve and form a table for two different uses. Similar table, with a chess-board attached. Library table of mahogany, of a new shape and construction.

300 SCOTT, CUTHBERTSON, & Co., 49 *Lower Belgrave Place, Pimlico*—Manufacturers.

Illuminated Gothic decorations of the period of Henry the VII., for dining rooms, libraries, and halls, &c. Floral decorations for walls of drawing-rooms, &c. Decoration with fleur-de-lis panels.

301 D'ALMAINE, WILLIAM FREDERICK, 8 *Percy Street, Bedford Square*—Designer and Manufacturer.

Decorative panel, in the style of Edward I.

303 ARTHUR, THOMAS, 3 *Sackville Street*—Producer.

Screen painted by hand in oil colours, with subjects from nature, suitable for a drawing-room, boudoir, &c.

Registered damask pattern of paper-hanging. Specimens of fine woods and marbles in graining. Decoration imitating inlaid marbles; suited for staircase or hall. It may be executed in paper or by hand.

304 ASCROFT, THOMAS, 35 *Queen's Road, Chelsea*—Designer and Proprietor.

Original design for paper-hangings, being a new combination of damask and chintz work.

305 BARRETT, JOSEPH, 246 *Bethnal Green Road*—Designer.

Drawings for paper hangings.

307 COOMER, J., 66 *Brand Street, Blandford Square*—Producer.

Painted table-top, in imitation of inlaid woods. Slab, in imitation of inlaid marbles.

308 GODDARD, JOHN, 7 *Bedford Place, Hampstead Road*—Designer.

Design for paper hangings, of British and exotic flowers; air plants of the torrid zone, in natural positions appended to a palm.

[The plants popularly called air-plants are known to botanists under the name of *orchids*. They form a distinct, and in many respects a most peculiar and anomalous natural family. The principal source of their solid tissues is the atmosphere, from which, in common with plants growing in the earth, they absorb carbonic acid, the decomposition of which furnishes their food. They are very commonly found in tropical forests, hanging down their curious roots and fantastic flowers from palms and other trees, and emitting delicious odours.—R. E.]

309 WOOLLAMS, WILLIAM, & Co., 110 *High Street, Marylebone*—Manufacturers.

Specimens of decorative paper-hanging, in flowers and ornament; and in the Alhambra and arabesque styles. Screen of various specimens of paper-hangings.

Specimens in the early Italian style, and in the mediæval style, designed at the Government School, Somerset House.

Specimens with Indian birds and flowers, in imitation of mother-of-pearl, and in hollyhock and ornament.

The design of one of these specimens is given in the accompanying Plate 38.

310 HINCHLIFF, NATHANIEL, & Co., 123 *Wardour Street, Oxford Street*—Manufacturer.

Registered paper-hangings. Panel decorations, and an arabesque panel decoration, designed by Mr. John Crace.

312 PRICE, J., *Gateshead, Newcastle-upon-Tyne*—Manufacturer.

Table, with jasper glass top.

312A TRAPNELL, H., & SON, 2 *St. James Barton, Bristol*—Designers and Manufacturers.

A console chiffonnière, of fine English walnut-wood. The top is of statuary marble, set in a moulding of ebony and tortoiseshell, with ruby-coloured glass in the end shelves, and the centre shelves and backs of plate glass, intended to give multiplied reflections of the objects placed upon the shelves.

313 NEWBERY, J. & R., 2 and 3 *Hemlock Court, Carey Street, Lincoln's Inn Fields*—Manufacturers.

Gold, silver, and coloured tissues, alike on both sides, for making artificial flowers, &c. Coloured foil papers for decorative purposes. Gold and silver paper ornaments for placing on "Irish linen bands." Vulcanized, washable, enamel coloured papers. Crimson, blue, and green papers, coloured by machinery (in any length), without seam or join.

314 NORWOOD, CHAS., *De Beauvoir Factory, Rosemary Branch Bridge, Horton*—Manufacturer.

An architectural decoration, composed of printed mouldings, figures, and wainscot papers for public buildings, halls, corridors, &c. The style is Tudor Gothic, with figures.

315 PURKISS, JOHN, & SON, *29 Old Change*—Designers and Manufacturers.

Imitation of marbles in water-colours, on paper. Sienna marble, skirting dove marble. Two coloured green marbles, worked to represent four distinct pieces; executed on a square surface, instead of pieces joined together. Skirting porphyry. Devonshire dove marble. Skirting Brocatella marble.

316 SOPWITH, T. & J., *15 Northumberland Street, Newcastle-upon-Tyne*—Inventors and Manufacturers.

Monocleid writing cabinet, for collecting and arranging a great number and variety of papers, so as to be readily accessible. The whole of the drawers, closets, and partitions may be opened by one lock.

317 TURNELL, I., *32 Pinstone Street, Sheffield*—Producer. Ladies' work-table, a specimen of English elm.

318 TOWNSEND, PARKER & TOWNSEND, *132 Goswell Street*—Designers and Manufacturers.

Paper-hanging decorations consisting of flock, flock and gold papers, flowers, fruit, and arabesque designs divided into panels.

The two principal papers are exhibited as examples of opposite styles of internal decoration; one intended to be light, graceful, and delicate, the other rich, bold, and striking. The former consists of panels on a light ground, having centre-pieces formed of groups of fruit and flowers, separated by delicately ornamented pilasters, with bunches of fruit and flowers rising from the base, and pendant from the top, the whole surmounted by a floral frieze on gold ground, and a border below in the same taste. The other decoration consists of a large panel, bearing in the centre a rich arabesque design on a light ground; the foliage being a combination of such plants as would most naturally and gracefully assume the required forms, as acanthus, crown imperial, &c. The pilasters are ornamented with designs in a corresponding style, upon a dark, rich ground, finished with a broad frieze and a border in blue, red and gold. The accompanying plates represent these designs. Plates 66 & 159.

320 TURNER, HENRY, & CO., *Elizabeth Street, Pimlico*—Manufacturers.

Paper-hangings, entirely block-printed, viz.—

1. A damask in brown flock, on a green flock ground, from a design by M. Charles Javet, of Paris.
2. A panel with flower border, from a design by Mr. William Draper, of Camberwell.
3. A chintz and border, in a series of panels, designed by M. Marchand, of Paris.
4. A panel with Elizabethan ornamental border, from a design by Mr. William Draper.

5. Four frames with Grecian moulding, printed in imitation of oak, and containing two panels in shades of green flock on a puce flock ground, and two panels in double crimson flock, in imitation of silk damask. Both damasks from original French designs; the moulding from drawings by H. N. Turner, jun. The accompanying Plate represents one of these paper-hangings.

321 WILLIAMS, COOPERS, BOYLE, & CO., *85 West Smithfield*—Manufacturers.

Drawing-room decorations. Damasks for dining-rooms. New mode of combining metal and flock. General patterns of new designs.

322 WOOLLAMS, JOHN, & CO., *69 Marylebone Lane, Oxford Street*—Manufacturers.

A general assortment of paper-hangings and decorations by block printing:—Damasks. Flower patterns and

decoration borders. Flock and metal, and two flock patterns. Bronze patterns. Panel decoration, consisting of the orange and white datura, from drawings by Miss Palmer, of the School of Design, London.

Specimens of machine printing:—Paper hangings printed by steam cylinder machinery, exhibited for cheapness and quality. From one to eight colours printed at one operation, and at the rate of 200 pieces, or 2,400 yards per hour. Registered designs.

326 JEFFREY, ALLEN, & CO., *Kent and Essex Yard, Whitechapel*—Manufacturers.

Paper printed by blocks in distemper. Specimens of a many-coloured chintz wall-paper, and of cylinder-printed wall-papers.

Frieze, executed in imitation of classical subjects, 24 feet in length, without repeat, selected from the best part of the Elgin frieze. Also, a series of panels representing "Deer Stalking;" and some copies from Murillo, printed in blocks.

A panel composed of a "green flock filling," designed by one of the pupils of the Spitalfields School of Design, from the common buttercup; intended to show that the simple forms of nature abound in elegance, and only require to be studied with care, and copied with skill.

329 DAVIS, CHARLES, *26 Blackfriars Road*—Designer and Painter.

Design of a panel for the decoration of a ceiling, in imitation of inlaid woods.

336 JONES, THOMAS, & CO., *214 Piccadilly*—Inventors and Manufacturers.

New method of decoration for the side of a room, consisting of a flock paper, relieved by panelling in high relief in gold, bounded with a border, and surmounted by an enriched cornice in white and gold. Coloured decorations for ceilings, and other specimens.

337 M'LACHLAN, JAS., *35 St. James's Street, Piccadilly*—Designer, Manufacturer, and Proprietor.

Specimens of arabesque painting on glass, for the decoration of rooms (being pilasters); also imitations of inlaid marbles on glass. Specimens of flocking on painted walls, and of arabesque painting for the decoration of rooms.

340 SEWELL, CHARLES & FREDERICK, *13 Charles Street, Westbourne Terrace*—Designers and Manufacturers.

Elizabethan ornamental screen, containing panels in imitation of various marbles and woods, adapted for interior and exterior embellishments.

341 SMITH, CHARLES, *43 Upper Baker Street*—Decorator.

Imitations of marbles, in paint, on slate and wood, for interior or exterior decoration. Grecian ornament, in paint. Arabesque decoration, in paint, for drawing-rooms, boudoirs, &c.

342 SOUTHAL, CHARLES, & CO., *157 Kingsland Road*—Manufacturers.

Half top of table in imitation marble, inlaid. Slab, in imitation rouge royal marble. Imitation marble and woods, worked on paper, for decorating staircases, halls, &c.

343 STRUGNELL, HENRY, *25 Kirby Street, Hatton Garden*—Designer and Manufacturer.

Ladies' writing-desk, in ebony and buhl-inlaid, with newly-introduced fancy edges. The internal arrangement designed by Mr. Wathen, of Glasgow.

344 HAYBALL, ARTHUR, *Government School of Design, Sheffield*—Designer.

Cabinet, carved in walnut.

345 HOYLES, HENRY, *Government School of Design, Sheffield*—Designer, Modeller, and Carver.

Sideboard, carved in walnut.

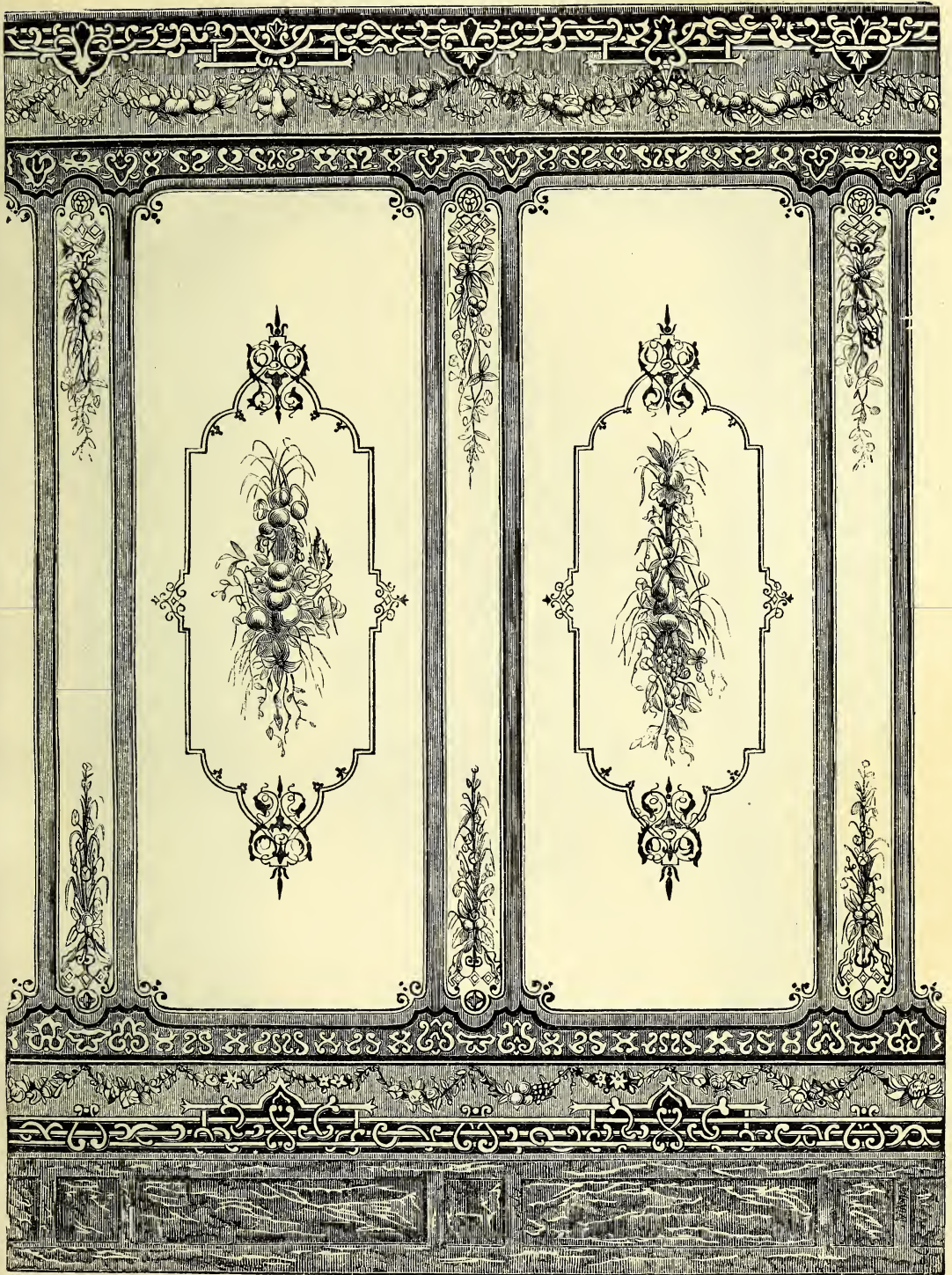





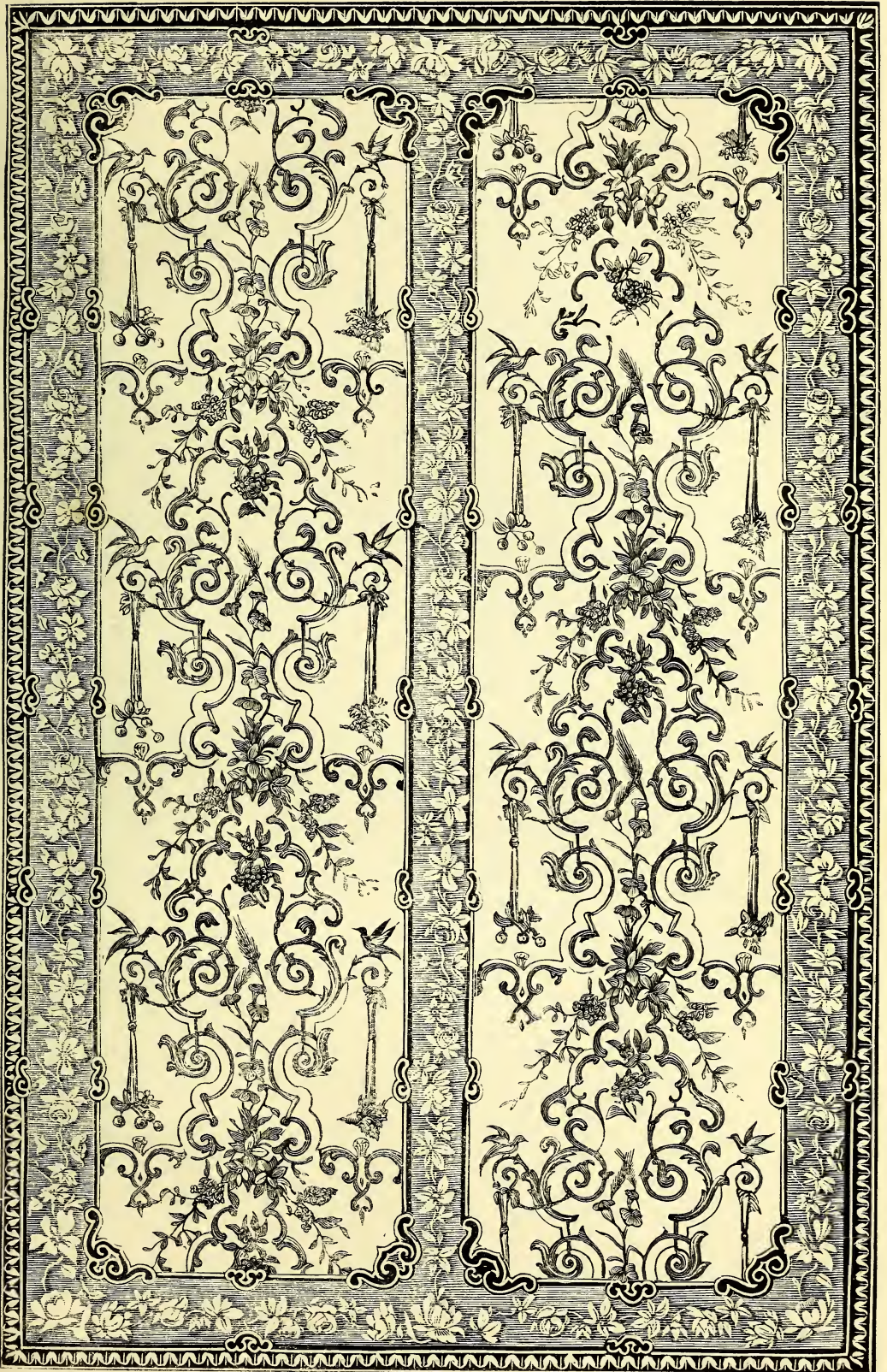

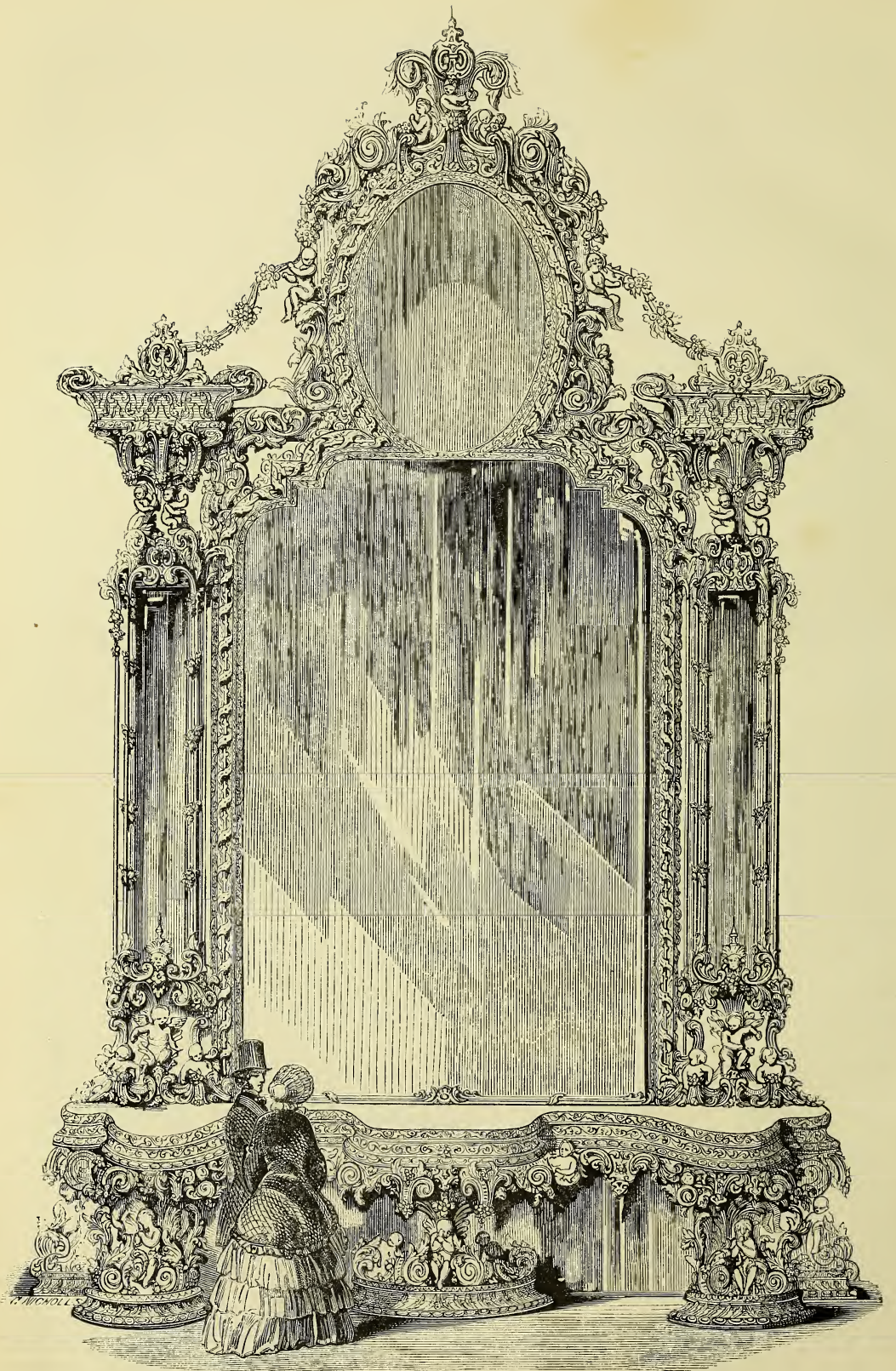

346 STEEDMAN, CHARLES, 35 *Charles Street, Hampstead Road*—Manufacturer.

Slate tablets, japanned and ornamented, adapted for churches and other buildings. (In Class 1, on South Wall.)

347 PICKERING, J., 39 *Little Moorfields*—Producer.

Specimen of drawing-room panel decoration, executed in colours and gold. The centre, illustrative of the "Bath of Apollo," in basso-relievo, and the border enriched with figures and flowers in natural colours. The centre in colours, illustrative of "Poetry surrounded by attendant nymphs," with enriched flower pilasters, &c.

361 BURKE, JAMES HASWELL, 75 *Castle Street East, Oxford Street*—Designer and Manufacturer.

Fancy mounts and spandrels for drawings, prints, &c., in card-board and gold paper.

364 FOLLIT, GEORGE, 67 *Great Titchfield Street, Marylebone*—Manufacturer.

Specimen of an imitation or-molu gilt mat flat, made of paper and not liable to split.

365 NEWNHAM, BEN., 22 *Princes Street, Leicester Square*—Inventor and Manufacturer.

Miniature frames in imitation of or-molu.

369 FURSE, CHRISTOPHER & SEPTIMUS, 4 *Hanway Street, Oxford Street*—Manufacturer.

Washable gilding, as applicable to looking-glasses, picture frames, cornices.

379 HERRING, C., 177 *High Holborn*—Producer.

Oriental silk down, from the Bombax tree of India.

380 BAXTER, ROBERT, 12 *George Street, Foley Place*—Designer, Manufacturer, and Proprietor.

Frames, illustrating the art of gilding, as applied to picture and glass frames, cornices, &c.

Letters cut out of the whitening, and gilt in burnish, showing the different-coloured gold and silver leaf; colours used in contrast with gold, showing the method of gilding ornamental frames.

382 VIGERS, E., jun., *Union Mills, Upper Lisson Street, Paddington*—Manufacturer.

Mouldings, architraves, skirtings, and sash-bars, prepared by machinery.

384 JORDANS, —, *Belvidere Road, Lambeth*—Manufacturers.

Circular table of walnut-tree, and two Davenport's and three chairs, all finely carved.

385 ARROWSMITH, H. & A., 80 *New Bond Street*—Designers and Manufacturers.

A decorated cabinet in zebra wood and gold, nicely carved; the four panels illustrating "Woman's History," the two upper compartments, removable, and arranged for writing materials, and ladies' work.

Specimens of patent lace curtains, resembling the most elaborate point lace; of patent damask curtains, resembling cut velvet pile curtains; and of a new pattern line curtain, lined with pink silk, adapted for windows, bedsteads, &c.

New dry process of cleaning carpets, curtains, tapestries, needlework, and similar articles of furniture.

386 McLEAN, CHARLES, 78 & 110 *Fleet Street*—Manufacturer.

Large looking-glass and console table, ornamented and gilt. (*Main Avenue West.*) This glass is represented in the Plate 28.

389 AVERY & DANGAR, 11 *Great Portland Street*—Manufacturers.

Shutter blind for the Ambassador's new Palace at Constantinople.

Improved outside Venetian blind. Improved outside bonnet blind, set high or low at pleasure; or constructed so as to draw up into the soffit of a window when not in use.

White holland spring blind adapted to casement windows.

390 BURT, HENRY POTTER, 238 *Blackfriars Road*—Inventor.

Improved patent window-blinds, composed entirely of metal. They admit of variety in pattern, are applicable for out-door use, and especially adapted for warm climates.

391 AUSTIN, JAMES, 8 *Princess Street, Finsbury*—Manufacturer.

Patent sash and clock lines, manufactured from flax; blind lines, from flax, silk, cotton, and worsted; and lamp and picture lines from silk and worsted.

392 WELLS & Co., *Bedford*—Producers.

Table tops made of English oak, grown at Ampthill Park, the property of the Duke of Bedford. (*South Wall.*)

[A survey of this park, by order of Parliament in 1653, describes 287 trees as hollow and too much decayed for the use of the navy. The oaks thus saved from the axe remain to the present day the picturesque ornament of the place.]

395 HARRIS, HENRY GEORGE, 528 *New Oxford Street*—Manufacturer.

Patent perforated transparent roller blind, made of the common prepared muslin, ordinarily used for transparent painting.

[The perforations are made by placing the muslin upon metal blocks, and then gently rubbing those portions of the muslin to be perforated with a piece of fine sand-paper or pumice-stone, until the muslin in those parts is ground away. By this process a variety of patterns may be produced with one block. They are adapted to warm climates, the air being freely admitted through the perforations; they exclude the sun from an apartment, and at the same time render exterior objects visible from it.]

396 KOBELT & SONS, 22 *Newcastle Street, Strand, and 17 Cross Street, Blackfriars Road*—Inventors and Manufacturers.

Ornamental spring-roller blind; enclosed in a brass case, to preserve the linen from dust; the spring works on brass; with improved cog-plate cap and lever, which reduces the roller one quarter of an inch.

397 LUCAS, PHILIP, jun., 19 *Hyde Park Gardens*—Inventor.

Rotatory shop-blind.

399 THAMES PLATE GLASS COMPANY, *Bow Creek, Blackwall, Warehouse, Savoy Wharf, Strand*—Manufacturers.

Large specimen of plate glass, the largest hitherto produced. Large silvered plate. (*Centre Avenue.*)

400 NOEL, HENRY WILLIAM, 37 *High Street, Camden Town*—Designer and Manufacturer.

Painted transparent window blinds, in imitation of stained glass; for library or staircase windows. Chinese bird blinds for drawing and sitting rooms, boudoirs, &c.

401 GRIGG, JOHN, *Bunwell, near Wells*—Inventor and Manufacturer.

Ornamental rustic arm-chair, containing 3,000 pieces of wood, with a picture of the Exhibition inserted, which contains 500 pieces, made from natural colour woods.

Mechanical pictures:—view of Knox's house, in High Street, Edinburgh, contains 1,200 pieces of inlaid wood, all natural colours. Balmoral Castle, the residence of

Her Majesty, in the Highlands, contains 700 pieces of inlaid wood, and 700 pieces in the frame, all natural colours. Residence in the Highlands, where Her Majesty entertained the different clans, when they performed their various feats; contains 300 pieces of inlaid wood, all natural colours.

402 LEE, GEORGE L., 245 *High Holborn*—Prod cer.

Imitation stained glass and marbling on surfaces by the water bath.

403 PRATT, HENRY, 123 *New Bond Street*—Inventor and Manufacturer.

Patent travelling wardrobe, with double folding lids, drawers and spaces for hat, made in scarlet morocco, solid leather, gilt, and lined with satin.

Ladies' patent travelling wardrobe, with double folding lids, drawers, and space for bonnets, covered in scarlet morocco, decorated and furnished inside with Genoa velvet and satin.

Patent compendium portmanteau, with expanding bag, made of scarlet morocco on solid leather, gilt.

Officer's portable brass bedstead, to form sofa, with the exhibitor's patent spring mattress and musquito curtains.

Portable brass chaise lounge with elastic gutta percha sacking.

Travelling chair in brass, to form couch and bedstead.

The above patents for wardrobes were obtained July 9th, 1850, and specified Jan. 9th, 1851.

404 DOWBIGGIN, THOMAS, 23 *Mount Street, Grosvenor Square*—Manufacturer and Designer.

Commode, of various woods; the panels ornamented with marquetric and carvings, and painted china in the centre. The pilasters of painted china, with metal caps, chased and gilt: the whole finished with chased and gilt mouldings.

Walnut carved bedstead and cornice, with temporary hangings.

405 AULDJO, MRS. T. RICHARDSON, *Noel House, Kensington*—Producer.

Table made of wood found in a villa near Pompeii.

In the summer of 1835, Colonel Robinson, at that time director of the Royal Manufactory of Gunpowder of Naples, having occasion to make some excavations near Pompeii, in connexion with the water supply to the gunpowder works at Torre dell'Annunziata, came upon the remains of a Roman villa. On examination it appeared to have been under process of repair when overwhelmed by the same catastrophe which destroyed Pompeii A.D. 79. At the principal entrance was found a large beam of wood, squared and ready, probably to be used as the lintel of the door. It was apparently completely charred, and was strongly impregnated with the odour of carbonic acid gas. On being touched, however, the outer parts crumbled into dust, but the centre proved to be sound and as black as jet. This is now exhibited as a specimen of some of the oldest wood probably in existence, for, from the size of the beam, the tree from which it was prepared must have been at least 200 years old when cut down. This remnant of the beam was kept for two years exposed to the air, to free it from the strong smell of carbonic acid gas, and was then sawn into veneers, of which two tables were made. They were mounted in London on pedestals designed from a bronze candelabrum in the Royal Museum at Naples.

406 MARTIN, JOHN, 45 *Southampton Row, Russell Square*—Manufacturer.

Walnut-tree chair, with portrait on the back.

407 HOLLAND, WILLIAM, *St. John's, Warwick*—Designer and Producer.

Half-sized door, painted in imitation of oak, inlaid with ebony and pearl; suitable for dining-rooms or libraries. Another, polished white enamel, with gold mouldings; adapted for drawing-rooms.

Two half-size doors, imitation of walnut, inlaid with flowers, &c., in various woods, to harmonize with marquetric furniture, and floors; suitable for ladies' boudoirs, drawing-rooms, &c. Another, painting, with figures in the Pompeian style, adapted for saloons. Another, in the Elizabethan style, with composition ornaments to imitate carved oak; suitable for libraries.

Half-size door, in the Louis Quatorze style; adapted for drawing-rooms, saloons, &c. Another, with plate-glass panels, embossed with gold and silver; suitable for drawing-rooms, saloons, boudoirs, &c.

Miniature specimens of wall decorations for dining and drawing-rooms, libraries, boudoirs, picture galleries, &c.: with composition ornaments enriched with gold and silver upon crimson velvet, with badges in corner ornaments: with green watered silk panels and enriched mouldings; with embossed and silvered plate-glass smaller panels. Blue silk panels and gilded composition corners. Tinted in party colours and gold. Elizabethan style, in gold and various coloured flocks, with arms emblazoned, and imitation of carved oak corners. Ornamented flock panels and composition corners.

Any design or description of ornament, coats of arms, &c., can be introduced to any scale in flock upon the walls of rooms without the use of paper.

Imitation marbles for walls of staircases, entrance halls, corridors, &c. Specimen of imitation of marble on plate glass.

Three specimens of imitation of inlaid marbles upon slate, in imitation of Florentine tables. Imitation inlaid woods for marquetric tables.

Specimens of the exhibitor's newly-invented method of staining woods to borders of marquetric floors; designs to suit the different styles of building.

Newly-invented flocking machine, for flocking walls, &c.

408 BRITISH PLATE GLASS COMPANY, 1 *Albion Place, Blackfriars, and Ravenhead, St. Helen's, Lancashire*—Manufacturers.

Two specimen looking glasses, each upwards of 12 feet high. (*Main Avenue, West.*)

526 COWELL & THOMAS, 103 *High Street, Marylebone*—Designers and Manufacturers.

Specimen of solid inlaying, by hand, intended for floors of drawing-rooms, boudoirs, ball-rooms. Executed in deal and mahogany, in boards of the ordinary width.

527 MARSDEN, CHARLES, *North Place, Kingsland Road*—Manufacturer.

Specimens of marble and other paper hangings for halls, staircases, &c.

528 ENGLAND, G. W., *Leeds*—Designer and Manufacturer.

Dining-room chair, mahogany, showing a novel mode of construction. The back in one piece of wood, the seat-frame only two joints in front, different shades of colour avoided, and the wood running in one uniform direction.

Library chair in oak, made in the same way.

Library ink-stand in rosewood.

MEDIÆVAL COURT.

529

PUGIN, MESSRS.

Various articles for the ornament and decoration of churches, &c..

530 CRACE, JOHN GREGORY, 14 *Wigmore Street*—
Manufacturer.

Furniture and decoration in the mediæval style.

Side board, in carved oak.

Oak cabinet bookcase, in carved oak, with ornamental brass work.

Octagon and writing table, in carved walnut wood, with inlaid top.

Carved oak bench. Tables and lecterns. Carved prie-dieu, with tryptic over. Oak screen with needlework, by Miss Bifield.

A carved pianoforte, and a carved gilt pianoforte, made by Lambert and Co., 1 *Werrington Street, St. Pancras*.

Tapestry damask in silk and wool. Silk brocatelles. Woollen stuffs for hangings. Chintzes. Axminster, Brussels, and velvet pile carpets.

Decorations in the mediæval style.

531 MINTON, H. & Co., *Stoke-upon-Trent, Staffordshire*
Manufacturers.

Ornamental tiles, porcelain, and painted ware.

532 HARDMAN, JOHN, & Co., *Great Charles St., Birmingham*
—Manufacturers.

Brass lecterns, with book-desks, and figures of various kinds.

Altar, with brass pillars, and other appurtenances, in the old French style.

Candlesticks, with various ornamental figures, in antique style.

Brass table, with inlaid marble top. Hanging-beam for lamps.

Plated metal candlesticks, beaten and engraved. An iron candlestick. Brass ornament for altar.

Corona, intended for a large parish church. Brass chandeliers, of new designs, for churches.

Small brass corona. Brass stands, with branches for lights. Brass book-stands and candlesticks, with various ornamental figures.

Monumental brasses, with various figures and ornaments.

["Beaten work" is produced by being raised by means of a hammer, on variously formed stakes or anvils; the figures, or ornaments, are produced by being punched up thereafter. The interior of a vessel or ornament is filled with some substance, say pitch, and, by means of small tools, the workman completes the design; these works are always produced out of thin plates of metal; the art of the engraver then follows, and, in the higher class of objects, when not formed of a precious metal, they are "parcel" gilt, that is to say, certain portions of the surface are gilt, which are confined within given spaces, by outline engraving. The enameller occasionally lends his aid to produce rich colouring. Enamel is produced by heat; it is, in truth, a coloured glass, which is ground down in some volatile substance, and applied in a fluid state with a brush, and which the heat of a muffle fuses, and renders a transparent substance, which is occasionally polished. The enamellers of Limoges were celebrated for their excellence in this department of fine art manufacture.

By "pierced work," is understood the perforated scroll metal work, which adorned many of the hinges and other articles; this was originally done by means of small saws; it afforded abundant room for the exercise of taste and originality.

In the brass working a difference will be detected in the degree or appearance of finish; this arises from every

portion of the work being polished, by means of which the natural colour of the brass is shown. In modern brass-foundry acid-finish is the rule, the polish-finish the exception. Every portion of the work, in the latter case, is filed carefully over, and finished by brushing, with revolving brushes, with rotten-stone and oil, a charmois skin and the same material clears it up, and the whole is protected from tarnish by a light lacquer.

Monumental brasses are formed out of rolled metal, and the designs and inscriptions incised by means of the graver's tools; the hollows, or incisions, are filled up with a hard wax; in some of the older specimens a kind of enamel was used. After the brass work is completed the same is inlaid in black marble, or Purbeck stone, according to taste.—W. C. A.]

Brass chandeliers, with branches, in the style of the 15th century. Coronas, brass hall-lanterns, and candelabra. Brass candlesticks, for tables. Brass beaten alms dishes. Looking-glass, mounted with brass.

Painted glass windows for halls, chapels, and churches, containing various figures and ornaments. Various specimens of tracery. The glass manufactured by Messrs. Lloyd and Summerfield, Birmingham; and Messrs. Hartley and Co., Sunderland.

[Considerable advance has been made in the art of glass staining, or painting. Transparency and brilliancy of colour are now obtained by several of the English glass painters. The colours employed are principally metallic oxides. The process of painting a glass window may be thus described:—a cartoon is made of the subject intended, which is, in the majority of instances, transferred to the hands of the workmen who are to apply the colour; when this is done, the glass, with the colour applied, is subjected to the heat of a muffle, and is fused. "Pot metal" is occasionally used, that is, metal which has been made in a furnace, with the colour incorporated with the glass when in a state of fusion: "flashed glass" is also used, and is made by the covering a ball of glass with coloured glass, by blowing it into the form of a globe, and then finally flashing it, or throwing it into a horizontal disc, from which pieces are cut—the details are then added, and the glass is put into the hands of the glazier, who leads it together, and forms the window.—W. C. A.]

Embroidered robes of white and gold brocaded silk, red velvet, red and gold brocaded silk, white silk brocade with gold thread, with hoods, capes, girdles, &c. Various specimens of embroidery, chain stitchings, silks, laces, &c. Designed by A. W. Pugin, Esq.

533 MYERS, GEORGE, *Ordnance Wharf, Lambeth*—
Manufacturer.

Font and cover in the style of the fifteenth century, the four panels contain "The Fall of Man," "Baptism of our Lord," "St. John preaching in the Wilderness," and "The Crucifixion." Tomb to be erected in St. Chad's, Birmingham, for the late Dr. Walsh. Reredos and altar. Stone tabernacle. Rood for the screen of a chapel. Compartment of the screen for a church. Oak bench for a parochial church. St. John the Baptist, in oak, on corbel. Stone altar for the chancel of a parish church. Stone fire-place. Compartment of staircase. Oak cabinet in the style of the fifteenth century.

Copper casement, designed for a lunatic asylum.

534 BIFIELD, CAROLINE, 6 *Canonbury Place, Islington*—
Designer and Proprietor.

Screen:—St. George and the Dragon, with the arms of the United Kingdom encircled by the national emblems; also, containing the arms of the Queen, Prince Albert, Prince of Wales, the Duke of Wellington, and Sir Robert Peel, in an ornamented oak frame.

535 DU CANE, A., *Witham*—Designer.

Casket to contain a lock of hair.

536 TUCKER, F., & Co., *Kensington*—Manufacturers.

Wax candles for church and domestic purposes; made by hand and not in a mould, twisted triple, and painted; exhibited for novelty.

DECORATIVE CEILINGS.—SOUTH OF NAVE.

Bay M.

21 TROLLOPE & SON, 15 *Parliament Street*.

22 JACKSON & SONS, 49 & 50 *Rathbone Place, Oxford Street*.

23 JACKSON & GRAHAM, 37 & 38 *Oxford Street*.

24 CALLI & COTTI.

UNDER SOUTH GALLERY.

Bay P.

15 JONES & Co. (late ROBSON & JONES).

1 LITHGOW & PURDIE.

NORTH OF NAVE.

Bay I.

19 JACKSON & SONS, *Rathbone Place*.

20 A. HERVIEU, 10 *Portugal Street, Grosvenor Square*.

21 HENRY CROUGHTON, 100 *Upper Street, Islington*.

22 RICHARD THOMAS, *Circus Road East, St. John's*

Wood.

23 } SCHOOL OF DESIGN, *Somerset House*.

24 }

25 C. F. BIELEFIELD, 15 *Wellington Street North, Strand*.



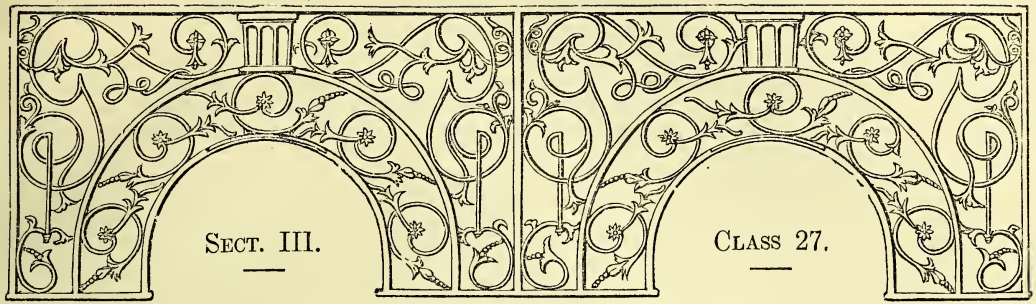

MANUFACTURES IN MINERAL SUBSTANCES, FOR BUILDING OR DECORATIONS.

INTRODUCTION.

THE first of the thirty Classes of the Exhibition has a close relationship with the present Class. The first Class, comprising the raw material, and this its application to use and conversion into definite form, their connection becomes more evident than between other of the Classes of raw materials and manufactures. Thus it may be said that Class 4, including vegetable and animal substances used in manufactures, was only remotely connected with several other Classes, such as cotton, silk, flax, woollen, leather, &c. The same cannot be said with reference to the Class just named—its connection with mineral manufactures is immediate and obvious. In some respects, the present Class deserves to be noticed as presenting a contrast to several of the preceding Classes of manufactures. In many of the preceding Classes, the preponderating influence in the manufacture has been generally of a mechanical kind, the material itself undergoing little amount of physical change. To this the exceptions of glass and ceramic manufactures must, however, be made. In the present Class, although largely consisting of specimens of raw material operated on exclusively by mechanical force, divisions are recognised which comprise processes in which the agency of chemical laws, and of those of heat, is necessary to the success of the manufacture. Of this kind are the cements, artificial stones, plasters, compositions, &c., forming a most important Class of substances in themselves, and extremely well represented in the Exhibition. In the manufactures in stones, slates, &c., the raw material is presented to notice precisely in its natural state as regards its physical character, the form and polish having been communicated mechanically; but, in the substances just mentioned, mechanical force is only subsidiary to that powerful display of chemical affinity which, on the mere application of water, binds together the particles of an incoherent powder into a solid and stone-like mass. To this, in the process of hardening, form is given either by moulds, or by appropriate tools in the hands of the workman.

The following Sub-Classes are recognised:—A. Manufactures in common Stones, as for building, and for decorative purposes; B. Manufactures in Slate, for construction or for decoration; C. Manufactures in Cement and artificial Stones; D. Manufactures in Marbles, Granites, Porphyries, Alabaster, Spar, &c., for useful and ornamental purposes; E. Inlaid work in Stone, Marble, and other mineral substances; F. Ornamental work in Plaster, Composition, Scagliola, imitation Marble, &c.; G. Combinations of Iron and other metals, with Glass and other substances, for various useful purposes.

In the Building, the objects belonging to this Class are placed generally in Areas G. H. 14 to 17, and I. J. 16 to 17. These will be found on the North side of the Western Main Avenue, midway between the Transept and Western Entrance. But in the Avenue itself several large objects are placed which belong to this Class. Among these are the specimens of stone-carving, the fountains, madrepore columns, &c. Outside the Western Entrance, also, a number of articles are exhibited which are included here, such as the specimens of cement, of pipes in earthenware, of ornamental bricks, &c.

The geological character of a locality in this instance will be found, as might be reasonably expected, to determine the peculiar contributions forwarded from thence to the Exhibition. Thus, from Derbyshire, Devonshire, Cornwall, &c., as might be anticipated, are sent specimens of marbles, granites, porphyries, alabaster, spars, &c.; for, in the districts represented, that natural mineral wealth exists in great abundance, examples of which are shown. The same remark applies to the slates sent from Wales, &c. The Metropolis, in which building operations are carried on to an extent equalled by no other capital in the world, might be naturally supposed to be the largest exhibitor of cements and artificial stones, and such is accordingly the fact.

Some very large specimens of slates, applied to purposes of domestic utility, as for cisterns, &c., are exhibited outside the Building. The cohesive power of cements is shown in a variety of ways, and in several combinations, as with pebbles, hollow bricks, &c. The method adopted to illustrate the strength of the cement is to unite two surfaces with it, and by iron clamps let into the stones above, and that below, to apply a force calculated to separate the joined portions. By using pigs of cast-iron, slung by chains to the lower clamps, and by adding gradually to their number, the precise point at which the weight overcomes the cohesive attraction of the cement may be simply ascertained, the area of the surface united always, of course, forming an important element in the calculation. Other circumstances being similar, that cement is considered the most powerful which requires the heaviest weight to disunite the surfaces. In order, however, to gain accurate knowledge of this fact, these experiments should be conducted with care and precision, otherwise the results may be wholly deceptive. These cements may be, and are, in fact, practically included indifferently either in Class 1 or Class 27. It is principally in their application not so much as a cement as for the

formation of a plastic material for architectural or ornamental purposes that they have been regarded in the arrangement of this Class—Class 1. containing a number of exhibitors of these substances. For the latter purpose, however, their power of cohesion, accompanied with their adaptation to manipulating processes, form their most valuable properties.

A variety of articles for use and ornament, formed of cements of different descriptions, are exhibited. The application of these substances to wall-decoration is illustrated by some beautiful specimens, so closely imitative of marble as to be with difficulty distinguished from that material. The applications of terra-cotta, also, are increasing, and various objects formed of this material are shown. Among others, the model of a church, formed of terra-cotta, may be considered as an interesting illustration of the uses of this substance. The model represents a real structure, which is entirely built of terra-cotta, as a substitute for bricks, &c.

Machinery has been applied recently with much success to carving objects in wood and also in stone, and the results are exhibited in some fine specimens. The Derbyshire marbles, as worked by mechanical power, are shown. The serpentine of Cornwall, naturally an extremely beautiful and ornamental stone of a rich body colour, and relieved with brilliant veins of white, have been formed into pedestals, vases, tables, and other articles which are exhibited in this Class. Cannel coal has often been applied to ornamental uses for which, in consequence of its not soiling the hands, and its capability of receiving great brilliancy of polish, it forms a very appropriate material. A block of parrot, or cannel coal, is exhibited in this Class by H. R. H. Prince Albert, together with a garden seat made of this substance, which has been, in this instance, derived from West Wemyss colliery, in Fifeshire.

The sections of cottages, built with hollow brickwork, glazed and unglazed, will receive much attention. The conditions proposed to be satisfied by this method of building are those of dryness, warmth, durability, security from fire, deadening of sound, and economy of construction. The model cottages exhibited by H. R. H. Prince Albert, near the South-eastern corner of the Exhibition Building, Outside, have been constructed with these bricks, and embody several other valuable and ingenious features in their arrangements.—R. E.

1 KERSHAW, THOMAS, 35 John Street, Fitzroy Square—
Painter.

Imitation of foreign and English marbles and woods, for house decorations; made of wood and slate.

3 BRENDON, WILLIAM STERT, Yeolm Bridge, near
Lannceston—Proprietor.

Chimney-piece, with portion of pavement and skirting; suitable for an entrance hall, designed by Walter Damant, architect, of Plymouth, and executed by James Bovey, statuary, in Yeolm Bridge slate and polyphant freestone.

4 BOVEY, J., Plymouth, Devon—Manufacturer.

A chimney-piece, suitable for a hall or library; designed by Oswald Cornish Arthur, architect; executed in black marble, and inlaid with variously-coloured marbles, found in the neighbourhood of Plymouth.

A font, in the perpendicular style, designed by Walter Damant, architect; executed in limestone marble. The step is of Dartmoor granite, inlaid with specimens of Plymouth marble.

The marble contains abundance of fossil remains, and is capable of receiving a fine polish by ordinary hand labour.

5 FREWER, JAMES, Woodbridge Road, Ipswich—
Designer and Manufacturer.

A Caen stone carved chimney-piece.

6 CHAMPERNOWNE, HENRY, Dartington House, Totnes—
Proprietor.

Circular table of bright chocolate-coloured marble.

Various specimens of the marbles, showing their adaptation to decorative purposes.

[The marbles of Devonshire are often coralline, but generally very crystalline and much altered, the fossil remains being more or less obliterated. They often exhibit veins, and are varied and rich in colour. The chief objection to them in working, arises from the frequent irregularity of texture they present, and their brittleness. Where more uniform, they may be manufactured for various ornamental purposes.—D. T. A.]

7 MAYO & Co., 17 Silver Street, Wood Street, Cheapside—
Inventor.

Patent syphon vases, for containing aerated or gaseous mineral waters. They afford the means of withdrawing at pleasure such quantities as may be desired, whilst that which remains for subsequent use retains its purity and

effervescence. The vases exhibited are specimens of the combination of metal with pottery. The process of manufacture is the invention of the exhibitor.

8 WILLOCK, E. P., 10 Exchange Arcade, Manchester—
Producer.

Specimens of Ladysshore terra cotta.

9 HUMBLE, WILLIAM, 35 University Street, Bedford
Square—Designer and Manufacturer.

Marble octagon table top, supported on carved wood column and base; the top contains 700 pieces, and 30 different qualities of rare and beautiful marbles, 10 English and 20 foreign, inlaid in various forms.

11 WILSON, J., Stratford, Essex—Manufacturer.

Chess-table, painted in imitation of marble.

12 HARTLEY, THOMAS HENRY, Westminster Marble
Works, Earl Street, Holywell Street, Millbank—
Proprietor.

Gothic stone mural monument of new design, with octagonal piers, carved ornaments, and red granite polished panel for inscription. Exhibited for workmanship.

13 EKINS, GEORGE, Ware, Herts—Manufacturer.

Slate coffin, with copper screws; exhibited as perfectly air-tight.

14 WILSON, S., Grimley, Notts—Producer.

Slab painted in imitation of marble.

17 THE LONDON MARBLE AND STONE WORKING
COMPANY, Esher Street, near Millbank, Westminster—
Importers, Designers, and Manufacturers.

Grecian column chimney piece of white Carrara marble. Hexagon and octagon Gothic fonts, in the perpendicular style, of white Carrara marble.

Model of a bracketed staircase, worked in Irish black marble, for the Duke of Hamilton. This work comprised forty-one steps and four landings, of the following dimensions, viz., one, 10 feet by 7 feet; two, 7 feet square; and the top 38 feet long by 9 feet wide, in 5 pieces; also, 125 square balusters, 2 feet 6 high, with hand-rails in one length of 16 feet; worked and polished by the Company's machinery; the invention and patent of James Tullock, Esq., F.R.S.

Table and slab of coloured marble.

- 18 **MIRROR MARBLE COMPANY**, 16 *Castle Street, Southwark Bridge Road*—Licensees under Patent and Manufacturers.

Specimens of a new patent mantelpiece, made entirely of iron and glass. The surface of the iron is japanned, but finished in a peculiar manner, or it may remain with the common Berlin finish, a specimen of which is also shown. Thick plate glass panels are introduced, which being marbled or painted from behind, give the mantelpiece the appearance of fine marble. A mirror is added within an iron frame, with a border in blue and gold.

- 19 **COATES, E. J.**, 13 *Broad Street, Watling Street*—Proprietor.

Chimney-pieces, made exclusively of iron and glass. Patented.

- 20 **VAUGHAN, JOHN**, *Bath*—Proprietor.

Vase and pedestal, showing the quality of Bath stone.

- 21 **BLACKBURN, BEWICKE**, *Island of Valentia, Kerry, Ireland*—Manufacturer.

Specimens of slate slabs, from the island of Valentia, Kerry, and of slate:—

Sash bars, similar in form to the wooden ones used in the roof of the Exhibition building.

Roof ridge carved in slate by machinery, designed by Benjamin Woodward, Esq., architect.

Park or garden seat, carved in slate.

Table exhibiting the surface of the slate polished.

Slate is said to expand and contract like glass, to be more durable than wood, and to require no paint.

The Valentia slate quarry is worked in the form of a vast tunnel 100 feet high, and 150 feet wide at the base, running into the side of the mountain on a level. Cranes traverse the top of the tunnel. The slate is not blasted, but raised by wedges in blocks of about a foot thick; and being too tough to split, is sawn into slabs of any desired thickness.

- 22 **BETTS, EDWARD LADD**, *Aylesford, near Maidstone*—Proprietor.

Terra-cotta vase.

- 23 **DOULTON, HENRY & Co.**, *Lambeth*—Manufacturers.

Glazed stoneware drain and water-pipes.

[The Lambeth stoneware is a perfect kind of pottery, approaching very nearly to a true porcelain. It is composed of clay and flint, and exposed to such a degree of heat as is sufficient to produce a partial vitrification. This ware is glazed by throwing salt into the furnace at a certain stage of the process, which is diffused by the intense heat over every part of the surface, and the soda combining with the silica of the body forms a perfect glass.—R. H.]

Specimens of architectural ornaments in terra cotta; of vases, garden pots, &c.

Ward's cases for the growth and cultivation of ferns, in terra cotta.

[Ward's cases are made nearly air-tight, but not entirely so, by which plants of the fern family and habits are protected from the injurious influences of a London atmosphere, owing to the very gradual supply of air which these plants receive, and the process of filtration to which it is subjected. In these cases, ferns grow very healthfully in the most crowded city.—R. H.]

- 24 **STEVENS & SONS**, 186 *Drury Lane*—Manufacturers.

Martin's cement for plastering internal walls, ceilings, skirtings, and floors; also for plain and coloured mouldings, castings, and decorations. (*On South Wall, S. 21.*)

- 25 **MOORE, ALEXANDER**, 19 *Arthur Street, Belfast*—Manufacturer.

Table—the leaf painted in imitation of marble and spar, inlaid. The pedestal in imitation of statuary marble,

painted by a new process. The polish was produced by manual labour alone, without the aid of either oil or varnish.

- 26 **PAGE, H. C.**, 28 *Commercial Road South, Pinlicko*—Manufacturer,

Marble prepared to resist the effects of grease and dirt.

- 27 **KEENE, RICHARD WYNN**, 124 *Vauxhall Walk, Lambeth*—Inventor and Manufacturer.

Samples of mosaic pavement, in terra cotta and other vitrified substances. In this process the tesserae forming the pattern are cemented by vitrification to the base (tile or slab), which cannot be displaced or disturbed by wear or the action of the foot, and each pattern is produced from a die, being struck from a press at the rate of two per minute. The usual process of forming each pattern with separate pieces or tesserae is thus superseded. This mosaic may be manufactured from any plastic material, *i. e.*, terra cotta, Parian china, porcelain or pottery-ware, brick-earth, cements, &c., or from glass in the molten state, direct from the furnace.

[The method of preparing tesserae for mosaic work in clay and other material was invented by Mr. Prosser, of Birmingham, in 1840.—D. T. A.]

First samples of "Parian" (vitrified), applied to architectural purposes, &c. by the exhibitor.

Ionic capital, designed by Charles Barry, Esq., for the Reform Club House, Pall Mall. Executed in Parian by Messrs. John Rose & Co., Coalport, Shropshire.

- 28 **ILES, CHARLES**, *Bardesley Works, Birmingham*—Inventor and Manufacturer.

Pedestals and slabs, being specimens of patent imitation marble for internal decoration, &c. The mode of production is new.

The method employed is applicable to all kinds of marble. Fibrous materials are used for producing the marbled effect; they have not previously been employed for this purpose. It is stated that this material can be produced very cheap—in some instances as economically as common plaster.

[The introduction of a cheap mode of giving permanent patterns and colours to the more durable kinds of plaster, effected in the objects here exhibited, is well worthy of notice. The fibrous material is so completely and yet so simply mixed up as to justify the claim to special notice.—D. T. A.]

- 29 **HENSON, ROBERT**, 113 *Strand*.
Mineral mosaic table.

- 30 **VOKINS, CHARLES**, *Pinlicko Wharf, Wilton Road*—Designer.

Chess board and men, made from coal and gypsum.

[The coal used for purposes of decoration is generally of the kind called cannel, which much resembles jet, and is highly bituminous but clean. Such coal is found both in the Newcastle and Lancashire coal-fields in abundance, but also less abundantly in others. The objects made from it are generally very brittle.—D. T. A.]

- 32 **READ, W.**, 28 *Dorset Street, Portman Square*—Designer and Executor.

Imitations of various kinds of marbles in paint, on slabs—Brocatella marble, black and gold, rouge royale, Verd de mere, Sienna marble, verdantique, jasper, berdilla, griotte, and a group of inlaid, various specimens.

- 33 **STEWART, WILLIAM**, *Rhodeswell Road, Limehouse*—Proprietor.

Ancient slab of Agra marble, inlaid with agate, cornealian, and other stones. From the palace of Akbar Khan, Cabool.

35 BRADLEY, JOHN, *Fore Street, Exeter*—Designer and Manufacturer.

Table painted on slate, in imitation of Devonshire marbles.

36 ORSI & ARMANI, 6 *Guildhall Chambers, Basinghall Street*—Patentees and Manufacturers.

Patent metallic lava pavement and ornamental slabs; also a table in the Moorish style, intended for the President of the French Republic. This material is a new combination of known substances which may be worked into a variety of colours and patterns. Its principle uses are for floorings, for the interior and exterior of buildings, in imitation of the most ancient and modern marbles, and complicated mosaics, either polished or unpolished.

Patent modern Venetian stucco, consisting of specimen of "blanc statuaire," &c. Column, table, and column of cast iron, coated. A peculiar feature in this stucco is its applicability to coating all kinds of metal. By this process the metal is prevented from being acted upon by atmospheric influences.

Stone, with marble-like polish, subject, Virgin with infant; piece of cornice; stone pedestal. By this process, stone columns, and carving of every description, are made closely to resemble marble.

37 & 38 HALL, J. & T., *Marble Works, Derby*—Manufacturer; TENNANT, J., *Strand*—Importer.

Specimens of articles manufactured by aid of steam machinery, at the Derby Marble and Spar Works.

Chimney-piece of black marble, from the quarries of the Duke of Devonshire. Exhibited in connection with a stove-grate of Mr. Haywood, Derby.

Model of an Egyptian obelisk, in black marble, the hieroglyphics and Greek inscription copied from the original brought from the Island of Philoe by Belzoni.

Tripod, carved in black marble.

Vases in black marble, copied from Greek terra-cotta vases found near Naples, and brought to England by Lord Western; the figures and ornaments produced by extracting the colouring matter of the marble, without injuring the polish.

Vases, Grecian form, in plain black marble.

Vases, Etruscan form, ornamented with flowers, by extraction of the colour from the black marble; vases, Medicis form, ornamented with various figures.

Tazza of Derbyshire rosewood marble; black marble, with handles; stalactite (Oriental alabaster); and variegated alabaster (gypsum).

Cups, lotus form, with fluted stem.

Chalice, with coronated cover; chalice, plain black, called "Newburgh," and "Wescomb."

Candelabra, ornamented with Thorwaldsen's Night and Morning, scrolls, &c., with fluted shafts on pedestals, and with fluor spar middles.

Candlesticks, various patterns, in black marble, alabaster and fluor spar.

Vase of Derbyshire alabaster on pedestal.

39 WOODLEY, JOHN, *Marble Works, St. Mary's Church, Torquay*—Designer and Manufacturer.

Circular marble table (on pedestal), inlaid with choice and rare specimens of marbles and madrepores, of the different varieties found in Devon.

Twelve-sided polygon marble on pedestal, similarly inlaid.

Oblong table, the centre of which is one slab of a beautiful specimen of red marble, with a border inlaid of madrepores found in the immediate neighbourhood of Torquay.

40 VALLANCE, JOHN, *Matlock Bath, Derbyshire*—Designer and Manufacturer.

Grecian-formed vase of fluor spar, or fluate of lime, commonly called "Blue John." Specimens in the rough state.

Black marble Hebe vases, the marble from Ashford, Derbyshire; tazza vases, known as the Devonshire vases,

on plinth; and copy of the great obelisk, now standing at Karnak, Thebes.

Antique-shaped carved vase, supported by a tripod of dolphins, and square-topped vase, escalloped, and antique shaped, in black marble.

Slab inkstands with and without drawers, in rosewood and black marble. The same, with pen-tray, inlaid with specimens of spars, marbles, &c.

Tazza vases, in black marble, tops inlaid. Black marble cross, inlaid with various specimens. Black marble obelisks and candlesticks, inlaid with various specimens. Model of a Roman bath, rosewood marble.

The marble of the preceding articles is from Ashford, Derbyshire.

Various inlaid articles. Bell-shaped purple fluor-spar vases, on black marble base.

Pair of purple fluor-spar columns, with black marble pedestals; intended for candles, camphine or other lamps, or branches. Purple fluor-spar vases, or bowls, of the tazza and Grecian shape, all on black marble bases.

Oblong black marble table, supported on two elegantly formed pillars, on ornamental stands: top surrounded by an antique border of various spars, marbles, stalactites, &c., enclosing a centre of malachite.

Octagonal black marble table, with gadrooned pillar and triangular plinth, of the same: top inlaid with a wreath of flowers, formed of various rare mineral substances: a passion-flower in the wreath composed of a thousand separate fragments of various kinds of stone; &c. Similar table top inlaid in an antique pattern, with specimens of malachite, lapis lazuli, stalactites, fluor spar, marbles, &c.

[The materials which form the staple of Derbyshire in the department of mineral manufactures, and the usual mode in which they are worked, are illustrated in the above series; and the most remarkable of them, the fluor spar, deserves some notice.

Fluor spar (*Fluoride of Calcium*), is particularly abundant in veins in carboniferous limestone, associated with calc spar barytes, and the ores of lead and zinc. It is found in a crystalline state, transparent, and often in groups of cubic crystals. It is somewhat harder than calc spar; its specific gravity is 3.1 to 3.2; and when exposed to the action of sulphuric acid in the state of fine powder, it gives off fluoric acid vapours which corrode glass. Fluor spar decrepitates on burning charcoal, and before the blow-pipe it loses its lustre, and becomes of milk-white colour. It is often phosphorescent when heated.

Its natural colours are amethystine violet, both pale and dark; bluish green, and wine yellow; but other colours are given artificially by heat and sulphuric acid. It is brittle, but works into ornaments of almost any kind, and often of large size.—D. T. A.]

41 OLIVER ISAAC, 52 *Upper John Street, Fitzroy Square*—Designer.

Imitations of Sienna, Mona, and *rouge royale* marble.

42 HALL, WILLIAM, 5 *Prospect Row, Walworth*—Designer and Producer.

Writing on enamelled slate in imitation of glass.

43 WRIGHT, JAS., *Aberdeen*—Manufacturer.

Polished granite ornamental head-stone.

44 BUCKLEY, G., *Bayswater*—Producer.

Column and two slabs, painted in imitation of Sienna marble.

45 DOLAN, DENIS, 13 *Blackfriars Street, Salford*—Manufacturer.

Scagliola Gothic columns, with arch; illustrating a new method of working, by which any shape can be obtained, such as fluted columns or arches. Stone, iron, or wood columns are covered with great facility.



46 MAGNUS, GEORGE EUGENE, *Pimlico*—Inventor.

Manufactures in slate:—

One end, and a portion of two sides of a bath-room, in enamelled slate; representing various marbles inlaid after the style of Florentine mosaic.

Pair of candelabra, to represent porphyry.

Patent billiard table, with legs and frame enamelled, representing various marbles.

Circular table top, representing black marble, inlaid with lumachelle and jasper. Pedestal, representing porphyry, with black marble, plinth, and jassa.

Chimney-piece representing black marble, with ornamental arched front to stove. Chimney-piece, mosaic foliage, flies, &c., on marble ground, and jasper band.

Arched front to stove, representing various stones; the spandrels representing inlaid porcelain, with enamelled flowers.

Oblong slate table-top, variously marbled. Ink trays.

47 FRANCIS, CHARLES, & SONS, *Nine Elms*—Manufacturers.

Patent screen of Parian cement, representing in the finer qualities various marbles: the centre panel of coarse quality, gilded, and painted in encaustic on the same day that the cement was set. Coarse Parian cement, stuccoed on lath, and painted the same day. Various other specimens.

Medina cement, a concrete block, weighing two tons, mixed with three bushels of cement, the rest shingle; lifted in seven days.

Section of a railway-cutting, the banks lined with a percolating mass of cement concrete, four inches thick, carrying the land springs or rain water to the drains at foot, without injury to the banks.

A cement water-filter, applicable to extensive purposes.

48 THORNHILL, JAMES, *7 Windmill Place, High Street, Camberwell*—Producer.

Two small tables, with tops inlaid with plate glass, in imitation of about 100 kinds of marble; supported by two figures with fruits and flowers, representing Spring and Autumn, finished in bronze; the whole painted without the aid of brushes of any description.

49 LIPSCOMBE, J., & Co., *93 Regent Street*—Manufacturers.

Two drawing-room fountains, in glass and marble.

50 and 34 PLOWS, WILLIAM, *Foss Bridge, York*—Designer and Sculptor.

Statuary marble table, tessellated in the centre with petrified wood (found in Yorkshire), cut transversely; granulated and inlaid with branches of oak with acorns, surrounded by slabs of petrified wood, cut longitudinally, and with granulated flowers and small branches. The pedestal is of Yorkshire marble, girt by a wreath of flowers, in statuary marble upon a Santo Porto ground. The fossil wood is exceedingly hard.

Black marble table, with masonic symbols, found in the crypt of York Minster.

Small figure of David, carved in stone.

Sarcophagus with Gothic canopy; represented in the cut in next column.

51 DUPPA, —, Producer.

An outline drawn on tiles, and afterwards burnt in in the usual way.

52 BROWN, ROBERT, *58 Great Russell Street, Bloomsbury*—Designer and Sculptor.

Sepulchral monument of the decorative period, executed in Caen stone.

53 LANE & LEWIS, *Clifton, near Bristol*—Designers and Executors.

Statue of St. Peter, in canopied niche of Caen stone. On the pedestal are angels holding a scroll; on shafts, supported by their emblems, the four Evangelists, &c.

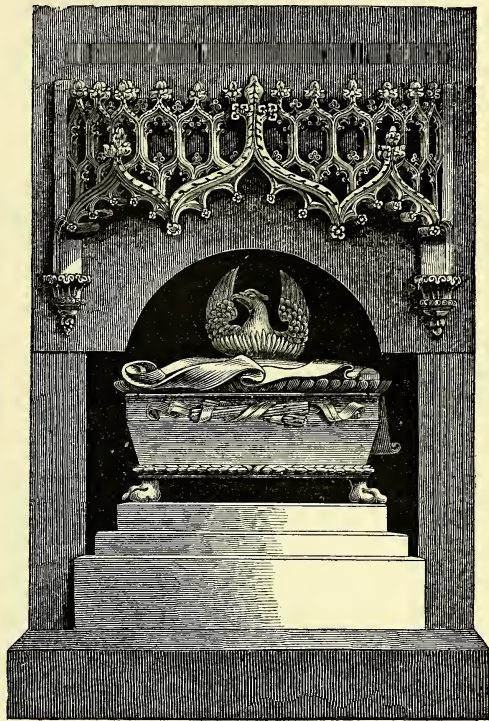

Plows' Sarcophagus.

54 BAKER, ROBERT CHAS., *33 Above Bar, Southampton*—Designer and Modeller.

Original model of a cemetery memorial, with symbolic representations of Faith, Hope, and Charity, in canopied niches, and the carvings of the decorative period of architecture.

55 STUART, W. (Mem. Inst. C. E., Superintendent of H. M. Breakwater), *Plymouth*—Producer.

Polished marble slab on two pedestals, composed of limestone from the breakwater quarries, Plymouth.

56 MOON, G., *Godalming, Surrey*—Designer.

Octagon table, made of several kinds of marble.

57 BELL, J., *25 Buckingham Place, Fitzroy Square*—Designer and Manufacturer.

A pair of obelisks in polished oolite.

58 HOBAN, M., *41 Bollen Street, Dublin*—Manufacturer.

Conglomerate marble table-top. Table-top of red and white Irish marble, from Churchtown, county Cork.

59 RUMLEY, —, *Essex Street, King's Cross*—Manufacturer.

Two small table ornaments, cut in marble.

60 NEWMAN, W. H., *Bathford, near Bath*—Producer.

Bust in Bath freestone: Milton.

61 WHISHAW, FRANCIS, Inventor.

A chess table of novel construction.

63 ROWLANDS, ISAAC, *Llandegai, near Bangor, Wales*—Manufacturer.

Giant ink-stand, sculptured from a block of slate stone, taken out of the Penrhyn quarry, near Bangor.

65 PEARSON, WILLIAM POTTS, *Harrogate, Yorkshire*—
Producer and Designer.

Octagonal stalactite table, composed principally of specimens from the Dropping Well, Knaresborough, and from various portions of the magnesian limestone in the neighbourhood of Knaresborough and Harrogate.

66 PORTER, W. H., *3 Pembroke Road, Dublin*—
Proprietors (in trust),

Specimens of ware, manufactured by Murray and Cowper, of Glasgow, from Irish clays. Ornamental specimens of Irish marble, from Clifden, county Galway, worked by A. M'Donald, a self-taught artist.

67 GRIFFITHS & STRONG, *Eastrov, near Whitby*—
Manufacturers.

Cement stone. Manufactured cement stone.
Model of an agricultural cottage.
Cement tiles for facing houses.

68 ALLEN, C. BRUCE, *12 Lower Porchester Street, Hyde Park*—Designer.

Model of a labourer's cottage, with improvements in construction to lessen expense, adapted for agricultural districts. The walls are of pise, or compressed gravel, strengthened by forming the quoins, windows, door openings, and chimney shafts, of brick, the partitions of hollow brick. The roof is formed of tile, with an improved mode of fixing, and the angles where the roof touches the brickwork are covered and made water-tight by a new form of tile or angle fillet; this angle fillet would be found to be a great improvement on the ordinary means of forming the angles of mortar. The woodwork throughout is rough from the saw, and where in sight is stained, no paint being used. The timbers of the ceilings are rough and stained, and without plaster; the floors of the lower story paved with tiles; the upper floors of wood, rough; the skirtings of wooden fillets fixed to the floor; the plaster of walls running through. The stairs are formed of wooden bearers, and the stair treads of earthenware slabs. The window frames and sashes are of iron. The interior surface of wall is of plaster, impressed with a pattern, and coloured at the same time; thus dispensing with paper, and producing a more pleasing effect; the improved plaster shows light and shade as well as colour. The fire-places are formed of encaustic bricks. The whole is proposed with improvements in warming and ventilation.

69 NICOL & ALLAN, THOMAS & JAMES, *57 Upper Marylebone Street*—Designers & Painters.

Specimens painted on slate, in imitation of marbles, for the decoration of halls, staircases, pillars, &c. Design for a circular table top, painted in imitation of inlaid marbles.

70 LAMBERT, ALEXANDER C., *Conq Abbey, Ireland*—
Proprietor.

Dark green Connemara marble tables and serpentine tables from Ballynahinch quarry, county Galway; standing on large massive pedestals of black Galway marble.

[Ireland is exceedingly rich in some varieties of marble and ornamental stone; and of these the black marbles of Kilkenny and Galway, and the green kinds from Connemara, are well known and much exported. The quarries from which these are obtained are considered capable of almost indefinite extension.—D. T. A.]

71 ROYAL DUBLIN SOCIETY—Producer.

Bust pedestals of white statuary and green Connemara marble, from quarries in Donegal.

72 MONTEAGLE, LORD, *Mount Trenchard, County Limerick, Ireland*—Proprietor.

Specimen of statuary marble, from Dunlavy Quarries, county Donegal: statue of the late Henry Grattan, M.P.

[This specimen of marble is more like that used by the ancients, and obtained from the Isle of Paros, in Greece, than any that is now known. It is remarkable for its tint, but chiefly for the peculiar texture it possesses.—D. T. A.]

73 FRANKLIN, P. L., *Galway, Ireland*—Proprietor.

Bust pedestal of black marble from Lough Corrib, near Galway.

74 M'DONALD & LESLIE, *Aberdeen*—Manufacturers.

Granite vases, pedestals, and a slab for table top.

75 PEARCE, WILLIAM, *Truro*—Manufacturer.

Table of steatite, from the Lizard district, Cornwall. Candelabra of steatites and serpentines, of various colours. Columns of serpentine, from same district.

Pedestals of granite, from Lamorna Cove, near the Land's End; from Constantine, Cornwall; and from Carnsew, Cornwall. Pedestal of porphyry, from Withiel, Cornwall. Columns of black and red granite, from Luxulian, Cornwall; of black and yellow granite, from Lulivery, Cornwall; and of steatite, from the Lizard, Cornwall. A group of these articles is represented in the following engraving.

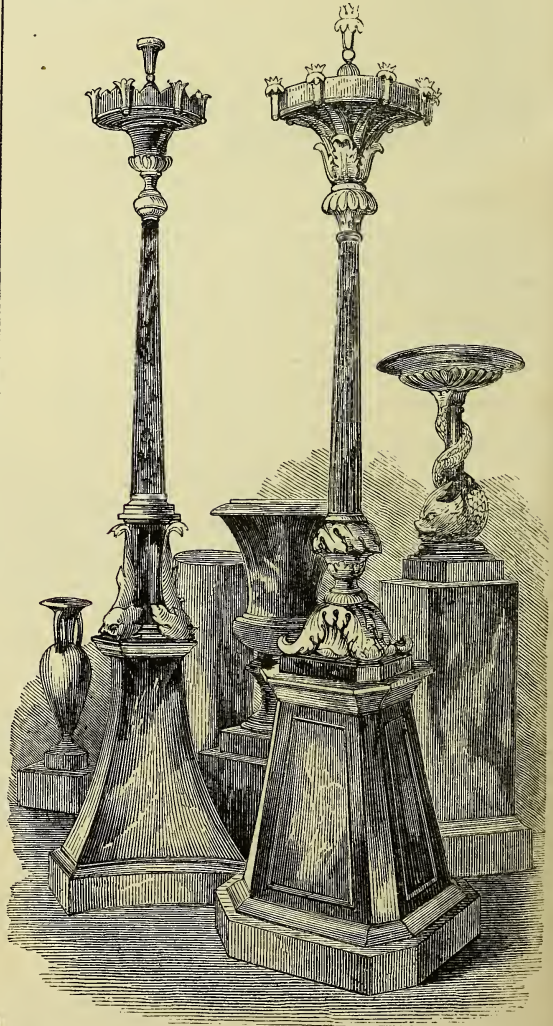

Pearce's Pedestals, Vases, Candelabra, &c.

Chimney-piece of granite, for a hall, from Lamorna Cove, near the Land's End. Side or hall table, of granite, from the same locality.

Timepiece stand of steatite, and tazza and stand, of steatite and serpentine, from the Lizard district, Cornwall.

Vases of serpentine, from the Lizard district. Table of porphyry, from Withiel, Cornwall. Vases of steatites and serpentines, from the Lizard district, of various forms.

[The steatites of the Lizard occur in veins in the serpentine, and are often intermingled with fragments of the containing rock, producing a material of great beauty, well adapted for the manufacture of small ornamental objects. This steatite, according to Klaproth, consists of silica 45, magnesia 24·75, alumina 9·25, iron 1, potash ·75, water 18; containing a larger proportion both of alumina and water than in other localities. Steatite is much softer than serpentine, contains a larger proportion of silica, and is not attacked by muriatic acid.—D. T. A.]

76 OLDFIELD & Co., *Ashford*—Manufacturers.

Column of black marble, from the Arrock Hill quarry, Ashford. Column of laminated rosewood marble, from Nettle-Dale, near Ashford. Column of russet grey marble, from High-Low, near Sheldon. Column of light entrochal marble, from Ricklow-Dale, near Monyash.

77 WOODRUFF, T., *Bakewell*—Manufacturer.

Inlaid marble tables; designed by L. Gruner, Esq., and executed by the exhibitor for H.R.H. Prince Albert. Black marble chess-table, inlaid border, with pedestal. Black marble carved vase. Blue John spar vase, after the antique.

[The Blue John used for various ornamental purposes, is a crystalline fluor spar, abounding in the galena veins, which traverse the carboniferous limestone of Derbyshire and Cheshire. It occurs native, of a rich blue, green, and yellow colour, but is frequently tinted artificially to produce varieties of effect. It is a brittle mineral, rather harder than carbonate of lime, phosphorescent on exposure to heat, and of moderate specific gravity (3·1 to 3·2). It gives off fluoric acid when exposed in powder to the action of sulphuric acid.—D. T. A.]

78 REDFERN, GEORGE, *Ashford, near Bakewell*—Manufacturer.

Marble mosaic table, 4 feet in diameter, chiefly composed of the productions of Derbyshire, from a new design. Black marble vase, copied from the antique.

79 TOMLINSON, JOHN, *Ashford*—Manufacturer.

Oblong mosaic tables of Derbyshire and Staffordshire marbles, mounted on black marble frame and pillars.

Circular mosaic table, star centre, with Derbyshire red marble, black marble, and specimen border, on carved Fonthill foot triangular plinth, on scrolls.

Octagon black marble table, inlaid with birds and flowers, scrap-bands, mounted on octagon pedestal, tray-post plinth, with scrolls.

Octagon Derbyshire black marble table, inlaid with groups of flowers and birds, mounted on black marble pedestal, tray-post plinth, with scrolls.

Inlaid black marble chess-table, mosaic border, mounted on carved Fonthill foot, triangular plinth, on scrolls.

Black marble table, inlaid wreath of flowers, on carved Fonthill foot, &c.

Specimens of mosaic work, portrait of H. M. the Queen, partly composed of foreign marbles.

80 BRIGHT, SELIM, *Buxton, Derbyshire*—Manufacturer.

Black marble vases, exhibited for size, colour, polish, and finish. The handles are carved out of the solid marble; the material is from the Duke of Devonshire's Derbyshire quarries.

Large tripod vase or stand, exhibited for size, colour, and form.

Mosaic octagon table or dish, of Derbyshire workmanship, inlaid with wreath of flowers, butterflies, &c., on a tripod pedestal. The table turns round on a pivot from the foot.

"Devonshire" vase of Derbyshire black marble, handles out of the solid block.

"Portland" vase of Derbyshire black marble, the subject etched with fluoric acid. Black marble chalices.

"Blue John," or amethystine fluor spar chalice, being a specimen of the stone, from Castleton, Derbyshire.

Dish of black marble, unpolished, showing the state of the work prior to the inlaid coloured stones being put in.

81 LOMAS, JOHN, *Bakewell*—Manufacturer.

Pedestals of Derbyshire marbles, intended for busts. Chimney-piece of Derbyshire black and Sienna marbles, inlaid with design in mosaic. Chimney-piece of the Derbyshire rosewood marble, parts of which are sculptured.

[The Derbyshire marbles are entirely derived from the carboniferous limestone, and owe their varieties of colour and condition to various admixtures of carbon and metallic oxides. They are occasionally fossiliferous, being composed of corals, encrinital stems, or shells; sometimes oolitic; sometimes partly or entirely crystalline; and sometimes veined. They are for the most part well adapted for ornamental works. The black marble is abundant, excellent, and much used.—D. T. A.]

82 TURNER, JAMES, *Buxton, Derbyshire*—Manufacturer.

Two jugs, each 56 inches high, made of black marble, found at Ashford, Derbyshire.

83 BIRD, EDWARD, *Matlock Bath, Derbyshire*—Manufacturer and Engraver.

Models in black marble of the obelisk at Heliopolis, and of the Philæ obelisk, the one having the hieroglyphics carved out, and the other the ground etched out with nitric acid.

Black marble slab, with "The Scanty Meal," cut out with steel points.

Black marble card plates, with etched ground, some partly etched and partly cut, others wholly cut with steel tools.

85 ORGAN, J., *Penzance, Cornwall*—Manufacturer.

Baptismal font, chimney-piece, chess-table, columns, obelisks, vases, carved and plain; cabinet of specimens, &c., of serpentine stone from Lizard, Penzance.

[Serpentine—a silicate of magnesia, coloured by iron, manganese, copper, and chromium—occurs in various places in Europe, and has been long worked and much admired as an ornamental stone. The finer kinds, known as ophite, verde, antique, &c., occur chiefly in Italy, and are very hard and of somewhat different appearance from those of the Lizard Point, Cornwall, whence are obtained those here exhibited. The Cornish serpentines are extremely varied in colour, exhibiting veins of red traversing an olive green ground, and are comparatively soft and easy to work. They are obtained in blocks of large size, and are capable of being brought into use as marble, and at prices not much more considerable. A very large block is exhibited outside the west end of the Building, in the south inclosure. Large quantities are now quarried at the Lizard Point.

The serpentine occurs in veins, which also contain copper, and veins of steatite frequently penetrate the serpentine mass.—D. T. A.]

The annexed cuts represent some of these objects.



Organ's Serpentine Obelisk.

86 MINTON, H., & Co., *Stoke-upon-Trent, Staffordshire*
—Manufacturer.

Tiles, terra cotta, and vases, &c., in imitation of Majolica ware. Encaustic and other tiles. Porcelain bath. Stove, in ornamental brick. Friezes, in porcelain.

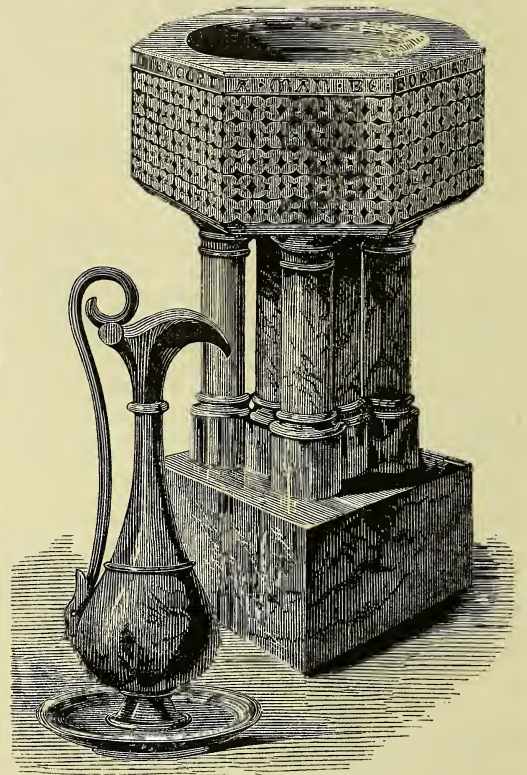

Organ's Font and Vase in Serpentine.

87 THE EARL OF LOVELACE, *East Hornsley Park, Ripley, Surrey*—Producer.

Ornamental bricks and tiles, designed and manufactured at Ockham, in Surrey.

88 SINGER & Co., *Vauxhall Pottery*—Manufacturers.

Specimen of patent mosaic pavement for churches, halls, &c., manufactured of highly vitrified coloured clays, impervious to moisture, and very durable. Stone ware still and head, of an improved material, glazed inside, with worm or condenser. Acid receiver, of improved material. Pan, for boiling acids, of an improved vitrified material. Design in colours of a portion of a patent mosaic pavement lately executed, showing the intersection of four corridors.

[Mr. Singer's patent, obtained in 1839, had reference to a new mode of forming tesserae by cutting, out of thin layers of clay, pieces of the required form, which are afterwards dried and baked in the usual way. The patent also included a new method of uniting the tesserae with cement. This invention is considered to have been a great step towards the revival of the Roman art of making tessellated pavements.—D. T. A.]

89 RUFFORD, FRANCIS, T., *Stourbridge*—Manufacturer and Patentee with J. FINCH, *6 Pickard Street, City Road*.

Bath, adult size, in one piece, made with fire-clay plated with porcelain, and glazed; wash-tub; steam or dolly-tub; assorted bricks, adapted to form waterproof walls, &c. Broken piece from a bath, perforated to show the combination.

The plating of porcelain materials on the fire-clay, by patent process, renders its surface capable of glazing, painting, or gilding.

- 90 RAMSAY, GEORGE HEPPLE, *Derwent Haugh, Newcastle*
—Producer. Agent, A. HUIST, 65 *Mark Lane*.

Carved specimens of cannel coal, including a wine cooler.

- 91 MARGETTS, T. K., and EYLES, H., *Oxford*—
Producers.

Sculptured baptismal font, in Caen stone. Designed by T. K. Margetts, and sculptured by H. Eyles. This font is represented in the annexed engraving.

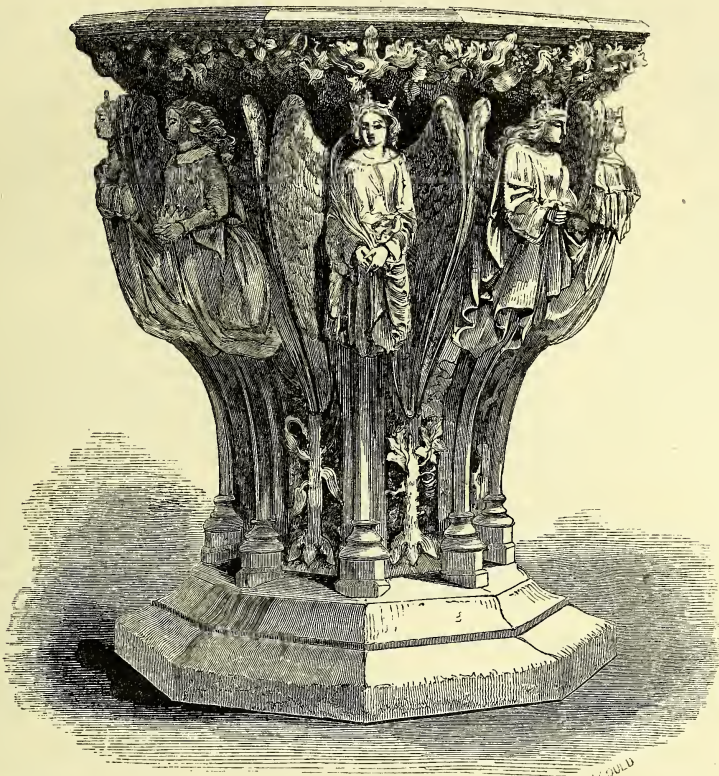

Margetts & Eyles' Sculptured Baptismal Font.

- 92 BLANCHARD, MARK HENRY, *King Edward Street, Westminster Road*—Manufacturer.

Terra-cotta.—An Ionic capital, intended for Clifden House, the seat of the Duke of Sutherland. Designed by C. Barry, Esq.

Gothic pinnacle, executed for a new chapel, Tottenham. Designed by F. Puget, Esq.

Model of the Yarborough testimonial. P. Rolt, Esq.

- 93 FERGUSON, MILLER, & Co., *Heathfield, near Glasgow*—Manufacturers.

Copy of Warwick vase, in fire clay, with pedestal. Exhibition vase, in fire clay, with pedestal. Ornamental flower vase, with pedestal. Specimens of ornamental chimney cans, in fire clay. Variety of small models in fire clay. Specimens of glazed stoneware pipes. (*Outside*.)

[The fire-clays commonly used in the manufacture of such kinds of pottery-ware as are used for outside ornamental work, are nearly pure hydrous silicates of alumina, the best kinds (used for finer work) containing two atoms alumina to three atoms silica, and these approaching more or less nearly to such proportions, but containing an excess of silica, a little oxide of iron, lime, magnesia, and occasionally carbon. They are abundantly found underlying coal seams, in districts where coal is worked.—D. T. A.]

- 94 BOWEN, J., *Bridgwater*—Producer.

Two figures in artificial stone—a Nymph, and Fidelity.

- 95 DOULTON & WATTS, *Lambeth Pottery*—Inventors and Manufacturers.

Articles in stone ware, viz. :—

Condensing worm, capable of resisting the action of the strongest acids.

Ornamental Gothic vase, adapted as a water filter.

Feet warmer, carriage warmer, and breast warmer, with air-tight screw stoppers, of the same material, instead of corks.

Pipes, connected together by air-tight screw joints, of the same material.

Jars, with covers of the same material, ground air-tight with flat surfaces. Invented and manufactured by the exhibitors.

Closest pan, with syphon trap, for sanitary purposes.

Stop cock, of unusually large size, and capable of resisting the action of the strongest acids.

- 96 BELL, J., & Co., *Glasgow*—Manufacturers.

Specimens of vases in terra-cotta.

- 97 RANSOM & PARSONS, *Flint Wharf, Ipswich*—
Inventors and Manufacturers.

Artificial stone in the raw state, and in its various stages of manufacture under the patent process.

Specimens of patent stone in its various applications.

[The artificial stone, referred to above, differs from cements and other artificial stone, in the employment of silica both as the base and combining material. It may be regarded as a collection of particles intimately combined with silicate of soda, by which they are held

together as by a kind of glass. The materials, consisting of sand, clay, fragments of granite, marble, &c., with a little pounded flint, are moulded into form by the aid of a solution of silicate of soda, and are then burnt in a kiln at a red heat. The water is thus driven off, and an insoluble silicate produced, so that the whole becomes a hard compact mass. This stone is much used in various ways, both in a compact, porous, and ornamental state.—D. T. A.]

98 SPROT, MARK & THOMAS, *Garnkirk Works, near Glasgow*—Manufacturers.

Jets d'eau, vases and pedestals, chimney-cans, salt-glazed water-pipes, and fire-bricks, manufactured from fire clay or terra-cotta.

[Terra-cotta is a species of earthen, or rather stone ware, composed of potters' clay, fine sand, and pulverized potsherds; these materials are thoroughly incorporated, and either modelled or cast (in the state of a thin paste) in porous plaster moulds, which absorb the water with which the materials are mixed. After air-drying, the objects are baked in proper kilns at a very high temperature. The term terra-cotta means literally baked clay, and is applied to a large class of antique works of art modelled in clay, including those which have been merely dried in the sun. The art of producing ornamental works in clay was lost until Wedgwood, to whom the ficile art is so greatly indebted, rediscovered methods by which the finest works could be produced; and by employing Flaxman, and other great artists, has left behind him specimens of art, which are eagerly sought after in the present day.—W. D. L. R.]

Specimens of fire-clay, in lump and ground. Model of a flint-glasshouse furnace.

The ornamental vases, pedestals, and fountains are adapted for gardens, pleasure-grounds, &c. The salt-glazed water-pipes are intended as a substitute for iron pipes, for conveying water, &c.

(See Outside, No. 69.)

99 GRANGEMOUTH COAL COMPANY, *Grangemouth, Scotland*—Manufacturers.

One fountain sea-horse and boy. Two large vases and pedestals, newly designed, by Mr. Wornell. Two small vases and pedestals, manufactured from fine fire-clay.

Windguard chimney cans. Salt-glazed pipes of various diameters; piece of pipe broken to show the texture. Fire-bricks of different sizes. Fire-clay, in the raw state, as taken from the pit; fire-clay, ground; fire-clay, burned, but not manufactured. These articles are manufactured by the exhibitors from fire-clay taken from the pit, and used without any admixture of foreign matter.

Pipes, and double junction pipes. Fire-bricks, pressed and not pressed. Kiln plates. Bends and collars. Chimney can plinths. Chimney can. Windguard can. Small vases; pedestals for the same. Stands for lotus and plain vases. Vent lining. Zetland vase and pedestal.

(See Outside, No. 68.)

100 TOMPSON, LEWIS, *Church Terrace, Wisbech*—Designer and Manufacturer.

Moulded architectural bricks.

Equilateral triangular quarterfoil brick window; 12 inch square curved panel brick.

Label knees and stretchers for Gothic windows in brick.

101 LAURIE, WILLIAM, *Downham Market, Norfolk*—Designer and Manufacturer.

Models of monuments denominated "Christian Memorials," and of a tomb of the early part of the fourteenth century.

102 FERNLEY IRON WORKS—Producer.
Sundry articles in terra-cotta.

103 ROBINS, ASPDIN, & COX, *Northfleet, and Great Scotland Yard, Whitehall*—Manufacturer.

Illustrations in Portland cement, to show the strength of this material for making landings, cills, paving, &c. Model of Mazeppa in the same cement.

104 BOWERS, CHALLINOR AND WOOLISCROTT, *Brownhills, Tunstall, Staffordshire*—Manufacturers.

Various architectural decorations manufactured in pottery and imitative of other materials, viz.: Oak carved cornice. Rosewood, Gothic. Elizabethan pattern, lilac. Wash boards, oak. Centre, oak or mahogany. Ornamental bricks. Arabesque work. Cornice shaded two pinks. Grape cornice, marone fruit, green leaves and fawn stalks and gold. Grape, light oak. Grape, bronzed. Pair of groups, natural tinted grape and gold. Pair, white and gold grapes. Pair, green grapes, marone leaves, and fawn stalk and gold. Window cornice. Grape cornice, dark oak stain. Arch brick.

105 JONES, WILLIAM, *Springfield Tile Works, Newcastle-under-Lyme*—Manufacturer.

Model roof material, of plain and ornamental tiles, and ridges of blue, red, and drab (self colours), supported by corner-blocks of the same material, with dressed building bricks. Specimens of the above in full size, with varieties of plain and ornamental ridges. Spouting of the same material.

Paving, foot-bath, stable, barn-floor, flue, and malt-kiln bricks.

Paving quarries—a centre-piece for house-floor, hall, or passage, formed of several radii; red, or red and black, fitted up to a square; the same, blue and buff.

Round, octagon, hexagon, diamond, and square paving-quarries tiles, chimney-pipe, terra-metallic plain and socket-pipes for water-courses and sewerage, &c.

106 BESWICK, R., *Stafford*—Manufacturer.
Bricks of new construction.

107 HICKMAN, RICHARD, & Co., *Stourbridge*—Manufacturers.
Gas retort, made of Stourbridge fire-clay.

108 PULHAM, JAMES, *Waltham Cross, Broxbourn*—Designer and Manufacturer.

Ornamental Gothic building lumps in terra-cotta and cement. Embossed ridge in terra-cotta. Cement and terra cotta ornaments. Inlaid cement paving, and impervious facing tiles.

Model of a mullion window, in cement of a natural stone colour. Air-tight casement, closing against India-rubber.

109 HUNT, CHARLES—Inventor and Manufacturer.
Slate enamelled filter.

110 RAMSAY, GEORGE HEPPLE, *Derwent Haugh, Newcastle*—Inventor.
Fire-clay goods, plain and ornamental, gas retorts.

111 LUFF, JAMES, *Tuddenham, Ipswich*—Manufacturer.

Ornamental chimney shafts for Elizabethan houses, half size. Ornamental red bricks for the same, full size.

Red and white, plain and ornamental bricks, burnt and unburnt.

Ornamental ridge tiles, with cockscombs. Red and white paving tiles, for halls, churches, &c. Malt-kiln tiles, with clay in rough state, as taken from pit.

112 COWEN & Co., *Blaydon Burn, Newcastle-upon-Tyne*—Manufacturers.

Patent fire-clay gas retorts. Fire-bricks required in setting the same. Rough fire-clay, as obtained from the mine.

Cannel coal, from Blaydon Burn colliery, near Newcastle-on-Tyne.

[Gas retorts of Stourbridge clay are now coming into very general use; they generate a larger quantity of gas, and of a purer quality; they have the advantage over iron retorts of greater economy, and more uniform retention of heat. The average duration of an iron retort is twelve months, an earthen retort will last at least double that time.—S. C.]

113 WESTWOOD & MOORE, *Brierley Hill, Stourbridge, Staffordshire*—Manufacturers.

Specimens of glass bottles and improved glazed stone ware.

114 HADDON, J. C., 29 *Bloomsbury Square*—Inventor.

Specimens of rhomboidal bricks.

115 POTTER, ADDISON, *Newcastle-under-Lyne*—Manufacturer.

Ornamental vase and pedestal. Two gas retorts in fine clay. Ornamental stand for fernery, in fine clay, designed by T. O. Small.

116 WORKMAN, JOHN, *Stamford Hill*—Inventor.

Water-proof bricks, for building dwelling-houses, factories, tanks, baths, reservoirs, &c., with samples of other bricks.

117 BROWN, ROBERT, *Surbiton Hill, Kingston, Surrey*—Inventor and Manufacturer.

Grooved ridge tile—the groove admits of the vertical ornaments being made separately.

Ornamental plain tiles, used on buildings in the Gothic style of architecture.

Curved Italian tiles, in various sizes.

118 FORDHAM, JOHN GEORGE, & SON, *Royston, Herts*—Manufacturers.

Improved bricks, from clay found upon the estate of the exhibitors.

119 HARPER & MOORE, *Stourbridge*—Manufacturers.

Glass-house pots, for melting plate and flint glass. Cistern, for plate glass.

Crucibles of various sizes, made of Stourbridge fire-clay.

Stourbridge fire-bricks; and Stourbridge fire-clay retorts; and specimens of Stourbridge fire-clay.

Part of a plate of glass-house pot, which has stood the heat of a melting furnace upwards of five months.

Piece of a potsherd, produced from Stourbridge fire-clay, made into a casting cistern, which has stood the test of fifty-six casts.

Part of a crown glass-house melting pot, which has been submitted to the heat of a furnace upwards of twenty-six weeks.

120 STIRLING, THOMAS, sen., *Bow Bridge Slate Works, Stratford, and 38 New Broad Street, City*—Inventor and Manufacturer.

Patent rapid ascension filter, capable of being constructed as self-supplying, when properly attached to cisterns and to the boilers of kitchen-ranges. Patent Royal Albert filter and wine cooler, so constructed that the water is cooled to any required degree as it passes through the filter, with the same ice that is used for cooling the wine. Patent rapid domestic filters for families, emigrants, &c.; and water filter, adapted for shipping. Economic slate pig-feeding trough, constructed so

as to keep each animal's food distinct. Slate trough for pickling meat, which, by its coolness and impermeability, keeps the brine sweet for a long period.

Fig. 1.



Fig. 2.

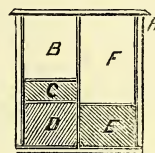
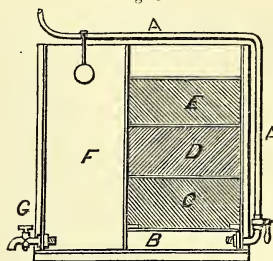

Fig. 3.



Stirling's Patent Slate Filters.

In the above cuts figs. 1 and 2 represent the patent filter and wine cooler externally and in section; H is the cover; B, the reservoir for water to be purified; F, for purified water; C, D, and E, are the beds of filtering material through which the water percolates. Fig. 3 represents a filter to which the supply pipe A is connected. The water first enters the receptacle B, passes upward through C, D, E, and enters F in a purified state, whence it is drawn by the tap G.

Enamelled slate chimney-piece, capable of being made of any size or pattern. Chess table tops, of the same material, in imitation of inlaid marbles, and ornamented. Slate inkstands ornamented and enamelled; slate paste-table and rolling-pin, recommended for coolness, sweetness, and cleanliness; slate milk-pan, cooler than metal, earthenware, or glass. Samples of patent steam fuel.

[The filters above mentioned are constructed on an original plan, and are simple, durable, clean, and cheap. Attempts have been made in Scotland to filter the supply of water for towns on the same principle, and they have been attended with great success. As an instance, may be mentioned the town of Greenock, which is supplied with the Shaws Water, brought in an open canal from a distance of six miles, and filtered in two grand filtering reservoirs, capable of holding 80,000 gallons each. This water at the same time drives two lines of mills, in number 22, possessing a greater quantity of power than all the steam-engines in Glasgow, owing to the extraordinary position of the locality, which is 512 feet above the level of the Clyde, and within a mile of the shore.

These filters being, from the nature of the material, free from decay or corrosion, accomplish the purification of water in an effectual manner. Were the Metropolis furnished with a supply of water from any quarter sufficient for all demands, it could be filtered on the principle exhibited in the above filters, with very little less expense and trouble. For this purpose a vast reservoir, selected at any reasonable distance from town, and capable of containing a supply adequate to the daily wants of the citizens, without the risk of deficiency during any part of the year, might be furnished with the means of purifying the water on the principle of these filters; and thence brought to the metropolis on the principle of gravitation, so as to yield a constant supply of this fluid in a state of the greatest attainable purity.—R. W.]

121 SKINNER & WHALLEY, *Stockton-on-Tees*—Inventors.

Vitreous, white, and coloured marble patent pastes, for mosaics, street designations, house numbers, graveyard memorials, botanical descriptions, garden numbers and borders, ornamental bricks and slabs for rooms, fronts of buildings, baths, washing houses, &c.

The compound is vitreous, and is made of different degrees of density, according to the purpose of its application; in its lowest state of vitrification it is impervious to water, and unaffected by exposure to weather.

The letters and raised ornaments on the slabs being formed of the same substance, and at the same time, cannot be peeled off. The colours are equally durable, being vitrified with the compound.

122 KENT, ALFRED, *Chichester*—Inventor and
Manufacturer.

Model, showing a new system of glazing greenhouses, conservatories, &c. Invented by the exhibitor, and provisionally registered. The chief points of novelty are,—

1. That by the peculiar construction of the lights, and the selection made in the materials to be used, putty and all other adhesive composites are entirely avoided. 2. That the glass can be put in or removed with such facility, that the bars and frame can be painted, the glass cleaned, and the whole effectually repaired at an immense saving upon the old system. 3. That it will not require such frequent repairs as ordinary greenhouses. 4. That in the event of a fracture, it will not be absolutely necessary to wait for the assistance of a glazier to repair the same; the simplicity of the contrivance enabling any one to become

his own glazier. 5. That leakage, a universal complaint in the old system, is here guarded against, by a peculiar grooved bar, which likewise assists in carrying off evaporation, and renders ventilation more complete. 6. That the glass, being moveable, persons can erect greenhouses upon the property of others, and remove the same securely at the expiration of lease or rental terms.

123 PEAKE, THOMAS, *Tileries, Tunstall, Stafford, and at
4 Wharf, City Road Basin*—Manufacturer.

Various specimens of terra-metallic, plain and ornamental roof tiles; garden, drain, oven, coping, kiln and flue tiles.

Specimens of common and paving bricks for various purposes. Clinker and channel bricks. Paving tiles.

Terra-metallic drain or conduit pipes of various shapes and dimensions. Chimney, flue, and top pipes.

Building 4 feet by 3 feet, with glass all round, to exhibit, in miniature, roofing, hip, and ridging; and the application of paving tiles.

Building of the same size, with different kinds of tiles.

Imitation of the "Warwick" vase, in terra-metallic.

Vase with embossed ornament, in terra-metallic.

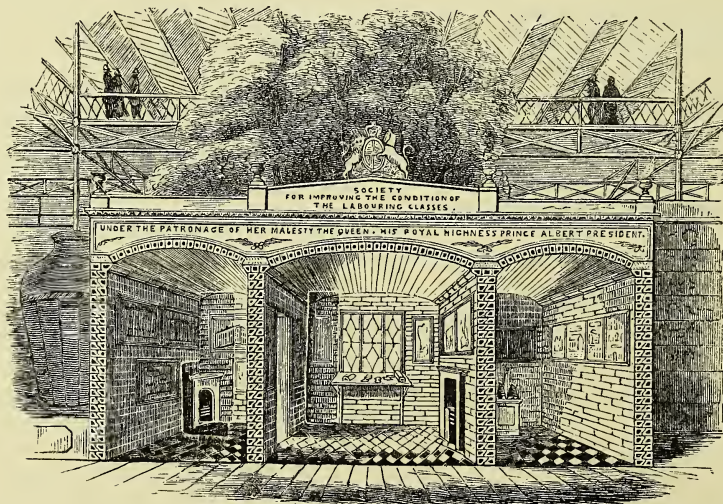
124 SOCIETY FOR IMPROVING the CONDITION of the
LABOURING CLASSES, *21 Exeter Hall, Strand*—
His Royal Highness PRINCE ALBERT, President;
the Earl of SHAFESBURY, Chairman of the Com-
mittee; HENRY ROBERTS, Esq., F.S.A., Honorary
Architect; JOHN WOOD, Esq., Secretary.

Model Structure.

The model structure represented above is intended to illustrate one of the most important branches of the Society's operations, that of the improvement of the dwellings of the labouring classes, and to show the peculiar constructive arrangements and building contrivances adopted by the Society in some of their model houses, particularly that of hollow brickwork, glazed and unglazed, adapted for external and internal walls, chimney-stacks, partitions, floors, and roofs, whereby dryness, warmth, durability, security from fire, and deadening of sound, are obtained, as well as economy of construction to the extent, as compared with the cost of common brickwork, of at least 25 per cent.

The longitudinal bonded wall bricks, invented and patented by Mr. Roberts, the Society's honorary architect, secure the advantage of a perfect bond running longitudinally through the centre of the wall; all headers and

vertical joints passing through it are avoided; internal as well as external strength is obtained, and every facility given for the fixing of floor plates and other timbers; whilst by the parallel longitudinal cavities ample security for dryness is afforded, and great facility presented for ventilation, as well as for the conveyance of artificial heat, and for the transmission of bell-wires, pipes, &c.

The peculiar splayed form of the patent bricks adapts them for use as cornices and mouldings, of which illustrative examples are given in the model structure.

The straw-coloured bricks in the model structure were made at Aylesford, Kent; the red bricks at Ruxley, near Esher; the grey glazed bricks were made at Mr. Singer's, Lambeth, of clay from the north of Devon, chiefly by Clayton's patent brick and tile machine; and the white glazed bricks were made by Mr. Ridgway, at Cauldon Place, the Staffordshire potteries, who also supplied the

fountain hand-basin, with reservoir beneath it, and a glazed earthenware sink, as well as specimens of glazed hollow tiles, suitable for floors and for thin partitions, or wall linings, as well as the model group of four tile-kilns, showing a compact and economical arrangement of an important requisite in the manufacture of hollow bricks, &c.

Patent Bonded Bricks.



Section of a Dwarf Wall.



Quoin Brick.

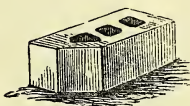

Jamb Brick.

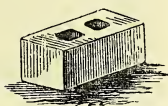

Arch and Partition Bricks.



The tile floors in the centre and right-hand compartments are from Mr. Peake, Tunstall, Staffordshire, or 4 Wharf, City Road Basin; those in the left, from Messrs. H. and R. Haywood, Burslem, Staffordshire, and No. 15 South Wharf, Paddington.

The prize cottage range and fender, set in the centre compartment, and the bedroom grate, with fire-brick back and cast-iron chimney-piece, in the left-hand compartment, are both from Mr. W. Nicholson, of Newark.

Various specimens of ironmongery suitable for cottages, including the window-light of zinc, with iron frame and stay fastening; also various descriptions of ventilators, adapted for use with common as well as with hollow brickwork, from Hart and Sons, Wych Street, Strand.

The model placed in the central compartment exhibits H.R.H. Prince Albert's model houses for four families, erected at the Hyde Park Barracks, opposite the Exhibition Building. The other model in the left-hand compartment is that of the model houses for 48 families, built by the Society, in Streatham Street, Bloomsbury.

The coloured views, with plans beneath them, exhibit the various model houses erected by the Society in London.

The lithographed working drawings are the designs of the Society's Honorary Architect, published by the Society, with a view to promote an improvement in the dwellings of the working classes in towns, as well as in agricultural, manufacturing, and mining districts. They may be obtained at the Society's office, 21 Exeter Hall, together with specifications, and detailed bills of quantities of materials; where also may be had Mr. Roberts's Essay on the Dwellings of the Labouring Classes, as well as cards to view the Society's model houses, and detailed particulars in reference to hollow bricks, &c.

[The Society, since it was reconstructed in 1844, under its present designation, has embraced a much more extensive field of operation than that of the Labourers' Friend Society then incorporated with it—a considerable portion of its energies being directed to the important object of the improvement of the dwellings of the labouring classes, in which difficult department it was the first Society to exhibit practical examples, and to commence a series of model buildings adapted to the various circumstances of those classes.

Four piles of new buildings have been erected by the Society, viz :—

1st. The model buildings, Bagnigge Wells, which will lodge 23 families and 30 aged females.

2nd. The lodging house in George Street, St. Giles's, for 104 single men.

3rd. The model houses in Streatham Street, Bloomsbury, for 48 families.

4th. The Thanksgiving model buildings, Portpool Lane, Gray's Inn Lane, erected in commemoration of the removal of the cholera, 1849, for 20 families and 128 single women, together with a spacious public washhouse, and a depository for hucksters' goods.

On the above buildings, including the cost of land, upwards of 30,000*l.* has been expended. The Society has also established, in Charles Street, Drury Lane, a renovated lodging house for 82 single men, and in Hatton Garden, a lodging house for 57 single women, on which about 2,000*l.* has been expended.

The result of these experiments, which shows a sufficiently remunerative return on the outlay of capital, has been submitted to the public, with a view to stimulate and guide in the general adoption of sound and practical efforts for effecting a reformation, the importance and necessity of which are generally admitted.

The amount contributed by the public towards the cost of these several model houses, has in no case much exceeded one-half the outlay. The clear revenue from rent, after the gradual payment of the sum borrowed for the completion of the buildings, will be devoted to carrying on the general objects of the Society, as defined by the Charter of Incorporation.

The building operations of the Society, have from the novelty and experimental character, been attended with more than ordinary difficulties. In thus breaking up new ground and acting as pioneers, the Committee instead of confining themselves to the comparatively easy task of teaching by precept, has laboured to illustrate and recommend their plans for improving the dwellings of the people by actual examples, which can be easily understood and imitated.]

125 GREEN, S., & Co., *Imperial Potteries, Lambeth*—Manufacturers.

Chemical pottery wares. Complete apparatus for distillation and condensation. Manufactured in terra-cotta chemical stoneware to stand great heat, and lined with acid-proof glaze.

Condensing taper cylindrical tubes, to show the means of connection by luting. Condensing tubes, spherically ground connection, requiring no luting. The cut (p. 776) represents the vast size of the chemical pottery wares.

Spherically stoppered air-tight jar, for extracts, &c., in salt-glazed stone ware. Set of Woolf's apparatus complete, with patent air-tight connexions. Test-tubes, syphons, retorts, crucibles, &c.

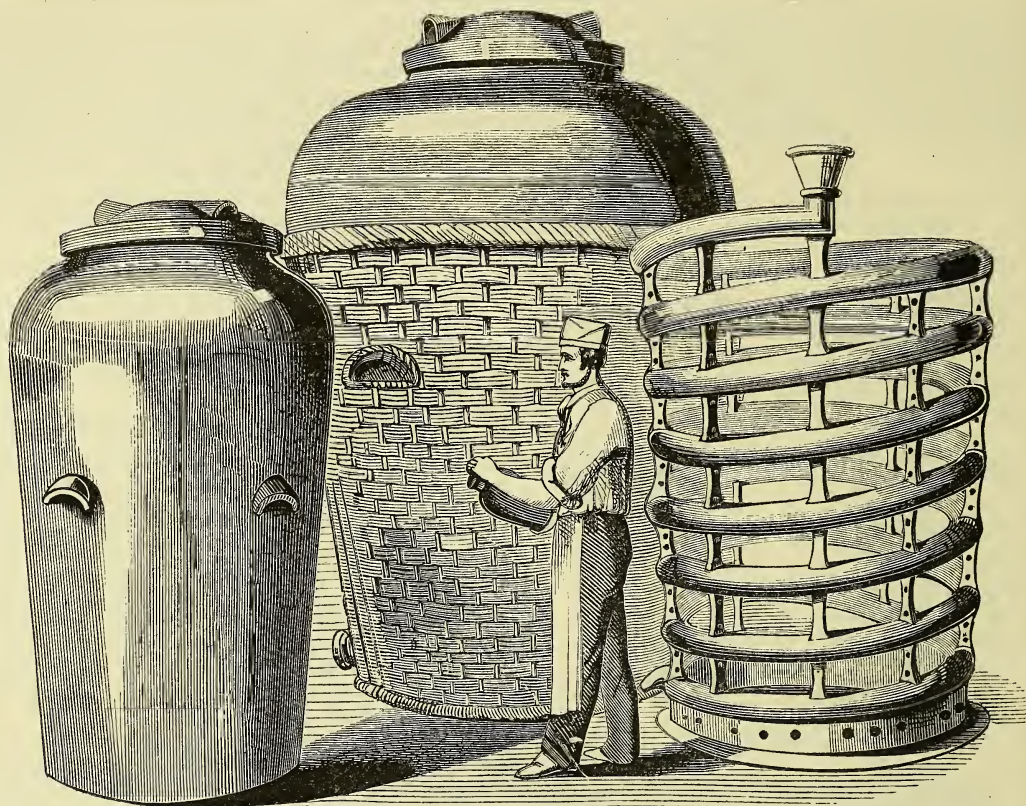

Green & Co.'s Chemical Pottery Wares.

Vessel of the capacity of 400 gallons, manufactured in vitreous salt-glazed stone earthenware, with patent spherically stoppered air-tight lid, and anti-corrosive cock.

Condenser or refrigerator, for distillation or cooling.

Another condenser, with the tubes so arranged as to be capable of being cleansed.

Spirit bottles cased in wicker.

(See Outside, North Side.)

126 KEY, EDWARD STIRGES, *Bale, Dereham, Norfolk*—Inventor.

White brick Gothic window frame, with small mullion bricks. Red brick, light glazed girt, window frame with opening iron casement, on a new principle. Provisionally registered.

New glazed valley tiles, manufactured by W. Colman, Swanton Novers, Norfolk.

127 HAYWOOD, H. & R., *Brownhill's Tilerics, near Burslem, and 15 South Wharf, Paddington*—Manufacturers.

Superior metallic clay, dug from mines near Burslem.

Specimens of the clay, tempered and prepared for working, with samples of the articles manufactured from it, namely:—Tubular and heart-shaped pipes, plain, socket; conical and jointed of various sizes, with bends. Elbows, junctions, syphon traps, sough grids. Channel, square, and arch bricks, and Lowe's patent stench-trap grids, &c. Ornamental chimney shafts.

Plain and ornamental covering, hip, valley, ridge, and floor tiles, in great variety of patterns. Building, wall, coping, and stable bricks. Malt kiln tiles, skirting, and garden edging. Ornamental pavements; stable mangers; and fire-proof flue linings.

128 AMBROSE, JOHN, *Copford, near Colchester*—Manufacturer.

Gothic chimneys of red and white bricks. Specimens of white bricks and unmanufactured clay.

130 SEALY, JOHN, *Bridgwater, Somersetshire*—Inventor and Manufacturer.

Patent double and treble channelled roofing tiles.

Patent single channelled flat, or Roman roofing tiles.

Ridge and hip roofing tiles. Valley roofing tiles. Corn and malt kiln tiles. Bakers' oven tiles and bricks. Paving or flooring tiles.

Bridgewater scouring bricks, commonly called Bath bricks.

Glass jars, containing the waters of the River Parret; the scouring, or Bath bricks, are formed from the deposit of these waters. Bridgewater clays and slime.

131 BRANNAM, THOMAS, *Barnstaple, Devon*—Inventor.

Oven, generally used in Devonshire for baking bread and meat.

Syphon-trap, an improved invention for water-closets.

Gothic crease, upon an improved plan.

Earthenware jugs, pitcher, and milk-pan, all made of Devonshire clay.

[This clay is raised in the parish of Fremington, near Barnstaple, Devon, on the property of Stephen Crocker, Esq. The celebrated Devonshire clotted cream is produced by scalding milk in the milk-pan here exhibited.]

132 JEPSON, W., *Edensor, Derbyshire*—Producer.

A Blue John vase, of extraordinary dimensions.

140 H. R. H. PRINCE ALBERT.—Exhibitor.

A block of parrot coal from West Wemyss Colliery, Kirkaldy, Fifeshire, partly polished; and garden seat, designed by L. Gruner, Esq., and executed in Fifeshire, by Thomas Williams Waun, of parrot or cannel coal, from the estate of Rear-Admiral Wemyss.

141 EMERY, JOHN, *North Street, Westminster*—
Producer.

Model of a Gothic door in plaster.

142 CABANIC PATENT, 29 *Marylebone Street, Regent Street*—Producer.
Decorations in various devices.

144 WHITE, J. B. & SONS, 14 *Earl Street, Blackfriars*—
Manufacturers.

Wall decorations in plaster and cement in various devices; also a chimney-piece in Keene's cement.

145 PYM, JOHN, 2 *Moorgate Street*.
An improved building material.



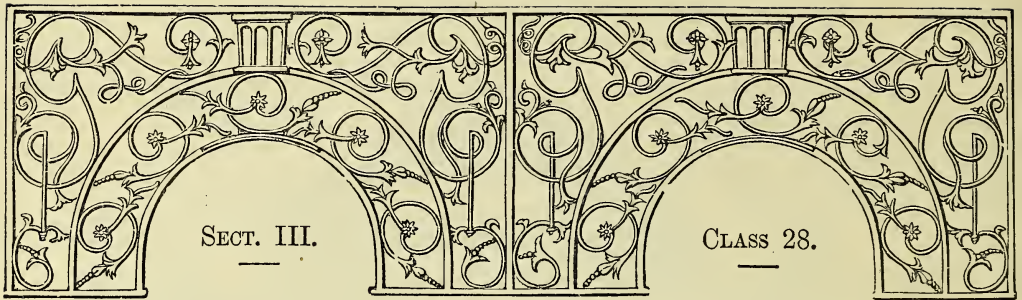

MANUFACTURES FROM ANIMAL AND VEGETABLE SUBSTANCES, NOT BEING WOVEN OR FELTED.

INTRODUCTION.

THE limits of this Class appear to confine the number of Exhibitors in it to a smaller number than in several other Classes. Many objects which are included under the general term Manufactures from Vegetable and Animal Substances have been already disposed of and arranged under other departments. That which is considered specially to distinguish those which appear in this Class is the fact of their not being either woven or felted articles. Considering, however, the great variety of articles which fall naturally under this distinction, it may appear singular that the Class is a small one numerically. But it is not to be forgotten that the manufacturer and vender, the latter appearing in the capacity of proprietor of these articles, has only a limited demand for them, and not unfrequently combines the manufacture or the sale of several in one establishment. To this, however, the exceptions of caoutchouc and gutta percha manufactures require to be made. Many of these articles, also, are not to be regarded as first requisites in the social economy—they are not of absolute requirement, nor consequently of universal demand.

The Class is thus subdivided:—The Sub-Class—A. Includes Manufactures from Caoutchouc, as, 1. Impermeable boots, life-preservers, hydrostatic beds, air and water cushions, bags, &c., and prepared water-proof and air-proof textures of every description; 2. Elastic articles, as carriage-springs, buffers, bottles, bands, washers, valves, webbing, stoppers, &c.; and, 3. Articles in caoutchouc, moulded, embossed, coloured, and printed, such as maps, bottles, cocks and taps, plugs, &c; B. Comprehends the Manufactures from Gutta Percha for water-proofing purposes and agricultural uses—for maritime purposes, as trumpets, life-buoys, &c.,—for decorative uses, as picture-frames, mouldings, &c.,—for surgical and philosophical uses generally, and for domestic and miscellaneous uses; C. Includes Manufactures from ivory, tortoiseshell, shells, bone, hair, bristles, and vegetable ivory; D. General Manufactures from wood, not being furniture, as turnery, carving, coopers' work, basket-work, &c.; E. Manufactures from straw, grass, and other similar materials; F. Miscellaneous Manufactures from animal and vegetable substances.

The articles belonging to this Class are placed in the North Gallery, near the Transept. They are there arranged in cases, and otherwise, and present a convenient opportunity of studying the variety of purposes to which these articles have been made subservient.

The remarkable substances, caoutchouc and gutta percha, which form so prominent a feature in this Class, are represented by a considerable number of Exhibitors, regard being had to the recency of the commercial introduction of these vegetable products. The history of caoutchouc dates considerably further back than that of gutta percha; but its application to the purposes of life is still fresh, and daily extending. It has become an article of great commercial importance. The quantity annually received by this country from abroad was, twenty years ago, only about 50,000 pounds. In ten years from that time the imports reached the annual average of between 700,000 and 800,000 pounds, and they are now considerably more than this. From a single port in South America, nearly 4,000 cwts. are annually exported to England. The commercial supplies of this valuable substance are derived principally from *Siphonia elastica*, *Ficus elastica*, and *Urceola elastica*. The two latter appear to be the principal sources of the caoutchouc received from the Indian Archipelago. The former, *Siphonia elastica*, yields the major part of the vast supply received by us from South America. This tree extends over a vast district in Central America, and the caoutchouc, obtained by incision of its milk-bearing bark, is considered to be the best adapted for manufacturing purposes. The caoutchouc of the East is rapidly rising into importance, and it being known that over thousands of square miles in Assam this tree is abundant, doubtless the imports will greatly increase as the sources of supply are more fully developed.

The discovery of the property called vulcanization, of which caoutchouc is capable, when properly treated by means of sulphur—a fact due to the experiments of Mr. Thomas Hancock—has rendered it more than doubly valuable for every purpose to which this substance is applicable. Its strength and elasticity are increased to a degree almost incredible by this process; and the objections of hardening in the cold, and of too ready solution in unctuous substances, are thus wholly removed. A variety of illustrations of caoutchouc in its natural, and in its manufactured and converted states, are exhibited in this Class. Among other applications of vulcanized caoutchouc, one which will attract much interest is the discovery of what are called "cumulators." These consist of a number of bands of this material, which are one by one tightened until the combined power of the whole series acts upon the desired point, and, exercising their accumulated force, the power is acquired which may be applied to any desired end. A child may thus lift a ton in weight. The same power has been applied to projectile purposes.

Gutta percha is yet new to commerce and the manufacturer; but the enormous extension of its application to various purposes of use and ornament appears to promise a still greater degree of commercial pre-eminence to it than to the former substance. A subsequent note makes allusion to its introduction into this country, probably even at a period anterior to that of caoutchouc. Its recent discovery by Dr. D'Almeida and Dr. W. Montgomerie is, however, a more readily attested fact in its history. A few years since only a small piece of gutta percha, weighing a few ounces, was possessed by one individual in this country. At present, extensive factories exist, in which hundreds of artisans, and powerful engines and machinery, are almost incessantly employed and in work, supplying the daily increasing demand for articles made of it; those exhibited by different persons will convey a good idea of the variety of purposes to which this material adapts itself, and for which it exhibits properties so convenient as to render it a vast boon to art, to domestic comfort, and even to physical philosophy.

Among the miscellaneous materials employed, vegetable ivory is rising into importance. This substance, yielded by a palm, *Phytelephas macrocarpa*, was, until recently, only a botanical curiosity. Its substitution for ivory is constantly proceeding; but, from the small size of the fruit, it can never come into competition with it for articles of a large size, where continuity of structure is essential. Various articles made from it are exhibited, with specimens of the material itself.

The other objects comprehended by the Class, and adequately represented in the Exhibition, scarcely appear to require special notice in this place. Having reference to specific purposes, and those chiefly of daily and domestic use, they will receive the attention they claim on inspection in the Building.—R. E.

3 HASTINGS, S., *Limerick, Ireland*—Manufacturer.

Brushes, for shoes, horses, stoves, grates, &c., made of various kinds of material.

7 JONES, DAVID, *Hay, Wales*—Designer and Manufacturer.

Welsh rustic picture frame, made with the natural excrescences of the apple-tree.

8 WALLIS, SAMUEL, *Halifax, Yorkshire*—Designer and Carver.

Ornamental carvings in mahogany for a sideboard; design, the vine and fig-tree.

9 SCALING, W., *37 George Street, Edinburgh*—Manufacturer.

Willow flower-pot stand, serving the same purpose as if made of iron or wire; it is lighter and more graceful in appearance, and exhibits a new combination of iron and willow, by which the latter can be made available for many useful and ornamental purposes.

10 WIPPELL, JOSEPH, jun., *219 High Street, Exeter*—Designer.

Open octagonal alms-basin, of walnut wood, lined with silk velvet, with pateras in the side mouldings; the whole forming the capital of a Gothic pillar. This alms-basin is represented in the following cut.



Wippell's Octagonal Alms-basin.

Circular alms-basin, same material, &c., with moveable trefoil cover. Octagonal alms-basin, with circular opening in the moveable cover. Another with battlements at the edge, with a fixed cover of tracery, and a locked opening at the back for removing the amount collected.

Improved sacramental bread-cutter; which cuts the bread three parts through; the slice will break into 25 cubical pieces.

12 RAMSEY, JAMES, *Berwick-on-Tweed*—Inventor and Manufacturer.

Bee-hive, with moveable bottom and screw, whereby the hive can be enlarged. Bee-hive, enlarged, with a moveable crown within the hive.

Bee-hive in the form of a temple, with Gothic door, spire, and moveable crown, exhibiting a glass crown, in which the operations of the bees can be inspected.

Bee-hive, ornamented with coloured willow and straw, bearing the initials of Her Majesty with the Crown wrought in willow.

13 CUNDALL & ADDY, *21 Old Bond Street*—Producers.

Bread platter and knife.

14 CHATWIN, H., *30 Darwin Street, Birmingham*—Manufacturer.

Work-boxes, caddies, &c., in tortoiseshell, mother-of-pearl, &c.

15 JOHNSON, PETER, *Wigan*—Manufacturer.

A quantity of fancy articles turned in ivory, wood, and cannel coal.

16 FARRAR, B., & SON, *Chapel Lane, Bradford*—Manufacturers.

Twine made from hemp, flax, and cotton.

18 CRUMMACK, E., *York*—Proprietor and Manufacturer.

Tortoiseshell, ivory, and horn dressing-combs, made by hand.

20 MCCLINTOCK, GEORGE, *York*—Manufacturer and Designer.

Chain cut from a solid block of wood.

21 JACKSON, THOMAS, *3 Pinstone Street, Sheffield*—Manufacturer.

Stiff brushes. Polishing brushes, in various sizes, used by table knife and fork manufacturers, spring-knife and powder-flask manufacturers, cutlers, silversmiths, file-makers, &c.

Soft brushes. Polishing brushes, used by silversmiths for colouring. Goats' hair finishing brushes, for silver goods. Goats' hair-end brushes, large and middle.

Stiff-end brush, large and middle. Scratch-brush, for dead silver work. Scratch-end brush, for silver work. Seared end brush, and set end brush, for cream-jugs. File-brush. One joint-brush. Boil-brush.

22 SMITH, JOSEPH, 79 *Sidney Street, Sheffield*—
Manufacturer.

Mortice-lock, and knobs for doors, of various patterns, turned in ivory and fancy woods. Drawer-knobs, of various patterns, in fancy woods, ebony, zebra, and japanned. Bird's-eye maple-wood finger-plate. Ivory dado and bird's-eye maple bell-lever. Ivory keyhole escutcheon. Carved bread-platters. Beer-machine handles. Mahogany cornice-pole ring.

28 MAUNDER, JOHN, *Lumceston, Cornwall*—
Manufacturer.

Small wood table, with miniature dessert set, turned in ivory.

29 DOW, ANDREW, 6 *Childwall Street, Liverpool*—
Designer and Manufacturer.

Veneered brushes for plate, watches, and jewellery. Plate-brushes filled with horsehair. Jewellery and watch brushes, with horse, foreign goat, and human hair drawn into small holes.

30 SCHOOL OF INDUSTRY FOR THE BLIND, *Bristol*—
Manufacturers.

Worsted hearth-rugs of different patterns and qualities. Worsted and cocoa-nut fibre door-mats. Osier nursery chair; child's cradle; baskets for linen, for carrying rolls of music, and for holding loose papers; fire-screens for hand and back of chair; nursery basket; oblong, round, and oval ladies' work-baskets; dish-mat. Made entirely by blind persons.

34 COOK, JOSEPH, *Bradford Street, Walsall*—
Manufacturer.

A variety of brushes.

35 LEE, FRANCIS, *Shipdham, Norfolk*—Producer.

Carved oak lectern, of the flamboyant, or late decorated style of architecture.

36 CRESPIN, E., *Cheshunt, Hertfordshire*—
Producer.

Model carvings of church ornaments, &c.

38 BEVINGTONS & MORRIS, 67 *King William Street, City*—
Manufacturers.

Cocoa-nut fibre matting and mats; cocoa, manilla hemp, and worsted door-mats, of various kinds.

39 TRELOAR, T., 42 *Ludgate Hill*—Manufacturer.

Samples of mattings made of cocoa-nut fibre (patterns provisionally registered). The same, with an admixture of Manilla hemp. Door-mats of cocoa-nut fibre. Hearth-rug of the same. Mattress of patent curled cocoa-nut fibre. Brushes and brooms, various, all filled with the fibre. Specimens of cocoa-nut fibre plait. Bonnet and hat made of the plait. Specimen of seating or fine cloth of cocoa-nut fibre.

40 WILDEY, WM., & Co., 7 *Holland Street, Blackfriars' Road, Southwark*—Patentees & Manufacturers.

Specimens of manufactures from the fibre of the outer husk of the cocoa-nut, consisting of floor-mattings, plain and coloured; door-mats; netting for sheep-folds and other uses; hassocks; nose-bags for horses. Cocoa-nut husk; fibre from the same; fibre prepared for brushes, substitute for bristles; fibre curled, substitute for horse hair mattresses; fibre dyed; yarn spun from fibre; cordage, from fibre; curling and spinning by machinery, and patent preparation of fibre from the husk.

The use of cocoa-nut fibre for bedding presents many advantages; it does not become knotty or hard, it does not harbour vermin, and is not affected by variation of

climate; it is also recommended by the great cheapness at which it can be produced.

[The value of the cocoa-nut palm to the inhabitants of the districts in which it is found native can scarcely be exaggerated. The edible fruit is important as an article of food, and the husk in which it is enclosed supplies valuable material for the manufacture of cordage, matting, &c. Others of the palms, and other parts of this palm (*Cocos nucifera*), furnish an inexhaustible list of useful products. Thread, needles, bristles, brushes, pens, arrows, coarse cloth, and a variety of other articles, are obtained from the stem, leaf-stalks, and leaves of trees belonging to this natural family, the members of which were called by Linnæus the princes of the vegetable world.—R. E.]

41 KING, JOHN, 49 *Tufton Street, Westminster*—
Designer, Inventor, and Manufacturer.

Straw work baskets in colours. Chandelier manufactured of coloured straw. Intended as a specimen of workmanship in straw, and also to show that straw-work can be applied to various ornamental purposes.

42 ROBINSON, VINCENT, & Co., 38 *Welbeck Street, Cavendish Square*—Importers & Inventors.

Specimen of China matting, stained in pattern (by a new process); for drawing and dining rooms, boudoirs, libraries, &c.

[China matting is said to be made from plants of the palm and rush tribes.—E. F.]

43 ARMSTRONG, JOHN, 9 *Chad's Place, Gray's Inn Road*—Designer and Manufacturer.

Summer and winter carriage rugs. Drawing-room and bed-room mats. Carriage rugs and bed-room mat of worsted, with hemp and jute. Drawing-room mat of the best worsted, with hemp, jute, and cocoa fibre.

45 KAIN, JOHN FRANCIS, 27 *Brownlow Road, Dalston*—
Inventor and Manufacturer.

Full-sized bird cage, made principally of ivory, and without wire.

47 TAYLOR, BENJAMIN, 169 *St. John Street Road, Clerkenwell*—Manufacturer.

An Oriental tower, with minarets composed of upwards of 1,000 pieces, manufactured out of the corozo, or vegetable ivory nut, the produce of New Grenada. This tower is represented in the cut (p. 781).

Vegetable ivory vases. Specimens of the vegetable ivory nut, shown in section and in their natural state. The cut (p. 781) represents these specimens. Sundry fancy articles manufactured out of the vegetable ivory nut. Ladies' table cushion, with fittings complete, in vegetable ivory.

[The ivory nut is the seed of a dwarf palm tree, producing its fruits in large round heads. The part used by turners is the hard albumen, or the part which answers to what is called the flesh of the cocoa-nut. It is as durable and nearly as hard as the ivory of the elephant, whence botanists call it *phytelephas*, or elephant tree.—J. L.]

48 FENTUM, MARTIN, 8 *Hemmings Row, Charing Cross*—
Manufacturer.

Improved ivory chessmen and chess-board.

49 BROWN, HENRY, 187 *Whitechapel Road*—Inventor.
"British ivory" (not a composition).

51 COATE, JAMES, & Co., 5 *Brewer Street, Golden Square, St. James's*—Designers and Manufacturers.

Concave tooth brush, graduated to fit large or small teeth, and bevelled.

Penetrating hair brush, drilled, elliptic. Model for carved ivory hair brushes, with new design.

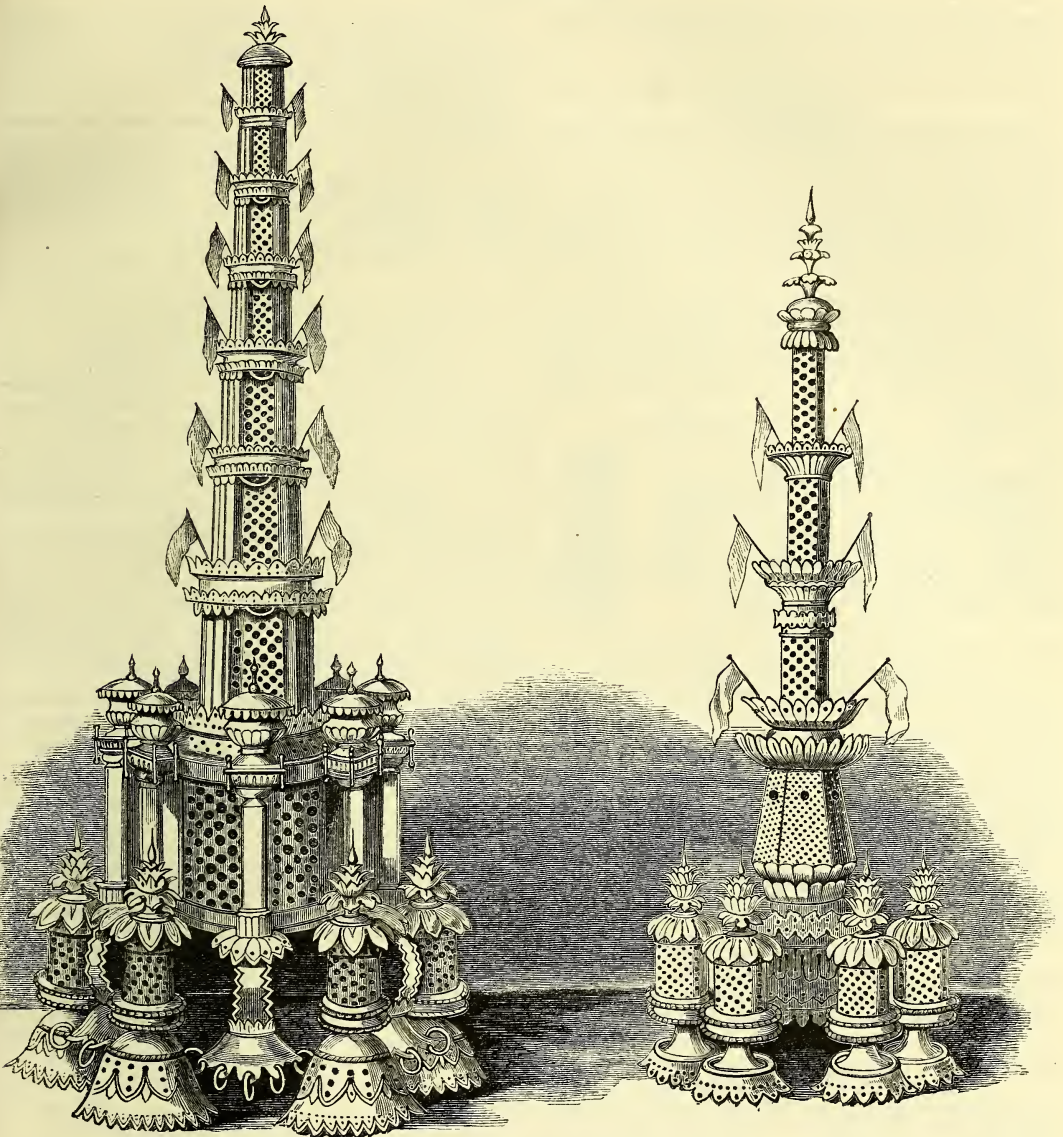

Taylor's Oriental Towers in Vegetable Ivory.

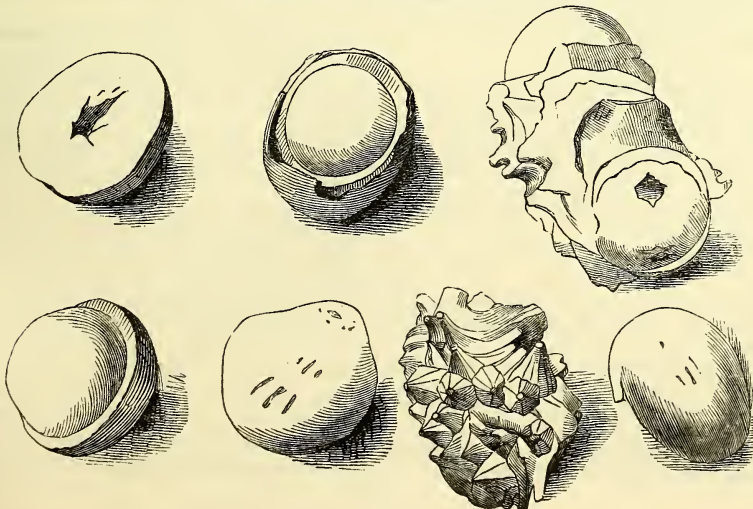

Taylor's Specimens of the Vegetable Ivory Nut.

53 TITTERTON, G., 70 *Margaret Street, Cavendish Square*.
A case of brushes.

55 GOSNELL & Co., 12 *Three Kings Court, Lombard Street*
—Manufacturers.

Extracts, perfumes, and perfumery. Fancy toilet soaps of various kinds. Fancy brushes and combs.

55A SMITH, AUG., 8 and 9 *Osborn Street, Whitechapel*—
Inventor and Manufacturer.

Painting brushes, flat, and fit for heavy or fine descriptions of work.

58 RIGBY, EDWARD ROBERT, 80 *Gracechurch Street*—
Patentee and Manufacturers.

Specimen of brushes manufactured from quills. The fibre is rendered applicable for all purposes in which bristles have been used, and is considered equally useful and durable.—Patented.

60 GREEN, —, *Webber Street, Blackfriars Road*.

Specimens of workmanship in hair.

61 CHILD, WILLIAM HENRY, 21 *Providence Row, Finsbury Square*—
Producer.

Improved stock brush, bound with copper. Flexible flesh brushes, made in wood, upon an improved system. Hair brushes. Improved nut-crackers.

62 TRUEFITT, H. P., 20 and 21 *Burlington Arcade, and 114 Piccadilly*—Inventor and Manufacturer.

Wigs, head-dresses, hair dyes, brushes, combs, &c.

64 ROSS & SONS, 119 & 120 *Bishopsgate Street Within*—
Inventor and Manufacturers.

Ornamental hair. Head-dresses. Peruke of grey hair, parts of it dyed of different colours. Hair lengthened artificially. Brushes, and various articles of ornamental perfumery.

65 TRUEFITT, WALTER, 1 *New Bond Street*—Manufacturer.

Carved ivory brushes and comb. Tortoiseshell combs. Head-dresses of natural hair.

67 SLAPE, GEORGE, 7 *Brook Street, New Road*—
Designer and Manufacturer.

Fancy feather brush, carved in English walnut.

68 NASH, THOMAS, jun., 19 *Swan Street, Dover Road, Southwark*—Inventor and Manufacturer.

Registered copper-bound painter's brushes, having a single copper band tightly pressed round the bristles, and rivetted through to the peg or handle, thus firmly securing the bristles and handle. The band is flattened into an oval form, by which the brush is spread so as to give it the most efficient working form.

70 TALLERMAN, REBECCA, & SON, 20 *White Lion Street, Norton Folgate*—Inventors and Manufacturers.

Waterproof Cachmere, adapted for ladies and children's boots and shoes, and other articles, with manufactured specimens. Black silk and satin side-laced boots. Maroon-coloured velvet boots. Specimens of black silk, satin, and velvet waterproofed; and of black silk, satin, and velvet. Patented.

Ventilating waterproof boot.

72 HODGES, RICHARD EDWARD, 44 *Southampton Row, Russell Square*—Inventor, Manufacturer, and Patentee.

Patent improvements in mechanical purchases, called cumululators. Highly elastic tackle, made of India rubber, is substituted for, or employed in combination with the rigid kind ordinarily employed, and applied so that a single man may bring any required amount of mechanical force to bear against the body to be removed.

Travellers' staffs. One of these staffs serves as a hand-carriage to convey bundles or packages. By increasing the length and strength, great weights may be carried on this simple arrangement.

Patent improvements in projectiles—consisting in the application of India rubber to guns, bows, and other projectiles, whereby harpoons, arrows, spears, balls, shot &c., may be thrown with great force, and to great distances. India-rubber guns. Bows with arrows. Arrow projector. Shot and ball projector. Sheath for projecting various missiles.

73 SANDERS, JOHN, 11 *Fore Street, Cripplegate*—
Producer.

India-rubber waterproof umbrella tent.

75 WANSBOROUGH, JAMES, 52 *Little Britain*—
Inventor, Patentee, and Manufacturer.

A waterproof cloth, in imitation of velvet, each side can be made of a different colour; suited for upholstery, curtain-hangings, binding of books, caps, hats, &c.

76 MACKINTOSH, CHARLES, & Co., 73 *Aldermanbury, and Cambridge Street, Manchester*—Importers, Manufacturers, and Patentees.

Specimens of natural caoutchouc, as imported; of India-rubber, in the various stages of manufacture; and vulcanized or converted.

Of impermeable India-rubber manufacture: inflated boats; life belts; cushions, pillows, beds, and sponging baths; sheets for covering waggons, ricks, &c.; waterproof garments; sporting and travelling articles; water and air proof fabrics; invalid beds, &c.

Impermeable and elastic: decanter and bottle stoppers; wearing apparel; boots, shoes, &c.; surgical and veterinary articles; articles for chemical uses; calico-printing articles; ship sheets, in case of accidents at sea, &c.

Elastic articles: for domestic purposes in sheet or woven articles; springs for doors; bands and bandages; buffer and bearing springs for carriages; tires for noiseless wheels, sewer and sink valves; torsion spring roller blinds; Hodges' cumulants, by which a new power is obtained for raising and suspending weights, constructing presses, and projecting balls, shot, harpoons, arrows, &c.; washers for flange and socket joints, &c.

Moulded articles for various mechanical uses; socket washer in glass model pipe; rolling piston in glass model pump; packing for steam-engines, &c. Ornamental articles for stationary purposes, &c.; elastic maps, prints, and embossings, printed webbing; thread for weaving into elastic fabrics, and ladies' ornamental work, &c.

[The process of vulcanizing, by which so many new and extraordinary qualities have been given to India-rubber, was discovered by Mr. Thomas Hancock, of Stoke Newington, a partner in the above firm, and patented by him in November, 1843.

These qualities consist, first, in a remarkable increase of strength, and a permanent elasticity. Secondly, in its resistance to the action of the essential oils, which dissolve common India-rubber, the vulcanized merely absorbs them, as a sponge does water, and from which it may be evaporated without injury to the qualities acquired by vulcanizing—and its great resistance to the action of fatty oils; and, thirdly, its being unaffected at low temperatures, which hardens common India-rubber, whilst vulcanized remains in a soft and elastic state. It also resists the action of heat, far beyond those temperatures which destroy common rubber.

These qualities arise from a peculiar combination of sulphur with India-rubber by means of heat. This important discovery was made by Mr. Hancock on immersing sheet India-rubber in liquid sulphur, when he perceived that an extraordinary change had taken place in the rubber, which he discovered to be due to the absorption of the sulphur, and not absorption only, but by a continua-

tion of the heat to certain degrees until it was found to have acquired the properties above stated, which rendered it fit for many new and important purposes in the useful and mechanical arts; and many of its qualities thus discovered are now extensively employed for uses suggested by the vulcanized rubber itself; and for which, if it fail, there is no known substitute.

In waterproof fabrics, the impermeable quality of India-rubber is preserved, whilst it remains permanently flexible and elastic; for no degree of climatic temperature renders garments or coverings made with it stiff from cold, nor are they injured by heat.

But it is chiefly for its elastic properties that it has become so valuable, and many patents have been taken out for its application, such as buffers and bearing-springs for railway-carriages; washers for flange and socket joints of metal, glass and earthenware pipes; valves and cocks for retaining or transmitting fluids; valves for the air-pumps of marine and other steam-engines; threads and sheets of elastic fabrics; hydrostatic beds and pillows for local application, and a variety of valuable surgical applications. The new power for lifting, pressing, or suspending, or restraining for sudden disengagement, an accumulated elastic force, until it is equivalent to or exceeds the effect required to be employed.

Caoutchouc is the sap of the *Siphonia elastica*, a plant of the order *Euphorbiacea* or spurge tribe. The India-rubber tree is a native of Brazil and Guaiana, where it grows to a height of 60 feet and more, running up as a clear stem to 40 or 50 feet, and then branching. The trunk is tapped by a small pickaxe early in the morning, and a cup of soft clay is stuck beneath the wound to collect the milky juice, of which each tree yields daily about a gill. It is then moulded on clay into the bottle or shoe-like shapes in which it is brought to Europe; the layers of juice being dried in smoke. This vegetable constituent is also obtained in large quantities from the East, from the *Ficus elastica* and the *Urceola elastica*; the latter abounds in the islands of the Indian archipelago; it is a creeper so rapid in growth, that in five years it extends to 200 feet, and is from 20 to 30 inches in girth. This tree can, without being injured, yield by tapping from 50 to 60 lbs. of caoutchouc in one season; but it is very inferior in quality to that which is obtained from the *Siphonia*.—E. F.]

77 BUNN, LOCKINGTON, & Co., 19 and 20 *Walbrook*—Importers.

Specimens of the various descriptions of native Para India-rubber, or caoutchouc, and of gutta percha (or gum gutta) as imported; classified according to their value and application; with samples showing the various stages of the manufactured articles.

Specimens of the various qualities of East and West India-rubber, as imported, which are used, with few exceptions, for the purpose of mixing with Para India-rubber and other substances. A few samples are exhibited to illustrate their use in manufactures.

[Since the year 1830, caoutchouc has been largely imported, principally from tropical South America. The average annual importation of it into England from Brazil during the three years ending with 1842, was no less than 3,790 cwt. The application of this substance to the making of boots and shoes is a branch of commerce that originated in the United States.—E. F.]

78 NICKELS, CHRISTOPHER, & Co., 13 *Goldsmith Street, Cheapside*—Manufacturers.

Various articles manufactured from India-rubber:—Woven elastic webs, for braces, garters, and

glove tops; braided webs for sandals, and similar purposes, under patent; elastic cord for various purposes, such as bead-threading for bracelets, armlets, neck chains, &c.

81 MATTHEWS, SAM., 58 *Charing Cross*—Manufacturer.

Large sized India-rubber portable boat, after the design of Lieut. Halkett, R.N.; useful for lake fishing, duck shooting, and general purposes. The air-proof cylinder running round this boat is made in four compartments, thereby considerably lessening the danger that might arise from its being fractured in any part.

India-rubber cloak boat, designed by the same, made of ordinary waterproof material, fitted with an airproof cylinder, which, when inflated, renders it capable of being used as a boat, and enables travellers to cross rivers or streams where no other means are at hand; it also forms a good bed.

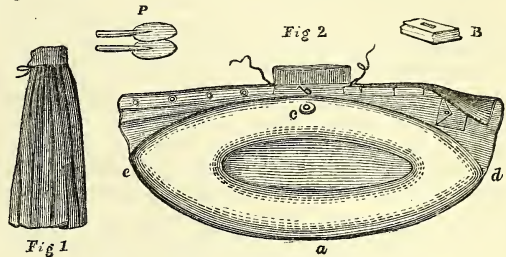

Lieut. Halkett's India-rubber Cloak Boat.

In Fig. 1, is shown the cloak boat uninflated. A large portion of the cloak is doubled in the cloth, and when air is forced between the two parts, a firm distended cylinder is formed, somewhat in shape like a horse-collar. In Fig. 2, is shown the cloak thus inflated, through the cock, *c*, by a small bellows, *B*. Within the circumference of this air-cylinder, and on the centre part (which does not inflate) the owner sits when on the water.

All beyond the length and breadth, *a b, d e*, of the boat, as the collar, loose skirts, &c., is drawn in, and so kept out of the water by a running cord.

P, the paddles, *B*, the bellows, both of which are carried in the cloak pocket.

India-rubber portable bath. This has an inflating border, which gives it the necessary form when filled with air; when uninflated it is capable of being packed in a very small compass.

82 CORDING, J. C., 231 *Strand*—Producer.

Silk and other waterproof coats, capable of being used with either side outwards. Waterproof capes of a new form. Ladies' waterproof silk capes and hoods, made of silk. Sundry waterproof articles.

83 HANCOCK, J. L., *Goswell Meus, Goswell Road*—Manufacturer.

Vulcanized India-rubber hose-pipes, and various descriptions of vulcanized India-rubber tubing. Portable India-rubber shower-bath. Hose-reel, with garden-hose attached. Inflated India-rubber bed-chair and cushion combined.

84 BAKER, C., *Jireh Cottage, Rotherfield Street, Islington*—Inventor.

New hair-brush and pocket tooth-brush. Model writing-desk. A new fire-escape. New pattern tooth-brushes.

85 The GUTTA PERCHA COMPANY, 18 *Wharf Road, City Road*—Importers, Patentees, and Manufacturers.

Blocks of raw gutta percha, one of them showing the deception practised by the Malays, in putting stones, &c., into the blocks. Trays of sliced and cleansed gutta percha.

Waterproof applications:—specimens of covered canvas and patent waterproof cloth of gutta percha; waterproof

soles for boots and shoes; "solutioned" jean for inner soles; hydropathic bandages; waterproof heels with metal tips.

Various articles for agricultural and manufacturing purposes.

For maritime purposes:—anchor floats, buoys, fishing-net floats, life buoys, and air-tight life-boat cells, pilots' hats, sou'-wester hats, coils of round band for signal haliards, speaking trumpets.

Decorative applications:—brackets, console tables, cornices, ceiling centres, mirror, and other frames, friezes, girandoles, panels, mouldings in imitation of carved oak, rosewood, &c., for the decoration of rooms, ships, saloons, cabinet work, &c.

Specimens of gilded gutta percha, and a variety of articles, showing its applicability for surgical, chemical, electrical, and domestic purposes.

[The history of gutta percha is remarkable. It appears to have been one of the curiosities introduced by the Tradescants into England under the title of *Mazer-wood*. But it received no commercial attention until 1843, when it was again brought to England, by Dr. D'Almeida and Dr. W. Montgomerie. Some of the earliest specimens were exhibited to the Society of Arts; and the curious properties of this substance, and its facile manipulation, were then illustrated. It now forms a most important article of commerce. From Singapore, in 1845, 169 piculs (a picul = 133½ lbs.) were exported; in the following year, 5,364; in 1847, 9,296; and in the first seven months of 1848, 21,598 piculs were shipped from Singapore to England. Gutta percha (pronounced pert-sha) is the concrete juice of a tree belonging to the natural order *Sapotaceæ*. This tree, *Isonandra Gutta*, abounds in the Malayan archipelago, and is called "Niato" by the natives. The concrete juice is prepared for manufacture by cutting into thin slices, by a powerful machine for that purpose. It is then boiled, and torn to shreds by machinery; it is after this dried, and masticated by similar kneading-machines to those used for caoutchouc. It is coloured by the introduction of colour in powder during the kneading process. Gutta percha is soluble in naphtha, chloroform, and other menstrua. The latter solution is useful in surgery.—R. E.]

85A FOUCART, Dr., 59 *Arlington Street, Mornington Crescent*—Inventor.

The gutta percha clavicular splint. This instrument is so constructed that it can be fitted to an arm of any shape or size, and a fracture of the clavicle may be reduced, and the ends of the bone retained in perfect apposition, merely by drawing the shoulder and belt straps to the requisite degree of tightness. The whole process only occupies half a minute.

86 THORN & Co., 98 *New Bond Street*—Manufacturers.

Looking-glass frames and console tables, and decorations in gutta percha; some richly gilt, and various specimens.

87 WALKER, THOMAS, 1 *Conduit Street, Regent Street*—Inventor and Manufacturer.

Gutta percha hat-bodies, previous to being finished. Ventilated velvet hats. Hunting helmet covered with silk velvet. Hat-case, answering the purpose of a safety life-buoy float, or as a foot-bath, and many other useful purposes. Portable rustic fountain. Letters and numbers for shop-fronts and other surfaces.

90 WEST HAM GUTTA PERCHA COMPANY, *West Ham*—Manufacturers.

Articles for manufacturers—driving bands for machinery, flat and round; bosses or rollers for flax, cotton, and worsted spinners; carboy, syphon, funnel, bucket, imperial measures, particularly useful in acid, alkali, chemical, dye, and print works, &c.

Useful articles—wire covered with gutta percha for electric telegraph purposes, especially for sub-marine and underground uses; sheet; soles and heels for shoes; tubing for the conveyance of water, air, acids, alkalis, chemicals, liquid manure; also for speaking tubes, fitted with mouth-pieces, and whistles; cups; basin; pulpit tubes for the deaf, in churches and chapels; railway conversation tubes; ear trumpets.

Ornamental articles—picture frames, brackets, trays, plates, inkstands, whips, draughtsmen, dice boxes, whistles, deer and hound, deer stealer (panel), deer at bay (panel), for which patents have been taken by Charles Hancock.

91 FAULDING, J., 11 *Edward Street, Hampstead Road*—Producer.

Fretwork cuttings.

95 SMITH, OSCAR, 21 *King St., Covent Garden*—Manufacturer.

Specimen of ivory turning and carving, forming a pedestal, vase, and flowers.

Unique specimen of ivory turning; a solid piece, the form of an egg, hollowed out to the thickness of the natural shell from a perforation of the 12th part of an inch. Turned by George A. Smith, 22 *May's Buildings, St. Martin's Lane*.

96 CLAYTON, B., 54 *Mansfield Street, Kingsland Road*—Inventor.

Specimens of a newly-invented method of making calico-printers' blocks and rollers.

Method of inlaying wood, gutta percha, Parian cement, papier maché, &c.

The blocks were prepared by the exhibitor without the advantage of skilled labour in such articles.

Newly-invented stamp, for stamping letters, newspapers, &c.

97 GRUGEON, ALFRED, 24 *Thomas Street, Hackney Road*—Designer and Manufacturer.

Fish and flower-stand, bird's-eye maple, and dyed to imitate nature.

98 TURNBULL, THOMAS, *William Street, Portland Town*—Producer.

Specimens of improved wood sawing, applicable to sawing deals into all sizes.

99 MINNS, JAMES, 40 *Luard Street, Caledonian Road*—Maker.

Model of the choric monument of Lysicrates, at Athens. Lantern of Demosthenes, B.C. 334; scale ¾ of an inch to the foot. Carved in chestnut.

100 SCHOOL FOR THE INDIGENT BLIND, *St. George's Fields, Southwark*—Manufacturers.

Articles manufactured by the blind. Worsteds hearth-rugs and fire screen. Work and linen basket. Antimacassar and doyleys, knit with thread. Netted silk purses and neck ties. Watch pockets. Hair brooches, bracelets, watch guards, rings, and ear-rings. Figures cut in paper by a female, blind from infancy, 65 years of age. Doll's cradle. Chaise panel. Table mat. Set of shoe brushes. Five pairs of shoes. Cocoa-nut matting. A frame used in teaching the blind to write. A map in relief. Pattern board for the use of the blind in making fancy hearth-rugs.

101 CRIPER, ROBT., 18 *Artillery Lane, Bishopsgate Street Without*—Inventor and Manufacturer.

New willow drawing-room chair, easy, and inexpensive. The willow sofa-bed chair, which may be used as a bed, a sofa, or a chair, and only occupy the same space as an ordinary chair.

102 WILLIAMS, JAMES, 40 *Exeter Street, Strand*—Manufacturer.

Linen basket of superior fineness.

103 BODE, HERMAN, 11 *Portsea Place, Connaught Square*—Inventor and Manufacturer.
Various specimens of basket manufacture.

104 POTTS, DANIEL, 18 *St. Dunstan's Hill, Tower Street*—Inventor, Designer, and Manufacturer.
Figured vase, for flowers, in basket-work, formed of inner and outer cases, the intermediate surface being waterproof.

106 MCRAE, JAMES, & Co., 17 *Ave Maria Lane*—Manufacturers.
Scotch wood articles of new design, consisting of work-boxes, reticules, folio blotting-cases, tea caddies, stationery cases, metallic note books, perfume bottle-cases, cigar chests, snuff boxes, cigar cases, bellows, razor cases, paper-knives, book markers, needle-books and cases, match boxes, lancet cases, hearth-brushes, knitting cases, penholders, penknives and cases, spectacle cases, &c., ornamented with paintings, tartan plaids, chequers, gold and silver scrolls, &c. Exhibited for workmanship and ingenuity, particularly the Scotch hinge.

108 MALLANDAIN & Co., 5 *James Street, St. Luke's*—Manufacturers.
Table inkstand, with stoppered ink glasses; with jointed ink glasses, with caps; and with one stoppered ink glass made from English sycamore, stained black and polished.

109 WHEATLEY, WM., 2 *Clistone Street*—Designer and Manufacturer.
Specimens of blocks or lasts for the feet.

110 BEGENT, THOMAS JOHN, 8 *York Street, St. James's Square*—Inventor.
Registered peg to secure linen whilst drying: also applicable to holding papers together.

111 SHEPPARD, FRED., 125 *Kingsland Road*—Proprietor.
Articles of fancy woodwork, manufactured in Ayrshire, consisting of needle, card, envelope and cigar cases, snuff-boxes, toothpick cases, and boxes to contain postage stamps.

112 SANDY & POWELL, 76 *George St., New Road*—Manufacturers.
Fret cut pedestal of walnut wood, suitable for the newel of a staircase, sideboard standard, or hall table, &c.; the shaft, top, internal, and external ornaments being cut out of the solid wood by means of a perpendicular saw, worked by machinery; thickness of the solid wood 8 inches. Fret cut truss or leg, of rosewood, suitable for a pianoforte, &c., relieved with carving, and fret cut bracket of mahogany, entirely cut and shaped by means of the same saw.

113 TAYLOR, C. & A., 30 *Berners Mews, Oxford Street*—Designers and Manufacturers.
Ornamental tablet, being a specimen of fretwork, cut by improved machinery; used in the decoration of pianofortes, organs, cabinet-work, &c.

116 ROUSSEAU, ALEXANDRE, 352 *Strand*—Manufacturer.
Shawl boxes. Velvet embroidery. Lace cases, writing-paper, and other ornamental cases.

117 HARRIS, SAMUEL & HENRY, 41 and 27 *Mansell Street*—Importers.
Specimens of sponges, with descriptions of their different uses.
Samples of harness polishes, dye, and polishing pastes, with specimens of their effects.

[The sponges used in commerce belong to a class of beings which occupy debatable ground between the animal and vegetable kingdoms. Different kinds of sponges are found in all seas, including those of Britain;

but the sorts suited for use are chiefly procured from the Ægean Sea, where they are torn by divers from the rocks on which they grow, at a depth of from five to as many as thirty fathoms.—E. F.]

118 BARBER, CHARLES A., *Soho Bazaar*—Designer.
Landscapes and figures, cut from paper with scissors, without copy or outline. Age of the exhibitor, 10 years.

119 BURGESS, JAMES, 1 *Johnson Street, Horseferry Road, Westminster*—Manufacturer.
Flower vase, cut from paper with scissors.

120 COLLINGS, JOHN, 14 *Great Ormond Street, Bloomsbury*—Inventor and Maker.
Arm-pad for journeymen tailors, designed to abolish cross-legged sitting.

121 WALLER, F., 49 *Fleet Street*—Manufacturer.
Commercial and diplomatic despatch writing-desk in rosewood. Small open desk for ladies, in rosewood.

122 JONES, JONATHAN, 25 *John Street, Cannon Street, St. George's East*—Inventor.
Shoe pegs, for use in making boots and shoes without welts or stitches. Sixteen lengths cut by hand, beginning at one-eighth of an inch; and ten lengths cut by machine.
Shoes made with pegs; and in the different stages of manufacture.

124 BASS, JOHN H., 6 *Featherstone Street, City Road*—Inventor and Manufacturer.
Specimens of corks cut by patent machinery. The machinery was originally patented in 1830, but it has since been much altered.

125 ESDAILES & MARGRAVE, *City Saw Mills, Regent's Canal*—Producers.
Specimens of novel uses of cork and of preparations of cork by steam machinery.
1. Specimens of finished hats, made of cork, with the vendors' names, and the respective weights.
2. Specimens of cork hat bodies, or foundations, made solely of cork.
3. Specimen of a cork hat-body, or foundation, strengthened by muslin, as generally made and used by the trade.
4. Specimens of cork plates, cut by steam machinery, varying from 50 to 120 plates in the inch, in the state in which they are supplied to the hat-body makers.
5. Specimens of cork tip pieces, of the like nature, in the state in which they are supplied to the hat-body makers.
6. Specimens of cork hat cylinders, partly prepared and made up, in the state in which they are supplied to the hat manufacturers.
7. Specimens of cork hat brim plates, in the state in which they are supplied to the hat-body makers.
8. Specimens of cork hat brims, partly prepared and made up, as supplied to the hat manufacturers.
9. Specimens of printing on cork plates, with type and engraved blocks, exhibited by Mr. A. J. Mayer, inventor of the steam machinery, employed at the City Saw Mills in this trade.

Fibre cut from cork by steam machinery, in its prepared condition, for the stuffing of ships' mattresses, and boat cushions, to be used at sea for the preservation of life.

1. Specimen of a sea mattress, partially stuffed with cork fibre. 2. Specimen of the same, finished. 3. Specimen of a circular bolster, similarly stuffed. 4. Specimen of the application of cork fibre, applied as a packing to the stuffing-boxes of steam-engine piston rods, and which is said to require no lubricating material.

Floating models, illustrative of the mode of using the cork fibre mattresses and bolsters, as life preservers at sea.

- 126 FRENCH & BUTLER, 28 *Piccadilly*—Manufacturers and Importers.
Specimens of different qualities of ready-made corks of English and Spanish manufacture.
- 127 BLIZARD, JOHN, *Cheltenham*—Manufacturer.
Moulded panels and mouldings cut by machinery, showing the stages of the working, with the tools employed in the process. The machine is specially adapted for running joiners' work.
- 128 FRANKS, C., *Wolverhampton*—Manufacturer.
Basket, for clothes.
- 131 PETERS, RICHARD, & SON, *Birmingham*—Manufacturers.
Tortoiseshell clock-case, inlaid with pearl and silver in scroll pattern, with painting of St. Paul's Cathedral; the movement by Mr. Evans, of Handsworth.
Writing-desk of tortoiseshell, inlaid with various coloured pearls in scroll-work, new design. Tea-chest in tortoiseshell.
Cigar magazine, to hold six dozen cigars, in tortoiseshell, with sporting design on lid; the same in turtle-shell, embellished with painting of Mytton's celebrated leap.
Tea-caddy in mother-of-pearl, inlaid with coloured pearl. Tea-caddies in tortoiseshell of various shapes, inlaid, &c.
Hair-brush, inlaid with gold, silver, and pearl. Card-cases in various coloured pearls and tortoiseshell, of new designs and patterns. Cigar cases, tortoiseshell, inlaid.
Several articles of small manufacture, viz., brooches, coat-links, needle-cases, match-boxes, spectacle cases, tablets, &c.
Ladies' companion of variegated pearl. Work-box in mother-of-pearl, set with garnets, &c.
Tortoiseshell cabinet, inlaid with pearl; new pattern, with drawers, desk, and work-box complete.
Lady's card-case, in two coloured pearls, consisting of 730 distinct pieces of diamond-shaped shell.
Card-case, novel shape, in tortoiseshell, studded with silver, with painting in the centre.
[After being cut from the shell, the pieces of mother-of-pearl are flattened on an ordinary grinding-stone, they are then attached to the skeleton-frame, which forms the box or case, and are reduced to a uniform surface by files or scrapers; pumice-stone and putty-powder is next employed, and buff-leather, upon which rotten-stone has been rubbed, is used to impart the final brilliancy.—W. C. A.]
- 132 HAYDEN, JOHN, 35 *Northwood Street, Birmingham*—Designer and Manufacturer.
Lady's cabinet, and small cases—tortoiseshell, and pearl.
- 137 WHITAKER, H. W., 20 *Charlotte Street*—Manufacturer.
Ornamental bird-cage.
- 138 SPRINGFIELD, WILLIAM, *Wisbech*—Designer and Manufacturer.
Models of wine pipes, casks, tubs, churns, and other articles of cooery.
- 141 GARRETT, G., 1 *Victoria Terrace, Woodbridge Road, Ipswich*—Manufacturer.
Ornamental turned snuff-boxes, in ivory, and fancy foreign woods.
- 143 GOULD, JOHN, *Tottenham Park, Marlborough*—Designer.
Bible, with cover in carved oak and silver-plated clasps; worked by hand. (See the engraving, Plate 85, at page 541.)
- 144 RENDALL, JOHN, *Stromness, Orkney, Scotland*—Manufacturer.
Various samples of Tuscan plait suitable for bonnets. Specimens of 11 straws, fine Tuscans, and of 15 straws, coarse Tuscans. Grown and dressed in Orkney, and plaited by the female inhabitants.
- 145 STILL, CHARLES STEWART, *Smoogrow House, near Kirkwall, Scotland*—Proprietor.
Specimens of the straw plait, for making bonnets, hats, &c., which affords employment to the women of Orkney. The manufacture of this plait was established about 1820.
- 146 MACGREGOR, J. W., 28 *Jamaica Street, Glasgow*—Manufacturer.
Ships' harness cask, brass hooped and mounted, used for holding beef. Deck buckets, brass hooped; brass hooped and handle; and brass hooped and wooden handle. Pump can, brass hooped and handle. Mess kid, brass hooped.
Imperial bushel measures, brass hooped and mounted, with hoops flush with the staves; brass mounted and iron hooped, with handles.
Ten gallon cask, made out of red oak staves (a porous wood), and rendered tight by charging the chimb of the cask with melted tallow, a method which enables the cooper to use staves of red oak for water casks.
- 151 COOPER, W. M., *Derby*—Producer.
Pulpit, with carved figures, &c.
- 152 STEVENSON, J. & J., *Sheffield*, and 9 *Cripplegate Buildings, Wood Street*—Manufacturer.
Ladies ornamental, dress, and other combs, manufactured from ox and buffalo horns.
- 154 TOPLIS, JOHN, & SONS, *Ashby-de-la-Zouch*—Designers and Manufacturers.
Improved royal letter-basket; colours, red, blue, and white; for the drawing-room.
Complete fancy knitting-basket; colours, red, blue, and white, with compartments.
Round work-basket, with dome top; colours, red, blue, lilac, green, and white.
Fancy cottage dog-kennel; blue and white.
- 155 DUNLOP, JOHN, *Lauder, Scotland*—Inventor.
Fishing or trout basket.
- 156 ADAMSON, ROBERT, *Colingsburgh, Fifeshire*—Designer and Manufacturer.
Scotch willow basket for carrying fine fruits. Manufactured by the exhibitor at Balcarres gardens, during the winter of 1850.
- 157 HALLIDAY, WILLIAM, *Chilton-super-Polden, near Bridgwater*—Producer.
Piece of carving in English oak, 3 feet long, 2 feet in width, and 7 inches in thickness. Subject, "The Canterbury pilgrims setting out from the Tabard." Executed by the exhibitor.
- 158 HEMPHILL, W. D., *Clonmel, Ireland*—Designer and Manufacturer.
A vase, in the Elizabethan style; a miniature frame; a vase, after the antique, with lily of the valley and fuschia; and twelve dessert knife-handles, of various designs: all executed in ivory.
A candlestick and a match-holder, in African blackwood and ivory.
A small vase, after the antique, in walrus ivory, showing the beautiful reticulated appearance of the interior of the tooth when turned extremely thin; a small cup, in the same material, showing the great strength of the enamel of the tooth of which the slender pillar is turned; vases in hippopotamus ivory.

- 159 CANNINGS, MARY JANE, 9 *Walcot Parade, Bath*—
Manufacturer.
Models of a lady's travelling-basket, an invalid's bed-table, of vegetable and fruit baskets, and of linen, bonnet, plate, and bottle baskets. Chair-back and hand-screens. Dinner and round mats. Bushel, knife, work, clothes, and market baskets. Bouquet-holder. Flower-pot stands.
Baskets for various uses.
The exhibitor is blind, deaf, and dumb.
- 160 HORNE, WILLIAM, 54 *Montague Street, Spitalfields*—
Designer and Manufacturer.
Ladies' work-box, containing 1,500 pieces of wood, of about 70 different kinds, the produce of different countries.
- 161 HAWLEY, JAMES & THOMAS, 181 *Bromsgrove Street, Birmingham*—Manufacturers.
Specimens of tooth, nail, shaving, hair, and hat brushes, made of bone.
- 162 TATE, F., 18 *Percy Street, Bedford Square*—
Producer.
A gilt casket symbolical of the Great Exhibition of Industry of all Nations. Plastic casts in imitation of metal.
- 163 WILLIAM, H., *Dublin*—Inventor.
Eccentric ivory turning, without eccentric chuck.
- 164 SHAW, C., *Mount Street, Dublin*—Producer.
Specimens, in ivory, of mechanical sculpture, reduced from models in plaster by machinery adapted to a turning lathe.
- 165 MEADOWS, JOHN, 71 *Princes Street, Leicester Square*—
Inventor, Patentee, and Manufacturer.
New method of veneering: specimens of a veneered glass-case; Grecian and Doric column and capital, adapted for all kinds of upholsterers' work, cabinet, and piano-forte. Picture frames. Specimens of patent builders' work, without joining at the angles or edges.
- 166 HOWTON, GEORGE WILLIAM, 34 *Thayer Street*—
Manufacturer.
Decorative panel, carved out of lime-wood.
- 167 MITFORD, BERTRAM, *Cheltenham*—Maker and
Inventor.
Concentric-balls, made of solid spheres of box-wood. This curious art was first introduced by the Chinese.
[The mode in which the Chinese make these balls has been lately explained. In the Athenæum (No. 1094), a correspondent gave an account of one which he had examined, and in which he found that more holes had been cut out of the spheres during the working than were finally to appear, some of them being afterwards plugged up by pieces very well screwed in. He then gave a very probable account of the way in which the whole was done, and this was confirmed (No. 1096) by a gentleman who had seen the manufacture in China.—A. D. M.]
- 168 WINTERBORN, JOHN, *Hackney Road*—Inventor
and Designer.
Models: self-acting index, in case of spontaneous combustion on board of vessels; portable warm-bath; self-acting extinguisher, in case of an overheated flue; self-acting fire-escape, alarm, and an indicator; groups of carving in Italian walnut-tree.
- 169 DAY, HENRIETTA, 4 *Oakley Terrace, Old Kent Road*—
Producer.
A caddy formed of rare and valuable shells to the number of 100,000, the interior of the lid displays a bouquet of flowers worked in beads.
- 171 BEVAN, CHARLES, 100 *Metropolitan Buildings, St. Pancras*—Designer and Producer.
Carved walnut tea-chest, executed by hand; exhibiting the art of wood-carving in the various stages, from its commencement to its completion.
- 172 SMITH, THOMAS, *Hurstmonceux, near Hailsham*—
Manufacturer.
A set of Sussex truck-baskets, made of willow wood.
- 173 WOLSTENHOLME, J., 12 *Lord Mayor's Walk, York*—
Designer and Manufacturer.
Six stall finials, or poppy-heads, of decorated Gothic architecture, and various designs, carved in Norway oak.
- 174 STRUGNELL, H., 25 *Kirby Street, Ilutton Garden*—
Producer.
Ornamental writing-desk.
- 175 PEEL, JOSEPH, *Pudsey, near Leeds, Yorkshire*—
Producer.
Specimens of ornamental turning, cut in relievo, in wood, copied from coins, medals, and flowers, and of ornamental turning cut in relievo in marble, from medals and flowers, by automatic machinery, the turnery averaging 1½ hour for each copy. Presented simply as the turning tool left them; they require no attendance from commencing to finishing.
- 176 MOORE, G. W., *Huddersfield, Yorkshire*—Producer.
Wood carvings.
- 177 HAMILTON, CHARLES FOSTER, 15 *Greek Street, Soho*—
Inventor and Manufacturer.
Specimen of shaving brushes.
- 178 FORSTER, —, *Streatham, Surrey*—Producer.
Patent and other fabrics.
- 179 ROGERS, MARK, *Abbey Street, Derby*—Manufacturer.
Ornamental bracket, composed of autumnal fruits and flowers, carved in lime-tree.
- 181 FRINNEBY, F. R., 63 *Cannon Street, City*—Inventor
and Manufacturer.
Registered distempers and other brushes for painting and graining purposes.
- 182 BUSHELL, G., 222 *Whitechapel Road*—Inventor.
An economical substitute for stained glass, suitable for all kinds of ornamental and transparent devices.
- 183 GODFREY, W., *Romford*—Producer.
Ornamental window, and model of a life-boat.
- 184 HALL, J. S., 308 *Regent Street*—Manufacturer.
Improved elastic over shoes, with leather soles and plush heels, to prevent slipping.
- 185 TAR BUTT, W., *Cranbrook, Kent*—Designer and
Manufacturer.
Cradle, made of osiers, and ornamented with upwards of a hundred diamonds of the same material. It is put in motion by a weight and springs.
- 188 HORSEY, JAMES, 5 *Sutton Street, Soho Square*—
Inventor and Manufacturer.
Various articles of India-rubber manufacture, in its original colour, designed to resist the influence of heat and cold, and the action of unctuous matters.
Specimens of the same substance in various colours; in sheet, and in manufactures of different articles, both solid and spread on fabrics. The colours are permanent, and the combination is designed to resist the influence of atmospheric temperature, unctuous matters, and many chemical menstruums.

191 WOODHEAD, J., *Leeds, Yorkshire*—Manufacturer.

Bell ropes; flax web; hempen ropes; worsted netting for protecting fruit trees from frost.

192 GRIFFITHS, WILLIAM, 29 *Grafton Street, Dublin*—
Inventor and Manufacturer.

Elastic snake bracelets, double and single coils, made of bog oak, and with alternate joints of bog oak and yew. Bog oak paper knives, brooches, studs, buttons, penholders, watch-chain ornaments. Bog oak brooches illustrating four celebrated ruins in Connaught, Ulster, Munster, and Leinster. Irish harp brooches, with Irish beryl, pearls, and diamonds. Various bracelets and brooches.

193 CAWLEY, J., 21 *Bridgwater Gardens, Bridgwater Square, Barbican, City*—Manufacturer.

Various mats and rugs.

194 CURTIS BROTHERS, 29 *Green Street, Friar Street, Blackfriars Road*—Manufactory.

Gut band, for driving steam-engines, manufactured from animal substances.

195 HEMENS, N. J., *Hayes, near Usbridge*—Inventor.

A hoof of a horse shod with gutta percha, with an accompanying shoe.

196 HINDE, JOHN GEORGE, 144 *Broad Street, Birmingham*—
Designer and Manufacturer.

Specimens of fancy brushes, showing process of manufacture.

Specimens of various kinds of useful brushes, and models of apparatus for making them.

197 CLARKSON & Co., 111 *Strand*—Manufacturers.
Specimens of patent cork hats.

198 STEVENS, JOHN, 4 *Penton Row, Queen's Row, Walworth*—Producer.

View of the Exhibition in a composition, made at St. John's Wood.

199 DEWSNAP, JAMES, *St. Thomas's Street, Sheffield*—
Manufacturer.

An assortment of superior and useful razor strops. Military strops, expressly for the army and navy, made portable to contain a razor. Coromandel seven-razor case, gimped, silk velvet cushion. Albina-wood seven-razor case. Real Russia seven-razor case, gilt, silk velvet cushion. An assortment of razor-cases, of superior finish and quality. Gentlemen and ladies' real Russia and Morocco pocket-books. Scissor cases, to contain three or four pairs, gilt, in calf and silk velvet. Some beautiful specimens in Ladies' Companions, gilt, in calf and silk velvet, embossed with gold.

200 HAWKINS, THOS., 3 *Inverness Terrace, Bishop Road, Bayswater*—Patentee and Manufacturer.

Specimens of brushes.

201 WATSON, JOSEPH, *Newcastle-upon-Tyne*—
Proprietor.

Vegetable ivory nut; the same prepared for carving; and carvings executed by R. Scott, Newcastle.



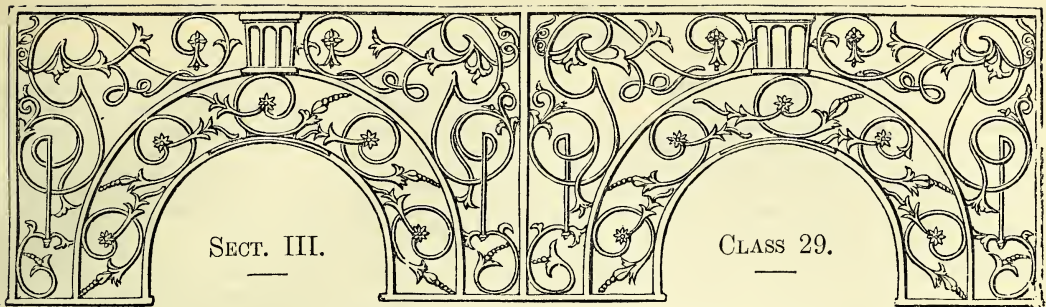

MISCELLANEOUS MANUFACTURES AND SMALL WARES.

INTRODUCTION.

THE miscellaneous character of the objects included in this Class renders it difficult to convey a precise idea of its general import, or of the distinguishing features of the articles exhibited under it. Small wares may be taken to comprehend a very large variety of articles, and miscellaneous manufactures necessarily include a similar variety. The following feature may, however, be considered to characterise the articles brought together under this Class, that they are principally, though not exclusively, related to the minor points in the domestic economy of society. And this will be evident on examination of the Sub-Classes into which it is divided.

These are as follow:—A. Perfumery and Soap; B. Articles for personal use, as Writing-desks, Dressing-cases, Work-boxes, when not exhibited in connection with precious metals and travelling gear generally; C. Artificial Flowers; D. Candles, and other means of giving light; E. Confectionery of all kinds; F. Beads and Toys, when not of hardware, Fans, &c.; G. Umbrellas, Parasols, Walking-sticks, &c.; H. Fishing-tackle of all kinds, Archery, &c.; I. Canes of all kinds; J. Other miscellaneous manufactures.

These articles are placed in the North Transept Gallery. Included, however, among the miscellaneous objects are two valuable and important collections which scarcely appear to come under proper recognition in this Class. These collections are of the imports of the towns of Liverpool and Hull. They have been arranged with great care, and present an excellent picture of the staple articles of trade, and of many of the less important ones, constantly received as importations from abroad by these flourishing sea-ports. The list of the Liverpool Collection has been inserted in the body of this Catalogue, in consequence of the value attaching to accurate statistical local information. This list has undergone careful scientific revision, and its generic expressions may be taken as, on the whole, accurate.

The manufacture of soaps and candles is the only one of great commercial importance to which this Class has relation. The employment of soap in many processes of manufacture, in addition to the immense demand created by domestic necessities, render its production on the great scale proportionally interesting. The rate of increase in the quantity produced, during the last half-century, may be estimated from the fact that, in 1801, 52,947,037 lbs. of soap were consumed; and, in 1849, the annual consumption amounted to 197,632,280 lbs. The quantity per head amounted, in the latter year, to 9·71lbs. annually; in the former to 4·84lbs. But much of the increase of consumption is to be attributed to the development of manufactures in which this substance is used for various purposes. It is a remarkable fact that, during the same period, the number of licensed makers of soap has decreased to the extent of one-half, while the production has increased by two-thirds and upwards. Chemical science has applied itself to this manufacture with much success in this country, and the best soap is produced at a rate very inferior to that of indifferent soaps in other countries, and in our own at a former period.

The candle manufacture is also conducted on a very large scale. The introduction of oil, camphine, gas, and other means of giving light, does not appear to have very materially influenced this manufacture. The cause of which may, perhaps, be sought in the repugnance of many to apply gas to household uses, and in the convenience of the use of a solid instead of a fluid material for domestic lights. Chemistry has effected much for this manufacture. By its aid a new material has been produced which has become a most extensive substitute for wax and spermaceti, not only in this but also in foreign countries. Fiscal restrictions having been removed, the improvement in the candle manufacture has been most striking, and the benefit to the public and to commerce proportionate.

The minor articles comprised within the limits of this Class do not require special notice. Perfumery, articles for the dining-table, models in wax, toys, fishing-tackle, &c., have all their respective importance, and may, by those interested in them, be studied in the locality already named.—R. E.

- 1 ROWLAND, ALEXANDER & SONS, 20 Hatton Garden—
Proprietors.
Articles of perfumery and for the toilet; oils, cosmetics, dentifrices, &c.
- 2 YARDLEY & STATHAM, 7 Vine Street, Bloomsbury—
Manufacturers.
Specimens of refined scented soaps.

- 3 RIMMEL, EUGENE, 39 Gerrard St., Soho, and
19 Boulevard de la Gare d'Ivry, Paris—Producer.
Artificial hair, to imitate human hair, for plaits, &c.
A scent fountain, a jet for cooling and perfuming apartments, &c.; kept in motion by a descending weight, and wound up like a carcel lamp. Scented winter bouquets, composed of artificial flowers. Various articles of perfumery and for the toilet.

- 4 **WILLIAMS, JOHN, & SON, 28 Compton Street, Clerkenwell**—Manufacturers.
White oil soap, produced from Gallipoli oil, much used amongst the fine cloth manufacturers. Fine curd soap, used at Nottingham amongst the lace-bleachers. Curd soap, used by the cloth and other manufacturers of woollen goods. Scouring soap, principally used at Leicester, also in the manufacture of goods. Mottled and yellow soap, similar to that sold by oilmen and grocers. Various kinds of fancy soaps (perfumed).
- 5 **TAYLOR, HUMPHREY, & Co., King's Road, Chelsea**—Distillers.
Specimens of liqueurs distilled from foreign and English fruits, &c., of a British spirit; of distilled waters, extracted from flowers, herbs, &c.; of fancy scented soaps.
- 6 **LLOYD, ANDREW, 10 Beak Street, Regent Street**—Manufacturer.
The Euxesis, for shaving without soap or water.
- 8 **KNIGHT, JOHN, Old Gravel Lane, St. George's, Middlesex**—Manufacturer.
Extra pale yellow soap; exhibited for utility and composition.
Soft soap—used in the manufactures of cloth, silk, &c., for machinery, on railways and on other works, for washing sheep and cattle, &c.
- 9 **WARNER, W., Wisbech, Cambridgeshire.**
Models of two casks and a filter.
- 10 **HENDRIE, ROBERT, 12 and 13 Tichborne Street, Quadrant**—Manufacturer.
Toilet soaps.—Petrolina soap, and other fancy soaps. British perfumes:—a pure lavender water, from British flowers only. Specimens of various perfumed essences. Cosmetic preparations for preserving the skin. Improved milk of roses. Improved spirituous acetine, or toilet vinegar. "Moelline," a peculiar oleaginous compound. Specimens of various articles connected with the toilet.
- 13 **GROSSMITH, JOHN, 39 Friday Street**—Manufacturer.
Summer and other fancy soaps; pomade, essences; perfumery, and essential oils.
- 14 **CLARNE, W. R., 27 Compton Street, Clerkenwell**—Producer.
A walking-stick.
- 15 **BARNES, J. & W., Poyle, near Colnbrook**—Manufacturer.
A variety of whiphongs.
- 16 **CARRICK, JAMES, 127 Crawford Street**—Inventor and Proprietor.
Sample of the cosmetic elder-flower toilet soap, free from all stimulating perfumes.
- 17 **GALBRAITH, W. J. T., 26 Bennett Street, Blackfriars Road**—Inventor and Manufacturer.
Writing fluids. Seidlitz powders. Marking ink. Culinary essences. Hair oils, perfumes, &c.
- 18 **EDE & Co., 47 Ludgate Hill**—Manufacturers.
Articles of perfumery. Waithman's patent ink.
- 19 **COWAN, LEWIS, & SONS, 139 New Gravel Lane, Shadwell**—Manufacturers.
Specimens of pale yellow, mottled, curd, and marine soap.
- 20 **CLEAVER, FREDERICK SAMUEL, 18 Red Lion Square**—Inventor and Manufacturer.
"Honey toilet soap."
Specimens of "May blossom," or "summer soap," being composed of "cream of tartar" with "honey soap."
"Winter soap," (honey soap combined with camphor.)
Specimens of "peach-blossom soap," free from colouring matter.
Brown and white Windsor, and white almond soaps.
- 21 **FARINA, JEAN MARIE, 23 Rheinstrasse, Cologne, and 1 Salters' Hall Court, Cannon Street, City**—Manufacturer.
A new extract of Eau de Cologne, playing from a fountain.
- 22 **FISHER, T. W. & Co., King's Head Court, Barbican**—Manufacturer and Patentee.
Perfumery and chemicals.
- 23 **STEVENSON, DAVID, 4 Carlton Street, Regent Street**—Manufacturer.
Eau de Cologne. This perfume is manufactured in this country, and contains the peculiar qualities which are supposed to be confined to the foreign article, while it can be sold at a less price.
- 24 **PEARS, ANDREW & FRANCIS, 91 Great Russell Street, Bloomsbury**—Inventors and Manufacturers.
Specimens of transparent soap.
- 25 **KENDALL, JOHN, & Co., 32 Hanover Street, Dublin, Manufacturers; Agent, KENDALL, JOHN, 8 Harp Lane, Great Tower Street, London.**
Sixty boxes fancy perfumed soaps, assorted. Twelve slabs fancy soaps, of various colours, in rosewood frames, glazed.
Twenty-four bottles of perfumes, assorted; imported by the exhibitors, from the Fabrique, at Aix-la-Chapelle.
The soaps manufactured at Hanover-street, Dublin; the boxes and decorations by W. Cornish, 63 Bartholomew Close, London. Manufactured without any deleterious ingredients.
- 26 **FAIERS, JOHN, 154 High Street, Colchester**—Manufacturer.
Vegetable oil for perfumery.
- 27 **WHARRY, JAMES, Market Place, Chippenham**—Manufacturer.
Distilled lavender-water.
- 28 **MACKEAN, WM., Paisley**—Manufacturer.
White soap. Pale soap, purified so as to retain its colour. White oil soap, finished by a process in which the glycerine is extracted. Palm-oil bleached without the intervention of chemicals.
Ammoniacal soap (soft). In making this soap, the alkali and fat are united instantaneously by a novel process. The colours of cloth subjected to this soap in washing are generally brightened, the reverse being the case with common soaps.
Purified American baking lard. Lard-oil, for machinery, freed from fat acids.
- 29 **PAYNE, GEORGE, Cowes, Isle of Wight**—Proprietor.
Royal Osborne bouquet—an improved perfume. Isle of Wight sand soap—made with the coloured sands of the island. Royal Osborne sauce—an improved condiment.
- 30 **LOW, R., & Co., 330 Strand**—Manufacturers.
Hair brushes in ivory, satinwood, and rosewood. Embossed perfumed soaps. Bottles of perfumery.
- 31 **GOULD, A., 36 Great Marylebone Street**—Manufacturer.
An assortment of fishing tackle.
- 32 **WARRELL, JAMES, Dofford Street, Bath**—Manufacturer.
Ladies' fancy work-baskets, made from the ground-ash and the hazel-nut, varnished with spirit varnish, and finished with silk and satin.
Large work-basket, fitted up with rose satin, in the shape of a boat. Large oval cover travelling work-basket, varnished brown, crimson lined.
Lady's jewel-casket, Albert blue, with a crochet covering. Bridal basket, light varnish, pink lined, with brass lock.

Long knitting-basket, varnished brown, blue satin lined, with padlock. Long tidy for crochet-needles, varnished dove colour, rose satin lined. Toilet pincushion, varnished pink, covered with white silk.

Lady's travelling refreshment basket. Pen tray, varnished brown, lined with blue. Green canoe, lined yellow, for fruit or flowers. Bronze tidy or key-basket, lined with green. White canoe, showing different sorts of wood. Model for a baby-linen basket.

33 ADAMS, SAMUEL, *Nottingham*—Inventor.

Instrument, to enable a blind person to thread a needle.

34 FROST, HENRY, 17 *Rathbone Place, Oxford Street*—Manufacturer.

Specimens of hot-water and steam apparatus.

35 STIVEN, CHARLES, & SONS, *Lawrencekirk, Scotland*—Inventors and Manufacturers.

Tea-chest, with a view of Scone Palace and pattern, Murray tartan. Lady's work-box, with a view of Balmoral and pattern, Royal Stuart tartan. Knitting-box, with a view of Melrose Abbey and pattern, Hunting Stuart tartan. Cigar-case. Needle-book. Postage-stamp box. Snuff-box, inlaid with various woods; snuff-box, with pattern, Royal Stuart tartan; snuff-boxes of partridge-wood and Amboyna-wood.

36 AUSTIN, GEORGE, 6 & 7 *St. Andrew Street, Dublin*—Manufacturer.

Dressing cases, made of Irish bog yew, from the county of Kildare. The silver fittings from the Sugenure mines, county of Wicklow. Improved silver-fitted dressing-case.

Coromandel wood writing desk, the top represents a leopard hunt, and the front a tiger hunt. Coromandel wood regency desk, inlaid with brass, mother-of-pearl, and different coloured shells.

Russia and morocco leather writing-boxes, and cases. Morocco leather backgammon boxes, gilt, varied sizes, patterns, and colours. Morocco leather despatch box. Pocket books, brush cases, roll-up dressing cases, &c.

37 BEST, THOS., 9 *St. Mary's Row, Birmingham*—Manufacturer.

Gentleman's fancy leather dressing-cases. Russia leather double writing-case. Ladies' fancy leather work reticule and dressing-case combined; ladies' reticules. Student's companion, note-case. Ladies' card-cases; and with tablet, imitation of inlaid tortoise-shell. Gentlemen's card and cigar cases. Ladies' companions. Pocket-books, and bill and bankers' cases. Spectacle-cases, fancy leather. Writing-desk.

38 HAYWOOD, M., *Birmingham*—Manufacturer.

Fishing tackle, in great variety.

39 PURDON, THOMAS, 68 *Whitefriargate, Hull*—Inventor and Manufacturer.

Registered travelling bureau.

The Hull safety oil-lamp, combining lantern and lamp. The flame is protected by a glass, on the top of which is a wire-gauge cone, to prevent the action of the air in draughts, &c.

Iron skate, made by Wm. Grantham, which runs on four small fluted wheels.

40 RUSSELL, ROBERT, *Tunbridge Wells, Kent*—Inventor and Manufacturer.

Tunbridge ware marquetry inlaid lady's work-box, fitted with a till, &c. Made in the Gothic style, and showing native woods.

41 HOLLAMBY, HENRY, *Tonbridge Wells*—Manufacturer.

Work-box and writing-desk, specimens of mosaic inlaid Tunbridge ware.

Specimens of English and foreign woods, with which these articles are inlaid.

42 STRUDWICK, THOMAS, 14 *New Bond Street*—Manufacturer.

Yew-tree writing-box, fitted with ebony, bronze antique mountings. Cedar of Lebanon dressing-case with silver fittings, hinges, locks, &c. Yew-tree dressing-case with Elizabethan silver fittings and ornaments. Ebony box with mediæval mounts. Ebony library ink-stand, with silver taper-stand and ink-glasses.

43 STOCKEN, CHARLES, 53 *Regent Street*—Manufacturer.

Envelope cases, blotting books, &c.

44 LEUCHARS, WILLIAM, 38 *Piccadilly*—Inventor and Manufacturer.

Lady's dressing-case of walnut-wood, the exterior mounted in the mediæval style, in pierced solid silver, enriched with gilt knobs and pins, and relieved with enamel coal; the interior fitted with massive chased silver tops, parcel gilt, and a new-pattern of swing glass in a silver frame.

This dressing case is represented in the annexed cut.

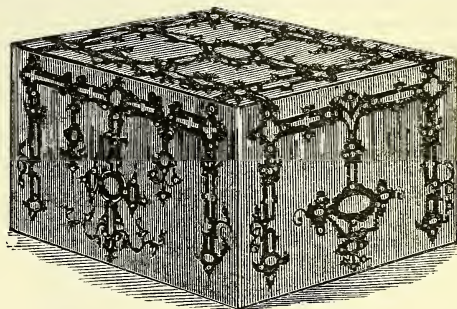

Leuchars' Mediæval Dressing-case.

Gentleman's dressing-case, of morocco leather, fitted with silver tops, engraved in a high style of art.

Travelling tea-equipage for two persons, in a morocco case. Morocco leather despatch-box writing-desk, of a new pattern, with a registered lock. Morocco leather sac de voyage, reticule, and other articles.

45 MECHL, J. J., 4 *Leadenhall Street*—Manufacturer.

Dressing-cases, work-boxes, writing-desks, tea-chests, and elegancies for presentation.

An ornamental dressing-case with handsome gildings and every requisite. This is represented in the cut (p. 793.)

46 HURRELL, W., 66 *Houndsditch*—Manufacturer.

Models of English oak vats.

47 HINE, JOSEPH, 5 *Skinner Place, Holloway*—Designer and Manufacturer.

Cabinet work of ebony, inlaid with various coloured pearls, tortoise-shell, &c. Writing-desk ornamented with various subjects and figures. Inlaid Regency desk. Inlaid work-boxes, with various-coloured pearls, tortoise-shell, &c. Buhl clock case, top supported by four pearl pillars, &c.

48 DALTON, THOS., 85 *Regent Street*—Inventor.

Combined writing-desk, dressing-case, and despatch box. Small dressing-case.

49 LUCAS, FRANCIS, 9 *St. John's Street Road, Clerkenwell*—Manufacturer.

Solid rosewood improved folding wing medicine chest.

50 ASPREY, CHARLES, 166 *New Bond Street*—Inventor, Designer, and Manufacturer.

Ladies' dressing-case, in a specimen of rare wood, surmounted with a new design, descriptive of Neptune's attributes, and a shield in centre, with name "Annie" in ciphers, entwined, the whole executed in chased and gilt ormolu. Secret compartments for sovereigns, notes, jewellery, &c. The fittings form a complete set in cut

glass, with massive silver tops, each bearing the same name. A set of ivory brushes, for hair, cloth, and velvet, and a pearl-mounted shoe-lift, poll and mouth glass, all bearing the same name in relief. The cutlery and other instruments, in white cornelian handles, mounted in gold, with the turquoise, &c., representing the "Forget-me-not;" and the linings of silk velvet. This dressing-case, with the inkstand and the ebony casket named below, are represented in Plate 17, p. 730.

Writing desk in tortoiseshell buhl, worked in an original design, emblematical of falconry; the interior arranged with various conveniences, and lined with sandal wood. Blotting-book, in silk velvet, with silk linings, surmounted with a new design, chased and gilt, in bold relief.

Casket, of new design, in gilt ormolu, and chased, having four allegorical figures representing Europe, Asia, Africa, and America, with a rare specimen of blood-stone, *en suite* with the blotting-book.

Stand, in chased ormolu, surmounted with ink-glass in artistic vase, with two figures blowing horns, forming a pen-rest and mounting a companion blood-stone, *en suite* with the preceding. Represented in Plate 17, page 730.

Ebony casket, of unique design, arranged with serpents upholding a choice collection of antique corals; the feet, handles, key, &c., being intricately worked out. Represented in Plate 17, page 730.

Jewel casket or cabinet, finished in or-molu, set with malachite, arranged with drawers and folding doors, pierced and chased in relief. This jewel cabinet is represented in the annexed cut (p. 793).

Casket envelope case, in chased work, gilt, ornamented with malachites, in pierced engraved mounts.

Blotting-book designed and mounted *en suite*. Inkstand and card and pen trays, designed and mounted *en suite*. Tazza candlesticks and taper stand, *en suite*.

Indicator, with rotary motion, showing the month, the days of the week, and dates at one view, designed, and mounted *en suite*.

Match box, designed and finished *en suite*. Ebony envelope box, conveniently arranged and surmounted with a new design, in flat, chased, and pierced work, gilt. Blotting-book, mounted and finished *en suite*. Writing-case, in red Russia leather, with inlaid handle and patent lock, engraved and gilt, with secret drawers, &c.

Plain morocco case, or carriage basket, combining a dressing case, with silver fittings, gilt inside, looking-glass, cutlery, &c., a writing-case fitted with stationery, blotting-book, pen and paper knife, penholder, pencil, paper, scissors, &c., a box with sandwich case, liqueur bottle and wine glass, knife, fork, spoon, &c., a brush-case, with set of brushes and combs complete, a jewel-case completely arranged, secret drawer for cash, account book, and journal, an ink-box with patent ink and light, trays, &c., arrangements for needlework, netting, and crochet, sketch book and pencils.

- 51 **JOHNS, GEORGE E.**, 3 *Aldermanbury*—Designer and Manufacturer.

Toilet box, and octagonal-shaped work-box, of English design, materials, and workmanship; manufactured of paper and embroidered satin.

- 52 **TURRILL, JOHN**, 52 *New Bond Street*—Manufacturer.

Portable writing-desk and receptacle for private papers and money.

- 53 **STURGEON, HARRIETT**, 180 *High Holborn*—Producer.
Vase of flowers, made from feathers, by an amateur.

- 54 **CLIVE, J. H.**, *Tunstall, Staffordshire*—Producer.
A ballistina and chest expander.

- 55 **LANGDALE, EDWARD F.**, 83 *Upper Thames Street*, and 52 *Frith Street, Soho*—Manufacturer.

Specimens of perfumes—extracts of millefleurs, violets, mignonette, patchouly, cassia, heliotrope, jasmin, fleur d'orange, and lavender. Samples of "essential oil of

brandy," "oil of pears," and "oil of pine apple," for distillation, flavouring confectionery, and summer beverages.

- 56 **DOWN, JOHN**, *Moat Row, Birmingham*—Designer and Manufacturer.

Wax fruit. Table of original design and manufacture.

- 57 **STIRLING, C. M.**, *Kippenross, Dumblane, Scotland*—Designer.

Impressions of single leaves by means of lamp-black and oil, representing, on a large scale, the peculiar growths of forest trees.

- 58 **ARTHUR, MARY S.**, *Glasgow*—Producer.

Vase of artificial flowers.

- 59 **JACKSON, ELIZABETH**, *East Bank Street, Southport*—Inventor and Producer.

Delicate vase of artificial flowers; the sole invention and work of the exhibitor, a fisherman's wife.

- 60 **PERRY, J.**, 1 and 2 *Victoria Place, Ramsgate*—Producer.

Vase of shell flowers.

- 61 **TEMPLE, EMILY**, 46 *Connaught Terrace*—Producer.

Wax flowers and foliage modelled from nature.

- 62 **SUGDEN, BORRAS, & Co.**, 12 *Aldermanbury*—Manufacturers.

Artificial flowers. Feathers for ladies' bonnets, and head-dresses of British manufacture.

- 63 **STRICKLAND, MARIA**, 8 *New Bond Street*—Manufacturer.

The "Victoria Regia," in its various stages of development, with each side of leaf modelled to nature. Roses, all copies from nature. Opal vase, filled with various flowers. Cut glass vase, with flowers. Model of the night-blowing *Cereus* and other Cacti. Variety of orchidaceous plants, &c.

[The *Victoria regia* is a water-lily of extraordinary beauty, inhabiting the still rivers of tropical America, where its seeds are eaten like maize. It first produced its flowers at Chatsworth, in 1849. They occupy two days in fully unfolding, and are deliciously fragrant. The leaves are so buoyant as to be capable of bearing the weight of a full-grown man and boy when standing on them.—J. L.]

- 64 **SLAUGHAN, ELIZABETH**, 37 *Gloucester Terrace*, *Cannon Street Road*—Producer.

Round shade filled with roses, imitated in wax, in an alabaster vase, entwined with wild and bower roses.

Four shades, with national motto in Forget-me-nots and rose-buds, modelled in wax; intended to be placed round the large shade of roses.

- 65 **RIDDIFORD, JANE**, 14 *Cowley Street, Westminster*—Designer and Manufacturer.

Group of hand-cut rice-paper flowers.

- 66 **RANDOLPH, WILHELMINA**, 55 *Marsham Street*, *Westminster*—Producer.

Specimens of plants and cut flowers, copied from nature; prepared with feathers of various hues, without dye or tinting; by an amateur.

- 67 **PURSEY, W. H.**, 14 *Spring Street, Sussex Gardens*, *Paddington*—Producer.

Imitations of flowers, cut in vegetables, and chemically preserved, for garnish.

- 68 **COX, JOHN**, *Georgie Mills, Edinburgh*—Manufacturer.

Samples of refined sparkling gelatine of various kinds, and glue.

Pair of safety swimming stockings, and safety swimming swan; to assist persons in escaping from shipwreck.

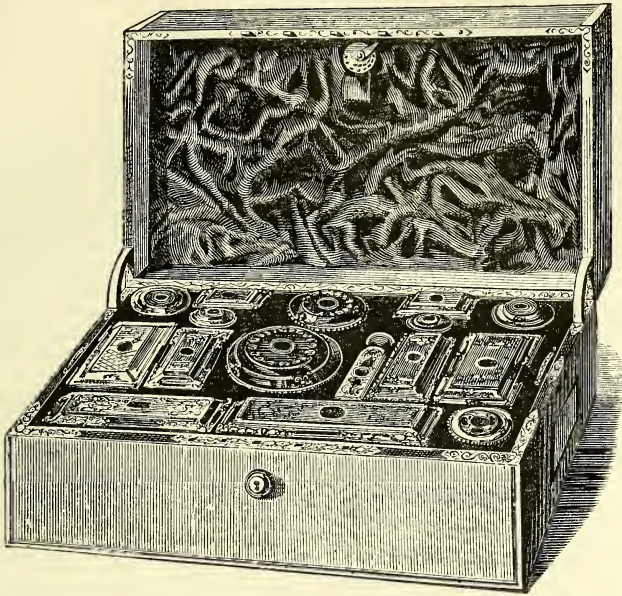

Mechi's Ornamental Dressing case.

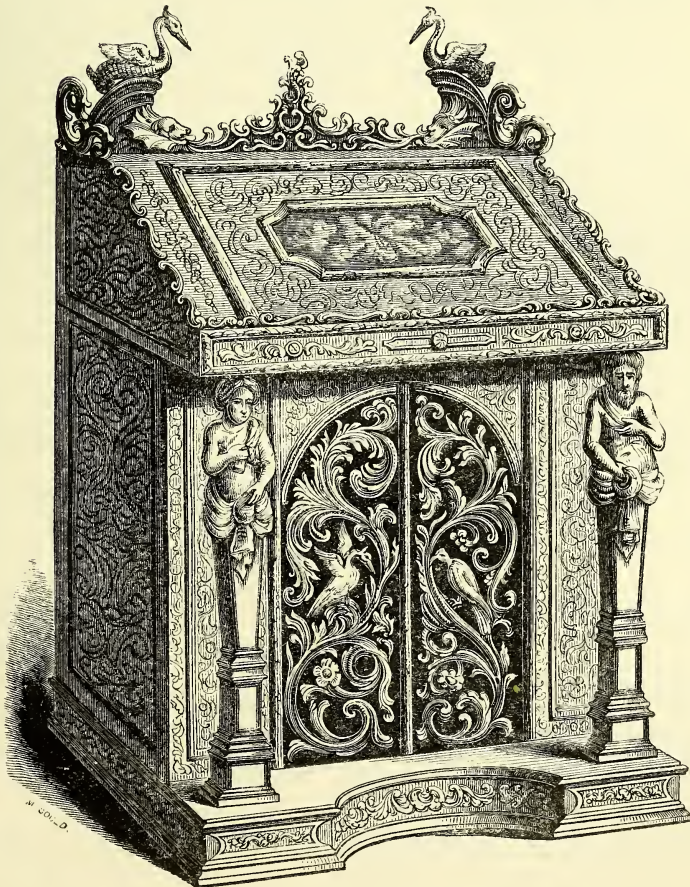

Asprey's Or-molu Jewel Cabinet.

NORTH TRANSEPT GALLERY.

- 69 BURCH & SON, 32 *Platt Terrace, St. Pancras*—Manufacturers.
An assortment of lead pencils.
- 70 MINTORN, JOHN H. HORATIO, ELIZABETH, and REBECCA, 36 *Soho Square*—Designers and Manufacturers.
Flowers modelled in wax, showing their applicability as ornaments for the drawing-room, &c.
Rare and curious botanical specimens modelled in wax from life, showing their growing state progressively.
- 71 MACUIRE, WM. JOHN, 5 *Chenies Street, Bedford Square*—Manufacturer.
Flowers made from dyed feathers, used for decoration.
- 72 HOSKINGS, ANN, 7 *Langthorn Place, Stratford*—Manufacturer.
Basket of wax fruit. Wax pastry and vegetables.
- 73 GATTI, AUGUSTINE & GASPARO, 28 *Bridge Road, Lambeth*; and 20 *Coppice Row, Clerkenwell*—Designers and Manufacturers.
Artificial cluster of sweet peas, made from white muslin and velvet, each piece shaded separately.
Flowers made of paper, and preparations for the same.
Patterns of articles used in making artificial flowers of British manufacture, comprising every colour and description of material.
- 74 FOSTER, SON, & DUNCUM, 16 *Wigmore Street*—Manufacturers.
Various specimens of the principal articles used in the manufacture of artificial flowers. Specimens of artificial flowers, in the different stages illustrative of the manufacture; in vases; and arranged as ornaments for the head dress, &c. Specimens of ostrich feathers. Muff and tippet, manufactured from the paddy or marabout feather.
- 75 EWART, HENRIETTA, *Bath Place, New Road, and Amphill Square, Hampstead Road*—Manufacturer.
Vases of wax flowers and plants.
- 76 POPE, W., *Bridge Street, Exeter*—Manufacturer.
Various specimens of felt, &c.
- 77 DORVELL, ELIZABETH, 199 *Oxford Street*—Inventor.
Wax flowers for ornaments, exhibited for tinting and modelling.
- 78 CHISHOLME, EMMA, 29 *Edward Street, Hampstead Road*—Manufacturer.
Specimens of wax flowers.
- 79 LEMARE, JANE CLARA, 11 *Cowley Terrace, North Brixton*—Manufacturer.
Sheets of wax for modelling flowers. The raw material, in three different stages. Also, a small group of flowers, showing the application of the waxen sheets.
- 80 FISHER, JOSEPH, 3 *Cripplegate Buildings*—Manufacturer.
Hawthorn or May-tree, and other British manufactured artificial flowers.
- 81 HARDING & STANDFAST, 83 *Hatton Garden*—Inventors.
Bonnet made of feathers, uniting warmth and lightness, and being at the same time porous and waterproof.
Artificial flowers of English manufacture.
- 82 JONES, ISABELLA B., 22 *St. George's Road, Notting Hill*—Modeller.
Group of wax flowers, from nature.
- 83 CALLOW & SON, *Park Lane*—Manufacturers.
A variety of gig whips.
- 84 SKILL, REBECCA, 79 *Warwick Street, Pimlico*—Inventor and Manufacturer.
Specimens of wax flowers. These are composed of chemical substances, resisting rough treatment, and enduring for a length of time. Basket of flowers; vase containing a bouquet; and a glass dish with water and plant. Specimens of the materials employed.
Three rustic ornaments in gutta percha.
- 85 MIERS, W. J., 15 *Lamb's Conduit Passage, Red Lion Square*—Manufacturers.
Specimens of ornamental letters.
- 86 FIELDER, MRS. GRACE, 11 *Upper Portland Place, Wandsworth Road*—Maker.
Group of wax fruit.
- 87 HOOL, MARY—Producer.
Flowers made of feathers.
- 87A GOING, J., & Co., *Clonmel, Ireland*—Manufacturers.
Pale yellow and white soap, exhibited for quality.
- 88 STANTON, MARY, 19 *Noel Street, Islington*—Manufacturer.
Wax flowers, in vases.
- 89 EDWARDS, THOMAS JEYES, 21 *King Street, Holborn*—Manufacturer.
Various dressing cases.
- 89A MITTON, T., *Penny Street, Blackburn*—Inventor and Manufacturer.
Fancy wax candles, for churches, &c.
- 90 BRIEN, C., *Dublin*—Manufacturer.
Clarified tallow candles.
- 91 DIXON, GEORGE, 1 & 2 *Upper Erne Street, Dublin*—Manufacturer.
Improved composite candles. Improved mould (tallow) candles, with waxed wicks. Household soap.
- 92 MORRELL, JOSEPH, *Darlington High Row, Durham*—Inventor and Manufacturer.
Marbled tallow candles, which burn without snuffing, and emit an agreeable perfume during combustion.
- 93 GALTON, MARY ANN, 56 *Upper Charlotte Street, Fitzroy Square*, and 26 *Hermes Street, Pentonville*—Designer and Manufacturer.
Sofrano standard rose-tree, mignonette. Modelled in wax.
- 94 MITCHELL, GRAHAM ALEXANDER, *Whitburn, Linlithgowshire*—Producer and Inventor.
Samples of vinegar, with a specimen of the plant which produces it.
Specimens of mineral candles.
Specimens of a chemical composition for preserving houses from damp.
- 95 JONES, W. HENRY, Rev., M.A., *Queen's College, Oxford, and Chailly, near Leves, Sussex*—Inventor and Patentee.
The acolyte; or patent safety candle-cap. The use of this instrument with lighted candles, while increasing the light and lessening the consumption, serves to prevent the waste and discomfort occasioned by their swaling or guttering, and overflowing, in draughts or motion. The acolyte is also available for carrying a shade.
The invention consists in the combination of a "cap" of metal (as a heat-conducting substance) regulating the supply to the wick, with a "guide" of glass (as a non-conductor of heat) maintaining its perpendicularity without communicating heat so as to melt the lower part of the candle; as exhibited in the cuts on the next page, in elevation and section.

In the commoner descriptions, suitable for dipped candles, a lining of plaster of Paris is substituted for the glass.

The acolyte thus formed, placed on a lighted candle, descends by its own weight as the candle burns, and may be used with the last remnant of a candle by the aid of a save-all of suitable size for it to pass over.

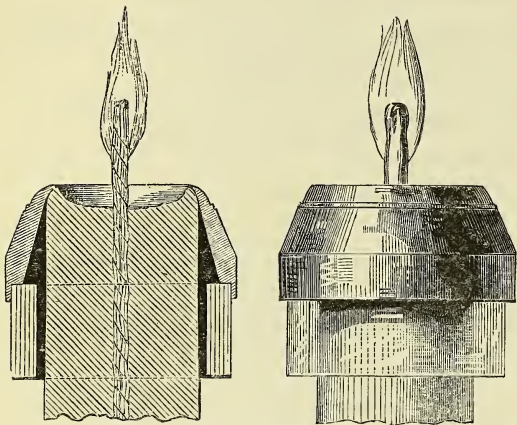

Jones's Patent Acolyte.

- 96 KIRBY, BEARD, & Co., *Depôt, Cannon Street, City*
—Manufacturers.

Pins, the head and shaft being all of one piece. Manufactured at Gloucester.

Needles; having pierced eyes; and fish hooks, suited for home or abroad, for river or sea fishing. Manufactured at Crendon, Buckinghamshire.

- 97 SANDELL, E., *Putney*—Inventor and Manufacturer.

Odoriferous lighters, for igniting tapers, lamps, &c., and refreshing the atmosphere of sick-chambers, nurseries, smoking-rooms, &c.

- 98 LEWIS, Miss, *Walthamstow, Essex.*

Paper-cuttings executed with scissors.

- 99 HALE, W. S., *73 Queen Street*—Manufacturer.

Specimen of stearic acid, and of the tallow from which it is made. Candles, manufactured from stearic acid, hard, and not affected by the heat of any climate. Composite candles, made from stearic acid of tallow and cocoa-nut oil. Boxes of night lights.

[Upwards of two million five hundred thousand poods of tallow are annually imported into Great Britain from Russia alone, which are devoted to the manufacture of soap and candles. Tallow candles, together with the more costly articles, wax and spermaceti candles, have been to a large extent re-placed by stearine candles. To M. Gay Lussac is due the credit of the application of philosophic chemistry in this instance to the humbler affairs of life. Stearine is prepared by repurifying tallow by means of lime, and then acting on the compound with dilute sulphuric acid. It is then compressed by hydraulic force, which expels the oily constituents of the tallow, and leaves behind a hard semi-crystalline substance; this is fused and run into moulds, and is then fit for use in the candle manufacture. A peculiar kind of wick is commonly used in candles made of this substance, and they do not require snuffing. Arsenious acid was formerly, and may possibly still be, introduced into stearine candles, with a view of promoting their solidification.—R. E.]

- 100 ROGERS & Co., *137 Strand.*
Baby-jumper.

- 101 BELL, R., *16 Basing Lane*—Manufacturer.
Samples of improved fuses.

- 102 GOWER, T., *Gun Lane, St. Stephen's, Norwich*—
Inventor and Manufacturer.
Lemonade, prepared from vegetable substances.

- 103 GRAHAM, LEMON, & Co., Producers.
Specimens of the process of the manufacture of lozenges and comfits, from the raw material to the finished state.
Samples of confectionery. Samples of plain, fancy double strong, and medicated lozenges, &c.

- 104 BOLAND, PATRICK, *138 Capel Street, Dublin*—
Manufacturer.
Various sorts of biscuits and cakes.

- 105 THWAITES, A. & R., & Co., *57 Upper Sackville Street, Dublin; and St. Alban's Place, Haymarket*
—Inventors and Manufacturers.
Soda water—"single," and "double." Introduced in 1800, by the late Robert Perceval, Esq., M.D., Professor of Chemistry in the University of Dublin.

- 106 WOTHERSPOON, JAMES, & Co., *Glasgow*—
Manufacturers.
Peppermint, lemon, rose, musk, lavender, ginger, and cayenne lozenges; comfits, almonds, carraways, and Scotch mixtures, made by patent machinery driven by steam power.

- 107 HUNTLEY & PALMER, *King's Road, Reading*—
Manufacturers.
Various fancy biscuits, made by steam machinery; the biscuits being mixed, rolled, cut out, and conveyed to the ovens without kneading the dough, as in the ordinary way.

- 108 LEALE & ALBRECHT, *4 Lichfield Street, Soho*—
Designers and Manufacturers.
Confectioners' cake moulds, in three parts, each formed from a single sheet of copper. Cake and jelly moulds of different designs. Jelly mould, designed and registered by Messrs. McManus, Temple, and Reynolds.

- 109 BEGG, WM. GORDON, *20 Market Street, Edinburgh*—
Inventor and Manufacturer.
Samples of lozenges and other confections, &c.

- 110 WILKEN, A., *6 Little Winchester Street, London Wall.*
Savoy cake ornamented with sugar.

- 110A LUCAS, G.—Manufacturer.
Lozenges and other comfits.

- 111 TIDMARSH, R., *3 Jamaica Row, Bermondsey*—
Inventor and Manufacturer.
Aromatic cachous, a small silvered pill or comfit, for producing an agreeable warmth and flavour.
Aromatic pastiles, for smoking.
Fumigating pastiles.

- 112 GUNTER, RICHARD, *Motcomb Street, and Lowndes Street, Belyrave Square*—Manufacturer.
Specimens of bride-cakes.

- 113 HUBBARD, H. B., *Baker Street, Enfield*—
Manufacturer.
Gingerbread nuts and gingerbread, said to keep for years.

- 114 SCHOOLING, HENRY, *7 North Side, Bethnal Green*—
Manufacturer.
Jujubes, of various flavours, and crystallized. Pastiles; mixed and ornamental confectionery. Chocolate sticks, drops, and cakes. Gelatine for printing, wrapping, and various other purposes.

- 115 WARRICK BROTHERS, 3 *Garlick Hill*—
Manufacturers.
Jujubes, lozenges, and other confectionery.
- 116 VINE, RICHARD, 10 *King Street, Borough*—
Designer and Manufacturer.
A bride-cake, ornamented with sugar icing by piping.
- 117 BURTON, H., *Hampstead*—Producer.
British insects, preserved.
- 118 RICHARDS, R., 21 *Tonbridge Place, New Road*—
Manufacturer.
Various fishing nets.
- 119 KEOGH, HENRY, 22 *Gilbert Street, Grosvenor Square*—
Designer and Manufacturer.
Composition set of dessert ornaments of eight pieces, in white and gold. Composition centre table ornaments in white and gold.
- 120 FARRELL, RICHARD H., 35 *Lamb's Conduit Street*—
Designer and Manufacturer.
Table ornaments for confectioners in plaster of Paris, gilt. Locomotive engine in wax. Church in wax, on a rock. Palm tree and elephant, on a rock, and giraffes, in grained sugar.
- 121 SPRATT, ISAAC, 1 *Brook Street, Hanover Square*—
Proprietor.
The game of "cockamaroo," improved. Model hay-cart.
- 122 MONTANARI, AUGUSTA, 29 *Upper Charlotte Street, Fitzroy Square*—Manufacturer.
Model wax dolls, the hair being inserted into the head, eyelashes, and eyebrows, and varying in size, &c.
- 123 LASCELLES, J. W., *Liverpool*—Producer.
Model of Mansion-house. Flies for fishing.
- 124 BOUCHET, A., 74 *Baker Street, Portman Square*—
Producer.
Animated and musical tableau, representing the Great Exhibition and people of all nations. Panoptic polyrama. Evening games. Knight in armour, complete, with horse caparisoned. Armorial trophies and Saracen armour. Balloon. Various mechanical toys. Dolls and shops.
- 125 BLACKMORE, MARY, 1 *Rosoman's Buildings, Islington Green*—Inventor and Manufacturer.
Artificial flower-plant, formed of beads strung on wire; intended as an ornament for the drawing-room.
- 126 SPURIN, E. C., 37 *New Bond Street*—Designer.
Mechanical toy model of an English farm, with figures, threshing-machine, windmill, &c., in action.
"Gulliver in Lilliput." Modelled by A. Fleishmann, of Sonneberg, near Coburg.
- 127 LUCAS, HENRY, 8 *Broad Court, Long Acre*—
Manufacturer.
Progressive garden rocking-horse.
- 128 DEAR, JOHN COX, 191 *Bishopsgate Without*—
Manufacturer.
Rocking-horse of wood, carved and shaped, with leather trappings and saddle to shift for boy or girl. Walking-sticks, carved.
- 129 SHORT, J., *Wallington, Surrey*—Manufacturer.
Essential oils of peppermint and lavender.
- 130 BEANEY, THOMAS, *St. Leonards-on-Sea*—
Manufacturer.
Assortment of arrows, inlaid by machinery, with foreign woods of various colours.
A kilee, or boomerang, similar to that used by the natives of Australia.
[The boomerang, or woomerang, is a weapon of offence, used by the aboriginal Australian. It is thrown from

the hand, not at the object intended to be struck, but into the air with a revolving motion, to a height of 60 or 80 feet, from which it descends upon the object to which it had been directed with the force of a falling body, which is generally, in the case of this weapon, sufficient to disable, if not to kill, whilst it is exceedingly difficult to watch its course and avoid the blow.—W. H.]

Registered duplex iron rest for a turning lathe, on a new principle.

- 131 HOLLAND, HENRY, *Darwin Street, Birmingham*—
Inventor and Manufacturer.
Umbrella frame; Holland's patent perlevis, expanded; weight, when covered, 9 ounces. This frame shows the action under the pressure of wind. The perlevis ribs, showing their elasticity; card, showing processes of manufacture; parasol perlevis frames.
- 132 STEARS, S., *Briggate, Leeds*—Manufacturer.
The "Princess Royal" parasol.
- 133 WILSON & MATHESON, *Candleriggs Street, Glasgow*—
Manufacturers.
New portable umbrellas, which can be folded up and put into a small bag, and the handle used as a walking-stick.
- 134 WADDINGTON & SONS, 1 *Coleman Street*—
Manufacturers.
Patent perlevis parasols and umbrellas.
- 135 SLARK, WILLIAM, 67 *Burlington Arcade*—
Manufacturer.
Improved umbrellas. Lady's parasol driving whip, made of ground rattan, very elastic; life-preservers, whips, &c. Lady's riding-whip made of India-rubber, mounted with gold and turquoise. Penang sword-cane. Steel foil covered with leather, forming a weapon of defence. Improved spare driving whip thongs. Ladies' and gentlemen's riding whips of improved mountings, sorted. Railway calls and dog whips.
- 136 SANGSTER, WM. & JOHN, 140 *Regent Street*—
Manufacturers and Patentees.
New patent parasol, so constructed that it can be closed by a slight pressure of the finger. The application of feathers as an ornament to parasols. Parasols covered with rich embroidered satins and guipure lace, carved ivory handles inlaid with gold and enamelled. Specimens of alpaca as applied to parasols and umbrellas—a new material, said to be more durable than silk. Holland's patent light silk umbrella.
- 137 RUTTER, JOHN & WILLIAM, 122 *Cheapside*—
Manufacturers.
Brown walking parasol. Brown glacé silk parasol, with jointed handle. Satin registered parasol; and a variety of others with ivory handles.
- 138 MITCHELL, J., *Stonehaven, Scotland*—Producer.
A variety of small wares.
- 139 OGLEBY, CHAS., & Co., *Paradise Street, Lambeth*—
Manufacturer.
Refined spermæceti in block, moulded in ornamental form. Stearo-margaric acid in block, similarly moulded. Candles manufactured from these articles.
- 140 MEYERS, BARNETT, 18 *Crutched Friars*—
Inventor and Manufacturer.
Specimens of ash, oak, blackthorn, crab, maple, cherry box, and of English oak, in their natural state. The same manufactured into walking sticks.
Ratans, imported from India, as from Calcutta, Singapore, Penang, Batavia. The same manufactured into umbrella and parasol cane ribs for milliners' use, cap-makers, whip and chair-makers, and brush-makers. A basket made of cane. A chair made of cane.

Carolina reeds from America; also reeds from Spain, &c. Canes from China, viz., white bamboos, black bamboos, whangees, doghead canes, fluted bamboos, jambes; from Singapore, viz., small ground ratans, large ground rattans, malaccas and dragons. Mottled bamboo fishing-rods, and jungle bamboo from Calcutta. Canes from Manilla.

Sticks from the British West Indies, viz., suple jacks, pimentas, cabbage plants, orange, lemon, coffee, Indian briars. A case of mounted canes in ivory, silver, gold, horn, &c.

A chimney-sweeping machine, made of malacca canes. Hunting whips, made of malacca and other canes.

A specimen of English watted crab, carved very curiously. Sword sticks and canes. Dart sticks and canes. Protectors. Portable stools. Registered mitred hook canes. Spring guard sword-sticks.

[Ratans and bamboo canes are the products of very different kinds of plants; the former being stems of species of palms, the latter of gigantic grasses. Both are furnished from tropical Asia. Ratans, dragons, and Penang lawyers are stems of various species of *Calamus*, climbing palms which hang from tree to tree like ropes, in the dense forests of the tropics, and bear beautiful pinnated leaves. Bamboos and whangees are the stems of various species of *Bambusa*, enormous arborescent grasses that grow to a height of from 50 to 60 feet. The joints of these stems are exactly of the nature of the knots on the stalks of European grasses. Reeds are also from grasses, especially the *Arundo donax* (Spanish reed). Pimentos are the wood of *Eugenia pimento*, the Jamaica pepper tree.—E. F.]

141 LEWIS & ALLENBY, 193, 195, and 197 Regent Street—Designers and Proprietors.

Parasol of novel construction, invented by J. Owen, and registered; its advantages are lightness and elegance (twelve very fine ribs, with stretchers proportionately small, being used, instead of the old number of eight of the usual thickness), and the new application of a pinked lining.

Parasol, exhibiting the application of coverings of Irish guipure lace, made at Clones, under the superintendence of Mrs. Hand.

Brocaded ribbons, designed by A. J. Lewis, manufactured at Coventry.

142 LINTON, W., *Belae*—Producer.

An assortment of fishing tackle.

143 CARPENTER, JOHN, 59 Church Street, Old Kent Road—Producer.

Walking-sticks, cut out of branches of trees of various descriptions and of natural growth, carved and engraved by an aged gardener, his tools being his pruning knife and a file for finishing off.

144 PORTER, W., *Northampton*—Producer.

Rocking boat.

145 PRESTON, RICHARD, 37 Highbury Vale, *Islington*—Manufacturer.

Walking-stick, manufactured from root of hornbeam (the *Carpinus betulus*, an amentaceous tree.)

146 BOSS, ISAAC ABRAHAM, 6 Bury Street—Inventor, Patentee, and Manufacturer.

A new patent parasol. By means of a new arrangement it is opened or shut in an easy manner.

Travelling umbrella, with connected folding handle, for the convenience of packing in a portmanteau. Skeleton frame, uncovered. Stiletto and frame.

Flush inlaid spring umbrella frame, with novel fastening of ribs, stretchers, open cap, &c., avoiding rivets.

Skeleton frame of the patent parasol, intended to exhibit the application of its principles of construction to various designs.

All made in metallic ribs, German silver, and other tubing.

147 HARGRAVE, HARRISON, & Co., 13 Wood Street, *Cheapside*—Inventors and Manufacturers.

Registered cycloidal parasols; the projecting points of other parasols are avoided: an increased shade is afforded with a smaller and lighter frame-work.

148 EVANS, T., & Co., 10 Wood Street, *Cheapside*—Manufacturers.

Specimens of parasols.

149 FOSTER, PORTER, & Co., 47 Wood Street, *Cheapside*—Manufacturers.

Specimens of parasols.

150 MUIR, PETER, *Archer's Hall, Edinburgh*—Manufacturer.

Specimens of bows, arrows, &c., manufactured of Italian yew, English and Irish bog yew, Scotch yew, snakewood, palm, fustic washaba, lance, and Canadian elm.

151 HORE, WALTER, *Harperstown, Tughmon, County Wexford, Ireland*—Inventor.

Trigger to a long bow, larger than the lock of a pistol.

152 PARKINS, T., *Carlisle*—Manufacturer.

Fish-hooks, artificial flies, minnows, &c.

153 ROWELL, J., *Carlisle*—Manufacturer.

A four-joint fishing-rod, with hollow butt, two tops, and appendages for trout-fishing; with specimens of raw materials for making. Fish-hooks in the various stages of manufacture, from the raw material. Artificial flies for salmon and trout fishing. A variety of tackle for angling, with the minnow and other baits, for trout and pike, or jack.

154 NICHOLAS, MARTHA, 58 Castle Street, *Carlisle*—Inventor and Manufacturer.

Case of artificial flies and baits used in angling. Exhibited for superiority of workmanship, and near resemblance to nature.

155 THE NORTHUMBERLAND PATENT TWINE, ROPE, and NET COMPANY, *Newcastle-upon-Tyne*—Manufacturers.

Samples of herring, trout, and mackerel nets, braided or meshed by machinery; of twines, made and spun by machinery; of fishing strings and lines; and of rope, spun-yarn, marline, &c.

[The following Statistics of the Herring and Cod Fisheries are drawn up by Mr. John Millers, General Inspector of Fisheries in Scotland, and communicated by Captain Washington, R.N., F.R.S. The official Report of the Herring and Cod Fisheries on the coasts of Great Britain, for the year 1849, affords the following statistics, which may serve to show the importance of this branch of national industry.

Number of vessels and boats employed	14,692
Tonnage	214,858
Number of men and boys in the boats	59,792
Number of persons employed curing, packing, exporting, &c.	46,254
Grand total to whom the fishery gives employment	106,046

Wages of men vary from 12s. to 15s. a week. Value of a first-class open boat complete, 100*l.*; with 25 nets complete, 100*l.*; set of lines, 23*l.*: total 223*l.*

The capital embarked in the fisheries is as follows:—

	£.
Value of boats, nets, and lines employed	1,189,090
Capital embarked equal to one year's produce	2,191,325
Capital invested on shore in curing places, &c.	2,191,325
Value of 81,791 tons of shipping, at 9 <i>l.</i> per ton, employed in carrying	736,119
Grand total invested	6,307,859

Except in short spaces the herring fishery is prosecuted around the whole coasts of England and Scotland. The length of the season varies, but may be considered from the middle of May to the beginning of March.

The produce of the herring fishery in 1849 was, in barrels	1,151,979
The produce of the cod fishery was	381,778
Total produce in barrels	1,533,757

Computed weight, allowing seven barrels to the ton, 219,108 tons.

Local consumption and home market dispose of 1,093,501 barrels.

Foreign consumption, 440,256 barrels.

Price of cured fish 20*s.* a barrel, chiefly consumed by the poor.

Estimated average value of the fish caught, 2,191,325*l.*

Largest number of fish taken at one haul, 120 barrels.

A single boat in one season has caught 1,000 barrels, and nightly spreads nets to the extent of 21,000 square yards. A crew of eight men in the cod fishery use 7,680 yards of line with 6,400 hooks.

The quantity of netting set each night (for five nights each week) and hauled every morning was 94,916,584 square yards, equal to 19,640 acres, or to 36 square miles. These nets when set extend over a space of about 6,000 lineal miles, and are, therefore, from seven to nine yards deep in the sea. The boats daily traverse about ten times the above space in proceeding to the fishing ground, setting and hauling the nets, and then returning to port. Thus in one week the distance sailed by the British herring and cod boats exceed 300,000 miles.

The length of fishing-lines and buoy-ropes daily used is 36,313,706 yards, or 20,632 miles, which would nearly reach round the globe.

In the district of Wick, Caithness, the netting daily set and hauled by 800 boats would extend in a straight line to about 590 miles, or would reach from Caithness to the island of Heligoland. Yet on this coast, for 12 miles in extent, there are only three small tidal harbours, inaccessible at low water or with an easterly gale, and distant 50 miles from a safe anchorage; while the value of the boats and nets at sea every night for three months in the year is 150,000*l.*, no part of which is insured, and all the property of poor fishermen, the greater part of whom are not even members of the Shipwrecked Fishermen's Benevolent Society. It would be a public benefit were the Mercantile Marine Act extended to fishermen as well as seamen, for as a class there are none more exposed, none undergo greater hardships, none more improvident, and none more thoughtless of the future.]

156 FLYNN, W., Worcester—Inventor.
Flexible baits, for salmon, trout, &c.

157 ALLIES, FREDERICK, Worcester—Inventor and Manufacturer.

Artificial baits—Archimedean minnow, variously leaded and mounted, viz.: gudgeon size, pike; small gudgeon size, salmon and pike; large trout and salmon size; and small trout size. Also, pectoral fin minnow, variously leaded and mounted, viz.: gudgeon size, pike; small gudgeon size, salmon and pike; large trout and salmon size; and small trout size.

158 DAVIDSON, G. & W., 17 Quay, Aberdeen—Manufacturers.

Model of Aberdeen salmon bag-net, used for catching salmon in the sea.

159 KELLY & SON, 56 Lower Sackville Street, Dublin - Manufacturer.

Fishing tackle; artificial flies, &c.

160 BANIM, MICHAEL, Kilkenny, Ireland—Inventor and Manufacturer.

Amateur fly-angler's cabinet, made of Irish bog-yew, containing materials, methodically arranged, for making imitations of aquatic insects; accompanied by an essay on the characteristics of fresh-water ephemera, exemplified by specimens of the manufactured fly.

161 DENNIS, Rev. J. B. P., Bury St. Edmunds—Producer.

Stuffed birds:—Peacock, with train spread, copied from nature; small gull, showing a method of giving a natural lustre to the eye and eyelids, and restoring the rosy tint of the underneath plumage.

162 M'NAIR, J., Tillicoultry, Alloa, Scotland—Manufacturer.

Fishing-rods, exhibited for superiority of execution.

163 PULMAN, G. P. R., Crewkerne—Manufacturer.

Artificial-flies, for river fishing.

164 NICHOLLS, WILLIAM, Chippenham—Producer.

Fluid extract of annatto, &c.

[Annatto is prepared from the seeds of the *Bixa orellana*.

It is used as a colouring substance.—E. F.]

Samples of Beaufort Hunt sauce.

165 MORLEY, JOHN, Nottingham—Producer.

New artificial flies, intended, when in use in the water, to preserve their form. Solid plaited taper hair-lines, made of hair and silk. Fishing-tackle of various kinds.

166 HARDING, G. P., 83 Hatton Garden—Manufacturer.

Cases of feather bonnets of novel manufacture, uniting lightness with warmth and porousness, in every variety of colour.

167 REMMIE, Misses, 20 New Ormond Street, Bloomsbury—Designers and Manufacturers.

Three ornaments for table or cabinet; bride-cake ornament; regal chair, formed from a portion of a turtle bone; and basket in imitation of Dresden china. All in composition of gum.

168 HARMER, H. R., Great Yarmouth—Producer.

Net for keeping fish alive when angling or trolling from a boat or bank.

169 HARVEY, H., King's Head Court, Barbican—Producer.

Samples of sauce.

170 DANIEL, T., Burslem, Staffordshire—Producer.

Subjects cut in paper, by Mrs. Thomas Daniel.

171 GOULD, ALFRED, 36 St. Marylebone Street—Manufacturer.

Fishing rods and tackle on improved principles.

172 **USTONSON & PETERS**, 48 *Bell Yard, Temple Bar*—
Inventors.

Bamboo cane fly and salmon fishing-rod. Each joint is formed of three triangular parts, connected together from end to end. Box of artificial angling baits, including rare specimens of flies and insects, silkworm gut, taper fly line, &c.

173 **PEARCE**, T. B.—Manufacturer.
Specimens of fishing tackle.

174 **LITTLE, GILES, & Co.**, 15 *Fetter Lane, Fleet Street*—
Inventors and Makers.

Superior fly rod, ornamented in silver; relieved with gold, with various improvements. Improved cane boat or punt-rod, ornamented in gold. Salmon rods; winches; fly and dubbing books, with tackle and flies.

175 **BUCHANAN, J.**, 191 *Piccadilly*—Manufacturer.

Three bows of yew wood, cut from the Alps; the first brought to this country. A variety of bows and arrows.

176 **FARLOW, C.**, 221 *Strand*—Manufacturer.

Fishing rods, tackle, and cases; with various artificial baits and insects.

177 **BERNARD, JOHN**, 4 *Church Place, Piccadilly*—
Manufacturer.

A variety of fishing rods and tackle.

178 **BAZIN, GEORGE**, 110 *Old Street, St. Luke's*—
Manufacturer.

Assortment of taper quill floats for angling.

179 **ALFRED, WILLIAM HENRY**, 54 *Moorgate Street*—
Manufacturer and Proprietor.

Complete set of highly-finished fishing tackle.

180 **AINGE & ALDRED**, 126 *Oxford Street*—
Manufacturers.

Bows, arrows, and archery accoutrements, of various patterns and designs. Fishing rods and tackle.

181 **FARLOW, JOHN KING**, 5 *Crooked Lane, City*—
Manufacturer.

Salmon rod, winch lines, flies, hooks, &c., and all necessary gear for salmon fishing. Grilse or sea-trout rod, with the necessary tackle. Fly rod, with tackle complete. General rod, for fly-fishing, trolling, and bottom fishing, with the requisite tackle and fittings. Spinning and trolling rods, with tackle complete, artificial bait, &c.

182 **JONES, JAMES**, 111 *Jermyn Street, St. James*—
Manufacturer.

Specimens of fishing rods and tackle.

183 **JACOBS, GEORGE**, 32 *Cockspur Street*—Inventor.
and Manufacturer.

English long bows for ladies and gentlemen, composed of different rare woods, viz., rosetta, tulip, snake, partridge, rose, purple, kingwood, and hickory. English and Flemish long bows. Collection of English arrows of various weights and woods, with quivers and accoutrements.

The registered protector umbrella. The novelty consists in unscrewing and retaining the handle, which renders the umbrella useless to any but the owner.

Strangers' guide map, showing all the principal streets, bridges, railways, and exhibitions of London, together with a mariner's compass. The map can be inserted in umbrellas, riding-canes, walking-sticks, &c.

Fine specimen of Malacca cane, mounted in basso-relievo. Dragon canes mounted; and tortoiseshell walking-stick mounted in gold.

Specimen of rhinoceros' horn and of sea-horse's tooth. Collection of English sticks of natural growth, in the rough and finished state.

184 **JEFFERIES, ISAAC**, 40 *Mulgrave Place, Woolwich*
—Manufacturer.

Improved tennis racquets. Irish shaped racquets. English shaped racquets. Racquet and fives balls.

185 **LOCAL COMMITTEE**, *Falmouth and Penryn*—Producer.

Preserved pilchards. Model of pilot-boat, built by R. Lee, Falmouth. Model of Falmouth river barge, and of the new Mevagissey drift and fishing-boat, made by Richard Treginza. Model of Seine boat, built by P. Lelean, Mevagissey. Nets used in the Cornish fisheries. Apparatus for extracting pumps from mines which are filled with water; invented by Arthur and Edey. Reversing apparatus, &c.; inventor, Mr. R. Hosking, of Perron Foundry.

186 **CLAPSHAW, MARK**, *High Street, Eton*—Manufacturer.

Bats, stumps, balls, pads, gloves, and gauntlets, for the game of cricket.

187 **GILBERT, WM.**, *Rugby*—Manufacturer.

Foot-balls of leather, dressed, ornamented, and coloured.

188 **LAMBERT, ELEANOR**, 89 *Leman Street, Goodman's
Fields, Whitechapel*—Manufacturer.

Specimens of artificial flies, for angling.

189 **CLEMENTS, J.**, *Leicester*—Inventor and
Manufacturer.

Newly invented bat for cricket playing, having a piece of whalebone let down the centre of the handle to make it flexible.

190 **MASSEY, W. A.**, 41 *Sir Thomas's Buildings, Liverpool*
—Producer.

Pair of bowls and jack, representing the English game of bowling. The stand or pedestal is a specimen of oval turning.

191 **DUKE & SON**, *Penshurst, near Tonbridge, Kent*—
Manufacturers.

Articles used for the game of cricket, comprising balls, bats, stumps, leg-guards, gauntlets, tubular India-rubber gloves, spiked soles, &c.

192 **GOURLAN, J.**, *Edinburgh*—Manufacturer.

Specimens of balls for playing the ancient Scottish game of "Golf."

193 **PEACOCK, ANTHONY**, 2 *Cumberland Row, Islington*—
Inventor.

Board and pieces, for playing the game of Agon, or the Queen's guards; with book of instructions.

194 **PAGE, ELEANOR & WILLIAM**, *Kennington Common*
—Manufacturers.

Cricket bats. Gauntlets, for keeping wicket. Tubular India-rubber gloves, leg-guards, cricket balls, cricket stumps, brass ferruled, and ash topped. Spike soles, for cricket shoes.

195 **MEDWAY, JAS.**, 134 *St. John Street, Smithfield*
—Designer and Manufacturer.

Cricket stumps constructed on a novel and simple principle; the three upright pieces move upon rule joints, which, upon the slightest blow from the ball, fall instantaneously in whatever direction they may be struck. Registered.

196 **LILLYWHITE & SONS**, 10 *Prince's Terrace, Islington*—
Inventors and Manufacturers.

Cricket bats, of superior wood. Cricket balls. Wickham's trap balls. Set of Allen's stumps. Leg-guards, on a new design, for preventing the ball (when bowled) from injuring the leg. One pair made of leather, which material has always been used. Tubular galvanized India-rubber gloves. New wicket-keeping perforated gloves. Spiked soles. Scoring booth on a new principle.

Flannel dress, comprising a pair of trousers, jacket, cap, and belt.

197 **DARK, MATILDA, & SONS**, *Lord's Cricket Ground,
St. Marylebone*—Manufacturers.

Cricket bats and wickets.

198 DARK, ROBERT, *Lord's Cricket Ground*—Inventor and Manufacturer.

Articles used in the game of cricket; tubular India-rubber gloves; gauntlet gloves; leg guards; spiked soles for shoes; cricket balls of varied sizes.

199 CALDECOURT, WILLIAM HENRY, 14 *Townsend Road, St. John's Wood, Marylebone*—Manufacturer.

Cricket catapulta, a machine for propelling the ball in the absence of a first-rate bowler. Cricket bats, and sets of stumps.

200 TREBECK, THOMAS FREDERICK, 3 *Sun Street, Bishopsgate Street*—Proprietor.

A variety of rocking-horses, dolls, and miscellaneous toys.

201 GOING, J., *Clonmel, Ireland*—Producer.

Specimens of various soaps.

202 GORDON, C., *Museum, Dover*—Manufacturer.

A group of stuffed British birds, representing an owl surrounded by small birds.

203 HARBOR, THOMAS, *Reading*—Manufacturer.

British specimens of taxidermy, viz. :—Mute swan (*Cygnus olor*), attracted by teal (*Anas creca*); common buzzard (*Falco buteo*); clutching leveret; hobby hawk (*Falco sub-buteo*) attacking partridges and young (*Tetrao perdix*); pair of landrails and young ones (*Gallinula crex*); bearded titmouse, male and female (*Parus biarmicus*); pair of kingfishers (*Alcedo ispeda*); pair of grossbeak (*Lovia coccothraustus*); case of pheasants (*Phasianus colchicus*); polecat (*Mustela putorius*); and rabbit.

204 BEEVOR, J. (M.D.), *Newark-upon-Trent*—Inventor.

An improved process of taxidermy, or stuffing of animals, illustrated by a noted foxhound from the Rufford hunt. This is effected by the use of gutta percha, by which a complete muscular model of the animal is taken after the removal of the skin. The skin being replaced, an exact resemblance of the animal, with the points fully developed, is produced.

206 RETTERAY & THOMPSON—Manufacturers.

Specimens of fishing nets.

207 WALFORD, C., sen., *Witham, Essex*—Preserver.

A series of preserved British birds—common barn owl, common brown owl, long-eared owl, spotted woodpecker, cuckoo, pair common swallows, pair house martens, fly-catcher (spotted), grasshopper warbler, redstart, hedge warbler, mountain finch, bullfinch, red linnet, and house sparrow.

208 YERBURY, J., 114 *Bishopsgate St. Within*—Proprietor.

Staité's patent diaphragm tobacco-pipe bowl for condensing and collecting the essential oil and moisture of the tobacco. The specimens exhibited are manufactured in stone china by Messrs. Josiah Wedgwood and Sons.

209 THOMPSON, HENRY, *Weybridge Common, Chertsey, Surrey*—Inventor and Manufacturer.

Imitative cameos, the small ones used for wafers. Gold and silver wafers.

210 BRINDLEY, J., *Milk Street, Bristol*.

Small cask of peculiar construction.

211 REED, J. W., 11 *Peel Place, Kensington*—Producer.

Stick in glass case, with gilt edge; the stick black, the two snakes yellow.

212 WALFORD, J., *Witham, Essex*.

Stuffed birds.

213 BARSHAM, SON, & Co., 41 *Threadneedle Street, and Stratford*—Manufacturers.

Specimen of pulped cloth, being a combination of paper, in a state of pulp, with a woven fabric.

Emery cloth, being an application of the pulped cloth, as a more durable substance than paper alone; used for the purpose of smoothing and polishing metals and machinery.

Glass cloth, a further application of pulped cloth as a more durable substance than glass paper; used by wood-turners, carvers of wood, carpenters, and others.

Glass paper, used principally by cabinet makers for smoothing the surface of wood.

Emery in a manufactured state, as used by engineers, lapidaries, and others for polishing metal, glass, &c. Manufactured from Naxos emery stone.

Black lead, manufactured from the raw substance so called, imported from Germany; used principally in England for giving lustre to stoves and grates.

Patent framed door-mat.

214 SACKER, FRED. CHRISTIE, 7 *Epping Place, Mile End*—Designer.

Compendium, or razor-strop, the strop itself being formed of a composition of wool; the interior containing two razors, tooth-brush, nail-brush, comb, scissors, tweezers, nail-file, looking-glass, shaving-brush, and soap.

215 ROGERS, ROBERT & HENRY, *Prospect Row, Walworth*—Manufacturer.

Specimens of glass, emery, and sand papers and cloths.

216 BURSILL, E. & CLARA, 9 *York Terrace, Queen's Road, Hornsey Road*.

Compressible toys.

217 AUSTIN, W., *Crowhurst*.

A foot-stool.

218 SHARP, J., *Halton, Bucks*.

Specimens of carvings.

219 WILLIAMS, THOMAS MUTLOW, 155 *Oxford Street*—Producer.

Case of stuffed birds.

220 FISHER, J., *Blandford*—Manufacturer.

Specimens of wire buttons.

221 LEADBEATER, JOHN, 19 *Brewer Street, Golden Square*—Manufacturer.

Case of mounted Indian game birds; case of mounted birds under glass shades. Shade said to contain the largest specimen of the toad and the least species of dog.

222 SPENCER, THOMAS, 7 *Great Portland Street*—Inventor and Producer.

Preserved birds, on artificial frost and snow, with water and a rock.

223 GARDNER, JAMES, 426 *Oxford Street*—Preserver.

Various specimens of stuffed birds; one half being birds of prey, indigenous to Britain, and the other showy-plumaged birds.

224 ANDERSON, RODERICK, *Dunheld, Scotland*—Manufacturer.

Artificial salmon-flies, adapted for the river Tay and its tributaries.

Artificial trout-flies, for the lakes and rivers of Scotland.

225 FISHER, EDWARD, *St. Mary's, Wisbech*—Inventor and Producer.

Models of five stacks, to show a new mode of covering them with wood, iron, zinc, &c.

- 226 SLATER, JOHN, *Cheadle, Staffordshire*—Inventor and Manufacturer.
Twine reel, used by drapers, druggists, grocers, &c.; made of brass and lacquered.
- 228 DAUBARN, W., *Wisbech*—Manufacturer.
Specimens of reel and ball sewing cottons.
- 230 QUIN, JAMES, *Kidderminster*—Inventor, Designer, and Manufacturer.
Specimens of combed wool, in white and of various colours.
Gothic bird-cage, cut out of the wood.
Lathe, on a new plan, for foot wood-turning, the man sitting to his work.
Wood carpet-shuttle, with steel noses, on a new plan.
Carpet-shuttle, copper, with wood noses, a new invention.
Parasol-frame, to be opened by pressing in the ferule.
- 231 CHAMBERLAIN, THOMAS, *Ashby-de-la-Zouch, Leicestershire*—Manufacturer.
Stones for burnishing all kinds of plate and gilded work, both in the rough and prepared state.
- 232 MOORE, GEORGE, & MURPHY, MICHAEL, 116 & 117 *Holborn Hill, and King's Cross*—Inventors and Manufacturers.
Specimen of an ornamental wedding cake.
- 234 DUNBAR, WILLIAM, *Loch Inver, Golspie, Scotland*—Proprietor and Preserver.
Two cases of Sutherlandshire wild birds and animals: containing a roebuck, a common hare, two mountain hares, two wild rabbits, three grey partridges, two woodcocks, a common snipe, a jack snipe, two golden plovers, three common pheasants, and one pied, two black cocks, two grey hens, five red grouse, male and female; twelve ptarmigans, male and females, in their spring, summer, autumn, and winter plumage. The golden eagle—mature female.
The majority were killed, and all were stuffed, by the exhibitor.
- 237 BROWN & SON, *Leeds*—Manufacturers.
Cotton bobbins and skewers. Flax bobbins, creel pins, and box-wood bosses. Worsted bobbins, spools, and carrying rollers. Silk bobbins.
- 239 STANDRING, JOHN, & BROTHER, *Manchester*—Manufacturers.
Braids, in gold, silk, mohair, worsted, and cotton, for trimmings and other purposes. Laces, in silk, worsted, and cotton, for corsets, dresses, and boots. Lines, plaited, in silk, worsted, linen, and cotton, for window blinds, pictures, &c. Dress cord plaited cotton, for stiff dresses. Bindings, figured and plain, in silk, mohair, and worsted, for coat bindings, &c. Fringes, in silk and cotton, for trimmings.
- 240 FLETCHER, HENRY, 8 *Swan Court, Manchester*—Inventor and Manufacturer.
Sheet of glass having brass letters and ornaments firmly attached.
Brass or zinc engraved plate, filled with a composition to resist the heat of the sun.
- 242 HALL, JOHN, *Green Gate Street, Oldham*—Designer and Inventor.
A bird-cage, containing 2,522 pieces, and composed of 21 different kinds of wood. In the front is the Oldham coat-of-arms, and on the right side, a representation of the Sailors' Home, Liverpool.
- 243 BELL & BLACK, 15 *Bov Lane*—Manufacturers.
Imitation vests and congraves, without any combustible material.
Machine, with knife inserted, for cutting the matches in half.
Manufactured wax vesta matches.
Camphorated round wood congraves, which burn with an agreeable odour.
- 244 FLETCHER, W., *Burnham, near Bridgwater*—Manufacturer.
Working models of filtering vessels. Model of Burnham lighthouse. Specimens of amber, jets, &c., found on the coast of Norfolk, polished.
- 245 COWPER, EDWARD, F.R.S., 9 *Kensington Park Road, Notting Hill*—Inventor and Patentee.
Cheap educational models. An orrery. Section of a pump. Working parts of a steam-engine. Globe, showing the phases of the moon. Box of cubes. Measuring rods. Levers. Working loom. Door lock.
- 248 MORELL, H., 149 *Fleet Street*—Manufacturer.
Specimens of the manufacture of lead pencils.
- 250 WRIGHT, HENRY, *Belview Steam Mills, Dublin*—Manufacturer.
Buttons made from bone, horn, and wood. Bone handles for knives and forks, and for tooth and nail brushes. Bone knives and forks for lunatic asylums. Neats-foot oil. White cow hair, used in blanket making. Brown cow hair, used by felt-makers, for ship sheathing, &c. Gelatine and portable soup. Farina, prepared from potatoes. White and yellow Indian corn meal. Beet-root sugar. Bone-dust for farmers' use.
- 252 STAIGHT & SONS—Manufacturers.
Specimens of manufactures from ivory.
- 253 ILIFF, W. T., *Newington*—Producer.
"London street scenes," "May day," &c., modelled (by the hand) from gutta percha, by Miss E. Moorsom, of Kennington, aged 13.
- 257 BRISON, R., *Bristol*—Inventor and Manufacturer.
Models of feet, made of a material that will bear nailing or hammering, on which boots or shoes can be made.
- 259 RITCHIE, JAMES, *Canongate, Edinburgh*—Manufacturer.
Sash-line with metallic centre to increase its strength, metallic cord for the balance-weights of gas-lustres; cord for hanging pictures and for bell-pulls.
- 261 EARNSHAW, R. J., *Doncaster*—Manufacturer.
Wool sheets or top sheets, for packing fine combed wool, called "tops;" hand-spun and hand-woven, from fine hemp, and lined with calico.
- 262 NAPIER, JOHN, *Edinburgh*—Inventor.
Pair of printing cases, full size, in one-third less space than those in general use; bevelled, or at an angle, instead of square.
Model of a heating or cooling apparatus for rooms. By filling the inside cylinder with hot water or steam, and turning the cylinder, the fan will throw off the heat, and consequently raise the temperature. If any of the common freezing mixtures be placed inside the cylinder, on its being turned round, cold air will be thrown off and the temperature lowered.
A method of turning up quickly books of the Bible, or chapters of other books.
A method of ornamenting end wood, for cabinet, joiner, and other work, mouldings, &c.
- 266 WANLESS, THOMAS, *Rock, near Alnwick, Newcastle*—Manufacturer.
Lady's pincushion and piercers.
Swing plough, constructed to prevent dirt or soil attaching to the mould board.
- 267 DOWN, STEPHEN, *Ivythorn, near Glastonbury*—Designer.
Model of a decoy pool, for taking wild fowl.

NORTH TRANSEPT GALLERY.

270 LIVERPOOL LOCAL COMMITTEE, *Town Hall, Liverpool*—Proprietors; J. C. ARCHER, Collector and Arranger.

A Collection of the Samples of Foreign Articles Imported into Liverpool within the last Five Years. The Collection is complete as to Vegetable Fibres, Materia Medica, Groceries, and Mineral Products; incomplete as to Perishable, Animal, and Vegetable Products, and Manufactured Goods.

[N.B.—Articles marked thus (*) in the last column are rarely imported, and in comparatively insignificant quantities.]

CASES 1, 2, 3.—CLASS A. ORGANIC SUBSTANCES. Section 1. ANIMAL PRODUCTS.

Subsection 1st, Mammalia.

COMMERCIAL NAME.	Scientific Name, or Designation.	Class or Order.	Whence Imported.	Uses, &c.	Imports, 1850,
Deer horns	<i>Axis maculata</i> . .	Ruminantia . .	East Indies . .	Knife handles and other articles.	250 tons.
Buffalo horns	<i>Bos Bubalus</i> . . .	Ruminantia . .	East Indies . . .	Buttons, knife handles, &c.	280 tons.
Buffalo horn tips . . .	<i>Bos Bubalus</i> . . .	Ruminantia . .	East Indies . . .	Buttons, &c.	120 tons.
Buffalo horn shavings . .	<i>Bos Bubalus</i> . . .	Ruminantia . .	East Indies . . .	Making gelatine, &c. .	*
Ox and cow horns . . .	<i>Bos Taurus</i>	Ruminantia . .	Monte Video . . .	Knife handles and various articles.	700 tons.
Porcupine quills . . .	<i>Hystrix cristata</i> . .	Rodentia	Barbary	Various ornamental purposes.	*
Ivory, or elephants' teeth	<i>Elephas Africanus</i>	Pachydermata	W. Coast of Africa	Various ornamental purposes.	31 tons.
Sea-morse teeth (erroneously supposed to belong to the sea morse).	<i>Hippopotamus amphibius</i> , or probably <i>H. Liberiansis</i> .	Pachydermata	W. Coast of Africa	Making artificial teeth, &c.	2½ tons.
Horse tails (3 varieties)	<i>Equus Caballus</i> . .	Pachydermata	Buenos Ayres, &c.	Stuffing cushions, &c..	430 bales and bags.
Horse hair	<i>Equus Caballus</i> . .	Pachydermata	Buenos Ayres, &c.	Stuffing cushions, &c. .	80 tons.
Cow-tail hair and cow hair.	<i>Bos Taurus</i> (male and female).	Ruminantia . .	Monte Video, &c..	Stuffing cushions and mixing with lime for mortar.	170 tons.
Alpaca wool (5 varieties)	<i>Auchenia alpaca</i> . .	Ruminantia . .	Lima, Chili, &c. . .	Making fine cloths. . .	900 ballots or small bales.
Vicunia wool	<i>Auchenia Vicunia</i>	Ruminantia . .	Lima	Making fine cloths. . .	300 ballots.
Llama wool	<i>Auchenia Llama</i> . .	Ruminantia . .	Lima	Making fine cloths, and for mixing with Alpaca wool.	1,100 ballots.
Camels' hair (2 qualities)	<i>Camelus Bactrianus</i> .	Ruminantia . .	Cairo and Alexandria.	Weaving into cloth, making paint brushes, &c.	25 tons.
Goats' wool (Cachmere)	<i>Capra ægargus</i> . . .	Ruminantia . .	Turkey.	Weaving fine cloths, shawls, &c.	200 bales.
Goats' wool (mohair) . .	<i>Capra ægargus</i> . . .	Ruminantia . .	Turkey.	Weaving fine cloths, shawls, &c.	200 bales.
Sheep's wool (47 varieties, classified under the heads Russian, German, and Australian, Iceland, East Indian, Cape of Good Hope, Barbary and Syrian, Turkey, Egyptian, Spain and Portugal, Italian, West Indian, and South American).	<i>Ovis aries</i>	Ruminantia . .	Europe, Asia, Africa, America, and Australia.	Weaving fine cloths, shawls, &c.	200 bales.
Pigs' hair.	<i>Sus scrofa</i>	Pachydermata	United States . . .	Making ropes, inferior brushes, &c.	30 tons.
Coney wool, or rabbits' hair.	<i>Lepus cuniculus</i> . .	Rodentia	Holland	Substitute for beaver in making hats.	*
Skins and Furs—					
Buffalo robes	<i>Bos Americanus</i> . . .	Ruminantia . .	Canada	For rugs, mats, &c. . .	500
Polar bear	<i>Ursus maritimus</i> . .	Carnivora. . . .	North America . .	For rugs.	*
Tiger	<i>Felis tigris</i>	Carnivora. . . .	East Indies	Ornamental.	*
Seal.	<i>Phoca vitulina</i> . . .	Carnivora. . . .	Newfoundland . .	Common caps, &c. . .	80,000; mostly in the raw state.
Deer	<i>Axis maculata</i> . . .	Ruminantia . .	East Indies	Ornamental.	2,000 to 3,000.
Racoon	<i>Procyon lotor</i>	Carnivora. . . .	Canada	As a coarse fur for clothing.	300.
Leopard	<i>Felis leopardus</i> . .	Carnivora. . . .	Africa	Ornamental.	*
Neutria, or Nutria . . .	<i>Myopotamus coypus</i> .	Rodentia	Rio de Janeiro . .	As a coarse fur for clothing.	1,500.
Otter, South America	<i>Lutra Braziliensis</i>	Carnivora. . . .	Rio and Bahia. . .	Clothing.	*
Otter, North America	<i>Lutra latinxina</i> . . .	Carnivora. . . .	North Carolina . .	Clothing.	*
Musquash	<i>Fiber vulgaris</i> . . .	Rodentia	Canada	Clothing.	700 to 800.
Beaver	<i>Castor fiber</i>	Rodentia	Canada	Clothing.	*
Opossum	<i>Didelphis Virginiana</i> .	Marsupialia . .	North America . .	Clothing.	2,000.
Squirrel, grey.	<i>Sciurus cinereus</i> . . .	Rodentia	North America . .	Ornamental fur	500 to 600.
Squirrel, Siberian	<i>Sciurus vulgaris</i> , var	Rodentia	Russia	Ornamental fur	*
Sable	<i>Mustela zibellina</i> . .	Rodentia	Russia	Ornamental fur	*
Ermine.	<i>Putorius ermineus</i> . .	Rodentia	Russia	Ornamental fur	*
Mink	<i>Mustela lutreola</i> . .	Rodentia	United States and the North of Europe.	Ornamental fur	*
Stone Marten	<i>Mustela foina</i>	Rodentia	Hamburgh.	Ornamental fur	*

NORTH TRANSEPT GALLERY.

COMMERCIAL NAME.	Scientific Name, or Designation.	Class or Order.	Whence Imported.	Uses, &c.	Imports, 1850.
<i>Skins and Furs—cont.</i>					
Baum Marten	<i>Mustela martes</i> . . .	Rodentia . . .	Hamburg	Ornamental fur . . .	*
Kolinski	<i>Mustela Sibirica</i> . .	Rodentia . . .	Russia	Ornamental fur . . .	*
Fitch	<i>Mustela putorius</i> . .	Rodentia . . .	Holstein and Hamburg.	Ornamental fur . . .	*
Chinchilla	<i>Chinchilla laniger</i> . .	Rodentia . . .	Valparaiso	Ornamental fur . . .	*
Bastard chinchilla . .	<i>Chinchilla brevicaudata</i> .	Rodentia . . .	Lima	Ornamental fur . . .	*
Ambergris	<i>Physeter macrocephalus</i> .	Cetacea . . .	Pacific Ocean . . .	Used as a perfume . .	*
Sperm oil	<i>Physeter macrocephalus</i> .	Cetacea . . .	New York	For burning	25 tuns.
Pot-head whale	<i>Gobiocephalus deductor</i> .	Cetacea . . .	Newfoundland . . .	For burning	325 tuns.
Seal oil (4 varieties) .	<i>Phoca vitulina</i> . . .	Carnivora . .	Newfoundland . . .	For burning	3,000 tuns.
Lard	The melted fat of swine.	Pachydermata	United States	8,000 kegs.
Bears' grease	<i>Ursus Americanus</i> . .	Carnivora . .	United States . . .	Almost useless, except as grease for work.	
Animal charcoal	<i>Carbo animalis</i>	Hamburg and France.	For sugar refining . . .	*
Tallow	The melted fat of oxen and sheep.	United States, Russia, East Indies, South America, and Australia.	Making candles, &c. . .	1,180 tuns.
Mares' oil, or horse grease.	The fat of the horse	Monte Video	Making soft soap, &c.	
Cat-gut	Manufactured from the intestines of sheep.	Naples	Strings of musical instruments.	*

Subsection 2nd, Aves—Birds.

Swan skin	<i>Cygnus olor</i>	Natatores . .	Hamburg	Ornamental clothing .	*
Guano	The indurated feces of sea birds.	South America and the Coast of Africa.	Manure	2,800 tuns.
Bolivian (Agamus). Bolivian (San Isidore). Bolivian. Peruvian. Patagonian. Ichaboe.					
Albumen	The white of eggs dried.	Havre	Used in calico printing	One small quantity only for experiment.

Subsection 3rd, Reptilia—Reptiles.

Tortoiseshell	<i>Testudo imbricata</i> . .	Chelonia . . .	W. Coast of Africa	Making combs, &c. . .	2½ tuns.
-------------------------	------------------------------	----------------	--------------------	-----------------------	----------

Subsection 4th, Pisces—Fishes.

Isinglass (East Indian)	The air-bag of several species of fish, principally of the genera <i>Silurus</i> , <i>Pimelodus</i> , and <i>Polynemus</i> .	}	Manilla	} For making a nutritious food, and various other economical purposes.	} 2 tons.			
Isinglass (Brazilian Tongue).							Peru	15 tons.
Isinglass (Maranham Tongue).							Maranham	5 tons.
Anchovies							<i>Clupea encrassicholus</i>		
Sardines.									
Cod oil	<i>Gadus Morrhua</i>	Newfoundland		2,500 tuns.			
Cod-liver oil	Oil expressed by heat from the liver of the cod-fish.	Newfoundland		300 tuns.			

Subsection 5th, Mollusca.

Cuttle-fish bones . . .	<i>Sepia officinalis</i> . .	Cephalopoda .	The Levant	Polishing metals, and making tooth-powder, &c.	18 cwt.
Conch shells	<i>Strombus pugillius</i> . .	Pectinibranchiata.	The Bahamas	For shell cameos . . .	120,000 shells.

COMMERCIAL NAME.	Scientific Name, or Designation.	Class or Order.	Whence Imported.	Uses, &c.	Imports, 1850.
Mother-of-Pearl shells, (3 varieties).	Haliotis	Manilla, Society Islands, and Pa- nama.	Buttons, knife-handles, and other ornamental articles.	120 tons.
Cowries (live) . . . Cowries (dead).	Cyprœa moneta .	Pectinibranch- iata.	East Indies . . .	Exported to Africa, where they are used as money.	444 tons.

Subsection 6th, *Insecta*—*Insects*.

Cochineal Mexican, Black. Mexican, Silver. Honduras, Black. Honduras, Silver. Truxillo, a fine sample, sent expressly for the Exhibition. Granilla, the garblings of cochineal. Cantharides, or Spanish flies.	Coccus cacti . . . Cantharis vesica- toria.	Hemiptera . Coleoptera .	South America . Spain, Russia, and Hamburgh.	For dyeing Pharmaceutical, for raising blisters.	27 tons.
---	---	---	--	--	----------------------------------

Subsection 7th, *Radiata*.

Sponge (Fine) Sponge (Honeycomb) . Sponge (Bahama) . . .	Spongia officinalis Spongia (?) . . . Spongia (?)	Turkey Turkey Nassau	Various purposes . . Various purposes . . Various purposes . .	13 cases. 25 cases. 75 bales and boxes.
--	---	-------------------------	--	--	--

Subsection 8th, *Articles produced by Insects*.

Lac (stick) Lac (lump). Lac (shell, 3 sorts). Lac (plate, 2 sorts). Lac-dye Silk (China) Silk (Italian). Silk (Italian wasli). Silk (knubs and husks). Silkworm-gut	Coccus lacca . . . Coccus lacca . . . Bombyx mori . . . Bombyx mori . . . (The secretion of the sericterium, drawn out and dried).	Hemiptera . Hemiptera . Lepidoptera . Legridopler .	East Indies . . . Italy	For varnishes Used for fishing-lines.	440 tons. *
Galls (white) Galls (blue).	Quercus Gallæ . . . (The galls produced on the oak by <i>Cynips</i> . The white galls are taken before the escape of the larva, the blue are those from which the insect has escaped).	Smyrna and Con- stantinople.	Dyeing, and in medi- cine.	277 tan
Bees'-wax (5 varieties) .	Cera flava (A secretion of the honey-bee, <i>Apis mellifica</i> , Hymen- optera).	Calcutta, Bombay, Africa, United States, &c.	For various pharma- ceutical and econom- ical purposes.	24 tons.

CLASS A.—ORGANIC SECTION. SECTION 2. VEGETABLE SUBSTANCES.

Subsection 1st, *Oils and Balsams*.

Essential oils of— Cassia	Cinnamomum Zey- lanicum. Var. cassia.	Lauraceæ. .	Hamburgh . . .	In perfumery and confec- tionery.	*
Cinnamon	Cinnamomum Zey- lanicum.	Lauraceæ. .	Ceylon and the East Indies.	Perfumery and confec- tionery.	84 lbs.
Lavender	Lavandula Spica .	Labiata . .	Hamburgh . . .	Perfumery	*
Cloves	Caryophyllus aro- maticus.	Myrtaceæ .	Holland	Perfumery and confec- tionery.	224 lbs.
Nutmegs	Myristica moschata	Myristicaceæ	Hamburgh . . .	Perfumery and confec- tionery.	*

NORTH TRANSEPT GALLERY.

COMMERCIAL NAME.	Scientific Name, or Designation.	Class or Order.	Whence Imported.	Uses, &c.	Imports, 1850.
Essential oils of— <i>cont.</i> Lemon-grass	Andropogon calamus-aromaticus.	Graminaceæ .	Calcutta	Adulterating otto of roses, and as a rube-facient.	50 lbs.
Juniper	Juniperus communis.	Coniferæ . .	Hamburgh	Pharmaceutical	2 cwt.
Cetronella	Citrus medica . .	Aurantiaceæ .	Italy	Perfumery	*
Orange (peel)	Citrus aurantia . .	Aurantiaceæ .	Messina	Perfumery	168 lbs.
Lemon	Citrus limonum . .	Aurantiaceæ .	Messina	Perfumery	4 cwt.
Neroli (orange flowers)	Citrus aurantium . .	Aurantiaceæ .	Messina	Perfumery	*
Bergamot	Citrus aurantium . Var. Bergamii.	Aurantiaceæ .	Messina	Perfumery	150.
Aniseed	Pimpinella anisum	Apiaceæ . . .	Germany	Pharmaceutical, &c. . .	*
Peppermint	Mentha piperita . .	Labiata . . .	New York	Pharmaceutical	1,000 lbs.
Cajaputi or kyaputi . .	Melaleuca minor . .	Myrtaceæ . .	East Indies	Pharmaceutical	*
Otto of roses	Rosa centifolia . .	Rosaceæ . . .	Turkey	Perfumery	*
Rosemary	Rosmarinus communis.	Labiata . . .	Hamburgh	Perfumery	*
Thyme	Origanum vulgare	Labiata . . .	Hamburgh	Pharmaceutical	*
Fixed oils of— Poppy-seed	Papaver somniferum.	Papaveraceæ	France	As salad oil, &c. . . .	3 tuns.
Pea-nut	Arachis hypogæa . .	Fabaceæ . . .	W. Coast of Africa	Dressing cloths, &c. . .	80 to 90 tuns.
Olive oil (8 varieties)	Olea Europæa	Oleaceæ . . .	South Europe	Dressing woollen cloths, &c.	10,038 tuns.
Rape oil (2 varieties)	Brassica napus	Crucifereæ .	Antwerp	Machinery, &c.	20 tuns.
Castor oil	Ricinus communis . .	Euphorbiaceæ	East & West Indies	Pharmaceutical	45 tuns.
Seed oil	Jatropha curcas . . .	Euphorbiaceæ	Lisbon	Burning in lamps, and dressing woollen cloths	700 tuns.
Palm oil	Elais Guineensis & Cocos butyracea.	Palmaceæ . .	W. Coast of Africa	Making soap, &c. . . .	16,252 tons.
Coker, coco, or cocoa-nut oil.	Cocos nucifera	Palmaceæ . .	Singapore and Manilla.	Making soap, stearine candles, &c.	340 tuns.
Oil of mace	Myristica moschata.	Myristicaceæ	East Indies	Pharmaceutical and confectionery.	*
Oil of bays	Laurus nobilis	Lauraceæ . .	Trieste	Veterinary medicine . .	*
Vegetable tallow . . .	Croton sebiferum . .	Euphorbiaceæ	China	Sent for experiment . .	*
Balsams— Tolu	Myrospermum toluiferum.	Fabaceæ . . .	Savanilla	Pharmaceutical	*
Peru	Myrospermum Peruiferum.	Fabaceæ . . .	Callao	Pharmaceutical	*
Copaiba	Copaifera multi-juga and other species.	Fabaceæ . . .	South America	Pharmaceutical	11 tuns.
Canada	Abies balsamea	Coniferæ . . .	Quebec, &c.	Pharmaceutical, &c. . .	*

Subsection 2nd, Fruits, Nuts, &c.

Mangoes (pickled) . . .	Mangifera indica	Anacardiaceæ	Calcutta	As a pickle	150 gallons.
Tamarinds	Tamarindus indica	Fabaceæ . . .	East and West Indies.	As a preserve, and medicinal.	20 tons.
Guava jelly	Psidium pyriferum	Myrtaceæ . .	South America and West Indies.	As a preserve, and medicinal.	2½ tons.
Limes (preserved) . . .	Citrus Lima	Aurantiaceæ	South America	Table fruit	15 cwt.
Olives (French and Spanish.)	Olea Europæa	Oleaceæ . . .	Spain, France, &c.	Table fruit	420 gallons.
Cranberries	Oxycoccus macrocarpus.	Vacciniaceæ .	North America	Culinary fruit	370 gallons.
Capers	Capparis spinosa (The flower buds pickled).	Capparidaceæ	France	Culinary purposes	3½ tons.
Currants or Corinths (6 varieties.)	Vitis vinifera	Vitaceæ . . .	The Greek Islands	Culinary fruit	5,450 tons.
Raisins (6 varieties) . .	Vitis vinifera	Vitaceæ . . .	South Europe	Culinary and table fruit.	2,795 tons.
Prunes	Prunus domestica (var. P. Juliana).	Drupaceæ . .	France	Table fruit	193 tons.
Pomegranates	Punica granata	Myrtaceæ . .	Lisbon, &c.	Table fruit	*
Dates, Tafilat and white Figs (3 varieties) . . .	Phœnix dactylifera . .	Palmaceæ . .	Barbary and Egypt	Table fruit	4 tons.
	Ficus carica	Moraceæ . . .	Turkey, Greece, and Malaga.	Table fruit	358 tons.
Fig cake	Compressed figs and almonds.	Moraceæ . . .	Alicant	Table fruit	2½ tons.
Ground nuts	Arachis hypogæa . .	Fabaceæ . . .	W. Coast of Africa	For eating, but chiefly for expressing oil.	400 quarters.
Pistachio nuts	Pistacia vera	Anacardiaceæ	Turkey and Greece	Edible fruit	*
Almonds (4 varieties) . .	Amygdalus communis.	Drupaceæ . .	Barbary, Spain, Sicily, and Smyrna.	Table fruit	57 tons.

NORTH TRANSEPT GALLERY.

COMMERCIAL NAME.	Scientific Name, or Designation.	Class or Order.	Whence Imported.	Uses, &c.	Imports, 1850.
Small nuts, or hazel-nuts (5 varieties).	Corylus avellana .	Corylaceæ (or Amentaceæ)	Spain, Turkey, and Sicily.	Table fruit	44,100 bushels.
Hickory nuts	Carya alba	Juglandaceæ .	North America .	Table fruit	20 bushels.
Peccan, or Pekan nuts .	Carya olivæformis .	Juglandaceæ .	North America .	Table fruit	*
Walnuts	Juglans regia	Juglandaceæ .	France and Italy .	Table fruit	2,000 bushels.
Chestnuts	Castanea vesca	Corylaceæ .	Spain	Table fruit	600 bushels.
American chestnuts .	Castanea Ameri- cana.	Corylaceæ .	North America .	Table fruit	150 bushels.
Cashew nuts	Anacardium occi- dentale.	Anacardiaceæ	East and West In- dies.	Table fruit	*
Sapucaya, or Sapucaia nuts.	Lecythis ollaria .	Lecythidaceæ	Para	Table fruit	100 bushels.
Para, Castana, or Brazil nut.	Bertholettia excelsa	Lecythidaceæ	Para and Ceara .	Table fruit	26,500 bushels.
Surahwa, or Suwarrow nut.	Caryocar butyro- sum.	Rhizobolaceæ	South America .	Table fruit	*
Coker, coco, or cocoa nut.	Cocos nucifera .	Palmaceæ .	West Indies and South America.	Table fruit	300,000 nuts.
Vegetable-ivory nuts .	Phytolapha ma- crocarpa.	Palmaceæ .	Lima and Callao .	Making small articles, to imitate ivory.	27,000 nuts.
Coquilla nuts	Attalea funifera .	Palmaceæ .	Para	Parasol handles and other small articles.	6,625 nuts.
Betel nuts	Areca catechu .	Palmaceæ .	Calcutta	Carbonized and pow- dered, it is used as a dentifrice.	5 cwt.
Tonquin bean	Dipterix odorata .	Fabaceæ . . .	Maranham . . .	Perfuming snuff, &c. .	*

Subsection 3rd, *Materia Medica, or Medicinal Products.*

Sarsaparilla (3 varieties)	Smilax officinalis .	Smilacæ .	Tampico, Lima, and Jamaica.	5½ tons.
Quassia, or bitter wood	Picræna excelsa .	Simarubaceæ	Jamaica	150 tons.
Iceland moss	Cetraria Islandica	Lichenes . . .	Hamburgh	*
Cassia fistula	Cathartocarpus fis- tula.	Fabaceæ . . .	Calcutta	5 chests.
American spikenard .	Aralia racemosa .	Araliaceæ .	} United States {	} Imported by certain herb doctors in rather large quantities.	
White oak	Quercus alba	Corylaceæ . . .			
Black-cherry bark . . .	Prunus Virginica .	Drupaceæ . . .			
Maiden hair	Adiantum pedatum	Filices			
Lobelia	Lobelia inflata .	Lobeliaceæ . . .			
Milkweed	Asclepias Syriaca	Asclepiadaceæ			
Solomon's seal	Convallaria multi- flora.	Liliaceæ			
Algaroba, or locust-pods	Ceratonia Siligna .	Fabaceæ	South of Europe .	For the mucilage, but principally for feed- ing horses.	*
Matico	Artanthe elongata	Piperaceæ . . .	Brazil	5 cwt.
Buchu leaves	Barosma crenata, and other species.	Rutaceæ	Cape of Good Hope	7 bales.
Chiretta, or chirayta	Agathotes chirayta	Gentianaceæ .	Calcutta	5 cwt.
Chamomile flowers . . .	Anthemis nobilis .	Asteraceæ . . .	Hamburgh	10 cwt.
Senna leaves (East In- dian).	Cassia elongata .	Fabaceæ	Bombay	1½ ton.
Senna leaves (Alexan- drian).	Cassia acutifolia, and other species.	Fabaceæ	Alexandria	15 cwt.
Dill seed	Anethum graveo- lens.	Apiaceæ	Leghorn	*
Quince seeds	Cydonia vulgaris .	Pomaceæ	Italy	110 lbs.
Cocculus Indicus	Anamirta cocculus.	Menispermaceæ.	Malabar	*
Indian hemp	Cannabis sativa .	Cannabinaceæ	Calcutta	*
Chicory-root	Cicorium intybus .	Asteraceæ . . .	Hamburgh	Medicinal, but chiefly used for the adulter- ation of coffee.	5 tons.
Rose leaves	Rosa gallica	Rosaceæ	Hamburgh	3 cwt.
Pomegranate bark	Punica granatum.	Myrtaceæ	Barbary	*
Worm seed	Artemisia maritima	Asteraceæ . . .	The Levant	*
Juniper berries	Juniperus commu- nis.	Coniferæ	Hamburgh	200 bags.
Cardamoms (2 varieties)	Elettaria cardamo- mum.	Zingiberaceæ	Madras and Java	15 cwt.
Guinea grains, or grains of paradise.	Amomum grana pa- radisi.	Zingiberaceæ	Guinea Coast	1 ton.
Caraway seed (2 varie- ties).	Carum carui	Apiaceæ	Holland and Ger- many.	37 tons.
Cumin seed	Cuminum cyminum	Apiaceæ	Malta and Sicily	6 cwt.
Fenugreek seed	Trigonella fœnum græcum.	Fabaceæ	Leghorn and Ger- many.	Veterinary medicines	15 cwt.

COMMERCIAL NAME.	Scientific Name, or Designation.	Class or Order.	Whence Imported.	Uses, &c.	Imports, 1850.
Cubebs	Piper cubeba	Piperaceæ	Brazil	Medicinal	8 tons.
Aniseed (2 varieties)	Pimpinella anisum	Apiaceæ	Germany, Holland, and Alicant.	1½ tons.
Peruvian bark	Several species of Cinchona.	Rubiaceæ	South America	35 tons.
Crown, or Loxa.					
Ash, or Jaen.					
Grey, or silver.					
Red.					
Royal yellow.					
Pink root	Spigelia Marilandica.	Spigeliaceæ	United States	*
Pareira brava	Cissampelos pareira	Menispermaceæ	South America	*
Aristolochia root	Aristolochia rotunda.	Aristolochiaceæ	South of Europe	*
Galangal root	Alpinia galanga	Zingiberaceæ	Singapore	8 tons.
Cascarilla bark	Canella alba	Canellaceæ (?)	Nassau	1½ tons.
Snake root	Polygala senega	Polygalææ	New Orleans	15 cwt.
Squill root	Scilla Maritima	Liliaceæ	Malta	*
Contrayerva root	Dorstenia contrayerva.	Moraceæ	St. Vincent	*
Black hellebore	Helleborus niger	Ranunculaceæ	Hamburgh	*
Angelica root	Archangelica officinalis.	Apiaceæ	Hamburgh	2 bales.
China root	Smilax China	Smilacææ	China	*
Rhatany root	Krameria triandra	Polygalææ	Peru	*
Iris, or orris root	Iris florentina	Iridaceæ	Leghorn & Trieste	Perfumery, &c.	3 tons.
Calumba root	Cocculus palmatus	Menispermaceæ	Mozambique	*
He, or male jalap	Ipomæa orizabensis	Convolvulaceæ	Mexico	As a substitute for true Jalap.	2 tons.
Jalap (true)	Exogonium purga	Convolvulaceæ	Vera Cruz	15 tons.
Rhubarb (2 varieties)	Root of one or more plants of the genus rheum.	Polygonaceæ	Turkey and the East Indies.	25 tons.
Gentian root	Gentiana lutea	Gentianaceæ	Hamburgh and Marseilles.	6 tons.
Sassafras root	Sassafras officinalis	Lauraceæ	North America	30 cwt.
Sassafras bark	Sassafras officinalis	Lauraceæ	North America	*
Liquorice root	Glycyrrhiza glabra	Fabaceæ	Naples and Germany.	5 tons.
Ipecacuanha root	Cephælis ipecacuanha.	Rubiaceæ	Rio Janeiro	20 bales.
Colocynth apples	Citrullus colocynthis.	Cucurbitaceæ	Spain, Smyrna, and Mogadore.	20 chests.

Subsection 4th, Vegetable Juices and Extracts, &c.

Liquorice juice and extract.	Glycyrrhiza glabra	Fabaceæ	Italy and Sicily	Medicinal and other purposes.	40 tons.
Indian rubber, or caoutchouc (5 varieties).	Siphonia elastica	Moraceæ	Maranham	Very various	500 tons.
Gutta percha	Isonandra gutta	Sapotaceæ	Singapore	Very various	280 tons.
Burgundy pitch	Abies excelsa	Coniferae	Hamburgh	Pharmaceutical	10 cwt.
Frankincense	Abietis resina	Coniferae	Hamburgh	Pharmaceutical and for incense.	*
Rosin (2 varieties)	United States	Various	500 tons.
Gums and Gum Resins, &c.—					
Copal (African)	Hymenæa (Sp.?)	Fabaceæ	Sierra Leone	Varnish	17 tons.
Copal (Australian)	Dammara Australis	Coniferae	Australia and New Zealand.	Varnish	14 tons.
Copal (South America)	Hymenæa (Sp.?)	Fabaceæ	Brazil	Varnish	2 tons.
Anime	Hymenæa Courbaril.	Fabaceæ	Bombay	Varnish	17 tons.
Aloes (Hepatic)	Alôe socotrina (various).	Liliaceæ	Bombay	Medicinal	2 tons.
Aloes (Cape)	Alôe spicata	Liliaceæ	Cape of Good Hope	Medicinal	6 tons.
Aloes (Cayenne)	Alôe indica (?)	Liliaceæ	Curaçoa	Medicinal	*
Aloes (Indian)	Alôe indica	Liliaceæ	Calcutta	Medicinal	*
Aloes (Socotrine)	Alôe socotrina	Liliaceæ	Bombay	Medicinal	3 tons.
Aloes (Barbadoes)	Alôe vulgaris	Liliaceæ	West Indies	Medicinal	*
Extract of logwood	Hæmatoxylon campechianum.	Fabaceæ	South America	Medicinal	*
Extract of rhatany root	Krameria triandra	Polygalææ	Lima and Callao	Medicinal	*
Gum Kino	Pterocarpus marsupium (?).	Fabaceæ	East Indies	Medicinal	*

COMMERCIAL NAME.	Scientific Name, or Designation.	Class or Order.	Whence Imported.	Uses, &c.	Imports, 1850.
Gums and Gum Resins, &c.— <i>cont.</i>					
Manna	Ornus Europæa .	Oleaceæ . .	Sicily	Medicinal	21 cwt.
Opium	Papaver somniferum.	Papaveraceæ.	Smyrna	Medicinal	15 chests.
Gamboge (2 varieties)	Hebradendron cambogioides.	..	Africa	Medicinal, and for water colour painting.	*
Vegetable Wax . . .	Corypha cerifera .	Palmaceæ . .	Para and Ceara . .	Making candles, &c. .	*
Dragon's blood (2 varieties).	Calamus draco (?)	Palmaceæ . .	Calcutta	Staining horn, and producing an imitation of tortoiseshell.	1 ton.
Guaiacum	Guaiacum officinale	Zygophylleæ .	West Indies	Medicinal	7 tons.
Red gum	Xanthorrhœa arborea.	Liliaceæ . .	Swan River	Varnishes	*
Yellow Gum	Xanthorrhœa hastilis.	Liliaceæ . .	Swan River	Varnishes	*
Gum Ammoniacum . .	Dorema ammoniacum.	Apiaceæ . .	Bombay	Medicinal	17 tons.
Gum Assafetida (2 varieties).	Ferula assafetida	Apiaceæ . .	Bombay	Medicinal	2 tons.
Scammony (2 varieties)	Convolvulus scammonia	Convolvulacæ	Smyrna	Medicinal	12 cwt.
Gum Benzoin (5 varieties).	Styrax Benzoin .	Styraceæ . .	East Indies	Medicinal, and for varnishes, &c.	4 tons.
Gum olibanum . . .	Boswellia thurifera	Amyridaceæ	East Indies	Medicinal, and for varnishes, &c.	5 tons.
Gum myrrh (2 varieties).	Balsamodendron myrrha.	Amyridaceæ	East Indies and Turkey.	Medicinal, and for varnishes, &c.	2 tons.
Gum juniper	Callitris quadrivalvis.	Coniferæ . .	Mogadore	Varnishes	*
Gum mastic	Pistacia lentiscus .	Anacardiaceæ	Constantinople . .	Varnishes	12 cwt.
Gums Arabic, senegal, gedda, Barbary, &c.	Various species of Acacia.	Fabaceæ . .	East Indies and Africa.	Various purposes . .	32 tons.
Turpentine (4 varieties.)	Pinus palustris and Pinus tæda.	Coniferæ . .	North America . .	Various purposes . .	470 tons.

Subsection 5th, Dyeing Materials.

Nicaragua wood (2 varieties).	Cæsalpinia echinata.	Fabaceæ . .	Rio de la Hache & Lima.	570 tons.
Green Ebony	Jacaranda ovalifolia.	Bignoniaceæ.	Brazil	30 tons.
Camwood	Baphia nitida . .	Fabaceæ . .	Sierra Leone and Trade Town.	110 tons.
Sapan wood	Cæsalpinia Sappan	Fabaceæ . .	Calcutta	120 tons.
Brazillets wood . . .	Cæsalpinia bahamensis.	Fabaceæ . .	Nassau (New Providence).	76 tons.
Zante, or Young Fustic	Rhus cotinus . . .	Anacardiaceæ	Zante, Patras, and Ithaca.	356 tons.
Barwood	Baphia nitida . .	Fabaceæ . .	The West Coast of Africa, Old Calabar.	350 tons.
Logwood (5 varieties) .	Hæmatoxylon campechianum.	Fabaceæ . .	St. Domingo, Tobasco, Honduras, Jamaica, Campeachy.	1,700 tons.
Red Sande, or Red Sandal wood.	Pterocarpus Santalinus.	Fabaceæ . .	Calcutta	246 tons.
St. Domingo Fustic . .	Maclura tinctoria	Moraceæ . .	St. Domingo	120 tons.
Lananilla Fustic . . .	Maclura tinctoria	Moraceæ . .	Lananilla	460 tons.
Cuba Fustic	Maclura tinctoria	Moraceæ . .	Island of Cuba	220 tons.
Rio Brazil wood . . .	Cæsalpinia brasiliensis.	Fabaceæ . .	Rio de Janiero	320 tons.
Annotto, or Annatto, and Annatto seeds.	Bixa orellana . . .	Flacourtiaceæ	South America	8 tons.
Munjeet, or Indian madder, or Bengal madder	Rubia cordifolia . .	Rubiaceæ . .	Bombay Calcutta, &c.	Red dye	525 tons.
Safflower (Bengal) . .	Carthamus tinctorius.	Compositæ . .	Calcutta (in bales)	Dyeing pink, making rouge, &c.	4 tons.
Safflower (Bombay) . .	Carthamus tinctorius.	Compositæ . .	Bombay (in bales)	Dyeing, &c.	12 tons.
Yellow berries (Persian)	Rhamnus infectorius.	Rhamnaceæ . .	The Levant	Dyeing (particularly leather).	115 tons.
Yellow berries (Turkey)	Rhamnus infectorius.	Rhamnaceæ . .	Smyrna and Constantinople.	Dyeing (particularly Morocco leather).	115 tons.
Lima orchella, or Archella weed.	Roccella tinctoria	Lichenes . .	Lima and Valparaiso.	In manufacturing the dye called orchill.	2 tons.
Orchella weed	Angola	Cape de Verde Islands.	8 tons.

COMMERCIAL NAME.	Scientific Name, or Designation.	Class or Order.	Whence Imported.	Uses, &c.	Imports, 1850.
Madder roots (3 varieties).	Rubia tinctorum .	Rubiaceæ .	Turkey, the Levant, and Bombay.	Dyeing	2,985 tons.
Turmeric	Curcuma Longa .	Zingiberaceæ	Bombay, Calcutta, and Madras.	Principally for dyeing; it is used in curries.	414 tons.
Quercitron bark (2 varieties).	Quercus tinctoria	Corylaceæ .	Philadelphia and Baltimore.	For dyeing	514 tons.
Alkanet root	Radix anchusæ .	Boraginaceæ.	Hamburg and South of France.	Gives a red colour to oils, fats, and wax.	5 cwt.
Caracas indigo	Brazil
Oude indigo	Calcutta	7 tons.
Bengal indigo	Bombay	2½ tons.
Sumach or shumach .	Rhus Coriaria . .	Anacardiaceæ	Sicily and the South of Europe.	For dyeing	350 tons.
French sumach	Marseilles	93 tons 15 cwt.
Fine ground Sicilian sumach.	Palermo	93 tons 15 cwt.
Tyrol ground sumach	Trieste	93 tons 15 cwt.
Garancine	A dye formed by semi-carbonizing finely powdered madder with sulphuric acid at a temperature of 212°.	30 tons.
Dutch ground madder	Rotterdam	270 tons.
French ground madder	Marseilles	30 tons.
Spanish ground madder	Seville	10 tons.

Subsection 6th, Tanning Materials.

Oak or tanners' bark (2 varieties).	Quercus (various species).	Corylaceæ .	Holland and Belgium.	For tanning leather .	514 tons.
Divi divi (3 varieties) .	Cæsalpina coriaria	Fabaceæ .	Rio de la Hache, Savanilla, and Maracaibo.
Cork tree bark	Quercus suber .	Corylaceæ .	Rabat	160 tons.
Algarobilla	Prosopis pallida .	Fabaceæ . .	Valparaiso	A substitute for divi divi in tanning.	400 tons.
Valonia (3 varieties) .	Quercus ægilops .	Corylaceæ .	Smyrna	A tanning material.
Myrobalans (2 qualities)	Terminalia chebula	Combretaceæ	Calcutta and Bombay.	For dyeing yellow and black colours.	851 tons.

Subsection 7th, Spices.

Cinnamon	Cinnamomum zeylanicum.	Lauraceæ .	Ceylon and Madras	4 tons.
Cassia	Cinnamomum zeylanicum, var. Cassia.	Lauraceæ .	China, &c.	21 tons.
Clove bark	Dicypellium caryophyllatum.	Lauraceæ .	Brazil	*
Ginger (3 varieties) .	Zingiber officinale	Zingiberaceæ	East and West Indies, and Sierra Leone.	24 tons.
Mace	Myristica moschata	Myristicaceæ	East Indies	*
Nutmegs (Cape and Penang).	Myristica moschata	Myristicaceæ	East India Island, Cape of Good Hope.	10 cwt.
Wild or shell nutmegs .	Myristica Madagascariensis.	Myristicaceæ	Madagascar.
Cloves	Caryophyllus aromaticus.	Myrtaceæ .	Phillipine Island	13 boxes.
Pepper (black and white, 4 varieties).	Piper nigrum . . .	Piperaceæ .	East Indies	379 tons.
Pimento or Jamaica pepper.	Eugenia pimenta .	Myrtaceæ .	West Indies.

Subsection 8th, Oil Seeds.

Niger seed	Verbesina sativa .	Asteraceæ .	East Indies	Expressing oil	370 qrs.
Rape seed	Brassica napus .	Crucifereæ .	East Indies	Expressing oil	700 qrs.
Gingelli or sesamum seed.	Sesamum orientale	Pedaliaceæ .	East Indies	Expressing oil	3,700 bags.
Linseed (3 varieties) .	Linum usitatissimum.	Linaceæ . .	East Indies, Egypt, and Russia.	Expressing oil	2,600 qrs.

COMMERCIAL NAME.	Scientific Name, or Designation.	Class or Order.	Whence Imported.	Uses, &c.	Imports, 1850.
Poppy seed (2 varieties)	Papaver somniferum.	Papaveraceæ.	East Indies, Holland, and Germany.	Expressing oil and feeding small birds.	*
Marking nuts . . .	Semecarpus anacardium.	Anacardiaceæ	Calcutta . . .	Expressing oil, &c. . .	5 tons.
Castor oil seeds . . .	Ricinus communis	Euphorbiaceæ	East Indies . . .	Medicinal oil	*
Cotton seed	Gossypium herbaceum.	Malvaceæ . .	New Orleans . . .	Expressing oil	*
Croton nuts, physic nuts	Jatropha curcas . .	Euphorbiaceæ	Cape de Verd . . .	Expressing oil	*
Hemp seed (3 varieties)	Cannabis sativa . .	Cannabinaceæ	Sicily, Holland, and Russia.	Expressing oil and feeding small birds.	130 qrs.
Mustard seed (brown) .	Sinapis nigra . . .	Cruciferae .	Holland and the East Indies.	Expressing oil and grinding into flour mustard.	1,700 qrs.
Mustard seed (white) .	Sinapis alba . . .	Cruciferae .	Holland and the East Indies.	Expressing oil and grinding into flour mustard.	1,700 qrs.

Subsection 9th, Agricultural Seeds.

Lucerne	Medicago sativa .	Fabaceæ . . .	Hamburgh.	5 tons.
Timothy grass	Phleum pratense .	Graminaceæ .	United States	2½ tons.
Parsnip	Pastinaca sativa .	Apiaceæ . . .	Germany	5 tons.
Italian rye grass . . .	Lolium Italicum .	Graminaceæ .	Leghorn	4 qrs.
Canary seed	Phleum Canariense	Cannabinaceæ	Germany	Feeding birds	*
Clover (American) . .	Trifolium Pennsylvanicum.	Fabaceæ . . .	United States	320 tons.
Clover (Dutch)	Trifolium repens .	Fabaceæ . . .	Rotterdam	3 tons.
Millet seed	Panicum miliaceum.				

Subsection 10th, Dietetic Articles.

Sugar (30 varieties . .	Saccharum officinarum.	Graminaceæ .	East and West Indies, South America, &c.	108,952 tons.
Tea (18 varieties) . .	Thea viridis and Thea bohea.	Ternströmiaceæ.	China	9,117,726 lbs.
Rice	Oryza sativa . . .	Graminaceæ .	United States and the East Indies.	4,156 tons.
Coffee	Coffea arabica . .	Rubiaceæ . . .	East and West Indies and South America.	3,672 tons.
Wheat and wheat flour.	Triticum æstivum and hibernicum.	Graminaceæ .	Europe, North and South America, &c.	714,406 qrs.
Barley	Hordeum (2 or 3 species.)	Graminaceæ .	Europe	38,613 qrs.
Oats	Avena sativa . . .	Graminaceæ .	Europe	25,595 qrs.
Indian corn and meal .	Zea mays	Graminaceæ .	Europe and North America.	497,186 qrs.
Peas	Pisum sativum . . .	Fabaceæ	Europe	19,022 qrs.
Beans (Egyptian) . . .	Faba vulgaris . . .	Fabaceæ	Egypt	Food for horses. . . .	116,646 qrs.
Beans (American) . . .	Phaseolus vulgaris	Fabaceæ	America	400 qrs.
Buckwheat	Fagopyrum esculentum.	Polygonaceæ .	Holland and Germany.	800 qrs.
Lentils	Ervum lens	Fabaceæ	Egypt, &c.	430 qrs.
Durra	Andropogon sorghum.	Graminaceæ .	Turkey	Feeding cattle, &c. . .	130 qrs.

Subsection 11th, Vegetable Fibres, &c.

Cotton wool (40 varieties arranged; showing the country, variety, value per lb., and the staple).	Gossypium herbaceum.	Malvaceæ . .	North and South America, Egypt, East Indies, West Indies, and Port Natal.	For weaving into cloths, &c.	322,605 tons.
Hemp	Cannabis sativa . .	Cannabinaceæ	North of Europe, East Indies, and America.	Weaving and making cordage.	10,300 bales, say 5,000 tons.
Manilla hemp	Musa textilis . . .	Palmaceæ . . .	East Indies	Cordage	192 tons.
Jute	Corchorus capsularis.	Tiliaceæ	East Indies	Cordage of inferior quality, matting, and even for adulterating silk.	12,216 tons.

NORTH TRANSEPT GALLERY.

COMMERCIAL NAME.	Scientific Name, or Designation.	Class or Order.	Whence Imported.	Uses, &c.	Imports, 1850.
Brazilian jute . . .	(?)	..	Para	Only a small quantity for experiment.	
Bengal hemp . . .	Crotalaria juncea .	Fabaceæ . .	East Indies . .	Coarse bagging . . .	81 tons.
Flax (Dutch, and Egyptian).	Linum usitatissimum.	Linaceæ . .	Holland, Egypt, &c.	Weaving linen cloth .	423 tons.
Tow	The refuse of flax	..	Holland and Italy	Surgical purposes, stuffing, &c.	*
China grass . . .	Bœhmeria nivea .	Urticacæ . .	Canton, &c. . . .	Weaving fine linen .	320 bales.
Piassava or Piacaba .	Attalea funifera .	Palmaceæ . .	Brazil	Making brushes, &c. .	300 tons.
Coir (rope and yarn) .	Cocos nucifera .	Palmaceæ . .	East Indies	Cordage	1,470 tons.
Vegetable silk . . .	Chorisia speciosa .	Malvaceæ . .	Brazil	Stuffing cushions, &c. .	*
Palm leaves and leaf fibres of the Carnanba palm.	Corypha cerifera .	Palmaceæ . .	Brazil	Imported for experiment	
Canes—					
Rattan	Calamus verus and others.	Palmaceæ . .	East Indies	Chair bottoms, &c. .	5,600 bundles.
Partridge	Calamus niger (?)	Palmaceæ . .	East Indies and China.	Walking sticks, &c. .	1,300 canes.
Malacca	Calamus zalacca .	Palmaceæ . .	East Indies and China.	Walking sticks, &c. .	300 canes.
Bamboo	Bambusa arundinacea.	Graminacæ .	East Indies, &c. .	Principally for ships dunnage.	

Subsection 12th, Timber and Hard Woods.

St. John yellow pine .	Pinus variabilis .	Coniferæ . .	Brit. N. America.		
Quebec yellow pine .	Pinus variabilis .	Coniferæ . .	Brit. N. America.		
American spruce pine .	Abies rubra . . .	Coniferæ . .	Brit. N. America.		
Quebec red pine . . .	Pinus resinosa . .	Coniferæ . .	Brit. N. America.		
Savannah pitch pine .	Pinus palustris .	Coniferæ . .	South America.		
North American black birch.	Betula nigra . . .	Betulaceæ .	North America.		
Quebec rock elm . . .	Ulmus Americana .	Ulmaceæ . .	North America.		
New Orleans oak . . .	Quercus virens . .	Corylaceæ .	New Orleans.		
Quebec oak	Quercus alba . . .	Corylaceæ .	Brit. N. America.		
Riga oak	Quercus robur . .	Corylaceæ .	The Baltic Ports.		
African oak, or teak wood.	Euphorbiaceæ	W. Coast of Africa		
Sabiceu (St. Domingo)	(?)	St. Domingo.		
Sabiceu (Cuba)	(?)	Cuba.		
Rosewood (Honduras)	Two or three undetermined species of Triptolomea.	} Fabaceæ . .	South America.		
Rosewood (Rio) . . .					
Rosewood (Bahia) . .					
Cedar (pencil)	Juniperus Virginiana.	Coniferæ . .	North America.		
Cedar (Honduras) . .	Cedrela odorata .	Cedrelaceæ .	South America.		
Satinwood (St. Domingo)	(?)	(?)	St. Domingo.		
Black wood, or East Indian teak.	(?)	(?)	Calcutta, &c.		
Gateado, or zebra . . .	Omphalobium Lambertii.	Connaracæ .	New Zealand and Australia.		
Hemlock fir	Coniferæ . .			
Hackmatack	Coniferæ . .			
Locust	Hymenæa courbaril	Fabaceæ . .			
Mahogany (Honduras)	Swietenia mahagoni	Cedrelaceæ .	South America and West Indies.		
Mahogany (St. Domingo)	Swietenia mahagoni	Cedrelaceæ .	South America and West Indies.		
Mahogany (Cuba) . . .	Swietenia mahagoni	Cedrelaceæ .	South America and West Indies.		
Honduras Brazilletto .	(?)	(?)	Honduras.		
(Said to be common Brazilletto deprived of its colouring matter. This is hardly probable).					
Tulip wood	(?)	(?)	East Indies.		
Lance wood	Duquetia quitarensis.	Anonaceæ . .	Guiana.		
Purple wood, or purple-heart.	Copaifera pubiflora	Fabaceæ . .	Guiana.		
American ash	Fraxinus Americana.	Oleaceæ . .	North America.		
Lignum vitæ	Guaiacum (Sp.?) .				
Russian black walnut .	Juglans (Sp.?) . .	Juglandaceæ .	Riga.		
Australian mahogany .	(?)	Eucalyptus (?)			
African tulip wood . . .	(?)	Africa.		
African yellow wood . .	(?)	Africa.		

NORTH TRANSEPT GALLERY.

COMMERCIAL NAME.	Scientific Name, or Designation.	Class or Order.	Whence Imported.	Uses, &c.	Imports, 1850.
Bahama satin wood . . .	(?)		Nassau.		
Hickory wood . . .	Carya alba . . .	Juglandaceæ.	Brit. N. America.		
Cabbage wood . . .	Eriodendron anfractuosum.	Sterculiaceæ.	Jamaica.		
Coromandel wood . . .	(?)	. . .	Coromandel.		
Tortoise wood . . .	(?)	. . .	Africa.		
Brazilian beef wood . . .	(?)	. . .	Para.		
Horse-flesh, or Bahama mahogany.	(?)	. . .	Nassau.		
Vinatica	Persea indica . . .	Lauraceæ .	Madeira.		
Cocus, or kokra wood . . .	Lepidostachys Roxburghii.	Scepaceæ .	Cuba.		
Brazilian satin wood, or Pao de Amarillo.	(?)	(?)	Para.		
Violet wood	(?)	. . .	Para.		
King wood	(?)	. . .	Para.		
Carnauba wood	Corypha cerifera .	Palmaceæ .	Para.		
Botany Bay oak	Casuarina (?) . . .	Cassuarinaceæ	New Holland.		
Angica wood	(?)	. . .	Ceara and Para.		
Blue gum wood	Eucalyptus Globulus.	Myrtaceæ .	New Holland.		
Bird's-eye maple	Acer saccharinum .	Acerineæ .	North America.		
Satin wood waved	Chloroxylon Swietenia.	Cedrelaceæ .	West Indies.		
Brazilian fancy wood	(?)	. . .	Para.		
Amboyna wood (4 varieties.)	(?)	. . .	East Indies.		
Green heart	Nectandra Rodiæi	Lauraceæ .	Demerara.		
Red wood	(?)	. . .	Para.		
Orange wood	Citrus aurantium .	Aurantiacææ.	Sicily.		
Palmyra wood (3 varieties.)	Various species of palm.	Palmaceæ .	East Indies.		
Porcupine wood	A species of palm	Palmaceæ .	East Indies.		
Russian birch	Betula Daurica . . .	Betulaceæ .	Riga.		
Ebony (black)	Diospyrus ebenus . .	Ebenaceæ .	East Indies.		
Ebony (variegated).	Diospyrus ebenus . .	Ebenaceæ .	East Indies.		
Snake or letter	Piratinera guianensis.	Artocarpaceæ	Guiana.		
Olive wood	Olea Europea	Oleaceæ . . .	Sicily.		
American walnut	Juglans nigra	Juglandaceæ.	North America.		
Texican oak	Quercus Mexicana?	Corylaceæ .	Texas.		

IMPORTS OF TIMBER AND HARD WOOD IN 1850.

American pine timber	Cubic feet	5,652,213	Birch	Cubic feet	343,709
Red pine	Cubic feet	302,017	Quebec oak	Cubic feet	354,684
Quebec deals	Standard of 120	4,517	Quebec elm	Cubic feet	160,188
Pine and spruce planks (2 feet)	Cubic feet	24,987,918	Quebec ash	Cubic feet	8,324
Boards	Cubic feet	501,874	Pitch pine	Cubic feet	30,404

Baltic Timber.

Timber	Cubic feet	399,255	Billet (wainscot).	Billets	1,103
Deals	Standard of 120	1,246	Staves	Standard of 1,200	50
Battens	Standard of 120	266	Lathwood	Fathoms	702
Poles and spars	Cargoes	2			

American Worked Timber.

Masts and spars	Pieces	171	United States staves	Standard of 1,20	1,219
Ash oars and handspikes	Pieces	14,309	Lathwood	Fathoms	950
Quebec staves	Standard of 1,200	225	Railway sleepers	Pieces	22,246
New Brunswick, &c., ash hogsheads staves	Standard of 1,200	101			

Hard and Fancy Woods.

Mahogany	Tons	6,812	Teak	Feet	131,976
Cedar	Feet	149,530	Greenheart and Mora	Feet	74,838
Bird's-eye maple	Planks	417	Sabicue	Logs	7
Zebra wood	Planks	178	Lignum vitæ	Tons	1,770
Satin wood	Logs	210	Ebony	Tons	350
Rosewood	Planks	7,807	Cocus wood	Tons	96
Lancewood	Spars	10,653			

NORTH TRANSEPT GALLERY.

COMMERCIAL NAME.	Scientific Name, or Designation.	Class or Order.	Whence Imported.	Uses, &c.	Imports, 1850.
<i>Subsection 13th, Miscellaneous.</i>					
Hops	<i>Humulus lupulus</i>	Cannabinaeæ	North America .	For brewing beer . .	37 tons.
Rushes	<i>Scirpus lacustris</i>	Graminæeæ .	Holland	Used by coopers.	

Subsection 14th, Tobacco.

Dutch	<i>Nicotiana (Sp.?)</i>	Solanaceæ .	Java	} Smoking	} Total quantity imported in 1850, 25·316 tons, 131tons.
Maryland	<i>Nicotiana tabacum</i>	..	New Orleans		
Kentucky (2 varieties)	New Orleans		
Virginia (2 varieties)	New Orleans		
Havannah	<i>Nicotiana repanda</i>	..	Cuba		
Cuba	Cuba		
Yara	Cuba		
La Guayra	South America		
Paraguay	South America		
Columbian	South America		
Ipala	South America		
Manilla	<i>Nicotiana rustica</i> .	..	East Indies		
German	Hamburg		
Turkish	<i>Nicotiana paniculata</i> .	..	Turkey		
Latakia	<i>Nicotiana rustica</i> .	..	Syria		
Chinese	<i>Nicotiana sinensis</i>		
Manufactured— Cigars. Roll (Varinas). Roll (Brazil). Cavendish. Negro-head.					

Subsection 15th, Feculas.

*Tapioca (Rio)	<i>Janipha manihot</i> .	Euphorbiaceæ	Rio de Janeiro	Food	700 tons.
*Tapioca (Bahia) . . .	<i>Janipha manihot</i> .	Euphorbiaceæ	Bahia	Food	120 tons.
*Cassava powder . . .	<i>Janipha manihot</i> .	Euphorbiaceæ	Brazils	Food	Small.
*Farinha	<i>Janipha manihot</i> .	Euphorbiaceæ	Brazils	Food	300 tons.
Sago (Borneo)	<i>Sagrus lævis</i> . . .	Palmaceæ .	Borneo	Food	Small.
Sago (granulated) . .	<i>Sagrus Rhumphii</i>	Palmaceæ .	Calcutta	Food	78 tons.
Sago (pearl)	<i>Sagrus Rhumphii</i>	Palmaceæ .	Calcutta	Food	425 tons.
Sago (flour)	<i>Sagrus Rhumphii</i>	Palmaceæ .	Calcutta	Food	225 tons.
Arrow root (St. Vincent)	<i>Maranta arundinaceæ</i> .	Cannaceæ .	St. Vincent, West India Islands.	Food	50 tons.
*Brazilian arrow root .	<i>Janipha manihot</i> .	Euphorbiaceæ	Brazils	Food	7 tons.
Farinha (potato) . . .	<i>Solanum tuberosum</i>	Solanaceæ .	France, Holland, and Germany.	Dressing textile fabrics	160 tons.
Dextrine	Starch acted upon by sulphuric acid and water at a temperature of 200° Fah.

* These articles are all formed from the same plant, the Rio Tapioca is the best; and Farinha or Mandioca is the lowest quality.

CLASS B.—Section 1st, Metallic.

COMMERCIAL NAME.	Scientific Name.	Whence Imported.	Uses.	Imports, 1850.
Copper	Cuprum	South America, Australia, &c.	Various	450 tons.
Nickel	Nickel	Hamburg	Making German silver &c.	20 tons.
Bismuth	Bismuth	Germany	Making type metal, solder, &c.	10 cwt.
Antimony	Antimonium	Germany	Type metal, pewter, &c.	4 tons.
Tin	Stannum	Malacca and Banca, via Calcutta.	Various	70 tons.
Lead	Plumbum	Malaga, Spain, &c.	Various	200 tons.
Iron and steel	Ferrum	Russia, Sweden, Trieste, and North Brunswick.	Various	1,100 tons.

NORTH TRANSEPT GALLERY.

COMMERCIAL NAME.	Scientific Name.	Whence Imported.	Uses.	Imports, 1850.
Zinc or spelter	Zincum.			
Antimony ore	Sulphuret of antimony	Germany	Smelting for antimony . .	70 tons.
Copper ores	Sulphuret of copper .	South America and Australia.	Smelting for copper . . .	14,030 tons.
Copper ores	Carbonate of copper (green).	South America and Australia.	Smelting for copper . . .	14,030 tons.
Copper ores	Carbonate of copper (blue).	South America and Australia.	Smelting for copper . . .	14,030 tons.
Copper ores	Muriate	South America and Australia.	Smelting for copper . . .	14,030 tons.
Copper regulus	The ore deprived of its sulphur by roasting.	South America . . .	Smelting for silver . . .	750 tons.
Copper barilla	The ore deprived of its sulphur by roasting, and powdered.	South America . . .	Smelting for silver . . .	750 tons.
Silver ores (3 varieties)	Sulphuret of silver . .	South America . . .	Smelting for silver . . .	750 tons.
Red arsenic	Arsenicum bisulphu- retum.	Holland	As a pigment, &c. . . .	3 tons.
Lead ore	Galena, sulphuret of lead	Australia and North America.	Smelting for lead	250 tons.
Oxide of manganese (2 va- rieties).	Peroxide of manganese or pyrosulite.	Germany, Spain, &c. .	Calico printing and glass manufactures.	2,300 tons.
Chromate of iron (3 varie- ties).	Chromic iron or chro- mite.	United States, Sweden, Russia, &c.		
Cobalt ore	Smaltine	Norway and Germany	Making smalts, &c. . . .	100 tons.

Section 2nd, Non-Metallic.

Marbles— Italian Bardiglio	Fancy marbles are not often imported; the total quantity of all sorts is about 600 tons per annum.			
American Bardiglio				
White statuary				
Veined statuary				
Black and gold				
Sienna				
Belgian brown				
Italian dove coloured				
St. Ann's (Belgian), and 3 other varieties.				
Phosphate of lime	Phosphurite	New Jersey	As a manure	3 tons.
Burr stone	Mill stone grit	France	For making large millstones	500 tons.
Barytes (carbonate)	Witherite	New York	Manufacture of chloride of barium.	20 tons.
Barytes (sulphated)	Hepatite	New York	Making pigments	*
Felspar	Orthose	New York and the Mediterranean.	Porcelain manufactures . .	120 tons.
Talc	Silicate of magnesia . .	Calcutta	Various	3 tons.
Plumbago or black lead (5 varieties).	Graphite	North America, Ger- many, and Ceylon.	Various	536 tons.
Amber	Succinum	Memel	Ornamental and pharma- ceutical purposes.	*
Asphalt or asphaltum	Bitumen var. asphalte	New York	Paving, &c.	70 tons.
Emery (3 varieties)	Granular corundum . .	Naxos, Smyrna, and Australia.	For polishing metals . . .	1,200 tons.
Pozzolano	Puozzolana, a volcanic product.	Leghorn, Naples, &c. .	Cement	400 tons.
Pumice stone	Spongy obsidian	Naples, Palermo, &c. .	Polishing	7 tons.
Brimstone	Sulphur	Palermo, Messina, &c.	Making gunpowder, matches, &c.	10,650 tons.
Brazilian pebbles	Rock crystal	Rio de Janeiro . . .	Spectacle and other optical instruments.	*
Aqua marine	Silicate of alumina and glucine.	Rio de Janeiro . . .	Jewellery	*
Oriental topaz	Silicate of alumina . .	Rio de Janeiro . . .	Jewellery	*
Chrysolite	Silicate of magnesia and iron.	Rio de Janeiro . . .	As a substitute for diamonds in jewelling watches.	32,924 carats.
Amethyst	Amethystine quartz . .	Rio de Janeiro . . .	As a substitute for diamonds in jewelling watches.	*
White topaz	Rio de Janeiro . . .	As a substitute for diamonds in jewelling watches.	*
Brazilian topaz	Fluo-silicate of alu- mina.	Rio de Janeiro . . .	As a substitute for diamonds in jewelling watches.	15 cwt.
Cream of tartar (5 varie- ties).	Potassæ bitartras . . .	Italy, Spain, France, &c.	Manufacture of tartaric acid, &c.	210 tons.
Argols (5 varieties)	Impure bitartrate of potash.	Italy, Spain, France, &c.	Manufacture of tartaric acid, &c.	600 tons.
Turkey umber	A silicate of alumina combined with oxides of iron and manga- nese.	Smyrna and Leghorn .	Pigment	7 tons.

NORTH TRANSEPT GALLERY.

COMMERCIAL NAME.	Scientific Name.	Whence Imported.	Uses.	Imports, 1850.
Sienna earth (2 varieties)	An argillaceous earth dried.	Leghorn, &c. . . .	Pigment	13 tons.
Verdigris	Cupri subacetate . . .	France	Pigment, &c.	5 tons.
Tincal	Impure borate of soda	Calcutta	For making borax	433 tons.
Borax	Sodæ biboras	Calcutta	Used in the manufactures of glass and pottery.	30 tons.
Boracic acid	Acidum boracicum . . .	Leghorn	Used in the manufactures of glass and pottery.	850 tons.
Hydroborate of lime . .	Heyescine	Peru	Used in the manufactures of glass and pottery.	*
Alum	Alumen	China	Chemical	*
Yellow prussiate of potash	Ferrocyanide of potassium.	Havre	Calico printing	7 cwt.
Turkey stone	Hornblende	Constantinople . . .	Making hones, &c.	*
Mineral water or seltzer water.	Germany, Holland, and Belgium	Drinking	400 gallons.

272 ALCOCK, STEPHEN BOLTON, & Co., *Dublin Blacking Works*—Manufacturers.
Sample of liquid blacking.

274 MITCHELL, Rev. WILLIAM, *Woolwich, Kent*—Inventor.

Buffer and horn of a bull, with iron frame, and stuffed buffer attached, with motto, in eleven different languages. The goeing oxen buffer has been invented to prevent the numerous accidents which arise from driving infuriated animals through the crowded streets. The buffer is stuffed with soft material, similar to the balls formerly used by printers, or boxing-gloves, to which is attached a spring, that recoils on pressure. This buffer is fastened to a strong piece of iron, having two rings to slip on to the horns, and a small screw-bolt on one side that fixes it firmly in its place.

The somniferous electric brush, for producing sleep to invalids and others.

275 WESTHEAD, J. P., and E. & Co., *Manchester*—Manufacturers.

Patent Astoria cloth, manufactured of hare's fur. Bell-ropes; curtain-holders; fringe, with hangers; Jacquard bell-rope; spangle orris lace, quite new; Jacquard cord and flat Jacquard braid.

Pattern-book of general smallwares:—Cotton work-box, furnished; furnishing gimps; India tapes; imperial, or best cotton; and thread tapes.

Carpet and bed lace; float and Queen's lace, in plain and chintz; patent cotton velvet; amber curtain holders.

277 LUCAS, GEORGE, 42 *Kennedy Street, Manchester*—Inventor and Manufacturer.

Brass and zinc "erantistate" door, window, and sign-plates, engraved by machinery. The engraved part filled with a composition of any colour, or inlaid with other colours, to resist the action of the atmosphere.

Designs for letters, plates, doors, windows, &c.

278 ESDAILE, JAMES, *Elm Place, Hulme*—Inventor and Manufacturer.

Sheets of hat-felt, made by hand, from rabbit's fur and fine Saxony lamb's wool, used by printers of calicoes, silks, woollens, &c., being inserted into the blocks and cylinders to convey the colouring matter to the cloth.

Sheets of woollen-felt, for polishing plate-glass, marble, ivory, tortoiseshell, bone, &c.

Felted gloves, or hand-hats, fire-proof, and non-conductors of heat, used by glass-blowers, iron-founders, and others. Felted rustic hats.

280 SMITH, W. & A., *Mauchline, Ayrshire, Scotland, and 61 Charlotte Street, Birmingham*—Manufacturers.

Variety of articles of Scotch fancy wood work, made chiefly of the wood of the sycamore tree: consisting of snuff-boxes, cigar-cases, card-cases, card-trays, writing-

folios, books bound in wood, candlesticks, &c., ornamented in different styles.

Snuff-boxes, in various stages of progression. The "Scotch hinge" is applied to many of these articles.

By the style called "checking," a great variety of diapered patterns are produced, particularly the imitation of the clan tartans of Scotland.

By the style called "Scoto-Russian," an imitation of engine-turned lines, inlaid with silver, is produced, and the ornament, being secured by copal-varnish, is not liable to become tarnished.

281 COCKERILL, ROBERT, *Banbury*—Manufacturer.

Liquid and paste blacking, for boots, shoes, and harness. Liquid dye for harness. Polishing paste for metals. Black and red writing ink.

282 EASTERLING, JOHN, 90 *Whitecross Street, St. Luke's*—Manufacturer.

Currie paste and powder. Essence of anchovies. Invigorating sauce. Anchovy and bloater paste.

285 WOOD, P. H., 20 *Redman's Row, and Assembly Place, Mile End*—Manufacturer.

Refining powder for coffee, and colouring for soups, gravies, &c.

286 COCKS, E., *Reading*—Manufacturer.

Specimens of Reading and other sauces.

287 DUTTON & Co., *Runcorn, Cheshire*—Manufacturers.

School slates, manufactured by machinery, framed in mahogany and bird's-eye maple. Book slates. Single slate.

289 MALLALIEU, WM., 97 *Hatton Garden*—Importer.

Models of dwellings and implements made by the Esquimaux, at the Moravian settlements on the coast of Labrador, North America.

1. A winter house. 2. A snow hut. 3. A bone sledge and dogs. 4. A wooden sledge and dogs. 5. A bone kayak, and fishing implements. 6. A skin kayak, and fishing implements. 7. A woman's boat. 8. Models of reindeer, bears, seals, dogs, and birds. 9. Bone paper knives. 10. Mats and baskets, made of grass. 11. Specimens of needlework. The bone articles are made from the teeth of the walrus.

290 LOCAL COMMITTEE, *Hull*—Producer.

Specimens of the staple imported articles of the port of Hull, accompanied with the following description and statistical information.

[Hull is reckoned the fourth city in England in point of commercial importance. Its trade is chiefly with the Baltic; in the whale fishery; and by inland communication. It is very conveniently situated for traffic with

the Continent, and its imports are chiefly of continental produce, as the adjoined tabular view will show. Flax, iron, and wool, as they are the most useful, appear also to be the principal imports.]

Alkanet Root	60 cwt.	Mazerian Root	35 cwt.
Angelen Root	50 "	Millet Seed	50 qr.
Aniseeds	60 "	Moss, Iceland	430 cwt.
Arrow Root	50 "	Mustard Seed	1,000 "
Arsenic	100 "	Myrabolams	1,600 "
Asphaltum	50 "	Nickel	50 "
Barley	292,000 qr.	Oak Bark	31,800 cwt.
Bay Berries	120 cwt.	Oats	42,000 qr.
Beans	88,000 qr.	Olive Oil	3,500 tuns
Black Lead	8,300 cwt.	Onion Seed	50 cwt
Bran	11,300 "	Oss Sepia	30 "
Brimstone	650 tuns.	Paper, Ornamental	
Bristles	2,200 cwt.	Peas	46,000 qr.
Bronze Powder	310 lb.	Pepper	3,800 cwt.
Camphor	60 cwt.	Pitch, Burgundy	120 "
Canary Seed	250 qr.	Poppy Heads	65 "
Cantharides	2,500 lb.	Poppy Seed	80 "
Carraway Seed	950 cwt.	Prussiate of Potash	560 cwt.
Chamomile Flowers	560 "	Potato Flour	25,000 "
Chicory Root	5,000 "	Rape Cake	4,500 "
Clover Seed	22,000 "	Rape Oil	780 tuns
Codilla	1,100 "	Rape Seed	25,000 qr.
Coffee	2,400 "	Rice	7,200 cwt.
Colchicum Root	30 "	Rose Leaves	1,240 lb.
Coppers, White	1,000 "	Rosin	2,000 brls.
Coriander Seed	100 "	Rye	8,500 qr.
Cork	940 "	Rye Meal	15,500 cwt.
Cumin Seed	30 "	Saltpetre	2,000 "
Feathers	200 "	Sesamum Seed	15,000 qr.
Flax	310,000 "	Shumac	14,000 cwt.
Fenugreek Seed	90 "	Silk, raw	95 "
Gambier	450 "	Slate Pencils	1,500 "
Gentian Root	210 "	Smalts	520 "
Glass Beads and Bugles	150 "	Spelter	1,100 tuns
Glue	1,150 "	Stavesare	98 cwt.
Grains Paradise	50 "	Sugar, Candy	200 "
Guano	4,300 tuns	Sugar, Loaf	1,500 "
Hair, Cows'	1,250 cwt.	Sugar, Raw	4,000 "
Hair, Horse	180 "	Tallow	51,000 "
Hellebore Root	70 "	Tares	6,500 qr.
Hemp	55,000 "	Toy Marbles	1,600 cwt.
Hempseed	450 qr.	Ultramarine	4,200 lb.
Honey	1,800 cwt.	Valerian Root	230 cwt.
Iron Bars	22,000 tuns	Valonia	3,900 "
Iron Bloom	500 "	Verdigris	46 "
Juniper Berries	250 "	Vinegar	4,200 gall.
Lead Pencils	3,200 gross	Wax, Bees'	40 cwt.
Lead, Sugar of	54 cwt.	Whalebone	20 tuns
Linen Rags, Pulp of	130 "	Whale Oil	400 tuns
Linseed	322,000 qr.	Wheat	268,000 qr.
Linseed Cake	10,250 cwt.	Wheat Flour	4,300 cwt.
Liquorice Root	100 "	Wool, Cotton	96,000 "
Madders	18,000 "	Wool, Sheep's	12,524,000 lb.
Madder Roots	500 "	Worm Seeds	20 cwt.
Maize	2,100 qr.	Worsted Yarn, for	} 25,000 lb.
Manna Kroup	70 cwt.	Embroidery	
Manganese Ore	2,000 "	Yeast, dried	3,400 cwt.
Matches	50,000 gross	Zaffers	280 "
Mazerian Bark	30 cwt.		

291 BARTLETT, ABRAHAM DEE, 16 Great College Street, Camden Town—Preserver.

A life-sized model of the dodo. This extinct bird was formerly very abundant on the island of Mauritius.

[*Didus ineptus*, Linnæus. The bird which has here been restored from the most authentic portraits extant, was formerly a native of the island of Mauritius, where it was discovered by Vasco di Gama, in 1497. The species was found there in abundance by the Dutch, between the years 1598 and 1600, soon after which it appears to have become extinct. A stuffed specimen, which formed part of Tradescant's Museum in 1600, passed, with the rest of the collection, into the hands of Dr. Ashmole, and was transferred by him to the University of Oxford, where it was destroyed in 1755, with the exception of the dried head and one foot, which are still preserved.

The foot of another specimen is in the British Museum. From the shortness of the wings, which were inadequate for the purposes of flight, most naturalists have classed the dodo with the cassowary and other struthious birds; some have supposed it to be a kind of vulture; others, a sort of dove. It is the type of a distinct family, the

peculiarity of which may be estimated by the discrepancy of opinions respecting its affinities.—R. O.]

Dog and dead game, to illustrate the art of taxidermy in representing life and death.

Arctic foxes (killed at the same season); this group is a striking illustration of the fallacy of the opinion that extreme cold causes the arctic fox and other animals to become white.

Javanese musk deer and young. Male monaul (*Lophophorus impryanus*). A parrot (*Psittacus Leadbeateri*).

Models of eyes for stuffed animals, on a new principle. A leopard (*Felis leopardus*), with the eyes constructed on this principle.

292 WITHERS, W., Devizes, Wilts—Proprietor.
Case of stuffed birds (partridges).

293 BESSANT, MARIA, 5 Union Street, New Bond Street—Manufacturer and Proprietor.

Fancy pincushions; match boxes; porter in his lodge; cradle, &c., manufactured from common egg-shells.

[The employment of egg-shells for ornamental purposes is extremely ancient. A MS. in the Harleian collection represents a number of egg-shells ornamented in the most elegant and costly manner; miniatures were often painted upon them with extreme care, and egg-shells thus curiously decorated became valuable and highly esteemed presents. In Venice, young noblemen frequently lavished large sums of money upon portraits painted within egg-shells, intended as presents.—R. E.]

295 JAMES, JOHN, Victoria Works, Redditch, Worcestershire—Manufacturer.

Glass case, containing every description of needles and fish-hooks. Needle-boxes and needle-books.

Sole inventor and manufacturer of the unique locomotive needles.

297 CHAMBERS, R.—Manufacturer.
Specimens of pins and needles.

301 HERBERT, SARAH, 20 Royal Avenue Terrace, Chelsea—Inventor.

Chepstow Castle, Monmouthshire, by moonlight. Specimen of papyrography, a novel method of representing landscapes, &c., in paper, by the use of the scissors only.

302 RANKIN, EMILY, & LEAR, ELLEN, South Street, Wandsworth—Designers & Manufacturers.
Picture frames of ornamental leather work.

303 PRIDEAUX, Miss, Wellington, Somerset—Producer.
A small basket of rice-paper flowers, cut out with scissors.

304 HARRISON, MARGARET, 19 Bromley Street, Commercial Road East—Producer.
Victoria Regia—wax.
Orchiderus—wax.

305 BARLING, BENJAMIN, & SONS, 142 High Street, Camden Town—Designers and Manufacturers.

1. Silver-mounted meerscham smoking pipe, chased, engine-turned, and engraved top, oak border. Design: A fox and leveret. Motto: "Not caught yet."
2. Silver-mounted smoked meerscham pipe, chased silver. Design: A chamois.
3. Silver-mounted meerscham pipe. Engine-turned, cased, and engraved. Design: A pointer dog and bird.
4. Silver-mounted meerscham pipe. Design: The oak and dolphin (chased).
5. Plain silver-mounted meerscham.
6. Large silver-mounted meerscham courier pipe, pierced and engraved top.

7. A small one, engine-turned top, and chased edge.
8. Another small one, plain polished
All with the registered latch mount, which revolves on a pin.

305A GIBBS, DAVID & WILLIAM, *City Soap Works*—
Inventors and Manufacturers.

Perfumed patent Exhibition and inlaid cameo soaps. Naples shaving tablets. Pearl white soft soap. Neutral white soft soap, used by woollen and silk manufacturers for their finest goods. Soap used chiefly by silk dyers to give gloss and brilliancy to their colours. Black soft soap, used for scouring coarse wools and carpets.

[The admirable researches of M. Chevreul have furnished us with accurate ideas as to the true nature of soaps. They are true chemical compounds of fatty acids with the alkalies, potash or soda. Purity of the ingredients is essential for the finer sorts of soaps, but the commoner are made of all kinds of fatty substances.—R. E.]

306 MORLAND, J., & SON, *50 Eastcheap, London Bridge*—
Manufacturers.

Specimens of umbrellas and parasols.

307 ADAIR, B., *Workington*—Manufacturer.

Specimens of hair watch guards.

308 BARRETT & SON, *Beech Street, Barbican*—Producers.

Glass's patent machine for sweeping chimneys.

309 BURCH, C. & SON, *32 Platt Terrace, St. Pancras Road*—Manufacturer.

Solid rosewood box, glass top for ornamented pencils, embellished with projecting brass ornaments and screws of the Elizabethan style. The pencils are stamped in gold and silver with various devices.

311 PEARCE, T. B., *Newman Street, Oxford Street*—
Inventor.

Self-acting fishing-rod, by which many lines can be used at the same time. This invention is also applicable for sea-fishing, with a variety of newly-invented fishing tackle, &c.

312 AGGIO, GEORGE H., *Colchester*—Designer and
Manufacturer.

Ottoman, novelty in work and pattern.

313 HODGE, W., *34 Great Marlborough Street, St. James's*—
Manufacturer.

Victoria cabinet writing-case, in morocco, ornamented. Album, in ornamental morocco leather.

315 STIRLING, THOMAS, sen., *Bow Bridge Slate Works, Stratford, Essex, and 38 New Broad Street, City*—
Inventor and Manufacturer.

Economic slate pig-feeding trough, so constructed as to keep each animal's food distinct.

Slate trough for pickling meat, which, by its coolness and impermeability, keeps the brine sweet for a long period.

Enamelled slate chimney-piece, capable of being made of any size or pattern.

Chess and other table tops, of the same material, in imitation of inlaid marbles, and ornamented.

Slate inkstand, ornamented and enamelled.

Slate paste-table and rolling-pin, recommended for gloss,

coolness, sweetness, and cleanliness.

Slate milk-pan, cooler than metal, earthenware, &c.

Samples of patent steam fuel.

[The useful application of slate to various domestic and ornamental purposes is due to the present exhibitor. Many years ago he first introduced his self-acting and rapid ascension water-filters, which have been so generally imitated, and which have been so successful in their application. Soon afterwards he introduced the enamelled and ornamented slate for table-tops, trays, inkstands, finger-plates, and various other ingenious and useful purposes, which have also been very generally and successfully imitated. As these applications have not been secured by patent to the original inventor, it is proper that he to whom they are due should not be forgotten in a notice of the articles now exhibited. Some of the specimens of the ornamented slate-table tops seem to vie with those of the celebrated French porcelain, and they are certainly neither so brittle nor so expensive. For numerous domestic purposes, especially where liquids are concerned, it is quite manifest that slate is vastly superior to iron, tin, or zinc; and with care as to mere breakage, it will last an indefinitely longer time.—R. W.]

316 LUCAS BROTHERS, *113 Aldersgate Street*—Inventor.

Lozenges, ornamentally stamped, representing the name of the lozenge on one side, and on the reverse that of the vendor, with the quantity of medicine each lozenge contains.

317 COCKS, JOHN & CHARLES, *6 Duke Street, Reading*—
Inventors and Manufacturers.

Samples of genuine Reading and Old England sauces.

318 WALKER, J., *56 Shaftesbury Street, New Road*—
Designer and Manufacturer.

London grown flowers, dried, and retaining their natural colours, forming patterns in a maple frame for ornamental decoration, &c.

319 SCHRADER, Miss H., *4 Windsor Terrace, Old Kent Road*.

Beaded purses, head-dresses, &c.

320 HANCOCK, J. A.—Producer.

A collection of stuffed birds and animals.

(*In North Transept.*)

321 BISCOE, Mrs., *Holton Park, Wheatley, Oxon.*

Model of a horse and cart, with plans to explain the formation.

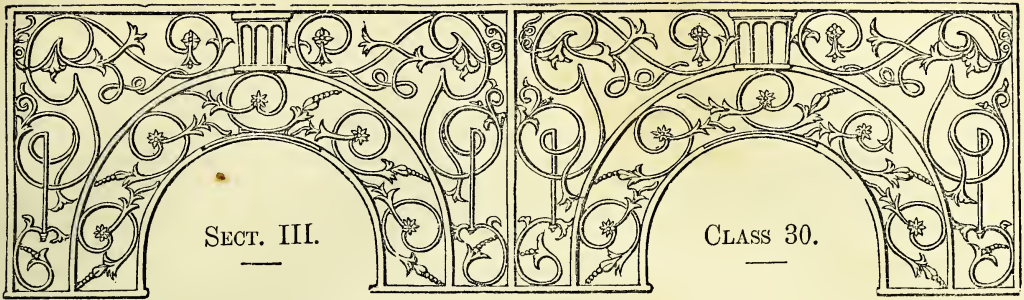

SCULPTURE, MODELS AND PLASTIC ART, MOSAICS, ENAMELS, ETC.

INTRODUCTION.

THE Exhibition having relations far more extensive with the industrial occupations and products of mankind than with the Fine Arts, the limits of the present Class have been defined with considerable strictness. Those departments of art which are, in a degree, connected with mechanical processes, which relate to working in metals, wood, or marble, and those mechanical processes which are applicable to the arts, but which, notwithstanding this, still preserve their mechanical character, as printing in colour, come properly within this Class. Paintings, as works of art, are excluded; but, as exhibiting any improvements in colours, they become admissible. When admitted, they are to be regarded not so much as examples of the skill of the artist, as of that of the preparer of colours. The admission, however, of objects included under the definition "plastic art," has greatly tended to relieve the general aspect of the Exhibition; and their happy and judicious arrangement in the great structure forms one of its most interesting features.

The following Sub-Classes will convey a good general impression of the interesting nature of the objects contemplated under the general terms of Sculpture, Models, and Plastic Art:—A. Recognises Sculpture as a fine art, whether in metals, simple or compound, in minerals, woods, and animal substances, as Ivory, Cameos, &c.; B. Works in Die-sinking, Intaglios, as Coins and Medals, Impressions from Medals, Gems, and Seals; C. Architectural Decorations, integral and adventitious; D. Mosaics and inlaid works in Stone, Tiles, Wood, Metal, &c.; E. Enamels on Metals, China, and Glass; F. Materials and processes applicable to the Fine Arts generally, including Fine Art Printing, Printing in Colours, &c. Of these, as examples, may be mentioned Encaustic Printing, Ornamental Printing, Chromo-lithography, &c., Zincography, and other modes of Printing; G. Models in Architecture, Topography, and Anatomy.

The space in the Building allotted to the objects in this Class is, in addition to that occupied in the Transept and Main Avenues, in two parts of the structure. The Fine Art Court, as it is generally known, is on the North side of the Western Main Avenue, separated from the Transept by the Indian collection, and from the Main Avenue by the articles forwarded from the Channel Islands, Ceylon, and Malta. The Areas here occupied are F. 30 to 32; G. and H. 28 to 32; and I. and J. 28, 29, and 32. The Sculpture Court is in the south of the Main Avenue West, from which it is separated by the Hardware and Mediæval Court; as its name implies, it is exclusively devoted to Sculpture. In the Fine Art Court are grouped together all the other objects representative of the above substances. In the Transept and Western Main Avenue are placed a large number of objects of Sculpture which, from their size, or peculiar fitness for such a position, have not been placed with other specimens of a similar kind in the Sculpture Court.

Sculptures, for obvious reasons, are removed, by their character, from notice in this Introduction. Among the works in die-sinking, attention will be attracted to a collection of the great official seals which affix the emblems of public sanction to national documents. The production of these seals is extremely costly and tedious, and the art they illustrate is one not less demanding the skill of the designer than the nicety and precision of manipulation of the engraver. Methods of producing such seals more economically, and of multiplying them, are exhibited. The application of automatic machinery to this art is of modern introduction. The models for the obverses of the Great Exhibition prize medals are also found in this Court. Some interesting specimens of glass and wood mosaic are also deserving of attention. The brilliancy of the colours of the former material appears to render it very suitable for this purpose. A practical inconvenience, however, often arises from the difficulty of securing the permanent adhesion of the glass to the foundation, which in the instances exhibited appears to have been overcome.

The beautiful art of enamelling is exceedingly well illustrated in this Class by objects of the highest value. The peculiar and difficult processes of manipulation necessary in this art, added to the necessity for skilful treatment of the subject to be painted, render it an occupation confined to a few. Extreme uncertainty often attends the results of the firing through which every enamelled picture has to pass; but, when every step has been successful, and the painter's talent has equalled his skill in manipulation, the result is extremely beautiful and enduring. The most rare metals are often employed in the colours of enamel painting. The material on which the best enamels are painted is gold.

Wonderful progress has been recently made in the art of printing in colours. A most instructive series of these productions is exhibited. Some of them are so arranged so as to exhibit the successive stages through which the print passes, until it is completed in all the colours of an original painting. Steel, wood, and stone, form the materials by which the greater portion of the chromatic prints exhibited have been produced. The characters of the impressions from these surfaces are extremely opposed to each other. Those printed in

oil-colours by a patent process from steel-plates have a sharpness of outline and definition, together with a warmth of tone, which render them somewhat comparable to a good Daguerreotype picture. Those produced by wood-blocks have the closest imitation to water-colour drawings. The outlines are less sharp, and there is much granulous softness in the tones of the production. Specimens of these are inserted with this Class in the Catalogue. The chromo-lithographs are likewise exceedingly beautiful, of great softness of outline, and of considerable depth. To the eye these differences are immediately rendered sensible. The inventor of the art of printing could scarcely have contemplated this application of its principles to the production of coloured pictures.

Elaborate specimens of the art of the wood-carver are exhibited in this Court. Fruit, flowers, game, and other objects, appear in their natural proportions, carved with a degree of delicacy of which the material employed would scarcely appear susceptible. Among other objects of this kind, attention will be drawn to a large oak buffet, with sculptured reliefs, illustrative of events at Kenilworth Castle, the material of which was derived from an ancient tree on that domain; and particularly to the Royal Cradle, exhibited by Her Majesty the Queen, carved in boxwood.

A large number of models of various kinds, architectural, topographical, &c., are placed here. Some of these exhibit the results of a species of industry which steals moments of time from the business of the day, and applies them to the execution of works of the most elaborate kind out of the simplest materials. A very miscellaneous collection of objects will likewise be found and studied with interest in the Fine Art Court.

With the present Class, the arrangement of the Exhibition on the British side is completed. The material, the machine, the manufacture, and the ornament applied, have in succession been brought under consideration. The products of nearly 8,000 Exhibitors have been arranged under these Classes, which may be safely said to represent all that is interesting and valuable connected with the arts of life. Such a collection, made and classified for the first time in this country, must naturally present anomalies and exceptions, and possibly errors of classification. But the general principles laid down have been adhered to, and the result has been the collection of groups of objects which will afford material for study and improvement long after the objects themselves will be removed from this Building. While triumphing in the victories of art and science as accomplished by human instrumentality, may one great result of this Exhibition be not less to inspire gratitude to the Divine source of every good and perfect gift, from whom alone the wisdom to learn and the ability to accomplish have proceeded.—R. E.

FINE ART COURT.

1 MILLER, THOMAS, 56 Long Acre—Inventor and Manufacturer.

Paintings in oil and water colours, showing the application of the exhibitor's silica colours and glass medium; in water colours, by Edward Corbould, Esq.: subject—Britons deploring the Departure of the Romans; in oil, by Edward Armitage, Esq.: subject—Allegory of Peace, commemorative of the year 1851.

A complete assortment of artists' materials.

2 CONCANEN, EDWARD, 427 Oxford Street—Inventor and Producer.

A marine piece, executed in the new style of aerial tinting, which entirely disguises the manipulation, or means of applying colour, and leaves no marks of the hair-tool as in oil-painting, abrupt edges as in water-colours, or marking as in crayon drawings.

3 ROWNEY, GEORGE, & Co., 51 Rathbone Place—Manufacturers.

Colours in use for artistic purposes, in four classes, viz., mineral, animal, vegetable, and native, with the materials from which the manufactured colours are derived. Colours for oil and water-colour painting, in their various forms and modes of preparation. Among them are the following new colours:—Extract of Indian yellow; extract of Italian pink; permanent Italian pink; permanent lake; madderine brown and madderine lake.

Artists' brushes, showing the different stages of manufacture, with specimens of the hair employed, and examples of the various kinds and sizes of brushes in use for artistic purposes. Specimens of black lead, and pencils showing the different stages of manufacture. Specimens of black drawing crayons, of three degrees of hardness.

Mathematical instruments in alabaster, and mathematical rules and scales in various stages of manufacture. A pocket knife adapted for the use of artists. Samples of mastic varnish, and oxidized linseed oil. Specimens of children's water colours, canvas, milled boards, and panels of mahogany and papier maché prepared for oil painting, &c.

[In northern climates, the drying of the oils employed by the artist is much retarded; they are generally heated in contact with some metallic oxide, which, by its presence, enables them to imbibe a certain proportion of oxygen, so as to hasten a perfect resinification. The oil of *sesamum*, under the name of *gingelly*, has been used by the Chinese from time immemorial; this, the *cicinnum* of the Byzantines, has been confounded with castor oil (*ricinum*), which never dries; other writers have taken the *camelina*, which yields this oil, for *chamomile*. Linseed oil superseded this. The use of walnut and poppy oils for the purposes of art can be traced to the beginning of the Christian era. Oils were probably first used, to preserve works of art, as varnishes.—R. HE.]

Statuette, cast in wax composition—"Letting the cat out of the bag," by G. Abbott, sculptor.

Desk for water-colour drawing; when open, it forms a desk, easel, or drawing board, and a stand for the copy.

Specimens of Typo-chromatic printing, invented by FREDERICK W. ROWNEY. This process of colour printing is applied to the production of fac-similes of drawings or paintings. Printing in colours has long been known as applied to ornamental designs, such as illuminated works, fancy title pages, &c., and more recently to coloured prints. These have been done by taking an engraving or print and colouring it by successive printings, which, when completed, produced the appearance of an ordinary print coloured by hand. It is in this particular that the principal distinction exists between the ordinary kinds of printing in colours and the typo-chromatic printing. The latter process proceeding on nearly the same principle as a drawing or painting, viz., by successive printings (as in drawings, by washes) of colour, each one contributing to the form and effect of the drawing or painting intended to be imitated; and the dark finishing touches, which give form and vigour to the subject, being printed towards the last.

Various kinds of printing are made use of, such as copper plate, stone, and block, each possessing some peculiar advantage which renders it preferable in certain effects.



SPECIMEN OF G. ROWNEY AND CO.'S TYPO-CHROMATIC PRINTING.

The liquid look and delicacy of water colours, the granulous softness of the crayon, and the force and texture of oil colour may each be successfully represented by this process. And when time shall have added a little experience and practice to what is as yet a new art, it is expected that works of the very highest excellence may be produced by it. A specimen of this printing is annexed.

The origin of the Guelph and Ghibelline factions, after F. R. Pickersgill, A.R.A.

Westminster Abbey from the park, after R. P. Noble.

The Lake of Lucerne, after T. M. Richardson.

Sleeping and Waking, after J. H. Mole.

The Lesson, after J. H. Mole.

The Gleaners, after U. A. Robinson.

French Fisherman's Daughter, after Lee.

Claine's Church, Malvern Hills in the distance, after R. P. Noble.

5 KEARNEY, WILLIAM HENRY, *Marlborough Cottage, Brompton*—Inventor.

Specimens of crayon painting, executed with the exhibitor's Venetian pastils, and without other aid than the materials shown in the accompanying cases.

By this process pictures, in exact imitation of water-colour and oil painting, can be produced with facility, and are rendered impervious to damp, and adapted for internal decorations.

6 ROBERTSON, CHARLES, & Co., 51 *Long Acre*—Manufacturers.

Canvas prepared with a panel surface, for painting highly finished pictures in oil. Canvas with a drawing paper surface, for landscape painters. Hog and sable-hair brushes. Sable and camel-hair pencils. Water colours in cakes. Water colours in tubes. Portable boxes of materials for sketching from nature, &c. Sketch-book of prepared paper for oil painting, with contrivance for carrying wet sketches.

[Panels, the first grounds for pictures, being liable to accidents of various kinds, were at an early period covered with leather, parchment, or canvas, which were duly prepared to receive oil or *tempera* paintings. The priming of the panel, or canvas, formed one of the most important features in the production of a work of art in both the Greek and Italian schools. Later painters have been more careless of the grounds upon which they painted, and their works have, in many instances, consequently suffered. The attention of artists has been for some time directed to this.—R. HE.]

7 REEVES & SONS, 113 *Cheapside*—Inventors and Manufacturers.

Drawing pencils. Water colours, prepared with wax, &c.

8 GREEN & FAHEY, B. R. & J., 62 *Charlotte Street, Portland Place, and 15 York Place, Brompton*—Inventors.

Folding drawing models, in three series:—advanced, elementary, geometrical; illustrating the application of perspective, and the principles of light and shade.

9 COOK, JAMES EDGAR, *Railway Office, Greenock, Scotland*—Inventor.

Prepared panel of any colour, for amateur painting. The advantages claimed are durability, cheapness, and expeditious preparation, this requiring only a day or two to be ready for the artist.

10 GOVERNMENT SCHOOL OF DESIGN, SOMERSET HOUSE—Producer.

Designs for carpets, drapery, &c.

11 BURROWS, MARY L., 1 *Park St., Islington*—Producer.

Table top, painted on slate.

12 FARREN, M., 32 *Dorset Square*—Designer.

Original design for a bracelet. Strap of "Forget-me-nots."

12A GANN, LOUISA, 31 *Norfolk Street, Strand*—Designer.

Model of a flower vase.

13 SEAGER, W., *Tavistock*—Inventor and Manufacturer.

Model of a geometrical staircase, with a double hand-rail in rosewood; with baluster carved in wood and bronzed; the floor inlaid with different sorts of wood; cornice and columns of the Ionic order, made of sycamore.

14 JIBB, JESSE, 12 *London Street, Fitzroy Square*—Designer and Manufacturer.

Model for an under-spring state carriage, on a scale of $\frac{3}{4}$ inch to a foot.

15 KEPP, R. & E., 40, 41, & 42 *Chandos Street, Charing Cross*—Producers.

Model of the ball and cross of St. Paul's Cathedral.

16 OLIVER, GOLDIENT THOMAS, 22 *Victoria Terrace, St. John's Wood*—Designer.

Device showing the arrangement and combination for harmonizing the colours of flowers in ornamental gardening.

17 PAPERA, JAMES PHILIP, *Clarendon Street, Cambridge*—Sculptor.

Queen Elizabeth, in stone; Sir Robert Peel; The Saviour; Rubens; Vandyke; Oliver Cromwell; King Charles I.; two portraits in marble, &c.

18 LASCELLES, EDWIN, *Wavertree*—Designer and Producer.

Models of Wavertree Church, Wavertree Hall; and farm-houses; Whitechapel. All the figures and animals (150 in number) are carved out of wood.

19 JOHNSTON, GEORGE JOSEPH, *Newmarket*—Producer and Designer.

Boss, frieze, and tablet for a church; and bracket of flowers.

20 SHARP, G., 16 *Wentworth Place, Dublin*—Inventor.

Models for facilitating the teaching and learning the art of elementary drawing.

21 BURNS & PALMER, *Manchester*—Producers.

Models, in plaster, of windows in Sir Benjamin Heywood & Co.'s bank, Manchester: designed by John Edgar Grogan, architect; scale one inch to the foot.

22 UNWIN, W. H., *Sawbridgeworth, Herts.*—Producer.

A tournament of the time of Queen Elizabeth's reign, cut entirely out of plain paper with scissors.

22A PAPWORTH, WYATT, 14A *Great Marlborough Street*—Designer.

Ornamental pavement, in three colours, formed by ten patterns of tiles. Ornamental pavement, in four colours, formed by one pattern of tile. Interior decoration of a saloon. Tea-caddy for papier maché. Chimney-piece for white marble, and cap, full size. Economical carved sideboard and truss, full size. Interior decoration of a room for county meetings.

22B PAPWORTH, JOHN W., 14A *Great Marlborough Street*—Designer.

Candelabrum, "Peace," for gold or silver. Candelabrum, "War," for gold or silver. Decoration of the window side of a sitting-room. Painted glass window in the Italian style, with appropriate furniture. Stamped pattern for druggets. Two ornamental panels for plaster and subsequent painting. Ornament for painted glass. Greek ornamental panel, full size. Italian ornamental panel, full size. The original sketch of the design for the ladies' carpet, exhibited by Her Majesty.

- 23 BURY, RICHARD, 9 *Durham Street, Southsea, Portsmouth*—Producer.
Group of horses, carved in cork. Subject—The story of Mazeppa.
- 25 COSSENS, EDWARD JOSEPH, 15 *Little Queen Street, Holborn*—Inventor and Maker.
Model, in elder-pith, of a sultan and sultana, with male and female attendants. This style of modelling is applicable not only to the production of all sorts of small models, but also of architectural models. The pith for this model was collected in the vicinity of Cheltenham.
- 26 SILLETT, JOHN, *Kelsale, Saxmundham, Suffolk*—Designer.
Model of a ground-floor cottage, designed and built by the exhibitor.
- 27 WITHERS, W., *Devizes, Wilts*—Producer.
Group of stuffed partridges.
- 28 BOND, CHARLES, *Edinburgh, and 53 Parliament Street*—Inventor.
Model of a Highland cottage.—The object of the inventor it to combine simplicity of construction, with comfort, warmth, ventilation, and economy. Adapted to a small farmer, in the Highlands, or in Ireland; it may also be rendered suitable to a weaver.
- 29 FOX, CHARLES, *Brighton*—Designer and Modeller.
Design for a pediment. Subject—Arts, Manufactures, and Commerce promoted.
- 29A FOX, EDWARD, *Brighton*—Designer and Modeller.
Statuettes modelled in plaster: Chaucer and Spencer.
- 30 WYATT, M. DIGBY, 77 *Great Russell Street, Bloomsbury*—Designer.
Various designs for manufactures and decoration. Designs for bookbinding. New combinations, mosaics, and encaustic paving. Frontispieces for works, published for the designer by Mr. Day, of Gate Street, Lincoln's Inn Fields. Stained glass memorial window, &c.
- 31 HARVEY, FREDERICK, 1 *Oriel Street, Oxford*—Inventor.
Easel, for artists sketching out of doors, containing everything required by the artist in colours, slab, pencils, brushes, knife, &c.
- 31A SMITH, HENRY ECROYD, *Saffron Walden*—Proprietor.
Sheets of ancient designs, reproduced for modern ornamental floors.
- 32 PEARCE, EDWARD EDWIN, *Nailsea, near Bristol*—Designer.
Model, in glass, of a house, showing plain brickwork. Another, showing freestone work.
- 33 CALDWELL, GEORGE, *Lichfield*—Designer and Producer.
Bas-relief, from Burn's poem of "Tam o' Shanter;" in plaster.
- 34 BROWN, JOHN, 71 *Herbert Street, New North Road*—Designer.
Drawing-book, with an explanatory pamphlet, intended to introduce a more efficient system of teaching in elementary schools. The subjects are selected and arranged with a view to disseminate a knowledge of ornamental art and to prepare pupils for Schools of Design.
- 35 LIMNER, LUKE—Designer and Producer.
Shaksperian shield.
- 36 CORNS, W., *Waterloo Place, Edinburgh*—Manufacturer.
Specimen of bookbinding: showing the process with double-banded sewing, which is requisite where strength is required, as in large Bibles and Prayer-books, and other heavy works of frequent reference.
- Model of modern Jerusalem, showing the city and adjacent country in their present state. Designed for illustrating biblical history in schools, &c.
- 37 STANDIDGE, HARRIET & Co., 36 *Old Jewry*—Producers.
Royal Illuminated Calendar for 1851. The Ten Commandments, illuminated.
A drawing of tessellated pavement found at Leicester, &c. Guerin's patent steering apparatus, printed in colours and tints, by lithography.
- 38 COWELL, SAMUEL HARRISON, *Ipswich, Suffolk*—Producers.
Specimens of anastatic printing, as applied to original drawings or etchings in chalk or ink, maps, ancient deeds, music, letter-press, lithographic printing, wood engravings, archaeological illustrations, railway surveys, MSS., &c.
The peculiarities of anastatic printing consist in being enabled to produce perfect fac-similes from the originals, merely by the application of acids and heavy pressure; whereby all the point and spirit of the original are retained.
- 40 KRONHEIM, J. M., 32 *Paternoster Row*—Engraver and Printer.
Colour printings of illustrated books, tickets, labels, and bands.
The Descent from the Cross, after Rubens, produced entirely by printing.
- 41 DONALDS, WM. JAS. & CHARLES, 29 *Artillery Place West, Bunhill Row*—Designers and Engravers.
Specimens of silver waiters, upon which are engraved groups of flowers; "View of Venice," from a sketch by Lady Morgan; Raphael's "Paul preaching at Athens;" Etty's "Triumph of Galatea;" "A compilation from the Loves of Venus and Adonis," by Franciscus Albanus; Uwins's "Neapolitan first dancing lesson;" the last in a carved wood border of vine, by W. G. Rogers.
Oval trays, engraved with the "Language of flowers," and other designs.
Engraved subjects for dessert plates.—Landseer's "Breakfast;" Homeward and outward bound; York Minster; and several from Canova.
[The exhibitor's object in employing glass is, by protecting the engravings, to induce a demand for a better class of art than is generally adopted.]
- 42 BURKE, THOMAS H., *Bull Head Court, Newgate Street*—Embossor.
Model of the Great Exhibition, fancy stationery, paper ornaments, &c.
- 43 WARD, MARCUS, & Co., 6 *Corn Market, Belfast*—Producer.
Specimen of chromo-lithography; five plates, printed in gold and colours, representing St. Patrick's bell and shrine; being the illustrations of a work printed in Belfast by the exhibitor, and published by T. Hodgson, 13 Paternoster Row, London.
- 44 WILSON, H., *Glasgow*—Producer.
Specimens of ornamental printing.
- 46 VOKINS, J. & W., 5 *John Street, Oxford Street*—Inventors and Manufacturers.
Registered, revolving, double-standard folio-frame.
- 47 RAYNER, ANNE, 15 *Berners Street, Oxford Street*—Designer.
Specimens of diamond engraving upon black marble, as applied to table-tops, letter-weights, &c.
- 48 WOOD, JOSEPH, *York*—Inventor.
York kegs, or barrels, used by sportsmen for carrying wine, spirits, or beer.

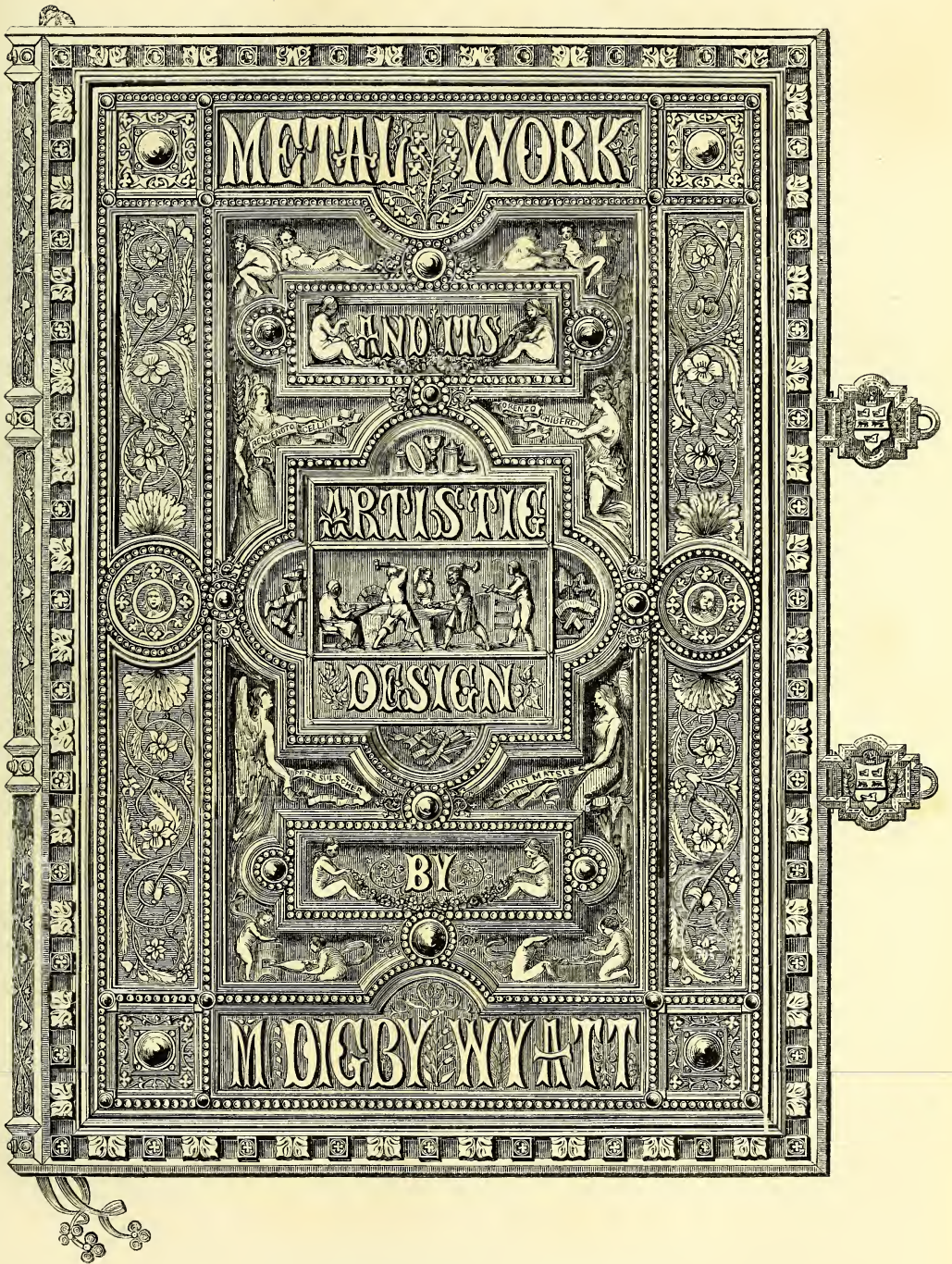

49 **EARLE, JAMES HOWARD**, 50 *Upper Marylebone Street*
—Designer and Painter.
Folding screen—encaustic painting in imitation of antique gems, illustrating the story of Cupid and Psyche. Table-top imitation of buhl.

50 **HUMPHREYS, NOEL HENRY**, 20 *Dorchester Place, Blandford Square*—Designer and Producer.
Specimens of recent progress in decorative printing, and other modes of book illustration, and bookbinding.

52 **BRETT, G.**, 21 *Tysoe Street, Wilmington Square*—Designer.
Onyx gem cameos:—Figure, Cupid and doves; red cornelian. Head of Ariadne, front face; black and white. Head of Bacchantes; red. Head of Goddess of Youth; black and white. Head of Medusa; black and white.

53 **ABBOTT, GEORGE**, 4 *Percy Street, Bedford Square*—Sculptor and Modeller.
Alexander the Great crossing the Granicus. Death of William Rufus.

54 **JONES, OWEN**, 9 *Argyll Place, Regent Street*—Architect.
Printing in colours from stone for illustrated works.

55 **WILSON, ALFRED**, 17 *Queenhithe*—Producer.
Design for a book cover, carved with a penknife; executed in cardboard by Walter Blackett, architect.

56 **HARMER, JAMES, jun.**, 10 *Thornhill Bridge Place, Pentonville*—Designer and Sculptor.
Specimen of sculptured frieze in plaster of Paris.

57 **CROOK, FREDERICK**, 5 *Carnaby Street*—Manufacturer.
A copy of the large white lily, in wrought iron, on stand, with carved iron leafage ornaments.

58 **DUELIN, M.**, 41 *Tottenham Court Road*—Manufacturer.
Specimens of new lithographic coloured printing, chiefly for labels.

59 **LEIGHTON, JOHN**, 40 *Brewer Street, Golden Square, and 19 High Street, Camden Town*—Designer.
Shaksperian Shield—The seven ages of man: a design for basso-relievo, illuminated and mounted as a table top. The accompanying Plate 14 represents this shield. Specimens of trade marks, monograms, and other devices, in various materials.
Specimens of working drawings, designs for medals, a chandelier, book-covers, stamps, &c.
Specimens of ink-lithography, selected from works by Luke Limner.

60 **BURSILL, HENRY**, 9 *York Terrace, Queen's Road, Hornsey Road*—Modeller.
Portrait medallions of Her Majesty Queen Victoria and His Royal Highness Prince Albert.
Selections from the Passions by Le Brun. Modelled in alto-relievo, and produced in infrangible wax, the joint invention of the exhibitor and Mr. G. H. Bursill. The infrangible wax, owing to a slight degree of elasticity, relieves itself freely from the die, whatever may be the extent of the undercuttings.

61 **HELLYER & SON**, *Northumberland Wharf, Blackwall*
—Designers.
Group of seventeen figures, carved in wood; on a pedestal.

62 **FRENCH, CHARLES**, *College, Eton, Bucks*—Designer and Manufacturer.
Two candlesticks, of walnut-tree wood, carved, representing the flowers of the convolvulus and mallow intertwined.

63 **JULLIEN & Co.**, 214 *Regent Street*—Proprietors.
Specimens of ornamental printed music; three of the titles are printed in oil colours, and three printed in colours from stone. The music was engraved on pewter, and afterwards transferred and printed from stone.

63A **LEAKE, FREDERICK**, 9 *Warwick Street, Regent Street*
—Designer and Manufacturer.
Patent relievo leather tapestry hangings, for halls, dining and drawing rooms, and ceilings, in gold, silver and colours, gold lacquer and colours, the old German manner, and grained to imitate woods, &c.—A panel of a room decorated in this style is exhibited in the cut.

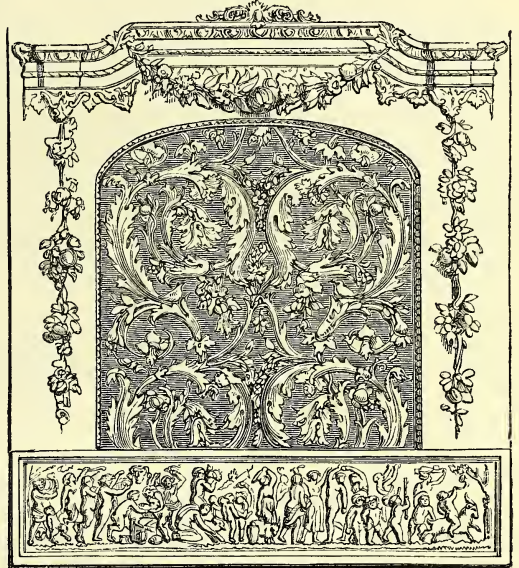

Leake's Patent Relievo Leather Panel.

Cornices for rooms and window decorations in gold, silver, and grained; showing the application of leather for flowers, &c., in the style of Grinling Gibbons' carvings.
Frames of leather foliage, fruit, and flowers, in gold, and colour, and grained in imitation of carvings. Medallion of the Duke of Wellington, and 30 other ornaments in alto-relief.

Furniture, book-case, tables, and chairs, mounted with reliefs in leather. Book-covers in bindings for books, albums, and portfolios; 14 designs.

64 **HANHART, M. & N.**, 64 *Charlotte Street, Rathbone Place*—Producer.

Specimens of chromo-lithography. "The English squire of the last century," executed on stone by John Brandard, from a water-colour drawing by Frederick Taylor; with impressions, illustrating stages of the process of printing.
"The babes in the wood," on stone by the same, from drawings by the Marchioness of Waterford. "The forest farm," on stone by James Coventry, from a painting by T. Creswick. "Landscape, a church," on stone by Noble and Coventry. "Landscape, a mill, North Wales," on stone by the latter, from a water-colour drawing by T. Rowbotham. "Lucerne, Switzerland," on stone by the same, from a water-colour drawing by T. M. Richardson. Intended to show the capabilities of the art for pictorial representations. The novelty is the application of graduated tints.

65 **DAVIS, WILLIAM**, 13 *Osnaburgh Street, Regent's Park*—Designer.

The ascent of Sabrina.—From Milton's "Comus."
The descent of Sabrina.—From Milton's "Comus."
Titania and Oberon. "Come, trip we under the nightshade."—From Shakspeare's "Midsummer Night's Dream."

66 CHAPPELL & Co., 50 *New Bond Street*—
Proprietors.

Specimens of lithographic printing, as applied to music. The illustrations are printed in colours from stone; the music is first engraved on pewter and then transferred to stone for printing.

67 EDWARDS, JOSEPH, 40 *Robert Street, Hampstead Road*—Designer and Sculptor.

Basso-relievos, "The last dream." "Daughter of the dawn." "Medallion of a lady."

68 DICKES, WILLIAM, 5½ *Old Fish Street, Doctors' Commons*—Inventor and Producer.

Various specimens of printing in oil colours from raised surfaces.

69 SOLOMONS, AARON, 22 *Cambridge Square, Hyde Park*—Manufacturer.

An ivory pagoda, after the style of that of Sir William Chambers. This model is turned octagon both within and without. The base on which it is placed is a block of cannel coal. The ornamental tablets surrounding it are produced by the lathe and rose engine.

Two specimens of old engine-turning in ivory, restored and mounted in ebony by the exhibitor.

70 JONES, ARTHUR J., *Stephen's Green, Dublin*—
Designer and Manufacturer.

Suite of sculptured decorative furniture, made of Irish bog yew; with embellishments derived from objects of interest in Ireland, as its monarchs, illustrious characters, historic events, productions, emblems, mottoes, legends, monuments, antiquities, &c. (For illustrations and full description see also Class 26, No. 78.)

71 HULLMANDEL & WALTON, 51 *Great Marlborough Street*—Inventors and Producers.

Sea-piece, by C. Stanfield, R.A., drawn on stone with the stump, and produced nearly in the same manner that a stumped drawing is upon paper with black lead. Landscapes by J. D. Harding, a combination of the stump style and lithographic chalk. The refectory of a Capuchin convent, by G. Cattermole (two copies), produced in lithotint; drawn on the stone with liquid ink and a sable, or camel hair-brush, in the same manner as a sepia or Indian-ink drawing is upon paper. Mollusca, by W. Wing (two copies), in lithotint, and printed in colour. View in Franche Comté, in lithotint, by Louis Haghe. Sea-view and sickroom, by W. Cornwallis Smith, in lithotint. Chateau d'Elz, on the Moselle, and view, drawn by J. D. Harding, in lithotint.

[The art of lithography is indebted to the late Mr. C. Hullmandel for many important inventions. He invented the method of using the "stump," effecting a great saving of labour. To him we owe the "tinted style" and the introduction of "printing in colours." His last invention was the "lithotint," an improvement which had been declared *impossible* by the French Institute.—R. HE.]

72 DEACOCK, E., 26 *Union Street, Middlesex Hospital*—
Inventor.

Working model of a newly-invented mat machine, for wiping shoes.

73 TRUNDLE, MRS., *Cambridge*—Producer.

Wax figures of Her Majesty and Prince Albert.

74 ROGERS, WILLIAM GIBBS, 10 *Carlisle Street, Soho*—
Designer and Producer.

The carved boxwood cradle exhibited by Her Majesty. For description, see No. 353.

Carved glass frame, 11 feet high by 9 feet wide, in lime tree; composed of English flowers, fruits, and insects, mounted upon a moulding of walnut wood, with an arched top.

Trophy, emblematical of "Folly," crowned with oak leaves, &c.

Group of dead game, in a black frame.

Oval frame, carved in boxwood, for Norman Wilkinson, Esq., composed of a wreath of flowers. Bracket, composed of the models of the flowers and fruit introduced in the revedos recently completed for St. Stephen's Church, Wallbrook, by the exhibitor.

Grouse, carved in lime tree; group, intended for a dining-room; cluster of flowers; boss of scroll-work, in the style of G. Gibbons.

Hunting trophy, composed of a boar's head and a horn; carved lobster; groups of fish; and shell-fish and net; intended for the ornamenting of dining-rooms.

Royal trophy, carved in lime tree, upon gold ground. The centre group composed of musical instruments, scrolls, books, palettes, pencils, coronets, sceptres, chains, swores, &c.; in the lower part, medallion portraits of the Queen, &c. The border is formed of groups of game, fruit, flowers, fish, and shells.

Glass frame, composed of English flowers and insects. Oval frame, mounted on a blue velvet ground, of the Venetian school, executed for the Hon. Arthur Kerr, of Worthing. An oval frame, with birds, fruit, and flowers.

Four brackets, carved in satin wood, composed of herons, aquatics, and reptiles. Two brackets, showing a combination of carved wood and porcelain; partly executed by Chamberlain, of Worcester, from models by the exhibitor. Two gilt brackets, executed for P. Gellatly, Esq., of Limehouse. Three brackets of similar character.

Dead game, snipes. Canopy and bracket in the Italian style, to support a thermometer; designed by W. Harry Rogers. Four brackets, masks surrounded by Italian leafage; carved in boxwood for G. Field, Esq. Scroll-work frames, boxwood, mounted on an ebony ground. Elizabethan frame. Italian oval frames, composed of dolphins, flowers, and foliage.

Miniature frame, carved in boxwood, with flowers. Oval frame for miniatures of members of the Royal Family of England: the design purely royal. Border of pinks arranged round an oval moulding. Italian miniature frame. Miniature frame in the style of the period of Elizabeth and James I. Ivory handle for a dessert knife. A paper-knife, carved in boxwood. An Italian mask. Boxwood crosses. Guelder-rose, copied from nature. Anemone and fuschia. A bunch of ivy. Boxwood spoons, Italian style. Orange cup.

Boxwood salt-cellar, enriched with columns, and sunk panels, with spoon; designed by W. Harry Rogers for the Exhibition. Two ring tazzas. Table of inlaid marble, mounted on a carved oak stand. Table cigar box, in boxwood, with foliage, crests, monograms, &c.; executed for N. Wilkinson, Esq. Toilet glass, supported by boys, bearing lights. Base to a carving in bamboo. Carved inkstand, with a stag in the centre, forming a paper-weight, and a cover to the receptacle for seals and wafers.

Carved bread platters, with motto in English, French, and German; selected by Mrs. W. G. Rogers. Lady's work table in satin-wood. The original design, by Wm. Harry Rogers, for the cover of the Bible, carved for Messrs. Nisbet. Bust of Sir Walter Scott, began by Engel, on marble.

Cabinet, made for Stewart Mackenzie, Esq., of Ross-shire, in which are introduced 12 Flemish carvings, with a figure by M. Shee. Boxwood brackets, emblematical of summer and winter.

75 TRUEFITT, GEORGE, 6 *Bloomsbury Square*—
Designer.

Design for a wrought-iron canopied tomb; the roof and coloured parts to be of porcelain, and the figure of alabaster.

76 GRAF, CHARLES, 1 *Great Castle Street, Regent Street*—
Manufacturer.

Lithographic landscapes and architectural views, printed with a single tint, and with two and three tints. Flowers

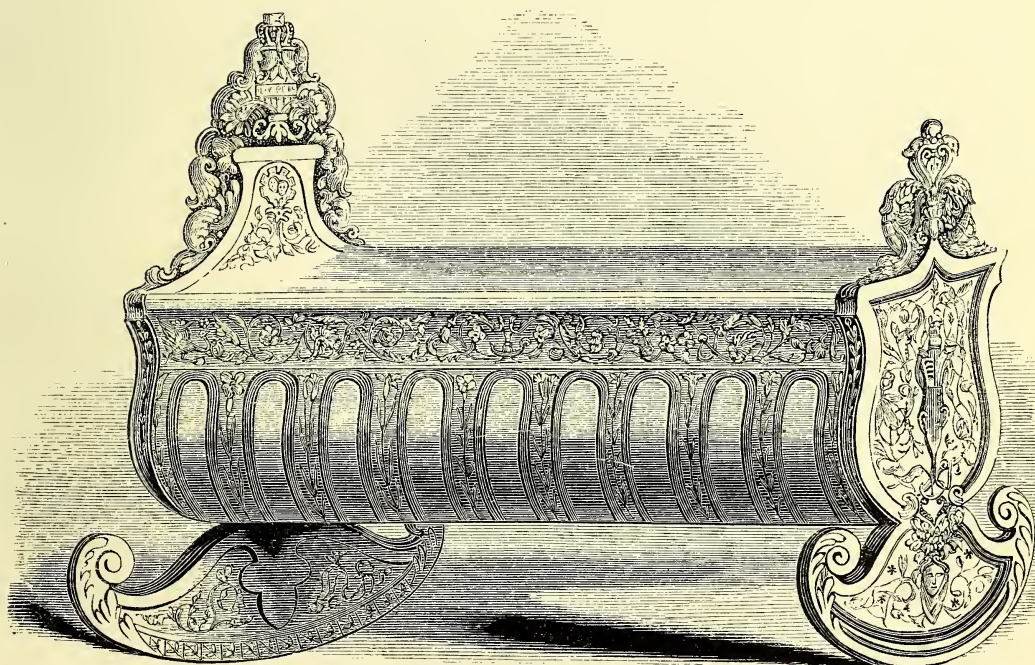
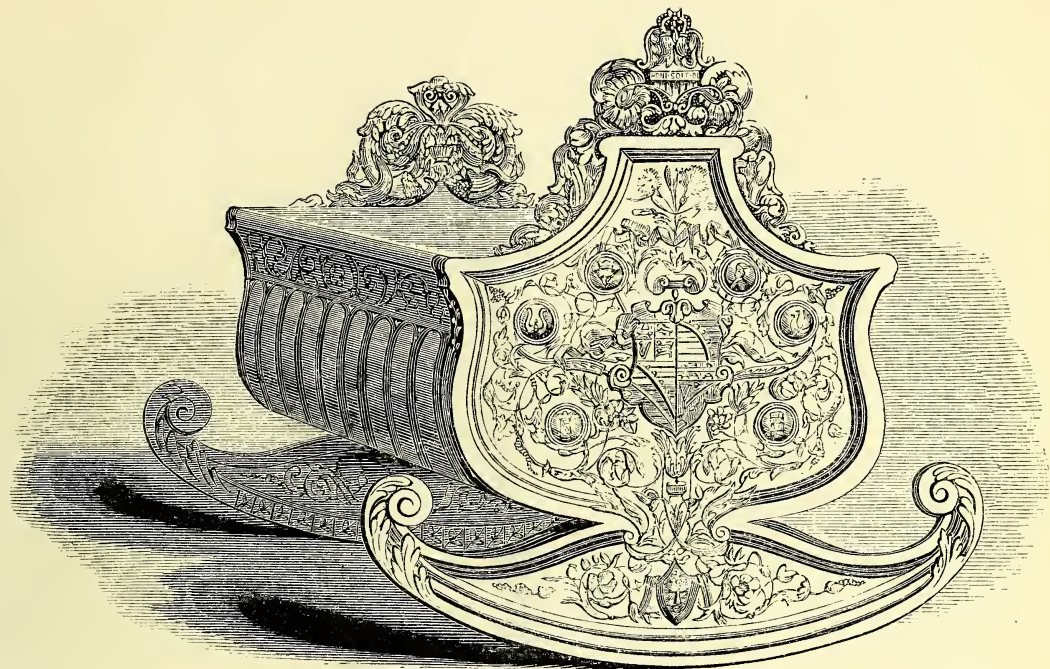

JAPVIS



and vignettes, lithographed and printed in colours. Illuminated prayers, ancient missal style, lithographed and printed in colours. Set of illuminated labels.

77 UNDERWOOD, THOMAS, *Union Passage, Birmingham*—Lithographic and Copper-plate Printer.

Lithographic printing press, exhibiting a new process of producing imitations of water-colour drawings and oil paintings. By this process a great number of good impressions may be taken.

78 LAYARD, CAROLINE MARY, *Bird's Grove, Coventry*—Modeller.

Models of the Nineveh marbles now in the British Museum, by a self-taught relative of Dr. Layard.

79 ALLEN, C. B., 12 *Lower Porchester Street, Hyde Park*—Producer.

Vase in red clay. Design for a monumental cross to the memory of William Caxton, suggested by the Dean of St. Paul's.

80 DAY & SON, 17 *Gate Street, Lincoln's Inn Fields*—Producer.

Specimens of tinted and coloured lithography, or chromo-lithography. The destruction of Jerusalem, and other works, by Louis Haghe.

Tinted views of the Britannia bridge, by George Hawkins. A subject after Chalon, by Edmund Walker.

Plates by Francis Bedford, after drawings by Matthew Digby Wyatt, being illustrations of metal work, &c.

81 GORDON, JAMES, 46 *Park Street, Bristol*—Carver.

Carvings in box-wood. Vase, from the antique; and Belisarius. Anatomical figure in ivory, with supplementary models, intended to show the intricacies of the minute construction of the human body, separately or united. The muscles may be removed or shifted, so as to show the bones, and all the points on their surface to which the tendons are attached. The left side of the figure is composed of imitative bones, muscles, and ligaments. On the right side are the arteries, veins, nerves, and the principal absorbent vessels called lymphatics. The left hand of the figure rests on a small Egyptian obelisk, which serves as a cabinet to hold the slides on which the small models are placed. Without these, the sole of the foot, and other parts, cannot be seen.

82 WILLIAMS, JAMES, 14 *Alpha Road, Regent's Park*—Proprietor.

A Doric column, carved from various natural-coloured woods, in imitation of marble, and ornamented with portraits of three celebrated Italian artists, Raphael, Michael Angelo, and Vitruvius, with their several attributes; upon the base is represented a fly, sculptured in ebony, and the column is surmounted by a statue of Minerva. Artist—Bonzanigo, an Italian.

83 SANGIOVANNI, B., 13 *Clarence Place, Brighton*—Producer.

Terra cotta models of a wild boar; of a group of dogs; and of a stag hunted by dogs.

84 PULLEN, R., *Farnham, Surrey*—Designer.

Basso-relievo in wood, "The Village Dance." Statues in wood, "The Wearied Pedlar," and "The Gipsy Fiddler."

85 MARTIN & HOOD, 8 *Great Newport Street, Leicester Square*—Producers.

Specimen of lithograph, in the style of line engraving, drawn on stone, consisting of landscapes, various styles of architecture, portraits, delineations of subjects in anatomy, armoury, botany, conchology, drapery, embroidery, foliage, geography, hieroglyphics, machinery, &c. The stone from which the above and many thousand impressions have been printed is exhibited in the same frame.

Lithographed fac-simile of Hollar's celebrated four-sheet view of London in 1647, as it appeared before the close of the reign of King Charles the First, and previous to the Great Fire.

86 HARVEY, ARTHUR, *Penzance*—Producer.

Carvings in box-wood; Peter the Great, and Laocoon. Wild sports of the East—Attack of the lion.

87 MITCHELL, JOSEPH THOMAS, *Percy Place, Clapham Road*—Producer.

Specimens of charred chesnut-wood engraving:—"The execution of Saint John," from a mezzotint, by Prince Rupert, in the British Museum.

"The chapeau de brigand," from a picture by T. Uwins, R.A., in the Vernon Gallery.

"The naughty boy," from a picture by Edwin Landseer, R.A., in the possession of John Sheepshanks, Esq.

88 RINGHAM, H., *Car Street, Ipswich*—Manufacturer.

Group of wheat and poppies, carved in lime-wood.

89 WALLIS, T. W., *Louth, Lincolnshire*—Designer and Sculptor.

Spring, represented by the grape-buds and apple-blossoms, with accessories boldly carved. This group is represented in the Plate 107.

A group of dead game—partridge, woodcock, and snipe. The golden plover, with ivy branch.

A group of fruit, flowers, and corn. This group is represented in the following cut.



Wallis's Group of Fruit, Flowers, &c.

The iris plant. A plate of fruit. Carved bread-platters. Each study is from nature, and carved out of solid lime-tree.

- 90 KEHOE, JAMES, *Pole Hore, Wexford, Ireland*—
Designer and Manufacturer.

Registered picture frame, of new design; two twigs are twined together, so as to form the frame, which is executed in Irish bog oak.

- 92 DE GROOT, C., 1 *Swift's Row, Dublin*—Designer and
Manufacturer. Agent in London, J. KENDALL,
8 *Harp Lane, Great Tower Street*.

Basket of fruit, flowers, and ornaments, carved in sycamore; oval picture frame, carved in lime-tree.

- 93 CARRICK, CHARLES, *Canterbury*—Designer and
Manufacturer.

Loo-table slab; inlaid with variously-coloured woods, and interspersed with pieces of whalebone, cane, ebony, &c., forming various devices; among which are two envelopes, with stamps. Another, with 253 different kinds of woods, British and foreign, representing geometrical figures.

- 95 LONGLEY, W. H., 1 *Eaton Place, Park Street,*
Oxford Street—Manufacturer.

Wood-carving, consisting of basket of flowers and two horns of plenty.

- 96 MILLS, ISABELLA FRANCES, *Little Paxton, St. Neots,*
Hunts—Inventor and Producer.

Copies of engravings from Landseer, and others, etched with hot irons. The exhibitor has invented instruments for the execution of works in the pyrographic style (commonly called "poker painting"). Etched by the sole aid of these instruments, drawings may be as neatly executed as with a pencil, and so durable is their nature that they will last until the wood decays. The exhibitor has also succeeded in so preparing the wood as to prevent its warping from the excessive heat necessary. The colouring is entirely the result of heat.

- 97 CALVERT, Rev. WILLIAM, 3 *Great College Street,*
Westminster—Designer and Artist.

Specimen of pyrography, executed upon lime-tree, with a common poker, heated to a red heat. The more delicate shades are produced by moistening the wood before heating. The subject of the design is "Paul and Silas in prison at Philippi."

- 98 WRIGHT, FREDERICK, 23 *Cirencester Place, Fitzroy*
Square—Designer and Sculptor.

Bracket for an oratory, carved in mahogany.

- 99 MILLBANK, D., 10 *Cumberland Place, New Road*—
Producer.

Two inlaid table tops.

- 100 NEWHAM, R., 15 *Blackheath Hill, Kent*—Producer.
Carved writing desk and work box.

- 101 PERRY, WILLIAM, *Bridge Street, Taunton*—Designer
and Executor.

The Taunton vase, carved in a new and simple outline, containing a bunch of roses, executed in box-wood. The body contains an original allegorical composition, divided by trees into two compartments, illustrating the present state of the world, the Great Exhibition of Industry, &c. A group of animals reposing under a fine old oak. The British Lion, the Austrian two-headed Eagle, the Gallic Cock, the Prussian Eagle, and the Russian Bear, for Europe; the Camel, for Asia; the Elephant, for Africa; and the American Eagle. It also contains Britannia, and the "Social effects of the Exhibition." This vase is represented in the annexed cut.

The stand close underneath the body is enriched with chains of corals and jewels, and with the Rose, Thistle,



Perry's Taunton Vase.

and Shamrock, the British flowers; the Lily of France; the Orange, for Italy and Southern Europe; the Sunflower, for Asia; the Tea Plant, for China; the Camellia, for Japan; the Coffee Plant, for Arabia; the Cactus, for Africa; the Epactes, for the Cape; the Indian Corn, for America; the Cocoa Nut, for the South Sea Islands; and the Wheat, for Australia.

Frames for miniatures, showing specimens of carving in its various stages, from the design to the finished article.

- 102 TWELTIDGE, —, *Mansfield, Notts*—Producer.
Carved panel, "Othello."

- 102A WALKER, J., *Groat Market, Newcastle-upon-Tyne*
—Producer.

Carved oak panel, stained as old oak, subject, "Christ blessing little children."

- 103 ESQUILANT, EDWARD, 346 and 541 *Oxford Street*—
Manufacturer.

Leather flowers and fruit, adapted for frames, upholstery, and internal decorations.

- 104 COOK, GEORGE, *Hyde Park Lodge*—Carver.

Piece of carved wood (in lime tree), "Virtue surmounts all obstacles."

Alexander attacking the Persians.

- 105 SUTTON, H., 93 *Vauxhall Street, Vauxhall*—
Manufacturer.

Picture frame, inlaid with tortoiseshell and mother-of-pearl.

- 108 STALON, JOHN, 42 *Berwick Street, Soho*—
Designer and Manufacturer.

Inkstand carved in English walnut.

- 109 BROOKER, GEORGE, 3 *Trinity Street, Cambridge*—
Designer.

Model of 120-gun ship, made of cork.

Design of the great quadrangle of Trinity College.



J. EGLETON. 52

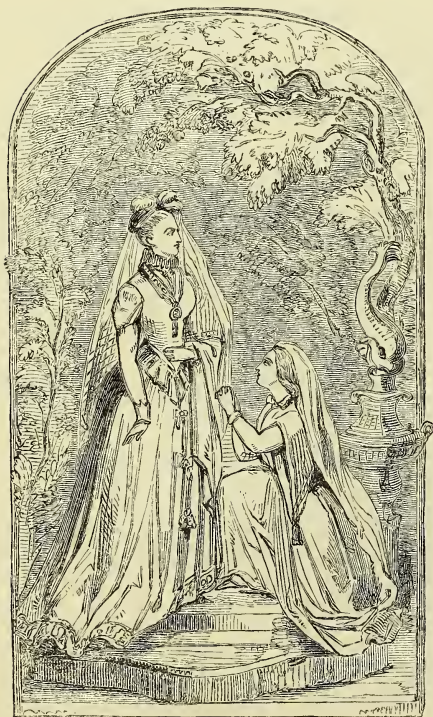

PANELS AND CENTRE COMPARTMENT OF THE KENILWORTH BUFFET, MESSRS. COOKES, WARWICK.

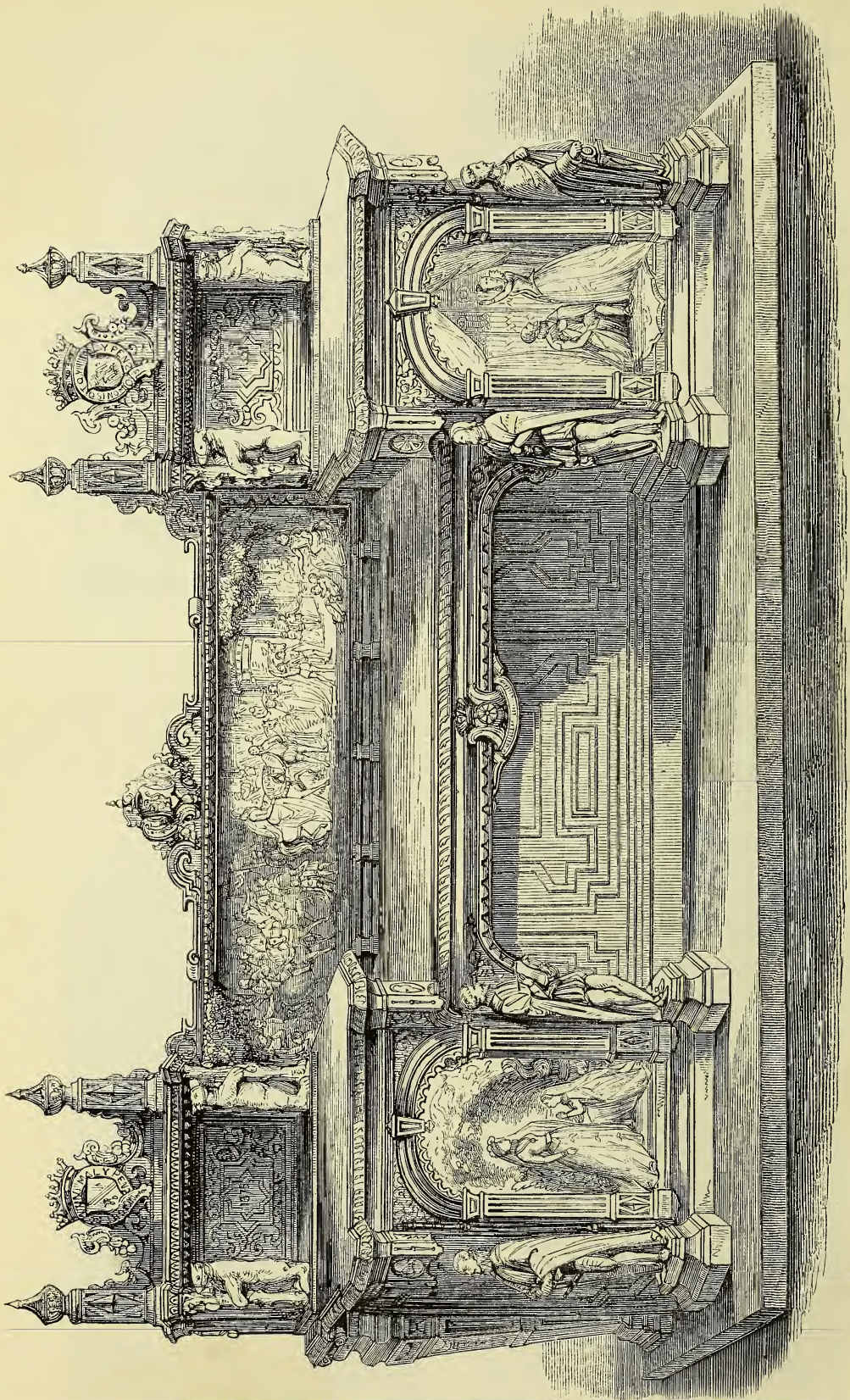

KENILWORTH OAK BUFFET. COOKES AND SONS.

110 COOKES & SONS, *Warwick*—Designers and
Manufacturers.

The Kenilworth oak buffet, with sculptured reliefs, illustrative of events at Kenilworth Castle, from a celebrated oak tree grown upon its domain. The accompanying Plates represent this buffet, 83, 39.

The wood of which this buffet was made was obtained from a colossal oak tree, which grew near Kenilworth Castle, in Warwickshire, measuring 10 feet in diameter, and containing about 600 cubic feet of wood, which was levelled in 1842, and afterwards purchased by the exhibitors. The subject of the design is the Kenilworth Pageant of 1575, in honour of Queen Elizabeth's visit to the Earl of Leicester, described by Laneham and Gascoigne, two attendants on the Queen in this "Royal progress," and vividly reproduced by Scott. The design of the centre panel, carved out of one solid block of oak, represents Queen Elizabeth entering Kenilworth Castle, in all the pomp usually displayed on these occasions. The cavalcade is seen crossing the Tilt Yard, and approaching the base court of the building by Mortimer's Tower. Leicester is bareheaded and on foot, leading the horse upon which his august mistress is seated, magnificently arrayed. The Queen, (then in her 42nd year,) wears her crown, and has around her neck the enormous ruff in which she is always represented. Two pages follow the Sovereign. The Earl of Leicester is dressed in a courtier's garb. A long train of attendants follow the Queen and her host, composed of ladies, statesmen, knights, and warriors; some on foot, others on horseback. In the distance are soldiers and a mixed multitude of people. A portion of the Castle is seen in the back ground. At one end, the gateway through which the cavalcade is about to pass, is Mortimer's Tower, the remains of which are still in existence, and considerably heighten the romantic beauty of the Kenilworth ruins. At the opposite end of the panel, the Earl of Sussex, Leicester's rival in the favour of Queen Elizabeth, is conspicuously seen, mounted on a charger, almost covered with rich trappings, on which are traced his coronet and monogram.

On the table part underneath the centre panel is displayed the Tudor Rose, emblematic of the period, and surmounted by the royal crown, with the famous motto of Elizabeth, "semper eadem," on a ribbon. On the spandrels, supported by water flowers, and rock work pendentives, are marine subjects taken from the 'Pageant,' namely, a Triton on the Mermaid, and Arion on the Dolphin, connected with Mike Lambourne's mishap, in the novel of Kenilworth. The panel on the right, or dexter side of the buffet, recalls the scene in the same work, when Queen Elizabeth meets Amy Robsart in the grotto, in the grounds of the Castle. The subject of the left panel of the buffet, represents the interview of Queen Elizabeth and Leicester, after the exposure of the deceit practised upon her by the latter, and his marriage with Amy Robsart. Leicester is shown in a kneeling position, with one hand on his breast, and the other extends towards Elizabeth, as if appealing to her sensibility. The scene represents a lattice window, and other appurtenances of the window, in the withdrawing room of Kenilworth Castle. The four statuettes at the corners are emblematic of the reign of Elizabeth. These personages have been selected as more prominently adorning the times of this sovereign with their peculiar excellences. At the extreme corner of the right, or dexter pedestal, is represented Sir Philip Sydney, the nephew of the Earl of Leicester, whose character combined all the qualities of a great poet, warrior, and statesman. He died in 1586. He is displayed in armour, typical of the military achievements of Elizabeth's reign, leaning on the sword, and bareheaded. The shape of Sir Philip's sword (which is still preserved at Penshurst) is singular, the handle being about 16 inches long. On the opposite side of the same pedestal will be recognized Sir Walter Raleigh, who attained eminence in almost every branch of science and literature. He is arrayed in a courtier's dress, and the figure represents him in a thoughtful attitude, with a scroll and pen in his hand. Raleigh was beheaded on a charge of high treason in 1618. On the left pedestal at

the inner side of the buffet is a figure of Shakspeare, who is shown in a reflective mood. This great dramatist died in 1616. The last figure is that of Sir Francis Drake, the first Englishman who circumnavigated the globe. An anchor is appropriately introduced, emblematic of his naval career; and the costume chosen is a court dress. Drake died in 1595. The ragged staff mouldings of the Kenilworth buffet are imitations of the best examples in the Beauchamp Chapel, Warwick, where the Earl of Leicester is interred. The supporters to the projecting shelves also represent the proud crest of this splendid noble, the Bear and Ragged Staff, borne by the Earls of Warwick from the most remote times.—The small panels of the buffet behind the Leicester cognizance, contain monograms of the date of Queen Elizabeth's visit to Kenilworth Castle, and the eventful year 1851, with the cipher of the reigning monarch, designed to record the era of the Great Exhibition of all Nations. Around the door panels of the Kenilworth buffet are copies of architectural details still seen on the Gate House, the only habitable portion of the Castle now remaining, and an indication of which may be traced by the introduction of the initial letters R. L. in the ragged staff form, on the spandrels, and which are again observed surmounting the shelves on either side. The upper part above the shelf of each pedestal of the buffet displays the monogram of the Earl of Leicester, encircled by the insignia of the order of the Garter, and surmounted by his coronet, as may be seen on the alabaster chimney-piece in the gate house of Kenilworth Castle.

An important feature in the production of this work of art is the introduction by Mr. Walter Cooper, of *pointing*, employed by stone and marble sculptors, and in this instance successfully applied to wood; by this means greater accuracy in copying from the plaster model has been attained. The decorations on each side are specimens of Elizabethan ornaments, designed by the proprietors.

111 FLETCHER, JOHN, 71 *Patrick Street, Cork, Ireland*—
Designer and Manufacturer.

Gladiatorial table, the pillar represents a fighting gladiator, carved in solid Irish oak; the top, a shield in fancy

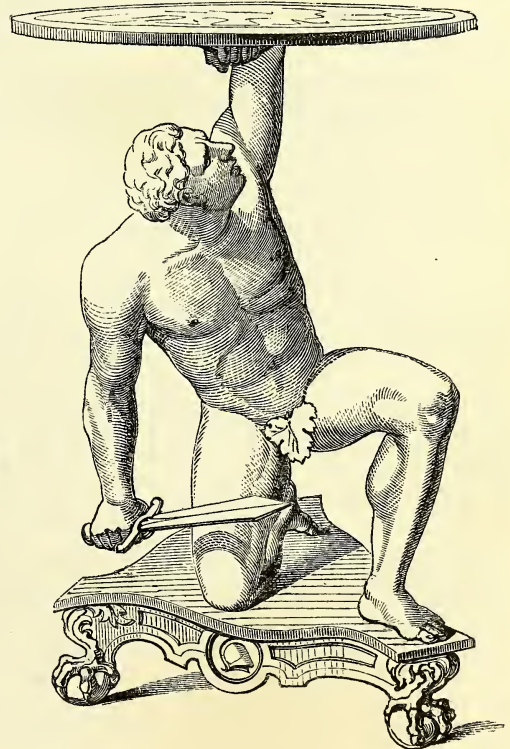

Fletcher's Gladiatorial Table.

pollard oak, relieved by an inlaid border. Registered—
The preceding cut represents this table.

111A BEESON, J., 7 *Wilmot Street, Derby*—Producer.

The "Lord's Prayer" in illuminated characters; consisting of twenty-six different styles of lettering, and surrounded by a massive coloured border. The whole executed in gold and silver bronzes, and brilliant opaque colours, with a common sable pencil.

112 CUNDALL & ADDEY, 21 *Old Bond Street*—Publishers.

Copies of sacred pictures by the old masters, printed with tints, by means of wooden blocks, by Messrs. Leighton, of Lambs-conduit Street.

The Last Supper, by Leonardo da Vinci, drawn on the wood by H. Anelay.

The Holy Family (*La belle Jardinière*), by Raphael d'Urbino, drawn by H. Anelay.

The Descent from the Cross, by Rubens, drawn on the wood by H. Johnson.

The Adoration of the Shepherds, by Rembrandt, drawn on the wood by T. Beech.

Copies of water-colour drawings, printed in colours by means of a succession of wooden blocks, by Messrs. Leighton.

The Gleaner, by William Lee.

The Nut-gatherers, by Edward Wehnert.

The Village Dance, by John Absolon.

Cattle at the Stream, by Harrison Weir.

Specimens of wood-cut printing, by Robson, Levey, and Franklyn, of New Street, Fetter Lane.

113 KING, THOMAS RICHARDS, 5 *Church Row, Islington*—
Inventor and Designer.

Specimen of a new style of painting, invented by the exhibitor and executed in ten hours. This invention consists in the application of finely-pulverised colour to a granulated oil-ground. It is applicable to figures, landscape, fruit, and flowers.

114 LEITH, SAMUEL, 9 *South Street, Andrew's Street, Edinburgh*—Inventor.

A volume, containing specimens of a new process, intended as a substitute for the use of India paper in plate printing.

115 BAXTER, GEORGE, 11 & 12 *Northampton Square*—
Inventor, Manufacturer, and Patentee.

Specimens of patent oil-colour picture-printing—historical, portraits, architectural, and landscapes.

[The delicate and interesting pictures obtained by the means here illustrated, are the result of a skilful system of chromatic printing, entirely different in its character and details to ordinary chromo-lithography. A great degree of depth of tone and of precise and accurate definition of outline is produced, and the colours applied acquire a degree of brilliance and permanency not found in the pictures obtained by the allied art of printing from stones. It is remarkable, also, that the number of impressions capable of being produced appears to be almost indefinite. The same plates are found to be capable of throwing off, with but little attention, hundreds of thousands of impressions, in each of which the accuracy of the outline and gradation of tints is preserved unimpaired. The applicability of the process to the most minute subjects, as well as to those of a larger size, is shown by the specimens exhibited. A series is also exhibited which illustrates the various stages through which the picture passes in the process of receiving its different tints of colour. The delicacy of some of the specimens gives to them a strong analogy to Daguerreotypes, with the advantage of colour and ready visibility at all angles of sight. The economy in production is also an advantageous result of the process.—R. E.]

116 NISBET, JAMES, & Co., 21 *Berners Street, Oxford Street*—Producers.

Bible, bound in wood and leather, with silver-gilt mountings. On the upper panel, from a drawing by Gilbert, Moses is represented pointing the wounded Israelites to the brazen serpent: a symbol which our Lord Jesus Christ appropriated to himself when he said, "As Moses lifted up the serpent in the wilderness, even so must the Son of Man be lifted up, that whosoever believeth in Him should not perish, but have everlasting life."—John iii. 14. This foreshadowing of the Gospel from the base of Mount Sinai, has been selected as an appropriate decoration of a book containing the Old and New Testaments.

The under panel and the border of the upper panel are composed of Italian arabesque, in the style prevalent during the latter part of the seventeenth century, designed by Harry Rogers. The whole carved in box-wood by W. G. Rogers. The binder, Mr. Hayday, has combined the two materials, wood and leather, so as to form a useful and handsome binding. The annexed cut represents the upper panel of this Bible.



Nisbet's Ornamented Bible.

117 MYERS, —, Printers.

Specimen of patent printing, &c.

118 HAMER, M. J., 6 *Kennington Row*—Designer.
Chemical drawing.

119 HARVEY, J. K., 25 *Ely Place, Holborn Hill*.
Designs for carpet, chintz, &c.

120 ROBINSON, FRANCIS K., *Whitby, Yorkshire*—Maker.

Model of the ruins of Whitby Abbey before the fall of the great western window in 1780, and of the tower in 1830. The flat surfaces are cardboard; the ornamental and moulded parts cast in composition, used in making picture-frame ornaments; the pillars and buttresses are wood, and a superior effect has been obtained by the application of string of various thicknesses for mouldings and the bands for the capitals. Length, 4 feet 6 inches.

121 COLLEY, GEORGE, 8 *Upper Dorset Street, Belgrave Road, Pimlico*—Designer and Modeller.

Plaster model representing "The Peaceful Arts triumphant over War;" with a medallion of Prince Albert in the centre.

123 WHITING, CHARLES, *Beaufort House, Beaufort Buildings, Strand*—Proprietor.

Specimens of printing, on the principle of letterpress, entitled "Compound plate printing, cameo embossing, and relief engravings." A compound plate is stated to be capable of printing numerous impressions, without visible deterioration.

[The patents for this invention, which were granted to the late Sir William Congreve, about twenty-seven years since, when it was introduced into H. M. Excise and Stamp Offices for protection against forgery, became the property of the present exhibitor in the year 1830. The Excise permits, the Stamp Office medicine stamps, and the embossed postage stamps, are produced on the principle of these patents.]

124 MITCHELL, SOPHIA ANN, 50 *Wigmore Street, Cavendish Square*—Producer.

Model of a lady in the Court costume of the reign of Queen Victoria.

125 LUMSDEN, I., 8 *Trevor Terrace, Knightsbridge*—Designer and Manufacturer.

Tableau of flowers modelled in wax, in a gilt cornucopia, festooned with acorns and leaves, in a looking-glass frame.

126 SIMMONS, JAMES, 6 *Portobello Terrace, Kensington Park, Notting Hill*—Manufacturer.

Statuary marble work-box, carved in bold relief, with group of flowers on the top, lined with crimson velvet and watered silk.

129 WOLFE, E., & SON, 23 *Church Street, Spitalfields*—Inventors and Manufacturers.

Creta lævis, or newly-invented permanent coloured chalks in cedar pencils; superior to the ordinary crayon, and producing drawings quite equal to water-colour, for depth, brilliancy, and harmonious effect. The drawings made by the creta lævis pencils cannot be obliterated by rubbing, and are not affected by heat or climate.

Registered sketch-book, containing every requisite for the artist, viz.: a solid sketch-block, with drawers for colours, brushes, sketching-pencils, creta lævis or crayons, two dippers, water-bottle, &c.; all in the same size and shape as a common sketch-book.

Athenian crayons and best drawing-pencils, black-lead. Specimens of drawings in the creta lævis. Athenian crayons, and black-lead.

130 WATSON, E. F., 201 *Piccadilly*—Carver and Gilder.
Specimens of gilding, bronzing, &c.

131 BARKER, THOS. JONES, 101 *Stanhope Street, Hampstead Road*—Designer.
The Dying Troubadour. *Vide* Sir Walter Scott.

132 HAWKINS, B. W., 57 *Cambridge Street, Hyde Park Gate*—Designer.

Group in bronze metal of the European bison or aurochs; modelled and chased for presentation to H.I.M. the Emperor of Russia, from the Zoological Society of London. The fox-hunters' candelabra. Model of the anatomy of the horse. Model of a fire-place, composed of metal and porcelain.

133 RICHARDSON, EDWARD, 7 *Melbury Terrace*—Modeller.

William Marshall, Earl of Pembroke in the reign of Henry the Third; John Gower reciting his poems to Richard the Second; horse in full action; all in bronze. Youthful athletæ, in plaster of Paris.

135 HATFIELD, JOHN AYRES, 21 *Cumberland Street, Middlesex Hospital*—Manufacturer.

Bronze bust of Her Majesty, from the original by Sir F. Chantrey. Bronze figure of the "Youth at the stream," from original by J. H. Foley. Boy and girl, from original, in terra-cotta. Fighting gladiator, and Dying gladiator, from antique. Fountain inkstand. Equestrian statue of Napoleon. Figures of Napoleon; Venus at the bath; and Mercury. Pair of candelabra, with boy figure and lily branches. Small vase with sunflower branches, in ornolu.

136 COPLAND, CHARLES, *South Villas, Kennington Oval*—Proprietor.

Fac-simile of the Barberini or Portland vase, moulded at Rome, from the original, by the celebrated seal engraver, Pechler, before it came into the possession of Sir Wm. Hamilton; and taken off by Tassie, the modeller (only a few casts being permitted), when the mould was destroyed. Presented by the late Duchess of Gordon to P. Copland, LL.D.

137 CHRISTIE, A., *Royal Institution, Edinburgh*—Designer.

Twine-holder.

138 SHERWOOD IRON WORKS—Producer.

Casting from an antique statuette of Bacchus.

139 BOOTE, T. & R., *Burslem, Staffordshire*—Producer.

Portland vase, fawn ground, white figures, about 3 feet high: process patented. Vases, groups of flowers, and statuettes, in Parian. Parian bust of Sir Robert Peel, after Sir T. Lawrence. Doric mosaic vases. Azure, Grecian, and fawn jugs, inlaid with white, traced in gold: all by patent process.

140 CONTE, —, 454 *New Oxford Street*—Producer.
Specimens of marble statuary.

140A MASSEY & Co., *Pankhlabanon, 58 Baker Street*—Manufacturer.
Ornamental flower-stand.

141 MABEY, JAMES, 26 *Paradise Street, Lambeth*—Modeller.

Model of a testimonial (in plaster of Paris) to the memory of Henry Handley, Esq., M.P. for South Lincolnshire. Erected at Sleaford in 1850, from the design of W. Boyle, Esq.

142 FOWLER, CHARLES, 1 *Gordon Square*—Producer.

Model of St. John's church, Paddington, executed in card-board by Thomas Dighton, Esq.

143 LEWIS, DAVID, *Ragland*—Modeller.

The remains of the Cistercian Abbey of St. Mary, at Tintern, Monmouthshire, founded A.D. 1131, and completed A.D. 1268. Modelled to a scale of $\frac{1}{4}$ of an inch to 1 foot.

144 PEAKE, CHARLES CORBET, 5 *Grosvenor Place, Camberwell New Road, Kennington*—Designer.

Model in wax of the "Stephanotus" plant, in flower, forming an ornament for a plateau, in the centre of which are the "Graces," supporting a "water lily;" surrounded by figures, in alabaster; the ground arranged with moss and artificial flowers.

145 GILL, G., *New Buildings, Ludlow*—Producer.

Model of the chapel in Ludlow Castle, a copy of the Holy Sepulchre at Jerusalem.

146 CRIBB, THOMAS JAMES, *Kilburn*—Manufacturer.

Working model—landscape to work by clock-work.

147 COCK, H., 6 *Brewer Street*—Manufacturer.

Etching ground. Bordering wax for etching. Two figures in silk.

148 POWELL, J., *Trentham, Newcastle-under-Lyme*—
Producer.

Model of the house in which Shakspeare was born at Stratford-on-Avon, as it now exists, 1851, made of oak and plaster of Paris.

149 WEBBER, JOHN, *Corfe Castle*—Mason.

Design for a tomb in Purbeck stone, on a slab of Purbeck marble.

151 WEIR, JOHN, *56 High Street, Edinburgh*—
Maker.

Correct model of John Knox's house, and part of High Street, Edinburgh, principally of wood, and painted so as to resemble the original.

152 ASHTON, WILLIAM, *154 Sloane Street, Chelsea*—
Producer.

Model elevation of the exterior of the parish church of St. James, Louth, Lincolnshire. Executed by the exhibitor in Bristol card-board, with a pen-knife.

153 WEBBER & BARTLETT, *Bridge Street and St. James' Street, Tunton*—Proprietors.

Model of a cathedral, carved in oak.

154 MALING, —, Producer.

Design for a font.

156 BEAUCLERC, G., *23A Grosvenor Street West*—
Producer.

Specimens of sculpture. Statuettes in Irish clay.

157 BALL, ROBERT, LL.D., *University Museum, Dublin*—
Designer.

Model, being a restoration of the ancient harp, commonly called the harp of Brien Boroihme (Brien Boru) king of Ireland, preserved in the University Museum, Dublin. This restoration is made in the hope of inducing artists to adopt it as a model for emblematical devices relating to Ireland. It is certainly the oldest existing Irish harp; it is supposed to have been figured on the coins of Henry VIII., and in the mutilated state

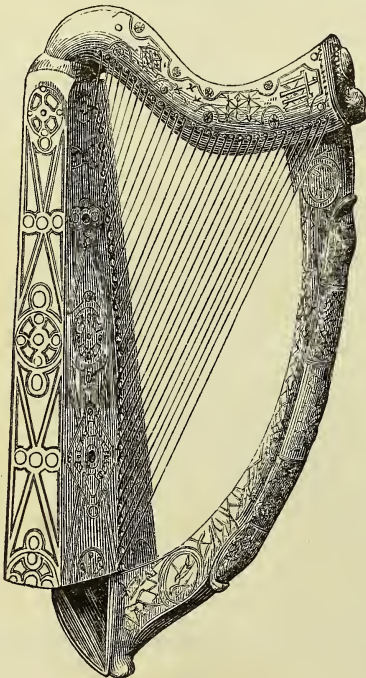

Ball's Restored Brien Boru's Harp.

in which it long remained, it gave origin to the curt and elegant form not unfrequently used in jewellery, &c.

It is now restored to the graceful form it originally possessed, and its elaborate carving has been carefully and accurately restored. The preceding cut represents this harp.

158 STEVENS, GEORGE HENRY, *Stafford Row, Pimlico*—
Designer and Manufacturer.

Pair of candelabra, manufactured in Keen's cement, in imitation of marble, and inlaid with glass mosaic.

Specimen in glass mosaic, of heraldic decoration, to illustrate the working of crests, coats of arms, and of geometrical patterns. This specimen is represented in the Plate 130.

Glass mosaic table-top, on gilt stand, inlaid with mosaic statuary. Marble table-top, on carved walnut-wood stand, both inlaid with mosaic.

159 BRODIE, WILLIAM, *North Street, Andrew Street, Edinburgh*—Designer and Producer.

Group in plaster, "Little Nell and her Grandfather."—See Dickens' "Old Curiosity Shop." Intended for execution in porcelain or bronze.

160 DIGHTON, THOMAS DIBDIN, *2 Great College Street, Westminster*—Producer.

Model of part of the Record Office, in the process of erection, from the designs of James Pennethorne, Esq.

161 MONTEFIORE, SIR MOSES, Bart., *Grosvenor Gate, Park Lane*—Proprietor.

Two vases carved out of a species of sandstone of Jerusalem, with an ordinary penknife, by Mordekhay Schnitzer, an Israelite of that city; height 2ft. 4in., and 2ft. 7in. respectively.

These vases display rich and intricate arabesque carvings, consisting of fruits, flowers, and animals; delicately wrought chains, pendant from the mouths of eagles and lions, and these, though intricately interlaced, yet hanging free, are carved out of the solid block; extended eagles' wings, ingeniously designed to form a base, medallions with a view of the city of Jerusalem, and the armorial bearings of the exhibitor. Hebrew inscriptions, and passages from Holy Writ, in Hebrew, set gem-like, in the buds of roses and other flowers.

161A DAY, RICHARD, *1 Rockingham Place, New Kent Road*—Modeller.

Architectural models—Portico of the Parthenon at Athens, The Temple Church, Fleet Street. Portico of the Pantheon at Rome. The Martyrs' Memorial at Oxford, a modern example of decorated Gothic. Chancel end of a church, decorated Gothic, the window from Herne Church, Kent.

162 WILBY, THOMAS, *St. Bartholomew's Hospital*—Maker.

Model of St. Paul's cathedral in Cardboard.

163 BAINBRIDGE, J., *Gilling, Richmond, Yorkshire*—
Producer.

Model of Clumber House, the country seat of the Duke of Newcastle, in white cardboard, scale $\frac{1}{4}$ of an inch to 1 foot.

164 GORRINGE, WM., *Chichester*—Manufacturer.

Architectural models in paper:—1. Chichester Cross. 2. Monument of King Edward III. 3. St. Paul's Cathedral.

165 GRAINGER, RICHARD, *Newcastle-upon-Tyne*—
Designer.

Models of proposed Town and County Courts, and of the Central Exchange Buildings, Newcastle-on-Tyne.

166 MIDDLETON, JOHN, *Bondgate, Darlington*—
Producer.

Model of York Minster, on a scale of $\frac{1}{15}$ of an inch to a foot.

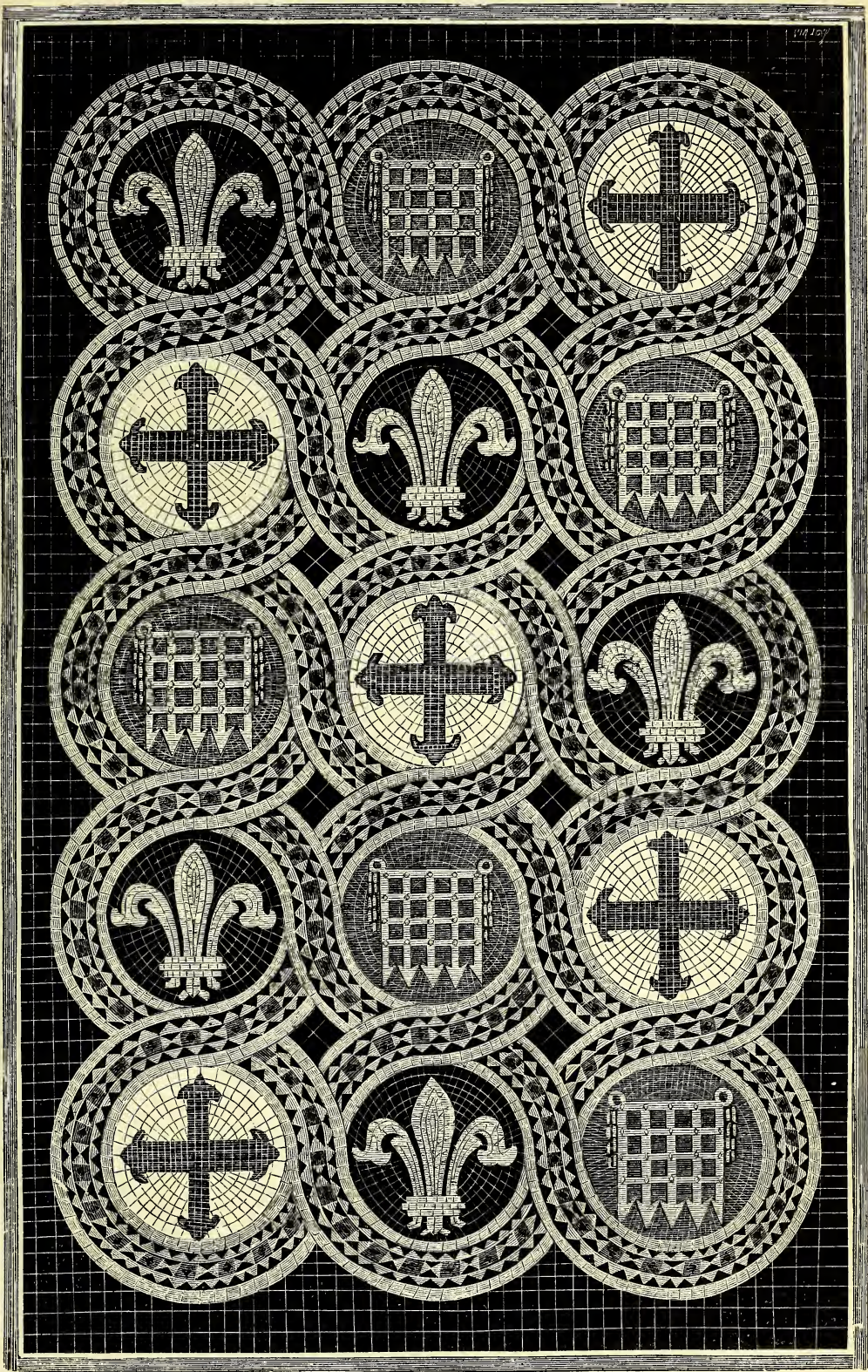

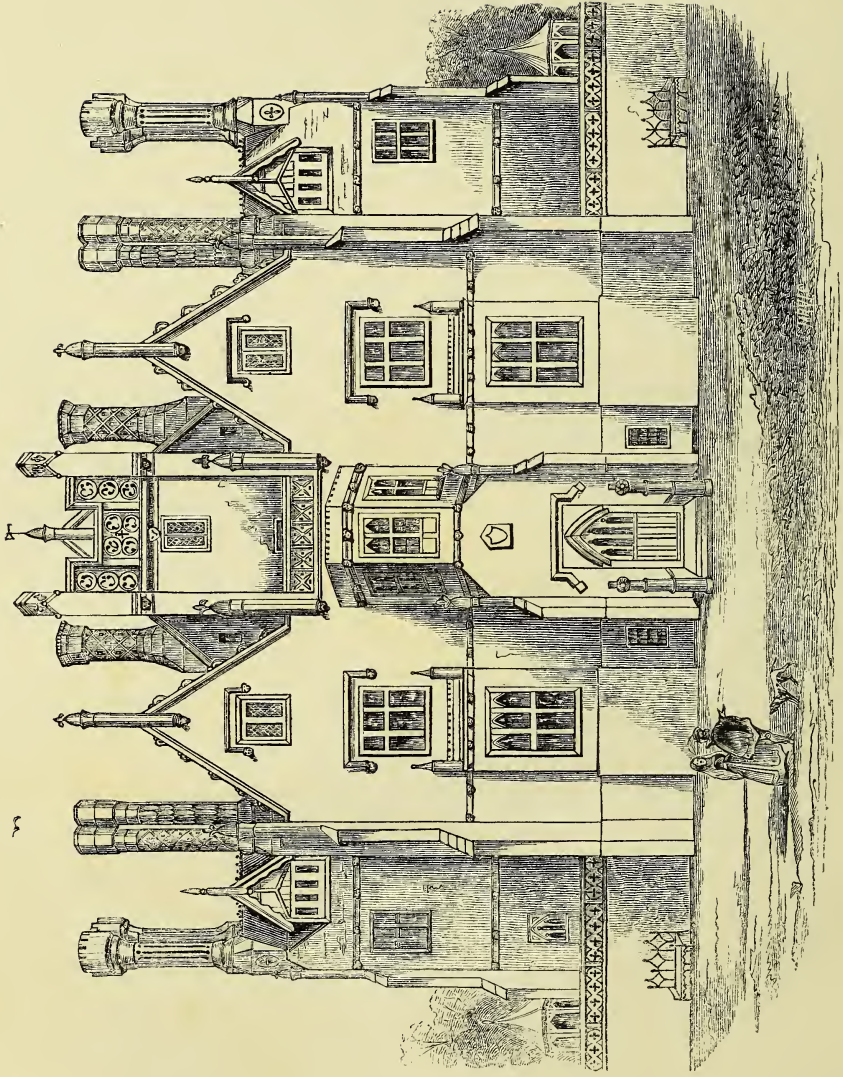

MODEL OF A HOUSE, IN THE TUDOR STYLE, OF PECULIAR CONSTRUCTION, AND ALMOST FIRE-PROOF. W. HARRISON.

167 SMITH, THOMAS, jun., 49 *Eastcheap*—
Manufacturer.

Models in cork:—Royal Exchange, London; Monument, Fish Street Hill, London; scale of the former 1-16th, and of the latter, 1-8th of an inch to the foot.

168 HOARE, MATTHEW, *Langport, Somerset*—
Manufacturer.

Cork model of the Abbey Church, at Bath; scale, 1-18th of an inch to the foot.

169 FULTON, HENRY, *Stillorgan, Dublin*—Designer.

Model of a temple; height of capital, one diameter of column, the other proportions generally the same as in the Roman Doric order.

170 SMITH, SMALLMAN, F., *Stourbridge*—Designer.

Model, in plaster, of a column, from a design for a building for the Great Exhibition. The capital is composed of the letters V. A., and the plume of feathers of the Prince of Wales; the shaft, of a bundle of reeds; the base, of the rose, thistle, and shamrock; and the band, proceeding from the letter A. of the capital.

171 TOBIN, THOMAS, *Ballincollig, near Cork, Ireland*—
Inventor.

Models, in ivory, of the Temple of Neptune, at Pæstum, on a scale of 1 inch to 8 feet; of the ruins of the Temple of Jupiter Stator, in the Forum Romanum, Rome, on a scale of 1 inch to 4 feet; of the ruins of the Temple of Jupiter Tonans, in the Forum Romanum, Rome, on a scale of 1 inch to 4 feet; of Pompey's Pillar, near Alexandria, Egypt, on a scale of 1 inch to 10 feet. The parts of each model cut out of the solid ivory with a lathe. The application of this mechanical power to this particular branch of the art is claimed as original by the exhibitor.

Model, in ivory, of the column of Phocas, in the Forum Romanum, Rome, on a scale of 1 inch to 4 feet.

Bust, in ivory, of Her Most Gracious Majesty Queen Victoria, from a full-sized plaster cast, cut and finished in the same lathe.

172 MERRETT, H. S., 82 *Fetter Lane*—Designer and
Manufacturer.

Model for a general hospital.

173 BALLY, WILLIAM, 54 *King Street, Manchester*—
Inventor and Manufacturer.

Busts in miniature, in illustration of phrenology.

174 WOOD, CHARLES, 31 *Paternoster Row*—
Manufacturer.

Trophy of war, and the four Seasons, in gum paste.

175 BARDWELL, WILLIAM, 4 *Great Queen Street, Westminster*—Designer.

Model from which the design for St. George's Hall, Liverpool, was taken.

Model of a design for a church, similar to that of St. Mary, Temple.

Model of the Labourers' friend Society's cottages.

First design for the improvement of Westminster, in A. D. 1832.

176 SWAIN, T.—Producer.

Model of church and stage coach, in cardboard.

177 COTTON, D., *Longwood, near Huddersfield*—Producer.

Model of the Leeds Industrial Training School.

178 SCOLICK, HENRY CHARLES, *Highgate Lane, Balsall Lane, near Birmingham*—Manufacturer.

Model of St. Paul's Cathedral, made from card-board by a penknife, and containing upwards of 50,000 pieces.

179 LIMEUSE, CHARLOTTE, *Delganey, Ireland*—
Producer.

Models, in elder pith, of Great Cross, Monasterboice; cross of Muiredach, Monasterboice; cross at Clonmacnoise; font of St. Gregory, Norwich; font in Norman style.

180 HARRISON, WILLIAM—Producer.

A model, in card-board, by William Smith, of a house in the Tudor style, designed by the exhibitor. The carcass, including windows and door-cases, was erected wholly of brick and stone, and was completed to the chimney-stacks, without any timber. The roof and floors were framed, and fixed, afterwards, on stone corbels; and the ground-floor made with longitudinal arches of brick, and transverse arches of honeycomb pottery. The upper floors are formed with slate and concrete, each room being surrounded by a brick-wall. The stone staircase was also built simultaneously with the walls, thus rendering the house nearly fire-proof. This house is represented in the annexed Plate.

181 DICKENSON, JAMES, 1 *Waterloo Place, Commercial Road, Limehouse*—Artist.

Model of York Minster in card-board, executed with a penknife. Scale one-sixteenth of an inch to the foot.

182 TITE, WILLIAM, F. R. S., 42 *Lowndes Square*—
Designer.

Model of the portico and west front of the new Royal Exchange in London.

183 WYATT, JAMES, 33 *Dudley Grove, Paddington, and 33 Spital Square*—Sculptor.

Model of Quadriga, consisting of car and four horses, with allegorical figures of Britannia, attended by Peace and Industry, continuing her prosperous career. Designed for a triumphal arch.

184 MILNES, T., *Judd Place East, Euston Square*—
Designer and Sculptor.

Design for an intended monument to the memory of the late Lord George Bentinck. Group of the gamekeeper returning from shooting. Models of a horse and mare. Models of a stag; greyhound and hare; lady's pet dog, cow and calf, bull, two sheep, and a fox's head.

185 MAKEPEACE, ELIZA, 7 *Manor Street, Clapham, Surrey*—Modeller.

Models in wax—the *Lilium lancifolium speciosum*—from a plant grown by Mr. Henry Groom. The *Gloxinia perlyana*—from a plant in the possession of Sigismund Rucker, Esq., Wandsworth, Surrey. The *Cymbidium eburneum*, and *Phalæmopsis amabilis*—from plants in the possession of Conrad Loddiges, Esq., Hackney. The *Rhododendron cuninghamsi*, and improved method of preparing wax for modelling flowers, &c.

186 STIRLING, ELIZABETH, *Mrs. Pinn's, St. Thomas, Exeter*—Designer.

Statuette of Waverley, in ivory.

187 WATKINS, HENRY, *Newport, Monmouthshire*—
Designer and Sculptor.

Group in marble—Death of Llewellyn, the last Prince of Wales.

188 CHRISTIE, J., *Carmylie, Arbroath*—Designer.

Groups in burnt clay, characteristic of the manners and dress of the Scottish peasantry:—A merry making. Group from a funeral. A baptism. A dinner party. A school-master. The village well.

189 ANDERSON, WILLIAM, *County Place, Perth*—
Designer and Modeller.

A Highlander throwing the "putting-stone," standing on a pedestal, on the sides and ends of which are groups of figures in relief, further illustrative of Highland games.

- 190 FRANCHI, GIOVANNI, J., 15 Myddleton Street—
Manufacturer.
Four statuettes in imitation of ivory: Henry VIII.; Queen Elizabeth; Charles I.; and William I. Designed by Charles Grant.
- 191 ROSS, HENRY, 15A Dover Place, Kensington—
Designer.
Statuettes of the Duke of Wellington and the late Sir Robert Peel, Bart.: modelled in wax for Parian and metal.
- 192 DAYMOND, J., 5 Regent Place, Westminster—
Designer and Carver.
Vase with flowers, and sculptured flowers, in marble.
- 193 RITCHIE, JOHN, 92 Princes Street, Edinburgh—
Designer.
Statue in marble of the Duke of Wellington.
- 194 CHEVERTON, BENJAMIN, 38 Camden Street,
Camden Town—Inventor.
Statuettes, busts, and bas-reliefs, in ivory, alabaster, marble, and metal; carved by a machine from originals of a larger size. Those in ivory and marble, not finished by hand.
- 195 LEES, JAMES, Hinchley—Maker.
Model of the stocking-frame introduced into Hinchley, by William Iliffe, in the 17th century, which, with some improvements of detail, is still in use. In front is the workman's seat; opposite him are the needles, receiving yarn from bobbins; and on the minuteness of these needles depends the fineness of the fabric.
The levers are set in motion by treddles moving a pulley, which, aided by the hand, throws the thread into such curvatures as to form loops; another treddle brings down the presser bar upon the hooks of the needles, during which the levers are brought forward by the hands, so as to net the loops previously formed; the process repeated forms a web, and is designated frame-work knitting. The cube of the model is the 200th part of the bulk of the working machine, and the 150th of its weight.
- 196 WORRALL, CHARLES, 20 Little Drummond Street,
Euston Square—Designer and Modeller.
Specimens of modelling and casting.—Lamp, or candelabrum pillars. A font. Tomb of Edward the Black Prince in Canterbury Cathedral. Casts from nature.
- 197 PALMER, WILLIAM, 144 Western Road, Brighton—
Inventor.
Revolving table for modellers, sculptors, statuary; adapted for supporting busts, statues, and wax flowers, or any other article for display.
Callipers, with adjusting screw, for reducing or enlarging to three different scales.
- 199 ALLIN, JOHN, 26 Cannon Street Road East—
Proprietor.
A group modelled in wax, representing Sir Robert Peel and Duke of Wellington on horseback. Designed and modelled by Joseph George Bullock, London.
- 200 WILSON, GEO., at Hine & Addison's, St. Ann's
Square, Manchester—Producer.
Cribbage-board inlaid with the nacre of a species of Pinna from the Pacific.
[Pinna is a genus of bivalve shells allied to the mussel. Large species of it are found in various parts of the world, and one in the British Seas.—E. F.]
- 201 HINE, EDWARD, 2 Orchard Street, Kensington—
Modeller.
Model of a carriage, made entirely of card-board. Every part made to act.
- 202 EVANS, J. H., 2 Kendal Street, New Cross—
Producer.
Models: St. Mary's Church, Whitechapel; Swiss Cottage, at Cranham, Gloucestershire; from an engraving.
- 203 WRIGHT, CHARLES, 8 Torriano Terrace, Kentish
Town—Designer and Modeller.
Statuette of a sleeping babe, modelled from life, and cast in composition, to imitate marble.
- 204 MOSSMAN, WM., 17 Rodney Street, Pentonville—
Designer and Manufacturer.
Perforated note paper, representing the marriage of Cupid and Psyche; embossed.
Model of the building for the Great Exhibition, executed in perforated paper.
Various ornamental lace and perforated papers.
New method and design for decoration of rooms by means of embossed paper laid on in small pieces.
Candelabra in brass, made to take to pieces and form a variety of shapes.
- 205 VINN, THOMAS, 6 Union Walk, Kingsland Road—
Designer.
Specimen of single leaf gilding, imitation or-molu on plaster.
- 206 RUSSEL, G., 4 Dee Street, Aberdeen—Producer.
Snow-ball fight at school, in relief.
- 208 JORDAN, C., Manchester—Producer.
Specimens of ivory balls, turned.
- 208A FOOTS, MRS., 2 Little Chapel Street, Westminster
—Producer.
Specimens of feather flowers.
- 209 WOOD, C. H., 2 High Street, Poplar—Producer.
Specimen of engraving on shell.
- 210 JACOT, H. L., Coventry Street—Designer.
Egg-shells carved with views inside, and others engraved on.
- 211 SMITH, H. A., Caroline Place, Hampstead Road,
Haverstock Hill—Designer and Executor.
Gothic ceiling of the fifteenth century, and a group in plaster; relief book-cover, designed by L. Limmer.
- 212 BAETENS, PAULINE, 18 Oxendon Street, Haymarket—
Designer and Manufacturer.
Pack of miniature playing cards, half an inch in length, painted by hand in water colour, enclosed in a case.
Jenny Lind toilet pincushion and ring stand.
Small work-table, screen, glass, and chair, forming pincushions and needlebooks; the articles all made of English materials.
- 213 SMITH, MARY ANN PELLEW—Designer and
Modeller.
Model of an English "Home," of the 19th century. The villa is completely furnished, to illustrate the home of a small family of fortune, belonging to the middle rank; the individuals are represented by wax figures varying from 3 to 4 inches in height, partly modelled, partly cut out of the wax. Designed and executed by the exhibitor.
- 214 LUNTLEY, J., & Co., New Broad Street Court, City—
Engravers and Printers.
Specimen of machine engraving.
- 215 MORGAN, H. K. G., M.P., Johnstown Castle, Wexford,
Ireland—Proprietor.
Model of Johnstown Castle, county Wexford, Ireland, the seat of the exhibitor. This mansion covers an area

of 188 feet by 133 feet, is built in the perpendicular, pointed, and florid Gothic style of architecture. It was originally an Anglo-Norman keep, and a place of comparative strength.

216 PULHAM, JAMES, *Waltham Cross, Broadbourn*—
Designer and Manufacturer.

Gothic vase of pale red terra cotta. Pedestal for the same of granulated terra cotta.

Specimens of stone-like cement (at the basin of the crystal fountain).

217 HOLDING, MRS. SYBELLA, 31 *Mount Pleasant*—
Liverpool—Designer and Maker.

Pair of wax figures, fancy costume; wax figure of Her Majesty, the drapery and gold trimmings in wax; groups of flowers; and shells in wax.

218 SEAL, JOSEPH, *Worship Street, Shoreditch*—
Producer.

Model in wood, of Crosby Hall, Bishopsgate; built about 1470, by Sir John Crosby, Sheriff of London, and once inhabited by Richard III.

219 FREWER, JAMES R., 105 *Upper Thames Street*—
Designer and Manufacturer.

Model of a gothic conservatory, or fern-house; designed as an ornamental addition to a botanic garden.

220 MECHI, JOHN JOSEPH, *Tiptree Hall, near Kelvedon*,
Essex—Designer

Working model of Tiptree Hall farmery, near Kelvedon, exhibiting the new principle of keeping and feeding animals on open-boarded floors; thus dispensing with the use of straw for bedding, and setting it free for feeding purposes. It also shows the economical application of steam-power to thrashing, grinding, chaff-cutting, dressing, pumping, sack-lifting, and cooking the food for animals. The model is executed by Mr. H. S. Merrett,

82 Fetter Lane, London. The machinery of the model executed by George Frazer Campbell, 17 Addington Street, York Road, Lambeth. The models of animals executed by Messrs. Vincenzo, Ruffoni, and Forzano, 4 Greville Street, Hatton Garden.

221 CAPLIN, J. H. I., *Strawberry Hill, Pendleton*,
Manchester—Designer and Executor.

Topographical oil painting:—Bird's-eye view of the gulf of Naples. An illustrative expression of the laws by which the surface of the earth assumes particular forms.

222 CLIFFORD, WILLIAM, *Exeter*—Proprietor.

Models of the west front of Exeter Cathedral, made of the pith of the common green rush, used in making rush-lights; of the Bishop's throne in Exeter Cathedral; and of Chinese pagodas.

223 GUSHLOW, GEORGE, 34 *Newman Street, Oxford*
Street—Inventor.

Composition table, imitation of bronze, steel, and gold. Plaster casts—Diana, Flora, Warrior, Bull, Greyhound, Dancing Figure, Lions, and relievo, some of which are partly in imitation of bronze, steel, Florentine and antique bronze, and antique copper coloured like bronze. The invention is useful in preserving and hardening the surface of plaster. Plaster casts of Portland vase and Nero cup, frosted silver; these will remain untarnished by the action of the air; group of greyhounds, frosted silver; cartoon imitation of old silver; tortoise, imitation of old silver; frog, silver on bronze leaf.

224 MONTANARI, NAPOLEON, 29 *Upper Charlotte Street*,
Fitzroy Square—Modeller.

Collection of figures, illustrating the different characters of Mexican town and savage life, with their varied costumes and attributes. Twelve civilised Indians of Mexico and its environs, laden with produce and manufactures. Twelve savage Indians, male and female, called *Mecos*, inhabitants of the interior of Mexico. A group of these figures is represented in the following cut.

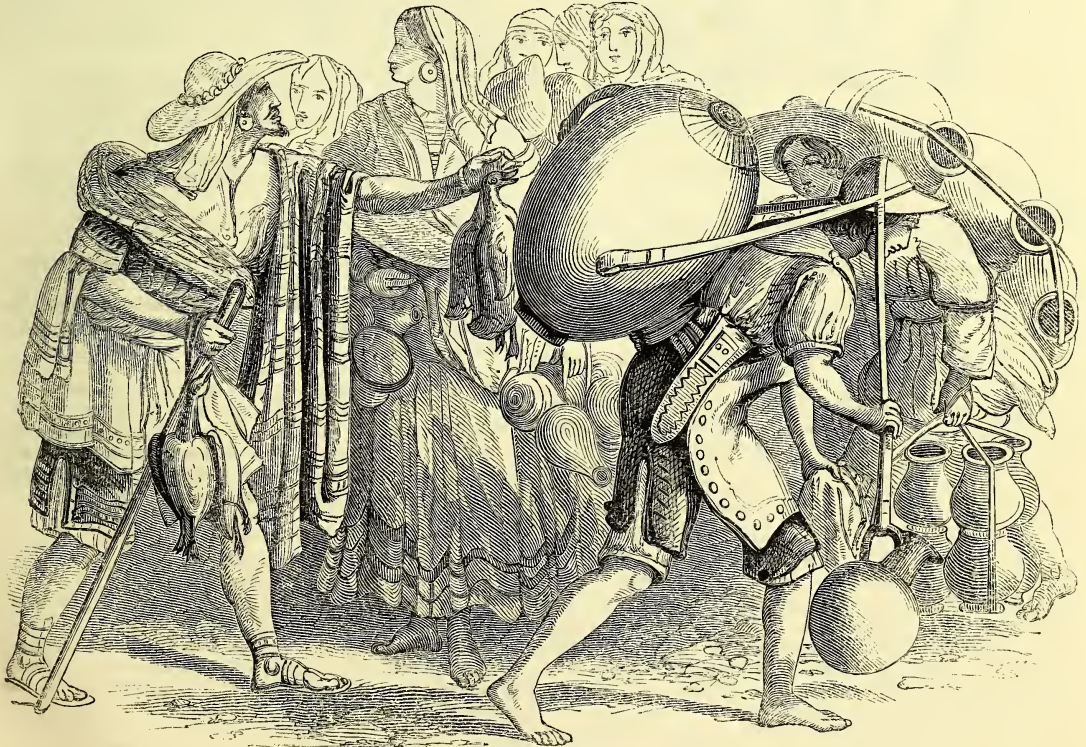

Montanari's Group of Mexican Figures.

Four blacks at different occupations. Court-yard in Mexico; a wealthy farmer and his lady preparing to ride on the same horse, the groom holding the reins. Two groups; one representing the *Ranchero de 1asso*, and the other the *Caporal coleando*. The Fandango, a national dance, a group of three figures. Symbolical figure of Mexico. Group of three Mexican figures.

North American Indian preparing to scalp a white traveller. Anatomical specimen, portraying the last hour of life in consumption (from nature).

Two statuettes of Osceola, the celebrated Seminole chief of Florida, who died in captivity at Fort Moultrie, Charleston. One of these statuettes is represented in the following cut.



Montanari's Statuette of Osceola.

Indian hunting the tiger. Indian carrying away a white child.

225 PIDGLEY, FREDERIC JOHN, *Conniger Cottage, Torre, Teignmouth Rd., near Torquay*—Proprietor.

A plateau, in Florentine marble, of statues, monumental trophies, implements, &c., representing "The fall of Troy, and the Greeks celebrating their victory."

226 BINGLEY, H., 17½ *Kensington Place, Holywell Street, Westminster*—Designer and Manufacturer.

Circular enamelled slate table; decorated in the Etruscan style. Oblong table; antique carved oak stand, enamelled top; after the Etruscan decorations.

Panel containing imitations of marbles in enamelled ate; for chimney-pieces, pilasters, panels, and table ops. Panel containing specimens of colours in enamelled slate; for casing the walls of libraries, halls, dairies, &c.

227 CRADDOCK, THOMAS, *Wisbech*—Producer.

View of Peterborough Cathedral from the east; the west front from market place. Gates entering the Precincts, Peterborough. Porch entrance to Peterborough Cathedral. Mid-gate-street, Peterborough. New iron bridge of the Great Northern Railway, and wooden bridge over the Nare, Peterborough.

Photographic copy of Holloway's print of Raphael's Elymas. Cloisters, Peterborough Cathedral.

Photographic copy of Vandyke's "St. Ambrose refusing Theodosius admittance into the church."

228 CALVERT, W., 43 *Clerkenwell Green*—Producer.

Ornamental engraved zinc plate inlaid with different metals.

228A BULMAN, JOHN, *Kelso, Roxburghshire*—Designer.

Model of a farm steading, erected at Wark, in the county of Northumberland, in the year 1850, on a scale of one-eighth of an inch to the foot; with removable roof, to show the interior arrangements.

The homestead feeds 100 cattle at a time, and has accommodation for young cattle. The stable is fitted up for 24 work-horses. The principal granary is 120 feet by 18 feet, which, with the other granaries, is sufficient to store one-sixth part of the crop. The cart shed is 75 feet by 18 feet. The homestead and stackyard stand on upwards of 3½ acres.

229 CRICHTON, GEORGE, *North Bridge, Edinburgh*—Designer and Manufacturer.

Specimens of Scotch pebble mosaic work; an inkstand, penholder, pencil-case, paper-knife, desk-seal, and paper-weight, mounted in fine gold, and composed of pebbles, jaspers, pearls, and other Scotch gems, showing the most difficult forms of cutting of which these stones are capable, and including all the most rare specimens hitherto discovered. The pearls are from the Tay; the gems from Cairngorm Hill; the jaspers from Arthur's Seat, Kinnoull Hill, Montrose, the Ochill Hills, and other districts of Scotland.

[Jasper, a hard quartz stone of great beauty in some of its varieties, and taking a fine polish, is much prized by workers of mosaic in "pietre dure." The Italians, who chiefly practise this art, have hitherto sought their supplies in Sicily. In the present instance the jaspers have been derived from a source in our own country.]

Work-box, composed of the same stones, in silver mountings, gilt; the cairngorm on the top is large, free from flaws, and of excellent colour.

Two bracelets, composed of Scotch pebbles and gems, in gold mounting. Highland brooch, composed of Scotch gems in gold mounting, with new method of securing the pin.

Specimens of enamelling, applicable to articles of use and ornament: silver claret jug, with enamelled scroll ornaments. The manner in which the enamel is put on secures its durability.

Chatelaines of silver scrolls, ornamented with enamel of various colours; the application of enamel to silver articles of this description is new.

"Albert" shoulder-brooch for Highland plaid.

230 RUSSELL, SAMUEL, 3 *Darnley Terrace, Gravesend*—Inventor.

Specimen, from a print of a line engraving, a fac-simile on steel, from which an indefinite number of fine impressions may be printed.

230A DOWSE, HENRIETTA, 39 *Upper Charlotte Street, Fitzroy Square*—Inventor and Designer.

Illuminated and emblazoned coat of arms and border on vellum by an entirely new process of painting in gold, silver, and colours, with raised work, peculiarly adapted to armorial bearings, illuminated manuscripts, &c.

231 HOLMER, S.—Producer.

Fragments of the Portland vase.

231A HUMPHREYS, JOSEPH, 13 *Howard Street, Strand*—Inventor and Manufacturer.

Portable metallic transparent letters, affixed on glass, for door-plates, stall-boards, and shop windows; these can be transposed and re-arranged without injury to the surface of the glass.

232 ROCHEAD, J. T., *Glasgow*—Designer.

Model of the royal arch at Dundee, erected to commemorate Her Majesty's landing there in 1844 The

design is from the Anglo-Saxon era of architecture; main tower 84 feet; width of structure across the arches, 82 feet.

232A WHISHAW, F., 1 *St. John Street, Adelphi*—
Producer.

Map of London.

233 GREEN, J., 109 *Great Portland Street, Cavendish Square*—Designer and Engraver.

Large military trophy engraved on a zinc plate, 5 feet 7 inches long, by 2 feet 4 inches wide, with bronze frame.

234 ETHERINGTON, H., 2 *West Street, Pimlico*—
Inventor

Two enamelled table-tops, in imitation of glass mosaic work.

235 ALDRED, STEPHEN, 38 *Fetter Lane*—Sculptor.

The Shakspeare Jubilee; each group of figures represents one of the principal scenes in the plays of the immortal bard. Produced during the leisure hours of a working printer.

235A THOMAS, J., 9 *Old Church Street, Paddington*—
Producer.

Design for Preston Hall, modelled by T. Dighton.

236 THOMSON, JAMES, 57 *Devonshire Street, Portland Place*—Producer.

Design for a colossal time-piece, adapted for silver or bronze manufacture, and intended to illustrate the issues of the Divine economy from the creation to the apocalypse, by figures derived chiefly from the works of Michael Angelo, and other masters of the 16th century.

237 HASLEM, JOHN, 1 *Wilton Place, Portland Terrace, Regent's Park*—Producer.

Frame, containing enamel paintings on gold.—1. The Queen in her bridal dress; 2. The Prince of Wales; 3. Prince Alfred, after F. Winterhalter; 4. Princess Feodore of Leiningen, after Steward; 5. Late Dowager Duchess of Saxe Gotha and Altenburg—these five from the collection of H.R.H. Prince Albert. 6. Princess Joinville, after F. Winterhalter; 7. His Grace the Duke of Bedford; 8. Her Grace the Duchess of Bedford, after Catterson Smith; 9. the Marquis of Tavistock, after F. Stone; 10. The late Countess of Harrington, after Cosway, from the collection at Woburn Abbey; 11. Dr. Lyon Playfair.

Three enamels on porcelain.—The Good Shepherd, after Murillo; the infant Samuel, after Reynolds; and Sibilla Eritrea, after Domenichino.

[Gold, of the standard quality, is the best metal to enamel on, as it imparts something of its own glow to the ground, and assists materially the richness and delicacy of the colouring, particularly in the flesh tints. Copper gives a cold greenish hue to the enamel ground, but it is more commonly used than gold on account of its cheapness. For large enamels it is necessary to use copper as they require a heat which would melt plates of gold.]

238 BONE, HENRY PIERCE, 22 *Percy Street*—
Producer.

Enamel paintings on gold.—Landscape after Mola; and Mater Dolorosa after Guido, in the collection of Joseph Neeld, Esq., M.P. Frances, Marchioness of Camden, after Reynolds, and Frank Hals, from the original, by himself, in the collection of Earl Spencer, K.G. Peter the Great of Russia, from the portrait by Kneller, the background by Vandervelde, in the collection of Her Majesty. Judas betraying Christ, after Guido, in the collection of Earl Darnley. Corin and Phileda, original. Infant Saviour, after Murillo, in the collection of Joseph Neeld, Esq., M.P.

239 CHABOT, CHARLES, 9 A, *Skinner Street, Snow Hill*—Designer and Engraver.

Specimens of transfer zincography, and medallion engraving; and of sculpture engraving, produced from the object in perspective by a patent engraving machine.

240 LAING, JOHN, *Calton Hill, Edinburgh*—Designer and Manufacturer.

Glass chess or draught board.

241 ESSEX, WM., 3 *Osnaburgh Street, Regent's Park*—
Painter in Enamel.

Enamel Paintings from Her Majesty's Collection.

1. H.R.H. Prince Albert: from a miniature by Sir W. C. Ross.

2. The late Queen of the Belgians: from a miniature by Sir W. C. Ross.

3. H.R.H. the Duchesse de Nemours: from a miniature by Sir W. C. Ross.

4. Ernest I., Duke of Saxe-Coburg and Gotha; father to H.R.H. Prince Albert: from a picture by Schmiedt.

From H.R.H. Prince Albert's Collection.

5. The Queen: from a miniature by Sir W. C. Ross.

6. The Queen: from a picture by F. Winterhalter.

7. Leopold, King of the Belgians: from a miniature by Sir W. C. Ross.

8. Ernest II., Duke of Saxe-Coburg and Gotha; brother to H.R.H. Prince Albert: from a miniature by Sir W. C. Ross.

9. Prince Frederick Josias, of Saxe-Coburg Saalfeld, Commander-in-Chief of Allied Forces in the Netherlands, in 1792: from a picture by Jagomann.

10. Mary Queen of Scots.

11. Henry VII.: from a picture by Holbein.

12. Henry VIII.: from a picture by Holbein.

13. Edward VI.: from a picture by Holbein.

14. Queen Elizabeth, when 16 years of age: from a picture by Holbein.

15. Queen Elizabeth: from the original by Zucchero.

16. Albert, Prince of Wales, when 16 months old: from a miniature by Sir W. C. Ross.

17. H.R.H. the Princess Royal: from a miniature by Sir W. C. Ross.

18. H.R.H. Princess Helena: from a picture by Winterhalter.

Enamel portrait of Lord Byron: from the original by S. Phillips, R.A.

Enamel portraits of Sir Walter Scott and Thos. Moore, Esq.: from the originals by Sir Thomas Lawrence.

Enamel of the Little Strawberry Girl: from the original by Sir J. Reynolds.

Enamel portraits: Napoleon, by S. Phillips, R.A.; and the Duchess of Northumberland, by Sir T. Lawrence.

The last three are from the collection of the Duke of Northumberland.

Enamel portrait of Milton, when 20 years of age: from the original by Cornelius Jansen, in 1672.

Sir David Wilkie: from the original by S. Phillips, Esq., R.A.

John Gasper Gevartius, a Belgian philologist, born at Antwerp, in 1593: Vandyke—in the National Gallery.

Lady Nugent: from the original by Sir Thomas Lawrence.

Enamel of the Infant Saviour: from the original by Murillo, in the National Gallery.

Enamel portraits of the late Duke of Gordon; (G. Sanders); and the Duchess of Gordon. Both from the collection of the Duke of Richmond.

Marshal Beresford: by G. Sanders; and Viscountess Beresford: by Sir Thomas Lawrence. Both from the collection of H. S. Hope, Esq.

The Duke of Wellington: by Sir Thomas Lawrence. From the collection of the Marchioness of Douro.

Napoleon: from the original miniature by Duchesne. From the collection of Lord Overstone.

Oliver Cromwell: from the original miniature by S. Cooper, in the British Museum. From the collection of Lord Overstone.

Lord Nelson: from the original by Abbot.
Shakspeare: after the Chandos picture by Burbage.
The Hon. Charles William Lambton, eldest son of the Earl of Durham: by Sir T. Lawrence. From the Countess of Elgin's collection.

An enamel of Sancho Panza in the days of his youth: the original by Sir David Wilkie, R.A. From the collection of the Duke of Buccleuch.

An enamel of "Ecce Homo!" from the picture by Guido.
An enamel of the Dog and Fox; the first animals brought from the Arctic Regions, by Capt. Ross.

[A highly-finished enamel is passed through the fire a number of times in the process of painting, otherwise it would be impossible to imitate any great delicacy of tint, as the colours are considerably changed by burning. As the plates are every time subjected to a bright red heat, it is obvious that enamels must be the most durable of all kinds of paintings.—J. H.]

242 CARRICK, THOMAS, 10 *Montague Street, Portman Square*—Inventor and Painter.

Specimens illustrative of the application of white marble as a material for miniature painting; durable, and little affected by light or atmospheric influences. The frame designed and manufactured by Henry Vine, of Albion Place, Little Chelsea.

[This material, not affording food for the development of fungi, is not affected by mildew, neither is its texture altered by variations of temperature.]

243 DE LARA, DAVID, 3 *Alfred Place, Bedford Square*—Designer and Inventor.

Illuminated design on vellum, in colours and gold, 32 inches in diameter; designed in the style of the middle ages, forming a chess-table in the centre, surrounded by arabesque borderings, grouped with flowers, enclosing four pictorial illustrations relative to the game of chess, viz., "the first move," "check," "mate," and "stale mate."

244 HARRIS, JOHN, 40 *Sidmouth Street, Regent's Square*—Producer.

Imitative art in ancient typography.—Specimens of block printing before the use of moveable types; Chaucer, by Caxton, 1st and 2nd editions; Katherine of Sienna, printed by Caxton; Polychronicon, and Promptuarium Parvulorum, by Wynkyn de Worde; English chronicle, by Pynson.

Fac-simile title pages of Coverdale's Bible, 1535; Tyndale's Testament, 2 editions; Tyndale's Pentateuch; and various books of the 16th century.

Specimens of imitative art in illuminated painting.—An elaborate painting on vellum, the border entirely of gold, from an Italian master of the 16th century. Small specimens of Holbein's Dance of Death, finished in opaque colour.

By this method the exhibitor states that accurate specimens of early typography and fac-similes of illuminations can be supplied.

245 GEAR, JOHN WM., 5 *Charlotte Street, Fitzroy Square*—Inventor and Artist.

Specimens of a composition to supersede ivory, for large water-colour paintings, which can be manufactured of any required dimensions, and used for the same purposes as ivory. The colours are described by the exhibitor as holding with tenacity, improving by age, and not fading as on ivory. Illustrated by two paintings.

246 CHESTERS, STEPHEN, 1 *Blomfield Road, Maida Hill*—Producer.

The Holy Family—a specimen of enamel painting on porcelain, after the original picture in the National Gallery, by Murillo.

[The colours used for painting on china are chiefly metallic, and only differ from those used for enamels on metal in having a greater proportion of flux, rendering them more fusible.—J. H.]

247 GOULD, J., 20 *Broad Street, Golden Square*—Inventor.

A new mode of representing the luminous and metallic colouring of the *Trochilidae*, or humming birds.

The effect is produced by a combination of transparent oil and varnish colours over pure leaf gold, laid upon paper prepared for the purpose.

248 COX, GEORGE JAMES, *Royal Polytechnic Institution*—Inventor.

An improved method of transferring copies of delicate copper and steel-plate engravings to the surface of lithographic stone. One copy taken from the steel or copper plate, after being transferred to the stone, is capable of producing 3,000 prints. Stones exhibiting specimens.

249 BELL, W. CHARLES, 44 *Dean Street, Soho Square*—Producer.

Enamel painting on copper, "Ecce Homo," after Correggio.

[The art of enamelling is of great antiquity; indeed, it is impossible to say in what country it was first discovered. It was doubtless practised in Egypt, specimens being found with mummies in that country. It was also cultivated in China, Greece, and Italy. The enamellers of Limoges were famous in the twelfth century, and probably attained their greatest excellence in the sixteenth, under the patronage of Francis I. In modern times, the art has been successfully practised in most countries in Europe, particularly by the Venetians and Genoese.—J. H.]

250 NEWTON, SIR WM. J., 6 *Argyle Street*—Producer.

Pictures painted on ivory, joined together by the artist by a process of his own invention.

1. The Homage, containing the portraits of—Her Majesty.

The late Duke of Sussex; the late Duke of Cambridge.

The Duchess of Sutherland.

The Countess of Gainsborough.

The Bishop of London.

The Marquis of Conyngnam.

The Duke of Richmond.

The late Lord Melbourne.

Viscount Palmerston.

The Duke of Wellington.

2. The marriage of Her Majesty and Prince Albert.

Containing the portraits of—

The late Queen Adelaide.

The late Duke of Cambridge.

The Duchess of Kent.

The late Duke of Sussex.

Lady Adelaide Paget.

Lady Caroline Lennox Gordon.

The late Archbishop of York.

The late Archbishop of Canterbury.

The Bishop of London.

The late Duke of Saxe Cobourg.

The Duchess of Cambridge.

The Duke of Cambridge.

3. The christening of the Prince of Wales in St. George's Chapel, Windsor, containing the portraits of—

Her Majesty and Prince Albert.

The late Duke of Sussex.

The Duke of Cambridge.

Prince Edward of Saxe Weimar.

The late Bishop of Norwich.

The late Archbishop of York.

The late Archbishop of Canterbury.

The late Dean of Windsor.

The Bishop of London.

The King of Prussia.

The late Duke of Cambridge, and

The Duchess of Kent.

251 NICHOLS, MARY ANN, 7 *St. Michael's Terrace, Pimlico*—Inventor and Designer.

Imitation of cameos: new mode of producing likenesses, with portraits in illustration.

252 LAROCHE, MARTIN, 65 *Oxford Street*—Designer and Producer.

Three Daguerreotypes: a composition—"The bath;" a subject—"The evening star;" Daguerreotype as applied to sculpture.

253 DOE, ENOCH, *High Street, Worcester*—Designer.

Specimens of enamelling upon porcelain plates. Scenes from Shakspeare's "Richard the Second." "Royal arms." "Tilting."

254 VOIGTLANDER, EVANS, & Co., 3 *Lowndes Terrace, Knightsbridge*—Proprietors.

Daguerreotype portraits by an improved instantaneous process. Artist, E. T. Pickering.

255 TROTMAN, S., *Clarendon Road, Notting Hill*—Inventor.

Printing on glass for ornamental purposes, such as glazing conservatories, windows, &c.; and for philosophical purposes, such as dissolving views, &c.

256 PRING, DR. JAMES H., *Weston-super-Mare*—Inventor and Designer.

A specimen of ornamental engraving on a plate of hardened polished steel, effected by means of voltaic electricity. Specimens of steel plates, razor and knife blades, steel brooches, &c., in illustration of the method.

[This method of ornamenting is effected solely by means of the electro-magnetic agency, without the intervention of any fluid medium, or the employment of any acid on the object to be engraved. A steel plate, sword blade, razor, or other object to be engraved, is attached by means of a wire to one extremity of an electro-magnetic arrangement, whilst another wire, coming from the other extremity, serves the purpose of the etching or graving tool. The graving wire may be regarded as a pen, charged, however, with the electric fluid in place of ink. One of the advantages of this new application of the electric power is, the extreme whiteness of the mark produced, as compared with the dark surface of the polished steel. This is more conspicuous in the embellishment of any finished article, as a sword-blade, knife, &c. During this process, which may be easily tried by any one, the electrical scintillations produced by the combination of the steel are very beautiful.]

257 BYRN, OSCAR, 9 *Monmouth Road, Westbourne Grove*—Designer and Artist.

Ornamental framework in cork.

258 BREMNER, JAMES, *James Court, Edinburgh*—Designer and Chaser.

Specimens of silver embossed chasing in heraldic and other styles of ornament, intended chiefly to be used for brooches.

Highland ornaments and harness mountings, &c.; Prince Albert's coat of arms, crest and mottoes; crests of Duke of Buccleuch, Marquis of Bute, Earl of Aberdeen, Earl of Breadalbane, Earl of Dalhousie, Earl of Wemyss, and Viscount Palmerston. Other coats of arms, crests, and mottoes. Design for top of a presentation snuff-box; for a Highland belt-plate with crest; for a book-clasp and corners; and for a miniature frame.

259 HASSE, E., *Leeds*—Producer.

Ornamental frame and flowers.

260 YEO, DR. DANIEL, *Ashburton, Devonshire*—Proprietor.

Specimen of oil painting on white velvet, in which the velvet retains its elasticity and softness, and can be washed or brushed, without injury to the painting or fabric. Adapted for chair-covers, and general decoration.

261 GARDIE, LOUIS, 59 *Westbourne Green, Hyde Park Gardens*—Sculptor.

Bronze bust of Sir Robert Peel and the Marquis de la Roche Jacquelin, modelled, cast, chased, and finished solely by the exhibitor.

262 BATSFORD, JAMES, 22 *Stafford Place South, Pimlico*—Sculptor.

The kestrel hawk (*Falco tinnunculus*) and butcher bird (*Lanius*), represented on a bank of earth, from which is springing the coltsfoot plant (*Tussilago Farfura*); executed from a single block of limetree.

263 STAVELEY, THOMAS K., Esq., late Royal Engineers, *Old Stevingford, Ripon*—Painter.

Carte relief map of Linz, Upper Austria, showing the entrenched camp of Maximilian Towers and the surrounding country. Designed by Thomas Firth.

264 BROWN, GEORGE, 25 *Newman Street, Oxford Street*—Designer and Manufacturer.

Figure candelabra, on a dolphin tripod stand, for the drawing-room; the ornamental parts of wood and composition, the figures and dolphins of Carton-pierre; the whole in imitation of or-molu.

265 PULLAN, R. P., 65 *Higher Temple Street, Manchester*—Designer.

Designs for polychromatic decorations, after the manner of the middle ages; showing the effect of the application of positive colours instead of half tints.

Design for the decoration of a chancel in the Romanesque style; of a reredos or altar screen in the Geometric style; of a royal palace in the Tudor style.

266 MORGAN, E., *St. Helen's, Swansea*—Designer.

Topographical model of Tynemouth Castle, representing at one view sections and elevations.

Model of Tintern Abbey, in which sawdust is used to represent ivy or foliage.

267 PLACE, GEORGE GORDON, *Nottingham*—Producer.

Drawings, illustrating "the art of Church Building" in the United Kingdom.

268 BENNETT, EDWARD, C.E., 10 *Great College Street, Westminster*—Architect.

Design for a National Monument to His Royal Highness Prince Albert. The design is square on plan. On the four sides of the elevation above, are four large bronze panel castings in relief, to commemorate the Industrial Exhibition of 1851, and chief events connected therewith, as follows:—

1st. The exterior of the Industrial Exhibition of 1851. 2nd. The interior view of the same. 3rd. The Grand Opening to all Nations. 4th. The Distribution of the Prizes to its Exhibitors.

These four castings in bronze are intended to be twice the size of similar ones on the base of the Nelson Column at Trafalgar Square, and to have sculptured figures in niches on either side, to give the subject of the castings in an emblematic sense, showing the noble intention of His Royal Highness, relative to each; and at the extreme angles of the base, carried out as abutments, are sculptured blocks, upon which are illustrated the emblems of Royalty and Peace.

Europe, Asia, Africa, and America, as emblematical figures, are seated on piers at the four angles of this base; above which, the globe of the earth is represented in polished granite, on which stands a statue of the Prince

in Parian marble, placed in a metal temple, gilt, and dedicated to Prosperity and Fame; with the crown of England above, to denote the Royal auspices under which this Grand Industrial Exhibition has been so successfully accomplished.

269 DRIVER, C. H., 46 West Square, Southwark—
Designer.
Architectural design for a baptistry and font.

270 STOCKER, NATHANIEL BLISS, 7 Charles Place,
Kentish Town—Designer and Proprietor.
Designs for church windows, in which sculpture, &c., is inserted into the tracery. The Commandments are painted on the glass.

271 DICKSEE, JOHN ROBERT, 27 Howland Street,
Fitzroy Square—Producer.
Sabbath Evening, a specimen of chromo-lithography, in six colours.

272 NICHOLL, SAMUEL JOSEPH, 11 Argyll Place—
Designer.
Design for a cast-iron screen to enclose a chapel. In this design an attempt has been made to modify the forms of mediæval architecture, to suit a material the extensive use of which is peculiar to our age.

273 TENNENT, MRS. ROBERT NEILSON, Vale of Health,
Hamstead—Artist.
Miniature portrait. The exhibitor, a self-taught artist, sister of the late Douglas Cowper, S.R.A.
Miniature painting "The Grape Gatherer." Brought from Rio de Janeiro, for exhibition.

274 APPEL, RUDOLPH, 43 Gerrard Street, Soho—
Inventor.
An original print by Albert Durer, representing the "Offering of the Wise Men," date 1518. Plate of the same, with the impression taken by the anastatic process. A copy from the plate.
An original print by Albert Durer, representing the "Nativity." Plate of the same, with the impression taken by the anastatic process. A copy from the plate.
Specimen portrait, printed by the new appolotype process. From the original sketch from life, by Henry Glynn, Esq. Portrait of Alexander von Humboldt, the original from life, by Friedrich Droege, miniature painter to His Majesty the King of Prussia. A landscape by Paul Fischer.
The appolotype process consists in enabling the artist to have his own original sketches and paintings with the brush reproduced in the style of mezzotinto.

275 WARNER, W., 44 Gerrard Street, Soho—Designer
and Producer.
Impressions and casts from intaglios, portraits, figures, seal of the Art Union, &c.

276 MORISON, DAVID, 31 Arlington Street, Mornington
Crescent—Designer.
Coloured wax model of a female hand.
Heads of angels, modelled in wax.

277 SOUNES, JAMES, 49 Rupert Street, Haymarket—
Manufacturer.
Reduced model in wax. Group of animals.

278 BISHOP, J., North Audley Street—Inventor.
Engravings by clockwork, for the prevention of forgery.
Plate or print, containing a large oval medallion of the Queen, with both light and shade, produced by a single line of equal thickness, and 229 feet in length.
Plate or print, containing specimens for bankers' notes and cheques. Plate or print, containing specimens for stamps, &c. Plate or print, containing a bill of exchange in English, and in French, showing that the same design can be repeated.
By this invention an indefinite variety of designs may be produced. Many of these engravings, to the general

observer, have the appearance of engine-turning, combined with that of the relief ruling-machine; but the practised eye may detect the fact that neither rose-engine nor lathe were employed in their production. This machine does not require either patterns or chucks to work from, the various patterns being generated by a moveable train of change-wheels, which, according to their arrangement, produce all the variety of patterns and graduated shades, &c.

279 RUNDELL, W. W., Falmouth—Producer.
Specimens of seals engraved by machine.

280 GIFFORD, JOHN, Royal Polytechnic Institution—
Designer and Artist.
The lion, tiger, elephant, and Alpine goat engraved in cornelian, with impressions.

281 ADAMS, G.—Producer.
Specimens of medals, dies, &c.

282 MARTIN, THOMAS, Newton Abbot—Inventor and
Manufacturer.
Wax impressions of seals engraved by machinery, containing various patterns and sizes of initial, trade, and official seals, in old English, Roman, and Egyptian letters; also "The Lord's Prayer," in English and Latin, each clear and distinct, on a space less than that of a circle a quarter of an inch in diameter. The seals are engraved on brass, and when finished, are mounted on ivory and hardwood handles. The name of the process is "Tornography."

283 COX, HENRY, 6 Upper Southampton Street, Pentonville
—Producer.
Model—"Death on the Pale Horse."

284 WYON, WILLIAM, R.A., Royal Mint—Designer
and Modeller.
Portraits of Her Majesty the Queen and His Royal Highness Prince Albert, being the model for the obverses of the GREAT EXHIBITION PRIZE MEDALS.
Proof coins of the present reign. Specimens of the coins of the two preceding reigns, and of the coins of Portugal, Venezuela, and New Grenada. Models of war-medals, &c.

285 BARCLAY, GEORGE, 22 Gerrard Street—Engraver
and Printer.
Designs for visiting cards, and other engravings.
Specimens of die-sinking, or engraving in metal, and of seal engraving on gems.
Specimens of imitative coins on paper, being impressions of ancient coins, fac-similes of the originals; for the illustration of books, the formation of educational or instructive cabinets, and the completion of scientific collections, by Miss P. S. Barclay.
Specimens of Scripture coins.

286 WYON, LEONARD CHARLES, Royal Mint—
Medallist.
Portraits of the Royal Children; modelled by command of Her Majesty the Queen, in August, 1850.
Model which obtained the prize of 100*l.* in the general competition of designs for the Great Exhibition medals, and, which was adopted by the Royal Commissioners as the second size prize medal.

287 WYON, BENJAMIN, 287 Regent Street—Designer
and Engraver.
Impressions of the great seals of England, Scotland, and Ireland; of the courts of law; the British colonial governments, and various others; and of medal dies.

288 LONGMAN, J. & R., 1 Waterloo Place, Pall Mall—
Designers and Engravers.
Specimens of impressions from seals.

289 KITCHENER, THOMAS, 3 *Little Compton Street, Soho*—
Designer and Engraver.

Seals for Her Most Gracious Majesty; H.R.H. Prince Albert; H.R.H. Albert Prince of Wales; H.R.H. the Princess Royal; the Duchess of Sutherland; the Duchess of Buccleuch; the Duke of Norfolk (official); the Duchy of Lancaster; the Hon. Society of Lincoln's Inn; the Hon. East India Company; and the Goldsmith's Company. Initial letters from the eighth to the sixteenth centuries. Miscellaneous seals, &c.

Sketch, on steel, of a Government official seal.

[By the application of machinery to a die similar to that exhibited, a thousand dies could be obtained, if necessary; so that the whole of the Government official seals and dies might be made eventually at a cost, perhaps, of little more than that of the metal of which they are made.]

289A WOODHOUSE, W., 23 *Molesworth Street, Dublin*—
Engraver.

Bronze medal head of Her Majesty the Queen, struck to commemorate her visit to Ireland; arms of Lords Downshire and Clancarty; impressions in bronze awarded by the Royal Dublin Society, in silver; various medals in bronze and white metal.

Specimens of medal dies made on a new principle, pure cast steel being used, which is more manageable, and, from the smallness of the dies, an economy of material is the result; specimens of dies on the old principle.

290 BUTTERS, L., 41 *George Street, Edinburgh*—
Engraver.

Intaglios, heads of Scott and other eminent men; onyx stones cut as cameos; and specimen impressions of seal engraving.

291 WILBUD, J., 6 *King Street, Snow Hill*—Producer.

Profile bust of Shakspeare, cut from a common plaster of Paris medallion, made to imitate ivory, and equal to it in hardness.

292 WESTWOOD, JOHN OBADIAH, *Hammersmith*—
Proprietor.

1. Electrotpe cast, representing the statue of George III. at Charing-cross, from a die engraved by the late John Westwood.

2. A similar cast, of the statue of the Duke of Wellington at the Royal Exchange, by the same.

3. Specimen of die-sinking in brass, representing the Portland Vase, executed by the same.

4. Another, representing a profile portrait of George IV., executed by the same.

5. Specimens of deeply embossed boxwood (for snuff-box), with bust of George IV., executed by the same.

6. Another, representing the late Marquis of Hastings, by the same.

7. Small frame of buhl work (inlaid brass and ebony), manufactured by the same, containing a bronze medallion of the "Presentation in the Temple," in imitation of the chased work of the Louis XIV. period, also by the same.

8. Three specimens of ivory and ebony knife handles, embossed and studded in silver by the patent process of the late John Westwood.

293 GRAY, ELIZA MARIA, 5 *Charles Square, Hoxton*—
Designer and Manufacturer.

Group of flowers made of human hair.

294 ROUW, PETER, 13 *Denmark Terrace, Islington*—
Modeller.

Medallic portraits, in wax, of the late Matthew Bolton, Esq., Soho; the Princess Charlotte, Mrs. Prodgers, Miss Masters, Stephen Ardesoif, Esq., George the Fourth, Don Miguel, and an infant.

295 SELLERS, J., *Sheffield*—Manufacturer.

Steel plate, size thirty-six by twenty-six and a half inches, machine ruled. Exhibited to show its fitness for the etcher and engraver.

296 HOPLEY, EDWARD, 16 *University Street*—
Inventor.

The triangular, equilateral, and equidistant arrangement of the features; exhibiting a design for a simpler scale of physiognomical measurements, represented in the following cut.

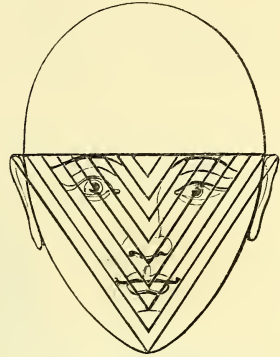

Hopley's Physiognomical Scale.

This is an attempt to enable the statuary or painter, through observing the relation of the features to the facial angles, to realise the proportions of the different parts of the face.

297 MELTON, —, *Edinburgh*—Producer.

Specimens of printing in colours.

298 HARMER, H. R., *Great Yarmouth*—Producer.

Four "sun" pictures of various subjects.

It may be almost regretted that the term "sun painting" has not been substituted for that of photography or light-painting. Many phenomena appear to indicate the existence of at least three distinct principles, or modifications of one principle, in the solar ray—light, heat, and actinism; and those effects upon substances sensitive to impression, by which pictures are produced, are apparently produced principally by the actinic, and not by the luminous or calorific rays. Photographic pictures, therefore, whether on plate, paper, glass, or porcelain, are most properly described as sun-drawn rather than as light-drawn.—R. E.]

299 ROSS & THOMSON, *Edinburgh*—Producers.

Frames containing Talbotype pictures from negatives on albuminised glass.

[The albuminised glass is prepared by mixing a small quantity of iodide of potassium with the white of egg, and uniformly spreading this solution on a glass plate. The thin film being carefully dried, is rendered sensitive by being washed with the gallo-nitrate of silver previously to its being placed in the camera.—R. H.]

300 HILL, DAVID OCTAVIUS, *Calton Hill Stairs, Edinburgh*—
Producer and Designer.

Calotype portraits, individuals, groups, &c. Calotypes of fishermen and women of Newhaven, near Edinburgh. Produced by the exhibitor and the late R. Adamson.

[The calotype process consists essentially in spreading upon paper a uniform film of iodide of silver, and of exciting this by the action of a combination of gallic acid and nitrate of silver previously to its being placed in the camera obscura.—R. H.]

301 BUCKLE, SAMUEL, *Peterborough*—Producer.

A series of pictures from nature, taken by Talbot's photographic process called calotype.

The subjects are in Peterborough and its neighbourhood, and at Bury St. Edmund's. Printed from paper negatives. (*Main Avenue, West.*)

[A paper negative is the picture impressed in the camera. It is so called because the lights and shadows are all reversed in it, that which is shaded in nature being represented in the photograph by light parts, and the reverse. By laying this negative upon a paper covered with chloride of silver, and exposing to sunshine, a correct picture is obtained on the latter. This is called "printing," in the language of photography.—R. E.]

302 BURNARD, NEVILLE, 36 *High Street, Eccleston Square*
—Designer and Sculptor.

Colossal bust—"The Prince of Peace."

303 FOSTER, ERASMUS ROBERT, 1 *Prince's Street, Bank*
—Importer.

An ornamental stone vase, carved out of the rock of Malta, by a native of the island.

304 WILLSON, T., *Crescent Buildings, Leicester*—
Modeller.

Model of the Victoria pyramid—proposed to form the centre of the British metropolitan necropolis, to be erected on Woking Common, in the county of Surrey—in stages ten feet each in height, to be covered externally with blocks of granite. The base to occupy an area of eighteen acres. Its height, when completed, to be 900 feet, and to be capable of containing five millions of coffins, each side of the base measuring 900 feet in length. Designed by J. Willson, Architect, London.

305 CARRUTHERS, WILLIAM, *Reigate*—Sculptor.

Model of the new church at Southwater, Sussex, in Reigate stone. Designed by J. P. Harrison.

306 LUCAS, RICHARD COCKLE, *The Firs, Otterbourne, near Winchester, Hants*—Designer and Manufacturer.

Ivory carvings:—The Nativity; the naming of St. John the Baptist; the Raising of Lazarus; the Descent from the Cross; seal of Richard, Bishop of Durham; the Minerva of the Parthenon; Iris descending; Jupiter; Proserpine; Iris the messenger; Venus and Adonis; Young Apollo; the Graces teaching Love; the Graces; Venus; Ariadne; Galba; Leander.

Imitation bronzes:—Young Bacchus; an athletic figure with a Cæstus; a martyr; Neptune and Minerva of the western pediment of the Parthenon; a study of the Portland vase; Jupiter; Iris; Proserpine.

307 BISS, JOHN, *Bradnich, Cullompton*—Designer and
Manufacturer.

Carved Tudor bed-posts, made of walnut tree, by the exhibitor, a thatcher. The columns are 9 feet high, and 18 inches square at the base, resting on lion's claws; in front is the date, 1851; on the various panels are the Prince of Wales's plume and motto, the crown of Henry VIII., and his queen, Catherine, with the letters H. K., taken from a crown gold piece of that date; the arms of the corporation of Bradnich, and motto; the Queen's crown, with V. R.; the representation of a lamb with six legs, that was dropped on the owner's (H. Matthews, Esq.), property, and is now in good health, with the motto, "Peace and Plenty" (the lamb representing the former, the six legs the latter), and the Tudor rose and motto. Above the squares are several bosses, carved in foliage of oak, ivy, &c., the whole being carved out of solid wood.

308 BAILY & SONS, 71 *Gracechurch Street*—Manufacturers.

Ornamental castings in iron, bronzed. Cast of a fly in bronze, from nature, by W. Midworth, of Mansfield.

309 NORCHI, EGISIPPO, 18 *King William Street, Strand*
—Manufacturer.

1. Bacchanalian vase, in serpentine marble. The Warwick Vase was discovered in the year 1770, whilst excavating and draining the lake called Pantanello, a place anciently situated within the precincts of the Adrian villa, near Tivoli; it was brought to England by Sir W. Hamilton, Ambassador at the Court of Naples, and presented to the Earl of Warwick. The copy here exhibited is an Italian work in serpentine marble, 5 feet 6 inches in height, and 3 feet in width. From two interlaced handles proceed vine branches, which adorn the upper part of this work, illustrating the character of art in the age of Adrian, when the original was executed. A lion's skin surrounds the cup, where heads, masks, thyrsi, and other ornaments consecrated to Bacchus are seen lying. Rich foliage adorns the great body of the vase, which is placed upon a basis resting upon a column, surrounded by a vine branch.

2. Sabina, in serpentine marble, a copy of the celebrated group of Giovanni Bologna da Dovai. This sculptor was a Fleming, employed constantly for many years in Italy. In the base is another group alluding to the same event. The total height is 7 feet 6 inches. See "Bocchi, Beauties of the City of Florence," p. 37, Florentine edition of 1591. Baldinucci, vol. vii. p. 87. Vasari, p. 1113, and elsewhere, Florentine edition of 1832-38. This group is represented in Plate 27.

[Cigoguara says of this artist and his time that a great facility of execution and universal imitation of Michael Angelo, rather than of nature, destroyed the originality. Rapid in execution, lively, a good composer, but affected while seeking grace, and exaggerated to display skill.—H. T. H.]

3, 4. Two large vases in agate, very full in foliage. Bacchanalian masks, composed on the best antique model, 7 feet 6 inches high, from a very ancient jug in bronze, in the Museum at Volterra. One of these vases is represented in Plate 32.

310 AITKEN & ALLAN, 102 *Prince's Street, Edinburgh*—
Designers and Manufacturers.

Pier-table and mirror-frame, in carved wood, with design representing the seasons, Peace, War, Commerce, Navigation, Science, Art, and the general progress of civilization.

311 DE LA BOND, COUNT—Producer.

Specimens of wood carving by machinery.

312 CUFF, R. P., 7 *Owen's Row, Goswell Road*—Producer.

Design for a pendant hall-lamp for gas.

313 AUSTIN, WILLIAM, *Limehouse Dockyard*—Producer.

The "Crucifixion." The object of the artist has been to exhibit, both in the expression of the countenance and the convulsion of the figure, the "Last Agony."

314 CASTLE, J., *Cowley Road, Oxford*—Designer and
Sculptor.

Baptismal font, in Caen stone, enriched with four compositions in alto-relievo, and symbolical decorations of fruits, foliage, &c., studied from nature, and adapted to conventional architectural forms.

315 WILSON, JOHN, 20 *Leicester Square*—Designer and
Engraver.

Red cornelian onyx intaglio, "The parting of Hector and Andromache."

Cameo, of three strata, made to imitate the original in different coloured paxana. The subject—"The marriage of Alexander and Roxana."

316 KAULBACH, EDWARD, 5 *Duke Street, Grosvenor Square*
—Designer and Modeller.

Satan apostrophising the Sun. From Milton's *Paradise Lost*.

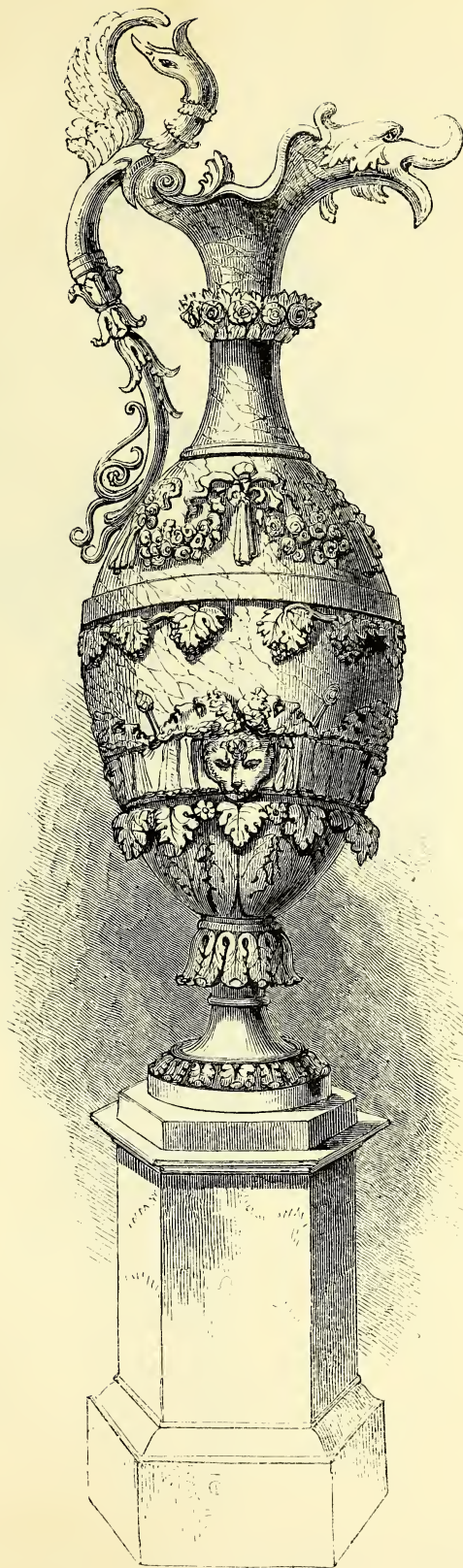



- 317 HALL, R., *Rotherhithe*—Designer and Carver.
Figure of Her Majesty, carved in English elm, designed for a ship's figure head.
- 318 SMITH, Captain, R. N.—Producer.
Design for a monument to Nelson.
- 319 WILKINSON, Sir GARDNER, 33 *York Street, Portman Square*—Producer.
Small table, from original designs, partly constructed from the cedars of Lebanon. This table is represented in the annexed cut.

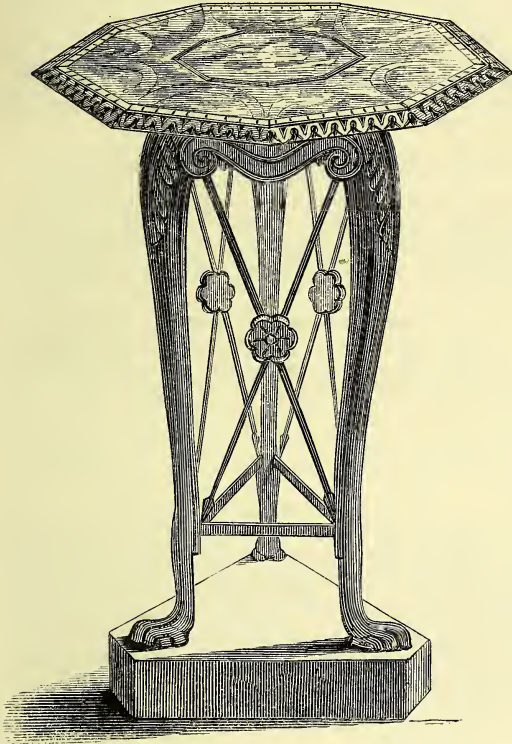

Sir G. Wilkinson's Table.

- 320 PEACHEY, JOHN, Jun., 10 *George Street, Hanover Square*—Proprietor.
Bronze bust of Sir Thomas Lawrence (by Samuel Parker, Esq.), made in London from a model produced at great cost, and afterwards destroyed.
- 321 INGRAM, JOHN W., 120 *Islington, Birmingham*—Inventor and Designer.
Cabinet, in the renaissance style of design, manufactured of wood and decorated by the enamel process, with electro-gilt metal mouldings.
Door of wood, enamelled and decorated with electro-gilt metal mouldings.
Pilasters, suitable for saloon, drawing-room, or boudoir decoration, on satin, unprepared, and painted in oil colour.
Specimens of imitation marbles, produced also by enamel painting.
- 322 GRAVES, DANIEL, *Lisson Grove Working Man's Institute*, late *King's Langley, Herts*—Designer and Proprietor.
Life of Our Saviour, illustrated with above 100 original ornamental designs, suitable for the goldsmith, ornamental decorator, paper-stainer, &c., executed with pen and ink, in a frame representing the nations of the world, at one view; with carved flowers and emblems of the four quarters at each corner of the frame, and Britannia in the centre, surrounded with suitable carved embellishments.

- 323 IBBETSON, Captain L. L. B., *Clifton House, Old Brompton*—Manufacturer and Inventor.
Electrotypes from the animal and vegetable kingdom. Ornamental castings in various metals, &c. (Also Main Avenue, No. 91.)
- 324 HULL, D., *Royal Polytechnic Institution, Regent Street*—Manufacturer.
Specimen of wire-work by hand, without tools, by the exhibitor, who is blind and self-taught.
- 325 M'HARDY, —, Gardener.
Models of gardens, &c.
- 326 WEST, ALICE—Producer.
Specimen of fresco painting.
- 327 RUSSELL, HENRY HEATHCOTE, C.E., 20 *George Street, Adelphi*—Inventor.
Model of the Royal Victoria Tower, proposed to be erected at Kingstown Harbour, Dublin, to commemorate Her Majesty's visit to Ireland, the funds to be appropriated to the Dublin Lying-in Hospital. Competition design for the Peel Testimonial, proposed to be erected in Peel Park, Salford.
- 328 ADSHEAD, Jos., 45 *George Street, Manchester*—Designer.
Illustrated plan of the township of Manchester in 24 sheets, being 400 square feet in size, corrected up to February, 1851: in which all public and private buildings, mechanical, chemical, print and dye works, canals, railways, &c., are respectively characterised by various shadings and colourings; executed upon a new plan, and upon a scale of measurement larger than has ever been attempted.
- 329 MILLS, ELIZA—Producer.
Specimen of fresco painting.
- 330 LITCHFIELD, JOHN, *Ridley, Hunts*—Producer.
Model of a cottage, composed of 2,000 pieces of willow wood dovetailed together without any glue or other cement, and carved with a penknife.
- 331 CHANCELLOR, FREDERIC, *Chelmsford*—Designer and Modeller.
Model of a covered homestall, suitable for a farm of from 300 to 500 acres, exhibiting an improved arrangement of the various buildings and yards required in such a farm. The advantages claimed by the exhibitor are—increased value of manure; saving effected in the fattening of stock, by protection from the inclemency of the weather; increased facilities afforded for supervision; greater security from depredation; and economy of space, capital, and labour, by the introduction of steam power, and the concentration of buildings.
- 332 BEECHAM—Producer.
Model of shop front.
- 333 PARTRIDGE, WILLIAM, 28 *Newman Street*—Designer and Producer.
Achievement of the armorial bearings of the late Sir Robert Peel, Bart.; enamelled on slate, as a funereal tablet for a church.
Magna Charta, illuminated with the armorial shields and names of the chief prelates and barons concerned; emblazoned on vellum.
- 334 BAXTER, JOHN, *Lewes and Ringmer, Sussex*—Designer.
Two models of improved farm-yard and buildings; one arranged with a view of securing all the advantages of collecting liquid and other manures from the stock, and of preparing them for the field; another, in a square form, of buildings on the same plan.
- 335 GRISSSELL, H. & M. D., *Regent's Canal Works*—Producers.
Guerin's steering apparatus.

336 PIKE, THOMAS JAMES, *Cheltenham*—Producer.

Specimen of glass, with the royal arms, emblazoned in ornamental shield, displayed with fruit and wreaths of flowers held by figures; with the dates of the Queen's coronation and marriage, and of the births of the members of the Royal Family, executed in ornamental writing on the back of the glass. The same, with the arms of H.R.H. Prince Albert, emblazoned and displayed with foliage in a similar style.

337 HAYWARD, R. J., *Danes Place, Kentish Town*—
Inventor.

New process of tinting steel plates for printing.

338 BELFAST GOVERNMENT SCHOOL OF DESIGN,
Ireland—Producer.

Designs for a damask table-cloth, by Hugh Blain; for a table-cloth, by John M'Kenzie; for the centre of damask table-cloth, by John Lawson; for an embroidered robe, by Matthew M'Kenzie; for an embroidered handkerchief, by Alexander Orr Agar, and Isaac Waugh; for an embroidered chemisette, by the latter; for a linen band, by Samuel M'Cloy, and James Ewart; for the top of a box, for cambrics, by the former; all pupils of the Belfast Government School of Design.

339 BARRITT, JAMES LITTLER, *173 Fleet Street*—
Designer and Manufacturer.

Model of a picture—"The Water Mill, Summer Evening."

340 WHAITE, H. C., *85 & 87 Bridge Street, Manchester*—
Inventor and Producer.

Flag, or banner, representing the "Royal Arms," painted on silk; with an elastic preparation, to prevent the cracking or breaking of the silk.

341 LEE, J. G., *Holborn*—Producer.
Imitation of marble, &c., on glass.342 COULTON, J. D.—Producer.
Designs for decorations.342A CLARKE, THOMAS CHATFIELD, *9 Percy Circus,
Lloyd Square*—Designer.
Design for a national sculpture gallery.343 THOMPSON, T. J.—Producer.
"God save the Queen," in wooden letters.343A HERDMAN, WM. GAWIN, *Everton, Liverpool*—
Inventor.

Diagram, showing an angular view of 106°, illustrative of a new system of perspective drawing. The improvement in this new method is in the relief from the restrictions of the systems hitherto in use, and which limited the art to the angle of 60° only, whereas by this system the angle is unlimited, and no distortion appears, whatever may be the angle.

Another diagram, drawn upon the same system, showing a front and lateral view, containing 120°.

344 BONNAR & CARFRAE, *Castle Street, Edinburgh*—
Designers and Executors.

Design, wrought in imitation of fresco painting, showing part of the walls of a drawing-room, &c.; design in the Pompeïan style, arranged to suit modern decoration; ornamental frieze and ceiling; design in imitation of inlaid wood, for the panels of walls, or woodwork of rooms.

Designs in imitation of inlaid marble, for panels of screens, &c., in the Watteau style, and suited for panels over doors.

345A SALTMARSH, G., *Southampton House, Kentish Town*—
Producer.

Specimen of penmanship.

346 NORTON, J., *Clayton West, Huddersfield*—Producer.
Model of manufactory.347 HURWITZ, B., *1 Brydges Street, Strand*—
Producer.

Emblematical decoration for drawing-room, and emblazoned glass tablet.

348 ZUCCANI, B., *40 and 41 Brick Lane, Spitalfields*—
Producer.

An aviary.

349 BURY, TALBOT, *50 Welbeck Street, Cavendish Square*.
Producer.

Specimen of distemper painting, executed in Miller's silica colours, representing a design for a palace of the arts; and a national gallery of painting and sculpture. The ground-floor is proposed to be appropriated to the sculpture of all countries and periods. The first floor to be one continuous picture-gallery, extending along the sides of two quadrangles, to exceed in dimension and length any other gallery in the world. The proposed site is that of the Great Exhibition.

350 HIS ROYAL HIGHNESS THE PRINCE ALBERT—
Proprietor.

Two slabs for tables, designed by L. Gruner, Esq., in the cinque-cento style, executed by Mr. Thomas Woodruff, at Bakewell, in Derbyshire stones, in imitation of the Florentine mosaic. One of these slabs is represented in the Plate.

351 HIS ROYAL HIGHNESS THE PRINCE ALBERT.

Candelabrum in the cinque-cento style, designed by L. Gruner, Esq., modelled by Ant. Trentanove, and executed in scagliola, in imitation of giallo antico, by L. Romoli.

352 DREW, THOMAS, *Troy Town, Rochester*—Producer.
Model of the Holy Temple.

353 HER MAJESTY THE QUEEN—Proprietor.

A cradle, carved in Turkey boxwood by W. G. Rogers, and designed by his son, symbolising the union of the Royal House of England with that of Saxe-Coburg and Gotha. One end exhibits in the centre the armorial bearings of Her Majesty the Queen, surrounded by masses of foliage, natural flowers and birds; on the rocker, beneath, is seen the head of "Nox," represented as a beautiful sleeping female, crowned with a garland of poppies, supported upon bats' wings, and surrounded by the seven planets. This cradle is represented in the accompanying Plate 121.

354 HILLIER, G. *Lambeth*—Producer.
Illuminated vellum.356 PEPPERCORN, —, Producer.
Statuettes.357 LAWSON, J.—Producer.
Design for a carpet.

358 MARSHALL, Lieut. R.—Producer.

Four specimens of Xylopyrography, or charred wood engraving.

359 SOUNES, WILLIAM, *49 Rupert Street,
Haymarket*—Producer.

Impressions from dies (cut in steel) for stamping metals, &c., intended for ornamental and other purposes.

360 FIELD, G.—Producer.

A specimen of wood carving in the middle of the last century, by Demontreuil.

361 SPIERS & SON, *102 & 103 High Street, Oxford*—
Manufacturers.

Models of buildings, in card-board, representing:—The Martyrs' Memorial, erected in Oxford, in 1841, by public subscription, to commemorate the death of Cramer, Ridley, and Latimer. The Cathedrals of Oxford, Ely, Lincoln, Bristol, and Salisbury. The Radcliffe Library;

Tom Tower, Christ Church; and the Churches of St. Mary Magdalen and St. Aldates, in Oxford. The Queen's marine residence, Osborne House, in the Isle of Wight; and the race-stand at Goodwood.

Medals of the Martyrs' Memorial, at Oxford, with the commemorative inscription on the reverse side, in silver, electro-gilt, bronze, and white metal.

Silver embossed work, consisting of card-cases, baskets, tablets, and vinaigrettes, ornamented with views of Oxford in relief.

Specimens of embossing, in colours, on writing-paper and envelopes, comprising the arms of several colleges in Oxford, and other official and private seals.

Charts of the eight-oared Oxford boat-races, from 1837 to 1850, printed in colours.

"A Memorial for Visitors to Oxford," being an illustrated card of business, containing views, maps, and general local information useful to the visitor and tourist, framed and mounted for use. See Class 17, No. 208.

362 SKINNER, —, *Sheffield*—Producer.

Fac-simile of chasing and engraving on metals, done by means of printing.

363 STEEDMAN & Co., *Charles Street, Hampstead Road*—Producers.

Specimens of japanning on slate, and altar decorations.

364 HORNER, G., *53 Rathbone Place*—Producer.

Painted decorations.

(The above two are placed on the South Wall.)

365 JOHNSON W., *10 Middlesex Place, New Road*.

An electrotype of Harman's shield of Achilles, from the original in the possession of Her Majesty.

366 HEPPLE, EDMUND, *Blackheddon House, Northumberland*—Proprietor.

A genealogical chart of the ancient families of Great Britain, deducing their descent, through a space of one thousand years, from Charlemagne and Egbert, and showing their consanguinity with all the sovereigns of Europe, who are traced back to Edward I. King of England, their common ancestor.

367 WHITE, JOHN WILLIAM, *34 Montague Square*—Inventor and Designer.

A duck's egg-shell, empty, and perforated with one hundred and thirty holes, about the size of a clove, after the manner of the Chinese ivory balls, and resembling fine light porcelain or Dresden china.

368 MAC LAINE, Lady, *13 Cumberland Street, Hyde Park*.

A remarkably small terrier, "Tiney," stuffed.

SCULPTURE COURT.

AREAS Q. TO S. 28, 29.

1 BROWN, ALFRED, *4 Red Cross Square*—Designer.
"David before Saul," a statue in plaster.

2 KIRK, J. R., A.R.H.A., *Jervis Street, Dublin*—Sculptor.

An original group, cast in plaster, "The creation of the dimple."

3 HUGHES, THOMAS, *28 Long Acre*—Designer.

Plaster figure of Eve convicted:—"The serpent me beguiled, and I did eat."—*Paradise Lost*.

4 FOLEY, J. H., A.R.A., *19 Osnaburgh Street, Regent's Park*—Sculptor.

The Wanderer.

5 DURANT, SUSAN, *14 Conduit Street West*—Designer and Sculptor.

Group in plaster, "Belisarius."

6 JENNINGS, B., *Hereford, and 17 Lower Eaton Street, Grosvenor Place, London*—Designer and Sculptor.
Marble bust of "The Madonna."

7 THOMAS, I. EVAN, *7 Lower Belgrave Place*—Sculptor.
Science (alto-relievo). The Spirit of Science unveiling Ignorance and Prejudice. The clouds of error recede before the light of truth.

8 LEGREW, JAMES, *1 St. Alban's Road, Kensington*—Designer and Proprietor.
Group, Cupid stung by a Bee, complains to Venus. Statue, Musidora.

9 CAREW, JOHN EDWARD, *40 Cambridge Street, Hyde Park*—Designer and Sculptor.
Alto-relievo—Baptism of Christ.

10 CAREW, JOHN EDWARD, *40 Cambridge Street, Hyde Park*—Designer and Sculptor.
Whittington listening to Bow bells—original model. This statue is represented in the following cut.



Carew's Statue of Whittington.

11 CAREW, JOHN EDWARD, *40 Cambridge Street, Hyde Park*—Designer and Sculptor.
Alto-relievo for a temple in Suffolk.

12 THOMAS, J.—Sculptor.
Nymph and sea-horse.

13 THEED, W., *12A Henrietta Street, Cavendish Square*—Designer and Sculptor.
Statue of Prometheus.

14 HOGAN, J., *14 Wentworth Place, Dublin*—Designer and Sculptor.
A drunken faun.

- 15 MARSHALL, W. CALDER, A.R.A., 47 *Ebury Street, Eaton Square*—Sculptor.
Sabrina; statue in marble.
Sabrina fair,
Listen where thou art sitting,
Under the grassy, cool, translucent wave,
In twisted braids of lilies knitting
The loose train of thy amber-dripping hair;
Listen for dear honor's sake
Goddess of the silver lake
Listen, and save.—*Milton's Comus.*
- 16 EARLE, T.—Sculptor.
Ophelia.
- 17 MILLER, FELIX MARTIN, 24 *Bloomfield Terrace, Pimlico*—Sculptor.
Group—Childhood.
- 18 FARRELL, T., 132 *Lower Gloucester Street, Dublin*—
Designer.
“Early sorrow,” sculptured in marble.
- 19 FOLEY, J. H., A.R.A., 19 *Osnaburgh Street, Regent's Park*—Designer and Sculptor.
Ino and the infant Bacchus.
- 20 SHARP, THOMAS, 27 *Burton Crescent*—Designer,
Modeller, and Sculptor.
Statue, in marble, of a Boy and Lizard.
- 21 EARLE, T.—Sculptor.
Pastorella.
- 22 LAWLOR, J., 30 *Wyndham Street, Bryanstone Square*—Designer and Executor.
A Bather,—statue in plaster.
- 23 CAMPBELL, T., 16 *Great Marlborough Street*—
Sculptor.
Portrait of a lady as a Muse.
- 24 BELL, JOHN, 15 *Douro Place, Victoria Road, Kensington*—Sculptor.
Sculpture, life size—Purity, or Una and the Lion.
- 25 KIRK, W. B., A.R.H.A., *Jervis Street, Dublin*—
Sculptor.
Original group in plaster, “Pastoral age.”
- 26 SHARP, THOMAS, 27 *Burton Crescent*—
Designer, Modeller, and Sculptor.
Model, in plaster, of “Christ's charge to Peter.”
- 27 PAPWORTH, EDGAR GEORGE, 17 *Newman Street, Oxford Street*—Sculptor.
“Cupid in disguise.”
- 28 ————
“Cupid and a swan.”
- 29 RITCHIE, JOHN, 62 *Princes Street, Edinburgh*—
Designer.
Statue, in marble, of a Poetess.
- 30 McDONNELL, —, *London*—Producer.
“Mother and child,” by a deaf and dumb artist.
- 31 FARMER, P., 4 *Hawley Terrace, Camden Town*—
Designer and Modeller.
Frieze, designed for a marble dining-room chimney-piece.
Frieze of scroll ornament, with figures of children, and goat's head in centre, composed in vine leaves.
- 32 SUMMERS, CHARLES, 86 *Warwick Street, Pimlico*—
Designer and Modeller.
Statue, in plaster, of Boy playing with shell.
- 33 FRANCIS, J., 56 *Albany Street, Regent's Park*—
Sculptor.
Statue of Her Majesty, in Carrara marble.
- 34 THORNYCROFT, THOMAS and MARY, 30 *Stanhope Street, Hampstead Road*—Sculptors.
Statues—The Prince of Wales and the Princess Royal as a young shepherd, and a gleaner. These statues are represented in the accompanying Plates 143, 144.
- 35 NELSON, GEORGE, 30 *Bidborough Street, Burton Crescent*—Sculptor.
Alto-relievo, cast in plaster, a figure of Victory, designed for a monument to the memory of the officers and men of the 50th Regiment, Queen's Own, who fell on the banks of the Sutlej, in India, during the campaigns of 1845-6.
- 36 STEPHENS, EDWARD B., 27 *Upper Belgrave Place, Pimlico*—Designer and Inventor.
“Eve offering to Adam the forbidden fruit.”—
* * * * * from the bough
She gave him of that fair enticing fruit
With liberal hand;
“The Expulsion from Paradise.”—
They, hand in hand, with wandering steps and slow,
Through Eden took their solitary way.
“The Curse.”—
* * * * * children thou shalt bring
In sorrow forth. * * * * *
In the sweat of thy face shalt thou eat bread,
Till thou return unto the ground.
“The Death of Abel.”—
Whereat he inly raged, and, as they talk'd,
Smote him into the midriff with a stone,
That beat out life; he fell.
- 37 ADAMS, G. G., 5A *Eccleston Street East, Pimlico*—
Sculptor.
Murder of the Innocents. The accompanying Plate, 146, represents this group.
- 38 MILLER, F. M., 24 *Bloomfield Terrace, Pimlico*—
Sculptor.
Bas-relief, brothers and sisters in “Comus.”
- 39 THRUPP, FREDERICK, 30 *Gloucester Place, New Road*—Designer and Sculptor.
Group in plaster of Paris, “The maid and the mischievous boy.”
- 40 JONES, J. E., 11 *Upper Charlotte Street, Fitzroy Square*—Designer and Producer.
Group of children and animals, portraits. The accompanying Plate represents this group.
- 41 MUNRO, ALEXANDER, 33 *Brewer Street, Golden Square*—Sculptor.
Francesca di Rimini and Paolo.
- 42 TAYLOR, F., *Romsey, Hampshire*—Designer
and Sculptor.
Life-sized figure of Our Saviour bearing the Cross.
- 43 GALLAGHER, JOHN, 10 *King Street, Regent Street*,
—Designer and Producer.
Design for a fountain in plaster, “Ariadne disconsolate at the loss of Theseus.”
- 44 SMITH, C. R., 37 *Gloucester Place, New Road*—
Sculptor.
Statue in mediæval costume: Lady Danberry.
- 45 JONES, J. E., 41 *Upper Charlotte Street, Fitzroy Square*—Designer and Producer.
Marble statuette, “the Favourite,” portrait.
- 46 KIRK, JOHN, *School of Design, Birmingham*—
Designer and Modeller.
Basso-relievo, in plaster, “Spiritless, afflicted, fallen,”
—*Milton's Paradise Lost.*
- 47 PHYSICK, EDWARD JAMES, 6 *Gloucester Place, New Road*—Designer and Modeller.
Pluto carrying off Proserpine.
By Pluto snatched away:
Love urged him to the deed.—*Ovid.*



143. HIS ROYAL HIGHNESS THE PRINCE OF WALES,
AS A YOUNG SHEPHERD.



144. HER ROYAL HIGHNESS THE PRINCESS ROYAL,
AS A GLEANER.

T. AND MARY THORNEYCROFT.



GROUP—THE MURDER OF THE INNOCENTS. G. G. ADAMS.



GROUP OF CHILDREN AND ANIMALS—PORTRAITS. J. E. JONES.

- 48 ADAMS, G. G., 5A *Eccleston Street East, Pimlico*—Sculptor.
Bas-relief, Combat of Centaurs and Lapithæ.
- 49 MILLER, FELIX MARTIN, 24 *Bloomfield Terrace, Pimlico*—Sculptor.
Bas-relief, Titania.
- 50 MILLER, FELIX MARTIN, 24 *Bloomfield Terrace, Pimlico*—Sculptor.
Ariel.
- 51 BEAUCLERC, CAPT. G., 23A *Grosvenor Street, West*—Producer.
Sleeping Nymph.
- 52 FARRELL, J., 123 *Lower Gloucester Street, Dublin*—Designer.
“The pet dove’s return,” a group in marble.
- 53 CAREW, JOHN EDWARD, 40 *Cambridge Street, Hyde Park*—Designer and Sculptor.
Alto-relievo original model—Descent from the Cross.
“Passus et sepultus est.”
- 54 BEHNES, W., 13 *Osnaburgh Street, Regent’s Park*—Sculptor.
Marble statue of a Startled Nymph.
- 55 _____
Boy, child, and goat.
- 56 THRUPP, FREDERICK, 30 *Gloucester Place, New Road*—Designer and Sculptor.
Marble statues — “Boys catching a butterfly.”
- 57 MANNING, SAMUEL, 3 *Union Place, Regent’s Park, and 61A York Terrace, Regent’s Park*—Sculptor.
Model of the statue of Prometheus, now being executed in marble.
- 58 THRUPP, FREDERICK, 30 *Gloucester Place, New Road*—Designer and Sculptor.
“Arethusa.”
- 59 THEED, WILLIAM, 12A *Henrietta Street, Cavendish Square*—Designer and Sculptor.
The Prodigal’s Return.
- 60 FRANKS, JOHN, 50 *Bazing Place, Waterloo Road*—Producer.
Portrait statue of John Flaxman, executed by the late M. L. Watson; executed in marble by Nelson.
- 61 M'DOWELL, P., R.A., 75A *Margaret Street, Cavendish Square*—Sculptor.
Early sorrow.
- 62 ADAMS, G. G., of Rome—Sculptor.
Contest between Minstrel and Nightingale.—Strada.
- 63 BEAUCLERC, CAPT. G., 23A *Grosvenor Street, West*—Producer.
Female figure on a couch.
- 64 GIBSON, JOHN, R.A., of Rome—Designer.
Basso-relievo in plaster, representing the Hours, and the Horses of the Sun.
- 65 THORNYCROFT, THOMAS and MARY, 39 *Stanhope Street, Hampstead Road*—Sculptors.
Basso-relievo—Group of three children.
- 66 MILLER, FELIX MARTIN, 24 *Bloomfield Terrace, Pimlico*—Sculptor.
Bas-relief—Spirit of Calm.
- 67 MILLER, FELIX MARTIN, 24 *Bloomfield Terrace, Pimlico*—Sculptor.
The attendant spirit in Comus descending on a glancing star, in bas-relief.
- 68 MILLER, FELIX MARTIN, 24 *Bloomfield Terrace, Pimlico*—Sculptor.
Bas-relief, Lycidas.
- 69 PHYSICK, EDWARD GUSTAVUS, 6 *Gloucester Place, New Road*—Sculptor.
Head of the dying Saviour, in marble.
- 70 FOLEY, J. H., A.R.A., *Osnaburgh Street, Regent’s Park*—Designer and Sculptor.
“Innocence.”
- 71 BELL, JOHN, 15 *Douro Place, Victoria Road, Kensington*—Inventor and Producer.
Dorothea, from “Don Quixote.”
- 72 BELL, JOHN, 15 *Douro Place, Victoria Road, Kensington*—Inventor and Producer.
Sculpture—“The Babes in the Wood,” from the English ballad. This group is represented in the engraving.



Bell's Babes in the Wood.

- 73 MANNING, SAMUEL, 3 *Union Place, Regent's Park,*
and 61A *York Terrace, Regent's Park*—Sculptor.
Model of the statue of John Wesley, M.A., executed
in marble by Mr. Manning, and presented to the Wes-
leyan Theological Institution, Richmond, Surrey, 1849,
by Thomas Farmer, Esq.
- 74 WESTMACOTT, JAMES SHERWOOD, 1 *St. John's Place,*
Lisson Grove—Designer.
Model of Saher de Quincy, Earl of Winchester, A.D.
1215, to be executed in bronze, for the interior of the
new House of Lords. The chain armour is carved by the
hand, and not stamped. This model is represented in
the accompanying Plate 149.
- 75 DURHAM, JOSEPH, 50 *Cambridge Street, Hyde Park*
—Sculptor.
L'Allegro.
- 76 DURHAM, JOSEPH, 26 *Alfred Place, Bedford Square*
—Sculptor.
Il Pensive.
- 77 BEHNES, W., 13 *Osnaburgh Street, Regent's Park*—
Sculptor.
Statuette of Lady Godiva.
- 78 DURANT, SUSAN, 14 *Conduit Street West, Hyde Park*
—Producer.
Statue of a girl: a study from nature.
- 79 THEED, WILLIAM, 12A *Henrietta Street, Cavendish*
Square—Designer and Sculptor.
Narcissus.
- 80 EARL OF YARBOROUGH, 17 *Arlington Street,*
Piccadilly—Proprietor.
A statue in marble.—A Greek hunter and dog, by John
Gibson, R.A., of Rome. This statue is represented in the
accompanying Plate 12.
- 81 JENNINGS, B., *Hereford, and 17 Lower Eaton Street,*
Grosvenor Place, London—Designer and Sculptor.
Marble statue of Cupid.
- 82 EARLE, T.—Sculptor.
Nature's mirror.
- 83 SMITH, C. R., 37 *Gloster Place, New Road*—
Sculptor.
Statue of Michael Angelo, in mediæval costume.
- 84 JONES, J. E., 41 *Upper Charlotte Street, Fitzroy*
Square—Designer and Producer.
Medallion. Subject—Mother and child, portraits.
- 85 THE ART UNION OF LONDON CORPORATION,
444 *West Strand*—Producer.
Competition statuettes:—Satan punished in the mo-
ment of imagined triumph. Solitude. The Huntsman.
Lycidas. Undine. "On Earth Peace." The Water
Lily. Spring. The Young Mother. Ephialtes chained.
Echo. Nydia. Girl and Butterfly. Hesione. A Nymph.
Alfred. Industry. Britannia. Cupid. Orpheus. Ari-
adne. Musidora. Psyche disguised. Murder of the
Innocents.
- 86 WYON, E. W., 48 *Chenies Mews, Bedford Square*—
Sculptor.
Tazza, modelled from a Greek design for the Art
Union of London.





12.

GREEK HUNTER, BY JOHN GIBSON. LORD YARBOROUGH.

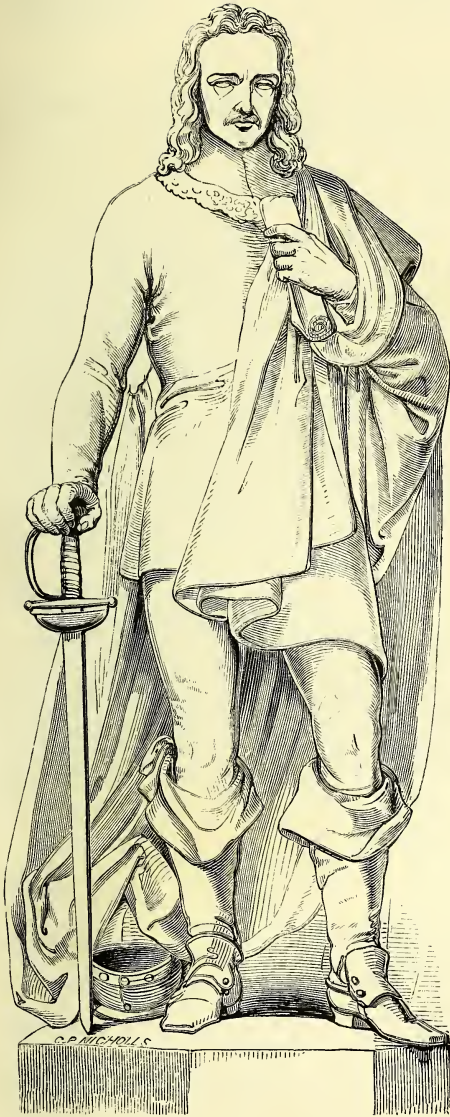

148. MODEL FOR A STATUE OF HAMPDEN.
J. H. FOLEY, A.R.A.

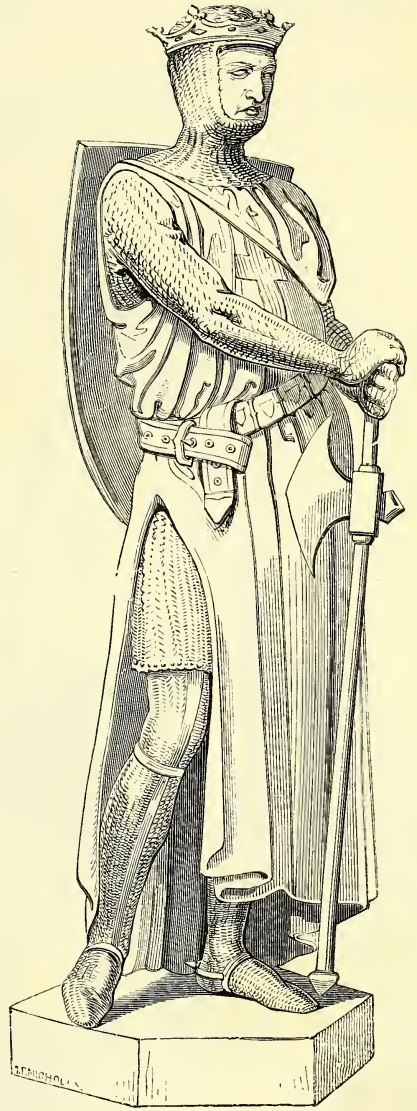

149. MODEL FOR A STATUE OF SAHER DE QUINCEY,
EARL OF WINCHESTER, A.D. 1215. J. S. WESTMACOTT.

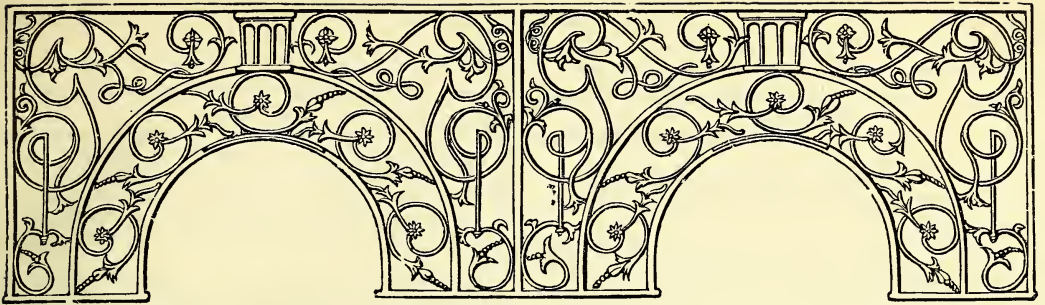

MISCELLANEOUS OBJECTS OF INTEREST PLACED IN THE MAIN AVENUES
OF THE BUILDING AND NOT CLASSIFIED.

HER MAJESTY THE QUEEN—Proprietor.

In Indian Department: presented to Her Majesty by the Nawab Nazim, of Bengal. A splendid reception seat, with canopy of purple velvet, embroidered in gold, supported on silver pillars, with two "moarchals," or emblems of dignity, used by the princes of India upon state occasions, made of pure gold, and containing feathers of the birds of paradise. A state palanquin of ivory, with canopy of gold-embroidered cloth. A purdah, or canopy, used only by persons of the highest rank. A nalkee, a palanquin of ivory, used only when the sun is below the horizon. A howdah, or palanquin, with trappings, to be borne on the back of an elephant. State harness and ornaments for horses and camels.

ADAMS, G. G., *Rome*—Sculptor.

Model, life size: Figure, with torch, &c.

ARCHER, J. W., 46 *Clarendon Street, Somers Town*—
Designer.

Monumental tablet in brass, to the memory of the officers of Lord Hardinge's staff, who fell in the battles of the Sutlej; produced by direction of Lord Hardinge, and intended to be sent to India. The ornaments composed from Oriental poems. Exhibiting a new method of relief, and a new colouring material.

BAILEY, E. H., R.A., F.R.S., 17 *Newman Street, Oxford Street*—Sculptor.

A Nymph preparing for the bath.
A Youth resting after the chase.

BEHNES, WILLIAM, 13 *Osnaburgh Street, Regent's Park*—
Sculptor.

Colossal statue of Sir William Follett.

BELL, JOHN, 15 *Douro Street, Victoria Road, Kensington*.
—Producer.

Shakspeare: a statue in plaster. The likeness from the bust over the poet's tomb at Stratford-on-Avon. This statue is represented in the annexed cut (next column).

Model for statue of Lord Falkland, executed in marble for the new palace, Westminster.

BRINE BROTHERS, & T. SHARPE—Producers.

Ornamental chimney-piece.

BRUCCIANI, D., 5 *Little Russell Street*—Manufacturer.

Plaster cast of "Apollo Belvedere," from the original; to imitate marble.

CATLIN, GEORGE, 6 *Waterloo Place*—Designer
and Proprietor.

Model of the Falls of Niagara, in composition, designed from an actual and minute survey made by the exhibitor



Bell's Statue of Shakspeare.

in 1827. This model strictly illustrates nearly a mile square around the Falls, showing both cataracts, with every house, bridge, tree, rock, factory, island, and other characteristic feature. The gradual wearing down of the bed of rock over which the vast volume of water pours is clearly represented.

CHAMPERNOWNE, HENRY, Dartington House, Totnes—Proprietor.

Polished columns of madrepora marble, with Caen stone capitals.

Specimen of the marble, with one side polished, showing the constituent pebbles and madreporas imbedded in calcareous clay.

The quarries produce blocks up to twelve feet by four feet on the bed, and two feet in thickness; and others varying in length and thickness. This marble is adapted for ecclesiastical, architectural, and domestic decorations.

CUNDY, S., Belgrave Wharf, Pimlico—Producer.

A restoration of a portion of the monument of Philippa of Hainault, queen of Edward III., in Westminster Abbey, executed in English alabaster from the drawings and under the direction of Mr. G. G. Scott, and from the remains that have been found embedded in an adjoining tomb.

This monument was executed in the year 1370, by one "Hawkin Liege, from France," at a cost of 133*l.* 6*s.* 8*d.*, or, when converted into our present currency, about 2,000*l.* The character of the work throughout shows the hand of a foreign artist. The niches were occupied by thirty-two statuettes, representing different branches of the family, of which a nearly accurate list is preserved. The statuettes seen in the portion exhibited (which represents the head of the altar tomb) are those of Edward the Black Prince, Lewis Emperor of Germany, King Edward III., John King of France, and William Earl of Hainault.

Besides the effigy of the queen and the statuettes referred to, there were representations of angels in the tabernacle work and other parts; so that the whole monument contained not less than 80 figures, which, from their remains, appear to have been admirable works of art. The monument is now in a state of great dilapidation. The statuettes and angels in the restoration, were executed by Mr. John Philip.

DAVIS, EDWARD, 17 Russell Place, Fitzroy Square—Artist.

Bronze statue of his Grace the Duke of Rutland, for the market-place at Leicester.

Group in marble of Venus and Cupid.

Alto-relievo in marble, the Virgin and Child.

DIGHTON, THOMAS DIBDEN, 25 College Street, Westminster—Producer.

Model of the interior of Her Majesty's Theatre, to a scale of three-quarters of an inch to a foot.

General dimensions of the theatre: from the proscenium to the back of boxes, at front of the house, 98 feet; diameter across the house to back of boxes, 72 feet; height from the pit floor to ceiling, 55 feet.

Sitting room: in boxes, 870; pit, 500; gallery and stalls, 800; slips, 32; pit stalls, 222. Total, 2,424. The house will hold 3,000.

[The interior of this theatre was entirely renovated in the year 1845, in the style of the Italian arabesques of the fifteenth century. The figurative paintings in front of the boxes were committed to the care of Mr. J. Powell, artist, and his assistants; the arabesque ornaments to Mr. Sang; the whole being executed from the designs and under the superintendence of Mr. John Johnson, F.S.A., Architect, 9 John Street, Adelphi.]

EARLE, THOMAS, 1 Vincent Street, Ovington Square—Designer.

Model—Jacob and Rachel: "And Jacob kissed Rachel, and lifted up his voice, and wept."—*Genesis* xxix. 11.

ELKINGTON & Co., Birmingham—Manufacturers.

Colossal head of a horse, modelled by the Baron Marchetti.—Electro-deposit.

Bust of Prince Albert, the Duke of Wellington, and the late Sir R. Peel, Bart.

ELDON, JOHN, EARL OF, 1 Hamilton Place, Piccadilly—Proprietor.

"The Eldon and Stowell group," being a colossal work in marble, representing two celebrated brothers—John, first Earl of Eldon, for nearly 25 years Lord High Chancellor of Great Britain, and William Baron Stowell, for 29 years Judge of the High Court of Admiralty of England. This group is represented in the accompanying Plate.

The work was designed and modelled by the late Musgrave Leiothwaite Watson, Esq., and has been executed in marble and completed by George Nelson, Esq. Each statue is wrought out of a single block of marble, and the whole weighs 20 tons.

ENGEL, JOSEPH, 27 Berners Street, Oxford Street—Producer.

Group in marble (the property of His Royal Highness the Prince Albert). An episode in the history of the war between the Amazons and the Argonauts, viz.: A sister in arms comes to the rescue of an Amazon fighting with an Argonaut, who lies prostrate at their feet. On the point of inflicting a deadly blow, she is restrained by her wounded companion, who, struck with sympathy for his fallen state, drops her resentment and yields to pity; love at length becoming the dominant passion of her soul. This group is represented in the accompanying Plate 142.

FOLEY, J. H., A.R.A., 19 Osnaburgh Street, Regent's Park—Designer and Producer.

A youth at a stream. The following engraving represents this statue.



Foley's "Youth at a Stream."

Model for the statue of Hampden, executed in marble for the New Palace of Westminster. This statue is represented in the accompanying Plate 148.

The Mother.



120.

THE ELDON AND STOWELL GROUP. EXECUTED IN MARBLE BY G. NELSON.
EXHIBITED BY THE EARL OF ELDON.

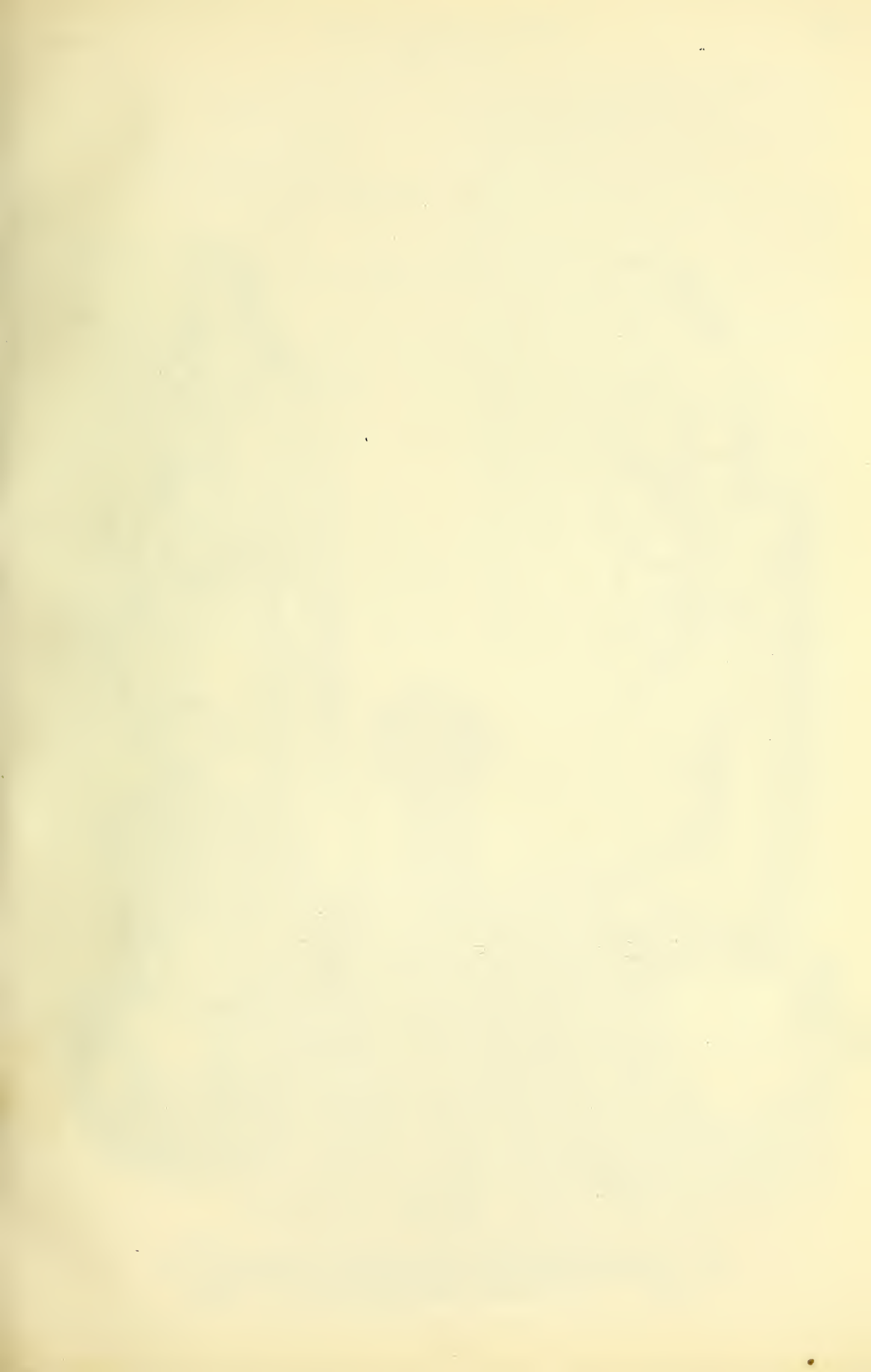



150. STATUE OF ROSAMONDA. J. THOMAS.



151. STATUE OF DANTE'S BEATRICE. J. HANCOCK.

FORREST, ANDREW H., 33 *Castle Street, Leicester Square*—
Designer.

Statue in plaster of Paris—"The Forsaken."

Ye mustering thunders from above,
Your willing victim see;
But spare and pardon my false love,
His wrangs to heaven and me,
Vide *Burns' Ballad of "Lord Gregory."*

GOULD, —, Producer.

Monumental brass.

HANCOCK, JOHN, 101 *Stanhope Street, Regent's Park*—
Sculptor.

Dante's *Beatrice*—

Last All Saints' holiday even now gone by,
I met a gathering of damozels;
She that came first, as one doth who excels,
Had Love with her bearing her company;
A flame burned forward through her stedfast eye
Most like the spirit in living fire that dwells:
Gazing with that meek courage which prevails
O'er doubt. I saw an angel visibly,
As she passed on.—*Vita Nuova.*

This statue is represented in the Plate 151.

HOLLINS, PETER, *Birmingham*—Designer and
Modeller.

A colossal group—The Murder of the Innocents.

HOPE, A. J. B. Esq., M.P., 1 *Connaught Place*—
Proprietor.

The largest known pearl, weighing 3 ozs., or 1,800
grains; length 2 ins., circumference $4\frac{1}{2}$ ins.

Hungarian opal, $1\frac{1}{3}$ in. long by $1\frac{5}{16}$ in. broad.

Handle of Murat's sword. The hilt of a single beryl,
or aquamarine.

Very scarce variety of amethyst, from Transylvania.

Two emeralds, engraved and arranged as a vinaigrette.
Their joint weight 193 grains.

"Le Saphir Merveilleux." Sapphire, of an amethystine
colour by candlelight.

Crystal containing a drop of water.

Gold-coloured cat's eye.

Asterias sapphire, showing a six-rayed star. Weight
234 grains.

Sapphire, amethyst, topaz, brown diamond, emerald,
and two jacynts.

Largest known cat's eye, taken from the king of Kandy
when conquered.

Mexican opal, engraved with the face of the Sun.

Engraved jacynth. Antique.

Engraved jacynth ring of Popes Gregory XIII. and
Pius VII.

Turquoise, with Persian writing.

Carbuncle or garnet.

Diamond cut against the grain.

Engraved cat's eye.

Emerald in the matrix.

Beryl, or aquamarine.

Engraved oriental ruby, cinque-cento.

Enamelled garnet.

Two-coloured topaz.

Irish beryl, or aquamarine.

Beryl, or aquamarine.

Engraved dichroite. Antique.

Pearls.

Mina Nova.

Asterias ruby.

Jacynth.

Opals.

Emerald.

White topaz.

Sun-stones.

Green diamond.

Opals.

Turquoise.

Tourmaline.

Turquoise in the matrix. Amethyst in the matrix.

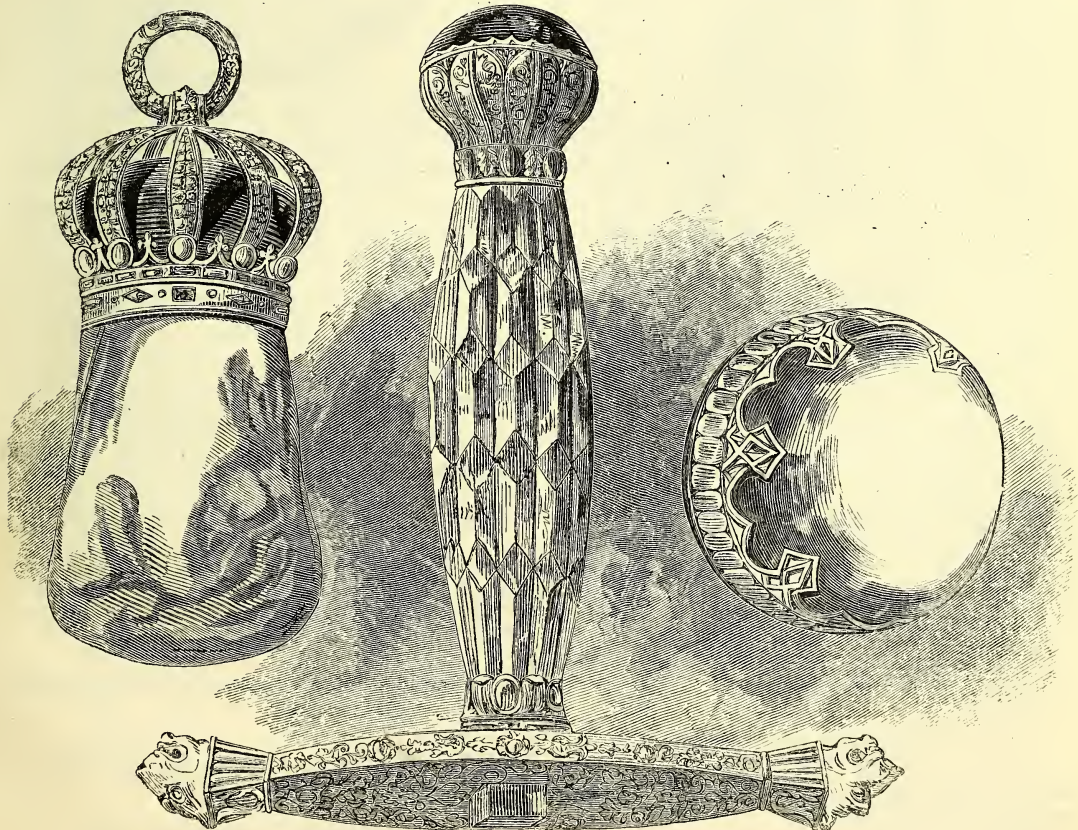

Mr. Hope's Great Pearl, Cat's Eye, and Handle of Murat's Sword.

LOUGH, JOHN GRAHAM, 42 Harewood Square—
Designer and Sculptor.

Fighting horses. Jealousy of Oberon.
The Fairy Queen (Titania) from Shakspeare's "Midsummer Night's Dream," act iv., scene 1. This statue is represented in the annexed illustration.



Lough's "Titania."

Ariel.

Where the bee sucks there lurk I * * * *
Under the blossom that hangs on the bough.
Tempest, act v., sc. 1.

This statue is represented in the illustration, next column.

Puck, from Shakspeare. This statue is represented in the engraving, p. 851.

"The archangel Michael, having subdued Satan,"—Milton. The accompanying Plate, 51, represents this statue.

The Mourners.

MAC DOWELL, PATRICK, R.A., 75A Margaret Street, Cavendish Square—Sculptor.

Colossal group of Virginius and daughter, in marble.
Cupid, in marble. Eve, a model.
A girl praying.

MARSHALL, W. CALDER, A.R.A., 47 Ebury Street, Eaton Square—Sculptor.

Model for a statue in bronze of Dr. Jenner, the introducer of vaccination, proposed to be erected as a tribute to his merits by all nations.

Zephyr and Aurora.

The Dancing-girl reposing.



Lough's "Ariel."

MATHER, ALEXANDER ANDREW, 30 Great Marlborough Street—Designer and Sculptor.

An elaborate carved Gothic monument and Purbeck marble tablet, with inscription cut in the early English character, highly emblazoned.

MILLER, F. M., 24 Bloomfield Terrace, Pimlico—Sculptor.

The Orphans.

MILNES, T., Judd Place East, Euston Square—Designer and Sculptor.

Model of a colossal statue of the Duke of Wellington: erected in the Tower of London.

PANORMO, C., A.R.H.A., Queen Square West, Dublin—Sculptor.

Clay model, an original design, taken from the liberation of Caractacus—history of England.—"Why envy me an humble cottage in Britain, whilst you have such vast magnificence at home?"

PEYMAN, HENRY PRINCE, Abingdon, Berks—Sculptor.
Font, executed in marble.

PHYSICK, EDWARD JAMES, 6 Gloucester Place, New Road—Designer and Modeller.

Adam.

Straight toward Heaven my wondering eyes I turn'd,
And gaz'd awhile the ample sky, till rais'd
By quick instinctive motion up I sprung.—*Par. Lost, book 8.*

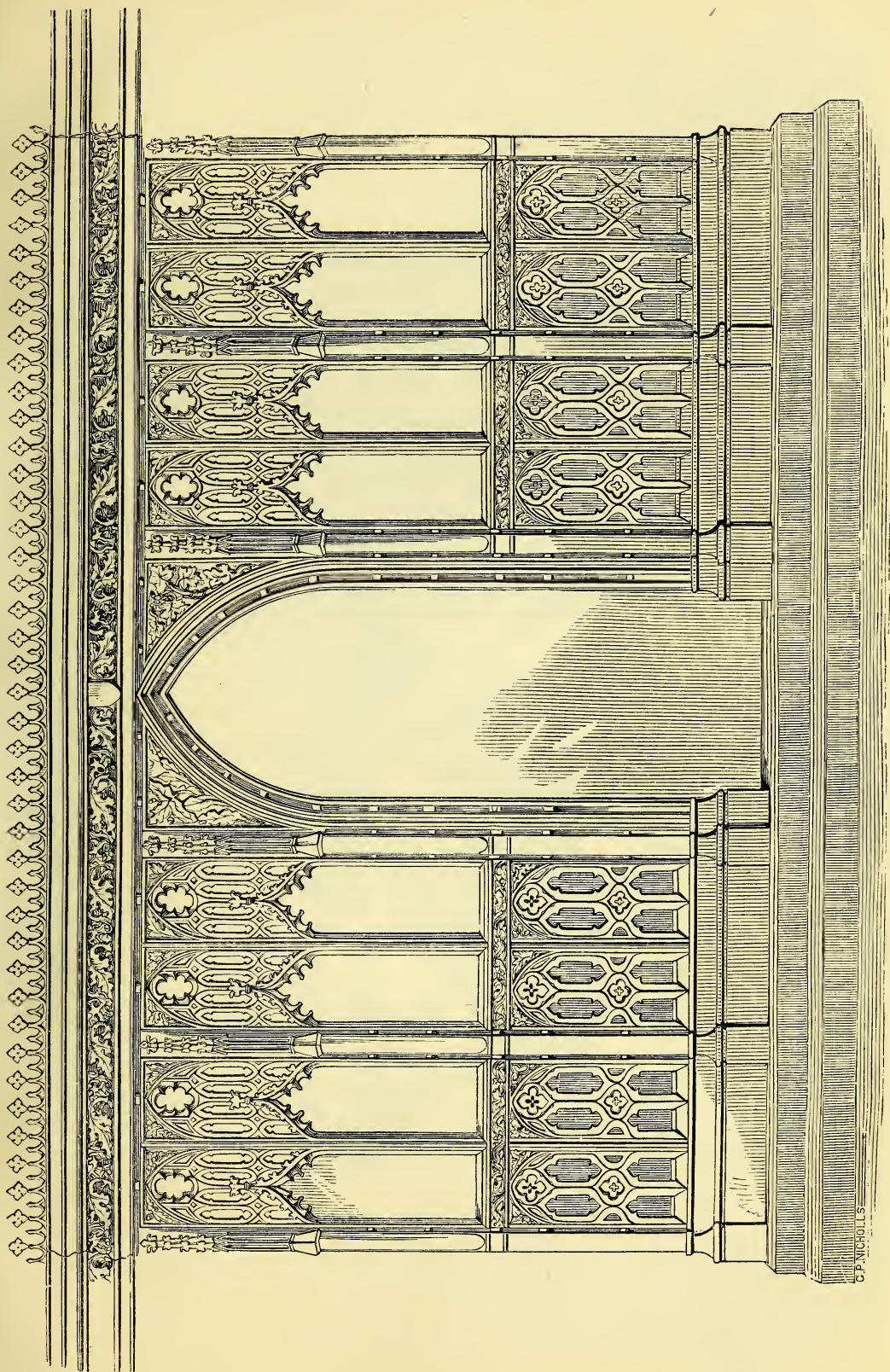

C.P. NICHOLLS

AN ALTAR SCREEN. EXHIBITED AS A SPECIMEN OF MACHINE CARVING IN WOOD BY JORDAN'S PATENT MECHANISM.

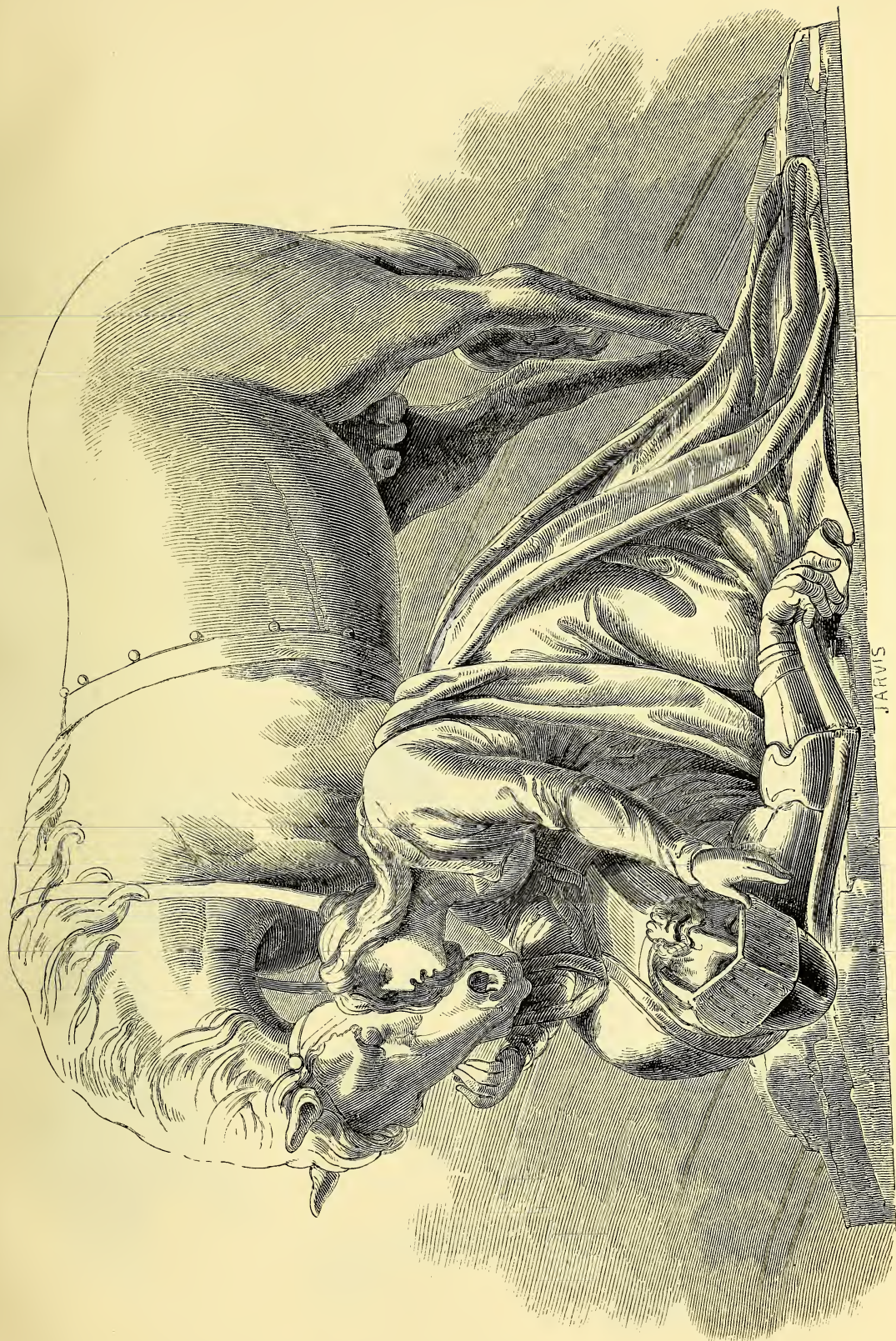

JARVIS

THE MOURNERS. MR. J. G. LOUGH.



THE ARCHANGEL MICHAEL, HAVING SUBDUED SATAN. J. LOUGH.

MODEL OF THE DOCKS AND COMMERCIAL PORTION OF THE TOWN OF LIVERPOOL.

DESIGNED BY JOHN GRANTHAM, C.E.

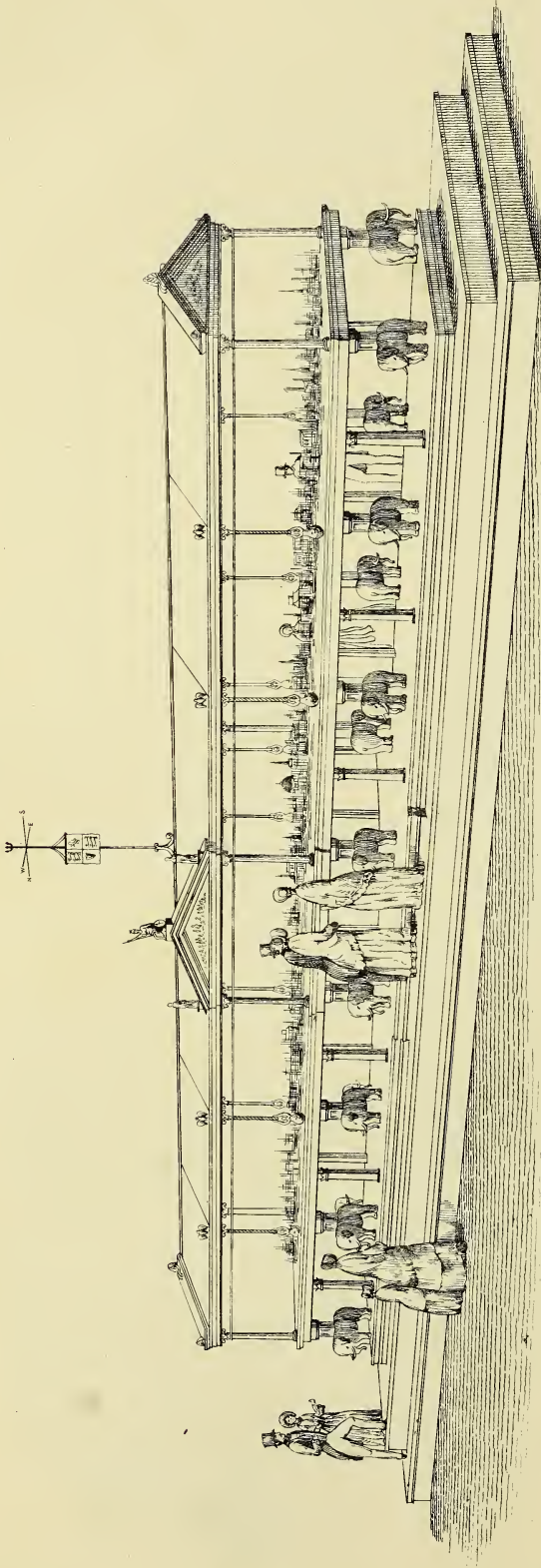

References.

- A. St. George's Hall & Railway Station.
- B. St. John's Market.
- C. St. Peter's Church & Blue Coat Hospital.
- D. St. George's Church.
- E. Custom House & Exchange Buildings.
- F. Town Hall & Exchange Buildings.
- G. Railway Station, Tithmarsh Street.
- H. D^o Waterloo Road.
- I. Borough Jail.

Scale of Model, 8 Feet = 1 Mile.

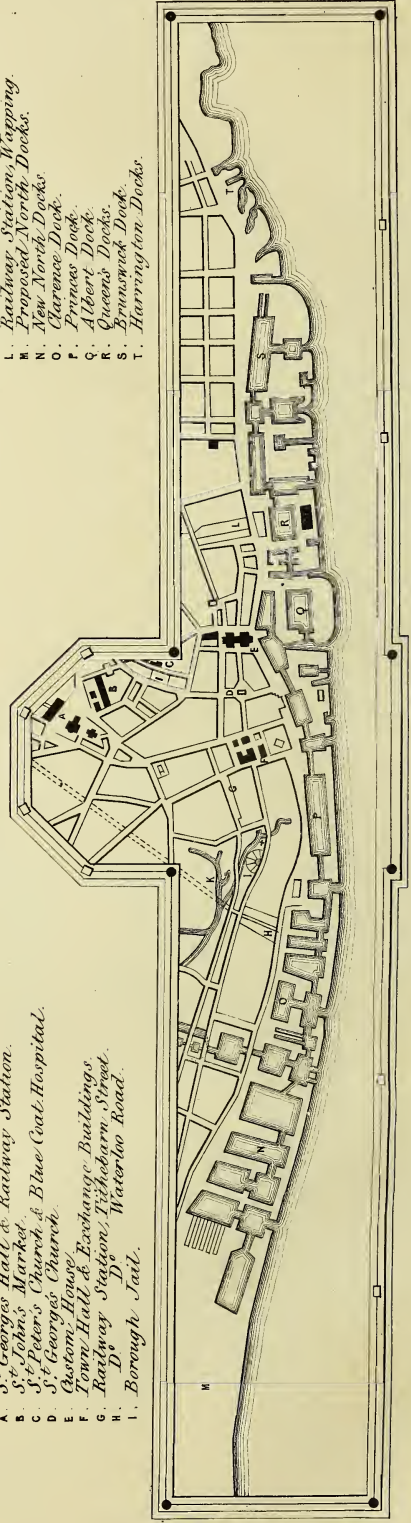

- K. Leeds & Liverpool Canal.
- L. Railway Station, Whipping.
- M. Proposed North Docks.
- N. New North Docks.
- O. Clarence Dock.
- P. Francis Dock.
- Q. Albert Dock.
- R. Queens Dock.
- S. Bramwich Dock.
- T. Harrington Docks.



Lough's "Puck."

SALTER, STEPHEN, *Elvar Cottage, Hammersmith*
—Modeller.

Model of St. Nicholas' church, now erecting at Ham-
burg, carved by hand in crayon paper made into cardboard.
This material is said to be superior to plaster for strength
and portability.

Model of Dinting Vale Viaduct on the Sheffield and
Manchester railway: also carved by hand in crayon paper
cardboard, and showing all the details of the timber,
bracing, &c. The viaduct is constructed for the purpose
of carrying the railway over a wide and deep valley near
Glossop, in Derbyshire.

[The five large arches of the Dinting Vale Viaduct are
each 125 feet span and 25 feet rise; the total length of the
viaduct is 484 yards, and its height above brook is 125 feet.
It was erected in 1843-4, and cost 35,250*l*. The mode of
constructing arches with laminated deals suggested itself
to Mr. Green, of Newcastle-upon-Tyne, in 1827-8, and the
principle has since been extensively employed both for
bridges and roofs.—S. C.]

Model of a bridge erected across the river Ouse, at Selby,
in Yorkshire, in the line of the Hull and Selby railway;
also carved by hand, in crayon paper cardboard, and showing
all the details of the machinery, ironwork, &c. The
bridge is of cast iron, consisting of six ribs in width; the
opening arch is formed of two leaves worked upon a centre
carriage, with tail-pieces acting as counter-balances for
assisting the opening and shutting: this is accomplished
by an iron segment of 9 feet radius, firmly fixed upon the
main shaft, worked by a system of wheels so adapted that
one man can raise or lower either leaf of the bridge in 50
or 60 seconds.

IBBETSON, CAPT., LL.B., *Clifton House, Brompton*—
Producer.

Trigonometrical model of the Undercliff, Isle of Wight,
from a trigonometrical survey, the vertical heights being
on the same scale as the base.

JORDAN, —, Producer.

Specimens of machine carving:—Altar screen, designed
by W. Harris; chairs; carved trophy of birds; foliage;
statuettes, &c. This screen is represented in the
Plate 99.

LEGREW, J., *1 St. Alban's Road, Kensington*—
Producer.

Samson bursting his bonds.
Group: Milton and his daughters.

LEIFCHILD, HENRY STORMOUTH, *23 Newman Street*—
Designer and Sculptor.

Group in plaster, "Rizpah watching over the dead
bodies of her sons."—2 *Samuel* xxi. 10.

LIVERPOOL LOCAL COMMITTEE, *Town Hall*,
Liverpool—Proprietors.

The Port of Liverpool—a scene of British industry.
This model, which represents a sea wall of five miles,
at a scale of eight feet to the mile, was made for the
Great Industrial Exhibition of all Nations, 1851. It em-
braces the whole of the docks, about 300 acres; and
about one-third of the town—the commercial portion.
The buildings are all modelled with great accuracy and
care. It includes the three great stations of the London
and North Western Railway, and one of the Lancashire
and Yorkshire Railway, the Town Hall, Custom-house,
Sailor's Home, several churches, and St. George's Hall,
said to be the finest Grecian building in England. The
water and docks are formed of pale green glass, sil-
vered. The ships are neatly modelled and completely
rigged. The docks and river contain the usual quantity
of vessels, together with about sixty steamers and small
craft. The streets and quays are covered with carts,
cars, omnibuses, men, and merchandise.

The model is contained in a beautiful glass case, sur-
mounted by statuettes, representing two of the local
monuments, Canning and Huskisson, with Britannia taken
from the figure on the dome of the Town Hall. The case
is supported by fourteen elephants and twenty columns
standing on a plinth. It is accompanied by an index
map, on which is the following table:—

Rise and Progress of Liverpool.

	Under Queen Elizabeth, 1570.	Under Queen Anne, 1710.	Under Queen Victoria, 1850.
Population	800	8,168	400,000
Tonnage . . . Tons	268	12,636	3,536,337
Number of Vessels . . .	15	334	20,457
Dock Dues . . . £	..	600	211,743
Town Dues . . . £	20	379	91,000
Amount of Customs £	272	70,000	3,366,284
Income of the Cor- porations. } £	20	1,115	139,152

The model was projected by John Grantham, C.E.,
and superintended by a committee. The accompanying
lithograph represents this model.

LODDIGES, C. & SONS, *Hackney*—Producers.

A collection of palms and other tropical plants.

M'CARTHY, HAMILTON, *17 Albert Terrace, Knightsbridge*
—Sculptor, Designer, and Modeller.

Group of deer-stalking. Group. Colossal head of a
horse.

POTTER, T.—Producer.

Spandril from Hereford Cathedral, designed by N. J. Cottingham; carved by Boulton and Swales. Statuettes,

&c. Brass lectern for Hereford Cathedral, designed by Cottingham; executed by the exhibitor. The following illustration represents the spandril.

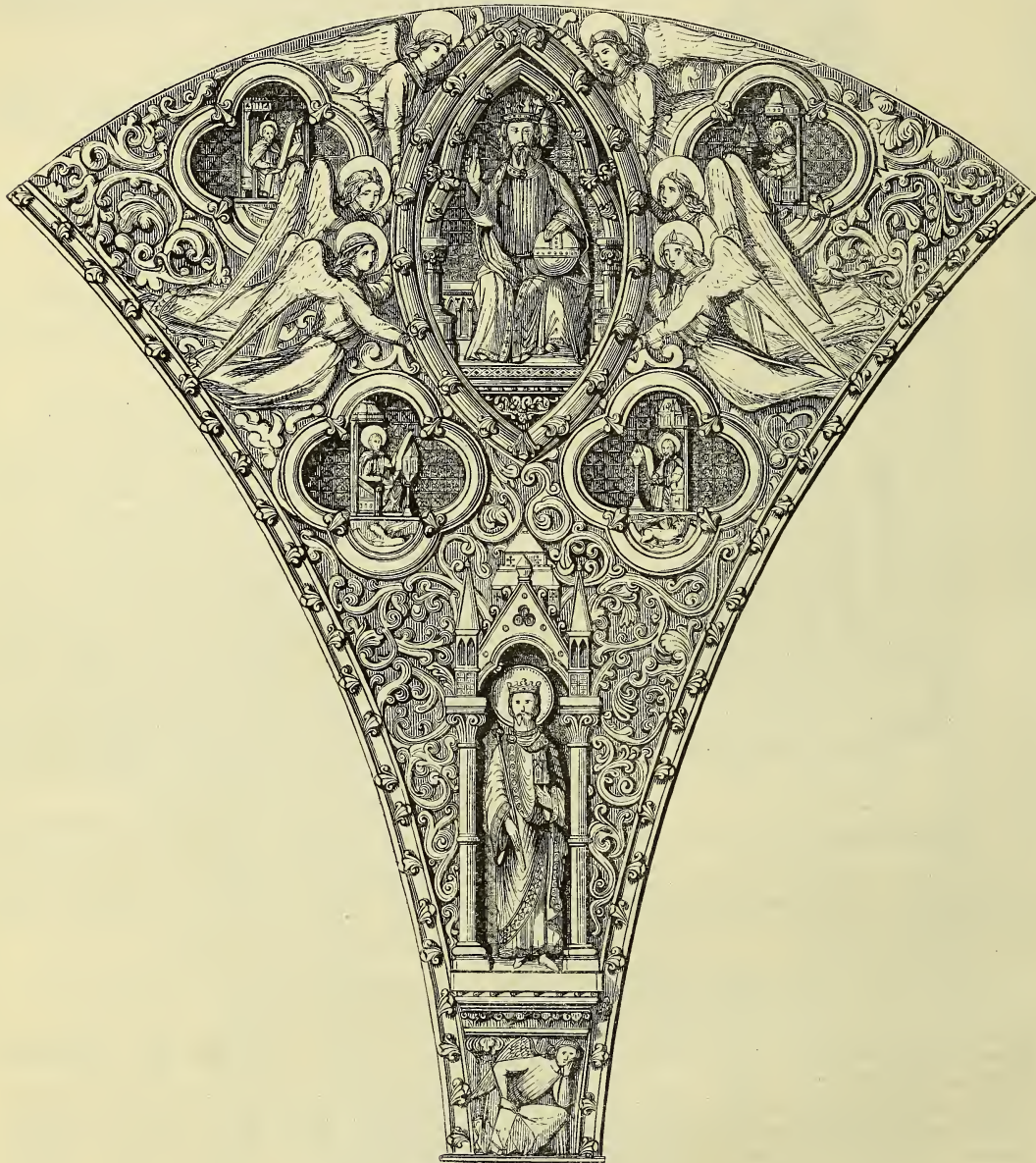

Potter's Hereford Cathedral Spandril.

PURDY, CHARLES WILLIAM, *Warwick Street, Pimlico*—
Designer and Executor.

Gothic monument, of the decorated style; period, fourteenth century; the inscription tablet represents a roll of parchment, supported by two angels, &c. At the bottom is an angel with a shield, supporting the whole; there is a canopy over the top, richly carved.

ROSS, HON. HARRIET M., *Bladensburg, Rosstrevor, Ireland*—Designer and Sculptor.

Monumental Irish cross, of Caen stone, illustrating, in bas-relief, portions of Holy Writ: Moses raising the serpent, Abel's sacrifice, Noah entering the ark, the translation of Elijah, and the heads of the prophets Isaiah, Jeremiah, Ezekiel, and Daniel.

The New Testament subjects are the Crucifixion, the Return of the Prodigal Son, the Good Shepherd, the Resurrection, and the heads of St. Peter, St. John, St. James, and St. Paul.

SEELEY, JOHN, *Keppel Row, New Road*—Manufacturer.

Fountain, suitable for the market-place of a provincial town; artificial stone, tested for twenty years. Registered design by J. W. Papworth, architect, 14 Great Marlborough Street. The accompanying Plate 82, represents this fountain.

SIBSON, HENRY, *25 Douro Cottages, St. John's Wood*—
Designer and Proprietor.

A recumbent full-sized figure in plaster of Paris—
"The dying shipwrecked Sea-boy."

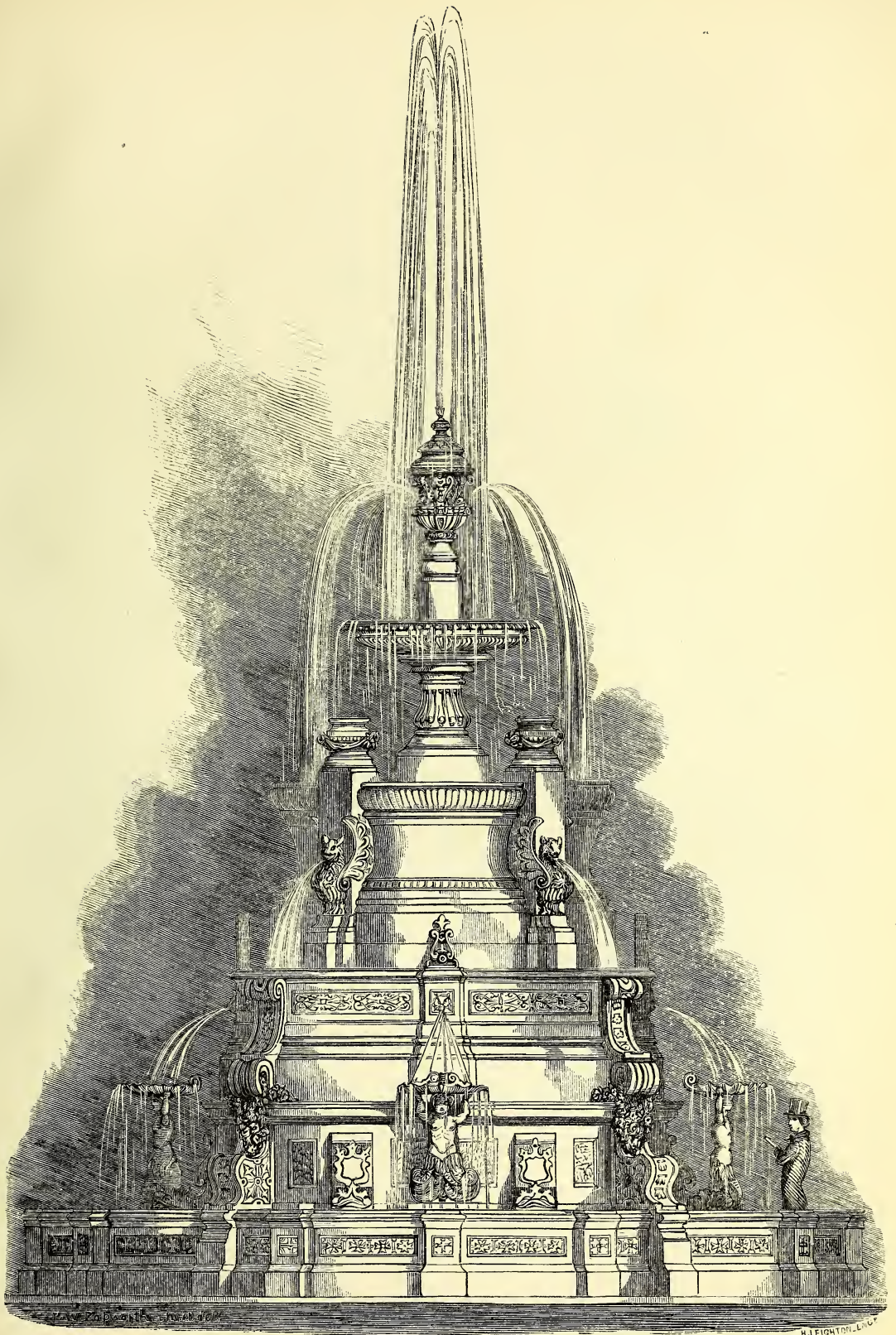

H. LEIGHTON, LONDON



145.

HER MAJESTY THE QUEEN ON HER FAVOURITE CHARGER—HAMMON.
T. AND MARY THORNEYCROFT.



ACIS AND GALATEA FOUNTAIN, ETC. MR. J. THOMAS.

STEPHENS, EDWARD B., 27 *Upper Belgrave Place, Pimlico*—Designer and Inventor.

Satan tempting Eve: see Milton's *Paradise Lost*.

One shaped and wing'd like one of those from heaven
By us oft-seen; his dewy locks distill'd
Ambrosia. * * * * *

* * * * * close at the ear of Eve,
Assaying by his devilish art to reach
The organs of her fancy.

Sketches intended for the decoration of a pedestal for Satan tempting Eve.

Satan vanquished by the Archangel (see Rev. xx.).

A Deer-stalker.

THOMAS, J., *Old Church Street, Paddington and New Palace, Westminster*—Architect and Sculptor.

Statues of Rosamonda and Amphitrite. Bronze statuette of Ariel directing the storm. Statuette of Charity.

The statue of Rosamonda is represented in the accompanying Plate 150.

Model of fountain, comprising shells and marine plants, surrounded by four Tritons, and surmounted with a group of Acis and Galatea. The accompanying Plate represents this fountain.

THOMAS, J. E., 7 *Lower Belgrave Place*—Sculptor.

Model of a colossal statue of the late Marquis of Bute.

THORNYCROFT, THOMAS and MARY, 39 *Stanhope Street, Hampstead Road*—Sculptors.

Classical group, the jealousy of Medea.

Historical group, Alfred the Great receiving from his mother the book of Saxon poetry.

Equestrian statue of Her Majesty the Queen riding on her favourite charger Hammon. This statue is represented in the annexed Plate 145.

WALLER, MESSRS., 13 *Howland Street, Fitzroy Square*—Producer.

Executed design for monumental brass to form part of an altar tomb. The subjects in the shafts of the canopy are taken from Matt. xxv. 35, 36; and consist of the Act of Mercy. That in the pediment, the story of the Good Samaritan. On the apex is a group representing Charity; and on the brackets are subjects from Psalm xciv. 10.

WALLIS, Capt., R.N.—Producer.

Vases of Swedish porphyry, presented by the King of Sweden to the late General Sir R. Wilson.

WALTON, W., *Carrara*—Sculptor. Agents, JOHN WRIGHT, *Pimlico*; TOOTAL & BROWN, *Pimlico*, and 73 *Piccadilly*.

Statue of Victory, modelled by Professor Rauch, of Berlin; the original in the king's palace. In Carrara marble.

WEEKES, HENRY, 29 *Lower Belgrave Place*—Sculptor.

Plaster group, the Suppliant.

Statue of the Marquis of Wellesley, executed in marble for the Honourable East India Company.

"Resting after a run," portrait of Miss Reed.

A Sleeping Child and Dog. The annexed engraving represents this statue.

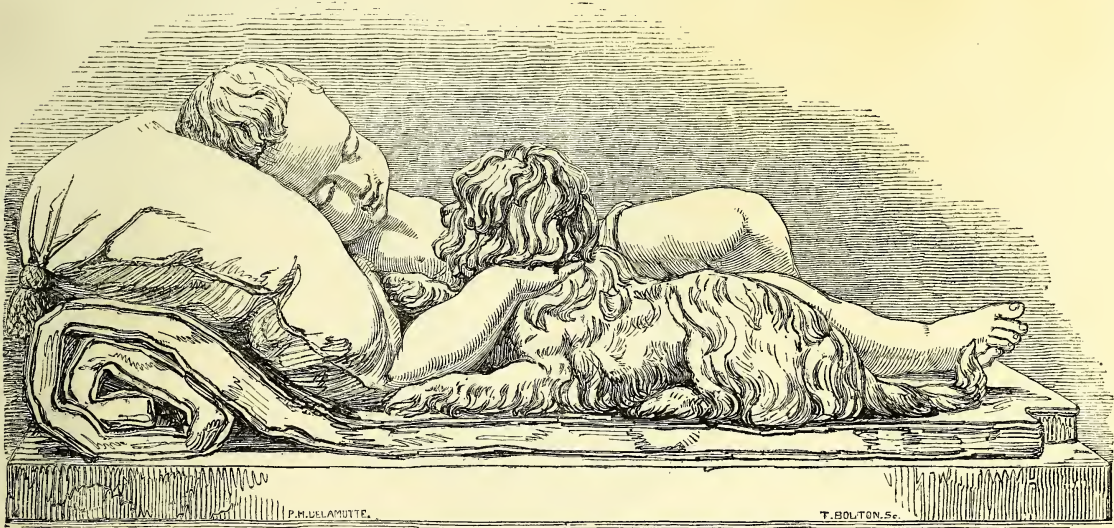

Weekes' "Sleeping Child and Dog."

WILLOCK, E. P., & Co., *Ladyshore, Bolton-le-Moors*—Manufacturers.

A model of a decorated Gothic church built in the year 1842, at Lever Bridge, Bolton, Lancashire, and designed by Edmund Sharpe, Esq., architect. The church is almost entirely built, both inside and out, with Ladyshore terra-cotta. The pulpit, reading-desk, benches (which are all open), organ-screen, and the whole of the decorations, are made of terra-cotta. The church will hold about 500 persons, and cost something under 3,000l. The model is all terra-cotta, and made on a scale of two inches to one foot.

This model is exhibited with the sole view of drawing attention to the material as adapted to architects' and builders' purposes, and not as a specimen of Gothic design.

Ladyshore terra-cotta is from 50 to 75 per cent. less costly than carved stone or wood.

WOODINGTON, WILLIAM FREDERICK, 2 *Charlotte Place, Upper Kennington Lane*—Sculptor.
Young Girl at the Spring.

WYATT, JAMES, 33 *Dudley Grove, Paddington, and 33 Spital Square*—Sculptor.

Equestrian statues of Her Majesty the Queen and of H. R. H. Prince Albert, full size, designed for bronze.

WYATT, M. C., *The Grove, Paddington*—Designer and Sculptor.

Equestrian group in bronze, life size: The Horse and Dragon.

WYATT & BRANDON, 77 *Great Russell Street, Bloomsbury*
—Architects.

Model in card (by Mr. Stephen Salter, Elvar Cottage, Hammersmith, London) of the new church of St. Mary and St. Nicholas, at Wilton, in the county of Wilts, erected by the Right Honourable Sydney Herbert, M.P., from the design of the exhibitors. The exterior is entirely of stone, and interior decorated with marble, mosaic, and painted glass. It is the first example of the introduction of the Romanesque style of architecture into this country. Its length is 156 feet, the breadth 60 feet, height of nave 54 feet, and of campanile 120 feet.

Model in card of the new assize courts for the county, erected at Cambridge, from the designs of the exhibitors. The exterior of the principal front is of Whitby stone, and the fittings of the interior are of oak. The principal feature of the design is the arcade, which is adopted in preference to the more usual one of the portico, for greater public convenience and protection.

CREMER, W. H., 10 *Bridge Street, Westminster*—
Proprietor.

“German Christmas Tree,” a beautiful and correct model of the date palm tree bearing fruit, manufactured

in iron, painted true to nature, and decorated with *bon-bonniers*, illustrating the pleasing and fashionable practice of distributing presents at Christmas and the new year.

It is strictly a German custom, and can be traced back as far as Martin Luther, 1530; and but little known or understood in this country until introduced by His Royal Highness Prince Albert for the amusement of the royal children.

WYATT, M. C., *The Grove, Paddington*—Designer
and Sculptor.

Group and pedestal—mosaic sculpture: “The faithful friend of man trampling under foot his most insidious enemy.”

Four tables and pedestal of inlaid marble.

Gothic vase in terra-cotta.

Rustic chair formed of knots of wood.



Specimens of newspapers published in America.



OFFICIAL
Descriptive and Illustrated Catalogue.

~~~~~  
BRITISH COLONIES AND DEPENDENCIES.

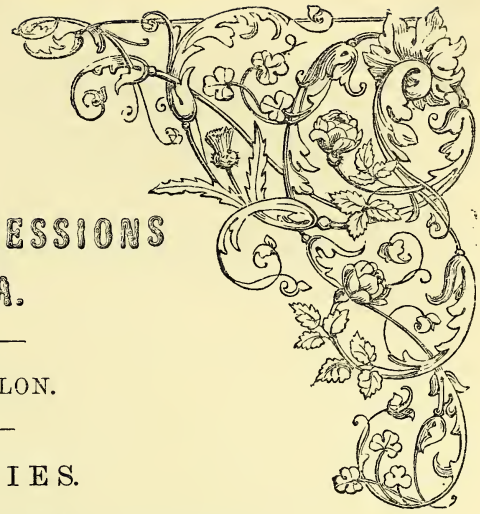



I.  
BRITISH POSSESSIONS  
IN ASIA.

---

INDIA.—CEYLON.

---

EAST INDIES.

NORTH AREAS, C. 33 ; D. E. 33 TO 35 ; F. 33 TO 36 ; G. H. I. 34 TO 36.  
SOUTH AREAS, J. L. M. N. 34 TO 36 ; O. P. 33 TO 36 ; Q. R. 34 AND 35.

“INDIA, vast in extent and diversified in surface, is remarkable as the cradle of one, at least, of the nations who earliest practised the arts and cultivated the sciences which characterise civilization, and from whence these travelled to the West, and, perhaps, also to the East. Its present inhabitants continue to venerate sciences which they know only by name, and practise arts of which they know not the principles ; and this with a skill not only remarkable for the early period at which it attained perfection, but also for the manner in which it has remained stationary for so many ages. But when Commerce was in its infancy, or dealt only in the most precious commodities, these arts could not have been practised unless India had contained within itself all the raw materials which Art could convert into useful articles or elegant ornaments. Without cotton, the so-called ‘webs of woven air’ could have had no existence. Without numerous barks, woods, and flowers, dyeing could not have been practised, and calico-printing would probably not have been invented. If an *Indigofera* had not been indigenous, indigo would never have derived its name from India, nor have afforded us the proof, in the stripe of mummy-cloth, of the early commercial intercourse between its native country and Egypt. Neither would sugar have been arranged by the Greeks with honeys, nor the Indians described as those who ‘*bibunt tenera dulces ab arundine succos,*’ unless they had had the cane-like *saccharum* as a plant of their country. Neither in Persia would the proverb of ‘giving an Indian answer,’ have been considered equivalent to a cut with an Indian sword, unless the Hindoos had possessed the ore which enabled them to manufacture their far-famed *wootz* steel ; and gunpowder is likely to have been invented at an early age only in a country where ‘villanous saltpetre’ is abundant.

“Besides these, India possesses an immense number, both of animal and of vegetable, as well as of mineral substances, well fitted for arts and manufactures of every kind ; and the country has often been described as capable of producing, within its own limits, almost all the useful products of every other quarter of the globe.

“There appear only two available methods by which a manufacturer can be made acquainted with the existence of foreign products likely to be useful in his business ; one is, by the collection of such information as is obtainable respecting them, and arranging it according to the most prominent properties of such substances. When these are so arranged, it is comparatively easy for any one to ascertain whether India, or any other foreign country, contains any useful or ornamental product which might be employed instead of, and be cheaper than, that already in use.

“But with the most simple arrangement and clearly-conveyed information the manufacturer generally would feel little interest about unknown natural products and their strange names, unless he had an opportunity of seeing and of personally examining them. Then a glance of his practised eye, or the slightest handling of a new substance, informs him whether it is likely to be of use for his purposes. The collection, therefore, of such substances, and arranging them also, as above, according to their properties, is the only method calculated at once to interest the public and to give such confidence to the manufacturer as to induce him to submit them to trial. Their exhibition, therefore, is calculated not only to be of great use to the manufacturer, but of essential benefit to such countries as possess many little-known products possessed of valuable properties, and procurable in large quantities at a cheap rate, if a demand could be created for them.

“As India produced the raw material and manufactured it into a costly article, gold and silver have, from the earliest times, been required to purchase this combination of the gifts of nature with the creations of art ; but mechanical invention has deprived the Hindoos of many of the advantages of their position, and they have, in a great measure, lost the commerce which they had themselves created, especially as some of their products were subjected to discriminating duties, which amounted to a prohibition on import into this country. Hence their foreign commerce has not advanced, as might have been anticipated, from the enjoyment in many parts of long-continued peace. But fashion, which here is as fickle as the wind, is in the East as steady as their monsoons, and has fortunately preserved some of their manufactures in their pristine excellence, and which, in any general collection of manufactures, would enable those of India still to hold a conspicuous place.”

The foregoing quotations, from the observations written by the author of the present note on the first announcement, in the summer of 1849, of the Great Exhibition of 1851, indicate the nature of the contributions which were likely to be obtained from India, if measures were adopted suitable to the extent and natural riches of the distant country to be explored. The Court of Directors of the East India Company was one of



the earliest, if not the very first, of the public bodies of this country applied to, to support the Exhibition of the Works of Industry of all Nations. Messrs. Cole and Fuller, in their Report to His Royal Highness Prince Albert, stated that "The Chairman (the late Sir A. Galloway) cordially entered into the proposal, as well as Mr. Melvill, Mr. Peacock, and other officers of the India House, who remarked that there would be mutual advantages of great importance both to India and this country; to India, in calling forth new products, &c., and to this country in furnishing suggestions, &c., and new materials for manufactures." The Chairman shortly afterwards wrote: "I have the satisfaction of acquainting you, for the information of His Royal Highness, that the Court expressed their entire concurrence in the views which I then suggested, and that they will be prepared to give their cordial co-operation in carrying out the wishes of His Royal Highness, by obtaining from India such specimens of the products and manufactures of that country as may tend to illustrate its resources, and add to the interest of the Great National Exhibition, of which His Royal Highness is the patron."

The author of the present notice was desired to submit his views on the mode in which the collection should be made, as well as to prepare lists of the raw products and manufactured articles which it was desirable should be sent from India. As there was no time to be lost, from the great distance of the country, and the wide expanse between its several provinces, the author employed himself in the autumn of 1849 in preparing those lists, which were sent to India by the mail of the 7th of January, 1850, when the Court called the attention of the Indian Government to the occasion when "an opportunity will be afforded for the latent resources of distant provinces, and the skill of the least-known artist, to compete with the produce of the most favoured regions, or the works of the most successful genius.

"It is our wish, therefore, that the objects of the proposed Exhibition should be made known as generally as possible throughout India, and that our several Governments, and those of our servants whose station or pursuits may afford the opportunity for their so doing, should use their endeavours in order to the formation of such of the raw products and manufactures of India as may not only be interesting in a scientific point of view, but may also be subservient to the purposes of commerce and art.

"With regard to raw products, we would refer you to the annexed list and accompanying observations, which have been prepared, under our directions, by Professor Royle;\* and in connexion with the subject generally, we would request your attention to the letter from Mr. Taylor, formerly of your medical service in India, and which appears to us to contain some very useful suggestions." (This referred to the productions, both raw and manufactured, of Dacca and the neighbouring districts.)

This despatch and lists were published in the Government Gazettes of the three Presidencies. Translations of these documents were subsequently ordered to be made and printed for distribution among the natives. The Supreme Government, in a despatch to the other Governments, dated the 22nd February 1850, observe, "That the object which the Honourable Court have in view will be most effectually obtained by entrusting to the supervision of the several Local Governments all the details of the arrangements which it may be necessary to make, such general points only being fixed by instructions from the Supreme Government as may insure a certain degree of uniformity in the proceedings of the Local Governments," &c.

"The general plan of operations which has suggested itself to the President in Council is the establishment of a Central Committee at the seat of Local Government, and the appointment of as many subordinate Committees in different parts of each Presidency as may appear in the judgment of the Local Government to be called for." (Individuals of different classes of the community, natives as well as Europeans, were directed to be placed on these Committees.)

"The subordinate Committees, as well as the Central Committees, should each be furnished with a copy of the Honourable Court's despatch and its enclosures.

"The subordinate Committees should be instructed to prepare, with all practicable expedition, for transmission to the Central Committees, Reports similar to that furnished by Mr. Taylor in the district of Dacca, with lists of articles of every description which in their opinion it would be desirable to transmit to the Exhibition from the circle of country placed within the range of their Report.

The lists prepared by the different Local Committees were directed to be sent to the Central Committee of each Presidency, to be submitted to careful revision and comparison, and to be embodied into one general list, to be transmitted to the Government of India.

"The lists rendered to the Supreme Government will thus comprise all the articles which it is proposed to forward to England from the whole extent of territory situated within the limits of the four Presidencies of Bengal, Agra, Madras, and Bombay; they will also show roughly the cost of procuring the articles; and the Supreme Government will thus be able to form some definite judgment in regard to the expense which it will be necessary to incur in this undertaking."

But, on a reference from the Central Committee, the more elaborate articles of manufacture, requiring time for their preparation, were at once ordered.

The Indian Government, moreover, authorized the remission of export duty on all articles that might be sent by private individuals to the Exhibition under certificate of the General Committee, also the payment of the insurance charge on all articles thus sent; and, in the event of the goods being sold in England, would "not desire to receive from the owners either the insurance charge or the amount of export duty remitted."

The Government also concurred, "with the Calcutta Central Committee, in considering it advisable that it should be made generally known, that any premium which may be awarded to an article at the Exhibition will be given to the party from whom that article was procured by the Government." They also approved of a notification being issued to that effect.

The expanse of territory over which these operations were to be carried on and completed in the course of a few months, in order to give time for the arrival of the goods by sea round the Cape of Good Hope, extends from Singapore on the south to Lahore on the north, and from Assam on the east to Aden on the west. The

\* These observations and lists have been republished by the Author in his work on the Culture and Commerce of Cotton in India, 1851.

energy of the Governments, and the efficiency with which the several Local and General Committees have performed their respective tasks, are self-evident, from the extended series of objects displayed in the Indian compartment of the Exhibition, and which are sufficiently complete to give a good general idea of the resources of the country and of the habits of the people, as well as of their ingenuity, skill, and taste as manufacturers. The only defect is the absence of the names of many of the parties from whom the articles were purchased by the Government officers, as this may deprive some of them of the distinction of a reward to which the article may appear to be entitled.

The Central Committee at CALCUTTA was presided over by Sir Lawrence Peel, with Dr. J. M'Clelland as Secretary. The following Local Committees were established within the limits of the Bengal and Agra Presidencies :—

|                                |                                                                          |
|--------------------------------|--------------------------------------------------------------------------|
| <i>Singapore</i> . . . . .     | The Hon. Lieut.-Colonel Butterworth, C.B.,<br>T. Oxley, M.D., Secretary. |
| <i>Moulmein</i> . . . . .      | Major A. Bogle.                                                          |
| <i>Arrakan</i> . . . . .       | Captain A. P. Phayre.                                                    |
| <i>Chittagong</i> . . . . .    | R. Torrens, Esq., C.S.                                                   |
| <i>Assam</i> . . . . .         | Major F. Jenkins; Captain E. A. Rowlett.                                 |
| <i>Dacca</i> . . . . .         | R. H. Mytton, Esq., C.S.                                                 |
| <i>Moorsheadabad</i> . . . . . | T. Taylor, Esq., C.S.; Lieut. T. P. Layard.                              |
| <i>Cuttack</i> . . . . .       | F. Gouldsbury, Esq., C.S.                                                |
| <i>Chota Nagpore</i> . . . . . | J. H. Crawford, Esq., C.S.; Lieut. Jas. Emerson.                         |
| <i>Patna</i> . . . . .         | G. Gough, Esq., C.S.; E. Lushington, Esq., C.S.                          |
| <i>Benares</i> . . . . .       | E. A. Reade, Esq., C.S.                                                  |
| <i>Allahabad</i> . . . . .     | R. Temple, Esq., C.S.                                                    |
| <i>Rohilkund</i> . . . . .     | H. Pidcock, Esq., C.S.                                                   |
| <i>Agra</i> . . . . .          | W. H. Tyler, Esq., C.S.                                                  |
| <i>Delhi</i> . . . . .         | Sir T. Metcalfe, Bart., C.S.                                             |
| <i>Meerut</i> . . . . .        | C. Gubbins, Esq., C.S.                                                   |

A Committee was further established, under the Board of Administration, at Lahore, consisting of R. Montgomery, Esq., C.S., as President; Major M'Gregor and Mr. H. Cope as Members; and Lieut. Tronson, Secretary. Articles from the Punjab generally, from Lahore, Loodianah, Puttialla, Saharrunpore, Jullundur, Kangra, Cashmere, and Huzara were obtained by this Committee, and sent down the Indus to Bombay, whence they were brought, *via* the Red Sea and Mediterranean, to Southampton.

Communications were also sent by the Government of India to the different native Governments of Lucknow, Nepal, Gwalior, Nagpore, Hyderabad, &c., from most of whom contributions have been received, as enumerated in the following Catalogue; and to the Governor-General's Agent in Rajpootana.

In the BOMBAY Presidency a Central Committee was established, with Sir W. Yardley as President, Dr. Henry Carter as Secretary, and Dr. Gibson as Corresponding Member.

Local Committees were established in Scinde under the Commissioner, R. Pringle, Esq., with Captain Preedy as President at Kurrachee, and Sub-Committees at Hydrabad and Shikarpore.

|                                         |                                                  |
|-----------------------------------------|--------------------------------------------------|
| <i>Aden</i> . . . . .                   | Captain S. B. Haines.                            |
| <i>Ahmedabad and Kaira</i> . . . . .    | C. M. Harrison, Esq.; Assistant-Surgeon Leaward. |
| <i>Surat and Broach</i> . . . . .       | W. C. Andrews, Esq., C.S.; A. K. Forbes, Esq.    |
| <i>Tannah and Rutnagherry</i> . . . . . | J. S. Law, Esq., C.S.; Dr. Grierson.             |
| <i>Candeish</i> . . . . .               | A. Elphinston, Esq., C.S.                        |
| <i>Ahmednuggar</i> . . . . .            | R. Spooner, Esq., C.S.; Captain Gaisford.        |
| <i>Poona</i> . . . . .                  | Col. Grant, B.E.; J. H. Pearl, Esq.              |
| <i>Belgaum</i> . . . . .                | H. W. Reeves, Esq., C.S.; Capt. Shortrede.       |
| <i>Sholapore</i> . . . . .              | J. D. Inverarity, Esq., C.S.; R. Hoskins, Esq.   |

Communications were also sent to His Highness Meer Ali Moorad, His Highness the Rao of Cutch, to Kattywar through H. Lester, Esq., to Baroda through Lieut.-Colonel Outram, and to Indore and Malwa generally through R. A. C. Hamilton, Esq., the Resident at Indore; Sattara to H. B. Frere, Esq.; Kolapore and Sawrit Warra, Major Jacob. From all which places contributions have been received.

In the MADRAS Presidency the Central Committee was presided over by W. A. Arbutnot, Esq., with Dr. Balfour as Secretary; and Local Committees were established at the following places :—

|                                                          |                               |
|----------------------------------------------------------|-------------------------------|
| <i>Bellary, including Cuddapah and Kurnool</i> . . . . . | Brigadier-General Steel, C.B. |
| <i>Canara</i> . . . . .                                  | T. L. Blane, Esq.             |
| <i>Coimbatore</i> . . . . .                              | E. B. Thomas, Esq.            |
| <i>Ganjam and Vizagapatam</i> . . . . .                  | Walter Elliott, Esq., C.S.    |
| <i>Rajahmundry, Guntoor, and Masulipatam</i> . . . . .   | Walter Elliott, Esq., C.S.    |
| <i>Madura and Tinnivally</i> . . . . .                   | C. R. Baynes, Esq.            |
| <i>Trichinopoly and Salem</i> . . . . .                  | T. E. J. Boileau, Esq.        |
| <i>Tanjore</i> . . . . .                                 | J. F. Bishop, Esq.            |
| <i>Malabar</i> . . . . .                                 | H. V. Conolly, Esq.           |
| <i>Travancore and Cochin</i> . . . . .                   | Major-General Cullen.         |
| <i>Mysore</i> . . . . .                                  | The Commissioner of Mysore.   |

The Central Committee of Madras express themselves particularly indebted to the exertions of the Bellary Local Committee, and to those of the following gentlemen :—J. Rhodes, Esq., Colonel Tulloch, C.B., Captain R. L. Ogilvie, D. Mayew, Esq., Rev. C. F. Muzzy, and Dr. Wright.

The Bombay Government, in issuing a notification on the subject, dated 10th April, 1850, justly observed—  
“An equally favourable occasion is not likely again to offer for making Europeans acquainted with many of

the productions and manufactures of India, at present but little known. The man of science, the merchant, the manufacturer, and the artist will be prompted to visit the Exhibition of 1851, not so much by curiosity as by interest, and each and all of them will find their account in encouraging a demand for such of these productions as may prove to be valuable from their properties or likely to be brought into request by their ingenuity or the delicacy of their workmanship."

The General Committee of the Presidencies of Calcutta and Bombay, as well as the Local Committee of Singapore, prepared lists of the articles sent, arranged according to the classification issued by the Scientific Committees appointed by the Royal Commissioners in the spring of the year 1850. The Bombay and Singapore Committees have sent with their lists observations respecting several of the articles sent. The Calcutta Committee printed their list, of which several copies were received and many have been distributed; but, unluckily, a series of numbers differing from those under which the articles were sent have been employed in this Catalogue. The Madras Committee have printed the whole of the Reports received from their Local Committees, and a great mass of valuable information for future use has thus been brought together. Extracts have occasionally been made from these several documents; but the following Catalogue was prepared from the Invoices as they arrived, and according to the thirty Classes of the Head Juries.

## SECTION I.—RAW MATERIALS AND PRODUCE.

### CLASS 1.—MINERAL PRODUCTS.

[From the southern portions of India approaching so near to the Equator, while its northern provinces are nearly in the latitude of the southern parts of Europe, we may form some idea of the great extent of Indian territory, and be prepared to find great diversities of climate and consequently of the productions of every kingdom of nature, from the long-extended coasts, washed by a tropical ocean, to the tops of the several ranges of mountains, among which, as among those of the world, the Himalayas stand pre-eminent, whether we consider their extent or elevation, their diversity of climate, or of production.

As the form and slope of the country, the direction of the rivers, and the climate of the different parts, depend in a great measure on the direction and elevation of the mountain ranges, as well as the soil on their mineralogical composition, it is obvious that before proceeding to their mineral contents or to other subjects, we should first obtain a general idea of the number and position of the several mountain ranges of India, and this may be conveniently done by taking them, as they naturally form separate ranges:—first the Western and secondly the Eastern Ghauts, which run parallel to the Malabar and Coromandel coasts; thirdly, the Vindhya or Central zone of India, extending all across the continent of India, from Monghir and Rajmahl, on the Ganges, to the hilly tracts of Guzerat, on the West; fourthly the Himalayas, which form the great north-eastern boundary of India.—ROYLE. *Introduction to Himalayan Botany.*

Few minerals or ores of metals have been sent from the Himalayan mountains, though these abound in iron, copper, and lead. The mines have only been worked superficially, but it is doubtful whether they would repay any great outlay. Graphite has been found in Kemaon, and traces of lignite in the tertiary formation, where the immense deposit of fossil bones have been discovered.

From the extreme eastern and western points of the Central zone, that is, from the Saone and Kane rivers on one side, and from Cambay on the other, a great variety of agates and cornelians have been sent. From the different States which intervene between the ramifications of this range and the great desert on the north-west of India, we have ores of metals and specimens of marbles, with works in stone and marble. Mines of copper and of lead occur in these regions, and iron is abundant. The only large collection of minerals which has been received is from the Madras Presidency, in which the variety of kaolins are

particularly interesting. These are likely to be useful in the arts, and some of the earths as colours.

The deposits of coal stretch across India from east to west, that is, from Assam into Silhet and Burdwan, and along the course of the Nerbudda, as well as in the western district of Cutch.

From the Tennasserim coast, as well as from Borneo, oxide of tin has been sent, as well as sulphuret of antimony from the latter, where both are very abundant.]

#### 1. *Metals and their Ores.*

INDIAN IRON AND STEEL COMPANY, *Beypore, near Calicut, Malabar, and at Porto Novo, near Cuddalore, Carnatic.* Office in London, 10A *King's Arms Yard, Moorgate Street*—Producers, Manufacturers, and Importers.

Specimens of the ores and charcoal used, viz.:—

Magnetic oxide, from Salem and South Arcot.

Crystals of the magnetic ore.

Ore as prepared for the blast furnace.

Argillaceous iron-stone, from South Arcot.

Charcoal used in the manufacture.

Specimens of the pig iron from the blast furnace.

The pig iron refined.

Specimens of annealed castings made from the pig, viz.:

Chain 5-16ths, cast entire in links.

Flier used in worsted spinning, hitherto made only of wrought iron.

Springs cast, as the above, from the pig iron, and drawn down. Onions' patent.

Specimens of the wrought iron:—

Bars fractured to show the fibre and colour.

Specimens worked and twisted cold, to show tenacity and flexibility.

The iron drawn into wire, Nos. 7, 18, 22, 25, 30, to show ductility and tenacity.

Specimens in screws, horse nails, rollers, axles, gun-barrels, &c.

The bar iron for steel purposes:—

Bar steel.

Cast steel ingot, showing its colour and crystallization.

Cast-steel drawn to sizes, and fractured to show colour and temper.

Specimens of files, saws, chisels, gouges, and plane-irons.

Table knives and carvers.

Razors, scissors, and knives, fine cutlery.

Sword blades.

[From these magnetic ores of iron the "Wootz," or Indian steel, is made by the natives; also malleable iron by the direct process. The ore when cleaned from the quartz with which it is found combined, is shown by analysis to contain 72 per cent. of iron with 28 of oxygen, and traces of manganese and lime without any other

admixture. The manufacture of iron in India from these ores by European methods was established by this Company some years ago, and their produce has been imported to a considerable extent into this country, but chiefly in the shape of pig iron hitherto. Charcoal is exclusively used as fuel in the manufacture.]

Specimens of chrome ore from the Company's mines in the Salem districts.

Samples of the chromate and bichromate of potash manufactured from this ore.

Dr. Andrew Ure found this ore to be 30 per cent. richer in colouring matter than the best Baltimore ore.

Iron ore; cutties, or blooms of iron; palms, or bars of iron; vuttoms, or pieces of cast steel, as it came from the clay crucible; ollies, or bars, drawn out from clay crucibles; small bag of iron beads which ooze out from the blooms in the blast furnaces; steel made from the blooms in the same kind of blast furnace, and used in making edged tools—from Salem.—F. G. Fischer.

R. A. C. HAMILTON, Esq., Indore.

1 Specimens of iron ore, iron, and the wood which is used in smelting it, from Indore.

The following is Mr. Hamilton's account of the process, with a section of the furnace.

"The furnace (A) in which the ironstone is melted is excavated out of the ground, about 12 by 10 feet, and 10 feet deep; the furnace is made of clay, plastered with cow-dung (heaped). Double (B) bellows are fitted, airtight at the bottom, worked by a man sitting between them. At the bottom of the furnace is an earthen sieve (C) through which the dirt and refuse drop. The holes are filled with earth at first, but this gives way as the iron melts and comes down; when choked the holes are opened by an iron poker (D), the drops and dirt fall to (E). The fire is formed of caked cow-dung (F) broken small, charcoal (G) and unjien (I) kheir (J) wood. The wood is put on the top part, a layer (H), ironstone broken the size of marbles is placed about one inch in thickness, then a layer of cow-dung (I) and charcoal, and so up to the surface, when the ironstone is piled about 18 inches, and covered in with the wood cut into small billets. After four hours' incessant plying of the bellows, the furnace has attained a heat which makes the first layer of stone melt and the dross fall through; the whole mass has become gradually heated, and as it falls, the stone on the top which is regularly served keeps falling into the furnace. In this way the furnace is plied and filled for 12 hours, the bellows going the whole time; the furnace is now left to cool, and according to the season, is ready to open in from 12 to 24 hours."

The iron will amount to about 40 lbs. weight, 20 seers, which at the pit, including digging the stone, fire-wood, and every charge, sells so that the profit averages one rupee per seer: the people consequently work only as their wants require, and not regularly.

Nothing more is done by this class of workmen: the iron is sold as it comes out of the furnace, and worked up by another class.

Iron ore and iron, from Cutch.—Rao of Cutch. Manufacture of iron in Cutch:—"In extracting the metal in Cutch, layers of very small pieces are disposed alternately with others of charcoal, in a rude open furnace, and exposed to the blast of two small bellows made of sheepskins. The metal when fused, falls into a hole at the bottom of the furnace, when it is transferred to an enclosed furnace, and subjected to similar blasts until brought to a white heat, when it is taken out and beaten into a bar. No flux of any kind is used."—*Captain Grant's Geology of Cutch*, page 293.

Details of the expenses of manufacturing 140 lbs. of iron:—

|                           |          |
|---------------------------|----------|
| One cart-load of material | Corries. |
| Miner . . . . .           | 2        |
| Miner . . . . .           | 1        |

|                                                 |          |
|-------------------------------------------------|----------|
| Master . . . . .                                | Corries. |
| Manager of charcoal . . . . .                   | 1 1/4    |
| Director of second furnace . . . . .            | 3 3/4    |
| Three hammer-men . . . . .                      | 1 1/2    |
| Two bellows-men at 1/2 each . . . . .           | 1        |
| Four bellows-men of 3/4 each . . . . .          | 3        |
| A breaker of the material for each cart-load    | 1/4      |
| Cart of charcoal . . . . .                      | 8        |
| Second smelting charcoal . . . . .              | 3        |
| Tax for five maunds or 140th, (a day's produce) | 5        |
| Sundries for beggars, hire of bellows, &c.      | 2 1/2    |
| Tobacco for men . . . . .                       | 1/4      |

Total 32 or 16s.

"This is the cost of one day's produce, or five maunds, at 40 seers a maund, one seer-weight, 40 piece-weight.

"A cart-load of mineral, after 18 hours' smelting in the open furnace, yields 10 maunds (280 lbs.) of pig iron, and that again yields 5 maunds (140 lbs.) after 9 hours' smelting in the closed furnace."

- Ironstone, Soane River.
- Iron ore bisulphuret embedded in stone, from Cuddapah.
- Iron ores, magnetic, from Vizagapatam.
- Iron ore and two pieces iron, from Mugraonee Mine, Gwalior.—Maha Rajah Rao Scindiah.
- Iron ore and two pieces iron, Dhooab Mine.
- Iron, smelted, and iron ores; ferruginous concretions, from Teroo, in Assam.—Capt. Brodie.
- Iron ore and smelted iron, from Shahabad.—Rajah of Kotah.
- Iron ores, from Talagaoon.
- Iron ore and unwrought iron, from Hazareebagh.
- Iron, from Chota Nagpore.
- Iron ore, from Cossya Hills. Iron sand, from Assam.
- Bag of iron ore and iron, from Nepal.
- Iron, from Banglee Mines, Bombay.
- Iron ore, from Ulwar.—Rajah of Ulwar.
- Iron ore, from newly-discovered mines in Beerbhoom.
- Iron and steel in different stages, from Salem, &c.
- Flat iron specimens; half-roasted iron; lump, crude, and raw iron; and iron smelted, from Cossya Hills.
- Iron ore, from the Tennasserim provinces. There is a large variety of iron ore in these provinces, some of which is very rich in metal, especially in the Tavoy District. Near the river-side, about three miles from the town of Tavoy, is a hill which, according to the local authorities, appears to consist almost wholly of magnetic oxide of iron. Common iron pyrites is also very abundant in the provinces.
- Manganese, from the Mergui District, in the Tennasserim provinces, where large quantities exist. It is not made use of by natives.
- Antimony sulphuret, from Tennasserim and Madras.
- Smelted antimony, from Borneo.
- Pyrites, from Cuddapah.
- Copper ore from Ulwar and Beerbhoom.
- Copper ore, from Bellary.
- Copper ore, from Dhumuara.
- Copper ore, from Tennasserim and Nepal.
- Lead of superior quality, from Sookpoor.
- Lead ores and lead, from Tennasserim and Nepal.
- Lead ores, from Bhoondie and Beerbhoom.
- Lead ore, supposed, from Singapore.
- Tin ore, from Tennasserim and Malacca.
- Tin, from Malay Peninsula, &c.
- Tin, oxide of, from near Mergui in the province of Tennasserim.
- Chromate of iron, from Salem.
- Cinnabar, and in its original state. This is said to be superior, as obtained from Surat, to the China vermilion, but none has been supplied. Orpiment, from Nepal.
- Gold dust, from Singapore and Nepal.
- Gold-washers' sand, from Assam.—Major Hannay.
- Silver box of gold-dust, villages of Kapoo and Nelum-

boor — from Ernaad Talook, Calicut, and Wynaad, Malabar.

Bell metal, from Bellary and from Rajah of Kota.  
Pewter, from Nepal.

## 2. Non-Metallic Mineral Products.

Moss agates, from Nerbudda, Soane, and Kane Rivers. Species of agate, from Soane River, Kane, and Nerbudda.

Calcedony, from Soane River.

White agate, from Saugur.

Pebbles, from Soane River.

Agates, from Ahmedabad.

Bloodstones, from Kane River, &c.

Chitta hindnee, piebald or spotted, from Jubbulpore.

Grass stone, from Betool River.

———— ? Bincole in Saugur.

Lapis lazuli, locality unknown.

———— ? Kane River.

Carnelian, from Kumack.

———— ? from Soane River.

———— ? sort of gold stone, locality not known.

Carnelians and onyx, from Ahmedabad.

Jasper and marble, from Bengal.

Strings of Nimluck beads; plain and diamond-cut carnelian; greenstone and mother-of-pearl beads; mother-of-pearl buckle; black stone earring drops; large and small pieces of crystal; carnelians for brooches; stones for clasps; bloodstones; gowries; large and small amethysts; large and small emeralds; rajawahs; assorted stones; ferozahs; sapphires; cat's-eyes; garnets; romarooks; salamin-stone; blue-stone; turquoises. Purchased from native lapidaries of Calcutta.

Agates, &c. from Cambay. The following account has been drawn up by Mr. Augustus Summers, senior apothecary, Cambay:—

*Articles wrought by the Cambay Lapidaries.*—(For sale to the gentry passing through Cambay, and sent to Bombay for the English, Calcutta, and other markets.)

The whole of the agates, bloodstones, and carnelians are made use of, and worked into models of cannon with carriage and appurtenances complete; slabs for boxes; sets of variety of slabs, twenty in number, to form a square table; cups and saucers; chessmen; flower-vases; pen rack, card and letter rack; watch-stands; inkstands; knife-handles; rulers, paper-cutters, paper-weights, penholders; sets of necklaces; bracelets and brooches of variety of patterns; crooked needles; silk-winders; marbles; braces and shirt-studs; seals; also rough specimens of stone having one side polished.

### *Articles prepared for the China Market.*

Articles wrought for China comprise only two kinds, and are made up entirely of carnelian—first, the oval and square flat stones resembling watch-seals, large and small, named monzligool, worn as armlets and dress ornaments; the other variety is the beads named here dholl, each necklace containing fifty beads, these are all plain, polished, and round. Vast quantities of the above are annually exported from this in chests to Bombay, for China; the extent of valuation is from 50,000 to 60,000 rupees annually.

### *Articles for the Modea, Djedda, and Mecca Markets.*

The descriptions of stone employed are the veined agate from Rhanpore, carnelians from Ruttonpore, the cat's-eye, and the jet or obsidian; these are worked into large quantities of rings, both plain and ornamented; ring-stones, wristlets, armlets, and necklaces, embracing the following variety:—

Necklaces—Pey loodar dholl, cut beads; goocrudar dholl, diamond cut beads; badami arr, almond-shaped necklace; khauttee, oblong flat necklace; chawneelee, spear-shaped; madulyah, jawitch or jahwiz, composed of three stones; sadah khauta, plain round beads, used as a necklace and rosary.

Armlets and wristlets.—Mootea madalyah, composed of two stones, worn as a wristlet; pytah, a wristlet composed of seven round flat stones; pouchea, a wristlet composed of several flat stones; byjootah, an armlet of one stone cut in different fanciful devices; tam ghool, single stones in shape of large flat seals.

Rings.—Rings are made of carnelians, of various devices, named ingotee, and riny; stones for setting, called meggeenia, are made of carnelian and the cat's-eye.

The articles for the Djedda and Mocha markets are packed up in chests, also in bales, with the cloths, and exported to Bombay and Veraval Bunder, near Dica, whence they are transhipped to their destination, and from thence they find their way into Arabia, Persia, Seindh, and Afghanistan, the merchants realising large profits by the sales effected.

### *Mode of Manipulation, or Process by which the different Articles are Wrought.*

Beads.—The following is the process of making beads:—the stones are first broken into pieces of the size desired; an iron spoke, named Khoredia, is driven in the ground in an inclined direction with one point upwards; the stones are placed on this point, and chipped with a hammer made of iron till rounded; it is then passed on to the polisher, who fixes a number of equal size in a pair of wooden or bamboo clams, and rubs them on a coarse and hard polishing-stone called Dholin. They are then transferred to another man, who, securing them in wooden clams, rubs them against a ground polishing-board, named pattyamar, on which is smeared a composition of emery and lac, turning the beads round so that every part of the surface may assume a globular form and become polished. The final polish is given by the beads so prepared being put from one to several thousands into a stout leather bag about 2 feet in length, and from 10 to 12 inches in diameter, with some emery dust and a very fine powder named warry, which is the sediment of the carnelians deposited in the earthen dish, partially filled with water, during the process of drilling holes in the beads, which is always collected and dried. The mouth of the bag is tied up, and a flat leather thong or tape is passed round its centre, and the bag is rolled towards each other by two men, seated at opposite ends of a room, from ten to fifteen days: the leather bag is kept moistened with water. When the beads have taken a bright polish, they are passed on to the people who bore the holes, which is effected by means of a steel drill tipped with a small diamond, during which process the spot is fed with water, drop by drop, passed through a thin narrow reed or metallic tube.

The cut beads are passed from the rough polishing-stone to the lapidary polishing and cutting-plate, and lastly the holes are drilled.

Knife handles.—These undergo exactly the same process as the cut beads, adapting the shape to any pattern.

Cups and saucers, and any other hollow articles, are wrought according to the required external shape on the steel spike, and a rough polish given on the rough polishing stones: the cavity is formed by the diamond-tipped drill to the depth of one-fourth of an inch all over the space until it exhibits an honey-combed surface—the prominent places round the holes are then chipped away; and this process is repeated until the depth and form desired is obtained, they are then polished upon prepared moulds of convex formation, and of the same composition as the polishing plates which are attached to the turning-wheel.

Cannon.—The bore of the cannon is effected by a drill with two diamonds to the depth required, afterwards five others in succession, of proportionate increase in the axes, are substituted, each having an increase in number of diamonds placed circlewise, the last encircling as many as twelve diamonds.

Slabs, Paper-cutters.—Paper-weights, &c., are cut by means of a toothless saw made of iron, fixed to a light wooden frame, and the cut is fed with emery dust and

water. When the stone is small the saw is worked by one man, when large by two men. The stone to be operated upon is attached to a large wooden frame which is itself a fixture partly in the ground. The cement consists of a coarse description of beeswax with the fine fibres of new cloth, by means of which the stones are firmly attached to the wooden framework. Several men in a row are at the same time employed cutting through different pieces of stone.

*Preparation of Polishing Plates or Dishes.*

The plates or dishes are made of emery (named korunge and samadish), a species of corundum of greyish-black colour, glazing lustre, and granular concretion. Its fine powder is obtained by trituration and levigation: this, mixed with the seed-lac, forms the circular polishing plates, two in number. The first, or coarse-grained, is made in the proportion of three parts of ground emery to one of lac; the second, or finer, is made of two and a half pounds of finely-levigated emery to one seer of lac; a third, or finest polishing dish, is composed of warry and lac in equal proportion. Warry is the sedimentary deposit of cornelian in an earthen dish during the polishing

process. A copper dish is occasionally used for very hard stone, such as the Ceylon and other precious stones, and a wooden dish, made of deal or other fine-grained wood, is employed for polishing the softer description of stone.

The following description of the lapidary wheel is copied from the "Bombay Times :"—

"Native Lapidary Wheel.—The wheel consists of a strong wooden platform, 16 inches by 6, and 3 inches thick. In this are two strong wooden uprights; between these is a wooden roller, 8 inches long and 3 in diameter, fastened into a head at the one end: this works on an iron spindle or axle at each end. On the one end the axle is screwed and fitted with a nut, by which the cutting or grinding wheel can be made fast. The lap-wheels consist of two circular discs or cakes of lac with ground korund, coarse or fine according to the work; of a copper disc for polishing the very hard, and a wooden one for finishing the work of the softer, description of stone. These are spun backwards and forwards by a bow, the string of which passes round the roller. The lapidary sits on his hams, steadying the wheel with his foot, and holding on the stone with his left hand while he works the bow with his right."

LIST of various AGATES, CORNELIANS, &c., wrought upon by the Lapidaries at CAMBAY.—14th June 1850.

| Description of Stone.                                                                                                                                                                                                                                                                                                                                                                            | Where Procured.                                                                                                                                       | Quarried or how Procured ;<br>Size and Formation.                                                                                                                           | REMARKS.                                                                                                                                                                                                                                                                                                                 |
|--------------------------------------------------------------------------------------------------------------------------------------------------------------------------------------------------------------------------------------------------------------------------------------------------------------------------------------------------------------------------------------------------|-------------------------------------------------------------------------------------------------------------------------------------------------------|-----------------------------------------------------------------------------------------------------------------------------------------------------------------------------|--------------------------------------------------------------------------------------------------------------------------------------------------------------------------------------------------------------------------------------------------------------------------------------------------------------------------|
| <i>Jasper, Heliotrope, or Bloodstone.</i> —A beautifully-variegated stone of greenish basis. The green with flamed streaks, or red spotted delineations, is named by the lapidary Zuela Chantadur; those more variegated with green, red, and yellow tints, is named Puttolia. It occurs in massive layers, is hard, with a dull fracture, and takes a high polish.                              | Near the village of Tunkaria, in the territory of the Moorvi Rajah, about 12 miles north of Rajcote.                                                  | Found on the hills named Bungaud, below the hill under the strata of soil, in massive layers from $\frac{1}{2}$ lb. to 40 lbs. in weight.                                   | For permission to collect the stone, 8 annas per maund (40 lbs.) is paid to the Rajah, and 2 annas per each bullock-load for passing through his territory, and $4\frac{1}{2}$ rupees bullock-hire to Cambay. A bullock-load contains 3 maunds, on which a town duty of 8 annas is levied at Cambay.                     |
| <i>Mossagate.</i> —Named by the lapidary Sowa Baju. This is a beautiful species of agate, of a very clear or clouded crystalline basis, with impressions of the dark-green moss, or green and reddish-brown moss delineations. Found in massive layers, often cracked in various ways. It is hard, and receives a fine polish.                                                                   | Near the village of Tunkaria, in the territory of the Moorvi Rajah, and at Bood Koten, about 3 miles from Tunkaria.                                   | It occurs in the plain about 2 feet under the surface of soil, in massive layers, cracked, and weighing from $\frac{1}{2}$ lb. to 30 or 40 lbs.                             | Ditto ditto.                                                                                                                                                                                                                                                                                                             |
| <i>Agate, Common.</i> —A mineral whose basis is calcedony, blended with quartz and cornelian. The white or semi-transparent is named Dholu, and cloudy and streaked Jamma. It is generally greyish-white, of different shades. It is pretty hard, brittle, and massive, and receives a high polish.                                                                                              | Near the village of Mahidpore, 3 miles from Tunkaria, in the territory of the Rajah of Moorvi.                                                        | It occurs in the plain, near the surface of soil, in massive blocks, the most perfect not exceeding 5 lbs.; the inferior quality and cracked, as high as 60 lbs. in weight. | Ditto ditto.                                                                                                                                                                                                                                                                                                             |
| <i>Agate, Kapperwaage.</i> —This is a beautiful species of agate, some having the impression of mineralized plants delicately preserved with a clear semi-transparent basis, and is named Barriah; others of variegated shades of colour, with landscape or other delineations, named Aggeah, Ruttea, &c. It occurs in pebbles, or rolled masses, is hard, and receives a high degree of polish. | At Kapperwaage, in the Kairazilla, and in the bed of the river Magain, between the village of Amliala, and Namedwah, about 15 miles from Kapperwaage. | It occurs on the banks and in the beds of rivers, in rolled balls of spheroidal reniform, and amygdaloidal figures, from $\frac{1}{2}$ lb. to 10 lbs. in weight.            | The Bheels search for the stones and sell them to a Borah at Mandwah, from whom the lapidaries purchase at from 3 to 12 rupees per maund, according to quality. It is carted or brought on donkeys to Cambay. Ten maunds of the stone is valued at 100 rupees, on which a duty of $4\frac{1}{2}$ rupees is charged here. |
| <i>Agate, Veined.</i> —Named by the lapidary Dorador, of different shades of white with dark streaks, or a dark ground with white thready streaks, assuming different forms. It occurs imbedded in clayey soil, is hard, and takes a very high polish.                                                                                                                                           | At Khanpore and adjacent villages, named Darpeepa and Ninama, in the Ahmedabad zilla, near Dandookee.                                                 | Found imbedded under the upper strata of soil, in pebbles of various shapes, not exceeding $\frac{1}{2}$ lb. in weight.                                                     | A fee of 2 rupees per cart-load is paid to the Government on the entries, and the stones are carted to Cambay. The cart-load is 40 maunds, which pays a town duty of 2 rupees here.                                                                                                                                      |
| <i>Chocolate-stone.</i> —Assuming its colour, as the name implies; is named Katiah, of a brownish-earthly basis, not very hard, of a dull fracture, and does not take a high polish.                                                                                                                                                                                                             | At Khanpore, near Dandookee, and at Temkaria, in the territory of the Moorvi Rajah.                                                                   | It occurs on the surface, and imbedded a few feet under the soil, in masses from 1 to 8 lbs. in weight.                                                                     | Brought from Tunkaria on bullocks at rate of $4\frac{1}{2}$ rupees per load, and in carts from Khanpore, 15 rupees hire for cart-load, besides the Government fee of 2 rupees per cart-load.                                                                                                                             |

| Description of Stone.                                                                                                                                                                                                                                                                                                                                                                                                                                                                                                                                                                                                                                                                                                                                                                                                                                                                   | Where Procured.                                                                                                                                                                                                                                                                                                    | Quarried or how Procured ; Size and Formation.                                                                                                                                                                                                   | REMARKS.                                                                                                                                                                                                                                                                                                                                                                                                                                                                                                                                                                                                                                                                                                                                                                                                                                                                                                                                                                                                                                                            |
|-----------------------------------------------------------------------------------------------------------------------------------------------------------------------------------------------------------------------------------------------------------------------------------------------------------------------------------------------------------------------------------------------------------------------------------------------------------------------------------------------------------------------------------------------------------------------------------------------------------------------------------------------------------------------------------------------------------------------------------------------------------------------------------------------------------------------------------------------------------------------------------------|--------------------------------------------------------------------------------------------------------------------------------------------------------------------------------------------------------------------------------------------------------------------------------------------------------------------|--------------------------------------------------------------------------------------------------------------------------------------------------------------------------------------------------------------------------------------------------|---------------------------------------------------------------------------------------------------------------------------------------------------------------------------------------------------------------------------------------------------------------------------------------------------------------------------------------------------------------------------------------------------------------------------------------------------------------------------------------------------------------------------------------------------------------------------------------------------------------------------------------------------------------------------------------------------------------------------------------------------------------------------------------------------------------------------------------------------------------------------------------------------------------------------------------------------------------------------------------------------------------------------------------------------------------------|
| <i>Crystal</i> .—Named Phuttnesat: clear transparent stone, resembling glass in appearance, and receives a high polish.                                                                                                                                                                                                                                                                                                                                                                                                                                                                                                                                                                                                                                                                                                                                                                 | At Tunkaria, in the territory of the Rajah of Moorvi.                                                                                                                                                                                                                                                              | Occurs in masses under the surface of soil, from 1 to 20 lbs. in weight.                                                                                                                                                                         | Pays the same duty as the other stones in the Rajah of Moorvi's territory.                                                                                                                                                                                                                                                                                                                                                                                                                                                                                                                                                                                                                                                                                                                                                                                                                                                                                                                                                                                          |
| <i>Variiegated Stone</i> .—Named by the lapidary Mimarian: of a liver-brown earthy basis, with yellowish impressions of shells and annelida (?), having a pretty marble appearance, but does not receive a good polish.                                                                                                                                                                                                                                                                                                                                                                                                                                                                                                                                                                                                                                                                 | At Dhokeewarra, in the Runn, about 60 miles north of Deesa.                                                                                                                                                                                                                                                        | Found in large masses on the hill, and dug up in large blocks at its base.                                                                                                                                                                       | Carted to Cambay.                                                                                                                                                                                                                                                                                                                                                                                                                                                                                                                                                                                                                                                                                                                                                                                                                                                                                                                                                                                                                                                   |
| <i>Lapis Lazuli</i> , or the Azure Stone.—Named here Rajahwarrad: of a deep blue colour and soft earthy basis, with sprinkling of silver or gold in spots. May be known by its beautiful indigo blue colour. It is soft, and does not receive a high polish.                                                                                                                                                                                                                                                                                                                                                                                                                                                                                                                                                                                                                            | Imported here from Bombay. Brought from Persia and Bucharia.                                                                                                                                                                                                                                                       | Said to be found in rounded balls in the bed of rivers.                                                                                                                                                                                          | . . .                                                                                                                                                                                                                                                                                                                                                                                                                                                                                                                                                                                                                                                                                                                                                                                                                                                                                                                                                                                                                                                               |
| <i>Jet Stone</i> (Obsidian).—Named here Kulla: further resembling glass in fracture, not very heavy, and takes a high polish.                                                                                                                                                                                                                                                                                                                                                                                                                                                                                                                                                                                                                                                                                                                                                           | Imported here from Bombay.                                                                                                                                                                                                                                                                                         | It occurs on the hills at Bassorah and at Aden, in large blocks.                                                                                                                                                                                 | . . .                                                                                                                                                                                                                                                                                                                                                                                                                                                                                                                                                                                                                                                                                                                                                                                                                                                                                                                                                                                                                                                               |
| <i>Blue Stone</i> (Perosa).—Assuming various shades of blue. This is a composition resembling glass, soft, and takes a good polish. It resembles the true perosa (turquoise) when highly polished.                                                                                                                                                                                                                                                                                                                                                                                                                                                                                                                                                                                                                                                                                      | Imported here from Bombay. Is said to be prepared in China.                                                                                                                                                                                                                                                        | Brought from China in flat pieces, not exceeding $\frac{1}{2}$ lb. in weight.                                                                                                                                                                    | . . .                                                                                                                                                                                                                                                                                                                                                                                                                                                                                                                                                                                                                                                                                                                                                                                                                                                                                                                                                                                                                                                               |
| <i>Cornelian</i> is named Gharr in the original state. They are cloudy, of various shades of brown, and others of different tints of yellow in the natural state. After exposure to the sun and baking, these assume other tints, as follows: light brown becomes white, dholu, pale yellow, rose colour, gulabi, deep yellow. Red or lall, a mixture of cloudy brown and yellow, becomes white and red, named Ubluckee: another shade of yellow turns pinkish-purple, named Nafurmani; and brown becomes a darker shade, named Emni. The above are quarried in large quantities, and undergo the process of baking; they receive a high polish, and are wrought into flat and round necklaces, bracelets, armlets, stones for seals, chessmen, marbles, studs, &c. The other stones found in the neighbourhood or on the hills, and subjected to the heating process, are as follows:— | At the base of the hills of Bowa Abbas and Rajpeeplee, in the territory of the Naudode Rajah, who is tributary to his Highness the Gaickwar. The Naudode Rajah farms the quarries to native contractors, who pay annually from 2,000 to 2,500 rupees to the Rajah for the sole privilege of collecting the stones. | Quarried or dug up from near the base of the hill in various shapes: the pebbles are imbedded in a soft yellow soil, or in bluish-grey clay, of size varying from a small pebble to 1 lb. in weight, and are chiefly of uneven form and surface. | Between the Bowa Gore and Bowa Abbas hills on the plain are small mounds, from whence the stones are quarried by the Bheels of the district; they excavate to some depth, forming galleries in a horizontal direction about five feet in height and four broad; they are obliged to use a lamp, and work in pairs, one employed with the pickaxe in the quarry, the other at the entrance, who examines the stones by chipping off a piece, retaining the good and rejecting the bad on the spot: when a larger number of men are employed, the galleries are extended in different directions, with air passages. The two men, in 8 or 10 hours, obtain from 10 to 40 lbs., which is brought in the village of Ruttonpore, by the contractor or his people. A quantity is thus procured in the fields; after which many generally dig a trench round a field two feet in depth and three in breadth. In this fires of goats' and cow dung are set up, and the stones in earthen pots, in single rows, are placed in the trench; the fire is kept up from sunset to |
| <i>Mora</i> , or <i>Bowa Gore</i> .—A species of onyx, or dark-coloured cornelian with white veins, or a greyish-white ground with dark veins, assuming various figures, receives a high degree of polish, and is much prized in the Djeddee market. The true onyx, or sala main, is brought here by Mahommedan mendicants, in ready-made strings of beads.                                                                                                                                                                                                                                                                                                                                                                                                                                                                                                                             | On the Bowa Gore and Abbas hills, or at their base, or in the bed of the river formed by the monsoon streams between the hills.                                                                                                                                                                                    | Mora is found on or at the base of the hills, in pebbles not exceeding 1 lb. in weight.                                                                                                                                                          | sunrise, when the chatties are removed and the stones piled away. The contractor attends to the heating process; the stones are once a-year carted to Nemodra, and conveyed in canoes down the river to Brouch, whence they are brought in boats to Cambay. Each bag of 25 maunds pays a duty of 1½ rupees to the British Government at Brouch, in addition to the import and export duty at Cambay. The stones are sold to heads of the lapidary manufactories. The town import duty is 1½ rupees.                                                                                                                                                                                                                                                                                                                                                                                                                                                                                                                                                                 |
| <i>Cat's-eye</i> , <i>Chesumdar</i> .—The principal colour is grey, presenting many varieties usually translucent. It is hard, bears the impression of a cat's or bird's eye more or less perfect, is much esteemed, and receives a high degree of polish.                                                                                                                                                                                                                                                                                                                                                                                                                                                                                                                                                                                                                              | Found on the Bowa Gore and B. Abbas hills, or at their base, or in the bed of the river formed by the rains between the hills, which is dry in the month of October.                                                                                                                                               | It occurs in blunt-edged or rolled pieces; the pebbles are of various shapes and small size, not exceeding 2 oz. in weight.                                                                                                                      | The pebbles are searched for by the Bheels of the district, and disposed of to the contractor at Ruttonpore, who sells them to the head of the different lapidary manufactories at Cambay.                                                                                                                                                                                                                                                                                                                                                                                                                                                                                                                                                                                                                                                                                                                                                                                                                                                                          |
| <i>Roree</i> , or <i>Lussumia</i> .—A yellow pebble, semi-transparent, found scantily with the cat's-eye; receives a very fine polish, and is much esteemed: usually cut for ring-stones.                                                                                                                                                                                                                                                                                                                                                                                                                                                                                                                                                                                                                                                                                               | Ditto ditto.                                                                                                                                                                                                                                                                                                       | Ditto ditto.                                                                                                                                                                                                                                     | Ditto ditto.                                                                                                                                                                                                                                                                                                                                                                                                                                                                                                                                                                                                                                                                                                                                                                                                                                                                                                                                                                                                                                                        |

| DESCRIPTION OF ARTICLES.                                                                        | Amount, Rupees. |     |
|-------------------------------------------------------------------------------------------------|-----------------|-----|
|                                                                                                 | From            | To  |
| A cannon, with carriage, and timber carriage and appurtenance complete . . . . .                | 200             | 250 |
| A cannon, with carriage, of moss or other agates, or bloodstone . . . . .                       | 70              | 100 |
| A set of chess-men, of any two varieties of stone . . . . .                                     | 75              | 100 |
| A set of variegated slabs, twenty pieces to form a small square table . . . . .                 | 35              | 45  |
| An oval slab and pedestal, forming a miniature table . . . . .                                  | 25              | 35  |
| A large cup and saucer, of agate or bloodstone . . . . .                                        | 40              | 50  |
| A cup and saucer of small size, ditto . . . . .                                                 | 10              | 20  |
| Slabs large, six pieces of different, or one description of stone, to form into a box . . . . . | 35              | 50  |
| Slabs, a pair, to form the top and bottom of a box, large . . . . .                             | 8               | 15  |
| Slabs, a pair, to form the top and bottom, of smaller size, for snuff or other box . . . . .    | 3               | 6   |
| A pen-rack, with ink-stand and pen-holder . . . . .                                             | 20              | 25  |
| A watch-stand . . . . .                                                                         | 8               | 10  |
| A letter or card-rack . . . . .                                                                 | 10              | 12  |
| A flower-stand or vase . . . . .                                                                | 20              | 30  |
| Knife-handles, of good description . . . . .                                                    | 12              | 18  |
| Butter-knife-handles, of agate or bloodstone . . . . .                                          | 3               | 4   |
| Rulers, of agates, bloodstone, &c. . . . .                                                      | 3               | 5   |
| Paper-cutters, ditto, of sizes . . . . .                                                        | 1               | 3   |
| Paper-weights, of different sizes and patterns . . . . .                                        | 3               | 6   |
| Rough specimens of stones, one side polished . . . . .                                          | 3               | 4   |
| Stones for brooches, of different patterns . . . . .                                            | 1               | 4   |
| Bracelets, of variety of patterns . . . . .                                                     | 4               | 8   |
| Necklaces, of ditto, ditto . . . . .                                                            | 4               | 10  |
| Crochet needles, pen-holders, and seals . . . . .                                               | 1               | 3   |
| Braces, studs, and coat-button studs . . . . .                                                  | 3               | 4   |
| Shirt studs . . . . .                                                                           | 1               | 1   |
| Marbles, of different sizes . . . . .                                                           | 1               | 2   |
| Cornelians, stamps for engraving initials or crests . . . . .                                   | 3               | 6   |
| Ear-drops, with tops to match . . . . .                                                         | 1               | 3   |

TABLE prepared from the CAMBAY CUSTOM-HOUSE RETURNS, exhibiting the Value of the Traffic in Wrought Cambay Stones, and Export Duty thereon, for two official years, 1848-49 and 1849-50, commencing in May and ending in April.

|         | Small Packages. | Large Package. | Bamboo Basket. | Large Box. | Bags of Cornelian sent in large Bales of Cloth. |       | Total Value of Cornelian sent each Year. |    |    | Customs' Duty on the part of the British Government. |    |    |
|---------|-----------------|----------------|----------------|------------|-------------------------------------------------|-------|------------------------------------------|----|----|------------------------------------------------------|----|----|
|         | Bundry.         | Kersa.         | Kindin.        | Patie.     | Bales.                                          | Bags. | R.                                       | A. | P. | R.                                                   | A. | P. |
| 1848-49 | 10              | 3              | 13             | 23         | 49                                              | 312   | 108,422                                  | 0  | 0  | 1,350                                                | 4  | 0  |
| 1849-50 | 18              | 1              | 11             | 6          | 98                                              | 536   | 94,902                                   | 0  | 0  | 1,186                                                | 4  | 6  |

In the above table, the export duty levied by the Nawab is not given: the amount exactly trebles that of the British Government, which is calculated at one rupee and four annas per cent. on valuation; this is independent of private fees levied by the Nawab's native officials.

The agate and cornelian trade forms a subject of much interest, but its "modus operandi" has hitherto excited little attention: no desire has been manifested to acquire a knowledge of its varied and complex process, from first procuring the stones in the rough state, to the ultimate perfection of finish arrived at by the art of the lapidary at Cambay. This I have now attempted to describe in detail; and from the foregoing statement of the different agates and cornelians, it will be evident that though they still bear the name of Cambay stones, and this place has held the reputation for a considerable time of being famed for its stone quarries, they are actually brought here in the rough state from different parts of Guzerat, and are only wrought in the lapidary workshops established here for upwards of a century; and although the value of the traffic has been considerably reduced of late years it still forms, next to cloth, the principal article of commerce, yielding a good profit to the traders, forming a valuable source of revenue to the State, and giving employment to nearly two thousand people engaged in the manipulation of the articles in the busy workshops, amounting in all to about seventy-five large and twenty-five small shops.

The traders consist of about fourteen Bannians and Borah merchants, who purchase the wrought articles from the heads of the lapidary workmen, and send them to Bombay, Djedda, and other ports.

The workmen or artificers form a distinct corporate body called the ukkeekia jamut, or punchayat, and are designated as follows:—100 ukkeekias, master artificers, or heads of establishment; 300 gaseas or workers on the lapidary wheels; 200 dhoolias or polishers on the rough and hard polishing-stone; 50 puttymars or polishers on the wooden frame; 100 badars or borers, those employed on the drilling process—750 in number. These form the punchayat, or regularly constituted trades' craft. Besides which, upwards of a thousand people are employed in the different shops as day-labourers in the chipping process, cutting slabs, &c.; they consist of men and boys of both Hindoo and Mahomedan faith.

The punchayat holds the power of adding to their community—the party so privileged, paying a fee of a hundred rupees for his admission into the craft, which is spent in dinners. Each department of labour remains distinct; the artizan in one branch will not interfere with or undertake the work of another branch, and each enjoys distinct privileges appertaining to his particular department needless to notice here.

Coal, from Hooz Mine, Arracan, and from Mergui.  
Coal, and accompanying rocks, from Singrowlee.—  
Worked by the Messrs. Hamilton and Co. of Mirzapore.  
Coal, from Kurhurbalee.  
Coal and coke, from Assam.  
Coal, from Indurgerba and Badum, and from Cossya Hill.  
Coal, or lignite, from the Trombow River, in Cutch.  
Coal, from Nepal and Burdwan coal mines.  
Petroleum, from Silhet, Assam, Arracan, Akyab, and Cheduba.



Doopashapomie resin in earth; heerakussee, variety of amber; from Murr.

Mineral resin (amber), from Cutch. This is dug up with the coal at the Trombow River.

Sandstone, from Gwalior.

Sulphur and saltpetre, from Nepal.

Sulphate of iron.

Carbonate of Soda, from Cuddapah and Bellary.

Carbonate of soda, nearly pure, prepared from Dhoby's (Washerman's) earth.—Professor Key.

Salt, from Tanjore and Vizagapatam.

Saltpetre of Maganore and Errode. Potash, nitrate of, or saltpetre, from Coimbatore and Bengal.

Pearlash, from Madras; pearlash prepared from nitre and charcoal, two sorts, and from Lahore.

Magnesia, carbonate of, from Bellary, Salem, and Oopalon.

Salt, from Nepal.

Salt from Nowpadah pans—from Vizagapatam.

Salt produced by periodical inundation of sea over a sandy plain, collected into heaps after evaporation—from Coombaconum.

Bootan rock salt.

Alum, and earth from which it is extracted, from Cutch. This earth is chiefly found near the town of Murr. About one-sixth of the alum manufactured is used for home consumption, and the remainder is exported to Marwar, Bombay, &c.

Mode of manufacturing alum in Cutch:—"The shale from which alum is obtained forms beds in the variegated marl, and in a kind of blue clay. Long galleries are cut for the purpose of extracting it; but so plentiful is the supply, that no means are taken to support them, and they generally fall in during the rainy season. The manner in which the alum is prepared is very simple: the earth is exposed in heaps to the sun and air for about five months, during which it burns spontaneously. It is next laid out in little beds, similar to those of a field prepared for irrigation, and it is watered by a small stream for ten or fifteen days, by which time the aluminous matter accumulates into semi-crystalline plates. This substance is boiled in water for about seven hours, after which, a third or one-half, by weight, of potash is added, and it is again boiled for a few hours, according to the strength of the ley. It is then poured into a large open vessel, where, after settling for some time, it is washed, and the liquid drawn off, leaving an impure crystalline sediment. This is once more boiled, and when it arrives at a proper state, which is learned by practice, it is poured into large earthen vessels with small mouths, and sunk into the ground to prevent their breaking. After a time the vessels are dug out, broken to pieces, and a lump of pure alum extracted. Six or eight measures, by weight, of alum are produced from ten measures of the substance from the irrigating beds, and four or five measures of potash."—*Capt. Grant's Geology of Cutch*, p. 295.

"One pound of alum is manufactured at Murr for about  $\frac{1}{3}$  of a farthing, and transported to Bombay at an expense of about  $\frac{1}{5}$  of a farthing, so that whatever alum fetches in the Bombay market beyond the above, amounting to rather more than two farthings a pound, remains as a profit to the merchant and the state.

"Cutch alum sells for a considerably higher price than China alum.

"Alum and iron are only manufactured in the cold season, so that illustrations of the process of manufacture could not be procured."

Steatite black and white, from Arracan.

Marble slabs from Bellary; bricks made of white clay; marble mortar, rough—from the Ceded Districts.

Honestone from Toongabudra River, from Kurnool. Lithographic stones, from Kurnool, Juggiappettah, and Datchapilly.

Rough and polished graphite; red and yellow ochre; potstone and mica, from Bengal.

Koorun or Corundum, from Salem and Malabar.

Talc, from Nepal.

Yellow ochre, from Malacca.

Limestone, from Hooz Mines, Arrakan.

Kunkur, from Hoogly.

Limestone, from Mirzapore and Silhet.

Kunkur and limestone, from Bengal.

Building stones from Cutch. These are principally calcareous.

Polished stones from Cutch. These are specimens of the different limestone formations in Cutch.

Stones of different kinds, potter's clays and earths, &c. from Nepal.

Marbles of Gooty, from Bellary.

Serpentine.

A plate of stone-like jasper, three of agate, two of green marble; two cups of jasper agate, two of brecciated agate; two pestles and mortars, and two of jasper agate; six squares of the above, three stones, and three rough blocks—from Jesselmere.

Primitive marble; serpentine; primitive limestone; red and yellow jasper; puddingstone; jasper; brown jasper; plastic, yellow, and slate-coloured clays; white kaolin earth; soapstone for stills; Kaksning garnets in serpentine, used for making pots and pans; and two bottles of Mehanet oil—from Assam.—Major Hannay.

Pipe-clay, yellow ochre, and clay, from Singapore.

Clay, from alluvial soil, from River Hooghly.

Limestone; tremenheerite; alabaster; petroleum; agate, cornelian, and calcedony; Ava gem sand—from Tennesserim Province.

Fossil trees, from Nerbudda.

Fossil woods, from Assam.

Petrifactions and petrified woods, from Bengal and Mirzapore.

#### *Mineral Substances from Madras.*

- 1 White kaolin, from Ahloor, near Salem.
- 2 Magnesian kaolin, from hills near Vellore.
- 3 Kaolin, or porcelain earth, from Bangalore.
- 4 Magnesian kaolin, from Chingleput.
- 5 Kaolin, or porcelain earth, from Cuddapah.
- 6 Talcose kaolin, from Bimlipatam.
- 7 Kaolin, or porcelain earth, from Chittoor.
- 8 Fine white kaolin, from Travancore.
- 9 Kaolin, or porcelain earth, from Dindigal Hills.
- 10 Felspathic kaolin, from Trivatoor and Chingleput.
- 11—13 White kaolin, from Vellore or Arnee, Madras, and Chittoor.
- 14 Kaolin, from Salem.
- 15, 16 White kaolin, from Madura and Chicacole.
- 17 Kaolin, from Salem.
- 18 Magnesian kaolin, from Bellary.
- 19 Cream-coloured kaolin, from Atoor, near Salem.
- 20 Felspathic kaolin, from Tripathy Hills.
- 21 Cream-coloured kaolin, from Neilgherries.
- 22 White kaolin, composed of decayed felspar and soapstone, from Salem.
- 23, 24 Dirty yellowish and silicious kaolin, from Chingleput.

(Specimens of the rock of the hill above.)

- 25 Silicious kaolin, from Little Mount, Madras.
- 26 Pink kaolin, from Neilgherries.
- 27 Fawn-coloured kaolin, from Salem.
- 28 Red kaolin, from Salem.
- 29 Puce-coloured kaolin, from Bangalore.
- 30 Greenish yellow kaolin, from Bangalore.
- 31—35 Shale, a true fire clay, from Streepermatoor, Trepassoor, Chingleput, Mettopollium, and Cuddapah.
- 36 Rock crystal, from Tanjore.
- 37, 38 Rose and milk quartz, from Arcot.
- 39 Smoky quartz, from Nellore.

- 40, 41 Common quartz and hyalite, from Chingleput.  
 42 Amethystine quartz, from Vizagapatam.  
 43 Common thick fibrous amethyst, from Chingleput.  
 44 Flint, from Vizianagrum.  
 45 Magnesite, a pure carbonate of magnesia, from Nungungode.  
 46 Silicious magnesite, from Trichinopoly.  
 47 Soapstone, from Salem.  
 48 White and pink soapstone, from Ganjam.  
 49 Grey soapstone, or steatite, from Chittore.  
 50 Potstone, or lapis ollaris, with a pot cut of potstone, from Cuddapah.  
 51 Sulphate of baryta, or heavy spar, from Kurnool.  
 52 Corundum, from Gopaul Chettyppollum, near west of Salem.  
 53 Adularia, from near Chingleput.  
 54 Pink and white felspar, from near Arcot.  
 55 Pegmatite, from Arcot.  
 56, 57 Zeolite and Indianite, from near Chingleput.  
 58 Adularia, from near Arcot.  
 59 White felspar, from Bamlipatam.  
 60 Felspar, from Chingleput and Salem.  
 61 Glossy felspar, near Arcot.  
 62 Varieties of felspar, from Naggerly Hills, Madras.  
 63 Cleavelandite, from Coimbatore.  
 64 Pink felspar, from Chingleput.  
 65 Grey felspar, from Arcot.  
 66 Granular pink felspar, from Vizianagrum.  
 67 Common granular felspar, from Chingleput.  
 68 Fluuate of lime, from Madura.  
 69 Satin spar, from Ceded Districts.  
 70 Cube spar, from near Salem.  
 71 Calcareous spar, from Ceded Districts.  
 72 Fibrous gypsum, very pure, from Bangalore.  
 73 Fibrous gypsum and varieties of sulphate of lime, from Kurnool.  
 74 Selenite, or glossy gypsum, from Trichinopoly.  
 75 Talc and mica, from Salem and Vizagapatam.  
 76 Hornstone, or chert, from Cuddapah.  
 77 Black chert, from Tarputty.  
 78 White quartz (occurs in blocks of enormous size), from Chingleput.  
 79 Iron flint and grey nummulite, from Chingleput.  
 80 Flinty slate, from Kistnah, below Rachore.  
 81 Pipe-clay, white, from Neigherry.  
 82 Grey ball clay, from Poonamallee.  
 83, 84 White ball clay, from Chicacole and Huttnoor.  
 85 Blue ball clay, from Cuddalore.  
 86 Grey ball clay, from Poonamallee.  
 87 Yellow ball clay, from Streepermatoor and Red Hills.  
 88 Grey salt glaze clay, from Salem.  
 89 Light spongy clay, from Chingleput.  
 90 Yellow magnesian clay, from Red Hills, Madras.  
 91 Tough yellow clay, from Chingleput.  
 92 Yellow magnesian clay, from Poonamallee.  
 93, 94 Grey magnesian and tough grey clays, from Streepermatoor.  
 95, 96 Grey and yellow clays, from Salem.  
 97 Puce-coloured clay, from Cuddapah.  
 98 Lavender-coloured clay, from Bellary.  
 99 Red magnesian clay, from Red Hills, Madras.  
 100, 101 Tough brown and dark-brown clays, from Madras.  
 102 Black bituminous clay, from Rajahs Choultry, Madras.  
 103 Black clay, from Salem.  
 104 Black tank bed clay, from Chingleput.  
 105 Black clay (the matrix of the sulphate of lime), from Monegar Choultry, Madras.  
 106 Regur, or black cotton soil (yields a fine tough clay by washing), from Bellary.  
 107 Silt, from Chingleput.  
 108 Grey stony silt, from Telaveram Hill.  
 109 Green stony silt, from Streepermatoor.  
 110 Grey silt, from Cuddapah.  
 111 Yellow and red ochrey clay, from Tilaveram.  
 112 Bastard fire-clay, or shale (contains gyrogonites or fossil seeds), from Tilaveram, Streepermatoor.  
 113, 114 Yellow and orange marl, from Chingleput.  
 115 Light red marl, from Salem.  
 116 Dark red marl, from Chingleput.  
 117 Purple marl, from the Monegar Choultry, Madras.  
 118, 119 Brown and grey marl, from Chingleput.  
 120 Dark-grey magnesian marl, from Red Hills, Madras.  
 121 Greenish-white marl, from Chingleput and Wallabad.  
 122, 123 Greenish-yellow earth and friable lithomarge, from Bangalore.  
 124 Indurated lithomarge, from Cuddalore.  
 125 Rock crystal, from Toombodra.  
 126 Smoky quartz, from Tanjore.  
 127 Agate and calcedony, from Rajahmundry.  
 128 White quartz, from Tilaveram Hills, Madras.  
 129 White stone, or albite, from Pellaur River.  
 130 Hyalite, from Nellore.  
 131 White sand, from Madras.  
 132 Variety of ice spar, from Salem.  
 133, 134 Glassy felspar and pegmatite, from Arcot.  
 135 Green stone, from Tilaveram Hills.  
 136 Venetian talc, from Salem.  
 137 Common salt, from Masulipatam.  
 138 Refined salt, from Nellore.  
 139 Magnesia, or magnesite, from Salem and Trichinopoly.  
 140 Epsom salts (prepared from the Salem magnesite, by Dr. Lima), from Port Novo.  
 141 Saltpetre, from Errode and Salem.  
 142 Purified saltpetre, from Gunpowder Manufactory, Madras.  
 143 Carbonate of potash, from Madras.  
 144 Purified carbonate of soda prepared from Dhoby's (Washerman's) earth from Madras.  
 145 Alum, from Vizianagrum.  
 146 Baryta, from Cuddapah.  
 147 Bichromate of potash (prepared from chromate of iron), from Port Novo.  
 148 Prepared lime (from the shells on the beach), from Madras.  
 149, 150 Greyish-white and yellowish-white marbles (granular), from Cuddapah.  
 151 Yellow marble, from Gooty Hills.  
 152—155 Green, pink, grey, and lavender-coloured marbles, from Cuddapah.  
 156—158 Purplish-coloured, wax-coloured, and bluish-grey marbles, from Ceded Districts.  
 159 Grey and yellow marble, from Rylcherro, near Cuddapah.  
 160 Black marble, from Tarputty.  
 161 Grey lithographic marble, from Datchapilly.  
 162 Grey lithographic marble, from Cuddapah.  
 163, 164 Yellowish-grey lithographic marble, from Kurnool and Juggiahpett.  
 165, 166 Dolomite, or magnesian limestone, from Travancore and Rajahmundry.  
 167 Calcareous limestone (from the vicinity of the fossil shell lime), from Trichinopoly.  
 168 Porphyritic dolomite (occurs under the yellowish limestone), from Cuddapah.  
 169 White and grey nodular limestone, from Chingleput.  
 170 Kunkur, a variety of nodular limestone, from Cuddapah.  
 171 Septaria, or hydraulic cement stones, from Chingleput.  
 172 Shells, from the beach, Madras.  
 173 White granite, without mica, from Arcot.  
 174 Compact white granite or pegmatite; the same, converted artificially into kaolin by steeping in lime-water; from Chingleput.  
 175—177 White granite, green and pink granite, and labradorite, or variegated felspar, from Chingleput.  
 178 Porphyritic pink granite, containing small crystals of tourmaline, from Seringapatam.

- 179 Flesh-coloured granite, from Chingleput.  
 180 Syenite, from Arcot.  
 181, 182 Pink granite and syenite, from Bangalore.  
 183 Grey granite, from Cuddapah.  
 184 Bright red granite, from Bangalore.  
 185 Pinkish granite, from Bellary.  
 186 Mica schist, from Cuddapah.  
 187 Mica schist (occurs with plumbago), from Bimlipatam.  
 188 Porphyritic granite, from Chingleput.  
 189 Porphyry (composed of basalt and quartz), from Bangalore.  
 190 Porphyry (composed of silicious limestone and large crystals of felspar), from Cuddapah.  
 191 Porphyry (composed of silicious paste, embedding fragments of jasper, quartz, and felspar), from Allumpilly.  
 192 Porphyritic conglomerate, from Cuddapah.  
 193 Silicious eurite, a variety of greenstone, from Bangalore.  
 194, 195 Greenstone, from Tilaveram Hills and Nellore.  
 196 Hornblende, from Hoonsoor.  
 197 Hornblende schist, from Bangalore.  
 198 Basaltic hornblende, from Arcot.  
 199 Basalt, from Dunnel.  
 200 Black slaty limestone, from Cuddapah.  
 201 Serpentine and serpentine porphyry, from Bangalore.  
 202 Spongy clay ironstone, from Red Hills.  
 203 Slate for roofing or building, from Kalidgee.  
 204, 205, 206 Building slate; slate, containing large grains of iron pyrites; and roofing slate, from Cuddapah.  
 207 Polishing slate, from the Ceded Districts.  
 208 Slaty marble, from the Tumbbovdra.  
 209 Whetstone, from Kistnah River.  
 210 Grey whetstone, from Nellore.  
 211 Yellow whetstone, marked, No. 67, from Cuddapah.  
 212 Grey flinty slate, from Tilaveram Hills.  
 213 Grey soft aluminous whetstone, from Bunkrapett.  
 214 Aluminous slate, from Cuddapah.  
 215 Sandstone, from South Arcot.  
 216, 217 Sandstone or freestone, from Nellore and Kencattagherry.  
 218 Sandstone, from Nellore.  
 219 Aluminous shale, yields sulphate of alumina, from Chingleput.  
 220 Sandstone, embedding gyrogonites, from Streepermatoor.  
 221 Compact aluminous shale, from Nuttum Hill, Chingleput.  
 222 Claystone, from a bed of marl, from Chingleput.  
 223 Diamond breccia, from Allumpilly.  
 224 Hyacinth, from Nuttum Hill, Chingleput.  
 225, 226 White and blue sapphires, from Kangagum, Coimbatore.  
 227 Lepidolite, from Cuddapah.  
 228 Clevelandite, or precious felspar, from Chingleput.  
 229 Clevelandite, from Vizagapatam.  
 230, 231 Emery and corundum, from Gopaulchetty Pollium.  
 232—234 Red, blue, and green corundum, from Shalashelai-rainy and Salem.  
 235 Beryl, or aquamarine, from Kangayum, Coimbatore.  
 236 Schorl, from Gopaulchetty Pollium.  
 237 Tourmaline, from Salem.  
 238 Precious garnet, from Condapilly.  
 239 Common garnet, from Bangalore.  
 240 Amethyst, from Hydrabad.  
 241 Agate, from Rajahmundry.  
 242 Cat's-eye, from Kistnah River, Rachore.  
 243, 244 Jasper porphyry and jasper, from the Ceded Districts.  
 245 Rock crystal, from Naggery Hills, Madras.  
 246 Common opal, from Kistnah.  
 247 Calcedony, from Rajahmundry.  
 248 Cornelian, from Godavery.  
 249 Onyx, from Kistnah.  
 250 Bloodstone, from Salem.  
 251 Wood opal, from Madura.  
 252 Petrosilex, or petrified wood, from South Arcot.  
 253 Sandstone coloured by gold, from the Western Ghaut.  
 254—256 Menacranite, or oxide of titanium; oxide of titanium, with micaceous ore; and variegated copper ore, very rich in metal, from the Neilgherry Hills.  
 257, 258 Grey and green copper ore, rich in the metal; and liver-coloured copper, from Guntoor.  
 259 Dark red copper, from Tadah Talooch, Guntoor.  
 260 Compact copper-glance and grey copper ore, from Copper Mountain, Bellary.  
 261 Malachite and purple copper ore, poor in metal, from Nellore.  
 262 Black, green, and grey copper, from Naggapat Talook, Nellore.  
 263 Fibrous grey manganese ore and dendrites, from Mahratta country.  
 264 Black clay, containing black oxide of manganese, from Neilgherry.  
 265 Umber, or brown oxide of manganese and iron, from Neilgherry.  
 266 Native antimony, and grey antimony ore, from Vizianagram.  
 267, 268 Radiated grey antimony ore, or sulphuret of antimony; and galena, or lead-glance, from Kurnool.  
 269 Galena, or sulphuret of lead; occurs in beds of limestone and sulphate of baryta, from Cuddapah.  
 270 Chromate of iron, from South Arcot.  
 271 Chromate of iron, from Salem.  
 272 Cube-ore, or arseniate of iron, from Guntoor.  
 273 Terrestrial native iron, highly magnetic, from Salem.  
 274, 275 Common iron pyrites; and hepatic iron ore, or liver pyrites, from Cuddapah.  
 276 Common magnetic ironstone, from Chingleput.  
 277 Iron sand, or arenaceous magnetic ironstone, from Calicut.  
 278 Iron sand, from Madras.  
 279 Earthy magnetic ironstone, from Chingleput.  
 280, 281 Specular iron ore, or iron-glance; and scaly red iron ore, or red iron tooth, from Vizagapatam.  
 282 Ochry red ironstone, or red ochre, from Chingleput.  
 283 Common red ironstone, from Cuddapah.  
 284 Red hæmatite, from Vizianagram.  
 285 Red hæmatite, or fibrous red ironstone, from Chingleput.  
 286, 287 Compact brown ironstone; and brown hæmatite, or fibrous brown ironstone, from Red Hills, Madras.  
 288, 289 Compact black ironstone, from Chingleput and Salem.  
 290 Black hæmatite, from Tilaveram Hills.  
 291 Sparry ironstone, from Kurnool and Cuddapah.  
 292 Jaspersy clay ironstone, from Soondoor.  
 293 Common clay ironstone, from Red Hills.  
 293a Laterite, from Madras.  
 294 Reniform, or kidney-shaped clay ironstone, from Red Hills, Madras.  
 295 Meadow ore, or conchoidal bog iron ore, from Tilaveram and Vizagapatam.  
 296 Vesicular iron ore, from Bangalore, Chingleput, Nellore, and Salem.  
 297 Vesicular iron ore, from North Arcot.  
 298, 299 Black band iron, from Soondoor, Salem, and Chingleput.  
 300 Iron ore, from Kurnool.  
 301 Purple oxide of iron, Cuddapah.  
 302 Octohedral crystals of peroxide of iron, from Salem.  
 303 Silvery white kaolin, from Bimlipatam.  
 304 Cream-coloured ochre, from Salem.  
 305 Warm stone-coloured ochre, from Chingleput.  
 306 Pure stone-coloured ochre, from Bangalore.  
 307 Flesh-stone coloured ochre, from Salem.

- 308 Dark shade of grey ochre, from Nuttum.  
 309 White ochre, or porcelain earth, from Bangalore.  
 310 Pale yellow ochre, from Nuttum Hill.  
 311 Deep yellow ochre, common in the bazaar at Madras.  
 312, 313 Orange ochre, made from the yellow ochre by heat, and bright yellow ochre, from Cuddapah.  
 314 Roman ochre, from Chingleput.  
 315 Lavender-coloured ochre, from Bangalore.  
 316 Brown-coloured ochre, from Chingleput.  
 317 Salmon-coloured ochre, from Salem.  
 318 Venetian red, from Madras.  
 319 Light red ochre, prepared from the yellow ochre, from Nuttum Hill.  
 320 Antwerp red, from Ganjam.  
 321, 322 Indian red and purple ochre, from Chingleput.  
 323, 324 Raw and dark umber, from Neilgherry.  
 325, 326 Raw and burnt sienna, from Salem.  
 327 Cologne brown, from Neilgherry.  
 328 Peroxide of manganese, from Mahratta country.  
 329 Plumbago, or black lead, from Vizianagrum.  
 330 Iron sand, from Bimbilipatam.  
 331 Ultramarine, prepared from the lapis lazuli, from Bombay.  
 332 Alumine, coloured with madder; lake, prepared from the munjathe, or madder, from Chingleput.

## CLASS II.

## CHEMICAL AND PHARMACEUTICAL PROCESSES AND PRODUCTS.

[Though the Arabs usually obtain credit for having given origin to chemistry, there is every probability that the Hindoos were acquainted with all the substances and preparations which are mentioned in the work of Geber, the earliest Arabian chemist. The chemical substances enumerated by him are all met with in India: some of the names by which they are designated seem to be derived from the names of the same substances in India, as *sajimen*, from *sajji noon*, signifying soda salt. The acids, also, which the Arabs prepared, the Hindoos have processes for making and still continue to make, by methods as simple and with an apparatus as rude as in the most ancient times. The Arabs, moreover, have been proved to have been acquainted with, as they have quoted from, the most ancient Hindoo works on medicine, in which most of these chemical substances are mentioned. In the present day, however, the chemical products of the East are not of a nature to bear favourable comparison with those of the West. Few, therefore, of such have been sent for exhibition, and those only which are employed in medicine; while others have been prepared in the East India Company's dispensary in Calcutta, with the aid, of course, of European superintendence: of these the specimens of sulphate of magnesia are interesting, as made from the magnesite or natural carbonate of magnesia of the Peninsula. The hydrochlorate of ammonia is obtained in considerable quantities from brick-kilns in which animal manure is used as a fuel.

Among the medicinal substances obtained from the vegetable kingdom, several are already well known in Europe. The senna and the colocynth may be noticed as good in quality and coming from new sources. What is commonly called India senna is the growth either of Arabia or of the east coast of Africa, being first imported into Bombay and thence sent to this country. The seeds of *Ipomea cærulea* and the roots of *Convolvulus turpethum* are interesting as belonging to the same natural family as the jalap and scammony, and both used, as these are, as purgatives. The seeds of the *Ipomea cærulea* are, probably, the *hub-al-nil*, or *granum nil*, of the Arabs.

They are much esteemed in India, as being quick and yet mild in their action. The gamboge of *Garcinia tinctoria*, collected by Dr. Hugh Cleghorn, was first discovered many years ago. Dr. Christison has lately shown that both as a pigment and as a purgative it is very effective. It may be obtained in considerable quantities in the forests of Mysore and of Malabar.

The chiretta (*Agathotes chirayita*), of the family of Gentians, as a bitter tonic, is highly esteemed in all parts of the Bengal Presidency, especially in the form of cold infusion, as the kroat or creyat (*Justicia paniculata*) is in the Peninsula of India. This became celebrated as the basis of the *Droque amere*.

The oil of *Celastrus nutans* was exhibited by the late Dr. Malcolmson in the treatment of beriberi. The *Hemidasmus* is valued as an efficient substitute for sarsaparilla. The *Calotropis gigantea*, and another species, *C. Hamiltonii*, may be employed as substitutes for ipecacuanha, and are esteemed as alteratives in many skin diseases. Of the animal substances, the blistering beetle (*Mylabris cichovei*) employed in India is interesting as belonging to the same genus as that described by Dioscorides.

Several other medicinal substances, or which may be used as such, may be found among the spices and intoxicating drugs, gums, resins, and oils, and among astringents. Most of the medicines known in India may be seen in—

*The Collection of Mineral, Vegetable, and Animal Substances useful in Medicine and the Arts, collected in the Bazaars of India, by J. FORBES ROYLE, M.D. See the list at the end of Class IV.*

Specimens of Aconitina, obtained by two processes from the roots of *Aconitum ferox*, imported from the Himalayas, are interesting, as difficulties have been experienced in obtaining the alkali. They are exhibited by Mr. W. Headland, of King's College.]

## MEDICINAL SUBSTANCES.

*From the Bengal Presidency.*

Borax, refined; Acid, nitric; Acid, benzoic.  
 Arsenious acid; Realgar; Orpiment; Mineral carbonate of soda; Sulphate of soda; Saltpetre; Sulphate of copper; Carbonate of lead; Litharge; Minium; Cinnabar; Corrosive sublimate; Magnesite; Magnesiæ sulphas; Hydrochlorate of ammonia.

Cannabis, Ind. ext. and tinct.; Nux vomica; Nux vomica bark; Aconitum ferox; Aconitum tincture; Castor-oil seeds; Cassia fistula; Senna leaves; Gamboge; Ipomea cærulea; Cheretia; Cheretia extract and tincture; Colocynth; Colocynth extract; Catechu; Assafœtida; Calotropis gigantea; Calotropis powdered; Hemidesmus indicus (Anantamool).

Mylabris (Meloe) trianthemæ (Native blisterfly)—From E. I. Company's Dispensary, Calcutta.

Hill honey; Gall nuts; Oil of cubeb and croton; Mustard oil; Grass oil; Gurjun oil; Medicinal opium; Morphia; M. Hydrochloras et Acetas; Hyoseyami, fol.; Hyoseyami extract, et tinctura; Stramonii sem.; Cannabis indica; Malkungnee, or Celastrus nutans; Myrica sapida (bark of the); Anuntamool, or substitute for sarsaparilla; Momordica, sp.; Mishmee bitter or Mishmee tita, Coptis teeta.—E. I. Company's Dispensary, Calcutta.

Jabrang, fruit of (*Xanthoxylum*), used in medicine; Nux vomica—from Assam.

Gmelina arborea; Echites antidysenterica; Menispermum cordifolium; Cyperus munga; Helicteres isora; Sphæranthus, sp. moondee; Cheretia (*Agathotes chirayita*); Xanthoxyli, sp. Budrunga Tej-baul; Rheum emodi; Fætidea Mauritiana?; Pongamia arborea; Swietenia febrifuga; Althea, sp. Khutmee; Serratulæ, sp. Kasnee; Semecarpus anacardium; Gardenia duneto-

rum; *Fumaria officinalis*; *Adiantum cordatum*; *Barringtonia acutangula*; *Cordia grandiflora*; *Momordica muricata*; *Embelia robusta*; *Linaria* sp. *Sterculia ramosa*; *Asparagus officinalis*; *Cassia fistula*; *Cucumis*, sp. *Kuchree*; *Plumbago zeylanica*; *Cæsalpinia Bonducella*; *Tribulus lanuginosus*; *Argemone mexicana*: *Sarsaparilla*, substitute for; *Anuntamool*, from Patna; *Punica granatum*, rind of the fruit and bark of the root; *Tejraj*, *Bajraj*, *Kamraj*, *Doobraj*, and *Madhoooraj*, from *Bhagulpore*; *Yew leaves*, marked *Podocarpus nana*; *Acorus calamus*, oil of *Cubebs*; *Choulmoogra odorata*, *Choulmoogra*; oil of *Croton*; *Camphor* from *Borneo*; *Cubebs*; *Cheena kuwab*; *Piper cubeba*, sent from *Calcutta*.

The following medicinal substances, used by the natives of Arrakan, are communicated with their local names and supposed properties. They are nearly all said to be of common occurrence throughout Bengal:—

*Guararan*, a carminative; *Shuedelai*, a powder for sores; *Danzagoophroo*, tonic alterative; *Gnapoongtsay*, a carminative; *Mahaga*, drastic purgative; *Toungyen Khat*, astringent; *Thamaga*, carminative and tonic; *Thetyeng*, tonic, aperient; *Thabeyah*, carminative; *Kamaungkha*, refrigerant; *Kankyautner*, tonic aperient; *Let-topkyee*, astringent; *Nwashieagyer*, sedative; *Kokkho*, tonic aperient; *Hting*, tonic; *Pwabet*, expectorant; *Thesyenggyee*, warm purgative; *Thaweng poukphyee*, expectorant; *Teermakhan*, tonic; *Tabwot*, a carminative; *Maor*, refrigerant; *Oayet*, refrigerant; *Touksha*, carminative; *Oabathaga*, aperient; *Toushouk*, tonic; *Kyoapmyet*, febrifuge; *Nanloogyng*, tonic aperient; *Tsengthamanway*, laxative; *Pouknet*, tonic and carminative; *Tabatsay*, febrifuge; *Karawee*, tonic; *Thanly etgnai*, laxative; *Wow-oo*, febrifuge.

Java medicines, a series of, forwarded from Singapore.

#### From Bombay.

*Oondee oil* (Tanna). *Calophyllum inophyllum*, oil expressed from the nut, used as a stimulant externally and internally. Imported from Somali coast.

*Kurunj oil* (Tanna). *Pongamia glabra*, oil expressed from nut; used externally as a stimulant.

*Senna leaves*. Now grown in quantities in the Dekkan for the supply of Government stores; but no demand elsewhere. Four consignments have been sent to England. The first afforded a remittance about 2s. 2d. per rupee; of the second and third no accounts have yet been received; the fourth was sent last month (December 1850), its price as at present bought from the Ryots is 9 lbs. per rupee, being 2½d. per pound, or thereabouts.

#### From Madras.

*Calabunda* (*Aloe perfoliata*)—from *Vizagapatam*.

*Gamboge*—from *Canara*; ditto collected by *Dr. Cleg-horn*, from *Madras*.

*Hemidesmus indicus*; *Convolvulus turpethum*, root and powder; *Clitoria ternatea* seed and powder; *Cannabis indica* (flower's tops).—*Professor Key*, from *Madras*.

Specimens of *Mylabris cichorei*; *Pulvis mylabris cichorei*; *Tinctura cannabis sativæ*; *Hoya viridiflora* (*Aselepias vomitoria*); *Hymenodictyon utile*; *Soymida febrifuga*; *Dry bark of the mullay or jungle margosa*; *Dry bark of the vapum or margosa tree*; *Croton seeds*.

*Napaula oil* (*Croton tiglium*)—from *Vizagapatam* and *Ganjam*.

*Justicia paniculatan creyat*. Specimens of salt—from *Nellore*.

### CLASS III.

#### AGRICULTURAL PRODUCE.

[From the latitude and general climate of the different parts of India, it would naturally be inferred that the agricultural products must differ very considerably in the widely-separated provinces, and that they must certainly be entirely different from those of Europe, especially as the natives of the country are usually stated to live chiefly upon rice. This is a fallacy which has no doubt

originated from Europeans having obtained their principal information respecting India from its southern provinces. It would not, perhaps, be too much to say that probably the number of those who seldom taste rice far exceeds those who live upon it. For, in fact, the culture of wheat and barley, and of common millet, constitute the agriculture of many parts of the country quite as much as rice, sugar-cane, and other millets. This is in consequence of the seasons of cultivation being very different, one set of the cereal grains being sown in autumn, and grown during what constitutes the winter of Europe, while the other are sown in the midst of its summer. Thus wheat, barley, and common millet (*Panicum miliaceum*), are sown in October and reaped in March, while rice, maize, the great and Indian millets, are sown on the accession of the rainy season in June, and harvested in September or October.

Of wheat several varieties are grown: some of very fine quality, as the soft wheat, called *pyssee*, and the hard wheat, called *jullalya*, both exhibited from the *Nerbudda* valley. Samples of these shown a few years ago in *Mark Lane* were considered to be finer than any wheats in the market. The soft wheat, which is most valued in this country, is thought less of in India, where the natives prefer the hard wheat, and give a higher price for it, as they consider it the most nutritious. Like the hard wheats of the south of Europe, this variety is used in India for making a kind of vermicelli, and was thought to contain a large proportion of glutinous matter; but this did not appear when the two kinds were analyzed by *Professor E. Solly*. Wheat is cultivated as far south as *Burma*, from whence a brownish-coloured variety has been sent, and at considerable elevations in the *Himalayan Mountains*, where some fine kinds of barley are also grown. Oats have been introduced by the English, and are produced of fine quality in the district, and to the northward, of *Patna*.

*Indian corn* or *maize* (*Zea mays*), a native of the *New World*, is cultivated in small quantities all over India, but not as a principal crop, being chiefly eaten in a green state and after the grains have been roasted. The great millet, or *Durra*, of the Arabs, *Joar*, and *Jawaree* of India (*Sorghum vulgare*), occupies the place of *Indian corn* in Asia, where it is extensively cultivated, and forms a principal article of diet of the natives. The grains are large, and in chemical composition come near to *Indian corn*, but are apt to be attacked by the weevil. The other millets, species of *Panicum*, &c., small in size and hard, are also much used as articles of diet, and might, from their cheapness, perhaps, be profitably exported as food for the smaller animals in other countries.

But, besides the cereals, the natives of India cultivate a great variety of pulses, some of which are known in Europe as the pea, lentil, gram (*Cicer arietinum*). Others, such as varieties of *Cajanus* and of *Phaseolus*, also yield pulses which, like the cereals, are cultivated for food. These, being cooked with ghee or melted butter, give the natives the advantage of a mixed diet, instead of their subsisting, as usually stated, on a single substance like rice.

The different oil-seeds also occupy a share of the farmers' attention: of these linseed is well known in Europe, but in India is cultivated only on account of the seed-oil, and not for the flax of the plant. Also, mustard and rape, or rather other species of *Sinapis*, safflower seeds (*Carthamus tinctorius*), castor-oil plant, poppy, brown and white til or sesamum, and black til (*Guizotia oleifera*). For other oils, see OIL SERIES AND MEDICINES.

Among the roots cultivated, yams and sweet potatoes may be mentioned; also, turmeric and ginger, onions and garlic. Carrots often yield a large crop with the aid of irrigation, but the climate is not favourable for the field culture of turnips. Melons and cucumbers are also cultivated near wells, or in the beds of rivers, as also several of the fruits used as condiments, as coriander, cummin, &c.

(A.) *Cereals.*

Wheat:—Pissee, sohalya, jullalya, kutya, varieties of *Triticum sativum*, from the Valley of the Nerbudda.

Flour; three qualities, from native mills, Calcutta.

Wheat, a dark-brown variety, from Burma.

Oats (*Avena sativa*), from Patna.

Banaful rice, and some of its straw, from Hooghly.

Rice (*Oryza sativa*), and paddy, or unshelled rice, from Kêmaon.

Black and red paddy (*Oryza sativa*), from Bellary.

Varee rice and paddy, from Travancore.

Varee Nelloo, paddy, from Calicut.

Wild rice:—Junglee dhan and Cheenia dhan, from Nepal.

Table rice:—Indramayo, from Singapore.

Pulut rice, a delicacy, prized for its nutritious qualities; and a dark variety, from Malacca.

Rice, and a variety of, Ketana, from Singapore.

Rice, varieties of:—Bansmutti, Hunsraj, Raee Monea, Dalyanjan, Sookhammad, Ramkajul, Teluk, Sookhunda, Unjhuma, Dhooco, Sathee, Seorah, Herunj, Gujraj, Beitea, Anundee, Buttese, Hamoona, Kuhna, Rama-juan, Mattea, Knomoolie, Dhaw, Soonkhur, Kumera, Doodhie, Beerah, Sookhurra, Moonree, Buthka, Jhunoa, Motuchoor, Jubbedie, Jhunvan, Najar, Mahestua, Gowreea. There are two specimens of each, one shelled, the other unshelled; from Pilibeet in Rohilkund.

Rice, varieties of, from Arrakan.

Rice from Ahmedabad. This is much prized for taste and scent, and large quantities of it are annually exported to Baroda, Cambay, and elsewhere.

White, black, and glutinous red rice, from Tennasserim.

*Millets.*

Great millet or *durra* of Arabs.—Joar of India.

*Sorghum vulgare* and *saccharatum*, large and small; grown all over India.

Red, white, and brown Cholum or jawaree, from Bellary and other parts of India.

Indian corn, varieties of, from Nepal and Assam.

Indian millet, Bajree (*Penicillaria spicata*), from India, Bellary, and Cutch.

Italian millet (*Setaria italica*), from Calcutta; Koon-  
goonie (*Panicum italicum*), from Bellary; Kungnee, from  
Nepal; Kadi kane (*Panicum miliaceum*), from Madura,  
Tinnivelly, and Palamcottah; Sanwuck, *Panicum frum-*  
*taceum*, from Ghazeeppore, Meerut, and Nepal; Koda,  
*Paspalum serobiculatum*, from Nepal and Calcutta; Mun-  
dooa, Raggee (*Eleusine corocana*), from Bellary, Mirzapore,  
Meerut, and Kêmaon; Chooa (*Amaranthus farinaceus*),  
from Kêmaon; Razgeera (*Amaranthus frumentaceus*),  
from Bombay.

Surgooge grain (*Eleusine sp.*), from Hooghly.

Goorura and Tipsea, small millets, produced by wild  
Panics, from Mirzapore.

Buckwheat:—Oogul (*Fagopyrum vulgare?*), from  
Kêmaon and Nepal.

*Pulses.*

Urhur ke dhal; Dhal (*Cytisus cajan*), from Gwalior,  
Madura, and Tinnivelly; Dhol or thoravi, from Palam-  
cottah; Tor var. (*Cytisus cajan*), from Bellary; Urhur  
(*Cajanus indicus*), from Calcutta; Gram, Chuna (*Cicer*  
*arietinum*), from Bellary; Dhol Chuna, grown all over  
India; Chuna (*Cicer arietinum*), from Calcutta.

Mash (*Phaseolus mungo*), from Bellary; Mash and  
Dhol mash, grown all over India; Mash (*Phaseolus*  
*mungo*), from Nepal.

Green gram:—Moong (*Phaseolus radiatus*), from  
Bellary and Madras.

Green gram:—Moong, grown all over India.

Black gram:—Moong, variety of (*Phaseolus radiatus*),  
from Vizagapatam and Ganjam.

Black gram, grown all over India.

Muskully (*Phaseolus radiatus*), Sona moog (*Phaseolus*  
*ureus*), Kista moog (*Phaseolus*), Kalle moog (*Phaseolus*),  
Mayanea (*Phaseolus trilobus*), from Calcutta; Lall Goo-  
ronah (*Phaseolus trilobus*), from Kêmaon.

Horse gram:—Cooltic (*Dolichos uniflorus*), from Bel-  
lary; Gahut (*Dolichos uniflorus*), from Kêmaon and  
Nepal.

Red gram (*Dolichos catjang*), grown all over India.

Red and white gram (*Dolichos catjang*), from Vizaga-  
patam and Nepal; Thatapyre (*Dolichos catjang*), from  
Madura, Tinnivelly, and Palamcottah; Banzampesalec,  
Vizagapatam; Bhut (*Soja hispida*), from Kêmaon.

Peas:—Muttar (*Pisum sativum*), Goll muttur (*Pisum*  
*sativum viride*), from Calcutta and Nepal; Mussoore  
kullye (*Ervum Lens*), Soora kissurree (*Lathyrus sativus*),  
Baro Chuna (*Vicia sativa*), from Calcutta.

Katjang zavah, Katjang merah, Katjang tjee, Katjang  
zungak, Katjang batoo, pulses, from Java.

French beans, sem, from Nepal.

Green peas, or pulse, Catjang ejoo; Catjang tahoo, from  
Singapore, Sumbawn, and Sumatra.

*Roots and Oil Seeds, &c.*

Onions and onion seed, from Jessulmere.

Poppy seed, from Calcutta, Patna, &c.

Linseed, Tesee (*Linum usitatissimum*); Kisto til  
(*Sesamum orientale*)—from Calcutta.

Black til. Ram til (*Guizotia oleifera*)—from Bombay  
and Madras.

Castor oil seeds, Behrindu (*Ricinus communis*).

Mustard seeds, &c., Kala surson (*Sinapis dichotoma*);  
Shwet raee surson (*S. glauca*); Jhoone raee (*S. ramosa*)  
—from Calcutta.

Safflower and Soorj mookhee (*Helianthus annuus*).

Cucumber and melon seed, from Nepal and Bikaneer.

Oil-cake, from Nepal.

Bamboo rice, from Nepal.

Bhatwas, Goorans, Shutya, and Mishoyang, from  
Nepal.

Troopoo pinakoo, from Calicut.

(B.) *Dried Fruits and Seeds.*

[The fruits which are dried and preserved in India are  
not numerous. The tamarind is the principal, and is much  
employed in making sherbets: unripe mangos are preserved  
on account of their acidity. The ber, or byer, or jujube,  
is occasionally preserved, and baked plantains have been  
sent, but have not arrived in a good state. Figs, raisins,  
dried plums and apricots, are imported from Caubul; and  
dates from the Persian Gulf. The cocoa-nut is conspicuous  
as a seed which is valued for its kernel. Almonds and  
pistachio nuts are imported from Caubul; walnuts and  
hazel nuts from Cashmere and the Himalayas. The seed  
of Terminalia catappa is called badam or almond, and used  
as a substitute for it, as are many other oily seeds, by  
the natives of India. The dorian fruit (*Durio zibethinus*)  
may be considered rather as a curiosity: it is highly  
esteemed as a fruit in the Eastern Islands, notwith-  
standing its disagreeable odour. The preserved bel fruit  
(*Ægle marmelos*) is valued, as a medicine, for its mild  
subastringent properties. What is called *Muoha* fruit is  
only the flowers dried as they fall off. They abound in sac-  
charine matter, and are eaten by the natives; and are also  
subjected to fermentation, when they yield a spirit which  
forms the common arrack of a great part of the country.  
Its flavour is compared by some to that of whiskey. The  
seeds yield a valuable oil which becomes solid in this  
climate. See OIL SERIES.]

Mangifera Indica, amchow; unripe mangos.  
Tamarinds (*Tamarindus indica*), from Calcutta and Java.

Dried byer (*Zizyphus jujuba*), from Bengal.  
Muhooa fruit (*Bassia latifolia*), from Moorshedabad.  
Cocoa-nut (*Cocos nucifera*).

Kanari nut (*Canarium commune*), from Java.

Dessy-a kroot (*Aleurites triloba*). The specimens forwarded are all that could be procured at the time they were ordered; they were obtained from Belgaum, where, in this Presidency, they chiefly grow. The Central Committee of Calcutta requested that this article might be sent from the Bombay Presidency. These are called Belgaum, or country walnuts. The nuts are so called from their resemblance to walnuts: the kernels taste like them, and yield a large portion of pure palatable oil.—*Bombay Report*.

(C.) *Substances used in the preparation of Drinks.*

[Tea is so peculiarly a Chinese product as to be almost a synonym of the country. From the difficulties at first experienced in producing good teas in Penang, Java, and Rio Janeiro, it was inferred that the soil and climate required for the tea plant were of so peculiar a nature as to render it difficult, if not impossible, to produce good tea anywhere out of China. This was no doubt owing in part to its having been supposed that the plant was one which required a hot climate. Careful comparison of the information which was then within reach made it probable that the plant or plants were natives of temperate climates. The author of this note gave it as his opinion, in the year 1827, that the Chinese tea plant or plants might be successfully cultivated in the Himalayan Mountains; and in an essay on the subject in his "Illustrations of Himalayan Botany," in 1834, entered into the details of facts, and his reasoning from them. The Indian Government having at this time determined to attempt the cultivation of tea in any suitable locality in these mountains, a plant was discovered in Assam, of which the leaves were there manufactured into tea, and which was supposed to be either the true, or a variety of the, tea plant of China. The plant, however, flourishes in a warm moist climate, and has much larger leaves than the China plants. This discovery, however, led to the establishment by the Indian Government of farms for the growth of tea. Chinese, acquainted with the processes, were invited into Assam to take charge of the manufacture. Success having attended the measure, the whole of the establishment was transferred to the Assam Tea Company, from whom some samples have been received: others are exhibited in another part of the building. Two samples have also been sent from Chinese planters who have settled in Assam.

At the same time that the culture of the indigenous plant was established in Assam, tea seeds were obtained from China; but chiefly from the most southern tea districts, from whence there is reason to believe most of the manufacturers have also come. The tea seeds on their arrival in Calcutta were sown in tubs, and the plants afterwards sent to Assam, as well as to Dr. Falconer, who planted them in nurseries in Kêmaon and other Himalayan districts. There these Chinese tea plants grew and flourished even in situations where they were occasionally covered with snow. They flowered in the third year, and ripened their seed, from which time the culture has continued to encrease. Millions of seeds are sown annually, so as now to occupy about 1,000 acres, in different situations, from Kêmaon to the hill tracts newly acquired from the Seiks. Some uncertainty existed at one time about the methods of making the best kinds of black and of green teas. Some who had resided at Cantôn having

stated that the Chinese made either green or black tea from the same plant; others, that they could not do so without the aid of colouring matters. There is no doubt that there are at least two species of tea plant: one, called *Thea bohea* by botanists, was supposed to be chiefly employed for making black teas; the other, called *Thea viridis*, was thought equally essential for making the green teas. The Chinese tea-makers in Assam in some measure settled the question by making both kinds of tea from the same plant: and Mr. Fortune, in his visits to the tea districts on the coast of China, ascertained that the plant called *Thea viridis* was that chiefly employed in making both kinds of tea and their several varieties. The *Thea bohea* could, of course, be employed for the same purpose in districts where it is indigenous, as the great difference depends upon the manufacture and not upon the plant. The processes have been fully explained in Mr. Ball's work on the Manufacture of Tea in China. They consist, in the preparation of *black tea*, in carefully-watched and regulated processes of *spontaneous heating, or slow fermentation*, of the leaves, until a certain degree of fragrance is developed. The leaves are said to *wither and give*, and become soft and flaccid. When the proper time has arrived, the leaves are removed to the roasting pan. After being roasted and rolled two or three times, they are dried in a cylinder of basket-work, which is placed over a small charcoal fire. After the drying has continued about half an hour, the leaves are turned and again submitted to the heat for another half-hour. They are then taken out, rubbed and twisted, and, after sifting away the small dust, again returned to the sieve and drying tub. The leaves now begin to assume their black colour. The fire is deadened by sprinkling some ashes over it. The operation of rolling, twisting, and sifting, is repeated once or twice until they have become quite black in colour, well twisted, and perfectly dry and crisp. They are then picked, winnowed, and further dried.

In the manufacture of *green tea*, the freshly-picked leaves are roasted in the kuo, or roasting-pan, at once, and at a high temperature; rolled and roasted again and again, assisted sometimes with a fanning operation to drive off the moisture, and always with brisk agitation until the drying is completed.

The great difference in the two processes consists in the black tea undergoing the process of fermentation, or withering, while the leaves for the green tea are roasted without undergoing any previous change. The two samples of green tea, the hyson and the gunpowder, were prepared from the same plants as the souchong, under the superintendence of Dr. Jameson, in the East India Company's tea nurseries in Kêmaon and the Deyra Doon. The quantity of tea produced is yearly increasing. Comparatively little has as yet been sent to this country, for it sells at very high prices on the spot where it is produced; and the inferior qualities, it is curious to observe, are actually carried across the British frontier, and meet the teas of China in Tibet, where the Chinese authority extends.

Mr. Warrington has called attention to the means adopted for giving a facing to tea, as purchasers were not satisfied with the natural dull, yellowish-green colour of tea. The Chinese, therefore, apply Prussian blue, turmeric, and fibrous gypsum to give it a bluish-green colour.

Mr. W. has lately called attention to a new adulteration, in which tea-dust is held together by gum, and faced with Prussian blue, turmeric, and a large proportion of

fibrous gypsum; the black tea being faced with earthy graphite or black-lead. So great is the adulteration that, though genuine teas give only about 5 to 6 per cent. of ash, the *lie* gunpowder yielded 34 and 45·5 per cent. of ash; scented caper 5·5, but *lie* flower caper 22·5; and mixtures, containing these lies, from 11 to 22·5 per cent. of ash.

Coffee has, like tea, begun to be cultivated in British India. It is chiefly grown, however, along the mountains of the Malabar coast, as in Wynaad, and in the Sheravoy Hills, near Salem. Some of fine quality has also been sent from Chota Nagpore, and the south-west frontier of Bengal. We have also some coffee from Assam.]

Green, gunpowder, and black teas, from E.I. Company's tea plantations in the Himalayan mountains in Kémaon and Deyra Doon.

Hyson teas; grey, black, and orange-flowered pekoe; Souchong, Mongpo, from Assam Tea Company.

Souchong tea and orange Pekoe, from Chinese in Assam.

Pekoe and Congou teas, grown on Government plantations, from Java.

Coffee, from Assam and from the South-west Frontier.

Coffee, from Calicut, and from Captain Morris.

Coffee (*Coffea arabica*), from Timmivelly.

Coffee, from Sheravoy Hills, near Salem.

Coffee berry, and in husk, from Aden.

Coffee, from Java and Borneo.

Coffee from Mr. Glasson's plantation, from Wynaad.

#### (D.) *Stimulating and Intoxicating Drugs.*

[This group includes, in the Indian collection, opium, hemp, tobacco, and a distilled spirit from an unusual source. Opium, as required for medical use and European consumption, is produced chiefly in Asia Minor, and is commonly known by the name of Turkey opium; but India produces large quantities—a portion for its own home consumption, but the great mass for export to China. The whole process of culture is displayed in a series of drawings, and all the apparatus employed in the preparation, that is, in the collection, mixing, and drying, of the drug, in the opium agency at Patna, is exhibited, together with the opium made up into balls, and covered with the petals of the poppy stuck together with the fluid part of the opium. Though this culture is a government monopoly in the Gangetic province, it is also extensively cultivated in the states of the native princes in Rajpootana and Malwa, from whence several specimens have been sent. Opium is produced of excellent quality in the Himalayas, where the tears, as collected, are simply pressed together and dried, as is the case with Turkey opium.

The hemp plant (*Cannabis sativa*), known in Europe for yielding strong fibre for ropes and canvas, is valuable in the East for its intoxicating properties. The plant is identical with that of Europe, and is the *Kinnub* of the Arabs, whence the name *Cannabis*. It is also known by the name *Husheesh*, and has a number of poetical names assigned to it, as "cementer of friendship," "exciter of desire," &c., and is supposed by some to have been the *Nepenthes* of Homer. The whole plant dried is employed for smoking; or, the leaves and capsules, without the stalks, rubbed to a fine powder, and mixed with conserves or with milk, &c., are taken to produce intoxication. A resinous secretion exudes from the upper parts, especially of the flowering stems, and is collected in various ways, and known by the name of *Churrus*. This is used for the same purpose. It has lately been recommended as a medicine to allay rheumatic and neuralgic pains, as well as to control muscular spasm. Hence, preparations of it

have been included among the medicines sent from Calcutta.

The spirit from an unusual source is that which is distilled from the flowers of the muohwa tree (*Bassia latifolia*). These abound in saccharine matter. They are, therefore, as they fall, collected and eaten by the natives; but, subjected to fermentation, a spirit is produced, which, being distilled, forms the common arrack of many parts of India. The flavour has been by some compared to that of whiskey. The tree is particularly valuable, on account of its seeds yielding a vegetable fat, likely to be useful in candle-making. See OIL SERIES.

Tobacco, a plant of the New World, has come to be universally cultivated in Asia, as in Europe. The plant is grown with great care in many parts of India, especially in rich soil near villages. But the natives totally neglect the curing of tobacco, upon which so much of its value depends in the European market, either for smoking or for making into cigars. This, to the natives of India, is of less consequence, as they mix the dried leaves of tobacco with coarse sugar or conserves of different kinds to smoke in their hookahs. Some excellent tobacco is, however, produced in different and very widely separated parts of India, as Sandoway in Arrakan, different parts of the Peninsula, and in Central India. It is probable that such tobacco as is acceptable in the European market might be produced in India, if equal care was bestowed on the growth and curing as well as on the packing of tobacco. — (See *Illustrations of Himalayan Botany*, pp. 282 to 289.) But there is great consumption in the country itself, both for smoking and for making cheroots, of which several specimens have been sent for exhibition from Chinsurah, in the neighbourhood of Calcutta, as well as from Salem and Trichinopoly.]

Tobacco, Ishay, from Arrakan.

Tobacco, from Gwalior, Maharajah Rao Scindia.

Tobacco, from Malwa.

Tobacco and cheroots (*Nicotiana tabacum*), from Trichinopoly, Salem, and Java.

Cheroots of sorts, from Trichinopoly.

Cigars, from Java.

Cigars: imitation Manillas and Havannahs, common Chinsurahs, imitation Havannahs, made at Chinsurah, of Sandoway tobacco, and of picked Bengal leaf at Chinsurah.

Opium, from Gwalior—Maharajah Rao Scindia.

Opium, country, Kano, from Assam.

Opium, Thallawar, twenty-five, and Jhallawar three years old, from Rajpootana.

Opium, prepared, from Rajah of Kotah.

Opium, complete series, exhibiting whole process of manufacture, from Patna.

Opium, specimens of, from Benares.

Opium (Government), from Khandeish.

Opium, as taken from the field, as seed, and as prepared for exportation, from Malwa.

Opium, from Nepal.

Cheek opium. This and the two following articles form a complete series. The bhatted as prepared for exportation to China; the cheek or raw juice; the poppy head, containing the seed and showing the mode of incision by which the opium juice is extracted—the three lines together are one day's incision; each head will show how many separate days it was available.—Bombay.

Opium, from Kandeish. The specimen sent is from the government stores at Dhoolia, in Kandeish.

Hemp, Ganja (*Cannabis sativa*), from Rajpootana; Bhungeera and seed, from Kémaon; Ganja, from Calcutta; Churus and Ganja, from Nepal.

Muohwa flowers (*Bassia latifolia*), and spirit distilled from them, from Rajpootana.



(E.) *Spices and Condiments.*

[Spices are proverbially the produce of the Spice Islands; but they are not all obtained from these islands, and, of late years, those which were peculiar are now cultivated in other situations. The true cinnamon, for which Ceylon is famed, is also now cultivated in Java and Malacca, as well as in parts of the western coast of the Indian Peninsula. What is so called from Assam is rather a kind of cassia. Cassia and cassia-buds are produced on the Malabar coast. The cassia leaves, *Malabathrum* of the ancients (*Tamala putra*), are used for the same purposes as bay leaves in Europe. Nutmegs are now cultivated of excellent quality in Penang, whence they have been sent for exhibition, as well as from Singapore and Tinnively, in the Peninsula of India. The wild nutmeg (*Myristica tomentosa*) is the produce of a different species. Attempts have been made to introduce the true nutmegs, when gathered from trees growing wild, at a lower rate of duty; that is, for the same duty which these wild nutmegs are charged, though they are very inferior, and the produce of a different species of plant. Mace, which is one of the coverings of the nutmeg, is, of course, obtainable from all places where the nutmeg is grown. Black, round, and white pepper, the produce of one plant, are, as in the earliest times, grown on the Malabar coast. The capsicum, considered by botanists to be a native of the New World, is cultivated in every part of India, and universally employed as a condiment by the natives in their curries: that grown in Nepal is considered by many to be very high flavoured. The small cardamoms, like pepper, are long-established products of the Malabar coast. The large cardamoms are produced in the forests along the foot of the Himalayas, though the plant producing them has not been clearly made out. Among the small carminatives, the *Ptychotis ajowan*, seems worthy of notice, from the fineness of its flavour. It appears to have been one of the kinds of ammi of the ancients, and nearly allied to the *Ammi copticum*. The black seeds of *Nigella sativa* continue to be used as a condiment, as in the most ancient times, being the *Melanthion* of the Greeks.

Ginger, a native of India, though extensively cultivated both on the plains and mountains of India, brings an inferior price in the English market to that from the West Indies, though it is there, probably, an introduced plant. If the Indian was more carefully cultivated and scraped, so as to become white ginger, it would, no doubt, bring a higher price; much of that from Travancore, as well as from Malabar, is of excellent quality. Turmeric, like ginger, is universally cultivated, being a common condiment in curries, and likewise used as a dye. Several varieties are grown in different parts of India.]

Cinnamon, from the Government plantations, Java, and from Malacca.

Cinnamon, or Cassia, from Assam.

Cinnamon, Darcheenae; cinnamon flowers, Darcheenae ka phool, from Nepal.

Cassia (*Cinnamomum albiflorum*), from Assam.

Nutmegs, from Penang and Tinnively.

Nutmegs, as plucked from tree and shelled, from Singapore.

Nutmegs, from Sarawak, Borneo.

Wild nutmegs, unshelled and shelled, from Ceram, Moluccas.

Mace, from Singapore, Tinnively, Penang, and Sarawak, Borneo.

Cloves, from Penang, Sarawak, Borneo, and Tinnively.

Cassia leaves, from Travancore.

Cassia leaves, Tejpat, from Nepal.

Spices, from Malacca.

Round pepper (*Piper nigrum*), from Assam.

Black pepper, from Travancore, Singapore, Sumatra, and Sarawak, Borneo.

White pepper, from Travancore, Singapore, and Sumatra.

Wild pepper, from Travancore.

Long pepper, from Assam and Java.

Peepul (*Piper longum*), from Bengal.

Cayenne pepper, from Sarawak, Borneo.

Bootan chillies (*Capsicum frutescens* and *Capsicum fastigiatum*), from Assam.

Chillies, from Bootan.

Small chillies.

Chillie pepper, Lal mirch, from Nepal; Tunboo, from Bhotan, Nepal.

Hill cardamoms, Paharie elachie, from Nepal.

Cardamoms, varieties of (*Elettaria cardamomum*), from Travancore.

Cardamoms, a kind of, from Assam.

Cardamoms (*Cardamomum medium*), from Bengal.

Coriander, Dhumea (*Coriandrum sativum*), from Assam and Nepal.

Cumin seed, Ajwain, and other carminatives (*Cuminum cyminum*, *Ptychotis ajowan*, *Anethum sowa*, *Nigella sativa*), from Bengal and E. I. Co.'s Dispensary.

Star aniseed (*Illicium anisatum*), imported into Calcutta from China.

Fennugreek, Methee, from Nepal.

Betel nuts (*Areca catechu*), from Assam.

Betel nut, Areca nut, from Travancore.

Betel nuts, from Sarawak (Borneo) and Singapore.

Mustard seed, kinds of, Race, Surson, Padshahee race, and Toree, from Nepal.

Ginger (*Zingiber officinale*), from Travancore.

Ginger, Udruk, from Nepal and Assam.

Zingiber Cassumnar, Bunada, from Bengal.

Turmeric (*Curcuma longa*), from Assam.

Turmeric (*Curcuma longa*), from Cuddapah.

Turmeric, from Java.

Turmeric, Huldi, from Nepal.

Sort of onion, Chappee, from Nepal.

Garlic, Lahson, from Nepal.

Sweet, Cashmere, camp, and cussoondie chuttnies; tap sauce; curry powder; guava jelly; pineapple marmalade; mango preserve; guava cheese—from Calcutta.

(F.) *Starch Series.*

[The name of this group will not indicate to the public all the substances included under it, as the term starch is usually applied to the preparation employed for giving stiffness to clothing of different kinds. The term is here employed to include a number of substances, often called arrow-root, obtained from various parts of plants, as the root and tubers, stem and fruits, usually in the state of white flour, insoluble in cold but easily dissolved in boiling water. For a long time the West Indian arrow-root (*Maranta arundinacea*) was considered the only good kind; but a very useful kind is yielded by a species of Cann, which is also cultivated in the West India Islands, and belongs to the same natural family. The *Maranta arundinacea* is now cultivated near Calcutta and in other parts of India. But large quantities of an excellent substitute are obtained in India from different species of *Curcuma*, all of which have not been clearly ascertained, though the arrow-root obtained from them has been sent from a variety of places. That of Travancore is known as a regular article of export; but it might be produced in large quantities from various parts of India.

An analogous substance is the sago meal obtained from the stems of different kinds of *Phœnix* and of other palm trees in India. Of this, one kind has been sent from Cuttack. The so-called sago meal is deposited in the cellular

part of the stems of the sago palm (*Arenga saccharifera*), "the pith of which is the staff of life to the inhabitants of the Moluccas"—(*Roxburgh*). Sir John Maundeville says, "In that land grow trees that bear meal, of which men make good bread." The sago palm grows extensively in Sumatra, from whence the sago flour is imported into Singapore, and then granulated into the different kinds of sago. In the form of sago cakes it constitutes the principal food of the natives of the Moluccas, especially during their sea voyages. Plantain meal, obtained from the fruit of the plantain, or banana, may be employed for the same purposes, though it is not so white-looking as arrow-root. Plantains form a large portion of the food of the negroes in the West India Islands. In Guiana the meal is used as a nutritious article of diet.

The seeds of *Nelumbium speciosum* and of *Trapa bispinosa* abound so much in starch, that it may be easily separated from them. Both are employed as articles of diet among the natives of India, and may well be arranged in the starch series.

Salep, or, as commonly called, *Salep misree*, may also be placed here, though the tubers are not exactly of the nature of starch, but consist of bassorin, or insoluble gum, with some soluble gum and starch. These tubers, produced by different species of Orchids, are highly esteemed in India for their nutritious qualities. The best kinds, which are brought from Candahar and Afghanistan to the Hurdwar fair, sell for a very high price. The kinds produced in India are, however, possessed of much of the same properties.

Along with the starch series are also ranged the different kinds of *Agar agar*, which have been sent from Singapore, and which are so much in request as objects of Chinese commerce. These are varieties of *Alga*, or seaweeds, very similar in their properties to Carrageen or Irish moss, and to Ceylon or Jaffna moss, which is collected at Jaffnapatam. They have by some been thought to be identical with it; but the specimens of Ceylon moss, in the author's collection, do not correspond with all these Agar agars; and it is probable, therefore, that some are yielded by different species of plants allied to the genus of the Ceylon moss, which is now called *Plocaria candida*.]

Arrow-root, kinds of, from Assam, Calcutta, Rutnagherry, Vizagapatam, Borneo, and Java. (*Curcuma angustifolia leucorrhiza*, &c.)

Arrow-root (*Rutnagherry*). The "Kutcherra," or root from which this flour is prepared, grows in all the villages in the southern Kōkun. It is used in the jail, where the quantity made during the year amounts to about 18 maunds, or 504 lbs. West India arrow-root was introduced into the gardens at Rutnagherry by the collector, Mr. Elphinston, in 1840 or 1841; it thrives exceedingly well, but it is not grown to any extent. The quantity of flour prepared from this root is about one maund, or 28 lbs. (annually?) as the native, by whom it is cultivated, has not obtained a sufficient number of plants to extend his experiments, Mr. Elphinston having given up his garden in 1844-45. The jail arrow-root sells from 4¼ to nearly 4½ annas per lb.; whilst the West India arrow-root sells at 5 annas 4 pice per lb., or 3 lb. per rupee.

Arrow-root flour, from Calicut.

Sago meal (*Phœnix*), species of, from Cuttack.

Pearl sago; sago flour; sago cakes; pith of sago palm. Principal food of natives of Malacca, also made by them into soup.

Tapioca, from Calcutta and Rutnagherry.

Tapioca (*Rutnagherry*). Tapioca was also introduced into the gardens at this station by Mr. Elphinston in 1840, and the total quantity of land sown with slips of

this plant, amounts to about three beeghas. This cultivation is carried on in a garden attached to the jail, and on some land belonging to a native. This individual prepares about 15 maunds yearly, and 3 maunds are made in the jail, in all 18 maunds or 504 lbs. The jail tapioca sells at 10 rupees per maund; whilst that prepared by the native realises from 12 to 15 rupees per maund, as he disposes of it by retail sale at Bombay.

Tapioca and arrow-root flour is prepared by rasping the roots down to a pulp, which is steeped in clear water, after which the fibre is separated by the hand, the fine flour being allowed to settle at the bottom; the fibrous part or stuff is eaten by cattle, and seems to be very nutritious. The root may be roasted and eaten as yams. The flour, prepared as above described, becomes purer in proportion to the number of times it is washed in water, which has to be changed twice a day to prevent its souring or becoming acid, which injures the flavour of the flour.

Of the quantity of flour, both tapioca and arrow-root, one-third is consumed at the station, and the remaining two-thirds are sent to parties applying for it from Bombay. The native manufacturer retails his own produce at Bombay, as he makes a greater gain than by wholesale to the chemists and druggists. I have not heard of any Rutnagherry tapioca or arrow-root being exported to England or any other European country."

Flour of *Nelumbium* seeds (*Nelumbium speciosum*), from Cuttack.

Salep, Salep misree, obtained in Calcutta, from the north-west of India.

Plantain meal, from Madras.

Agar Agar.—1st quality obtained from Malacca. A sort of edible sea-weed, which grows on the rocks that are covered by the tide. It is much used for making a kind of jelly, which is highly esteemed both by Europeans and natives for the delicacy of its flavour. From Singapore Committee.

Ditto.—2nd quality, obtained from Macassar (Celebes). It is an edible sea-weed, collected on the submerged banks in the neighbourhood of Macassar by the Bajow Laut or sea Gipsies, for exportation to China. Ditto.

Ditto.—Obtained from Singapore, and collected on the reefs and submerged ledges in the vicinity of Singapore, and constitutes the bulk of the cargoes of the Chinese junks on their return voyage. It is much used there as a size for stiffening silks and making jellies. Ditto.

#### (G.) Sugar Series.

[The increased growth and manufacture of sugar in India have often attracted attention in Europe, in order to ascertain whether it could be supplied in such quantities and at such prices as to contend with slave sugar in home markets. From the larger capital which has been invested in the manufacture of sugar by Europeans, and from the increased exports of sugar from India, it would appear that capitalists are of opinion that this can be done. But the great demand there is in India for sugar for home consumption, and the rapidity with which prices are run up in the interior whenever an increased demand occurs from Europe, have prevented the much larger exports that might have taken place, or the expected profits being realized on its arrival in this country. One thing is very evident, and that is, the great improvement which has taken place in the manufacture of sugar by the different European Companies which have been established in India, as displayed in the specimens sent for exhibition from Cossipore and Ganjam, from the Deccan, and from Shajehanpore. The sugar-candy from Bickaneer is interesting, because it is sent from a district where the sugar is not produced; in fact, from a desert-like country where the sugar-cane cannot be grown. But sugar in a raw state is imported from the plains, and after being purified and crystallized is sent back again and brings a good price,

as it is valued both by Europeans and by natives of rank. These also consume a good deal of the sugar-candy of China.

Among the sugars another very interesting feature is, the variety of plants from which sugar is obtained, and of which specimens have been sent. Though the sugar-cane yields by far the largest quantity, yet in some districts the wild-date palm (*Phoenix sylvestris*) is the principal source, as in some of the districts of Bengal. In the Madras Presidency much sugar is obtained from the Palmyra palm (*Borassus flabelliformis*), and in the straits from the gomuti or sago palm (*Arenga saccharifera*). A specimen has also been sent of sugar obtained from the Neepah, a plant allied to the *Pandaneæ*, or screw pines, and which lines the shores of many parts of the Malayan peninsula, as well as of many of the Eastern islands. The Bassias, which have been mentioned as the sources of a distilled spirit, also yield sugar, though this is more frequently fermented than separated from the flowers in the form of sugar.

Following the sugars, a very good specimen of manna from the tamarisk is displayed, having been sent to the author of this note by Dr. Stocks from Scinde.]

Loaves of sugar manufactured after European and native methods, from Shahjehanpore, in district of Rohilkund.

Sugar (*Saccharum officinale*), from Aska, in Ganjam.

Sugar from the Deccan.

Indigenous Sugar. "Made by the simple process described in the 'Transactions of the Bombay Agricultural Society of 1839.' Could be afforded at 7 to 8 rupees per maund of 84 lbs."—Bombay.

Sugar from sugar factory at Cossipore.

Sugar candy; native crystallized sugar candy; from Bickaneer. Rajah of Bickaneer.

Sugar made from the juice of spathe of the Gommuti palm, from Java.

Date sugar (*Phoenix sylvestris*), from Dacca.

Neepah sugar (*Nipa fruticans*), produced in Burman and Malayan peninsula.

Sugar of Muohwa flowers, or those of the butter tree (*Bassia butyracea*), from Kémaon.

Sugar, manufactured in Dutch high-pressure vacuum pans, and by a new process not generally known, made in common open battery, from Sourabaya, Java.

Sugar, manufactured in low-pressure vacuum pans, from Probolingo, Java.

Yestinado, substitute for liquorice root (*Abrus precatorius*), from Tanna.

Tamarisk manna from Scinde.—Dr. Stocks.

#### CLASS IV.

##### VEGETABLE SUBSTANCES USED IN MANUFACTURES.

[The natural products of this class are separated from the last because they are employed chiefly in the arts and manufactures, or as medicines; yet some of them are also used as articles of diet—as, for instance, many of the fatty oils and gum in some parts of Africa.

##### *Gums, Resins, and Gum-resins.*

In mercantile language, the word *gum* indicates very dissimilar substances—that is, either a *gum*, a *resin*, or a *gum-resin*. But the word *gum* signifies a vegetable exudation which is soluble in water, and *resin* one that is soluble in spirit, while *gum-resin* indicates those which contain both gum and resin. Without chemical analysis, it is not always easy to say to which of these groups a new and unknown substance belongs.

As Africa produces and exports the largest quantity of the gum of commerce, we might expect that some of it would reach India with other African products from the East, or Somali Coast, through Aden and Arabia. Some

fine specimens of gum have been sent from Aden, produced probably by different species of acacia which abound in the arid plains of Africa. In India a good deal of gum is yielded by *Acacia arabica*, and by other species of the same genus. Gum is also yielded by species of other genera, as *Feronia*, *Melia*, *Mimusops*, and a substitute for tragacanth by species of *Cochlospermum* and of *Sterculia*. It would be extremely interesting and important, as showing their application to different purposes in the arts, to ascertain their exact composition, and the means by which the less pure kinds of gums might be purified. Some of these, though not purely such, are more useful for their astringing properties, as those of *Butea*, *Bombax*, *Moringa*, and *Diospyros*. Among the resins, that called *Soodroos*, and by European merchants, *Animi*, and *Copal*, is imported into this country from India. It is the produce of Africa, and forms one of the imports into Aden. The tree yielding it is unknown. This resin has sometimes been thought to be the produce of *Vateria indica*; but this yields a resin which exudes in the liquid state, and is known by the name of *Piney varnish*. Some fine specimens have been sent in bottles, and are in a semi-fluid state. Others are in a dry state, and form a pure resin. A greenish-coloured resin from Coorg, of which the source is unknown, also appears very pure, and might, like the former, be employed for making varnishes. The most abundant of the resins is that of the saul tree, *Shorea robusta*, which is itself an invaluable timber tree. It is used for all the purposes of resin, and for paying the bottoms of boats in India. It is known by the names of *Dammar*, *ral* and *dhoona*. The name *Dammar* signifies resin in general, but is most frequently applied to the resin of a pine, the *Dammara australis*, of which specimens have been sent from Malacca. Among the fragrant resins, the olibanum may be mentioned, which is used in India as incense. That produced in India is obtained from *Boswellia thurifera*, while that imported from Africa is the produce of probably another species of *Boswellia*. Myrrh is imported from Africa, and assa-fœtida, ammoniacum, &c., from the Persian Gulf. *Bdelium*, an inferior kind of myrrh, has been shown by Dr. Stocks to be produced by a species of *Balsamodendron*. Dr. Nicholson has discovered it in Kattywar, and it is probably produced in other parts of India. Benzoin is a well-known product of the island of Sunatra; but a kind is stated to be produced in Malabar, of which the source has not been ascertained. The storax sent by the Rajah of Kotah has probably been imported into India.

The oleo-resins have not attracted that attention which they deserve: the kind called *Gurjun*, obtained from a species of *Dipterocarpus*, yields an oleo-resin very similar to balsam copaiba.

##### *Caoutchouc and Gutta Percha.*

Among these are some original specimens; as the caoutchouc sent from Assam to Mr. Swinton, and the specimens collected by Capt. Vetch, which are very pure, have little colour, and retain all their original properties. New sources of this useful substance are indicated in the specimens from Singapore.

The specimens of gutta percha are interesting, as being some of the original ones sent by Dr. Montgomery to the India House, and from whence specimens were distributed to numerous experimentalists. Professor Solly employed some of them in the analysis which he made on the original introduction of this substance. These are sent by Colonel Bonner, of the East India House.]

(A.) *Gum and Resin Series.*

Gum Babool (*Acacia arabica*), from Bengal.

Gum Arabic, from Aden (imported from Somali coast); Kheir gum of *Acacia catechu*, from Rajpootanah; Junma jegota (*Acacia leucophlea*), from Vizagapatam; Babool taca, keekur gond (*Acacia farnesiana*), from Bengal.

Gum gattie, Babul tree, from interior of Bombay.

Gum Gattie is a gum produced in the Concan, Guzerat, and Dekkan, from the common "babool" or acacia arabica, very similar to gum arabic. Re-exported chiefly to Great Britain: annual importation 360,867 lbs.

Gum from margosa tree (*Melia azadirachta*), from Madura, Tinnivelly, and Palamcottah.

Gum of wood apple tree (*Feronia elephantum*); Pagada jegota (*Minusops elengi*); Mallaga jegota (*Moringa pterygosperma*), from Vizagapatam; Ballee gond (*Sterculia urens*), or spurious tragacanth.

Spurious Tragacanth. Ballee gond, the gum of the *Sterculia urens*. This comes from the neighbourhood of Tanna; it is all that the committee have been able to obtain, and was taken from a private collection. It is not sold in the bazaar of Bombay; it has been sent, at the request of the Central Committee at Calcutta.

Kuteera, or spurious Tragacanth (*Cochlospermum gossypium*), from Meerut.

Gums, small collection in bottles, from Sarawak, Borneo. Resin of saul tree (*Shorea robusta*), from Bengal and Bhagulpore; Guggilam (*Vatica tumbuggaia*), from Canara and Vizagapatam.

Copal, Soondroos—sent from Bombay.

It is imported here from the Persian and Arabian gulfs, and re-exported chiefly to Europe.

Piney varnish (*Vateria indica*), from Malabar and Canara.

Piney resin of dhoop tree (*Vateria indica*), from Canara. Resin of Tendoo, kind of ebony (*Diospyros*), from Rajpootanah.

Meka sta-Dhoona, from Assam.

Thenganet resin, for paying bottoms of ships, from Arracan.

Thenatthu, coating to paper umbrellas and varnish, for manufacture of papier maché; Thetsee (*Melanorrhæa usitata*), used as lacquer, from Arracan.

Black varnish, from Assam. Resin of (*Odina wodier*), from Calcutta and from Meerut.

Nareeda jegota (*Eugenia jambo*), from Vizagapatam.

Pitch of gaup tree (*Embryopteris glutinifera*), from Bhagulpore.

Different sorts of dhoop, a perfume, from Nepal, Bhotan.

Olibanum, saleh gond, Loban (*Boswellia thurifera*), from Chota Nagpore.

Dikamali gum (*Gardenia lucida*), very effective in keeping vermin from wounds, from the interior of Bombay. It exudes in amber-coloured transparent drops about the ends of the shoots, and from thence is collected.

Jelladi pulu (*Calotropis gigantea*), from Vizagapatam.

Resin, Dammar, from Malacca, Java, and Sumatra.

Resins and guttas, great variety, from Sarawak, Borneo. Fir turpentine (*Pinus longifolia*), from Cheera Poonjee hills, Dacca. Resin, from Ullwar.

Balsam storax, in silver box, from Rajpootanah.

Benzoin (*Styrax benzoin*), from Sumatra.

Benzoin, from Malabar and Canara.

Gum resins, as assafetida, ammoniac, &c., imported into Bombay from the Persian Gulf.

Gum Ammoniac is imported into Bombay from Persia and Arabia, and chiefly re-exported to Great Britain. Annual importation, 132,296 lbs.

Gum Gojar. Of this gum no account has been obtained. It was sent in anticipation that an account of it was forthcoming, but none has reached the committee.

Assafetida. This gum is imported from the Persian Gulf and Sindh, and chiefly re-exported to various parts in India. Annual importation, 324,920 lbs.

Bdellium, a kind of myrrh, from Aden.

Bdellium, from Bombay. Two kinds of this gum have been discovered, one, which is thick like wax, and the

other the common dark sort. It is found principally in Persia, Arabia, Cutch, and Sindh, and is chiefly re-exported to Calcutta and China: it is used in medicine. Average annual importation, 177,887 lbs.

Bdellium, from Cutch. This is collected in Cutch; but probably the greater part imported there is from Arabia, and the Somali coast of Africa.

Nepalapi pulu (*Jatropha Curcas*); Mersaklii (*Amyris commiphora*), from Vizagapatam and Ganjam.

Olibanum, from Aden, from Somali coast.

Myrrh, Herabole and Bysabole.

Dragons-blood, from Aden, imported from Sumali coast.

Heraduccum (*Bombay*). "The produce of a large species of ratan, growing on the north and north-east coasts of Sumatra and in some parts of Borneo, and imported in small quantities to Bombay. It is either in oval or round drops wrapped up in flag-leaves, or in large and generally more impure masses composed of smaller tears. It is internally and externally of a dusky red colour, and when powdered it should become of a bright crimson; if it be black, it is worth very little. It is somewhat transparent, and has little or no smell or taste; what it has of the latter is resinous and astringent. Dragons-blood is far preferable to that in cakes, the latter being more friable and less compact, resinous, and pure, than the former. Being a costly article, it is very apt to be adulterated; most of its alloys dissolve like gum in water, or crackle in the fire without proving inflammable; whereas the genuine dragons'-blood readily melts and catches flame, and is scarcely acted on by watery liquors. It is often confounded with gum kino; but a little observation would easily discover the difference. No imports of it took place in 1847-48 or 48-49. In 1849-50, however, 586 lbs. were imported, and re-exported to various places in India.

Gamboge. It is imported from Singapore, China, and the Straits of Malacca, and is chiefly re-exported to Great Britain. Annual importation, 26,804 lbs.

Cutteemundoo, or Kattimundoo gum (*Euphorbia nereifolia*). This gum is described as being useful in cementing iron with other substances, the blade and handle of a knife for instance.

India-rubber from Ficus elastica, collected by Captain Veitch, &c., in Assam.

India rubber, Gum caoutchouc, from Lampung, Sumatra; Manjagatu (*Ficus indica*), Atti jegota (*Ficus racemosa*), from Vizagapatam; Camboley (*Morus indica*), from Paughat.

Gutta-percha. Some of the original specimens sent by Dr. Montgomery to the India House.

Gutta percha (*Isonandra gutta*), from Johore, Malay Peninsula.

Gutta trap used for birdlime (*Artocarpus*), from Singapore.

MACINTOSH & Co. Cambridge St. Manchester, and 73 Aldermanbury, London—Importers, Manufacturers, and Patentees.

1—4 Specimens of India-rubber, from Assam.

5—7 Specimens of India-rubber, in process of cleaning, in masticated block, and in thin cut sheets.

8—10 Specimens of India-rubber in laid sheets, in colours, and in solution.

11 Specimens of India-rubber, laid on various fabrics as material for making waterproof articles.

12 Specimens of India-rubber embossings for making up various fancy articles.

13 Specimens of India-rubber thread for weaving into various elastic articles.

14 Specimens of India-rubber thread for ladies' knitting and crochet work.

Birdlime, bor attock, from Assam.

Varieties of raw caoutchouc and its preparations for various manufactures, consisting of the wood, the coagulated juice, of the caoutchouc from Assam; raw caoutchouc from Assam, Singapore (*Urceola elastica*, the Jintawan of the Malays), from Para, Jamaica, &c.

Caoutchouc in the processes of being cleaned, corru-

gated blocks, sheets cut from blocks, and also in spread sheets.

Caoutchouc vulcanized in a sulphur bath; sulphurized by mechanical mixture; ditto vulcanized; blocks vulcanized; sheets vulcanized for various purposes; thread ditto for elastic fabrics; sheets coloured and vulcanized; embossed and modelled caoutchouc vulcanized; cloth for waterproof clothing and articles of various fabrics; double and single textures vulcanized; sheets *converted*, coloured, converted, and vulco-converted; dough for spreading into sheets, and varnishes prepared of caoutchouc, &c.

The process of treating caoutchouc with sulphur, by means of heat, since called vulcanizing, was discovered by Mr. Thomas Hancock, and patented by him November 23, 1843. The remarkable changes effected by this treatment of caoutchouc are:—1st. Its resistance to the effects of climatic temperature, neither being stiffened by cold nor injured by heat. 2ndly. It resists the destructive action of the common solvents of caoutchouc, merely absorbing them as a sponge does water, but without being dissolved in essential oils. 3rdly. Its greatly increased and permanent elasticity.

These valuable properties, imparted by vulcanizing, have opened to the uses of caoutchouc, previously very limited, many important and extensive applications to manufactures and engineering.

#### (C.) Oil Series.

[This series includes both *volatile* and *fatty*, as well as *solid* oils, or vegetable butters and tallows, as they are also called. India is rich in all the three groups of oils; and among them are some which are little known in Europe, though they are well calculated from their good qualities, abundance, and cheapness, to become valuable as articles of commerce, and from their fitness for candle and soap making. Among the volatile oils are the famed *atr*, *utter*, or *otto* of roses, and with it some fine rose-water from Mr. Godfrey, of Ghazee-pore. *Grass oil*, often called, though erroneously, *Oil of Spikenard*, has been sent from several parts of Central India, as well as from Sumatra, under the name of *Siri*, or Lemon-grass oil. It is probable that they are all produced by species of the old genus *Andropogon*: though, without authentic specimens of the plants from each place, it is not possible to identify these correctly. It is probable that one of them is the sweet cane, or sweet *calamus* of Scripture. Sandal-wood oil and the essence of *Ketgee* or *Keora* (*Pandanus odoratissimus*), are highly esteemed in the East, as well as that prepared from the *Uggur*, or *Agila* and *Ahila*, the aloes-wood of Scripture. With all these may be enumerated several essential oils from the Moluccas, as well as scents from Ghazee-pore. The latter are solutions of the scents in the finer fixed oils.

With these volatile oils may be noticed the camphor of Sumatra, often called Barus camphor, which has been forwarded from Borneo, *via* Singapore. This kind, found in a solid state in small pieces within the wood of *Dryobalanops camphora*, is so highly valued by the Chinese, as to be bought by them at a much higher price than they sell their own purified camphor for, though Europeans cannot perceive that it is in any way inferior.

This is probably as suitable a place as any for noting the Kayu Garu, or *Agala* wood, Lignum aloes, and Calambac wood of commerce, which is produced in Sumatra and Malacca, as also in Silhet. In the last, by *Aquilaria agallocha* of Roxburgh, figured by the author in his "Illustrations of Himalayan Botany." That of Malacca may be produced by the same species; that of Siam is produced by the *Aloerylum* of Loureiro. It is highly esteemed in China and in Turkey. In the former it is reduced to a

fine powder, mixed with a gummy substance, and laid over small slips of wood, which are burned in their temples to give out a fragrant odour.

The true Spikenard, or Nardos, compared by the Arabs to the tail of an ermine, is arranged here with aloes-wood, as it also forms a scent highly esteemed in India and other Eastern countries.]

#### Volatile Oils.

Otto or atr of roses (*Rosa glandiflora*), from Ghazee-pore.

Oil or atr of roses, from Rajpootana.—Rajah of Kotah. Rose-water, by Mr. Godfrey, from Ghazee-pore.

Grass oil (*Andropogon Martini*; *Schanantus? muricatus*: *A. calamus aromaticus*, Royle), from Malwa.

Grass oil, with the grass and seed, from which it is extracted, contributed by R. C. Hamilton, Esq., from Malwa.

Lemon grass or siri oil, from Sumatra.

Oil of cloves (*Oleum caryophylli*), from Madras.

Cajaputi oil, Kaya pateh, from Malacca.

Sandal-wood oil, Chendana tel, Sundana yennai (*Santalum album*), from Mangalore and Canara.

Ketgee oil (*Pandanus odoratissimus*), from Rajpootana.

Kitichee; Uttur khera, green-pined screw pine, white flowered; Uttur khetkee, green-pined screw pine, yellow flowered (*Pandanus odoratissimus*), from Rajpootana.

Uggur, or oil of aloes-wood, from Nepal.

Compound oil of aloes-wood, from Rajpootana.

Essential oil of aloes-wood, from Ghazee-pore.

Saffron oil, from Rajah of Kotah, Rajpootana.

Scents of chumpa, jasmine, &c. (*Michelia champaca*, *Jasminum grandiflorum*, and *J. sambac*), from a native perfumer at Ghazee-pore.

Essential oils and scents, from the Moluccas.

Camphor, commonly called Barus camphor, from Borneo, much esteemed in China, erroneously said to be used to flavour the Chinese camphor.

Kayu garu, Uggur, Agila, Eagle or aloes wood, from Sumatra and Malacca.

Spikenard, balchur and jatamansi, *Nardostachys jatamansi*, both used for making scents. Himalayas.

#### Fatty Oils.

[These are very numerous in India, being employed by the natives both as articles of diet, for anointing their bodies, and for burning in oil-lamps. Some of them are cultivated by the agriculturist, as the poppy, linseed, sesamum, ramtil, or *Guizotia*, ground-nut, and the different kinds of mustard-like plants, so also castor-oil and safflower. The shrubby *Jatropha curcas* is grown in hedges, &c. Oil is also expressed from the seeds of large trees, as the Cocoa-nut, the Kurrunj, Chironjee, Neem, Margosa, Poontree, and many others, of which the peculiar properties are not well known, as fitted for different purposes, but all can be obtained in large quantities.

But the solid oils, or vegetable butters, such as the cocoa-nut in temperate climates, are of great interest, and several have been sent from India. Of these, that of the *Bassia butyracea*, from the neighbourhood of Almora, in the Himalayas, has several times been written about, but it occurs only in small quantities; that of the *Bassia latifolia*, or Muohwa tree, has been analysed by Mr. Hardwick, who has sent specimens of the *Bassic* oil, which he obtained from this vegetable fat, which closely resembles the solid oil of another species of *Bassia*, that is, *B. longifolia*, which is common in the Madras, as *B. latifolia* is in the Bengal, Presidency. This has already been mentioned as secreting sugar in its flowers, which, being fermented, yields, by distillation, the common arrack of the country. From the great abundance of both species, a plentiful supply of the oil might be obtained, and at a cheap rate. The natives could supply their own

wants with the oils from the annual plants. Another solid oil, of which the tree (*Vateria indica*) has already been mentioned as yielding piney varnish, is still more substantial in nature, and is commonly called vegetable tallow. It was examined some years since by Professor E. Solly, and its fitness for candle-making clearly demonstrated. Though the tree is abundant, it is doubtful whether the oil which is expressed from the seeds can be had in any considerable quantity—probably from the want of a regular demand. In addition to them, a vegetable tallow has been sent in a gourd from Sarawak, in Borneo, and another in bamboos from Malacca, though the trees yielding them are not mentioned. They may be the same as the *Stillingia sebifera*, which yields the vegetable tallow of China, or they may be yielded by species of *Bassia* or of *Pternandra*. One of them may be the *Minia batta*, or stone oil, which was introduced from Borneo some years since.

But without specimens of the plants or trees yielding the several oils, it is impossible to identify them when the number is so great of trees yielding not only oils but solid fats. Mr. Low mentions that several species of Diptero-carpus yield a fatty oil, which having been sent to England, has been extensively used under the name of vegetable tallow and vegetable wax. The seeds of one of the species, called *Meneabang pinang*, yield a very large proportion of oil, which, on being allowed to cool, takes the consistence of sperm. This has been used at Manilla in the manufacture of candles. In Borneo it is called by the natives indifferently "*Minia meneabang*," or "*Minia tankawan*." Another oil, expressed from the seed of a tree called *katiow*, is called "*Minia katiow*." It burns in lamps with a bright and clear flame, and emits an agreeable odour. The *Minia kapayang* is another oil held in esteem for cooking by the natives of Borneo. It is yielded by the tree, called *Panguim edule* by botanists. Mr. Low mentions, moreover, that the seeds of many of the forest trees, as the *niate* or gutta percha of the Malay Peninsula, produce edible oils of fine qualities. He also refers to wood oils, called "*Minia kruing*," which are obtained by cutting a large hole in the tree, into which fire being placed, the oil exudes. The wood oil, or *gurjun* of Silhet, is obtained in something of a similar manner from different species of Diptero-carpus.

The solid oils or vegetable fats sent from Bombay, under the names of *Kokum* and of *Kikuel* oil, the first yielded by the seeds of *Garcinia purpurea*, and the other by the seeds of *Salvadora persica*, are remarkable for their solid consistence, and may probably be applicable to a variety of useful purposes.

The collection of oils is probably the largest in number, and at the same time one of the most valuable, that has ever been sent to this country. Though many have contributed in forming the collection, the Commissary-General of Madras, Captain Horsley, of Palameattah, and T. Bishop, Esq., of Tanjore, may be mentioned as each sending several varieties of oils.

A specimen of vegetable wax is interesting. It has been sent from Singapore, and is said to be obtained from the island of Billitor—yielded, perhaps, by one of the above-mentioned species of Diptero-carpus.]

Linseed and linseed oil, tisse tel, from Moorshedabad. Linseed, grown in the interior of Bombay.

Sesamum oil (*Sesamum orientale*), (black and white), from Moorshedabad.

Gingely seed (*Sesamum orientale*), from Vizagapatam and Ganjam.

Tillee oil and seed (*Sesamum*), from Gwalior.

Gingely oil, Manehy noonæ, til ke tel, hind, nullenai, tamool (*Sesamum orientale*), grown in all parts of India, Vizianagrum Zemindary, Tanjore; gingely seeds, from Hydrabad.

A kind of mustard (*Sinapis toria*), from Ghazeepore and Meerut. Mustard oil (*Sinapis glauca*), from Calcutta.

Annaloo noonæ (*Sinapis nigra*); Rai ke tel, hind; Kadrogo yennai, tam, from Tanjore.

Castor-oil seed, large and small, from Bellary.

Castor-oil (*Ricinus communis*), from Madura and Tinnivelly; Chitta anmethum; arindia; ehitamenachoo yennai. Cold-drawn castor-oil, arandee ka tel, from Tanjore.

Jungle lamp oil, Adivia aumedum (*Ricinus communis*), from Tanjore. Erandee; katoo aumanakoo yennai. Castor oil; miniak jahar oil, from Java.

Jatropha oil. The uses of this oil from the *Jatropha curcas* as a drying oil have as yet hardly been tried, but it leaves a fine varnish-like polish on drying. As a medicinal oil for external applications and external use it may be found valuable. The family to which the plant belongs would indicate caution in its use as regards the human body. The plant grows extensively over the Bombay Presidency. The oil could be supplied at about a rupee for seven pints.

Bhoga Bhirinda oil (*Jatropha curcas*), from Beerbhoom.

Poppy seeds and poppy-seed oil, Gasagesa noonæ (*Papaver somniferum*), from Tanjore and Calcutta.

Oil of seed of *Argemone mexicana*, Calcutta.

Koosum oil (*Carthamus tinctorius*); Safflower seeds (*Carthamus tinctorius*); oil and seed of saul tree (*Shorea robusta*), from South-west Frontier and Rajpootana.

Cheeronjee berries and seeds (*Chironjia sapida*, now *Buchanania latifolia*), from Rajpootana and Moorshedabad.

Valuse nune (*Guizotia abyssinica*), from Vizagapatam.

Ram til (*Guizotia oleifera*), from Calcutta, Vizagapatam, Ganjam.

Valisaloo oil, Valisaloo noonæ (*Guizotia oleifera*), from Vizianagrum Zemindary, Vizagapatam, and Ganjam.

Poonseed oil (*Calophyllum*), from Madura, Tinnivelly, and Palamcottah.

Pinnacottay oil, Ponna noonæ (*Calophyllum inophyllum*), from Tanjore.

Oondee oil (*Calophyllum inophyllum*), Tannah.

Oondee oil. Expressed from the nut of the *Calophyllum inophyllum*. It is used as a stimulant in medicine externally and internally.

Almond oil, Badum noonæ, Badoomai yennai (*Amygdalus communis*, probably *Terminalia catappa*, which is called the almond tree in many parts of India), from Tanjore.

Poonga oil, Kanuga noonæ; Kaju ka tel; Poongar yennai, from Tanjore.

Caju apple oil, Moontha maunnerly noonæ (*Anacardium occidentale*); Kajoo ka tel; moonthery yennai, from Tanjore.

Neem oil; expressed oil from margosa berries (*Melia azadirachta*); Margosa seeds, from Bellary.

Neem oil, Vapa noonæ (*Melia azadirachta*); Neem vappa yennai, produced all over India.

Margosa oil, Vapa noonæ (*Melia azadirachta*); neem ka tel, vappa yennai, from Tanjore.

Katchung oil, from ground nut (*Arachis hypogæa*), from Java.

Ground nut oil. Owing to its thinness and freedom from rancidity, containing little stearine, it is, Dr. Gibson thinks, used in some countries for watches and other delicate machinery. As a salad oil and a cooking oil in India it is, from its freshness, superior to olive oil. Quantities of it are annually supplied to the medical stores at Bombay. It could be supplied at five rupees per 28 lbs.; without allowing profit, at two annas and ten piers per pint.

Kurrunj oil, from Tannah. Expressed from the nut of *Galedupa indica*, now the *Pongamia glabra*. It is used

externally as a stimulating embrocation, and given internally to horses with colic spasms.

Kanagu nonæ (*Pongamia glabra*), from Vizagapatam.

Country walnut, Dessy akhroot (*Aleurites triloba*); Simboleë (*Bergera koenigi*).

Hingun or Hingota (*Balanites ægyptiaca*), oil of *Moringa pterygosperma*.

Mooneela grain oil, Varoo samgaloo noonæ (*Dolichos biflorus*).

Nilackadelai yennai, from Tanjore.

#### Solid Oils.

Cocoa-nut oil (*Cocos nucifera*), from Calcutta, Malabar, Madura, Tinnivelly, and Sarawak.

Treble refined castor oil, from Messrs. SAÏNTE of Cossipore, near Calcutta; Tonkaya noonæ (*Cocos nucifera*); Narel; Thenga yennai, from Madras.

Vegetable butter or ghee (*Bassia butyracea*), from Kémaon.

Muohwa oil (*Bassia latifolia*) from Moorshedabad.

Epie oil, Ippa noonæ (*Bassia latifolia*) Canara; Illopo zennai (*Bassia latifolia*), from Mangalore.

Illoopoo oil (*Bassia longifolia*) from Madura and Tinnivelly; Illoopoo oil, Ippa noonæ, expressed from seeds of *Bassia longifolia*, India; Illoopoo yennai, from Tanjore.

Vegetable tallow, or Piney tallow, from fruit of Dhooptree (*Vateria indica*), from Malabar, Canara, and Mangalore.

Kokum oil (*Garcinia purpurea*). Kokum oil is obtained from the dried fruit of the *Garcinia purpurea*. It is a concrete oil. It is used as an article of food; also as a medicine externally in eruptive complaints, and internally in affections of the bowels. It is also said to be exported to England for making pomatum, as a substitute for bears' grease.

Kikuel oil. The produce of the solid part of the seed of *Salvadora persica*, peeloo. The pulpy part of the seed is watery, but all parts of the tree have the strong mustard-like flavour. The roots of the tree have strong medicinal power. It is common in Palestine. It is imported here from Guzerat, and is chiefly consumed in Bombay. Annual importation, 3,843 lbs. The tree is supposed to be the mustard-seed tree of Scripture.

Vegetable tallow, from Malacca, and Sarawak, Borneo.

Vegetable wax, Gutta podoh, from Billiton.

Coorookoo oil, from Madura and Tinnivelly.

Koodree oil and Kaisseon oil, from Chota Nagpore.

Shemmandu oil, from Palamcottah.

Khatzum (*Vernonia anthelmintica* ?), from Bombay.

#### (D.) Dyes and Colours.

[The natives of India being celebrated for the variety as well as for the brilliancy of the colours which they employ, this group may be expected to be rich in the number of raw materials. It is so, to a certain extent; but we are unable to say anything respecting many of them, as their exact applications are unknown. There is very little doubt that a careful investigation of their properties would amply repay any scientific dyer who would direct his attention to them. Some of these dyes are, no doubt, well known; as indigo, of which fine specimens have been sent by D. Jardine, Esq., from Jessore, and others from Cuddapah. One kind, sent by Mr. Fischer, is interesting, as being the produce of the leaves of a tree (*Wrightia tinctoria*), which differs entirely from the common indigo plant (*Indigofera tinctoria*). Turmeric, safflower, sapan, and myrobolans, and others, are well known.

The different kinds of madder root require to be carefully distinguished with respect to their properties—as, for instance, the munjeet of different parts of India. The *al* and *ach*, as yielded by different species of *Morinda* in Central India, and employed in dyeing the permanent deep

red calico called *khurwa*, which is much worn by water-carriers. Both these are distinct from the *chay* root (*Oldenlandia umbellata*) of the Coromandel Coast. The mangkuda root has been sent from Malacca, Java, and Celebes, to which the old name of the *chay* root, *Morinda umbellata*, is applied in the lists from Singapore. The different lichens from the Himalayas and Scinde, the roots and herbs, flowers and fruits, from Arrakan and the Indian islands, as well as from different parts of India, all require careful investigation.]

Specimens of indigo, from Babacully, in Jessore, Messrs. M'Nair and Co., and from Joradah factory.—Sent by D. Jardine, Esq., of Calcutta.

Indigo (*Indigofera tinctoria*), from Hart and Simpson's factory, from Arbutnot's factory, and from Cuddapah market, from Cuddapah and Madras.

Best indigo and Kotah indigo-seed, from Kotah.

Indigo, and other dyes, Rao of Cutch. Indigo is chiefly grown for home consumption.

Pala indigo (*Wrightia tinctoria*), Mr. Fischer, from Salem.

Gaju gum, used in dyeing, from Celebes.

Madder, from Assam, Calcutta, and Aden.

Lichens, from Himalayas and from Sindh.

Mangrove bark, Kaboung, yields chocolate dye, from Arrakan.

Myrica bark, from Himalayas.

Bark and wood, Ting nyet, dark purple dye, from Arrakan.

Sagah bark, and Samak bark, from Singapore.

Lopisip bark, from Celebes.

Purple flowers used as a dye in Arrakan:—

Sapan wood (*Casalpinia sapan*), from Bengal.

Bulu wood, Bunchong; Mangkudu root? (*Morinda umbellata*) red dyes from Celebes and Java.

Safflower, Kasoomba (*Carthamus tinctorius*) from Assam and Dacca.

Tisso flowers, light red dye (*Butea frondosa*) from Tanna and Bengal. They are used for dyeing a light red colour, a favourite colour for turbans.

Annotto (*Bixa orellana*), from Assam.

Hursingar flowers, yellow dye (*Nyctanthes arbor tristis*) Rajpootana and Cuttack.

Abutilon striatum? from Assam.

Haradah berry, from Hill tracts of Orissa.

Myrobolans (*Terminalia citrina* and *Terminalia bellerica*), from Moorshedabad, Cuttack and Assam.

Marking nut (*Semecarpus anacardium*), from Assam.

Reroo, hair of fruit of (*Rotifera tinctoria*), from Assam.

Turmeric (*Curcuma longa*), from Assam.

Seeds, root, and powder, prepared for colouring (*Morinda citrifolia*), from Rajpootana.

Root of Mangkudu (*Morinda umbellata*) from Malacca.

Sapan-wood root (*Casalpinia sapan*), from Java and Philippine Islands.

Chay root (*Oldenlandia umbellata*), from Timnevelly, Palamcottah.

Al or ach root (*Morinda tinctoria*), from Rajpootana.

Nutgalls, Danghy hurritochoer, and Assokat, from Assam.

Reroo (purple dye), Thit nan weng (chocolate dye), Krit tel and Thee dan (red dye), from Arrakan. Kayu kadrang (yellow dye), from Malacca.

Woondy (*Calyxacion longifolium*), from Bombay. Flowers exported to Bengal for dyeing silk.

Avaraiputta, Saracundraputtah, from Palamcottah.

Usburgh and Ukkul beer (*Datisca cannabina*), yellow dye, from Lahore.

#### (E.) Tanning Substances.

[The same observation may be made respecting tanning substances that we have made respecting the dyes, that is, judging from the results, the raw materials employed must be possessed of the best qualities as astringents. Some of these are well known as the dif-

ferent kinds of Myrobolans, but which are chiefly employed in dyeing. The *Emblie myrobolans*, which is more astringent, is, however, the product of a very different tree (*Emblie officinalis*) from the others. Gall-nuts are imported, by the Persian Gulf, into India from the same regions which supply Europe. Tamarisk galls are used in some places where they are abundant, as is pomegranate rind. The divi divi is being grown in Bengal, and produced of excellent quality; but a new species of *Casalpinia*, called Teree, from Chittagong, is found to be useful for the same purposes. The bark of *Acacia arabica* is the most frequently employed in most parts of India, but that of *Cassia auriculata* in the Peninsula. Several others require examination. The acacia is abundant in the forests of Scinde, as is the mangrove along the shores of the Indus. Dr. Stocks has proposed the preparation of extracts from these barks, as was some years since done by Dr. Gibson, in order to save the expense of freight for bulky barks, and enable them to come into the market with catechu, terra japonica, and gambir, which are already so well known and extensively employed, and come from as distant parts of the Indian empire. Kino also might be more extensively supplied, as the tree producing it has been discovered in many of the forests of India. The kino of *Butea frondosa* might be used for the same purposes as it is possessed of similar properties.]

Aonla berries, Emblic Myrobolans (*Phyllanthus emblica*), from Rajpootana; Marada (*Terminalia alata*); Buhera, Safaed mosslee, Hurrah (*Terminalia bellerica*), from Mirzapore.

Teree (*Casalpinia*), A. Scoria, Esq., from Chittagong.

Divi divi (*Casalpinia scoraria*), grown in the Botanic Garden, Calcutta.—Dr. Falconer.

Mangrove bark (*Rhizophora Manglesii*), from Arracan, Malabar, and Singapore.

Babool bark (*Acacia arabica* and *Acacia catechu*), from Madras, Sindh, Shahjehanpore, Rohilkund, and Assam.

Avaraputtai, Tangada jegota (*Cassia auriculata*), from Vizagapatam; Saracondraputtai (*Cassia fistula*), from Madura and Tinnivelly.

Jamoon bark (*Eugenia jambolana*), from Cuttack.

Peal bark, from Cuttack.

Saul tree bark (*Shorea robusta*), from South West Frontier, and Vizagapatam.

Gallnuts, from South-West Frontier.

Pomegranate bark, Daruncka puckl, Dadima fegota (*Punica granatum*), Kénaon, Vizagapatam.

Galls of Tamarisk, Sumrut ool Usl (*Tamarix Indica*), from Bombay and Lahore.

Catechu extract (*Acacia catechu*), from Rutnagherry; Kut, from Malabar, Moorsshedabad, Calicut.

Kino gum, Vangay (*Pterocarpus marsupium*), from Malabar.

Dhak gum, Choon gond (*Butea frondosa*), from Rajpootana, Cuttack, and Meerut.

Moduja fugutie (*Butea frondosa*), from Vizagapatam.

Gambir (*Uncaria gambir*), from Singapore.

Mochrus (*Bombax malabaricum* and *Bombax heptaphyllum*), from Bengal and Meerut.

#### (F.) Fibrous Substances.

[Under the head of fibrous substances, cotton is arranged with flax and hemp. It is not, however, of the same structure as these, being considered by botanists to be formed of elongated cells, while the others are formed of true ligneous fibres; but as all are applicable to the purposes of weaving and of rope-making, it is more convenient for practical purposes to treat of them together.

From the enormous extension of cotton manufacture in this country, any increased supply of the raw material from new or from old sources is a subject of paramount

importance, and has hence for some time engaged much of the public attention. The Indian collection exhibits a very large number of specimens from a great extent of territory. But the cotton is of very different degrees of quality and of length of staple. The indigenous cotton of Asia which is met with in commerce seems all to be produced by varieties of one species, the *Gossypium indicum*, often called *G. herbaceum* by botanists; but it is truly herbaceous only in cold climates. The cotton of this when compared with American species is distinguished by the shortness and often by the coarseness of its staple, and this, notwithstanding that the matchless muslins of Dacca, as well as of other districts of India, have for ages been manufactured with it. This is owing partly to the care with which the cotton is selected and prepared by the native weavers, and partly to the delicacy of touch of the Hindoos, which enables them to spin a staple which is too short for machinery. It is probable that some of the cotton grown near Dacca was of finer quality than the rest: at all events it is known that it had one peculiarity, that of not swelling in the process of bleaching, and making it, therefore, suitable for the manufacture of fine muslins, the so-called "webs of woven air," and which were attempted by being called in this country "the shadow of a commodity."

It has been inferred that moisture of climate is essential to the production of good cotton. This is no doubt the case, but it must be combined with a suitable soil, for some of the cottons from Java are as coarse as those from the driest parts of India. Some of the indigenous cottons of India are, however, of sufficient good quality to be suitable for many of our manufactures—as, for instance, the cotton produced in Nagpore and Berar, provinces of Central India; also that of Broach, Surat, Coimbatore, and Tinnivelly, which are districts situated along the coasts of the Bombay and Madras Presidencies. Great complaints are, however, made by the manufacturers of this country, and very justly, that Indian cotton is most frequently sent in so dirty and adulterated a state as to be troublesome and expensive to work up; a lower price is, therefore, given for it, and yet this price has to cover the expenses of carriage and freight of the dirt as well as of the cotton. The cultivator complains of the low prices paid him for his cotton, though he has, in some measure, his own carelessness to blame, though the defects due to him have been greatly aggravated by the systematic adulteration of middlemen. Those practically best acquainted with the cotton districts of India are of opinion that the only hope of amendment depends upon the settlement among the natives of European agents, or upon the appointment of Inspectors.

Numerous attempts have been made to grow cotton from American seeds in India, and though it is often stated that the experiments have usually ended in failures, this is far from having been the case, for the specimens of cotton which were grown on the experimental farms, and have since then been preserved in the India House, and are now exhibited, display all the qualities of good cotton. Plants growing in the neighbourhood of the old farms retain all the characteristics of good cotton; while there is no reason to believe that the expenses of culture were greater in former times than they have proved to be in the late experiments, when good prices have been paid to the actual cultivators, and a handsome profit has been realized on the sale of the cotton in this country. The experiments have failed in some districts apparently from the unsuitableness of climate; but they have succeeded, and the cultivation is progressively increasing in other districts, such



as Candeish, Belgaum, Dharwar, Coimbatore, and Tinnivelly. In the last-mentioned district it is particularly interesting to observe that the cultivation has been taken up by gentlemen from Manchester, though it is generally preferable, because more profitable, to allow the natives to cultivate the cotton, and to agree to purchase it from them when grown. In Candeish, Belgaum, and Dharwar, the culture of American cotton by the natives of India was gradually extending; and it was expected that in the season of 1850-51 about 9,000 bales of Indian-grown American cotton would pass through the station of Dharwar on their way to this country. This cotton can be laid down in Liverpool, all expenses paid, at  $3\frac{1}{2}d.$ , and has frequently sold for  $6d.$  and  $6\frac{1}{2}d.$  a pound. The whole of the details are given in the author's work "On the Culture and Commerce of Cotton in India and elsewhere." London, 1851.]

#### Cotton.

Cottons grown in the Experimental Farms of the East India Company from the year 1818 to 1850—India House. Indigenous cottons, from Madras Presidency, Dacca, Agra, Jullundur Doab.

Raw cotton with seed, and after the seed has been extracted, from Gwalior.

Cotton unpicked, from Rajpootana.

Cotton, from Broach, Khandeish, Belgaum, and Dharwar.

Cotton, New Orleans. This is grown in the Belgaum Collectorate. The price mentioned, viz., 12 annas per maund, is the entire cost growing, &c., and ginning.

Cotton (country). This is grown in the Belgaum Collectorate. The price is 10 annas per maund.

The following is a statement of the cultivation of cotton in the Dharwar and Belgaum Collectorates for the year 1849-50:—

#### Dharwar Collectorate.

|                      | Cultivation<br>in 1849-50. | Yielding about<br>Candies of 784 lbs. each. |
|----------------------|----------------------------|---------------------------------------------|
| Country cotton . . . | 225,685                    | 18,135                                      |
| New Orleans . . .    | 15,573                     | 1,557                                       |
|                      | <hr/> 241,258              | <hr/> 19,692                                |

#### Belgaum Collectorate.

|                      | Cultivation<br>in 1849-50. | Yielding about<br>Candies of 784 lbs. each |
|----------------------|----------------------------|--------------------------------------------|
| Country cotton . . . | 145,216                    | 10,000                                     |
| New Orleans . . .    | 3,058                      | 180                                        |
|                      | <hr/> 148,274              | <hr/> 10,180                               |

Of this cotton one-quarter is kept in this country for native manufactures, and three-quarters exported to Great Britain.—Bombay Report.

Cotton wool, from Rao of Cutch. This is a small specimen of the Cutch cotton, which is grown in small quantities for home consumption only.

Ladom and Oopum, two indigenous cottons, Bourbon, and Nankeen cotton, from Salem.—G. F. Fischer, Esq.

Cotton pods from American seed, from Madras.

Mexican or New Orleans cotton from Government Farm, cleaned by saw gin, from Coimbatore.—Dr. Wight.

Oopum, or native Indian cotton, cleaned by American saw gin, from Coimbatore.—Dr. Wight.

Raw cotton and cottons for spinning yarns, from Assam and Moulmein.

Raw cotton (*Gossypium herbaceum*) from Palembang, Sumatra.

Cotton grown as second crop on rice land, cleaned and uncleaned; upland variety, grown both as annual and perennial, cleaned and uncleaned, from Java.

Cotton, from Pernambuco seed, grown at Sarawak, in Borneo.

Fishing lines of cotton, from Calicut.

Ropes made of cotton (*Gossypium herbaceum*), from Coimbatore and Bellary.

Cotton twist, from Palembang, Sumatra, Celebes, Java.

#### (G.) Fibres.

[The production of fibres fit for weaving into cloth and for rope-making is hardly of less importance than that of cotton; and India abounds in so great a variety of them, as is evident even from the collection exhibited, that there is hardly a want that might not be supplied from thence. It is curious, though India abounds in both the hemp and the flax plant, that neither are cultivated there on account of the fibre for which they are so much valued in Europe. The flax plant may, however, be seen forming an edging to many fields of corn, being cultivated on account of its seed (linseed), which is now both exported and oil expressed from it, while the stalks are thrown away, though flax has been prepared from them of good quality at Manghyr, &c. The hemp in the plains of India is cultivated solely on account of its intoxicating properties (see Class III. (D.), p. 873). But in the Himalayan mountains, where the climate is more suitable, strong rope and canvas are prepared from the fibre, which the difficulties of access alone prevent at present from becoming extensive articles of commerce. But for these India possesses a vast number of substitutes, some of which may yet come to rival them in the commerce of the world, from the extent of their useful properties. It is curious that to one of these a name is applied which would seem to be the original of our English word hemp, and which is itself derived from *hauf* and *hennip*. *Crotolaria juncea*, which in habit somewhat resembles Spanish broom, is cultivated in most parts of India for its fibre, which is used for the same purposes as hemp, and is called *sun* and *sunnee* in different parts of India, but, in the Madras peninsula, *janapum*. It is a useful substitute for hemp, but usually inferior in strength to what is called brown Indian hemp, the produce of *Hibiscus cannabinus*, also called *sun* in Western India, but *Ambaree* at Bombay. Several other species of *Hibiscus*, though not extensively cultivated, are similarly useful, as well as others of the same natural family. *Aschynomene cannabina*, or the *dancha* of Bengal, is similarly used; but the species and varieties of *jute* or *pat* have become the most extensive articles of export, not on account of the strength, but from the length, fineness, and great cheapness of the fibre. It is used for making the common kinds of lines and floor-cloths, but also, it is believed, of late years, for mixing with other substances in the manufacture of different fabrics. The chemical means which are now adopted for improving the appearance of many of these fabrics, has made that of jute applicable to many purposes of furniture. Another group of these fibres is yielded by what are sometimes called liliaceous plants, such as the agave, or great aloe, as it is sometimes called, the Yucca, the Sansevieria, the pine-apple, and even the plantain—all of which a variety of specimens have been sent from the southern parts of India and the islands of the Indian Ocean. Some of these have already been applied to useful purposes, and specimens of the twine and rope made with them have been sent by several individuals; but in great variety by Dr. Hunter, of Madras, who has also shown that many of them are able to take a variety of colours. Some fine fabrics have already been made with the fibre of the pine-apple, plantain, and Sansevieria: all of them might be employed for making paper. The plantain is especially abundant, being grown in every village on account of its fruit, and its stems are applied to no use.

Some of the palms also yield fibres useful for rope and mat making, as the coir obtained from the husk of the cocoa nut, the Eजू or black Gummuti fibre obtained from *Arenga saccharifera*, also that of the Palmyra and of the *Chamærops* of Beloochistan.

But the most remarkable, and what will probably become the most useful, are the fibres of two plants which were formerly placed in the genus *Urtica*, or nettle, but are now referred to the nearly allied *Boehmeria*. One of these is particularly interesting as being very closely allied to if not identical with the far-famed China grass. This plant has been known for many years, as it was one of those which was subjected to experiment by the late Dr. Roxburgh, when public attention was turned, in the year 1803, to India for a supply of materials for canvas, cotton, and cordage. The author of this note observed in the year 1836, with respect to this plant and Dr. Roxburgh's observations—"It is interesting to find in the same family with the hemp, the *Urtica tenacissima*, or *Caloee* of Marsden, *Rami* of the Malays, a native of Sumatra, also of Rungpore, where it is called *Kunkhora*, and which Dr. Roxburgh found one of the strongest of all the vegetable fibres, which he subjected to experiment. Average weight, with which lines made of the different substances broke were, *Asclepias tenacissima*, *Jetee* of the Rajmahl mountaineers, 248; *Urtica tenacissima Callooe*, 240. The strongest Sunn, *Crotolaria juncea*, 160. Hemp, *Cannabis sativa*, grown in the year 1800, in the Company's hemp farm near Calcutta, 158, but much stronger when tanned. Europe hemp, however, was always found stronger than Sunn, though not more so than the others. Dr. Roxburgh speaks of the beauty, fineness, and softness of the fibre of this plant, and says he learnt from a friend resident at Canton that the grass-cloth of China is made of this material. It is cultivated in Sumatra for the fibres of its bark. The Malays use it for sewing-thread and twine, and for making fishing-nets. It is as readily cultivated as the willow from cuttings, grows luxuriantly in the northern as in the southern parts of India, throws up numerous shoots as soon as they are cut down, which may be done about five times a-year. Dr. Roxburgh, however, found some difficulty in cleaning the fibres of this plant, notwithstanding his anxious desire to succeed with this substitute for both hemp and flax. *Urtica heterophylla* is another Indian nettle, which succeeds well in every part, and of which the bark abounds in fine white, glossy, silk-like strong fibres (Roxburgh). The stinging properties of the nettle are well known, but they are all exceeded by the last-mentioned plant, as well as by *U. crenulata* and *stimulans*."—*Illustrations of Himalayan Botany*, p. 334.

In the year 1811 the Court of Directors of the East India Company imported three bales of the *Caloee* hemp which had been cultivated in the Botanic Garden at Calcutta by Dr. Buchanan, who was of opinion that the plant was identical with the *Urtica nivea* of Willdenow. The Court ordered one bale to be sent to Messrs. George Sharpe and Sons, who reported, on the 4th February 1812, that having brought the *Caloee* plant to the state of hemp for the use of cordage, a thread was spun of the size of those spun in the king's rope-yards, which bore 252 lbs., whereas the weight required to be borne in his Majesty's yards by Russian hemp of the same size is only 84 lbs. A letter from Mr. Lee, of the Society of Arts, dated 14th June 1845, stated that when the article is cleaned it is strong, soft, and free. Under proper management, the fibre of this plant would be of more value than the best Russian hemp for most of the purposes for which hemp is

used, and it may be made so fine as for many uses to answer the purposes of flax.

Dr. Buchanan mentions that the plant is cultivated in the district of Dinagepore and Rungpore; and in the year 1833, and again in 1836, Major (then Captain) Jenkins, the zealous Superintendent of Assam, called the attention of the Agricultural Society of India to the valuable fibre of the *Rheea* of Assam or *Urtica nivea*; and now we have several of the officers who are placed under Major Jenkins sending specimens of this *Rheea* from different parts of Assam.

We have seen that Dr. Roxburgh had been told that the grass-cloth of China was made of this material. The truth of this statement, however, was doubted, as other plants have also been stated to be those employed, as the plantain, pine-apple, *Corchorus*, *Sida tiliacifolia*, and even the hemp itself. The discussion having been revived of late years, one of the educated Chinese employed in the tea culture in Assam, stated that the nettle-like plant growing in Assam was like that which afforded the material for making grass-cloth in China. The Agricultural Society of India, in the year 1847, addressed Dr. Macgowan, then stationed at Ningpo, to make inquiries on the subject. Dr. M. writes that grass-cloth is manufactured from a plant called *Chu ma* by the Chinese, and which he supposes may be a species of *Cannabis*; but Dr. Falconer rightly observes that the description given by Dr. M. is entirely that of the species of *Boehmeria* (formerly *Urtica*), called *B. nivea*, or *tenacissima*, by botanists, or of a newly-allied species. Some specimens which were subsequently received confirmed Dr. Falconer's opinion, that the *Chu ma* is the same plant as the *Boehmeria nivea* of botanists. It may be stated that the specimens, though imperfect, of the China grass-cloth plant in the Exhibition closely resemble, though they do differ a little in the appearance of the bark from the pieces of the Assam plant in the Indian collection. It is important to state that, for all practical purposes, Mr. Sangster considers the produce of the two plants as being identical. The Indian plant is found abundantly in Assam and Caehar, in the Shan country, and in Ava, and in the Tenasserim provinces, besides in the other above-mentioned localities. Hence there is an abundant supply of a very valuable material, which may shortly become an important article of commerce, by the adoption of suitable measures for the culture of the plant, and for facilitating the separation of its fibres.

Another species of *Urtica*, the *U. heterophylla*, is hardly less important, from the appearance, softness, and strength of its fibre, but it is probably not so abundant. Dr. Wright particularly calls attention to its fibre, as well as to that of the *Yercum*, or *Calotropis gigantea*, which belongs to the same natural family as the *Jetee* or *Asclepias tenacissima* of Roxburgh. The whole Indian series would afford a fruitful source for experiment and interesting observation, tending greatly to increase our supply of fibre, and to develop the resources of the country in which they are so abundantly produced.]

*Hemp, Flax, Pine-apple, Plantain, Nettle Fibre, &c.*

Hemp, true (*Cannabis sativa*), with twine and canvas, from Kénaon and the Himalayas generally.

Flax, from Monghyr.

Fibre, hemp, and cordage, Dunchai (*Æschynomene cannabina*), contributed by Messrs. Thompson, manufacturers, from Calcutta.

Plantain fibre of the Philippine Isles (*Musa textilis*), cultivated by Dr. Roxburgh, near Calcutta.

Plantain fibre, from Dacca.

Fibre of plantain stem (*Musa paradisaica*), from Singapore.

Plantain fibre (*Musa paradisaica*); plantain fibres, dyed orange, green, and red: oakum, or tow, of plantain stalks; rope from fibres of plantain stems; strong thread, whip and line plait, from plantain stems; tarred rope, made from plantain fibres, Dr. Hunter, from Madras.

Pine-apple fibre, prepared for weaving, from Assam.

Pine-apple fibre and twine, from Singapore.

Pine-apple fibre, from Celebes and Java.

Flax from pine-apple, from Calcutta.

Fibres of pine-apple (*Ananas*), from Travancore.

Fibres and oakum of pine-apple, from Madras.

*Sansevieria zeylanica*, Morgahee, grown in the division of Cuttack, and used for bowstrings. The hemp therefrom is prepared by scraping each leaf, when in fresh water, with a knife, and separating the fibres from the vegetable substance. The preparation admits of no other process without impairing the strength of the fibre.

Bowstring hemp, fibres of (*Sansevieria zeylanica*), from Cuttack and Malabar.

Fibres and oakum of marool (*Sansevieria zeylanica*); fibres of marool, dyed orange, red, maroon, and green, from Dr. Hunter, of Madras, and from Coimbatore.

Ropes and fibres of marool, from Madras and Coimbatore.

Rope, made of fibre of aloe (*Agave americana*), from Coimbatore.

Fibres and oakum of large aloe, dyed orange, red, maroon, and green; Whipcord, from large aloe, from Madras.

Fibres of the aloe; Agave. Cordage made from the aloe, from Madura.

Fibre of the small aloe (*Agave? vel Aloe?*), orange, red and crimson.

Rope made from the fibres of wild aloe, from Madura.

Fibres of the small or garden aloe; *Sansevieria*. Fibres made into oakum of the small or garden aloe; from Madras.

Fibres and oakum of small species of *Yucca*, from Madras.

Flax, so called, but is the produce of *Boehmeria candicans*, a plant nearly allied to that yielding China grass, first and second quality, dressed, from Java.

Nettle fibre in various stages, *Talli rami*, from Singapore.

Fibres of Neilgherry nettle (*Urtica heterophylla*), sent by Dr. Wight, from Neilgherries.

Caloee hemp (*Urtica tenacissima*), grown by Dr. Roxburgh, nearly fifty years ago, near Calcutta.

Rhea fibre (*Urtica tenacissima*), from Rungpore in district Moorshedabad, and from Major Jenkins and other officers in Assam.

Fibre of *Urtica vel Boehmeria nivea?* or China grass, imported by Mr. W. Sangster, of Cheapside, from Assam.

*Sun, Jute, and other Tropical Substitutes for Hemp and Flax.*

Fibre of *Sun*, or *Crotolaria juncea*, from Calcutta.

Thin rope of fibres of *Janapum (Crotolaria juncea)*, from Coimbatore.

Suffed and lal monty pat (*Corchorus olitorius*), from Rungpore in district Moorshedabad.

Two other varieties of *Jute*, or *Corchorus olitorius*, from Bengal.

Theng-ban-shaw, Pa-tha-you-shaw, Shaw-phyoo, Ngant-sounghoro. Specimens of raw materials and rope made therefrom; from Arracan.

Shau-nu, ee-gywot-shaw, from Arracan.

Brown Indian hemp, Ambari and Sun (*Hibiscus cannabinus*), Dr. Gibson, Bombay.

Thick rope of Palungeo (*Hibiscus cannabinus*) from Coimbatore.

Fibre of *Hibiscus strictus* and *Sabdariffa*, grown by Dr. Roxburgh.

Areah lota, Maranhoree lota, Moonga lota; bright fibre hemp for making rope, from Assam.—Major Hannay, Baboo Demanath, and Lakenath.

Bark string and ropes Putwa (*Bauhinia racemosa*) from Bhagulpore.

Fibre, Tongoose (*Asclepias tenacissima*), from Madras. Fibres of bark of yercum (*Calotropis gigantea*), from Madras.

Fibre of a species of *Urena?* from Calcutta.

Fibre of Parkinsonia stalks (*Parkinsonia aculeata*), from Madras.

Pulas cordage (*Butea frondosa*). Bhabooree, a grass rope. Chehoor, a forest tree. Patoo, or Asta cordage. Beerbhoom.

Bark of Trap tree (*Artocarpus*), from Singapore.

Thread for making cloth; Mazankoree thread; Reah fibre and thread; Pat thread; Reha fibre; from Assam.

Bark of the Sasa tree; of Roxburghia, and of Artocarpus, from Assam.—Captain Reynolds and Mr. Simons.

Coir rope from cocoa-nut husk (*Cocos nucifera*), from Calicut in Malabar.

Ejow or Gummuti fibre. The hairy outer covering of *Arenga saccharifera*, or Gummuti Palm (see Griffith's Palms of British India), as collected from the tree. This fibre is much esteemed for making ropes, especially cables, for which purpose it is peculiarly adapted from not being liable to injury if stowed away below when wet with salt water. Ditto, separated from the stiff fibres. Ditto, prepared for manufacture or exportation. Ditto, prepared as sennit or coarse line for making ropes or cables.

Fibres of Palmyra leaf (*Borassus flabelliformis*), from Madras.

Fibre of *Chamærops Ritchiana*, from Beloochistan.—Dr. Stocks.

Gogoo rope, from Cuddapah.

Wackanoor fibres, from Travancore.

Bow strings of fibres, from Wynaad and Calicut.

#### (Ga.) Cellular Substances.

Pith-like stem of *Æschynomone aspera*, formerly *Hedysarum lagenarium (Shola)*, common in wet and marshy parts of India.

Solah, from the vicinity of Calcutta. The natives make hats, caps, bottle and glass covers, life-preservers, and toys of it.

Inner bark of the Himalayan birch (*Betula bhopputra*), Himalayas.

#### (H.)—Timber and Fancy Woods used for Construction and for Ornament.

A collection of 117 specimens of Indian and a few Ceylon woods made up into the form of books by the late Dr. Roxburgh. The Tamil names are written upon many of the specimens. Mr. Wilson Saunders has added greatly to the value of this collection, and the two following, by having ascertained the specific gravity of all the principal woods, and made notes on the working qualities of many of them.

A collection of 51 of the principal woods, chiefly from the Bengal Presidency and Himalayan Mountains, in good-sized specimens, sent to the East India House by Drs. Roxburgh and Wallich. The properties of the greater number of the principal Indian woods have been detailed by Dr. Roxburgh, in his "Flora Indica" and in his "Coromandel Plants."

The following are the botanical names of the trees yielding these woods:—

*Quercus lappacea*, lanceæfolia, and fenestrata.

*Castanea indica*. *Corylus lacera?*

*Taxus nucifera*. *Prunus puddum*.

*Juglans regia*. *Juglans pterococca*.

*Artocarpus Chaplasha*. *Cedrela toona*.

*Terminalia citrina*. *Terminalia chebula*.

*Odina Wodier*. *Cynometra polyandra*.

*Diospyros racemosa*. *Sophora robusta*.

*Gmelina arborea*. *Nerium tinctorum*.

*Tetranthera nitida*. *Phyllanthus longifolius*.

*Swietenia febrifuga*. *Lagerstræmia Regiæ*.

*Vateria lanceæfolia*. *Osyris peltata*.

*Santalum album*. *Olea fragrans*.

*Scytalia Longan*. *Scytalia trijuga*.

*Mespilus japonica*. *Averrhoa Carambola*.

*Acer lævigatum*. *Elæagnus spec.*

*Eugenia* spec. *Rhododendron arboreum*.  
*Mimosa odoratissima*. *Cassia sumatrana*.  
*Rhizophora odoratissima*. *Andrachne apetalata*.  
*Dombeya melanoxylon*. *St. Helena ebony*.

Selections from a collection of 457 woods of timber trees and shrubs from the Bengal Presidency and its eastern frontier, sent by Dr. Wallich to the India House. A duplicate collection was given to the Society of Arts, and is enumerated in the Transactions of the Society. Vol. XLVIII., part ii., pp. 439 to 479. 1831.

A collection of 15 cups, turned out of Indian and Himalayan woods, sent by Dr. Wallich to the India House.

Mahogany wood (*Hæmatoxylon campechianum*), grown in the East India Company's Botanic Garden, near Calcutta, and a tea-caddy made out of it.

A collection of cubes of Teak wood, with their specific gravities, from the Marine Department in the India House.

A collection of 262 specimens, with their weights and principal properties, from Tinnivelly, Travancore, Paulghaut, North and South Canara, with some from Penang, forwarded by Colonel Frith to Lieutenant-Colonel Bonner, Military Storekeeper, East India House.

Specimens of the deodar wood (*Cedrus deodara*) of the Himalayas, and of the cypress (*Cupressus torulosa*) of the Himalayas. J. F. Royle, M.D. These are exhibited, because so many landed proprietors have planted the hardy deodar on their estates, and it is likely to become a valuable timber tree. The cypress is less hardy.

Teak, marked S T. This specimen, from the forests of Soonda, in the Madras territories, is sent for comparison with the Northern or Surat teak, which is grown in a drier country and a more stubborn soil. Price varies from 9 rupees to 22 rupees per 20 cubic feet when brought to the coast.

Teak, marked N T. This is the Surat teak just mentioned: it is said to be much harder and more durable teak than that from either Malabar, Canara, or Moulmein.

Kao wood. This grows in the hills near Kurachee, and more abundantly on the Belovat Hills to the northward. A round box turned out of it. This has been ascertained, by Dr. Stocks, to be a species of olea or olive, of which he has sent specimens to Dr. Royle. It is used in Scinde for making combs; Dr. S. thinks it might be useful for wood engraving.

Specimens of wood of the following trees, growing in the districts of Bareilly and Pilibet, in the Rohilcund division:—*Phyllanthus Emblica*. *Melia azadirachta*. *Cedrela*. *Shorea robusta*, two specimens. *Mimosa serissa*. *Calyptanthus*, sp. *Dalbergia sissoo*. *Acacia Arabica*. *Acacia catechu*. *Nauclea cordifolia*. *Mulberry*. *Bassia latifolia*. *Bombax heptaphyllum*. *Nauclea parvifolia*. *Wrightia mollissima*. *Plum. Grewia*. *Rohunee*? *Chowlae*? *Urseina*? *Goshum*? *Khumar*?

Grown in the district of Mirzapore:—*Bijeedar diptercarpus* (bijeedar). *Asun Pentaptera glabra*. *Abnoos Diospyros* (ebony). *Sukooa Conocarpus* spec. *Terminalia bellerica*. *Terminalia sused moolsee*. *Terminalia hurrah*. *Phyllanthus emblica*.

Specimens of wood of the following trees, grown in the late Dr. Carey's Botanic Garden at Serampore, near Calcutta:—*Eugenia polypetalata*. *Robinia macrophylla*. *Dalbergia latifolia*. *Mimusops hexandra*. *Cinchona grattissima*. *Diospyros sapota*. *Diospyros montana*. *Dillenia pentagyna*. *Dalbergia ougeinensis*. *Careya sphaerica*. *Gmelina arborea*. *Erythrina ovalifolia*. *Nageia Putranjiva*. *Dalbergia* sp.?

Timber, growth of the Tennesseim provinces:—*Sassafras* wood, sp. of *Laurus*. *Mountain erythrina*. *Sterculia fetida*. *Mountain ebony*, spec. of *Bauhinia*. *Mergui red wood*. *Mergui black wood*, *Dalbergia latifolia*. *Tavoy lancewood*, one of the *Apocynæ*. *Fagraea fragrans*. *Pinus Latteri*. *Tectona grandis*. *Ingaxylocarpa*. *Careya arborea*. Four specimens of *Diospyros*. *Heretaria minor*. *Vitex arborea*. Species of *Grewia*, *Rosewood*, *Thanaka*, and *Wild Sandal-wood*. *Jarool*, *Lagerstroemia Reginea*. *Hopea odorata*. *Pterocarpus Wallichii*. *Calophyllum*.

Nine specimens of timber from Bhaḡulpore, in the division of Patna.

Grown in the province of Chittagong, and supplied by Captain Marquard:—*Goorgetiah*, or *Dactylocarpus*. *Butlenah*, or *Conocarpus*. *Kalee bale*, or *Diospyros melanoxylon*. *Melanoxylyum*, black ebony. *Koom Koyre*, *Acacia* spec. *Chukrasse*, *Chickrassia tabularis*.

Grown in the neighbourhood of Calcutta:—Specimens of *Adenanthera pavonina* and *Santalum album*. Wood and plank.

Grown in Assam, and sent by Major Hannay:—*Top sopa*. *Laurus sassafras*, *Goondoora*. *Terminalia*, *Bhota*. *Hindoo*, *Palm Toan*. *Oak*, *Hingoree*.

Timbers grown in the forests of Assam, and received, under their local names, from Mr. Martin:—*Saul*, *Poma*, *Cattul*, *Ratta*, *Babul*, *Nahoo*, *Sullock*, *Korai*, *Agar*, and *Cham*.

*Nadosur*, contributed by Captain Reid.

Timbers grown in the province of Arrakan:—*Moo-tso-ma*, *Bhaman*, *Parawa*, *Tuwwot*, *Thengonet*, *Kyaudevet*, *Teing*, *Tswanhyee*; *Pyaing*, two specimens; *Theratsoing*, *Pywa Tulli*, *Therock*, *Pyanany*, *Thekuddo*, *Tuwot*.

The following specimens of woods were received from Mr. Blundell, Commissioner of the Tennesseim Provinces, in 1835, under the native names here given. They remained from that period to 1847, being twelve years, exposed to the destructive influence of white ants, &c., when, at the expiration of that time, they were reported on by the then Officiating Superintendent of the Honourable Company's Botanic Garden, in October 1847, as follows:—

#### TIMBER from the PROVINCE of AMHERST.

*Povin-gnyet*. Used for house posts and rafters. It is a kind of Jarrool, a good serviceable wood, and would do for piles, posts, and beams.

*Tshiet-Khyeen*. Used for house posts. A superior kind of crooked-grained *Saul*.

*Eng-gyeng*. Also used for posts of religious buildings. A useful wood, but subject to split.

*Gan-gan*. A very strong, tough, hard, crooked-grained, fibrous, red wood, which would do for machinery or any purpose requiring the above properties.

*Myeng-kha*. A useful wood, like *Babool*. *Acacia arabica*.

*Ma-thloa*. Used for house posts; probably *Artocarpus integrifolius*, or *Jack-wood*.

*Bhai-bya*. Ditto. *White Jarrool*.

*Meet-gnyoo*, fruit-tree. It is a red-coloured, useful, strong, heavy wood, probably a species of *Mimosa*.

*Nao*. Used for house posts; the leaves, flowers, and roots are said to be used for medicine. It is a brown, substantial, solid wood, not liable to the attacks of insects.

*Zee-byion*. This is a compact, close wood, like *Lagerstroemia*, or *white Jarrool*. It is used for house posts, and is liable to split, but is free from the destructive influence of insects.

*Pyeen-ma*. House posts, carts, boats, paddles, oars, &c., are made from this, which is a capital wood, a kind of *Saul*, and would answer for all the purposes of common *Saul*.

*Kya-zoo*. This is a very heavy wood, like *Saul*.

*Maza-neng*. This is a close-grained wood, nearly allied to *Teak*. It is used for house posts, carts, boats, paddles, oars, &c.

*La-phan*. A heavy, solid, large-sized timber, but rather liable to injury from a peculiar insect, not white ants.

*Nyaung-lan*. *Saul*, of a peculiar kind, employed for beams, rafters, and boat-building. The root is used as umbrella stocks.

*Kywon-gaung-noay*. A close, heavy, compact, tough, yellowish-white wood, of which house posts and rafters, &c., are made.

*Ban-boay*. It is a strong and useful wood, a kind of *Mimosa*, employed as house posts.

*Moma-kha*. Employed for gun-stocks; it is a reddish,

softish wood, close and compact, fit for turning purposes, and exempt from attacks of insects.

Tha-byion. A useful timber, probably *Eugenia*.

Tha-khwot. This wood is used for sandals; it is a kind of white Teak.

Tha-bwot gye. This is a good heavy valuable timber, somewhat like iron-wood.

Theng-gan. Employed for house posts, carts, boat-buildings, paddles, and oars. It is an excellent compact wood, fit for gun carriages.

Taup-sha. Employed for house posts, and would answer for common carpentry, but it is subject to split; the bark is supposed to be medicinal.

Kiep-maup. Employed for cart-wheel spokes. Superior wood, free from attacks of insects; the tree is said to have an edible fruit.

Yoga-theet. The wood is used for carved images, and the bark used as soap.

Kiep-yo. A heavy, good wood, but small, used for house posts and rafters.

Thiem. Used as house posts, rafters, and general purposes of carpentry.

Myaun-go. White Sissoo, used for rafters.

Myaup-loaut. *Cedrela*, a kind of superior Toon.

Eng. Wood used for boat-building, and produces oil. It is a strong, heavy, useful, grey wood, suited for beams, piles, and the like.

Nga-soay. This is a solid, very heavy, reddish wood, and answers for house posts and rafters.

Tan-labet. A heavy, white wood, employed for house posts and other common purposes. It is not liable to injury from insects.

Koup-ha. This is a light, soft wood, not subject to injury from insects. It is probably *Nauclea cadamba*, and is employed for carved images.

Zeng-bywom. Employed for house posts. It is a useful wood, equal to Jarrool.

Anan. Used for constructing temples. It is a yellowish-white, heavy wood.

Yammandy. Used for carving images and making drums. It is a useful and valuable wood.

Ban-kha. Used for house posts, and other common purposes. It is a peculiar kind of wood, colour grey.

Seet-seen. Used for the construction of religious houses. It is a red, compact, very ponderous, and highly valuable wood.

Teng-khat. This is a heavy white wood, solid, and fit for turning purposes; used for rice-pounders, &c.

Tha-nat. It is a kind of grey Teak.

Kyway-thoay. Is a strong, solid wood; probably will prove to be a kind of *Acacia*. Used for house posts and rafters.

Mya-ya. Hard and close-grained wood, used for rafters; it is strong and durable, and would answer for beams, &c., being exempt from the attacks of insects.

Tswot-ba-lwot. This is said to be a fruit tree; the wood resembles Jarrool.

Bijion. This is used for house posts, rafters, and the like purposes; it is a heavy, compact, grey, close-grained wood.

Theet-to. This is said to be a fruit tree; the wood is employed in boat-building, making carts, &c.; it is a dark-brownish grey, hard, heavy wood.

Oun-thuay. A white soft wood, not subject to injury from insects; it is employed for common carpentry.

Kya-nan. This is a most hard, close-grained, ebenaceous wood, of dark red colour, used for house posts, musket-stocks, and spear-handles.

Than-ky. The fruit of this tree is employed for ring-worm. The wood is like Saul.

Meng-ba. Used for house posts and rafters. The wood looks like a kind of Saul, and would answer all the purposes of that wood.

Theet-ya. Employed for rice-grinders or pounders. It is a superior, compact, close, tough, brown wood, fit for anything requiring great strength and durability.

Ka-theet-nee. Employed for house posts, boats, and

carts. It is a heavy, hard, grey wood, rather liable to injury from insects.

Na-kyeen. Employed for house posts and rafters. This is the Sundrie wood Calcutta (*Heritiera minor*), where it is so common as to serve for fire-wood, although from its superior qualities for buggy-shafts, hackery or cart axles and wheels, and other purposes requiring great strength and toughness, it is highly prized.

Tsoay-dan. Heavy, hard, tough wood, not subject to insects, and, being tough and short, it is suited for wheels, musket-stocks, &c.

Pa-ra-wa. A hard, red, compact wood, with large fibre, and fit for gun-carriages or other similar purposes. It is exempt from attacks of insects. It is used for spears and arrows.

Tshan-tshay. A useful wood, but liable to attacks of insects, and to split.

Pinnai. This is said to be a fruit tree; the wood affords a yellow dye, and is a compact, handsome, yellow wood, suitable for common cabinet purposes. It is probably an *Artocarpus*.

Pad-dan. Used for making drums and musical instruments. It is a kind of red Sander's wood.

Tshaup-yo. Used for house posts and musket stocks. It is a heavy white wood, exceedingly strong, but liable to attacks of insects.

Toung-bien. Used in boat-building and for making carts. It is a strong, heavy wood, well adapted for handles of tools, &c.; it is probably a kind of Teak.

Kywon. A kind of Teak wood.

Daup-yat. Employed for rafters; it is a beautiful yellowish-white compact wood, but has a tendency to split. The leaves are used as a dye.

Dien-neung. Used for rice-pounders; it is a close-grained, strong, compact, brown, hard wood.

Tseet. Employed as house posts and in boat-building. Saul of small calibre.

Theet-phlyion. This is used for fan-handles; it is a useful white wood, and would answer for common carpentry; it resembles *Mimosa serissa*.

Thab-ban. This is used for boat-building and making carts; it is a kind of Teak, but rather heavier than the usual kind.

Kywon-bo. This is used for house posts, rafters, and oars; it is probably a sort of Teak.

Bep-than. Used for making handles for spears and swords; it is a superior wood, and looks like white Jarrool.

Lammay. Used for house posts; it is a red, light, but useful timber, like Sandal-wood, and is free from attacks of insects.

Kiep-dep, ditto, a kind of Saul.

Bhyeng-tseng. This is a close-grained, compact, grey wood, fit for general purposes, and seems to be exempt from attacks of insects.

Tshwai-lwai. Used for musket stocks and sword sheaths; it is a hard, red, crooked-grained wood, fit for cabinet work.

Liep-yo. Used for making carpenters' tools; it is a very compact and heavy, but small-sized timber.

Peng-lay-oun. Used for spear handles; it is a most valuable wood, compact, homogeneous, and very heavy, of a deep brown colour and fine grain, having no tendency to split, and being exempt from attacks of insects.

Raung-thmoo. Used for house posts; it is a kind of Teak.

Thammai. A strong, handsome wood, like *Ægiceras*, or box-wood.

Thep-yeng. Said to be a fruit tree; the trunk affords a compact, fine-grained wood.

Toung-tba-khwa. This is a capital wood for any purpose, gun-carriages or gun-stocks.

Mala-ka. This is used for gun-stocks and carpenters' tools; it is a close, compact, but small-sized wood, fit for hand-spikes, wheel-spokes, and the like.

Toung-tha-byiou. Used for house posts; it is a strong, red, heavy wood, a kind of *Mimosa*.

Yetha-byay. This is used for house posts and boat-building; it is a strong wood, suited for door-frames and common carpentry.

Thanna-dan. Said to be a fruit tree; it is a reddish-brown, heavy wood, fit for machinery or other purpose requiring great strength; it is totally exempt from attacks of insects, but somewhat liable to split.

Than-that. Used for stocks of various instruments; it is a capital wood, and seems to be a kind of Saul.

Gyo. Used for house posts, ploughs, hand-spikes, &c.; it is a close-grained, compact, fine wood.

Yeng-taip. It is a strong useful wood for posts and common carpentry.

Lep-dwat. Used for spear-handles and sword-sheaths; it is a fine-grained, white wood, fit for turning purposes and picture-frames; it is probably the same kind of *Nauclea* which is used for similar purposes in Bengal.

Tsekka-doun. This is said to be a fruit tree; the wood is used for house posts, rafters, and boat-building; it is like Teak, but much disposed to split.

Lien. Used for house posts and rafters. It is a most valuable compact wood, homogeneous and very heavy, of deep-brown colour and fine grain, and also exempt from attacks of insects.

Moutha-ma. Bark used for blue dye, a fine-grained, compact, red wood, but liable to split; it would answer for hand-spikes. It resembles *Myrtus pimentas*.

Pa-ngan. Used for boats and oars; it is a compact white wood, and is also in use for making musical instruments. It seems to be *Gmelina arborea*.

Toung-than-gyee. A hard, compact wood of dark-brown colour.

Kha-boung. A strong wood but small, as strong as oak. The fruit is said to be used for rubbing on buffaloes to keep off flies.

#### TAVOY SPECIMENS OF TIMBER.

Kywon-bo. Bastard teak. A soft wood like *Nauclea*.

Kywon-ma. A variety of the above.

Thingan-kyaup. Employed in boat, ship, and house building, for carts, &c.; it is a close-grained, heavy, strong wood.

Kadwot-nee. Used for boat, ship, and house building. It seems to be a kind of *Cedrela* or *Toon*.

Kaung-thmoo-yoep-say. Ditto ditto. A rough strong wood, used for posts and carpentry.

Toung-bhien. Ditto ditto. Light porous wood like Jarrool, used besides for doors and common or inferior carpentry.

Miaup-bout. Ditto ditto. Answers as *Toon* wood for furniture and other purposes.

Tha-bhan. Ditto ditto, and for making canoes.

Takep-nee. Ditto ditto ditto. Very strong, close-grained, heavy, light-coloured wood.

Ka-nyeng-kyaung-khyay. This is likewise used for boat, ship, and house building, carts, &c. It appears to be red *Jarrool*, yields an oil, and is exempt from attacks of insects.

Ka-nyeng-pyan. Ditto ditto. Heavy grey wood used for hand-spikes.

Ka-nyeng-kyaung-khyay. Ditto ditto. Strong heavy wood rather disposed to split. It would answer for beams and sleepers.

Aman. Used for boat building, house posts, and planking. A small tree.

Mee-kyaung-kyay. Ditto ditto. A heavy wood exempt from attacks of insects, and might be employed for door frames and strong carpentry purposes.

Peng-lay-byeen. Ditto ditto. Small tough wood, might be used for hand-spikes and spear-handles if sufficiently free from knots.

Kyay-tsay-gyee-khyay. Ditto ditto. A heavy compact dark wood like walnut, and would do for gun stocks.

Kyay-tsay-bayoun. Ditto ditto. Useful for common carpentry, like *Terminalia chebula*.

Pautheet-ya. Ditto ditto. A good white-coloured wood, rough, and fit for boat building.

Theet-ya-nee. Used for boat building, house posts, and planking. Close-grained brown wood, subject to split, but would answer for hand-spikes.

Theet-ya-pyiou. Ditto ditto. Heavy strong wood, probably a kind of Jarrool.

Pyeng-khado. Ditto ditto. Small-sized, close-grained, and heavy red wood, would answer for hand-spikes, and if the trees are large, for better purposes.

Khamoung-nee. Ditto ditto. Heavy wood, exempt from the attacks of insects; it would answer for general carpentry purposes.

Khamoung-pyiou. Ditto ditto. Small-sized, light, but compact yellowish grey wood.

Kharaway-nee. Ditto ditto. Porous, but rather heavy strong wood, not liable to injury from insects.

Theet-ta-gyee. Ditto ditto. Would answer for door-frames, house posts, and common carpentry. It is something like red Jarrool.

Kengthep-guyung-yept. This is employed for house posts and planking. It is a light inferior wood, but the specimen is much eaten by insects, and hardly of any use except to show the quality of the wood.

Kengthep-Phevot-kyay. Employed for house posts and planking. It is a sound small-sized timber.

Pee-daup. Ditto ditto. Seems to be *Acacia serissa*.

Katso. Ditto ditto. Strong *Cedrela*-like wood, and would do for the purpose for which *Toon* is employed.

Penglay-oun. Ditto ditto. Strong, rough wood, like *Acacia serissa*.

Patseng-ngo. Ditto ditto. A very superior high-coloured aromatic wood, resembling *Toon* or mahogany.

Eng-beng. Ditto ditto. Useful for common carpentry.

Ngoo-beng. Employed for house posts and planking. Like very strong *Toon* wood.

Pyaung-pyion. Ditto ditto. A yellow compact heavy wood.

Kyep-ye. Ditto ditto. A kind of Teak.

Thabyay-nee. Used for house posts. It is a strong, close-grained, brownish-grey wood.

Bhan-bhway. Ditto ditto. Like *Sissoo*.

Thmeng-ba. Used for house posts and making cotton cleaners. It is like red Jarrool.

Toung-byeng. A kind of Saul, but of red colour.

Thiem. A serviceable timber, and would do for the better sort of carpentry.

Kouk-ko. Red Jarrool, employed for the bottom planking of boats, &c.

Kanna-tso. A fruit tree, having very tough, close-grained wood.

Ma-yam. An indestructible strong dark, heavy, red wood, especially valuable for all purposes requiring those properties.

Toung-kha-ray. Red Jarrool as before, used in boat building.

Pinnay. Strong, close-grained, yellow wood, like Jack. *Artocarpus integrifolias*.

Lienman (Orange). Heavy, close-grained, light-coloured wood, like that of *Terminalia bellerica*, but of small diameter.

Mala-ka. Small-sized strong wood, suited for hand-spikes.

Patseng-tsway. Small-sized strong wood, which would do for posts and hand-spikes.

Tseng-byioun. Said to be a fruit tree, having compact greyish-brown wood, fit for carpentry purposes.

Tag-nyeng. A useful wood for furniture. The colour and grain are like *Toon*.

Tha-byoo. A heavy close-grained wood.

Toung-bhaut. Employed for handles of knives and spears. Rough knotty wood.

Pan-loun. Used for house posts and other building purposes. It is a red, close-grained wood.

Myeng-ta-bep. Ditto ditto. Strong bluish-grey wood, adapted for hand-spikes.

Noalee-byeng. Ditto ditto. Close-grained, strong, heavy wood, of small diameter, adapted for hand-spikes.

Thmeng-tshout. Ditto ditto. Fit for door frames and

boat beams; and is a brown heavy coarse wood of small diameter.

Bha-ta-ka. Useful for common carpentry, like red Jarrool.

Peng-lay-kaboay. Employed as house posts; a heavy, but small sized, wood, fit for hand-spikes.

Tsoay-dan. Used for gun-stocks, and might answer, like Sissoo, for gun-carriages.

Meep-thua-ban. A small-sized close-grained grey wood, employed as spear handles, spade shafts, posts, &c.

Theet-ya-han. Used for house posts. It is a close-grained Teak.

Bep-than. Ditto ditto.

Bep-won. Ditto ditto. But it is an inferior timber, like Mangoe wood.

Eng-way. Ditto ditto. Light close-grained yellowish-white wood.

Toung-byiou. Ditto ditto. Close-grained brown wood, subject to split, adapted for hand-spikes.

Mya-kamaun. Used for knife and spear handles. It is an ebenaceous strong black wood, which might be highly useful to cabinet-makers.

Wouthay-khyay. A compact, strong, yellowish-white wood, but of small size.

Zoo-lat. Small compact, heavy, yellowish-white wood.

Daup-yan. Used for house posts and other building purposes. It is like *Myrtus pimenta*, and would serve for hand-spikes.

Yau-ma-lay. Used for house posts. This is a strong rough white wood, like white Jarrool, but heavier.

Timber forwarded from Moulmein by J. R. COLVIN, Esq., Commissioner of the Province, 1847, under their native names, six of which have since been identified by Dr. Falconer during his visit to the Teak forests of the Tenasserim Provinces in 1848-49:—

*Lagerstromia macrocarpa*, Pyen-ma, commonly known under the name of Jarrool.

*Careya sphaerica*, Bambooe.

*Cyrtophyllum fragrans*, Anan, of the *Nux Vomica* tribe; one of the hardest, most compact, and heaviest woods known.

Pyen-ma and Kazaret. Undetermined.

*Pterocarpus indica*, Podauck, one of the Leguminosæ, called Rosewood. It is a very beautiful and hard compact timber, closely resembling the Andaman wood.

Indike, Ebony.

Anan as above.

*Hopea odorata*, Thengan, of the *Dipterocarpeæ* or Saul tribe; a very strong but coarse-grained timber.

*Inga xylocarpa*, Pyangadean, belonging to the *Acacia* tribe, commonly called the iron wood of the Arrakan provinces, very hard, dense and durable.

*Pterocarpus indica*, Paddock, as above. Rosewood of the Tenasserim provinces, a very beautiful, hard, compact timber resembling "Andaman wood," which is occasionally seen in the Bazaar of Calcutta.

#### TIMBER AND FANCY WOODS FROM THE MADRAS PRESIDENCY.

[The properties of many of the timber trees of the Madras Presidency have been described in Dr. Roxburgh's works, as quoted above. Dr. Wight and J. Rohde, Esq., have given much valuable information respecting many of the timbers enumerated in the following lists in the printed Report of the Proceedings of the Madras Central Committee, but of which only a single copy has as yet reached this country.]

NOTE.—Name in (3) Telinga; (4) Hindee; (5) Tamool.

From Madras.

Noonah wood.

Portia wood. 3. Gengarauni kurra. 5. Porsum marum (*Hibiscus populneus*).

Woodiah wood. 5. Oathya marum (*Odina Wodier*).

Eroombala wood. 5. Iloombilly marum (*Ferula buxifolia*).

Satin wood. 3. Billa kurra (*Chloroxylon Swietenia*).

Atta wood. 5. Authau marum.

Ven teak. 3. Takoo kurra, Hindee, Sagwan. 5. Ven-takoo marum (*Tectona grandis*).

Ausena wood, *Pterocarpus*.

Mango wood. 3. Mamide kurra, Hindee, Am. 5. Mangkuttai (*Mangifera Indica*).

Saul wood. 3. Yapa. 5. Aussence (*Shorea robusta*).

Peddawk wood. 3. Peddawkoo kurra.

Pala wood. 3. Pala kurra. 5. Paulai marum (*Mimusops hexandra*).

Trincomallee wood (*Berrya ammonilla*).

Rosewood. 4. Sissoo. 5. Eatty or Vutty marum (*Dalbergia Sessoides*).

Chittagong wood. 5. Aglay, or Sitticam marum. (*Chickrassia tabularis*).

Moulmein teak, Takoo kurra, Sagwau, Taka marum (*Tectona grandis*).

Pegu wood, Jarkoo, Sagwau, Jake marum (*Tectona grandis*).

Malabar teak-wood, Takoo kuna, Saguan, Take marum (*Tectona grandis*).

Simboorah teak-wood, Takoo kuna, Saguan, Take marum (*Tectona grandis*).

Coimbatore teak-wood, Takoo kuna, Saguan, Take marum (*Tectona grandis*).

Thimbeam teak-wood, Takoo kuna, Sageran, Take marum (*Tectona grandis*).

2. Angelly wood. 5. Anjelly marum.

2. Model, or puteba Ootoo wood.

2. Thingam wood.

2. Pengandoo wood.

2. Oorooopoo wood.

2. Ravirardoo wood, Kadirardoo kurra.

2. Congoo wood.

Autcha wood. 4. Abnoos. 5. Autcha marum (*Diospyros ebenaster*).

2. Peemah wood.

Minty wood.

From Madras.

Poplar-leaved *Hibiscus*, or Tulip-tree, Gengaramin kurra, Paris kajhar (old wood), Porsum marum (*Hibiscus populneus*).

2. Pagoda wood.

Palmyrah wood, Thattee kurra, Tar, Panung kutta (*Borassus flabelliformis*).

Red saunders wood, Chandanum Chander soorkh, Segapoo chandanum (*Pterocarpus santalinus*).

Jackwood, Palan samoc, Pinmass, Palan marum (*Butea frondosa*).

Guava wood, Jamakurra. 4. Jam. 5. Goaya khutai (*Psidium pyrifera*).

Play wood. 3. Paula kurra, Palla, Paulai marum (*Mimusops hexandra*).

Veppaley wood, Palava renoo kurra, Dooheer kela kree, Veppalay marum (*Wrightia antidysenterica*).

Eledai wood, Raigoo kurra, Jungbe beer, Yelandai marum (*Zizyphus jujuba*).

Wood-apple, Valaga kurra, Koweet, Vella marum (*Feronia elephantum*).

Satin wood, Billa kurra. 4. Hill dhawra (*Swietenia chloroxylon*).

From Cuddapah.

Ebony wood, Tookee, Abnas, Kakatstee (*Diospyros ebenaster*).

Red saunders wood, Chandanum, Chanda soorkh, Segapoo chandanum (*Pterocarpus santalinus*).

Margosa wood, Vepa kurra, Neem, Vepum marum (*Melia Azadirachta*).

Acacia Arabica wood, Nalla tooma, Siah kekur, Karoo velum (*Acacia Arabica*).

Rusty Mimosa wood, Tella tooma, Keekursafaed (*Vil vilum, Mimosa ferruginea*).

Chindaga wood, Chindaca, Soorjsiah, Katoo valay.

Ash-coloured Mimosa wood, Vellatorroo, Wardil vidatil (*Mimosa cinerea*).

Yeumaddy wood, Yeumaddy, Eumaddee, Eumuddee.

Saul wood, Yepai, Yepa aussenee (*Shorea robusta*).  
 Bassia wood, Yepa, Mohe'ka jar, Yelloopai (*Bassia longifolia*).  
 Red wood, Somee, Some'ka ther, Semmarum (*Swietenia febrifuga*).  
 Podo wood, Poda. 4. Pallas.  
 Woodooga, 4. Akola (*Alangium hexapetalum*).  
 Cassia wood, Rela, Amltas, Kondee (*Cassia fistula*).  
 Marundum wood, Muddee, Jungle kameng, Maroodum (*Terminalia alata*).  
 Muddee wood, Muddee. 4. Muddee (*Terminalia alata*).  
 Kondapala wood, Konda pala. 4. Khernee kee lakree.  
 2. Yerra polhee. 3. Nulla polhee. 4. Sagharee kala kree.  
 Bel wood, Mareadoo, Bel phal, Viloo marum (*Eggle Marmelos*).  
 2. Nulla baloosoo, Nulla baloosoo, Burra munja (*Canthium parviflorum*).  
 Jujuba, 2nd sort, Pala raigoo, Dordhea beer, Yelandri (*Zizyphus jujuba*).  
 2. Jany. 3. Jance. 4. Janee.  
 2. Neroodee, 2nd sort. 3. Chinna neroodee. 4. Neroodee.  
 2. Billoo, or satin wood. 3. Billoo. 4. Hill dawra (*Chloroxylon Swietenia*).  
 2. Konda erookee. 3. Koonda erookee. 4. Jungly goriei.  
 2. Muskaka jhar. 4. Muske'ka thar.  
 Indian dammer wood, Googlam, Ghooglat, Koon-gillium (*Chloroxylon dupada*).  
 Rose-apple wood, No. 1. Pedda nerooodoo, Burra jamoon, Peroo naga (*Eugenia jambolana*).  
 Rose-apple wood, No. 1. Sunna nerooodoo, Pae jamoon, Siroo naga (*Eugenia jambolana*).  
 Yalama wood, Yelama. 4. Dhawra.  
 Jujube wood, No. 1. Pedda raigoo. 4. Sooa beer (*Jujube, Zizyphus jujuba*).  
 Mooshtee, Mooshtee, Bachla, Moottee (*Strychnos nux vomica*).  
 Myrobalan chebulic, Karaka, kharurua, kadookae (*Terminalia chebula*).  
 Peah, saul, or yengasee. 3. Yagasee. 4. Peah saul.  
 Mahul wood. 4. Mohul.  
 Dhourah wood. 3. Dhowar.  
 Swam wood. 3. Swamoo kurra.

From Hill Tracts of Orissa.

2. Kendoo manjaw, or Abhes. Ebony.  
 Bundum wood. 3. Bandanum.  
 Kungrah wood.  
 Species of ebony, called Toomekachava. 3. Toomekachava kurra. 5. Kakatatee (*Diospyros ebenaster*).  
 Sissoo wood. 3. Yekerechava kurra. 4. Seessoo (*Dalbergia Sissoo*).  
 Dammer wood. 3. Googlama kurra (*Vatica*).  
 Panevapah wood, or red wood. 3. Maha nambo.  
 Goomoodoo wood. 3. Goomoodoo kurra.  
 Tadah wood. 3. Tadda kurra. 5. Kakatatee.  
 Somedah wood, Somida kurra. 4. Somida (*Swietenia febrifuga*).

Yegash wood. 3. Yegassee kurra, Peah saloo. 5. Vengay marum (*Pterocarpus marsupium*).  
 Bokkum wood; a die used mostly in making goolal (*Casalpinia sappan*).

From Cuddapah.

Red saunders wood. Chendanum, Chanda soorkh (Segapoo chandanum). (*Pterocarpus Santalinus*).  
 Tamarind wood, Chinta kuna, Nulee, Pooley marum (*Tamarindus Indica*).  
 Erythroxyton, Deva daree, Deo dharee, Deva tharum (*Erythroxyton areolatum*).  
 Vadasa, Vadessa. 4. Warsa.  
 Pedda jany, Pidda jance. 4. Buree jance.  
 Checkrane, Chickrane, Checkrane, Seekram.  
 3. Sunna ereekce, Chotee gonee, Sina naree vellam (*Cordia myxa*).  
 3. Ooroo pereekce, Sahree gonei, Peroo nanee vellam, (*Cordia*).

Black polkee, Nulla polkee. 4. Siáh polkee.  
 White polkee, Tella polkee. 4. Suffaid polkee.  
 Nameluddoojoo, Nemeo ladaojoo. 4. Jungle shaumbaloo.

Glomerous fig-tree, Medee, Gol leer, Attee marum (*Ficus glomerata*).

Poplar-leaved fig-tree, Ravee, Peepal, Arasa (*Ficus religiosa*).

Wild poplar-leaved fig-tree, Konda ravee, Jungle Peepul, Kat arasin.

Gopee, Gopee. 4. Gopee.

Emblie myrobalan, Oosarica, Amlah, Toopoo nellce (*Phyllanthus Emblica*).

Black emblie myrobalan, Nulla oosarica, Siah amlah, Neelee kadambo ( *Phyllanthus Emblica* ).

Bunka thada, Bunka thada, Baktra.

Rudra kadapa, Rudra Cuddapah, Roodra kurpah.

But cadapa, Buttoo Cuddapah, But kurpa.

Keernee, Keernee. 4. Khernee.

Duntha, Duntha. 4. Bekul.

Waved-leaved fig-tree, Joovee, Jovee, Kall alun (*Ficus infectoria*).

Vangueria spinosa, Pedda munga. 4. Bangaree keelakree (*Vangueria spinosa*).

Sarapappoo, Chara, Cheronjee kaghar sarai.

Soonkasoola, Soonkesooloo, Sunkesar kel akree, Vadee narainin.

Rusty soap nut, Koopoodoo, Reeh, Manee poongum (*Sapindus rubiginosa*).

Woody Dalbergia, Kanooga, Kuny, Poongum (*Dalbergia arborea*).

Thandra, Tandra, Tandra, Tance (*Terminalia bellerica*).

Elephant, or wood-apple, Veluga kurra, Koweet vella marum (*Feronia elephantum*).

Wild wood-apple, Konda vallaga, Jungle Koweet Kaloo Vellam (*Feronia elephantum*).

Narva, Narava. 4. Nawikelahree.

Pedda tapasee, Pidda tapasee. 4. Barea tapasee.

Beekee, Bikee. 4. Bikkee.

Jergubee, 3 sorts, Raigoo, Jungle beer, Yelam dai (*Jujube Zizyphus jujuba*).

Palavardnee, or Relay wood, Palava renoo, Doro heci kelakree, Veppallai (*Wrightia antidysenterica*).

Auray, Aree. 4. Aree.

Goothee, Goothee. 4. Gootheeree.

Corivee, Korivee, Korvee.

Mimosa sami, Jammee, Jaumbee, Vannee, Mimosa suma.

Pedda neerooddee, Pidda neeroodee, Burra neeroodee.

Clearing-nut tree, Chilla ginga, Chill binjore Naumbore naronbal, Taitan (*Strychnos potatorum*).

Kurre pakoo, Kurie pah, Kurré ripin (*Bergera Kenigii*).

Wild mango, Konda marindee, Jungle arm, Katoo maitlarum (*Spondias mangifera*).

3. Nara mamaidee. 4. Jungle rai and Dorrake waste (*Tetranthera monopetala*).

Poplar-leaved Hibiscus, or Tulip-tree, Gengaramin kurra, Paris kajhar (young wood), Poomsun marum (*Hibiscus populneus*).

From Northern Circars.

Goompana wood. 3. Goompana kurra (*Odina wodier*).  
 Ganara wood. 2. Ganara kurra. 3. Ganaroo kurra.

Wood-apple wood, Valaga kurra, Krowcet, Vella marum (*Feronia elephantum*).

Nulla muddi wood, Nulla muddi kurra. 5. Caroo maroodum (*Pentaptera tomentosa*).

Tella muddi wood, Tella muddi kurra, Vel maroodum marum (*Pentaptera glabra*).

Tangada wood, Tangadu kurra. 5. Auvarai marum (*Cassia auriculata*).

Paya wood. 3. Paya kurra.

Annen wood, Annen kurra.

Togaru wood, Togara kurra (*Morinda citrifolia*).

Red dye wood, 1st sort, Vizianagram Zeminary.

Red dye wood, 2nd sort. Ditto.

Boorooaga wood, Buruga kurra (*Bombax Malabaricum* or *heptaphyllum*).



Induga wood, Induga kurra. 5. *Thaethan marum* (*Strychnos potatorum*).  
 Nuckaroo wood, Nukkera kurra (*Cordia myxa*).  
 Tabica wood, Tolica kurra.  
 Tellovoolemara wood. 3. Tellovoolemara kurra.  
 Nullavoolemara wood, Nullaveloomara kurra (*Diospyros chloroxyylon*).  
 Vulture wood, Vulture kurra (*Mimosa cinerea*).  
 Bodda wood, Bodda kurra (*Ficus racemosa*).  
 Voodaga wood.  
 Lolooga wood, Lolooga kurra (*Pterospermum heynei*).  
 Gungarane wood, Gungarane kurra. 5. Poo varasa marum (*Thespesia populnea*).  
 Aguste wood (*Eschynomene grandiflora*).  
 Bandita wood, Bandita kurra (*Erythrina Indica*).  
 Soap-nut, or Koonkoodoo wood, Koonkoodoo kurra (*Sapindus emarginatus*).  
 Camoonya wood, Kumooga marum.  
 Doduga wood.  
 Cumba wood, Cumbakurra.  
 Goomoodoo wood, Goomoodoo kurra.  
 Unkoodoo wood, Unkoodoo kurra.  
 Undooroo wood, Undooroo kurra.  
 Iscarawsee wood, Iscarawsee kurra.  
 Ghantha wood, Ghantha kurra.

From Coimbatore.

Black wood. 5. Irrooppottoo marum (*Dalbergia latifolia*).  
 Vangay wood. 3. Vana kurra (*Pterocarpus marsupium*).  
 Curry murdah wood. 5. Karai maroodoo marum (*Terminalia glabra*).  
 Sadachoor, or Thadasoo wood. 5. Sadaichee marum (*Grewia tiliaefolia*).  
 Purrambay wood. 5. Parumbai marum (*Prosopis spiciagera*).  
 Vadu coornie wood. 5. Vadungoorany marum (*Bignonia xylocarpa*).  
 Toarattie wood, Toaratie marum, *Capparis divaricata*. (*Casuarina equestifolia*).  
 Neer cadumbay wood, Neer cadumbai marum (*Nauclea parvijlora*).  
 Munja cadumbay wood. 5. Manjull cadumbai marum (*Nauclea cordifolia*).  
 Woonga wood. 5. Woonga marum (*Acacia amara*).  
 Currengally wood. 5. Caroongaly marum (*Acacia Sundra*).  
 Pinnay wood. 3. Ponna kurra. 5. Pinnai marum (*Dillenia pentagyna*).  
 Pilla murdoo wood. 5. Pilla maroodoo (*Terminalia chebula*).  
 Ugay wood, Ooku marum (*Salvadora persica*).  
 Curry vangay wood. 5. Caroo vangai marum (*Acacia odoratissima*).  
 Vel vaila wood. 5. Vel Velan marum (*Acacia leucophlœa*).  
 Nunjoonda wood. 5. Nunjoonda marum (*Balanites Ægyptiaca*).  
 Allum vildoo wood. 5. Allum vildoo (*Ficus Indica*).  
 Vellay toarattie wood, Vellai toarattie (*Capparis grandis*).  
 Mavoolinga wood, Mavoolinga marum (*Cratœva Roxburghii*).  
 Erovao wood, Iroovao wood marum (*Inga xylocarpa*).  
 Corkapully wood, Cadookapooly marum (*Inga dulcis*).  
 Ayah wood. 5. Ayah marum (*Ulmus integrifolia*).  
 Kalli milk hedge wood. 5. Kalli (*Euphorbia tirucalli*).  
 Peru wood. 3. Pethawkoo kurra. 5. Peroo marum (*Ailanthus excelsa*).  
 Yellah culley wood. 5. Yellai kullie (*Euphorbia nerifolia*).  
 Putchalay wood. 5. Putchalai marum (*Dalbergia paniculata*).  
 Eetcha wood, or Date wood. 5. Eetcha marum (*Phœnix sylvestris*).  
 Cocoa-nut wood, Golbaree kurra, Narel, Thenna marum (*Cocos nucifera*).  
 Moorook wood. 5. Moorookoo marum (*Erythrina Indica*).

Paroonjoly wood. 5. Paroonjoly marum (*Hymenodictyon utile*).  
 Moolloo vangay wood, Moolloo vanai marum (*Briedelia spinosa*).  
 Vellay naga wood. 3. Tella nareedoo kurra. 5. Vella naga marum (*Conocarpus latifolia*).  
 Eichie wood. 5. Eichie marum (*Ficus tsiela*).  
 Nawel wood. 3. Naredon kurra. 5. Nawel marum (*Eugenia caryophyllifolium*).  
 Woodoogoo wood. 5. Woodoogoo marum (*Chrytea collina*).  
 Acacia. Areca-nut, or Camoogoo wood. 5. Camoogoo marum.  
 Anny curry wood. 5. Annaikarai marum (*Odina wodier*).  
 Kurkutta wood. 5. Kurkutta marum (*Zizyphus yendai*).  
 Vel vangay wood. 5. Vel vangay marum (*Acacia speciosa* or *flezuosa*).  
 Vellay murdah wood, Vellai murdoo (*Terminalia berryi*).  
 Munjay pavutay wood. 5. Munja pavuttai (*Morinda citrifolia*).

Furniture woods grown in Pinang or Prince of Wales Island, sent by Singapore Committee:—Siam wood. Ebony. Wild Durian. Uncertain. Angsena wood. Guava wood. Kamuning. Senna Baymah or Angsena. Mirlimoh, two kinds. Baloh. Baloh Bunga. Root of Betelnut tree. Root of Cocoanut tree. Clove wood. Root of Eboeh tree. Timbusu. Siam wood. Timbusu. Baloh. Baloh Bungah. Ranggas. Pinang wood. Kulim. Baloh. Ibool wood.

Lingoa wood, or the Amboyna wood of commerce, from Ceram in the Moluccas. It was imported in considerable quantities into Great Britain during the period in which the Moluccas were British possessions. This wood, which is very durable and capable of a high polish, is abundant at Ceram, New Guinea, and throughout the Molucca Seas. It can be obtained in any quantity if the precaution is taken of ordering it during the previous trading season. The Kayu Buka of commerce is the knarled excrescence of this tree. Presented by Messrs. Almeida and Sons, of Singapore, the importers.

Lingoa wood, from Ceram. A circular slab, 6 feet 7 inches in diameter. These large circular slabs are obtained by taking advantage of the spurs which project from the base of the trunk, as the tree itself has not sufficient diameter to furnish such wide slabs. They are occasionally met with as large as 9 feet, but the usual size is from 4 to 6 feet. Presented by Messrs. Almeida and Sons, of Singapore.

Kayu Buka, from the Moluccas. This wood is obtained from the knotty excrescences which are found on the stems of the Lingoa tree. It is brought to Singapore by the Eastern traders from Ceram, Arru and New Guinea, and is sold by weight. It is much esteemed as a fancy wood.

Useful woods of the Malay Peninsula:—Bintangor wood. In general use for planks, masts, and spars; in fact it holds the same position in the Straits as the pine in America. It exists in the greatest abundance around Singapore, and is exported to the Mauritius and to California:—Kledang. Biliang. Changis. Klat. Timbusu. Kayu Brompong. Angsanah. Tampinis. Tampang. Kranji. Slumar. Simpoh Bukit. Krantai. Kamuning. Simpoh Ryah. Merbow. Medansi Miniak. Ditto, Buah Yeah. Ditto, Konit. Ditto, Kitanahan. Ditto, Tandoh. Bilion Wangi. Jambu-Ayer-Utan. Peragah. Kayu Arang. Leban. Ranggas. Bras-bras.

Glam. The glam tree furnishes a paper-like bark used in caulking the seams of vessels.

Poolai wood used as floats for fishing nets.  
 Sandal wood. The island of Timor is the only place which produces it in the Archipelago in any quantity.

Sapan wood, from Siam and the Philippine Islands. Furnishes a red dye, and is, in fact, the logwood of the Archipelago. Exported in large quantities to Europe.

The growth of Singapore:—Knee timber. Merbow wood. Seventy specimens of timber.

Canes, reeds, and grasses, from Singapore Committee :—  
Cane walking sticks from Malacca and Sumatra, as cut from the jungle previous to being subjected to the process of smoking, which gives them their rich brown tint.

Ditto six varieties thereof.

Canes and sticks of kinds from Cochin.

Bamboos from the jungles in the vicinity of Calcutta.

Bamboos from the Tenasserim provinces :—*Bambusa spec.*, *Bambusa gigantea*, *Bambusa stricta*, *Bambusa spec.*, *Calamus angustifolia*, *Calamus fasciculatas*, and five other species.

*Calamus rotang*, used in making rattan chairs, &c.

*Saccharum sp.*, used by natives instead of quills to write with.

*Arundo karka*, used in preparing hookah snakes.

*Cyperus tegetum*, employed in making mats.

*Khus-khus* or scented grass, from Ulwar in the states of Rajpootanah.

*Phrynium dichotomum*, Settulputtee, of which the finest mats are made; grown in the district of Chittagong.

(I.) *Miscellaneous Substances.—Vegetable Kingdom.*

Mishmee bih, Bih booteah, poisons for poisoning arrows, from Bengal.

Twigs, used as tooth brushes (*Trophis aspera*), from Bengal.

*Sapindus emarginatus*, Soap nut, from Madras.

Soap nut, Kunkude kaya, from Vizagapatam.

Another kind of soap nut (*Mimosa abstergens*), from Calicut and Madras.

Clearing nut (*Strychnos potatorum*), from Madras.

*Animal Substances used as Food, or in the preparation of Food.*

Preserved hump of the East Indian ox, from India. (J. Clarkson, 171 Strand.)

Fish paste, two jars, from Arrakan.

Sharks' fins (punk), from Rao of Cutch, Arrakan, Tenasserim, Malacca, and Manilla, used in China as an article of food.

Shark's fins (Cutch). These are exported to Bombay for re-exportation to China.

Shark's fins (Bombay). What are exported from Bombay are chiefly imported from other countries.

Isinglass, prepared by Mr. Scott, of the Hon. East India Company's Dispensary, presented by Dr. McClelland.

Fish maws, isinglass (ohola), from Rao of Cutch, Tenasserim, Sumatra. Fish maws from Cutch are exported to Bombay for re-exportation to China.

Fish maws (Bombay). What are exported from Bombay are chiefly imported from other countries.

Edible birds' nests, 1st quality, from Sambawa, east of Java, and from Java. The nests of the *Hirundo esculentia*, collected chiefly in the limestone caverns of the south coast of Java, and the islands of the eastward as far as Arru, near New Guinea; highly esteemed for their supposed nutritious and restorative properties.—From Singapore.

Edible birds' nests, 2nd quality, from Borneo; 3rd quality, from Borneo and from Tenasserim.

Trepang, or edible sea slug (*Beche de Mer*), from Borneo. Collected in large quantities throughout the Indian Archipelago, especially among the eastern islands, for the China market.—From Singapore.

The other varieties are *Lotong*, *Buangkulil*, and *Pandang*.

Honey, from Beerbhoom and the Cossya Hills.

*Animal Substances used in Medicine and in the Arts.*

Musk, in pod and in grains; Nepal pods in a bamboo bottle, from Assam.

Musk, ambergris, and civit, are usually supplied to Bombay, from Aden.

Blistering beetle (*Mylabris cichoriae*; *Meloe trianthemae*). Elytra, or beetle wings. From Dr. C. Huffnagle.

The beetle. The elytra, or beetle wings. Garlands made from the elytra. Muslin, as ornamented with the elytra.

*Wool, Hair, Bristles, and Whalebone.*

Camel's wool, and camel's hair cloth.

Sheep's wool (Sindh). A small specimen only from Sindh was supplied. The piece of brown woollen cloth is stated to have been made from it.

Wool, from Rao of Cutch. About a sixteenth part of the wool produced in Cutch is stated to be used for home consumption, and the rest exported to Bombay.

White and black twisted and untwisted wool, from Rajah of Bickaneer.

Wool (Assan and Chusmas wool), from Rajah of Jessmere.

One maund of sheep's wool, Bengal.

Specimens of sheep's wool and goats' down, from Ladak, obtained by Lieut. Strachey, B.E.

Wool (Bal), Jang-bal (Nakpo), black, Highland wool.

Yumibu (Highland), lambs' wool.

Rong-bal (Karpö), white, valley wool.

Jung-bal (Karpö), white, Highland wool.

Goats' down; Tibetan (Lena and Kulu), Turkish (Tibbit), Persian (Kashm), and Hindostanee (Pashm).

Lena karpö (Kalchak), white goats' down, picked.

Lena nakpo (Kalchak), dark goats' down, picked.

Tibbit Yarkhendi, goats' down from Yarkend; Tibbit Khotani, goats' down from Khote; Tibbit Turfani, goats' down from Turfan.—Provinces of Chinese Turkey.

Kulu, yaks' down.

Tsos-kul, down of the "tsos" antelope, and a piece of the animal's skin.

Wild boar, elephant, and porcupine bristles.—Madras.

*Silk from the Silk-worm, and other species in India.*

4480 cocoons, from Bhagulpore.

Areah cocoons, from Assam.

Raw tusseh silk (*Saturnia mylitta*), from Bhagulpore.

Raw silk, 1½ seers, and 1 skein wild silk, from Arrakan.

Mazankoree (thread) lata, and Areah lata, from Assam.

Raw silk, Areah silk, Moongha silk, 12 kinds, from Assam.

Coloured raw silk, from vicinity of Calcutta.

Raw silk, from Azingurh, Nepal, and Mysore.

*Tussur (or Tusseh), Eri, Moonga, and Pat Silk.*

*Saturnia Mylitta (Tussur)*, feeds upon the *Terminalia catappa* and *Zizyphus jujuba*. Eggs and caterpillar; cocoons; silk; cocoons from which the moth has escaped; the moth, male and female; and one piece of Tussur cloth, made at Midnapore.

*Bombyx Saturnia (Moonga)*, feeds upon the *Zizyphus jujuba* and *Terminalia catappa*. Eggs and caterpillar; cocoons; silk; moth, male and female; and one piece of Moonga cloth, made in Assam.

*Phalena Cynthia (Eri)*, feeds upon the *Ricinus communis*. Eggs and caterpillar; cocoons; silk; moth, male and female; and one piece of Eri cloth, made in Assam.

*Bombyx Mori (Pat)*, feeds upon the mulberry. Eggs and caterpillar; cocoons; silk; moth, male and female; and one piece of cloth, made in Assam.

A specimen of the *Saturnia Atlas*, and coloured drawings of the *Terminalia catappa*, *Zizyphus jujuba*, and *Ricinus communis*. The property of Dr. Charles Huffnagle.

Raw silk :—Four varieties from Messrs. J. and R. Watson's manufacture, Surdah filature. The silk has been obtained from Bengallee or Desee worms, which feed on mulberry leaves or toot plant. Four varieties from Mr. W. Macnair's manufacture in the Joradah filature. The silk has been obtained from Nistry and Desee worms, feeding on mulberry leaves; it is the produce of the November bund, and made from small yellow cocoons.—Assorted in a case and contributed by D. Jardine, Esq., of Calcutta.

Raw silk :—Two varieties from Rakhaldoss Mookerjee's manufacture, Cossim bazar filature. The silk has been obtained from Nistry worms, which feed on mulberry leaves. Two varieties from Bahary Laul, Mookerjee's manufacture, Cossim bazar filature. The silk has been obtained from Nistry worms feeding on mulberry leaves.

Two varieties from Degumber Mittre's manufacture, Cosim bazar filature. The silk has been obtained from Bengallee or Dese worms, which are bred and reared from the beginning of October to the middle or close of November, and are fed on the tender shoots of the mulberry plants. One variety from C. R. Jennings, Esq.'s manufacture, Galimfore filature. The silk is obtained from Bengallee or Dese worms, which feed on mulberry plants or *Toot pant*; the produce and colour of the cocoons are generally better from mulberry grown in strong clay soil.—Asserted in a case, and contributed by D. Jardine, Esq., of Calcutta.

Raw silk:—Manufactured by Messrs. V. and S. M. Vardon, Soogapoor, of eight cocoons of the rainy bund.—From the Calcutta list.

#### *Feathers, Down, Fur, and Skins.*

White and black ostrich feathers, from Aden.  
Manufactures of feathers by the natives, raw feathers, boas, tippets, artificial flowers, from Dr. C. Huffnagle.  
Boas, tippets, victorines, &c., from the down of the young *Ciconia argala*, collected at Commercolly.  
Cranes' white feathers, from Arrakan and Tenasserim.  
Tails of the yak, or *Bos grunnicus*.  
Chouries, from Arrakan.  
Black tiger skins, from Madras, Calicut.  
Antelope skins, from Rajah of Patteala.  
2 leopard skins, 3 tiger skins, 1 spotted deer skin, 1 white or tawed deer skin, 2 favns, from Bengal, from G. C. Cheap, Esq.  
100 Bengal deer skins, from Patna.  
50 buffalo hides, 100 goat skins, 50 cow hides, from Bengal.  
Two squirrels and two lizards.  
Deer skin, otter skin, jowmalah skin, squirrel skin, kooteah skin, from Assam—Baboo Deenanath.  
Brown bear skin.  
2 pieces of fish skins, 8 specimens of kingfishers' skins, from Arrakan.  
Raw and tanned skins of elk, buffalo, bull, tiger, cheeta, wild cat, goat, sheep, deer, elephant, bison.—Madras.

#### *Bone, Horn, Hoofs, Ivory, &c.*

Horn tips. Deer and buffalo horns, with skulls and without. Wild Mython cow's head, complete. Mountain sheep's head. Takin's head. Singphoo cow's head, Mishmee. Singphoo cows' heads, without skulls, three pairs.—Assam, Captain Smith and Mr. W. S. Hudson.  
Two buffalo horns.—Tenasserim Provinces.  
Buffalo and deer horns, from interior. Rhinoceros horns, from Zanzibar. These are imported at Bombay, from the eastern coast of Africa, Zanzibar, and the Somali coast; they are then re-exported to China for making cups and ornaments. The one sent is the double horn of the *Rhinoceros Africanus*.  
Two nielgai horns, and rhinoceros horn.—Moulmein, Tenasserim Provinces.  
Horns of bison, buffalo, elk, antelope, deer (one pair).—Madras.

#### *Scientific Names of Horns and Skins from India.*

The gour (*Bos [bibos] cavifrons*), Hodgson; (*Bos gourus*), Hamilton Smith.  
The arnee (*Bos [bubalus] arna*), Hodgson.  
The bárah sinha (*Cervus [bucevurus] elaphoides*), Hodgson; (*Cervus duvaucellii*), G. Cuvier.  
The sámber (*Cervus [russa] hippelaphus*), Cuvier.  
The kaker, or barking deer (*Cervus [muntjacus] vaginalis*), Boddart.  
The axis (*Axis maculata*).  
The thar (*Capricornis bubalina*), Hodgson.  
The hog deer (*Axis porcinus*), Zimmerman.  
The rassor, or roosh (*Ovis polii*), Blyth.  
Flying squirrel (*Saurus petaurista*), Palls.  
Takin (*Bridorcas saziocola*), Hodgson.  
Elephants' tusks.—Tenasserim Provinces.  
Elephant's tusk.—Nepal.  
Elephants' tusks, and hippopotamus' teeth, Somali Coast.—Aden.

Elephant's tusks.—Madras.

Bundle of Mergui tortoise-shell.

Shell of the hawk's-bill turtle, Sulu Islands. The tortoise-shell of commerce, from Singapore.

Mother-of-pearl shell, Arru Islands and Sulu.

#### *Pearls, &c.*

349 seed pearls.—Kurrachee, *viâ* Scind and Bombay.  
These seed pearls are from the fishing at Kurrachee. They are small and of little value, except with those who esteem them as a medicine, to wit, the Persians and some of the Hakeems of India.

Pearl-oysters were not procured at Kurrachee before the times of Meer Moorad Ali Khan. They were obtained in this manner (Bombay Report):—

The oysters come up to the shore at high water. When the tide fell, there they remained, and Coolies were employed for the occasion; who gathered them up, put them in boats, and landed them all at Keeamaree Point. There the shells were broken, and the pearls extracted, under the orders of the contractors, who paid the Tulpore Government a yearly sum for the pearl contract; at first, only 500 rupees per annum were paid, but after a time, 40,000 rupees were given for the same period. Now, even Government sell yearly the right of sifting the shells in search of any pearls that may still remain.

Fresh-water pearls, with their shells.—Moorshedabad.

27 Mergui pearls.

Bundle of pearl oyster-shells.—Tenasserim.

Shells from Zanzibar, *viâ* Bombay.

Bombay shells (so called in India): these are imported from Zanzibar in large quantities, and are stated to be exported to England, or to the Mediterranean for cameos. The specimens sent are those of *Cassis rufa*.

Cowries, cyprei, imported from the Maldiv Islands, and current as money in India.

#### *Oils, Tallow, Wax, and Lard.*

Bengal tallow.

Bees'-wax, 13 seers 12 chek.—Bhagulpore.

Bees'-wax, three varieties, from Borneo.

The bee of the Indian Archipelago does not make its nest in hives, as in Europe, but suspends it from the branch of a tree, in which position they may be seen forming masses of considerable bulk. Certain trees become favourites, and are selected by them, year after year, for many generations, although often disturbed by the taking of their nests. These trees become private property among the Eastern tribes, and are handed down from father to son.

#### *Glue, Isinglass, and Gelatine.*

Isinglass from *Polynemus plebeius*, v. supra.

*Polynemus plebeius*; the fish yielding Bengal isinglass, from Dr. Walker.

Fish, called chuppa, yielding isinglass.—Arrakan.

#### *Lac.*

Glass case, containing illustrations of the process of lac manufactures. The lac insect, young. Stick-lac, seed-lac, lac dye, shell-lac, sealing-wax, shell-lac ornaments.—Dr. C. Huffnagle.

Stick-lac, and a kind of lac.—Calcutta.

Seed-lac, one maund.—Bhagulpore.

Shell-lac, of the kind called bala, and of the kind called chanuk.—Beerbhoom.

Lac from off the Peepul-tree (*Ficus religiosa*); and off the ban, or Indian fig-tree (*Ficus indica*); and off the bere, or *Zizyphus jujuba*.

Stick-lac, on twigs of *Mimosa abstergens* and *Ficus religiosa*.—Malabar, *viâ* Bombay.

Stick lac: this is imported at Bombay, from Sindh; also brought from the Southern Mahratha country, and most parts of Western India, for re-exportation to China and England.

Gum-lac.—Singapore.

Raw lac.—Ganjam.

Stick-lac and seed-lac.—Bengal.

Lac dye, 1 maund 10 seers.—Bengal.

MISCELLANEOUS COLLECTION of MINERAL, VEGETABLE, and ANIMAL SUBSTANCES useful in Medicine and the Arts, made by Dr. ROYLE, in the Bazaars of the Bengal Presidency; with some additions from Dr. FALCONER (F.), obtained in Cashmere, and others from Dr. STOCKS (H.), procured by him in the Bazaars of Scinde. The collection is interesting, as containing most of the useful products of India, besides enabling us to identify many of the substances which were known to the Arabs as well as to the Greeks, as the author has endeavoured to show in his works, "Essay on the Antiquity of Hindoo Medicine," and "Illustrations of Himalayan Botany."

## ROOTS.

| No. | —                                 | Synonyms.                  | Places whence Obtained.      | Scientific Names, &c.                         |
|-----|-----------------------------------|----------------------------|------------------------------|-----------------------------------------------|
| 1   | Aboo Khulsa . . . . .             | Rutunjot . . . . .         | Mooltan . . . . .            | Alkanet?                                      |
| 2   |                                   | Rutunjot . . . . .         |                              | Lithospermum?                                 |
| 3   | Aboo Kanus . . . . .              |                            | Roum.                        |                                               |
| 4   | Atees butees . . . . .            |                            | Kedarkanta . . . . .         | Aconitum heterophyllum.                       |
| 5   |                                   |                            | Guzerat.                     |                                               |
| 6   |                                   | Bish, 2nd . . . . .        | Caubul.                      |                                               |
| 7   | Atees, F. . . . .                 | Tirayamen . . . . .        | Kedarkanta.                  |                                               |
| 8   | Uzkheer . . . . .                 |                            | India . . . . .              | Andropogon, camel's hay.                      |
| 9   | Azkhar, St. Izkeer.               |                            |                              |                                               |
| 10  | Arkuree? Arkuree . . . . .        | "Ree," or "Maroee"         | Scinde.                      |                                               |
| 11  | Urloo . . . . .                   | Tat burunga . . . . .      | India, Dehli . . . . .       | Bignonia indica.                              |
| 12  | Asaroon . . . . .                 | Tuggur . . . . .           | Hills . . . . .              | Viola sp., substitute for Asarum<br>Europeum. |
| 13  | Tugur F. substitute.              |                            |                              |                                               |
| 14  | Afeemedoon . . . . .              |                            | Dehli, Surat . . . . .       | Epithymum.                                    |
| 15  | Iskeel . . . . .                  |                            | India . . . . .              | Scilla indica.                                |
| 16  | Asgund . . . . .                  | Nagouree . . . . .         | India . . . . .              | Physalis flexuosa.                            |
| 17  | Asgund . . . . .                  | Hatrass . . . . .          | Mirzapore.                   |                                               |
| 18  | Akurkura . . . . .                |                            | Dehli . . . . .              | Anthemis pyrethrum.                           |
| 19  | Amba huldee . . . . .             |                            | Arabia . . . . .             | Curcuma.                                      |
| 20  | Urnduryan . . . . .               |                            | Arabia.                      |                                               |
| 21  | Anarooli . . . . .                |                            |                              |                                               |
| 22  | Unteleh Souda . . . . .           | Nirbisee dukhune . . . . . | Umritseer . . . . .          | An Aconitum?                                  |
| 23  | Unteleh Souda . . . . .           |                            |                              | Aconitum Ferox.                               |
| 24  | Unjbar roomee . . . . .           |                            |                              | Bistort or Snake-wood.                        |
| 25  | Unjbar, St. . . . .               |                            |                              |                                               |
| 26  | Unjbar . . . . .                  |                            | Cashmere?                    |                                               |
| 27  | Aveel Kusmeere . . . . .          |                            |                              |                                               |
| 28  | Aal, F. . . . .                   |                            |                              | Morinda citrifolia.                           |
| 29  | Ayrsean, St. . . . .              |                            |                              | Orris-root.                                   |
| 30  | Barahee Kund . . . . .            |                            | Caubul.                      |                                               |
| 31  | Beeja Sar, F. . . . .             |                            |                              | Acorus Calamus.                               |
| 32  | Bidaree Kund . . . . .            | Sural cheep . . . . .      | Gunga ke kadir . . . . .     | Hedysarum tuberosum.                          |
| 33  | Bidhara . . . . .                 |                            |                              |                                               |
| 34  | Burkuk Shirazee . . . . .         |                            | Surat.                       |                                               |
| 35  | Bekh Atrilal . . . . .            |                            |                              |                                               |
| 36  | Burmooloo? . . . . .              |                            |                              |                                               |
| 37  | Bisfaij . . . . .                 |                            | Caubul . . . . .             | Polypodii, sp.                                |
| 38  | Bisfaij, F. . . . .               |                            | Caubul.                      |                                               |
| 39  | Biskhupra . . . . .               |                            | India . . . . .              | Trianthema pentandra.                         |
| 40  | Bilsekund . . . . .               |                            |                              |                                               |
| 41  | Bunufsha . . . . .                |                            | Cashmere and Hills . . . . . | Viola repens.                                 |
| 42  | Bozedan . . . . .                 |                            | Surat.                       |                                               |
| 43  | Buehmun soorhk . . . . .          |                            | Caubul.                      |                                               |
| 44  | Buehmun suffed . . . . .          |                            | Surat.                       |                                               |
| 45  | Buehmun suffed, F. . . . .        |                            | Iran.                        |                                               |
| 46  | Buehmun suffed, St. . . . .       | Dehli . . . . .            | Scinde . . . . .             | White Bahman.                                 |
| 47  | Buehmun suffed . . . . .          |                            | Bengal.                      |                                               |
| 48  | Bish . . . . .                    |                            |                              | Aconitum ferox.                               |
| 49  | Bish . . . . .                    | Kala koot . . . . .        | Umritseer.                   |                                               |
| 50  | Bish, 2nd specimen . . . . .      |                            | Peshawur.                    |                                               |
| 51  | Pukhan bed . . . . .              |                            | Himalayas . . . . .          | Saxifraga ligulata.                           |
| 52  | Pelijeree, F. . . . .             |                            |                              | Thalictrum.                                   |
| 53  | Pursoona . . . . .                |                            |                              |                                               |
| 54  | Pokhur mool . . . . .             |                            | Dehli, Guzerat, Umritseer.   |                                               |
| 55  | Pearanga . . . . .                |                            |                              |                                               |
| 56  | Tal moolie . . . . .              |                            |                              | Curculigo orchioides.                         |
| 57  | Toorbud . . . . .                 | Rusot . . . . .            | India . . . . .              | Convolvulus turpethum.                        |
| 58  | Mishmee Teeta . . . . .           |                            |                              | Coplis Teeta.                                 |
| 59  | Jalapa . . . . .                  |                            | Dehli Bazaar . . . . .       | Convolvulus Jalapa.                           |
| 60  | Jamghas . . . . .                 |                            | Surat via Dehli . . . . .    | An Polypodii sp.                              |
| 61  | Judwar . . . . .                  | Nirbisee, 2nd . . . . .    | Umritseer.                   |                                               |
| 62  | Judwar . . . . .                  |                            |                              |                                               |
| 63  | Judwar, St. . . . .               |                            |                              | Zedoary.                                      |
| 64  | Junteeana . . . . .               |                            | Caubul . . . . .             | Gentian.                                      |
| 65  | Junteeana 2nd . . . . .           |                            | Surat via Dehli.             |                                               |
| 66  | Chirya kund . . . . .             |                            | Cashmere via Dehli.          |                                               |
| 67  | Chob Cheenee . . . . .            |                            | Poorub . . . . .             | Smilax china.                                 |
| 68  | Chaya . . . . .                   |                            |                              |                                               |
| 69  | Chok . . . . .                    |                            | Umritseer . . . . .          | Orris-root sp.                                |
| 70  | Hunzil . . . . .                  |                            |                              | Cucumis colocynthis.                          |
| 71  | Khirkuk, substitute for . . . . . |                            |                              | Hellebore.                                    |
| 72  | Khus khus . . . . .               | Punnee . . . . .           | India . . . . .              | Andropogon muricatum.                         |
| 73  | Khunjuk, St. . . . .              |                            |                              |                                               |

| No. | —                                 | Synonyms.                    | Places whence Obtained.     | Scientific Names, &c.                  |
|-----|-----------------------------------|------------------------------|-----------------------------|----------------------------------------|
| 74  | Salep hindee.                     |                              |                             |                                        |
| 75  | Salep misree.                     |                              |                             |                                        |
| 76  | Salep misree, F. . . . .          |                              | Saharanpore . . . . .       | Eulophia campestris.                   |
| 77  | Salib misree . . . . .            | Khoosyut ool Salib . . . . . | Caubul . . . . .            | Orchideæ.                              |
| 78  | Khusyeet ool Salib, 2nd . . . . . | . . . . .                    | Poorub.                     |                                        |
| 79  | Kholinjan . . . . .               | . . . . .                    | Himalayas . . . . .         | Alpinia Galanga.                       |
| 80  | Dar huld . . . . .                | . . . . .                    | . . . . .                   | Berberis Asiatica.                     |
| 81  | Doorunaj Akrabee . . . . .        | Utees? . . . . .             | . . . . .                   | Doronicum pardalianches ?              |
| 82  | Dantun, F. . . . .                | Jumulgotta kejur . . . . .   | . . . . .                   | Croton Tiglium.                        |
| 83  | Doodhee . . . . .                 | . . . . .                    | . . . . .                   | Euphorbia tristes.                     |
| 84  | Doodhee . . . . .                 | . . . . .                    | . . . . .                   | Euphorbia tristes.                     |
| 85  | Rawa, St. . . . .                 | . . . . .                    | . . . . .                   | Prepared Turmeric.                     |
| 86  | Rawund . . . . .                  | . . . . .                    | Himalayas . . . . .         | Rheum Emodi.                           |
| 87  | Rewund Khutai . . . . .           | . . . . .                    | . . . . .                   | Rheum sp.                              |
| 88  | Rewund Chenee, F. . . . .         | . . . . .                    | Nujeebabad.                 |                                        |
| 89  | Rewund Chenee, St. . . . .        | . . . . .                    | . . . . .                   |                                        |
| 90  | Rataloo, F. . . . .               | . . . . .                    | . . . . .                   | Rheum Ribes Dioscorea.                 |
| 91  | Pesha Khutmee, F. . . . .         | . . . . .                    | . . . . .                   |                                        |
| 92  | Zurawund taveel . . . . .         | . . . . .                    | Cashmere. . . . .           | Aristolochia longa.                    |
| 93  | Zurawund gird or mood-ehruj.      | . . . . .                    | Cashmere. . . . .           | Aristolochia rotunda.                  |
| 94  | Zurawund Moodehruj.               |                              |                             |                                        |
| 95  | Zurunbad . . . . .                | Kuchoor . . . . .            | . . . . .                   | Curcuma Zerumbad.                      |
| 96  | Zurunbad.                         |                              |                             |                                        |
| 97  | Kuchoor, F. and St. . . . .       | Dot.                         |                             |                                        |
| 98  | Zunjbeel . . . . .                | South . . . . .              |                             | Zingiber officinale.                   |
| 99  | Ada . . . . .                     | . . . . .                    | Himalayas . . . . .         | Green ginger.                          |
| 100 | Salsa . . . . .                   | . . . . .                    | Surat.                      |                                        |
| 101 | Sutawur . . . . .                 | . . . . .                    | Nujjibabad . . . . .        | Asparagus ascendens.                   |
| 102 | Sutawur suffed. . . . .           | . . . . .                    | Dehli.                      |                                        |
| 103 | Suttee . . . . .                  | Kupoor kuchoor . . . . .     | Dehra and Khalsee . . . . . | Globba sidhouol.                       |
| 104 | Saad . . . . .                    | Motha . . . . .              | Guzerat . . . . .           | Cyperus rotundus?                      |
| 105 | Saad, 2nd . . . . .               | . . . . .                    | Dehli . . . . .             | Cyperus rotundus.                      |
| 106 | Cyperus, Saad . . . . .           | Nagur motha . . . . .        | . . . . .                   | Cyperus juncifolius?                   |
| 107 | Sunbul Balchur . . . . .          | Jatamansi . . . . .          | Himalayas . . . . .         | Nardostachys Jatamansi.                |
| 108 | Soombul? Sunpat?                  |                              |                             |                                        |
| 109 | Sorinjan shereen . . . . .        | . . . . .                    | Surat . . . . .             | Colchicum illyricum?                   |
| 110 | Sorinjan, F. . . . .              | . . . . .                    | Caubul.                     |                                        |
| 111 | Sorinjan tulkh . . . . .          | . . . . .                    | Saharanpore.                |                                        |
| 112 | Satheea, F. . . . .               | . . . . .                    | . . . . .                   | Liquorice Root.                        |
| 113 | Soos . . . . .                    | Mulethee . . . . .           | . . . . .                   | Orris Root.                            |
| 114 | Sosun . . . . .                   | Eersa . . . . .              | Caubul . . . . .            |                                        |
| 115 | Set Burwa, F. . . . .             |                              |                             |                                        |
| 116 | Serab, F. . . . .                 |                              |                             |                                        |
| 117 | Sheebabee . . . . .               | Jur oorad . . . . .          | Surat . . . . .             | Phaseolus Max. radiatus.               |
| 118 | Shakakel.                         |                              |                             |                                        |
| 119 | Shakakel misree . . . . .         | . . . . .                    | Egypt?                      |                                        |
| 120 | Gajur misree . . . . .            | . . . . .                    | Peshawur.                   |                                        |
| 121 | Shakakul . . . . .                | . . . . .                    | Cashmere.                   |                                        |
| 122 | Shakakul . . . . .                | . . . . .                    | Cashmere.                   |                                        |
| 123 | Shakakul . . . . .                | . . . . .                    | Cashmere.                   |                                        |
| 124 | Shuojun.                          |                              |                             |                                        |
| 125 | Shogun mentri.                    |                              |                             |                                        |
| 126 | Sheeturuj . . . . .               | Cheeta . . . . .             | . . . . .                   | Plumbago Zeylanica.                    |
| 127 | Songhia.                          |                              |                             |                                        |
| 128 | Turasees.                         |                              |                             |                                        |
| 129 | Akurkura. . . . .                 | Kurkura . . . . .            | Calcutta . . . . .          | Anthemis pyrethrum.                    |
| 130 | Aruk ool Sufr huldee . . . . .    | Jaola huldee . . . . .       | Poorub.                     |                                        |
| 131 | Aruk ool Sufr . . . . .           | . . . . .                    | . . . . .                   | Turmeric Curcuma longa.                |
| 132 | Umba huldee.                      |                              |                             |                                        |
| 133 | Umba huldee.                      |                              |                             |                                        |
| 134 | Huldee.                           |                              |                             |                                        |
| 135 | Huldee . . . . .                  | . . . . .                    | Bengal.                     | Curcuma species.                       |
| 136 | Huldee.                           |                              |                             |                                        |
| 137 | Puharee huldee.                   |                              |                             |                                        |
| 138 | Puharee huldee, F. . . . .        |                              |                             |                                        |
| 139 | Poombee huldee.                   |                              |                             |                                        |
| 140 | Moela huldee . . . . .            | . . . . .                    | Poorub.                     |                                        |
| 141 | Huldee.                           |                              |                             |                                        |
| 142 | Fawania . . . . .                 | Ood Salub . . . . .          | Arabia . . . . .            | Pœonia corallina.                      |
| 143 | Pipula Mool . . . . .             | Filfil moorbel . . . . .     | . . . . .                   | Piper longum.                          |
| 144 | Filfil moorbel . . . . .          | . . . . .                    | Poorub.                     |                                        |
| 145 | Fooh . . . . .                    | Munjeeth . . . . .           | . . . . .                   | Rubia Munjeet.                         |
| 146 | Munjeet . . . . .                 | . . . . .                    | Arabia . . . . .            | Rubia tinctorum.                       |
| 147 | Koot . . . . .                    | Costus of ancient . . . . .  | Cashmere . . . . .          | Aucklandia Costus, series of Falconer. |
| 148 | Koot, St. . . . .                 | . . . . .                    | . . . . .                   |                                        |
| 149 | Koot shereen.                     |                              |                             |                                        |
| 150 | Koot tulhh . . . . .              | . . . . .                    | Muritsur.                   |                                        |
| 151 | Koost? . . . . .                  | Poongee.                     |                             |                                        |
| 152 | Koolun . . . . .                  | . . . . .                    | Surat . . . . .             | Columba.                               |
| 153 | Kala bichwa . . . . .             | . . . . .                    | Lucknow . . . . .           | Polypodii sp.                          |
| 154 | Kamruj . . . . .                  | . . . . .                    | Poorub . . . . .            | Felix.                                 |
| 155 | Kana kuchoo . . . . .             | . . . . .                    | . . . . .                   | Truffles.                              |
| 156 | Kibbur . . . . .                  | . . . . .                    | Caubul . . . . .            | Capparis spinosa?                      |

| No. | —                       | Synonyms.             | Places whence Obtained. | Scientific Names, &c.           |
|-----|-------------------------|-----------------------|-------------------------|---------------------------------|
| 157 | Kibbur (bark of root).  |                       |                         |                                 |
| 158 | Kutol . . . . .         | . . . . .             | Dehli.                  |                                 |
| 159 | Bekh Kurfs . . . . .    | . . . . .             | Caul . . . . .          | <i>Apium graveolens.</i>        |
| 160 | Kurroo . . . . .        | . . . . .             | Hills . . . . .         | <i>Gentiana.</i>                |
| 161 | Kissar Kejur . . . . .  | . . . . .             | Saharunpoor . . . . .   | <i>An Cissus.</i>               |
| 162 | Kuseroo . . . . .       | . . . . .             | Dehli . . . . .         | <i>Cyperus tuberosus.</i>       |
| 163 | Kukora . . . . .        | . . . . .             | India . . . . .         | <i>Momordica muricata.</i>      |
| 164 | Banj Kukora.            |                       |                         |                                 |
| 165 | Koondush . . . . .      | . . . . .             | . . . . .               | Apparently, <i>Costus.</i>      |
| 166 | Koothee.                |                       |                         |                                 |
| 167 | Kurkee pona kejur.      |                       |                         |                                 |
| 168 | Keer.                   |                       |                         |                                 |
| 169 | Guj peepul . . . . .    | . . . . .             | Himalayas . . . . .     | <i>Pothos scandens.</i>         |
| 170 | Gushoona.               |                       |                         |                                 |
| 171 | Giloh . . . . .         | . . . . .             | India . . . . .         | <i>Memisperumm condifolium.</i> |
| 172 | Gunmaturee.             |                       |                         |                                 |
| 173 | Gorkhe pan.             |                       |                         |                                 |
| 174 | Loofa . . . . .         | . . . . .             | Surat . . . . .         | <i>Atropa Mandrogam.</i>        |
| 175 | Mazrioon . . . . .      | . . . . .             | . . . . .               | <i>Daphne mezereon.</i>         |
| 176 |                         |                       |                         |                                 |
| 177 | Mahmiran . . . . .      | . . . . .             | Cashmere . . . . .      | <i>Ranunculus ficaria?</i>      |
| 178 | Mahmiran Khutai.        |                       |                         |                                 |
| 179 | Mahmiran (different).   |                       |                         |                                 |
| 180 |                         |                       |                         |                                 |
| 181 | Moghas . . . . .        | Muedi lukri . . . . . |                         | <i>Tetranthera.</i>             |
| 182 | Muleem . . . . .        | . . . . .             | Himalayas.              |                                 |
| 183 | Moosli suffed . . . . . | . . . . .             | Gwalior.                |                                 |
| 184 | Mooslee (another kind). |                       |                         |                                 |
| 185 | Moosli suffed . . . . . | Sawbul . . . . .      | India . . . . .         | <i>Bembax heptaphyllum.</i>     |
| 186 | Moosli siah.            |                       |                         |                                 |
| 187 | Moosli siah Dukhnee.    |                       |                         |                                 |
| 188 | Moosli siah, St.        |                       |                         |                                 |
| 189 | Bekh mhuk.              |                       |                         |                                 |
| 190 | Neergundi . . . . .     | . . . . .             | Dehli.                  |                                 |
| 191 | Nisoth, F.              |                       |                         |                                 |
| 192 | Nur Kuchoor.            |                       |                         |                                 |
| 193 | Wuj . . . . .           | Buch . . . . .        | Khorassan . . . . .     | <i>Acorus Calamus.</i>          |

## WOODS.

|     |                          |                                    |                  |                                |
|-----|--------------------------|------------------------------------|------------------|--------------------------------|
| 194 | Bardust abnoos . . . . . |                                    | India . . . . .  | Ebony.                         |
| 195 | Beejesar . . . . .       | Bijuk . . . . .                    | Dukhun.          |                                |
| 196 | Bookum . . . . .         | Puttung(sappan wood).              |                  | <i>Cæsalpinia sappan.</i>      |
| 197 | Pudmak . . . . .         | . . . . .                          | Deyrah . . . . . | <i>Prunus Puddum.</i>          |
| 198 | Tejbul . . . . .         | . . . . .                          | Hills . . . . .  | <i>Xanthoxylon aromaticum.</i> |
| 199 | Deodar . . . . .         | . . . . .                          | . . . . .        | <i>Pinus deodara.</i>          |
| 200 | Sundul abiuz . . . . .   | Sundul suffed (white sandal wood). | Dukhun . . . . . | <i>Santalum album.</i>         |
| 201 | Sundul ahmur . . . . .   | Rukut chundoun (red sandal wood).  | Poorub . . . . . | <i>Pterocarpus santalinus.</i> |
| 202 | Ood . . . . .            | Ood hindee . . . . .               | Hatras . . . . . | <i>Aloeseylon Agallochum.</i>  |
| 203 | Ood . . . . .            | Agur (aloes wood, eagle wood).     | . . . . .        | <i>Aquilaria Agallocha.</i>    |

## BARKS.

|     |                           |                     |                             |                                |
|-----|---------------------------|---------------------|-----------------------------|--------------------------------|
| 204 | Ukl Beer . . . . .        | Ikl beer . . . . .  | Poorub . . . . .            | <i>Datisca cannabina.</i>      |
| 205 | Burkuk Shirazee . . . . . | . . . . .           | Surat.                      |                                |
| 206 | Bharungee . . . . .       | . . . . .           | Almora . . . . .            | <i>Betula Bhojputra.</i>       |
| 207 | Bhoj puttra.              |                     |                             |                                |
| 208 | Bhumbel . . . . .         | . . . . .           | Himalayas . . . . .         | <i>Euonymus tingens.</i>       |
| 209 | Tejbul . . . . .          | . . . . .           | Himalayas . . . . .         | <i>Xanthoxylon aromaticum.</i> |
| 210 | Dar Cheenee . . . . .     | Cinnamon . . . . .  | Poorub . . . . .            | <i>Laurus cinnamomum.</i>      |
| 211 | Dar Sheeshan . . . . .    | Kuephul . . . . .   | Himalayas . . . . .         | <i>Myrica sapida.</i>          |
| 212 | Roo, St.                  |                     |                             |                                |
| 213 | Sut peora . . . . .       | Boorans . . . . .   | Foot of Himalayas . . . . . | <i>Rhododendron arboreum.</i>  |
| 214 | Tuj . . . . .             | Saleekhee . . . . . | Nujjibabad . . . . .        | <i>Laurus cassia?</i>          |
| 215 | Sunna.                    |                     |                             |                                |
| 216 | Ooshk chal.               |                     |                             |                                |
| 217 | Kirfae . . . . .          | . . . . .           | Furruckabad.                |                                |
| 218 | Koorchee.                 |                     |                             |                                |
| 219 | Koora . . . . .           | . . . . .           | Kheree Pass . . . . .       | <i>Echites.</i>                |
| 220 | Kunhar kapost.            |                     |                             |                                |
| 221 | Kayree, St.               |                     |                             |                                |
| 222 | Kheree chips, St.         |                     |                             |                                |
| 223 | Lulka.                    |                     |                             |                                |
| 224 | Lodh . . . . .            | . . . . .           | Himalayas . . . . .         | <i>Symplocos racemosa.</i>     |
| 225 | Musag, bark of Akhroot.   | Walnut.             |                             |                                |
| 226 | Mueda lakree . . . . .    | Chandrem . . . . .  | Almora . . . . .            | <i>Tetranthera apetala.</i>    |

## PLANTS.

| No. | —                         | Synonyms.                     | Places whence Obtained.          | Scientific Names, &c.                         |
|-----|---------------------------|-------------------------------|----------------------------------|-----------------------------------------------|
| 227 | Abroon . . . . .          | . . . . .                     | Dehli . . . . .                  | Labiatae.                                     |
| 228 | Arzuk.                    | . . . . .                     | . . . . .                        | . . . . .                                     |
| 229 | Oostookhoodoos . . . . .  | . . . . .                     | Caubul . . . . .                 | Prunella.                                     |
| 230 | Aspruk, St. . . . .       | . . . . .                     | . . . . .                        | Delphinium.                                   |
| 231 | Oostukhar . . . . .       | . . . . .                     | Dehli . . . . .                  | . . . . .                                     |
| 232 | Oosneh . . . . .          | Chulchuleera . . . . .        | Himalayas . . . . .              | Lichen islandicus.                            |
| 233 | Uftimoon . . . . .        | . . . . .                     | Caubul . . . . .                 | { Cuscuta Europæa.<br>C. reflexa substituted. |
| 234 | Uftimoon, F. . . . .      | . . . . .                     | Cashmere ?                       | . . . . .                                     |
| 235 | Uftimoon Kusmeeree.       | . . . . .                     | . . . . .                        | . . . . .                                     |
| 236 | Umr bel . . . . .         | . . . . .                     | Dehli . . . . .                  | Cuscuta.                                      |
| 237 | Ufsunteen Kusmeeree       | . . . . .                     | Caubul . . . . .                 | Artemisia absinthium ?                        |
| 238 | Ufsunteen, F.             | . . . . .                     | . . . . .                        | . . . . .                                     |
| 239 | Ufsunteen, spurious, St.  | . . . . .                     | . . . . .                        | . . . . .                                     |
| 240 | Ufsunteen . . . . .       | . . . . .                     | Peshawur.                        | . . . . .                                     |
| 241 | Ufsunteen, true, St.      | . . . . .                     | . . . . .                        | . . . . .                                     |
| 242 | Afeenoos . . . . .        | . . . . .                     | Dehli Surat.                     | . . . . .                                     |
| 243 | Akas bel.                 | . . . . .                     | . . . . .                        | . . . . .                                     |
| 244 | Aloosureesoon . . . . .   | . . . . .                     | Surat <i>viâ</i> Dehli.          | . . . . .                                     |
| 245 | Amareetum.                | . . . . .                     | . . . . .                        | . . . . .                                     |
| 246 | Umsookh . . . . .         | . . . . .                     | Surat.                           | . . . . .                                     |
| 247 | Umar Bent . . . . .       | Acid twigs . . . . .          | Dehli.                           | . . . . .                                     |
| 248 | Anarooli.                 | . . . . .                     | . . . . .                        | . . . . .                                     |
| 249 | Dukhun nirbisee . . . . . | Unteleh souda . . . . .       | Umritseer.                       | . . . . .                                     |
| 250 | Undhaolee . . . . .       | . . . . .                     | Dehli.                           | . . . . .                                     |
| 251 | Undaolee.                 | . . . . .                     | . . . . .                        | . . . . .                                     |
| 252 | Oonga . . . . .           | Chirchita . . . . .           | India . . . . .                  | Achyranthes aspera.                           |
| 253 | Oordabeg . . . . .        | . . . . .                     | Saharunpore.                     | . . . . .                                     |
| 254 | Babooneh . . . . .        | Chamomile . . . . .           | India . . . . .                  | Anthemis nobilis.                             |
| 255 | Baboneh, St.              | Chamomile ?                   | . . . . .                        | . . . . .                                     |
| 256 | Eema wanoo talee.         | . . . . .                     | . . . . .                        | . . . . .                                     |
| 257 | Badawurd . . . . .        | . . . . .                     | Surat . . . . .                  | An Hedysarum Alhagi.                          |
| 258 | Badrunj boyeh . . . . .   | Billee lotun . . . . .        | Poorub . . . . .                 | Ocymum.                                       |
| 259 | Balungoo . . . . .        | . . . . .                     | India, Kunawur                   | Dracocephalum Royleanum.                      |
| 260 | Birm Dundee . . . . .     | . . . . .                     | India.                           | . . . . .                                     |
| 261 | Barunjasif . . . . .      | . . . . .                     | Nujjibabad . . . . .             | Artemisia.                                    |
| 262 | Buryaleh . . . . .        | Buj bund Khuerentee           | India . . . . .                  | Sida cordifolia.                              |
| 263 | Buree boontee.            | . . . . .                     | . . . . .                        | . . . . .                                     |
| 264 | Bomadrum.                 | . . . . .                     | . . . . .                        | . . . . .                                     |
| 265 | Bulsan . . . . .          | Balm of Gilead tree . . . . . | Surat . . . . .                  | Balsam odendron.                              |
| 266 | Bunufsuj . . . . .        | . . . . .                     | Cashmere and Himalayas.          | Viola repens.                                 |
| 267 | Bunufsha.                 | . . . . .                     | . . . . .                        | . . . . .                                     |
| 268 | Birr peroza.              | . . . . .                     | . . . . .                        | . . . . .                                     |
| 269 | Beh, St. . . . .          | . . . . .                     | . . . . .                        | Nelumbii, Rhizoma.                            |
| 270 | Bhuenphullee . . . . .    | . . . . .                     | Dehli.                           | . . . . .                                     |
| 271 | Bhuen pullee.             | . . . . .                     | . . . . .                        | . . . . .                                     |
| 272 | Bhuenphullee, 2nd         | . . . . .                     | . . . . .                        | . . . . .                                     |
| 273 | Bhung . . . . .           | . . . . .                     | Dehli . . . . .                  | Cannabis sativa.                              |
| 274 | Bhunug.                   | . . . . .                     | . . . . .                        | . . . . .                                     |
| 275 | Patree.                   | . . . . .                     | . . . . .                        | . . . . .                                     |
| 276 | Parpat, F.                | . . . . .                     | . . . . .                        | . . . . .                                     |
| 277 | Paluk ?? F. . . . .       | . . . . .                     | . . . . .                        | Spinacia oleracea.                            |
| 278 | Putol Puthur . . . . .    | . . . . .                     | Dehli.                           | . . . . .                                     |
| 279 | Pureeseaoshan . . . . .   | Mobarkha hunsraj . . . . .    | Himalayas . . . . .              | Adiantum.                                     |
| 280 | Moobarka, F.              | . . . . .                     | . . . . .                        | . . . . .                                     |
| 281 | Moobarka.                 | . . . . .                     | . . . . .                        | . . . . .                                     |
| 282 | Purseea Oshan, St.        | . . . . .                     | . . . . .                        | . . . . .                                     |
| 283 | Purol luttee, branches.   | . . . . .                     | . . . . .                        | . . . . .                                     |
| 284 | Podenca, F.               | . . . . .                     | . . . . .                        | . . . . .                                     |
| 285 | Tootiyae Haroonee, St.    | . . . . .                     | . . . . .                        | . . . . .                                     |
| 286 | Julneem . . . . .         | . . . . .                     | Dehli . . . . .                  | Herpestes Monniera.                           |
| 287 | Julneem, 2nd . . . . .    | . . . . .                     | Dehli.                           | . . . . .                                     |
| 288 | Juwansa . . . . .         | . . . . .                     | India . . . . .                  | Hedysarum Alhagi.                             |
| 289 | Jownchee . . . . .        | . . . . .                     | Dehli.                           | . . . . .                                     |
| 290 | Jownchee, 2nd . . . . .   | . . . . .                     | Dehli.                           | . . . . .                                     |
| 291 | Chob . . . . .            | Guj peepul . . . . .          | Nujjibabad . . . . .             | Appears to be stem of Pothos.                 |
| 292 | Hasha . . . . .           | . . . . .                     | Surat <i>viâ</i> Dehli . . . . . | Given for thyme.                              |
| 293 | Hishweh, St.              | . . . . .                     | . . . . .                        | . . . . .                                     |
| 294 | Hulimoo . . . . .         | . . . . .                     | Surat <i>viâ</i> Dehli.          | . . . . .                                     |
| 295 | Humama . . . . .          | . . . . .                     | Surat . . . . .                  | Given for amomum of ancients.                 |
| 296 | Humama . . . . .          | . . . . .                     | Caubul.                          | . . . . .                                     |
| 297 | Humama . . . . .          | . . . . .                     | Dehli.                           | . . . . .                                     |
| 298 | Khutsoo, St.              | . . . . .                     | . . . . .                        | . . . . .                                     |
| 299 | Khusfer, St.              | . . . . .                     | . . . . .                        | . . . . .                                     |
| 300 | Khurzeen, St.             | . . . . .                     | . . . . .                        | . . . . .                                     |
| 301 | Dickamallee, F. . . . .   | . . . . .                     | . . . . .                        | Gardenia lucida.                              |
| 302 | Durmineh, F.              | . . . . .                     | . . . . .                        | . . . . .                                     |
| 303 | Doodhee, 2nd . . . . .    | . . . . .                     | Dehli . . . . .                  | Euphorbia.                                    |
| 304 | Dhool phoollee.           | . . . . .                     | . . . . .                        | . . . . .                                     |

| No. | —                           | Synonyms.                   | Places whence Obtained. | Scientific Names, &c.                |
|-----|-----------------------------|-----------------------------|-------------------------|--------------------------------------|
| 305 | Usna Kusmeeree.             |                             |                         |                                      |
| 306 | Rutunjot.                   |                             |                         |                                      |
| 307 | Rutunjot, 2nd.              |                             |                         |                                      |
| 308 | Zak.                        |                             |                         |                                      |
| 309 | Zurnub . . . . .            | Bishmee . . . . .           | Himalayas . . . . .     | Taxus baccatus.                      |
| 310 | Zuek.                       |                             |                         |                                      |
| 311 | Zoofae, F. . . . .          |                             |                         | Hyssopus.                            |
| 312 | Zoofae yabus . . . . .      |                             |                         | Hyssopus officinalis.                |
| 313 | Sal purnee . . . . .        |                             | Deyra Doon . . . . .    | Shorea robusta.                      |
| 314 | Sitawal, St., branches.     |                             |                         |                                      |
| 315 | Sudab, 2nd . . . . .        | Soorut, F. . . . .          | Himalayas . . . . .     | Ruta parviflora?<br>— graveolens? F. |
| 316 | Sudee . . . . .             |                             | India.                  |                                      |
| 317 | Surphonka . . . . .         |                             | India . . . . .         | Galega.                              |
| 318 | Sureeoeoe.                  |                             |                         |                                      |
| 319 | Sunpat, St.                 |                             |                         |                                      |
| 320 | Singha Koolee . . . . .     |                             | India.                  |                                      |
| 321 | Shah tureh . . . . .        | Pit papra . . . . .         | India . . . . .         | Fumaria parviflora.                  |
| 322 | Shookae . . . . .           | Substitute given . . . . .  | Surat . . . . .         | Cratogeus oxyacantha.                |
| 323 | Toorfa . . . . .            |                             | Jumna . . . . .         | Tamarix.                             |
| 324 | Oosbeh mughrubee . . . . .  |                             | Arabia . . . . .        | Sarsaparilla, kind of.               |
| 325 | Garikoon.                   |                             |                         |                                      |
| 326 | Garikoon, F. . . . .        |                             | Peshawur . . . . .      | Agaricum.                            |
| 327 | Ghafis.                     |                             |                         |                                      |
| 328 | Furasion piabee . . . . .   |                             |                         | Agrimoniae sp.                       |
| 329 | Foodnuj burree.             |                             |                         |                                      |
| 330 | Poonjee, F., stems of Koot  |                             |                         |                                      |
| 331 | Kusb ool Zureareh . . . . . | Cheritta . . . . .          | Dakhun . . . . .        | Swertia chiretta.                    |
| 332 | Kintooroon . . . . .        |                             | India, Caubul . . . . . | Polycarpaea corymbosa.               |
| 333 | Kakjhunk.                   |                             |                         |                                      |
| 334 | Kal meel.                   |                             |                         |                                      |
| 335 | Kishun Gonar.               |                             |                         |                                      |
| 336 | Kulesur . . . . .           |                             | Dehli . . . . .         | Aristolochia.                        |
| 337 | Koondush . . . . .          | Nukh chinknee . . . . .     |                         | Artemisia sternutatoria.             |
| 338 | Kintoree.                   |                             |                         |                                      |
| 339 | Koorund, not true, F.       |                             |                         |                                      |
| 340 | Khuttoo . . . . .           |                             | Dehli.                  |                                      |
| 341 | Gahro, St. . . . .          | Stem Guj Peepul.            |                         |                                      |
| 342 | Gurgur muneek.              |                             |                         |                                      |
| 343 | Gurgur muneek, 2nd.         |                             |                         |                                      |
| 344 | Gugundhol . . . . .         |                             | Doab.                   |                                      |
| 345 | Gul miryun, St.             |                             |                         |                                      |
| 346 | Guggoo Ghiroo.              |                             |                         |                                      |
| 347 | Geelur putta . . . . .      |                             |                         | Laminariae sp.                       |
| 348 | Laltak, St.                 |                             |                         |                                      |
| 349 | Lutopuree.                  |                             |                         |                                      |
| 350 | Gao Zuban, St. . . . .      | Ox-tongue . . . . .         |                         | Boraginæe.                           |
| 351 | Gao Zuban Kohee.            |                             |                         |                                      |
| 352 | Gao Zuban, St.              |                             |                         | A. trichodesma.                      |
| 353 | Lukmuna Lukmame . . . . .   |                             | Dehli.                  |                                      |
| 354 | Mukareh . . . . .           |                             | Patna . . . . .         | Euryale.Ferox.                       |
| 355 | Mooshk tureh.               |                             |                         |                                      |
| 356 | Mueda deegar                |                             |                         |                                      |
| 357 | Nuk Chinknee.               |                             |                         |                                      |
| 358 | Nah.                        |                             |                         |                                      |
| 359 | Nirgund Baburee . . . . .   |                             | Dehli.                  |                                      |
| 360 | Khundish, St.               |                             |                         |                                      |
| 361 | Nuk Chinknee.               |                             |                         |                                      |
| 362 | Neel Kunthee . . . . .      |                             | Dehli . . . . .         | Ajuga.                               |
| 363 | Hatha jooree . . . . .      | Ceylon moss . . . . .       | Lucknow . . . . .       | Polypodii spec.?                     |
| 364 |                             | Leaves . . . . .            |                         | Gracillaria lichenoides.             |
| 365 | Arnee ke pat . . . . .      |                             | Bengal.                 |                                      |
| 366 | Bansa . . . . .             |                             | India . . . . .         | Justicia adhatoda.                   |
| 367 | Burkuk Shirazee.            |                             |                         |                                      |
| 368 | Burg Tibbut . . . . .       | Hoolas Cashmeeree . . . . . | Cashmere . . . . .      | Rhododendron campanulatum.           |
| 369 | Pucha Pat . . . . .         | Patchouli . . . . .         | Penang.                 |                                      |
| 370 | Pulwul, F. . . . .          |                             |                         | Cucurbitacæe.                        |
| 371 | Poosht burnee . . . . .     | Chit Kubra . . . . .        | India . . . . .         | Hedysarum alopecuroides.             |
| 372 | Hinna . . . . .             | Mehendee . . . . .          | India . . . . .         | Lawsonia inermis.                    |
| 373 | Ra Senna . . . . .          |                             |                         | Salvadora (jal) lanceolata.          |
| 374 | Saduj Hindee . . . . .      | Tez pat . . . . .           | Himalayas . . . . .     | Laurus cassia.                       |
| 375 | Suna . . . . .              |                             |                         | Cassia lanceolata.                   |
| 376 | Senna.                      |                             |                         |                                      |
| 377 | Senna, F. . . . .           |                             | Peshawur.               |                                      |
| 378 | Satur.                      |                             |                         |                                      |
| 379 | Burg Satur . . . . .        |                             | Arabia . . . . .        | Origanum vulgare.                    |
| 380 | Kamohee, St. jo pun         |                             |                         | Phyllanthus multiflorus.             |
| 381 | Kubrah.                     |                             |                         |                                      |
| 382 | Kusoundhee . . . . .        |                             |                         | Cassia sophora.                      |
| 383 | Gugerun . . . . .           |                             |                         | Grewia hirsuta.                      |



## FLOWERS.

| No. | —                       | Synonyms.                        | Places whence Obtained. | Scientific Names, &c. |
|-----|-------------------------|----------------------------------|-------------------------|-----------------------|
| 384 | Ukleel ool jibbul . . . | . . .                            | Delhi Surat . . .       | Acacia Arabica.       |
| 385 | Babool.                 | . . .                            | . . .                   | . . .                 |
| 386 | Babooneh . . .          | . . .                            | Smyrna . . .            | Chamomile flowers.    |
| 387 | Bukoombur . . .         | . . .                            | India . . .             | Careya arborea.       |
| 388 | Bunufsj . . .           | . . .                            | Cashmere . . .          | Viola.                |
| 389 | Bol ke phool.           | . . .                            | . . .                   | . . .                 |
| 390 | Booree, St. . . . .     | Made from pollen of<br>bullrush. | . . .                   | . . .                 |
| 391 | Tesoo, F. . . . .       | . . .                            | . . .                   | Butea frondosa.       |
| 392 | Julnar . . . . .        | Goolanar . . . . .               | India . . . . .         | Punica granatum.      |
| 393 | Gool Khueroo, F.        | . . .                            | . . .                   | . . .                 |
| 394 | Dha . . . . .           | . . .                            | . . .                   | Grislea tomentosa.    |
| 395 | Zafaran . . . . .       | . . .                            | Saffron . . . . .       | Crocus sativus.       |
| 396 | Seotee.                 | . . .                            | . . .                   | . . .                 |
| 397 | Gooli Ghafis, F.        | . . .                            | . . .                   | . . .                 |
| 398 | Gooli Ghafis.           | . . .                            | . . .                   | . . .                 |
| 399 | . . . . .               | . . .                            | Safflower.              | . . .                 |
| 400 | Gool soorukh, F.        | . . .                            | . . .                   | . . .                 |
| 401 | Goontnee.               | . . .                            | . . .                   | . . .                 |
| 402 | Gao Zuban.              | . . .                            | . . .                   | . . .                 |
| 403 | Moondhee . . . . .      | . . .                            | . . .                   | Sphæranthus indicus.  |
| 404 | Nagkesur . . . . .      | Nar mooshk . . . . .             | . . .                   | Mesua ferrea.         |
| 405 | Neelofer . . . . .      | . . .                            | . . .                   | Nymphœa alba.         |

## FRUITS AND SEEDS.

|     |                            |                                 |                                 |                                |
|-----|----------------------------|---------------------------------|---------------------------------|--------------------------------|
| 406 | Aarghees.                  | Zirishk . . . . .               | Hills . . . . .                 | Berberis Chitra.               |
| 407 | Ubhool . . . . .           | Hoober, Huber . . . . .         | St. Umritseer . . . . .         | Juniper berries.               |
| 408 | Ubhool.                    | . . .                           | . . .                           | . . .                          |
| 409 | Ooturuj . . . . .          | Bijuoree neemboo . . . . .      | Gardens . . . . .               | Citron.                        |
| 410 | Usl . . . . .              | Furas . . . . .                 | India . . . . .                 | Tamarix dioica.                |
| 411 | Usluk . . . . .            | . . .                           | India . . . . .                 | Vitea trifolia.                |
| 412 | Oojas . . . . .            | Aloo Bokhara . . . . .          | Caul and Cashmere . . . . .     | Prunus Bokhariensis.           |
| 413 | . . . . .                  | Alu Chumra, St. . . . .         | Khorassan . . . . .             | Acid plum.                     |
| 414 | Ujmood . . . . .           | Arub ujwain . . . . .           | India . . . . .                 | Ptychotis ajowan.              |
| 415 | Ajwain . . . . .           | . . .                           | From Dr. Christison.            | . . .                          |
| 416 | . . . . .                  | Nan Khooah.                     | . . .                           | . . .                          |
| 417 | Ajowan or Wull Tan, St.    | . . .                           | . . .                           | . . .                          |
| 418 | Ehreez . . . . .           | Kusoomba ke kuen . . . . .      | India . . . . .                 | Carthamus tinctorius.          |
| 419 | Ukhburoos . . . . .        | Kul-gehoon . . . . .            | Hills and Khadir,<br>Chilkhana. | Coix indica.                   |
| 420 | Aruz . . . . .             | Birunj . . . . .                | Doab Canal . . . . .            | Oryza sativa.                  |
| 421 | . . . . .                  | Var. Bansmutti . . . . .        | Doab Canal.                     | . . .                          |
| 422 | . . . . .                  | Birinj Peshawvee, St.           | . . .                           | . . .                          |
| 423 | . . . . .                  | Himalayan rice.                 | . . .                           | . . .                          |
| 424 | . . . . .                  | Bunsmutti.                      | . . .                           | . . .                          |
| 425 | Aruz, Birunj Pers.         | Chanwul, Dhan . . . . .         | . . . . .                       | Rice.                          |
| 426 | Azarakee . . . . .         | Koochla . . . . .               | India, Poorub . . . . .         | Strychnas nux vomica.          |
| 427 | Urjan . . . . .            | . . .                           | . . .                           | Hill apricot.                  |
| 428 | As. and St. . . . .        | . . .                           | Cashmere . . . . .              | Myrtus communis.               |
| 429 | Asartursh . . . . .        | Dana . . . . .                  | Bussorah.                       | . . .                          |
| 430 | Ufrunjeh . . . . .         | . . .                           | Dehli and Caubul . . . . .      | Urtica.                        |
| 431 | Ukut mukut . . . . .       | Kutkurenja Kurenjwa . . . . .   | India . . . . .                 | Cæsalpinia bonducella.         |
| 432 | Ukleel ool mulik . . . . . | . . .                           | Caubul . . . . .                | Melilot.                       |
| 433 | . . . . .                  | Allspice . . . . .              | Calcutta Bazaar . . . . .       | Allspice.                      |
| 434 | Ummoghelan . . . . .       | Keckur . . . . .                | . . .                           | Acacia farnesiana.             |
| 435 | Umluj . . . . .            | Aonla, Emblica my-<br>robolans. | . . .                           | Phyllanthus emblica.           |
| 436 | Unbuj . . . . .            | Anab, umchoor . . . . .         | India . . . . .                 | Unripe fruit, dried.           |
| 437 | Amchou . . . . .           | . . .                           | Bengal . . . . .                | . . .                          |
| 438 | Unjidan . . . . .          | . . .                           | Surat via Dehli . . . . .       | Ferula assafœtida.             |
| 439 | . . . . .                  | Dookoo . . . . .                | Arabia.                         | . . .                          |
| 440 | Indjan . . . . .           | . . .                           | . . .                           | . . .                          |
| 441 | . . . . .                  | St. Hingotey jo pur . . . . .   | . . .                           | Assafœtida?                    |
| 442 | Unjidan, 2nd . . . . .     | . . .                           | Saharunpore Surat.              | . . .                          |
| 443 | Unjidan, F. . . . .        | . . .                           | Astoria in Tibet . . . . .      | Narthex assafœtida.            |
| 444 | Sir T. McNeill's . . . . . | . . .                           | Herat . . . . .                 | . . .                          |
| 445 | Oudung, St. . . . .        | . . .                           | . . .                           | An urtica?                     |
| 446 | Ootungun, F. . . . .       | . . .                           | . . .                           | . . .                          |
| 447 | Unjereh.                   | . . .                           | . . .                           | . . .                          |
| 448 | Aneesoan . . . . .         | Aniseed . . . . .               | Caubul . . . . .                | Applied to apium petroselinum. |
| 449 | . . . . .                  | . . .                           | Bengal . . . . .                | Aniseed.                       |
| 450 | Aneesoan, F. . . . .       | . . .                           | Umritseer.                      | . . .                          |
| 451 | Aneesoan, F. . . . .       | . . .                           | Caubul.                         | . . .                          |
| 452 | Aneson . . . . .           | . . .                           | . . .                           | Pimpinella involucrata.        |
| 453 | Anoola . . . . .           | . . .                           | India.                          | . . .                          |
| 454 | Ooafenoos . . . . .        | . . .                           | Surat.                          | . . .                          |

| No. | —                                  | Synonyms.                   | Places whence Obtained.     | Scientific Names, &c.             |
|-----|------------------------------------|-----------------------------|-----------------------------|-----------------------------------|
| 455 | Ootungun . . . . .                 |                             | Lucnow.                     |                                   |
| 456 | Ootungun.                          |                             |                             |                                   |
| 457 | Unteh mora . . . . .               |                             |                             | Helicteres.                       |
| 458 | Oonga . . . . .                    |                             | India . . . . .             | Achyranthes aspera.               |
| 459 | Ahlub . . . . .                    |                             | Surat.                      |                                   |
| 460 | Ahleluj bijwara . . . . .          | Hura zurd . . . . .         | India . . . . .             | Terminalia                        |
| 461 | Hurra takee . . . . .              |                             | Dr. Christison.             |                                   |
| 462 | Ahleluj Kaboolee . . . . .         |                             | Caubul.                     |                                   |
| 463 | Ahleluj Behera, F. . . . .         |                             |                             | Terminalia.                       |
| 464 | Ahleluj Behra ? . . . . .          |                             |                             |                                   |
| 465 | Ahleluj usfur . . . . .            |                             | India . . . . .             | Terminalia chebula.               |
| 466 | Ahleluj uswnd . . . . .            |                             |                             | Terminalia chebula.               |
| 467 | Ahleluj uswud, juwa, hure<br>juwa. |                             |                             |                                   |
| 468 | Oorud chulaka, F. . . . .          |                             |                             |                                   |
| 469 | Oorud seeah. . . . .               |                             |                             |                                   |
| 470 | Babchee and F. . . . .             |                             |                             | Psoralea corylifolia.             |
| 471 | Bawurchee, St. . . . .             |                             |                             |                                   |
| 472 | Badam Chenee . . . . .             |                             |                             | Arachis hypoga.                   |
| 473 | Badrooj . . . . .                  |                             | Furuckabad . . . . .        | Ocymum ?                          |
| 474 | Badinjan . . . . .                 |                             | India . . . . .             | Egg plant. Solanum melangena.     |
| 475 | Maroo Banjun, F. . . . .           |                             |                             |                                   |
| 476 | Badian Khutai . . . . .            |                             | China . . . . .             | Star anise, Illicium anisatum.    |
| 477 | Bartung. . . . .                   |                             |                             |                                   |
| 478 | Bakla . . . . .                    |                             |                             | Bean, Faba vulgaris.              |
| 479 | Bakla . . . . .                    |                             | Gardens . . . . .           | Bean, Faba vulgaris.              |
| 480 | Bakla, sem. . . . .                |                             |                             | Dolichos sp.                      |
| 481 | Bakla . . . . .                    | Shirazec. . . . .           |                             |                                   |
| 482 | Sem . . . . .                      |                             | Bengal. . . . .             |                                   |
| 483 | Bakla misree . . . . .             | Kuml ghutta . . . . .       |                             | Nelumbium speciosum.              |
| 484 | Badkoomb . . . . .                 |                             | Bengal . . . . .            | Careya ?                          |
| 485 | Balungoo . . . . .                 |                             | India . . . . .             | Dracocephalum Royleanum.          |
| 486 | Balbeej, St. . . . .               |                             |                             |                                   |
| 487 | Baebhungar . . . . .               |                             | India . . . . .             | Vitex.                            |
| 488 | Bucheh tirak . . . . .             |                             | Bengal. . . . .             |                                   |
| 489 | Birunj Kaboolee . . . . .          | Bae bhirung . . . . .       | Nujjibabad . . . . .        | Embelia ribes.                    |
| 490 | Beibarung. . . . .                 |                             |                             |                                   |
| 491 | Buryana . . . . .                  | Khurentee . . . . .         |                             | Seda.                             |
| 492 | Buzr Katoona . . . . .             |                             | India, Gardens . . . . .    | Plantago Isufghol.                |
| 493 | Buzr, F. . . . .                   | Ispugol . . . . .           | Dehli. . . . .              |                                   |
| 494 | Bisbaseh . . . . .                 |                             |                             | Mace, Myristica Moschata.         |
| 495 | Bistitaj . . . . .                 |                             | Delhi. . . . .              |                                   |
| 496 | Buteekh hindce . . . . .           | Turbooz . . . . .           |                             | Water Melon, Cucurbite citrullus. |
| 497 | Buloot . . . . .                   |                             |                             | Quercus.                          |
| 498 | Buloot . . . . .                   | Shah Buloot, St. . . . .    |                             | Quercus.                          |
| 499 | Buloot . . . . .                   |                             | Surat, Acorns . . . . .     | Quercus.                          |
| 500 | Nimoorea Bukayee, St. . . . .      |                             |                             | Melia Bukayun.                    |
| 501 | Biladur . . . . .                  | Bhilanwa . . . . .          |                             | Semecarpus Anacardium.            |
| 502 | Hub Balsan, St. . . . .            |                             |                             | Balsamodendron.                   |
| 503 | Hub ool Balsan . . . . .           |                             |                             | Balsamodendron Gileadense.        |
| 504 | Boon, F. . . . .                   | Kuhwah . . . . .            |                             | Coffee, Coffea Arabica.           |
| 505 | Buleluj . . . . .                  | Behera . . . . .            | India . . . . .             | Terminalia Bellerica.             |
| 506 | Bunj . . . . .                     | Ujwin Khorassanee . . . . . | Dehli . . . . .             | Hyoscyamus niger.                 |
| 507 | Benda Toree, F. . . . .            |                             | Gardens, India . . . . .    | Hibiscus.                         |
| 508 | Bindal . . . . .                   |                             | India . . . . .             | Momordica.                        |
| 509 | Binduk . . . . .                   | Finduk . . . . .            | Hills, Hazel Nut . . . . .  | Corylus lacera.                   |
| 510 | Binduk hindce . . . . .            | Reetha . . . . .            | India, Soap Nut . . . . .   | Sapindus detergens.               |
| 511 | Bomaderan . . . . .                |                             | Surat, Dehli. . . . .       |                                   |
| 512 | Boomadur, St. . . . .              | Gen madur, St. . . . .      |                             | An Absinthium.                    |
| 513 | Boee . . . . .                     |                             | Dehli. . . . .              |                                   |
| 514 | Beej Bund . . . . .                |                             | Dehli. . . . .              |                                   |
| 515 | Bel geeree . . . . .               |                             |                             | Ægle Marmelos.                    |
| 516 | Belgeeree, St. . . . .             | Pulghur, Katturo. . . . .   |                             |                                   |
| 517 | Bol. . . . .                       |                             |                             |                                   |
| 518 | Buengun junglee . . . . .          |                             | Dehli . . . . .             | Solanum.                          |
| 519 | Bhung Puharee, F. . . . .          | Hemp seed . . . . .         | Teree, Himalaya . . . . .   | Cannabis sativâ.                  |
| 520 | Bhenjaree . . . . .                |                             |                             | Zizyphus ?                        |
| 521 | Padul . . . . .                    |                             | India . . . . .             | Bignonia suaveolens.              |
| 522 | Loll Paluk, F. . . . .             |                             |                             | Spinage.                          |
| 523 | Paluk, F. . . . .                  |                             |                             |                                   |
| 524 | Phaphra, F. . . . .                |                             |                             | Buckwheat.                        |
| 525 | Papecta . . . . .                  |                             | St. Ignatius Bean . . . . . | Strychnos Ignatia.                |
| 526 | Purusphul . . . . .                |                             |                             | Lagerstromia ?                    |
| 527 | Pulas Papreh . . . . .             |                             |                             | Butea frondosa.                   |
| 528 | Punwar . . . . .                   | Chukonda . . . . .          |                             | Cassia Tora.                      |
| 529 | Petha . . . . .                    |                             | Indian Pumpkin . . . . .    | Cucurbita Pepo.                   |
| 530 | Petha, F. . . . .                  |                             |                             |                                   |
| 531 | Phulwa . . . . .                   |                             | Almora . . . . .            | Bassia butyracea.                 |
| 532 | Peloo . . . . .                    |                             | Hansi . . . . .             | Capparis aphylla.                 |
| 533 | Peeaz . . . . .                    |                             |                             | Onion, Allium cepa.               |
| 534 | Peepul . . . . .                   | Dar Filfil . . . . .        | Bengal . . . . .            | Piper longum.                     |
| 535 | Punir jo fotah, St. . . . .        |                             |                             |                                   |
| 536 | Tal mookhana . . . . .             |                             | India . . . . .             | Barleria longifolia.              |
| 537 | Tal mukhana. . . . .               |                             |                             |                                   |

| No. | —                              | Synonyms.                | Places whence Obtained.          | Scientific Names, &c.                     |
|-----|--------------------------------|--------------------------|----------------------------------|-------------------------------------------|
| 538 | Siah Tal mokhana.              |                          |                                  |                                           |
| 539 | Turbooz, F.                    |                          |                                  |                                           |
| 540 | Tuk marya.                     |                          |                                  |                                           |
| 541 | Turyak, St. . . . .            |                          |                                  | Inside husk of Areca.                     |
| 542 | Peearanga . . . . .            |                          | Bengal.                          |                                           |
| 543 | Tushmeezuj . . . . .           | Chaksoo . . . . .        | Deyra Dhoon . . . . .            | Cassia acacalis.                          |
| 544 | Toorunj . . . . .              |                          |                                  | Citron rind.                              |
| 545 | Toorunj . . . . .              |                          |                                  |                                           |
| 546 | Toormus. . . . .               |                          |                                  | White lupin, <i>Lupinus albus</i> .       |
| 547 | Tumr . . . . .                 | Choochara . . . . .      |                                  | Date, <i>Phoenix dactylifera</i>          |
| 548 | Tumr hindce . . . . .          |                          |                                  | Tamarind, <i>Tamarindus indica</i> .      |
| 549 | Tunterech . . . . .            | Marwar . . . . .         | India . . . . .                  | <i>Rhus parviflorum</i> .                 |
| 550 | Toree seeah . . . . .          | Kalee toree. . . . .     |                                  |                                           |
| 551 | Toree ghia . . . . .           |                          | India . . . . .                  | <i>Luffa acutangula</i> .                 |
| 552 | Toree tulkh . . . . .          | Kurwee toree . . . . .   |                                  | <i>Luffa pentandra</i> .                  |
| 553 | Todree suffed . . . . .        |                          |                                  | <i>Cheiranthus cheiri</i> .               |
| 554 | Todree soorkh, F. . . . .      |                          |                                  | <i>Cheiranthus</i> .                      |
| 555 | Todri soorkh, St. . . . .      |                          |                                  | Malva.                                    |
| 556 | Todree Zurd . . . . .          |                          | Caubul, India . . . . .          | <i>Cheiranthus</i> .                      |
| 557 | Toreeah, F. . . . .            |                          |                                  | Sinapis.                                  |
| 558 | Tor, F. . . . .                |                          |                                  | <i>Cytisus Cajan</i> .                    |
| 559 | Toon, F. . . . .               |                          |                                  | <i>Cedrela Toona</i> .                    |
| 560 | Thy gul. . . . .               |                          |                                  |                                           |
| 561 | Teen . . . . .                 |                          | Caubul . . . . .                 | Fig, <i>Ficus Carica</i> .                |
| 562 | Tent . . . . .                 |                          |                                  | <i>Capparis aphylla</i> .                 |
| 563 | Jamphul . . . . .              |                          | Surat.                           |                                           |
| 564 | Jamun, F. . . . .              |                          |                                  | <i>Eugenia</i> .                          |
| 565 | Jawarus . . . . .              | Bajra . . . . .          | India . . . . .                  | <i>Panicum spicatum</i> .                 |
| 566 | Jurjur . . . . .               | Tirehtizak . . . . .     | India . . . . .                  | <i>Moricandia tira</i> .                  |
| 567 | Jazur . . . . .                | Gagur . . . . .          |                                  | Carrot, <i>Daucus Carota</i> .            |
| 568 | Jouz . . . . .                 | Ukhroot . . . . .        | Himalayas . . . . .              | Walnut, <i>Juglans regia</i> .            |
| 569 | Jouz ool suroo . . . . .       |                          | Hills . . . . .                  | <i>Cupressus sempervirens</i> .           |
| 570 | Jouz ool Kitah . . . . .       |                          | Arabia . . . . .                 | <i>Solanum</i> sp.                        |
| 571 | Jouz ool Kue . . . . .         | Muenphul . . . . .       |                                  | <i>Posoqueria dumetorum</i> .             |
| 572 | Jouz ool Kue, F. . . . .       | Muenphul . . . . .       |                                  | <i>Posoqueria</i> .                       |
| 573 | Jouz boa . . . . .             | Juephul . . . . .        | Spice Islands . . . . .          | Nutmeg, <i>Myristica moschata</i> .       |
| 574 | Jouz boa . . . . .             |                          |                                  | Wild nutmeg, <i>Myristica tomentosa</i> . |
| 575 | Jouz roomee . . . . .          |                          | Surat . . . . .                  | <i>Zizyphus</i> sp.                       |
| 576 | Jouz masil . . . . .           | Dhatoora . . . . .       | India . . . . .                  | <i>Datura metel</i> .                     |
| 577 | Dhatora suffed. . . . .        |                          |                                  |                                           |
| 578 | Jouz masil uswud . . . . .     | Kala dhatoora . . . . .  | India . . . . .                  | Substitute for <i>Datura fastuosa</i> .   |
| 579 | Jeeapota . . . . .             |                          | India . . . . .                  | <i>Nageia Putranjiva</i> .                |
| 580 | Chah . . . . .                 |                          | China . . . . .                  | <i>Thea viridis</i> .                     |
| 581 | Chimoti suffed, St. . . . .    |                          |                                  |                                           |
| 582 | Chaoolmoogra . . . . .         |                          |                                  | <i>Choulmoogra odorata</i> .              |
| 583 | Hasha, F. . . . .              |                          |                                  | Substitute for Thyme.                     |
| 484 | Hub ool Ban . . . . .          |                          | Surat <i>via</i> Dehli . . . . . | <i>Melia sempervirens</i> .               |
| 585 | Hub ool Ban. . . . .           |                          |                                  |                                           |
| 586 | Hub ool Khizra . . . . .       |                          |                                  | <i>Pistacia terebinthus</i> .             |
| 587 | Hub ool Zulm . . . . .         | Hub Zalam, St. . . . .   |                                  |                                           |
| 588 | Hub ool Sumneh . . . . .       |                          |                                  | <i>Buchanania latifolia</i> .             |
| 589 | Hub ool Ghar . . . . .         |                          |                                  | <i>Laurus nobilis</i> .                   |
| 590 | Hub ool Koolut . . . . .       |                          | Himalayas Cult. . . . .          | <i>Dolichoś</i> .                         |
| 591 | Hub ool Koolkool . . . . .     |                          |                                  | <i>Cardiospermum Halicacabum</i> .        |
| 592 | Hub ool mujjullub . . . . .    |                          | Almora . . . . .                 | <i>Rhus</i> .                             |
| 593 | Hub ool neel . . . . .         |                          |                                  | <i>Ipomea cærulea</i> .                   |
| 594 | Hirf . . . . .                 | Halim . . . . .          |                                  | <i>Lepidium sativum</i> .                 |
| 595 | Hoormul lahoree . . . . .      |                          |                                  | <i>Peganum harmala</i> .                  |
| 596 | Hoormal . . . . .              | Ispund, F. . . . .       |                                  | <i>Corchorus capsularis</i> .             |
| 597 | Hussuk . . . . .               | Gokroo Dukhune . . . . . |                                  | <i>Pedaliun murex</i> .                   |
| 598 | Hussuk, 2n 1 . . . . .         | Gokhroo . . . . .        |                                  | <i>Tribulus lanuginosus</i> .             |
| 599 | Hoolbeh . . . . .              | Methee . . . . .         |                                  | <i>Trigonella fœnugræcum</i> .            |
| 600 | Himaz . . . . .                | Pulkee . . . . .         |                                  | <i>Rumex undulatus</i> .                  |
| 601 | Gul Himaz, St. . . . .         |                          |                                  |                                           |
| 602 | Gul Himaz, St. . . . .         |                          |                                  |                                           |
| 603 | Humus abiuz . . . . .          | Chuna Kaboolee . . . . . |                                  | <i>Cicer arietinum</i> .                  |
| 604 | Humus ahmur . . . . .          | Lal Chuna . . . . .      |                                  | <i>Cicer arietinum</i> .                  |
| 605 | Kasnee . . . . .               |                          | India . . . . .                  | Chicory, <i>Cicorium intybus</i> .        |
| 606 | Kasnee siah . . . . .          |                          | Surat.                           |                                           |
| 607 | Hintch . . . . .               | Gehoon . . . . .         |                                  | <i>Triticum hybernum et Æstivum</i> .     |
| 608 | Kakshee, St. . . . .           |                          |                                  |                                           |
| 609 | Khoobanee, F. . . . .          |                          |                                  | Dried apricots.                           |
| 610 | Hunzil, F. . . . .             | Andorain . . . . .       |                                  | <i>Cucumis Colocynthis</i> .              |
| 611 | Khoob-bazee . . . . .          |                          |                                  | <i>Malva rotundifolia</i> .               |
| 612 | Khurbooza, F. . . . .          |                          |                                  | <i>Cucumis melo</i> .                     |
| 613 | Post Khurbooza . . . . .       |                          |                                  | Rind of melon.                            |
| 614 | Khoobeh, Khoob Kulan . . . . . |                          |                                  | <i>Sinapis pusilla</i> .                  |
| 615 | Khirfee . . . . .              |                          |                                  |                                           |
| 616 | Khurdul raee . . . . .         |                          |                                  | <i>Sinapis nigra</i> .                    |
| 617 | Khurnoob Shamee . . . . .      |                          | Carobs . . . . .                 | <i>Cerantonia Siliqua</i> .               |
| 618 | Khurnoob noobtee . . . . .     |                          |                                  | Cassia.                                   |
| 619 | Khiroa . . . . .               | Urundee . . . . .        |                                  | <i>Ricinus communis</i> .                 |
| 620 | Khiroa, F. . . . .             | Arundee, F. . . . .      | India.                           |                                           |
| 621 | Khus . . . . .                 | Kahor . . . . .          |                                  | <i>Lactuca sativa</i> .                   |

| No. | —                              | Synonyms.                     | Places whence Obtained.                    | Scientific Names, &c.                     |
|-----|--------------------------------|-------------------------------|--------------------------------------------|-------------------------------------------|
| 622 | Khush Khush abiuз . . .        | Post . . . . .                | . . . . .                                  | Papaver somniferum.                       |
| 623 | Khush Khush uswud . . .        | Huzara . . . . .              | . . . . .                                  |                                           |
| 624 | Khunjuk, St. . . . .           |                               |                                            |                                           |
| 625 | Khutmee . . . . .              |                               |                                            | Althæa rosea.                             |
| 626 | Khilaf . . . . .               | Bed mooshk . . . . .          |                                            | Salix Ægyptiaca.                          |
| 627 | Khundroos . . . . .            | Mukkee . . . . .              | Indian corn . . . . .                      | Zea Mays.                                 |
| 628 | Mukkee soorkh. . . . .         |                               |                                            |                                           |
| 629 |                                | Amultas . . . . .             |                                            | Cassia fistula.                           |
| 630 | Gool-i-dar cheenee, F. . . . . |                               | Peshawur . . . . .                         | Cinnamomum aromaticum.                    |
| 631 | Darim . . . . .                | Naspal . . . . .              | Himalayas . . . . .                        | Punica granatum.                          |
| 632 | Anak Danah, F. . . . .         |                               | Himalayas. . . . .                         |                                           |
| 633 | Darum . . . . .                |                               |                                            | Punica granatum.                          |
| 634 | Danuj abrooj . . . . .         |                               | Surat. . . . .                             |                                           |
| 635 | Dukhun . . . . .               |                               |                                            | Panicum miliaceum.                        |
| 636 | Dardab. . . . .                |                               |                                            |                                           |
| 637 | Dund . . . . .                 | Jumalgotta . . . . .          |                                            | Croton Tiglium.                           |
| 638 | Doodnee . . . . .              |                               |                                            | Euphorbia hirta.                          |
| 639 | Dhunuttur . . . . .            |                               |                                            | Clitoria ternatea.                        |
| 640 | Dak papra, F. . . . .          |                               |                                            | Batea frondosa.                           |
| 641 | Dek . . . . .                  |                               |                                            | Zizyphus.                                 |
| 642 | Doukoo . . . . .               | Unjidan . . . . .             |                                            | Ferula, sp. . . . .                       |
| 643 | Unjidan . . . . .              |                               | Cashmere. . . . .                          |                                           |
| 644 |                                |                               | Cashmere. . . . .                          |                                           |
| 645 | Dookoo, F. . . . .             |                               |                                            |                                           |
| 646 | Dookoo, F. . . . .             |                               | Delhi. . . . .                             |                                           |
| 647 | Dindana . . . . .              |                               |                                            | Composite.                                |
| 648 | Dundanah . . . . .             |                               | Umritseer, Peshawur. . . . .               |                                           |
| 649 | Zurt . . . . .                 |                               |                                            | Sorghum vulgare.                          |
| 650 | Ra sunna, F. . . . .           |                               | Fruit found along with the leaves. . . . . | Bertholletia ?                            |
| 651 | Ram putrec . . . . .           |                               |                                            | Myristica. . . . .                        |
| 652 | Ramputtree, St. . . . .        |                               | False mace. Picked. . . . .                | Often in a whole basket only broken mace. |
| 653 | Ranee . . . . .                |                               | Bengal . . . . .                           | Umbelliferae.                             |
| 654 | Roodrachel . . . . .           |                               |                                            | Eleocarpus Ganitrus.                      |
| 655 | Ruwaseen . . . . .             | Jeret . . . . .               |                                            | Æschynomene Sesban.                       |
| 656 | Reez . . . . .                 |                               |                                            |                                           |
| 657 | Zubeeb . . . . .               |                               |                                            | Raisins.                                  |
| 658 | Zubeeb ool jibbul . . . . .    | Given for stavesacre. . . . . |                                            | Delphinium Staphisagria.                  |
| 659 | Zuhr mor . . . . .             |                               |                                            | Leguminosæ.                               |
| 660 | Zuhr, another kind. . . . .    |                               |                                            |                                           |
| 661 | Zuetoon . . . . .              |                               |                                            | Olea zytoon.                              |
| 662 | Saj . . . . .                  |                               | India. Teak . . . . .                      | Tectona grandis.                          |
| 663 | Sal . . . . .                  |                               |                                            | Shorea robusta.                           |
| 664 | Saumach, F. . . . .            | Sauwak . . . . .              |                                            | Panicum.                                  |
| 665 | Sagoo Daneh . . . . .          |                               | Calcutta. . . . .                          |                                           |
| 666 | Sang . . . . .                 |                               | Hansi. . . . .                             |                                           |
| 667 | Sapistan . . . . .             |                               |                                            | Cordia Myxa.                              |
| 668 | Sudab . . . . .                |                               |                                            | Ruta graveolens.                          |
| 669 | Tookhm-i-sudab, F. . . . .     |                               | Caubul. . . . .                            |                                           |
| 670 | Tookhm-i-sudab, F. . . . .     |                               | Kabool. . . . .                            |                                           |
| 671 | Surshuf . . . . .              |                               |                                            | Sinapis dichotoma.                        |
| 672 | Surson . . . . .               |                               | Bengal. . . . .                            |                                           |
| 673 | Surwari . . . . .              |                               |                                            | Celosia argentea.                         |
| 674 | Sufur jul . . . . .            | Beh dana . . . . .            |                                            | Pyrus cydonia.                            |
| 675 | Bih Dana. . . . .              |                               |                                            |                                           |
| 676 | Saluk . . . . .                | Chookundur . . . . .          |                                            | Bete vulgaris.                            |
| 677 | Sumak . . . . .                | Kungnee . . . . .             |                                            | Panicum italicum.                         |
| 678 | Sumak . . . . .                | Toong . . . . .               | Hill's . . . . .                           | Rhus.                                     |
| 679 | Soomak, 2nd . . . . .          |                               |                                            | Rhus coriaria.                            |
| 680 | Semsin Safaed . . . . .        | Til . . . . .                 |                                            | Sesamum orientale.                        |
| 681 | Semsin . . . . .               | Til . . . . .                 | Saharunpore. . . . .                       |                                           |
| 682 | Sumundur phul . . . . .        |                               |                                            | Barringtonia acutangula.                  |
| 683 | Sumundur phul . . . . .        |                               |                                            |                                           |
| 684 | Sumundur sokh . . . . .        |                               | Khadir. . . . .                            |                                           |
| 685 | Sun . . . . .                  |                               |                                            | Hibiscus cannabinus.                      |
| 686 | Sunee-ke-beej. . . . .         |                               |                                            |                                           |
| 687 | Suna. . . . .                  |                               |                                            |                                           |
| 688 | Sinjud . . . . .               |                               | Cashmere . . . . .                         | Eleagnus sinjid.                          |
| 689 | Soomrakh . . . . .             |                               |                                            | Composite.                                |
| 690 | Soolfa . . . . .               |                               |                                            | Umbelliferae.                             |
| 691 | Suns rooe . . . . .            |                               | Dehli . . . . .                            | Portulacæa.                               |
| 692 | Singhara . . . . .             |                               |                                            | Trapa hispinosa.                          |
| 693 | Sonf . . . . .                 | Razeeanuj . . . . .           |                                            | Pimpinella anisum.                        |
| 694 | Southee, F. . . . .            |                               | Saharunpore. . . . .                       |                                           |
| 695 | Sham Soondree, F. . . . .      |                               |                                            |                                           |
| 696 | Suhunjna ke beej . . . . .     |                               |                                            | Hyperanthera moringa.                     |
| 697 | Seb. . . . .                   |                               |                                            | Malus communis.                           |
| 698 | Seesaliyoon . . . . .          |                               |                                            | Umbelliferae.                             |
| 699 | Semb, F. . . . .               |                               |                                            | Leguminosæ.                               |
| 700 | Send, F. . . . .               |                               |                                            | Cucurbitacæa.                             |
| 701 | Shakhun . . . . .              | Urhur . . . . .               | India . . . . .                            | Cytisus bicolor.                          |
| 702 | Shakhun . . . . .              | Tor . . . . .                 |                                            | Cytisus lajau.                            |
| 703 | Shaneh dushtee . . . . .       |                               |                                            | Sida indica.                              |

| No. | —                            | Synonyms.                   | Places whence Obtained.      | Scientific Names, &c.          |
|-----|------------------------------|-----------------------------|------------------------------|--------------------------------|
| 704 | Shahtureh, St.               |                             |                              |                                |
| 705 | Shair, F.                    | Juo . . . . .               |                              | Barley.                        |
| 706 | Shah husfur . . . . .        | Rihan . . . . .             |                              | Ocymum pilosum.                |
| 707 | Shubit . . . . .             |                             |                              | Anethum sowa.                  |
| 708 | Shubbo nak . . . . .         | Urloo . . . . .             | India . . . . .              | Bignonia indica.               |
| 709 | Shurbuttee . . . . .         |                             |                              | Oryum?                         |
| 710 | Shureefa . . . . .           |                             |                              | Custard apple, Anona squamosa. |
| 711 | Shookakae.                   |                             |                              |                                |
| 712 | Shulgum . . . . .            |                             | Turnip . . . . .             | Brassia rapa.                  |
| 713 | Shuogund . . . . .           |                             | Himalayas.                   |                                |
| 714 | Shounee . . . . .            | Kalonjee . . . . .          |                              | Nigella indica.                |
| 715 | Zuur Satur, St.              |                             |                              |                                |
| 716 | Sunobur . . . . .            | Chilgoza and St.            | Himalayas . . . . .          | Pinus (Neoza) Gerardiana.      |
| 717 | Sundul soorkh . . . . .      | Ruckut chundun . . . . .    |                              | Adenanthora pavonina.          |
| 718 | Adus . . . . .               |                             | Mussooree . . . . .          | Eryum hirsutum.                |
| 719 | Anab . . . . .               |                             | Cashmere . . . . .           | Zizyphus.                      |
| 720 | Anab ool salib . . . . .     |                             |                              | Solanum nigrum.                |
| 721 | Aod suleeb, F.               |                             | Peshawur from Iran.          |                                |
| 722 | Tookhm Ghafis.               |                             |                              |                                |
| 723 | Gool Ghafis . . . . .        |                             | Agrimony . . . . .           | Compositae.                    |
| 724 | Faghereh . . . . .           |                             | Himalayas . . . . .          | Xanthoxylon.                   |
| 725 | Fuji . . . . .               |                             | India . . . . .              | Radish, Raphames sativus.      |
| 726 | Furunj mooshk.               |                             |                              |                                |
| 727 | Furunj mooshk, 2nd sort.     |                             |                              |                                |
| 728 | Furunj mooshk, 3rd sort.     |                             |                              |                                |
| 729 | Pistuk . . . . .             | Pista . . . . .             | Caubul.                      |                                |
| 730 | Gool Pista, F.               |                             | Umritseer.                   |                                |
| 731 | Fiturasaliyoon, F.           |                             |                              | Prangos pabularia.             |
| 732 | Fiturasaliyoon . . . . .     | Another kind.               |                              |                                |
| 733 | Filfil abiuz . . . . .       |                             | White pepper . . . . .       | Piper nigrum.                  |
| 734 | Filfil uswud . . . . .       |                             | Black pepper . . . . .       | Piper nigrum.                  |
| 735 | Fooful . . . . .             |                             | Bengal betle nut . . . . .   | Areca Catechu.                 |
| 736 | Foful Dukhnee, F.            | Chiknee soopiaree . . . . . |                              | Areca.                         |
| 737 | Fofil Duknee, or Hindee, St. |                             |                              |                                |
| 738 | Kakleh saghar . . . . .      | Chotee elachee . . . . .    | Malabar cardamoms . . . . .  | Elettaria cardamomum.          |
| 739 | Kakleh Kubar . . . . .       |                             | Bengal cardamoms . . . . .   | Alpinia?                       |
| 740 | Kissah . . . . .             | Kukree . . . . .            |                              | Cucumis utilitissimus.         |
| 741 | Kussud . . . . .             | Kheera . . . . .            | Cucumber . . . . .           | Cucumis sativus.               |
| 742 | Kheera Kherah, F.            |                             |                              |                                |
| 743 | Tukhm Badrunj, St.           |                             |                              | Cucumis.                       |
| 744 | Kirdmana.                    |                             |                              |                                |
| 745 | Kirdmana, 2nd . . . . .      |                             | Surat.                       |                                |
| 746 | Kiraseca . . . . .           |                             | Cherry . . . . .             | Pruus Cerasus.                 |
| 747 | Kira . . . . .               | Kuddoo tulkh.               |                              |                                |
| 748 | Kira, 2nd, F.                | Kuddoo meetha.              |                              |                                |
| 749 | Kootun . . . . .             | Bunola . . . . .            | Cotton . . . . .             | Gossypium indicum.             |
| 750 | Kootun Bagheeche . . . . .   |                             | New Orleans cotton . . . . . | Gossypium barbadense.          |
| 751 | Kumbela . . . . .            |                             |                              | Rottlera tinctoria.            |
| 752 | Kajoophul . . . . .          |                             |                              |                                |
| 753 | Kakunj . . . . .             |                             |                              |                                |
| 754 | Kakunj peshanree.            |                             |                              |                                |
| 755 | Kakunj, F.                   |                             |                              | Solanum.                       |
| 756 | Ka Peru, St.                 |                             |                              | Serratula anthelmintica.       |
| 757 | Kalee zeeree . . . . .       |                             | Himalayas . . . . .          |                                |
| 758 | Kana bij, St.                |                             |                              |                                |
| 759 | Kubab cheenee . . . . .      |                             |                              | Piper Cubeba.                  |
| 760 | Kutan . . . . .              | Ulsee . . . . .             |                              | Linum usitatissimum.           |
| 761 | Kutae buzoorg . . . . .      |                             |                              | Solanum indicum.               |
| 762 | Kutuelee, F.                 |                             |                              | Solanum.                       |
| 763 | Kuthi Khoord . . . . .       | Kuthuelee . . . . .         |                              | Solanum Jacquinii.             |
| 764 | Kutura . . . . .             |                             |                              |                                |
| 765 | Kuthul . . . . .             |                             |                              | Artocarpus integrifolia.       |
| 766 | Kuchera, F.                  |                             |                              | Cucumis?                       |
| 767 | Korras . . . . .             | Peeazee . . . . .           |                              | Allium porrum.                 |
| 768 | Kurufs . . . . .             |                             | Room . . . . .               | Apium graveolens.              |
| 769 | Kirmulee . . . . .           |                             | Dehli.                       |                                |
| 770 | Kirvia . . . . .             |                             | Subs. for Carum carui        |                                |
| 771 | Karela . . . . .             |                             | India . . . . .              | Cueurbitacea.                  |
| 772 | Kurheey . . . . .            |                             |                              |                                |
| 773 | Kuzeereh . . . . .           | Dhunya . . . . .            | India . . . . .              | Coriandrum sativum.            |
| 774 | Kuchorie . . . . .           |                             |                              |                                |
| 775 | Kussonndhee, F.              |                             |                              | Cassia sophora.                |
| 776 | Kisteh . . . . .             |                             |                              | Apnil?                         |
| 777 | Kisht bur Kisht . . . . .    | Muen phullee . . . . .      |                              | Helicteres scabra.             |
| 778 | Kusoos . . . . .             | Ughas bel ke beej . . . . . | Caubul . . . . .             | Cuscuta.                       |
| 779 | Kushoos, St.                 |                             |                              | Cuscuta.                       |
| 780 | Kulhuttee, St.               |                             |                              |                                |
| 781 | Kulhuttee, St.               |                             | White kind.                  |                                |
| 782 | Kumazrioos.                  |                             |                              |                                |
| 783 | Kumangla . . . . .           |                             |                              |                                |
| 784 | Kumoon . . . . .             | Zeera seeah . . . . .       | Kunawur . . . . .            | Carum nigrum.                  |
| 785 | Kumoon suffed . . . . .      |                             | Cumin . . . . .              | Cuminum Cuminum.               |
| 786 | Kunkoth . . . . .            | Lungett . . . . .           | Dehli . . . . .              | Ximenia ægyptiaca.             |
| 787 | Kunkol mirch . . . . .       |                             | Dukhun.                      |                                |

| No. | —                             | Synonyms.                      | Places whence Obtained. | Scientific Names, &c.          |
|-----|-------------------------------|--------------------------------|-------------------------|--------------------------------|
| 788 | Kunkol mirch . . . . .        |                                | Dukhun.                 |                                |
| 789 | Kunowcheh . . . . .           | Ki <sup>o</sup> anch . . . . . | India . . . . .         | Carpogon pruriens.             |
| 790 | Koonchee . . . . .            |                                | India.                  |                                |
| 791 | Koonchee.                     |                                |                         | Leguminosæ.                    |
| 792 | Kunotha? . . . . .            |                                | Bengal . . . . .        | Leguminosæ.                    |
| 793 | Kunotha? suffed . . . . .     |                                | Bengal . . . . .        | Leguminosæ.                    |
| 794 | Koonchee.                     |                                |                         |                                |
| 795 | Kungnee . . . . .             |                                |                         | Panicum miliaceum.             |
| 796 | Koda, F. . . . .              |                                | Saharunpore . . . . .   | Paspalum serotialatum.         |
| 797 | Kawul gutta, F. . . . .       |                                |                         | Nelubium speciosum.            |
| 798 | Khush Khush . . . . .         |                                |                         | Poppyhead.                     |
| 799 | Kirnee, F. . . . .            |                                |                         | Minusops Elengi.               |
| 800 | Kuhodia metha.                |                                |                         |                                |
| 801 | Kuhodia methce . . . . .      | Kuel ka kullee.                |                         |                                |
| 802 | Kueth . . . . .               |                                | India . . . . .         | Feronia elephantum.            |
| 803 | Kunsonla . . . . .            |                                | Patna.                  |                                |
| 804 | Kinro, St.                    |                                |                         |                                |
| 805 | Kinro, St.                    |                                |                         |                                |
| 806 | Gowmadur, St.                 |                                |                         |                                |
| 807 | Hubool triunch.               |                                |                         |                                |
| 808 | Guj peepul . . . . .          |                                |                         | Pothas.                        |
| 809 | Gul mishkun . . . . .         |                                |                         | Pterospermum.                  |
| 810 | Gundunah, F. . . . .          |                                |                         | Anthericum.                    |
| 811 | Goondar phul, St.             |                                |                         |                                |
| 812 | Gehoonle.                     |                                |                         |                                |
| 813 | Ghoonchee suffed . . . . .    |                                |                         | Abrus precatorius.             |
| 814 | Ghonchee seul.                |                                |                         |                                |
| 815 | Lajwuntee . . . . .           |                                | India . . . . .         | Mimosa.                        |
| 816 | Lissan ool Huml . . . . .     | Bartung.                       |                         |                                |
| 817 | Lissan ool Asafeer.           |                                |                         |                                |
| 818 | Lowz . . . . .                | Badam i shereen . . . . .      | Caubul . . . . .        | Amygdalus communis.            |
| 819 | Lowz . . . . .                | Badam i tulkh . . . . .        | Caubul . . . . .        | Amygdalus communis var. amara. |
| 820 | Mal kungnee . . . . .         |                                |                         | Celastrus nutans.              |
| 821 | Mahlib, St. Scindee . . . . . | Gowla in Bombay, St.           |                         |                                |
| 822 | Mahmoodah, St.                |                                |                         |                                |
| 823 | Mahee zuhuruj . . . . .       |                                |                         | Cocculus indicus.              |
| 824 | Muttur mushung, F.            |                                |                         |                                |
| 825 | Murshahy . . . . .            |                                |                         | Ipomæa.                        |
| 826 | Mirch soohh . . . . .         |                                |                         | Capsicum frutescens.           |
| 827 | Moomiyæ, St.                  |                                |                         |                                |
| 828 | Mukoh, F. . . . .             |                                |                         | Solanum indicum?               |
| 829 | Mukur zullee.                 |                                |                         |                                |
| 830 | Mukhareh . . . . .            |                                |                         | Euryale ferox.                 |
| 831 | Mundwa . . . . .              |                                |                         | Eleusine.                      |
| 832 | Motha . . . . .               |                                | Saharunpore . . . . .   | Phaseolus.                     |
| 833 | Moong . . . . .               |                                | Saharunpore . . . . .   | Phaseolus.                     |
| 834 | Wood.                         |                                |                         |                                |
| 835 | Nargeel . . . . .             |                                |                         | Cocos nucifera.                |
| 836 | Nag kesur . . . . .           | Narmooshk . . . . .            |                         | Mesua ferrea.                  |
| 837 | Nag kesur, St. . . . .        |                                |                         | Cassia buds.                   |
| 838 | Narunga.                      |                                |                         |                                |
| 839 | Nankwah . . . . .             | Ujwain . . . . .               |                         | Ligusticum ujwain.             |
| 840 | Wapomba, St.                  |                                |                         | Careya arborea.                |
| 841 | Nernullee . . . . .           |                                |                         | Strychnos potatorum.           |
| 842 | Noog . . . . .                | Kala til and Ramtil . . . . .  | Abyssinia . . . . .     | Guizotia oliefera.             |
| 843 | Neemb . . . . .               |                                |                         | Melia Azadirachta.             |
| 844 | Ward . . . . .                | Goolab . . . . .               |                         | Rosa Damascena.                |
| 845 | Wunga Tukhm, St.              |                                |                         | Cucurbitacæe.                  |
| 846 | Wusari Meuh, St               |                                |                         |                                |
| 847 | Halim, F. . . . .             |                                |                         | Lepidium.                      |
| 848 | Hoolhool . . . . .            |                                |                         | Cleome pentaphylla.            |
| 849 | Hulyoon . . . . .             |                                |                         | Asparagus officinalis.         |
| 850 | Hulyoon Tookhm.               |                                |                         |                                |

## GALLS.

|     |                             |                      |                  |                     |
|-----|-----------------------------|----------------------|------------------|---------------------|
| 851 | Buz-ghunj . . . . .         |                      |                  | Pistachia galls.    |
| 852 | Khimsuh . . . . .           |                      |                  | Pistachia.          |
| 853 | Mahee.                      |                      |                  |                     |
| 854 | Sakun, St. . . . .          |                      |                  | Tamarisk.           |
| 855 | Mahee Khoord.               |                      |                  |                     |
| 856 | Sumrut ool toorfa . . . . . | Buree muce . . . . . |                  | Tamarisk.           |
| 857 | Mue.                        |                      |                  |                     |
| 858 | Sumur Kokla . . . . .       |                      | Poorub.          |                     |
| 859 | Shukur teeghal . . . . .    |                      |                  | Asclepias gigantea. |
| 860 | Ufus nijjer phul . . . . .  |                      |                  | Quercus.            |
| 861 | Kakra singee . . . . .      |                      | Kalsee . . . . . | Rhus.               |
| 862 | Kakra singhee.              |                      |                  |                     |

## GUMS, RESINS, AND GUM RESINS.

| No. | —                               | Synonyms.                   | Places whence Obtained.     | Scientific Names, &c.                                |
|-----|---------------------------------|-----------------------------|-----------------------------|------------------------------------------------------|
| 863 | Ooshuk (ammoniacum)             | Kandurooskh . . . .         | Caubul . . . . .            | Dorema ammoniacum.                                   |
| 864 | Unzeroot . . . . .              | Sarcocolla . . . . .        | Surat Hills . . . . .       | Penæa Sarcocolla.                                    |
| 865 | Bar-zud birceja . . . . .       | Galbanum . . . . .          | Surat Hills . . . . .       | Bubon Galbanum.                                      |
| 866 | Puddum ke gond . . . . .        | . . . . .                   | S. B. G. Hills . . . . .    | Prunus puddum.                                       |
| 867 | Puchdhara gond . . . . .        | . . . . .                   | S. B. G. . . . .            | Euphorbia antequorum.                                |
| 868 | Toorunjbeen . . . . .           | Persian manna . . . . .     | Caubul . . . . .            | Alhaji Maurorum.                                     |
| 869 | Toon ke gond . . . . .          | . . . . .                   | India . . . . .             | Cedrela Toona.                                       |
| 870 | Huzeez Mukke . . . . .          | A kind of benzoin . . . . . | Surat . . . . .             | . . . . .                                            |
| 871 | Jawasheer . . . . .             | Opoponax . . . . .          | Arabia . . . . .            | Pastinaca Opoponax.                                  |
| 872 | Jingun ke gond . . . . .        | Kunnee gond . . . . .       | Khera Pass . . . . .        | Icica resinifera.                                    |
| 873 | Dum ool Akhwain . . . . .       | Dragon's blood . . . . .    | Surat. Arabia . . . . .     | Dracæna Draco. Calamus Rotang.<br>Pterocarpus Draco. |
| 874 | Rateeanuj . . . . .             | Colophony . . . . .         | Surat. . . . .              | . . . . .                                            |
| 875 | Zoofit . . . . .                | Resin . . . . .             | Room. . . . .               | . . . . .                                            |
| 876 | Saleh ke gond . . . . .         | Koondur . . . . .           | Khera . . . . .             | Boswellia serrata.                                   |
| 877 | Sukmoonya . . . . .             | Scammony . . . . .          | Surat . . . . .             | Convolvulus Scammonia.                               |
| 878 | Sukmoonya, 2nd . . . . .        | . . . . .                   | Surat. . . . .              | . . . . .                                            |
| 879 | Sukbeenuj . . . . .             | Sagapenum . . . . .         | Arabia . . . . .            | Ferula persica.                                      |
| 880 | Soondroos . . . . .             | Copal . . . . .             | Marwar. . . . .             | . . . . .                                            |
| 881 | Soondroos, 2nd . . . . .        | . . . . .                   | Africa. . . . .             | . . . . .                                            |
| 882 | Sohunje ke gond . . . . .       | . . . . .                   | India . . . . .             | Hyperanthera Moringa.                                |
| 883 | Siriss ke gond . . . . .        | . . . . .                   | India . . . . .             | Mimosa Serissa.                                      |
| 884 | Sem ke gond . . . . .           | Gota gond . . . . .         | Deyra and Rappore . . . . . | Bauhinia gummifera.                                  |
| 885 | Sembul ke gond . . . . .        | Mochrus . . . . .           | India . . . . .             | Bombax heptaphylla.                                  |
| 886 | Elwa . . . . .                  | . . . . .                   | . . . . .                   | Aloa perfoliata.                                     |
| 887 | Ungoor ke gond . . . . .        | . . . . .                   | . . . . .                   | Vitis vinifera.                                      |
| 888 | Sumugh Araba . . . . .          | . . . . .                   | Arabia . . . . .            | Acacia vera.                                         |
| 889 | Ulk-ool-butlum . . . . .        | Chio turpentine . . . . .   | Surat . . . . .             | Pistacia Terebinthus Umritseer.                      |
| 890 | Firfiyom . . . . .              | Euphorbium . . . . .        | Arabia . . . . .            | Euphorbia.                                           |
| 891 | Karch . . . . .                 | Ral . . . . .               | Kherce . . . . .            | Shorea robusta.                                      |
| 892 | Kirasia . . . . .               | Cherrygum . . . . .         | Surat . . . . .             | Prunus Cerasus.                                      |
| 893 | Kuteera . . . . .               | Gond . . . . .              | Khera Pass . . . . .        | Bombax gessypinum.                                   |
| 894 | Koondur olibanum . . . . .      | Loban . . . . .             | Surat . . . . .             | Cochlospermum.                                       |
| 895 | Koondur olibanum, 2nd . . . . . | . . . . .                   | Poonub. . . . .             | . . . . .                                            |
| 896 | Kunnee gond. . . . .            | . . . . .                   | . . . . .                   | . . . . .                                            |
| 897 | Kumurkus . . . . .              | Dhak ke gond . . . . .      | India . . . . .             | Butea frondosa.                                      |
| 898 | Koondroo . . . . .              | Saleh ke gond . . . . .     | Almora . . . . .            | Boswellia serrata.                                   |
| 899 | Khuer ke gond . . . . .         | . . . . .                   | Deyra . . . . .             | Acacia Catechu.                                      |
| 900 | Googlee . . . . .               | . . . . .                   | Hills. . . . .              | . . . . .                                            |
| 901 | Ladun . . . . .                 | Labdanum . . . . .          | Surat . . . . .             | Cistus ladaniferus.                                  |
| 902 | Look . . . . .                  | Gum lac . . . . .           | Deyra, &c. . . . .          | Coccus lacca.                                        |
| 903 | Moor (bol) . . . . .            | Myrrh . . . . .             | Surat . . . . .             | Balsamodandra.                                       |
| 904 | Zurdaloo . . . . .              | Kegond . . . . .            | S. B. G. Hills . . . . .    | Prunus choooloo.                                     |
| 905 | Mustagee . . . . .              | Mastick . . . . .           | Caubul . . . . .            | Pistacia lentiscus.                                  |
| 906 | Mookul . . . . .                | Googul Bdeillum . . . . .   | . . . . .                   | Amyris agolleche.                                    |
| 907 | Mookul, 2nd. . . . .            | Googul, 2nd. . . . .        | Hills. . . . .              | . . . . .                                            |
| 908 | Naguoree gond. . . . .          | . . . . .                   | Nagora . . . . .            | Alalle archea.                                       |
| 909 | Nishasteh . . . . .             | . . . . .                   | Mirzapore. . . . .          | . . . . .                                            |

## MINERAL KINGDOM.

|    |                          |                                                        |                       |                                            |
|----|--------------------------|--------------------------------------------------------|-----------------------|--------------------------------------------|
| 1  | Abar . . . . .           | { Seesa ke rakh.<br>Seesa jullahoon<br>(burnt lead.) } | India . . . . .       | Oxide of lead.                             |
| 2  | Ulree . . . . .          | Yellow tertiary . . . . .                              | Juepore . . . . .     | Limestone.                                 |
| 3  | Ulree, 2nd. . . . .      | . . . . .                                              | Surat . . . . .       | Limestone.                                 |
| 4  | Ubkur . . . . .          | Shora . . . . .                                        | India . . . . .       | Nitrate of potash.                         |
| 5  | Uswud . . . . .          | Soormee . . . . .                                      | Kurpaul . . . . .     | Sulphuret of lead.                         |
| 6  | Uswud, 2nd. . . . .      | Soorma . . . . .                                       | Caubul . . . . .      | Sulphuret of antimony.                     |
| 7  | Ustwuud suffed . . . . . | Soorma suffed . . . . .                                | Caubul . . . . .      | Calcareous spar.                           |
| 8  | Ajur . . . . .           | Purance aent ke khora . . . . .                        | India . . . . .       | Old bricks impregnated with saline matter. |
| 9  | Isfidaj . . . . .        | Suffeda . . . . .                                      | Furruka bad . . . . . | White lead.                                |
| 10 | Isfidaj, 2nd . . . . .   | { Suffeda kash. kuncce.<br>— kas kurce. v. }           | Surat. . . . .        | . . . . .                                  |
| 11 | Ermanee . . . . .        | . . . . .                                              | Surat . . . . .       | Serpentine opal.                           |
| 12 | Barood . . . . .         | . . . . .                                              | India . . . . .       | Gunpowder.                                 |
| 13 | Bokhrar . . . . .        | . . . . .                                              | Surat . . . . .       | Opal, striped.                             |
| 14 | Birunj . . . . .         | Pectul . . . . .                                       | India . . . . .       | Brass.                                     |
| 15 | Birorj . . . . .         | . . . . .                                              | Tanktoda . . . . .    | Selenite.                                  |
| 16 | Bilor . . . . .          | . . . . .                                              | Dehlee . . . . .      | Quartz crystal.                            |
| 17 | Bilor, 2nd . . . . .     | . . . . .                                              | Pegu . . . . .        | Calcareous spar.                           |
| 18 | Borruk . . . . .         | Booreh yermanee . . . . .                              | Arabia . . . . .      | . . . . .                                  |
| 19 | Bhurut . . . . .         | . . . . .                                              | Surat . . . . .       | Green carbonate of lime.                   |
| 20 | Pa . . . . .             | . . . . .                                              | Dukhun . . . . .      | Fibrous alum with green sulphate of iron.  |
| 21 | Padzuhr . . . . .        | Zuhr, mohra . . . . .                                  | Calcutta . . . . .    | Serpentine, v. Herbert's acct.             |

| No. | —                                | Synonyms.                      | Places whence Obtained.    | Scientific Names, &c.                                             |
|-----|----------------------------------|--------------------------------|----------------------------|-------------------------------------------------------------------|
| 22  | Padzuhr suffed . . . . .         | Suffed zuhr. mohra . . . . .   | Surat . . . . .            | Lithomarge.                                                       |
| 23  | Padzuhr seeah . . . . .          | Seah zuhr. mohra . . . . .     | Benares . . . . .          | Dark-green serpentine.                                            |
| 24  | Patoonia . . . . .               | . . . . .                      | Khimas . . . . .           | Heliotrope.                                                       |
| 25  | Patoonia, 2nd. . . . .           | . . . . .                      | Surat . . . . .            | Serpentine.                                                       |
| 26  | Pisla . . . . .                  | . . . . .                      | Kangra . . . . .           | Green felspar.                                                    |
| 27  | Paluta . . . . .                 | . . . . .                      | Juepore . . . . .          | Bloodstone.                                                       |
| 28  | Pulewa . . . . .                 | . . . . .                      | Juepore . . . . .          | Clay slate.                                                       |
| 29  | Pindol . . . . .                 | . . . . .                      | Chilkhana . . . . .        | White clay.                                                       |
| 30  | Pokhraj . . . . .                | . . . . .                      | Surat . . . . .            | Opal beryl?                                                       |
| 31  | Peoree . . . . .                 | . . . . .                      | Hatrass . . . . .          | Light clay coloured by vegetable matter.                          |
| 32  | Toormulee zurd . . . . .         | . . . . .                      | Surat . . . . .            |                                                                   |
| 33  | Tourmulee, 2nd. . . . .          | . . . . .                      | Surat . . . . .            |                                                                   |
| 34  | Toormulee, 3rd. . . . .          | . . . . .                      | Pegu . . . . .             |                                                                   |
| 35  | Tourmulee subz . . . . .         | . . . . .                      | Pegu . . . . .             |                                                                   |
| 36  | Tourmulee suffed . . . . .       | . . . . .                      | Pegu . . . . .             |                                                                   |
| 37  | Tourmulee suffed . . . . .       | . . . . .                      | Surat . . . . .            |                                                                   |
| 38  | Tourmulee seeah . . . . .        | . . . . .                      | Pegu . . . . .             |                                                                   |
| 39  | Tilliur puthur . . . . .         | . . . . .                      | Kassypore . . . . .        | Hornblende quartz.                                                |
| 40  | Tincal . . . . .                 | Sohaga . . . . .               | Noodurpore . . . . .       | Borax.                                                            |
| 41  | Tincal, 2nd. . . . .             | Sohaga tellia (oily) . . . . . | Noodurpore . . . . .       | Borax.                                                            |
| 42  | Tobal . . . . .                  | Muel tambak . . . . .          | India . . . . .            | Dross of copper.                                                  |
| 43  | Tootyia . . . . .                | Neela thothia . . . . .        | Marwar . . . . .           | Sulphate of copper.                                               |
| 44  | Tootyia haroonee . . . . .       | . . . . .                      | Arabia . . . . .           |                                                                   |
| 45  | Tootyia subz . . . . .           | Goozuratee . . . . .           | Guzerat . . . . .          |                                                                   |
| 46  | Tippus . . . . .                 | . . . . .                      | Surat . . . . .            |                                                                   |
| 47  | Juokbar . . . . .                | . . . . .                      | Dehlee . . . . .           | Carbonate of potash.                                              |
| 48  | Choonee pl. choonya . . . . .    | . . . . .                      | Surat . . . . .            | Spinel ruby.                                                      |
| 49  | Hijr (stone) . . . . .           | No name . . . . .              | Surat . . . . .            | Graphite.                                                         |
| 50  | Hijr-urmunee . . . . .           | . . . . .                      | Arabia . . . . .           | Red jasper.                                                       |
| 51  | Hijr-ool-hudeed . . . . .        | . . . . .                      | Caubul . . . . .           | Iron ore.                                                         |
| 52  | Hijr-ool-hudeed, 2nd. . . . .    | . . . . .                      | Hills . . . . .            | Iron ore.                                                         |
| 53  | ? . . . . .                      | . . . . .                      | Surat . . . . .            | Iron ore.                                                         |
| 54  | Hijr-ool-sitar . . . . .         | Sung sitara . . . . .          | Surat . . . . .            | Avanturine?                                                       |
| 55  | Hijr-ool-sitar, 2nd . . . . .    | . . . . .                      | Dehlee, B. . . . .         |                                                                   |
| 56  | Hijr-ool-simak . . . . .         | . . . . .                      | Dukhun . . . . .           | Granite porphyritic.                                              |
| 57  | Hijr-ool-simak . . . . .         | Oonabee . . . . .              | Dukhun . . . . .           | Porphyry.                                                         |
| 58  | Hijr-ool-simak . . . . .         | Kirmizee . . . . .             | Mecca . . . . .            | Porphyritic jasper.                                               |
| 59  | Hijr-ool-ajalb . . . . .         | . . . . .                      | Surat . . . . .            | Milky quartz.                                                     |
| 60  | Hijr-ool-Eesa . . . . .          | . . . . .                      | Dehlee, B. . . . .         | Serpentine.                                                       |
| 61  | Hijr-ool-khuttoo . . . . .       | . . . . .                      | Surat . . . . .            | Limestone (Jesselmere limestone).                                 |
| 62  | Hijr-ool-mahuk . . . . .         | Kusoutee . . . . .             | Dukhun . . . . .           | Touchstone (flinty slate).                                        |
| 63  | Hijr-ool-murium . . . . .        | . . . . .                      | Dehlee, B. . . . .         | Tertiary limestone v. Voyagey, used in tomb of Secundra.          |
| 64  | Hijr-ool-murium, 2nd . . . . .   | . . . . .                      | Caubul . . . . .           | Coarse grained quartz.                                            |
| 65  | Hijr-ool-muknatees . . . . .     | Choombuk . . . . .             | Dehlee (Gwalior) . . . . . | Loadstone.                                                        |
| 66  | Hijr-ool-moosa . . . . .         | Tilia koorund . . . . .        | Hurdwar . . . . .          |                                                                   |
| 67  | Hijr-ool-meena . . . . .         | Kanch . . . . .                | Surat . . . . .            | Glass.                                                            |
| 68  | Hijr-ool-meena, 2nd. . . . .     | . . . . .                      | Surat . . . . .            |                                                                   |
| 69  | Hijr-ool-nan . . . . .           | Chukmak . . . . .              | Surat . . . . .            | Quartz, substit. for flints.                                      |
| 70  | Hijr-ool-yusheb . . . . .        | Sung eeshum . . . . .          | Caubul . . . . .           | White compact quartz.                                             |
| 71  | Hijr-ool-yusheb abiuz . . . . .  | Sung eeshum suffed . . . . .   | Caubul . . . . .           | White compact quartz.                                             |
| 72  | Hijr-ool yusheb ukhzur . . . . . | Sung eeshum subz . . . . .     | Caubul . . . . .           | Chalcedonic quartz.                                               |
| 73  | Hijr-ool-Yahodee . . . . .       | Sung yahoodans . . . . .       | Arabia . . . . .           | Lapis judaicus; fossil spine of an echinus.                       |
| 74  | Hudeed . . . . .                 | Kheree loha . . . . .          | Dukhun . . . . .           | Iron of superior quality.                                         |
| 75  | Hudeed ispat . . . . .           | Ispat . . . . .                | Surat . . . . .            | Steel.                                                            |
| 76  | Kharuk . . . . .                 | . . . . .                      | Surat . . . . .            | Crystals of calcareous spar. Chalcedony also given.               |
| 77  | Khirumjee . . . . .              | . . . . .                      | Hills . . . . .            | Quartz pebble.                                                    |
| 78  | Dardoor . . . . .                | . . . . .                      | . . . . .                  | Clay slate.                                                       |
| 79  | Doodhya . . . . .                | . . . . .                      | Surat . . . . .            | White agate.                                                      |
| 80  | Duehnij . . . . .                | Dana frung . . . . .           | Surat . . . . .            | Malachite; acetate of copper.                                     |
| 81  | Dhoonuella . . . . .             | . . . . .                      | Surat . . . . .            | Topaz? smoky quartz.                                              |
| 82  | Dhedhee . . . . .                | . . . . .                      | Surat . . . . .            | Touchstone.                                                       |
| 83  | Rutwad . . . . .                 | . . . . .                      | Surat . . . . .            | Red jasper; red clay-stone.                                       |
| 84  | Ruskupoor . . . . .              | . . . . .                      | Dukhun Poorub . . . . .    | Submuriate of mercury.                                            |
| 85  | Risas abiuz . . . . .            | Ranga . . . . .                | Poorub . . . . .           | Tin.                                                              |
| 86  | Risas usvud . . . . .            | Seesa . . . . .                | Hills . . . . .            | Lead.                                                             |
| 87  | Roosukhtuj . . . . .             | Tamba julla hooa . . . . .     | Surat . . . . .            | Impure oxide of copper.                                           |
| 88  | Rowlee . . . . .                 | . . . . .                      | Dehlee . . . . .           | A compound made with huldee, soap, &c., used in making the tikka. |
| 89  | Rooee . . . . .                  | Kansee . . . . .               | India . . . . .            | Bell metal.                                                       |
| 90  | Zubur jud . . . . .              | . . . . .                      | Surat . . . . .            | Impure emerald.                                                   |
| 91  | Zijaj . . . . .                  | Kanch . . . . .                | India . . . . .            | Glass.                                                            |
| 92  | Zurneeekh suffed . . . . .       | . . . . .                      | Poorub . . . . .           | Selenite.                                                         |
| 93  | Zurneeekh soorkh . . . . .       | Munsul . . . . .               | Dukhun . . . . .           | Red orpiment; red sulphuret of arsenic.                           |
| 94  | Zurneeekh zurd . . . . .         | Hurtal . . . . .               | Dukhun . . . . .           | Yellow orpiment.                                                  |
| 95  | Zurneeekh tubkee . . . . .       | Yellow . . . . .               | Dukhun . . . . .           | Yellow realgar.                                                   |
| 96  | Zumurood . . . . .               | . . . . .                      | Patna . . . . .            | Emerald.                                                          |
| 97  | Zumurood toddee . . . . .        | . . . . .                      | Herat . . . . .            | Emerald, or cat's eye?                                            |
| 98  | Zinjar . . . . .                 | Zungar . . . . .               | Agra . . . . .             | Verdigrise.                                                       |



| No. | —                              | Synonyms.                       | Places whence Obtained.              | Scientific Names, &c.                                                                    |
|-----|--------------------------------|---------------------------------|--------------------------------------|------------------------------------------------------------------------------------------|
| 99  | Zunjufr . . . . .              | Shungruf . . . . .              | Poorub . . . . .                     | Cinnabar.                                                                                |
| 100 | Sar . . . . .                  | Foulad kooshteh . . . . .       | India . . . . .                      | Oxide of iron.                                                                           |
| 101 | Shijree . . . . .              |                                 | Surat . . . . .                      | Chalcedonic pebble.                                                                      |
| 102 | Surunj . . . . .               | Sundoor . . . . .               | Calcutta . . . . .                   | Red lead ; minium.                                                                       |
| 103 | Sulajeet . . . . .             |                                 | Hills . . . . .                      | Bitumen; impure, burns with slight flame.                                                |
| 104 | Sulajeet, 2nd . . . . .        |                                 | Hills . . . . .                      | Coal.                                                                                    |
| 105 | Dar shikna . . . . .           | Soolemance . . . . .            | Surat . . . . .                      | Onyx.                                                                                    |
| 106 | Soolemance . . . . .           |                                 | Surat . . . . .                      | Fibrous alum.                                                                            |
| 107 | Sung-par . . . . .             |                                 | Caubul, Mushapoor . . . . .          | Jet.                                                                                     |
| 108 | Se . . . . .                   |                                 | Surat . . . . .                      | Pot-stone; talcaceous schist?                                                            |
| 109 | Sung saffee . . . . .          |                                 | Dehlee . . . . .                     | Calcareous spar.                                                                         |
| 110 | Sung jurahut . . . . .         | Suffed soorma . . . . .         | Dehlee . . . . .                     | Alum.                                                                                    |
| 111 | Sung jurahut, 2nd . . . . .    |                                 | Hills . . . . .                      | Egyptian stone?                                                                          |
| 112 | Sung misree . . . . .          |                                 | Caubul . . . . .                     | Egyptian stone?                                                                          |
| 113 | Sung Misree, 2nd . . . . .     |                                 | Surat . . . . .                      | Smoky quartz.                                                                            |
| 114 | Sonailah . . . . .             |                                 | Surat . . . . .                      | Talcaceous schist?                                                                       |
| 115 | Set khurree . . . . .          |                                 | Hills . . . . .                      | Carbonate of lime, coloured by carbonate of iron, with a nucleus of calcareous crystals. |
| 116 | Shudnuj udsee . . . . .        |                                 | Arabia . . . . .                     | White alum.                                                                              |
| 117 | Shub yemance abiuz . . . . .   | Phitkhurru suffed . . . . .     | Poorub . . . . .                     | Red alum.                                                                                |
| 118 | Shub yemance ahmur . . . . .   | Phitkhurru soorukh . . . . .    | Peshawur . . . . .                   | Greenish alum.                                                                           |
| 119 | Shub yemance ukhzur . . . . .  | Phitkhurru subz . . . . .       | Reworee . . . . .                    | Zinc.                                                                                    |
| 120 | Shibbeh . . . . .              | Just . . . . .                  | Arabia, Poorub . . . . .             | Oxide of zinc.                                                                           |
| 121 | Shibbeh mohrik . . . . .       | Justjulle hooa . . . . .        | India . . . . .                      | White chalcedony.                                                                        |
| 122 | Shurbuttee . . . . .           |                                 | Caubul . . . . .                     | White oxide of arsenic.                                                                  |
| 123 | Sumb ool far abiuz . . . . .   | Simbul khar suffed . . . . .    | Caubul . . . . .                     | Red sulphuret of arsenic.                                                                |
| 124 | Sumb ool umhur . . . . .       | Simbul khar soorukh . . . . .   | Caubul . . . . .                     | Yellow sulphuret of arsenic.                                                             |
| 125 | Sumb ool usfur . . . . .       | Simbul khar zurd . . . . .      | Caubul . . . . .                     | Lahore soap.                                                                             |
| 126 | Sabon . . . . .                | Lahore . . . . .                | Lahore . . . . .                     | Tabasheer.                                                                               |
| 127 | Tabasheer . . . . .            | Bans lochun . . . . .           | India, Poorub . . . . .              | White mica.                                                                              |
| 128 | Tulk abiuz . . . . .           | Ubruk suffed . . . . .          | Dukhun . . . . .                     | Burnt mica.                                                                              |
| 129 | Tulk kooshteh . . . . .        | Ubruk mara hova . . . . .       |                                      | Black mica.                                                                              |
| 130 | Tulk uswud . . . . .           |                                 | Sermona . . . . .                    | Red clay, or clay slate.                                                                 |
| 131 | Teen umhur . . . . .           | Geero . . . . .                 | Gwalior . . . . .                    | Green earth.                                                                             |
| 132 | Teen ukhzur . . . . .          | Gil subz subz mufttee . . . . . | Dehlee . . . . .                     | Armenian bole? lithomarge.                                                               |
| 133 | Teen armencee . . . . .        | Gil urmune . . . . .            | Arabia . . . . .                     | Yellow clay; lithomarge.                                                                 |
| 134 | Teen Daghistancee . . . . .    |                                 | Surat . . . . .                      | Whitish clay.                                                                            |
| 135 | Teen Gunjune . . . . .         | Mooltanee muttee . . . . .      | Lahore . . . . .                     | Cyprus earth; S. Q. 2, 2, lithomarge, with muriate of soda.                              |
| 136 | Teen Kibrusee . . . . .        |                                 | Surat . . . . .                      | Red clay slate.                                                                          |
| 137 | Teen mukhtoom . . . . .        |                                 | Caubul . . . . .                     | Yellow clay slate.                                                                       |
| 138 | Teen usfur . . . . .           | Zurd muttee . . . . .           | Mooltan . . . . .                    | Variegated limestone, with organic remains.                                              |
| 139 | Ajooba . . . . .               |                                 | Dukhun . . . . .                     | Cornelian.                                                                               |
| 140 | Akeek . . . . .                |                                 | Surat . . . . .                      | Common agate.                                                                            |
| 141 | Akeek, 2nd . . . . .           |                                 | Surat . . . . .                      | White cornelian.                                                                         |
| 142 | Ghoree . . . . .               |                                 | Surat . . . . .                      | Agate.                                                                                   |
| 143 | Ghoree, 2nd . . . . .          |                                 |                                      |                                                                                          |
| 144 | Ghoree, 3rd . . . . .          |                                 |                                      |                                                                                          |
| 145 | Ghoree, 4th . . . . .          |                                 |                                      |                                                                                          |
| 146 | Firosuj . . . . .              |                                 | Bokhara . . . . .                    | Turquoise.                                                                               |
| 147 | Firosuj, 2nd . . . . .         |                                 |                                      |                                                                                          |
| 148 | Kufr ool yahood . . . . .      |                                 | Surat . . . . .                      | Asphaltum; Jew's pitch.                                                                  |
| 149 | Kullee abiuz . . . . .         | Sujjee muttee . . . . .         | Batandur N. of Saharunpore . . . . . | Carbonate of soda.                                                                       |
| 150 | Kullee ahmur, 2nd . . . . .    |                                 |                                      |                                                                                          |
| 151 | Kullee uswud . . . . .         |                                 |                                      |                                                                                          |
| 152 | Kashuree . . . . .             |                                 | Kangra . . . . .                     | Impure Fine-grained slate; argillaceous carbonate of lime.                               |
| 153 | Kashuree, 2nd . . . . .        |                                 | Surat . . . . .                      | Chalcedony.                                                                              |
| 154 | Kibrete cha chia . . . . .     |                                 |                                      | Sulphur.                                                                                 |
| 155 | Kibrete cha chi, 2nd . . . . . |                                 |                                      | Sulphur.                                                                                 |
| 156 | Kibrete mooslee . . . . .      |                                 |                                      | Sulphur, roll.                                                                           |
| 157 | Kibrete nirmula . . . . .      | Sax . . . . .                   | Dukhun . . . . .                     |                                                                                          |
| 158 | Kibrete aonla sar . . . . .    | Gundhuk . . . . .               | Dukhun . . . . .                     | A compound.                                                                              |
| 159 | Kibrete seeah . . . . .        | Kalee gundhuk . . . . .         |                                      |                                                                                          |
| 160 | Kittee . . . . .               |                                 | Bullumgur . . . . .                  | Iron ore.                                                                                |
| 161 | Kurketuk . . . . .             |                                 |                                      | Sapphire.                                                                                |
| 162 | Kusees . . . . .               |                                 | Dehlee . . . . .                     | Green vitriol.                                                                           |
| 163 | Kusees, 2nd . . . . .          |                                 |                                      | Sulphate of iron.                                                                        |
| 164 | Kusees, 3rd . . . . .          |                                 |                                      | Sulphate of iron.                                                                        |
| 165 | Killus . . . . .               | Choonaa . . . . .               | Hills, India . . . . .               | Lime.                                                                                    |
| 166 | Kulwa puthur . . . . .         |                                 | Caubul . . . . .                     | Amethyst; amethystine quartz.                                                            |
| 167 | Kuthuella . . . . .            |                                 | Surat . . . . .                      | Corundum.                                                                                |
| 168 | Koorund . . . . .              |                                 | Benares . . . . .                    | White soapy clay.                                                                        |
| 169 | Khurya muttee . . . . .        |                                 | Poorub . . . . .                     | Compact quartz.                                                                          |
| 170 | Gawa . . . . .                 |                                 | Cashmere . . . . .                   | White clay.                                                                              |
| 171 | Gopee chun dun . . . . .       |                                 | Hurdwar . . . . .                    | Milky quartz.                                                                            |
| 172 | Gomueduc . . . . .             |                                 | Surat . . . . .                      | Serpentine? greenstone.                                                                  |
| 173 | Gao dunta . . . . .            |                                 |                                      | Lapis lazuli.                                                                            |
| 174 | Lajwurd . . . . .              |                                 | Khimas . . . . .                     | Topaz.                                                                                   |
| 175 | Lal suffed . . . . .           |                                 | Surat . . . . .                      |                                                                                          |

| No. | —                            | Synonyms.                | Places whence Obtained. | Scientific Names, &c.                  |
|-----|------------------------------|--------------------------|-------------------------|----------------------------------------|
| 176 | Lal goolabee . . . . .       | . . . . .                | Surat . . . . .         | Corundum.                              |
| 177 | Losinghan . . . . .          | . . . . .                | Caubul . . . . .        | Iron ore.                              |
| 178 | Luchsunya . . . . .          | . . . . .                | Surat . . . . .         | Milky quartz.                          |
| 179 | Luela . . . . .              | . . . . .                | . . . . .               | Coarse garnets.                        |
| 180 | Luelee . . . . .             | . . . . .                | . . . . .               | Felspar.                               |
| 181 | Mar mohuret . . . . .        | . . . . .                | Surat.                  |                                        |
| 182 | Manuk munowur . . . . .      | . . . . .                | Surat . . . . .         | Felspar, red ?                         |
| 183 | Manuk suffed . . . . .       | . . . . .                | Surat . . . . .         | Opal.                                  |
| 184 | Manuk soorkh . . . . .       | . . . . .                | Surat.                  |                                        |
| 185 | Moordar Sung . . . . .       | . . . . .                | India . . . . .         | Litharge; semi-vitreous oxide of lead. |
| 186 | Murksheesha . . . . .        | Sonamukhee . . . . .     | Surat . . . . .         | Schist, with iron pyrites.             |
| 187 | Murkuz . . . . .             | . . . . .                | Furrukhabad.            |                                        |
| 188 | Mushukoonia . . . . .        | Nimuk munyaree . . . . . | India.                  |                                        |
| 189 | Milleh uswud . . . . .       | Kala nimuk . . . . .     | . . . . .               | Black salt.                            |
| 190 | Nushae . . . . .             | Nishasta . . . . .       | India . . . . .         | Starch of wheat.                       |
| 191 | Nosadur . . . . .            | . . . . .                | India . . . . .         | Sal ammoniac.                          |
| 192 | Nosadur puakanee . . . . .   | . . . . .                | Surat . . . . .         | Sal ammoniac.                          |
| 193 | Hadya . . . . .              | . . . . .                | Cashmere . . . . .      | Compact quartz.                        |
| 194 | Hirumjee . . . . .           | . . . . .                | Mooltan.                |                                        |
| 195 | Yakoot Budukshanee . . . . . | . . . . .                | Surat . . . . .         | Ruby.                                  |
| 196 | Yakoot Rumanee . . . . .     | . . . . .                | Surat . . . . .         | Ruby.                                  |
| 197 | Yakoot zurd . . . . .        | . . . . .                | Surat.                  |                                        |
| 198 | Yakoot suffed . . . . .      | . . . . .                | Surat.                  |                                        |
| 199 | Yakoot kirumzee . . . . .    | . . . . .                | Surat . . . . .         | Green felspar.                         |
| 200 | Yakoot nubood . . . . .      | . . . . .                | Surat . . . . .         | Sapphire.                              |
| 201 | Yakoot nubood, 2nd . . . . . | . . . . .                | Surat . . . . .         | Sapphire.                              |
| 202 | Yakoot . . . . .             | . . . . .                | Keju.                   |                                        |

## ANIMAL KINGDOM.

|    |                               |                            |                        |                                   |
|----|-------------------------------|----------------------------|------------------------|-----------------------------------|
| 1  | Uz far ool teeb . . . . .     | Nukh . . . . .             | Surat . . . . .        | Unguis odoratus; black Byzantine. |
| 2  | Padzahr huewane . . . . .     | Zuhr mohreh . . . . .      | India, Surat . . . . . | Bezoar.                           |
| 3  | Bussud suffed . . . . .       | Moonga ke zur . . . . .    | Surat . . . . .        | Coral.                            |
| 4  | Bussud suffed, 2nd . . . . .  | Bekh moor jar . . . . .    | Dukhun.                |                                   |
| 5  | Bussud suffed, 3rd . . . . .  | . . . . .                  | Surat.                 |                                   |
| 6  | Shakh Moorjan . . . . .       | . . . . .                  | Surat.                 |                                   |
| 7  | Shakh Moorjan, 2nd . . . . .  | . . . . .                  | Surat.                 |                                   |
| 8  | Busud ke kism . . . . .       | . . . . .                  | Dukhun.                |                                   |
| 9  | Jubun . . . . .               | Puneer . . . . .           | Caubul . . . . .       | Cheese.                           |
| 10 | Goond bedustur . . . . .      | . . . . .                  | . . . . .              | Castor.                           |
| 11 | Hijr ool hool . . . . .       | Sung. siri mahee . . . . . | Dehlee.                |                                   |
| 12 | Dod ool hurcer . . . . .      | . . . . .                  | Poorub . . . . .       | Silk-worm cocoon.                 |
| 13 | Dhal shootier . . . . .       | . . . . .                  | Caubul . . . . .       | Cheese of camel's milk.           |
| 14 | Roob mahee . . . . .          | Mahee . . . . .            | Surat . . . . .        | Mirzapore.                        |
| 15 | Zoobd ool buhr . . . . .      | Sumundur jhug . . . . .    | Surat . . . . .        | Cuttle-fish bone.                 |
| 16 | Shuma . . . . .               | Mom . . . . .              | India . . . . .        | Wax.                              |
| 17 | Suduf . . . . .               | Seemp . . . . .            | Surat . . . . .        | Shell.                            |
| 18 | Hijr ool dek . . . . .        | . . . . .                  | India.                 |                                   |
| 19 | Ghurrea ool jullood . . . . . | Sirep . . . . .            | India . . . . .        | Glue.                             |
| 20 | Kuchroba . . . . .            | . . . . .                  | Poorub . . . . .       | Amber.                            |
| 21 | Gao lochun . . . . .          | . . . . .                  | Surat.                 |                                   |
| 22 | Geedur soondee . . . . .      | Jackal's navel . . . . .   | India . . . . .        | Nest of Mantis.                   |
| 23 | Loloo . . . . .               | Mothee . . . . .           | Surat . . . . .        | Pearl.                            |
| 24 | Loloo . . . . .               | . . . . .                  | Surat.                 |                                   |
| 25 | Loloo zurd . . . . .          | . . . . .                  | Surat.                 |                                   |
| 26 | Loloo seah . . . . .          | . . . . .                  | Surat.                 |                                   |
| 27 | Loloo seah, 2nd . . . . .     | . . . . .                  | Surat.                 |                                   |
| 28 | Loloo seah khan . . . . .     | Mothee pucka . . . . .     | Surat.                 |                                   |
| 29 | Loloo seah goolaba . . . . .  | . . . . .                  | Surat.                 |                                   |
| 30 | Merjan . . . . .              | Moonga . . . . .           | . . . . .              | Coral.                            |
| 31 | Nafe moochk bila . . . . .    | . . . . .                  | Nepal.                 |                                   |
| 32 | Mac shootur . . . . .         | . . . . .                  | Arabia.                |                                   |
| 33 | Kustoora . . . . .            | . . . . .                  | Bengal.                |                                   |

## MACHINERY.

## CLASS V.—Machines for direct use, including Carriages.

Model of a coin-sorting machine, from the Mint at Madras, according to Major Smith's plan.

Bamboo hackery; hackery wheels; axle and sockets for the same.

Native cart, hackery. This sort of cart is used throughout Lower Bengal, and particularly in commercial towns for the transport of goods. It is remarkable for its extraordinary strength, being equal to a load of several tons. The wheels are made of babool or *Acacia Arabica*, the axle of sunderee or *Heritiera minor*, the stocks for the

same of Asun wood, and the framework and yoke of bamboo. The axles are seldom oiled or greased, and its total cost varies from 1*l.* to 2*l.* 10*s.*

An eka, or native carriage, for one horse, made at Patna, and intended to show the kind of single draft vehicle used by persons of rank in Hindoostan. The harness for the same will be found under the head of Manufactures from Animal Substances. Both carriage and harness have been contributed by Syud Meer Lupt Ali Khan of Patna.

Model of a carriage for ladies, of a bullock carriage, and of two carts—from Lahore.

Models of Mahratta carriages—from Rajah of Nagpore.

Model of state palankeen, made for the Rajah of Travancore, by Messrs. Simpson of Madras.

Country cart for bullocks, and basket complete, manufactured at Chicacole.

Model of a royal cart—Moulmein.

Wooden rath of Muchhunder Nath (a god); another, of Kumaree (a goddess); another, of Juggunnatte (a god)—from Nepaul.

Iron balance and weights: dharnee, bisoulce, seer, tin-paw, and ek paw—from Nepaul.

Water clocks for day and night—from Nepaul.

#### CLASS VI.—*Manufacturing Machines and Tools.*

Various spinning-wheels; models of spinning-wheels—from Bengal and Lahore.

Spinning-wheel for making pine-apple thread—from Singapore.

Reels for spinning pine-apple thread—from Singapore.

Model of a machine for twisting together silk threads, used in weaving—from Nagpore.

Model of a hand machine, for spinning cotton—from Nagpore.

Weaver's loom, and implements for manufacturing Dacca muslins.

Model of a weaver's loom; weaver's loom—from Bengal and Nagpore.

Hand-loom, on which the bugis sarongs are made, with cloth in the process of weaving—from Celebes.

Model of frame of hand-loom, as guide in setting up.

Hand-loom, complete with frame. Shows a much higher state of art than the Celebes loom, although the principle is similar—from Palembang, Sumatra.

Model of a loom for making gold and silver lace—from Moorshedabad, Bengal.

Weaving loom from Mysore and from Nepal.

Carpet loom, with a drawing, from Hoonsoor, in Mysore.

Samples of cotton, with description of process of manufacture—from Dacca.

Charka, for cleaning cotton, and cotton-press, from Broach.

Cotton-cleaning machine and charka, for separating seed—from Madura and Tinnivelly.

Rotatory cotton-cleaning machine—from Guntoor.

Mahratta cotton foot roller, and cotton mill—from Mysore.

Mill for extracting seed from cotton-pods—from Gwalior.

Model of a cotton gin—from Moulmein. Cotton cleaner, and various churkas for cleaning cotton—from Agra.

Cotton Jins, No. 1 to 4, Churkas, such as are used in the division of Agra, in the north-western provinces of Bengal.

No. 1 is the common native churka of the north-western provinces. It is of extremely rough workmanship, being made by a village carpenter at a low price within the reach of the peasant, and answers its purpose tolerably well; a practised person may clean 16 lbs. of cotton a day; but 8 lbs. is a full average for men and women working eleven hours.

No. 2 is a native churka, though not exactly in common use, it is more expensive than the first and costs about 3s.; but the great drawback is that the wooden roller soon wears out and is not easily replaced, as great accuracy is required that the spirals in the screws fit perfectly into each other. In effectiveness it is rather better than the common roller.

No. 3 is an attempt to remedy the inconvenience resulting from the rapid wear and tear of the wooden roller, by replacing it with a brass one.

No. 4 is another attempted improvement of great moment, in the addition of a roller with a small longitudinal bar, with the object of gently pressing the karpas or unseeded cotton into the rollers, and thus feeding the churka of itself. To be effectual this must revolve very slowly.

Cottage saw gin, made under the direction of the Commercial Association of Manchester, by Mr. Jamieson, at

Ashton-under-Lyne, and of which 200 were sent to India by the Court of Directors of the East India Company.

Clay model of female figure cleaning cotton. Clay model of old woman winding cotton.—Both from Mr. Blechyndyn; made at Moorshedabad.

Printing blocks, as used near Calcutta.

Implements used in manufacture of iron, viz.: two anvils, two sledge hammers, and a pair of pincers.

Utensils manufactured from Hazareebagh iron, with aforesaid tools. An anvil, hammer, small hammer, plough-share, and smith's tongs, the production of Mirzapore.

A cane for receiving water; strainer, baler, pan, and beater, native implements used in cleaning gold dust.

Iron tools for making silver filigree work—Cuttaek.

A drill, axe, chisel, saw, and file, as used by ivory carvers; also a pearl piercer—from Moorshedabad.

Grain and brick pounder; mortar and pestle for pounding grain; mill for pressing sugar cane; mill for grinding wheat—from Moorshedabad.

Model of grindstone and pestle and mortar—from Lahore.

Sugar cane mill and bruising machine—from Mysore.

A dalla, selinga, khorja, and niska, for cleaning rice—from Assam.

Curry-stone, for grinding articles of food, with grinder—from Ghazepore.

Oil-mill and house of the miller—from Gwalior. Maha Raja Rao Scindiah.

Model of an indigo factory and oil-mill—Jessore.

A potter's-wheel, and wheel for polishing jewels and sharpening knives—from Moorshedabad.

Hones set in sandal wood—from Bunsee in Boondie.

Grindstones of lac, with sand and corundum—from Coimbatore.

Carpenters' and masons' tools, carpenter's auger—from Lahore.

A still for distilling spirits—from Moorshedabad.

Axes, augurs, gouge, chisel, beetle-nut crackers, and cocoa-nut graters—from Singapore.

Nepaul tile, and wooden mould of the same.

Nepaul bricks and wooden mould, wooden pestle and mortar, bamboo—from Nepaul.

Wooden machine for preparing rice and spinning; wooden instrument, with which the seed is separated from cotton—from Nepaul.

Khose and jana bana, for spreading rice—from Nepaul.

Dundee, mhoosa, kokapoo, thoo, hatha, shirki, and kokathoo, ungoe kuthee, mool kuthee, and koenthee koo, forming a weaving-frame, with its materials—from Nepaul.

Wooden model of machine for grinding sugar-cane, from Nepaul; and another, used by Gorkhas.

Nepaul oilman's press, and one used by Gorkhas.

Wooden model of water-mill, for grinding corn, grain, &c., and stone of the mill, from Nepaul.

Wooden model of machine for preparing butter, from Nepaul.

Wooden rolling-pin, for making bread, and wooden spoons, used in warming milk, from Nepaul.

Bamboo milk-pot, for keeping milk, from Nepaul.

Instruments for working mines, from Nepaul.

Iron and wooden instruments, used by carpenters, from Nepaul.

Instruments used by goldsmiths, from Nepaul.

Tools, &c., used by leather-workers, from Nepaul.

Lechee, used by Phool plate-workers, from Nepaul.

Tools used by copper-pot makers, from Nepaul.

Tools used by blacksmiths, from Nepaul.

Tools used by bricklayers, from Nepaul.

Tools used by stone-cutters, from Nepaul.

Great difficulty has been experienced in identifying many of the articles sent from Nepaul, for the reasons stated by the Calcutta Committee—first, that the things were originally badly packed; and, secondly, that in coming down to Calcutta they were much injured by the rain, and lost their labels.

CLASS VII.—*Civil Engineering, Architectural, and Building Contrivances.*

Persian wheel for raising water, from Lahore.

Picottah model, for drawing water from a well, from Madras.

Model of iron bridge in Doottee; models of bridges on the Britawti River, Trisool Gunga River, Bishnomuti River, Bagmuti River, and of common bridges in Nepal.

Models of a tank, of soan dhara, and of a house, from Nepal.

Models of Godavery anicut, from Madras.

Breakwater adapted to Madras surf.

CLASS VIII.—*Naval Architecture, Military Engineering, Ordnance Arms and Accoutrements.*

(A.) *Models of Vessels employed by the Natives in navigating the Indian Ocean and Rivers.*

Models of vessels called Buglo, Naodee, Gungo, Koteo, and Muchoo, from Cutch.

Models of Cutch boats.—These models of boats are presented for exhibition by H. H. the Rao of Cutch, in which country, viz., at Maudavee, they were constructed, and have been sent to the Exhibition to show the peculiarities of Cutch ship and boat building.

Models of native craft.—Models of native craft frequenting Bombay, and the Malabar coast. These were made in the dockyard at Bombay, under the superintendence of Commodore S. Lushington, Commander-in-chief of the Indian Navy, and Captain Hawkins, I. N. The Arab batella, No. 8, is a private contribution from Captain Hawkins, which, after it has been exhibited, he wishes to be placed at the disposal of the Hon. the Court of Directors, for their Museum. It is considered perfect in every respect as a whole, and as to the detail; and the making of it has been superintended by an Arab from the Persian Gulf. It is made out of the wood of the "Cornwallis," which, after burning to the water's edge, was sunk here in deep water. For further particulars of this, and descriptions of the other models, see the following accounts:—

1 The Snake-boat of Cochin is a canoe of great length; they are used by the opulent natives and Europeans, as boats for the conveyance and despatch of persons on the numerous rivers and backwaters, particularly on that between Cochin, Allipay, and Quilon, which is about 80 miles southward, and on that which runs to Palipact and Triehoor, the former place being about 20, and the latter about 60 miles to the northward. These boats are from 30 to 60 feet in length, without any regard to breadth or depth, as they are worked from the solid tree; the broadest do not exceed three feet. Those of the Raja and officers of state are very handsomely fitted up, and carved in the most fantastical manner; they are made very neat, and even splendid, with painting, gilding, &c. The largest boats are sculled by about 20 men, double banked, and when pressed, their velocity is surprising, as much as a mile in five minutes. These boats are peculiarly adapted to the rivers, for it frequently occurs, that in dry seasons, there are sand banks perfectly dry, nearly 100 yards in breadth, over which they must be drawn, by the strength of the few men who are in them; the smaller size having only six rowers and a cockswain.

Those natives who can afford the expense, have the cabin neatly fitted up with Venetian blinds on the sides, but generally the cuscus or grass mat is substituted.

2 The Catamarans of Madras are formed of three logs of timber, their length is from 20 to 25 feet, and breadth  $2\frac{1}{2}$  to  $3\frac{1}{2}$  feet, secured together with three spreaders and cross lashings; the centre log being much the largest, with a curved surface at the fore end, which tends and finishes upwards to a point. The side logs are similar in form, but smaller, having their sides straight, and fitted to the centre log.

These well-known floats are generally navigated by two

men, but sometimes by one only, with the greatest skill and dexterity, as they think nothing of passing through the surf at Madras, and at other parts of the coast, while boats of the country could not live on the waves. At sea they are propelled through the water to a ship on the coast, when boats of the best construction and form would swamp.

3 The yacht "Wave," or fishing-boat of Bombay.—This boat is the property of an officer of the Indian Navy,\* her model was taken from a fishing-boat of Bombay. The keel is curved, and being at the fore end 2 feet below the level of the keel amidships, it serves as a gripe or lee-board, and tends to make the boat weathery. She has comparatively a flat floor, a hollow entrance, and a sharp flat run; her length over all 46 feet. Entrance breadth, 12 feet, and depth amidships, 3 feet 8 inches. Her main-mast is 36 feet in length, main-yard, 65 feet, mizen-mast, 22 feet, and mizen-yard, 40 feet. Sails lateen, made of drill, sewn in narrow cloths.

She was built as a pleasure yacht, but more particularly for the regattas, for which Bombay is famous, and when ballasted, has won many prizes. No boat of European form and construction has, as yet, been found to compete with her in point of sailing, in moderate weather.

4 The Jaugar, or Ferry-boat of Cochin, is formed by placing a floor of boards across two boats or canoes, from 10 to 12 feet fore and aft, and about 16 feet long. When these boats are thus formed into a raft, cattle and burthen-some articles are conveyed in them across the rivers, as also troops, with all their followers, horses, bullocks, &c. The boats or canoes are cut out of a solid log of timber, and are from 8 to 20 feet in length, 18 inches to 2 feet in breadth, and from 12 to 18 inches in depth.

When employed singly, the canoes are managed with much dexterity by the natives, with a scull or paddle, on the backwater of Cochin; and at the mouths of the creeks they are employed in great numbers in fishing.

The larger sort of boats are used for the conveyance of rice and merchandize on the numerous small rivers which flow into the backwater, extending 150 miles parallel to the sea coast.

5 The Cotton-boat of Bombay.—This description of boat belongs entirely to the port of Bombay, and they are so called on account of their being invariably employed in conveying cotton from the shore to the ships bound for China and Great Britain, loading with that article. These are the only boats made use of in loading and unloading the numerous kind of outward and inward cargoes of ships visiting the port. They are from 25 to 35 feet in length, 10 to 13 feet in breadth, and  $3\frac{1}{2}$  to 4 feet in depth. They are very rudely but strongly built, and the largest of them will carry 15 tons of dead weight. They are employed in bringing the produce of the Island of Salsette, such as grain, grass, vegetables, &c., to Bombay, also for the conveyance of troops with their baggage, to and from Panwell.

The inside of the boat is lined with bamboo matting to protect the cargo from bilge water. They are generally navigated by a crew of six men and a tindal, principally Mahommedans, who live in the boat.

On one side of the mast is a fire-place, and on the opposite a cask or tank, containing fresh water. The bottom is annually, or oftener, paid over with a mixture of chunam, or lime, and vegetable oil, which hardens, and is a good protection against worms. They have one mast which rakes forward, and a yard of the same length as the boat.

The cost of one of the best of them complete is about 700 rupees. They are mostly hired by the day, at a rate varying from two to five rupees, according to their size and season of the year.

6 The Dingee, or Bum-boat of Bombay, is a small boat, from 12 to 20 feet in length, 5 to 7 feet in breadth, and 18 inches to 2 feet in depth; with a raking mast, and a yard the same length as the boat; they are navigated by three

\* Mr. J. A. Keys, Assistant Indian Naval Storekeeper.

to four men, who very frequently are joint owners of the boat.

The dingees sail very well, and are employed in carrying persons to and from vessels in the harbour: they also carry people desirous of visiting the Islands of Elephanta, Caranjah, and others in the harbour of Bombay. It is generally the practice with captains and commanders of ships to hire one by the month, at the rate of 40 to 50 rupees. When so employed, they take off meat and provisions in the morning from the shore for the day's consumption, after which they are ever ready to convey officers to and from the ship, carry messages and notes, and any other service required of them.

The hiring of these boats is a great advantage, as it not only saves the ship's boats from being knocked about, but keeps the European seamen from exposure to the sun, which would injure their health, were the ship's boats so employed.

7 The Point de Galle Canoe is a boat formed from a single stem of doopwood, or pine-varnish tree. They are from 18 to 30 feet in length, from 18 inches to 2½ feet in breadth, and from 2 to 3 feet deep, exclusive of the wash-board, which is from 10 to 18 inches broad, and sewed to the gunwale with coir yarns, with loose coir padding on the joints.

These boats are fitted with a balance-log at the bamboo outrigger, having mast, yards, and sail secured together. Vessels passing the southern coasts of Ceylon are generally boarded by these boats even at the distance of 20 to 25 miles from shore.

They will sail at the rate of 10 miles an hour in strong winds, which are generally prevalent there, and with a crew of five men will carry a cargo of vegetables, which are great luxuries to the crew and passengers after a long voyage from England to Bombay and Bengal.

8 The Batelles of Bombay and Surat. The batelles belong principally to the merchants of Bombay and Surat, and are decidedly the best built and better found in fittings and stores than any other description of boats of Western India. They are built entirely of teak-wood, well planked, and fastened with iron nails and bolts; they have a great rise of sheer forward, and a regular stem, with mados abaft; some are fitted with a cabin under the poop, but the majority of them carry bamboo decks over beams fitted for the purpose.

They are from 35 to 50 feet in length, 15 to 20 in breadth, and 5 to 7 feet in depth, and from 25 to 100 tons burthen. They are lateen rigged, having a main and mizen mast, both raking forward, and a boom forward, on which a jib is set: the main-yard is a little longer than the extreme length of the boat. They invariably have a break in the topsides from the fore part of the poop to the luff of bow, nearly level with the beams, for the facility of taking in and out heavy cargo. At sea this break is stopped up by bamboo mats inside, and outside with soft mud or puddle between. This excludes water, and is as water-tight as any other part of the hull. It is a remarkable fact that one never hears of any damage done to the cargo from this part, although when the boat is fully loaded the break is about 1 foot or 18 inches above water. These boats import cotton from Surat, Broach, Cambay, and other cotton-growing districts to Bombay, and teak timber from the northern forests, extensively used in ship-building and other purposes at Bombay.

9 The Arab Batelle. The batelles were the boats principally used by Joasme pirates of the Persian Gulf, who were a terror to the native mariners till exterminated by the united efforts of the King's ships and the Honourable Company's vessels of war.

The batelles have a very sharp and hollow floor, a very clean run, and a perfect wedge-like entrance, which offers little or no resistance to the water. They are noted for their fast sailing and weathery qualities, so much so that it was found very difficult by the vessels of the Royal and the Honourable Company's navy to capture them, even when the pirates were supposed to be on the point of surrendering, as they frequently made off in gallant style

when within gun-shot of the ship, and were chased and pursued in vain. The Arabs assert that no vessel could sail so close to the wind as the batelle, and there seems good ground for the assertion.

The mode of steering the batelle is very singular, as may be seen in the model. The rudder projects several feet below the peel of the stern-post; to the afterpart of the rudder is fixed the tiller, which has a curve pointing upwards; the ropes are led inboard by means of an outrigger at the side, by which the helmsman steers the batelle. They require very little head, as, indeed, the rudder is confined to a certain point by spreaders nailed on the stern-posts.

The batelles are lateen rigged, and have three suits of sails made of Bahrein canvas. In calms they are propelled by sweeps. The largest size batelle is 150 tons, and now only used by the Arab chiefs of the Persian Gulf on state occasions and visits of ceremony. This model is a private contribution from Capt. Hawkins, I.N., and is finally intended as a present to the Honourable the Court of Directors for their Museum.

10 The Arab Dow. This was another description of vessel used by the pirates of the Persian Gulf. The form of the dow is calculated for swift sailing, as they have a sharp floor and clean entrance. There are very few of these boats now in existence, as from their size and construction they are ill-adapted for the purposes of trade, and since there are no pirates there now, the dow will shortly become extinct. The peculiarity of the dow consisted in a long projecting gallery at the stern. The pirates used to impel the boats with sweeps stern foremost, and board from this gallery. The largest dow is about 200 tons. The bottom is paid over with a mixture of lime and boiled tallow, which hardens by exposure, and serves to keep it clean and free from the attacks of barnacles and other marine animals.

11 Cutch Dingee. These vessels are from 30 to 50 feet in length, 15 to 25 feet in width, and 7 to 10 feet deep, and from 20 to 100 tons burthen. They have a good rise of floor, and a fine entrance and run, calculated for fast sailing: some of them are decked wholly, others only abaft the mizen mast and a small part forward, the rest being left open for the stowage of cargo, which is frequently stowed considerably above the level of the gunwale, in which case a barricading of bamboo and coarse mats is fixed as a temporary protection: when not fully loaded, the materials are laid over slight wood framing between the beams which serve the purpose of a deck.

These vessels are tolerably well built with a mixture of jungle and teak wood, and fastened with nails, which go through, and are turned on the inside of the timber. The stern is very high, with double poop; the sides are perforated with ports, and ornamented with rough carving, and often painted a variety of colours. They belong principally to Cutch, Mandavee, Poar Bunder, and other sea-ports under the dominions of the Row of Cutch, and are navigated by a crew of 12 to 20 men, and a tindal. Their import cargo to Bombay is ghee (clarified butter, used extensively by the natives of India), salt fish, mustard, and grain; and the export cargo is piece goods, cutlery, metals and rice. Some of the largest go to Muscat and other ports in the Persian Gulf: they navigate the sea only in fine weather, and are invariably laid up in the south-west monsoon from June to the end of August. They are very frequently employed by the government for the conveyance of troops and stores to and from Kurrachee and other ports in the Presidency.

12 Cutch Cotiyah. These boats belong to the ports of Cutch, Mandavee, Poar Bunder, and some to Kurrachee, in the newly-acquired territory of Scinde, and trade between Bombay and those ports. They are very well built, with a square tuck, and many of them have a regular built stern, with ports, and handsomely carved. Some of them have a deck fore and aft, but more commonly they have frame-work between the beams, to ship and unship, for the facility of stowage, and a bamboo deck. They are from 30 to 50 feet in length, 12 to 23



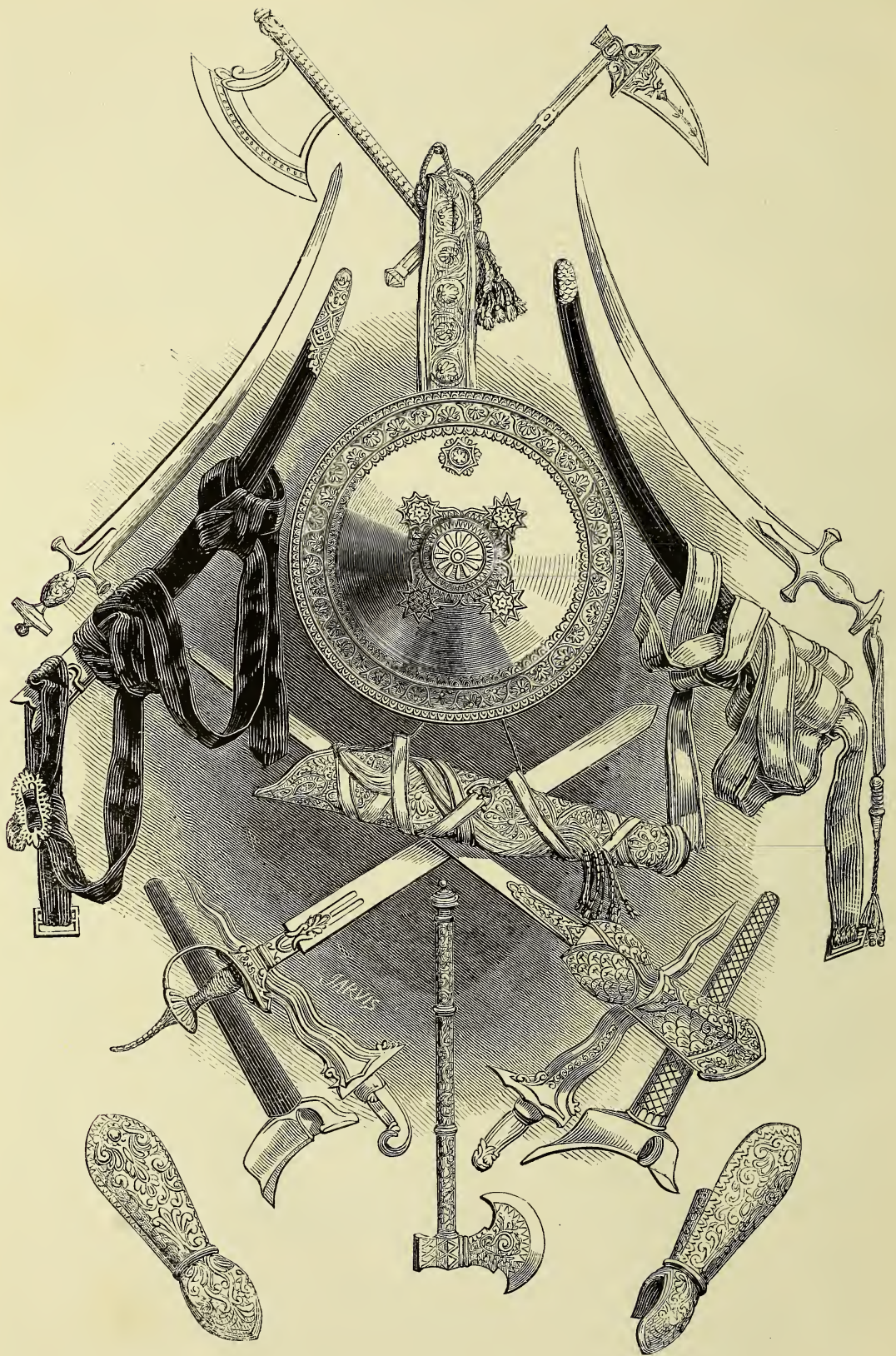

feet in breadth, and 7 to 10 feet deep. They export salt-fish, grain, and other produce of the ports to which they belong. They are navigated by a crew of from 15 to 20 men and a tinda. They are lateen rigged, with a main and mizen sail, both masts raking forward, to keep the ponderous yards clear of the mast in lowering and hoisting.

These boats frequently take up troops and government stores to and from Kurrachee and other neighbouring ports to the Presidency.

13 The Ceylon Doni is a huge vessel of the ark-like form, about 70 feet long, 20 feet broad, and 12 feet deep, with a flat bottom or keel part, which at the broadest place is 5 to 7 feet, and tapers at the fore and after ends to about 10 inches. The fore and after bodies are nearly similar in form from a-midships; their light draught of water is about 4 feet, and when loaded about 9 feet. These rude, unshapely vessels trade from Madras and the coast to the island of Ceylon, and many of them to the Gulf of Mannar, as the water is shoal between Ceylon and the southern part of the continent. They have only one mast with a lug-sail, and are navigated from land to land and coastwise in fine weather only.

Arab bugalow, and pattamar of Bombay, from Bombay. —No description has been sent of this kind of vessel.

Kurrachee bugalow.—This is the only model supplied from Sindh.

The boats of the Indus and other crafts peculiar to Kurrachee were ordered; but the people who were employed to make them did not fulfil their engagements.

Model of a pleasure-boat of a Sikh chief, from Lahore.

Massulah boat, with oars, and a small cutter, from Madras.

Model of a boat and of an oar, from Nepaul.

Models of Lanum pirate prahus; the first class carries a crew of 100 men, and the second class a crew of about 60 men; from Mindanao.

Model of Padewakhan, or Bugis trading prahu. The Bugis trade and the Trempang fishery are carried on in these vessels from Singapore.

Models of Sampan boats, peculiar to Singapore; three classes; first class very swift: from Singapore.

Tambangan or Sourabay passage boats.

Model of a large cargo boat, such as is used upon the Ganges, &c.

Model of a dinghy or small boat, ditto.

Model of a Burmese coasting vessel.

#### (B.) *Arms, Ordnance, and Accoutrements.*

Accoutrements:—Caps of rhinoceros hide, from the Rao of Cutch.

Shako topee, used by the lighter battalions, and black turban, used by Gorkha battalion; from Nepaul.

Silver moons, used by various battalions, from Nepaul.

Silver moon of the Rifle Company, and silver chain used by Nepaul non-commissioned officers, from Nepaul.

Breast-plate, cloth jacket, cotton jacket, broad-cloth pantaloons, and cotton-cloth pantaloons, used by Gorkha battalion, from Nepaul.

Bengra cloth bag, for carrying sepoy's provisions, from Nepaul.

Nepaul captain's coat, worked with golden thread, from Rajpootanah.

Cloth pouch, belt, &c., studded with brass nails, from Rajah of Kotah.

Pouch, belt, powder-flasks, &c., from Jeypore.

Powder-flasks, and powder and shot belts, from Mundote.

Powder-flask, and girdle and pouches, used by Gorkhas, from Nepaul.

Matchlocks, pistols, &c.:—Matchlock, with pouch-belt, from Rajah of Boondie.

Two amber matchlocks, with powder-flasks, &c., from the Rajah of Jeypore.

Three matchlocks, manufactured in the city of Patna, contributed by Baboo Koomar and Dyal Sing of Patna.

Matchlock manufactured at Bejnour, from Nugeena.

Matchlock manufactured at Bejnour, from Dhampoor in Rohilkund.

Two matchlocks, with apparatus complete, from Dholepore in Rajpootanah.

Matchlock gun, matchlock rifle and rest, two rifles, and three rifle matchlocks, from H. H. Goolab Sing, Lahore, Mundote.

Matchlock, from the Rao of Cutch.

Matchlock, with gold mountings, and two small gold chains, from Gwalior, from Maha Rajah Rao Scindiah.

Gun, complete, in a case, with implements, made after European design in the states of Nepaul.

Single barrel percussion gun; matchlock, gold mounted; pistol; and spare pistol, flint lock, from H. H. Meer Ali Moorad, Khyrpoor. These are private contributions from H. H. Meer Ali Moorad, which arrived here without description, and so late that there was but just time to re-pack them, and send them off on the following day. It is to be presumed that they are native manufacture, at least the matchlocks.—*Bombay Report.*

Pistol, from Lahore, and Rajah Goolab Sing.

Pair of pistols, manufactured at Agra. The manufacturers of Agra turn out pretty good weapons at comparatively low prices.

Swords, &c.:—Sword, with enamelled hilt; sword, with pistol and dagger affixed; sword, from Rajah of Kotah.

Three swords, from iron of Chota Nagpore; and two ancient swords, from Rajah of Bettiah, Moorshedabad.

Sword, from the Rao of Cutch.

Sword, from Malwa.

Sword, from Nawab of Rampore, Rohilkund.

Various swords, from Lahore.

A sword as used 40 years ago; a sword as used now; an old Mahratta sword, from Gwalior, from the Maha Rajah.

Sword scabbards; swords and daws.

Battle-axe, from Boondie.

Battle-axes, from Lahore.

Battle-axe, manufactured from indigenous substances in the dominions of the Rajah of Boondie, Rajpootanah states.

A kind of sword, khora; a short national sword, khookree, from Nepaul.

Swords and sheaths, from Acheen, Sumatra.

Two swords with gilt handles, from Rajpootanah.

Two hilts of swords gilt, from Tonk in Rajpootanah.

Serohi sword blade of white steel, inlaid with gold; Serohi sword blade of dark steel, hilt richly inlaid with gold; Serohi kuttar or dagger, dark steel, inlaid with gold; Bheel bows of bamboo; quivers of bheel arrows, manufactured at Serohi in Rajpootanah states.

A helmet and a complete suit of steel armour, inlaid with gold, from Dholepore in Rajpootanah.

Two daggers, with enamelled shields, from Scinde.

Swords, mounted with gold and belts, from Khyrpoor.

These blades are probably very scarce and dear. They are made of the fine ringed steel so esteemed in Sindh and the countries to the northward of it: they are termed Khorassan blades. They came among the collection from H. H. Meer Ali Moorad.

Kuttaroo or dagger; tabber or battle-axe; tabber of another kind; sword, spear, &c., from the Rao of Cutch.

Klewang, or sword, from Batan.

Sword of native iron by people of Kota, from Borneo.

Two daggers, manufactured entirely of native materials, from Rajah of Boondie.

Shields:—Shield of deer-skin, transparent, with enamelled bosses; and shield with gold bosses, each boss concealing a pistol, from Rajah of Kotah.

Shield, manufactured in the Rajpootana states.

Shield, from Lahore.

Shield, rhinoceros hide, from the Rao of Cutch. These are manufactured in Cutch for the neighbouring countries. They are made out of the rhinoceros hide brought from the eastern coast of Africa.

Rhinoceros shield, from Nepaul.

Spears, bows, and arrows:—Mahratta spear, from Gwalior.



Arrows, spear, and bows, from Lahore.

Bareilly painted bow, arrows, and quivers, from Lahore. A quiver and numerous arrows, from Gwalior.

Bow; quiver with arrows; guard against bow-string, worn by the archers in left hand; small bow; kind of bow with iron chain instead of a string; small spear—from Nepal.

Bows and quivers, as used in the province of Assam.

Ranching, or stiletto-dagger, from Acheen, Sumatra.

Sling, bow, and a bag of clay balls, from Nepal.

Bow-strings of fibres, Low Country, with a bow and four arrows, from Calicut.

Two war rings, from Rajah of Pattiala.

Pair of wrestlers, as used in the North-west Provinces.

Cutting instruments of war (Cutch). These are manufactured in Cutch.

Chain-armor, head-cover, sword, dagger, spear (point and but only), embroidered sword-belt, belt, shield, bag with pouches, and a matchlock, from Rajpootanah.

Fowling-piece with flint-lock, the barrel engraved with flowers; another fowling-piece; bullet-moulds for the above; sword inlaid with pearls, one side steel, the other iron; sword of steel, with two blades in one, forming two swords; dagger with two blades, in appearance one, but when separated forms two; knife with three blades, also in appearance one; chooree.—Contributions of H. H. the Maharajah of Ullwar.

Chain armour, with head-cover, from Rajpootanah.

Set of steel armour inlaid with gold, from Dholepore in Rajpootanah.

Helmet and iron armlets, from Gwalior.

Burmese shield, daggers, sword, and large knife, or chopper.

Sword and three daggers; two quivers, each containing sixty arrows; kaunda, a sword with gold mountings; matchlock, with gold mounting; bags for the matchlock; belt and pouches of silver for the matchlock.—Contributed by H. H. Maharajah of Jodhpore.

The following articles are used by Indian athletes:—Bamboo bow, with iron chain in place of string; wooden clubs of Sissoo wood: two-handed sword, made at Saugor, Central India; shields for practising sword-play; foils, or sham swords, from Marwar.

Kuttar, or dagger, jewelled. A dagger, containing another within it, and one which opens into five blades, from the Rajah of Pattiala.

Suit of armour; two pieces of horse armour; suit of armour, nine pieces; two locks; blunderbuss (Sikh); cannon (model); double cannon (model); mortar (model); howitzer; camel-gun and saddle, from Lahore.

Hill-gun complete, from M. H. R. Goolab Sing.

Ordnance and models:—Two 3-pounder brass ornamented guns, with carriage complete, from Kurnool.

Two brass guns, lelah, or swivel guns, as used by Malay prahus. Forwarded from Singapore.

Models of two brass guns and carriages, from Mysore.

Models of two oriental brass guns.

Various models of the artillery of the Indian army, from the three Presidencies. From the military stores, East India House.

“Tent, manufactured at the Jubulpore School of Industry. The whole of the materials used in constructing this tent have been manufactured, and the tent itself has been built by Thugs, and the sons of Thugs, who have learned their several trades in the Jubulpore Government Institution. The fact of its being throughout the work of reclaimed murderers, who only a few years ago subsisted on their fellow-men, and of their progeny, who, but for the measures of a benevolent government, would assuredly have followed the same trade, will, it is hoped, obtain for it an interest which neither the materials or construction could otherwise have done.”

CLASS IX.—*Agricultural and Horticultural Machines and Implements.*

Wooden models of two kinds of ploughs and carts, from Bengal.

Agricultural implements used in Tenasserim Provinces:—Plough, harrow, hoe, spade, sickle, rake, and bamboo stick covered at one end.

Agricultural implements used in Kemaon, North-west Provinces:—Plough, yoke, whip, mattock, hoe, rake, muzzle, shovel, reaping-hook, chopper, axe, and cotton-cleaver.

Agricultural implements used in Hooghly, Lower Bengal:—Plough, yoke, harrow, ladder used as a harrow, weeding instrument, plank on which paddy is beaten out, tripod stand for the same, and broom for sweeping the grain.

Model of Mahratta plough.

Models of a plough and a harrow, from Lahore.

Model of a drill-plough, from Broach.

Ploughs of various descriptions, from Nepal.

Iron hoes, grass-scraper, small hoe, pickaxe, and axe to cut wood, from Nepal.

Models of a plough, a harrow, and scarifier, to be drawn by buffaloes, from Malacca. These are used by the natives of Malacca. The scarifier is drawn by one or two buffaloes, and employed in cleaning from weeds and lallang the ground that has already been broken up by the plough.

Model of a chunghol, or large hoe; model of a sort of scythe; of a paddy reaper, and of a ratan cutter; from Malacca. The chungol is in very general use among the labourers of the Straits Settlements, and the scythe is used in cleaning the lallang, or coarse grass and brushwood from lands that have been allowed to lie fallow, preparatory to re-cultivation.—All forwarded by the Singapore Committee.

Model of a rice-husking machine; of a husbandman with agricultural implements: of two harrows and a plough; and of a harrow to be drawn by buffaloes, from Moulmein.

Models of agricultural implements, carts, mills, &c. This is a collection from Belgaum. They are a private contribution from H. Reeves, Esq., collector of Belgaum, who has accompanied them by the following description:—

*Description of Models of Farm Implements, &c., used in the Southern Mahratta Country.*

1 Bazaar cart, or gharree. This vehicle has been much improved since the European camps have been established. They are used for the transport of goods from station to station, and for carrying timber. Generally drawn by two bullocks.

2 Cotton press. There is no description of the cotton press.

3 Oil mill or ghannah, used for the purpose of expressing oil from different kinds of seeds. This machine is drawn by one, two, or three bullocks, according to its size. The most common size is for two, and a pair of buffaloes are the animals generally used. The block of wood excavated is first set into the ground, and firmly fixed; the pole or friction shaft is then introduced, and the portion with the small chain on it is then adjusted by placing the top of the friction pole into a small hole made for the purpose. The seed for oil is then placed in the hollow of the block, and when the oil begins to ooze from it, it is dipped or mopped out by a small bundle of rags, and the oil squeezed from this into a vessel. Each portion of this machine is numbered so as to correspond with the block or principal portion.

4 Wuddars cart or gharree. These are frequently made without one particle of iron in their construction, and drawn by two buffaloes. They are used by a peculiar race of people, called Wuddars, who never live in houses, but travel from village to village, and find employment in supplying the inhabitants with stone, timber, and other materials for building, which they bring on these carts.

5 Thrashing floor or kullie. This model does not rightly represent the kullie, as it is simply a circle cleared on the bare soil, with a pole set up in the centre to fasten the bullocks to, as many bullocks as the ryut has; often his cows and milch buffaloes are fastened to it and used.

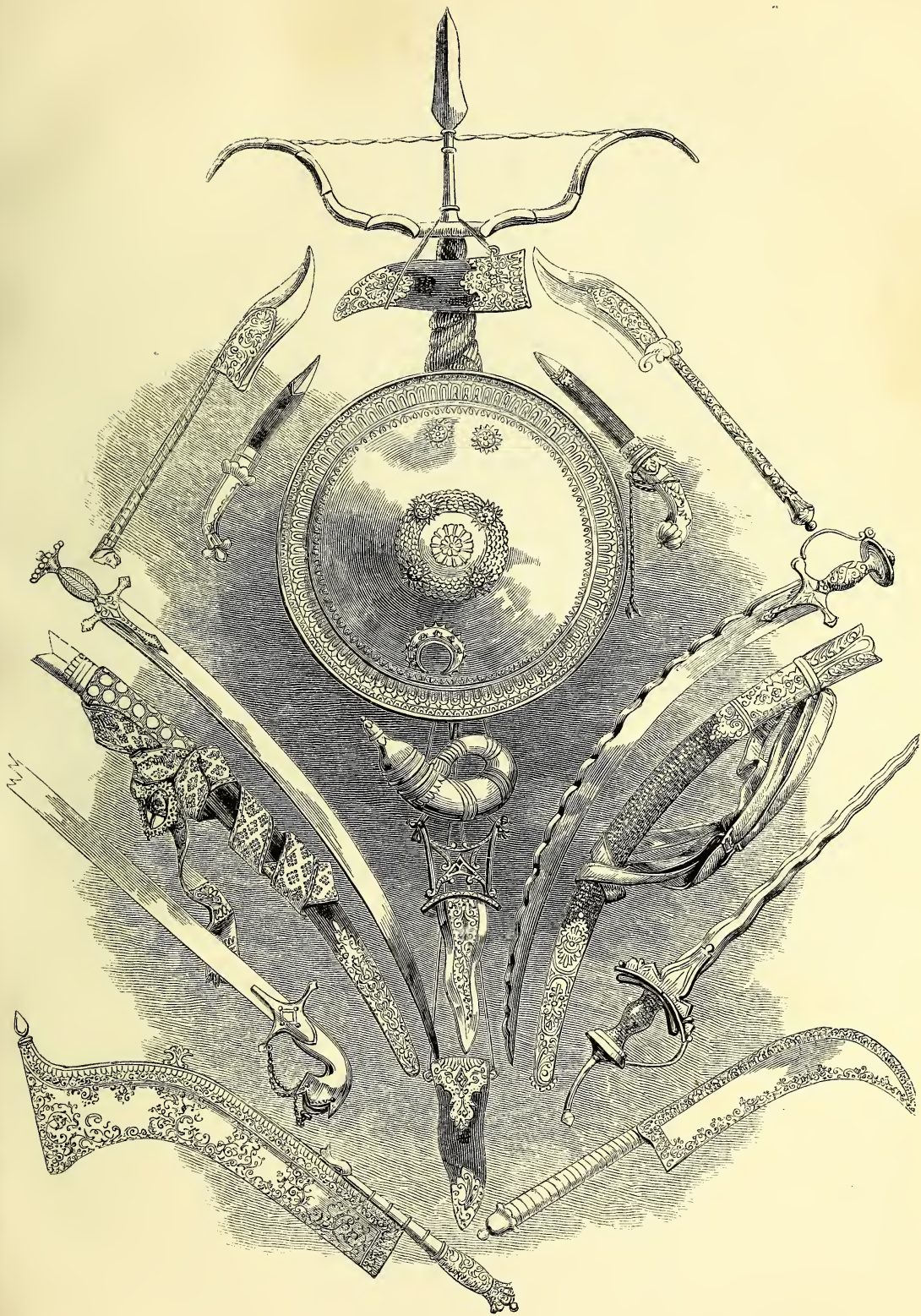





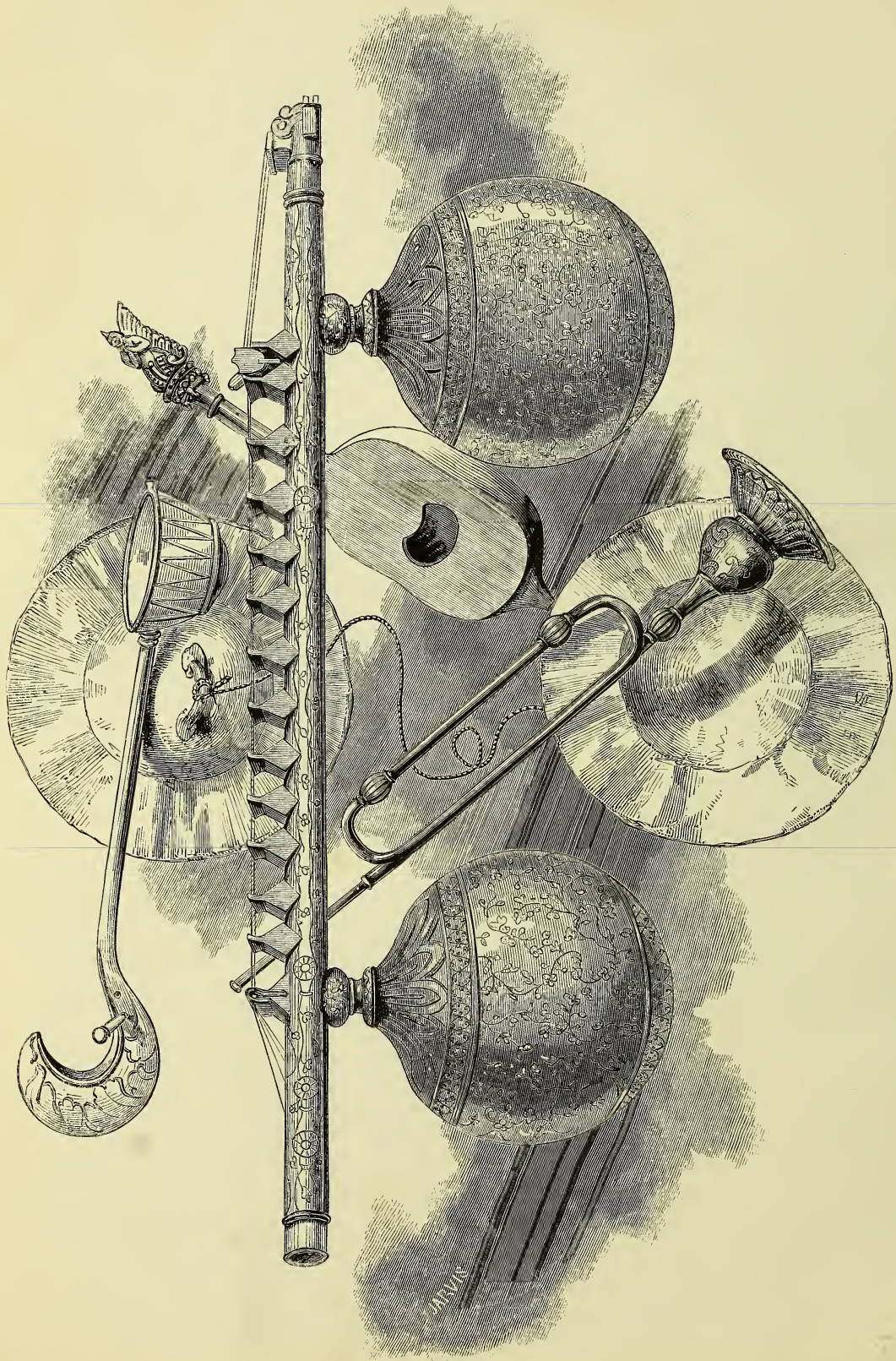



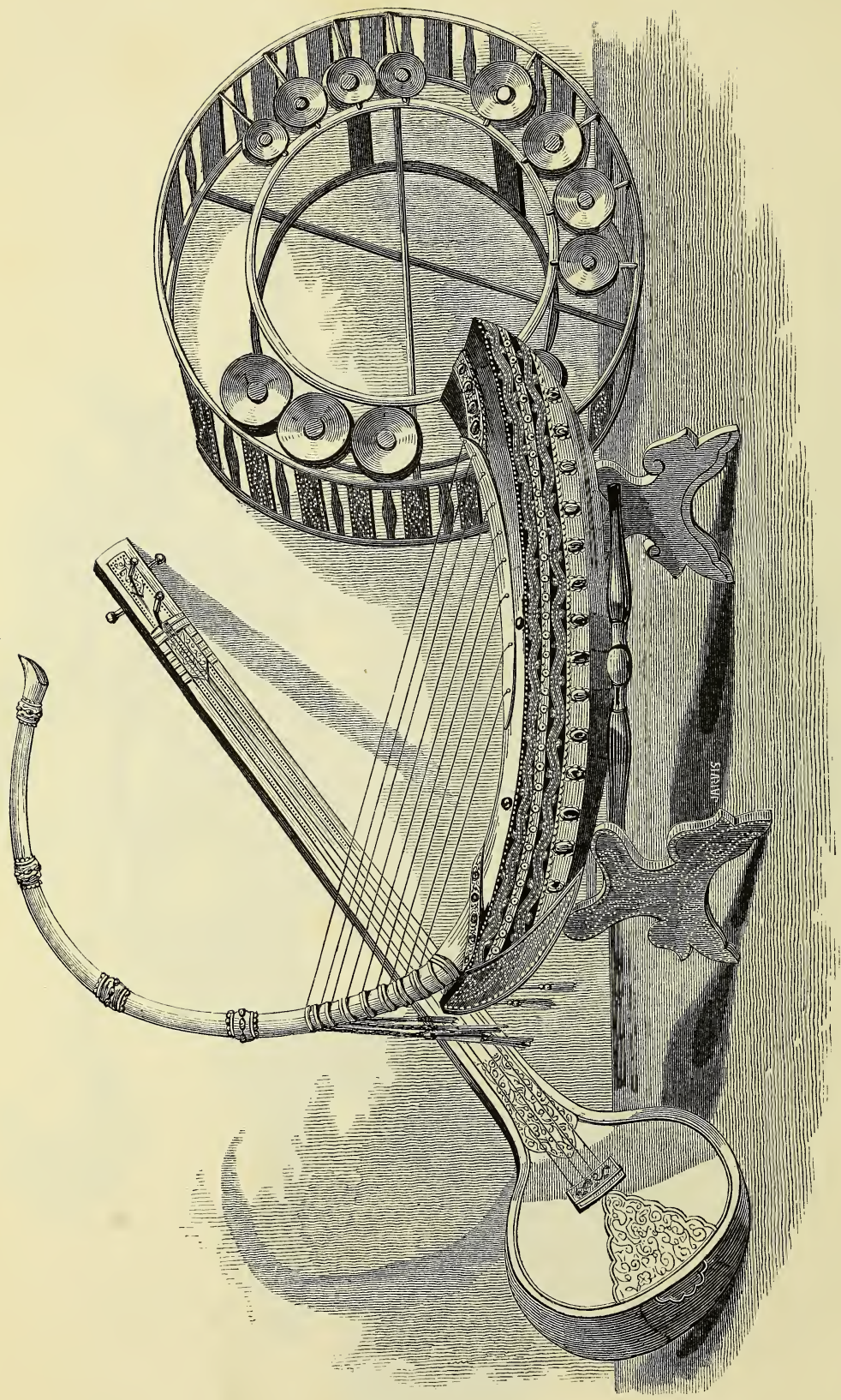

NATIVE MUSICAL INSTRUMENTS. INDIA.





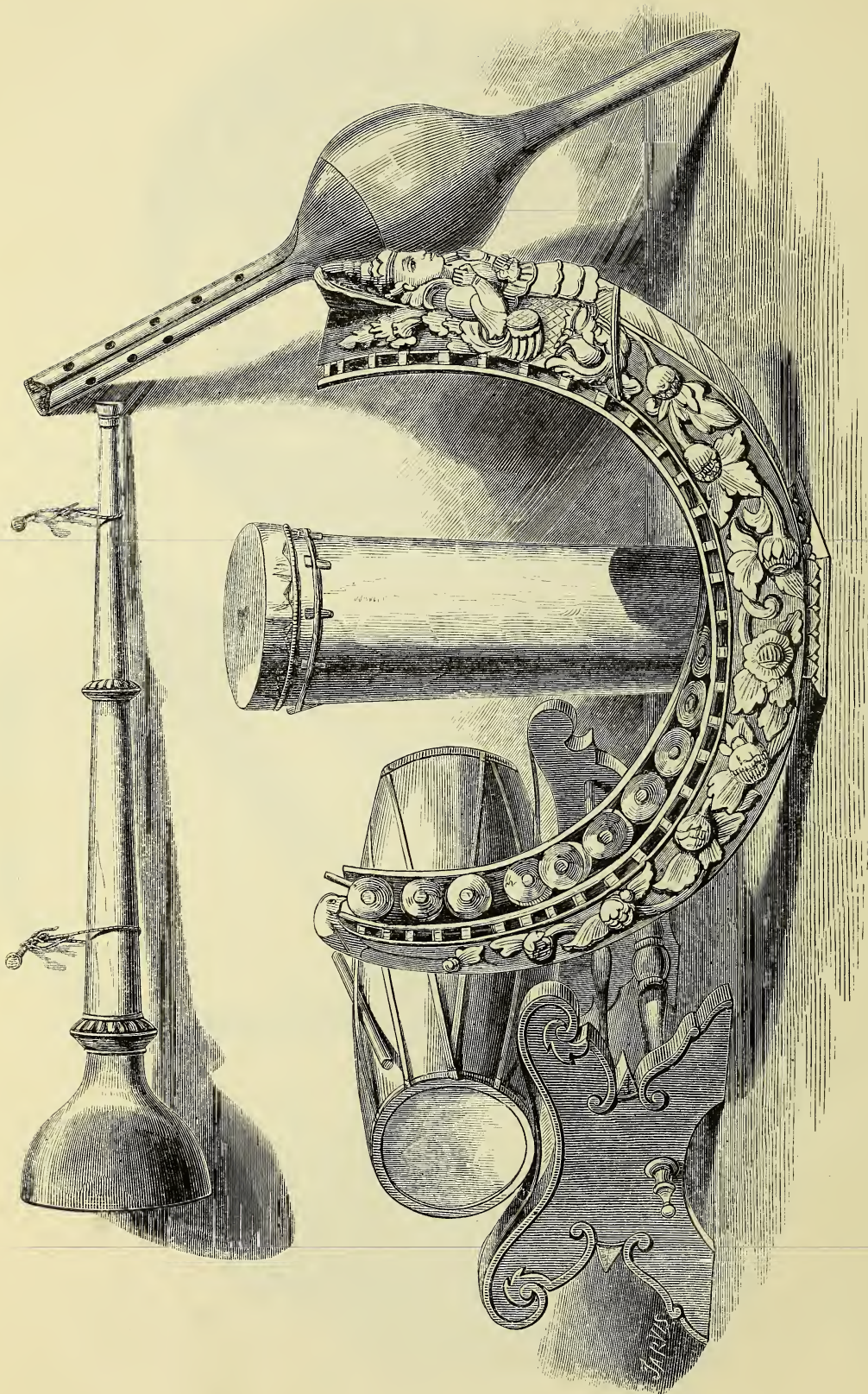

NATIVE MUSICAL INSTRUMENTS. INDIA.

The Mungora and Akree are used in moving up the grain stalks whilst the bullocks are moving round.

6 Farm cart or gharree, or coontee for six or eight bullocks. Farm cart or gharree. Six, eight, ten, and sometimes as many as twelve bullocks are harnessed to these carts; they are used for all farm purposes. The small bundle of things marked with its number will fit it up for carrying grass, or hay, or grain in sheaf. It is looked on by the natives as a perfect fortune to have one of these in the family, and they are handed down from father to son as such.

7 Pair of bullocks. There is no description of the kind of bullocks.

8 The plough, kuntee, or nagur. This implement is but seldom used in the black soil; and when used is really of such little service to the land, that the time is nearly thrown away. It is drawn by two bullocks, the man generally keeping his foot on the plough to keep it in the soil.

9 Coontee or ballisall. Indian harrow or ballisall. This is similar in construction to the coontee, but the iron blade is made narrower and lighter; its use is to follow the coorgee in planting; drawn by two bullocks, it levels the soil, covers in the seed, and, if properly handled, does its work perfectly.

10. Coorgee, or drill plough, for planting rice. This implement is drawn by two bullocks, and the seed is placed by the hand into the cup at the top, when it passes through the bamboo pipes into the ground.

11 Coorgee for planting wheat, &c. This implement is drawn by two bullocks, and fed with the grain in the same manner as the rice coorgee. The bamboo pipe attached is used in the planting of cotton or dhall, when a woman or boy, taking it in their hands, walks after the coorgee to which it is fastened by a rope, and passes the seed through it into the earth. There is often two and three to each coorgee.

12 Cart man.

13 Hoot, or rice weeder. This implement is drawn by two bullocks, and used for stirring the soil among the rice plants, when their tops are just above water; each tooth passing between the rows of plants, it tears out the weeds.

14 Coorgee for cotton. Coorgee, used for planting cotton, where the land is grassy or soil heavy. Its only difference from the other being its strength, and having the teeth further asunder.

15 Yellie coontee. Indian weeding harrow, for jowaree, grain, and other dry grains. These are drawn in pairs by two bullocks, one man to each coontee, which he guides by holding the handle of the implement in one hand, and in the other a small stick with a fork at the end, which he presses down on the coontee. The stalks of the grain pass through the opening between the two irons.

16 Yellie coontee, or weeding harrow, for cotton. This is similar to the one used for grain, but is passed only between the rows.

17 Halka for grass. Used in the rice-fields, prior to planting, to remove weeds and grass that may be lying loose on the soil; drawn by bullocks.

18 Indian harrow, coontee or goontee. This is a very useful implement, and were a good English plough used before it, the soil would be well prepared. They are of different sizes, with two, four, and sometimes six bullocks, the drawer standing on the implement.

19 Byle phullee. This is drawn over the land, in dry weather, after the soil has been ploughed or coonted, to level and break down the inequalities in rice fields, and is generally drawn by two bullocks. It is simply a plank to which a rope is fastened by two iron rings, a man holding it nearly perpendicular, so as to catch the high portion of soil, and draw it to the hollows.

20 Oil-mill man.

21 Haut fulla. The same as the foregoing (No. 119), but used by manual labour, one man drawing it along, whilst it is held perpendicular by a second.

22 Heudora, or clod-breaker. This is drawn over the

fields to break the clods, a boy or man generally sitting or standing on it to add to its weight.

Goota. This is used after the hoot (No. 13), and is intended to bend the young plants down into the water. It is drawn by bullocks at a good sharp pace across the rows of plants, and which is said to make them grow stronger.

23 Rake for kulla. No description of the rake for kulla.

24 Karta. There is no description of karta.

25 Kudlie or pickaxe. Those in use in this part of the country are of very rough make, but do not differ in name or use.

26 Pau Kudlie or hoe, otherwise called salkee.

27 Saul and Rhaut. Saul: this is used to lay out the yarn after being spun, and from which it is formed into hanks by folding it over the elbows.

Rhaut or spinning wheel. In this process the woman sits down, with one leg extended as the figure represents, the fore-finger of her right hand is placed in the small hole in the handle of the rhaut which she twirls round, and with her left attaches the bit of cotton to the spindle, drawing the hand back as the thread spins out.

28 Coorpa or grain hook. There is no description of the coorpa.

29 Coorpa or grass hook for cutting grass.

30 Coorpa for weeding. These three all bear the name coorpa, and only differ according to the fancy of the owner; they are of the most miserable manufacture, and generally worth a few pice.

31 Akie. There is no description of akie.

33 Coorpa or cleaning knife. Used in the removal of the soil from the counties whilst at work; a very simple and paltry instrument. Knives, however, being scarce among the natives, this instrument is often made very sharp, and kept for the purpose of cutting rope or other things as required.

Models of Agricultural Implements and Mills used by the Natives of Sattara:—

1 A kind of harrow, used in planting sugar-cane plants, and keeping in order the fields of the same.

2 Chowphunnee cooree, used in sowing small grain, such as "warree" (a kind of rice), &c.

3 Plough, used in ploughing ground.

4 Trephunnee used in sowing large grain, such as gram, &c., like No. 2; is a kind of drill plough.

5 Pair of Koluppee, used in weeding grass, &c. in a grown field.

6 A kind of harrow, used in levelling the ground after it is ploughed.

7 Regtey, used in planting tobacco and chillie plants.

8 A kind of harrow, used in spreading manure in fields.

9 Oil mill, used for extracting oil.

10 Sugar-cane mill, used for expressing the juice of sugar-cane in juice.

11 Wheel, used in drawing water from wells.

#### CLASS X.—Musical Instruments.

Guitar, kettle-drum, sarindah or fiddle, tomtom, trumpet, flute, cymbals, &c., from Moorsheadabad.

Collection of Musical Instruments sent by Baboo Futteh Narayun Sing, from Benares:—

1 Been. 2 Tumboora, a kind of drum. 3 Surroddi. 4 Sitar. 5 Pukhoujh. 6 Dhole. 8 Two dhookurs; three shandeas, and a pair of jhanjh (used in concerts). 9 Sarungee and bow, or Hindoostanee fiddle. 10 Sarindah and bow. 11 Chikarah and bow. 12 Khunjooree.

Several sorts of musical instruments, from Nepal.

Kind of kettle-drum, and toogna, from Bhotan.

Two guitars, contributed by the Rajah of Jodhpore.

Musical instruments, model of a tsignu wigu, and one complete, &c., from Moulmein.

Dyak violins, and Kayen guitar—Borneo.

Tsoung, or harp, tin box containing cymbals, model of a harp, patala, patma, or Burnese drum, cymbals used in religious ceremonies, &c., from Moulmein.

Set of musical instruments from Java, including gongs.

CLASS XI.—*Manufactures.—Cotton.*

Various pieces of plain and figured muslins, from Dacca.  
Various pieces of plain, bordered, flowered, and spotted embroidered muslins, from Baboo Soorop Chund Doss of Dacca.

Table-cloths, towels, dosootee and mosquito gauze, from Beerbloom.

Table-cloths, napkins, and towels, from Moorshedabad.

Various pieces of cloth sent by the Maha Rajah of Nagpore; also a few from the Resident, manufactured in the dominions of His Highness the Maha Rajah of Nagpore. The blue colour is obtained from indigo; the green from indigo and the seed of the chukora, but the dye is not lasting. The scarlet is dyed with kossoom. The yellow colour is formed of the flower of the hussinga, which is boiled with a little turmeric, and the thread is dyed previous to the weaving of the fabrics. The dark red is formed of indigo and safflower.

Pieces of towelling, table-napkins, cotton cloth, diaper, chintzes, and muslins, from Lahore.

Pieces of close-wove muslin, plain and cross-barred, from Bengal.

Gingham, five sorts, from Azimghur.

Nepaulce check for making quilts, from Nepaul.

Various cloths for dresses; carpeting, handkerchiefs; and different colours of cotton cloth, from Nepaul.

White cloth, used by Newars in funeral ceremonies to wrap up the body of the deceased; and red cloth, used by Newars in marriages and ceremonies, from Nepaul.

Twelve sorts of "Dorea" cloths, variously designated, and for different purposes, from Nepaul.

Canvas, for bags, &c., and threads of different colours, for making cloths, from Nepaul.

Coarse cotton cloth, worn by field-labourers, and exported to Ceram and New Guinea.

Cotton cloths, native produce by native tribes, Borneo, N. W. Coast.

Cotton cloths and tapes, from Celebes.

Cotton cloth, unbleached, from Boutan.

Cloth, from Sumatra.

Several pieces of cotton cloths, west native's, warp English, and native dyes, from Java.

Cloths, presented by his Highness the Sultan of Linga.

Bolt of cotton canvas, Bengal.

Naga cloth (cotton), white, black, and red, for coverings and chudders; (sheets,) from Assam.

Four pieces of cloth Mahmoodees, two dhooties, white turban Mundeel, manufactured in the dominions of the Rajah of Dholepore, in the state of Rajpootana.

Doriaya, Phoolkaree, Meetha, fine cloths for dresses, manufactured in the State of Gwalior, and contributed by His Highness the Maharajah Rao Scindiah.

Doputta, Patul, cloths worn in lieu of shawls by ladies in Gwalior, and contributed by His Highness the Maharajah Rao Scindiah.

Dress pieces, called "pugrees," for turbans, manufactured in the dominions of, and contributed by, the Rajah of Jesselmeer.

Doputtals, dhooties, one pugree, three muslins, manufactured at Chumdeyree. The cloths are much worn by natives of high rank; they are costly, and preferred to the finest European fabrics of a similar description.

Piece of coarse checked cotton, coloured; carpeting; guzzer, a sort of calico; garah, for dresses; chintz coverlets; quilted coverlets; lehafs; doosootee, for bedding and tents, &c., from Agra.

Garrah, a cloth manufactured at Agra. The trade in these cloths was formerly very great, but it has fallen off much since the introduction of English long cloths. The annual manufacture at present does not exceed 10,000*l*.

Calico, *garrah*. This cloth is manufactured throughout the division of Agra, and is chiefly used by the poorer classes; the annual consumption of it is about 50,000*l*.

Calico used by native ladies for dresses, Ganga, Saree, and Dhotees, manufactured in the division of Agra. The annual consumption is estimated at 20,000*l*.

Twelve chintz coverlets, Pullongposh, Furdhs, Lehafs, and Doosooties, used for quilted bed-covers. They are chiefly manufactured at Futtehghur and Coonoj, in the division of Agra, and their annual consumption is estimated at 10,000*l*.

Cotton cloths, from Sindh.

Six sorts of cotton cloths; cotton cloths for pantaloons and waistbands, from Belgaum.

Cotton cloths, from the Rao of Cutch.

Chintz mantle, from Khyrpoor.

Two sorts of cotton sail-cloth, from the Rao of Cutch.

Cotton fabrics from Ahmedabad, Surat, Sindh, Belgaum, Cutch, and Khyrpoor. They are manufactured from cotton chiefly grown and spun in the countries in which they are woven. Hardly any more are made than are required for home consumption. English spun-cotton is much used in Sindh, Cutch, and Surat.

Pieces of cotton cloth, striped and chintz pattern, from Seinde.

Fine punjum long-cloth, manufactured at Jugginpettah, in the Northern Circars, from Mr. Masters.

Muslin, from Arnee.

Muslin, manufactured at Oopada, in the Northern Circars.

CLASS XII.—*Woollen Manufactures.*

Cloth shawl, worn by natives, from Rampore.

Pieces of cloth, from Lucknow—His Majesty the King of Oude.

Woollen cloth, striped and checked, kid cloth, Cashmere and shawl cloths, from Lahore.

Box of wool and piece of camel cloth, from Seinde.

Superior blue cloth, from South Arcot.

Cumbeleys, blankets, &c., from the Ceded Districts.

Blanket, half-breed merino and butt wool, from Hoonsoor in Mysore.

Blanket, half-breed wool and of common country wool, from Hoonsoor in Mysore.

Wool thread of shawls, from Bhotan.

Piece of Pachin woollen cloth, from Jaomla.

Piece of goat's wool, of various colours, from Shiling.

Piece of goat's wool, of Toos, from Nepaul.

Cloth made by the Kirantees in the East, from Kirant.

Cloth of coarser kir from Nepaul and Bhoolan.

Woollen string, Hakpa with Ghoongroo, from Nepaul.

Blankets of wool and Asun wool, by the Rajalis of Jodhpore, Jypore, and Jesselmeer, from Marwar.

Several sorts of blankets, from Bhotan and Kachhar.

Specimens of articles commonly imported from Gartok to Bageswar, by the Jwari Bhotiyas, brought by Lieut. Strachey, Bengal Engineers, from Tibet:—

Kashmiri Pattu, of coarse shawl wool, from Kashmir *via* Ladak.

Coarse brown shawl, of goat's wool, from Balti.

White shawl, of goat's and ibex wool, from Balti or Kashmir.

The same, made up into a gown. Thick woollen stuff in coloured stripe, from USSANG.

White and coarse Nambu, for clothes. Coarse grey Pats; black and coloured stripes, for sacks, &c., from Nari Khorsum.

Black Nambu, for clothes, from Ladak.

Linzi.—Coarse China silks, from Yarkund.

Felted cloaks, called Baranees, from Goruckpore.

CLASS XIII.—*Silk and Velvet.*

Zhip (Turk). Sikim (Ladak).—Silk from Khoten.—Lieut. Strachey.

Silk thread and twine, and pieces of silk cloths, variously designated, from Moorshedabad.

Printed silk handkerchiefs, twelve varieties. Choppas. The silk handkerchiefs are made at Berhampore, in the division of Moorshedabad; the printing done near Calcutta. They form an article of considerable export to Europe and America.

Cossimbazar silk corahs, and skeins of raw silk.—Messrs. Vardon, of Soojapore.

Pieces of silk handkerchiefs, from Moorshedabad.

Two bundles, containing two seers of coloured silk.

Striped silk, of sorts; plain silk, of sorts; silk scarfs; and silk cloth; from Lahore and Rajah of Pattiala.

Silk scarfs, striped silk of various sorts and colours, &c., from Lahore.

Six varieties of Tussar silk cloth, produced in the district of Bhaugulpore, in the division of Patna.

Twilled silk, cloth Tussar, manufactured in the district of Beerbhoom, in the division of Moorshedabad.

Raw and coloured silks; raw silk and thread from the castor-oil worm; Mungah and Ariah silks; scarfs; waist-cloths; and bed-curtains; from Assam.

Pieces of different coloured silk, complete assortment of raw silk, and piece goods.—D. Jardine, Esq., Calcutta.

Lady's flowered and Tartan silk dress piece; two pair of silk scarfs, with flowered border; from Bancoorah district, Moorshedabad.

Red and yellow satin.—Manufactured in Cutch. The raw material from China. The silk is dyed in Cutch.

Silks (Cutch). Manufactured chiefly for home consumption. The raw material from China and Calcutta. The silk piece called "Elacho" is manufactured principally for exportation to Zanzibar.

Silk gown pieces, from Tama. These are imitations of English silks. The raw material comes from China, and is dyed at Tama.

Silk (Sindh). Chiefly manufactured for home consumption, from raw material brought from China.

Loongees (Sindh). Two were brought from Kurrachee, and two were expressly ordered for the Exhibition, and were manufactured at Tatta.

Piece of silk, from Poona. This is a very curiously woven silk, being of two colours, one side red, the other green; it is called "pytance." The raw material is brought from China or Calcutta, and dyed in Poona.

No. 2 are nine patterns of silk of an inferior manufacture to that mentioned.

Silks (Surat). These are manufactured in China, and dyed at Surat. No mention is made of the quantity manufactured for home consumption, or for exportation. They are the common patterns worn by the Parsee women in Bombay.

Purple silk, scarlet on one side, and small patterns of silks for choolies, from Ahmednuggur. These are made at Yeola, a place famed for the manufacture of silks. The value of the silks made annually at that place is stated to be from two to two and a half lacs of rupees.

"Of this, a quarter of a lac in value is consumed in the Ahmednuggur Zilla; half a lac is sold at the fair of Moheem, in Kandish, for transmission to Indore, Oojien, Cutch, Bombay, Surat, and other places in India; quarter of a lac goes to Berar; 10,000 rupees worth to Sholapoor; quarter of a lac is made up into borders, &c., of cotton piece goods locally consumed in the neighbouring districts; and the balance is said to consist of silks dyed, but unfinished, which are exported from Yeola to other places for completion."

"The raw silk comes from China. The dyestuffs, except a portion of indigo (produce of Kandish), and a few unimportant ingredients, are likewise imported through Bombay."

Pieces of ribbon, from Ahmedabad. The materials from which these are made, and the red dye, are imported from the places just mentioned. The value per annum of those manufactured for Ahmedabad amounts to 20,000 rupees; of those manufactured for exportation, 100,000 rupees. They are sent to Baroda, Bombay, Rajpootana, Gwalior, and all parts of Guzerat.

Raw silk (three specimens), from Azimghur.

Silk manufactured at Bangalore.

Different colours of silk threads, from Cuddapah.

Various pieces of coloured silks, of different designs and patterns, from Nepal.

Pieces of red silk, from Bhotan.

Pieces of yellow, orange, and black silk, from Nepal.

Salendong silk, from Acheen, Sumatra.

Sarongs or petticoat silks, from Palembang and Acheen, Sumatra.

Silk cloth, from Camboja.

Trousers' silk, from Acheen, Sumatra.

Silk tape, from Celebes.

#### CLASS XIV.—Manufactures from Substitutes for Flax, Hemp, &c.

Two coils of Jute rope; bolt of Chandernagore hemp canvas; bolt of hemp and cotton canvas—Bengal.

Rigging of Bombay hemp; warm and cold register coir rigging (first manufactured in India); Jubbulpore hemp; Dhanchee hemp rope; and pine-apple flax rope—presented by the manufacturers, Messrs. W. H. Harton & Co., of Calcutta—from Calcutta.

Gunny or sackcloth, from *pat*, or *Corchorus olitorius*.

Gunny and other cloths from plantain fibre, from Madras.

Canvas from Wackanoor or Wackoo nar fibre, from Travancore.

Two bundles of cotton, canvas, and rope, from Bengal.

Specimens of cordage from fibres of various plants.—(See Fibres, Class IV. (F.))

Ropes prepared from the *Dhanchee*, or *Æschynomome cannabina*.—Messrs. Thompson and Co., of Calcutta.

Cordage from *Butea frondosa*, Beerbhoom.

Cordage from *Bauhinia racemosa*, Bhaugulpore.

Cordage prepared from vegetable substances by the natives of the province of Arracan.

Bark cloth, manufactured by the Semangs or Oriental negro tribes, from Kedah, Malay Peninsula.

Bark cloth, made from the bark of the paper mulberry, from Kailli, west coast of Celebes.

Bark cloth, made from Papyrus bark, from Java.

Cloth manufactured by Arafuras from native fibres.

#### CLASS XV.—Mixed Fabrics, including Shawls and Scarfs.

Silver enwrapped, plain gilt, and silvered turbans—from Calcutta.

Fine cloths for dresses, shawls, and turbans; gold embroidered cloths worn by Rajpoots, and used for turbans—sent by Maha Rajah Rao Scindiah.

Several pairs of sheets, embroidered with gold and silver, and gold and silk, and a turban with gold ends—from Bengal.

Piece of gold cloth; silver tinsel stamped; gold edging; and silver edging, rose coloured—from Benares.

Head covering worked with gold and silver tinsel; the same, with gold dyed purple tinsel; the same, with sky-blue bobbinet spangled tinsel—from Benares.

Gold embroidered manufactures—from Benares.

Silk dress-piece, worked with gold and silver; scarlet silk dress-piece, worked up with silk in needle in imitation of China work—from Calcutta.

Embroidered flowered silk and silk embroidered saree, from Agra.

Embroidered shawls and embroidered scarfs, from Dacca.

Embroidered and net scarfs; net square and three-cornered; neck scarfs; muslin, embroidered in gold and silver; net scarf, embroidered in gold for head-dresses; net scarf, embroidered in silver—from Dacca.

Gold embroidered muslin and net scarfs; net scarf, embroidered in silver; Jamdane scarfs—from Dacca.

Rich kincob or brocade, &c., from Benares, exhibited by Baboo Deo Naryan and Gopinauth Debeersaad, &c.

Cashmere shawl, worked in green, crimson, blue, and scarlet, and embroidered in gold and silver.—A. Emerson, Esq.

Long shawls, red and green, and worked with needle; square cashmere shawls, from Loodianah.

Long and other shawls, from Cashmere.

Long shawls, white; square shawls, black, blue, and figured, from Maha Rajah Goolab Sing, of Cashmere.

Tinsel tape, ribbon, and thread, from Lahore.

Caps, embroidered with gold and pearls; with other fabrics, from Benares.

Half shawls and scarfs worked with gold, silver, and silk, from Delhi and from Rajpootana.

Long, square, and small shawls, green, blue, and black; worked shawls, red, with pearls, from Cashmere.

Shawls, black, white, and red; shawl scarf—from Rajah of Pattiala.

Infant's robe, embroidered grass cloth—from Mrs. Marshman, Serampore.

Muslin mantillas, jackets, and collars; pine-apple cloth and collars; muslin caps; pine-apple cloth caps; frock bodies and sleeves—embroidered; worked by natives of Calcutta.

Waistcoat dhootee, cotton and munga mixed; chupeun or overall coat; scarfs, gold bordered, and embroidered in gold—from Assam.

A pulla, doputta, &c., for dresses, from Agra.

Shawls of various colours and patterns—from Rajah of Dholepore.

Straw-coloured, lilac, red, and crimson kincobs; red and white mundeels; striped, green, red, and saree red lailahs; maymoodee; and dhoties, with silk border—from Rajah of Dholepore.

Mooltan and cotton and Cashmere scarfs, from Lahore and Cashmere.

Scarfs of different colours, from Maha Raja Goolab Sing of Cashmere.

Scarfs, &c., from Huzara. Major Abbott.

Figured cloth, from Khyrpoor.

Waistcoat piece; cap pieces; tinsel ribbons; bed strings; strings for the hair, from Lahore.

Mixed silk and cotton, imitation Sultaree silk.

Mooltan tambour work; Mooltan busmedars.

Boorhanpore fabric brocade, and pattern of same, from Indore.

Fabrics from Boorhanpore. "No. 1 was made to the order of her Highness the Baizee Ball, for one of the presents to Maharajah Sindiah on his marriage. The price charged her Highness was 1,000 rupees (Chundaree); but the real value is 550 rupees (Cor).

"Nos. 2 and 3 are also manufactured at Boorhanpore. The thread (cotton and silk and gold), of which they are made, is prepared at Boorhanpore. No mention is made of the places from which the materials originally come."—*Bombay Report*.

Brocades, silk and gold, from Ahmedabad.

Fabric of silk and gold from Ahmedabad. The silk from which these brocades are manufactured comes from China, Bassorah, and Calcutta. The gold and silver thread is manufactured at Ahmedabad. The cochineal for the red dye from England. The quantity of these brocades, manufactured for home consumption, is about 40,000 rupees' worth per annum. The average value of that exported, about 300,000 rupees' worth per annum. They are exported—to India, Bombay, Baroda, Poona, Gwalior, Hyderabad, and Rajpootana. Out of India—to Sindh, Cabool, Arabia, Persia, and China.

Square shawl from Seth Khunr Chund, of Ahmedabad.

Loongee, with gold thread border, and gold thread, green, red, white, and yellow; the same, red, black, and yellow, from Scinde.

Pattern green and orange silk, with gold thread; piece of green silk, with gold thread—from Ahmednuggur.

Silk scarf from China produce, and raw pine-apple silk, chickoned, and worked by Mussulmen; worked muslin dresses; beetle-wing dresses; lace scarf—from Madras.

Fine cottar muslin, with gold lace border; cottar muslin, unwashed, with gold lace border—from Travancore.

Kincob silk, from Trichinopoly.

Cloths woven, plain red, with silk; cloths woven, purple and black; cloths woven, red, with lace—from Guntoor.

Scarfs, embroidered with gold thread, from Tringanee and Pabang, Malay Peninsula.

Silk handkerchiefs and shawls, from Tringanee, Lingy, and Timor.

Scarfs, cotton, and dyes of native growth; raw silk from the continent of Asia—from Sumatra.

Salendongs silk, from Acheen, Sumatra.

Embroidered cloth, from China, and embroidered tape, from Celebes, forwarded from Singapore.

Turbans and lailahs—from Tonk.

Pieces of silk and cotton manufacture.

Piece of chequered cloth, silk and cotton.

CLASS XVI.—*Leather, including Saddlery and Harness; Skins; Furs; Feathers; and Hair.*

Embroidered elephant trappings in velvet, and frontal piece; embroidered awning in velvet, with embroidered cloth carpet; saddle-cloth in green velvet, and embroidered in gold, with head-stall to match, and rein—from Moorshedabad.

Mahratta saddle embroidered with gold and silver thread, and accoutrements complete, as used by the Mahratta nobility—from Maha Rajah Rao Scindiah.

Horses' bits; reins for a bridle; saddle-cloth stall and crupper.

Saddle-cloth, green and gold, with head-stall and crupper, all studded with gilt nails—from the Rajah of Kotah.

A complete set of single harness, belonging to the "Ekka," or native conveyance, No. 1365, manufactured in the division of Patna. Presented by Syud Luft Ali Khan.

Saddle-cloth (floss silk and woollen)—from Kotah.

Mahratta leather and water-bag.

Embroidered saddle from Khattiarwar. This is one of the saddles used by the Khattys of Khattiarwar, the descendants of a tribe of freebooters, whose horses were famous for their endurance, and the extraordinary length of marches that could be performed with them.

One set of harness, for gig or stanhope; also two pair of boots, as specimens of the workmanship of Calcutta workmen. "The harness is entirely of country materials, with the exception of the japan leather, which is English. The leather is of the up-country bullock hides, tanned in our own tan-yard, in the neighbourhood of Calcutta, with the 'bauble' bark, called, we believe, the 'prickly mimosa;' the plated furniture and arms of Great Britain are made up on our own premises by native artists. One pair of boots are made with French japan leather and morocco legs, and the soles, &c., of country leather; the other pair of enamelled leather of our own manufacture, and entirely of country materials and native workmanship."—*Extract of a letter from Messrs. James Monteith & Co., dated Calcutta, 7th March, 1851.*

Bengalee-made horsewhips.

Buffalo leather, manufactured for the purpose of army accoutrements; Bengal cow-hide, and a calf-skin, both tanned with the bark of the Babool tree, dressed and patent enamelled, for the purposes of carriages, and boot and shoe makers; specimens of Bengal cow-hide, similarly tanned with the same substance, the former dressed black, the two latter brown; half a buffalo-hide, tanned with Babool bark, suited for boot and shoe makers, and machinery; half a Bengal buffalo-hide, similarly tanned, and suited for harness and other purposes; half a buffalo-hide, used for belts, and other purposes of machinery; half a buffalo-hide, dressed and blackened for the preparation of horse harness; Bengal cow-hide, used in the preparation of saddlery; Bengal calf-skin, dressed brown, for shoe and harness-making purposes; Bengal sheep-skins, for shoe and harness-makers' purposes—from Messrs. TELL & Co., of Calcutta.

Tanned bison skin—from Mysore.

Buffalo-hide, tanned and dressed black; bullock-hide, tanned and dressed black, for shoe uppers; tanned and dressed brown and black, for caps, bags, &c.; bullock-hide, tanned and dressed, buffed; Neighery buffalo-hide, buffed—from Hoonsoor, in Mysore.

Dyed hides of fine colour—from the Rao of Cutch.

Saddle, &c., complete—from Lahore.

Camel's saddle, and horse saddle, with trappings complete—from Marwar.

Raw feathers; boas; artificial flowers; tippets, manufactured by natives; grey, white, black, and swansdown boas; grey and white muffs; Commercolly muffs; fur muffs for the neck; victorines—from Commercolly, Bengal.

CLASS XVII.—*Paper, Stationery, Bookbinding, Printing, &c.*

Paper made from *Daphne cannabina*—from Kemaon. It is remarkable for its strength, and affords better protection against dampness than wax cloth.

Kamptee paper—from Assam.

Sheets of paper, Nepalee Kaguj—from Nepal.

Sheets, both coarse and fine, and of very large size, made from the inner bark of *Daphne cannabina*, exhibited by Lieut.-Col. Sykes and by Lieut. Strachey.

Rolls of coloured paper—from Lahore.

Paper, from plantain fibre, and from large aloe or agave—from Dr. Hunter, of Madras.

Nine sorts of paper—from Ahmedabad.

"Country paper," as it is termed, is manufactured to a great extent at Ahmedabad, and forms a considerable article of export from that city. The manufacturers admit that upwards of 20,000 rupees' worth of paper is annually exported to Bombay alone, and about 15,000 rupees' worth to Baroda. There are small manufactures of country paper at Kairie, Baroda, and Selaseer, but chiefly from refuse of paper and very little raw material, and therefore the article does not turn out good; whereas, at Ahmedabad, paper is manufactured from hemp tant from Merywur. Soap from the town of Besulnuggur, and soda (sajee khor). There are about 250 paper mills, or pounding machines, worked by the feet. This manufactory gives employment to upwards of two thousand labourers of all ages daily. There was a very fine kind of paper formerly manufactured expressly for posting letters and bills of exchange; but since the introduction of fine letter-paper from Europe, this sort of paper is not manufactured. A few quires can now be obtained as specimens of the manufacture of former days."

Specimens of bookbinding by a native of Trichinopoly, exhibited by T. E. J. Boileau, Esq., Bombay Civil Service.

CLASS XVIII.—*Fabrics of different kinds, shown as specimens of Printing or Dyeing.*

Though the arts of dyeing and of calico-printing have been practised in India from the earliest times, and by some are supposed even to have originated there, no goods have been sent expressly as superior specimens of either the one or the other art. But among the cotton, silk, woollen, and mixed fabrics exhibited as Classes XI., XII., XIII., and XV., are many beautifully-dyed articles, and a great variety of prints which may be admired for the taste and elegance of their patterns. The early esteem in which these were held in Europe, is evidenced by the oriental names of many of these Indian goods being applied even in the present day to these English imitations. The art of dyeing is still in a rude state in India, as far as the methods adopted are concerned; yet if we look at the results which are attained, they are not to be despised even by the side of the scientific dyeing of the west. But in the management of colours, the skill with which a number are employed, and the taste with which they are harmonised, whether in their cottons or their carpets, their silks or their shawls, Europe has nothing to teach, but a great deal to learn.

CLASS XIX.—*Tapestry, including Carpets and Floor-cloths, Lace and Embroidery.*

Gold embroidered velvet carpet, with a long and two

square pillows, forming a sort of throne for native princes, from Moorshedabad.

Musnud cover or shawl, very richly gold embroidered.

Cotton carpets (*Satrunjees*) of different sizes—from Bengal.

Mirzapore woollen carpets; woollen and cotton rugs—from Mirzapore and Goruckpore.

Two cotton carpets—from Shah Ahmed of Sasseram.

Rug and hookah carpets—from Moorshedabad.

Cotton carpets and rugs—from Rungpore, district of Moorshedabad, and from Agra.

White, coloured, and striped blankets—from Assam.

Embroidered hookah carpets—from Bengal.

Richly embroidered carpets in gold; gold embroidered velvet carpet; embroidered velvet carpet—from Benares.

Cashmere carpet, silk—from Lahore.

Silk-embroidered carpet—from Mooltan.

Silk carpet, Cashmere—from Lahore.

Carpet, silk Cashmere—from Cashmere.

Carpet, cotton—from Mooltan, Lahore.

Carpet for silver bed to stand on; a large carpet, Cashmere; carpet—from Maharajah Goolab Singh.

Mooltan printed floor-cloth—from Mooltan.

Woollen carpets, mounted with silk—from Khyrpoor. These form a part of H. H. Meer Ali Morad's contribution, and were unaccompanied by any descriptive list.

Embroidered silks from Khyrpoor. They are sent by H. H. Meer Ali Morad. It is presumed that they were embroidered at Khyrpoor, on manufactures of the same district.

Large and small broad-cloth table-covers, embroidered with silver and gold thread; broad-cloth table-cover embroidered with silver thread; velvet chair-covers, embroidered with gold, from Sindh.

Table-covers, specimens of embroidery from Sindh. The cloth is from England—the silk from China. The town of Tatta is most famous in Sindh for this work.

Printed cotton carpet—from Ahmedabad.

Cotton carpet—from Ahmedabad.

Rugs, woollen—from Ellore.

Flowered silk carpet—from Madras.

Small woollen and silk carpets—from Tanjore.

Silver lace—from Lahore.

Broad black lace; broad, gold, and silver blonde lace; broad and fine lace—from Travancore.

An infant's robe of the finest grass cloth, and embroidered by hand, by natives of Serampore near Calcutta. Contributed by Mrs. Marshman, of Serampore.

Jackets, collars, caps, frocks, boddices, and embroidered mantillas, worked by natives in the city of Calcutta.

Chikun worked flowered muslin chudders, 2 pieces, worked by natives in the city of Calcutta.

A scarlet silk dress-piece, worked in imitation of China embroidery. Worked by natives in the city of Calcutta.

Silk scarf from China produce and pine-apple fibre, chikun (embroidered) by Musselmans of Madras. Contributed by Mrs. Goodsir.

Handkerchief of pine-apple fibre. Contributed by Mrs. Goodsir.

(H) *Quilted or padded.*

A quilt, Razace, and two pillows, Takeeah. Manufactured in the dominions of the Maharajah of Jodhpoor, in the states of Rajpootanah.

A quilt entirely worked by hand. Contributed by the Rajah of Kota.

CLASS XX.—*Articles of Clothing, &c.*

From Bengal.—A Kamptee dotee or male dress. Pat dhootees, male dresses. Poosong, Pat silk, a female dress. Ranga, Pat sooria, native substitute for trousers. Pat rehas, scarf for females. Bogue pator surah or dhoty, native trousers. Pat meekla, female dress. Pat dhootees, male dresses. Areah for wearing apparel. Areah bhar kossar. Areah bor kossar, male and female dress. Reha female dress. Reha mikla female dress. Areah, coloured,

Mikla, coloured silk. Cloth, red and white. Gungera, red and white, for women's dress. Mikla, coloured. Munga areah, cotton cloth. Munga dhotee, for men. Munga mikla, for females. Munga rea. Munga rea, searf. Mikla or Petticoat. Dhotee. Phakeel tartan.—From Gowhattee, in Assam.

Silk mehganckhore for male dress. Petticoat. Handkerchief.

A wrapper worn by both sexes. A dress worn by nobility. A wrapper challah for nobility. Singpo bag, possa, and tactins.

Embroidered caps. Purse worked with tinsel.

Fan, worked in a variety of embroidery, with silver-gilt handle. Red silk strings for trousers, with gold and silver tassels. Sky-blue bobbinet scarf, worked with silver and silk. Crimson bobbinet scarf. Pair of crimson bobbinet scarves, worked with silk. Sky-blue bobbinet scarf, worked with silver. Orange bobbinet scarf, worked with gold. Black bobbinet scarf, worked with gold. Black bobbinet scarf, worked with gold and silver. Square scarf, white bobbinet silk. Orange scarf, gold and silver. Square scarf, orange, gold and silver. Square scarf, crimson, loose erape, spangled. Green scarf. Head-covering, set with bits of glass. Head-covering, worked with silk. Cloth boddiced dyed blue. Pair of cloth rings, ornamented with eowries, for securing the water-pot on the head.—Delhi.

Sosnee or quilt, worked by hand, and made of Ihatia patum.

Suit of a native gentleman's apparel, viz.: a gold figured muslin turban, according to the Bhoondee shape, a waistband to match; a pair of kinkob drawers, and a muslin vest—the usual dress of the Rajah of Boondie. Suit of ladies' apparel, viz.: a handsome petticoat, gold embroidered veil and head-dress, and a bodice worked with lace and tinsel. These articles form the usual dress of the Rajah and Rancee of Boondie in the Rajpootana States, and have been contributed by the Rajah.

Doputtahs or garments worn by ladies of Jeypore, richly worked in silver, and printed in gold. Turbans, called Chundree and Liehruja, worked in gold. Sungahar handkerchiefs for tying round the head; ehintzes for dresses; waistband cloths; and mantles or sheets worn over the shoulders.—States of Jeypore.

Ghoochus or blankets, a protection against rain. Chuekmahs or blankets. Blanket usually spread on the floor. Blanket with silk edging.

Native gentleman's apparel, viz.: two turbans, called Choongree, made at Kota; full-dress turban; waistband, selah, white muslin gold flowers; piece muslin, gold stamped; piece brocade knee for drawers; and two pieces striped muslin, Doreeah, for jackets. Ladies' apparel, viz.—petticoat, green silk stamped with gold; head-dress and veil, gold bordered; red veil, figured; choolie or stays. Worn by the people of rank in Kotah.

Puggrees, or turbans, of Jesselmere wool.

Silver-worked searfs. Silk searfs, gold-edged, white, orange, and puce colour. Silk searfs, yellow and plum colour. Cotton searfs, from Lahore.

Women's and men's shoes. Cap and tassel. Head-dress worn by Akalis, Lahore.

Trousers, dresses, searfs, and shoes, from Maharajah Goolab Sing.

Dress bodice, trousers, undergarment, sheet, pair of shoes, gown, bundle hair-strings.—Rancee Sookhan.

Cloak, sheets, turban, pieces shawl stuff, and scarf, jacket, pantaloons-strings, sets bed-strings, woollen eap, waist-ropes, Chumba dress, pair sheets, and turbans.—Raja of Pattiala.

Piece Major Abbot's Huzara Soojie cloth, Loongie. Caps embroidered with gold and pearls.—Benares.

Kareem man's dress. Poongas priest's dress, upper and lower garments. Burmese gentleman's dress. Kareem woman's dress, lower garment, and searf. Burmese ladies' dresses of the second class. Upper garment of coloured cotton. Kareem male and female dresses. Sandals.—From Moulmein.

Crown, or tuj, as worn by the King of Oude; without jewels.

Mundil, or turban, as worn by the minister, prince, and members of the royal family; from the King of Oude.

Doputtas and other articles of dress. Puggrees, or turbans. Selahs, or double doputtas. Dhooties. Kochos, or kummur bands. Saries. Piece of common silk. Gold and silver embroidered slippers. Common slippers. Marhatta child's turban.—From H. H. the Maharajah of Nagpore.

Wearing apparel. Musquito curtains. Native ladies' dresses, of white and black watered silk. Set of bed-curtains, as used by the higher classes. Embroidered waist-belt. Coloured muslin turbans.

Native dresses. Duneya: cross-striped, &c. Gudka ehent petticoats.—From Agra.

Delhi worked puehchasse in pearls.

Bengalee wooden sandals. Native-made slippers and boots.

Mahratta children's turbans, from Nagpore.

Native lady's bodice, richly embroidered. Waist-belt, embroidered in velvet and gold.

Shoes for men and women.

Waistcloths, called Dhotee. Petticoats, called Maekelah. Scarves, called Reha. Ornaments for turbans—from Assam.

#### *From Madras Presidency.*

Lady's scarf, English shape, from Vizianagram.

Lady's pocket handkerchief, of Indian produce, pineapple fibre, from Madras.

Lady's searf, English pattern, from Vizianagram.

Native female clothes. Boys' tinsel and silk caps—from Vizianagram.

Caps (moplah), of sorts, from Calicut.

Bodices of different patterns, for natives, from Madras.

#### *From Bombay.*

A dress of a Cutch lady of rank, manufactured in Cutch, from the Rao of Cutch.

A complete suit—"The dress of a native (Mahomedan) female of rank, which has been made up and prepared by her Highness the Seemdee Begum of Bhopal."

Dress of a Hindoo woman, whose husband is alive. Manufactured at Rancee Bidnoor, in the Dharwar Colleetorate.

Dress of a Hindoo widow, Belgaum.

Dhoter furuspatee used by men, Belgaum.

Cholees or khuns, &c. Used for making spencers for women whose husbands are alive; also the dress called purkara, resembling aprons, for girls under five years of age. The raw material is brought from China through Bombay, and is dyed in the Southern Maratha country. These silks are manufactured almost entirely for local consumption.

Silk goojees, shirts and mantle, Scindee hats and fans. These articles from Khyrpoor are contributed by H. H. Meer Ali Morad.

Chooles, or bodices, and body garments, from Ahmednuggur.

Embroidery of Cutch. These four aprons have been worked on English satin, with silk imported from China.

Embroidered silk vests (Surat).—The fabric is woven at Surat, from China silk dyed there, and then embroidered and made into vests for the Parsee children of the place.

Boots and shoes (Sindh). These show the kinds of boots and shoes worn in Sindh and the neighbouring countries. They are from H. H. Meer Ali Moorad.

#### CLASS XXI.—*Cutlery and Edge Tools.*

Silver-mounted carving-knife and fork, in silver-mounted velvet case—from Trichinopoly. A. Freese, Esq. M.C.S.

Knife—from Cashmere.

Carvers and a set of dinner and desert knives of Indian steel, with buckhorn handles and silver ferules, made by a native iron smith at Trichinopoly, exhibited by T. E. J. Boileau, Esq., M.C.S.











Betel-nut cutters; pen knives—from Benares.  
 Barber's utensils; a case for instruments—from Bengal.  
 Knives (chhooree)—Nepaul—from China.  
 Different sorts of knives used by females—from Nepaul.  
 A knife; another sort (chipee) to cut wood; another knife, used by Mugar and Gooreng tribes; another to cut vegetables; another used by butchers; razor (ustoorā)—from Nepaul.  
 Hunting-knife, with bukhorn handle, silver mounted; velvet case, silver mounted—from Vizianagrum.  
 Firungicuttee; Nimacha; Thagah; Hindoostangsigah; Nindoovarāh soora cutty; Gooptee; Firungicutty; Prishentzoo; Kygaroo; Kyzaroo; Bakoo; Booranpooree; Patanee; Bondalekhata; Sectearmporee; Jamdadoo; Chelaneh; Kataroo; Pieshcubzoo; Andamaroo—from Vizianagrum.  
 Betel knife (notu kuttaree; tamool kuttarees,) knives used by natives of rank; kampte dooe, for cutting wood; Abro and Naga dooe, weapons—from Assam.

CLASS XXII.—*Iron and General Hardware.*

Metal goglet used by natives of Malabar—from Calicut.  
 Iron pans and iron spoons—from Chota Nagpore.  
 Wire—from Cuttack.  
 Brass peacock lamp—from Agra.  
 Six vessels of brass, made at Patna.  
 Vessels composed of zinc and copper—from Moorshebada.  
 Brass manufactures, viz.—Brass plates, cups, vessels, and cooking utensils—from Agra and Mirzapore.  
 Cooking utensils, consisting of copper, brass, and pewter plates, and a variety of cups, vessels, and other domestic articles, from Assam, Calcutta, and Moorshebada.  
 Miscellaneous collection of articles in metal, used in worshipping, and for domestic use—from Nepaul.  
 Large and small Bidree hookahs, from Rajah of Dholepore.  
 Seven specimens of bell metal—from Kotah.  
 Steels for striking light, and tweezers—from Rajah of Jesselmere.

CLASS XXIII.—*Jewellery, Works in the Precious Metals.*

The Durria-i-Noor, or the Sea of Light diamond, set as an armlet, with ten smaller diamonds surrounding it.  
 Large pearl necklace, consisting of 224 large pearls.  
 Shorter one, of 104 large pearls.  
 Short necklace, of four very large spinelle rubies.  
 Pair of emerald armlets, three large stones in each.  
 Carved emerald and diamond turban ornament.  
 Set diamond and emerald bridle and martingale.  
 Gold-mounted saddle, set with diamonds, emeralds, and rubies.  
 Pearl robe and emerald girdle of a Sikh chief.  
 Glass case, with silver filigree ornaments; head ornaments; bracelets; brooches; umbrella; elephants' hair bracelets; hair pins; neck chain; girdle; flower holders—from Cuttack. These filigree silver ornaments, which are only worn by Europeans, have been manufactured by the native silversmiths of Cuttack. They are remarkable for their extreme lightness, neatness of workmanship, and cheapness.  
 Enamelled lutchkas; Gotah hars or garlands; gold and silver lutchkas; gold and silver gothas—from H. M. the King of Oude.  
 Glass bracelets; beads of silver, hollow; small globes of glass, silvered inside—from Delhi.  
 Buddha necklace; ornaments worn in turbans; gold and silver wire—from Rajah of Jeyppore.  
 Silver toys—viz., Deer-fighting, ram-fighting, combat with tiger, wrestlers—from Rajah of Kotah.  
 Armlet engraved, iron gilt; gold thread, from Gwalior.  
 Silver golabas or rosewater bottles, embossed in gold, made in Calcutta.  
 Silver filigree, worked uterdun, or uter holder. Cuttack

silver filigree flower-basket. Manufactured by the native silversmiths of Cuttack. The holder, or the uterdun, is filled with cotton dipped into oil of roses and placed on a table, thus diffusing fragrance throughout the room.

Silver goojree; punchum and mulls; pair of silver pyjore; mulls; bottles, for rosewater; silver mulls; uter stand; gold ear-rings, from Calcutta.

Gold and silver thread from Moorshebada.

Gold and silver filigree work from Dacca.

Chain ornaments for the head; ear-rings; ear ornaments; neck ornaments; pendant; armlets; ring for the thumb, and nose-ring; ornaments for the feet; neck-chains of gold and silver, such as are used by the natives of the North-west Provinces, and manufactured in the city of Delhi.

Bangles of white ivory and red, and of various colours; bangles worked with gold; buffalo horn, brass-mounted clasp; lac gilt and plain bangles; bracelets gilt—from Bengal.

Hookah bottom in silver; cocoa-nut and silver mounted, manufactured in Calcutta.

Silver flower-cases gilt; silver filigree worked spice-box, from Mirzapore, by Baboo Murhut Parsramgeer.

Diamond armlet, necklace, and ear-ring; necklace, with a star and emeralds; string of gold mookree; gold beads, armlet, and wristlet, &c., from Calcutta, and as worn by the better class of native ladies, and manufactured by the native silversmiths of Calcutta.

Gold necklaces and bracelets, made at Agra.

Silver box, and other articles, from Rajah of Ulwar.

Necklace of pearls, with diamonds and emeralds; diamond ring, bangles set with jewels; necklace of jewels and pearls; necklace of pearls; garland of pearls; armlets; ear-rings; bracelets; uter bottle; goolabdan for rosewater; pandan, spice-stand; plate—from His Highness the Rajah of Dholepore.

Plate of silver embossed; goolabdan partly gilt; silver bottle; drinking mug and cups; small box, partly gilt; pandan with cover; flower-pot of silver wire; 3 dice and 16 gold draftsmen; hookah ornamented with gold; glass case, containing a douree or necklake of gold, with two pendants; silver horse stirrups—from Rajah of Jodhpore.

A necklace of gold, and pair of bracelets inlaid with painted and gilt glass in imitation of mosaic, from the Rajah of Pertabgurh.

Silver plate with cover, jar and jug; silver bottle and stopper, ever, cup, and wash-hand basin—from Maha Rajah Goolab Sing of Cushman.

Ear ornaments—from Lahore.

Jasper cups; crystal cups; agate cups and jugs—from Lahore.

Crystal arm ornaments; pot and cover; jar and cover; jasper boxes, vase, and cup—from Lahore.

Tea-pot; agate bottle; jasper cup; onyx cup; paper weight, crystal; jasper leaf; imitation fish, silver; silver covers—from Lahore.

Pearl necklace, head ornament, bracelets, and diamond ring, from Rajah of Pattiala.

Anklets, silver; bangles, silver; ear ornaments, armlets, ear-rings; head ornament; drinking cup; enamelled silver cup—from Rane Sookhan of Seharuipore and from Kangra.

Gold moher and other coins; golden necklace, with silver chain; nose rings; golden ear-rings—from Nepaul.

Sandal-wood box, containing silver necklace and bracelets; rings worn round the ankle; silver armlet of Bhugwatee; Nepaul silver coins of one rupee; of eight annas; four annas; two annas; one anna; half anna; quarter anna; copper coin, double pie; copper coin, single pie; copper half piece; copper coin, quarter piece—from Nepaul.

Dhalee or gold necklace; Isoobangsey necklace; Bayet necklace; Burmese ear knobs worn by men and women; gold rolled ear knobs and bangles; silver betel box and waterstand, with stand; silver spittoon; small basket made of silver wire, from Tenasserim Provinces.

Male and female ear ornaments, from Assam, such as

are worn by the Burmese and manufactured in the Tenasserim provinces.

Golabdan with plates, one pair (Rao of Cutch). These are made in Cutch, and are specimens of what is called the Cutch silver-work in Bombay.

Necklaces and bracelets, from Poona.

Beads, from Guzerat.

Bracelets, agates, &c.; brooches of several kinds of stones; buttons, shanked; buttons, not shanked; necklaces; beads; brooches plain, of agate, bloodstone; buttons and studs, not shanked—from Ahmedabad.

Gourd snuff-boxes, mounted with gold and silver—from Seinde.

Specimens of gilt wire in its different stages, when under preparation for the manufacturing of the Boorhanpore fabrics.

For the description of this process, see the following paragraphs, with which a sketch was furnished by R. N. Hamilton, Esq., resident at Indore, before whom the specimens forwarded were prepared:—

Par. 4.—No. 1 is the silver as it is turned out of the furnace into a mould. The silver put into the crucible was 62 rupees of the ordinary local currency. The crucible No. 1 was formed of clay taken out of the small river "Panderal" which runs into the "Taptee" on the western side of the city of Boorhanpore. The furnace was formed of four common bricks laid on the earthen floor, a layer of charcoal placed at the bottom; on this the crucible, which was covered over entirely with charcoal, fanned by a hand punkha, a square bit of mat of four by nine inches, to increase the heat, and were occasionally thrown into the fire in small quantities; and in forty-seven minutes the silver was in a fluid state ready to pour into a mould, from which the specimen No. 1 was turned out.

5.—No. 2 is a mould of silver beaten out and rounded, after which it is slightly filed, as shown, to allow the gold to adhere; this is simply washed in water, then well rubbed with a fresh-cut lime, and then washed in lime-juice and water; it is then moderately warmed, after which the gold No. 3 is folded over it, after which the bar is put into the fire, warmed, and then beaten with a hammer, and becomes as shown in specimen No. 4.

6.—Specimen No. 3 is the gold: before being put upon the silver bar No. 2, it is well washed with fresh lime-juice and water, and then boiled in this liquor; on being taken out it is warm, and easily folded on the silver bar No. 2.

7.—This is the entire process of plating the gold: after this the specimen No. 4 is placed opposite to one of the holes in the steel plate B (vide drawing), a small end, about three quarters of an inch, being left of the silver, on which the iron nipper (D) is fastened; the bar then is drawn through the plate B, until it assumes the sizes in specimens No. 5, and No. 6 is the last process in the workshop, before it is made over to the manufacturers.

8.—The manufacturers have still further to reduce the wire, which is done in a similar manner, only that instead of a windlass, two reels moving on pivots are substituted; the gold thread being wound off, one then passing through apertures in a steel plate of very small dimensions, and being wound on another reel, both are worked at once by one man, sitting, and by his hand giving velocity to either as may be requisite.

Specimen No. 7 is the gold thread on a reel, after having gone through the above process; it is flattened with a hammer, and becomes specimen No. 8, which is the identical bar (No. 4), after it has gone through every process, and is ready to be united with the silk (specimen Nos. 9 and 10). This is a simple process, a spindle of silk, No. 9, and a spindle of gold, No. 8, are taken by a man, and passed over a hook in a beam about six feet from the ground. Under this the man sits: he first twists the silk spindle by rubbing it along the calf of the leg (on which is a leather gaiter as a guard), and then the gold spindle; when both are in full spin, he regulates the gold by letting it run through the fingers of the left hand whilst keeping up the spinning of each reel, as necessary, with his left, as above described.

10.—Specimen No. 11 is the silk and gold thread as used in the manufacture of brocade and tissues, specimens of which I have already sent to you.

11.—The cost of each specimen is annexed, and the value of the skein of gold thread, ready for use, is one rupee ten annas, and measures 200 yards of Boorhanpore measure.

12.—The cost of the labour of workmen in preparing these specimens was seven rupees, the profits one per cent., and the batta, or exchange from Boorhanpore to Company's rupees, 5 per cent.; the total value or cost of these specimens, including workmen's labour, profit, and batta, was 443 rupees.

Buffalo-horn snuff-box inlaid with metal, from Vellore.

Gold rose chain, from Trichinopoly.

Gold ear-rings, worn by native females, Nair caste; gold necklaces, worn by females of Malabar, Chuckur Mala, Elka Thali, and Valia Moodhurin; gold bangles, worn by males and females of Malabar, Latha Vale, and Boobum Vala; the same, worn by females of Malabar on the ankles; small knife, with pinchbeck and gold handle—from Calicut.

Gold and silver girdles and silver spice-case, from Vizianagram.

Female ornaments (two sets); neck, ear, and nose ornaments; Moodoo bangles; gold and silver inlaid Nair knives; silver ornaments, &c.—from Travancore.

Bangles; kais ring and cockatoo chain; finger rings; seal ring—from Celebes.

Gold ornament worn by Malay women of rank as fastening for waist-belt, from Singapore.

Bundle of brass and pewter jewellery worn by natives of lower order in Bengal.

Model in glass of the great diamond in the possession of the Nizam; description by Henry Piddington, Curator, Museum Economic Geology, Calcutta:—

"About twelve or fourteen years ago a large diamond was found in the Nizam's country under circumstances of rather a curious nature. The model now shown is the model of a part only, a piece having been chipped off, which after passing through many hands, was purchased by a native banker for 70,000 rupees.

"The larger piece, as represented by the model, is in the possession of his highness the Nizam, and at the time of discovery was exhibited to many European gentlemen.

"The manner in which this diamond was originally found, may be considered interesting. It was first seen in the hands of a native child, who was playing with it, of course ignorant of its value. On eight annas being offered for what the poor people considered as a mere stone, their suspicion was excited, which led ultimately to the discovery of the bright stone being a real diamond."

"The size of the stone exactly taken by callipers, from the leaden model, is as follows:—

|                             |         |
|-----------------------------|---------|
|                             | Inches. |
| Length . . . . .            | 2·43    |
| Greatest breadth . . . . .  | 1·35    |
| Average thickness . . . . . | 0·92    |

"I have had now exact models cut in glass from the leaden one exhibited at the meeting, and I find that

|                                    |          |
|------------------------------------|----------|
|                                    | Grains.  |
| Their absolute weight is . . . . . | 1,164·50 |
| Their specific gravity . . . . .   | 3·70     |

"Now according to various authorities we have for the specific gravity of the diamond—

|                                         |      |
|-----------------------------------------|------|
| Ure . . . . .                           | 3·53 |
| Brewster, colourless . . . . .          | 3·52 |
| orange . . . . .                        | 3·55 |
| Jameson, 12 authorities, mean . . . . . | 3·52 |

Mean . . . . . 3·52

"And hence assuming our model to be exact (and it is very nearly so), we have by a simple proportion not quite 1,108 grains for the actual weight of the Nizam's diamond.

"This is equal to 277 carats of weight for the rough



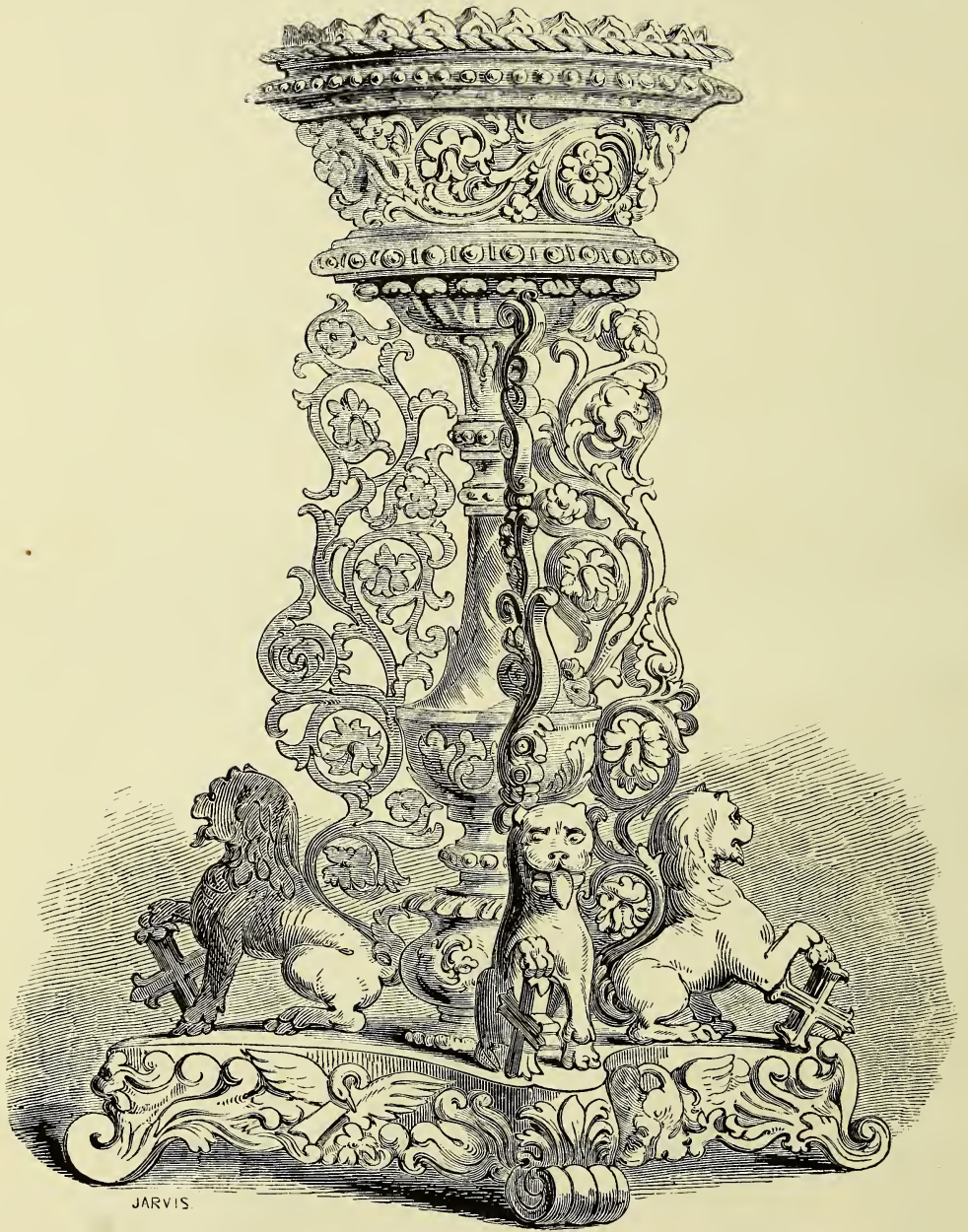

JARVIS





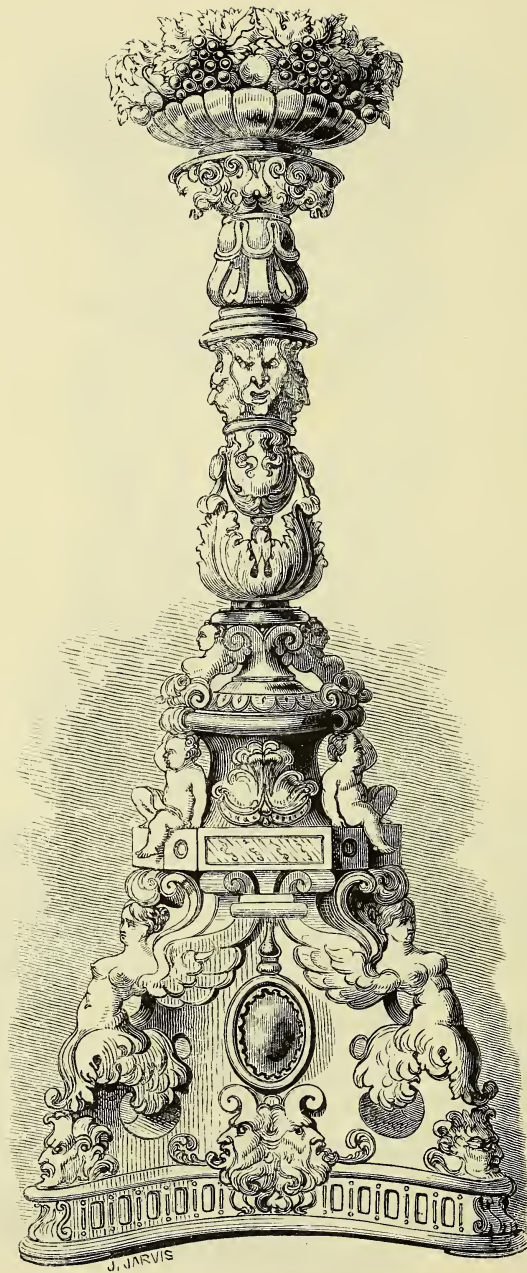







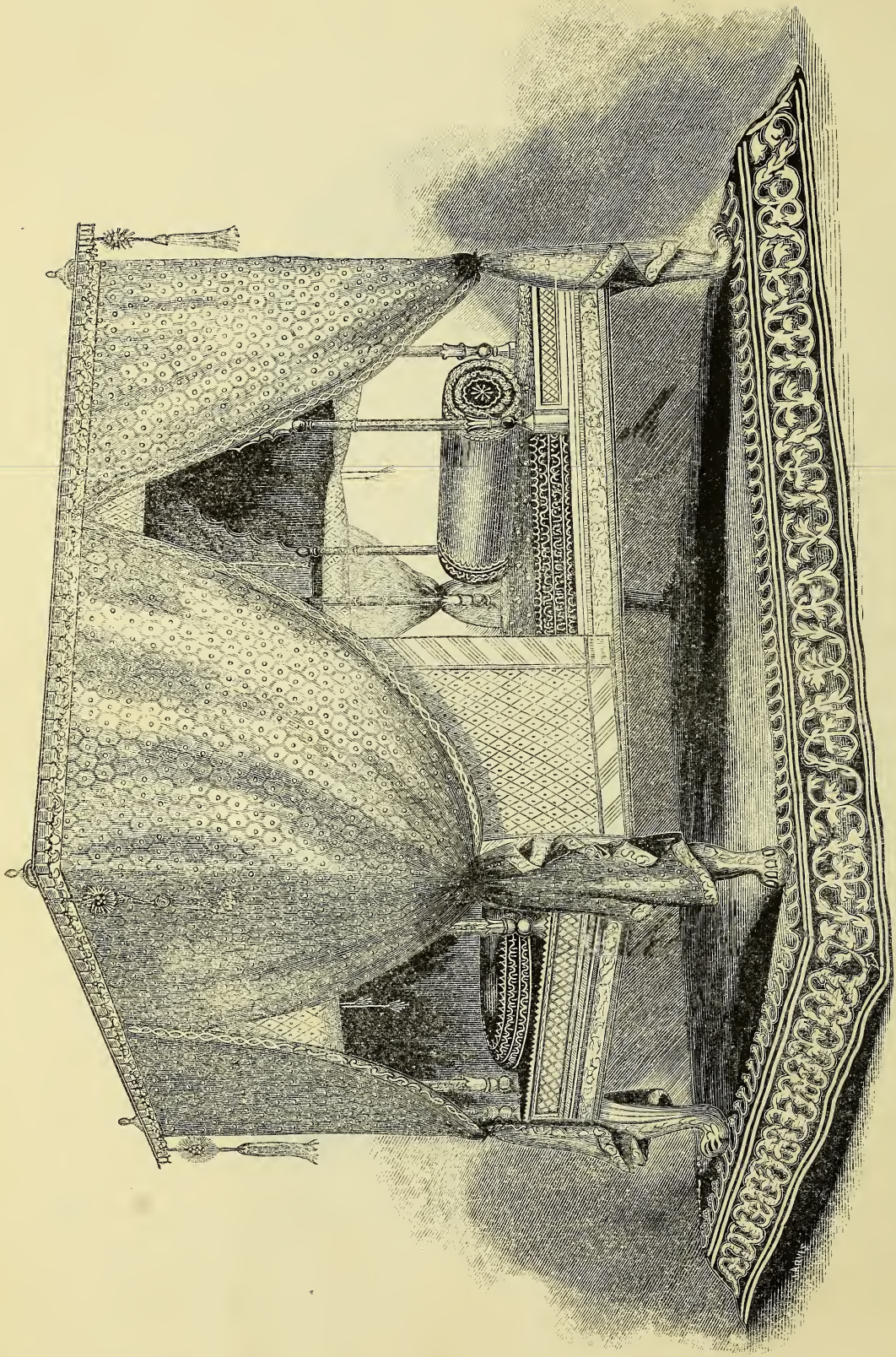

INDIAN ROYAL BEDSTEAD, EXHIBITED BY BAHOO DEENARAIN SING, BENARES, INDIA.



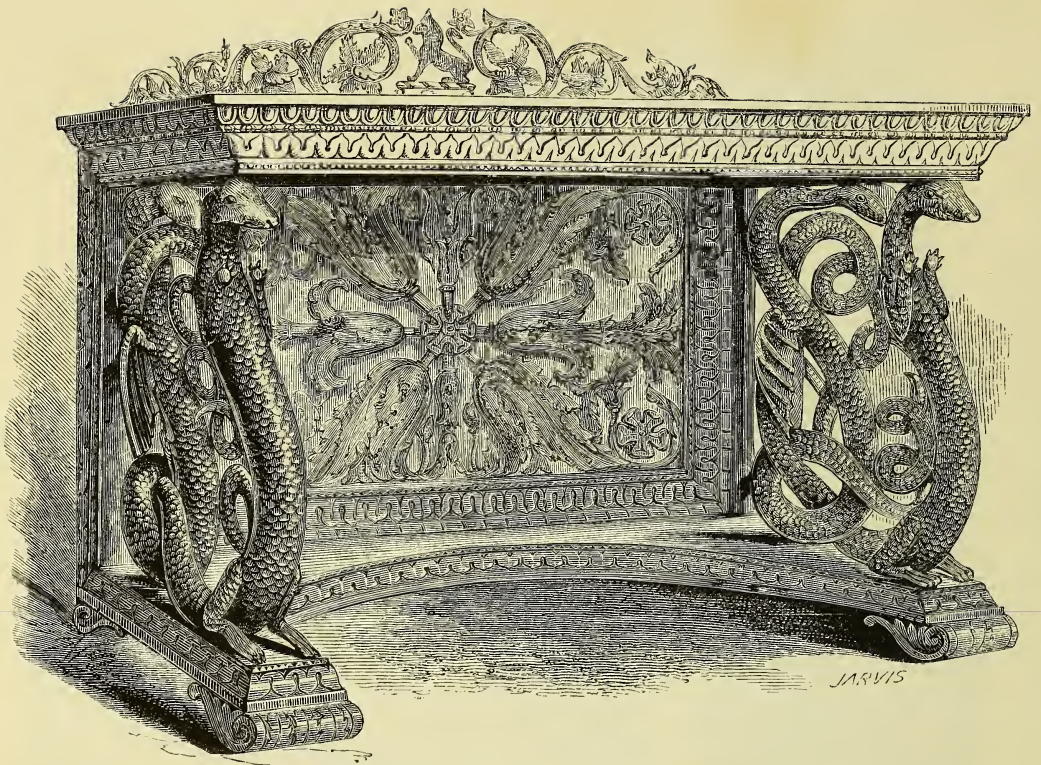

SIDEBOARD, OF NATIVE DESIGN AND CARVING. INDIA.

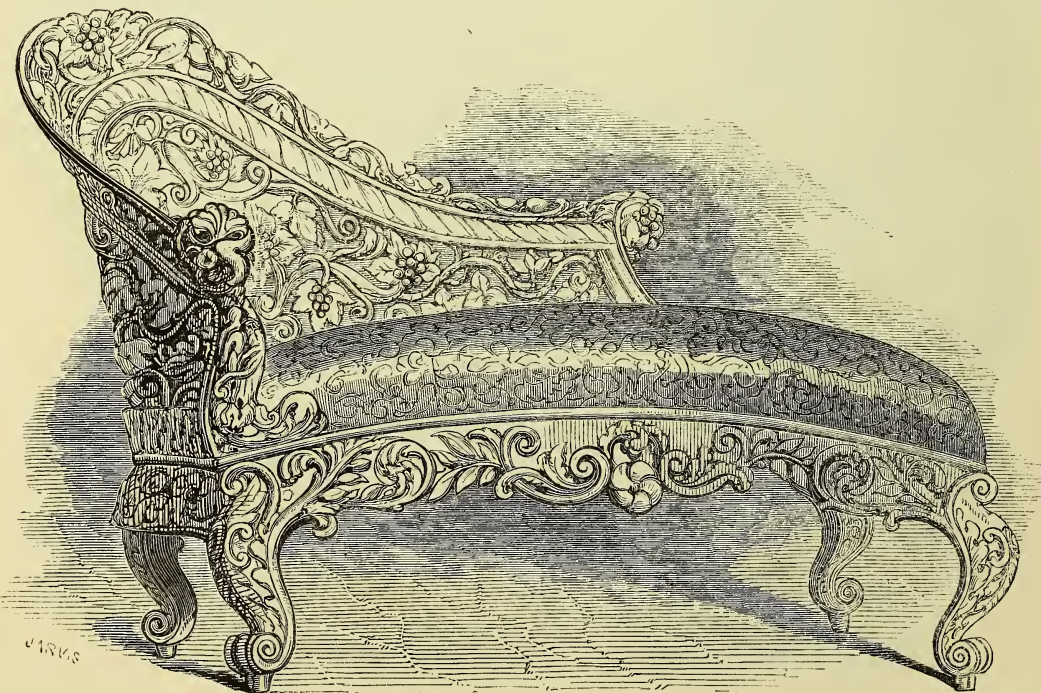

SOFA, OF NATIVE DESIGN AND EXECUTION. INDIA.







diamond, and as the rough stones are usually taken to give but one-half of their weight when cut and polished, it would allow 138½ carats, or a weight between the Pitt (or Regent) diamond (136½ carats), and that of the Grand Duke of Tuseany (139 carats), for it in its present condition; and if we take it that one-eighth of what it would be when polished was taken off with the splinter sold to the native, as related by Captain Fitzgerald, we shall then have 155½ carats for the possible weight of it, if it had been cut and polished entire; which would then place it as to weight between the Tusean and the great Russian diamond of 195 carats, which last is well known to be an Indian stone.\*

"We are not informed if this stone is considered as likely to be one of pure water, which can only be ascertained by polishing it, though we know that the natives of India, and particularly of the Deccan, are too good judges of diamonds to mistake a topaz for one, and it is stated that 70,000 rupees have been paid for the fragment. It therefore certainly adds one extraordinary fact more to the history of this most wonderful of the gems."

#### CLASS XXIV.

Glass: plain goblets, mug, glass cup, tumblers, hydraulic toy, large phial, and pickle pot, from Mirzapore in the Benares division.

Glass bangles and glass globes silvered inside. Delhi.

#### CLASS XXV.—*Ceramic Manufactures.*

Jars of glazed pottery, from Jessore.

Assortment of Pegu jars, as used in the H. C.'s Dispensary at Calcutta.

Two large Pegu jars, from Moulmein.

Specimens of glazed pottery, such as used in the H. C.'s Dispensary since 1841, when they were first introduced by the then officiating head of the department, for packing medicines free from acid or corrosive properties.

Drinking cups, with covers; tumblers, with handles; vessels for sprinkling rosewater and distributing pan; cups; hookah, called ever fresh; large hookah, for placing on the ground; specimens of earth from which the above are manufactured.—Manufactured at Amroha, district of Moradabad, in Rohilkund.

Complete assortment of native pottery for domestic purposes, as used in Calcutta.

Bread pot; dessert plate; goblet, red and white, worked; a cup, with top, and saucer; mug; different sorts of hookahs; flower pot; spittoon; rosewater pot; tea pot—from Mirzapore, division Benares.

Ghurrahs, Lookdar, manufactured at Mirzapore.

Specimens of painted pottery, from Kotah.

Specimens of Bhagulpore pottery.

Specimens of Sewan pottery. Patna.

Sorahes, large and small; metredars; hookahs; abgurrahs; gullasses; galrees; abgurrahs; ehillums; purposes—from Azimgurh.

Pieces of earthenware, from Lahore.

Earthen goblet painted in gold and flowers at Hyderabad. Major Moore.

Improved pottery from Madras, made by natives under the superintendence of Dr. Hunter.

Pottery (Ahmedabad, two boxes). This arrived just in time to be shipped, and was not examined by the Bombay Committee, while the pottery from Ahmednuggar arrived too late to be shipped.

#### CLASS XXVI.—*Furniture and Upholstery.*

Royal bedstead, with silk and velvet covering, and velvet mattress for the same, from Deo Naryn Sing of Benares.

Bedstead of silver enamelled, with Cashmere shawl hangings, complete, with pillows, &c., from Maha Rajah Goolab Sing of Cashmere.

Ottocoh, or curtains for beds, and door ehicks. Bambooreed ehairs. Ratan morahs. Large palmyra and other fans. Sittul puttee mats, very fine. (See also Class XXIX.)

Papier-maché inkstand with tray, from Cashmere and Bejnour, near Rohilkund.

A slab of alabaster from Nineveh formed into a table, by J. Pulman, at the India House, exhibited by Lieut.-Col. Sykes.

Ivory chairs, presented by the Rajah of Vizianagram.

Blackwood carved eouehes, whole and half backed, with springs and yellow silk damask; blackwood eliffonnière, bookeases, prie-dieu ehairs, with spring eushions and damask silk, large size flower stands, handsome pier tables, and side stands; sandal-wood and ebony-wood work stands, with Bombay inlaid top; work-table; chess-table—from Bombay.

Bombay furniture. The blackwood of which this is made comes from the western part of India; the damask silk from England. Among the pieces will be found two work-stands, the tops of which are of Bombay inlaid work, one with sandal-wood, the other with ebony stands. Blackwood is yielded by *Dalbergia latifolia*.

Oetagon and square marble chess-table, inlaid with agates at Agra. The carved ebony stands by Messrs. Sherwood, of Calcutta.

A square marble chess-board painted in imitation of inlaid work. W. H. Tyler, Esq.

Two screens, carved in ebony, by Moargapa Achary, a native carpenter of Madras, without any European assistance.—Exhibited by Mrs. B. Key.

Candelabra and bookease; work-table and tea-caddy. Exhibited by D. Pugh, Esq., Madras.

Two marble eouehes and ehairs, of Rajpootana marble, with open lattice-worked baeks and sides. Presented by Rajah Anund Nath Roy of Nattore.

A flower-stand carved in ebony. Exhibited by the Rev. W. Antrobus, Aetou.

#### CLASS XXVII.—*Manufactures in Mineral Substances.*

Numerous cornelian ornaments in agate, &c., from Ahmedabad.

Polished variegated marble specimens, from Ajmere and Assam.

Lattice-work in black and white marble, from Boondee. Two smaller from Ulwar.

Two lattice-work screens, carved in stone, from Mirzapore.

Sculptured figures in Rajpootana marble, from Jeypore.

Plates and cups of Jesselmere breeciated and variegated green marbles, from the Rajah of Jesselmere.

Stone plates and cups, pan, dish, and inkstand, from Monghir.

Stone cups and trays, from Patna.

Numerous specimens of cups, bottles, floating swans, and fish, from the Rajah of Jodhpore.

Marble ornaments and beads, from Boondee.

Stone figures, from Jeypore.

Stone knife handles, from the Rajah of Ulwar.

Cornelian knife handles cut by natives in Calcutta.

Marble inlaid inkstands, eard trays, paper weights, and paper knives, from Agra.

Mosaics and inlaid works:—Chessboards, inlaid with agates. Marble painted in imitation of mosaic work. Marble inkstands and paper knives inlaid. Card trays. Paper presses. The inlaid marble work is only done at Agra in the north-western provinces of Bengal.

A chessboard, and marble paper presses, painted in imitation of mosaic work.

Set of agate and cornelian chessmen, exhibited by Lieut.-Colonel Sykes.

Screens carved in stone and Rajpootana marble by natives.

\* The Koh-i-Noor, uncut, weighed 800 carats, but by cutting was reduced to 279 carats. Its value is perhaps two millions sterling.

CLASS XXVIII.—*Manufactures from Animal or Vegetable Substances, not being woven, felled, or included in other sections.*

*Manufactures from Gutta Percha.*

Splints, from Singapore:—Gutta percha splints, for setting broken limbs.

Manufactures from caoutchouc. (See Class IV.)

*Manufactures from Ivory, Horn, Shell, Cocoa-nut, and Pith.*

Articles cut out of ivory, from Berhampore:—Set of chessmen, carved from the drawings in Layard's Nineveh; elephants with umbaree, charjama, howdah, guddee, and plain; small elephant with umbaree; elephant's head; Brahminy bull and cow; camel with saddle-cloth; camel, plain; tiger; procession of a native prince; state-barge; carriage called "ekka;" cart; native dance; puzzles of various sorts, and cups and balls; one hundred set of coloured and plain letters; carved box; set of ivory workmen; the Juggodhatree; Juggernaut car; doorgah; kali; group of prisoners; ten single figures:—water-carrier, five beggars, old Brahmin, musician, fisherman, and Mahomedan. A scratcher; ivory box; silk-winders; bullock-cart; walking-stick.

Burmese carved chessmen.

Inkstand; work-boxes; two trays and stands, with scissors, knife, pen, and folder; two pen trays, with knife, scissors, pen, and folder; a whisk; letter-holder; large and small pincushions; egg-cups; ivory mortar; snuff-boxes; fan; looking-glass and case—from Lahore.

Ivory elephant; ivory horses; ivory camelopard; bison-horn lizard; ivory images of Kistna; very small ivory elephant; very minute ivory elephant, from Travancore.

Shell of a pea containing an ivory elephant, from Calicut.

Ivory bracelets. These, which are much worn by the women of Cutch and Gujerat, are made out of ivory brought from Africa.

An ivory walking-stick with gold ring, manufactured in the dominions of H. H. the Maharajah of Jodhpore.

Scratcher and combs of ivory.

Cribbage-board, made of ivory and sandal-wood, manufactured in Calcutta.

Ladies' ivory flowered work-box, an ivory fan, a knife, and chopsticks.—From the Rajah of Nepaul.

An ivory chowrie, manufactured in the dominions of H. H. the Maharajah of Jodhpore.

An ivory chowrie, manufactured in the vicinity of Bhurtpoor.

Combs, carved in ivory, from the district of Bijnour, Rohilcund.

Horn ornaments. These are made at Vizadroog, on the Concan coast of the Bombay Presidency. Horns polished. Cheroot cases and powder boxes. Pedestals for ornaments. Drinking vessel. Dogs. Trays supported by tigers and bulls. Image of Gurrood, a servant of the Hindoo god Vishnu.

Set of ornaments, made of horn, consisting of chain, cross, girdle, bracelet and earrings, manufactured at Monghyr.

Shell bracelets; chank shell entire, cut, and partially cut; half-moon saw for cutting the shells, and complete set of apparatus used by the bracelet-makers of Dacca. Exhibited by Dr. Wise and R. H. Mytton, Esq.

Cocoa-nut shell small elephant.

Small polished cocoa-nut snuff-box; bilva-fruit snuff-box.

Pair of pith figures, Rajah and Rane of Tanjore, carved out of the pith-like stem of *Æschynomone aspera*, from Trichinopoly.

Hats; bottle-covers; glass-covers; life-preservers—made from the pith-like stem of *Æschynomone aspera*.

Toys of *Hedysarum lagenarium*, now *Æschynomone aspera*. Calcutta.

See models of temples in pith, Class XXX.

A set of ebony ornaments, consisting of a chain, cross,

girdle, bracelet, and earrings. A set ditto lacquered. A set ditto of ebony—made in the district of Monghyr.

Carved cocoa-nut shells, silver mounted, black; and without silver mounting, black and brown, from Travancore.

*Manufactures from Wood, not being Furniture, Basket-work, Mats, &c.*

Woods engraved at School of Arts, Madras.

Cuscus-baskets. These are from Poona, and are made of the root of the *Andropogon muricatum*, and ornamented with tinsel, and the elytra of a species of beetle.

Gourd snuff-boxes. The kind used in Sindh and the countries to the northward: they were prepared and ornamented at Kurrachee.

Flower-holder, pandan, fan, dish-cover, fan for winnowing grain, baskets, lightholder, peacock toy, made of bamboo reed in the division of Moorshedabad.

Baskets of sorts, made of split Calamus rotang in Calcutta.

Baskets made at Monghyr.

Basket ornamented with cowries. Sheekas, or ropes for suspending pots, &c.

Mats made from the date and palm trees, Bengal.

Table mats made at Calcutta of *Phrynium dichotomum*.

Sectul pattee and musnud mats, from Midnapore.

Large and small floor mats, from Calcutta.

White and coloured mats, from district of Patna.

Cochin mats of different patterns.

Palghat mats, of different patterns, from South Malabar.

Straw mats and reed mat, Calicut.

Ratan mat, manufactured at Calcutta of *Calamus rotang*.

Bugis mats, Celebes. Rattan mat, Borneo (Banjar (Massin). Mat, Borneo Proper—sent from Singapore.

Mats, from Malay Peninsula (Pulo Aor), Philippine Islands, Pulo Siantan (Anambas Ids), Malacca, made of Bankuang or mat material.

Small articles, Malacca, Bankuang.

Nest of nine baskets, Bawian, ditto.

Covers for provisions, &c., Borneo, Banjar, Massin, made of palm leaf.

Conical hats, from Palembang and Singapore.

Specimen of basket-work, Bawian.

Set of baskets, Singapore.

Bamboo fans, Bawian.

Kopia or Mussulman cap, Malacca basket-work.

A large basket, and several of straw from Calcutta.

White and coloured mats from the district of Patna.

Specimens of plaited straw from ditto.

A large straw basket and 7 smaller, Calcutta.

XXIX.—MISCELLANEOUS MANUFACTURES.

(A.) *Soap, Candles, Ink, &c.*

Bengal native soap.

Marine soap, made of cocoa-nut oil and soda.

Marine soap, made of cocoa-nut oil and soda, from Calicut.

Sealing-wax—red, green, gold-coloured, yellow, and black, from Madras.

Sealing-wax of different colours in sticks, from Guntoor.

Sealing-wax. This is made in the southern Mahratta country at Gokak.

Stearine candles, from Bengal.—Messrs. Sainte of Cosapore.

Full-sized 9-inch and 6-inch camphorated wax candles—*from Patna.*

Red cotton for ink, and bottle of red ink, from Madras.

Bottles of Bengal ink.

(B.) *Articles for Personal use, as Writing-desks, Work-boxes, &c., in Ivory, Horn, Porcupine-quill, Sandal-wood.*

Ivory and sandal-wood writing-desk and envelope-case; sandal-wood box; small ivory box lined with sandal-

wood; ivory inkstand; buffalo-horn and ivory writing-boxes, lined inside with sandal-wood; buffalo-horn cribbage-board; ivory work-box lined with sandal-wood; porcupine-quill box lined with sandal-wood; ivory watch-stand, with work; cornelian knife-handles; ivory and sandal-wood cribbage-boards; ivory card-cases with book; paper knives; ivory combs; ivory dice. Calcutta.

Box made of cloves. Calcutta.

Ivory backgammon-board, fluted envelope-case, and knitting-box; sandal-wood and ivory box; porcupine-quill-box; white and black elk-horn inkstands; porcupine-quill, ivory, and buffalo-horn work-box; white elk-horn box; buffalo-horn box and tea-chest; sandal-wood and ivory basket—from Vizagapatam.

Porcupine-quill baskets; box made of bison-horn, containing chains made of lac, from Vizagapatam.

Inkstand of buffalo-horn set with porcupine quills, and sandal-wood drawers; watch-stand of buffalo-horn and sandal-wood; hookah snakes with pipe-sticks; hookah pipes.

Porcupine pen-holders, from Vizianagrum.

Inkstand of carved ebony; combs of carved ivory—from Bijnour, in Rohilkund.

Sandal-wood box, from Mangalore.

Backgammon-board chessmen, manufactured at Surat.

Carved box (Cutch). This is a specimen of Cutch carving. The wood is from Africa.

Bombay inlaid work. The ivory of which this is principally made is brought from Africa.

Portfolio, netting-box, basket, needle-case, envelope-case, pen-stand, paper-stand, large box, and inkstand.

Round box, turned. This is not lacquered, but polished; it is made of kao-wood.

Wooden boxes turned, and lacquered with various colours, chiefly at Hyderabad, in Sindh.

Wooden combs, from Sindh. These are made of kao wood, a species of olive from Beloochistan.

Sandal-wood box carved, sandal-wood box plain—made at Calcutta.

Inkstand, made of carved ebony, manufactured at Bijnour in the Division of Rohilkund.

A lacquered box, made at Bareilly in Rohilkund.

Sandal-wood box, and box made of Sissoo-wood—made at Nepal, and contributed by the Rajah of Nepal.

An assortment of Burmah boxes, from the Tenasserim Provinces.

Shan lacquered boxes—Mr. W. Norris.

Siri boxes, Sumatra Palembang—previous to undergoing the process of lacquering, lacquered plain, and flowered and completed.

Siri boxes, of Kayu Buka—previous to being lacquered, and lacquered and completed.

Writing box, Sumatra Palembang.

Pyramidal boxes, and small lacquered boxes, Sumatra Palembang.

Lacquered water dippers, Sumatra Palembang.

Salver or tray, Singapore, formed in the jungle by Malay woodmen, who bring them into town for sale as soon as a sufficient number is collected. Cost 5*d.* each.

Salver or sweetmeat trays, Sumatra Palembang—as cut from the forest-tree previous to being smoothed and lacquered, partly lacquered, and completed.

Covers for dishes, Borneo (interior of Banjarmasin, S. C.) The ornamental work closely resembles that of the natives of Ceram, but the shell-work is not so fine.

Set of boxes, fitting one within the other, Borneo (Kota Ringin or Waringin, S. C.)

Lid of a box, made at Ceram, in the Malacca islands. This manufacture has recently excited a certain degree of interest, from the close resemblance it bears to the ornamental works of the North American Indians.

Set of Ceram boxes.

Cigar-case, from the Celebes, manufactured from Pandanus leaf by natives of the interior.

Kopia, or skull-cap, from the Celebes. Pandanus leaf, worn by the Mussulman inhabitants.

Chess-board, from Pinang, inlaid with specimens of ornamental woods.

Bugis Kapok, from Celebes.

Clove model, Amboyna. Model of an orang baai, or state barge, made of cloves by natives of Amboyna. Flower-basket, made of cloves by natives of Amboyna. Imitation tea service, made of cloves by natives of Amboyna, presented by Robert Bain, Esq.

#### (C.) Imitation Fruits and Flowers.

Artificial fruits and vegetables. These were manufactured at Gokak, in the Belgaum Collectorate, southern Mahratta country: they are only made to order, and do not form an article of export.

1. Custard apples (*Annona squamosa*). 2. Pompalmose (*Citrus decumana*). 3. Jack fruits (*Artocarpus*). 4. Pine apples (*Bromelia ananas*). 5. Pomegranates (*Punica granatum*). 6. Ramphuls or custard apples (large). 7. Citrons (*Citrus medica*). 8. Figs (*Ficus carica*). 9. Mangoes (*Mangifera indica*). 10. Plantains (*Musa sapientum*). 11. Oranges (*Citrus aurantium*). 12. Limes (*Citrus limetta*). 13. Guavas (*Psidium pyrifera*). 14. Jambool (*Eugenia jambolana*). 15. Wood apples (*Feronia elephantum*). 16. Water melons (*Cucumis citrullus*). 17. Sugar-cane sticks (*Saccharum officinarum*). 18. Bere berries (*Zizyphus jujuba*). 19. Tamarinds (*Tamarindus*). 20. Pumpkins (*Cucurbita*). 21. Snake-gourds (*Cucumis sp.*). 22. Tooraces (*Cucumis sp.*). 23. Seoga-peds. 24. Kuraslas. 25. Bhendees (*Hibiscus longifolius*). 26. Cucumbers (*Cucumis*). 27. Brinjals (*Solanum melongena*). 28. Onions with leaves (*Allium cepa*). 29. Sweet potatoes (*Batatas edulis*). 30. Chillies, foreign (*Capsicum*). 31. Chillies, country.

Imitation fruits and flowers.—Lotus flowers, water-lilies, white and pink; parakai; peechengai; ripe and green chillies; padralengai; cadju fruits; panechakai; bilimbee; brinjals, round and long; betel-nuts, ripe; pomegranate fruits; rose-apples; codumbooly fruits; country gooseberries; chollum bunches; bandicays; Jack-fruit in miniature; pine-apple; mangoes; green and ripe plantain; Guava fruit; Guava green—from Travancore.

Lotus flower, made of sandal-wood, from Calicut.

Imitation fruits.—Walnuts, and pieces of the kernel; almonds and kernels; dates, pistachios; betel-nuts in their prepared state—from Nawab of Rampore, in Rohilkund.

#### (D.) Toys, Beads, Puzzles.

Specimens of toys in ivory, contributed by the Rajah of Jodhpore.

Toys in common use in Bengal.

Merry-go-round, from Bengal.

Toys in wood (Surat); but when they reached the committee, were found to be of so inferior a kind that they were re-sold.

Malay puzzles. Two Malay puzzles in bottles.

Strings of Brahmins' beads, made of the seeds of *Eleocarpus ganitrus*, from Bengal.

Necklaces and bracelets. These are made at Poona, and stated to be composed of the dust of sandal-wood mixed with gum.

Beads (Gujerath). See Class I.

#### Games.

Boxes of gungalah or packs of cards.

Chowpan board, contributed by the Rajah of Jodhpore.

#### Lac Ware.

Lac ware.—Goblet, varnished; large and small pots; a kind of mug. Wood ware.—Bottle pot; large and small cups; small water-pot; pot for vermilion; plates and toys—from Mirzapore.

Lacquered toys, and lac ornaments.

Specimens of sand with which lac grindstones are made; corundum stones, which, being pulverized, are used in making lac grindstones; lac grindstone complete—from Coimbatore.

Ornaments from dried fruits of cocoa-nut, meant to represent the garlands given to visitors of distinction on visits to the palace, worn by ladies at a particular festival—from Tanjore.

Doyleys made by the ladies of the feudal Mahratta family of Angria, reduced to dependence on their industry by political changes, and chiefly through the suppression of piracy on the western coast of India.—J. Chapman, Esq.

(G.) *Fans, Umbrellas, Parasols, Chowrees, and Walking-sticks.*

Fan with gold handle, khus khus-ka punkah, made of khus-khus grass (*Andropogon muricatem*), which, when wetted, emits a fine fragrance.—Contributed by H. H. the Rajah of Kota.

Sandal-wood fans.

Large and hand-fans of Palmyra leaf.—Bengal.

A fan from the Rajah of Pattiala.

A large and two small fans with plated handle, from Calcutta.

Fans from the states of the Rajah of Jodhpore.

A state fan, with silver handle, from Moorshedabad.

Fan of China beads and pearls.—Delhi.

State umbrella, with silver stick, from Moorshedabad.

(See accompanying Plate.)

An ornamented and gold embroidered state parasol with silver stick—from Moorshedabad.

Assortment of Bengalee chhattahs, used by natives during rainy season.

Soorooj mooke, a native parasol, with silver top and handle. Gold umbrella, with silver top and handle.—Contributed by the Rajah of Dholepore.

Assamese umbrellas, used by nobility; cane fans; cane mat, for noblemen to sit on; peacock-feather fans, used by natives of rank; luggage baskets, used for carrying cloths.—Assam.

An umbrella made of painted cloth. A small umbrella.—Manufactured at Calcutta.

Four bamboo walking-sticks, gold and silver mounted, contributed by the Rajah of Ulwar.

A painted stick with silver top, contributed by the Rajah of Kissenghur.

Walking-sticks of sorts, made at Calcutta and Cochin.

Betel-nut sticks.

Sandal-wood whisk, from Calicut.

Sandal-wood and ivory chowrees, or whisks, from the Rajah of Bhurtpore.

Two chowrees, of the tail of the Yak (*Bos grunniens*), with silver handles—from the Rajah of Ulwar.

*Hookahs and Hookah Snakes.*

Cocoa-nut and lac hookahs—from Bengal

Hookah snake with nicha; snake-cover for the hookah, with a rosette to fasten to the mouth-piece; hookah snakes, with pipe-sticks; hookah pipe, stick, &c.

Selim for smoking, sent from Singapore.

Singpoo pipe for smoking opium; box of pipes.

*Boots and Shoes, &c.*

Shoes worked with gold and silver.

Gold-worked shoes and slippers, for females; silver-worked slippers; gold-worked shoes, for men and children; Bengalee shoes with gold and silver; Bengalee country leather; Bengalee writing red leather; Bengalee yellow; buffalo-horn combs.

Scindean boots and shoes, from H. H. Meer Ali Morad of Khyrpoor.

Looking-glass and case, from the Rancee Sookhan of Seharumpore.

(H.) *Fishing Tackle of all kinds.*

Nets—Sekaolies—made at Calcutta.

Floating net, Singapore, employed in taking a small kind of herring in the neighbouring strait. The twine is of cotton, manufactured in Java.

Floating net. The twine of this net is made from the rami fibre, *Urtica nivea*. (See Class IV.)

Casting net. The thread made in Java from native cotton.

Seine net. Twine of rami fibre.

Fishing lines. Twine of rami fibre.

Fishing lines. Twine made of Java cotton thread, tanned with the fruit of the mangrove.

*Description of Fishing in Bombay Harbour and its Vicinity.*

Model of stake-net fishing, with fishing-nets used in Bombay.

1 If new stakes are to be sunk, a space of 2 fathoms must be reserved for the passage of boats on each side of the compartment. Fishing in stakes is always within 10 fathoms of water; stakes are made of heddy wood in three or four pieces. If a cocoa-nut tree, one answers the purpose. In some cases a piece is added to it, if the tree is a short one. A stake is sunk about 3 fathoms in mud; it is generally 15 fathoms long, 3 of which are buried in the mud, 10 in water, and about 2 over the surface. On the occasion of sinking a stake, two boats are put together and anchored fore and aft, with anchors of about 2 cwt. each, leaving a space of about a quarter fathom between the two, and two cross beams are tied over the boats, in order that they may remain firm and close together, and hold the stake between the reserved space, the lower end of which (the stake) is let down, tied up with large and heavy stones, or anchors of a large size. In order to sink it below they tie four ropes at the top of the stake, each of about 2 or 2½ inches; these ropes are fastened to the masts of the boats with blocks, and some of the people in the boats (who are generally between 30 and 40) pull the stake down by standing over the fore parts of the boats, and let it into the water in a straight line with the others, through the space allotted for that purpose, when it is sunk in the manner above represented. This operation is performed when there is full tide; and as the stake is held between the two boats, tied up with the ropes above alluded to, it is driven down by the force of the boats, which sink also as much as the water; so soon as the ropes become slack they are made fast over and over.

2 The bark of the tree (Babal bark), used in giving colour to the net, accompanies this bearing, and even number (No. 2). A new net, prior to being used, must be boiled in water in copper pots, with chunam or lime, for two days and two nights, and then it may be used for three days, when it should be washed and coloured. All the nets, it may be understood, are made of twine, with the exception of the Wavree net, which is made of thread.

3 Each net, called dole net, is 22 fathoms long, 15 broad, and is made of the shape of a bag, but wide at the mouth (15 fathoms), and narrow at the end (about 2 fathoms), meshes 8 inches wide at the mouth, and reduced in proportion, so as to be half an inch wide at the end. On throwing it into the sea, the mouth on both sides is fastened to the stakes at the distance of 10 fathoms each, which is the space reserved between the stakes. Each side is fastened to a ring put on the stake, the upper edge is held up, and the lower no sooner is tied to the ring than it goes down as far as 8 fathoms, by the weight of a stone which is kept always tied up to the girth. A line across is also tied up between the two stakes, to which the upper edge of the net is tied just in the middle, in order that it may not remain loose and obstruct the entry of the fish. It may be stated that before throwing the net into the sea, its floating end is tied up and secured fast to prevent the escape of the fish. Each boat carries four or five nets, and sometimes three, but not more than five under any circumstances. On the occasion of fishing, when there is full tide, the mouth of the net is kept on the side of the harbour, in order that, on the tide receding, the fish going out may enter the net, and through the strength of the current run down to the end of the net, where all the fish join together; and *vice versa* is the case on the occasion of the ingress of the water. On pulling the net, they draw the lower end up, and after taking it on board they open the end and draw the fish



286.

ORNAMENTAL STATE UMBRELLA, WITH SILVER HANDLE. INDIA.



out. The fishing operation by the stakes commences by the 10th of the moon, and lasts until the 20th, when again by the 26th it recommences, which lasts until the 5th of the moon, thus the operation is carried on twice in a month; each day after fishing, the net is brought home, washed or dipped once or twice in salt water, and exposed to air for a little while, and taken back again for fishing. During the neap-tides, when the operation ceases, the nets are brought home, washed thoroughly in sweet water, coloured if necessary, and dried in the sun. Unless this be done, the fish would not fall in, but keep afar off, from the nets having become offensive. The meshes are wide at the mouth, and narrow at the end. The fish generally caught are mostly bomloes and prawns, large and small coorvins, pomphlets, soles, shrimps, and many other sorts of small fish, sold in Bombay Bazaar. Each stake made of wood costs 40 rupees, and if cocoa-nut tree 15 rupees; the former is durable, and can last about eight years, and the latter three or four years only. Each dole-net costs 40 rupees.

4 The stakes are generally removed from the sea in the month of May, and fixed again in the month of October, because they are subject to being broken during the south-west monsoon; but those that are fixed in the river, or inner harbour, are allowed to remain throughout the year. No implements or instruments are used, such as weapons, &c., for killing and taking the fish out of the net. They are generally taken out by bamboo baskets, large and small, such as are required and suited to the purpose, the cost of which varies from one to two annas each.

5 If in case a large fish, such as a shark or seal fish, enter a net, they devour small fish, and tear off and destroy the net. In this case it cannot be mended by others but those that are well versed in its making. If in mending a mesh is made larger or smaller than the usual proportion, it gives way soon again in the same place from straining. Thus the information relative to fishing by stakes is complete, so far as the mode generally observed by the fishermen of Worlee, Mahim, Dharawee, and Scion; but the fishermen of Bombay, who fish in 12 fathoms water, have their stakes 19 fathoms long; they are sunk in proportion to about 3 feet in mud, 12 in water, and 4 above the surface. Their net is 25 fathoms long, wide at the mouth 20 fathoms, on each side 10 fathoms, and applied in the space of 14 fathoms, which is the width or space reserved between the two stakes. Each stake is made of four pieces of wood, cost about 60 rupees, and the cost of the net is 80 rupees. Each boat carries two nets only; meshes at the mouth 12 inches wide, and at the end half an inch.

6 In dole fishing at Bombay and Sewree they generally take two nets in a boat, a nakhwa, or the owner, provides a boat with sails, oars, ropes, &c., complete, as also the stakes, together with nets, and all other implements required for the purpose of fishing; in fact, he bears all the expenses connected with it, and in return takes two-thirds of the fish obtained, the rest goes to the crew; but if coorvin, which is a large and valuable fish, all such fish goes to his share, in which the crews are not allowed to participate. If any small fish, it is divided in three; two parts of it are taken by the owner, and one by the crew.

7 Dole fishing of Worlee, Mahim, Dharawee, and Scion differs somewhat from the above in respect to distribution. They take generally four or five nets in a boat: an owner of a boat and net takes four shares, if of a net only takes two shares, and each Lascar or crew one share; all and every sort of fish obtained, whether large or small, is included in this distribution, and no exception made as in the case of Bombay dole.

8 A paul net is 60 fathoms long and 2 broad. The fish caught in this is of several kinds—bing, pomphlets white, sea-sharks, and several other small sorts of fish, with the exception of bomloes and prawns. Each boat contains ten or twelve men carrying nets at the rate of three per head; meshes 5 inches. Each net costs six rupees. This excursion is carried on from the 20th to

the 8th of the moon, from September to March, between 15 and 25 fathoms of water outside the harbour.

9 A *pass net* is 40 fathoms long and 2 broad. Each boat contains ten or twelve men, and take nets at the rate of three per head. Meshes 6 inches each. Net costs 58 rupees. The fish obtained is mostly black pomphlets, sharks, and a few white pomphlets. The mode of throwing nets is the same as that of *wagra*, described in the 10th paragraph. This fishing is carried on from the 20th to the 8th of the moon, during five months, from April to August, in 15 or 20 fathoms of water out of harbour.

10 Nets for deep-water fishing, say between 6 and 8 fathoms, are called *wagra*, each 30 fathoms in length and 2 in breadth. It is let go straight down below in the water, tied up with a buoy-rope. The fish obtained in this excursion is large [*shir fish*], salmon-fish, coorvin, &c. The price of this net is six rupees; the size of mesh is 7 inches. They pull the net into the boat, and draw the fish out. This fishing is only during the full tide. Each boat takes six or seven men, and the nets are taken at the rate of three per head. Each net has a stick interwoven in it at the distance of  $1\frac{1}{2}$  fathoms, and at the end a stone is tied, in order to sink it below. On the occasion of throwing the nets into the sea they unsail the boat, and tie each net with the other, and throw them down altogether, by fastening one end to the boat. This fishing is carried on generally throughout the year, and obtains generally no other fish but *dadah*, and sometimes salmon-fish.—(*Shir Mahi*.)

11 A *rauvas*, or salmon-net, is 20 fathoms long and  $1\frac{1}{2}$  broad. One boat, containing six men, takes from 20 to 25 nets, and sails about the harbour in the river during moonlight nights, and the fish obtained is generally salmon-fish, and seldom pomphlets. Meshes 4 inches; and the cost of the net is four rupees. Large canoes also proceed on this excursion within the river. During dark nights this operation is unproductive, as the fish is not then obtainable, and therefore they proceed only in moonlight nights. It is carried on from November to March.

12 A *peia net* is 40 fathoms long and  $1\frac{1}{2}$  broad, thrown in  $\frac{3}{4}$  fathoms of water, and held by three men at each end. This excursion is daily and constantly in progress at the commencement of tide and ebb tide; and the fish obtained is of small kind, generally mullets, prawns, needle-fish, and haddy-fish. Meshes  $\frac{3}{4}$  inch; the cost is 50 rupees. This excursion is carried on throughout the year.

13 A *weddy net* is 5 fathoms long and  $2\frac{1}{2}$  broad. Two men are employed fishing, one at each end, and one attends them with a basket, or shoulder, to pick up fish and put them into the basket. The cost of each net is seven rupees; meshes  $\frac{3}{4}$  of inch. This excursion is made at any time of the day or night. The fish caught in this, as in the preceding one, called *peia net*, and the excursion is carried on throughout the year.

14 A *waua fishing*. In this excursion *peia nets* are used, as many as required to be laid on the space of ground wished to occupy for the purpose on shore, say about 100 fathoms in length. They proceed on this excursion when the water is low, and the spot nearly dry, when they lay down one end of the net over the ground in a circuitous manner, and fix sticks about 2 fathoms long over it, at a certain distance from each other, and apply mud to that part spread on the ground, to prevent its floating up and set the upper part loose. On the tide being full they go to the spot in a canoe, lift up the other part set loose, and fasten it to the sticks, with which they make a circuitous wall of the net all round on three sides in the water (the fourth a back), say about  $1\frac{1}{2}$  fathoms in height, to prevent the return or escape of the fish which has gone towards shore on the ebb tide setting in, and thus the fish that have run down are secured in the space surrounded; and on the water being low, they catch the fish by hand, and put them into the baskets they carry about. In this excursion much fish is caught of different descriptions, and particularly when there is mud mullet; but it can be effected only during spring-tides



twice in each month, say about four days during each spring. Cray-fish, prawns large and small, claps, needle-fish, haddy-fish, &c., are obtained.

15 A wavree net is 10 fathoms long and 1 broad. The fish caught in this are small mullet and haddy-fish within the harbour; meshes 1 inch. They proceed in a canoe made of a single timber, which takes three men and eight or ten nets. The cost is five rupees per net. This fishing is carried on in the months of November, December, January, and February, during moon-light, on the spring-tide, in three or four fathoms of water.

16 A paug net (carp-net) is of the shape of a bugle,  $1\frac{1}{2}$  fathoms long, and 3 feet in circumference at the mouth, and narrow at the end, where it is completely closed. At its mouth small pieces of lead plate are interwoven at the distance of 2 inches, in order to make it weighty, so as to go deep. It is thrown in a peculiar way: a man holds it on his elbow, and throws it (by spreading its mouth) into the water, tying the end with a thin rope to the wrist of his left hand. The fish obtained is wekroo, shingalah, khuffoora, mullet, craid-fish, &c.; but the quantity obtained is always small. Meshes 1 inch; the cost of each net is five rupees. This excursion is in about  $\frac{3}{4}$  fathoms, at any time of the day or night, and continued throughout the year.

17 Hook-fishing is within 3 fathoms, either in the river or in open sea. It is made by a line about 50 fathoms long. A hook, tied to a piece of twine about a foot long, is fastened to the line at the distance of a fathom, and thus one line contains 50 hooks; a prawn, or any other small fish, is applied to each hook. Two or three men proceed in a canoe: to one end of the line a large piece of wood is tied to keep the line floating, which they throw in the water, and fasten the other end to the boat. The fish obtained are generally large, and of the description called shingalah, wave, wekroo, samb, skate, and shark. The cost of the line, with hooks, &c., complete, is three rupees. This fishing is called "khauda."

18 Dorlee, or hook-fishing, is also in 3 fathoms water, either in river or sea, by a line about 25 fathoms long, with hooks tied at the distance of about  $\frac{1}{2}$  fathom each, at the end of the line. Thus one line does not contain more than three or four hooks: a prawn, or any other small fish, is applied to each hook, and the rest of the line is reserved for holding on, and setting loose in the sea as much as the fish may struggle and run along with it. This line has a ball of lead at one end, by the weight of which it goes immediately to the bottom. One man goes in a canoe on this excursion, and the fish obtained is shingalah, wekroo, dhomee, samb, and seldom small salmon-fish. The cost of the line, with hooks, &c., complete, is 8 annas.

19 The mode of fishing in the adjacent salt-water inlets, such as Penn River, Nagotua, Pauwell, Ooruu, Carauja, &c., is mostly by "waua," the description of which is given in paragraph 14.

20 There are no pots made for keeping the fish; but the fish are generally put and kept in baskets made of bamboo; each basket carries a weight of about  $1\frac{1}{2}$  maund, and if a larger basket, 3 maunds. The fish is conveyed generally on the head, by women belonging to the fishermen. A man carries fish, if larger quantity, in two baskets on a sling. The baskets used are both large and small, according to the size and quantity of fish they may have to convey.

21 In daldee fishing, they make use of paul, pass, wagra, and ravauss nets. Those of Mahim and Worley have a particular way of distributing proceeds amongst their crews. Each man takes three nets, and all such nets as are taken in a boat are tied together with each other and thrown into the sea. Any fish obtained in such three nets belonging to one man is taken by him alone: his comrades are not allowed to share in it. Every man has his special marks to his nets, by which they are distinguished and recognised. In fact, the owner of such net as may catch fish will be benefited alone, and no others. The owner of the boat is remunerated with fish, at the rate of 4 to a cargo of 21.

22 With the daldee fishing of Bombay harbour the case is the reverse of the above. They distribute the prize equally amongst them all, without any exception whatever, whether the nets of all be productive or not; and the owner of the boat is remunerated with fish, at the rate of 5 to a cargo of 21.

23 Bomloes are dried at several places in the vicinity of Bombay, and cured with salt. The quantity of fish is estimated to be annually as follows:—

|                                         |          |
|-----------------------------------------|----------|
| At Worlee, about . . . . .              | 20 lacs. |
| At Mahim, Dharawee, and Scion . . . . . | 20 „     |

#### CLASS XXX.

##### FINE ARTS, AS FAR AS THEY COME WITHIN THE LIMITS OF THE EXHIBITION.

###### (A.) *Sculpture and Models of Figures.*

Clay figures, manufactured in Kishnaghur, and representing the various castes and professions of the Hindoos, viz. :—Sheristadar or head native officer of a court of justice; sirdar-bearer or valet; chaprassee or messenger; bhistee or water-carrier; brojobassee or armed watchman; sircar or account-keeper; dak-runner or man who carries the Government mail; abdar or man who cools the water; cart with bullocks; natives of Bengal making sugar; khamar or Bengal blacksmith; bhiri-wallah or native shepherd; sawyers; prisoner; khansamah or butler; kitmutgar or table-servant; mahter or sweeper; ayah or maid-servant; woman of Bengal carrying water; Bengal fisherman; Chinaman resident in Calcutta; hookah burdar; women cleaning rice; Bengal shopkeeper weighing rice; Bengal musician playing on the trumpet; Bengal weaver preparing the thread; Bengal milkman; sweetmeat baker; Bengal conveyance for women; wood-hoo bahoo or a Hindoo religious mendicant; Bengal musician; massaljee or link-bearer; baberchee or cook; durzee or tailor; syce or groom; dhai or nurse; dhobie or washerman; shopuriah or snake-charmer; woman of Bengal spinning; woman of Bengal cleaning cotton; old Brahmin at his devotions; pundit or learned Hindoo; Bengal netmaker; Indian barber; mallee or gardener; husbandman; soonar or goldsmith; ploughing; harrowing; women grinding rice; chumar or shoemaker; musician playing on the fiddle; Bengal potter; chowkeedar or village watchman; Bengal musicians playing on the drum and cymbals; Bengal singer; Bengal woman carrying a child; Bengal baker; mistree or carpenter; man preparing cotton; coolee or Bengal porter; dawkbanghy-burdar or man who carries the post-office parcels; fukeer or Mussulman religious mendicant; old Brahmin.

Models of natives of different castes. These are manufactured at Gokak, in the Belgaum Collectorate, and Southern Mahratta country. They are only made to order, and do not form an article of export.

Lohar or blacksmith; pooraneeh; Hindoo pattawallah; weaver; dhobie or washerman; well and people washing; buffaloe; Bengal bheestee or water-carrier; mohar; Mussulman woman; carpenter; bheestee and bullock; cotton printer; cheeta or hunting leopard and cart; palanquin with bearers; potter; sepoy; shetsundee; byragee Wychnew; byrager shir; woman grinding; byragee with dog; Brahmin sirdar; Mahratta sirdar; coombee and bullock; suwar or horseman; elephant; potter with wheel; tailor or durzee; carcom; sepoy mahratttee; Brahmin; Brahmin wife and child; Mussulman sepoy; nurse with child; banian; jungum; Moosulman; brinjaree.

Model of a Jamma Bundi. Collector making the annual jambundi, Dharwar. Every caste in the Dukkun, together with tents, trees, &c. This was made in plaster at Poona, and is presented for exhibition by Mr. Mansfield of the Civil Service.

The following is a description of it:—

"It represents the encampment of a collector whilst moving about on the annual tour through his district. His camp is pitched in a Maugee tope or grove, at a short

distance from a small village. A section of the wall or fort surrounding the village is exhibited, in the inside of which are rows of houses with shops, displaying for sale grain, and all kinds of petty merchandise. A river flows by the outside of the fort, and on the banks of it is portrayed that busy scene which is so peculiar to Indian life—men and women washing cloths, laying them out to dry, filling their pitchers with water, making their ablutions, &c. A bridge is thrown across the river, leading direct to the door of the fort. In another part are fields of standing corn, a crop of jowary, and of sugar-cane; adjoining them is a thrashing place, where the oxen are treading out the corn, and the cultivators in a contiguous spot winnowing and preparing it for market; another field is being ploughed and prepared for sowing. Next is a well with bullocks drawing water for irrigation with the leathern bucket or mot'l.

“The collector himself is seated inside the double-poled tent, and is supposed to be engaged in making the Jumma bundy, or settlement for the current year’s revenue. He is surrounded by the manletdar and the other revenue officers of the district, with a number of Carpoons seated around. A large body of ryots is collected at the door of the tent, petitioning for “soot,” or remission of part of their revenue payments. Groups of them are seated here and there round the adjoining trees, where they are having their petitions written out by the coolkurnees or village accountants. Besides the double-poled tent, there is a beehoba, or sleeping tent, and an office rowtee, and in the rear are a large lot of rowtees and palls for the use of the butler, cook, and other servants. The horses are picketed at a short distance off, and near them are the camels and bullock carts engaged for the transport of the tents and baggage. There are numerous other scenes descriptive of a camp life on this bustling, important occasion; but it would occupy too much space to describe them. There are altogether about 300 figures of all kinds. The tents are made of wood, with a white cloth covering pasted over them. The temples, houses, and section of the village are also cut out of wood and coloured; but all the animals and figures are of the Poonah plaster-work. The whole is exhibited on a large wooden platform nine feet square. A list of all the figures, with the numbers on them, denoting their position on the platform, has been enclosed in one of the boxes. This will serve as a sort of key for arranging the whole.”

Thirty-five figures in wood from the Rajah of Jodhpore. Figures of the principal sects, male and female, at Cochin and Travancore, exhibited by T. E. J. Boileau, Esq.

Model of European court of justice in the provinces, made by a native modeller, Jessore.

Model of a native court of justice in India.

Model of a silk factory, by Mr. Cockburn, of Moorsheadabad.

Model of an indigo factory.

Messrs. Watson’s model of a native oil mill.

Model of a farm establishment. Java, *via* Singapore.

Model of a Burmese house of the higher class.

Model of a Burmese pagoda, gilt, with images and ornaments.

Model of a priest’s house in Burma.

Images of Burmese man and woman.

Image of Godomah on his earthly throne, as king of kings.

Image of Godomah fasting for four years protected by an enormous serpent.

Image of Godomah’s last appearance on earth.

Image of Amnodal, brother to Godomah.

Model of the Churuk Pooja, a religious penance practised in Bengal.

Stone sewala or Hindoo temple, from Mirzapore.

Stone model of Hindoo temple, presented by Baboo Futtu Naryn Sing of Benares.

Model of unfinished rogyoporum or entrance to the pagoda at Streerungum; model of Nagasoorum pagoda at Combaconum, from Trichinopoly.

Model in pith of *Nuttu* or *sholah* plant (*Æschynomene aspera*), by Lieut-Colonel Burney.

Two smaller figures: Mr. Gandy.

Painted wooden tray (Khyrpoor). This was sent down among the collection of articles forwarded for the Great Exhibition by H. H. Meer Ali Morad, and has therefore been transmitted. It bears a good representation of the manner in which the ceilings of the best houses in Sindh are ornamented.

Stone intaglios:—Gunesch, Burmah, Bishen Dabee, Muchk, Kuchk, Barah, Nursing, Bawon, Pursooram, Ram Chunder, Bulram, Boudh, Kulunke, Radha Krishen, Radha of the Sun, Radha of the Moon, Ooma Musheswai, Inder Koomaree, Urjoon, Suhden, Bheemsen, Narayan, Hunooman, Indrainee, Burhmanee, Roodranee, Maha Luchmee, Bhugwatee, Kalee, Koomar, Munjoosree, Duckhen Kalee, Bulbhuder, Bhyrub, Kal Moorti Bhyrub, Mahakal, Singhnee, Bayaghurnee, Guroor, Kuwondh, Khayah, Gourse—representing the mythology of the Nepaulese, exhibited by His Highness the Rajah of Nepal.

#### *Enamelling.*

Enamelling (Cutch). This is a small knife, or dagger, watered like a Khorasan blade, which it probably is, the sheath only having been made in Cutch.

Enamelling (Sindh). This is a large knife, probably of Khorasan manufacture, with sheaths enamelled in Sindh.

Enamelling (Khyrpoor). This is another knife similar to the foregoing, sent among the collection from H. H. Meer Ali Moorad.

Gold bangles, enamelled. These form part of the collection from H. H. Meer Ali Moorad, and were not opened.

Enamelling (Indore). This is called “dasoostare,” and is manufactured at Jeypore. R. C. Hamilton, Esq.

Model of a gateway (Cutch) in silver, with toujon and bearers. This is a model of the gateway to the palace of H. H. the Rao of Cutch at Booj. It was made at Booj.

Model of a musjed. This is a specimen of one of the wooden models for which Ahmedabad is famous. It is the property of Mr. Mansfield, of the Bombay Civil Service.

Model of a chuburdee, or Hindoo cenotaph (Cutch). This is made of red wood from Africa. It is 1 foot 3½ inches long, 11½ inches broad, and 10 inches high.

Model in wood of a Hindoo temple (Cutch). This is made of sandal-wood. It is 1 foot 7 inches long, the same broad, and 1 foot 1½ inch high. Rao of Cutch.

#### *Caligraphy.*

Persian manuscripts, executed by the Caligrapher to the King of Oude.

The same, executed with the nails of the thumb and second finger of the right hand.

Two specimens of caligraphy in Persian, two ditto in Nagree, and one ditto in Persian (running hand), executed at Ulwar, in the States of Rajpootana.

A highly-ornamented manuscript, in Persian and Guzeratee, containing an address of thanks to Sir Jamsetjee Jeejeebhoy, of Bombay, on occasion of his visiting his native town of Nowsaree, near Surat, and stating in detail the works he had constructed there at his own expense for gratuitous public use. The address is signed by two thousand persons. Deposited (at the request of the committee of native gentlemen who managed the address), by Jevanjee Pestonjee and Rustomjee Viceajee, Esqrs.

#### *Drawings representing Occupations, Customs, &c.*

Drawings on talc of the servants in North-west Provinces, and of the attendants and Indian articles employed in the Mahomedan ceremony of the Mohurrum, exhibited by Mrs. Royle.

Drawings on talc of agricultural operations, trades and castes, and servants, of southern part of the Peninsula of India, exhibited by T. Boileau, Esq.

Book, containing paintings, by Buldeo.

Water-colour drawing, by a native artist at Ulwar.

Set of water-colour drawings, representing the process of the opium cultivation and manufacture at Patna.

Another set, exhibiting the process of the shell bracelet manufacture in Dacca.

A set of water-colour drawings, representing the plants which the various species of silkworms feed upon.

Another set, representing Indian athletics.

Two portraits, Nabah Rajah and his father, from the Rajah of Pattiala.

*Engravings on Gems.*

Two seals, cut in stone—Sir T. Munro's monument and the lighthouse at Madras.

Four seals, engraved by Budroodeen Alee Khan of Delhi, engraver on gems for the native Princes of India.

1. A cornelian seal. Shah in Shah Solomon Jah, Kyuan Bargah, Kuyan-oo-dihir Sooltanoobuhr Mored Ultaf-ezud Rihman Badshah Englishist o Ireland, Furman Furmac Momalike Hind, Nasir oodeen i Mussseeha Mulkih Mouzuma. *Translation.*—Victoria, the First Monarch of the World, as Solomon in magnificence, with a Court like Saturn, Empress of the Age, Sovereign of the Seas, the Source of Beneficence, by the Grace of God Queen of England and Ireland, Ruler of the Kingdoms of Hindoostan, Defender of the Faith of Christ, the Great Queen Victoria.

2. A bloodstone seal. Ul Moid bu taced e Illahee, Fukhr Khandan Shah in Shah Brunswick, Unees Mouziz Muilkih Mouzuma Shahzadah, Rufece ool Qudr wahu Shan wu Suramud Bargah i Englistan Albert Francis Augustus Charles Einanuel. *Translation.*—The distinguished by the aid of God, the noblest of the family of Brunswick, the Honoured Consort of the Great Queen, Prince, highest in rank, great in dignity, the Chief in Excellence of the English Court, Albert Francis Augustus Charles Emanuel.

3. An emerald signet seal. Badshah e Buhr or bur Adil bu taced i Khoda. Hookumran dur huft Kishwur Mulkih, *Translation.*—Victoria. Sovereign of the Sea and Land. The Just, by the favour of God, Governor of the World (or the Seven Climates).

4. An emerald signet seal. Simply the Christian names of His Royal Highness Prince Albert.

The seals and signets have been set in gold by native workmen under European superintendence in Calcutta.—*From List of Articles contributed from Bengal.*

In addition to the many articles purchased by the various Committees appointed by the Indian Governments, and enumerated at p. 858-59, the following are—

*Contributors to the Exhibition in the Bengal Presidency.*

H. M. the KING of OUDE.  
 H. H. the MAHARAJAH of NEPAL.  
 H. H. the MAHARAJAH RAO SCINDIAH of GWALIOR.  
 H. H. the MAHARAJAH of NAGPORE.  
 H. H. the MAHARAJAH of JODHPORE.  
 H. H. the RAJAH of KOTAH.  
 H. H. the RAJAH ANUND ROY of NATTORE.  
 H. H. the RAJAH of BOONDEE.  
 H. H. the RAJAH of VIJAYPORE.  
 H. H. the RAJAH of BICKANEER.  
 H. H. the RAJAH of JESSELMERE.  
 H. H. the RAJAH of DHOLEPORE.  
 H. H. the RAJAH of TONK.  
 H. H. the RAJAH of SEROHEE.  
 H. H. the RAJAH of PERTAUBGURH.  
 H. H. the RAJAH of ULWAR.  
 H. H. the RAJAH of BHURTPORE.  
 H. H. the RAJAH of KISHENGURH.  
 H. H. the RAJAH of BITEAH.  
 The NAWAB of RAMPORE.  
 SHAH KUBEER OOD DEEN, of Sasseram.  
 BABOO DEO NARAYUN, of Benares.  
 BABOO FUTTEH NARAYUN SING, of Benares.  
 BABOO RAM GOPAUL GHOSE.  
 BABOO JOY KISSEN MOOKEYEE.  
 DEO SHUNKUR SILHET.  
 DEO GOPINAUTH DEBEE PERSAUD.  
 DEO RAM PERSHAN SING.  
 DEO CHOTAO LALL GUNPUTSJEE.

DEO SOROOP CHUND DOSS, of Dacca.  
 KHAJA ALEE MOOLLEE, of Dacca.  
 MUSHUT PURSNAMGEER of MIRZAPORE.  
 BABOO KOONER SING.  
 BABOO DYAL SING.  
 BABOO RAM PERSHUN SING, of Benares.  
 SYUD MEER LOOFT ALI, of Patna.  
 BABOO GUNGA PERSAUD GOSSAIN, of Serampore.  
 BUDRODEEN ALI KHAN, of Delhi.  
 BABOO DEENANATH.  
 BABOO DOTEERAM.  
 BABOO LOKEENATH.  
 BABOO MEENIRAM.  
 MOONG SHUAY OONG, of Moulmein.  
 ASHANORA.  
 AMOOG, a Chinaman settled in Assam.  
 ASSAM TEA COMPANY.  
 COSSIPORE SUGAR FACTORY.  
 SHAJEFANPORE SUGAR FACTORY.  
 The RESIDENT at Nagpore.  
 G. C. CHEAP, Esq., C. S.  
 E. A. READE, Esq., C. S.  
 R. N. MYTTON, Esq., C. S.  
 W. H. TYLER, Esq., C. S.  
 Dr. T. A. WISE, Dacca.  
 Dr. FALCONER, Calcutta.  
 Dr. JAMESON, Calcutta.  
 Dr. M'CLELAND, Calcutta.  
 Dr. C. HUFFNAGLE, Calcutta.  
 Dr. WALKER, Calcutta.  
 The Rev. M. STORCK, of Chittagong.  
 The Rev. W. T. HUMPHREY, of Moulmein.  
 The Rev. F. MASON, of Moulmein.  
 J. MARSHMAN, Esq., Serampore.  
 Mrs. MARSHMAN, Serampore.  
 Major JENKINS, Assam.  
 Major HANNAY, Assam.  
 Captain REYNOLDS, Assam.  
 Captain VETCH, Assam.  
 Captain BUTLER, Assam.  
 Captain BRODIE.  
 Captain D. REID  
 Captain A. PHAYRE, Arrakan.  
 Mr. SIMONS, Assam.  
 Mr. MARTIN, Assam.  
 W. S. HUDSON, Esq., Assam.  
 C. K. HUDSON, Esq., Assam.  
 Captain SMITH, Assam.  
 Lieutenant-Colonel MATHIE.  
 Major A. BOGLE, Tenasserim.  
 Captain MARQUARD, Chittagong.  
 Captain D. TAPLEE.  
 Captain BIRDMORE, M. A.  
 Lieutenant BAIRD, M. A.  
 Lieutenant SHARP, M. I.  
 Dr. MORTON, Moulmein.  
 R. C. MACRAE, Esq., Moulmein.  
 H. S. AUSTIN, Esq., Moulmein.  
 B. BEGBIE, Esq., Moulmein.  
 E. O. RILEY, Esq., Amherst.  
 G. R. GORDON, Esq.  
 A. WALLACE, Esq., Monghyr.  
 Messrs. TEIL, of Calcutta.  
 Messrs. HARTON, of Calcutta, Rope Manufacturers.  
 Messrs. THOMPSON, of Calcutta, Rope Manufacturers.  
 Messrs. J. MONTEITH and Co., of Calcutta.  
 Messrs. VARDON, of Soojapore.  
 Messrs. MATHESON and Co.  
 Mr. COCKBURN, of Moorshedabad.  
 Messrs. WATSON, of Moorshedabad.  
 Mr. WARNER, of Moorshedabad.  
 Mr. BLECHYNDEN, of Moorshedabad.  
 Mr. W. NORRIS, of Moulmein.  
 Messrs. HAMILTON, of Mirzapore.  
 D. JARDINE, Esq., of Calcutta.  
 A. EMERSON, Esq., Calcutta.







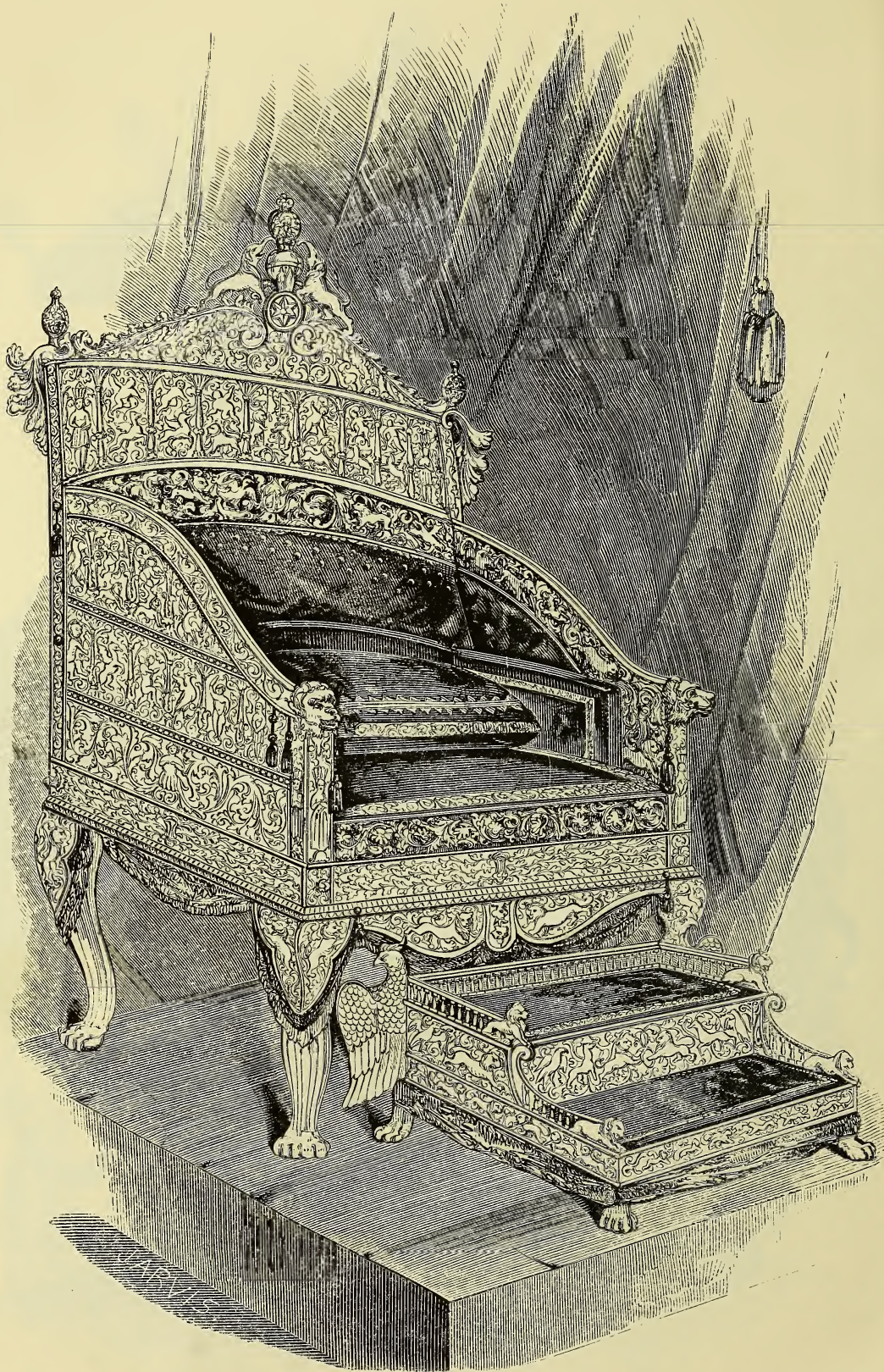

*From the Board of Administration at Lahore.*

H. H. MAHARAJAH GOOLAB SING, of Cashmere.  
H. H. the RAJAH of PATTIALLA.  
The RANEE SOOKHAN of SEHARUNPORE.  
The RAJAH of MUNDOTE.  
Major ABBOTT, Huzara.

*Contributors in the Bombay Presidency.*

H. H. MEER ALI MOORAD of KHYRPOOR.  
RAO OF CUTCH.  
R. N. C. HAMILTON, Esq., Bengal, C. S., Indore.  
W. MANSFIELD, Esq., C. S.  
H. REEVES, Esq., C. S.  
Dr. STOCKS, Scinde.  
Dr. GIBSON, Botanic Garden, Depooree.

*Contributors in the Madras Presidency.*

THE RAJAH of TRAVANCORE.  
THE ZAMORIN of CALICUT.  
THE ZEMENDAR of VIZIANAGRAM.  
NAWAB SIRUJ-AL-MOOLK of AURUNGABAD.  
G. S. NARRAIN, Esq., of Vizagapatam.  
T. L. BLANE, Esq., C. S.—Cannon from Kurnool.  
A. FREESE, Esq., C. S.  
DAVID PUGH, Esq.  
G. F. FISCHER, Esq., Salem.  
Dr. WIGHT, Coimbatore.  
Professor J. KEY, Madras.  
Captain H. S. BURNBY.  
W. ROBINSON, Esq., C. S.  
Mrs. BINNEY KEY.  
Mrs. S. GOODSIE.  
Dr. HUNTER, Madras.  
Lieut.-Col. TULLOCH, Commissary-General.  
Major-General CULLEN, Travancore.  
Major SMITH, M. E.  
Captain W. H. HORSLEY.  
Captain A. ORR, M. E.  
R. E. MASTERS, Esq.  
J. RHODES, Esq.  
Captain R. L. OGILVIE.  
D. MAYEW, Esq.  
Rev. C. F. MUZZY.  
T. BISHOP, Esq., Tanjore.  
Messrs. SIMPSON, of Madras.

*Contributions forwarded by the "Singapore Committee" from—*

GOVERNMENT of LABUAN.  
H. LOW, Esq.  
SULTAN of LINGA.  
R. BAIN, Esq.  
Messrs. ALMEIDA, of Singapore.

*Contributions received in this Country to the Indian Department.*

Her Majesty has graciously permitted the presents of the Nawab Nazim of Moorshedabad, and of the Rajah of Travancore, to be exhibited in the Indian department. The former consist of an ivory howdah, with elephant trappings complete, all worked in gold and silver. A throne or native reception-seat, with canopy and silver framework to support the pillows. Two moorchals, an emblem of rank, and two palanquins, one for state occasions, and the other without a canopy. The present of the Rajah of Travancore consists of a splendid ivory chair of state, with footstool, beautifully carved and jewelled.

His Grace the DUKE of DEVONSHIRE exhibits a silver filigree snake chain.

Lieut.-Col. SYKES exhibits in Classes XVII., XXVI., and XXVII.

Lieut.-Col. CAULFIELD.—An Indian battle-axe.  
Major MOORE, in Classes XX., XXIII., and XXV.  
Captain R. STRACHEY, B.E., in Class XII.

CHARLES READ, Esq., in Class XXIX.—A sandal-wood box,

J. F. ROYLE, M.D., in Class IV.

Mrs. ROYLE.—A Benares green and gold shawl and turban piece, in Classes XV. and XXX.

J. CHAPMAN, Esq., in Classes IV. and XXIX.

Mr. J. CLARKSON, in Class III.

Mr. J. GLADDING.—Pith figures, in Class XXX.

Captain JAMES, in Classes I., III., XX., &c.

J. TAYLOR, Esq., in Class XI.—Drawings of natives of Dacca employed in spinning, warping, &c., and in preparing cloth.

A. A. ROBERTS, Esq., in Classes XV. and XX.

T. E. J. BOILEAU, Esq., in Classes I., XVII., XXI., &c.

R. G. POTE, Esq., in Class XXX.—Translated Indian and American inscriptions.

G. P. JENNER, Esq.—Picture of the mosque at Beejapore.

Colonel BAGNOLD.—Model of field-gun.

Captain GORDON.—A yataghan, from Afghanistan.

Mr. COPLAND.—Kinkhob and daggers.

Mr. SAMUEL.—Shells, chiefly from Singapore.

—CAMERON, Esq.—Ivory plaited into a mat.

P. SCOTT, Esq.—Silver filigree inkstand.

Mr. HODGSON.—Tray of wools and fibrous substances.

Colonel GRIFFITH.—Model of great gun at Beejapore and of a gun-carriage.

Rev. W. ANTROBUS, in Class XXVI.

Dr. YOUNG.—Skins and heads of Indian animals.

Dr. BRUCE.—Stuffed specimen of Indian ox for the Ekka.

SAFFRON WALDEN MUSEUM.—Stuffed specimen of elephant for the Howda.

Mr. DURHAM.—A battle-axe, 376. Chowries from Arrakan.

*Observations on the Arts and Manufactures of India.*

The preceding enumeration of the articles in the Indian department of the Great Exhibition proves beyond doubt that India not only possesses a vast variety of raw materials, but is able to work them up into articles for daily use or for display on occasions of ceremony or of festivals, either of a religious or domestic nature. History informs us that India has from the earliest periods been distinguished for the richness of its natural products and for the elegance of its manufactured fabrics, also that an active commerce was established with Persia and Egypt, as well as with other northern nations, both by caravans with the aid of the "ship of the desert," and by sea through the medium of the Arabs who navigated the Persian and Arabian gulfs. The Chinese seem only to have made pilgrimages to India as the site of many of the shrines of Buddha. Though the Hindoos of modern times in general abhor the sea, yet the Ganges sustains its thousands of boatmen, and the coasts of Malabar and of Scinde produce a race of fishermen who pursue the shark for its fins and the polynemus for its swimming bladder, in order to satisfy the Chinese demand for gelatinous matters. That the Hindoos early paid attention to commerce we have proofs in the sacred law tracts called Institutes of Menu, promulgated at least 800 years B.C., and in which, as observed by Sir William Jones, "There is a curious passage on the legal interest of money, and the limited rate of it in different cases, with an exception in regard to adventures at sea, an exception which the sense of mankind approves, and which commerce absolutely requires, although it was not before the reign of Charles I. that our jurisprudence fully admitted it in respect to maritime contracts."—*Jones, 3rd Disc. and Rig Veda.*

Not only is it curious that the natives of India should so early have practised many of the arts and attracted the attention of foreign nations, but it is remarkable that they should have retained them through so long a series of ages, and carried them to so high a degree of perfection as to compete even in the present day with the looms of Lancashire and the fancy works of France. The ancient skill of Egypt we see only in the ruins of their temples or



in the paintings within their tombs. The arts of the Assyrians were hardly believed in until the disinterment of their cities revealed the skill, of which all traces have disappeared from the hands of its present inhabitants. China alone, like India, continues to practise arts which were not new even in times which are considered ancient in Europe.

The early civilization of India appears due to the natural fertility of the country and to the peculiarity of its climate, which enables its inhabitants annually to obtain two harvests off the same fields. Thus they sow wheat, barley, some pulses and oil seeds, in the autumn, and gather the crops in the spring of the year; while rice, the great and other millets with numerous pulses, are sown at the accession of the rainy seasons in June, and reaped at their conclusion in September. This facility in procuring food both for themselves and their cattle must early have afforded leisure to many, to pursue the arts which we have to notice, as well as to cultivate literature, and to originate some of the sciences which are not on the present occasion to be objects of our attention, such as grammar, poetry, philosophy, logic and law, geometry, arithmetic, algebra and astronomy, as well as medicine and chemistry, as we have endeavoured to show in a separate work, the "Essay on the Antiquity of Hindoo Medicine."

The diet of the natives of India is supposed to consist chiefly of rice: this is probably true only of Bengal; for in the north-western provinces wheat is much cultivated, and necessarily consumed, for it is not exported to any extent. The millets and pulses, as well as a variety of vegetables, form articles of diet, as well as milk and ghee, or clarified butter and condiments; and though the natives are thought to abstain from the flesh of animals, this is true only of particular castes, for many will eat fish, pursue the antelope, and hunt the wild boar—all for food. The Mussulmans, as is well known, abstain from the flesh of the hog as well as of the hare, but eat of the same animals as Europeans. Spirits distilled from sugar or the juice of palm-trees are extensively used, as well as the *aruk* of the Muohwa, or *Bassia latifolia*, which, being from a peculiar source, has been admitted into the Exhibition.

The clothing of the inhabitants must necessarily be suited to the climate, and for this the cotton, which is indigenous in their country, is admirably adapted. They were early acquainted with its use, for it is mentioned by Manu, and is supposed to be alluded to in the Rig Veda 1300 B.C. Calicoes and muslins being suited to the hot weather and rains, something more is required in the cold weather and rains, for which their stout calicoes, padded with raw cotton, are well adapted. But the wool of sheep, of the goat of the mountains, and of the camel of the desert, are all employed in the north-western regions of India, and woollen threads are mentioned by Manu. Silk of several kinds we have seen is indigenous in other parts of India.

The habitations of the Hindoo necessarily vary in different parts of the country, as the materials used depend upon its geological formation. In warm and moist parts, the bamboo serves every purpose, with palmyra or other large leaves, for roofing. If we go into Burma, we find the houses built on posts on the banks of rivers, so that the water flows under them. In the great plain of the Ganges, the huts are usually built of mud or of bricks, flat-roofed or thatched, and, in the hilly parts, of stone. In many parts the house and offices form a quadrangle, where the doors and small windows open inwards. In the Himalayas we have the houses and temples built of a framework of Deodar or cedar wood, filled up with stones, and with either flat or slated roofs, which project much beyond the walls, and cover open verandahs. The cattle are shut up in the lower, and the family occupy the upper, story.

The appearance of the inhabitants of many parts of India is admirably represented in the series of figures exhibited from different parts of India. The soft and delicate-limbed Bengallee is well represented in the models from Kishnagurh, and the tall and slender inhabitant of

Southern India in the figures exhibited by Mr. Boileau. But that all are not so effeminate-looking may be seen in the model of the Jummabundi, where all the castes of the Dekkan are shown, as also in the well-clothed inhabitants from Belgaum and North-west India, and of Thugs in the model exhibited by Captain Reynolds.

In these models we also see the natives occupied at their various trades, as those of the carpenter, sawyer, and blacksmith. Some we see employed in ploughing, in grinding corn, in cooking, and in washing; men and women cleaning, spinning, preparing the thread, and weaving the cotton: others employed in pottery, in calico-printing, and working in the precious metals.

"That the useful arts have long been very numerous among the Hindoos," we have observed on a former occasion, is very evident, for Sir William Jones says, "That Europeans enumerate more than 250 mechanical arts, by which the productions of nature may be variously prepared for the convenience and ornament of life; and though the Silpi Sastra (or Sanscrit collection of treatises on arts and manufactures) reduces them to 64, yet Abul Fazl has been assured that the Hindoos reckoned 300 arts and sciences: now, their sciences being comparatively few, we may conclude that they anciently practised at least as many useful arts as ourselves."—(*Jones, tenth disc.*) With respect to their skill in many of these arts, we may adduce the unexceptionable evidence of the late excellent, widely and universally esteemed Bishop Heber: "To say that the Hindoos or Mussulmans are deficient in any essential feature of a civilized people, is an assertion which I can scarcely suppose to be made by any who have lived with them. Their manners are, at least, as pleasing and courteous as those of the corresponding stations of life among ourselves; their houses are larger, and, according to their wants and climate, to the full as convenient as ours; their architecture is, at least, as elegant. Nor is it true, that in the mechanic arts they are inferior to the general run of European nations. Where they fall short of us (which is chiefly in agricultural implements and the mechanics of common life), they are not, so far as I have understood of Italy and the south of France, surpassed in any great degree by the people of those countries."

The accounts which we have hitherto had of the tools and methods employed by the natives in the useful arts have been brief, and usually written by those unacquainted with the processes which they described, sometimes prompted by partiality, often dictated by prejudice. The present affords an excellent opportunity for those practically acquainted with the several arts in Europe to compare the tools used by the natives of India with the results of their labour, and both with the tools, textile fabrics, and cunning works of the hand, in wood, stone, horn, ivory, and in the precious metals from other parts of the world. It must first, however, be observed that the tools and machines which are exhibited have been collected from a vast extent of territory, the different parts of which do not differ more from each other in the state of the arts than sometimes do two parts of the same district, for instance, the plains and mountains. The tools, if we judge by their appearance, are, in general, rude enough and simple in construction; but, if we judge of their fitness by the effects which are produced, we must allow that they are as effective as tools can be, and, like more finished instruments, require only hands capable of using them. There is little doubt that among these are some which have a great resemblance to the tools represented in the Egyptian paintings; and some of them were doubtless the originals of such as are now employed in Europe.

One thing is very remarkable, and that is the few tools which they employ for processes, for which, in Europe, a variety are provided. Mr. Petrie, himself an engineer, has described how they make one tool serve a variety of purposes. For instance, a carpenter will have a chisel and a plane, and a tool of a wedge-like shape, sharp at one end and broad at the other, which they use for various purposes. "If they want an axe, they have a handle

with a hole, into which they put the above tool, and make an axe of it. If they want an adze, they turn the same tool round. When they wish to drive in nails or to make use of their chisel, they employ the same tool as a hammer. If they wish to split a billet of wood, they get two or three of these tools, and put them into the wood as wedges, and strike them with another billet, and thus they manage all their work: that tool, and the chisel and plane, are all they have, and they turn out very good work with them." He adds, that he "found them very teachable, and that, in a short time, almost an incredibly short time, they learned to make up the machines I required," that is, saw-gins. But the number of tools employed are much greater in other parts of the country, as for instance, the ivory carvers of Moorshedabad, and the workers of silver filigree-work at Cuttack. But the elaborate carving of the Bombay furniture is said to be effected with a single tool, while the delicate and beautiful pith temples and figures from Trichinopoly are made with only two knives.

A higher state of invention is displayed in the auger, on the plan of Archimedes' screw, in which a semi-rotatory motion is given by moving a cylindrical piece rapidly up and down the shaft. This is probably a Chinese invention, as it seems to be best known in the southern parts. Such an instrument has only of late years been invented here, and a patent taken out for it. The natives of India make use of a very efficient drill, of which one has been sent from Berhampore, as used by the ivory carvers. A very complete set of the instruments used by the different trades in Nepal was sent, but many of the labels have been lost.

The ingenuity of the natives is conspicuous in their smelting iron, with no other means than what they procure on the spot where the ore is found; for instance, they cut down the wood and make charcoal, and with the large leaves of trees they make a bellows, of which a specimen has been sent from Mirzapore; but others, formed of two cylinders, and another with a double valve, show a higher state of invention.

Their ingenuity is further well shown in the skill with which they combine the soft resin of lac, sand, and powdered corundum, so as to obtain a grindstone fit for polishing precious stones, as well as for sharpening the hardest steel.

Their mills for pressing oil seeds and for crushing the sugar-cane, and for separating cotton from its seeds, all display ingenuity, which there is no doubt must have been displayed at very early periods; but it is remarkable that the faculty of invention and the desire of improvement should for so many ages have remained stationary, for there is no doubt that many of the tools and machines might be improved, friction diminished, and yet their simplicity retained.

In Class VII. we have a few instances of the civil engineering of the natives, as shown in their contrivances for raising water as well as for crossing rivers. Only one model has been sent of a great public work, that of the great dam, or annicut weir, thrown across the Godavery river, in order to raise its water for the purpose of irrigating a large tract of land.\* Models of the great works which have been constructed for the Delhi and Doab Canals, and are now constructing for the Great Ganges Canal, would have been instructive even in Europe.

The models of the vessels which navigate the Indian seas have been sufficiently described in Class VIII. It is not probable, though far from impossible, but that some

hints may be obtained even from them; for the improvement of ship-building; for some of the vessels which navigate the China and Indian seas are remarkable for their swiftness. The first class "Sampan," from Singapore, is distinguished as such, while of the yacht "Wave," of which the model was taken from a fishing-boat of Bombay, it is said that no boat of European form and construction has yet been found to compete with her in point of sailing in moderate weather. The batelles of the Arabs, especially those of the Joaseme pirates of the Persian Gulf, called Trankey by Europeans, were, from their swift sailing, at one time very destructive to trade, because no vessel could escape them, and their weathery qualities prevented square-rigged ships from capturing them, except in strong breezes. An Indian officer writes, that "The Arabs say their fame has now passed away, by the introduction of steam, previous to which there was no vessel ever built that could sail so close to the wind. The batelle always carries three suits of sails, the larger size of very fine cotton canvas, made at Bahrein, wove by hand; this sail is bent for light winds, and when the wind is too fresh to carry it, it is lowered, and a smaller one of coarser canvas bent: the third is for a fresh top-gallant breeze, but when it blows hard, they lower down the yard, and hoist a triangular sail like a jib.

"In 1817, whilst the writer was a lieutenant of the Honourable Company's gun-brig 'Psyche,' sailing along the coast of Scinde, in company with H.M.S. 'Eden,' Captain Loch, it had been blowing very fresh in the morning, when the 'Eden' came up with three of the Joaseme batelles, when under their small sails, with a native prize-boat in tow.

"On the 'Eden' firing a gun, the pirates lowered their sails, on which the 'Eden' shortened sail to topsails, and lowered a boat to board them—Captain Loch thinking they had lowered their sails for the purpose of being examined; but, on the boat sent from the 'Eden' closing with them, they hoisted their large sails which they had been bending, cast off the prize which they had in tow, and made off, passing between the 'Eden' and the Honourable Company's cruiser, receiving the distant fire of both vessels. The ships followed in chase the whole day, but without success, the pirates just keeping out of shot with their sweeps, and laying them in as the breeze freshened, by which means they gained on their pursuers."

In the collection of *Arms* we have a curious display of what would seem to be drawn from a museum, storing the productions of various ages, but which are actually the arms in present use in different parts of India. Thus we have the bows and arrows as well of Assam as of North-west India. Shields from both localities, as well as from Cutch. Spears and battle-axes, two-handed swords, and daggers in every variety. Chain as well as sheet armour both for man and horse, with plumes for the helmet. Along with these we have the match-lock, flint-gun, and detonating lock; the two latter imitated from European models. Guns to be carried on camels, others to be mounted on hills. Models of cannon and of mortars from Lahore, all indicating the attention paid by the natives of India to arms. This is especially conspicuous in the care and taste with which many of them, as well as the accoutrements, are ornamented. Among the curiosities may be mentioned the shield with four pistols concealed in its centre; complicated daggers, and one which, in striking, separates into five blades; a sword which separates into two, and another with pearls let into the middle of its blade. They all indicate the skill of the armourer, some of whom always form a part of the regular establishment of princes in the East. But the steel of the beautiful Damascus blades, the twisted barrels of the match-locks, and the skill with which the blade of one dagger is concealed within another, are to be admired as specimens of the workmanship of the natives of India as cutlers and gunsmiths, even in the midst of the works of industry of all nations.

*Agriculture* is an art which must have been earliest

\*The following is a statement of the chief measurements of this work, as detailed on the model:—

Dowlaiswaram Annicut across the Godavery River commenced 1847. Extreme length, 7,200 yards. Combined length of weirs, 4,400 yards. Height of weir, 12 feet. Depth of water during floods, 17½ feet. Extreme discharge, 180,000,000 cubic yards per hour. Quantity of water to be distributed for irrigation, 1,000,000. Extent of delta land to be irrigated, 1,000,000 acres. Length of irrigated tract, 100 miles. Greatest breadth of tract, 40 miles.

Materials consumed up to December, 1850.—Stone, 400,000 tons. Bricks, 4,400,000. Lime, 800,000 cubic feet.

Required—Stone, 100,000 tons. Lime, 70,000 cubic feet.

practised by those nations who first gave up the nomade for a settled, necessarily an agricultural, life. There is every reason to believe that the Hindoos were among the earliest civilized nations. Indeed, their earliest records, the hymns of the Rig Veda, composed probably fourteen centuries B.C., contain supplications for abundant rain and for the fertility of the earth. The agriculture of India, like its other useful arts, has been unreasonably depreciated by some, and perhaps as erroneously overpraised by others. But the farming of different parts of the country varies much; but in all, the ryots pay great attention to the variety of soils, and to the plants which are best suited to each. They well understand the rotation of crops; the value of a fallow, as well as of weeding; and of manuring, though they only occasionally practise it, and for particular crops, as sugar-cane and tobacco; for the manure of the cattle is unluckily lost, from the unfortunate practice of using it as fuel. The practice of sowing several crops together is, no doubt, detrimental to some; but the Indian farmer adduces as his excuse that, in an uncertain climate, it gives him the advantage of escaping entire loss; for, when one crop fails, another may be saved by later rains. Great attention is paid to irrigation, which is as important in India as draining is in Great Britain, and this so much so that nothing would benefit the country so much as facilitating, by every method, the raising of water in most parts of the country for the purposes of irrigation.

The tools which are in use are sufficiently numerous, but they are rude in appearance, and simple in construction; though, as far as the effects are concerned in favourable seasons, they must be considered efficient; for the crops are usually luxuriant, and the proceeds abundant. It is remarkable that, in the whole of the west of India, from Guzerat to Mysore, a drill plough is employed for sowing the majority of crops. This is in the form of a three or four toothed harrow, behind each tooth of which terminates a bamboo tube, having its other end fixed in a central seed-cup, which has as many holes in its lower part as there are tubes attached to it. Colonel Sykes has observed that there are two kinds of drill plough; one heavy, called *maghur*, used for grain (pulse), wheat, and safflower; the other is less heavy, and called *pabhur*, used for millets and the smaller pulses, on light soils. When the cultivator wishes to sow a different grain in one of the furrows made by the teeth of the harrow, he stops up one of the holes, and has a separate tube following at a short distance behind. As the whole of the sowing apparatus is removeable at pleasure, he can use the body of the instrument, with its teeth, as a harrow, by laying aside the seed-cup with its tubes. The whole cost of the instrument is about three rupees. This drill-plough seems to have been used in Guzerat, and probably other parts, from time immemorial. We may suppose that it was used even in the time of Alexander, for Theophrastus describes the cotton as being sown in the plains, arranged in rows, so as to look like vines at a distance. His informants could only have seen cotton cultivated in the western parts of India. In Europe, the drill-plough is said to have been first employed in Spain, towards the end of the seventeenth century. It has already been said, with reference to the tools, that "if the simplicity of his plough neither entails upon the native farmer additional labour, nor a more scanty harvest, nor an increased expenditure, we do not see that he is much to be pitied."

From the number of *Musical Instruments* which have been sent from India, it would appear that considerable attention must there be paid to music, and we might infer that the science had made some progress. It is treated of in one of their ancient *Upavedas*, and the natives have been heard to say that, though Europeans excel them in many things, they excel Europeans in music. But we know not any European who agrees in this. Orme, indeed, says "that their ideas of music, if we may judge from their practice, are barbarous." Sir William Jones, however, believed that "the Hindoo system has been formed on truer principles than our own; all the

skill of the native composers is directed to the great object of their art, the natural expression of strong passions, to which, indeed, melody is often sacrificed; though some of their tunes are pleasing, even to a European ear." The effects which they ascribe to some of their *ravags*, or ancient melodies, are quite as extraordinary as those ascribed to Orpheus, or to Timotheus. Sir W. Ouseley says, "that a considerable difficulty is found in setting to music the *rags* and *ruginis*, as our system does not supply notes or signs sufficiently expressive of the almost imperceptible elevations and depressions of the voice in those melodies, of which the time is broken and irregular, the modulations frequent, and very wild." It is remarkable that, in the histories of music, no notice is taken of that of India; though it is probable that an investigation of the musical instruments at present in use in India, and of their system of music, would throw much light upon that of the Egyptians, and of the instruments mentioned in the Bible.

Among the instruments at present in use in different parts of India, we find some rude enough in structure and appearance, but interesting, as natural objects made use of to produce sounds; as, for instance, horns, as blowing instruments; and gourds, as sounding-boards to their stringed instruments; bamboos, as pipes; and sets of them, of different sizes, to produce differences of sound.

The instruments used by the natives of Moorshedabad and of Benares consist of both wind and stringed instruments, and of drums, tambourines, and cymbals. A long list is given of the musical instruments used by the Arabs and Persians in the Introduction to Richardson's Dictionary, where it is observed, that "The Asiatics have a great variety of instruments; and many of those now in use amongst us, though considerably improved, appear to have been originally of eastern invention."

The Malay musical instruments are described as being so numerous, that about thirty are required to form a full band, or *gamalong*, costing about 2,000 rupees. Among these are conspicuous those in which gongs, as well as drums, of different sizes, and pieces of metal and of hard wood, of different lengths, are employed to produce different tunes, when struck with suitable gong—or drum—sticks.

The *Manufactures* of India may be noticed in the order in which they are arranged in the Catalogue. Among these, cotton still takes the precedence even in India, though it has greatly fallen off in importance since the machinery of Europe has been able to supplant, even in their own markets, the cheap and durable products of Indian looms. From an examination of the cottons produced in the places where the manufactures have attained the greatest perfection, we do not find that it is owing to any superiority in the raw material, but owing to the great pains taken by the native spinners and weavers, and their matchless delicacy of touch. Specimens of the cotton manufacture have been sent from Bengal, and from all along the Ganges up to the Jullundur Doab, from Ahmedabad and Surat on the west, and from the Circars on the south-east coast, also from as far south as Tanjore. It is curious that some of the places celebrated for their manufactures do not grow the cotton which they weave; for instance, Azimgurh, bordering on the Oude and Chundeyree, in the Gwalior territory. The Circars used to import their cotton from Central India.

In the Exhibition we have numerous indications of the pains taken by the Hindoos in the preparation of their cotton. First, several machines, rollers and churkas, for separating the seed from the cotton; also the bow, for further cleaning or teasing the cotton, other apparatus for preparing the thread, and looms for weaving it.

Mr. James Taylor, in the Report referred to at page 858, on the manufactures of Dacca, has given much interesting information on this subject, as well as sent a number of articles and drawings explanatory of the process. Thus, along with the raw cotton of Dacca is exhibited "the primitive instrument used for carding the fibres of the cotton." This is simply the jaw-bone of the Boolee fish

(*Silurus boalis*), the teeth of which being fine, recurved, and closely set, act as a fine comb in removing minute particles of earthy and vegetable matter from the cotton. The Hindoo spinner, with that inexhaustible patience that characterises her race, sits down to the laborious task of cleaning with this instrument the fibres of each nob of cotton. Having accomplished this, she then separates the wool from the seeds by means of a small iron roller, which is worked with the hands, backward and forward, on a small quantity of the cotton seeds placed upon a flat board. The cotton is next bowed with a small bow of bamboo, strung with a double row of catgut, muga silk, or the fibres of the plantain tree twisted together; and having been reduced by this instrument to a state of light downy fleece, it is made up into a small cylindrical roll (*puni*), which is held in the hand during the process of spinning. The spinning apparatus is contained in a small basket or tray, and consists of a delicate iron spindle (*tukooa*), having a small ball of clay attached to it, in order to give it a sufficient weight in turning, and of a piece of hard shell, imbedded in a little clay, on which the point of the spindle revolves during the process of spinning. With this instrument the Hindoo women almost rival Arachne's fabled skill in spinning. The thread which they make with it is exquisitely fine, and doubtless it is to their delicate organization, and the sensibility with which they are endowed by nature, that their inimitable skill in their art is to be ascribed. The finest thread is spun early in the morning, before the rising sun dissipates the dew on the grass; for such is the tenacity of its fibre, that it would break if an attempt were made to manufacture it during a drier and warmer portion of the day. When there is no dew on the ground in the morning to indicate the presence of moisture in the atmosphere, the spinners impart the requisite degree of humidity to the cotton by making the thread over a shallow vessel of water. The various implements used in the preparatory processes of weaving are the reeds for winding the thread, the hand-wheels for warping, the sley-hook and reed, and the apparatus for forming the heddles. During the process of preparing the thread, and before it is warped, it is steeped for a couple of days in fine charcoal powder soot, or lamp-black mixed with water, and after being well rinsed in clear water, wrung out, and dried in the shade, it is rubbed with a sizing made of parched rice (the husk of which has been removed by heated sand), fine lime and water.

The principal varieties of plain muslins now manufactured at Dacca are, Mulmul Khas, Ab-ruwan, Shub-num, Khasu, Jhuna, Sircar Ali, Tun-zeb, Alabullee, Nyanzook, Buddun Khas, Turundam, Surbutees, and Surbund—names which either denote fineness, beauty, or transparency of texture, or refer to the origin of the manufacture of the fabrics, or the uses to which they are applied as articles of dress. The finest of all is the Mulmul Khas (literally muslin made for the special use of a prince or great personage). It is woven in half pieces, measuring 10 yards in length and 1 yard in breadth, having 1,900 threads in the warp, and weighing 10 siccas (about 3½ ounces avoirdupois). The finest half piece that I have seen weighed 9 siccas. The price is 100 rupees. Some of the other muslins are also beautiful productions of the loom, as Ab-ruwan, compared by the natives, from its clear pellucid texture, to "running water." Shub-num, so named from its resemblance, when it is wetted and spread upon the bleaching field, to the "evening dew" on the grass. Jhuna, a light, transparent net-like fabric, usually made to order, and chiefly for natives of rank and wealth, worn by the inmates of zenanas and dancers, and apparently the cloth referred to in the classics under the figurative names of *Tela arenarum*, *Ventus textilis*. All these muslins are made in full pieces of 20 yards in length by 1 in breadth, but varying considerably in the number of threads in the warp, and consequently in their weight.

Of figured fabrics, as striped (Doorea), chequered (Charkanee), and flowered (Jamdanec), there exists a

considerable variety, both in regard to quality and pattern. The flowered muslin was formerly in great demand both in India and Europe, and was the most expensive manufacture of the Dacca Urungs. There was a monopoly of the finer fabrics for the Court of Delhi: those made for the Emperor Aurungzebe cost 250 rupees per piece. This muslin is still much admired, but it is now seldom manufactured of a quality of higher value than 80 rupees per piece.

Omitting the second-rate kinds of cloth, as Sarcees, Boonees, Baftas, Jon, Ekpattus, Gamchas, &c., now entirely made of English yarn, imported into the district, and which constitute the great bulk of the Dacca cotton manufacture, the next class, of which specimens should be exhibited, is that of fabrics of a mixed texture of cotton and silk. They are designated by various names, as Nowbutta, Kutun, Roomee Apjoola, and Sirka; and when embroidered with the needle, as many of them frequently are, they are called Kusheedu. The silk used in their manufacture is the indigenous Muga silk of Assam and Sylhet, but the cotton thread employed is now almost entirely English yarn, of qualities varying from No. 30 to 80. These cloths are made exclusively for the Jeddah and Bussora market, and a considerable stock is yearly imported in the Arab vessels that trade between Calcutta and these ports. Pilgrims, too, from the vicinity of Dacca, not unfrequently take an investment of them, which they dispose of at the great annual fair held at Meena, near Mecca. They are used by the Arabs chiefly for turbans and gowns. The golden colour of the Muga silk gives to some of these cloths a rich lustrous appearance. A few pieces, made of native-spun cotton thread, and of the best kind of Muga silk, would, I have no doubt, be admired in this country.

Embroidery (*Zur-dooze*) is an art, in which the Mahomedans of Dacca display a degree of skill almost equal to that exhibited by the Hindoos in weaving. They embroider Cashmere shawls and scarfs, also muslins, and net fabrics with silk, gold and silver thread. These fabrics are much esteemed in this country, and are probably still unrivalled by similar productions in any part of the world.

Another branch of needle-work allied to embroidery, which is carried on here, is that of flowering or ornamenting cloths with cotton thread (*Chikan-kavi*). The dresses of Mahomedans are frequently worked in this manner, and two descriptions of it called Tartor and Sununderludur, in which the texture of the cloth is broken down with the needle and converted into network, are held in the highest estimation.

In commissioning fine muslins from Dacca, ample time should be given for their manufacture. The time required for the preparation of a piece varies from one to four months, according to the quality of the fabric, the latter being the period necessary for the weaving of a half-piece of Mulmul Khas. The best season for making this kind of muslin is during the months of May, June, July, and August. If several pieces of the finer kinds were to be manufactured, a full year's notice would be required in order to procure the necessary quantity of thread.

Chittagong, which formerly possessed a factory subordinate to the one at Dacca, still manufactures inferior fabrics of strong texture. The rough towels made here are of an excellent quality; they are stout and durable, and would be found to be superior to the Baden towels, now so much used in dressing rooms in this country.

The Garrow, Tipperah, and Chittagong hills produce a large quantity of inferior cotton, called Bhoga. It is the principal article of traffic which the hill people bring down to the plains. It is used in the manufacture of the inferior kinds of hummums, baftas, boonees, sarcees, jore, &c.; also for making ropes, tapes, and the coarsest of all fabrics, viz., garhahs and gazeehs, which are commonly used for packing other cloths, and for covering dead bodies, for which purpose a large quantity of these is consumed annually both by Hindoos and Mahometans.

As Dacca was formerly famous for its muslins, so were

the Northern Circars for their long cloths. The former has sent some beautiful specimens of muslin, both plain, figured, and embroidered with silver. But Chandeyree, far in the interior of India, in the Gwalior territories, has also sent some beautiful muslins. These are manufactured of cotton grown at Nimar, some hundred miles distant. From the dryness of the climate the weavers, who are Mahomedans, are obliged to weave these fine muslins in underground workshops. The finest piece of long cloth has been sent by Mr. Masters, from Jugginpettah, in the Northern Circars. Fine muslins have been sent from Arnee and from Oopada, and beautifully embroidered beetlewing dresses from Madras.

Some of the fabrics of cotton are extremely interesting as specimens of skill in weaving, as those in which patterns are woven throughout the piece, and others as specimens of double weaving; whence two distinct coloured cloths appear to be united together, and alternately show themselves on opposite sides.

The woollen fabrics are not so likely to be of a superior quality from a hot country, but it is interesting to have them from the mountains of Mysore and the plains of North-Western India, and also of the wool of the sheep and of the hair of the camel. The kid cloth of Cashmere is beautifully soft, and a new fabric called Pareevuz, of which the pile of one surface is formed of loops, is interesting, but the shawls of Cashmere are celebrated throughout the civilized world. Moorcroft informs us that the wool used in the manufacture of the shawls of Cashmere is of two kinds. Of these one is called Pashm shal, and the other Asali toos, the former being obtained from the goats in a domesticated state, and the latter from the wild goats and wild sheep, &c. All these animals, as well as the yak and dog, in the elevated, cold, and dry regions of Tibet, being furnished with a fine down, or hair-like wool, under the coarse common outer wool. This is brought from the different parts of Tibet to Ladakh, where it is purchased for or by the Cashmerians, and carried into their valley. Much of it is white, and sold a few years ago for 4s. a pound; the dark-coloured is well suited for dyeing. The long hairs are picked out, the remainder carefully washed in rice-water, and then hand-spun by women. A variety of hands are necessarily employed in the manufacture of shawls. An artist designing the patterns might obtain a sale for them even in Europe, as they are so generally admired and imitated. A man is employed in determining the quality and quantity of thread required for a pair of shawls, and another in arranging the warp and woof (the former of which is generally of silk) for the border. The yarn is first dyed; the Cashmerians professing to employ sixty-four different tints. The shawl is carefully washed when the weaving is completed, and the very finest are said to be washed in a lather formed of soap berries.

A sub-committee having been appointed in Calcutta to report upon the subject of Cashmere shawls, Benares' brocades, and Dacca muslin, have furnished a report which is particularly valuable, from Dr. Falconer, one of the members, having been for some time in Cashmere, and acquired information which is not otherwise obtainable. It is therefore here published.

"The Sub-Committee appointed to report on Cashmere shawls, Dacca muslins, and other articles of manufacture that may require considerable time for their preparation, having met and considered the subject referred to them, submit the following as their report:—

"1. Cashmere shawls. The Sub-Committee are of opinion that the Cashmere shawl fabrics are more likely than any other article of Indian manufacture to admit of successful competition with the productions of the looms of Europe, and that no exertion ought to be spared to get the best description procurable. These are not readily found in the market, and, if made to order, a pair of shawls of the richest pattern will occupy from a year to eighteen months in the manufacture.

"2. The articles made of shawl wool are of infinite variety, ranging from carpets, quilts, saddle-cloths, cano-

pies, dish-covers or napkins, to shawls, gown-pieces, cravats, turbans, choghas or cloaks, waistcoats, stockings and gloves, embracing almost every kind of fabric used as an article of dress. But the Sub-Committee are not prepared to recommend that all these fabrics should be sent to the Exhibition. They leave the consideration of the selection to the deliberation of the General Committee.

"3. The principal articles of peshmina or shawl-wool manufacture may be classified under the following heads:—

- I. Doshalla or long shawls  $3\frac{1}{2}$  by  $1\frac{1}{2}$  guz.
- II. Kussaba or square shawls  $1\frac{1}{2}$  or  $2\frac{1}{2}$  guz square.
- III. Jamewars or striped shawl pieces  $3\frac{1}{2}$  by  $1\frac{1}{2}$  guz.
- IV. Ulwan or plain white shawl cloth.
- V. Miscellaneous, such as carpets, saddles, saddle-cloths, and various articles of dress, stockings, gloves, turbans, &c.

"I. *Doshallas or Long Shawls.*

"4. Doshallas or long shawls, invariably manufactured and sold in pairs, are the most esteemed production of the looms of Cashmere. They vary greatly according to the richness of the patterns, all of which are distinctly named, and according to the colours of which the dyers profess to make upwards of fifty tints, but the Sub-Committee will confine themselves to the leading colours, viz., black, white, crimsons, purple, blue, green, and yellow.

"5. Of the finest doshallas, the principal varieties in pattern depend upon the amount of decoration of mitton or centre-piece, the pulla or border-pieces being always richly flowered. The following are the leading kinds:—

1. Khale mitton or plain field shawls.
2. Poor mitton or full-flowered field.
3. Chand-dar, chantahi-dar, alifda koonj bootha-dar.

According to ornament, being a moon or circle in the centre, four half moons, green sprigs on a plain ground; a group of flowers at the corners, or any combination of these.

"6. The Sub-Committee would restrict their consideration of the colours to eight kinds, viz.: 1. White, sada or safaed. 2. Black, moosheke. 3. Crimson, goolanar. 4. Scarlet, kermisi. 5. Purple, ooda. 6. Blue, ferozee. 7. Green, zingaree. 8. Yellow, zurd.

"6 $\frac{1}{2}$ . Fine long shawls with plain fields of handsome patterns (khalli mitton), are procurable at about 1,200 rupees per pair; and full flowered, poor mitton, at about 1,500 rupees. Taking the average of these 1,350 rupees, as representing the price of the third class, including chand-dar, chontahi-dar, &c., and as the average price of the whole; and supposing a pair of each of the above eight colours were ordered of the three several classes of pattern, we should have twenty-four pairs of shawls, at 1,350 rupees, making 32,400 rupees in all.

"7. In framing this part of the estimate, the Sub-Committee do not mean to recommend that the order should be so extensive; they are simply desirous of furnishing to the General Committee the detailed grounds upon which a suitable selection could be made. If the shawls were ordered single, instead of in pairs, which they believe to be practicable although not the custom, the estimate would be reduced to 16,200 rupees. Further, they would suggest that some of the wealthiest native gentlemen about Calcutta be solicited to send their best shawls of different colours for the inspection of the General Committee so as to simplify the labour of selection. The government tosha khana might also furnish a considerable number of various patterns.

"II. *Kussabas or square Shawls.*

"8. Kussabas or square shawls, called also Roomals, are of two classes, viz., Kanee roomal, or loom-manufactured, and Umlee roomal, or needle-embroidered shawls. In form they are more suited to the taste of the Europeans than the long shawls, and are made and sold singly. They run through the same range of colour and pattern as the long shawls, and the Sub-Committee frame their provisional estimate accordingly. The needle-worked kinds are

much cheaper than the loom-manufactured, and the embroidery is far superior in pattern and execution to the scarfs and shawls embroidered at Delhi. Assuming eight colours and three patterns of each of the Kanee roomal, at an average of 400, 300, and 500 rupees each, twenty-four square shawls would cost 9,600 rupees; and the same number of needle-worked of Umlee roomals, at an average of 225, 150, to 300 rupees, would cost 5,400 rupees.

### “ III. *Jamewars.*

“ 9. Jamewars form the third great class: they are handsome striped loom-wrought fabrics of rich patterns, of which the French striped coloured muslins are printed imitations. They are manufactured of an infinity of patterns, but the principal kinds are the Rega-bootha or small flowered, the Kirkha-bootha or large flowered, and the Jhaldar or netted patterns. The most elaborately worked cost as much as 2,000 rupees each. Ten pieces would include a fair variety of patterns at an average, say of 600 rupees each, making 6,000 rupees.

### “ IV. *Ulwan.*

“ 10. Ulwan, or plain shawl wool-cloth, is woven like plain muslin without flower or ornament, and is made in pieces of various lengths. It forms the centre portion or mitten of shawls, and is used for turbans and cummurbunds. It is well adapted for ladies' dresses. Eight pieces of twenty yards each of the different colours above named, at six rupees per yard, would cost 960 rupees.

“ 11. Another fabric is made which may be included under the same head as Ulwan, called Muleedah pushmina, being intended to imitate European broad cloths. It is formed of Ulwan, manipulated in a peculiar manner in water, so as by rubbing to tease out the wool of the thread and raise it into a nap. A piece of twenty yards, at six rupees, would cost 120 rupees.

“ 12. A coarser fabric, of the same class, is manufactured in the Hill State, to the north-west of Simla, called Puttoo peshmina, which possesses great softness and warmth—in many respects rivalling fine broad cloth.

### “ V. *Miscellaneous.*

“ 13. The miscellaneous articles of shawl-wool fabric are exceedingly numerous. They may be classified—

“ 1. Articles of dress:—Choghas Ulkbaliks, Pasteen Shumlas, or Cummurbunds and Loongees, made in imitation of the silk Loongees of Mooltan Gosh-pech, or Dusstars turban pieces. Gulloobunds or cravats, of great variety. Pistan Bunds or neckerchiefs. Nukash Zerposh or trousers. Takhum caps. Toorab. Short stockings (Gooldar), flowered and Nuhramat stripes. Moseh long stockings. Charkhanna or loose robe for women.

“ 2. Articles of furniture:—Khalin Peshmina carpets. Durpurda and Takposh screens and curtains, for doors, windows, and recesses. Pulung-posh or quilted coverlets. Khan-posh, dish-covers, and napkins, horse furniture, &c. Kuzzur-i-asp, saddle-cloths. Kuzzur-i-fl, elephants' housing. Sacewan or canopies, tents, &c.

“ 14. The Sub-Committee have not gone into the details of the prices of these miscellaneous articles, as they do not consider the arrangements requisite for procuring them to be of the same emergent character as those required for the leading classes of the shawl articles. With regard to the latter, they are of opinion that no time should be lost in determining the number and variety of the articles required for the Exhibition, and in submitting a representation to Government on the subject, that the necessary measures for procuring them may be put immediately in operation.

“ 15. The Sub-Committee find, from a memorandum communicated to them by one of their members, that Kimkhab, Tass, Budlas, and other descriptions of ordinary brocades, are readily procurable to order on two months' notice, at Kassim Bazaar, and Benares. With respect to these articles, therefore, it is not necessary to anticipate the reports of the local committee at those stations. But there is a gorgeous and very expensive class of brocades, manufactured with solid gold wire

drawn out into fine thread, which cannot be had without six or eight months' previous notice. They would recommend, therefore, that three pieces of Kim-Khab, and three of Tass, of the latter description, be provided for on emergent order.

“ 16. With regard to Dacca muslins, the Sub-Committee understand, from a memorandum furnished by Mr. Agabeg, that the finest descriptions, such as Muhnul-Khas, take fully twelve months to prepare, one sicca weight of the thread requiring three months to be spun. They would recommend that measures be adopted for an immediate order of the fabrics of this description. A detailed memorandum with an estimate of the prices are appended.

“ 17. The procuring of the more ordinary sorts of Dacca muslin may be left to the Dacca Local Committee to arrange for.

“ 18. The Sub-Committee have confined their attention to the three classes of fabrics above reported on, viz.: Cashmere shawl fabrics, brocades, and Dacca muslins.

“ H. FALCONER, M.D.

“ JOSEPH AGABEG.

“ JORYKISSEN MOAKERJEE.”

*Silk* has long been known in India, but is supposed by some to have been brought from China, as in some old works it is called cloth of China; but we know that there are also several species of silkworm, as the Tussur, Eria, Mooga, and Gooree, indigenous to the forests of different parts of India. The silk of Bengal was originally inferior in quality and carelessly wound. The East India Company, in the year 1757, sent a Mr. Wilder to improve the winding of silk, and, in the year 1769, other Europeans, as drawers, winders, reelers, and mechanics. The filatures were all in Bengal, to the southward of 26° of N. latitude, for the north-west provinces are much too hot and dry for the silkworm. It is probable that the silk culture might easily be carried on in the valleys of the Himalaya. Some fine specimens of raw silk have been sent from Bengal, as well as from Mysore. The silk goods sent by Messrs. Jardine and by Messrs. Vardon have been much admired, as well as the Cashmere silks, for their substantial nature and for their moderated tone of colouring. On the Bombay side we may see that the raw material is imported from Bengal and from China, and that the manufacturers have attained a high degree of skill and excellence. Among these are pieces of silk which, like the cottons mentioned before, are remarkable for being of different colours on the two sides. These are from Poona and Ahmednuggur.

Both calicoes and muslins, as well as woollen cloths, are employed by the natives to embroider, and some beautiful specimens in all the materials, and from different parts of India, have been sent to the Exhibition; and whether we examine one worked at Dacca or at Delhi, Madras or Mooltan, Cashmere or Khyrpoor, and whether in silk, silver or gold, we see great variety and taste displayed in the patterns, for even the most flowery or gorgeous are so kept within bounds as to appear never to exceed what is appropriate to the purpose for which the article is made. This we see equally in their woven as in their embroidered fabrics, as much in the rugs of Ellore and the carpets of Mirzapore and Gortekpore as in the shawls of Cashmere, and not more in the shawls than in the carpets of that far-famed valley.

India has long been famous for its steel, and the natives were early acquainted with the process of welding iron. Golden armour is frequently mentioned in the Rig Veda, that is 12 or 1400 years preceding the Christian era; and different parts of the country are famous for their works in copper and brass, as well as in silver and gold. As the natives employ the two first for the greater part of their cooking utensils, and the two last both for useful and ornamental purposes, there has always been a great demand for these different works in metals: all are remarkable for the goodness of their shape, whether made of copper or brass, or of the inlaid work, called Bidry.

There is great elegance in the silver service, inlaid with mosaic from Cashmere. The same elegance of form is seen in the rose-water sprinklers, or *goolabas*, which are employed to sprinkle rose-water over departing visitors. Much of the jewellery, though rich and handsome, is peculiar, because the tastes of the natives, and the modes of wearing it, differ from those of Europeans. A great variety as well of jewelled boxes have been sent by the Maha Rajahs of Nepal and Cashmere, and by the Rajahs of Rajpootana and of Cutch. The gold and silver girdles of Vizianagrum are as perfect in workmanship as the gold chain of Trichinopoly is elegant.

Dacca is one of the places celebrated for its silver filigree work; Cuttack and Agra are others: from all of which specimens have been sent. The articles usually made are bracelets, ear-rings, brooches, and chains; also groups of flowers, attardans, and small boxes for natives, of all of which beautiful specimens have been sent. Mr. Taylor says, the design best adapted for displaying the delicate work of filigree is that of a leaf. It should be drawn on stout paper, and of the exact size of the article intended to be made. The apparatus used in the art is exceedingly simple, consisting merely of a few small crucibles, a piece of bamboo for a blowpipe, small hammers for flattening the wire, and sets of forceps for intertwisting it.

The drawing of silver and gold wire, *i. e.* silver covered with gold (used as thread in embroidery), is extensively carried on at Dacca. Benares is also celebrated for the art. The preparations of the gold-wire for the fabrics of Boorhanpore has already been described at p. 920. There are several varieties of silver and gold thread (Badla) made at Dacca, as Goolabatooro for the embroidery of muslins and silks; Goshoo for caps and covering the handles of chowries; Sulmah for turbans, slippers, and hookah snakes; and Boolon for gold lace and brocades. Some of it is drawn as fine as a hair.

The beauty of form is still more conspicuous in much of their *Pottery*. Many of the forms are those which are most admired, as being of classical shapes. Some of the vases even look almost as if they were of Etruscan origin. There is no reason to believe that the natives have ever had anything but their own unerring taste to guide them, whether at Bhagulpore or Moradabad, at Kotah, Ashmedabad, or near Nagpore.

The natives of India having long been acquainted with a number of manufactures which are supposed to have originated in Europe, but of which there is no doubt that traces may be found at still earlier periods in the East. Some of these are of a chemical nature, as for instance, the crystallization of sugar and the manufacture of indigo, as well as that of gunpowder, of which several specimens were sent in the powder-flasks which accompanied many of the matchlocks, for which their country even now supplies the saltpetre for Europe. Red ink they obtain by the action of reagents on safflower, &c.; and black ink both by a process similar to our own, and by another which more nearly resembles that for printers' ink, which is better suited to their paper. Paper is another of the useful inventions which has long been known in the East. In India is made from a variety of materials, as from cotton, and of late years from plantain fibre. In Cashmere the fibre of hemp seems also to be employed, but throughout the Himalayas the pulp obtained from the fibre of *Daphne cannabina* is universally employed. With it have been made the large sheets of Nepal paper. The manufacture of leather seems also to have been long practised, and to have been used for making shoes and shields. The specimens which have been sent are of excellent quality; but these no doubt owe their peculiar qualities to European superintendence, as the leather from Calcutta was prepared by the Messrs. Teil, and that from Hoonsoon at the Government cattle establishment of that place. But Cashmere has been long famous for its leather; and Moorcroft, an excellent judge, describes it as "strong, solid, heavy, and pliable," and this without European aid, as in the case of the coloured specimens of leather from the Rao of Cutch. Glass-

making is another art with which they are acquainted, but in which they have made little or no progress, as the glass is discoloured and used only for bangles and small bottles. These are the chief articles of manufacture; but the author has succeeded in getting the glass-blowers of the north-west to make him very fair barometer and thermometer tubes out of broken European glass.

Dyeing is a strictly chemical art with which the Hindoos have been acquainted from very early periods, though no improvements appear to have been made in it for ages. Their country yields an abundance and a variety of raw materials as we have seen in the list of dyes; the mordants which they employ are chiefly alum and salts of iron, while the alkalies and acids which they likewise employ can be considered as useful only in changing the shades of colours. Calico-printing is universally acknowledged as being of Indian origin, and an art which was known to the Egyptians, as mentioned by Pliny, in a passage frequently quoted. Though the art has so greatly advanced in Europe, the Indian patterns still retain their own particular beauties and please multitudes of admirers, due no doubt, in a great measure, to the command which the natives of India have of colours, and the admirable taste with which they harmonise complicated patterns. Of some parts of the art, as for instance printing on gold, which has been only recently practised in Europe, some excellent specimens have been sent from Western India.

Having so early practised many of these arts, it is very remarkable that the Hindoos should for so many ages have remained satisfied with the progress they had made. This has been ascribed in a great measure to the distinction of castes, and to the political condition of the people. That they are capable of greatly improving in the different useful arts, is evident from the works which are turned out of the Government magazines and arsenals, and as may be seen in the accoutrements, and in the models of the artillery from the different Presidencies. The same thing may be seen in the teak-shipping built at Bombay. The saw-gins made in India are said to do their work as efficiently as those of England or of America. On the present occasion we have harness as well as boots from the Messrs. Monteith of Calcutta, which would do credit to any shop in London or Paris. So also the ropes made in imitation of those in use in Europe, as sent by Messrs. Harlon and Messrs. Thompson, from Calcutta. The neatness of their work may also be seen in the model of the crushing-machine sent by the Commissary-General of Madras, and the delicacy and accuracy of machinery made by their hands in the coin-sorting machine of Major Smith.

The Hindoos are remarkable not only for the exquisite skill which they display in the fabrication of the smaller works of fancy, but for the patience and resolution which they display in the excavation of their rock-cut temples, and for the beautiful polish which they have given to the surface of the hardest rocks. Dr. Kennedy has described the tools with which the Hindoo workman performs these works. They consist of a small steel chisel and of an iron mallet—"with such simple instruments they formed, fashioned, and scraped the granite rock which forms the tremendous fortress of Dowlatabad and excavated the wonderful caverns of Ellora; for it seems by no means probable that the Hindoo stone-cutters ever worked with any other tools." The mode in which they polish these masses of granite are the same in principle as has already been described as being practised by the stone-polishers of Cambay, pounded corundrum mixed with melted bees' wax being let into the hollow of a heavy block of granite, which is moved backwards and forwards until the required polish has been produced. We may be less surprised, therefore, with the polish given to the smaller articles of agate and cornelian, for which not only the workmen of Cambay but also of Cashmere have so long been distinguished. In the jewel-cases of the Indian department, we have some beautiful specimens from Lahore of crystal cups as well as agate boxes inlaid with precious stones. Baron Hugel states having seen in Cashmere a vase of

crystal which four men could scarcely lift. There could be no difficulty in carving in marble or other stone, but we cannot the less admire the beautiful patterns of the stone screens from Mirzapore. Such screens usually of marble are often used for surrounding the tombs in the old buildings of Agra and of Delhi. The skill in carving is equally displayed in softer materials, as in sandal-wood and ebony, and also in the black-wood (*Dalbergia latifolia*), of which so many specimens may be seen in the furniture made at Bombay. This skill is also displayed by the ivory-carvers of Berhampore, the shell-workers\* of Dacca, and in the horn-work of Vizagapatam and Viziadrong, and in that of the cocoa-nut at Tanjore, and still more in the delicacy with which the figures of the Rajah and Ranees of Travancore are produced, in so soft and yielding a material as pith.

The fine arts have hardly attained that excellence in India as to require much notice, except as connected with the objects within the limitations of the Exhibition. Painting has never attained to any excellence, though the natives are admirable delineators of some objects, as of natural history, which they can copy to a hair, without, however, any attention to perspective. The paintings on talc which are exhibited are interesting as exhibiting trades and costumes. Their sculpture, though employed in the representations of their gods and goddesses, has never succeeded in giving good views of the human figure; and yet they would seem capable of effecting much, for the models of the figures of the various castes are very successful in the variety of expression which they impart, and their success is great in the carving of some animals; as, for instance, in the head of the elephant in ivory, from Berhampore; also in the stone figures of the elephant, rhinoceros, and sacred ox. Their stone, wood, and ivory carving might even be considered as coming within this section of the fine arts, from the beauty of the patterns and the elegance of effect which is produced.

Engraving on gems has long been practised in the East, and with great success, as far as ornamented letters are concerned. Of these there are some favourable specimens from Delhi; and from Madras, we have stones engraved, representations of a lighthouse, and monuments.

The mosaics from Agra, as shown in the marble chess-table inlaid with agates, as well as in inkstands, card-trays, &c., are favourable specimens of the art. Though it is sometimes said that this art may have been introduced into Agra from Italy, it is not more elegant in pattern than the inlaid work, for which the metal-work called "bidry," is conspicuous, and for which the inlaid silver service and bedstead from Cashmere is so remarkable. This beauty of pattern, so conspicuous in the shawls of Cashmere, is also displayed with remarkable taste in the several boxes and pen-and-ink trays from the same part of India.

Architecture is at least one of the fine arts in which the Hindoos have excelled, as their style is their own, and the effects which they produce peculiar and striking, and this whether we examine the carved temples of Ellora, or the pagodas of the Peninsula; of these, the pith models are the only representatives in the Exhibition. The models which are exhibited from Benares and Mirzapore show the ordinary form of the temples in the valley of the Ganges, while the models of the Musjid or mosque and Hindoo temple from Ahmedabad show a different style of architecture.

From the very cursory view which we have taken of the arts of India, we cannot but allow that the natives of that country, with but simple means and their unassisted efforts, have produced works which we cannot but admire, even after wandering in all the courts of the Crystal Palace dedicated to the arts of Europe; and, if we doubt our own judgments, we may refer to the numerous artists

\* "The manufacture of shell bracelets is one of the indigenous arts of Bengal, in which the caste of Sankari at Dacca excel. The *chanks* of which they are made are large convolute shells (*Voluta granis*, Linn.), from six to seven inches long, and of a pure white colour. They are imported into Calcutta from Rannad and Southern India, opposite to Ceylon, and from the Maldivé Islands."

who may daily be seen employed in drawing and studying the works of a people whom many consider as placed beyond the pale of civilization, but among whom we may see the practice of many useful arts, which we sometimes fancy our own, because the Moors introduced them into Europe; and we may observe, also, the germs of some discoveries which we know have only recently been matured in Europe, though we have no means of judging whether the idea may not, in some instances, have come from the East.

We cannot do better than conclude, therefore, these hastily-written observations on the arts and manufactures of India, in one of the mottoes of the Official Catalogue—"SAY NOT THE DISCOVERIES WE MAKE ARE OUR OWN: THE GERMS OF EVERY ART ARE IMPLANTED WITHIN US, AND GOD, OUR INSTRUCTOR, FROM HIDDEN SOURCES, DEVELOPS THE FACULTIES OF INVENTION."

## CEYLON.

### NORTH AREAS, I. J. 31.

#### COLLECTION OF NATURAL PRODUCTIONS and MANUFACTURES of the ISLAND of CEYLON:—

Rock Crystal. Iron and common quartz. Amethyst. Garnet. Cinnamon stone. Harmotome. Hornblende. Hypersthene. Common corundum.

Ruby. Chrysoberyl. Zircon. Mica. Adularia. Common felspar. Green felspar. Albite. Chlorite. Pinite. Black Tourmaline. Calc-spar. Bitterspar. Apatite. Fluorspar. Chialolite.

Iron pyrites; magnetic iron pyrites. Brown iron ore. Spathic iron ore. Magnetic iron ore. Titaniferous iron ore. Ironglance. Manganese. Molybdenglance.

Tin ore. Arseniate of Nickel. Plumbago. Epistilbite. Gadolinite. Wolfram. Crichtonite. Ilmenite. Pyrochlor. Binnerite. Ceylonite. Cabook. Kaolin.

[The geology of Ceylon is imperfectly known in detail, but it appears that various porphyritic rocks and gneiss chiefly prevail, the latter covering the largest area, but the former exhibiting many very interesting varieties. Sandstone occurs to some extent, and some calcareous rocks and dolomite have also been described.

The mineral produce of the island is somewhat varied and of considerable value, and many of the minerals mentioned above are of considerable interest. Of the metals, iron and manganese abound, while several gems (cat's-eye, ruby, and sapphire), plumbago, salt, and nitre, are also important sources of profitable trade. There are several hermal mineral springs, considered valuable for medical purposes.

Some varieties of precious corundum of considerable value have been found in Ceylon, but Pegu is their chief locality. The Ceylon plumbago is soft, but remarkably pure. The salt exists in natural deposits, and is an important source of revenue. Nitre is found in caverns, and is widely distributed. Of the various minerals mentioned above, *Gadolinite* contains the rare earths yttria and glucina, and *Pyochlore*, the equally rare substances, columbium, cerium, and thorium. *Cabook* is a reddish loam, resulting from the decomposition of clay iron-stone.—D. T. A.]

GREY, The Countess.

A gilt sprinkler under a glass shade, from Ceylon.

ALBRECHT, GREENHILL, & Co.

Cinnamon and cinnamon oil.

Cocoa-nuts, from the South and West Province. Rice, general. Arrow-root, from the South Province. Manioca, from the West and South Province. Hill paddy, from the Central Province. Curugan, general. Maize, from the



South and Central Province. Millet and Timne, from the same.

Coffee, from the Central Province, chiefly. Cardamoms, from the Four Korles, Galle.

Cinnamon, from the Western Province.

Tobacco, from Jaffna, Negombo, Tangalle. Ginger and nutmegs from the Western Province. Yams and sweet potatoes. Talipot leaves, from the Central Province.

Cocoa-nut sugar, from Batticaloa; Palmyra sugar, from Jaffna; Cane sugar, from the Western Province.

Manioca flour, from the West and South Province. Arrow-root flour, from the Southern Province. Sago, from the Northern Province. Vinegar.

Cotton, native, Bourbon and Sea Island; from Batticaloa and Jaffna.

Coir fibre, from the South and West Province.

Gambose and tamarinds, from the West and East Province.

Areca nuts, from Four Korles.

[The areca nuts mentioned are yielded by a palm, and are highly esteemed by the natives of the East. They prove a not unimportant article of commerce, and one also employed, to a small extent, in the arts. But they are principally valued for a sort of inebriating property which they possess, and which is perceived in chewing them. Those who become addicted to this habit, which is almost universal, are passionately attached to the use of these nuts.—R. E.]

Copperah, from the East and West Province. (Copperah is the dried kernel of the cocoa-nut, which abounds in the South.)

Timber, general. Clearing Nut, from the North West and East Province.

Aloe fibre, cardamum, plantain, and hibiscus fibre, from Kandy and Colombo.

[The bark of several species of *Hibiscus* is so tenacious as to yield a serviceable material for textile purposes. For the manufacture of a coarse kind of cordage it is considerably employed, and the fibre is likewise used for making a coarse description of sacking. The *Hibiscus* belongs to the Malvaceous variety of plants.—R. E.]

Ivory and buffalo horns, from the North and East Province. Deer horns, from the Central and North Province.

Birds' nests, from Pasdoom Korle.

Honey and wax, from Bintenne.

Hides and hoofs, from Colombo.

Musk, from the Northern Province.

Chay, a root, or Indian madder, from the Northern Provinces.

Jack and malille, or halmalille woods, general.

Sappan wood, from the West, South, and East Provinces.

Turmeric and myrobolans, from the East Coast.

[The turmeric of commerce is yielded by a plant belonging to the natural order *Zingiberaceæ*, and botanically called *Curcuma longa*. It is largely used in the preparation of various condiments, and also for dyeing. It has likewise medicinal properties. The analytical chemist is accustomed to prepare slight testings for alkalis by the aid of paper coloured with turmeric, the change of colour affording him the information he requires.—R. E.]

Pearls, Arcjso.

Chalks, from the Northern Province. Jaffna moss, from Calpentyn.

Sponges and cowries from Jaffna and Trincomalee.

Salt from Chelaw and Hambautotte.

Beche de mer, from the Northern Province.

[Beche de Mer is a radiated animal of the Holothuria tribe.]

Oils: cocoa nut, purified, cinnamon, clove, citron,

lemon grass, and cajeputi, from Colombo, Galle. Margosa oil, from Kandy. Croton and castor oils, from Colombo. Kekuna and gingelly oils, from Kandy. Citronella, meemel, and spearmint oils, from Galle. Mee oil, from Colombo.

Models of carriages and palanquins, from Colombo.

Chekoos, from the Western Province.

Looms; stills (medical), from the North, North West, and South Provinces.

Forges; smelting furnaces, from the Central and South Provinces.

Models of boats; guns; weapons, general, Kandy, &c.

Agricultural tools.

Cotton fabrics, plain and dyed, from the North, East, and South Provinces.

Cotton fabrics, painted, from Kandy.

Lace, from Galle.

Cutlery, general.

Gold and silver ornaments, from Kandy, Jaffna, Galle, &c. Crockery, plain and painted; and four toms, from Kandy and Matura.

Matting, from Kandy and Caltura.

Coir cordage, from the Southern Provinces. Coir webbing and bagging, from the Southern and Northern Provinces.

[Among the almost innumerable uses to which the cocoa-nut palm, *Cocos nucifera*, has been applied, that of yielding a fibre for the production of cordage is not the least important. This fibre, called *coir*, is obtained from the rind of the nut. It is manufactured, on an extensive scale, into cordage, webbing, bagging, &c., and possesses certain properties which practically fit it for this purpose. Being little acted on by water, and at the same time extremely tenacious, the rope made of it is valuable for maritime purposes. The fibre is too coarse for any of the finer textile purposes.—R. E.]

Aloe bagging, from Kandy. Hibiscus bagging, and cordage. Sanserira bagging, from Colombo.

[The Sanserira bagging is obtained from the fibre of a hibiaceous perennial plant, abundant in tropical Africa and India generally. The fibre is extremely tough, and answers for the manufacture of coarse materials, such as that described. Several other plants of the same order are found to yield a useful fibre for textile purposes.—R. E.]

Tortoiseshell and Chank ornaments, from Kandy, Matura, and Galle. Fishing lines and nets.

Baskets and boxes; quill, deer horn, buffalo horn, and straw, from Caltura and Galle.

Kandy painted baskets and boxes; umbrellas; punkahs, from Kandy.

Ornamented olas soap, from Kandy and Matura, Galle.

Carved work, ebony, from Galle and Caltura; ivory, from Four Korles; woods, from Galle and Caltura; steel, from the Central Provinces; cocoa-nut shells, from Galle; and egg shells, Kandy.

Models of Temples, from Colombo.

PARLETT, O'HALLORAN, & Co., Colombo.

Specimens of cinnamon, with essential oils extracted therefrom; with implements for cutting and peeling.

An ebony table, inlaid with fifty different woods; a fair specimen of Cingalese cabinet-work.

Model of coffee-works and apparatus used in Ceylon.

Model of patent stove and apparatus for curing coffee, by M. Clerihew, of Rathnagon.

Thirty specimens of medicinal oils, from T. A. Pieris, of Kandy.

Guns and resins from T. A. Pieris, of Kandy.

Forty specimens of ornamental and house-building timber.

Desk of porcupine quills. Ebony-carved flower vase.

Painted ivory fan-handle.

Buffalo horns mounted in silver.

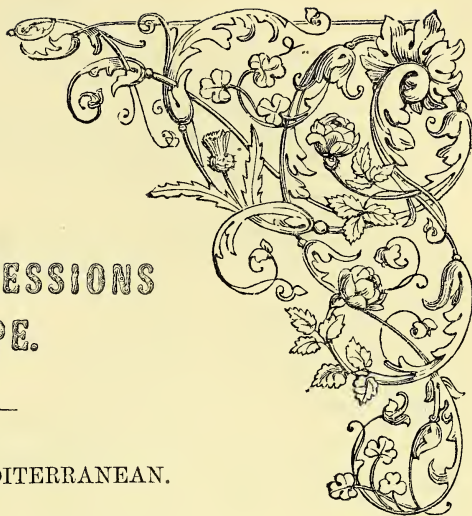

## II.

# BRITISH POSSESSIONS IN EUROPE.

### CHANNEL ISLANDS.—MEDITERRANEAN.

For special information on the general characteristics of the contributions forwarded by different places coming under this head, reference will be made to the commencement of each. A short prefatory notice is intended to furnish a sketch in outline of these, and is attached to each separate catalogue. The dependencies included under this head are in numerical order—the Channel Islands, Malta, and the Ionian Islands.—R. E.

#### CHANNEL ISLANDS.

NORTH SIDE, I. J. 30.

*Commissioners*—Captain W. WALBANKE CHILDERS, *Terrace House, St. Helier, Jersey*, and THOMAS CLUGAS, jun., Esq., *New Grand Terrace, Guernsey*.

THE Channel Islands, which are represented in the Exhibition by nearly fifty exhibitors from Jersey and Guernsey, have supplied an interesting and characteristic collection of articles in the various classes. The geological character of this group, which belongs to the primary rocks exclusively, is indicated by a collection in Class I. of the granites and other rocks of that series entering into the formation of the islands. These rocks are extensively quarried for building purposes, and the granite and syenite, particularly the latter, are highly valued and possess a fine grain. Several of the streets of the metropolis are paved with granite from these islands, and monuments have been erected from some of the finest varieties. The islands are remarkable as containing no fossil remains, nor any of the derivative rocks properly so considered. The fertility of the soil is indicated by a collection of wheats grown in Jersey, and arranged with considerable care; and the important element in the adaptation of the soil to the requirements of the farmer—manure—is also shown, and consists of the burnt and fused ashes of marine plants. These plants are called by the inhabitants "vraic," and are collected at stated periods. They contain, when burnt, a large proportion of iodine, and are useful as a manure from their other saline and earthy ingredients. Specimens of iodine obtained from vraic are exhibited. Specimens of silk reared in Guernsey are interesting, as suggesting attention to an important and probably ultimately a profitable direction for the employment of capital. Knitted articles of various kinds indicate the constant employment of the peasant women of these islands. A large sideboard of native oak, chiefly with carving repre-

senting the signing of Magna Charta, will receive notice. The natural history of the islands is represented by a collection of specimens of conchology. The shell-beaches of the beautiful island of Herm form the source of a great variety of species, and are the resort of every naturalist visiting these islands. The shells are formed into a number of ornamented articles, of which some are exhibited. The natural history of these islands is, in many respects, as in the case of other insulated spots, peculiar; but it is to the results of industry of some of the inhabitants that this Catalogue chiefly refers.—R. E.

#### 1 WHITE, HENRY CAMPBELL, F.G.S., *Regent Road, Jersey.*

Geological specimens of the granites of Jersey, arranged by order of the local committee. Syenite from Mount Mado and La Brugne, St. John's Parish; St. Mary's, St. Breade, St. Clement, St. Aubin; Booley Bay, Trinity; and Verclut, St. Ouen; conglomerate, St. Catharine.

[The syenitic rocks, which are quarried chiefly at Mount St. Mado, in St. John's parish, Jersey, are commercially valuable. The other rocks, and particularly the conglomerate from St. Catherine's Bay, are interesting only to the naturalist and geologist. No traces of any metals, with the exception of iron, have been observed in Jersey, and the slates of the schistose rocks have not been used for economical purposes. The peculiar rigidity and wildness of outline of the rocks of the primary series is strikingly exemplified around the coast. Fantastic rocks of every form appear above the waters, and the steep cliffs of the northern shore are frequently hollowed into chasms and caverns. Notwithstanding the force and velocity of the tidal current around these islands, but little impression appears to be made upon them even by the roll of the Atlantic, the waves of which, when provoked by south-westerly winds, beat impetuously upon the coast.—R. E.]

2 LE COUTEUR, Col. JOHN, *Belle Vue, Jersey*—  
Producer.

Specimens and notes of produce of some of the most approved varieties of wheat cultivated in Great Britain, Jersey, &c., arranged by J. Le Couteur, F.R.S., M.S.A., Aïde-de-Camp to Her Majesty the Queen.

White winter wheat.

*Var. No. 1. Triticum Hibernum Hybridum Candidum Epulonum Leucospermum of La Gasca, ex-Curator Royal, Gardens, Madrid.*

1. Dantzie (Jersey). See grain. 52 imperial bushels to the acre.
2. Chidham. 1838.—18 lbs. of flour produced 26 lbs. 4 oz. of excellent white bread. Nature dry.
3. Berkshire.
4. Lewin's Eclipse.
5. Clutton.
6. Whittington. 1841.—27 lbs. of flour produced 37 lbs. of good bread, rather brown. Keeps moist.
7. Brown Chevalier. 27 lbs. produced 35 lbs. 14 oz. excellent white bread.
8. Canada.
9. Burrill, from Earl Spencer. 1842.—27 lbs. of flour produced 36 lbs. white bread.

Winter compact varieties (Fr. *Froments carrés*; Ger. *Vierzeilige Weizen*).

*Var. No. 2. Trit. Hib. Album Densum, of La Gasca.*

1. Jersey Pearl. 48 bushels to the acre. 18 lbs. of flour produced 24 lbs. of bread, white, dry nature. 1837.
2. Ducksbill, Kiel. 1836.—18 lbs of flour produced 24 lbs. of bread, rather moist.
3. Britannia.
4. Buckland Toussaint, Devon.
5. Suffolk Thickset.
6. Mazzochino, Italy.
7. Buff Surrey.

*Var. No. 3. Elongated winter wheat (Fr. *Froments alongés*; Ger. *Weizen Verlangen*).*

*Trit. Hib. Candidissimum Epulonum of La Gasca.*

1. Dantzie, Jersey. See Grain, High-mixed, of commerce. 27 lbs. of flour produced 35½ lbs. of excellent white bread.
2. Cape of Good Hope, longest.
3. Cape of Good Hope. 1840.—27 lbs. of flour produced 37 lbs. 8 oz. of white moist bread.
4. Malaga.

*Var. No. 4. Downy, or hoary wheat (Fr. *Veloutés*; Ger. *Wollige Weizen*).*

*Trit. Hib. Koeleri of La Gasca.*

1. Kentish Downy. See Grain, B. V. 55 bushels to the acre. 18 lbs. flour produced 26 lbs. of bread, excellent quality.
2. Guinea, Norfolk.
3. Turgidum.
4. Imperial Buff.
5. Tunstall rough chaff.
6. Italian.

*Var. No. 5. Red wheats (Fr. *Froments Rouges*; Ger. *Rath Weizen*). Trit. Hib. Glabrum Rufum of La Gasca.*

1. Golden Drop. See Grain.
2. Red Hair Welsh.
3. Rattling Jack.
4. Old Red Norfolk.
5. New Red Norfolk.
6. Old Red Lammus.
7. Britannia.
8. Red Chaff Dantzie.
9. Blood-red Scotch.
10. Syer's.
11. York Square-headed.
12. Copdock.
13. Golden Prolific.
14. Red Burrill.

*Var. No. 6. Spring wheats (Fr. *Bleds de Mars Trémois*;*

10. Hardcastle.
11. Old Essex.
12. Pegglesham.
13. Ten-rowed Prolific.
14. Old Suffolk.
15. Earl Tolham.
16. White Dantzie, Lincoln.
17. Old Lammus Prize, Devon.
18. Dantzie, Oxford.
19. Old Welsh white Lemon.
20. Mullybrack, Norfolk.
21. Pears, Scotland.
22. French.
23. London Superior.
24. Royal Standard.
25. Baltic. 18 lbs. of flour produced 23 lbs. of bread.
26. Kentish long.

8. Chili. 1848.—27 lbs. of flour produced 34 lbs. 12 ozs. brown heavy bread. Condemned, after seven years of trial, though suited to the stormy regions of the mountains of Chili.
9. Cape of Good Hope.
10. Coturianum Compactum, La Gasca. 58 bushels to the acre. 27 lbs. of flour produced 36 lbs. 2 ozs. white bread, of a moist nature.

7. Van Diemen's Land.
8. Crim Tartary.
9. Var. High-mixed, Dantzie.
7. Coturianum Confertum of La Gasca.
8. Red-grained.
9. Chili, 1850—to be tried.
10. Jersey, 20 lbs. 6 ozs. of this flour, and 6 lbs. 10 ozs. of bran, produced 39 lbs. 1 oz. of good bread, second quality.

15. Essex.
16. Prolific.
17. Sark, very hardy.
18. White Golden Drop.
19. Gigantic.
20. Grand Rubella.
21. Compact Red.
22. Kiel.
23. Cape of Good Hope. 1840.—18 lbs. of flour produced 26 lbs. 6 ozs. of brown bread, of a dry nature.
24. Pale red Cape.

Ger. *Springen Weizen*). Triticum *Æstivum Candidum Epulonum of La Gasca. Beardless (Sans barbes).*

1. Belle Vue Talavera (Col. Le Couteur's Seedling). See Grain. 1838.—52 bushels to the acre. 1841.—27 lbs. of flour produced 35 lbs. 14 ozs. bread of the finest quality.
2. Old proved Talavera, Spain.
3. Malaga.
4. Italian.

5. Cape White. 1840.—27 lbs. flour produced 37½ lbs. white moist bread.

6. Mummy. Tombs of the Kings of Thebes. Sir Gardner Wilkinson. Raised at Belle Vue, from one ear, sent by M. Tupper, Esq., 1846.—27 lbs. flour produced 35 lbs. bread. Very light, white, superior.

*Var. No. 7. Bearded (Fr. *Bleds-trémois barbus*; Ger. *Bartweizen*).*

1. White Lily (Jersey). See Grain. 27 lbs. flour produced 38½ lbs. bread. Moist, white, superior.
2. Horned Red grain, Lincoln.
3. Brittany.
4. April.
5. Arthur's Jersey (hardy, and productive on poor soils).
6. Black-jointed. 1841.—27 lbs. flour produced 37 lbs. of good bread.
7. Old White-hair Welsh.

8. Old Red-hair Welsh.
9. Rivets.
10. Coetbo, Brittany, elongated.
11. Coetbo, ,, compact.
12. Spanish.
13. Victoria, Caraccas.
14. Kubanka of commerce.
15. Cape of Good Hope.
16. Italian Red.
17. Kiel, Baltic.
18. Italy.
19. Egyptian.

Total, 104 specimens.

*Comparison and Result.*

The Kentish or Jersey Downy Wheat:—In 1847, one quarter, or 463½ lbs., produced 351½ lbs. of flour, which produced 482½ lbs. of bread.

Baltic or Rostock Wheat:—In 1847, 454 lbs. of wheat produced 312 lbs. of flour, which produced 398½ lbs. of bread.

Downy, 482½ lbs.

Rostock, 398½ „

or 84 lbs. excess over the Rostock on one quarter; or excess over one acre, at 6 qrs. to the acre, 504 lbs. of bread—the supply of one person for a year. The excess over some inferior varieties, as to quantity of produce and yield of flour, being far greater.

Those varieties, to which explanations have been given, have all been tried by the exhibitor at Belle Vue.

[The agricultural productions of Jersey are wheat, barley, and oats: parsnips are grown; and potatoes for exportation are extensively and increasingly cultivated. For a series of years the present exhibitor has been occupied in classifying and arranging the varieties of wheat; and the facts developed by his experiments appear to give a high degree of fertility of soil to that of Jersey over the soil of other places. The uniformly mild and genial temperature of these islands generally forms undoubtedly a great element in the success which attends the labours of the agriculturist, and particularly of the horticulturist and florist.—R. E.]

3 DUNLEVIE, Mrs., *Belmont Place.*

A richly knit silk purse: worked by a lady 83 years of age.

4 BERLAND, J., *Great Union Road.*

A machine to stop railway carriages instantaneously.

5 LE MOYNE, HENRY, *St. Helier, Jersey*—Inventor.

Diagrams to elucidate the method of trisecting any angle. These diagrams are the exhibitor's invention.

[The trisection of an angle by plane geometry is a problem as impossible as the quadrature or rectification of the circle.—R. W.]

6 CHEVALIER, JOHN, *Don Street*—Inventor.

Model of a swinging beacon, for the prevention of shipwrecks, by marking the situation of rocks. Not liable to be damaged, or carried away by sea or shipping.

[The sea all around these islands is beset with rocks



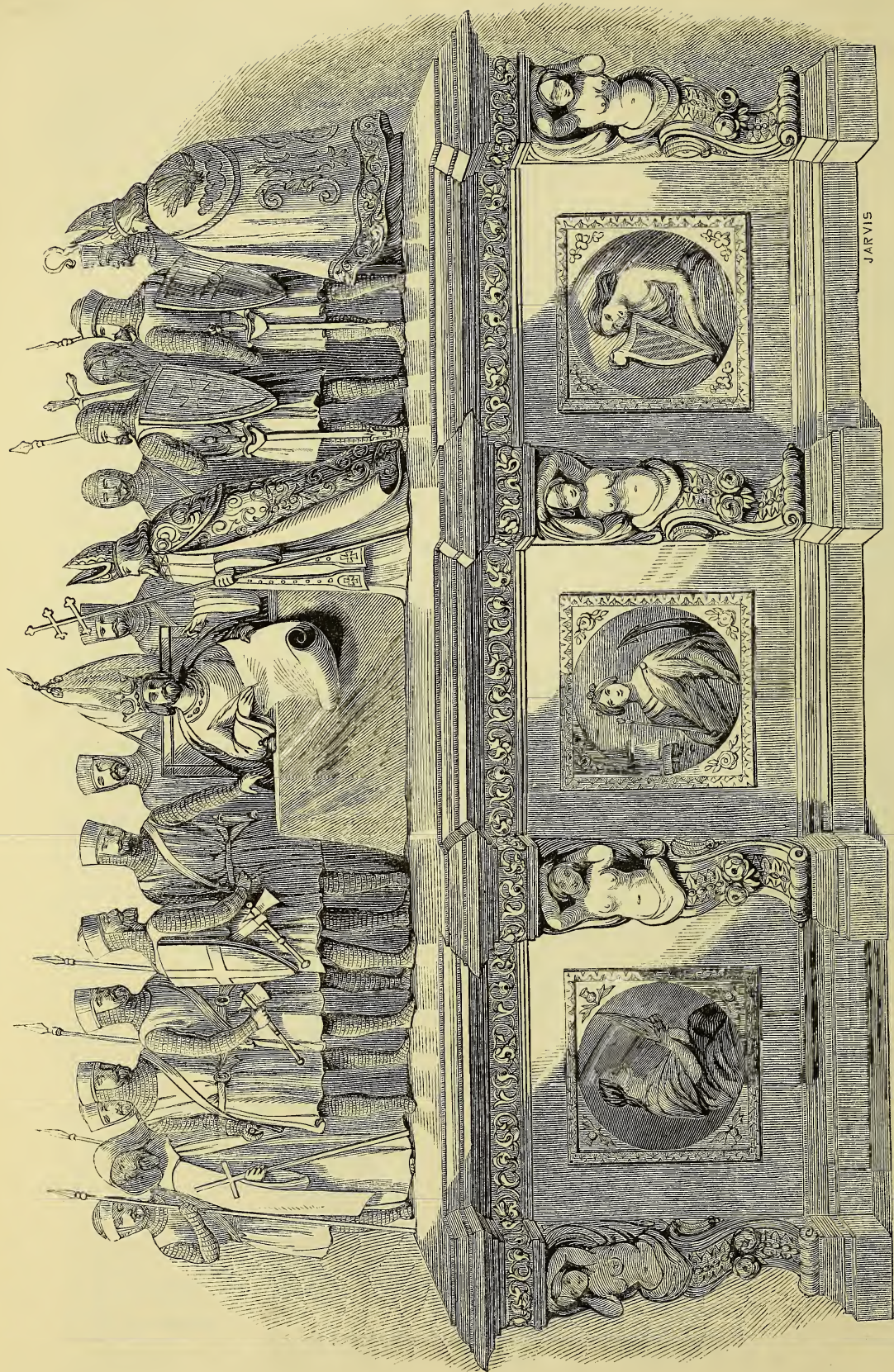

JARVIS

SIDEBOARD OF CARVED WAINSCOT, REPRESENTING KING JOHN SIGNING MAGNA CHARTA. G. C. LE FEUVRE, JERSEY.

upon which fearful shipwrecks have taken place, attended with great loss of life. Beacons of various kinds are placed upon them; but these are often of little avail, in consequence of the dense fogs which at times fill the Channel. An exhibitor in a preceding Class has recommended the adoption on some of these rocks of a light-house of brass, the dome of which might be converted into a great bell, which might be struck during thick weather.—R. E.]

7 DE LA CONDE, M., *Broad Street*—Manufacturer.

Specimens of artificial teeth, of novel construction, and with double hinges.

8 FELTHAM, R. D., 1 *Oxford Place, St. Marks, Jersey*  
—Inventor.

Spring skeleton regulator; will go without winding-up for 500 days: its peculiar novelty consists in the adaptation of a pendulum making but one complete vibration in sixteen seconds, with detached escapement; its execution is considered to be superior, from the combination of its motive power.

[The direction of the going of a clock without winding depends principally upon the increase of the weight employed to move it. By the introduction of several wheels, and the employment of a proportionate power in the weight or springs, the ordinary going period may be greatly prolonged; ordinarily, advantage is found from the less occasional necessity for winding up.—R. E.]

9 DUPRÉ, W. H., *Charing Cross, Jersey*—Inventor.

Defiance wind guard, for the prevention of down-draught, or the descent of smoke in chimneys. The outer pipes surrounding the stem are formed in a spiral direction from the base to the top.—Patented.

Another for the same purpose, adapted for any situation, whether surrounded by hills, or tall buildings.

Roof light of glass, in a zinc case; it allows ventilation and light, without leakage.

10 LE FEUVRE, PHILIP, *St. Clement Academy*—  
Inventor.

Orrery, for school use. This orrery shows the moon's motion round the earth, her daily variations, her position at the time of new and full moon; also, the cause of eclipses, and whether partial or total: the phases of the moon are indicated by cones constructed of pasteboard attached to the earth and moon.

11 LE FEUVRE, Mrs. F., *Edward Place*—Producer.

A fire-screen, worked in tapestry by the exhibitor.

12 WHITE, GEORGE, *St. Mark School, Jersey*—  
Proprietor.

Class box and illustration board, to exhibit writing, &c., to a class in a school, used as a seat and box for books.

Door governor: to prevent violent shutting.

Chimney-pots or ventilators; to prevent "down-draught," by hills or buildings, having the advantages of an open chimney-pot combined with a covered one. "Down-draught" caused by adjacent obstructions made to assist the upward draft by confluence with it.—Registered.

Illuminated clock: to show the hour after dark by light transmitted from a central chamber to the interior of the pointers, which, having transparent fronts, show luminous lines on the darkened dial; the figures are also lighted from the same chamber.

Pump and blower, for the conveyance of water or air. The general arrangement for giving motion is by centrifugal force.

13 BROHIER, HENRY, *New Street, Jersey*.—Proprietor.

Specimens of Jersey knitting, by an old lady; viz.—knitted garment, commonly known as "Guernsey frock," of white worsted. Pair of drawers, also knitted, of coarse grey worsted, undyed.

14 DE FAYE, THOMAS, *Seale Street, Jersey*.—  
Proprietor.

Twelve pairs of beautifully knit stockings. Knitting peculiar to the island; fine woollen thread, dyed of different colours.

[The female peasantry of Jersey are seldom if ever without the materials necessary for this occupation. On the way to or from market, and at other times, knitting forms their almost constant employment; and the articles produced have a peculiar character, which renders them readily recognisable.]

15 VIBERT, SUSANNA, *St. Mary, Jersey*—Manufacturer.

A pair of knit stockings, the work of the exhibitor, aged 71 years; the peculiar manufacture of Jersey.

16 MARIE, MARY, *King Street*—Manufacturer.

Richly knitted silk jacket, in blue and white stripes, having on the breast the Prince of Wales' feather, and under it the words "Albert Prince de Galles." Knitted entirely by the exhibitor, who is a shoebinder; it contains upwards of one million stitches.

17 SCARFE, GEORGE, *Beresford Street*—Proprietor.

Chaise harness, elegantly fitted with silver ornaments, and elaborately finished and embossed.

18 CARMALT, JOHN, *David Place*—Manufacturer.

A pair of scissors and a knife, so diminutive in size that the two do not weigh a grain.

19 JOUHAUD, PETER, *Peter Street*—Inventor and  
Manufacturer.

Carriage-gun: takes readily to pieces, and can be used as a rifle, a fowling-piece, or a pistol; cannot be discharged by accident, having a secret spring; is embossed and inlaid with gold and silver. The lock is of a peculiar construction; the stock is finely carved.

20 LE FEUVRE, GEORGE CLEMENT, *Edward Place*—  
Manufacturer.

Chiffonnière, composed of oak, a portion the produce of the island of Jersey; the inside fittings of satin-wood; the panels tapestry. There are three compartments, cabinet, secretary, and boudoir, the latter containing a nest of drawers. The ebony and satin-wood fittings are beautifully finished. The panels represent the emblems of England, Scotland, and Ireland in tapestry, the work of the exhibitor's wife, divided by carved columns, with figures surmounted by wrought frieze. The back represents, in carved work, King John signing the Magna Charta. The accompanying Plate 94 represents this sideboard.

21 STEAD, WILLIAM, *Hill Street*—Manufacturer.

A piece of furniture, applicable as a celleret or font; the bowl, cut out of solid mahogany, is finely carved, and supported on three claw-feet; the top is movable by ropes and pulleys, running in circular boxes forming the pillars or supports for the crown by which it is surmounted, and resting on the edge of the bowl on three worked lions' heads.

22 COLLIE WILLIAM, *Belmont House, St. Helier, Jersey*—Producer.

Calotype pictures from life—"French and Jersey Market-women."

[Preceding notes, in Classes of the United Kingdom, have explained the use of this term calotype—originally a

derivative from the Greek. It is now generally superseded by that of Talbotype, implying the name of the inventor of the art of photography on paper. The peculiar brilliancy of the atmosphere of these islands, combined with the abundance of blue light reflected from the sea, was found by the writer to communicate an almost instantaneous impression to paper or plates.—R. E.]

23 SAUNDERS, GEORGE, *Bath Street, Jersey*—Producer.

A model in paper, representing Her Majesty landing at Victoria Pier, Jersey, 3rd September, 1846.

[The Victoria Pier at Jersey is only just approaching its completion, and has absorbed a large amount of time and money. It is protected by Elizabeth Castle on the northern side, and covered by the guns of the fortress which commands the town.—R. E.]

24 SIMON, Miss, *Elizabeth Place*—Proprietor.

Basket-work, in paper; an heirloom from her progenitor, Madame Mauger, in 1728.

25 CLUGAS, THOMAS, jun., *8 L'Hyvreuse Terrace, Guernsey*—Proprietor.

Specimens of granite, porphyry, and pot-stone, from the islands of Guernsey, Herm, and Sark:—

1. Porphyritic gneiss, from Pleimont Cliffs.
2. Red porphyritic gneiss, from the same.
3. Black hornblende, from les Teilles.
4. Hornblende schist, from Castel au Roc.
5. Red Syenite, from Roc de Guet.
6. Grey Syenite, from Mont Cuet.
7. Blue Syenite, from the Vale quarries.
8. Grey Syenite, from the island of Herm.
9. Porphyry (black), from the island of Sark.
10. Steatite, from the same island.

Carved specimens.

The above are used for building and macadamizing. Herm syenite was used for the steps of the Duke of York's Column, in Waterloo-place.

[The rocks of Guernsey are principally gneiss, granite, and syenite. Quarries of syenite exist at Grande Roque; but this syenite is not considered equal to that of Mount St. Mado, in Jersey. At St. Sampson's are some extensive quarries of granite, which are worked for paving-stones; and of these considerable quantities are sent to London and Portsmouth. Experiments made as to the comparative durability of this granite and other granites, give a result highly favourable to its employment. It has been successfully laid down in the heaviest thoroughfare in the metropolis. Quarries formerly existed at the island of Herm, but are now abandoned. In the same island, and in Sark, are several mines, which formerly yielded copper and silver in considerable quantities; but these are now no longer worked.—R. E.]

26 MARTIN, PETER, *St. Peter's Port, Guernsey*—Producer.

Raw silk, the produce of the Island of Guernsey, being the first sample obtained by the Guernsey Silk Growers' Company, lately established in the island.

Arrowroot fecula, obtained from the *Arum maculatum*, a plant indigenous to Guernsey.

[Experiments have been repeatedly made in England to introduce the culture of the silkworm. The late Mrs. Whitby was very successful in this art, and laboured much to establish it in this country: her experiments show that the mulberry of the Philippine variety, *Morus multicaulis*, is best adapted for their food. The culture of this insect, and the introduction of this tree into the Channel Islands, would very probably be attended with a large success if carefully carried out. The almost total

absence of frost in winter is sufficient to indicate the great mildness of the climate.—R. E.]

27 ALLÉOND, EMANUEL, *St. Peter's Port, Guernsey*—Inventor.

Model of a machine to determine the distance run by a ship, and at the same time to determine the ship's place on the chart.

28 HARRIS, PETER GEORGE—Inventor.

A corking machine: improved application of the lever in driving the cork through a cone, the bottle being secured by another lever at the foot.

29 MACDONALD, SOPHIA, *Woodland*—Inventor, Designer, and Manufacturer.

Tulle dress, embroidered with groups of floss silk flowers, copied from natural flowers. The novelty consists in the firmness given to the floss silk flowers on so slight a texture as tulle.

30 DOBREE, HARRIET, *De Beauvoir*—Designer and Inventor.

Table-top, ornamented with shells found in the Island of Herm.

Group of poultry made of shells.

[On the western and northern shores of the island of Herm there exist interesting shell-beaches, which afford a rich study to the conchologist. It is remarkable that on this small island, of the entire group, is this collection of shells chiefly found. They are principally of a minute, and often almost microscopic size; but their numbers are inconceivable.—R. E.]

31 HUTCHINSON, ELIZABETH, *Queen's Road*—Designer, Inventor, and Manufacturer.

Vases, with shell flowers.

Octagon table slabs in rosewood cases, with groups and wreaths of shell flowers.

32 SARCHET, JOHN, *Victoria Road*—Inventor.

Model of a machine for welding chain cable and other links, the first invented; saving labour, and of importance for ship cables.

33 ARNOLD, ADOLPHUS, *11 Commercial Arcade, Guernsey*—Manufacturer.

Specimens illustrating the manufacture of iodine and iodide of potassium.

Specimens of the fuci and algæ which grow abundantly on the north and west coasts of the island of Guernsey.

Fused mass, consisting of the ashes of these marine plants, and containing salts of soda, potash, lime, and magnesia. The quantity of iodine in this material bearing a direct ratio to the quantity of potash contained therein, it is presumed to exist as iodide of potassium.

Iodine in the rough state, as produced in the first receiver connected with the distillatory apparatus, and containing bromine and chlorine in small proportions.

Commercial iodine, prepared by steam distillation, pure, dry, of brilliant metallic appearance, and free from bromine. Used in medicine and the arts for dyeing.

Crystals of iodide of potassium, prepared from the preceding.

Residuary product, consisting of the ashes of the fuci and algæ, after the iodine has been extracted, and containing the salts of potash, soda, lime, and magnesia, as chlorides and sulphates. Used as a manure by the farmers.

[The collection of the fuci and algæ which abound in the northern, western, and south-western shores of Guernsey, is considered of great importance by the island agriculturist. The "vraic" is gathered at spring tides, and the event is one of peculiar interest, in consequence of the

crowds of people employed in cutting, carting, and removing the marine plants. *Vraic* is distinguished into the cut and the floating sorts; the former is most highly valued, and the gathering of them is protected by law. Between 25,000 and 30,000 cart-loads are collected on the shores yearly. The precipitous southern coast does not present a favourable site for the growth or collection of these plants. In summer-time the fields are often covered with beds of sea-weed spread out to dry: it is afterwards used as a fuel in winter, and the ashes, carefully collected, are sold for manure, and are considered so essential to the soil, that it is a proverbial expression, "if there be no vraic, there will be no corn." The fused mass of ashes contains various salts, and appears particularly rich in iodine.—R. E.]

34 GOULD, THOMAS—Manufacturer.

Salts, similar to those commonly called "Epsom," produced from salt or chloride of sodium.

[Epsom salts consist chemically of a sulphate of magnesia. The preparation exhibited appears to be sulphate of soda in a crystalline form, since it is obtained by the decomposition of choride of sodium.—R. E.]

35 DOBREE, D., *Forest Rectory, Guernsey*.—Proprietor.

Original Guernsey frock, of Guernsey home knitting, in constant use among labourers and fishermen; worn over the shirt.

Frock of Guernsey wool and Guernsey home knitting, used instead of flannel.

Drawers, men's and women's stockings, nightcaps, gloves, fishermen and labourers' cravats, and slippers of Guernsey home knitting.

36 LE BEIR, N., *St. Peter's Port, Guernsey*.—Proprietor.

Guernsey farm saddle: local name of material "han," in constant use on every farm for riding, and for carrying bags and panniers. Mat and footstool of "han," in common use. Bullock's and horse's collar of "han." Coil of "han" rope, used by fishermen: this does not harden in the salt water. Shackles of "han," used for cattle; these do not cut the feet. "Han,"—a hank of the raw material, common in Guernsey; it grows in the meadows.

["Han," or, in botanical language, *Cyperus longus*, is employed by the peasantry of Guernsey for a variety of purposes, for which hemp is elsewhere used. The fibre has a certain degree of tenacity, and is twisted and formed into ropes, mats, &c. Cattle are constantly tethered by a rope of this material.—R. E.]

37 DOREY, D., *St. Mary de Castro, Guernsey*.—Proprietor.

Guernsey osier crab-pot; to be sunk in deep water, baited inside, to catch lobsters, conger, &c. Osier fish-basket. Large osier bait-pot, intended for a few days' consumption, left at sea to keep the bait alive. Small bait-pot, for one day's use, towed after the boat.

[The fishery around both Guernsey and Jersey is excellent, and the markets are well supplied. The conger eel is caught of a very large size, and is much employed in the domestic cookery of the islands. At Jersey an important oyster-fishery exists, from which large quantities of oysters are sent to Southampton and to other places.—R. E.]

38 Guernsey home-knitting work by cottagers.

39 GOODRIDGE, J., jun. (of the "Channel Islands Express" steamer)—Inventor.

Model of a life-boat.

40 VALPY, Mrs., *King Street, St. Helier, Jersey*.—Producer.

Specimens of conchology of Jersey, collected, classified prepared, and arranged by the exhibitor during a twenty-two years' residence in Jersey.

[One of the most interesting members of this conchological series is the *Aumer*, or *Oreille de mer*, a shell-fish which is collected abundantly at certain seasons. It is used in a variety of ways for food, and the shell is preserved, and exported to England; it is valued for its pearly iridescence, and is largely used at Birmingham by the makers of inlaid papier maché.—R. E.]

Leather frame. Large knitted quilt.

41 BERTRAMS, Mrs., *St. Helier, Jersey*.—Manufacturer.

Pair of socks, knit without glasses by the exhibitor, aged ninety-three.

42 MARQUARD, P., Blacksmith, *North Pier*.—Inventor and Producer.

Model of a patent truss for the yards of ships, of Muntz metal.

43 POPE, Mrs., *Halket Place, St. Helier, Jersey*.—Manufacturer.

Various descriptions of confectionery in sugar, manufactured by exhibitor.

44 ELLIS, Miss—Proprietor.

Specimens of fine workmanship in leather, shown in a pier-glass frame and stand, with brackets.

45 DRAKE, FRANCIS—Inventor.

Model of collapsing life-boat.

46 RANDELL, Miss, *Guernsey*.—Producer.

Two mats worked in wool.

47 LETAUREL, J. H.—Producer.

Acts of the Martyrs, in French.

48 MANUEL, H. L., *Jersey*.—Producer.

Two pairs of Newfoundland fishing boots.

49 STAFFORD, Mrs. B. A., *Guernsey*.—Producer.

Stand of wax fruit.

MEDITERRANEAN.

MALTA.

NORTH AREAS, I. J. 32.

(Commissioner, C. J. GINGELL, Esq., of Valetta, and 66 Cornhill, London.)

FROM Malta has been forwarded, by about thirty-four exhibitors, a collection of interesting objects representative of its local manufactures. The only specimens of raw material sent are some pieces of Maltese stone, oiled for pavement, and in their natural state, and some specimens of cotton and silk of native production. In addition to these are a few samples of seeds and wheat. The nankeen cotton cloth of Malta has been



sent by several exhibitors. Some elaborate specimens of embroidery are also among these articles. A very attractive collection is that of the jewellery and other articles in gold and silver filigree. The chaste and delicate appearance of these objects is extremely pleasing. A prominent part in the collection is formed by the stone vases, some of which exhibit skilful execution and tasteful design. The figures in wax will likewise attract notice. These articles are placed next to those of India, on the North side of the Western Nave.

- 1 TONNA, JOSEPH, *Strada Forni, Valletta*—  
Manufacturer.  
Double-bass fiddle, made of bird's-eye maple.
- 2 BONAVIA, CNORATO, *Casal Navaro*—Producer.  
Specimens of cotton sail-cloths of four, five, six, and seven threads of different lengths.  
Specimens of chequered cotton cloth for carpeting.
- 3 SCHEMBRI, G., *Valletta*—Manufacturer.  
Cotton tissues :—  
Pieces of natural Malta nankeen, white, narrow, and wide squares. Piece of light colour, and damasked square.
- 4 PULIS, G. MONTEBELLO.  
Cotton fabrics :— Piece of natural nankeen, plain. Piece of nankeen, striped with Malta raw silk. Piece of superfine plain nankeen.  
Sample of common Maltese cotton. Common Maltese nankeen cotton. Indian nankeen cotton. Sea-island cotton. Mastodon American cotton.  
Sample of cummin seed. Aniseed. Sesame seed.  
Sample of Maltese hard wheat (called *Tomnia*). Soft wheat.  
Samples of cotton thread, from four kinds of cotton. Cotton thread, from common Maltese cotton. Maltese cotton.  
Sample of Maltese silk and cocoons.  
[After prolonged and patient labour the soil of Malta has been made to yield its fruits to the husbandman, and abundant crops are obtained. Among these cotton forms the most important. About four million pounds of this fibre are exported yearly.—R. E.]
- 5 VILLA, FRATELLI, *Strada Mercanti, Valletta*—  
Manufacturer.  
Cotton fabrics :—  
White and red cotton blankets ; figured counterpanes. An assortment of straw hats.
- 6 FENECH, VINCENZO, *Floriana*—Producer.  
Specimen of Maltese bookbinding, two volumes.  
Collection of ancient and modern costumes of Malta.
- 7 GRAVAGNA, MARIA, *Valletta*—Producer.  
Several pieces of broad lace.
- 8 NAUDI, Signora ROSINA, *Valletta*—Producer.  
Velvet bags embroidered ; plain embroidered muslin dress ; plain embroidered baby's dress.  
Toilet cover (lace, Greek style) ; embroidered handkerchief ; various specimens of lace.  
Various pairs of mittens.
- 9 ENRIQUEZ, Signora MARIA, *Valletta*—Producer.  
Variety of black silk mittens.  
Habit shirts, plain embroidered.
- 10 SCHEMBRI, ANTONIA, *Valletta*—Producer.  
Specimens of lace with gold thread.  
Collars. Two lace collars.
- 11 GOZO, SALVO DEL—Producer.  
Specimens of black silk lace.
- 12 CASHA, COSTANZA, *Valletta*—Producer.  
Piece of lace of Greek pattern.
- 13 POLITO, CANONICO, *Vittoriosa*—Producer.  
Specimen of lace (Greek pattern).
- 14 CAMILLERI, E., *Valletta*—Producer.  
Specimen of broad lace, with pieces for sleeves for clerical dress. Various specimens of lace.
- 15 VELLA, PAOLO, & Co., *Valletta*—Producer.  
Specimen of lace.
- 16 CAMILLERI, FORTUNATA, *Valletta*—Producer.  
Specimen of lace.
- 17 GRECH, GIUSEPPINA, *Valletta*—Producer.  
Baby's plain embroidered muslin dress.
- 18 LAGRESTIZ, Signora ELENA NUZZO, *Valletta*—  
Producer.  
Sample of embroidery with silks : top of a pincushion.
- 19 FENECH, ANTONIA—Producer.  
Paper envelopes, embroidered with silks and gold.
- 20 AZZOPARDI, JOSEPH MOORE—Producer.  
Pair of mittens, with beads.
- 21 DIMECH, Mrs.—Producer.  
Various specimens of long and short mittens. Long mittens with beads.  
Sample of lace. A breadth of black tulle, embroidered. Black lace. Flounce and breadth of broad lace. Numerous specimens of lace. Collar and two cuffs.  
Maltese nankeen dress, embroidered with wool. Maltese nankeen girl's dress, embroidered with silk. Two pieces of Maltese nankeen.
- 22 THE CONSERVATORIO OF SAN GIUSEPPE—Producer.  
Knitted collars ; knitted fronts of habit shirts.  
Specimens of knitted broad and narrow lace ; knitted caps ; knitted thread stockings.
- 23 PORTELLI, ANTONIO, *Strada Strella, Valletta*—  
Producer.  
Silver filigree reticule.
- 24 CRITEIN, E., *Strada Forni, Valletta*—  
Manufacturer.  
Specimens of gold filigree work :—Bracelets ; rose-chain bracelets. Knot brooches. Double pin for hair. Rose-chains. Flat and rose rings, &c.  
Articles in silver filigree :—Basin. Oval plates, with flowers. Round plates. Card cases. Candlesticks. Teaspoons. Cups. Wreath for the head. Bead bracelets. Large double pin. Small double pins. An arrow for the hair. Bouquet-holder brooches. Stars to suspend. Knot, tie, and shawl brooches. Rose-chain, &c.



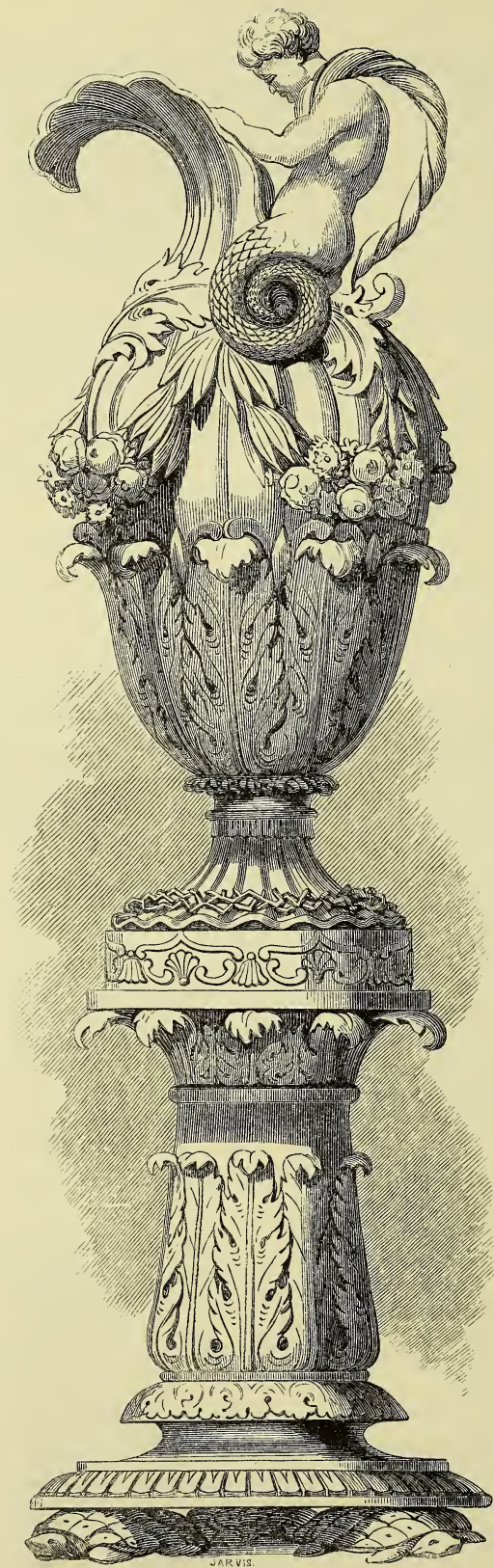

Gold articles :—Gold rose-chain for waistcoat. Broad flat rings.

[The peculiar art of the filigree-worker, originating in Italy, is carried on with success at Valletta, one of the principal towns in Malta. The delicacy of this description of work and the beauty of the articles produced have long rendered it valuable among the admirers of jewellery.]

25 FALSON, S., *Strada Reale, Valletta*—  
Manufacturer.

Articles in gold :—Maltese rose-chain. Bracelets: with scales; cameo; coral; oriental cameo, &c. Brooches: with bunch of flowers; in the form of a knot; and with a rose and flowers. Chain: imitation of Venice work. Large-sized pins. Bracelet, lace pattern. Pair of hair-pins. Various pins: with coral; mosaic work; cameo, &c. Shirt-studs. Chain rings. Rose-chain rings. Small rose-chain necklace, &c.

Ornaments in silver :—Filigree flower-stands. Flower ornaments for the hair. Hair-pins. Plates, and small cups. Bead bracelets; rose bracelets; and bracelets of Gothic pattern; rose-chain bracelets. Breast-pins, and chatelaines. Arrows for the hair. Large and small flowers. Shawl-pins and pineushions. Pins for necklaces, &c. Money-bag, and eard cases. Bead buttons, various sizes. Butterfly of gold and silver. Pins in the form of a cornucopia. Small pins.

26 DARMANIN, JOSEPH, & SONS, *Strada Levante, Valletta*—Manufacturer.

Inlaid marble table-top, with the Royal arms, 4 feet long, 3 feet broad.

Inlaid marble table-top, with fancy scroll, &c., in the centre, 3 feet square.

Inlaid marble table-top, with Etruscan vase in the centre, 2 feet 6 inches in diameter.

Inlaid marble table-top, with the emblem of Carthage in the centre, 2 feet 2 inches in diameter.

Pieces of Malta stone, oiled and prepared for pavement. Drip-stone of Malta stone. Specimens of Malta and Gozo stone, and stalactite.

Vase, with pedestal of red Gozo marble. Wax and cloth figures.

[Malta and Gozo consist of stratified deposits, chiefly or entirely of the middle part of the tertiary period. They include, in descending order—1. A coral limestone, containing cretaceous nodules, some of which are variegated with yellow and white, and used for ornamental work, under the name of Gozo marble. 2. A sandstone and blue clay, from 100 to 150 feet thick, containing iron, gypsum, and sulphur. 3. Five beds of freestone, about 100 feet thick in all, and chiefly calcareous, though with much sandy admixture: these are much used for building purposes, not only in Malta and Gozo, but in all parts of the Mediterranean, the lowest bed being the most available, on account of the facility with which it is worked. 4. A yellowish-white semi-crystalline limestone, of very considerable but unascertained thickness, exposed to the extent of 400 feet on the coast of Gozo, and much used for building purposes where hardness is required. Some of the valleys of Malta and Gozo are picturesque and fertile where the blue clay (2) allows the water to be retained, and thus originates springs.—D. T. A.]

27 DECESARE, P. PAOLO, *Strada San Giovanni, Valletta*—Carver.

Large vases, 5 feet 2 inches in height, and 2 feet 10 inches in breadth. One of these vases is represented in the adjoining column. (Fig. 1.)

Small jugs, 1 foot 6 inches in height, and 1 foot 2 inches

Fig. 1.

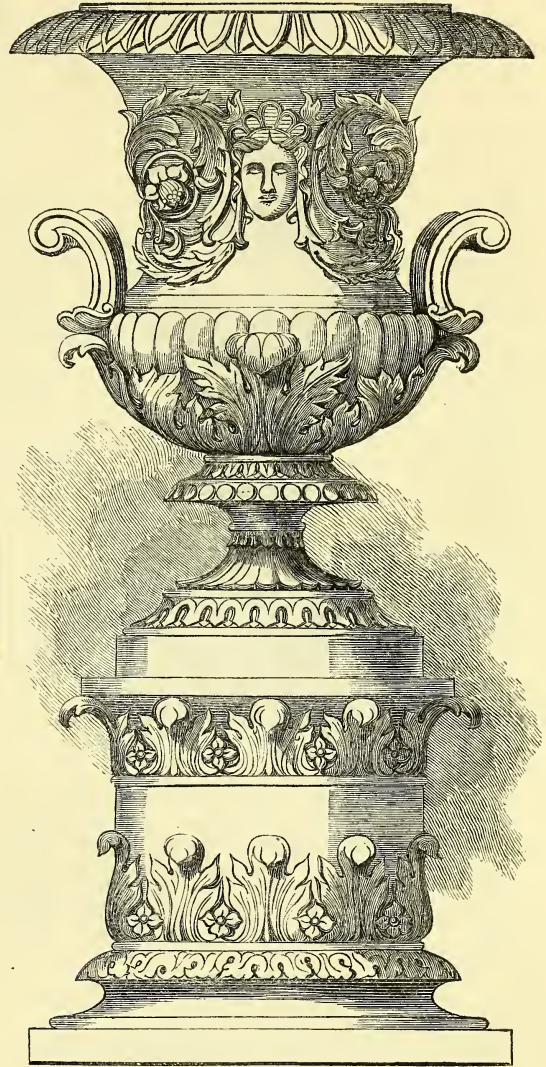

Decesare's Stone Vase.

in breadth. One of these jugs is shown in the engraving, Fig. 2, p. 946.

Very large jugs, with pedestals, 7 feet in height, and 1 foot 11 inches in diameter. The accompanying Plate, 56, represents one of these jugs. Another is represented in the engraving in the next page. (Fig. 3.)

28 DIMECH, FERDINAND, *Strada Teatro, Valletta*—Carver.

Specimens of stone earvings :—  
Candelabrum, 6 feet in height, and 2 feet 8 inches in breadth.

Large vase, 4 feet in height, and 3 feet 9 inches in breadth.

29 SOLER, JAMES (Foreman to Mr. G. MUIR),  
*Strada Reale, Valletta*—Carver.

Specimens of stone carvings :—  
Vase with handles: size 1 foot 8 inches high, and 2 feet 10 inches broad.

Jug with vine-leaves ornament: size 2 feet 3 inches in height, 1 foot 2 inches wide. Oval vase, 1 foot 4 inches in width. Small basket.

Fig. 2.



Decesare's Jug of Maltese Stone.

30 TESTA, SALVATORE, *Strada San Giovanni, Valletta*—Carver.

Vase, ornamented with satyrs and flowers: size 4 feet 8 inches in height, and 2 feet 9 inches in breadth. This vase is represented in the illustration in p. 947. (Fig. 1.)

Vase, ornamented with eagles: size 1 foot 9 inches high, and 1 foot 3 inches broad. This vase is shown in the engraving in p. 947. (Fig. 2.)

31 BUTTIGIEG, MICHELE, *Birchircara*—Producer.

Specimens of manufactures in straw:—

Straw mats, hats, and caps. Samples of straw plaits.

Waterproof hats: two pliable oil-skin hats; two strong oil-skin hats.

32 GERADA, ANTONIO, & DAUGHTERS, *Strada Mercanti, Valletta*—Producer.

Basket of artificial flowers, with shells.

33 TESTA, FORTUNATO, *Strada Santa Lucia, Valletta*—Carver.

Vase of antique form, ornamented with satyrs, a wreath of flowers, and vine-leaves: size 5 feet 4 inches in height, and 2 feet 4 inches in breadth.

Vase of antique form, ornamented with vine-leaves: size 4 feet in height, and 1 foot 9 inches in breadth.

Common vase, 1 foot 6 inches in height, and 1 foot 4 inches in breadth.

34 THE CANONICO POLITO, *Vittoriosa*—Manufacturers.

Figures in wax, representing—

The grand master Valletta.

The grand master Lonzadari.

A knight of the order of Malta.

The grand master in warlike costume.

The Saviour.

Fig. 3.



Decesare's Stone Vase

Fig. 1.

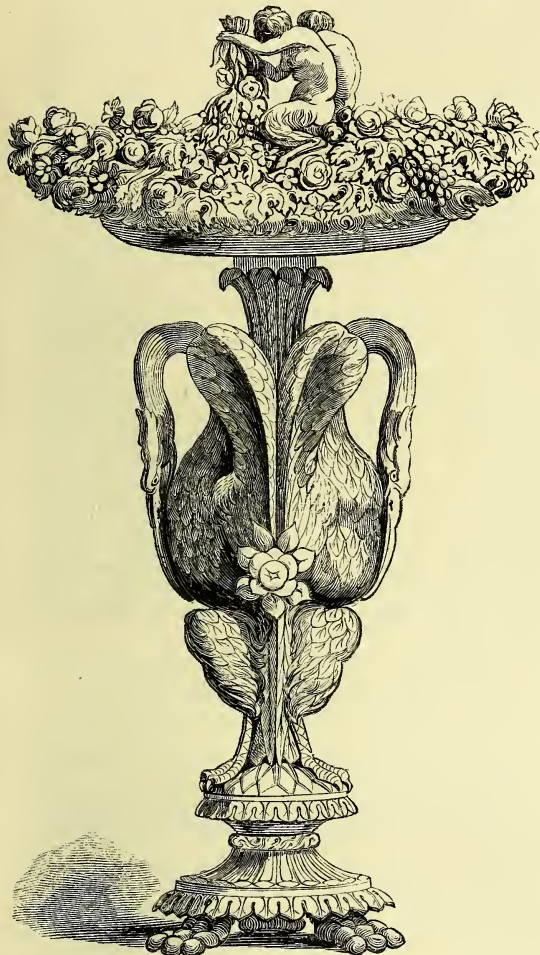

Fig. 2.



Testa's Stone Vases.

## GIBALTAR.

- 1 CHARRUY, PIERRE, *Gibraltar before the Exchange*—  
Producer.  
Razor strops, with handles of rock stones.

## IONIAN ISLANDS.

NORTH AREA, I. J. 30.

OWING to some misapprehension, the Ionians were without knowledge of the objects and purports of the Exhibition of 1851, until very recently. Unwilling, however, that the name of the Ionian Islands should alone be wanting in the list of nations on this great occasion, the Executive Committee appealed to an Ionian gentleman, who has been induced to collect together, by the kind contribution of certain noble and eminent individuals, who have served Her Majesty in those islands, such articles in their possession as might serve as specimens, to a very trifling extent, of the products, skill, and industry of the Ionians. These products are principally articles belonging to the classes of textile and ornamental manufactures. The specimens of embroidery exhibited are extremely rich and beautiful, and form a characteristic contribution to this collection. The filigree work is also exceedingly delicate, and illustrates a department of skill in the working of precious metals which has no representative in our own country. The brooches and medallions exhibit some of the favourite devices of the Ionian artists.—R. E.]

- 1 WOODFORD, Lady, 21 *Somerset Street, Portman Square, London*—Producer.

A Greek dress, made in Corfu.

A pair of silver bracelets, made in Corfu; the one with the motto "ΣΦΙΓΓΩ ΑΔΟΛΟΝ ΦΙΛΙΑΝ." "My pressure is that of friendship without guile;" the other, "Ο ΦΕΡΩΝ ΑΓΑΠΗΝ." "He who feels affection" (offers it to you).

A silver brooch of elegant pierced work, formed by a garland of grapes and vine-leaves, surrounding the emblem of the Seven Islands.

A brooch in silver filigree-work, with the head of Corcyra on the one side, for Corfu; the winged horse of Belerophon on the reverse, for Zante.

A Greek cap, made at Lefchimo, a village of Corfu.

Memorial clasp in gold, made at Corfu, and of remarkable workmanship; the gold filigree being placed on a plate of polished gold, which reflects it as from a mirror.

- 2 ΜΑΥΡΟΙΑΝΝΙ, Madame—Producer.

A gold bracelet, made at Corfu, of filigree-work, surrounding the emblem of the islands.

Two silk handkerchiefs, of fine fabric, of Zante manufacture.

An apron of muslin, made in Corfu, with a border worked on linen with the needle; somewhat similar to Dresden-work, but of larger stitch, on a very elegant and classical pattern, of grapes, vine-leaves, and butterflies.

An apron of crochet-work, remarkable for the beauty of the pattern and execution, and showing that what has but recently appeared in England as an accomplishment, has been for ages the common needlework of the Ionian peasant-girls. The border is of deep Dresden-work of magnificent effect, with emblematical designs of lions, Cupids, flowers, &c.

[These aprons are the ordinary work and every-day wear of the peasant-girls of Corfu. The dress of the Greek peasant-women, in general, being of an extraordinary richness, so that a peasant-bride's dress is often her dowry, being not unfrequently worth 400 or 500 dollars.]

## 3 MAVROIANNI, —, Producer.

Samples of Cephalonian currants.

The island of Cephalonia, though not so rich in currants as Zante, nevertheless supplies a great part of the quantity consumed in Great Britain.

Olive-oil, the growth of Corfu.

## 4 FITZROY, Lord CHARLES, 3 Grosvenor Square, London—Producer.

Three Zante silk scarfs.

A Zante handkerchief.

## 5 SEATON, LORD, for the INHABITANTS OF THE IONIAN ISLANDS—Producer.

Specimen of Cephalonian stone.

Silver seal, on which is engraved a ship without a rudder, the arms of Corfu.

Silver bracelets of various forms, some of them combining the seven medallions of the seven islands; a favourite device of Ionian jewellery. Others, uniting in fanciful form, devices of frosted and polished silver.

Silver brooches.

Specimens of olive-wood: one of them an olive-wood cup, cut out by a Greek peasant with a penknife.

Specimens of samplers, worked by Greek girls, each containing a Scriptural sentence, contained within a border of flowers of exquisite colour and arrangement.

A book-weight, made of a peculiar stone found in Cephalonia.

Zante scarfs, made of silk grown and dyed in the island; the patterns of the old Venetian taste.

Large and small pieces of raw silk of a very superior quality, as collected and spun by young ladies in the islands.

Velvet bag, richly embroidered in gold, from Santa Maura [the ancient Leucadia].

Cambrie handkerchief, of Cephalonian manufacture, embroidered with gold, from Santa Maura.

Bags and pocket-books embroidered in gold.

Gold bracelet, made after the pattern of an antique one found in a tomb.

Silver-gilt bracelet, of the same fashion.

Large brooch of silver, of fine workmanship and design, combining in the centre the lion and crown of England, as a large medallion, with seven medallions of the seven islands depending from it. The centre medallion represents the arms and emblem of the island of Corfu—"The flower of the Sea"—a female figure, supposed to be Coreyra, the daughter of Asopus, who was carried off by Neptune to the islands, seated upon a rock, holding in the hand of her extended right-arm an olive-branch. On the one side of her is a cornucopia, denoting the fertility of the island; and the other, an ancient galley, emblematic of the commercial spirit and wealth of its inhabitants. This ship, which is rudderless, sometimes stands alone as the arms of the island, and has been also supposed to take its origin in the ship of Ulysses, which was fabled to have been transformed into a rock, somewhat of the figure of an ancient vessel, which now stands at the entrance of the harbour. The letters *Κεγ* are the abbreviation of *Κεργκουα*, the ancient Coreyra.

The medallion, on the right, is marked by a tripod for Zante, and the letters *Ζαν*, the abbreviation of *Ζανυβος*.

The next to this, on the right, is the medallion of Santa Maura. The harp upon it symbolizes its fame, as the death-place of Sappho; the letters *λευ* being the abbreviation of its ancient name *λευκαδια*, Leucadia. Another emblem of this island is Bellerophon, on a winged horse, attacking the Chimæra, which it derives from its Corinthian colonisation.

The last on this side is Ithaca, marked with the head of its king Ulysses; the letters *Ιθα* being the abbreviation of *Ιθακη*, Ithaca.

On the right of the Corfu medallion is that of Cephalonia, the next island in magnitude, represented by Cephalus, the son of Mercury and Creusa, who, when condemned by the court of Areopagus to perpetual exile for having unwittingly killed his wife Procris, came to dwell upon this island. He is represented as reposing after the chase, a dart in his hand, and his dog at his feet. The letters *Κεφ* are the abbreviation of *Κεφαλλήνια*, Cephalonia, the ancient designation of the island.

Cerigo comes next. The letters *Κυθ* denote *Κυθαία*, the ancient Cythera, represented on the medallion by Venus, to whom the island was sacred, and who was fabled here to have had her birthplace and her domicile. The goddess is standing on her shell, drying her hair with the one hand, and holding in the other the famous apple.

Paxo, the smallest of the islands, comes last. Its sacredness to Neptune is denoted by his trident. The letters *Πα* are the abbreviation of *Παξο*, Paxo. This island is also represented by the helm, or rudder, of a ship within an olive garland.

Silver egg-cup, in silver filigree work.

Silver brooch, comprising seven medallions, with the arms of the seven islands engraved thereon.

Silver thimble, encircled with seven small medallions, with the arms of the islands.

Bags for ladies, of velvet, embroidered in gold, with raised work in coloured silk.

Round case, or lady's housewife, of velvet, embroidered.

Card-cases, or pocket-books, for ladies, of velvet, embroidered.

Shirt, of Ionian manufacture of raw-silk, such as is worn by the peasantry in summer.

Shirt, of Ionian manufacture of raw silk, such as a few years since was worn by the gentry of the islands in summer.

Gold ring, made at Corfu, with the initials of the party wearing it, and the emblems of the seven islands, usual as a present from friend to friend.

Gold ring, made at Corfu, such as is usually interchanged between brothers, there being as many hoops as there are brothers in the family; and the ring, by a peculiar shifting of the catch, forming either one whole ring, or a chain of so many links.

## 6 WARD, Sir HENRY—Producer.

A silver inkstand, by Anastasio Florias, of Corfu, silversmith.

A wooden lamp of olive-tree wood, common in the island of Corfu, and used in the Greek churches.

A knife, by Antonio Arlionoli, peasant, from Prinilla, in the district of Giri, Corfu.





### III.

## BRITISH POSSESSIONS IN AFRICA.

---

### SOUTH AFRICA.—WESTERN AFRICA. AFRICAN ISLANDS.

---

THE distinguishing feature of all the contributions to the Exhibition sent from the dependencies of Great Britain is the predominance of raw material and produce over manufactures and fine arts. There is much that is suggestive in this fact. The early development of the prosperity of a new country or colony is always necessarily more directly dependent on its natural products, and their application, than on the industrial arts. There is much to interest both the naturalist and the merchant in the objects exhibited.—R. E.

#### SOUTH AFRICA.

SOUTH AREAS, L. M. 30.

*Agent, Mr. H. WATSON, St. Peter's Chambers, Cornhill.*

THE collection from the Cape of Good Hope, added to that forwarded by the Agricultural Society, consisting of a variety of articles from South Africa, is the contribution of about sixty exhibitors. With the exception of a few specimens of furniture, and native manufacture in wood, &c., this collection is valuable chiefly as illustrative of the raw materials furnished by the districts which it represents. The minerals sent from the Maitland mines, inclusive of lead and iron ores, and also of graphite and coral, are the chief representatives of the first class of the Exhibition, with the exception of a slab of coloured marble from Natal, mounted as a table on a stand of oak. Specimens of crude and of partially-purified cream of tartar, under the name Argol, are sent, in Class 2, together with some medicinal plants and drugs. Several kinds of bark for the use of the tanner, walnut-oil, and oil from the sheep's tail and sea-elephant; some impure carbonate of soda, prepared from incinerated plants, called gunna ashes; specimens of orchilla weed, guano, and honey are also interesting. Among the vegetable products the berry wax, obtained probably from a species of *Myrica*, deserves notice. The articles of food represented consist of maize, wheat, flour produced in the Cape Colony, preserved fruits and provisions, and dried fruits. The skins of the wild animals, exhibited in their unmanufactured state, and also in the form of the karosses worn by the Kafirs, the ivory and elephants' teeth, and a large pair of ox-horns, measuring from tip to tip upwards of 8 feet, sent from Port Natal, will be considered interesting. Specimens of the feathers of the ostrich are also sent in illustration of this important article of colonial export. A tippet made from the feathers of various Cape birds is also exhibited.—R. E.

- 1 MAITLAND MINES, *Port Elizabeth*.  
Lead ore, from Port Elizabeth. Iron ore, from Uiten

hage. Graphite, from Cape Town. Coral, from Caledon. Oyster shells, from Uitenhage.

- 2 DE VILLIERS, P. I., *Paarl, Cape Town*.  
Argol, white and red.

[Argol is the name given commercially to the crude tartar (bitartrate of potash) which exists in the juice of the grape, and is deposited from wine in the fermenting casks, as alcohol becomes formed. The two colours are from the white and red wines respectively. The purified tartar obtained from this substance is used, either directly or indirectly, in dyeing, calico-printing, medicine, &c.—E. F.]

- 3 THALWITZER, M., *Cape Town*.  
Medicinal plants and drugs; "klipsweet."  
Bark for tanning, tamboukie wood, &c.

4 JEPPE, H., *Swellendam*.  
Medicinal plants and drugs. Specimens of soda. Mustard seeds. Walnut oil.

- 5 BAYLEY, J. B., *Caledon*.  
Samples of preserved fruits; gold of pleasure.

- 6 VOLSTEEDT, J. P., *Caledon*.  
Samples of maize.

- 7 PAARDEBERG, J. S. C., *Malmesbury*.  
Samples of honey.

- 8 TRUTOR, H. A. O., *Cape Town and Caledon*.  
Samples of flour. Eggs of the ostrich.

[The ostrich belongs to the natural family of *Struthionidae*. Its eggs are considered great dainties by the Hottentots, and are cooked by being plunged into the live embers of a wood fire. In the shallow pits of sand where the eggs are deposited, a large number are occasionally found. The eggshells are extremely dense and hard, and are converted into various articles of use and ornament.—R. E.]



- 10 BOTANIC GARDEN, *Cape Town*.  
Samples of cotton.
- 11 MANUEL, C., *Cape Town*.  
Samples of Natal cotton.
- 13 CLARENCE, RICHARD, *Cape Town*.  
Sea-elephant oil; sheep's-tail oil.  
[Sea-elephant. This animal is the largest of the seal-tribe, and is distinguished by a tumid pendulous proboscis which, in the male, can be distended and erected, whence the name applied to the species by the sealers. The sea-elephant (*Phoca proboscidea*, or *Cystophora proboscidea*) is a native of islands in the Southern and Antarctic oceans. It attains a length of thirty feet.—R. O.]
- 14 KUNHARDT & Co., *Cape Town*.  
Sheep's-tail oil.  
[The variety of the domestic sheep at the Cape of Good Hope is characterised by a tendency to an enormous accumulation of fat in the tail, which would in some cases drag upon the ground, and become ulcerated, were it not for the precaution of fastening to it a board on wheels, by which it is dragged along.—R. O.]
- 15 THOMSON, GEORGE, *Cape Town*.  
Sea-cow teeth.
- 16 MEESER, F., *Cape Town*.  
Ox horns, polished, and rough.
- 17 WATERMEYER, C., *Green Point*.  
Samples of hemp (aloe).
- 18 BLACKBURN, J., *Cape Town*.  
Karosses. Specimens of wild cats' and jackals' paws.
- 19 DEANE & JOHNSON, *Cape Town*.  
Specimens of karosses.  
[Karosses are cloaks, such as are worn by the Kafirs, made of the skins of wild animals. The numbers of rare and beautiful quadrupeds inhabiting South Africa, render these skins objects of much interest to the naturalist, as well as articles of intrinsic value.—E. F.]  
Ivory; elephants' tusks. Three Malay hats.
- 20 HANBURY, E., *Cape Town*.  
Skins of wild animals.
- 21 BRIDGES, C., *Cape Town*.  
Skins of wild animals. Kafir chair, battle-axe, hoe, &c. Buffalo and other horns. Rhinoceros-hide sticks and whips. Stone box, &c.
- 22 CLUAPPINI, A. & Co., *Cape Town*.  
Skins of wild animals. Twelve goat skins, weighing 65 lbs. each.
- 23 RUTHERFOORD, H. E., *Cape Town*.  
Samples of wheat. Ostrich feathers.  
[The export of ostrich feathers from the Cape is of great importance to the colony, and the prosperity of this trade necessarily affects the tribes of native hunters. Consequently, those circumstances which interfere with the demand for feathers at home, affect ultimately the Kafir hunters themselves. The recent disturbances produced a great impression upon the trade in ostrich feathers, and the results are severely felt by the native hunters of these birds.—R. E.]
- 26 WOODMAN, J. C., *Cape Town*.  
Manufactured olive wood.  
[The olive wood of the Cape is the product of true olive-

trees, species of *Olea*, but all distinct from the *Olea* of Europe.—E. F.]

A cabinet, composed of seven species of wood, especially of stinkwood, so called on account of the offensive smell of the wood when newly cut.

[The peculiar wood here alluded to is that of a tree belonging to the order *Lawraceæ*. Its botanical name is *Oreodaphne fetens*. Its odour is universally described as most intolerable. The same tree exists in the Canary Islands, where it is known under the name of Til.—R. E.]

- 27 THALWITZER, M., *Cape Town*.  
Curiosities; bows and arrows; Bushman's blanket. Bark for tanning.

- 28 HANBURY, E. J., *Cape Town*.  
Rhinoceros-horn sticks and whips.  
[There are several species of rhinoceros in Africa; one of them ranges throughout the central regions; two are peculiar to the south. Three African species have two horns, the other has only one horn. They are all quite distinct from the Asiatic species. The horn is formed out of an accumulation of metamorphosed hairs.—E. F.]

Leopard-skin.

- 29 MOAG, W., *Cape Town*.  
Kafir warrior's head-dress.
- 30 FOORD, R., *Cape Town*.  
Model in clay.
- 30A SUTHERLAND, J., 17 *Great St. Helen's, London*,  
(Agent to Twist Niet Steam Mills, of Messrs.  
J. F. FREDERICKSEN and T. SUTHERLAND, jun.)  
Wheat flour, the produce of the Cape Colony.

- 30B BAZLEY, T., *Natal*.  
Three bales of cotton, from Port Natal.

SOUTH AFRICAN PRODUCTIONS, forwarded by the AGRICULTURAL SOCIETY OF THE CAPE OF GOOD HOPE.

- 31 REITZ, RIEDA, & Co.—Samples of fine wool.
- 32 BREDÁ, D. J. VAN, *Hatch River*.—Samples of fine wool.
- 34 PRINCE, COLLISON, & Co.—A barrel of fine flour.
- 35 VOLSTEDT, J. P.—Preserved fruits, viz., bitter oranges, green apricots, green figs, naartjes, citron, candied figs, candied naartjes, and oranges.
- 36 MOSS, N.—Cigars and kanaster tobacco.
- 37 SEARIGHT, J.—Two tins Malagas guano.
- 38 SMITHERS, J.—Tallow and soap.
- 39 SCHLUSSLER, H.—Cask of salt beef.
- 40 MARTIN, W.—Cask of salt pork.
- 41 MOSSO, T.—A roll of sole leather.
- 42 SCHMIETTERLOW, C.—A tippet made from the feathers of various Cape birds. Samples of sole leather Sea-elephant oil.
- 43 MISSIONARY STATION, GROENKLOOF.—Quince walking-sticks, stained; riding whip, stained; and olive wood work-box.
- 44 MORAVIAN MISSIONARY STATION at GENADENDAL.—Double chopping knife, bread-cutting and hunting knives, vine cutter, pocket knives, and boschlemmer knife. Box composed of 30 specimens of various woods, in the rough and polished state; olive wood box.
- 45 LINDENBERG, J., *Worcester District*.—Specimen of berry wax; specimens of beeswax.

[The tree which yields the "berry wax" is, in all probability, *Myrica cerifera*, the berries of which yield it abundantly. Possibly it may be obtained from other species of *Myrica*. The trees from which it is obtained are found abundantly at the Cape of Good Hope.—R. E.]

46 BARN, T. A.—Sack of wheat.

47 DUMBLETON, H., *George District*.—Box, containing forty-three specimens of Cape woods, in the bark, rough and polished. Specimens of Colonial wool in the rough state.

[The wool of the native breed of Cape sheep is of little value, and forms but an unimportant article of commercial enterprise. That of the sheep of the Merino breed is, however, highly esteemed, and is annually exported to the value of about 25,000*l.*—R. E.]

SAMPLES of various WOODS indigenous to SOUTH AFRICA.

| No. | Vernacular Names.           | Uses.                                                        | Quality.                    | Locality.                                     | Height of Stem. | Diameter.  | Botanical Names.                  |
|-----|-----------------------------|--------------------------------------------------------------|-----------------------------|-----------------------------------------------|-----------------|------------|-----------------------------------|
| 1   | Tambookie wood . . .        | Sawdust used as an emetic by the Zoolas.                     | Very hard and tough.        | Port Natal . . . . .                          | Feet.<br>..     | ..         | . . .                             |
| 2   | Pear (white) . . .          | In waggon-work, for felloes, &c.                             | Hard and tough              | Olifantshoek, Zizikamma .                     | 15 to 20        | 2 to 3 ft. | Imbricaria obovata.               |
| 3   | Iron wood (white) . . .     | For axles, poles, &c., of waggons.                           | Very hard and tough.        | Krakkakamma, Zizikamma, &c.                   | 20 ,, 30        | 2 ,, 3 ,,  | Asaphes (Boscia) undulata.        |
| 4   | Wild granate . . .          | For cabinet-makers' tools .                                  | Fine-grained and tough.     | Eastern forests . . . . .                     | 5 ,, 10         | 2 ,, 5 in. | Burchellia capensis.              |
| 5   | Beech wood . . . . .        | For waggon pole-tangs and felloes.                           | Soft and tough              | Forests throughout the Cape Colony.           | 15 ,, 20        | 2 ,, 4 ft. | Manglilla (Mrysiue) melanophlees. |
| 6   | Wild sage . . . . .         | By cabinet-makers for chairs, &c.                            | Hard and heavy              | Ravines throughout the Cape Colony.           | 6 ,, 10         | 3 ,, 5 in. | Tarchonanthus camphoratus.        |
| 7   | Alder (red) . . . . .       | Waggon felloes and planks                                    | Hard and tough              | Ravines along the water-courses.              | 15 ,, 20        | 2 ,, 3 ft. | Cunonia capensis.                 |
| 8   | Candlewood or cherry        | Waggon-building and other purposes.                          | Very hard and heavy.        | Edging the watercourses in ravines.           | 10 ,, 15        | 1 ,, ,,    | Celastrus rostratus.              |
| 9   | Assagai wood . . . . .      | Preferred especially for waggon-building.                    | Hard and very tough.        | Moist and stony places . .                    | 20 ,, 30        | 2 ,, 3 ,,  | Curtisia faginea.                 |
| 10  | Black olive . . . . .       | Furniture and waggon-work                                    | Very hard and tough.        | Rocky places . . . . .                        | 6 ,, 10         | 1½ ft.     | Olea verrucosa.                   |
| 11  | Wild elder . . . . .        | Table-feet and chairs . . .                                  | Hard and tough              | Woods edging rivers . . .                     | 8 ,, 0          | 7 in.      | Chilianthus arbo-reus.            |
| 12  | White olive . . . . .       | Waggon-work, poles, &c. . .                                  | Hard and tough              | . . . . .                                     | 15 ,, 20        | 2 to 3 ft. | . . .                             |
| 13  | Cedar . . . . .             | Coopers' work, water-wheels, not being affected by water     | Light, short, and resinous. | High rocky places in the Cedar Mountains.     | 10 ,, 25        | 1 ,, 4 ,,  | Callitris Ecklonii.               |
| 14  | Onderbosch . . . . .        | Waggon-tents, thatching-spars.                               | Very tough and durable.     | Underneath high trees in the forests.         | 5 ,, 10         | 1 ,, 3 in. | Trichocladus crinitus.            |
| 15  | Safranwood . . . . .        | Waggon-work, the bark for tanning.                           | Hard and close              | Woods in the eastern part of the colony.      | 10 ,, 15        | 1 ,, 2 ft. | Crocoxyton excelsum.              |
| 16  | . . . . .                   | Waggon-work . . . . .                                        | Hard . . . . .              | . . . . .                                     | ..              | ..         | Mystroxyton.                      |
| 17  | . . . . .                   | Furniture-legs, &c., and tools                               | Hard and tough              | Shady spots in ravines . .                    | 5 ,, 12         | 6 to 8 in. | Royena lucida.                    |
| 18  | Silkbark . . . . .          | Carriage-poles, spars. The bark, when broken, appears silky. | Tough and close             | Woods in ravines . . . . .                    | 7 ,, 12         | 7 ,, 9 ,,  | Celastrus.                        |
| 19  | . . . . .                   | Waggon-work, and the bark for tanning.                       | Very tough . . . . .        | Forests . . . . .                             | 5 ,, 10         | 1 ,, 8 ,,  | Rhus tomentosa.                   |
| 20  | Red wood . . . . .          | Furniture, tools, &c. . . . .                                | Short and hard              | Forests in the eastern districts.             | 12 ,, 15        | 1 ,, 2 ft. | Diporidium arbo-reum.             |
| 21  | Gomasie wood . . . . .      | Veneering and tools . . . . .                                | Hard and close              | Forests of Nysna River and eastern districts. | 12 ,, 15        | 1 ,, 9 in. | Gonioma Kamassi.                  |
| 22  | . . . . .                   | Waggon-work and tools . . . . .                              | Hard and tough              | Ravines, shady and moist places.              | 7 ,, 12         | 3 ,, 10 ,, | Celastrus?                        |
| 23  | Pear (hard) . . . . .       | Waggon-poles, axles, &c. . .                                 | Hard and tough              | Stony and moist places within the colony.     | 15 ,, 20        | 2 ,, 3 ft. | Olinia cymosa.                    |
| 24  | Ningroe . . . . .           | . . . . .                                                    | Hard and heavy              | . . . . .                                     | ..              | ..         | . . . . .                         |
| 25  | Yellow wood . . . . .       | Beams, planks, and building.                                 | Soft and light . . . . .    | Forests of George District.                   | 15 ,, 20        | 2 to 4 ,,  | Podocarpus elongatus.             |
| 26  | . . . . .                   | Spars, rafters, &c. . . . .                                  | Soft and light . . . . .    | Moist places by rivulets, Eastern Province.   | 10 ,, 15        | 1 ,, 7 in. | Virgilia capensis.                |
| 27  | Quarribush . . . . .        | Felloes, the berries as food .                               | Short and hard              | Woods of Eastern Province                     | 6 ,, 8          | 6 ,, 10 ,, | Euclea undulata.                  |
| 28  | Blackbark . . . . .         | Waggon-poles, tools, &c. . .                                 | Hard and very tough.        | Moist and shady places . .                    | 10 ,, 12        | 1 ft.      | Royena villosa.                   |
| 29  | Iron wood (black) . . . . . | Waggon-work . . . . .                                        | Very hard and tough.        | Forests of Eastern Province                   | 13 ,, 20        | 2 to 3 ft. | Olea undulata.                    |
| 30  | Alder klip . . . . .        | Waggon work . . . . .                                        | Hard and close              | . . . . .                                     | 10 ,, 15        | 1 ,, 2 ,,  | Plectronia.                       |
| 31  | Stinkwood . . . . .         | Furniture, gun-stocks, waggon-work                           | Hard and tough              | Many forests . . . . .                        | 20 ,, 30        | 3 ,, 5 ,,  | Oreodaphne bullata                |
| 32  | Ash . . . . .               | Furniture, planks . . . . .                                  | Soft and tough              | Forests of Eastern District                   | 10 ,, 20        | 1 ,, 3 ,,  | Ekebergia capensis.               |
| 33  | Milkwood . . . . .          | Felloes, boat-ribs, and waggon-work.                         | Hard, milky, and tough.     | Stony places . . . . .                        | 5 ,, 10         | 1 ,, 3 ,,  | Sideroxyton inerme                |
| 34  | Horsepis . . . . .          | Felloes . . . . .                                            | Hard and tough              | Forests of Eastern Province                   | 5 ,, 10         | 1 ,, ,,    | Hippobromus alatus.               |
| 35  | Guntsam . . . . .           | . . . . .                                                    | Tough . . . . .             | . . . . .                                     | ..              | ..         | . . . . .                         |
| 36  | Crossthorn . . . . .        | Waggon-spars, poles, &c. . .                                 | Hard and tough              | Woods in ravines . . . . .                    | 5 ,, 8          | 3 to 9 in. | Plectronia ventosa.               |
| 37  | Wild chestnut . . . . .     | Beams, planks, &c. . . . .                                   | Soft and light . . . . .    | Forests in ravines in Eastern Province.       | 15 ,, 30        | 3 ,, 4 ft. | Calodendron capense.              |
| 38  | Alder (white) . . . . .     | Furniture, planks, &c. . . . .                               | Tough and soft              | Moist places in ravines in Eastern Province.  | 10 ,, 12        | 2 ,, 3 ,,  | Weinmannia trifoliata.            |
| 39  | Noentigara . . . . .        | . . . . .                                                    | Hard and close              | . . . . .                                     | ..              | ..         | Euclea.                           |
| 40  | Black wood . . . . .        | Tools, furniture, &c. . . . .                                | Tough and hard              | . . . . .                                     | ..              | ..         | Royena.                           |
| 41  | Yellow wood . . . . .       | Deals, beams, planks, &c. . .                                | Light and short-grained.    | Forests in Eastern Province                   | 20 ,, 50        | 2 to 5 ft. | Podocarpus latifolius.            |
| 42  | Kooboo . . . . .            | Waggon-work, felloes, &c. . .                                | Light and short-grained.    | Woods in Eastern Province                     | 5 ,, 8          | 1 ,, 2 ,,  | Mystroxyton Kubu.                 |
| 43  | White wood . . . . .        | Rafters, spars, &c. . . . .                                  | Light and soft . . . . .    | . . . . .                                     | 10 ,, 12        | 1 ,, 8 in. | Virgilia.                         |

- 48 SCHEUBLE, J. H., & Co.—Specimens of medicinal herbs and drugs.
- 49 SEPPE, H.—Impure carbonate of soda, prepared from gunna ashes.
- 50 PASS, A. DE—Samples of guano.
- 51 WATERMEYER, C.—Orchilla weed.
- 52 JOUBERT, J. G.—Honey.
- 53 BUCHANAN & LAW—An elephant's tusk, weighing 103 lbs., another weighing 97 lbs.
- 54 CLARENCE, R.—Dried fruits, viz:—Almonds, peaches, raisins, apricots, pears, currants, and walnuts.  
Samples of sea-elephant oil.
- 55 CALF, J.—Specimens of plumbago, Fuller's-earth, &c. Box of oyster shells, of geological interest, from position of deposit being at the top of Grass Ridge.
- 56 GREIG, G., & Co.—Specimens of iron ore.
- 57 A library chair, presented to C. B. Adderley, Esq., M.P., by the inhabitants of the Eastern province of the colony of the Cape of Good Hope.

[The chair was designed by T. Baines, and carved by J. Hart, of Graham's town. The back consists of two panels, carved, in wood of a lighter shade than the framework; each panel being enclosed in scroll-work. Between the upper and lower division, and in the centre of the back of the chair, is a cluster of native weapons and implements; the assagai and the shield of the Kafir, the bow and quiver of the wandering Boshman, the war-axe and plume of the Bechuana. On one side are placed the arms of the British settler, his rifle, hunting-knife, and pouch; on the other side, the long elephant gun, the powder-horn and belt of the Dutch Boer. The upper panel represents a forest scene. The principal group in the immediate foreground consists of an elephant, rhinoceros, and buffalo; on the left, a gnu is represented galloping; in the distance, are groups of giraffes and ostriches; and above, the carrion vulture appears to soar. The lower panel represents a South African scene. A waggon is about to descend the bank of a rivulet. On a ridge, overlooking the drift, down which the leading oxen are descending, is a Kafir hut. In the mid-distance is placed a frontier homestead, with verandah and porch; and rising immediately behind it, a lofty and rugged krantz: mountains fill up the back-ground. The cushion is worked in silk, on black velvet: it consists of a group of wild flowers, surrounded by a wreath of vine-leaves and grapes. The lower part of the chair, below the cushion, is surrounded by a frieze: the front is carved with a wheat-sheaf, and a festoon of cobs of Indian corn. The aloe, a characteristic of South African scenery, is grouped on one side, with a stem of Kafir millet; and on the other, with Indian corn.]

- 58 WATSON, H., *St. Peter's Chambers, Cornhill.*  
Pair of polished ox horns, (with head complete,) measuring from tip to tip 8 feet 4 inches, and 21 inches in circumference—from Port Natal; and stone slab, from Natal, mounted as a table.

58A CROUCH.  
A model of machinery of H. M. S. "Dee."

- 59 WELLS, JOHN & Co., *Regent Street.*  
A slab of coloured marble, from the district of Natal, mounted on a stand of oak grown on the estate of Lord Willoughby D'Eresby; carved by the exhibitors.

- 60 BUSH, C. J., *12 Pancras Lane, London.*  
Specimen of red ebony, from Natal, with fourteen engineered draughtsmen, made from part of the same. The wood has not been dyed, but merely oiled and polished.

Elephant's tusks, found near Graham's Town. The heaviest weighs 331 lbs., the lightest 134 lbs. The longest is 8 feet 6 inches in length and 22 $\frac{3}{4}$  inches in circumference at the base, and its weight is 167 lbs.

—○○○○—  
**WESTERN AFRICA.**

SOUTH AREAS, L. M. 32.

THIS collection of articles is a very complete representation of native products and of the results of native industry. It is contributed, however, exclusively by British exhibitors interested in this colony. The raw materials are very interesting. They include specimens of woods, among which is the celebrated African teak, so extensively used for purposes of ship-building, construction, &c. Specimens of cotton, ginned and otherwise, some of which grow spontaneously on the banks of the Niger. Raw silk and other textile materials are likewise illustrated. Among the articles of food are specimens of arrow-root, coffee, shea butter, dried fruit, &c. The most interesting and extensive part of the collection consists in the textile productions of native industry, which are extremely varied, and exhibit much simple ingenuity and ornament. The baskets, weapons, and miscellaneous personal and domestic fittings shown, have also much interest attached to them individually and to the circumstances of their production.—R. E.

- 1 WESTON, WARWICK, *73 Gracechurch Street, London*—Importer.
    - 1 Teak timber or African oak, for ship building, &c.
    - 2 Ironstone. 3 Cotton with the seed.
    - 4 Cotton, cleaned, without the seed. 5 Palm oil.
    - 6—7 Bennie seed and ground nuts, from which oil is extracted
    - 8 Arrow-root. 9 The root of arrow-root.
    - 10 Shea butter. 11 Ginger. 12 Coffee.
    - 13 Pod pepper. 14 Cayenne pepper.
    - 15 Gum copal.
    - 16 African mats and small baskets, made there from dried grass.
    - 17 African country cloths, made there from their own cotton.
- These productions are all from the Western Coast of Africa.

- 2 FORSTER & SMITH.
  - Tobes, or cotton robes, from Sierra Leone.
  - Pagnes, or cotton cloths, from Gambia.
  - Knife from Gambia.
  - Grass-cloth from Sierra Leone.
  - Table-mats from Gambia.
  - Leather pouch containing MS. extracts from the Koran.
  - Leather pouches, worn as charms in Gambia.
  - Ashantee glass armlets, the glass obtained by melting European beads.

- 3 BROWN, JOSEPH PETO, *Cape Coast Castle, Gold Coast, West Africa.*  
A large silk-cotton horse-cloth, manufactured at Dahomey, Africa; worn by the king's favourite son.

- 4 ROTHERY, Miss, *10 Stratford Place, London.*  
Two large wrought-cotton counterpanes, manufactured in the Cape de Verd Islands.  
Three silk pangs, or mantles, manufactured in the island of San Nicolas, Cape de Verd Islands; worn by the ladies of the island.

- 5 TROTTER, Captain HENRY DUNDAS, R.N.  
Various articles of African growth and manufacture, purchased and chiefly manufactured at Egga, on the right

bank of the Niger; and brought to England by the Exhibitor.

1 Specimen of *Samia Aduga* raw silk. This silk can be obtained at Brini Caunatown, in the Haussa country.

2 Specimen of *Samia Aduga*, as it is manufactured at Kattam Karafi. This yellow dye is a species of arrow-root, which grows wild in some places on the banks of the Niger, and also on the coast.

3 A specimen of raw cotton, which grows spontaneously on the banks of the Niger, and is often cultivated by the natives.

4 Specimen of lime, a material made of bones burnt into ashes, mixed with water, and dried in the sun. It is used by those who spin thread for the purpose of keeping their fingers dry.

5 Poisoned arrows, such as are used by the Felatahs or Fulas, as well as by the people of Yoruba.

6 Specimen of cotton thread, including white and blue.

7 Ropes made of native hemp.

8 Female country cloth, such as is made into dresses and worn by the higher classes: it is manufactured at Yabotchy. The woollen yarn that is intermixed with the cotton is of European manufacture.

9 A goat or sheep skin.

10 Specimens of female dresses, made of country cloth: these are worn by the higher classes. They are manufactured at Iloryn, Yoruba country, and at Moko, in the Haussa country.

11 Specimens of a female fashionable dress, made of country cloth, and worn by the higher classes. The cloth is manufactured at Nikij or Babuh, in the Yoruba country. The brown cotton is taken from the silk cotton-tree, (a species of *Bombax*). This immense tree grows on the Gold Coast, and in most other parts of the west coast of Africa. The natives make their canoes, by hollowing it out and shaping it to the required size. The green leaves when just on the point of budding are very wholesome, and are used as vegetables.

12 Specimens of female dresses of country cloth, manufactured at Seluh, a town nine days' journey on foot from Nubba, situated on the left bank of the Niger.

13 Specimens of a female dress, made of country cloth, and generally worn, after having been dyed, by the higher classes as a shawl: it is manufactured at Yabotchy.

14 Specimens of female dresses, made of the country cloth which is manufactured at Kilamij and in Yoruba country.

15 Specimens of female dresses, made of country cloth, and worn by all classes. It is manufactured in Yabotchy and Yoruba.

16 Specimens of female dresses, made of country cloth, and worn by the higher classes. The red silk is to be procured only at Brini Canu: it is sold by the Arabs.

17 A variety of other country cloths, which are made into dresses, and worn by different classes. Manufactured at Yoruba, Abuna, and Egga.

18 Specimen of full-size country cloth, used for dresses by the middle classes: it is also made into counterpanes. It is manufactured at Little Popo, in the Right of Benyn. The red thread is of European manufacture.

19 Female head-bands, such as are worn by the higher and lower classes. They are manufactured at Yabotchy and Egga.

20 Specimen of a fine dress head-band, as worn by females of the higher class of people. The red silk is brought by the Arabs through the desert, from Tripoli into Haussa country, and amongst other towns, to Birmi or Brini Canu.

21 Specimen of a female head-band, 4 ft. 1 in. in length. The brown cotton is taken from the silk cotton-tree.

22 Specimens of fine and blue-glazed tobés, such as are worn by the higher class of natives. The tobé is glazed in the following manner:—After the cloth has been thoroughly dyed with indigo it is hung up until it is completely dry; it is then spread on a wooden roller, and rubbed by hand with the shell of a snail: this produces the gloss.

23 Fine plain and dyed unbleached cotton tobé.

24 Fine dress striped tobé, such as is worn by the higher classes. The yellow colour is dyed at Kattam Karafi, a town on the left bank of the Niger, a short distance above its confluence with the Chadda. The red silk is brought by the Arabs into the Haussa country.

25 Fine checked short tobé, woven with raw silk: it is worn by the higher classes.

26 Specimen of a fine checked long tobé, and Haussa trousers: it is braided with red silk about the ankles, and is made after the Turkish fashion: it is worn by the higher classes.

27 Strainer or sieve, made out of slips of bamboo: it is manufactured at Brini Canu.

28 Small earthen cooking pot and cover, earthen dishes, and stands for lamps; used by the higher classes.

29 Cushion. The red baize is of European manufacture; the yellow skin is dyed by the natives of Kattam Karafi.

30 Strings of fancy palm-nut beads, made out of burnt kernels. They are worn round the waist and neck by respectable females.

31 Coloured basket, made of bamboo; it is manufactured at Birmi, or Brini, in the Haussa country.

32 Basket to hold provisions, rice, corn, &c.

33 Calabash bowl; a wooden bowl carved out of solid wood; and calabashes of various sizes. Vessels of this kind are used for containing solid and liquid food. All calabashes are made out of a species of pumpkin, which is not edible; it has a bitter taste, similar to that of quassia. It is applied to various purposes, and is made by the natives in the Bights of Benin and Dahomey. The largest sizes are between 12 and 30 inches in diameter. They are used for conveying provisions from one place to another.

34 Specimens of wooden carved ladles or spoons.

35 Bag used for holding corn or articles of commerce.

36 Netted bag, used for exposing articles of commerce in the market-places.

37 Dahomian leather bag.

38 Carved ivory bracelet, from Egga.

39 Two mats from Egga, brought there by Richard Lander, in 1833.

5A M<sup>W</sup>WILLIAM, J. O., M.D. F.R.S. (Principal Medical Officer of the late Expedition to the Niger).

1 Specimen of shea butter, made of the fat of the *Bassia Parkii*, from Egga, on the River Niger.

[In the travels of Mungo Park frequent mention is made of *shea butter*, the product of the shea-tree. He described this tree as resembling "the American oak, and the fruit—from the kernel of which, first dried in the sun, the butter is prepared, by boiling the kernel in water"—as having "sometimes the appearance of a Spanish olive." He remarks of the butter, that it has a richer flavour than the best butter he had ever tasted made of cow's milk, and states that the growth and preparation of it seemed to be amongst the first objects of African industry, and formed one of the principal articles of the inland commerce of a large portion of the region which he traversed. Specimens of the plant, and accurate drawings, were obtained during the Niger expedition. It is a saponaceous tree, of the genus *Bassia*, allied to the Indian oil-trees and others, the fruits of which yield, on pressure, valuable oils.—E. F.]

2 Camwood dye ball, from the confluence of the Niger and the Tchadda.

3 Bow and arrows, with iron barbs, from the Icarí market, on the River Niger.

4 Felatah spear, from Kakundrah.

5 Small musical instrument from Kakundrah, on the River Niger.

6 Specimen of cloth made at the confluence of the Niger and the Tchadda.

7 Specimen of cloths from Egga and Kakundrah, on the River Niger.

8 Specimen of horn ornamented on silk, such as is worn by the females at Iddah, on the River Niger.

9 Small leathern bottles for containing the galena which is used to dye the eyelids. They were brought from the confluence of the Niger and the Tehadda.

10 Tobe, embroidered in front with needlework, such as is worn by the Mallams at Rabbah (Filatah town), on the River Niger.

11 Specimens of breeches as worn by the same.

[These articles, Nos. 10 and 11, are the property of Sir JAMES CLARK, Bart.]

12 Specimens of knitted and small scarfs from Egga.

13 Specimens of broad-brimmed straw hat, from Kinee, or Ieari Market, on the River Niger.

14 Specimens of earthenware, from Ieari Market, on the River Niger.

15 Specimens of ropes of vegetable fibre, by means of which the Africans ascend the naked trunks of the palm trees.

16 Specimens of calabash workmanship, comprehending a series of dishes of various kinds and sizes, and platters, spoons, bottles, cups, &c.

17 Pipe, from the confluence of the Niger and the Tehadda.

18 Staff of honour, such as is carried before the African chiefs.

18A Fetische from the River Congo, in the garb of a slave travelling through the country. Bag made by one of the wives of Obi, the king of Eboe: River Niger. Phosphate of lime from bones, used by the cotton-spinners to dry the tips of their fingers: at the confluence of the Niger and the Tehadda.

5B JAMIESON, JOHN, *Custom-house Agent, London.*

Mandingo cup, sword, and dagger, from the River Gambia.

Calabash and spears, brought from the Gambia.

6 HUTTON, W. B. & SON, 25 *Walling Street.*

1 Dahomey cloth, or dress; manufactured at Abomey, capital of Dahomey, and 90 miles from the sea-coast; presented by the king in 1850. The whole of the material, except the red gown, spun and dyed at Abomey. The cloth measures 5 yards by 2½ yards, and was made in a loom 5 inches wide.

2 Dahomey chief's throne and cushion; made at Abomey, capital of Dahomey, and 90 miles from the sea-coast; presented by the king of Dahomey. The stool carved out of a solid block of wood (sessaw-tree).

3 Tusk of the queen elephant.

4 Grass hat, made and worn by the natives of Dahomey.

5 Popo cloth, or dress; manufactured at Popo, on the Oil Coast. The whole of the material, except the red, grown, spun, and dyed in the country; the cloth measures 3½ yards by 2 yards, and was made in a loom 20 inches wide.

6 Basket, manufactured by the natives of Little Popo.

7 Ashantee chiefs' cloth, or dress; manufactured at Coomasey, capital of Ashantee, several miles distant (in the interior) from Cape Coast. The whole of the cotton, except the red, grown, spun, and dyed in the country; the cloth measures 4 yards by 3½ yards, and was made in a loom 3 inches wide.

8 Copper weights, used by the Ashantees for weighing gold. Cast in clay mould.

9 Powder and shot belt, made of leather, in the neighbourhood of Cape Coast.

10 Specimen of the intergrowth of two branches of different trees, from Cape Coast.

11 Dagger; made at Grand Bassam.

12 Grass-cloth; the material grown and dyed by the natives of St. Andrew's, Ivory Coast. The only article of clothing worn by the natives.

13 St. Andrew's drum, made of monkey-skin.

14 Mandingo cloth, manufactured by the Mandingos, on the River Gambia. The cotton grown, spun, and dyed in the country.

15 War-dress and sword, made and worn by the Mandingos on the River Gambia.

16 Fiddle, made and used by the Mandingos, River Gambia. Specimens of palm fruit, kernels, and oil. Specimens of palm-kernel oil, and kernel-oil soaps. Ground nuts, oil, and soap.

7 KING, R. & W., *Bristol.*

Three cushions from the king of Dahomey. Two pieces of cotton cloth of the same country.

8 FORBES, Commander F. G. (R.N.)

Two weavers' looms, chief's stool and footstool, and two lamps, from Dahomey.

Dress worn by the Amazons of the king of Dahomey. Bag manufactured at Wydah.

9 MATSON, Captain (R.N.)

Cap, as worn by the chiefs of Kabenda, Congo.

Musical instrument, with a gourd as a sounding-board, River Congo.

Fetisches, from the country on the banks of the same river.

10 MILLER, T. Esq., *Ireland*, and also of *San Nicolas, Cape de Verd Islands.*

Door-lock, as used at the Cape de Verd Islands. This lock is nearly the same as that which has been in use with the Egyptians for some forty centuries.

11 TOWNSEND, G., Esq., *Exeter.*

Specimens of cloth. A market basket. Iron bracelets. A dress, as worn by the natives. A drum. All from Abbokuta.

12 BEECHAM, Rev. Dr.

Hat and messenger's bag of Mandingo manufacture, from the Gambia.

Large Ashantee cloths. Pipes, from Coomassie.

Brass figures, used as weights.

Chief's stool and large round cushion, from Ashantee.

Cartouche box of Dahomey manufacture.

Two market-baskets, water-pot, and market-bags made of grass, from Badagry.

Specimen of raw indigo, from Abbokuta.

13 TOWNSEND, G., *Exeter.*

Various articles from Abberkutu, a town of 50,000 inhabitants, in the Yoruba country.

14 ACLAND, Lady.

Two pieces of native cloth from Abbokuta.

15 FORBES, Commander F. G. (R.N.)

Various articles from Dahomey.

16 SUTHERLAND, Her Grace the Duchess of.

Various birds, from the River Niger.

17 ACKLAND, Sir T. D. Bart., M.P.

A sword or hatchet, from Abbokuta.

18 STRAITH, Major H.

Two grass cloths from Abbokuta.

19 FADDY, Col. P., R.A., *Woolwich*.—Proprietor.

A koodoo, a harte-beest, and a water-boc (a male), killed by Captain Faddy, R.A., nearly 2,400 miles from Cape Town, in Kaffirland. The water-boc (a male) is the only specimen that has ever been brought to Europe.

## 20 FADDY, Mrs. Col.—Producer.

Gold aresbesque scarf of Fez manufacture.  
Pair of Barbary ladies' slippers.  
Vase of Barbary ware.

21 HUTTON, JAMES FREDERICK, 25 *Walling Street*—  
Importer.

African produce:—Cotton cloth, made by the slaves of the king of Dahomey, at Abomey, 90 miles in the interior of Africa. Cushion for a seat, made at the same place, and by the same people. Cotton cloths made at Popoe, on the Slave Coast of Africa, and at St. Andrew's, West. Grass cloths, for wearing round the loins. Cotton cloths, from the banks of the river Gambia. Baskets, from Popoe. The cotton of these manufactures is grown and spun in Africa by the natives; all the dyes are native, except the red.

22 JAMIESON, R., Esq., *Liverpool*.

Articles from the country on the banks of the Niger and other parts of Western Africa:—

1—4 Copper jug, &c. 7 Earthenware pot.  
10—15 Calabashes, with rings, and with spoon.  
18 Basket. 27—29 Three combs. 32 Rings.  
33 Tablet. 34—38 Five fans.  
39—41 Grass fan; specimens of antimony ore; and pepper.  
42—63 Two grass bags; peim sandals; boots; flask; brass case, earthenware, and kid skin for antimony; spurs; tin case for papers; leather knife; reaping-hook; small arms; leather wallet; string of beads; leather threads; beads.

65, 66 Two knives.

67—69 Calabash handles; leather; nuts.

79 Spear-head.

## 23 SWANZY, A., Esq.

Specimens of rock gold, from Ashantee.

24 \_\_\_\_\_  
Specimens of Dahomian cloth, from Porto Rico.

## GOLD COAST AND ASHANTEE.

A COLLECTION of a variety of articles of native production, forwarded by two exhibitors, form the contribution of this district to the Exhibition. The miscellaneous objects thus offered to view present many interesting subjects for study.—R. E.

## 1 FORSTER &amp; SMITH, Messrs.

Ashantee glass armlets, composed of glass obtained by melting down European beads. Cotton cloth prepared with native dyes. Silk cloth woven from silk threads obtained by unravelling European silk goods. Copper figures, used as gold weights by the natives—all from Ashantee.

Weaving and spinning instruments; cotton cloths; gold ornaments; pottery used for cooking; pipe heads and pipe stem; native leather; grass and mixed grass and cotton cloths—all from the Gold Coast.

## ST. HELENA.

## SOUTH AREA, Q. 32.

THIS small but interesting island, represented by four exhibitors, has sent a few specimens of its products to the Exhibition. The Agricultural Society recently established in the island, with a view to promote the cultivation of several plants which may yield a profitable return to the farmer, has forwarded specimens of

raw cotton, a box of alkali, and some rock salt. Coffee has also lately been grown on the island, and a specimen is sent for examination. Interest will be excited by a few minerals from Longwood, the residence of the Emperor Napoleon.—R. E.

1 MASSANS, SAMUEL.  
Sample of coffee grown in St. Helena.2 AGRICULTURAL SOCIETY OF ST. HELENA, per Capt.  
BOLTON, 18 *Wilton Street, Belgrave Square*.  
A box of raw cotton.  
A box of alkali, made from the Salsola plant.  
A bar of rock salt.3 MAGNUS, SAMUEL, 127 *Fenchurch Street*.  
A bag of coffee from St. Helena.4 BLOFELD, JOHN HARCOURT, 4 *Hemus Place, King's Road, Chelsea*—Producer.

Large volcanic stone taken from the wall of the Emperor Napoleon's drawing-room. Piece of stucco from the same spot, and made with the St. Helena lime, which is different to the European. Presented to the exhibitor by Captain Mason, the present leaseholder of Longwood.

Piece of limestone from the top of a hill by Sandy Bay. Lime from the kiln, at Sandy Bay. Stone impregnated with nitre, from the Red Stone Quarry, by James Town. Nine specimens of rocks.

Six petrified shells, "Bulimus," now extinct, from a stratum 1,700 feet above the level of the sea, and from a spot a little behind Longwood. Box, containing earth in which the above are found. Box, containing birds' bones, which abound in the same stratum. Also some fragile shells found in a stratum on a hill above the "Briars," and about 1,200 feet above the level of the sea.

Partially petrified birds' eggs. Similar substances abound in the stratum, which is supposed to be the remains of a bed of earth, which, at a very distant date, was the abode of numerous aquatic birds; and that this stratum (portions of which are in the boxes sent) consists of earth saturated with, and partly consisting of, the debris of their eggs, feathers, dead bodies, nests, the remains of the animals on which they fed, &c. In St. Helena, it is considered that the white substance in the stratum is the pulverized remains of the shells "Bulimus."

Three petrified shells; bivalves. Four pieces of coral from a depth of 380 feet, but within 4 feet of the shore. Three pieces of cement, painted black on the surface, from the interior sarcophagus of Napoleon's grave.

Piece of the willow tree, under which Napoleon was buried; exhibited as a vegetable production peculiar to the island.

Snuff-boxes: French polished, made from this tree; varnished, to show the wood in its plain state; and made from a willow tree which Napoleon planted behind the library at Longwood.

St. Helena cotton, with seeds. Coffee seeds and plums. Carraway branches, with seeds. One reed. Two excrescences from fir trees in the plantation at Longwood. Seeds of cow-grass. A capsicum. Part of the stem of a branch of ginger. Small branch and plums of the banyan tree. Stem and flower of the sweet-smelling geranium, from the Briars. Two sea-beans.

Buds and flowers of the "red wood;" the flowers grow in pairs, one white, the other crimson. The tree is indigenous to St. Helena. Three small pieces of Napoleon's coffin, made of this wood.

Leaves and embryo fruit of the sago pine. Branches of the "gun wood" (indigenous to St. Helena) from the avenue at Longwood. Modern shells, various. A number of the St. Helena Gazette, and of Saul Solomon's Shipping List.

## MAURITIUS.

## SOUTH AREA, Q. 31.

THAT part of the natural history of a country which is in direct relation with commerce is generally the most universally interesting, and the objects included in this collection are those which appear as its representatives in this instance. The production of raw silk is engaging much attention in the Mauritius, the natural capabilities of the land and climate appearing favourable to its prosecution. Sugar, cocoa-nuts, rice, and spices, form important articles of the commerce of the island, in addition to its export of ebony. Of sugar, a few years since this island exported to England nearly seventy million pounds in one year.—R. E.

## 1 GREY, The Countess.

Basket and wreath of flowers from the Séchelles Islands, made from the leaves of the palm of the Séchelles (*Nipa fruticans*). A nest of baskets.

## 2 DUPONT, EYENA, Esq., Port Louis—Producer.

A packet containing seven pounds of white silk, the produce of the island of Mauritius, from silkworms reared in the district of Tamarin.

[The quality of the silk must not be taken as a criterion of what Mauritius will produce, as the manufacture is in its infancy, and has only lately been commenced. About 300 acres of ground have been planted in the cooler districts of Mauritius with mulberry trees, which have rapidly grown up and are now fit for use. A company has been formed in Mauritius by the exertions of a barrister and planter there, called the "Filature Evenor Centrale." An experienced "fileuse," Madame Boildieu, has been engaged from the neighbouring island of Bourbon, and is now giving instruction to various proprietors. Some ten persons rear worms and send to the Company regular supplies of cocoons, and eighty-seven other proprietors have received cocoons and mulberry cuttings from the Company. It is considered that this manufacture will flourish and increase rapidly in the island, and form eventually an important branch of trade, the climate and the soil being peculiarly suitable to the profitable rearing

of the silkworm. From Bourbon it is stated that silk was sent to Paris of such fine quality as to fetch 111 francs per kilogramme, or about 2*l.* 4*s.* the pound.]

## 3 WEBB, CHARLES JOHN, London—Importer.

A bag of Mauritius sugar, the produce and manufacture of the Phoenix estate, obtained direct from the sugarcane expressed in a horizontal mill; the juice clarified by steam; evaporated to 27 Reaumur in common open iron pans; filtered through bags and animal charcoal; boiled in a Howard's vacuum-pan. This sugar is said not to have been re-boiled, re-made, or refined in any way, but to be pure cane sugar, without the admixture of bullock's blood or any albuminous substance, or the employment of any acetate of lead.

## 4 THE ROYAL SOCIETY OF NATURAL HISTORY OF MAURITIUS (Imported by A. STEELE, 107 Leadenhall Street).

Cases of straw baskets, rice, liqueurs, and cocoa-nut oil; a bag of cloves, a dial, and a cask of cocoa-nuts.

## 5 BALKFIELD &amp; Co., on behalf of Mad. E. CHAPON and Mdlles. GANCOURT (Importers, Messrs. S. BAKER &amp; Co., London).

Works and ornaments in straw, made on the Séchelles. Bouquets in shell-work; baskets made of leaves of the cocoa; vases, dials, &c.

## 6 MELLON, M.

Small casks of cocoa-nut oil. Woods found on the Séchelles. Specimens of sea cocoa-nuts.

A case of choice liqueurs, in 12 bottles, from the manufactory of M. Eug. Bérichon.

## 7 READER, J. S.

A case containing samples of Mauritius rice, grown on the "Champ de Mars," Port Louis, raised without any irrigation or other watering. The sack containing the sample is made of the leaves of the Vacona tree (*Oryza sativa*), the ordinary package of the colony for sugar. The soil very dry, and exposed to high and drying winds. Rice of this kind is said to possess flavour and farinaceous quality, at least equal to that exhibited in Carolina rice.

A variety of ornamental basket work from the Séchelles. A *Coco-de-mer*. Sample of cloves, &c.





IV.

BRITISH POSSESSIONS  
IN AMERICA.

CANADA.—NEW BRUNSWICK.—NOVA SCOTIA.

NEWFOUNDLAND.—BERMUDAS.

WEST INDIES.—BRITISH GUIANA.—FALKLAND ISLANDS.

EIGHT dependencies of Great Britain are enumerated under this head. Of these, the most extensive collection of articles is that from the important possessions of this country in Canada. This collection, which is more particularly characterised below, is rich in raw materials and products. The other dependencies named are represented but by few exhibitors; but the articles exhibited deserve the attention of all interested in the commercial well-being of the countries and islands represented.—R. E.

CANADA.

SOUTH AREAS, L. M. 31, and N. O. 31, 32.

THIS vast and important territory is represented in the Exhibition by about two hundred and twenty exhibitors. The articles contributed by it are distributed among several Classes, but the raw materials preponderate; and of these a highly-instructive series is presented. The efforts which have been made by the Government at home to develop the mineral wealth of this colony have been amply rewarded by the success which has attended the explorers, and the results which in some measure are brought to notice in the Exhibition. A detailed account of the geological survey and its fruits will be found in this Catalogue. Many of the minerals exhibited must take an important commercial position on their locality and means of transport becoming known and developed. Among other and in reality more precious metals, the discovery of gold in the drift of the Eastern Townships along the south-east side of the Green Mountain range will be regarded with curiosity. Some fine specimens are exhibited, one of which weighs about a quarter of a pound. Copper promises to be more available for direct commercial purposes, and a cake of this metal is sent for exhibition. In this instance the ore has been smelted in Canada. A still more important mineral is the specular iron ore, of which a most valuable and important bed exists near the waters of the Ottawa, with abundant sources of water power, and ready means of transport. Most excellent iron is obtained from the bog-iron ore, wood charcoal being employed in its manufacture: it is comparable in its qualities with Swedish iron; and the stones and cast-iron work made from it are less liable to crack than those made in this country. In addition to metalliferous minerals, the serpentine and steatite, plumbago, asbestos, and lithographic stones, promise to become valuable sources of native wealth. Of these fine specimens are exhibited.

The Canadian timber, represented by the carefully-arranged Trophy in the centre of the Western Main Avenue, is scarcely less interesting to the naturalist and merchant than the minerals. The excellent qualities of this timber for useful and ornamental purposes are illustrated in the specimens of furniture exhibited. The great futtocks for ship-building, yielded by the tamarisk tree, are likewise interesting. Timber constitutes a very prominent feature in the export commerce of the country; the white and red pine, the black walnut, maple, cedar, beech, and butter-nut, are among the more important. Among other articles of vegetable origin, the canoe, made of the bark of the white birch, will be regarded with interest. This fragile vessel has in safety made a voyage of three thousand miles, carrying a crew of twenty passengers, with their provision and other necessaries.

The agriculture of the country is largely represented. The specimens which appear in this capacity are in themselves without general interest, consisting of such articles as barrels of wheat, flour, &c.; but regarded in connection with the productive resources of the country from whence they have proceeded, they are not behind more pleasing objects in their value and attraction. The Canadian winter pastime of sleighing is illustrated by the elegant single and double sleighs sent to the Exhibition. Among the manufactures of another kind are specimens of dressed porpoise-skin and whale-skin, employed as a substitute for leather with advantage. In a comparatively new country like Canada, the manufacturing arts are still in an early stage of their development. At present her supplies of colonial produce and manufactures are derived from the mother-country: the specimens of domestic manufacture sent over to the Exhibition show the progress Canada is making in those arts; whilst the development of her great national resources is the first aim of her inhabitants. It is not, therefore, to be expected



that much attention can be given to arts that are yet in their infancy. Still the specimens sent will convey to the English artisan an idea of the field there is for the exercise of his calling. The blankets, horse-cloths, and grey *etoffe du pay*, will bear comparison with those of any country.

Among other miscellaneous objects, a piano, manufactured of Canadian woods, specially fitted to endure the changes induced by the vast change of temperature in this country, will be regarded with attention, as will also a church bell forwarded from Montreal. A very prominent object exhibited is a handsome fire-engine of great power. The alarming nature of the conflagrations occasionally breaking out in Montreal renders the possession of powerful means of extinguishing them highly necessary. This engine is capable of throwing two streams of water to a height of 160 feet each. A number of native curiosities adds to the value of this collection.—R. E.

1 LOGAN, W. E. (Director of Provincial Geological Survey)—*Montreal*.

- Specimens of magnetic specular and bog-iron ores :—
- Ilmenite and titaniferous iron.
- Sulphurets of zinc, lead, copper, nickel, and molybdenum.
- Native silver and gold.
- Bog manganese.
- Iron pyrites.
- Uran ochre.
- Cobalt bloom.
- Chromic iron.
- Dolomite and magnesite.
- Iron ochres, barytes, and other stone paints.
- Lithographic stone.
- Agate, jasper, Labradorite, and ribboned chert.
- White quartzose sandstone, for glass-making.
- Soap-stone, asbestos, plumbago.
- Phosphate of lime, gypsum, and shell marl.
- Millstone rock, whetstones, and Tripoli earth.
- Roofing slates, granite, serpentine and various qualities of marble and limestone.
- Peat petroleum and mineral pitch.

[The variety and importance of the minerals of Canada claim a more extensive notice than can usually be given. They have but recently become known; and with a view to promote a collection of them for the purposes of the Exhibition, the Executive Committee of the Canada Commission, last year, prepared a catalogue showing the localities of many of them; and from this, and the various published reports of the progress of the Canada Geological Survey, which has now been in operation under provincial authority for seven years, much information may be obtained. The country abounds in the ores of iron, consisting of the magnetic and specular oxides, and the hydrated peroxide or bog ore. The first occurs chiefly in a formation consisting of gneiss interstratified with important bands of highly crystalline limestone, and the formation sweeps through the province from Lake Huron to Labrador, keeping, at a variable distance, north from the left bank of the river St. Lawrence and its lakes, crossing the river at the Thousand Islands only, below Kingston, to form a junction with a great peninsular-shaped area of the same, occupying a mountainous region in northern New York, between Lakes Champlain and Ontario. The ore appears to lie in beds running with the stratification usually highly inclined, and the beds occasionally attain a great thickness. A bed which is now worked in the township of Marmora, and of the iron resulting from which samples have been sent, presents a breadth of 100 feet; another, the ore of which has been

mined and smelted in Madoc, has been traced several miles with a breadth of 25 feet; on Myers' Lake, in South Sherbrooke, there is a 60-foot bed; in South Crosby, a bed 200 feet in width comes upon the Rideau Canal, where it is not far removed from great water-power; and in Hull there is a 40-foot bed at no great distance from the navigable water of the river Ottawa. From all these localities, and others, specimens have been contributed, and the produce of the ore in pure metal generally ranges from 60 to 70 per cent.; that of South Sherbrooke is 63, and of Hull 69 per cent. Where the mineral has been acted on by the weather, it frequently breaks up with facility into grains related to the forms of the crystals of the magnetic iron ore, and may be easily ground and separated from earthy impurities by means of a machine in which the action of the magnet is made available. A portion of the Hull bed is in this condition; and of this bed every fathom in length by a fathom in vertical depth, taking the breadth at one-half only of what it appears to be, would produce between 50 and 60 tons of pure metal. Wood for fuel is in abundance near all the localities.

Specular iron ore appears to belong to the same geological formation; and a valuable and important bed of it occurs in the township of Maenab. It is 25 feet thick, and containing 58 per cent. of pure iron, the produce of the bed would not be under 50 tons of metal for every fathom forward by a fathom vertical; but though within a mile of the navigable water of the Ottawa, where steam-boats daily pass, and but 300 or 400 yards removed from a cascade on the river Dochart, giving ample water-power to drive machinery, the bed has never been touched for available purposes. Specular iron ore occurs also on the north shore of Lake Huron; but it is here in a formation which succeeds the gneiss, consisting of quartz rock, slates, and trap, and is noted as belonging to part of the copper-bearing region of the province.

Bog-iron ore exists in large quantities in both sections of the province. In Western Canada it prevails in the county of Norfolk, where it has been used to supply the wants of the Normandale Iron-works. It occurs in many places in the valley of the Ottawa, and specimens of it have been sent from Vaudreuil, Stanbridge, Simpson, Rivière du Chêne, St. Maurice, Portneuf, St. Vallier, and other parts, where in general it yields upwards of 50 per cent. of pure metal. That of Vaudreuil, within a short distance of the navigable water of the Ottawa, yields to analysis 76.95 per cent. of peroxide of iron, equal to 53 per cent. of pure metal, and the deposit is represented to be four feet thick. At the Forges of St. Maurice, near Three Rivers, this species of ore has been used for upwards of half a century in the manufacture of iron. The east stoves from it bear a high character through the country, being less liable to crack than the imported ones; and specimens of the wrought iron produced there have been sent to the Exhibition. The quality of the metal, wood charcoal being the only fuel used, bears a comparison with that of Sweden, and it is to compete with this that it is manufactured.

The geological formation which abounds in magnetic yields also titaniferous iron, the composition of which, at St. Urbain, in Bay St. Paul, below Quebec, is—

|                             |       |
|-----------------------------|-------|
| Oxide of titanium . . . . . | 48.60 |
| Protoxide of iron . . . . . | 37.06 |
| Peroxide of iron . . . . .  | 10.42 |
| Magnesia . . . . .          | 3.60  |
|                             | 99.68 |

This result is sensibly the same as that obtained by Rose for the titaniferous iron ore from Ilmense, in the Urals, to which he has given the name of Ilmenite. One of the masses is 90 feet wide by a visible length of 300 feet; in some parts it consists of an admixture of ilmenite and rutile; and if the consumption of the compounds of titanium in the arts should increase, the localities of Bay St. Paul might be made to furnish an inexhaustible supply. Titaniferous iron ore occurs also on the south side of the St. Lawrence, in what are termed the Eastern Townships, through which runs a continuation of the Green Mountains of Vermont. The prolongation of this range into Canada is composed of rocks belonging to the lower Silurian age, and there presents a crystalline condition from the metamorphic action of heat, displaying chloritic and talcose slates, serpentine and other magnesian forms: beds of iron ore, in general more or less magnetic, are frequently repeated among them by undulations; they prevail in the townships of St. Armand, Sutton, and Brome, where many occur varying in breadth from 2 to 15 feet, and in produce of pure iron from 20 to 50 per cent. One of 45 feet width, occurring in serpentine, in the seignory of Rigaud Vaudreuil Beauce, is a mechanical mixture of about two-thirds magnetic iron, and one-third ilmenite; and when the ore is reduced to a powder these are readily separable from one another by means of a magnet. But in general those beds which occur in the chloritic slate of St. Armand, Sutton, and Brome, contain a variable but much smaller proportion of titanic iron; and several of them have been mined, and their ores advantageously transported, by land distances of 30 and 40 miles, to smelting establishments in the State of Vermont, for the manufacture of iron. Though wood abounds in the district, none of the ores have been turned to smelting purposes in Canada.

Lead ore is met with in several parts of the province. It occurs in veins, cutting the stratified gneiss and limestone already mentioned, where the veins intersect the calcareous part of the formation, and in this relation it exists in Bedford, Bastard, and Fitzroy. In Bedford several of these veins, varying in breadth from two to four feet, have been tried, and small pits sunk upon them; but none of the mines are at present in operation. The ore occurs also in the succeeding formation, associated with copper, on the Canadian shores of Lake Superior; and in Gaspé, it is met with in Indian Cove in transverse veins, cutting a still more calcareous deposit of the upper Silurian age. As this rock is supposed to be the equivalent of the great lead-bearing formation of Wisconsin, galena may probably be expected, where the rock is found in a disturbed condition in Canada, and cut by dislocations, thereby affording an opportunity for the occurrence of lodes. The rock presents these conditions in Gaspé, but it has hitherto been but little examined. With the exception of some of the specimens from Lake Superior, silver has not been found to accompany the lead ore.

Zinc ore occurs, associated with copper and silver, on Lake Superior; but the quantity met with has not yet been sufficient to promise a profitable return.

Belonging to a formation which is interposed between the lower Silurian rocks and the gneiss, an extensive copper region occurs in Canada. From the boundary of the province at Pigeon River, it ranges along the northern and eastern shores of Lake Superior, and the north shore of Lake Huron, for a distance exceeding 400 miles. On Spar Island, in Prince's Location, a 4½-foot lode, holding vitreous copper in a gangue of calc-spar, barytes, and

amethystine quartz, cuts clay slates overlaid by greenstone trap, and yields, on the average, about 7 per cent. of pure metal. On several islands of the Archipelago, which separates Neepigon Bay from the main body of Lake Superior, native copper occurs; and on St. Ignace Island, which is the largest of them, a vein of about 2 feet, running with the stratification, has been traced the whole length of the island. Fine specimens of native copper were obtained by sinking a shaft on this lode. Many of these specimens were beautifully crystallized; vitreous copper often accompanying the native. Native copper occurs also in Michipicoten Island; and the formation of this island, and of the islands of the Neepigon archipelago, consisting of greenstone and amygdaloidal trap, interstratified with sandstone and conglomerate, is in every respect the same as that of the *Cliff*, and other mines on the south side of the lake, celebrated for the large masses of native copper which they have produced. At Mica Bay and Mamaine, the vitreous and yellow sulphurets, as well as the native copper, have been obtained. On the north shore of Lake Huron the prevailing description of copper ore is the yellow sulphuret, and the veinstone is usually quartz. The prevailing rocks of the country are greenstone trap, slate, and quartz rock, interstratified with one another; and it is in places where the lodes cut the greenstone that they become most productive, while they are least so in the quartz rock. Although lodes exist in several parts, it is only those of the Bruce mines that have been worked to any extent. In July, 1848, on a close examination of the lodes by the geological survey, a length of 300 fathoms, with a depth of 10 fathoms and a breadth of 4 feet, gave an average of 6½ per cent. of available pure metal; and 1,475 tons of vein stuff on the surface, as it had come from the lode, then sampled, gave 8 per cent. The ore has sometimes been dressed to 23 per cent., and generally to between 15 and 20 per cent., at which produces several hundreds of tons have been sent to Boston; and 200 tons, of 15¾ per cent., intended for Swansea, are now in Montreal. Smelting works have been established at the Bruce mines, and a cargo of tough cake copper shipped to the United States, one of the cakes of which has been sent to the Exhibition as a sample. The furnaces are of the reverberatory description, and the fuel used is bituminous coal, obtained at Cleveland, on Lake Erie. Wood abounds in the vicinity of the mines.

The yellow sulphuret of copper occurs at the Wallace-mine location, near White Fish River, to the eastward of the Bruce mines, in thin strings, supposed to be leaders to some main lode not yet discovered; and these are worthy of notice, from the fact that sulphuret of nickel accompanies the copper, disseminated in patches, and the nickeliferous part of the ore, when freed from earthy impurities, is found to contain 13 per cent. of pure nickel; traces of cobalt accompanying the nickel.

Copper ore occurs in the metamorphic rocks of the Eastern Townships in Upton, associated with silver, and in Ascott with silver and gold; but the quantity does not yet appear in any instance to hold out much prospect of a profit. Silver is associated with the native copper of Michipicoten and St. Ignace Islands. Native silver is also met with in small quantity accompanying the vitreous copper of Spar Island, on Prince's Location; and there is present also with it a trace of gold: cobalt occurs with them in small quantity, in the form of cobalt bloom. The lode on this location can be traced from the island to the main shore, and it then gives larger indications of silver, which is occasionally met with, associated with

blende, in thin leaves, following the cleavage joints and other crevices in the calcareous spar of the gangue. A pocket of this description, containing about 4 cwt. of good ore, gave an average produce of  $3\frac{1}{2}$  per cent., or 72 lbs. of pure silver to the ton of rock, and the commercial value of the ore in London was given as 330% per ton. Want of capital has prevented the present proprietors from prosecuting their researches; but samples of the ore, and silver smelted from it, are exhibited.

Native gold exists in the drift of the Eastern Townships, along the south-eastern side of the Green Mountain range. Its presence has been ascertained, by the investigations of the geological survey of the province, over an area comprising between 3,000 and 4,000 square miles, with a breadth of about 40 miles, from the seignory of St. Mary on the Chaudière to within 6 miles of the province line on the Kennebec road, and a length of 90 miles, from Etchemin Lake, in Cranbourne, to the vicinity of Lennoxville. It appears to be very generally disseminated in the clay and gravel of the district, but so thin as to promise little, except in occasional patches, where the drift having been washed by the action of various streams, which have worn their channels in it, the metal has been concentrated, and remains caught by the cleavage joints and various cracks and crevices of the clay slates which form the country. The localities where small quantities have been met with are too numerous to be mentioned; but selected specimens from the workings of the Chaudière Mining Company, on the Touffe des Pins, in the seignory of Rigaud Vaudreuil Beauce, have been sent to the Exhibition, weighing from a few grains to a quarter of a pound, and smaller pieces from other localities from the museum of the geological survey.

The rocks and minerals in the range of the Green Mountains, flanking this auriferous deposit, are such as are usually met with in other countries where gold occurs; and one among the minerals is chromic iron. Beds of this, of 12 to 14 inches thick, exist in serpentine, in Bolton and Ham, and yield 45 to 50 per cent. of oxide of chromium. Specimens of the ore are exhibited from both localities.

Important veins of iron pyrites occur in the seignory of Terborne and that of La Norraye and Dautraye. Wad, or bog manganese, is met with in several parts of the Eastern Townships, and traces of uranium in Madoc.

Many of the rocks and earthy minerals are worthy of attention as commercially valuable. A pure white dolomite, with 45 per cent. of carbonate of magnesia, exists in great abundance on Mazinaw Lake and in various parts of the Bathurst district in Western Canada, from which specimens are exhibited from Burgess and Blythfield. It exists also in the Eastern Townships of Lower Canada; but it is there associated with the more important rock magnesite, serving the same purposes, and containing 83 per cent. of the carbonate of magnesia. This is found in large quantities in the townships of Sutton and Bolton. Of stone paints, barytes occurs in large quantity in veins on Lake Superior, and in smaller in Bedford and Bathurst; and there exists a great abundance of iron ochres, giving various beautiful tints, allied to Sienna brown. Of these there are contributions from five different parts of the lower province. Lithographic stone, in beds of 1 to 2 feet thick, is found at Marmora, and appears to range all the way to Rama on Lake Simcoe, a distance of 70 miles. Stones of all ordinary sizes might be obtained, but no quarry has yet been opened on the beds. The specimens contributed are from Marmora, and the largest is 24 by 16 inches and 3 inches thick.

Of materials used for jewellery, agates abound on Lake Superior, on the islands of the Neepigon archipelago, and Michipicoten island; a 6-foot bed of jasper occurs at Sherbrooke, and jasper pebbles on the shores of Lake Superior and in Gaspé. Two beautiful descriptions of ornamental stone, which have been called perthite and peristerite by Dr. Thompson, but appear to be species of labradorite and aventurine, occur in Bathurst. White quartzose sandstone, fit for glass-making, exists in various parts of the province, and glass is manufactured from it at Vaudreuil and St. John. Plumbago is met with in veins of a workable size at Grenville; asbestos in abundance in Dalhousie; and large beds of pure soapstone prevail in the Eastern Townships in Potton and Bolton. Its sectile and refractory nature render it well adapted for furnace linings, stoves, baking-stones, and other forms into which it is manufactured in the neighbouring states; but though it is imported into Canada in various shapes, none of the native quarries are yet resorted to for economic purposes, with the exception of its application as foot warmers for winter journeys. The material being a slow conductor, a slab of it heated, enveloped in a blanket and placed in the bottom of a sledge under the feet, will ensure a comfortable degree of warmth to the traveller for a long distance.

The province is not deficient in mineral manures. Phosphate of lime occurs in large crystals, thickly disseminated in carbonate of lime, in extensive beds in Burgess, from which several specimens are exhibited, and in Westmeath and Hull. Gypsum prevails in flat conical masses of acres in extent, in a formation which runs along the course of the Grand River from Cayuga to Dumfries, and is mined in various places: ground at various mills it constitutes a considerable article of trade for agricultural purposes. Large blocks are exhibited from four localities in the valley of the Grand River. Shell marl is a very abundant production in numerous parts of both sections of the province. It occurs in the bottoms of ancient and of existing fresh-water lakes, and being a result from comminuted shells, is a nearly pure carbonate of lime. In four or five small lakes near New Carlisle, on the Bay Chaleur, it is composed of the calcareous remains of microscopic testacea; and, being as fine and white as flour, it has been purchased by chemists for their purposes.

Various rocks of the country, such as granite and whitish trap, and beds of silicious conglomerate in a formation called the Potsdam sandstone, afford native millstones, which are in use in many parts of the province. A rock called the gray band, at the top of the lower Silurian group, gives grindstones in Esquezing and other parts, and whetstones have been manufactured from bands of talcose slate in Madoc, Stanstead, Hatley, and Slipton. Tripoli earth, resulting from a silicious infusorial deposit, is obtained from the seignory of La Norraye and Dautraye, and from the clay cliffs in the vicinity of Montmorency. Roofing slates have been quarried in Frampton, and they occur in still untouched ground in Kingsey and Halifax, and in great abundance on the Rivière du Loup above its junction with the Chaudière. Good flagstones abound in the vicinity of Toronto and in the Eastern Townships. The chief part of the building stones of the province are of a calcareous quality, and they have been extensively used in the construction of the locks of its various ship and barge canals and the best houses of the principal cities. In the western part of the province, what is geologically

called the corniferous limestone formation, yields good stone at Amherst. The Niagara limestone, running from the great falls of that name by the upper end of Lake Ontario to Cabot's Head and the Manitoulin Islands, has been extensively worked at Thorold for the purposes of the Welland Canal, and some of the structures of Toronto. Beneath this limestone the sandstone of the gray band, already mentioned, affords excellent building stone at Hamilton. To the eastward, the Trenton limestone yields good building material from Lake Simcoe to Kingston, and from Broekville to Vaudreuil. The same formation is resorted to from Bytown to Montreal, where it has been very extensively used for the best edifices of the city; and it is also available in many parts between Montreal and Quebec. A sandstone, which underlies this, geologically designated the Potsdam formation, is quarried for building purposes at Beauharnois and several places near the mouth of the Ottawa. A beautiful white granite of superior quality for building purposes, splitting into rectangular forms, is obtained in many parts of the Eastern Townships, south of the Green Mountains. A block of this from Stanstead is exhibited. Various useful qualities of marble are obtained in Maenab, and at Grenville, Phillipsburgh, St. Dominique, and other parts; and a band of serpentine has been traced 135 miles through the Eastern Townships from Potton to Cranbourne, which promises a great variety of material suitable for ornamental architecture, but as yet no quarries are opened on it.

Peat occurs in some abundance in the flat country on the south side of the valley of the Ottawa, and in a similar district on the south side of the St. Lawrence; and specimens of it from St. Dominique, having been experimented on and analysed, show it to be a good fuel: it contains—

|                           |       |
|---------------------------|-------|
| Fixed carbon . . . . .    | 29.57 |
| Ashes . . . . .           | 6.75  |
| Volatile matter . . . . . | 63.68 |

100.

Petroleum is met with in springs in the Gaspé district, on Silver Brook, a small tributary of the River St. John, and at the mouth of this river; and naphtha is collected on the Thames River at Mosa. A bituminous deposit, in the form of mineral pitch or mineral caoutchouc, occurs in Enniskillen, in a bed of about 2 feet thick, and it is said to extend over several acres. Bituminous shale, such as is used in England for the distillation of naphtha and other products of the kind, occurs in Bosanquet, Zone, Collingwood, Port Daniel, and other places.

A great number of the mineral springs of the province have been analysed. The chief part of those of a saline character contain bromine and iodine, and some of them have traces of baryta. A copious spring in the township of Charlotteville, not far removed from Port Dover on Lake Erie, yields nearly twice the quantity of sulphuretted hydrogen contained in the celebrated Harrowgate water; and another near Brantford, with three more in the same vicinity, holds free sulphuric acid.—W. E. LOGAN, *Director of the Geological Survey of Canada.*]

2 WILSON, Dr. J., *Pertk.*

- Magnetic iron ore, from South Sherbrooke.
- Phosphate of lime, from Burgess.
- Dolomite, from Dalhousie.
- Serpentine, from Burgess.
- Pertthite, peristerite, and graphic granite, from Bathurst.

- 3 DICKSON, Mr. Sheriff A., *Packenham.*  
Speular iron ore from Macnab.
- 4 MARMORA IRON COMPANY, *Marmora.*  
Pig iron, smelted at their furnace, from the magnetic ore of the township.
- 5 FERRIER, Hon. J., *Montreal.*  
Bars of axe iron; square of bar iron; folded iron, cold; twisted iron; horse-shoe iron; ploughshare; pig of Marmora iron.  
Collection of minerals. Specimens, gypsum; specimens, geological; specimens, shell-marl.
- 6 LANCASTER, —, *Vaudreuil.*  
Specimens of bog-iron ore, and phosphate of iron.
- 7 PROULX, J., *St. Eustache.*  
Specimens of bog-iron ore, from Rivière du Chêne.
- 8 MARCOTTE, F., *Portneuf.*  
Specimens of bog-iron ore.
- 9 MORIN, Captain, *St. Vallier.*  
Specimens of bog-iron ore.
- 10 MONTREAL MINING COMPANY.  
Copper ore, from Bruce mines, Lake Huron, and tough cake copper, smelted there from the same. Native copper and silver, from St. Ignace Island, Lake Superior.
- 11 BADGLEY, J. F., *Montreal.*  
Silver ore, from Prince's Location, Lake Superior; and smelted silver from the same.
- 12 CHAUDIÈRE MINING COMPANY, *Quebec.*  
Specimens of native gold, from the workings of the Company on the Touffe des Pins, seignory of Rigaud Vaudreuil Beauce.
- 13 CLAUSSEN, CHEVALIER, *London.*  
Labradorite, from Labradore, &c.
- 14 HARWOOD, Hon. —, *Vaudreuil.*  
Specimens of black-lead from Grenville.
- 15 BOUDOIN & LEBRE, *Vaudreuil.*  
Specimens of white quartzose sandstone, such as is used in the manufacture of glass at Vaudreuil.
- 16 SEER, L. M., *St. Eustache.*  
Specimens of iron ochre.
- 17 LA BARRE, D. G., *Point du Lac.*  
Specimens of iron ochre.
- 18 HALL, J., *Melbourne.*  
Specimens of iron ochre, from Durham; and roofing slates, from Kingsey.
- 18A HERBERT, JOHN W., *Montreal.*  
Indian dress; a boudoir; pianoforte. Case of type.  
[This dress is made of cloth and ribbon cut with scissors, and sewn on with ravellings of the same material—a very difficult process. The dress consists of petticoat, jacket, and leggings, and is the costume of the chief's daughter of the Ojibbeway nation. It was entirely wrought by hand, in imitation of porcupine-work; it is all of purely Indian design and pattern. It was made and sent for exhibition by Mrs. J. H. McVey, of Potton, eastern township of Canada, who is the daughter of Charlotte Mono-nonce Kata-wa-beday, late hereditary chief of that nation, and the late Charles Oake Ermatinger, Esq., of Montreal.

The pianoforte, of six and three-quarter octave, compass from C to G, is manufactured of woods, the growth and produce of Canada, under the superintendence of the exhibitor, an Englishman of twenty-three years' residence in the city of Montreal, by workmen who acquired the principal knowledge of their trade in the manufactory of the exhibitor, whose attention to the construction of pianofortes to stand the climate of Canada, was first caused by observing that European instruments generally were unsuited to the temperature. The instrument now exhibited, both in wood and manufacture, is found, by experience, best adapted to the climate. In forwarding it, the exhibitor's object is not so much with the view of competing with countries whose facilities for manufacturing pianofortes must be admitted to be very superior to a new country like Canada, but to show the rapid improvement of the colony, and its capabilities of manufacturing what is suited to the demands of its inhabitants; and also to direct the attention of European manufacturers of these instruments to woods, the growth and produce of Canada, suitable for such purposes. The case is made of free grain black walnut-tree, veneered with crotch of the same wood; the keys are of bass-wood, the top and bottom blocks of hard Canadian maple, sounding board of Canadian spruce, which the exhibitor, by experience, is enabled confidently to state is stronger grained and superior for sound to the European wood so generally in use. The ornamental carvings are emblematical of Canada.]

- 19 CARON, E., *St. Ann, Montmorency.*  
Specimens of iron ochre.
- 19A RAHN, C., *Toronto.*  
Specimens of dentistry.
- 20 QUIGLEY, M., *Frampton.*  
Specimens of slates.
- 21 DUBERGER, G., *Murray Bay.*  
Specimens of iron ochre, from Ibberville, county of Saguenay.
- 22 KELLY, R. W., *Gaspé.*  
Specimens of iron ochre and shell marl.
- 23 YEOMANS, ASA, *Belleville.*  
Specimens of shell marl.
- 24 DE LESDERNIERES, P. T. C., *Vaudreuil.*  
Specimens of shell marl.
- 25 BOSTON, Mr. Sheriff, *Montreal.*  
Specimens of shell marl.
- 26 BOUTILLIER, Dr., *St. Hyacinthe.*  
Samples of peat.
- 27 LOGAN, J., *Montreal.*  
Barrel of fall wheat.
- 28 ALLAN, JOHN, *Long Point.*  
Three barrels of wheat.
- 29 WEESE, W. F., *Ameliasburgh.*  
Three barrels of spring wheat.
- 30 DESJARDINS, P., *Terrebonne.*  
Three barrels of spring wheat.
- 31 LAURENT, D., *Varenes.*  
Three barrels of spring wheat.
- 32 DRUMMOND, JOHN, *Petite Côte.*  
Three barrels of spring wheat.
- 33 PROVINCIAL AGRICULTURAL ASSOCIATION,  
*Canada West.*  
Three barrels of fall wheat.
- 34 GRAHAM, J., *Sydney.*  
Three barrels of fall wheat.
- 35 PROVINCIAL AGRICULTURAL ASSOCIATION,  
*Canada West.*  
Three barrels of fall wheat, raised by Mr. Christie, of Dumfries, Canada West.
- 36 TITTEMORE, G.  
Barrel of oats.
- 37 MUIR, A., *Hinchinbrooke.*  
Barrel of oats.
- 38 WATTS, R. M., *Grantham.*  
Barrel of oats.
- 39 BOA, WILLIAM, *St. Laurent.*  
Barrel of peas.
- 40 LIMOGES, D., *Terrebonne.*  
Barrel of peas.
- 41 JONES, D., *Sydney.*  
Barrel of peas.
- 42 LA MERE, Madame, *Montreal.*  
Barrel of beans.
- 43 FISHER, JAMES, *Rivière du Prairie.*  
Barrel of horse-beans.
- 44 BRIEN, J., *St. Martin's.*  
Barrel of yellow beans.
- 45 FOURNIER, C., *Longueuil.*  
Barrel of beans.
- 46 BOA, WILLIAM, *St. Laurent.*  
Barrel of barley.
- 47 DESJARDINS, P., *St. Rose.*  
Barrel of buck-wheat.
- 48 SIMPSON, J., & Co., *Bowmanville.*  
Barrel of flour.
- 49 LINGHAM, THOMAS, *Thurlow.*  
Two barrels of flour.
- 50 TAILEY, V. P., *Thurlow.*  
Barrel of flour.
- 51 SQUAIR, R., *Bowmanville.*  
Two barrels of oatmeal.
- 52 FRENHOLM, E., *Kingsey, E. T.*  
Barrel of buckwheat flour.
- 53 CANIFF, F. & T., *Thurlow.*  
Barrel of buckwheat flour.
- 54 TRENHOLM, E., *Kingsey, E.*  
Barrel of Indian meal.

- 55 RICHIER, A., *St. Laurent*.  
Barrel of Indian meal; ship-biscuit; crackers; Bologna sausages; Fletcher's candy; smoked hams; beef tongues, &c.  
[The agriculture of the Canadas is greatly influenced by the climate, and is necessarily of a peculiar character. During one-half of the year, the surface of the country is covered with snow and ice, and thus remains totally unproductive. The farmer is consequently constrained to select such plants, or varieties of plants, for his cultivation, as will perfect their growth in the brief summer of the country.  
When the ice departs, at about the end of April, vegetation commences, and proceeds with a rapidity unknown in our climate. In Upper Canada the seasons are not so severe as in Lower Canada, or the provinces of Nova Scotia and New Brunswick, and the spring sets in about a month earlier. The soil is also of a more fertile character; wheat, and indeed all the cereals, are produced in good quality, and in great abundance. The agricultural produce, however, of these colonies, is generally inferior in quality to that of more favoured climates, and the wheat being nearly all spring sown, does not command so high a rate in the markets.—J. W.]
- 56 SHAW, A., *Toronto*.  
Specimens of corn in the ear.
- 57 LOGAN, J., *Montreal*.  
Specimens of corn in the ear.
- 58 DESJARDINS, B., *St. Rose*.  
Barrel of flax seed.
- 59 FISHER, JAMES, *Rivière du Prairie*.  
Specimens of Siberian oil-seed.
- 60 UBARDEAU, S., *St. Anne*.  
Barrel of timothy seed (*Phleum pratense*).
- 61 M'GINN, T., *Montreal*.  
Barrel of timothy seed.
- 62 JEFFRIES, J., *Burodan*.  
Specimens of red clover seed and garden seeds.
- 63 SHEPHERD, G., *Montreal*.  
Various samples of garden seed.
- 64 SMITH, B., *Stanstead*.  
Bale of hops.
- 65 PENNER, J., *Lachine*.  
Bale of hops.
- 66 CENTRAL COMMISSION, *Montreal*.  
Samples of double refined and unrefined maple sugar.
- 67 BALES, JOHN, *York*.  
Specimen of double refined maple sugar.
- 68 PARKER, JOEL, *Hatley*.  
Specimen of maple sugar.
- 69 FISHER, ARTHUR, *Ascott*.  
Specimen of maple sugar.
- 70 BASTIEN, M., *St. Rose*.  
Specimens of flax.
- 71 GRICE, F., *Montreal*.  
Specimens of hemp and seed.

- 72 MACCULLOCH, DR. J., *Montreal*.  
A fungus from the pine-tree, used in Canada as a tonic bitter. It is apparently a *plyporus* allied to the *P. Officinalis* of the *Materia Medica*.
- 73 LEVEY, JOHN, *Montreal*.  
Roll of tobacco.
- 74 EGAN, JOHN, *Ottawa*.  
Plank of bird's-eye maple (*Acer saccharinum*).  
[The curled maple, so much resembling satin-wood, and the bird's-eye maple, so well known as an ornamental material, is met with where the common or sugar maple grows, but in general more on rocky ground. Sometimes they occur disseminated in single trees, and sometimes in patches of fifty or more. They occasionally are large enough to yield veneers of two feet in width; but the tree of smaller dimensions, up to 14 and 18 inches, are preferable. The large trees have often an unfigured part down the centre.]
- 75 REED & MEAKINS, *Montreal*.  
Planks of birch, cherry, pine, bird's-eye and curled maples, and butternut.
- 76 PARISAULT, J., *St. Martin*.  
Plank of chestnut.
- 77 PARISAULT, F., *St. Martin*.  
Planks of soft maple and beech.  
[The soft or sugar maple is not used to great extent in any manufacture, from being generally saved by the proprietors of the land for its yield of the material from which it takes its name. Hard maple is extensively used in the country for the manufacture of the best kinds of common furniture, and with black and red birch which are serviceable for the same purpose, is largely exported to the United States for similar objects. These three woods, also with beech, constitute the chief domestic fuel of Canada.  
Beech, in addition to its use as a fuel, affords a material for the manufacture of pyroligneous acid; and several establishments for its manufacture have lately been erected in the country. All the species of maple, birch, and beech, are spread over extensive areas in all parts of the province, and their presence is considered an undoubted mark of a good and fruitful soil.  
The butternut-tree is a sign of good dry land; and it grows frequently to a height of 12 feet. It forms one of the best materials for veneering in cabinet-work, for which it is much used, being liable to neither warp nor crack. When properly finished and stained, articles made of it can scarcely be distinguished from mahogany.]
- 78 DAVIS, J., *Simcoe, Canada West*.  
Plank of black walnut crotch.
- 79 HENSON, J., *Dawn*.  
Black walnut plank.  
Indian corn in the ear.
- 80 CENTRAL COMMISSION, *Montreal*.  
Ship-building crooks and futtocks.  
Planks and blocks—of birch; red rock elm; butternut; walnut and birch; birch and pine; bird's-eye maple; white oak; black walnut and pine; iron-wood; bass-wood and maple; soft and hard maple.  
Planks—of birch; ash; black walnut; curled ash; bass-wood; butternut; pine; tamarack; spruce; oak, &c.  
[The following description of the tree from which one

of these planks—that of black walnut—was cut, appeared in a local paper of the colony:—

“The first plank is 6 feet long and 3 feet 3 inches wide, perfect in every respect; the second plank is 4 feet long, 3½ feet wide. The length is 2 feet less than that required by the regulations: this, however, was unavoidable, for the piece has been cut to its present size for some time. The whole groundwork of this plank is a beautiful curl, traversed in every direction by large veins, which give it a very splendid appearance. The third is a veneer mounted, 4 feet long and 15 inches wide, sawn by hand from the same tree. The fourth are two magnificent crotches 5 feet long and nearly 3 feet wide. These, I am confident, would favourably compare with anything of the kind in the world.

“The colossal tree, the largest I think in this country, from which these specimens were obtained, stood in the valley of the Nanticoke, in the township of Walpole. The incidents connected with felling it and getting it into the mill are interesting. It was, I believe, in the winter of 1847, Mr. Fisher commenced operations by constructing a *shanty* for his accommodation while felling the tree and cutting it into logs. It appears almost incredible, but it is certainly the fact, that three men were busily employed a fortnight before the task was completed. The attack upon this giant of the wood was commenced about 10 o'clock A.M. by three first-rate axemen, who continued chopping that day and the next day till nearly night.

“I visited the spot shortly after: the place presented the appearance of a small windfall, so great was the quantity of timber which this huge tree crushed down in its fall. I took the dimensions of it, and if I remember correctly, they were as follow:—circumference at the ground 37 feet; 3 feet from the ground 28 feet: from this the trunk rose, tapering very little, to the height of 61 feet, when it divided into two trunks, the one nearly 6 feet in diameter, the other about 5 feet. These branches stretched up to an enormous height, reaching far above the humble trees of the forest. I could have no idea of the age of this tree, but from the smallness of the annual growths, particularly the latter ones, which were not distinguishable, I concluded it must be very old—perhaps two or three thousand years, and yet it evinced no symptoms of decay; there was not even the slightest hollow in the trunk. There were twenty-three logs in the tree, which made about 10,000 feet of timber: they would have made a much larger quantity; but, on account of the great size of some of them, they had to be hewn down considerably before they could be sawed.”

The woods of Canada are various, and some of them constitute very important articles in the commerce of the country. Among these are white pine and red pine.

The valley of the Ottawa is one of the great sources of these two species. The quantity that comes down that river is very large. The greater value of the red pine enables the lumberers to bring it from greater distances than the other, at the head of Lake Michigan; and the highest point on the Ottawa, at which it has been felled for commercial purposes, is 600 miles above Quebec, the shipping port. From this distance it requires two full months to convey the timber to Quebec; and any accident creating delay would keep it through the winter on the voyage. The highest point from which white pine is brought is 150 miles short of the other; and for the purposes of the voyage, both species are formed into enormous rafts, some of which may have a superficies of 80,000 feet. To pass down rapids it is often necessary to break up the raft into

cribs of about 10 logs each; and to obviate the difficulties of cascades, slides are constructed in many parts of the river. The largest white pine-trees of the Ottawa are used for masts, and are of sufficient measure to give planks of five feet in breadth, free from sap. The largest plank of this species is from the River Chaudière, and it measures 12 feet long by 3 feet wide, and 3 inches thick. The largest red pine-tree will give logs of about 18 inches square and 40 feet long.

White oak is another of the important commercial woods of Canada, and the chief growth is in the western part of the province. It is used in the province and elsewhere for ship-building purposes; and a form in which it is largely exported is that of staves for barrels and puncheons. One of the planks of this species sent to the Exhibition measures 26 inches in breadth.

Black walnut is a wood affording ornamented material for furniture and house-building, and is much used in Canada and the United States. The chief growth is in the western part of the province, from which it is imported largely to the United States, and its quantity is inexhaustible. For ornamental purposes, it is the crutch, at the junction of a branch with the parent stem, that is used, as in other parts the grain is straight.

Examples of the great beauty of the wood may be seen in the various articles of furniture which have been sent to the Exhibition.

The tamarisk-tree yields good material for ship-building purposes, being particularly serviceable for knees and ribs: a fine specimen of a knee is exhibited in the Trophy in the centre of the Building.

The bass or white-wood tree is also a mark of the best quality of land, and it is to be found in abundance in both parts of the province. It is much used in the panels of railroad cars, carriages, and sleighs; and for such purposes it is there considered preferable to mahogany. It is much used in the manufacture of pianos, and for the interior of cabinet-work, as well as for various domestic objects in the dairy and kitchen.

The cedar-tree, which grows to great heights, yields an excellent material for railroad sleepers, and all purposes where exclusion from the atmosphere is required. Under ground it will last for centuries. It grows always in swampy land.

Cherry-wood, like maple and beech, is used for common furniture.

White spruce is exclusively used for the construction of dwelling-houses, and being closer in the grain, and more durable than most soft woods, it is employed for plank roads. It forms a considerable branch of trade, and is largely exported both to Europe and the United States. It grows in swampy ground, and the tree sometimes attains a great height, enabling it to be used for masts and spars.

The hickory-tree is scattered through most parts of the province, and forms an ornamental tree. The wood is very tough and straight grained. It is in consequence much used for handspikes, the handles of axes, of grain cradles, and various agricultural implements, and all others where strength is required to be combined with slightness. In the form of handspikes it is an article of export to Great Britain. Samples of it may be seen in the handles of the agricultural implements which have been sent to the Exhibition.]

81 CENTRAL COMMISSION, *Montreal*.  
Specimens of maple veneer. Cross of oak veneer, and black walnut veneer.

- 82 BRAINERD, O. N., *Hamilton, Canada West.*  
Corn-whisks and dusters.
- 83 BRAINERD, O. M., *Hamilton.*  
Corn-brooms.
- 84 NELSON & BUTTERS, *Montreal.*  
Corn-brooms and whisks.
- 85 WEESE, W. F., *Ameliasburgh.*  
A ehurn.
- 86 BAILEY, J., *Sherbrooke.*  
Several pails.
- 87 DODD, ROBERT S., *Ayr.*  
A tub.
- 88 SKINNER & M'CULLOCH, *Brookville.*  
Several pronged hay-forks and manure-forks; scythe snaths.
- 89 GLASSFORD, —, *Brookville.*  
A grain cradle.
- 90 SKINNER & M'CULLOCH, *Brookville.*  
Grain-cradles.
- 91 HULBERT, SAMUEL, *Presscott.*  
A plough.
- 92 FLECK, A., *Montreal.*  
A light plough.
- 93 CENTRAL COMMISSION, *Montreal.*  
A turnip cutter.
- 94 ALLOS, J., *Montreal.*  
Specimens of calf upper and harness leather; tanning materials.
- 95 McLEAN & CUMMINGS, *Chippewa.*  
Sides of sole leather.
- 96 MURRAY, H., *Montreal.*  
Calf skins and sides of upper leather.
- 97 TEONGATHASEA, P., *Quebec.*  
Specimen of moose skin.
- 98 TOURANGEAN, P.  
Specimen of tanned moose hide.
- 99 THOMPSON, THOS., *Three Rivers.*  
Pair of moose horns (*Alus Americana*).
- 100 ALLON, J., *Montreal.*  
Tanning materials.
- 101 HOLWELL, —, *Quebec.*  
A duplex safety rein.
- 102 DEAN, R., *Montreal.*  
A patent leather travelling trunk.
- 103 BELL, P. W., *St. Catherine.*  
An Indian saddle.  
[Used by the natives in the western country when engaged in buffalo-hunting.]
- 104 WARDLE, M., *Montreal.*  
Shoe-last.
- 105 M'GILLAN & SULLIVAN, *Hamilton.*  
Hunting-saddle.
- 107 HENDERSON, J., *Montreal.*  
Bear, wolf, and fox skin sleigh robes. These costly and superb articles of out-door covering or dress are worn by the upper classes of Canadians when travelling, during the winter, in their open carriages or sleighs.
- 109 TETU, C. A., *Quebec.*  
Dressed porpoise-skin, and whale-skin leather.  
[This is beginning to be much used in place of leather, for boots and shoes; it is softer, and as durable.]
- 110 BARBEAU, J., *Quebec.*  
Fishing-boots of deer-skin leather, with whalebone stiffeners.
- 111 DANGERFIELD, —, *Montreal.*  
Pair of ladies' shoes.
- 112 CENTRAL COMMISSION, *Montreal.*  
Long and short Canadian boots.
- 113 MORRIS, R., *Montreal.*  
Set of double sleigh-harness.  
[This is intended for a double sleigh, showing the style in which the light Canadian horses are caparisoned when out on a sleighing excursion.]
- 114 MORRIS, JAMES, *Montreal.*  
A black walnut bedstead.
- 115 PATERSON, G., *Dundas.*  
Blankets and assortments of cloths.
- 115A REED & MEAKINS, *Montreal.*  
Chairs, sofas, chiffoinière, and black walnut centre-table.  
[The set of six chairs are carved in the style of the 14th century: the coverings are worked by the ladies of Montreal, who intend them as a present for Her Majesty. The sofa and chiffoinière are in the same style; the latter has the arms of the city of Montreal carved at the back.]
- 116 LAFLAMME, M. A., *Montreal.*  
Oil-cloth patterns; floor and table oil-cloth.
- 117 RAMSAY & McARTHUR, *Montreal.*  
Painted mahogany table; imitation oak table; marble table.
- 118 HAMMOND, R., *Montreal.*  
A stone centre-table.  
[The material forming this table is the limestone of Montreal. Polished in a similar manner, it is much used for chimney-pieces and other ornamental parts in architecture. It is the same stone as that of which the best edifices in the city are built.]
- 119 DUNN, W., *Quebec.*  
Embroidered chairs.  
[The seats of these chairs are embroidered in silk on leather.]
- 120 REDHEAD, THOMAS, *Montreal.*  
Black walnut office and drawing-room chairs.
- 121 ALLAN, WILLIAM, *Montreal.*  
Drawing-room chair.



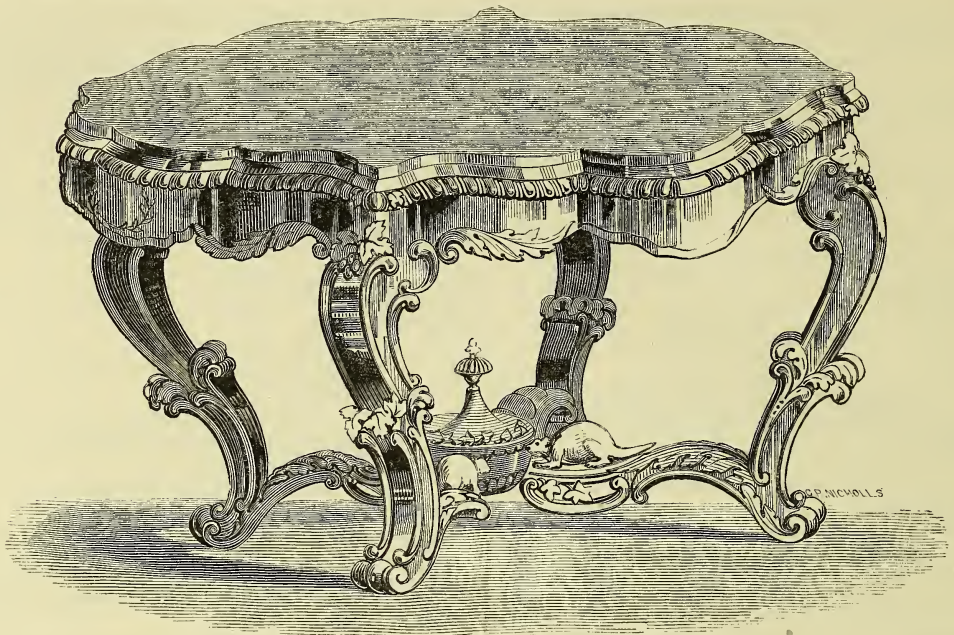

Hiltons' Walnut Centre and Pier Table.

- 123 HILTON, J. & W., *Montreal*.  
Walnut centre and pier tables. (One of these tables is represented in the above engraving.)  
Spring-back sewing-chair.  
Various chairs. Two tête-à-têtes.  
[This furniture is manufactured of the finest black walnut which Canada produces; it is delicately carved, and the seats and backs are covered with gold and crimson damask.]
- 124 MACFARLANE, A., *Côte des Niegés*.  
Samples of glue.
- 125 PRENDERGAST, J., *Montreal*.  
Samples of starch.
- 126 ROBB, J., *Montreal*.  
Box of biscuits.
- 127 FLETCHER, JOHN, *Montreal*.  
"Maiden hair" syrup. Raspberry vinegar.
- 128 BRUNSDEN & SHIPTON, *St. Hilaire*.  
Potato starch.  
Preserved potatoes, for ships' stores, especially adapted for long voyages.
- 129 PARISAULT, JOSEPH, *St. Martin*.  
Beeswax.
- 130 LEVEY, J., *Montreal*.  
Samples of snuff.
- 131 LYNAM, HENRY, *Montreal*.  
Samples of honey.
- 132 PENNER, J., *Lachine*.  
Bottled cider.
- 133 GILLESPIE & Co., *Montreal*.  
A barrel of vinegar, made from wood.
- 134 STEWART, W., *Toronto*.  
Set of single sleigh harness. Made of patent leather, lined throughout with red morocco, and exhibiting a newly-constructed self-adjusting pad.  
Barrel of ship biscuits.
- 135 FITTS, ARBA, *Montreal*.  
Fancy biscuits.
- 136 FLETCHER, JOHN, *Montreal*.  
Samples of candy.
- 137 BEAN, SYMON HARTLEY, *Canada East*.  
Woollen counterpane; table-cloths.
- 138 DIXON, T., *Toronto*.  
Woollen counterpane.
- 139 GAMBLE, W., *Milton Mills*.  
Horse blanket; pieces of carpeting; assortment of blankets.
- 140 BARBER, Messrs., *Esquesing*.  
Samples of carpeting.
- 141 FORTIER, MOSES, *St. David*.  
Piece of linen.
- 142 BEAN, SYMON, *E. T.*  
Table-cloths.
- 143 WILLETT, Messrs., *Chambly*.  
Specimen of grey cloth.
- 144 MCKAY & Co., *New Edinburgh*.  
Specimens of grey cloth; dark and brown satinette of various kinds; silk sash.
- 145 HENDERSON, H., *Montreal*.  
Embroidered table-cloth.
- 146 PATTERSON, J., *Dundas Mills*.  
Six pairs of blankets. An assortment of woollen cloths.
- 147 WALLACE, A., *Montreal*.  
Bench and moulding planes.



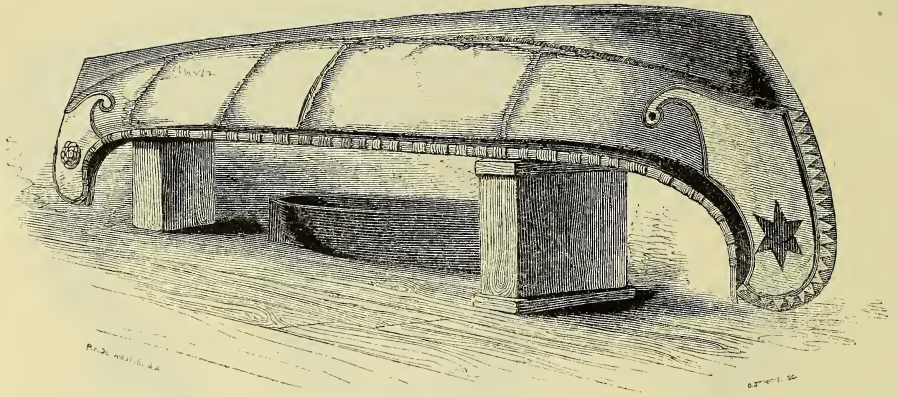

132.

A CANOE OF BARK, FROM MONTREAL.



133.

THE CANADIAN TIMBER TROPHY, SURMOUNTED BY A CANOE OF BARK.

- 148 SCOTT & GLASSFORD, *Montreal*.  
A chopping-axe.
- 149 SHAW, SAMUEL, *Toronto*.  
Chopping-axes; broad axes; coopers' tools; framing chisels; and hunting-axe.
- 150 LEAVITT, G., *Dundas*.  
Chopping and broad axes.
- 150A RICE, W. H., *Montreal*.  
Wire-cloth.
- 151 CHENEY, G. H., *Toronto*.  
A cooking-stove.
- 151A LADD, C. P., *Montreal*.  
Patent balance-scales to weigh 20 cwt.; various chopping-axes.
- 152 HOLLAND & DUNN, *Montreal*.  
Cut nails, assorted.
- 154 MOLSON, GEO. E., *Montreal*.  
A church bell.
- 155 CHENEY, G. H., *Toronto*.  
A sad-iron plate; case of types.
- 156 CHENEY, G. H., *Toronto*.  
A parlour stove.
- 157 PERRY, JAMES, *Montreal*.  
A copying press.
- 158 GARTH, CHARLES, *Montreal*.  
A steam-boat engine-gong.  
[This gong is used by the vessels in Canada in the following manner:—the gong, with apparatus, is used in the engine-room, and wires are placed from the sliding-bars which work the hammer, to the wheel-house paddle-boxes, or to any other part of the vessel: to these brass pulls are attached. Thus the captain or pilot can, by giving one or more pulls, inform the engineer whether he wishes the engine started, stopped, reversed, &c.]  
A brass double grease or oil cock, used for introducing grease or oil into the cylinder of steam-engines where high-pressure steam is used.  
A steam-boiler gauge-cock of improved construction.  
A 1-inch water-cock or valve. This water-cock is fast superseding all other kinds known in Canada.
- 159 CHENEY, G. H., *Toronto*.  
Copper furniture for a stove.
- 160 BOYD, F. J., *Montreal*.  
A cut rifle gun.
- 161 ASHFIELD, J., *Toronto*.  
A cut rifle gun.
- 162 BARTRAM, A., *Montreal*.  
A model cannon, &c.
- 163 DE MONTENAC, Madame, *Montreal*.  
City arms.
- 164 FERGUSON, W., *Montreal*.  
Flexible branch-pipes.  
[Made of bands of leather fastened together with copper rivets. It is much used in Montreal instead of the ordinary stiff pipe.]
- 165 CLARKE, JAMES, *Montreal*.  
Ship-blocks, of various sizes.

- 166 THRELKELD, —, *Toronto*.  
An assortment of whips.
- 167 WHEELER, THOMAS, *Toronto*.  
An assortment of brushes.
- 168 HENDERSON, —, *Quebec*.  
Coils of rope.
- 169 SPOONER, A., *Montreal*.  
Box of twine, assorted.
- 170 DIXON, THOMAS, *Toronto*.  
Specimens of cordage.
- 171 CENTRAL COMMISSION, *Montreal*.  
A bark canoe. (This canoe is represented in the accompanying Plate.)  
[This canoe, made from the bark of the white birch, is one of the largest class of canoes used in the north-west country. Previously to its being forwarded to England, it made a voyage in the spring of last year of upwards of 3,000 miles, with a crew of 20 men and their stock of necessaries and provisions. Being exceedingly light, the crews are enabled to carry these canoes when it is essential to avoid the falls and rapids; and, for months together, they form the homes of the hardy and daring voyagers during their transit to and from the Far West.]
- 172 ONDAGAHOUT, P.  
Pair of snow-shoes; also mocassins.  
[These snow-shoes are worn by all classes when traveling in the snow. They are used in chase of the deer and other game, by the Indians, and enable the hunter in his eager pursuit to travel over the snow at the rate of seven, and even occasionally at ten, miles an hour. Racing in them is a favourite amusement of both Canadians and Indians during the winter months; and so indispensable are they, that, without these shoes, the poorer inhabitants would be confined in stormy weather to their homes.]
- 173 BELL, P. W., *St. Catherine*.  
Indian dress, viz., coat, pair of leggings, cap, gun-case, knife-case, bracelet, and pair of small belts.  
[Formed of dressed deerskin, ornamented with dyed moose hair and beads. This dress is that of an Indian chief, made by a squaw of the Mohawk nation.]
- 174 HENDERSON, —, *Montreal*.  
Embroidered slippers, cigar-cases, purses, and fan.  
[Made by a tribe of the Iroquois Indians resident at Caughnawaya, in the neighbourhood of Montreal.]
- 175 ROCHELEAU, HELEN, *Three Rivers*.  
Bark box and fan.
- 176 CAMPBELL, Major, *St. Hilaire*.  
Bark tray and box.  
[Made of the bark of the white birch, ornamented with dyed moose hair and beads.]
- 177 INDIANS OF LORETTE.  
Indian curiosities.
- 178 M'LEAN & WRIGHT, *Montreal*.  
Single sleigh, with pole and shafts. This sleigh is represented in the following cut.

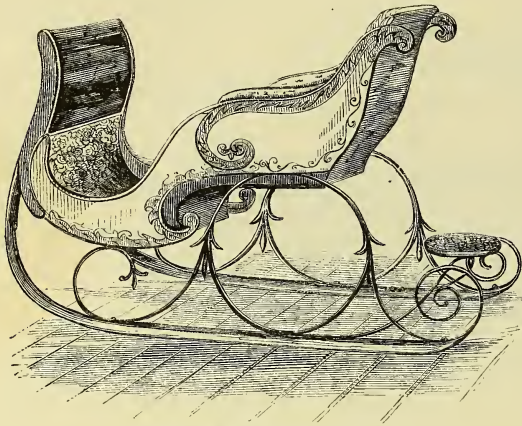

M'Lean &amp; Knight's Single Sleigh.

[This sleigh is drawn generally by four horses. Sleighing forms the chief and most highly-relished amusement of the Canadians during winter. To follow it all business is suspended; and certainly a more invigorating exercise can scarcely be imagined. Seated in one of these light and elegant carriages, wrapped in the warmest furs, ornamented with the gayest colours, and tempted abroad by a sky that equals that of Italy in brillianey, the Canadian thoroughly enjoys himself, even though the thermometer sometimes be 30 degrees below the freezing point. It is no uncommon thing to see a score or thirty of these sleighs at one time careering over the frozen snow in the "fashionable drives."]

- 179 O'MEARA, M., *Montreal*.  
A double sleigh.
- 180 LAURIN, J. J., *Quebec*.  
A single sleigh. A light carriage and wheels.
- 181 PERRY, G. J., *Montreal*.  
Fire-engine and hose reel.
- [The mechanical construction of this fire-engine differs entirely from the engines commonly used in England. Instead of working "broadside," or from end to end, this works from the ends. The usual stroke of an English engine is 8 inches: this gives one of 16 inches, while it may be worked with fewer hands, with greater facility, and consequently with less fatigue to the firemen, from 20 to 30 of whom are required to keep it in full working play; but by a simple and ingeniously contrived stuffing-box its powers may be regulated according to the number of men employed. The present engine lifts its supply of water 33 feet, playing from 50 feet of hose, one-inch bore 40 feet, and from 170 feet to 180 feet in height; or from two streams it will throw each 160 feet.]
- (This engine is represented in the Plate 48.)
- 182 JOSEPH, J. G., *Toronto*.  
A theodolite and stand.
- 183 MCPHERSON, J. & SONS, *Montreal*.  
A clarionet and a cornopean.
- 185 HIGGINS, PATRICK H.  
Violin and case, clarionet, and piccolo piano.
- 186 PARKES BROTHERS, *Toronto*.  
Various specimens of turning.

- 187 HENDERSON, —, *Montreal*.  
Case of pipes, assorted.
- 188 MATTHEWS, C., *Montreal*.  
A lithotype.
- 189 PALSgrave, J. T., *Montreal*.  
Case of type.
- 190 MEYER, H., *Toronto*.  
A lithographic drawing.
- 191 STARKE & Co., *Montreal*.  
Ornamental letter-press printing.
- 192 BUREAU & MARCOTTE, *Quebec*.  
Specimens of plain and ornamental typography.
- 193 DICKINSON, C. M., *Montreal*.  
Specimens of dentistry.
- 196 IRWIN, J., *Montreal*.  
Travelling trunk.
- [Indian curiosities, made by the native Indians of Lorette, the remains of the Herin tribe, consisting of blaek beaver and skin tobacco-pouch, card case of cunhboo feet, an Indian stool formed of moose feet, ornamented with dyed porcupine-quills and moose hair.]
- 244 LEWIS, R., *Melbourne*.  
Two model bridges.
- 301 CENTRAL COMMISSION, *Montreal*.  
Ornamental stool, moose feet. Spring-back sofa. Walnut centre tables. Walnut pick table. Spring-back sewing-chair, *tête-à-tête*. Chiffonnière. Sofa. Rocking-chair. Ordinary chairs. Wooden snow-shovels.
- 324 MANN, A., *Montreal*.  
Samples of mineral water.
- 326 NICOLSON, R., *Montreal*.  
Barrel of beef.
- 329 MATTHEWSON & SON, *Montreal*.  
Cases of fancy soaps, common soaps, and candles.
- 331 ADAMS, W. H. F., *Montreal*.  
*Etoffe du pays* suit of clothes. The capote lined with Canada tweed, the buttons of bird's-eye maple: the whole intended to show a full suit of Canadian *habitan's* dress. A fancy double coat.
- 333A STEWART, —, *Toronto*.  
Set of single sleigh-harness, lined with red moroceo, showing a self-adjusting pad.
- 334 MORRIS, R., *Montreal*.  
Military helmet. Proposed helmet of the Rangers, made for Sir James Alexander, A.D.C.; sabre-proof, the crest being stuffed with deer's-hair, and a band of whale-bone passing across the head: sun-proof, and ventilated. Weight 18 oz.
- 339 COMMISSIONERS, *Quebec*.  
Straw hats.
- 340 SAVAGE, G., & SON, *Montreal*.  
A silver embossed tea-kettle, and engraved spectacle case. Dessert and tea spoons.  
Silver table-spoon and fork.
- 341 LEGGATT, H., *Montreal*.  
Gold cable-chain and hook.  
A filigree and topaz brooch. An amethyst and a sprig brooch.

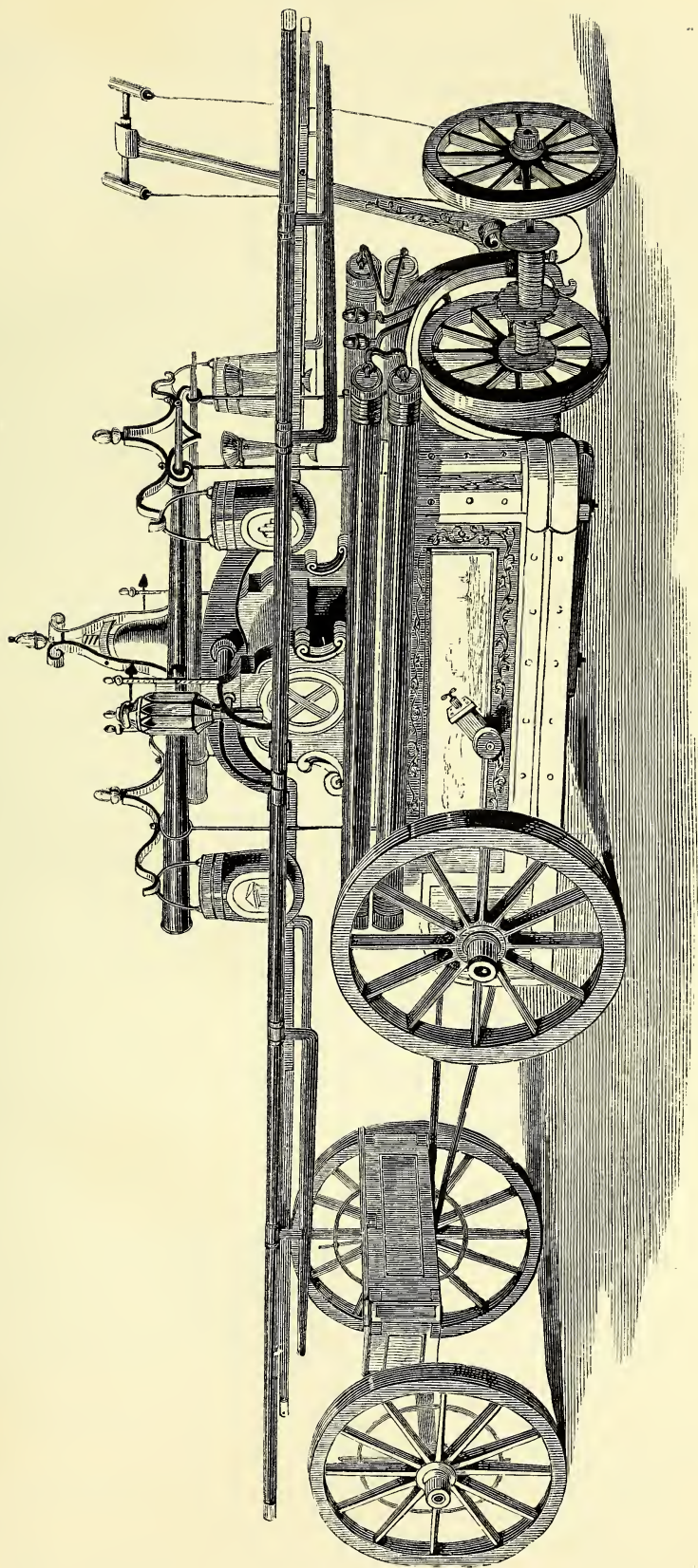

POWERFUL CANADIAN FIRE ENGINE. MESSRS. PERRY.



A snake-pin, garnet and pearl. A diamond pin. Claw-pin, ruby. Various other pins, including topaz, ball, dove, and square-head rubies.

346 RODIER, P., *St. Hyacinthe*.

A model locomotive steam-engine, gong, &c.; single sleigh; light carriage; carriage-wheels.

351 DUNCAN, J., *Montreal*.

Designs for coinage.  
Ornamental printing.

353 WHEELER, THOMAS, *Toronto*.

Medallion, in gutta pereha, of the Earl of Elgin, Governor-General of Canada, and the die from which the same was struck.

355 ASHTON, J. P., *St. Laurent*.

Specimens of the *Cottonia* plant, or wild cotton.

[This plant grows in the greatest luxuriance over almost the entire country: it has been applied successfully in Canada to the manufacture of hats, being substituted for felt; and it is generally thought, that, were it to engage the attention of the maker of English textile fabrics, he might use it to a profitable purpose.]

## NEW BRUNSWICK.

### SOUTH AREA, Q. 32.

THIS colony has sent a miscellaneous collection of raw and manufactured articles for exhibition. The timber trade of New Brunswick is represented by a series of woods; the mineral wealth by some specimens as yet undetermined, and others of iron, and probably other metalliferous ores, in addition to grindstones and stones for hones. Specimens of coal and plumbago are also sent. The agricultural produce sent consists of wheat, barley, oats, beans, &c. There are also specimens of preserved food. It is to be regretted that a fuller amount of information was not supplied with these articles, as the capabilities of the colony might have been more adequately exhibited in the Catalogue of its contributions.—R. E.

1 GREY, The Dowager Lady.

A canoe, with three figures, representing Joseph Jamar, the chief of the Melicite tribe of Indians, his squaw and her popoose, in their state costume. Sent by the Misses Close, two ladies who reside in the vicinity of the tribe.

2 GIBBS, BRIGHT, & Co., *Liverpool*—Producers.

A figure-head of an Indian chief.

3 GOULD, N., 4 *Tavistock Square, London*—Importer.

Specimens of jet coal, or asphalt, recently discovered on the banks of the river Peticodiae, Albert County, New Brunswick, and not hitherto been discovered in any other part of British America. This coal is said to produce gas of the purest colour, and in greater quantity than any other coal hitherto used for the purpose. (The property of Edward Allison, Esq., of St. John's.)  
Lump of plumbago.

4 McRAE, WILLIAM.

Bird's-eye maple.

5 MCKILLOP, A.

Bird's-eye maple.  
Curly maple (vener).

6 McRAE, WILLIAM.

Curly maple.

7 MACKIE, ALEXANDER.

Blaek birch.  
Tausoganop stones, for razor hones.

8 McRAE, WILLIAM.

Manganese (from Nassau).

9 FRASER, WILLIAM J.

Mineral (from Bay Cheleur).

10 HUTCHISON, RICHARD.

Iron ore. Mineral.

11 McCULLY, CALEB.

Mineral (from Tabusintac).

12 BLACKVILLE.

White bald wheat.

13 WYSE, JOHN.

White bald wheat, 66 lbs. per bushel.

14 BLACKVILLE.

White bald wheat.  
White bald wheat, 66 lbs. per bushel.

15 WYSE, JOHN.

Red bald wheat, 67 lbs. per bushel.

16 BLACKVILLE.

White oats.

17 WYSE, JOHN.

White oats.

18 McDERMOT, FINLAY.

Barley, 56 lbs. per bushel.

19 BROPHY, PATRICK.

Blaek oats, 41 lbs. per bushel.

20 WYSE, JOHN.

Broad beans.

21 SEARLE, MICHAEL.

Black runners.  
Speckled beans.

22 WYSE, JOHN.

White beans.  
Two copies of Professor Johnson's "Report of the Agricultural Capabilities of New Brunswick."  
Sample of Indian corn.

23

Bay or candleberry candles. Iron ore.  
Cornelian stone. Pair of mittens.  
Candleberry wax.  
Sample of grindstone, from the New-Baudon Quarry, Bay Cheleur.

24 FRASER, WILLIAM J.

Two canisters of preserved salmon.  
Two canisters of preserved lobsters.  
One canister of fresh eod-fish.

24 HUTCHISON, RICHARD.

Sample of peas, second growth, 1849.

26 SEARLE, MICHAEL.

Cabbage seed. Carrot seed.  
Parsley seed. Onion seed.

27 PORTER, J.

Bushel of beans, 68 lbs. per bushel.



- 28 GOODFELLOW, ALEXANDER.  
 Sample of white bald wheat.  
 Green peas, 68 lbs. per bushel.  
 Bushel of white beans, 68 lbs. per bushel.  
 Box containing bay or candleberry bush and sea-weed coral.  
 Sample of white bald wheat.

- 29 CHALMERS, JOHN.  
 Samples of barley, wheat, and oats.

## NOVA SCOTIA.

SOUTH AREAS, P. 30 TO 32.

THE mineral wealth of Nova Scotia forms the chief subject of illustration in this collection; and the objects exhibited prove the large extent and importance of the sources of iron of the best kind recently made available in that country. Charcoal iron is produced in considerable quantities, and is adapted for the manufacture of excellent steel. In addition to the metalliferous minerals, several others are exhibited of interest to the geologist and naturalist. The collection of stuffed birds and animals is also interesting, and is accompanied by specimens of native manufactures of the usual simple description.—R. E.

GOULD, N., 4 *Tavistock Square*.

Bitumen.

ACADIAN IRON MINING ASSOCIATION.

Iron, steel, tin plates, wire, cutlery, bars of iron and steel polished, pig and cast iron.

ARCHIBALD, CHARLES DICKSON, F.R.S., 15 *Portland Place*—Proprietor.

Iron ores from the province of Nova Scotia, embracing magnetic ores, specular, spathose, micaceous, ologistic, fossiliferous, hæmatites, hydrates, ochres, &c.

[A band of fossiliferous iron extends along the edges of the Nova Scotian coal-field from a few miles south of Pictou to Annapolis: this is usually in the state of peroxide. Ironstone balls, the argillaceous carbonate of iron, are also found interstratified with the numerous thin bands of coal of this district.—R. H.]

Manganese—peroxide, black, grey, crystallized, and acicular.

Copper ores—carbonate, oxide.

Barytes—sulphate, crystallized.

Marble—statuary, veined, &c.

Ochres—red, yellow.

Ankerite—a ferruginous variety of limestone containing spathose iron ore.

Fossils.

Various building materials.

[The iron ores of Nova Scotia are of great richness and purity. Several of the specimens above mentioned yield upwards of 70 per cent., and are entirely free from sulphur and all other impurities. They are, moreover, very abundant, and situated in the midst of vast native forests, capable of supplying charcoal to any extent, at a very cheap rate. The principal mines are within four or five miles of ship navigation; and in juxtaposition with the ores are found coal, lime, marble, freestone, fine clay, timber, water-power, and every requisite for the manufacture of iron on a large scale. The great value of these ores consists in their being essentially of a steely nature. Not only does the iron produce steel of first-rate excellence, but large quantities of steel of very superior quality have been made direct from the ores. These mines have

been opened, and a small establishment of works put in operation during the last year. The mode of reduction adopted is what is called the Catalan process, by means of which the ores are directly converted into bar iron, with charcoal fuel.]

Specimens to illustrate the proposition, "That the province of Nova Scotia is capable of supplying the whole British empire with steel and charcoal iron, equal to the best foreign articles, and at greatly reduced prices." All the enumerated articles are made from the iron and steel of Nova Scotia. Iron—cast and pig, grey, mottled, bar, rod, steel iron, horse-nail, &c., manufactured; turned specimens, polished bars, tin plate, wire, dies, &c. Steel-bars, polished, wire, &c. Manufactured articles—fenders, fire-irons, sword-blades, knives, scissors, surgical instruments, magnets, pistols, files, edge tools, razors, &c.

Working models of a steam-engine, and of a brick-making machine.

ARTICLES exhibited by the CENTRAL COMMITTEE, assigned to the care of Mr. C. D. ARCHIBALD, *Portland Place*. Agent—Mr. MACLEAN, *Lobby, Custom-house*.

Geological prints on clay. Specimens of freestone. Yellow and burnt ochre. Mineral paints. Coal. A fossil-tree. Shell, marl, and lime. Iron ore, and other mineral specimens.

Samples of cod-liver oil. Chemical preparations.

Maple-sugar in crystals; pulverized; and in syrup.

Samples of wheat grown by Indians; and grown by the farmers; weight 64 lbs. 11 oz. per bushel.

Sample of maple-sugar. Preserved fish. Digby herrings.

Barley, wheat, straw, and oats. Indian corn. Beef and ham, 90 lbs. Bacon, &c.

Specimens of woods: Curled maple, bird's-eye maple, veneered birch, grey and white oak, and lepidodendron stem.

Young seal-skins.

Specimen of human bones (Indian).

Samples of hay-seed, moose heads, and horns; cariboo.

Collection of botanical specimens.

Specimens of preserved animals, birds, and insects. The birds stuffed by Mr. Andrew Downs, of Halifax.

Skins of wild cat (*Felis catus*); lynx (*Felis lynx*); red, cross, black, silver, and white fox (varieties of *Vulpes communis* and *Vulpes lagopus*); American hare (*Lepus Americanus*); martin (*Mustela marites*); minx (*Mustela lutreola*); raccoon (*Procyon lotor*); otter (*Lutra vulgaris*); beaver (*Castor Canadensis*); bear (*Ursus Americanus*); wolf (*Canis lupus*); weasel (*Mustela erminea*); squirrel (*Sciurus*); flying squirrel (*Pteromys volucella*); silver-grey fox, martin, musquash (*Nasua socialis*); raccoon, and cat-skin sleigh robes.

Two iron castings.

One Indian canoe and three paddles.

Sample of French home-spun grey, green, striped, and plaid cloth. Check home-spun, plaid cloth, and brown cloth.

Two shawls.

Quilts, blankets, woollen hearth-rugs, &c.

Woollen vest. Socks, assorted. Mitts, assorted.

Pairs of fine and coarse pegged boots.

Shoe-lasts. Snow-shoes with moccasins.

Grass bonnets and hats. Down hat, muff, victorine, and cuffs.

An Indian dress, cradle, chairs, seats, mats, cigar cases, and other Indian work.

Map of Nova Scotia and hand-book. Book of music.

Piano, in case of bird's-eye maple.

Soap and candles. Eel-spear and fishing-rods.

Indian fan, reticule, hood, purse, and moccasins.

Indian and negro bones and baskets.

Reticules of grass.

## NEWFOUNDLAND.

SOUTH AREA, Q. 32.

THE cod-liver oil trade of Newfoundland has of late years undergone great extension, in consequence of the immense consumption of this drug for pulmonary and strumous disorders. The unquestionable instances of its successful employment give probability to the conjecture that the manufacture will receive still further increase. Cod-liver oil is used also by the preparers of leather. The inexhaustible cod fisheries off this country form in themselves a singular and interesting part of its natural history. The only contributions from Newfoundland are some samples of cod-liver oil.—R. E.

1 STABB, EWEN, *Liverpool Street, London*—Importer.

Samples of cod-liver oil, purified (of much efficacy in pulmonary complaints), from the manufactory of W. L. M'Kay, St. John's, Newfoundland.

## BERMUDAS.

SOUTH AREA, R. 32.

THE contributions of the Bermudas are placed with those of other colonies on the south of the Western Nave. The collection from this remarkable group of islands is extremely small, and consists only of a few specimens of arrow-root and palmetto plait, and some miscellaneous objects. As arrow-root and the plait of the palmetto leaf are of importance to the commerce of those islands, they will be regarded with some degree of interest as associated with their prosperity.—R. E.

GRAY, —.

Specimens of arrow-root.

JACKSON, H. H. *Bermudas*—Cabinet-maker.

Chess-board of remarkable workmanship, and exhibiting specimens of the Bermuda wood.

## SPECIMENS OF NATURAL PRODUCTIONS.

Pumice-stone.

Bermuda arrow-root.

Collection of marine productions.

Model of Bermuda sailing-boat.

Model of a hoop for a mast, for the boom to work in, instead of a "goose-neck."

Specimens of Bermuda palmetto plait.

[Arrow-root and palmetto plait form two important articles in the exports of this group of islands. The arrow-root is obtained from *Maranta arundinacea*, which is extensively cultivated in the islands, by first removing the scaly portions from the roots, and then rasping the latter and washing the powder. The fine powder obtained, after being properly dried, is packed in tins and other cases lined with paper, and exported. In 1845, it was estimated that 400,000 lbs. were made in these islands, three-fourths of which were sent to England. Bermuda arrow-root is one of the most esteemed varieties. The palmetto plait is likely to come into extensive use in this country, and is exhibited by several in a preceding Class.]

## JAMAICA.

SOUTH AREA, Q. 30.

JAMAICA is directly represented by only one exhibitor. The contribution consists of artificial flowers in imitation of the gorgeous productions of the Tropics. The material employed deserves mention. It is obtained from one of the Yuccas, plants which are members of the natural order *Liliaceæ*; and, being of tenacious fibre, are occasionally used in the manufacture of twine, rope, &c.—R. E.

NASH, MRS., *Parish of Manchester*.

Ten varieties of tropical flowers, made from the fibre of the "Yucca" or "Dagger-plant."

## BARBADOES.

SOUTH AREA, Q. 30.

A MOST complete collection of wax models has been sent from this island in illustration of tropical flowers, fruits, &c. To the naturalist, these models present a valuable opportunity for acquaintance of a more tangible character than is derivable from books, with the most valued of these productions. Among the specimens of natural produce are textile fibres, minerals, and medicinal substances, some of which are new and interesting. The sugar produced in the island is also represented by several specimens manufactured by different processes.—R. E.

MODELS AND SPECIMENS OF NATURAL PRODUCTIONS,  
FRUITS, SPICES, &c.

Cactus (*Cereus trigonus*). Dunks (*Ziziphus jujuba*). Purple peppers (*Capsicum purpureum*). Finger peppers (*Capsicum purpureum*). Sea-side grapes (*Coccoloba uifera*). Otaheite gooseberry (*Cicca disticha*). Golden apple (*Spondias dulcis*). Pig plum (*Spondias dulcis*). Water lemon (*Passiflora laurifolia*). Rose apple (*Passiflora laurifolia*). Chili peppers (*Capsicum*). Cherry peppers (*Capsicum cerasiforme*). Cashew (*Anacardium occidentale*). Red bell pepper (*Capsicum annuum*). Green bonnet pepper (*Capsicum tetragonum*). Yellow Carib pepper (*Capsicum Caribaeum*). Mango (*Mangifera indica*). Peach mango. Jamaica plum. Red bonnet pepper (*Capsicum tetragonum*). Star plums (*Chrysophyllum monospermum*). Green sugar apple (*Anona squamosa*). Purple sugar apple (*Anona squamosa*). Tamarinds. Cream-coloured peppers. Guavas. Green bell pepper (*Capsicum annuum*). Sapodilla (*Achras sapota*). Cacao (*Theobroma cacao*). Limes (*Citrus acida*). Star apple (*Chrysophyllum Cainito*). Red banana (*Musa sapientum*). Yellow banana (*Musa sapientum*). Avocado pear (*Persea gratissima*). Citron (*Citrus*). Pomegranate. Custard apple (*Anona reticulata*). Bread-fruit (*Artocarpus incisa*). Sour sop (*Anona muricata*). Green plantain (*Musa paradisiaca*). Yellow plantain (*Musa paradisiaca*). Papaw (*Carica Papaya*). Grape-fruit (*Citrus*). Sugar-cane (*Saccharum officinarum*).

Fibre of Spanish needles.

Common and Gadesden pan sugar.

Gadesden pan sugar, from Vaucluse plantation.

The fibre of the Agave Americana, and of the Agave vivipara, used in Central America for stuffing hammocks.

The "Tous les mois," and wax model of its flower.

Barbadoes cotton. Aloes.

Plant of Spanish needles.

Bituminous coal.

Selenite. Limestone.

Nicker seeds, produced by the *Guilandina Bonduac*.

[These seeds are used as a remedy for dropsical affections, and are in great repute among the native practitioners of the island. They are sent to determine whether their virtue does not depend upon some alkaloidal principle.]

The mode of administering the "horse-nicker"—the vernacular name for the seeds—is to parch the kernel, and grind it; then to infuse it, like coffee, and give a wine-glassful or more two or three times a-day. It is thought that a concentrated form of the remedy would be very valuable as a tonic or diuretic.]

Specimens of transparent sugar-cane. Bourbon sugar-cane.

Blossoms of transparent and Bourbon sugar-cane. Persian or green seed cotton. The vine cotton. Cotton from Demerara. Common Barbadoes cotton. Chalk. Quartz. Petroleum, or green tar. The bulb of the "Tous les mois."

["Tous les mois" is a variety of arrow-root, produced by a species of canna.]

## 1 READE, ALFRED, Director, Datchett.

Basket of vegetables, roots, &c., modelled in wax, by Mr. and Mrs. Braithwaite, of Barbadoes:—

Guinea corn (*Sorghum vulgare*). Pigeon peas (*Cajanus Indicus*). The Sugar-bean (*Phaseolus lunicus*). Moonshine bonavis (*Lablab leucocarpus*). Plantain (*Musa Paradisiaca*). Ginger (*Zingiber officinale*). Egg fruit (*Solanum melongena*). Arrow-root (*Maranta arundinacea*). Indian corn (*Zea mays*). Chrystophine (*Secium edule*). Cucumber, Moonshine (*Cucumis sativus*). Purple egg plant (*Solanum melongena*). Cabbage. Turnip. Carrot (*Daucus carota*). Green Indian corn (*Zea mays*). Roasting eddoes (*Arum macrorrhizum*). Cucumber (*Cucumis sativus*). Green egg plant (*Solanum melongena*). Lima bean (*Phaseolus perennis*). Turnip (*Brassica rapa*). Beet-root (*Beta vulgaris*). Pumpkin (*Cucurbita pepo*). White yam (*Dioscorea sativa*). Red potato (*Batatas edulis*). Scratching eddoes (*Caladium esculentum*). Cabbage (*Brassica oleracea*). Cassava (*Manihot utilissima*). Yellow potato (*Batata*). Bread-fruit (*Artocarpus incisa*). Red yam (*Dioscorea alata*). White potato (*Batata alba*). Madeira eddoe (*Caladium sagittifolium*). Squashes (*Cucurbita melopepo*). Bonna pepper (*Capsicum angulosum*). Carib pepper (*Capsicum*). Bell pepper (*Capsicum annuum*).

## 2 ELWELL, HENRY, Birmingham and Barbadoes.

Vase of flowers and basket of fruit; manufactured for and imported by the exhibitor. Moulded in wax by Mr. and Mrs. Henry Braithwaite, of Barbadoes.

### Flowers.

Flower fence, or Barbadoes pride (*Cesalpinia pulcherrima*). Yellow flower fence (*Cesalpinia floridus luteis*). Yellow jasmine (*Jasminum frutescens*). Tous les mois (*Canna achirras*). St. Vincent lilac (*Solanum Seaforthianum*). Murraya (*Murraya exotica*). Asclepias (*Asclepias*). Croton (*Caperonia palashis*). Citron blossom (*Citrus medica*). Plumbago, stone cold (*Plumbago*). Variegated hibiscus (*Hibiscus variegatus*). Yellow rose (*Rosa lutea*). Flesh-coloured oleander (*Nerium carneum*). Orange cordia (*Cordia fulvo aurea*). Sea Island cotton (*Gossypium hirsutum*). Crimson rose (*Rosa cruenta*). Musk ochre (*Hibiscus abelmoschus*). Blue convolvulus (*Convolvulus major*). Water lemon blossom (*Passiflora laurifolia*). Pomegranate blossom (*Punica flore-pleno*). African lily (*Amaryllis Africanus*). Hoya, or wax flower (*Hoya carnosu*). Austrian rose (*Rosa bracteata*). Common oleander (*Nerium oleander*). Wild French guava (*Cassia occidentalis*). Scarlet cordia (*Cordia sebastianu*). Poplar (*Thespesia populnea*). White rose (*Rosa alba*). Queen of flowers (*Lagerstromia regina*). Gardinia (*Gardinia flore-pleno*). Orange jasmine (*Plumieria lutea*). Painted justicia (*Graptophyllum hortense*). Lignum vitæ (*Guaiacum officinale*). Variegated jasmine (*Plumieria bicolor*). Sweet pea (*Lathyrus odoratus*). Trumpet flower (*Bignonia unguis*). Double red lily (*Amaryllis flore-pleno*). Purple bignonia (*Bignonia purpurea*). Shell plant (*Alphinia nutans*). White jasmine (*Plumieria*

*alba*). Blue vine (*Clitoria ternatea*). Barbadoes cotton (*Gossypium Barbadense*). Madeira heath (*Russelia juncea*). Changeable rose (*Hibiscus mutabilis*). Rose of Sharon (*Hibiscus flore-pleno*). Orange rose of Sharon (*Hibiscus flore-pleno luteus*). Petrea (*Petrea volubilis*). Allamanda (*Allamanda cathartica*). Verbenum (*Verbenum*). Scarlet Brownia (*Brownia coccinea*). Red jasmine (*Plumieria rubra*).

### Fruits.

Sugar-loaf pine-apple (*Ananassa sativa*). Variegated grape (*Vitis vinifera variegata*). Barbadoes cherry (*Malpighia glabra*). Barbadoes gooseberry (*Pefreshia aculeata*). Common vine grape (*Vitis vinifera*). Barbadoes sea-side grape (*Cocoloba Barbadensis*). Dunk (*Zizyphus jujuba*). Water lemon (*Passiflora laurifolia*). Lemon (*Citrus*). Common guava (*Psidium pomiferum*). Green star apple (*Chrysophyllum Jamaicense*). Gully, or hog plum (*Spondias lutea*). Tamarind (*Tamarindus Indica*). Bell pepper (*Capsicum annuum*). Rose apple (*Jambosa Malaccensis*). Jamaica plum (*Spondias mombin*). Cocoa-pod (*Theobroma cacao*). Bourbon sugar-cane (*Saccharum Otaheitense*). Cactus pear (*Cereus trigonus*). Purple avocado pear (*Persea gratissima*). Red cashew (*Anacardium occidentale*). Ribbon sugar-cane (*Saccharum rubane*). China orange (*Citrus aurantium*). Purple star plum (*Chrysophyllum monophyrenum*). Golden apple (*Joba dulcis*). Bonnet pepper (*Capsicum tetragonum*). Limes (*Citrus lima*). Green avocado pear (*Persea gratissima*). Papaw (*Carica papaya*). Pomegranate (*Punica granatum*). Green sugar apple (*Anona squamosa*). Peach mango (*Mangifera*). Plantain (*Musa paradisiaca*). Yellow banana (*Musa sapientum*). Purple star apple (*Chrysophyllum carulum*). Custard apple (*Anona reticulata*). Almona (*Terminatia calaphya*). Citron (*Citrus medica*). Purple sugar apple (*Anona squamosa rubra*). East India mango (*Mangifera indica*). French guava (*Psidium pyrifermum*). Yellow cashew (*Anacardium occidentale*). Red banana (*Musa rosacea*). Carib pepper (*Capsicum*). Mamee apple (*Mammea Americana*). Granadilla (*Passiflora quadrangularis*). Pumplenouse shaddock (*Pomplenouse decumana*). Green cocoa-nut (*Cocos nucifera*). Turkey fig (*Ficus pertusa*). Otaheite gooseberry (*Cicca disticha*). Bread-fruit (*Artocarpus incisa*). Water melon (*Cucumis citrullus*). Purple pepper (*Capsicum nigrum*). Grape-fruit (*Pompelmos racemosus*). Sapadilla (*Achrus laptilla*). Sour-sop (*Anona muricata*). Cherry pepper (*Capsicum cerasiforme*). Chili pepper (*Capsicum consideum*). Finger pepper (*Capsicum longum*). Yellow pepper (*Capsicum luteum*).

## TRINIDAD.

SOUTH AREA, R. 31.

HARRIS, Lord, Governor; Agents, LIGHTLY & SIMON, 123 Fenchurch Street; and Messrs. DANIELL, 18 Wigmore Street, London.

THE Trinidad collection is one of much value and interest. It consists, however, almost exclusively of a series of natural specimens and productions. The few manufactures exhibited are of native workmanship; they comprise sieves, baskets, ferns, and such-like articles. Attention will, however, be drawn to a model of an Indian hut, with its simple and primitive furniture: the remarkable phenomenon, the pitch lake, is represented by a variety of specimens of pitch; some taken from its centre, some from the shores, and some from the earth in its vicinity. An economical application of this substance in the manufacture of charcoal for sugar has recently been made, and may prove of value. Minerals, metalliferous ores, clays, &c., are also sent for exhibition. Tortoise-shell and whale-oil represent the animal kingdom products. Those of the vegetable kingdom are much more numerous. Among

these are spices, oils, textile materials, agricultural products, gums and resins, drugs, and lastly, woods fitted for useful and for ornamental purposes. To many of these the attention of the naturalist, nor less that of the merchant, must be directed, and the ultimate result may prove of great benefit to the island.—R. E.

#### MINERAL KINGDOM.

1. Pitch, from the springs in the centre of the pitch lake.

[The pitch lake of Trinidad is the most remarkable natural phenomenon of that island. It is about a mile and a half in circumference, and in the vicinity of volcanoes emitting mud. On the shores of the lake the pitch is perfectly hard and cold, but towards the middle it becomes softer and more fluid. The pitch has not been much used except for pavement, as it requires the admixture of a large quantity of oil.—D. T. A.]

2. Petroleum, from springs in the Guapo Hills, near the pitch lake.

3. Cellular pitch, of which the surface of the lake principally consists.

4. Compact pitch, which crops out through other strata in the lands around the pitch lake.

5. Glance pitch, found in small detached masses, in the same.

6. Pitch turf, from a pitch bog, in the same.

7 and 8. Pitch, mixed with organic matter.

9. Mineral charcoal, prepared by Mr. H. Warner, from Trinidad pitch; and used as a substitute for animal charcoal in the manufacture of sugar; it can be produced at about one-fifth of the price of the latter.

10 to 14. Petroleum, mineral oil, naphtha, ammoniacal water and coke,—prepared from Trinidad pitch, and illustrating the process of making naphtha from pitch.

Trinidad pitch has been used extensively, and with success, as a flooring for warehouses, &c., and it is likely to be exported in large quantities for the manufacture of gas.

15. Pitch seam, found between strata of sandstone.

16. Sandstone, impregnated with mineral oils and naphtha.

17 to 20. Ochres, from the Guapo Hills.

21 and 22. Sandstone, with specular iron, from the Guapo Hills.

23. Black sand, from the sea-shore at Guapo.

24. Hematite, from Gaspari island.

25. Magnetic iron ore, from Maraccas valley.

26. Iron pyrites, from the mud volcanoes.

27. Lignite, from Irois. It occurs in immense quantity, near the surface.

28. Coal, supposed to be anthracitic, from Manzanilla.

29. Slate, from St. Ann's hills; taken from the surface.

30. Honestone, from near Tamana.

31. Ochre, from Arima.

32. Clay, from Arima, used for making water jugs.

33. Earth (white), from Arima, used for white-washing houses, &c.

34. Earth (yellow), from St. Ann's river.

35. Earth (sulphureous), from near the pitch lake.

[The island of Trinidad, one of the Columbian archipelago, is about 50 miles in length from north to south and 30 miles across. A range of high ground, whose breadth is about 10 miles, runs along the northern side of the island, near the sea, and rises to the height of 1,800 to 2,400 feet, while on the south are extensive plains, also terminated by a range of hills, and at the south-west extremity are mud volcanoes. A submarine volcano exists a little south of Cape de la Brea. The pitch lake (described in another note) occupies the highest land in the island, and emits a strong smell, sensible at a distance of 10 miles. The whole island abounds with mineral oils of various kinds.

The lignite appears to be chiefly the accumulation of palm-wood. The coal is referred to, but no details of it have been forwarded.—D. T. A.]

#### ANIMAL KINGDOM.

Tortoiseshell: the hawk's-bill turtle is caught on all the coasts of Trinidad and the Gulf of Paria; the shell forms an article of export.

[This species of turtle, *Chelonia imbricata*, is readily distinguished from all others by the circumstance of the plates covering the back, overlapping each other like the tiles of a roof. These plates are much thicker, also, than those of any other species, and are more beautifully clouded. They are separated from the bone by heat, and are afterwards flattened, smoothed, and even united by their edges, by pressure at various degrees of temperature. Even the fragments and filings are capable of being rendered useful by being subject to heavy pressure in moulds, when heated to the temperature of boiling water.—T. B.]

Specimens of whale oil.

[The whale is caught in the Gulf of Paria. It usually makes its appearance about January, when the fishing season begins, and lasts till June; from 12 to 18 fish are caught annually, each giving from 60 to 80 barrels of oil.]

#### VEGETABLE KINGDOM.—(Oils and Fatty Substances.)

Cocoa-nut oil.

[A large quantity of this oil is made in the island, chiefly on the east coast, where, in one locality, there is an uninterrupted belt of cocoa-nut trees, 14 miles in extent; they usually bear nuts when five years old.]

Carap oil.

[This oil is made from the seeds of a common indigenous tree, called *Carapa guianensis*, and is highly esteemed as an unguent for the hair, for applying to the wounds of animals, for destroying ticks and other insects which infest cattle, and for the cure of rheumatism.]

Cocoa fat: this butter-like substance is obtained from the seeds of *Theobroma cacao*, and is esteemed as an emollient.

#### Spices.

Specimens of nutmegs.

[The nutmegs grown in Trinidad are considered to be equal to any from the East, as the tree thrives well in this climate. The annual produce per tree varies from 10 to 15 lbs.].

Cloves: this tree bears an abundant crop twice in the year; the produce is of good quality.

Black pepper: the plant thrives well, and is very prolific.

Cayenne pepper: the smaller kinds of capsicum (bird pepper) are very abundant, and when dried and ground, make good cayenne pepper.

Vanilla: there are three different species of vanilla, all producing this highly-aromatic pod, and all indigenous to the colony.

#### Fibres.

Specimens of cotton.

[This, although not cultivated for many years, readily suits itself to the soil and climate; the specimen sent is grown from that variety called Sea Island cotton, a few seeds of which were imported into Trinidad, in January last year, from Jamaica. The quality or staple is better than that of many other kinds. Several persons are cultivating cotton at present as a trial crop.]

Bromelia (*Karota*): this plant is indigenous to the island, and, like all the pine-apple tribe, furnishes a strong and soft fibre.

*Sterculia* (*Caribæa* or *Majaqua*): the bark of this tree furnishes the country people with cordage, and is strong.

Agave (*Vivipara* or *Langue bœuf*): all the species of agave furnish a white, but somewhat harsh or brittle fibre.

#### AGRICULTURAL PRODUCTS.

Specimens of sugar (*Muscovado*).

[This is the staple product of the colony, and great exertions are being made to improve its quality. Mr. H. Warner, of this island, has succeeded in making a white muscovado sugar (by a peculiar process with mineral charcoal, made from the pitch of Trinidad), boiled in open pan; the specimen sent is a sample by this process.]

Specimen of rice.

[This article is productive in any part of the island, whether the land be high or low; its cultivation is not unhealthy in Trinidad, as in drier climates, where the land must be rendered swampy, for its successful cultivation.]

Specimens of cassava starch.

[These are the produce of *Jatropha manihot* (or bitter cassava). This plant is extensively cultivated. Few plants give so great return for the amount of labour bestowed on it; it forms the chief bread-stuff of the lower classes. Cassava cakes are made from its grated roots; the pulp is placed in a strainer (culebra), and after the poisonous juice is expressed, it is baked on a hot pan; they resemble oat-meal cakes in appearance. The starch is obtained from the smaller particles which pass through the strainer in a state of solution: it is then allowed to subside, and the water is separated from the starch, which is dried in the sun. This water is boiled down to a thick syrup: in the course of this operation its poisonous properties disappear, and it then forms the well-known West Indian sauce—Casaripe.]

Arrow-root: the produce of *Maranta arundinacea*, and other species. This plant produces abundantly.

Tous les mois, or tulema: the produce of *Canna coccinea*.

[This, as well as the former, gives a large return of starch. It is said that the produce per acre, in good soil, is equal to that of sugar from the sugar-cane, viz., from one to two tons per acre. The starches from both plants are manufactured in a similar manner: the thick fleshy corns are washed and passed through a series of rollers, then stirred rapidly in large vats, in order to precipitate the starch, which is afterwards washed several times, and dried in the sun.]

Brazil nuts: the produce of *Bertholettia excelsa*. The tree has been introduced from South America, and is ornamental and useful.

Tonquin bean: the tree, *Dipterix odorata*, was introduced from British Guiana.

Indian corn, or maize.

Coffee (Mocha): this variety of coffee has been introduced some years, and preserves, in cultivation, its peculiarly small round grain.

Theobroma, cacao, or cocoa: this tree is extensively cultivated; its produce forms a large article of export. The soil and climate of Trinidad combine to make it very productive. The annual export of late years has been above 4,000,000 of pounds.

Cocoa, or chocolate, manufactured.

Tobacco, in the leaf, from Siparia.

Tobacco, manufactured, from the same place.

#### Gums and Resins.

Gun anime: from Arima, the produce of *Hymenæa courbaril*.

Incense: the produce of *Trichilia trinilensis*.

#### Medicinal Products.

Sarsaparilla: the produce of *Smilax*, and abundant.  
Ginger.

#### Tanning and Dyeing Materials.

Turmeric, logwood, and fustic.

#### Woods for Ornamental and other Purposes.

*Hymenæa courbaril*, or locust: a valuable timber, and abundant, which grows from two to six feet in diameter.

Yoke: a handsome wood, analogous to mahogany, usually from two to three feet diameter.

*Cedrela odorata*: West Indian cedar; a useful and ornamental timber, from three to twelve feet in diameter.

*Rhopala montana* (*Aguatapaná*): a wood very durable, and taking a fine polish; growing from 18 inches to 3 feet in diameter.

Tapana: used for felloes of wheels, and where strength and toughness are required.

*Cordia* (or *Sepe*): a useful light wood, analogous to English elm in texture, and possessing a bitter principle obnoxious to insects; from one to two feet in diameter.

*Acaras* (*Balata*): a timber much used; from two to six feet in diameter.

*Achras* (*Acoma* or *Mastic*): like the timber of the whole family of Sapotacæ much valued; from two to four feet in diameter.

*Achras* (*Zapotilla* or *Zapodilla*).

*Astrocaryum aculeatum* (*Gri gri*): this, like most of the palm tribe, furnishes good material for veneering.

*Acrocomia sclerocarpa* (*Gru gru*): a wood similar to the last.

*Carapa guianensis* (or *Carapa*): a useful timber, analogous to cedar; from two to three feet in diameter.

*Bucida buceras* (or *Olivia*): a strong useful wood, commonly used for making shingles; from two to four feet in diameter.

Purple heart: an abundant and useful timber, from two to four feet in diameter.

Fustic: used for all purposes where strength is required, and as a dyewood; from one to three feet in diameter.

*Lecythis* (*Idatamon* or *Aguatacaro*): commonly used as shafts for carts, &c.; a tough wood of large size, and very common.

*Tecoma serratifolia* (*grey poui*); *Tecoma* (*black poui*); *Tecoma* (*green poui*).

[These bigoniacous trees furnish hard and durable woods; their timber takes a fine polish, and has a peculiar colour; they furnish the most useful timbers of the colony; they are very abundant, and of large size, from three to four feet in diameter.]

*Brosimum guianens* (*Letter-wood*): the heart wood is the only part used, and is never of any great size.

*Crescentia cujete* (or *calabash*): furnishes a timber applicable to the same purposes, as that of the ash in England; it is used for boat-building; is very tough; and a common tree in the woods; about two feet in diameter.

*Geoffroya inermis* (or *l'Angeline*); a timber much employed as naves for wheels and other purposes.

*Paltiva*. Bois gri (or *iron-wood*).

*Mimosa juliflora* (*Yoke savañ*); a hard and useful wood.

Roble: a common and excellent wood, from two to three feet in diameter.

*Copaifera officinalis* (*Copaï*): is an ornamental and lasting wood.

*Vitex capitata*: this tree is reckoned durable timber, and is very common.

Bois lizard—*Guaiaicum officinale* (*Lignum vita*): very hard wood, about one foot in diameter.

#### MANUFACTURES, ORNAMENTAL SEEDS, &c.

Sieve, made of a species of *Maranta*, for sifting cassava meal.

Culebra, for expressing the cassava pulp, and extricating the cassava starch.

Calabashes (carved).

Fans, for ladies.

Fish-basket, as used by the Indians.

Seeds (ornamental): seeds used for beads of different kinds, viz., *Adenantha pavonina*, *Coix laehryma*, *Erythrina corallodendron*, *Ormosia dasycarpa*.

[Of the plants which furnish seeds adapted for beads, the *Coix laehryma* is a tropical grass, indigenous in the East Indies—introduced into the West Indies. Its seeds, or, more properly, fruits, are hard and stony, and have a beautiful pearly lustre; they are popularly known as Job's Tears. The others are leguminous plants, whose seeds, properly so called, are remarkable for hardness and beauty. *Erythrina corallodendron* is a member of the kidney-bean group; *Adenantha pavonina*, a tree of the mimosa tribe, is often called "red sandal-wood;" *Ormosia dasycarpa* is the necklacc-tree; its seeds are of a most brilliant red hue, with a black eye.—E. F.]

Model of an Indian hut, in the village of Arima, 16 miles from the town of Port of Spain, made by Manuel Sorzano.

Its contents are as follow:—

- |                                                                                                                                                                                                                         |                                                                                       |
|-------------------------------------------------------------------------------------------------------------------------------------------------------------------------------------------------------------------------|---------------------------------------------------------------------------------------|
| 1 Arco—Bow.                                                                                                                                                                                                             | 39 El trago—The grog.                                                                 |
| 2 Flechas—Arrows.                                                                                                                                                                                                       | 40 Gato—Cat.                                                                          |
| 3 Ponda—Fishing Net.                                                                                                                                                                                                    | 41 Perro—Dog.                                                                         |
| 4 Taparos—Long calabashes used for keeping honey, &c.                                                                                                                                                                   | 42 Anoto—Anoto used for cooking.                                                      |
| 5 Casabas—Casada made of manioc.                                                                                                                                                                                        | 43 Abispero—Jack Spaniard's nest.                                                     |
| 6 Taralla—Cast net.                                                                                                                                                                                                     | 44 Comejen—Wood lice.                                                                 |
| 7 Trapiche—Used for pressing sugar-canes to extract the juice.                                                                                                                                                          | 45 Escova—Broom.                                                                      |
| 8 Anseuleador—Fishing-rod.                                                                                                                                                                                              | 46 Garabato—Hook.                                                                     |
| 9 Escusa—Kept over fire-place to preserve provisions by smoke.                                                                                                                                                          | 47 Cuero de gato tigre—Tiger-cat's skin.                                              |
| 10 Hoya—Cooking-pot.                                                                                                                                                                                                    | 48 Cama—bed.                                                                          |
| 11 Casuela—Dish.                                                                                                                                                                                                        | 49 Troja del viego—Old man's bed.                                                     |
| 12 Topias—Stones on fire-place.                                                                                                                                                                                         | 50 Estera—Mat.                                                                        |
| 13 Hacha—Axe.                                                                                                                                                                                                           | 51 Chinchorro—Hammock.                                                                |
| 14 Guayare—Basket carried on the back.                                                                                                                                                                                  | 52 Old Indian pascual.                                                                |
| 15 Pionilla—Indian bead.                                                                                                                                                                                                | 53 Ynes—Indian woman.                                                                 |
| 16 Chosa—Bird-trap.                                                                                                                                                                                                     | 54 Canuto—Indian child.                                                               |
| 17 Banco—Bench.                                                                                                                                                                                                         | 55 Tiramba—Used as a Jew's harp.                                                      |
| 18 Machete—Cutlass.                                                                                                                                                                                                     | 56 Butaque—Easy chair.                                                                |
| 19 Platanos—Plantains.                                                                                                                                                                                                  | 57 Arepas—Corn bread.                                                                 |
| 20 Piedra de Moler—Grinding-stone for making arepas (Indian corn-cake).                                                                                                                                                 | 58 Totumas—Calabashes.                                                                |
| 21 Totuma de Moler—Calabash receiving the corn.                                                                                                                                                                         | 59 Cuero de Benaó—Deer-skin.                                                          |
| 22 Cuchillo—Knife.                                                                                                                                                                                                      | 60 Pecho de Piapoco—Tocan's skin.                                                     |
| 23 Paleta—Washerwoman's beetle.                                                                                                                                                                                         | 61 Guareguare—Fan.                                                                    |
| 24 Canasto—Basket.                                                                                                                                                                                                      | 62 Pala—Shovel.                                                                       |
| 25 Lena—Wood for fuel.                                                                                                                                                                                                  | 63 Chicora—Used for digging holes.                                                    |
| 26 Trojita—Used as a table.                                                                                                                                                                                             | 64 Piedra de Movejón—Stone for grinding cutlasses, &c.                                |
| 27 Naza de Poso—Fish-pot for deep water.                                                                                                                                                                                | 65 Cucharas—Spoons.                                                                   |
| 28 Naza de Corriente—Fish-pot for strong streams.                                                                                                                                                                       | 66 Azadon—Hoe.                                                                        |
| 29 Sebucan—Used for extracting the poisonous juice of the manioc for the purpose of making casadas, a juice which is called catara (castirpe), and when boiled loses its poisonous effect, and makes a very good sauce. | 67 Rayo—Grater.                                                                       |
| 30 Molenillo—Swizzle-stick.                                                                                                                                                                                             | 68 Tirite, Maranta (species of)—(outside of the stem of).                             |
| 31 Yesquero—Tinder-box.                                                                                                                                                                                                 | 69 Mamure, <i>Carludovica scandens</i> (aerial roots of).                             |
| 32 Pilon—Mortar.                                                                                                                                                                                                        | 70 Camuare, <i>Desmonchus Orycanthus</i> (scandent stem of).                          |
| 33 Bandola—A sort of guitar.                                                                                                                                                                                            | 71 Cerima—Pothos (species of).                                                        |
| 34 Batea—Tub.                                                                                                                                                                                                           | 72 Maraca—Bangle or Chac-chac used for dancing, accompanied by the bandola or guitar. |
| 35 Chirguas—Water-jars.                                                                                                                                                                                                 | 73 Chaguarama—Used as a mat ( <i>Azeca oleracea</i> ).                                |
| 36 Mapipe—Basket.                                                                                                                                                                                                       | 74 Cortadera—( <i>Scleria</i> , species of).                                          |
| 37 Manare—Sieve.                                                                                                                                                                                                        | 75 Timie— <i>Manicaria saccifera</i> (leaf of).                                       |
| 38 Gallo—Cock.                                                                                                                                                                                                          | 76 Cachipo leaves—( <i>Maranta</i> , species of).                                     |
|                                                                                                                                                                                                                         | 77 Pabilo—Wax-taper.                                                                  |

[The Indians of Trinidad were of the section of Caribs known as Yanoi. Like other members of the Carib race, the pure breed is scarcely, if at all, existing now. The greater number of articles enumerated in the preceding

list, as contents of an Indian hut, are of Spanish or of modern West Indian origin; so are the terms applied to them. Of the vegetable substances exhibited, several, as well as several utensils, concern the cassava, or cassada, a valuable article of food in the West Indies. It is prepared from the roots of the *Manihot utilisima*, or *Jatropha manihot*, a shrub of the spurge tribe. The large roots of this plant are full of poisonous juice, but when rasped, washed, and heated, the remaining substance is the nutritive cassava, and the starch is tapioca. Of other vegetables mentioned, the *Carludovica scandens* is a plant of the *Pandanus*, or serew-pine tribe; the *Desmoncus* is a spiny palm; the *Areca oleracea* is the famous West Indian cabbage-palm, of which the terminal bud furnishes a valuable and delicious article of food; the *Manicaria* is also a palm; the *Scleria* is a kind of sedge; the *Pothos* a plant of the *Arum* tribe; and the various kinds of *Maranta* are arrow-root plants. The "Jack Spaniard" is a kind of wasp.—E. F.]

## A N T I G U A.

SOUTH AREA, Q. 30.

GREY, The Countess.

Fossil wood from Antigua, sent home by Governor Higginson.

## S T. V I N C E N T.

SOUTH AREA, Q. 30.

One exhibitor from St. Vincent has sent contributions to the Exhibition. The articles forwarded consist of vegetable materials employed in basket-making, and for coarse textile purposes.—R. E.

BULLOCK, G., *St. Vincent*.

A selection of supple-jacks.

Arooma, as it grows. Arooma prepared by the Caribs for making baskets.

Mahant as it grows; the bark being the part used.

Mahant bark unprepared.

Mahant bark prepared for twisting into fishing-lines.

Lapeto in the raw state.

Lapeto prepared to be worked.

Lapeto in fine and coarse lines, for fishing, being very strong for the purpose.

## B A H A M A S.

SOUTH AREA, R. 31.

Six exhibitors only appear to represent these islands at the Exhibition. Their contributions relate exclusively to the products of the vegetable and animal kingdoms, and of those only a very small number are exhibited. The models of fruit in wax form an interesting series, and represent with fidelity some of the most highly-esteemed vegetable delicacies of western produce. Yucca hemp and palmetto stuff are likewise exhibited. The beautiful white and coloured vases of shells, gathered from the shores of the Bahamas, are very attractive objects. Specimens of West India sponge and timber are also found among other articles.—R. E.

BARNETT, MRS. EDWARD, of *Nassau*, and 14 *Woburn Square, London*—Producer.

Specimens of Fruits in Wax:—

- 1 Bread-fruit (*Artocarpus incisa*).
- 2 Plantain (*Musa sapientium*).
- 3 Coeo plum (*Chrysobalanus icaco*).
- 4 Prickly pears (*Cactus opuntia*).
- 5 Banana (*Musa paradisiaca*).

- 6 Cashew (*Anacardium occidentale*).
- 7 Spanish pepper (*Capsicum annuum*).
- 8 Star-apple—showing the interior (*Chrysophyllum cainito*).
- 9 Papaw (*Carica papaya*).
- 10 Spanish plum (*Spondias chrysobalanus*).
- 11 Goosberry (*Cicca disticha*).
- 12 Water-lemon (*Passiflora laurifolia*).
- 13 Aquii.
- 14 Sugar-apple (*Anona squamosa*).
- 15 Balsam (*Impatiens noli me tangere*).
- 16 Star-apple (*Chrysophyllum cainito*).
- 17 Fig (*Ficus carica*).
- 18 Sugar-cane (*Saccharum officinarum*).
- 19 Banana—showing the interior (*Musa paradisiaca*).
- 20 Sour sop (*Anona muricata*).
- 21 Guava (*Psidium pyrifera*).
- 22 Custard-apple (*Anona reticulata*).
- 23 Cherry (*Cordia alliodora*).
- 24 Guava—showing the interior (*Psidium pyrifera*).
- 25 Sapodilla—showing the interior (*Achras zapota*).
- 26 Hog-plum (*Spondias myrobala*).
- 27 Bread-fruit—showing the interior (*Artocarpus incisa*).
- 28 Mango (*Mangifera indica*).
- 29 Avocado pear—cut to show the interior (*Persea gratissima*).
- 30 Banana—red (*Musa paradisiaca*).
- 31 Fig banana (*Musa coccinea*).
- 32 Sapodilla (*Achras zapota*).

THOMPSON, JOHN THOMAS, *Nassau*—Producer.

Specimens of Yucca hemp prepared by the exhibitor:—

- A One leaf of the Yucca (*Serrulata*).
- B The billets between which they are packed cut from the flower-shaft.

[This cork-like material is of use where softness and elasticity are required in bedding, or stuffing, or packing different sorts of work; in bodies of razor-strops. In thick or thin sheets, it is very convenient for purposes where points have to be fixed and withdrawn easily, such as cases for entomological purposes.]

- C Hemp prepared from the Yucca leaf.
- D Rope prepared from the hemp, but stained in soaking.
- E The same of the natural colour.

Specimens of palmetto stuff:—

- 1 Leaves of the palmetto.
- 2 Fibre prepared from the leaves.
- 3 Rope completed.

NICOLLS, Miss CAROLINE, *Nassau*—Producer.

Crown and pedestal of shell work.

GRANT, Miss, *Nassau*—Producer.

Vase manufactured of the mimosa bean.

BARNES & Co., *Nassau*—Producers.

Case of specimens of different varieties of West Indian sponge.

Specimens of woods, including satin-wood, horseflesh, mahogany, commonly called Madeira, horseflesh mahogany, cedar, crab-wood, log-wood, stopper-wood, and lignum vitæ.

GREIG, The Misses, *Nassau*—Manufacturers.

An epergne composed entirely of shells, forming cornucopias filled with flowers, in great variety of colour and beauty: the whole of the shells were gathered from the shores of the Bahamas. (*Consignees*, Messrs. DANIELL, 18 *Wigmore Street, London*.)

A large vase, with group of flowers, composed entirely of pure white shells.

A figure in a fancy costume, of shell-work.

(Forwarded by Governor Gregory to J. B. Cameron, Esq.)

## GRENADA.

SOUTH AREA, R. 30.

TAPIOCA and nutmegs form the only articles representing Grenada at the Exhibition. These prove by no means the most important articles of export from this island; but one of them, nutmegs, is interesting as being of recent introduction into cultivation.—R. E.

GROSE, HENRY, 12 *Coleman Street, London*—Importer.

Tapioca: prepared from the roots of the cassava plant, and forming a highly-nutritious article of food. The plant is extremely prolific and easy of cultivation.

Nutmegs: introduced into the island by Mr. Kennedy, in 1827. The export to the United Kingdom amounted in 1850 to 1,400 lbs.

## MONTSERRAT.

SOUTH AREA, Q. 10.

Two articles only appear to represent Montserrat: these are both articles of food.—R. E.

A box of maize or Indian corn.

A box of arrow-root.

## ST. KITT'S.

SOUTH AREA, R. 30.

THIS island is represented by one exhibitor, a native black labourer. The contribution furnished is a fishing-utensil, made out of the inner bark of a tree.—R. E.

A West Indian fish-pot, made by John Morris, a black labourer, in the Island of St. Christopher, from the inner bark of a tree.

It is usually baited and weighted, and then sunk to the depth of eight or ten fathoms. A buoy marks the spot, and it remains about twelve hours in the water.

## BRITISH GUIANA.

SOUTH AREA, R. 32.

ABOUT one hundred and sixty exhibitors appear to represent this most interesting colony. The contributions forwarded belong almost exclusively to the first section of the classification of the Exhibition. There are a few specimens of native manufactures in wood and woven work, as the shaak-shaak, used to make a noise in the dances; the singular baskets used by Indian women to carry their children in, fly-brushes, baskets made of the cabbage-palm, fans of the eta palm, &c. But these exhibit simply that neat but rude and simple industry which, with little or no elaboration of the raw material, produces implements and ornaments from the most convenient substances yielded by nature. The articles in the first four Classes are extremely valuable and interesting, not only to the naturalist, but also in a commercial point of view. The arrow-root, starches, tapioca, coffee, cotton, sugar, and timber, abundantly yielded by plants in this prolific colony, are well represented. Several of the contributions are experimental in their tendency, and have been made with a view to learn the probability of the development of a commercial demand for these articles. The timber of this colony will probably ultimately become valuable in commerce. Several medicinal products are likewise exhibited.—R. E.

CATALOGUE of ARTICLES, the Produce of BRITISH GUIANA, a colony on the coast of SOUTH AMERICA, comprising the counties of DEMERARA, BERBICE, and ESSEQUEBO, exhibited by ALEXANDER F. RIDGWAY, 42 Leicester Square, London, Agent to the Royal Agricultural and Commercial Society of the Colony.

POLLARD, T. M.

1 White sand, from Mount Pleasant, Warratilla Creek, River Demerara.

[This sand has been exported to the United States of America for the purpose of glass-making.]

2 Red sand, from Warratilla Creek, River Demerara.

DUGGIN, T. B.

3 White sand, from Monte Video, River Berbice, about 200 miles above its estuary.

4 Oreala, a decomposed rock, from River Berbice, supposed to be valuable in the manufacture of pottery.

[The rocks yielding the materials of ordinary pottery are of the granitic and porphyritic series. The agency of slow but continued decomposition, by atmospheric gases and water, causes the separation of their hard materials, and their resolution into a soft friable mass, now often called porcelain clay. This decomposition affects the felspar composing these rocks. The rock in question is in all probability a felspathic rock.—R. E.]

BEE, J. F.

5 Clays and sands, from an Artesian boring, and obtained at various depths.

[These clays and sands were obtained at various depths from an Artesian boring. This boring, 4 inches in diameter and 118 feet in depth, on Plantation Woodlands, one mile from the mouth of the Mahaica River, was executed between 6th and 22nd October, 1849, by Mr. John Allt. The water is delivered 18 inches above the surface of the soil, and is greatly increased in quantity by the flood of spring tides, like all other Artesian borings of the colony. The following memorandum was taken during the process of boring:—1 to 5 feet, surface soil; 6 feet, layer of caddy; 7 to 9 feet, blue clay; 9 to 39 feet, soft mud mixed with caddy, in which the auger went down by its own weight; 39 to 53 feet, rotten wood and pegass, or decayed vegetable matter; 53 to 55 feet, bluish-grey clay, stiff; 55 to 57 feet, clay, a little red and grey; 57 to 70 feet, reddish clay; 70 to 82 feet 10 inches, yellowish-grey clay, with a little sand and ochre, very stiff; 82 feet 10 inches to 86 feet 8 inches, bluish-grey clay, streaked; 86 feet 8 inches to 92 feet, bluish-grey clay, streaked, more yellow. The bed of sand from which the water is obtained was reached at a depth of 118 feet, and the same stratum was found at a depth of 125 feet. The numbers on the 31 specimens sent indicate the depth in feet at which they were obtained.

There are a considerable number of Artesian wells in this colony: the water is not, however, pure. It contains a large quantity of oxide of iron, held in solution by carbonic acid. This separates as a yellow deposit on exposure of the water to the air.—R. E.]

NETSCHER, A. D. VAN DER GON.

6 Rice, from Plantation Klein Pouderoeyn, River Demerara.

DUGGIN, T. B.

7 Rice, from Monte Video, River Berbice.

[The colony of British Guiana is eminently favourable for the cultivation of rice. It is worthy of remark, that three crops can be obtained *annually* in this colony from

*one sowing*, the new crop ratooning or springing up from the old roots after each reaping.]

NETSCHER, A. D. VAN DER GON.

8 Maize, or Indian corn, from Plantation Klein Pouderoeyn, River Demerara.

[The maize (*Zea mays*, Lin.) grown in British Guiana, commands a higher price in the market than that imported from the United States of America, from which the chief supply is derived.]

9 Meal from maize, or Indian corn, from Plantation Klein Pouderoeyn, River Demerara.

10 Plantains, unripe, sliced and dried without the aid of fire, from Plantation Klein Pouderoeyn, River Demerara.

[The plantain (*Musa paradisiaca*) has frequently been suggested as an article of export. In its ripe state, no unexceptionable and sufficiently cheap method of preserving it has yet been suggested. It is sometimes so abundant and cheap that it might, if cut and dried in its green state, be exported with advantage. It is in this unripe state that it is so largely used by the peasantry of this colony as an article of food. It has always been believed to be highly nutritive; but this is scarcely justified by analyses.

When dried and reduced to the state of meal, it cannot, like wheat flour, be manufactured into macaroni or vermicelli, or at least the macaroni made from it falls to powder when put into hot water. The fresh plantain, however, when boiled whole, forms a dense firm mass, of greater consistency and toughness than the potato. This mass, beaten in a mortar, constitutes the *foo-foo* of the negroes. The plantain meal cannot be got into this state unless by mixing it up with water to form a stiff dough, and then boiling it in shapes or bound in cloths.]

11 Plantain meal, or konkin tay, from Plantation Klein Pouderoeyn, River Demerara.

[Plantain meal is prepared by stripping off the husk of the plantain, slicing the core, and drying it in the sun. When thoroughly dry, it is powdered and sifted. It is known among the Creoles of the colony under the name of *Conquin-tay*. It has a fragrant odour, acquired in drying, somewhat resembling fresh hay or tea. It is largely employed as the food of infants, children, and invalids. As food for children and convalescents, it would probably be much esteemed in Europe, and it deserves a trial on account of its fragrance, and its being exceedingly easy of digestion. In respect of nutritiveness, it deserves a preference over all the pure starches on account of the proteine compounds it contains.

The flavour of the meal depends a good deal on the rapidity with which the slices are dried; hence the operation is only fitted for dry weather. Above all, the plantain must not be allowed to approach too closely to yellowness or ripeness, otherwise it becomes impossible to dry it. The colour of the meal is injured when steel knives are used in husking or slicing, but silver or nickel blades do not injure the colour. Were the plantain meal to come into use in England, and bear a price in any way approaching to that of Bermuda arrow-root, it would become an extensive and very profitable export. Full-sized and well-filled bunches give 60 per cent. of core to 40 of husk and top-stem, but in general the core does not much exceed 50 per cent., and the fresh core will yield 40 per cent. of dry meal, so that from 20 to 25 per cent. of meal is obtained from the plantain, or 5 lbs. from an average bunch of 25 lbs.; and an acre of plantain walk of average



quality, producing during the year 450 such bunches, would yield a ton and 10 lbs. of meal.]

DAVISON, WILLIAM.

12 Plantain meal, from Plantation Vigilance, East Sea Coast, Demerara.

GARNETT, H. T.

13 Plantain meal, from Plantation Herstelling, River Demerara.

14 Meal from the bitter cassava, from the same plantation, baked into bread.

[This substance affords a remarkable exemplification of the agency of heat in destroying or dissipating the pernicious properties of some vegetable products. The juice of the root of the cassava plant, or mandioc plant (*Manihot utilissima*), is extremely venomous, and produces rapid death. Yet the root, when rasped and washed and baked, is not only wholly innocuous, but proves a nutritious article of vegetable diet. This fact appears to be a part of the universal experience obtained by the natives of every district where it is found. The process of its preparation for use has been thus described:—

“It is usually conducted as follows:—The squeezed pulp is broken up, sifted, and exposed to the sun on trays or mats till it is fully more than half dry. An iron hoop of the size and thickness of the cake to be made is then laid on a girdle or hot plate, and the space within the hoop is filled evenly with the somewhat moist meal, no previous kneading or rolling having been employed. As soon as the coarse meal coheres, the ring is lifted and the cake is turned and heated on the opposite side. The heat should not be sufficient to brown the cake. The cakes are finally dried by exposure to the sun. From the dry cassava meal cakes may be prepared by sprinkling it with as much cold water as to moisten it to the proper point, and then proceeding as above. Hot water cannot be employed, neither can kneading, or any considerable degree of compression be used, otherwise the water does not evaporate readily enough, the starch gets too much altered by the heat, and the cake becomes tough.”—*Dr. Shier's Report on the Starch-producing Plants of British Guiana.*—R. E.]

DE PUTRON, J.

15, 15a, 15b Bananas, dried without the aid of fire, from Plantation Vigilance, East Sea Coast, Demerara.

[The banana is yielded by *Musa sapientum*, Lin. These specimens are sent in order to ascertain the likelihood of their standing the voyage, and becoming an article of export. They were prepared in the month of September, 1850. The following information regarding the banana is extracted from a popular source:—“Eight or nine months after the sucker has been planted, the banana begins to form its clusters, and the fruit may be collected in the tenth or eleventh months. When the stock is cut, the fruit of which has ripened, a sprout is put forth, which again bears fruit in three months. The whole labour of cultivation which is required for a plantation of bananas, is to cut the stalks laden with the ripe fruit, and to give the plants a slight nourishment once or twice a year by digging round the roots. A spot of little more than a thousand square feet will contain from 30 to 40 banana plants. A cluster of bananas, produced on a single plant, often contains from 160 to 180 fruits, and weighs from 70 to 80 lbs. But reckoning the weight of a cluster only at 40 lbs., such a plantation would produce more than 4,000 lbs. of nutritive substance. Humboldt calculates that as 33 lbs. of wheat and 99 lbs. of potatoes require the

same space as that in which 4,000 lbs. of bananas are grown, the produce of bananas is consequently to that of wheat as 133 to 1, and that of potatoes as 44 to 1. The banana ripened in the hot-houses of Europe has an insipid taste, but yet the natives of both Indies, to many millions of whom it supplies their principal food, eat it with avidity, and are satisfied with the nourishment it affords. This fruit is a very sugary substance, and in warm countries the natives find such food not only satisfying for the moment, but permanently nutritive. Yet weight for weight, the nutritive matter cannot at all be compared with that of wheat, or even potatoes. At the same time a much greater number of individuals may be supported upon the produce of a piece of ground planted with bananas, compared with a piece of the same size in Europe growing wheat. Humboldt estimates the proportion as 25 to 1; and he illustrates the fact by remarking that a European newly arrived in the torrid zone is struck with nothing so much as the extreme smallness of the spots under cultivation round a cabin which contains a numerous family of Indians.” It may be proper here to notice that the banana is cultivated in this colony to a very limited extent, and used solely as a fruit in its ripe state. The plantain, on the other hand, is extensively cultivated, and in its unripe state is the staple and favourite food of the Creole and African population of the colony.]

NETSCHER, A. D. VAN DER GON.

16 Coffee, from Plantation Klein Pouderoeyn, River Demerara.

KENNEDY, JOHN.

16a, 16b Pearl coffee, from Plantation Nooit Gedacht, Canal No. 1, River Demerara.

BEE, J. F.

17, 18 Coffee in the husk, and in the berry, from Georgetown, Demerara.

[The quantity of coffee, the produce of British Guiana, returned for taxation in 1842, amounted to 1,214,010 lbs. Dutch. The cultivation is now almost extinct. Nos. 16a and 16b are from one of the few estates which have been and still continue to be cultivated solely as coffee plantations.]

NETSCHER, A. D. VAN DER GON.

19 Cocoa seeds, from Plantation Klein Pouderoeyn, River Demerara.

[Cacao, or cocoa (*Theobroma cacao*, Lin.) was never extensively cultivated in this colony, although the soil and climate are well adapted for its production.]

DUGGIN, T. B.

20 Saouari nuts, from River Berbice.

[Saouari nuts (*Pekea tuberculosa*, Aubl, or *Cayocar tomentosum*, Dec.) The kernel of this nut is one of the most delicious fruits of the nut kind known. It abounds in the forests on the banks of the rivers of the colony.]

OUTRIDGE, J. ESQ.

20a Seed-vessel of the “monkey pot,” from the River Demerara.

[This seed-vessel is said to contain a large number of oleaginous kernels.]

SHIER, DAVID.

21 Capsicums, dried capsules.

22, 22a Capsicums, preserved in dilute acetic acid.

23 Capsicums, active principle extracted by olive oil.

24 Capsicums, active principle extracted by vinegar, all from Plantation Kitty, East Sea Coast, Demerara.

[These capsicums, known in the colony under the name of Buckramami peppers, are the most pungent and aro-

matic of the whole tribe. The seeds, which are inert, have been removed, and the dried capsules are sent in the expectation of their being found to be a more piquant condiment than the article sold under the name of Cayenne pepper.]

STUTCHBURY, J. S.

25 Capsicums, preserved in dilute acetic acid, from Georgetown, Demerara.

DUGGIN, T. B.

26 Fruit of a shrub, called birambi, from River Berbice, preserved in pickle.

[This fruit makes a delicious preserve.]

NETSCHER, A. D. VAN DER GON.

27 Limcs (*Citrus lima*), from Plantation Klein Poudroyen, River Demerara, preserved in pickle.

STUTCHBURY, J. S.

28 Kasareep, the inspissated juice of the bitter cassava, from Georgetown, Demerara.

[Kasareep, from the *Jatropha manihot*, is much used as the basis of sauces, and is used extensively in the colony in the preparation of pepper-pot, &c. Dr. Shier, in the Report referred to, notices it as follows:—"To those who have never visited the tropics, it may be proper to notice that *casareep* is the concentrated juice of the roots of bitter cassava, and the basis of the West Indian dish pepper-pot. One of its most remarkable properties is its high antiseptic power, preserving any meat that may be boiled in it for a much longer period than can be done by any other culinary process. Casareep was originally a Buck or Indian preparation, and has often been described with more or less accuracy." It is well known that some of the Dutch planters of this colony have, by means of the addition of a small quantity of casareep, from time to time, to varieties of animal food, been enabled to keep up, in daily use, the same *pepper-pot* for many years.]

BEE, J. F.

29 Kasareep, the inspissated juice of the bitter cassava, from Georgetown.

DE PUTRON, J.

29a Saline ash; in appearance similar to a black cinder. [This ash is obtained by burning certain plants growing on the rocks near the Rapids, about 1,000 miles up the River Demerara. The salt is extracted when required by mixing water with the ash, and after the insoluble parts have subsided, pouring off the solution and using it as salt. A similar saline ash is also said to be obtained by burning the Ita palm.]

STUTCHBURY, J. S.

30 Turmeric root, from Georgetown, preserved in dilute acetic acid.

[The Turmeric (*Curcuma longa*, Lin.) grown in this colony is superior to any imported.]

GARNETT, H. T.

31 Arrow-root, from Plantation Herstelling, River Demerara.

[The produce of *Maranta arundinacea*, Lin.]

32 Starch, from the bitter cassava, from Plantation Herstelling, River Demerara.

[When the roots of the cassava plant are rasped and washed in water, a large quantity of starch granules are extracted from the vegetable tissue, and float in the water. The water charged with these granules is allowed to stand, when the granules settle down, and the superabundant fluid is poured off. The starch is then collected and dried.—R. E.]

SHIER, DAVID.

33 Starch, from the sweet cassava, from Plantation Kitty, East Sea Coast, Demerara.

[The sweet and bitter cassava merit attention as starch-producing plants. The sweet cassava yields 26·92, and the bitter 24·84 of starch per cent. They are occasionally grown for this purpose in the colony, and yield a large percentage of starch; but there exists an opinion, whether well or ill founded, that it is liable to rot linen, and the preference is given here to the starch of arrow-root. Cassava grows readily in any soil, and, with good drainage, two crops of the sweet variety are yielded per year. It grows luxuriantly in the light soils of the interior, as well as in the stiff clay soils of the coasts. It is considered an excellent preparatory crop in new and stiff land, on account of its tendency to loosen the soil.]

34 Starch, from the plantain, from Plantation Kitty, East Sea Coast, Demerara.

35 Starch, from Buckyam, from Plantation Kitty, East Sea Coast, Demerara.

ANDERSON, GEORGE, & Co.

36 Vacuum-pan sugar, from Plantation Ogle, East Sea Coast, Demerara.

[This sugar was manufactured as follows:—The cane juice was clarified by lime, and the coagulum separated by subsidence, by means of clay. The evaporation was conducted in the ordinary way, and finished in the vacuum pan. This sugar was washed by means of Innis's process.]

JONES, JOHN.

37, 38 Vacuum-pan sugar, from Plantation Hope, East Sea Coast, Demerara.

[The sugar No. 37 was washed by means of Innis's process; that of No. 38 was cleaned by means of Hardman and Finzel's patent centrifugal machine.]

STUTCHBURY, J. S.

39 Vacuum-pan sugar, from Plantation Emnore, East Sea Coast, Demerara.

[In the manufacture of this sugar, the syrup was passed through animal charcoal before being put into the vacuum pan.]

LAING, JAMES.

40 Sugar, from Plantation Friends, River Berbice, manufactured in Gadsden and Evans's pan.

[This sugar on being removed from the pan was put into cones, and, after the molasses were drained off, was syruped.]

SHIER, DAVID.

41, 42, 43, 44 Muscovado and molasses, from the Colonial Laboratory, Georgetown, Demerara.

[This muscovado (No. 41) was made according to the plan recommended by Dr. Shier. Lime in slight excess was used in clarification. The coagulum was got rid of by subsidence. The excess of lime was neutralised, and the juice was concentrated on the open fire. No washing or syruping had recourse to. The specimen of molasses (No. 42) is from the muscovado sugar marked No. 41. The muscovado (No. 43) was made by a modification of Melsen's process. No washing or syruping was used. The specimen of molasses (No. 44) is from the muscovado sugar marked No. 43.]

STUTCHBURY, J. S.

45 Muscovado, from Plantation Fellowship, Mahaicong, East Sea Coast, Demerara.

[Manufactured by the ordinary process in use on estates in this colony.]

All of the above-mentioned sugars are the produce of the Otaheite or Tahiti cane (*Saccharum officinarum*, Lin.), the variety universally cultivated in this colony.]

46 Copaiba, balsam of, from River Pomeroon, Essequibo.

[There are several trees in this colony supposed to yield the balsam, not yet botanically determined.]

OUTRIDGE, J.

47 Caoutchouc, from River Demerara, near the Falls.

[Taken from the India-rubber tree by tapping, and formed into balls by the Indians, who climb the tree, and, as the gum exudes, rub it on their bodies till it assumes a sufficient consistency to be formed into balls.]

48 Milk from the cow-tree, from River Demerara.

[The cow-tree in question is the Hya-hya (*Tabernaemontana utilis*). It grows freely in the dense forests of this colony. It is related that an exploring party having felled one of these trees near a brook, the quantity of milk discharged by it was so great, as in the course of an hour to render the water quite milky.

It is one of the interesting discoveries of botanists that several trees yield a milk-like fluid, which is in almost all respects comparable to that afforded by the cow. Humboldt describes, in striking language, his slaking his thirst by a draught of milk from the *Palo de Vaca*, a cow-tree of South America. Trees belonging to different genera have been called by this name. The cow-tree of South America is an arto-carpad; other cow-trees belong to the order of figs. The milk has been analysed, and found to yield a considerable proportion of gelatine, a principle found in the animal fluid.—R. E.]

DUGGIN, T. B.

49 Gum resin, from the simiri or locust tree, from River Berbice.

[This gum is obtained by digging in the vicinity of the roots of the tree (*Hymenaea courbaril*, Lin.), from which it exudes in a vertical direction in columns or pieces upwards of a foot in length. It may also be obtained by tapping the tree, when in the course of a few days a large solid mass is formed. It is said to be the gum anime of commerce, and is occasionally used in this colony for the same purposes as gum copal. It may be obtained in great abundance in various parts of the colony.]

BONYUN, G. R.

50 Karman, from River Essequibo.

[Used by the Indians for waxing their nets and other purposes, and is said to be the inspissated juice of a tree called the man or mannee tree.]

OUTRIDGE, J.

51 Hyawai gum or incense, from River Demerara.

[This gum is very fragrant, and supposed to be suitable for pastilles and similar purposes. It is said to be obtained from the *Icica heptaphylla*, Aubl.]

STUTCHBURY, J. S.

52 Laurel oil, from River Pomeroon, Essequibo.

[This oil, supposed to be obtained from *Oreodaphne opifera*, Nees, is extensively used by the natives in affections of the joints. It is also an admirable solvent of India rubber.]

53 Crab oil, from River Essequibo.

[This oil is obtained from the seeds of the tree yielding crabwood, (*Xylocarpus carapa*, Spr., or *Carapa guianensis*, Aubl.) It is used in the colony for burning, and is highly esteemed as a hair oil.]

DUGGIN, T. B.

54 Dari tree, seeds of the, from River Berbice.

[Candles are made from these seeds, said to be equal to wax. The tree abounds throughout the colony.]

SHIER, D.

55 Sandbox tree, seeds of, from Plantation Kitty, East Sea Coast, Demerara.

[The seeds of *Hura crepitans*, Lin. They are a drastic purgative, and contain a very limpid oil.]

KOCK, H. A.

55a Fruit of the lana tree.

[This fruit is the produce of *Genipa Americana*, Lin., a tree very abundant in the colony, and produces the Lana dye.]

55b Lana dye, from the River Berbice.

[This dye is the juice of the fruit of the *Genipa Americana*, Lin. The colour produced is a beautiful bluish black. The Indians use it in staining their faces and persons, and the effect lasts for several days.]

OUTRIDGE, J.

55c Indian paint, from the River Demerara.

[This pigment is prepared by mixing arnotto, the red viscous pulp surrounding the seeds of the *Bixa orellana*, Lin., with crab oil, the produce of the seed of *Carapa guianensis*, Aubl. It is used by the Indians for decorating their persons, and other purposes.]

DUGGIN, T. B.

56 Mora tree, bark of, from River Berbice.

[The *Mora excelsa*, a fabaceous tree, was discovered by Sir R. Schomburgk. It is one of the most magnificent trees in the forests of British Guiana. The wood is stated to be equal to oak of the best kind.—R. E.]

57 Hog plum tree, bark of, from River Berbice.

[Bark of *Spondias lutea*, Lin.; used as a tanning substance, and very abundant.]

SHIER, DAVID.

58 Courida tree, bark of, from Plantation Kitty, East Sea Coast, Demerara.

[Bark of *Avicennia nitida*, Lin.; used as a tanning substance, and extremely abundant on the sea coast.]

STUTCHBURY, J. S.

59 Hy-yarri or Hai-ari, fish poison, from River Demerara.

[Stem of *Lonchocarpus nicou*, Dec.; used by the natives to intoxicate fish for the purpose of capturing them.]

[This fish poison has been described as being employed in the following manner:—The natives beat the root with heavy sticks till it is reduced to shreds like coarse hemp. They then infuse it, and throw the infusion over the area of the river or pool selected. In about twenty minutes every fish within its influence rises to the surface, and is either taken by the hand or shot with arrows. A solid cubic foot will, it is stated, poison an acre of water, and the fish are said to be still wholesome for human consumption.—R. E.]

KOCK, H. A.

59a Fruit of yarrisara, from River Berbice.

[This is stated by the contributor, Dr. Koch, to be the fruit of a vine, found in the interior of the colony, and which he claims the merit of having discovered to be the chief ingredient of the celebrated Wourali poison.]

STUTCHBURY, J. S.

60 Angostura bark, from River Pomeroon, Essequibo.

[Supposed to be obtained from *Galipea cusparia*, St. Hil. or *G. officinalis*, Hanc. Used as a febrifuge.]

61 *Rhizophora racemosa*, bark of, from East Sea Coast, Demerara.

[Bark of *Rhizophora racemosa*, Meyer; ascertained to be a very valuable remedy in cases of chylous urine.]

OUTRIDGE, J.

62 Trysals bark, from River Demerara.

[Used as an emetic by the Indians.]

STUTCHBURY, J. S.

63 Greenheart tree, bark of, from River Demerara.

[Bark of *Nectandra rodiei*, Benth. Yields the alkaloid known as bibirine, a febrifuge.]

DUGGIN, T. B.

64 Greenheart tree, seeds of, from River Berbice.

[Used as a tonic and febrifuge. Occasionally, in times of scarcity, these seeds are grated and mixed with decayed wallaba (the wood of *Eperua falcata*, Aubl.), and used by the Indians as food.]

[The greenheart tree of Demerara will probably become of considerable commercial interest and value. In Class 2 of the United Kingdom will be found notices of the alkaloid bebeerine, obtained from its bark, which promises to become a substitute for quinine. Its botanical name is *Nectandra rodiei*, and it belongs to the natural order *Lauracea*.—R. E.]

STUTCHBURY, J. S.

65 Guinea pepper, or grains of Paradise, from River Demerara.

[Seeds of *Amomum melegueta*, Roxb. These seeds are much superior to those imported from Africa.]

66 *Alpinia nutans*, seeds of, from River Demerara.

[These seeds (*Alpinia nutans*, Rose.) resemble, and in some respects possess, the properties of cardamoms.]

SHIER, DAVID.

67 Physic nuts, seeds of, from Georgetown, Demerara.

MANGET, Mrs.

68 Physic nuts, seeds of, from Georgetown, Demerara.

[These physic nuts are the produce of different trees, but are possessed of similar emetic and purgative properties, and are frequently used as a domestic medicine by the black population of the colony.]

ARRINDELL, Mrs.

69 *Quassia amara*, from Plantation Zeelandia, Wake-naam, River Essequibo.

[This is the produce of *Quassia amara*, Lin. It is distinct from the quassia of the shops, and is extensively and successfully used in the colony as a tonic and febrifuge. It is very abundant.]

STUTCHBURY, J. S.

70 Boeiri, bush rope, from River Demerara.

[This bush rope is plentiful in the interior of the colony, and is a favourite remedy of the Indians in pectoral complaints. It is exceedingly aromatic, and forms an excellent ingredient in stomachic bitters.]

BLAIR, DANIEL.

71 Cotton, cleaned, from Plantation Batavier, Mahaica River.

72 Cotton, uncleaned, from Plantation Batavier, Mahaica River.

[These specimens were obtained from wild or self-sown

plants, the remains of the cotton cultivation on Plantation Batavier, which was abandoned about twenty-five years ago.]

NETSCHER, A. D. VAN DER GON.

73 Cotton, uncleaned, from Plantation Klein Pouderoyen, River Demerara.

BEE, J. F.

74 Cotton, hard seed, cleaned, Plantation Woodlands, River Mahaica, Demerara.

HUGHES, P.

74a, 74b Mexican white seed. Large and small green seed; large and small kidney; loose black seed; all from Plantation Anna Regina, Essequibo.

BEE, J. F.

75 Cotton, loose seed, cleaned, Plantation Woodlands, River Mahaica, Demerara.

76 Cotton, loose seed, uncleaned, Plantation Woodlands, River Mahaica, Demerara.

[The above specimens of cotton are the produce of *Gossypium arboreum*, Lin., and other arboresecent species. Sir Robert Schomburgk, in his description of British Guiana, makes the following observations on the subject of the cultivation of cotton, p. 103:—"The indigenous cottons are very numerous, and the Indian has generally a few shrubs of that useful plant around his hut. However, I have seen the industrious Macusi cultivating it more extensively. The hammocks which the Indians manufacture of it are valued for their strength and durability, and are considered superior to the European article. Like the staples before enumerated, cotton has been only cultivated by the colonists at the coast regions; but its cultivation has in a great measure been abandoned, because our cottons, raised by free labour and in a British colony, were undersold by those produced by slavery in the United States. If, with regard to the abundance and cheapness of labour, British Guiana were put on the same footing as slave states in America, an inexhaustible supply of cotton of every description might be produced. There is no doubt that all kinds of cotton, from the best long staple down to the finest short staple, might be cultivated in the colony, as the kind which does not thrive on one soil or climate might be produced in another. An extent of sea-coast of 280 miles from the river Corentyne to the mouth of the Orinoko, would produce cotton vying with the best in the world. I doubt the opinion that the finest cotton will not grow at a greater distance than twenty miles from the sea. I have sent samples of the wild cotton from the interior to the colony which were admired by competent judges for their fine long staple and silky appearance. No care whatever had been bestowed upon the cultivation of these plants which grew at a distance of 300 or 400 miles from the coast. Although the growth of the plant was not luxuriant, it was covered abundantly with cotton of the most excellent quality; indeed it would be highly advisable to the cotton growers at the coast to exchange the seeds."]

ROSS, E. C.

76a Silk cotton, loose and in pod.

76b Silk cotton, bale of, from Georgetown, Demerara.

[Obtained from the seed vessels of the silk cotton tree (*Bombax Ceiba*, Lin.). It has been exported to the United States, and used in the manufacture of hats.]

DAVISON, W.

77 Plantain fibre, from Plantation Vigilance, East Sea Coast, Demerara.

NETSCHER, A. D. VAN DER GON.

78 Plantain fibre, from Plantation Klein, Pouderoyen, River Demerara.

[This fibre is produced from the stems of plantain and banana trees (*Musa paradisiaca* and *sapientum*), and might be obtained in very large quantities from the plantain cultivation of the colony. It is calculated that upwards of 600 lbs. weight of fibre might be produced annually from each acre of plantains, after reaping the fruit crops. At present the stems of the plantain trees, when cut down, are allowed to rot on the ground. If a remunerative price could be realized for this fibre, a new branch of industry would be opened up to the colonists.

*Note.*—In addition to the above-mentioned specimens, a barrel of the fibre, contributed by W. Davison, has been sent for experimental purposes. It may be proper to mention that in 1846, a gentleman visited this colony, and exhibited several specimens of cloth of a beautiful silky texture, and specimens of paper of superior quality, manufactured from the fibre of plantains grown in the Jardin des Plantes.]

DE BURTON, J.

79 Silk grass, fibre of, from Plantation Vigilance, East Sea Coast, Demerara.

[This fibre is obtained from *Agave vivipara*, Lin.]

DUGGIN, T. B.

80 Silk grass, fibre of, from River Berbice.

[This fibre is obtained from a species of *Bromelia*. It is very strong, and is used by the Indians to make bow-strings, nets, cordage, &c.]

81 Fibusiri, fibre of, from River Berbice.

[This fibre is derived from the Ita palm (*Mauritia flexuosa*, Lin.) It is used by the Indians for making hammocks, cordage, &c.]

BEE, J. F.

82 Mohoe, fibre of, from Demerara.

[Obtained from a tree of the mallow tribe (*Thespesia populnea*, *Correa*, or *Hibiscus elatus*, Swartz?) It is very strong, and used for making cordage, coffee bags, &c.]

83 Table top, including 84 different specimens of woods, the growth of the colony, viz. :—

- |                                   |                 |
|-----------------------------------|-----------------|
| 1 Sand Mora.                      | 28 Waiki.       |
| 2 Lana.                           | 29 Siridani.    |
| 3 Itikiribouraballi (young).      | 30 Hoobobballi. |
| 4 Kretti, or bastard silverballi. | 31 Bannia.      |
| 5 Kurara.                         | 32 Hyawaballi.  |
| 6 Kakaralli.                      | 33 Tatabo.      |
| 7 Brown silverballi.              | 34 Masaranuni.  |
| 8 Yellow silverballi.             | 35 Cabacalli.   |
| 9 Youraballi.                     | 36 Pritti.      |
| 10 Saouari.                       | 37 Canuballi.   |
| 11 Crabwood.                      | 38 Mora.        |
| 12 Yerara.                        | 39 Letterwood.  |
| 13 Purpleheart.                   | 40 Kucachara.   |
| 14 Simaruba.                      | 41 Wamara.      |
| 15 Gomarrow.                      | 42 Kamakasa.    |
| 16 Cedar white.                   | 43 Hiaballi.    |
| 17 Locust.                        | 44 Determa.     |
| 18 Coutaballi.                    | 45 Wadaduri.    |
| 19 Carahurri.                     | 46 Rosewood.    |
| 20 Huwassi.                       | 47 Saka.        |
| 21 Armiosi.                       | 48 Kerla.       |
| 22 Suradanni.                     | 49 Kamacusack.  |
| 23 Assepoca.                      | 50 Cedar, red.  |
| 24 Akaraki.                       | 51 Wild orange. |
| 25 Hymakusi.                      | 52 Guava.       |
| 26 Ducalaballi.                   | 53 Logwood.     |
| 27 Turiballi.                     | 54 Tabiccushie. |
|                                   | 55 Coffee.      |
|                                   | 56 Murwaana.    |

- |                     |                                  |
|---------------------|----------------------------------|
| 57 Kartaballi.      | 72 Greenheart.                   |
| 58 Washiba.         | 73 Hya-hya.                      |
| 59 Kimaasamasa.     | 74 Cabbage tree.                 |
| 60 Curbacalli.      | 75 Wallaba.                      |
| 61 Bartaballi.      | 76 Yarri yarri.                  |
| 62 Acourib root.    | 77 Waremia.                      |
| 63 Wara couri.      | 78 Hoobobballi.                  |
| 64 Ducalli.         | 79 Cannella, or wild spice wood. |
| 65 Arawica.         | 80 Itikiribouraballi, old.       |
| 66 Bangoe or ebony. | 81 Bully tree.                   |
| 67 Hackia.          | 82 Silberdani.                   |
| 68 Kurahara.        | 83 Brown silverballi, light.     |
| 69 Calabash.        | 84 Kofassa.                      |
| 70 Kuracurara.      |                                  |
| 71 Towraneroc.      |                                  |

[It will be seen from this table that British Guiana produces many woods highly ornamental and useful for cabinet-making and upholstery.]

OUTRIDGE, J.

84, 84a Mora, transverse and vertical sections, from River Demerara.

[The tree (*Mora excelsa*) producing this wood frequently reaches a height of upwards of 100 feet. It grows abundantly on barren sand reefs. It is tough, close and cross grained, and is peculiarly adapted for ships' timbers and planks, for which purpose it is extensively used. The trunk of this tree, when of the height of from 40 to 50 feet, will square from 18 to 20 inches, but when grown to that size it is generally faulty. The specimens sent are from a tree supposed to be from 30 to 40 years old.]

85 Greenheart, transverse section.

STUTCHBURY, J. S.

85a Greenheart, vertical section, from River Demerara.

[The greenheart tree (*Nectandra rodiei*) is very abundant, and its timbers, squaring from 18 to 24 inches, can be procured without a knot from 60 to 70 feet long. It is a fine-grained hard wood, well adapted for the planking of vessels, house frames, wharves, bridges, and other purposes, where great strength and durability are required. Mr. Manifold, engineer of the Demerara Railway, states that this is the best timber for resisting tensile and compressive strains, and is therefore well adapted for kelsons for ships and beams of all kinds.]

OUTRIDGE, J.

85b, 85c Specimens of black greenheart; transverse and vertical sections.

[The timber of this tree is used for ship-building, planks, &c., and is considered more durable than the common greenheart. The specimens sent are from a tree supposed to be about 50 years old.]

BUCHANAN, A.

86, 86a Purpleheart, transverse and vertical sections, from River Essequibo.

[The purpleheart (*Copaifera pubiflora* or *bracteata*?) yields a timber possessing great strength, durability, and elasticity, and is described by Lindley as "invaluable for resisting the shock of artillery discharges, on which account it is employed for mortar beds." It is used for windmill shafts, rollers, and machinery.]

[Like the greenheart, the purpleheart tree of Demerara belongs to the natural order *Fabaceæ*. It is found abundantly in the forests of Guiana. The timber is extremely valuable for certain purposes, as for the carriages of artillery, from its extraordinary toughness and capacity to resist violent concussion. The tree is the *Copaifera pubiflora* and *bracteata*. In addition to its timber it is

valuable for the quantity of balsam which gushes from its bark on being wounded.—R. E.]

## OUTRIDGE, J.

87, 87*a* Kakaralli, transverse and vertical sections, from River Demerara.

[This wood is very plentiful, and it has been proved that it is more durable than greenheart in salt water, as it possesses the quality of resisting the depredations of the sea-worm and barnacle. It may be had from 6 to 14 inches square. The specimens sent are from a tree supposed to be about twenty years old.]

88, 88*a* Wamara, or brown ebony, transverse and vertical sections, from River Demerara.

[This wood is hard and cross-grained, consequently not apt to split; it would, therefore, answer various purposes in naval architecture. It may be had from 6 to 12 inches square, and from 40 to 60 feet long. The Indians make war clubs of it. The specimens sent are from a tree supposed to be about twenty years old.]

89, 89*a* Woorballi, transverse and vertical sections, from River Demerara.

[This wood is very close and fine grained, is easily worked, takes a high polish, and is much used in the colony for furniture. It may be had from 15 to 20 inches square, 40 to 70 feet long. The specimens sent are from a tree supposed to be about twenty years old.]

## BUCHANAN, A.

90, 90*a* Wallaba, transverse and vertical sections, from River Essequibo.

[This wood is produced from *Eperua falcata*, Aubl., a tree very abundant throughout the colony. It is hard, splits freely, and is very durable from being impregnated with a resinous oil. It is used for house frames, palings, shingles, staves, &c. It has been ascertained that a roof well shingled with this wood will last upwards of forty years. It may be had from 15 to 20 inches square, from 30 to 40 feet long.]

## DUGGIN, T. B.

90*b* Wallaba, tecuba, or hart, River Berbice.

[This wood is the heart of the upper portion of the trunks of Wallaba trees which have been felled in the forests, and from which the sap wood has decayed. These are much used as paling posts and for other outdoor purposes, being found to be so durable as to be almost imperishable. They are about to be used as sleepers on the Demerara Railway, for which purpose it is supposed they will prove to be peculiarly well adapted. The defect of Wallaba and of its tacouba is its inability to bear great lateral strain. It therefore should not be used for beams longer than 12 feet.]

[Sir R. Schomburgk states in reference to this tree,—the Wallaba tree of Guiana,—that its wood is deep red, frequently variegated with whitish streaks, hard, heavy, shining, and impregnated with an oily resin which makes it very durable. Its botanical name is *Eperua falcata*.—R. E.]

## OUTRIDGE, J.

91, 91*a* Bully tree, transverse and vertical sections, from River Demerara.

[The tree yielding this wood is supposed to be a species of *Mimusops*. It is found throughout the colony, but most abundantly in the county of Berbice. It is of great size, and squares from 20 to 30 inches, and may be obtained from 20 to 30 feet long. The weather has little effect upon it, and it is employed for house frames, posts, floors, &c.

The upper portion of the trunk and branches are manufactured into shingles, wheel-spokes, palings, &c.]

92, 92*a* Silverballi, yellow, transverse and vertical sections, from River Demerara.

[This wood is supposed to be derived from a species of *Nectandra*. It is light and floats, and contains a bitter principle, which protects it from the attacks of worms. Hence it is much used for the outside planking of colony craft. It is also used for booms and masts. It grows to a great size, but then is often hollow. It will, however, square sound from 10 to 14 inches, from 40 to 50 feet long.]

## FAUSET, T.

93 Silverballi, portion of the planking of a drogher.

[This specimen formed part of the outside planking of a drogher employed in the conveyance of produce in this colony, and is known to have been exposed to the action of salt water during a period of 20 years.]

94 Silverballi, portion of the planking of a punt.

[This specimen formed part of the bottom of a punt known to have been used in the Demerara River for a period of 30 years and upwards.]

## BUCHANAN, A.

95, 95*a* Camara, or tonquin bean, transverse and vertical sections, from River Essequibo.

[This wood is obtained from *Dipteryx odorata*, the tree which produces the well-known Tonquin bean. It is hard, tough, and durable in an eminent degree; and it is said that a portion of its timber, one inch square, and of a given length, bears 100 lbs. more weight than any other timber in Guiana of the same dimensions. It is therefore peculiarly adapted for any purpose where resistance to great pressure is the object, and for shafts, mill-wheels, or cogs. It will square from 18 to 20 inches, from 40 to 50 feet long. This tree is, however, not very plentiful in this colony.]

96, 96*a* Saouari, transverse and vertical sections, from River Essequibo.

[This wood is obtained from *Caryocar tomentosum*, Dec. or *Pekea tuberculosa*, Aubl., the tree which yields the delicious nut known as the Saouari, or Sewarri nut. It greatly resembles in its properties the mora, being excellent for ship-building, mill-timbers, and plank, and may be had from 16 to 20 inches square, from 20 to 40 feet long.]

## OUTRIDGE, J.

97, 97*a*, 97*b* Yaruri, or paddlewood, transverse and vertical sections, from River Demerara.

[This wood is obtained from *Aspidosperma excelsum*, Benth. The whole tree, from 5 to 6 feet in diameter, and, to the first branches, about 50 feet in height, has the appearance of being fluted, or as if it consisted of a fasciculus of numerous slender trees. The fluted projections of the trunk are used by the Indians for the construction of their paddles. The wood is light, elastic, and very strong, and preferred to any other for cotton gin-rollers.]

98, 98*a* Hackia, lignum vitæ, transverse and vertical sections, from River Demerara.

[This wood, known in the colony as *Lignum vitæ*, is said to be obtained from *Guaicum officinale*, Lin.; but this seems doubtful, as the tree producing the wood attains a height of from 50 to 60 feet, and squares 16 to 18 inches, whilst the *Guaicum officinale* is described as a comparatively small tree about 4 or 5 inches in diameter. It is used for mill-cogs and shafts. The specimens sent are from a tree supposed to be about 40 years old.]

## DUGGIN, T. B.

99, 99a Lana, transverse and vertical sections, from River Berbice.

[This wood is obtained from *Genipa Americana*, Lin., the fruit of which yields the Indian pigment known as Lana dye. The tree is very high, and the trunk will frequently square from 14 to 18 inches. The wood is close grained, and is not liable to split.]

100, 100a Mammee apple, transverse and vertical sections, from River Berbice.

[This wood is obtained from the *Mammea Americana*, Linn., which produces the Mammee apple, or wild apricot of South America.]

[The Mammee apple tree is an ally of the celebrated Mangosteen tree. It is valued for the medicinal properties of its seeds. The flowers are distilled and produce a kind of alcoholic extract. The sap, when fermented, forms a sort of wine. It is sometimes called the wild apricot tree.—R. E.]

101, 101a Hyawa, transverse and vertical sections, from River Berbice.

[This wood is obtained from the *Icica heptaphylla*, Aubl., or incense tree, yielding the gum Hyawa.]

102, 102a Corkwood, transverse and vertical sections, from River Berbice.

## PONTIFEX, GEORGE.

102b Corkwood tree, abutment from near the root, from Troolie Island, River Essequibo.

[This wood is supposed to be obtained from *Pterocarpus Draco*, Linn., or *P. suberosus*, Pers., and is used chiefly as floats for fishing nets.]

## BEE, J. F.

103, 103a Courida, transverse and vertical sections, from Plantation Woodlands, River Mahaica.

[This wood is obtained from *Avicennia nitida*, Jac., a tree of surprising rapidity of growth. These specimens are from a tree five years old. The wood is perishable when exposed to the atmosphere, but is very durable under ground, and is therefore used as foundations for buildings.]

## OUTRIDGE, J.

104, 104a Itikiribouraballi, transverse and vertical sections.

[This wood is supposed to be obtained from *Machaerium Schomburgkii*, Benth. The trunk grows to the length of from 30 to 40 feet, and squares from 12 to 16 inches. It is used chiefly for cabinet work.]

105, 105a White cedar, or warracoori, transverse and vertical sections, from River Demerara.

## BEE, J. F.

105b, 105c White cedar, or warracoori, transverse and vertical sections, from River Mahaica, East Sea Coast, Demerara.

[This wood is obtained from *Icica altissima*, Aubl. It is light, easily worked, and very aromatic. Sir Robert Schomburgk states that one of his canoes, 42 feet long and 5½ feet wide, was made from a tree of this species. It is used for oars and paddles, and for boards for inside work of houses. During the American war it was used for staves of sugar hogsheds.]

## OUTRIDGE, J.

106, 106a Suradanni, transverse and vertical sections, from River Demerara.

[It is much used for timbers, rails, and covering boards for colony craft, and for naves and felloes of wheels. It

is also made into canoes by the Indians. It will square from 14 to 18 inches, from 30 to 40 feet long.]

107, 107a Determa, transverse and vertical sections, from River Demerara.

[This wood is used for masts, booms, and planking for colony craft; and as insects do not infest it, it is well adapted for chests, wardrobes, &c. It will square from 14 to 16 inches, from 40 to 60 feet in length.]

108, 108a Crabwood, transverse and vertical sections, from River Demerara.

[This wood is obtained from *Xylocarpus carapa*, Spreng., or *Carapa guianensis*, Aubl., the seeds of which yield the crab oil. It is a light wood, and takes a high polish, and is used for masts and spars, flooring, partitions, and doors of houses. There are two varieties, the red and white. These specimens are the white. It squares from 14 to 16 inches, from 40 to 60 feet long.]

109, 109a Koquerettaballi, transverse and vertical sections, from River Demerara.

[This wood forms excellent rafters and beams for cottages. It grows from 20 to 30 feet long, and from 4 to 6 inches in diameter.]

110, 110a Coutabally, transverse and vertical sections, from River Demerara.

[The tree which yields this timber grows upon sand-hills; the wood is very hard and durable if not exposed to the weather; it is plentiful, and principally used for house frames, and will square 12 inches, from 30 to 40 feet long.]

111, 111a Blackheart, transverse and vertical sections, from River Demerara.

[This is a good wood for house frames and for making furniture. It will square from 6 to 7 inches, from 20 to 30 feet long.]

112, 112a Cabacalli, transverse and vertical sections, from River Demerara.

[This wood is impregnated with a bitter principle, which defends it against worms; it lasts well under water, and is much used for planking colony craft. It must, however, be fastened with copper nails. It will square from 12 to 16 inches, or even more, from 40 to 45 feet long.]

113, 113a Yarri yarri, or lancewood, transverse and vertical sections, from River Demerara.

[This tree is stated by Schomburgk to be *Duguetia quitarensis*, Lindl., a slender tree found in tolerable abundance in the interior of the colony. The wood possesses much toughness and elasticity, and is used for gig shafts, and, when small, for whip handles and fishing rods. The Indians make their arrow points of it. It grows from 4 to 6 inches in diameter at the lower end, and from 15 to 20 feet long.]

[Sir R. Schomburgk states that the hard, tough, and elastic wood, so highly esteemed for the shafts of carriages and other coach-building purposes, is produced by this tree, yarri yarri. It belongs to the natural order *Anonaceae*, and its botanical title is *Duguetia quitarensis*.—R. E.]

114 Torchwood, from River Demerara.

[Supposed to be obtained from a species of *Amyris* or *Icica*. When beaten, so as to separate the fibre, the branches are used as torches by the Indians.]

115, 115a Tooroo, transverse and vertical sections, from River Demerara.

[This tree is a species of palm. It grows to the height of from 50 to 70 feet. Its woody outside is used by the

cabinet-makers for inlaid work, walking-sticks, billiard cues, &c.]

BEE, J. F.

116 Coffee tree, portion of the trunk, from Canal No. 2, River Demerara.

116a Coffee tree, vertical section, from Canal No. 2, River Demerara.

117, 117a Tigerwood, transverse and vertical sections, from River Demerara.

[This is the heart of the wood Itikiribouraballi, and is a valuable wood for cabinet-making.]

STUTCHBURY, J. S.

117b, 117c Transverse and vertical sections of letter wood, from the River Corentyne.

[This is obtained from *Brosimum Aubletii*, Poep, or *Piratinera guianensis*, Aubl., and is one of the costliest woods which Guiana possesses. It is of a beautiful brown colour with black spots, which have been compared to hieroglyphics; the spotted part being only peculiar to the heart, which is seldom more than 12 to 15 inches in circumference. It is adapted for cabinet work of small size and for veneering only. From its extreme hardness it is difficult to work, and therefore little used.]

OUTRIDGE, J.

117d, 117e Transverse and vertical sections of the saka or bastard purple heart-wood, from River Demerara.

[Used for furniture.]

117f, 117g Transverse and vertical sections of the itaballi tree, from River Demerara.

[The tree which produces this wood is *Vochysia guianensis*, Aubl., and is used by the Indians for making corials.]

117h, 117i Transverse and vertical sections of the wadaduri or monkey-pot tree, from River Demerara.

[The tree which produces this timber is the *Lechylthis grandiflora*, Aubl., and is plentiful. The wood is used for furniture, staves, &c. The specimens sent are from a tree supposed to be about 25 years old.]

117j, 117k Transverse and vertical sections of the hywaballi tree, from River Demerara.

[This tree is scarce. This wood, known as zebra wood, is used for furniture. The specimens sent are from a tree supposed to be about 30 years old.]

117l, 117m Transverse and vertical sections of the silbadani tree, from the River Demerara.

[This wood is used for furniture. The specimens sent are from a tree supposed to be about 20 years old.]

117n, 117o Transverse and vertical sections of the simiri, or locust tree, from River Demerara.

[The tree producing this wood is *Hymenonea courbaril*, Lin., and is plentiful in various parts of the colony. It often attains a height of from 60 to 80 feet, with a trunk from 7 to 8 feet in diameter. The wood is hard and compact, and its durability recommends it for mill rollers and similar purposes. The Indians make "woodskins" out of the bark. The specimens sent are from a tree supposed to be above 100 years old.]

117p, 117q Transverse and vertical sections of the towereroe or bastard bully tree, from River Demerara.

[It is very plentiful, and is used for framing timber, spokes, &c. It will square 25 inches, from 40 to 50 feet long. The specimens sent are from a tree supposed to be about 50 years old.]

117r, 117s Transverse and vertical sections of the Mariballi tree, from River Demerara.

[This tree is plentiful, and is used chiefly for spars. It

will square from 13 to 14 inches, from 30 to 40 feet in length. The specimens sent are from a tree supposed to be about 20 years old.

With regard to the timber trees of this colony, Sir Robert Schomburgk, in his description of British Guiana, published in 1840, p. 116, observes:—"I cannot conclude my observations on the capabilities of British Guiana, without referring once more to the importance of its timber trade, and the source of wealth which might be derived if there were a sufficient number of woodcutters. At present, if we make a few exceptions, it is only carried on by individuals who enter upon it with but little capital and slender means; and yet there are instances where the industrious and sober have reaped riches. The fitness of the timbers for naval architecture is unparalleled, and in some instances is said to surpass the teak. The greenheart, the mora, and souari or sewarri, of all other woods, are most unquestionably the best adapted for ship-building. Within the last ten or twelve years a considerable quantity of brown greenheart has been sent to Liverpool and Greenock; and I have been told that builders and others interested in shipping are now of opinion, after about ten years' trial of the wood, that in strength and durability it is superior to any oak, and it actually commands a higher price. Had these woods been introduced and extensively employed in the Royal Dockyards fifteen or twenty years ago, it is the opinion of competent judges that we should not now hear much of dry-rot and Kyan's patent; and not to mention that rapid decay of vessels built of English and African oak, and the consequent frequent repairs, with what saving to Government would it not have been connected! If, therefore, the attention of the Navy Board could be drawn to the important fact that British Guiana can furnish the finest and most durable wood in the world, in sufficient quantities to supply all the ship-building establishments in Great Britain, a double benefit would arise from it, namely, the saving to Government and the increased demand for the natural productions of the colony. The first experiment might be made to establish a dockyard for the repair of such of Her Majesty's cruisers on the West India station as draw not more than 18 or 19 feet water. The outlay of such an establishment would be trifling if the importance of ultimate success be considered. The woods which are qualified for ornamental purposes vie in elegance, if polished, with any in the world. The want of labourers is the great cause that these treasures lie comparatively hidden, and have scarcely excited attention. The demand in the colony has been so great for native woods, that those who are at present employed in that trade are not able to meet it." It may be proper to add to this statement from Sir Robert Schomburgk's work, the fact, that in consequence of British Guiana being so extensively intersected by navigable rivers, ships of considerable burthen may load in the immediate vicinity of most of the wood-cutting establishments.]

#### MISCELLANEOUS ARTICLES.

STUTCHBURY, J. S.

118 Tonquin bean, from River Demerara.

118a Tonquin bean, in capsules, from River Demerara.

[This bean is the fruit of *Dipterix odorata*, Willd., and is principally used to impart fragrance to snuff.]

DUGGIN, T. B.

119 Job's tears (bud-like seeds), from River Berbice.

[This very peculiar seed of a grass is the fruit of *Coix*



*lachryma*, Lin., and is used in Guiana for ornaments, such as necklaces, &c.]

[This singular term, Job's tears, is applied to the stony fruits of a graminaceous plant, *Coix lachryma*. They are valued on account of some supposed medicinal qualities. R. E.]

ROSS, GEORGE.

120 Soap berries, from Plantation Ruminveld, River Demarara.

[This is the kernel of the fruit of *Sapindus saponaria*, Lin., and is used for ornaments, necklaces, bracelets, &c.]

MANGET, Mrs.

121 Barricarrri seeds, from Georgetown, Demerara.

[These are the seeds of *Erythrina corallodendron*, Lin., and are used for ornamental purposes.]

SHIER, DAVID.

122 Buck, or canna shoots, or seeds of the "Tous les mois," from Georgetown, Demerara.

This is the seed of an undetermined species of *Canna*, variously supposed to be *C. coccinia*, *C. lutea*, *C. occidentalis*, and *C. Achiras*, and is used by the Indians for shot. From the rhizome of this plant is obtained the Tous les mois starch of commerce. It grows wild in this colony, and could be cultivated to any extent.]

MORISON & KNOX.

123 Isinglass, from Gilbagre, coast of Demerara.

[This is the sound of the *Silurus* —? a fish very abundant in the estuaries of the rivers of this colony.]

BEE, J. F.

124 Honey, from Plantation Woodlands, River Mahaica.

[This is the produce of a small wild bee, which is stingless, and easily domesticated. The honey is deposited in small separate pouches, and may be removed once every month by making a puncture in the bottom of the pouch, from which it readily flows, which opening, the insect afterwards speedily closes up.]

BARKLY, Mrs.

125 Ornamented hammock, made of silk grass, supposed to be the fibre of a species of *Bromelia*, or of *Agave vivipara*, Lin., ornamented with the feathers of the toucan, macaw, &c.

STUTCHBURY, J. S.

126 Ita, or eta palm hammock, made of the fibre of *Mauritia flexuosa*, Lin.

127 Ropes to the same, made from silk grass.

BARKLY, Mrs.

128 Hat, made of the bark of the ita palm.

129 Indian head dresses, ornamented with feathers, worn by the chiefs.

HOLMES, W. H.

130 Case of pagalas, or packalls, made of the outer rind of the ita palm, and much used in the colony as baskets.

131 Shaak-shaak, from River Demerara. A child's toy, and used by the Indians in their dances.

132 Fans, made of the ita palm.

SHIER, DAVID.

133 Matapi, or cassava squeezer, made of the ita palm.

[Used by the Indians for expressing the juice from grated cassava. Before being filled, it is compressed as far as possible so as to increase its diameter; it is then filled and suspended from a beam, and a lever is inserted into the lower loop, to the long end of which a weight is applied, by which the matapi becomes elongated. It will be observed that the change of form in the vessel will tend

to diminish its cubic contents, and when stretched to its utmost length, its capacity will be diminished by nearly one-third: hence its applicability for effecting expression.]

BEE, J. F.

134 Etami, or cassava-sifter, used by the Indians, made of the ita palm.

BARKLY, Mrs.

135 Model of an Indian house, and twenty-eight miniature models of furniture, implements, &c., as used by the natives.

ROSE, Miss.

136 Cotton hammock.

[This is made of the wild cotton from the interior of the colony, referred to in Sir R. Schomburgk's description of British Guiana as remarkable for its fine long staple, silky appearance, and excellent quality. Full-sized hammocks made of this material command a price from three to four times higher than those of English manufacture.]

RIES, BERNHARD.

137 Spun cotton, from River Pomeroon.

[This is also the wild cotton of the interior.]

STUTCHBURY, J. S.

138, 139 Fishing nets of silk grass, of Indian manufacture.

DENNIS, GEORGE.

140 Basket, used by the Indians when travelling, slung from their shoulders. Entire wardrobe of a female Indian of the Warrow tribe.

DUGGIN, T. B.

141 Indian war club, from River Berbice.

ARNOTT, ROBERT.

142, 143 Indian war clubs, from River Demerara.

144 Blowpipe and quiver, with poisoned arrows, used by the Indians.

[The inner tube of the blowpipe is a single internode of the *Arundinaria Schomburgkii*, Benth. These internodes are sometimes 16 feet in length. The arrow is inserted into the tube, having a dossil of cotton around its lower end, aim is taken, and the arrow projected by a sudden expiration. Accompanying the quiver, there is the maxilla of a fish which is used for partially cutting the poisoned end of the arrow, so that that portion may break off and remain in the wound. This cutting is effected by rapidly turning the arrow between the teeth of the maxilla.]

145, 145a Bows and arrows, bows made of washiba, used by the Indians.

DUGGIN, T. B.

146 Winna, used by the Indians for enclosing tobacco, in the form of sheroots, for smoking, and said to be made of the rind of the fruit of the Manicole palm, *Areca manicot*, Lodd., from River Berbice.

147, 147a Buck pot, used in preparing pepper pot.

[These pots are made by the Indians, of a peculiar description of clay found on the banks of the rivers in various parts of the colony.]

148 Indian fly-brush.

148a Walking-stick of letter-wood, carved by the Indians.

OUTRIDGE, J.

148b Adada, or wood-skin, from the River Demerara.

[This is the bark of the purple-heart tree, called by the Indians *Mariwayana*. Sir R. Schomburgk says:—"They take off the bark of this tree when fresh cut down, and with very little trouble convert it into a canoe, commonly called a 'wood-skin,' some of which are large enough to carry 20 to 25 persons with perfect safety on smooth

water." During the month of February of the present year, the contributor and two other persons, weighing together not less than 500 lbs., descended or "shot" the Rapids, about 100 miles above the estuary of the River Demerara, in this wood-skin, in perfect safety. The seats commonly made use of in wood-skins consist of two or more light cylindrical pieces of wood, the ends of which are notched and rest upon the gunwale. The wood-skin sent measures  $18\frac{1}{2}$  feet in length, and about 28 inches in width. Accompanying it are two paddles made of yaruri, or paddle-wood.]

149 Quack, or eovered basket, of negro manufacture, made of a palm called moucourou.

150 Basket, such as is used in coffee picking, of similar manufacture.

151 Hand basket, of negro manufacture.

152 Two baskets, of negro manufacture, made of the cabbage palm, *Areca montana*, Lodd.

153 Calabashes, the shell or rind of the fruit of *Crescentia cujete*, Linn.

STEELE, MATTHEW.

154, 154a Door-locks, made of greenheart, and in use among the ereoles of this colony.

155, 155a, 155b Door-locks, made of erabwood, and in use among the ereoles of this colony.

BEE, J. F.

156 Walking-sticks, made from the outer part or rind of the tooroo palm, from the River Demerara.

156a A box containing eighty small specimens of the woods of the colony.

157, 157a Diagrams showing the course of temperature at Georgetown, Demerara, during the five years 1846 to 1850, and the mean range thereof, &c.

158 Round table, composed of many kinds of wood, the growth of the colony.

HOPKINSON, JONATHAN, ESQ.

159 Japanned cup and plate, made from the fig-tree.

RIDGWAY, A. F., ESQ.

160, 161 Stuffed birds:—Toucan; blue parrot, from the Essequibo; yellow-bellied trojan. Skins of monkey, panther, &c.

COLLING, JOHN, ESQ.

162 Model of a Birch Indian's house and family.

RIDGWAY, A. F., ESQ.

163 Cotton grown by W. Finlaison, Esq., Fullerswood Park, Blacknow, Jamaica.

164 Specimens of the snake-nut of the colony.

[This remarkable vegetable production was discovered in Demerara by Sir R. Schomburgk. The embryo of the nut bears a strong resemblance, from its being spirally twisted, to a snake curled up. The tree producing this singular nut is one of the soap-nuts, and has been called by its discoverer *Ophdocaryon paradoxum*.—R. E.]

164a A native bag of coloured beads.

A necklace worn by the natives, which is composed of teeth of the wild boar (peccary?)

Another, of dried seed-vessels of a remarkable shield form, and very hard.

Another, of black polygonal beads, apparently of the wood of the Dari tree.

A throat ornament composed of black feathers, probably of the black toucan.

An "eatou," or Indian lady's wardrobe, being a sort of basket worked in beads, the pattern of which is a running square border of precisely that character which is commonly called "Egyptian," and of constant occurrence in Greek sculptures and paintings.

Pair of native sandals, the thongs as well as the soles of which are made of the bark of the palm tree.

Various war clubs and other weapons of hard and close-grained woods grown in the colony.

Bottle containing an aquatic fig-like plant, met with on the waters of the Guiana rivers. It is of a highly noxious nature, and by some supposed to be the plant yielding the Warouli poison.

A native ear-ring, composed of a long tooth, with a natural groove or furrow on its interior face, inserted on a piece of reed of very light texture.

A comb for the hair, made of the outer wood of the Tooroo palm.

Dried skin, 18 feet long, of a *Boa constrictor*.

[This skin exhibits numerous perforations by a sword, with which the boa was despatched, immediately after crushing to death and swallowing a negro boy, who had accompanied an English gentleman on a fishing excursion near the junction of the Essequibo river with one of its tributaries.]

A small case or quiver of hollow cane, suspended by a cord, spun from the wild cotton.

[The case contains an arrow point, or head, being a small thin splint of wood, little more than half an inch in circumference, and five or six inches long, hardened in the fire. The extremity has been steeped in the warouli poison. This arrow head is attached to the shaft by a thong or filament so contrived, that on striking an object it detaches itself, remaining in the wound, and thus enabling the native hunter to recover his weapon.]

Quayen, a native Indian squaw's dress.

Snake-nut, supposed to be the seed of a water-plant, which, when ripe, sinks, but, from some cause not germinating, again rises to the surface. Same species as horsechestnut. Grows on a vine near the rivers.

Wari, or warouli poison, made from a vine; the wood is chopped small, and boiled down to a paste.

## FALKLAND ISLANDS.

THE only contributions from these islands are the private collection of one exhibitor. This, however, represents, more or less completely, the natural features of the islands, since it includes sketches illustrative of their geology, botany, and mineralogy.—R. E.

1 WHITTINGTON, G. T., *Woking, Surrey*—Proprietor.

Portfolio containing fourteen sketches of remarkable places, geological formations, plants, &c., of these islands.

Portfolio containing twenty-seven sheets: specimens of grasses, sheep's wool, &c., produce of these islands.

Specimens of coal, copper, sandstone, quartz, spar, pebbles, rock, peat, lichens, orchilla weed, &c., from the same.



V.

BRITISH POSSESSIONS  
IN AUSTRALASIA.

EASTERN ARCHIPELAGO.—AUSTRALIA.  
VAN DIEMEN'S LAND.—NEW ZEALAND.

THE countries represented under this head, and above enumerated, have sent interesting collections of native produce of different kinds. Of these, the collection from Van Diemen's Land is the most extensive, comprising objects sent by a considerable number of exhibitors. In each instance, however, the attempt had been made to send for exhibition such articles as represented best the peculiar products of the country exhibiting. Many of the objects are of great importance to the merchant seeking a new source for known materials.—R. E.

EASTERN ARCHIPELAGO.

SOUTH AREA, S. 32.

THE Eastern Archipelago, so recently opened to civilization and secure commercial enterprise, is represented by three exhibitors, whose contributions consist of native cloth, a series of Malay paintings, a model of a pirate boat. In addition, is a great variety of natural products, vegetable and mineral. Among the former, gutta percha and its varieties will form an interesting study. The gums and spices are likewise valuable.—R. E.

1 GREY, The Countess.

Cloth manufactured by the Seribas, in Borneo.

Cloth made by the Mellanoes, in Borneo; sent home by Governor Sir James Brooke.

Twenty-nine drawings of Borneo plants.

2 HAMMOND, W. P. & Co., Merchants, London.

Specimens of sugar; coffee; sago, pearl; sago, common; sago, flour; pepper, black; pepper, white; nutmegs; mace; cloves; gambier; cutch; gum gamboge; gum benjamin; gum lac; rice; tortoise-shell; turtle-shell; M. O. P. shells; elephants' teeth; elephants' grinder; gutta percha; gum caoutchouc, or India-rubber; gum damma, and isinglass. The latter manufactured in the Archipelago from the interior membranes of fish, and valued on account of its highly glutinous character.

A series of thirty-six paintings, by a Malay artist.

A model, made to scale, of a sailing-boat used by the natives in the China Seas and Eastern Archipelago for the purposes of smuggling and piracy.

Specimens of rattans, bamboos, &c., grown in and imported from the Eastern Archipelago.

3 WOOLLEY, W., Secretary to the Eastern Archipelago Company, 34 Cornhill.

Bark cloth, manufactured by the Dyaks of Borneo.

Specimens of hard wood from Borneo; and surface coal from Labuan.

NEW SOUTH WALES.

SOUTH AREA, S. 30.

ABOUT twenty exhibitors from this colony have sent articles for exhibition. The character of these productions accords with the peculiar and commercial importance of the colony itself, consisting as they do principally of raw materials and produce, wool being the most prominent article. Australia may be rightly considered the most extensive wool-producing country in the world. In 1833, the imports from that country into Britain amounted to about three and a-half million pounds; in six years they had risen to ten million pounds, and in thirteen years to upwards of twenty-four million pounds. The climate combines the qualities essential to a wool-growing district, being dry, with a warm summer and a cold winter. On the Camden estate the late Mr. Macarthur succeeded in rearing those Merino flocks, the germ of which he had, in 1806, introduced into Australia by means of sheep imported in a vessel named by him the "Argo." They have proved one of the chief sources of the prosperity of the Australian wool trade, now grown into national importance, and in the past year amounting to thirty-six million pounds, valued at two millions sterling. On the same estate, of which four coloured views are exhibited, an interesting experiment is now being made of introducing the cultivation of the vine. The vineyards are situated on the Nepean River, forty miles south-west of Sydney. The following account of these experiments, which, if having, as there appears every probability of, a successful issue, cannot fail to become of great commercial importance:—

"After many experiments, local experience was at length obtained. The best varieties of vines having been selected, were transferred to a proper site in 1830, after the soil had been deeply trenched for their reception. This vineyard comprises about twenty-two acres, and is situated on a natural terrace, originally of alluvial deposit, a formation which is of frequent occurrence on the banks of several of the larger streams in New

South Wales. The soil is a porous, brown, fine-grained siliceous loam, of great depth, containing much decomposed vegetable matter, proxide of iron, and probably a considerable quantity of potash. In sinking a well an opportunity was offered of ascertaining the condition of the soil to the depth of fifty feet. Little change was observable for the first twenty feet; but the presence of vegetable matter became gradually less apparent, and the iron more abundant: the soil, however, continued to be quite as porous as at the surface. In descending further the change was more rapid, becoming more ferruginous, with a considerable admixture of alumina, until, at the depth of forty feet, it appeared to be little but sand, clay, and iron, of a bright red colour, and in such combination as to be perfectly permeable to water, and consequently to the roots of the vines. At the depth of forty to fifty feet water is obtained freely by infiltration, apparently from the bed of the river Nepean, which flows at about that level, in a deep channel several hundred yards distance. During periods of heavy rain this stream swells so much as to overflow its banks in certain places, and then forms rapid currents between the chain of alluvial terraces, such as the one described, and the higher grounds behind, rising to within a few feet of the surface of the former, and forming them into a series of temporary islands, some of them of great extent.

"The soil of these terraces possesses in great perfection many of the requisites for vine cultivation in a hot climate, which is also extremely uncertain with respect to moisture. During the most rainy periods it is never too wet; nor after being duly trenched does it, during the longest droughts, even close to the surface, ever become thoroughly deprived of moisture.

"The great depth and porous character of the soil renders it permeable to the surface water, however abundant, and capable of transmitting it back again by capillary attraction to the surface as it becomes parched by the great heats of summer. In less than twenty years, roots of the vines were found to have penetrated fifteen to twenty feet—how much deeper is not known. The growth of the plants is luxuriant, more equal, one year taken with another, than on the hill soils—their crops abundant and certain, were it not for the liability of damage from hailstones, from frosts late in the spring, and rottenness in the fruit when a series of showery weather happens towards the end of summer; the last two accidents being of more frequent occurrence in low than elevated situations.

"About ten years subsequently to the formation of the last-mentioned vineyard, another was commenced in a totally different site and soil; it occupies part of the slope of a hill of moderate elevation, the surface of which has been formed into terraces, to prevent damage from washing during heavy rains. The soil is a calcareous loam, resting at about two to four feet upon shale, passing into soft calcareous clayey sandstone, the soil itself being full of fragments of decomposing rock and of indurated marl or calcareous earth. Although very expensive to form into vineyards in a suitable manner, this description of land promises to be productive and to yield wine of very good quality. A similar description of land exists in considerable quantities throughout the older portion of the colony."

No wines being permitted for exhibition, the specimens sent over are not found in this collection. Australia possesses every requisite in regard of her natural capabilities for producing wine and dried fruits, not inferior to Spain itself. But experience is as yet wanting. The increasing importance of the tallow and leather trades is indicated by articles of that class exhibited. An interesting apparatus for determining the power of propellers is exhibited among these objects.—R. E.

1 ARMITAGE BROTHERS, *Huddersfield*—Importers and Manufacturers.

A bale of scoured Sydney skin-wool, grown in New South Wales, and washed by Armitage and Company of Sydney.

1A BIDWELL, J. G., Government Commissioner of Lands, *Zinana, Wide Bay, Australia*.

A log of wood from the interior of Wide Bay district, north-east coast of Australia, the *Briggalo* of the squatters (Bricklow of Leichardt's Journey), a species of *Acacia*, probably undescribed.

2 DAY, T. & W., *Sydney*—Manufacturers.

Specimens of colonial timber. Pair of ash oars and pair of paddles, manufactured of colonial wood.

2A BRIEARS, JAMES, *Sydney*.

Two beef hams spiced and cured by the exhibitor.

[The articles sent by the two preceding exhibitors were forwarded through Mr. A. Bogue.]

3 BURCHETT, J. R., 15 *Edmonton Crescent, Edmonton*.

A desk and a chess-board of polished woods.

4 CALLAGHAN, —, Crown Prosecutor, Attorney-General.

Two volumes of statutes, printed from types made in Sydney, and the books bound in Sydney.

5 CLINCH, J., 31 *Abchurch Lane*—Importer.

A set of bagpipes, made by George Sherrer, Sydney.

6 DUNBAR, D., *Limehouse*.

Samples of wheat flour from Port Phillip, New South Wales. Agent, N. Tweeddale.

7 DANGAR, R. C., *Billiter Street*.

Preserved fresh beef and mutton, a substitute for salt meats, from Newcastle, near Sydney.

8 LEARMOUTH, THOMAS, 40 *Royal Crescent, Notting Hill*—Importer.

Merino wool from Port Phillip.

9 MOTLEY, THOMAS, *Leeds*—Proprietor.

Wool, from Sydney, New South Wales.

10 DEVITT & MOORE, 9 *Billiter Street*.

A coach wrench, made at Sydney.

11 DUDGEON & Co., 1 *New Bank Buildings*.

Ores and specimens of wood from Sydney. Cured hams. Various samples of cotton grown near Maitland.

12 LEARMOUTH, THOMAS, 40 *Royal Crescent, Notting Hill*.

Four samples of Australian sheep's wool from New South Wales.

13 MACARTHUR, Lieut.-Colonel E.

Case containing 132 specimens of Merino wool, derived from the late Mr. Macarthur's original flock. In 1807 the first importation into England of this wool was 245 lbs. In the year 1848, it was 23,000,000 lbs. from New South Wales alone (valued at more than 1,200,000*l.*); and from the whole of the Australian colonies 36,000,000 lbs.

Four views in New South Wales, one being Camden (46 miles S. W. of Sydney), the original seat of Australian sheep husbandry, and now becoming celebrated for its vineyards.

[Specimens of the wines produced at these vineyards have been sent over to England; one of these is a hogs-head from the first vineyard, made from a grape imported

from France called "La Folle," mixed to the extent of about one-third with another sort from Madeira, called the "Verdeilho," the former being very productive and the latter remarkable for its richness in the saccharine principle. In the process of manufacture the grapes were crushed by being passed through a machine of simple construction, which reduces them thoroughly without bruising the stalks, and which, with the application afterwards of moderate pressure to the "rape," separates the juice from it with ease and expedition.

The wine was fermented in large vats of hewn stone containing from 800 to 1,600 gallons, in which it remained until the tumultuous fermentation had subsided. It was then drawn off into large store casks, containing 400 gallons, and suffered to continue the gentle stage of fermentation until quite still. The casks were regularly filled up, at short intervals, as the fermenting liquid subsided. When the process was sufficiently complete it was clarified with isinglass.

Another is a quarter cask, from the "White Muscat of Lunelle." The grapes were suffered to acquire a very advanced stage of maturity, to the extent of shrivelling on the bunches. To this wine, during the tumultuous fermentation, was added at different times very pure brandy of home manufacture, previously filtered through charcoal to render it quite flavourless, in the proportion of two pints of pure alcohol to the hundred pints of wine.

These wines have a certain dryness and bitterness peculiar to the wines of New South Wales, to which the palate becomes accustomed: but with age this bitterness passes off. The specimens sent are said to be void of this taste.

The wines at Camden are rarely fit for use until three years old, and greatly improved by keeping. They are very wholesome, and are extensively used by persons who have acquired a taste for them.]

15 MOSES, SON, & DAVIS, 14 & 15 *Aldgate High Street.*

Cask of Australian mutton tallow, and another of beef tallow, from the boiling establishment of Messrs. Benjamin and Moses, Sydney.

16 WATSON, YOUNG, & Co., 2 *Abchurch Lane, City.*

Orchilla maroon roans; red roans. Enamelled hides, enamelled kangaroo skins, patent kangaroo skins, prepared by Thomas Hall and Co.

17 BLAND, Dr., *Sydney.*

Model of the exhibitor's invention for extinguishing fire arising from spontaneous combustion in ships laden with wool.

18 SHELDON, FRANCIS W., *Civil Engineer.*

1. Model of lattice bridge for colonial railways or works, formed chiefly of unsawn timber, and of original detailed construction.

2. Model of plate rail for colonial railways, with original arrangement of details; formed of five-eighths inch iron plate, laid on iron bark hardwood.

3. Model of trestle frame for colonial railways, used instead of embankments where timber is plentiful.

N.B.—The above were designed by the exhibitor for the Sydney Railway Company.

4. Specimens of hardwood, in common use in New South Wales, and suitable for the above purposes.

19 THE AUSTRALIAN AGRICULTURAL COMPANY,  
12 *King's Arms Yard, Moorgate Street.*

Specimens of coals from the Company's mines at Newcastle, New South Wales.

20 LEON, LOUIS, 65 *Hatton Garden.*

A block of spermaceti, manufactured in New South Wales from the sperm whale of the South Seas.

21 MITCHELL, Lieut.-Col. Sir T. L., Surveyor-General of New South Wales.

1. A close cylinder of water for testing the power and action of propellers, is mounted on wheels, which move in grooves cut in a board, to which are attached bearings which support the piston-rod, passing through a stuffing box; and on which piston the model propeller is attached by a socket, and fixed by a nut inside.

The model propeller is placed within the cylinder by unscrewing the cap from the collar, to which is fitted a leathern washer; so that when screwed close, the whole is water-tight. The cylinder is to be fitted with a funnel, at the receiver, after the whole apparatus has been adjusted.

The turning gear is to be applied by inserting the shaft at the connecting socket. Multiplying wheels drive this propeller, which, acting on the water, causes the whole cylinder to move backward or forward, with more or less speed, thereby proving the power of the propeller on the water.

2. The Bomaring propeller used with the small steam engine in Port Jackson. Others of larger construction have been sent to England for trial, and may be heard of at Messrs. D. Cooper and Co., 3 Cophthall Chambers, City.

3. Rope made from the *Doryanthes excelsa*, with specimens of the leaf and of the fibre.

This root (a bulb) grows in great abundance, covering some wild lands near Sydney. The leaves sent are from the Botanic Gardens; those from which the ropes were made were 6 feet long. The rope absorbs tar, which it is said the New Zealand flax will not.

4. Cone of the *Bidwellii araucaria*, "Bunya bunya," the native name. The fruit inside is eaten by the natives near Moreton Bay, in which direction the tree is found, growing in circumference 70 or 80 feet, and to a proportionate height.

5. New map of New South Wales (not yet published). Original three-sheet map of the colony, engraved and printed at Sydney. The engraver is deaf and dumb, and was taught map-engraving in the colony by the compiler of these maps.

6. School-book, written, printed, and published at Sydney.

7. Specimens of native copper and of galena, both from Canobolas Mountains, New South Wales.

22 RAYNER, A. & G., *Sydney.*

Two specimens of doeskin cloth, 20 yards of each.

23 WEBSTER, Captain, *Governor of Darlinghurst Gaol.*

Hats made from the leaf of the cabbage-tree, manufactured by the prisoners in Darlinghurst gaol, exemplifying the industry and discipline of the prisoners in the Australian gaols.

24 GIBBS, Colonel, *Sydney.*

Neats'-foot oil.

MORRISON, Mrs., *Sydney.*

Stockings and mits knitted from a thread made of the opossum fur, by the exhibitor.

[The articles sent by the four preceding exhibitors were forwarded through Mr. A. Bogue.]

SOUTH AUSTRALIA.

SOUTH AREA, R. 21.

AUSTRALIA, regard being had to the vast size of the country, and the value which attaches to its products, is only inadequately represented in the Exhibition. The specimens presented are, however, of a very interesting and valuable description. The copper ores, which have been so productive of commercial prosperity to the individuals concerned in their extraction, are shown by an interesting selection from the Lyndoch Valley mines, near Adelaide, and the Burra Burra mines. The extraordinary results of the latter undertaking are among the occasional marvels of mining speculation. Specimens of the carbonate and oxide of copper and of native copper are exhibited. In addition, attention requires to be drawn to a recent attempt to introduce the cultivation of the silkworm into this colony, and specimens are exhibited. Some agricultural and geological specimens likewise deserve notice.—R. E.

1 SOUTH AUSTRALIAN COMPANY, 4 *New Broad Street*.

Specimens of copper ores from Kanmantoo mines :—  
Black and yellow sulphurets. Green and blue carbonate. Red and grey oxide. Native copper. Peacock, Pyrites, &c.

2 The BAROSSA RANGE MINING COMPANY, by Messrs. COODE, BROWNE, & Co., 10 *King's Arms Yard, Moorgate Street*.

Stones of copper ore, as raised from the lodes. Sulphuret of copper, containing 40 per cent. of pure copper, raised in the Lyndoch Valley, about thirty miles from Adelaide, South Australia.

3 GRAHAM & HALLETT, *South Australia*—Proprietors.

The following articles are from the mines at Burra Burra :—

- 1 Red oxide of copper.
- 2 Green carbonate of copper.
- 3 Green carbonate of copper.
- 4 Red oxide and carbonate combined.
- 5 Red oxide and blue carbonate.
- 6 Strata in which the minerals occur.
- 7 Native copper.
- 8 Malachite and red oxide of copper.
- 9 Fibrous malachite.
- 10 Cabinet specimens, arranged.
- 11 Views of Burra Burra mine and smelting-house, and the township.

[The Burra Burra mines present one of the most striking examples of successful mining speculation with which we are acquainted. From indications which were regarded as of a most favourable character, the mine was started on the 5th of September, 1845, with a capital of 12,320*l.*, subscribed by a few merchants and traders at Adelaide. The following returns of ore raised from the commencement of the undertaking to September, 1850, will exhibit the extraordinary success of this undertaking :—

|                            | Tons.  | Cwts. |
|----------------------------|--------|-------|
| September 30, 1846 . . . . | 6,359  | 10    |
| „ 1847 . . . .             | 10,794 | 17    |
| „ 1848 . . . .             | 12,791 | 11    |
| „ 1849 . . . .             | 7,789  | 16    |
| „ 1850 . . . .             | 18,692 | 9     |

Making a total in 5 years of . 56,428 3

of copper ore, varying in quality from ore containing 30 per cent. of copper to much that produces 70 per cent. of that metal. The money value of this is 738,108*l.*

This great mineral deposit exhibits some peculiarities.

Although the miners and the proprietors speak of working on lodes, these are of a very different character from the copper lodes of the primary rocks of this country. In a great basin, formed in an amphitheatre of hills, an immense deposit of clay—the result of the decomposition of the clay-slate—has taken place; this, under conditions which we are not enabled to determine, became also the reservoir for the reception of copper. In all probability it was first deposited in the pure metallic state—a fine example of the electrotype process of Nature. During this process, the so-called veins spread themselves through the soft clay in various directions, in precisely the same manner as we may, by carrying the terminal wires of a voltaic battery into a mass of clay saturated with sulphate of copper, form a curious arborescent mass. By the action of the oxygen contained in the water, this copper becomes oxidized by the slow process which gives rise to the very beautiful crystals of red oxide of copper, and from this state it passes into the blue and green carbonates, under the action of carbonic acid, the difference in the colour of the two arising from the quantity of water in combination.

The malachites, which are now very extensively employed for ornamental purposes, are carbonates of copper, and large quantities of the specimens selected from the Burra Burra mines are sold for this purpose.

Nearly all the copper ore raised at the South Australian mines, has been hitherto sent to England, and smelted at Swansea; but there has been recently a smelting establishment introduced, which promises to be of great advantage to the colony.

The number of people now employed at the Burra Burra mines is 1,003.—R. II.]

4 MOSES, H. E. & M., 87 *Tower Hill*.

Fine sample of Australian wheat, weighing 64 lbs. per bushel; the produce of Adelaide, South Australia. Preserved fresh meats, prepared at the Camperdown establishments, Sydney, New South Wales. They are upwards of three years old, have undergone a voyage of 16,000 miles, are in a perfectly fresh state, and will keep so for any number of years.

5 HALLETT, R. & SONS, *Broad Street, Ratcliff, London*—Importer.

Articles from South Australia :—

- 1, 2 Wheat.
- 3 Hard soap.
- 4 Olive oil.
- 5 Five cases, containing specimens of opal and other rocks allied to precious stones.
- 6 Two samples of flour, and one of barley.
- 7 A dried bouquet of small native plants.
- 8 Specimens of stream gold, and gold in its matrix.
- 9 A case of polished stones, the produce of the colony.

6 MURRAY, Mrs.

Specimen of silk raised by the exhibitor, at Adelaide, in 1850, the produce of 580 worms fed on white and black mulberry leaves.

7 GREY, Earl (forwarded by).

Specimens of silk produced in South Australia, and showing the capabilities of that country for the production of this article.

9 HEATH & BURROW, 6 *New London Street, Mark Lane*, and *Old Corn Exchange*—Importers.  
Specimens of South Australian grain.

10 JOSEPH, J. A., 7 *Blomfield Crescent, Bayswater*.

A block of copper ore, weighing about 800 pounds, and containing about 45 per cent. of copper, raised from

Baker's lode, at Tangkillo Reedy Creek, South Australia, on the special survey of the Australian Mining Company.

Varieties of copper ores raised from the Company's various lodes of ores; minerals, and geological specimens from South Australia, to illustrate the surveyed portion of that colony.

Miscellaneous specimens of minerals.

[The South Australian mines have a peculiar interest from their geological and mineralogical character. The ores of copper are usually of the richest varieties, the peroxide carbonates, green and blue. The South Australian Mining Company possess a territory of 22,000 acres; their principal mining operations are the Tangkillo, where seven lodes are now being explored. Baker's lode has already produced nearly 4,000 tons of copper ore, giving from 12 to 30 per cent. of pure copper. Formerly all the ore was sent to this country to be smelted; but smelting operations are now carried on in South Australia, and the result is very satisfactory to the colony.—R. H.]

## VAN DIEMEN'S LAND.

SOUTH AREA, S. 31.

The general character of the productions of the Tasmanian colony resembles that of the others, and is principally remarkable for the number and interesting nature of the products contained in the first four Classes of the Exhibition. The exceptions are, however, more numerous than in some other instances. Some interesting and attractive articles of furniture, formed out of richly-marked woods, are presented to notice, and may prove instrumental in directing the attention of decorative furniture makers to the capabilities of the materials for the construction of furniture in England. A few specimens of textile manufactures are also shown, such as a roll of tweed, made of colonial materials. A considerable number of specimens of fur, and of the preparation of leather, harness, &c., indicate that progress in this important manufacture has been made by the colonists. The possession of an abundant supply of tanning materials of the purest kind, added to the abundance and cheapness of live stock, cannot fail to render this an increasingly important direction for industrial activity.

What will, however, receive most attention, and what is also most abundantly exhibited by this colony, is a collection of specimens of woods applicable for every purpose of art or use. The musk-wood of this colony, as an instance, is mentioned as valuable for ornamental purposes, of a close and fine grain, and variously veined and dotted. The wood of the myrtle is represented as of a beautiful vein and watered, fitting it admirably for showy picture-frames. The blue gum-tree promises to become a most valuable substitute for oak in ship-building. It reaches a vast height in the forests of this colony; two sections are exhibited which were taken at a distance of 134 feet apart, and a very trifling difference in their diameter appears. The Huron pine is likewise a valuable timber, and specimens of it are exhibited as applied to domestic and ornamental purposes. In addition to these it is suggested as affording an excellent material for organ-pipes, which might be bored out of the solid timber, and some pipes are exhibited. The advantages claimed for them are, that they yield a softer and more mellow tone than pipes made of a looser grain. This wood is also extremely durable, and little influenced by atmospheric vicissitudes.

Vegetable products of various kinds are also exhibited. The agriculture of the colony is represented

by various specimens of wheat, barley, flour, &c. The gum resins of those wonderful liliaceous trees of Tasmania, the grass-trees, is exhibited, and suggested as a material for the dyer and varnish-maker. Interest will also be much excited by the specimens of what is called the native bread of Tasmania. This is in reality a large underground truffle, known botanically as *Mylitta Australis*. One of the specimens weighed originally upwards of fourteen pounds. It is eagerly sought by the natives, and not less so by the marsupial animals, who devour it with great greediness. It is half-roasted before being used for human food.

The furs of those animals which communicate so peculiar a feature to the zoology of Australia generally, the *Marsupialia*, have been supplied in a manufactured and unmanufactured state. The feathers and oil of the sooty petrel, with articles of industrial value, are exhibited. Honey and wax are likewise sent; and it is indicated that the feeding of the industrious insects producing them can nowhere be more successfully conducted than in this colony. To the naturalist a specimen of silicized wood, found about thirty-two miles from Hobart Town embedded in lava, will appear of much interest.—R. E.

DENISON, His Excellency Sir W. T.

1 Blue gum timber of Van Diemen's Land (*Eucalyptus globulus*). Squared log 20 ft. long, 12 ins. by 12 ins. Said to be equal to oak as a ship-building timber. The two sections exhibited were taken from one tree at a distance of 134 ft. apart.

2 Stringy bark of Van Diemen's Land (*Eucalyptus robusta*). Squared log 20 ft. long, 12 ins. by 12 ins.

[This tree forms for the most part a large tree; the timber is, however, coarser than the last, and is chiefly used for house building and fencing.]

3 Blackwood, or lightwood, of Tasmania (*Acacia melanoxylon*). Squared log, 20 ft. long, 12 ins. by 12 ins. A very hard close-grained dark and full-veined cabinet wood, used for furniture and fittings.

4 Sassafras of Tasmania, often sassafras (*Atherosperma moschatum*). Squared log, 13 ft. long, 12 ins. by 12 ins.

[This tree yields a soft, even, and close-grained timber, adapted for turning, and, probably, for the earver. It is largely used for flooring-boards, the inside work of houses, and cabin fittings in ships.]

5 Myrtle of Tasmania (*Fagus Cunninghamii*). Squared log, 12 ft. long, 12 ins. by 12 ins. It is hard and close grained, with a lively red tint, streaked and mottled near the root; and takes a fine polish.

These timbers are abundant in the colony, and can mostly be obtained of any required size.

ADCOCK, Mrs. W., *Elizabeth Street, Hobart Town.*

6 Two canisters of preserved meat.

HAMILTON, —, *Elizabeth Street, Hobart Town*—  
Manufacturer.

7 Hall-chair of blackwood (*Acacia melanoxylon*), with a raised shield cut on the back, kangaroo and emu for supporters, surmounted by a rose, with thistle on one side and shamrock on the other, carved in relief and polished.

8 Small round table, of Huron pine (*Dacrydium Franklinii*) with chess-board in the centre, and the pedestal of the same. The chequers are alternately of plain Huron pine, and wood of the she-oak of Tasmania (*Casuarina quadrivalvis*), with a border of blackwood, surrounded by a narrow string of myrtle, the whole being enclosed with a band of figured pine.

PIERSON, —, Cabinet-maker.

9 Pier table or chiffonnière, of polished blackwood. Exhibited to show the dark tints and veining of this wood, and the polish of which it is susceptible.

FRASER, A., Coachmaker, *Collins Street, Hobart Town*—Manufacturer.

10 A pair of carriage wheels. The naves of the wheels are of blackwood, the spokes and felloes of blue gum; for these purposes, the two kinds of timber have been found well adapted.

REEVES, J. G., *Elizabeth and Macquarie Streets, Hobart Town.*

11 Case of leather, viz. :—  
Hides of black and brown harness leather. Kip. Kip waxed on the grain, and black-grained kip.  
Kangaroo-skins, grained, brown, and waxed.  
Calf-skins, waxed and brown.  
Black bazils.  
Pair racks, cordovan horse hide.  
Sole leather.

[These skins and hides are of Tasmanian production, and have been tanned and dressed at the establishment of the exhibitor.]

CHAMPION, —, *Hobart Town.*

12 Table of muskwood, *Eurybia argophylla* of Tasmania. Round turnover table, with brasswork and springs of Tasmanian manufacture. Exhibited for the beauty of the wood.

DOUGLAS RIVER COAL COMPANY.

13 Coal, two bushels.

[This coal is exhibited as a sample of the strong bituminous coal occurring on the east coast of Van Diemen's Land, and traceable over a large area of country, in seams varying in thickness from a few inches to ten feet and upwards.]

BROWN, JOHN, Cabinetmaker, *Launceston.*

14 Sideboard of blackwood of Tasmania.

[The timber of the *Acacia melanoxylon* is considered to be more deeply veined and tinted on the northern than on the southern side of the colony. It is called blackwood in Launceston and lightwood in Hobart Town.]

15 Top of star loo table. Composed of alternate-pointed sections of figured Huron pine and blackwood, veneered on cedar, and meeting in the centre; with finished pedestal.

16 Lady's table of muskwood.

STRAHAN, R., *Bonnington.*

17 Box of salt: two sorts—coarse, for pickling; and table, or basket salt. A sample from which the magnesian salts are said to be thoroughly separated.

MURRAY, W., *Liverpool Street, Hobart Town.*

18 Box of starch: the box made of Huron pine, figured. There are now several starch manufactories in Hobart Town.

DIXON, JAMES, *Skelton Castle, Isis.*

19 Flax, dressed in 1850 by the exhibitor, who is endeavouring to establish the cultivation of flax in Tasmania.

20 Box of dried apples.

[Generally, more fruits are dried in the northern than the southern side of Van Diemen's Land; but the last two summers have been unfavourable, from the unusually low temperature.]

BUTTON, THOMAS, *Launceston.*

21 Samples of glue.

22 Concentrated solution of Mimosa bark, extracted by cold water.

[This solution is employed for tanning leather; it is considered in a great measure free from colouring matter, and from the principles which give a dark, uneven character to leather, rendering it brittle, and depreciating its value in the English market.]

23 Mimosa bark, ground. Bark of *Acacia molissima*, or black wattle, said to be the best for tanning.

DENISON, His Excellency Sir WILLIAM THOMAS, *Norfolk Island.*

24 Box of tobacco in leaf.

25 Box of arrow-root.

26 Box of maize.

27 Cayenne pepper.

28—35. Wheats: — Farmer's friend, white velvet, James's Essex, Golden drop, white Kent, mother of plenty, velvet, and white Lammas.

MARSHALL, G., *Noble Farm, Pittwater.*

36 Wheat, bag marked G.

37 Oats, bag marked G.

DENISON, His Excellency Sir W. T.

38 Wheat (Chidham).

MILLIGAN, JOSEPH, *Oyster Cove.*

39 Sassafras bark of Tasmania (*Atherosperma moschatum*). Used medicinally as a bitter and a stomachic.

MURRAY, W., *Liverpool Street, Hobart Town.*

40 Mould candles.

M'NAUGHTEN, A.

41 Cask of velvet wheat.

LIPSCOMBE, F.

42 Cask of white Lammas wheat.

M'NAUGHTEN, A.

43 Cask of white wheat.

WALKER, JOHN, *Barrack Street, Hobart Town.*

44 Cask of white wheat. Cask made of silver wattle, with hoops of young wattle.

BROWN & Co., *New Wharf.*

45 White wheat, in a cask of Huron pine, hooped with black wattle (*Acacia mollissima*).

46 White wheat, in a cask made of black wood, with hoops of black wattle.

TOOTH, E., *Bagdad.*

47 Cask of malt.

PATTERSON, —, *Liverpool Street, Hobart Town.*

48 Cask of small malt. Cask made of silver wattle, wattle hoops.

WALKER, J., *Barrack Street, Hobart Town.*

49 Pearl barley. Cask made of silver wattle, with wattle hoops.

CLAYTON, H., *Norfolk Plains.*

50 Flour. Cask made of silver wattle, with wattle hoops.

WALKER, J., *Barrack Street, Hobart Town.*

51 Fine flour. Cask made of silver wattle, with hoops of young black wattle.

M'NAUGHTEN, —.

52 Superfine flour of Van Diemen's Land.

MILLIGAN, A. M., *Launceston.*

53 Small cask of biseuit, manufactured of Tasmanian flour.

BROCK, —, *Macquarie Street, Hobart Town.*

54 Common seamen's biseuits.

55 Ship biseuits, fine.

DENISON, His Excellency Sir W. T.

56—65 Muskwood (*Eurybia argophylla*), smoothed and polished on one side to show the grain.

[The muskwood of Tasmania is valuable for the purposes of the cabinet-maker, being variously veined, dotted, and marked upon a brown-ground colour. It is close and fine in the grain, takes a high polish, and harmonises well with the gilding on picture-frames, into which it is often worked up. The musk-tree grows only in dense forests and damp situations; and though it does not attain the size of a forest tree in Van Diemen's Land, it yet yields slabs large enough for ordinary ornamental work. The finest fancy wood is of course obtained from parts near the root, and from knotty gnarled butts of trees.]



66 Slab of myrtle (*Fagus Cunninghamii*), of Van Diemen's Land.

[This myrtle often composes dense forests of many miles, and individual trees in such situations, attain a girth of from 30 to 40 feet, with a proportionate height. The wood is of a fresh pink colour when newly cut, and is often very beautifully veined and watered, which fits it for showy picture-frames, and similar cabinet-work.]

67—70 Cedar (*Athrotaxis selaginoides*), or pencil pine, of Tasmania, Marlborough, and Lake Country.

[The pencil pine found in the ravines and gorges of the mountain, and the high table-land of the colony, in groups, or singly; sometimes in the forests, and not unfrequently in bare, unsightly groves; of dead, dry, and bleached stems, with a few large limbs attached, at the height of from 3,000 to 4,000 feet above the level of the sea.]

71, 72 Sections, with bark.

73 Celery-topped pine (*Phyllocladus asplenifolia*) of Tasmania.

[This pine attains a height of 150 feet, and grows in all the cold and moist parts of Van Diemen's Land, in a handsome pyramidal form. The young trees are sometimes used as spars for rigging vessels, but they are too heavy; the timber is very white and close-grained, and useful for household purposes.]

74, 75, and 76. Section, with bark, 20 inches long, 12 inches in diameter. The same,  $\frac{1}{4}$  foot, and 12 inches in diameter. Rosewood, or zebra wood, of Tasmania, said to be plentiful about Marlborough and Lake Country.

77 Muskwood log, from Tasman's Peninsula.

SMITH, C. T.

78 Hops, Tasmanian.

MILLIGAN, J., *Mount Wellington, and Constitution Hill.*

79 Hones for edged tools.

DENISON, His Excellency Sir W. T.

80 A drip-stone, from Norfolk Island. Filters made of this rock, which appears to be a raised beach of calcareous grit, are in general use in the colony, and much approved.

MILLIGAN, J., *Flinders' Island, in Bass's Straits.*

81 Gum: gum resin of the grass tree (*Xanthorrhæa australis*).

[This gum resin, or balsam, is highly inflammable, yielding, on combustion, a clear white flame and rich fragrant odour, and is said to be used in churches in place of frankincense; it dyes calico a nankin colour; enters into the composition of some sealing-wax, and may become the basis of a varnish. Very abundant on many of the meagre soils of clay and sand in Flinders' Island and the neighbouring islands and continent.]

FOWLER, —, *Maria Island.*

82—85 Dogwood slabs (*Bedfordia*).

86, 87 Muskwood slabs (*Eurybia argophylla*).

88 He-oak.

89 Ironwood, or *Lignum vitæ* of Tasmania. (*Notelæa ligustrina*.)

ROBINSON, —, *Westbury.*

90 A gun-stock of blackwood. Roughly cut into form, and polished on one side to show the grain of the wood.

WHITESIDES, —, *Hobart Town.*

91 Blackwood of Tasmania. A thin piece, polished on one side.

92 Myrtlewood.

93 Muskwood.

QUINN, —, *Argyll Street, Hobart Town.*

94 Blue gum of Van Diemen's Land (*Eucalyptus globulus*). A piece taken near the root, squared and polished on two sides, to show the grain.

QUINN, —, *Norfolk Island.*

95 Maple. Small piece of veneer, polished.

M'NAUGHTEN, —, *Hobart Town.*

96—102 Muskwood of Van Diemen's Land (*Eurybia argophylla*).

HADDEN, Capt. R. E.

103, 104 Muskwood of Van Diemen's Land.

EUSTON & MILLIGAN, *Macquarie Harbour.*

105, 106 Ironwood, or *Lignum vitæ* of Tasmania. Cross section of the trunk of the tree.

[This tree rarely attains a diameter of more than 12 or 14 inches. The density and hardness of this wood is such as to have led to its application in making sheaves for ships' blocks.]

BROWNRIFF, —.

107, 108 Muskwood slabs.

BURGESS, Mrs., *Davey Street, Hobart Town.*

109 Worsted work, representing a branch from a blue gum tree in flower, with four birds of Tasmania perched on the twigs. The branch, leaves, and flowers of the blue gum (*Eucalyptus globulus*) are represented. The birds are a red-breast, a small honey-sucker, a pardalote, and the blue-headed wren. The frames of this and the next are of the timber of the myrtle-tree of Van Diemen's Land, made by Mr. Pearson, of Hobart Town.

110 Worsted work, representing a group of indigenous flowers of Tasmania. In the centre is the warratah (*Telepea truncata*); immediately over it is a head of the grass-tree of Mount Wellington in flower (*Richea distichophylla*); then in order come *Acacia verticillata*, *Billardiera longiflora*, *Acacia armata* (an exotic) *Richea sp.*, *Acacia mollissima*, *Acacia verniciflua*, *Casuarina quadrivalvis*, *Pomaderris*, *Boronia variabilis*, *Tetralthea sp.*, *Pultenea sp.*, and *Solanum laciniatum*.

HOOD, R. V., *Liverpool Street, Hobart Town.*

111 Timber of silver wattle (*Acacia dealbata*), with one side polished.

112, 113 Muskwood slabs.

114, 115 Blackwood slabs, squared (*Acacia melanoxylon*).

116 Cross section of small tree of Huron pine, with one corner smoothed and polished.

117 Huron pine slab (*Dacrydium Franklinii*), squared, and polished on two sides.

118 Muskwood slab, (*Eurybia argophylla*), squared and polished, to show the grain and character of the wood for ornamental purposes.

119 Myrtle slab (*Fagus Cunninghamii*), from the root.

120 Myrtle slab, from the stem of the tree.

DENISON, His Excellency Sir W. T.

121 Rosewood, *Acacia sp.*, of Van Diemen's Land. Found in the Lake Country near Marlborough.

122, 123 Rosewood of Van Diemen's Land.

124 Celery pine slab (*Phyllocladus asplenifolia*), squared.

125 Rosewood.

HOOD, R. V.

126 Huron pine picture frame, with gilt moulding; the gold leaf made by Mr. Hood.

127 Muskwood picture frame.

MARRIOTT, The Venerable Archdeacon.

128 Muskwood picture frame.

HOOD, R. V. *Hobart Town.*

129 Myrtlewood picture frame.

WISEMAN, —, *Hobart Town.*

130 Whip, for tandem or four horses. Thong of colonial leather, and the stick a young sassafras of Tasmania.

131 Two ladies' riding whips, of whalebone, tipped with silver, by Mr. Jones.

132 Whip for stock-hunting. Thong of colonial leather, and stick of she-oak.

133 Stock-hunter's saddle, complete. Manufactured of colonial cow-hide, prepared in Hobart Town.

134 Stock-hunter's breastplate.

BUTTON, THOS., *Launceston*.

135 Dressed kangaroo skins.

DENISON, His Excellency Sir W. T.

136 Roll of Tweed. Colonial material, manufactured by the inmates of Cascades' establishment.

137 Hank of yarn.

SUPERINTENDENT OF QUEEN'S ORPHAN SCHOOLS.

138 Woollen gloves, knitted. Manufactured by the children in the Queen's Orphan Schools.

139 Woollen socks, knitted.

140 The same, unbleached.

141 Woollen stockings, knitted.

142 Shawls, knitted.

BARNARD, J.

143 Swansdown, two skins.

CLEBURNE, R., *Murray Street, Hobart Town*.

144 Samples of soap.

LUMSDEN, —, *Brisbane Street, Hobart Town*.

145 Loo-table top, of Huron pine.

146 Pedestal for the table.

WATCHORN, W., *Liverpool Street, Hobart Town*.

147 Cask of tallow. The exhibitor claims to have been the first to export tallow to England from the colony.

DENISON, His Excellency Sir W. T.

149 Loo-table top, dogwood (*Bedfordia* sp.).

[The dog-wood, or *Bedfordia* tree, is one of the most beautiful fancy woods of Van Diemen's Land. It attains to a larger size on Maria Island than elsewhere. In the vicinity of Hobart Town it is a mere shrub.]

150 Pedestal for the same.

151 Top of a sofa-table, inlaid with chess-board in the middle.

ROUT, W.

152 Portmanteau. Made of colonial leather.

GUNN, W., *Launceston*.

153 Feathers of mutton-birds, or sooty petrel (*Puffinus brevicaudis*).

[These feathers are much used for pillows, bolsters, and mattresses, and, when properly prepared, answer the purpose well. Owing to the numbers of this bird which resort to the islands in Bass's Straits, and the profusion of feathers with which it is clothed, this article can be obtained in abundance.]

ROUT, W., *Elizabeth Street, Hobart Town*.

154 A small rope line.

155 Small lines, three sizes.

156 Best small rope, three sizes.

157 Cable-laid lines, three sizes.

158 Common lines, two sizes.

MARSHALL, —, *Hobart Town*.

159 Riding-whip, common. Made entirely of colonial materials.

160 Two whip-thongs—one for gig, and one for hunting-whip. Made of horse-hide, dressed in Hobart Town.

OAKDEN, PHILIP, *Launceston*.

161 Wool, two fleeces, Leicester improved.

[The produce of sheep imported from the best flocks in England in 1837, is exhibited to show the improvement in the softness and silky appearance of the fleece, which are attributed to the nature of the climate.]

HART, —, *Hobart Town*.

162 Glue.

163 Oil, from neats' feet.

164 Oil, from sheep's trotters.

HOOD, R. V.

165 Gold leaf. Manufactured from Californian gold, brought to Tasmania by colonial trading vessels.

166 Gold-beaters' skin.

McKENZIE, Mrs., *Blue Hills, Bothwell*.

167 Knitted gloves, made from opossum fur.

SLIEGLITZ, Mrs., *Killymoon, Break-o'-day*.

168 Gloves, made from opossum fur.

TOOTH, E.

169 Gloves, made from opossum fur.

McKENZIE, Mrs., *Bothwell*.

170 Lady's cape of opossum fur.

TOOTH, E.

171 Gloves, made from lambs' wool.

BUTTON, THOS., *Launceston*.

172 Parchment.

ROUT, W.

173 Brushes, one set of four.

LIPSCOMBE, F.

174 Flax, dressed.

SHARLAND, W.

175 Carriage-rug. Made of skins of the black opossum, lined with skins of the native cat.

DENISON, His Excellency Sir W. T.

176 Rugs of various furs. Made of skins of the brush-kangaroo (*Halmaturus Bennetii*), forest kangaroo (*Macropus major*), black opossum (*Phalangista fuliginosa*), native cat (*Dasyurus viverrinus*), tiger-cat (*D. maculatus*), well preserved, exhibited as specimens of great rarity and beauty.

SHARLAND, Mrs., *George Town*.

177 Book of pressed algae, collected by the exhibitor.

DAVIES, Ven. Archdeacon.

178 Rug of skins of black opossum (*Phalangista fuliginosa*).

179 Rug of tanned skins of brush-kangaroo.

MILLIGAN, J.

180 Carpenter's bench-screw.

181 Three pairs of shoe-lasts.

VALENTINE, Dr., *Campbelltown*.

182 Three organ-pipes of Huron pine, bored in the solid piece, with stops, &c.

[Two of these are bored in solid pine, and are found to yield a softer and more mellow tone than those made of woods not so hard in the grain. It is considered that the tube, being free from joints and glue, and made of very durable wood, when properly seasoned, will be little influenced by atmospheric changes. The small pipe has a stopper, which being removed, an octave above will be produced. The stopped pipe is regarded as a novelty; it gives a very soft note, well adapted for the treble half of the stop-diapason of a chamber-organ. The third is exhibited to show how an open pipe of the usual construction may be tuned by means of a stopper, without injury to its size.]

WARD, C., *Collins Street, Hobart Town*.

183 Stockman's ankle-boots, of colonial material.

REGAN, —, *Liverpool Street, Hobart Town*.

184 Nine dressed kangaroo skins, tanned with wattle bark.

HARPER, —, *Launceston*.

185 Prepared groats.

WARD, C.

186 Blacking for shoes.

ROUT, W.

187 Tanned skin with the hair on of the *Thylacinus cyanocephalus*. The hyæna, or tiger of the colonists, which has become very scarce.

[The Thylacine or "pouched hyæna" of the Tasmanian colonists is the largest and most formidable of the carnivorous species of that peculiar order of quadrupeds (*Marsupialia*), which are almost exclusively confined to Australia and Van Diemen's Land. The Thylacine is peculiar to Van Diemen's Land, and, as its ravages amongst the flocks of the settlers are as destructive as those of the wolf in other countries, it is hunted down with great perseverance, and will probably be the first of existing quadrupeds which will be extirpated.—R. O.]

DENISON, His Excellency Sir W. T.

188 Six tanned skins of the *Ornithorhynchus paradoxus*. The platypus of the colonists. The fine fur under the coat of long hairs upon its back is said to be equal to the fur of beaver for hat-making.

[The *Ornithorhynchus* is peculiar to Australia and Tasmania, and combines with the hair and fur of a mammalian quadruped, the webbed feet and the beak of the duck, whilst the male has spurs on the hind legs like a cock. In its internal anatomy the *Ornithorhynchus* offers many marks of resemblance to both birds and reptiles, and forms the nearest link in the mammalian series to the oviparous classes.—R. O.]

SMITH, M. C. T.

189 Sample of fine wool.

DUNN, —, *Davey Street*.

190 *Mylytta Australis*, a native bread obtained on the Snug Estate, North West Bay, D'Entrecasteaux Channel.

[The native bread of Tasmania, which grows under ground, like the truffle in England, and, like it, has a peculiar smell. It is edible, having formed, in a half-roasted state, a portion of the diet of the aborigines, and has been successfully tried in soup and in puddings by Europeans. This specimen is unusually large, having weighed 14 $\frac{1}{16}$  lbs. in 1846, at present it weighs 10 $\frac{1}{16}$  lbs.]

LOWES, T. Y.

191 *Mylytta Australis*, obtained at Glenorchy 17 years ago.

M'NAUGHTEN, —.

192 Writing-desk, of muskwood, inlaid with pine, blackwood, she-oak, and myrtle.

193 Dressing-case, or work-box, of the same materials.

MILLIGAN, J., *Argyll Street, Hobart Town*.

194 Necklaces of shells, as worn by the aborigines of Tasmania.

[The shell composing these necklaces seems to be closely allied to the *Phasianella*. It is very abundant in the various bays and sinuosities of the island. It possesses a naereous brilliant lustre, which is disclosed by the removal of the cuticle, and this the aborigines effect by soaking in vinegar, and using friction. Various tints, black, blue, and green, are afterwards given by boiling with tea, charcoal, &c.]

WALKER, ABM., *Norfolk Plains*.

195 Plumbago (black lead).

[This specimen was found in a seam or vein about 5 inches thick, traversing schistose clay, overlying an old quartzose and crystalline limestone, in a shaft where lodes of lead and copper are expected to be realised.]

ROLWEGAN, —, *Collins Street, Hobart Town*.

196 Book, in one volume, printed and published in Van Diemen's Land, bound in colonial calf, gilt and lettered with gold leaf manufactured in Hobart Town from Californian gold.

MILLIGAN, J., *Argyll Street, Hobart Town*.

197 "Tasmanian Journal," three volumes, printed and published in Van Diemen's Land.

ANDERSON, —, *Liverpool Street, Hobart Town*.

198 Set of ladies' tortoiseshell combs.

BROWN, FIELDING, —, *Hobart Town*.

199 Candlestick, turned, of ironwood, from Norfolk Island (*Olea apetala*). The tops are turned from the root of the Norfolk Island pine (*Araucaria excelsa*).

MILLIGAN, J., *Argyll Street, Hobart Town*.

200 Snuff-box, turned of ironwood (*Olea apetala*).

201 Snuff-box, of muskwood of Tasmania (*Eurebia argophyllum*).

202 Snuff-box, of Huron pine.

203 Globular snuff-box, turned out of the tooth of the sperm whale.

204 Ladies' thread-holder, turned.

205 Ladies' puff-box, turned.

206 Goblet, turned.

MOSES, S. *Liverpool Street, Hobart Town*.

207 Jaw of a sperm whale, with forty-eight teeth, complete.

[The sperm whale *Physeter macrocephalus*. This species differs from the great whalebone whales, in having a row of large teeth in the lower jaw, and a few small ones concealed in the gum of the upper jaw; the spermaceti is contained in a large cavity on the outside of the skull above the cranium.—R. O.]

HULL, HUGH.

208 Half section of the trunk of the Tolosa tree (or *Pittosporum bicolor*). This is the wood of which the aborigines chiefly made their waddies or clubs.

M'NAUGHTEN, —.

209 Muskwood slab.

FREEMAN, REV. E., *Brown's River*.

210, 211 Veneer, of the oak of Tasmania (*Casuarina quadrivalvis*).

212 Piece of a knot of myrtle-tree of Tasmania.

213 Veneer of he-oak of Tasmania (*Casuarina stricta*).

214 Two veneers, of native cherry-tree of Tasmania (*Exocarpos cupressiformis*).

215, 216 Veneers of Tasmania honeysuckle tree (*Banksia Australis*).

DENISON, His Excellency Sir W. T.

220, 221 Half sections of a limb of honeysuckle.

222, 223 Half sections of a small she-oak tree.

MILLIGAN, J.

221 Section of a small stem of *Richea pandanifolia*, obtained at Macquarie Harbour. Specimen, sliced, bevelled, and French-polished, to show the pith, medullary rays, and beautiful markings of the wood.

[This plant grows like a palm, and attains the height of thirty to forty feet and ten inches diameter; it is confined to the dense wet forests on the western side of the island.]

SMITH, PHILIP, *Ross Reserve*.

222 Small bale of wool.

MILLIGAN, J.

223 Specimen of pinkwood (*Carpodontos lucida*) obtained at Macquarie Harbour.

[This tree attains an elevation varying from 100 to 150 feet in height, with a good clear barrel, and grows chiefly on the western side of the island in dense myrtle forests. The timber, which is fine-grained and very hard, has been used for making sheaves for ships' blocks.]

PECK, GEORGE.

224, 225, 226 Cribbage boards, veneered on pine, inlaid, &c.

MILLIGAN, J.

227 Butter-print of Huron pine (*Microcarys tetragona*).

MOSES, CHAMPION, &amp; Co.

228 Eight ivory teeth of the sperm whale.

DENISON, His Excellency Sir W. T.

229 Maple of Norfolk Island, a square specimen.

MILLIGAN, J.

230 Seven baskets, made by the aborigines of Tasmania.

231 Model of a water-pitcher, made by the aborigines of Van Diemen's Land.

[This water-pitcher is made of the broad-leaved kelp, and is large enough to hold a quart or two of water. The only other vessel possessed by the aborigines for carrying a supply of water was a sea-shell, a large cymba, occasionally cast upon the northern shore of Van Diemen's Land, which contained about a quart.]

STRUTT, WILLIAM, *Bath Street*.

232 Marble, from Maria Island, partially dressed.

BOYD, J.

233 Marble, from Maria Island, cut and dressed as paper weights.

TIBBS, —, *Goulbourn Street, Hobart Town*.

234 Specimens of crockery-ware, made from the clay found in the domain.

KERMODE, R. Q., *Mona Vale*.

235 Small bale of wool—exhibited as a fine sample.

JENNINGS, J. D., *Liverpool Street*.236 Churn, made of Huron pine (*Microcarys tetragona*).

MOSES, S.

237 Bundle of whalebone; an important article of export.

SMITH, Lieutenant, R.N.

238 Raspberry and currant jam.

239 Green gooseberry jam.

240 Red gooseberry jam. 241 Quince jam.

ROAT, W.

242 Bundle of curled horse-hair.

SYMONDS, E.

243 Corn riddle, coarse.

244 Barley riddle, coarse. 245 Corn sieve, fine.

246 Fire-screen, for chair-back; made of willow, grown, dressed, and dyed in Van Diemen's Land.

247 Bottle basket, flat. 248 Bundle of willow rods.

249 Fishing basket.

250 Three double-handled baskets.

251 Book basket. 252 Knife basket.

253 Child's basket, round.

MILLIGAN, J.

254 Gum of Acacia (*Mucranata*); a shrubby tree on Flinders' Island, Bass's Straits.

255 Guano, from Babel Island.

256 Specimen of grey granite, from Flinders' Island.

257 Granite, from the east coast of Van Diemen's Land.

258 Granite, from the Hampshire Hills.

259 Porphyritic granite, from Webb's Harbour.

260 Limestone, from Fingal and Break-o'-day.

261, 262 Limestone, with galena, from Norfolk Plains.

263 Brown-clay iron ore, found near Fingal.

264 Clay iron-stone. Found in beds, alternating with bituminous coal, near the Douglas River, on the east coast of Van Diemen's Land.

265 Reddle—red ochre or red chalk. It occurs in masses of uniform and determinate shape, imbedded in alluvium of loam and earth.

266 Ore of iron, from the Hampshire Hills. It is nearly pure iron; seems crystalline; and is highly magnetic,

with polarity. It occurs in masses, at the line of contact between granite and basalt.

267 Ore of iron.

[This ore is found in nodules with quartz, in granite soil, near the Housetop Mountain, north-west of Van Diemen's Land; formerly used by the aborigines as a paint, being first peroxidized by roasting, and then reduced to a fine powder by grinding between two stones.]

268 Ore of manganese, from the vicinity of the Frenchman's-cap Mountain.

DENISON, His Excellency Sir W. T., *Tasman's Peninsula*.

269 Two cross sections of the barrel of the blue gum tree.

270 Limestone, from Maria Island.

FLEGG, R. C.

271 Wellington boots, of kangaroo skin, dressed in Hobart Town.

DENISON, His Excellency Sir W. T.

272 Specimen of calcareous grit, from Norfolk Island.

MILLIGAN, J.

273 Cake of bees'-wax, of Tasmania.

SYMONDS, E.

274 Key basket.

275 Round basket, open. 276 Long basket.

277 Straw hat, from Norfolk Island.

278 Hoop for a sieve, made of Huron pine.

MILLIGAN, J.

279 Four models of canoes of the aborigines of Van Diemen's Land.

[These are exact models of the large catamarans, in which the natives used to cross to Brunce Island: the material is bark of the *Melaleuca squarrosa*.]

COX, F.

280 Case of Tasmanian insects.

BONNEY, —.

281 Case of Tasmanian birds.

GUNN, W., & MILLIGAN, A. M., *Launceston*.282 Oil of the mutton-bird, or sooty-petrel (*Puffinus brevicaudis*).

[This is an oil of a deep-red colour, and is obtained by pressure from the stomach of the young bird. It is said to possess virtue as a liniment in rheumatism, and it burns with a clear bright light. The sooty-petrel frequents certain low sandy islands in Bass's Straits, in vast numbers during the summer, burrowing to lay its solitary egg, and literally undermining the ground.]

BROWN &amp; Co.

283 Oil of the southern black whale.

284 Oil of the sperm whale. 285 Oil of the black fish.

LOWES, T. Y.

286 Oil of the shark.

DENISON, His Excellency Sir W. T.

287 Blood juice, obtained from a tree in Norfolk Island, which makes an indelible marking-ink, and is said to be used as a dye for calicoes, &amp;c.

MILLIGAN, J., &amp; HULL, H.

288 Gum kino, from the blue gum-tree, the stringy bark, and other *Eucalypti*.

[This kino is said to be equal, as a medicinal agent, to the kino from the East Indies, and is yielded very profusely by the *Eucalypti*, after infection or injury.]

BONNEY, —.

289 Manna.

[This specimen is an exudation from the leaves and delicate succulent twigs of the white gum-trees (*Eucalyptus*

*mannifera*) of Van Diemen's Land, after their perforation by an insect in the summer. It soon exsiccates, and falls in the form of irregular tears; and during December, January, February, and March is usually very abundant. Its properties are similar to, but less powerful than those of the manna of the druggist.]

ABBOTT, JOHN.

290 Iron-sand, a fine emery-like substance, which occurs in thin layers on the sea-shore at Long Bay in D'Entrecasteaux Channel, being a deposit from water passing through iron-stone beds, percolating the soil, and depositing the metallic matter where it comes in contact with the salt water.

ROUT, W.

291 Honey of Tasmania. Two bottles, one of 1849, and one of 1850.

MILLIGAN, J.

292 Resin of Oyster Bay pine (*Callitris Australis*).

[This is a very white resin, found sometimes, but rarely, in tears of a bright amber tint, and scarce. The Oyster Bay pine is only found along a narrow strip of country near the sea, on the east coast of Van Diemen's Land, and islands adjacent.]

ROUT, W.

293 Bees' Wax, Tasmanian. Three cakes, unbleached.

[In no country, it is supposed, do bees thrive better than in Van Diemen's Land, or prove so productive with little attention; this is attributed to the mildness of the winter season, and the fact that many Tasmanian plants bloom throughout the winter months. The bee has now become naturalised in the forests, and many of the hollow trees are filled with the produce of their labour.]

BICHENO, J. E.

294 Alum, found near Bridgewater. It occurs as an efflorescence in caverns in the clayey rocks.

SMITH, Lieut., R.N.

295 Epsom salts (sulphate of magnesia); found in caverns on the side of the Dromedary Mountain, near the Derwent.

296 Gum of the wattle-tree (*Acacia mollissima* and *Dealbata*).

[Wattle gum exudes in streams during the summer season from fissures and accidental injuries to the bark, and soon hardens into tears and lumps of various sizes. It is equal to the gum-arabic of the shops, and used for the same purposes.]

LIPSCOMBE, F.

297 Ham, cured by Mr. Marshall.

HAINES, J., *Murray Street, Hobart Town.*

Pickles:—

298 Red cabbage. 299 Walnuts. 300 Cauliflower.

301 Onion. 302 Mixed. 303 Tomata sauce.

DENISON, His Excellency Sir W. T.

304 Walking-stick, made of the solid side of the bone of a whale, with round head, turned out of the tooth of the sperm whale.

SCREEN, T.

305 Walking-stick, made of the solid side of the bone of a whale, with head turned, and cut to resemble a man-rope knot.

MILLIGAN, J.

306 Iron ores, from Long Bay.

[These ores occur in a bed about 7 or 8 feet thick, above sandstone, and at the foot of green-stone hills.]

MARRIOTT, Ven. Arch.

307 Walking-stick of the oak of Tasmania (*Casuarina quadrivalvis*).

LIPSCOMB, F.

308 Small round table, of Huron pine, inlaid.

DE LITTLE, R.

309 Galena, from the Tama River.

310 Iron ore; three specimens, found near York River, above limestone.

MILLIGAN, J.

311 Galena, from Macquarie Harbour. It occurs in a vein of mountain limestone, in the channel of Franklin River.

DENISON, His Excellency Sir W. T.

312 Coffee, from Norfolk Island.

MILLIGAN, J.

313 Wood opal, from Salt-pan Plains.

[It occurs in fragments of various sizes, scattered over the surface of the soil, above greenstone and sandstone.]

REES, —

314 Wattle bark, chopped, as it is prepared for the tanneries.

MILLIGAN, —

315 Rock crystal (sp. 25).

[This mineral is found in angular pieces in the peaty soil above granite, and in rolled pieces on the sea-coast of Cape Barrow and Flinders' Island in Bass's Straits.]

MILLIGAN, J.

316 Beryl (*Aquamarine*); 30 specimens, varying from soft to very hard, and from blue to light green, in crystals and fragments more or less rounded and roughened, but having a brilliant lustre on the fracture.

317 Topaz, straw coloured; 300 specimens from Flinders' Island, Bass's Straits, in crystals and fragments, more or less worn, but preserving a high polish and great transparency; hard enough to cut glass.

318 Topaz, yellow; 40 specimens, from the same locality. The crystals exhibit more or less perfectly their natural faces and angles, and possess, with a brilliant lustre, very considerable depth of tint.

319 Topaz, pink-coloured; 30 specimens.

KEMP, GEORGE.

320 Cornelian from the margin of Derwent, opposite Hobart Town.

SHARLAND, W. S.

321 Thread lace, two kinds, made by a girl eleven years of age, at New Norfolk.

REEVES, —

322 Wool. Sample of skin-wool.

323 Sample of skin-wool, scoured.

MILLIGAN, J.

324 Jet, or lignite, from Macquarie Harbour. In the cliffs, imbedded with this, is found a fossil resin, of a deep amber colour and agreeable perfume.

325 Limestone, from the Gordon River, where the formation is traceable nearly 50 miles.

BICHENO, J. E.

326 Limestone from the Mersey River, obtained near the Western Marshes, at a place noted for extensive caverns, between Hobart Town and Bridgewater.

327 Limestone from the foot of the Mount Wellington range.

AKERS, Lieut. R.E.

328 Section of Norfolk Island pine (*Araucaria excelsa*).

SIX, J., *Liverpool Street, Hobart Town.*

329 Pair of dress boots; the legs, fronts, linings, and straps of kangaroo-skin manufactured; and the soles, insoles, &c., of bullock-hide tanned in Van Diemen's Land.

FENTON, Mrs.

330 Honey of 1850.

## DOWLING, H.

331—333 The "Tasmania Calendar" for 1848, 1849, and for 1850.

DENISON, His Excellency Sir W. T.

334 Potash from Tasmanian timbers, 26 lbs.; the result of experiments by the late Captain Stanley, viz., Blackwood, 6½ lbs.; wattle, 6 lbs.; the oak, 9 lbs.; peppermint, 2¼ lbs.; gum (blue), 2¼ lbs.

335 Red ochre, resulting from the decomposition of jasprous ore of iron.

336 Yellow ochre.

337 Specimens of marle.

338 White oak timber (*Lagunea* vel *Hibiscus Patter-sonii*).

339 Specimens of the timber of pine (*Araucaria ex-celsa*).

340 Specimens of iron-wood timber (*Olea apetala*), said to be the most durable.

All from Norfolk Island.

## MILLIGAN, J.

341 Specimen of timber of Oyster Bay pine (*Callitris Australis*).

[This timber is used for agricultural implements and for fittings of houses; it is only to be met with along the coast of the colony.]

342 Specimen of greenstone, from Fingal; central vertical section.

[This is exhibited as a sample of the prevailing overlying rock of Van Diemen's Land, of which all the roads are made, and some houses and bridges are built.]

## BLACKBURN &amp; THOMSON.

343 Model of the bridge across the river Derwent, at Bridgewater, Van Diemen's Land, on the line of road between Hobart Town and Launceston.

[The model is constructed of Huron pine, and is upon a scale of a quarter of an inch to a foot. Erected by the exhibitors from their own design. The model was executed by W. Armstrong, under the direction of W. P. Kay, Esq., Director of Public Works in Van Diemen's Land. The length of this bridge is 960 ft., the breadth of the roadway is 24 ft., and it is raised 9 ft. above the highest high-water level. The bridge is raised upon piles, the total number of which is 363; the piles measure from 65 to 90 feet each in length, and are driven through mud and soft clay, the former 5 to 15 ft. in depth, the latter not ascertained. Continuous with the southern end of the bridge there is a solid causeway, extending to 2,350 ft. in length, with a breadth of 70 ft. The whole length of bridge and causeway is 3,331 ft. The work was begun in 1833, by Colonel, now the Right Hon. Sir George Arthur, and completed in 1849, under the government of his Excellency Sir W. T. Denison, at an entire cost of upwards of 50,000*l*. The navigation of the river has been secured by the construction of a moveable platform, or rolling bridge, at the third bay from the northern shore, 35 ft. in the clear. The longitudinal beams, upon which rests the platform or roadway of the moveable or rolling portion of the bridge, are shod with iron, and travel upon large flanged wheels, fixed upon a pier prepared for the purpose, and the mode of moving this rolling part is by powerful crab-winchies, working on toothed rails fixed on the framing under the bridge, worked by men standing on the moving part and moving with it. The lateral platforms are also moved in and out by crab-winchies fixed on the framing below.]

## THOMSON, JAMES.

344 Coloured sectional elevation of the bridge and causeway at Bridgewater, Van Diemen's Land.

## COUNCIL OF THE ROYAL SOCIETY OF VAN DIEMEN'S LAND.

345 Books and bookbinding; papers and proceedings of the Royal Society of Van Diemen's Land, volume the 1st. Printed by Messrs. Best, and bound by Mr. Rolwegan, Collins Street, Hobart Town. The lithographs by Mr. Thomas Brown, Macquarie Street. Bound in colonial calf-skins, tanned and dressed by Mr. Reeves. Gilt and lettered with gold leaf, manufactured from Californian gold, by Mr. R. V. Hood, Collins Street, Hobart Town.

## WATSON, JOHN, Hobart Town.

346 Plank of blue gum (*Eucalyptus globulus*); length, 146 ft., breadth, 20 in., depth, 6 in.

[The various species of *Eucalyptus* attain generally a great size both in girth and length in sheltered situations, where the forest is thick, where there is no grass, and where injury has never or very rarely been sustained from bush-fires. Blue gum has been measured upwards of 90 feet round near Tolosa, on the northern aspect of Mount Wellington range, and on the southern side, according to the Rev. T. J. Ewing, one of the species has been measured 102 ft. at 3 or 4 ft. from the ground. Another *Eucalyptus*, called stringy bark, exists near the Cam River, on the north coast, measuring 64 ft. of solid timber at 4 ft. from the ground; the tree, having somewhat the form of a four-sided column with its angles bevelled, is 200 ft. to the first limb, where it is estimated to be more than 4 ft. in diameter, giving the enormous cubic measurement in the trunk alone of more than 1,000 tons of timber.]

## GRANT, JAMES, Esq., Tullockgorum, Fingal.

347 Three ram fleeces:—

(1) Fleece from a hogget ram, weighing, after being scoured, 3 lb. 10 oz.

(2) Similar fleece, weighing 3 lb. 11 oz.

(3) Fleece from an older ram, weighing 4 lb.

RICHARDSON BROTHERS & Co., 17, St. Helen's Place.

Specimens of two sorts of wool.

## McLACHLAN, —.

348 Specimens of silicized wood from Van Diemen's Land.

[This magnificent tree was discovered on the estate of Richard Barker, Esq., of Macquarie Plains, Van Diemen's Land, 32 miles from the City of Hobart Town, in the district of New Norfolk; it was 12 ft. high, and imbedded in lava, and distinctly surrounded by two flows of scoria, which at some distant day had brought out the juices of the tree to its surface, and became by a combination of silex, completely vitrified, and surrounded the tree with a glossy surface, the interior of the tree producing opal wood. On a minute examination of the wood by Dr. Hooker, when here in the "Erebus," it has been discovered to be a species of tree not growing in the neighbourhood, and appears to be of the pine or coniferous species. It is conjectured it was originally thrown up by an eruption of a volcano to a considerable height, and came down with its heavy end first upon a bed of sand, and had there remained for ages. In describing the tree he says:—"The manner in which the outer layers of wood, when exposed by the removal of the bark, separate into the ultimate fibres of which it is composed, forming an amianthus-like mass on the ventricle of the stump in one place, and covering the ground with a white powder commonly called native pounce, is very curious." It is 10 ft. high, and when first discovered, 3 ft. 6 ins. diameter, and has been excavated at very considerable expense and labour, and was in a perfectly perpendicular position on the point of a ridge of rocks.]

INCE, W. H., Esq., *Chelsea*.—Proprietor.

349 A list of Australian birds, belonging to the late John Matthew Robert Ince, Esq., commander of H.M.S. "Pilot," and collected during the surveying service of H.M.S. "Fly."

1. *Ptilonorhynchus holosericeus*; male. 2. *Carpophaga magnifica*. 3. *Ptilonorhynchus holosericeus*; female. 4. *Nettapus pulchellus*; male. 5. *Nettapus pulchellus*; female. 6. *Pitta strepitans*. 7. *Nymphicus Novæ Hollandiæ*. 8. *Pezoporus formosus*. 9. *Alcyone Diemenensis*. 10. *Merops ornatu*s. 11. *Chalcophaps chrysochlora*. 12. *Trichoglossus porphyrocephalus*. 13. *Aprosmictus scapulatus*. 14. *Meliphaga longirostris*. 15. *Malurus Lamberti*. 16. *Alcyone pulehra*. 17. *Aprosmictus erithropterus*. 18. *Petroica multicolor*. 19. *Falco frontatus*. 20. *Glyciphila fasciata*. 21. *Chrysococcyx lucidus*. 22. *Ptiloris paradiseus*. 23. *Pachycephala melanura*. 24. *Myzomela erythrocephala*. 25. *Zosterops chloronotus*. 26. *Dierurus bracteatus*. 27. *Platyercus Brownii*. 28. *Geopelia humeralis*. 29. *Euphema pulchella*. 30. *Ptiloris paradiseus*; female. 31. *Halcyon Macleayi*. 32. *Trichoglossus Swainsonii*. 33. *Sericulus chrysocephalus*; female. 34. *Piezorhynchus nitidus*. 35. *Ptilinopus Swainsonii*. 36. *Malurus cyaneus*. 37. *Sericulus chrysocephalus*; male. 38. *Trichoglossus versicolor*. 39. *Melopsittacus undulatus*. 40. *Estrela bella*. 41. *Nymphicus Novæ Hollandiæ*; male. 42. *Malurus Brownii*.

[These specimens illustrate the ornithology of Van Diemen's Land, as well as that of the Great Main of New Holland. The plumage of the *Chrysococcyx lucidus* (21), and the varieties of "Alcyone," are especially beautiful, and admirably preserved.]

M'PHERSON AND FRANCIS, *Hobart Town*. (Agent, W. Francis, Corn Exchange, London.)

350 Sample of wheat, the growth of Van Diemen's Land, weighing 65½ lbs. per imperial bushel.

NEW ZEALAND.

SOUTH AREA, Q. AND R. 32.

A VALUABLE and tolerably extensive collection of native and other products has been forwarded from this distant dependency of Great Britain. Among the raw materials are specimens illustrative of the geology of certain districts. Among these is some copper ore from a small island, distant a few miles from Auckland. To this ore the attention of the miner has already been directed, and a Company has been formed for its extraction. Other specimens from mines differently situated are also sent, and appear to indicate that extensive supplies may in a short time be obtained from this interesting country. Some blocks of lignite and Waikato coal represent some of the stores of mineral fuel possessed by the country. Sulphur and manganese have also been forwarded. The abundant store of iron contained in the iron-sand of Cooper's Bay, Auckland, has at length been made available for the manufacturer; and the first casting at Auckland Foundry in December 1850, has been sent for exhibition. The vegetable produce is also represented by some good specimens, such as those of *Phormium tenax*, or New Zealand flax, bark, dyes, Kauri gum, orchella, timbers, malt, and hops. The manufactures are few and simple, consisting only of coarse cloth, basket-work, leather, and some native curiosities. The following statistical facts relative to this country have been prepared by Captain Collinson:—

STATISTICS OF NEW ZEALAND, 1850.

1. POPULATION.

|                         |                 |
|-------------------------|-----------------|
|                         | <i>British.</i> |
| In Chief Towns—         |                 |
| Auckland . . . . .      | 4,000           |
| Wellington . . . . .    | 4,000           |
| New Plymouth . . . . .  | 1,000           |
| Nelson . . . . .        | 2,000           |
| Otago . . . . .         | 1,000           |
| Remainder . . . . .     | 8,000           |
| Total British . . . . . | 20,000          |
| Total Natives . . . . . | 80,000          |

Total British and Natives 100,000

2. EXTENT.

|                                  |                              |               |
|----------------------------------|------------------------------|---------------|
|                                  | <i>Belonging to British.</i> |               |
|                                  |                              | Square Miles. |
| Arable land . . . . .            |                              | 10,000        |
| Pasture land . . . . .           |                              | 20,000        |
| Remainder: forest, mountain, &c. |                              | 20,000        |
|                                  |                              | 50,000        |

Total, 123,000 square miles, or about the size of Great Britain.

3. PRODUCTIONS.

Wheat, maize, and similar grain; sheep, cattle, pigs, and other live stock; flax, pine timber, copper, sulphur, iron, and coal—by British colonists and natives.

4. EXPORTS AND IMPORTS, 1848.

|                                                    |                     |
|----------------------------------------------------|---------------------|
|                                                    | <i>Imports from</i> |
| Great Britain (manufactures) . . .                 | £5,200              |
| British Colonies (stock and raw produce) . . . . . | 170,000             |
| Foreign Countries . . . . .                        | 3,000               |
|                                                    | £225,000            |
| <i>Exports of Wool, Oil, Flax, Copper, Timber,</i> |                     |
| To Great Britain . . . . .                         | £16,000             |
| To British Colonies . . . . .                      | 22,000              |
| To Foreign Countries . . . . .                     | 5,000               |
|                                                    | £43,000             |

5. SHIPPING.

|                                     |               |
|-------------------------------------|---------------|
|                                     | No. of Ships. |
| To and from Great Britain . . . . . | 9 per annum.  |
| "    British Colonies . . . . .     | 90            |
| "    Foreign Countries . . . . .    | 40            |
| Small coasting vessels . . . . .    | 200           |

6. REVENUE AND EXPENDITURE, 1848.

|                                       |                     |
|---------------------------------------|---------------------|
|                                       | <i>Revenue.</i>     |
| From the Colony . . . . .             | £47,000             |
| Aid from British Parliament . . . . . | 51,000              |
|                                       | £98,000             |
|                                       | <i>Expenditure.</i> |
| Officers of Government, &c. . . . .   | £62,000             |
| Public Works, &c. . . . .             | 34,000              |
|                                       | £96,000 — R. E.     |

1 TYRREL, —.

2 MURCHISON, J. H., 10 *Holles Street, Cavendish Square*—Proprietor.

Copper ore from Kawan, a small island a few miles from Auckland, New Zealand.

3 COLLINSON, Rev. JOHN, *Gateshead*—Proprietor.

Geological specimens from New Zealand.  
Specimen of iron-sand from New Plymouth.  
Small bag made from New Zealand flax, by a lady.  
Flax prepared by the natives; native pattern and dyes.  
Mat of New Zealand flax; made by the natives.

- 4 ROBERTSON, J.  
Specimens of *Phormium tenax*, or New Zealand flax.  
1 Coarsest flax. 2 Owee best cordage flax. 3 Dressed Owee flax. 4 Tihore. 5 Dressed Tihore. 6 Flax dressed by Europeans. 7 Flax in the leaf.  
Specimens of rope and wool-lashing.  
Coil 4-inch warp, tarred. Shark line. Hand lead-line. Coil 4-inch tarred shroud-rope. Coil 3-inch tarred rope. Coil 2½-inch rope, tarred. Coil rattlin, tarred, 1½-inch. Coil wool-lashing. Fishing line, Harbuka. Coils white rope.  
[New Zealand flax is obtained from the leaves of the plant botanically termed *Phormium tenax*. It is indigenous, and flourishes in marshy places. There are several varieties; the coarse is not much esteemed in this country, but the finer kinds are of great beauty and value for textile purposes.—R. E.]
- 5 MCVAY, J.  
Specimens of leather and skins.  
Kip leather. Crop leather. Half-dozen sheep skins. One good sheep skin (not tanned).  
Specimens of barks: Towai, tanning bark. Tanckaha, tanning bark. Hinau, black dyeing bark.
- 6 SMITH, J. A.  
Specimen of soap, manufactured in Auckland.
- 7 ST. JOHN'S COLLEGE, *New Zealand*.  
1 Specimens of cloth and hat. Manufactured by a native lad, aged 17 years, from wool grown, cleansed, carded, spun, and woven, at St. John's College, and dyed with native woods.  
2 Hat manufactured by Nicholas Cod, pensioner, Howick, New Zealand.  
Specimens of basket work:—  
1 Basket, manufactured of Mange Mange, which is esteemed by the natives for its durability. Their eel baskets, made of this, last for a very long period.  
2, 3 Baskets made of supple-jack, obtainable in the New Zealand forests from the eighth of an inch to a foot in diameter. By J. Meagher, pensioner, Howick.
- 8 HARGREAVES, J.  
Specimen of lignite, obtained from the banks of the Tamaki, in the vicinity of Auckland.
- 9 GREENWOOD, W.  
Specimens of coal, showing the strata of the exhibitor's coal mine at Matakana, 15 miles north from Auckland.
- 10 CONNELL, W. (*as Secretary of the Auckland and Waikato Coal Company*).  
Specimens of Waikato coal; distance from Auckland 35 miles, and 10 miles from Manukau Harbour.
- 11 TAYLOR, J.  
Specimens of the copper series from the Kawau Company's mine, Kawau.  
1 Killas. 2 Gossan. 3 Copper ore, from the upper part of the Lode. 4 Manganese, found near the Copper Lode. 5 General character of the copper ore. 6 Copper regulus, No. 2. 7 Copper regulus, best, No. 1.  
[It should be explained that the *Killas* is the clay slate rock in which these minerals occur. *Gossan* is a peroxide of iron, derived in most cases from the decomposition of the double sulphuret of iron and copper, and ordinarily found upon the "backs" of lodes. In many cases the gossans have been found to contain considerable quantities of silver.—R. H.]
- 12 REEVE, J.  
Specimens of copper ore from Messrs. Whitaker and Heale's mine, Kawau.  
1 Yellow ore. 2 Blue ore.  
[The yellow ore is copper pyrites, that is, a sulphuret
- of iron combined with sulphuret of copper, and the term blue ore is sometimes applied to the true sulphuret of copper, called also grey ore, and to the blue carbonate of copper.—R. H.]
- 13 LEWIS, T.  
Specimens of copper ore.  
Specimens from Great Barrier Island Mine, 35 miles N.N.E. of Auckland.
- 14 SMITH, J. A.  
Two specimens from Brodie's mine, Mongonui, 100 miles to the northward of Auckland.  
Specimen of iron sand, obtained in large quantities in Cooper's Bay, Auckland.  
Specimen of sulphur, from White Island, Bay of Plenty, on the east coast of the Northern Island, New Zealand.
- 15 MEURANT, E.  
Specimen of pumice stone, from the banks of the river Waikato.
- 16 BROWN, W.  
Specimen of Kauri gum, obtainable in any quantity in the northern part of New Zealand, ranging from 20 miles south of Auckland to the North Cape.
- 17 GREENWOOD, W.  
Specimens of building stone:—  
Scoria from the vicinity of Auckland, obtainable in any quantity. Stone from Matakana, 15 miles from Auckland: brought to Auckland in blocks of large size, and used in the Ordnance buildings.
- 18 BROWN, W.  
Specimen of limestone, from Wangarei, 60 miles to the northward of Auckland.
- 19 SMITH, J. A.  
Specimens of Roman cement stone, found in large quantities on the banks of the Tamaki.  
Specimen of sharks' fins, which can be obtained in large quantities, and are suited for the China market for a native basket or kit.  
Specimens of flax seed and orchilla weed:—  
1 Flax seed (*Phormium tenax*) for oil.  
2 Orchilla weed, collected in the vicinity of Auckland.
- 20 BALNEAVIS, Lieut. H. C., H.M. 58th Regt.  
Specimen of a New Zealand war pah, on a scale of half an inch to six feet.
- 21 JOHNSON, J.  
Specimens of New Zealand furniture woods:—  
1 Kauri (*Dammara Australis*). 2 Rimu (*Dacrydium cupressinum*). 3 Hakchake. 4 Hakerautangi. 5 Matai. 6 Kakikatea (*Dacrydium excelsum*). 7 Rewa rewa (*Knightia excelsa*). 8 Pohutukawa. 9 Wairangi pirau (or New Zealand sandal wood). 10 Manuka (tea tree). 11 Totara (*Podocarpus totara*). 12 Hakerautangi. 13 Kohe. 14 Hinau. 15 Tanekaha (*Phyllocladus trichomanoides*).
- 22 THE WAIKATO COAL COMMITTEE, *Auckland*.  
Specimen of coal, weighing 2 cwt.
- 23 PURCHAS, Rev. A.  
Specimens of iron ore and limestone.  
1 Iron ore, from Manukau.  
2 Limestone, from Kawhia.
- 24 LOW & MOTION.  
Specimen of native grown maize.  
Specimen of Maori wheat and flour.



- 25 CARADUS, J.  
Specimens of New Zealand flax (*Phormium tenax*).  
1 New Zealand flax, hackled. 2 Net twine. 3 Shop twine. 4 Fishing line. 5 Hand lead-line. 6 Marline.
- 26 KING, Miss, *New Plymouth*.  
Reticule, made of New Zealand flax (*Phormium tenax*), dyed from New Zealand woods, the pattern and work copied from the mat of a New Zealander.
- 27 LIGAR, C.  
Model of White Island, New Zealand. In native sulphur. On a scale of 10 inches to a mile.  
Also a drawing of the place, by C. Heaphy.
- 28 TYRREL, J., Professor.  
Specimens of native flax and wool.
- 29 SMITH, J. A.  
Specimen of oil, from the hump-backed whale, caught at the Bay of Plenty. The sperm and black whales are also caught in New Zealand; but the bottles containing the specimens of their oil have been broken.
- 30 McLEOD, R.  
Specimens of manganese, from Brown and Campbell's land at Waibaka, 15 miles from Auckland.
- 31 Specimen of flour presented by the natives of Rangiarwhia, from wheat grown by Maories, and ground by their own mills (turned by water).
- 32 WHITELEY, Rev. J.  
Specimen of a native box of papa mahuara, in which the natives keep their head dresses.
- 33 TAYLOR, T. E.  
The grub of "Sphinx" destroyed by a vegetable fungus found under the rata tree.  
[It is a remarkable fact that, in the instance mentioned, which is one of not uncommon occurrence, and in others which are on record, the powers of animal vitality have been overcome by those of vegetable organization. The fungus in question penetrates into the entire body of the insect, ramifying to the very extremity of its most delicate and slender organs. For a time the insect lives with its diseased part, but ultimately it dies a victim to the active development of the fungus.—R. E.]
- 34 WHYTLAW & SON.  
Specimen of flax, cleaned by machinery.
- 35 BOURNE, W.  
Specimen of iron-casting. The first casting at Auckland Foundry, 18th December, 1850, cast from iron-sand found in Cooper's Bay.
- 36 McLEOD, R.  
Specimen of salted mullet; can be obtained in great quantities, and well suited for India and China markets.
- 37 MOORE, F. G., 30 *Arundel Street, Strand*,  
Proprietor.  
Lithographic picture of a native village, or Pah, in New Zealand, situated in Cook's Straits. The figures in the foreground are all portraits, and the original large picture now in London was painted in the colony. This picture

is faithfully descriptive of a portion of the beautiful scenery of New Zealand, and of the habits and customs of the natives. It is a valuable record of the early history of the colony, by Professor Gillfillan.

Six water-colour drawings and six steel engravings of New Zealand subjects.

Four native mats or garments.

One greenstone Mari or chief's club. Three specimens of greenstone.

One carved box. One war-club. Native fishing-net and fishing-hooks. Two bottles of insects. Specimens of native grasses. Large map of New Zealand.

38 ARTICLES forwarded from *Wellington, New Zealand*, by the "Lord William Bentinck."

Table-top composed of 19 specimens of Taranaki woods, as per diagram accompanying same.

Sample of Mokau coal.

Native basket containing four hanks of flax, two dyed, one (black) with the hinau.

Flax fishing-line and saddle-girth, native made.

Parcel, 10 baskets made of kie kie, and dyed with hinau.

Puriri, or iron wood. Rimu. Mairi. Miro. Kaiwiria.

New Plymouth iron-sand in its natural state, unwashed.

Packet containing a substance collected from the earth in the town of New Plymouth, supposed to be alum in a very pure state.

Barley from T. Renwick, Nelson.

Malt made and hops grown by Hooper and Co.

Barley and hops grown by H. Martin.

Totara wood. Flax.

Coal from Massacre Bay, taken from an open pit on the beach about eight feet deep, exposed to the action of the sea; the seam is 5 feet thick, and has a dip of about 1 in 7.

Limestone, from same place as coal.

Native fish-hook, made with a shell only. Native mat.

Box of sundries, list enclosed, Rev. R. Taylor.

Footstool, embroidered with New Zealand flax, R. Cameron.

Specimens of dyed flax, R. Cameron.

Specimens of cleaned flax in various stages.

Leather tanned in Wellington with New Zealand materials exclusively.

Baskets made of kareac.

Baskets made of willow grown in the Kent and Cana-gren moss, from the harbour of Port Nicholson, collected by Colonel McCleverty.

Flax, prepared by J. Duncan.

Native knives, formerly used for cannibal purposes.

Picture of Port Victoria, in frame of New Zealand wood, R. Hart.

Hat of native manufacture, and slings used by the natives for carrying burdens.

39 Malt and hops, made and grown by Hooper and Co. Coals from Massoere Bay, taken from an open pit on the beach.

Sandstone, native fishfork and net.

Specimens of dyed flax, tanned leather.

40 LUCAS, R., & Co., 35 *South Audley Street*.

Specimens of New Zealand woods:—Octagon table, top veneered with 11 specimens of New Zealand woods. A sofa table, top veneered with three specimens of New Zealand woods. A small circular inlaid table on three twisted columns, carved claws, &c. A what-not, with twisted columns, veneered with three specimens of New Zealand woods. A what-not, with twisted columns, veneered with one specimen of New Zealand wood. A papitière, with hinged flap and sliding screen panel, fluted with green silk, &c.







