

Rescuing the voices of the past: conservation of a phonograph and a collection of 1900s wax cylinders

AUTHORS: Carmen Bachiller, Erick Arnez, Sara Carrasco, Beatriz Doménech, Celia Vilar, Francesc Fort, José A. Madrid, Maria L. Marín

OBJECTIVES: Conservation of a wax cylinders collection

CONTEXT: Museo de la Telecomunicación Vicente Miralles Segarra. UPV

Actuations



AUDIOS CYLINDERS' RECORDS

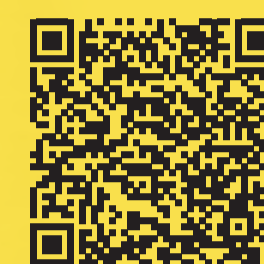

PHONOGRAPH RESTORATION

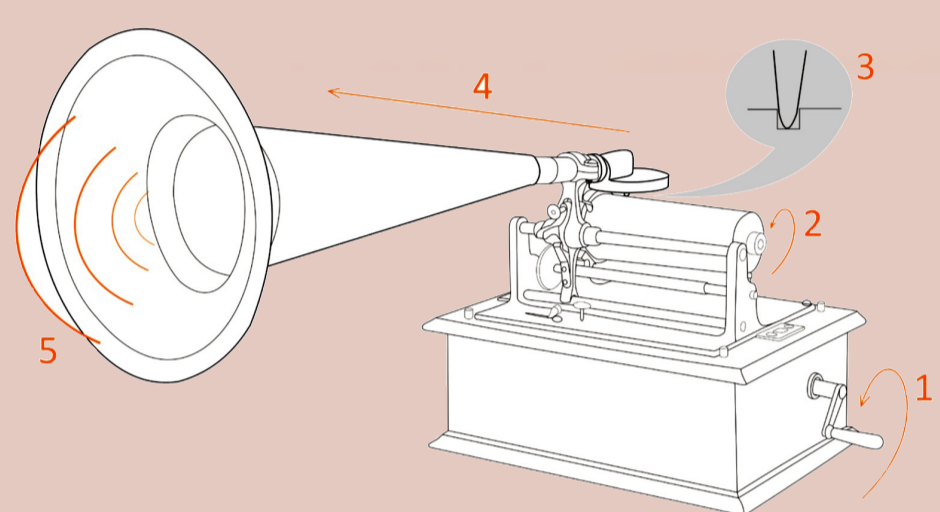

The phonograph was in very good conservation status, but the clockwise mechanism had a broken part that was substituted for a new one.

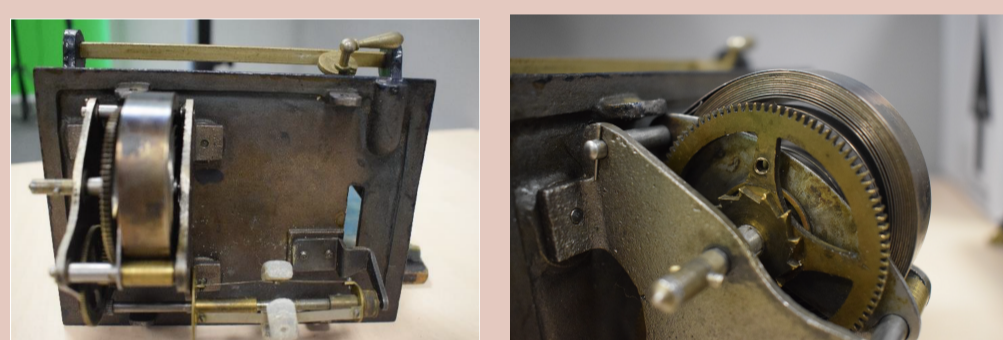

PREVENTIVE AND CURATIVE CONSERVATION OF THE WAX CYLINDERS COLLECTION



DIGITALIZATION AND RESTORATION OF THE AUDIO RECORDINGS



CATALOGATION OF THE COLLECTION

FICHA TÉCNICA			
Descripción del cilindro			
Nº 1	Nombre: <i>Artistas para la habana</i>	Duración: 2:17	
Tipo de cilindro: Negro			
Marca: Viuda de Aramburo			
Tipo de envase: Azul			
Color etiqueta: Azul oscuro			
Estado de conservación del cilindro			
Cilindro:	Bueno		
1	Presenta moho en el borde inferior		
Estado de conservación del envase:			
Envase:	Bueno		
ESTADO	Número de cilindros	Daños mecánicos	Número de cilindros
En perfecto estado	4	Fisuras internas	9
Con daño mecánico	1	Golpes	2
Con daño biológico	33	Fracturas externas	10
Con daño biológico y mecánico	23	Roturas	3

DIFFUSION OF THE COLLECTION

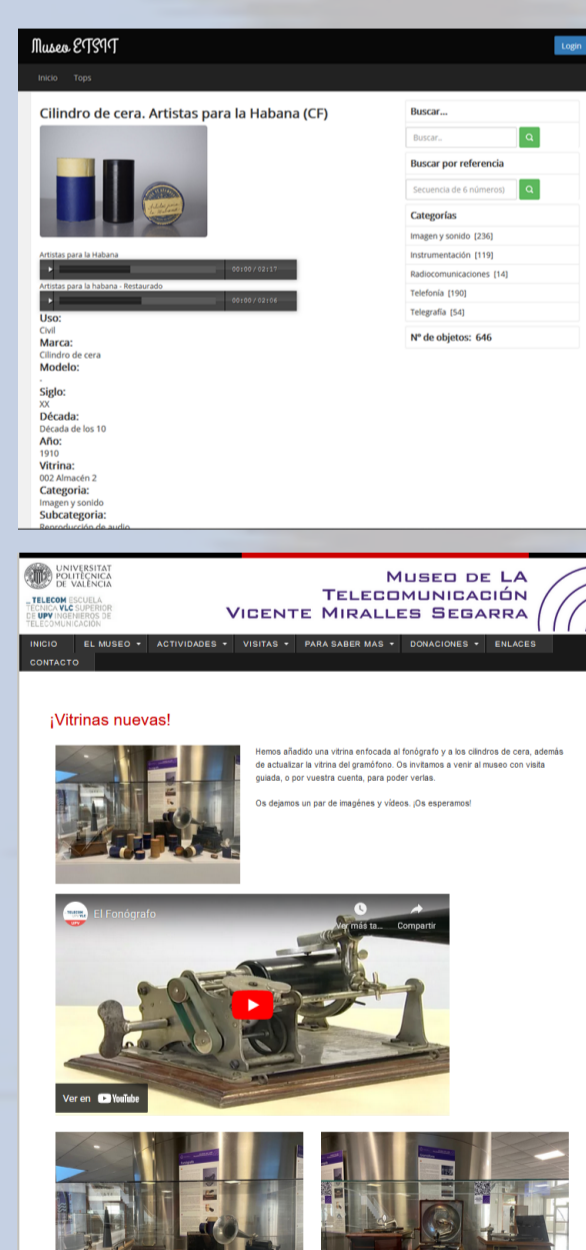

colteleco.webs.upv.es



ca.wikipedia.org/wiki/Tango_del_destripador



museotelecomvc.webs.upv.es

EXHIBITION IN THE MUSEUM

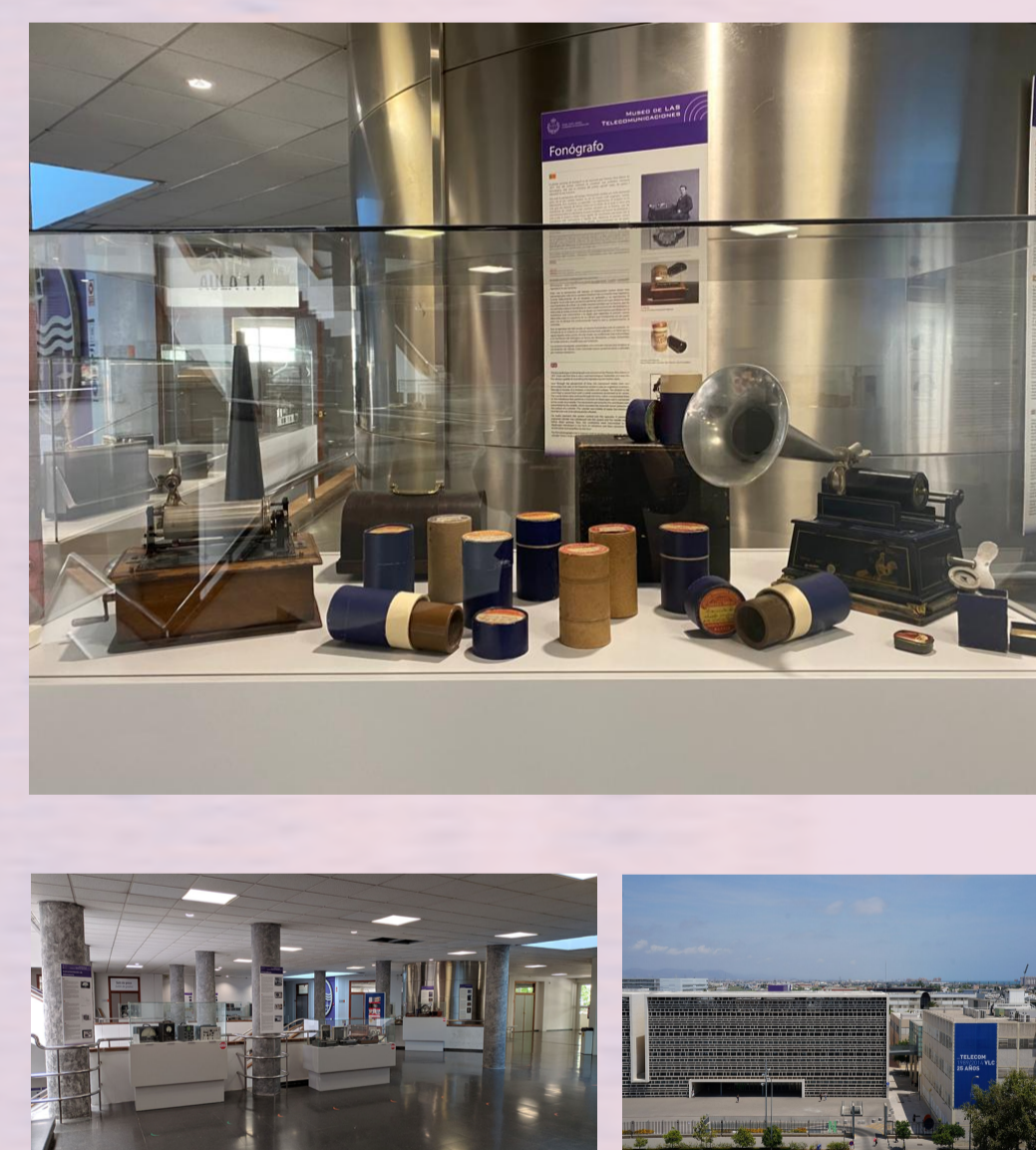

Documentary

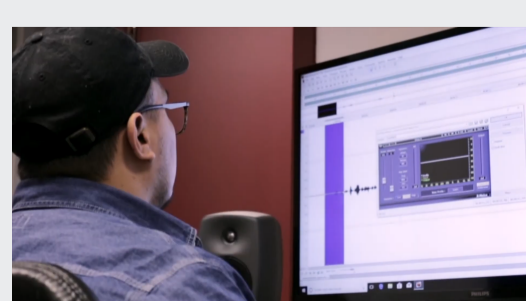
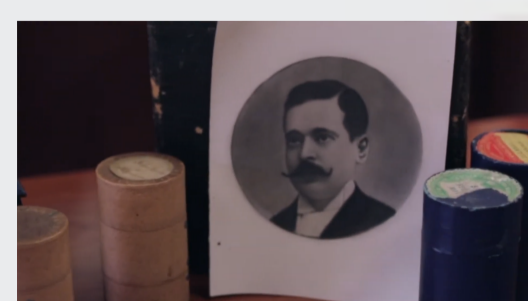
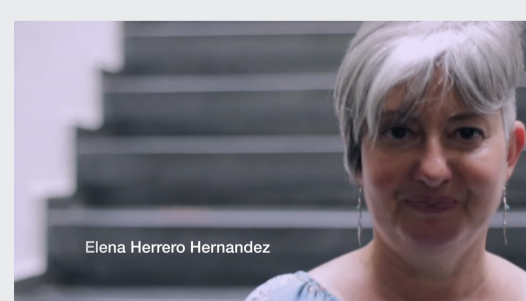

"El fonógrafo" by Erick Arnez

This project shows the history and the digitalization process of the wax cylinders collection donated by Mrs. Elena Herrero Hernández to the Telecommunications Museum of Universitat Politècnica de València.

An Imagina Studios production.

