

U.S. Army Air Corps.

TL 701.  
.U5  
1919b  
Copy 1

939

# PRINCIPAL PARTS OF AIRPLANE ENGINES

---

PREPARED BY THE AIR SERVICE

---

August, 1919

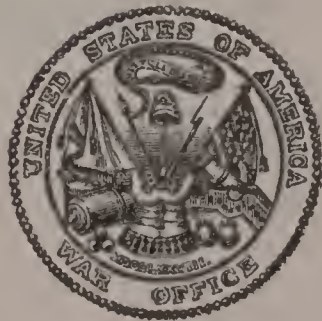

WASHINGTON  
GOVERNMENT PRINTING OFFICE

National Advisory Committee  
for Aeronautics  
Washington, D. C.

WAR DEPARTMENT

Document No. 939

*Office of The Adjutant General*

2

By Exchange New York  
Bureau of Communications & Reports  
March 25 1935

mo 13 5/1/35

TL 701  
.215  
1919 b

WAR DEPARTMENT,  
WASHINGTON, *August 4, 1919.*

The following publication, entitled "Principal Parts of Airplane Engines," is published for the information and guidance of all concerned.

[062.11, A. G. O.]

BY ORDER OF THE SECRETARY OF WAR:

PEYTON C. MARCH,  
*General, Chief of Staff.*

OFFICIAL:

P. C. HARRIS,  
*The Adjutant General.*

3

35-23111



# PRINCIPAL PARTS OF AIRPLANE ENGINES.

## CHAPTER I.—The principal parts and their construction :

- Crank case.
- Rotary motor crankcase.
- Crank shaft.
- Cylinders.
- Cylinders of rotary motors.
- Pistons.
- Pistons for rotary motors.
- Piston rings.
- Piston or gudgeon pins.
- Connecting rods.
- Camshaft.
- Valves.

## CHAPTER II.—Preliminary definitions :

- Numbering the cylinders.
- Rule for determining which way engine will rotate.
- The firing order.
- Items to be observed before taking down a strange motor.

## CHAPTER III.—Definitions pertaining to the action of the engine :

- Defined parts of the crank shaft.
- Crank shaft alignment.
- Propeller thrust to crank shaft.
- The crank path circle.
- The bore of the cylinders.
- A centered engine.
- Dead centers.
- A piston stroke.
- Directions of rotary motions.
- Stresses :
  - The tension stress.
  - The compression stress.
  - The bending stress.
  - The torsional or twisting stress.
- Pressures :
  - Normal pressure.
  - Negative pressure.
  - Positive pressure.

## CHAPTER I.

### THE PRINCIPAL PARTS AND THEIR CONSTRUCTION.

#### CRANK CASE.

A crank case is a cast aluminum or cast aluminum alloy case, generally of the "split type" scraped to a semifinish inside and out, the division of the split or the separation of the two "halves" being horizontal and generally through the main crank shaft center line. Of the two members of the crank case, the "upper half" is the support section and is webbed to give it structural strength. It is sometimes referred to as the "base section." The "lower half" is invariably used as a catchall for oil and contains the oil sumps. It is frequently called the "sump section."

The mating halves of a crank case in a high-grade motor are usually ground to fit; are not interchangeable with each other in a number of motors of the same style and type unless accidentally so, and must be handled carefully during bearing scraping and other motor work so that they may not be nicked or dented upon the mating ground surfaces.

The mating halves of a crank case in a high-grade motor may be only machined at the mating surfaces of the crank case and may require the application of a thin gasket to make the case joint oil-tight. Bear in mind that the application of a gasket changes the distance between the case halves, and that a gasket must not be applied unless the motor is designed to receive one. This also applies to the thickness or thinness of the gasket material used.

Aluminum alloy is very tough and has a very high ratio of expansion. It, however, will not stand very much bending but will withstand severe vibration and strains. Care is to be taken in the placing of any crank case upon the "legs" of a test stand that the supports are level and in a true flat plane; otherwise when the weight of the motor parts is applied and the holding bolts drawn down the crank case will distort and misalign the entire motor. It must be looked upon as the motor foundation, and, like the foundation of any structure, must be true and level.

#### ROTARY MOTOR CRANK CASE.

The crank cases of rotary motors differ entirely from the crank cases of the stationary types and are made of different material. This type of case is discussed under the subject of "Rotary Motors."

#### CRANK SHAFT.

A high-grade alloy steel, drop forged and full machined finished to balance. This steel must be very tough and close grained to withstand the vibration and inertia of the reciprocating parts. The usual difference should be noted between the crank shaft of the automobile motor and the aviation motor. In the former the shafts are not fully machined or as nicely finished, with the result that there are unequal masses of metal which will cause vibration at high speed, probably going unnoticed upon the automobile with its heavy body and steel frame, but which if present upon the airplane would too violently vibrate the delicate structure of the framework.

The special alloy steel is usually made by the use of nickel in different proportions and with the further addition of chromium to obtain the desired quality. Such a steel is termed "nickel-chromium steel." The specifications for it differ with the different makers.

A crank shaft is an expensive unit. It is very necessary that certain parts be very carefully machined, ground, and polished to remove all scratches and to have a uniform thickness, thus to prevent a chance of these parts crystallizing from the large and small places centering the points of vibration.

## CYLINDERS.

Aviation motors differ more widely in the cylinder construction than probably any other assembly unit. There may be said to be four common methods of cylinder making, which can be enumerated as follows:

(a) *The drawn-steel-tubing type.*—The tube drop forged at both ends, one end for the bolting-down flange and the other end for the cylinder-head formation, exhaust and inlet valve ports being welded to the head. The water jacket is formed by being pressed in two halves from sheet steel, then applied to the machine-finished cylinder by welding.

(b) *The cast semisteel type.*—The cylinder is cast from a steel-like compound, similar to the process of casting automobile cylinders, but with the water-jacket omitted from the side walls. The casting is machined to give even thickness of metal and lightest possible weight. The sheet-metal water-jacket is then applied and welded on.

(c) *The cast aluminum-alloy type.*—This class is an aluminum alloy casting of the cylinders in blocks of two instead of the usual single unit. The double head is made separately and bolts on as the removable heads do in automobile practice. The cylinder bore contains a thin metal liner of steel, ground to exact size and pressed in.

(d) *The cast iron type.*—The cylinders are cast in blocks of two of a very fine grade of cast iron, exactly as in the making of automobile cylinders, but of superior material. The water-jacket is integral with the cylinder block.

## CYLINDERS OF ROTARY MOTORS.

The construction of the air-cooled cylinders of rotary motors differs greatly from the above types. This class of cylinder will be discussed under the subject of "Rotary Motors."

## PISTONS.

Pistons are usually a fully machine-finished aluminum-alloy casting. This is the most desirable type, on account of its light weight and heat-conductive properties. It undergoes a large amount of expansion when subjected to the operating heat of the motor, and special allowances of extra clearances must be made for this expansion. Attention should be drawn to the weight and size of the pistons used in an automobile motor and the aluminum alloy type of the aviation motor with their short piston barrels or skirts.

## PISTONS FOR ROTARY MOTORS.

This class of piston is noticeably different from the type mentioned above and will be described under "Rotary Motors."

## PISTON RINGS.

The composition of a ring is usually a dense gray cast iron, fully machine finished, peened on the inner curved surface and exactly ground to size upon the outer curved surface. Some less expensive grades of rings are made by leaving the scale of the casting upon the inner curved surface rather than resorting to the peening for obtaining proper pressure against the cylinder wall. This latter class of ring, though common to automobile practice, may vary too much in cylinder wall pressure when subjected to the high rubbing friction and operating heat of the aviation motor, and is not recommended for service unless for the mere practice of assembly. When the ring becomes very narrow its composition must change to a semi-steel in order to have the proper spring qualities. Whereas, the usual multi-cylinder motor above the "six" has an oblique setting or inclination of the cylinder and the rings must be of the concentric type. The vertical cylinder mounting may permit the use of the eccentric ring.

## PISTON OR GUDGEON PINS.

Pistons or gudgeon pins are almost universally made of a special dense grained steel machined to size, case hardened, and finally grinder-finished to a polished fit. For the sake of lightness the pin is bored hollow. The now approved mounting of the pin is on the principle of fully "floating" it, i. e., having bearing in the end of the connecting rod as well as in the piston bosses with some endwise motion as well. This mounting principle is the result of the use of the aluminum alloy piston. As the piston expands with the operating heat, the bearing "play" increases on the piston pin, loosening it in the bosses. On the other hand, the bronze bushing in the end of the connecting rod, not having the same coefficient of expansion as the end of the rod holding it, tends to seize the piston pin. Thus, with increase in operating head, the piston bosses release the pin and the connecting rod bushing tends to seize it. The fit of the pin must therefore be wonderfully accurate. On the cold motor it is a mild driving fit to the bosses and a bearing running fit to the bushing. Special instruction is required for the removal of the pin from a piston without injury to parts involved.



## CONNECTING RODS.

The rods are usually made of a special alloy steel, drop forged, heat treated and machined to exact weight. With a dense grained steel and I-beam section to rod, wonderful strength is secured for the size used. Quite a variation in the nicety of construction exists between the rods of the average automobile motor and that of the aviation motor. In the former the rods are only machined at the ends, the rough forging remaining throughout the length of the rod proper, thus giving slightly unequal thickness of metal and making impossible an exact rotary balance at high speed.

## CAMSHAFT.

The shafts are usually made of a steel known as "low carbon" but very tough. They are drop forged with the cams integral to the shaft, then rough ground, heat treated, tested for trueness and machined. The shaft is then put in a tank and copperized or copper plated, the parts to be hardened being ground to remove the plating. The case hardening comes next, and only the parts not covered with copper plating will receive the carbon penetration. The shaft is again tested for trueness and finished ground with exact care. The steps of this process give an idea of the value of the shaft and explain also the chances of error in exact cam grinding if the process is hurried for cheapness.

## VALVES.

Valves are usually a ground and machine finished drop forging of a very dense heat-resisting steel. Some processes call for the making of the stem and head separately and a final welding of two together, then the usual machining and grinding to exact size. Valves and valve seats are being constructed on more of a scientific basis each year. With the present day small-bore high-efficiency motors, every small detail adds a small percentage to the final output of the motor. This applies greatly to the valves and much care is taken to exact shape and weights. If the motor is very high speed, the valves must be of light weight or else a very strong spring is required to hold them to their seats and return them to their seats, when opened, quickly enough to comply with the operating cycle of the motor. The valve stem must have wearing quality and the end be hardened. Long stems expand more noticeably under operating heat than short ones, this fact being one of the important considerations in giving the valve its proper stem "clearance" in the adjusting of valves.

## CHAPTER II.

### PRELIMINARY DEFINITIONS.

#### NUMBERING THE CYLINDERS.

On the multi-cylinder motor, each manufacturer usually has his own pet method of numbering the cylinders, which fact becomes very confusing in this work unless regulations of a set nature are adopted. The three following rules, therefore, apply:

(a) The cylinders on the stationary type motor are to be numbered from gear end toward propeller end. If more than one "bank" of cylinders appear, then the bank on the left-hand (facing gear end of motor) bears the odd numbers and the bank on the right the even numbers. Thus the numbers run crosswise from left to right and away from gear end.

(b) The cylinders of the Liberty will receive a special numbering, which will be taken up under "Liberty Motor."

(c) The cylinders of the rotary motors are numbered in regular order as they appear on the crankcase, but, however, opposite to the direction of rotation.

#### RULE FOR DETERMINING WHICH WAY ENGINE WILL ROTATE.

When the motor is brought to the shop, the propeller has been removed and there is nothing of definite nature to indicate its proper direction of rotation. The following rule is to be applied in such cases:

- (a) Rotate the motor slowly in what is thought to be the proper direction.
- (b) Observe the valve operation on some one particular cylinder.
- (c) If the period of the exhaust valve opening immediately precedes that of the intake, the direction of rotation is correct.

#### THE FIRING ORDER.

The firing order of a motor is the order in which the power strokes are delivered from the various cylinders to the crank shaft. In giving the order of firing always start with cylinder No. 1. Place the

cylinder numbers down one after the other as the power strokes occur, thus: 1-2-3-4-7-8-5-6. A rule for determining the firing order may be applied as follows:

- (a) Rotate the motor in the proper direction slowly.
- (b) Observe the exhaust valves only.
- (c) The order in which the exhaust valves open is the firing order of the motor.

#### ITEMS TO BE OBSERVED BEFORE TAKING DOWN A STRANGE MOTOR.

No motor unfamiliar to a mechanic either in type, design, or operating behavior should be disassembled or its repair started without the following data, unless the motor is badly damaged physically or the data is to be furnished from another source.

- (a) Determine its direction of rotation.
- (b) Determine its order of firing.
- (c) Record valve clearance adjustments each cylinder.
- (d) Record valve timing, each cylinder.
- (e) Record fully advanced spark timing.
- (f) Check the compression in each cylinder.
- (g) Make a notation of all missing parts.
- (h) Note condition and quantity of oil removed from sumps and any deposits the oil may contain of a metal-like character.
- (i) Record any special method of arranging oiling pipes, wire connections of the electric system, timing of the starter apparatus, if one present, etc.
- (j) Predetermine, by discussion of the matter, which assemblies are to be removed first and have definitely in mind the whole order of disassembly.

There is a psychological reason why the mechanic who carefully studies the disassembling of the motor will be very capable of its re-assembly. He must have it put up to him that he must take the responsibility, and no one else, of the correctness of the assembly.

## CHAPTER III.

### DEFINITIONS PERTAINING TO THE ACTION OF THE ENGINE.

That a more accurate consideration of the action of an engine may be given, a few minor definitions must follow. By the use of these definitions, explanation is possible without chance confusion as to meaning. The student, therefore, should become very familiar with the definitions.

#### DEFINED PARTS OF THE CRANK SHAFT.

Though the crank shaft is one integral piece of metal, certain designated portions bear different names. Most of these terms are "trade" terms which have been evolved from the shops. The drawing and explanations give more or less clearly their application.

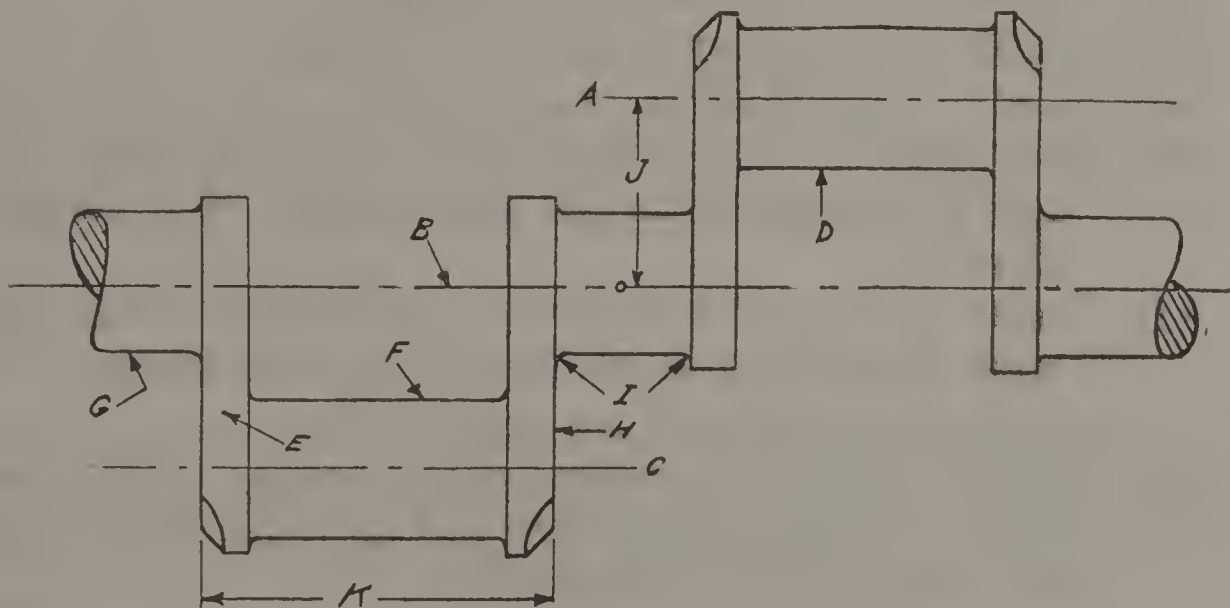

FIG. 1.

The above drawing gives two throws of a multiple throw crank shaft. Thus, a crank shaft is said to be "one throw" or "two throw," etc., the word "throw" being used like a contractor might use the word "brick," it is never pluralized.

A journal is a highly polished portion of the crank shaft, truly circular in section, intended and designed to ride in a bearing. Since a perfectly circular cross section is nearly impossible, a journal is not always as round as it is intended it should be. Wear also brings an "out-of-round" condition. The limit for out-of-round-

ness is 0.0005 inch. When this limit is reached the journal will require regrinding or truing up in some fashion.

The fillets between the journal and web provide means for securing a slight end thrust to the bearing. This end thrust, however, is not enough to counter the end thrust produced by a propeller. A plain journal bearing is strictly a "radial" bearing. It will take loads acting vertically to its centerline only.

The throw measurement, *J*, is taken vertically between the center lines, *B* and *C*.

#### CRANK SHAFT ALIGNMENT.

When the shop mechanic speaks about the alignment of the crankshaft, he generally speaks about the shaft "being in 'line'" or "out of 'line,'" the word "alignment" not being familiar to him. The alignment of a crank shaft is dependent upon three things, for—

- (a) It may be bent, its center line not a true straight line.
- (b) To crank-pin center line skewed; not parallel to the main center line.
- (c) The angle between the throws may not be equal. For example, a two-throw shaft may be intended when in alignment to have its throws directly opposite, but instead the angle on one side may be 183 degrees and on the other 177 degrees. Obviously, the shaft has been slightly "wound up." It has received a severe "twist" or "torque."

#### PROPELLER THRUST TO CRANK SHAFT.

Unlike the crank shaft of the automobile motor, the aviation motor crank shaft receives a large end thrust. This thrust is either a "pull" or a "push." Whether it is one or the other, will depend on whether the motor is mounted as a "pusher" or a "tractor." A tractor propeller pulls itself into the air and is in front of the motor. A "pusher" does exactly as the term implies, and is mounted in the rear of the motor. The same motor may be used as a tractor or pusher merely by turning it around and mounting a different propeller on it. Now, the end thrust of the crankshaft, due to the action of the propeller on it, must be provided with a thrust bearing.

This bearing is usually at the propeller end of the shaft and is of the annular ball-bearing type. It is adjustable by the use of shim-like washers. It should be adjusted so as not to interfere with the shaft alignment with its bearings endwise. In other words, the shaft

must have a certain limited amount of end play. This end play allows for alternate self-adjustment between shaft and crank case bearings due to the effects of heat expansion acting on either one or the other. Say this total end play is one-sixteenth inch, and say, further, that the propeller is a tractor. The propeller will tend to wear the thrust bearing so that the shaft moves toward it, therefore the thrust-bearing adjustment must be such that three-sixty-fourths inch of the total end play is toward the propeller.

#### THE CRANK-PATH CIRCLE.

If any point upon the crank-pin center line be attached and the crank shaft allowed to revolve about its main center line, the point so selected will describe a circle. This circle, the path of the crank pin, is called the crank-path circle. It is a very important circle, as it is by reference to it that the valve timing of a motor is laid out.

#### THE BORE OF THE CYLINDER.

That portion of the cylinder interior which has been machined and ground, finished almost to a polish, circular in cross section, is called the "bore." The bore is also defined as that portion of the cylinder interior forming a guide for the travel of the piston. It is obvious that the bore must be truly circular in form, unscratched, unnicked, or free of any malformation, if the piston rings are to travel freely and gas-tight within the cylinder. The axis or center line of the bore is called the cylinder center line.

#### A CENTERED ENGINE.

Most aviation motors are the "centered engine" type. That is, if the cylinder center line is produced toward the crank case, it will intersect the main crank shaft center line. The intersection will be at right angles. If it should fail to intersect the crank shaft center line, the engine would be called "an off-centered engine."

#### DEAD CENTERS.

When the cylinder center line intersects the crank-shaft center line, it also intersects the crank-path circle at two points. These points, called "dead centers," have distinguishing names. The one nearest the cylinder is called "top center," the one farthest from the cylinder, "bottom center." Reference is also made of them as "top dead center" and "bottom dead center."

## A PISTON STROKE.

As the crank pin travels about the crank pin circle, the piston travels up and down in the cylinder. When the crank pin moves from top center position to bottom center position, the corresponding movement of the piston is called a "piston stroke." A piston stroke is then a total movement of the piston in one given direction. One revolution of the crank shaft produces two piston strokes, one down and one up. Care must be exercised not to confuse a piston stroke with a cycle stroke.

## DIRECTIONS OF ROTARY MOTIONS.

When an observer watches the rotating member of a piece of machinery he generally desires to express the direction of rotation. This is done by stating, as viewed from the specified station point, that the motion is clockwise or counterclockwise, depending on whether or not the motion corresponds with the hands of a watch. With the aviation motor, the motion of the main crank shaft is determined from the pilot's seat, whereupon it is said to rotate either clockwise or counterclockwise. On most motors the propeller is directly connected to the crank shaft, but on some a reduction gear train exists between crank shaft and propeller drive shaft. On this latter class the propeller motion is frequently opposed to the crank shaft motion.

## STRESSES.

When loads or forces act upon the members or parts of an engine they subject the members or parts to a state of strain. Such a state of strain is called a "stress." There are a number of common stresses that the student should be familiar with and which are frequently used in the explanation of motor and airplane parts. The following is a list of the usual stresses:

(a) *The tension stress.*—When an attempt is made to break a rope by pulling on the two ends of it, the rope is being subjected to a "tension stress." This is the stress a bolt receives when it is tightened, pulling two mating flanges together.

(b) *The compression stress.*—If a stick is stood vertically and a load placed upon the top end of it, the stick will be placed under a "compression stress." Such a stress tends to "bow" or shorten the length of the stick. The connecting rod of the motor is built to withstand a great compression stress.

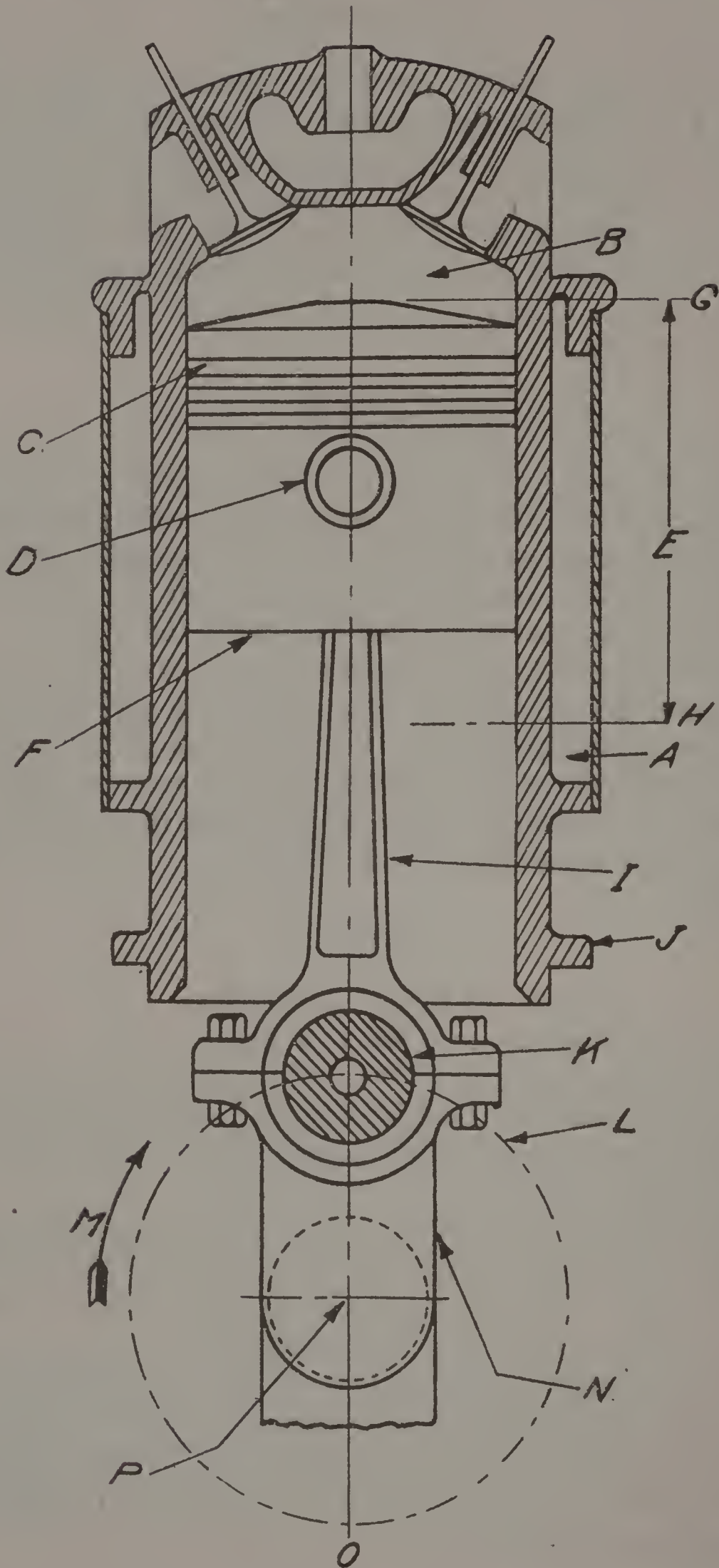

FIG. 2.



(c) *The bending stress.*—If a plank is supported at both ends and a load placed in the middle, the plank is acting against a “bending stress.” In reality a bending stress is the result of the counteraction of two stresses—the compression stress and the tension stress. For if the plank in the above illustration has any appreciable thickness, then as it bends down under the load, all the fibers above its center line will be subjected to a compression, while all fibers below the center line will be subjected to a tension.

(d) *The torsional or twisting stress.*—If a rod is taken in both hands and an attempt is made to twist the rod, wind it up, the rod is resisting a “torsion stress.” This is one of the main stresses the crank shaft receives. It is the stress a line shaft in a shop receives.

#### PRESSURES.

For convenience of explanation, it is often necessary to refer to the “pressure” in the combustion chamber or some other part of the motor. To this end, we explain three general pressure terms in the following which are frequently used:

(a) *Normal Pressure.*—The pressure of the atmosphere at a sea level elevation upon the surface of the earth. This is equal to an average of 14.7 pounds per square inch (760 mm. of mercury in the barometer). Normal air pressure is always recorded as 0-pounds pressure on the steam gauge.

(b) *Negative Pressure.*—A pressure less than a normal pressure and extending toward a vacuum. When the handle of a suction pump rapidly draws the piston up, it subjects the space below the piston to a negative pressure.

(c) *Positive Pressure.*—A pressure greater than normal. It is usually a “bursting” pressure, such as the pressure in a steam boiler, automobile tire, or in the gasoline-engine cylinder during the power stroke.

When an airplane ascends to a great height it encounters an air pressure which becomes more negative in character with relation to the usual air pressure of the earth's surface. This lessening of the air pressure with increase of altitude has an important effect upon the motor.







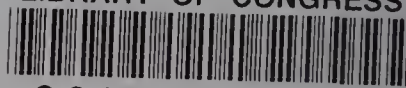

0 033 266 787.7

*Indeped*

	Dept. C. & R.	<i>Source</i>
	Navy Yard, Washington	<i>N.A.C.A.</i>
	Rec'd. <i>Sept. 7/20</i>	