



The Library  
of the  
University of North Carolina



Carnegie Corporation Fund  
for  
Instruction in Librarianship







Digitized by the Internet Archive  
in 2013

<http://archive.org/details/stnicholasserial4921dodg>

# ST. NICHOLAS

AN

ILLUSTRATED MAGAZINE

## FOR BOYS AND GIRLS

---

VOLUME XLIX

PART II.—MAY to OCTOBER, 1922

---

THE CENTURY CO., NEW YORK

Copyright, 1922, by THE CENTURY CO.

## Contents of Part II. Volume XLIX

"ALLIGATOR, A IS FOR." Pictures. Drawn by E. W. Kemble.....	713
AMERICAN ARMY, HOW THE, WAS SAVED BY A DINNER AND A SONG. Story. (Illustrated by John Wolcott Adams)..... <i>Ellen D. Wangner</i> .....	899
APT SCHOLAR, AN. Verse. ......... <i>Ellen Manly</i> .....	1321
BALLOON FLIGHT, THE GREAT. Sketch. (Illustrations from photographs.) .....	<i>Ralph Upson</i> ..... 813
BASEBALL: ALMOST A MUFF. Pictures. Drawn by Charles F. Lester .....	976
BEE, A VAGABOND. Verse..... <i>Clinton Scollard</i> .....	986
BETWEEN TWO DEATHS. Sketch. (Illustrations from photo- graphs.) .....	<i>M. V. Simko</i> ..... 841
BIGGEST TOP IN THE WORLD, THE. Sketch. (Illustrations from photographs.) .....	<i>Harvey W. Root</i> ..... 1163
BLUE ENVELOP, THE. Serial Story. (Conclusion.) (Illustrated by Sarah K. Smith.)..... <i>Roy J. Snell</i> .....	740, 868
BUNNIES, THE GRATEFUL. Verse. (Illustrated by Reginald Birch) .....	<i>Arthur Guiterman</i> ..... 968
CAMPANILE, THE. Verse. (Illustration from photograph.)..... <i>Kathryn Hulbert</i> .....	939
CARNIVAL OF SPRING, THE. Verse. (Illustrated by the author).... <i>Charles F. Lester</i> .....	738
CLASS ELECTION, THAT. Story. (Illustrated by Edward C. Caswell.) .....	<i>A. May Holaday</i> ..... 1078
CLOCKS, THE TWO. Verse..... <i>M. D. Cole</i> .....	1068
CONE GATHERERS, THE. Sketch. (Illustrations from photo- graphs.) .....	<i>Ethel Claire Brill</i> ..... 1308
COVERLID, THE. Story. (Illustrated by Oscar F. Schmidt.)..... <i>Mary Wells</i> .....	922
COWBOY, THE YOUNG. Pictures. Drawn by Charles F. Lester.....	1203
CRATER LAKE, MAROONED IN. Story. (Illustrated by Donald Teague, and from photograph.)..... <i>Alfred Powers</i> .....	1235
DECLARATION OF INDEPENDENCE, HOW THE, WAS FIRST MADE KNOWN TO THE PUBLIC. Sketch. (Illustrations from prints.).. <i>Gardner Teall</i> .....	983
DESTROYERS, THE. Sketch. (Illustrated by Paul Spener Johst, and from photograph.)..... <i>Archibald D. Turnbull</i> .....	956
DRAKE. Verse. (Illustrated by W. M. Berger.)..... <i>Katharine Lee Bates</i> .....	942
DRAKE'S BAY, A VISIT TO. Sketch. (Illustrations from photo- graphs.) .....	<i>J. Smeaton Chase</i> ..... 946
"EAGLE" AND THE "HEN," THE. Story. (Illustrated by C. M. Relyea.) .....	<i>Arthur W. Peach</i> ..... 1281

EMERALD. See "Inca Emerald, The."	
ENVELOP. See "Blue Envelop, The."	
EVENING. Verse. ....	<i>Barbara Poole</i> ..... 1257
FAIRIES, WARNING TO ALL. Verse. (Illustrated by Marion T. Justice.) .....	<i>Hamilton Fish Armstrong</i> .. 804
FAIRY AEROPLANE, THE. Verse. (Illustrated by Albertine Randall Wheelan.) .....	<i>M. F. W</i> ..... 759
FELICIA EXPLAINS—FINALLY. Story. (Illustrated by Donald Teague.) .....	<i>Margaret T. Macdonald</i> .... 1285
FISH CULTURE. Verse. (Illustrated.) .....	<i>John Richards</i> ..... 852
FLAME THAT WILL BURN UNDER WATER, A. Sketch. (Illustrations from photographs.) .....	<i>Robert G. Skerrett</i> ..... 836
FLOWERS, SPRING, OF THE COLORADO DESERT. Sketch. (Illustrations from photographs.).....	<i>J. Smeaton Chase</i> ..... 714
FLOWERS, THE LAZY. Verse.....	<i>Charles Hanson Towne</i> ..... 685
FORESTS, GUARDIAN OF UNCLE SAM'S. Sketch. (Illustrations from photographs.) .....	<i>Wallace Hutchinson</i> ..... 918
FORTUNE. Verse. ....	<i>Mary Carolyn Davies</i> ..... 917
FURNITURE, PEG. Sketch. (Illustrations from photographs and diagram.) .....	<i>Charles K. Taylor</i> ..... 1088
FUZZY'S FURNITURE, THE AFFAIR OF. Story. (Illustrated by Nat Little.) .....	<i>Ethel Ambler Hunter</i> ..... 686
FOREST TROUBADOUR, THE. Verse. (Illustrated by the author.)..	<i>Henry C. Pitz</i> ..... 1302
GOLF: THE ADVANTAGES OF THE LONG GAME. Sketch. (Illustrations from photographs.).....	<i>Jesse P. Guilford</i> ..... 681
GOLF FOR BOYS AND GIRLS. Sketch. (Illustration from photograph.) .....	<i>Cecil Leitch</i> ..... 1313
GOOD NEWS. Verse. (Illustrated by Reginald Birch.).....	<i>Arthur Guiterman</i> ..... 968
GOVERNMENT-OWNED BUILDINGS—WHICH OWNS WHICH? Sketch. (Illustrations from photographs.).....	<i>C. Mitchell Taliaferro</i> ..... 936
HANDICAP, THE. Story. (Illustrated by C. M. Relyea.).....	<i>Brewer Corcoran</i> ..... 1196
"HIDE-Y HOLE" ON THE BEACH, THE. Story. (Illustrated by Nat Little.) .....	<i>Dorothea Castellhun</i> ..... 1017
HILL OF ADVENTURE, THE. Serial Story. (Conclusion.).....	<i>Adair Aldon</i> .....724, 820, 961
(Illustrated by J. Clinton Shepherd.)	
HINT FROM HANNIBAL, TAKING A. Story. (Illustrated by C. M. Relyea.) .....	<i>Merritt P. Allen</i> ..... 1141
HOLLYHOCK FAIRY, THE. Verse.....	<i>M. D. Cole</i> ..... 793
HORSEHAIR, WHITE, A STRAND OF. Story. (Illustrated by E. B. Comstock.) .....	<i>Wallace Hutchinson</i> ..... 919
HOW HE KNEW. Verse.....	<i>Tudor Jenks</i> ..... 756
HUMMING-BIRD'S NEST, THE. Verse.....	<i>Emma Peirce</i> ..... 691
HURRICANE, IN THE WAKE OF THE. Story. (Illustrated by W. P. Couse.) .....	<i>Charles Tenney Jackson</i> .... 1011
INCA EMERALD, THE. Serial Story.....	<i>Samuel Scoville, Jr.</i> ..... 749
(Illustrated by Charles Livingston Bull.)	828, 977, 1090, 1189, 1315

IN THE BLOOD. Story. (Illustrated by I. W. Taber.).....	<i>Kenneth Payson Kempton</i> .....	1069 1204
JADE NECKLACE, THE. Story. (Illustrated by Dudley Gloyne Summers.) .....	<i>Captain John M. Ellicott</i> ....	700
JAY, MR. Verse. ....	<i>Clinton Scollard</i> .....	843
JIMMY DODD PLAYS MIXED DOUBLES. Story. (Illustrated by C. M. Relyea.) .....	<i>Cornelius Brett Boocock</i> .....	787
KEY, THE. Story. (Illustrated by Dudley Gloyne Summers.)....	<i>Beth B. Gilchrist</i> .....	1063
KING OF THE TURQUOISE MOUNTAINS, THE. Story. (Illustrated by Reginald Birch.) .....	<i>Tudor Jenks</i> .....	1058
LAST LAUGH, THE. Story. (Illustrated by George Varian.).....	<i>Harry Starkey Aldrich</i> .....	969
LIMERICKS FROM LYME: THE STEEPLE CLOCK—THE GARDEN. Verse. (Illustrations from photographs.).....	<i>Lucy A. K. Adee</i> .....	812
LINCOLN, MR.—A BOY'S RECOLLECTIONS OF. Sketch. (Illustrations from photographs.).....	<i>Thomas S. Hopkins</i> .....	678
LOCOMOTIVE WAGON, A BOY'S. Sketch. (Illustrated with diagrams.) .....	<i>A. Neely Hall</i> .....	757
"MAJESTIC," THE. See "Ship, The World's Largest."		
MAY-BASKET MELODY, A. Verse.....	<i>Margaret Wheeler Ross</i> .....	673
MAY-DAY IN MERRY ENGLAND. Verse. (Illustrated by W. M. Berger.) .....	<i>Florence Boyce Davis</i> .....	675
MEMORY CHAIN, A. Sketch. Illustrated.....	<i>Ruth H. Withington</i> .....	1084
MERRY-GO-ROUND. Verse. ....	<i>Mabel Livingstone</i> .....	1321
MERRY-GO-ROUND, THE. Verse. ....	<i>Clinton Scollard</i> .....	737
MIND. See "Workshop of the Mind, The."		
MORNING GLORY ADOLPHUS, THE UNDOING OF. Story. (Illustrated by Harold Sichel.).....	<i>A. N. Margaret Campbell</i> .....	853
MOUNTAIN SCULPTURE. Sketch. (Illustrated.).....	<i>Francis B. Atkinson</i> .....	1042
MYSTERY AT NUMBER SIX, THE. Serial Story.....	<i>Augusta Huiell Seaman</i> .....	805 928, 1034, 1165, 1258
OCTOBER, IN. Picture. Painted by Charles Curran.....		
1252		
"ODDSOCKS," THE. Story. (Illustrated by George Varian.).....	<i>Morton Gibbons-Neff</i> .....	1183
OF COURSE YOU WOULD! Verse.....	<i>Arthur Guiterman</i> .....	1251
PETS. Verse. (Illustrated by Reginald Birch.).....		
1083		
PET SHOP, THE. Verse. (Illustrated by Harold Sichel.).....	<i>Clara Ewing Espey</i> .....	730
PHONOGRAPH, THE STORY OF THE. Sketch. (Illustrations from photographs.) .....	<i>William H. Meadowcroft</i> ..	692
PINCH-QUITTER, THE. Story. (Illustrated by C. M. Relyea.)....	<i>William T. Tilden, 2nd</i> .....	905
"PIPES OF PAN ARE BLOWING, WHEN." Verse.....	<i>Edith D. Osborne</i> .....	704
PLANTING YOUR APPLE-SEED.....	<i>Hildegard Hawthorne</i> .....	1304
PLANTIN MUSEUM. See "Printing Establishment, The Oldest, in Existence."		

POT O' MAGIC, THE. Story. (Illustrated by Dudley Gloyne Summers.) .....	<i>Grace Jewett Austin</i> .....	913
PRECIPICE, OVER THE. Story. (Illustrated by George Varian.)...	<i>Louis Allen</i> .....	799
PRINCESS ALONE, THE. Story. (Illustrated by Dorothy Hope Smith.) .....	<i>Sherlock Bronson Gass</i> .....	1272
PRINTING ESTABLISHMENT, THE OLDEST, IN EXISTENCE. Sketch. (Illustrated by Joseph Pennell, and from photograph.).....	<i>Harry Tuck Sherman</i> .....	1266
PROPER MIXTURE, THE. Story. (Illustrated by Donald Teague.).....	<i>Elizabeth Price</i> .....	794
QUEEN, A. Verse. (Illustrated by Reginald Birch.).....	<i>Faith Van V. Vilas</i> .....	705
RABBIT, FARMER, AND DOCTOR TORTOISE. Picture. Drawn by Clifton Meek. ....		1172
RADIO, HOW BOYS PLAY GAMES BY. Sketch. (Illustrations from photographs.) .....	<i>William Telher</i> .....	940
RADIO MESSAGE, THE. Story. (Illustrated by W. P. Couse.).....	<i>George Ethelbert Walsh</i> ....	1128
REMARKABLE SUE. Story. (Illustrated by Donald Teague.).....	<i>Ruth Kathryn Gaylor</i> .....	1123
RIDE TO ORCHARD, THE. Story. (Illustrated by George Varian.)..	<i>L. Dean-Hatch</i> .....	1253
ROBIN REDBREAST. Verse. ....	<i>Kitty Parsons</i> .....	691
"ROSE, THE." Picture. Painted by Lydia Field Emmet.....		827
ROYAL CUP, THE. Verse. (Illustrated by the author.).....	<i>Charles F. Lester</i> .....	1076
SCHOLAR, THE TARDY. Verse. (Illustrated by Mary P. Ludlum.).....	<i>Ellen Manly</i> .....	867
SHIP, THE WORLD'S LARGEST. Sketch. (Illustration from a photograph.) .....	<i>Floyd L. Darrow</i> .....	748
"SHOW," GIVING A. Sketch. (Illustrations from photographs).....	<i>Charles K. Taylor</i> .....	1173
SIR CYRIL'S WINNING SHOT. Verse. (Illustrated by the author.).....	<i>Charles F. Lester</i> .....	1306
SPARROW, THE WHITE-THROATED. Verse.....	<i>Eleanore Myers Jewett</i> .....	819
SPLASH! Sketch. (Illustrations from photographs.).....	<i>George H. Corsan</i> .....	1025
STABILIZER. See "Biggest Top in the World, The."		
SUBMARINE. See "Between Two Deaths."		
SUCCESS AND FAILURE.....	<i>Hildegard Hawthorne</i> .....	1086
SUMMER WORLD, THE. Verse.....	<i>Mrs. Schuyler Van Rensselaer</i> .....	826
SUNLIGHT IN THE WOODS. Story. (Illustrated by Dudley Gloyne Summers.) .....	<i>Comfort Gilder</i> .....	863
THOROUGHbred, THE. Story. (Illustrated by Edward C. Caswell.) .....	<i>A. May Holaday</i> .....	1155
TRAPPED BY THE RED TERROR. Story. (Illustrated by Enos B. Comstock.) .....	<i>Wallace Hutchinson</i> .....	1292
TREES, MY. Verse. ....	<i>Annie Johnson Flint</i> .....	798
TREES, THE BATTLE OF THE. Verse.....	<i>Edith De Blois Laskey</i> .....	1314
TROLLEY, THE STORY OF THE. Sketch. (Illustrated by H. W. Colby, Jay Hambidge, and from photographs.).....	<i>T. Commerford Martin</i> .....	1147
TURNER TWINS, THE. Serial Story.....	<i>Ralph Henry Barbour</i> ....	706, 844
(Illustrated by C. M. Relyea.) .....		947, 1050, 1175, 1296
UNITED STATES—AN ACROSTIC. Verse.....	<i>Kitty Parsons</i> .....	954



UP BY STONY LONESOME. Verse.....	<i>Eleanore Myers Jewett</i> .....	1210
UP-TO-DATE. Pictures. Drawn by A. B. Walker.....		935, 1082
WASHINGTON ELM, THE. Sketch. (Illustrations from photographs.) .....	<i>William H. Bertenshaw</i> ....	955
WEAVER OF DREAMS, THE. Verse. (Illustrated by the author.)..	<i>Henry C. Pitz</i> .....	1134
WHARVES, DOWN AMONG THE. Verse. (Illustrated by I. W. Taber.) .....	<i>Eleanore Myers Jewett</i> .....	1032
WHAT THE LITTLE BIRD SAID. Picture. Drawn by Katherine G. Healey.....		723
WILL HE DARE? Picture. Painted by M. S. Johnson.....		1133
WIND CHANTEY. Verse.....	<i>Helen Coale Crew</i> .....	835
WINNER THAT DID NOT PLAY, THE. Story. (Illustrated by Edward C. Caswell.) .....	<i>Merritt P. Allen</i> .....	718
WONDER THOUGHTS. Verse.....	<i>Faith Van V. Vilas</i> .....	967
WORKSHOP OF THE MIND, THE. (Illustrated.).....	<i>Hallam Hawksworth</i> ....	731, 856
		1135, 1243

## DEPARTMENTS

### NATURE AND SCIENCE FOR YOUNG FOLK (Illustrated):

A Compact Wireless Receiving Apparatus Invented by a Twelve-year-old Boy .....	<i>M. Tevis</i> .....	765
Crater Lake, the Sea of Silence.....	<i>Katherine Louise Smith</i> ....	766
Bandit-Proof Freight-cars.....	<i>Donovan McClure</i> .....	768
Guiding Aircraft into Port at Night and in Foggy Weather..	<i>M. Tevis</i> .....	880
Merula .....	<i>W. W. Arnold</i> .....	881
A Boy's Electrical Device Draws Fishworms from the Soil..	<i>George F. Paul</i> .....	883
Making Thunderbolts to Order.....	<i>M. Tevis</i> .....	992
The Columbine's Joke.....	<i>George A. King</i> .....	993
Insects to Fight Pests.....	<i>H. E. Zimmerman</i> .....	993
The Black-hull Wheat.....	<i>Keith J. Fanshier</i> .....	994
Which Is the Coolest Hat?.....	<i>S. Leonard Bastin</i> .....	995
A Traveling Outfit for Surveyors.....	<i>L. M. Edholm</i> .....	995
Pilotless Aircraft and Seacraft.....	<i>M. Tevis</i> .....	1103
Now Grow Wheat Near Arctic Circle.....		1104
Vices and Virtues of the Cacti.....	<i>J. Smeaton Chase</i> .....	1105
Straw as a Building Material.....	<i>Donovan McClure</i> .....	1106
Apes That Test Money.....	<i>S. Leonard Bastin</i> .....	1107
A Cubical Bubble.....	<i>S. Leonard Bastin</i> .....	1107
The California Road-Runner.....	<i>Edmund C. Jaeger</i> .....	1216
A Wind-Tunnel for Testing Tiny Planes.....	<i>George F. Paul</i> .....	1218
Trapping Insects by the Lure of Light.....	<i>M. Tevis</i> .....	1327
Why Leaves Fall.....	<i>Mark Meredith</i> .....	1327
A Deadly Parasite.....	<i>S. Leonard Bastin</i> .....	1328
A Mooring-Mast for Airships.....	<i>George F. Paul</i> .....	1329
The Petrified Forest on the Mountain-top.....	<i>Bronte A. Reynolds</i> .....	1330

### FOR VERY LITTLE FOLK:

Jamie's Dentist. Story. (Illustrated by Harold Sichel.).....	<i>Lucy Edwards Bruce</i> .....	770
--	---------------------------------	-----

An Adventure. Verse. (Illustrated by Edith Ballinger Price.) .....	<i>H. C. Southwick</i> .....	884
The Drydish Dragon—The Red Balloon. Verse. (Illustrated by the author.).....	<i>Edith Ballinger Price</i> .....	885
A July Jingle. Verse. (Illustrated by Reginald Birch.).....	<i>Ellen Manly</i> .....	996
A Fairy Compromise. Story. (Illustrated by Marion T. Justice.) .....	<i>Clara I. Judson</i> .....	1108
Tom-Tot and the Dwarf. Story. (Illustrated by Harold Sichel.) .....	<i>Edna Groff Deihl</i> .....	1220
The House that Peter Built. (Illustrated by Marion T. Justice.) .....	<i>Nina Hatchitt Duffield</i> .....	1332

THE WATCH TOWER. Conducted by Edward N. Teall. (Illustrated.) .....	760, 875, 987, 1097, 1211, 1322
ST. NICHOLAS LEAGUE. (Illustrated.) .....	772, 886, 998, 1110, 1222, 1334
THE LETTER-BOX .....	781, 894, 1006, 1118, 1230, 1342
THE RIDDLE-BOX. ....	783, 895, 1007, 1119, 1231, 1343

#### FRONTISPIECES

“HAPPY AND FLOWER-LADEN, THEY BRING THEIR FRAGRANT LOADS.” Drawn by W. M. Berger.....	Facing page	673
“PLEASE!—IF YOU WILL LET ME, I THINK I CAN HELP!” Drawn by W. P. Couse.....	Facing page	787
“‘I SEE YOU’RE A LITTLE REBEL,’ HE SAID.” Drawn by Oscar F. Schmidt .....	Facing page	899
“WHEN JACK AND BERT SCANNED THE RIPPLING GULF, THERE WAS NO SIGN OF THE OLD BARGE.” Drawn by W. P. Couse.....	Facing page	1011
“HER FACE FAIRLY BEAMED AS DOUG INTRODUCED HIS FRIENDS.” Drawn by Edward C. Caswell.....	Facing page	1123
“HE WAS MAROONED IN CRATER LAKE!” Drawn by Donald Teague .....	Facing page	1235

4 pt 2 May 17 2

# SUMMER CAMPS FOR GIRLS



Summer Camps for Girls

## Camp Alkyris FOR GIRLS 10 TO 18

A BEAUTIFUL private estate of 15 acres on Sebago Lake, Maine, with 2000 feet of water front. Large pine grove and two private farms of 100 acres. One hour north of Portland. The fifty girl campers live in small groups in log bungalows; large assembly hall. Permanent buildings with every equipment for comfort in ideal camp life. All councilors are graduates of Schools of Physical Education and are women of culture and breeding. Every activity and sport of the modern girls' camp, including motor boating and sailing. References required. For booklet, address

MRS. MALCOLM R. LAWRENCE

Telephone: South 6819

611 Second Street  
Brooklyn, N. Y.



## CAMP NEWAKA

*For Girls. Gold Lake, Colorado*

Between Boulder and Estes Park, in the heart of Nature's Playground. All the activities of healthful camp life, with riding a feature, offered to a limited number. No extras. References required. For booklet, write to

HELEN J. MACDONALD, MARY K. VOORHEES, *Directors.*  
4600 McPherson Avenue, St. Louis, Missouri.



## CAMP HOLIDAY

*Lake Okoboji, Iowa*

Beautiful woodland, chain of lakes. All sports, crafts, gypsy trips and aesthetic dancing. Individual supervision. References required. Junior and Senior Camps. Booklet.

Sara G. Holiday, Burlington, Iowa  
After May 1. Millford, Iowa



(Continued from page 6)

the cities their noisy steel cars filled with happy boys and girls bound for fresh air



land. The huge locomotive which draws them will be as happy as any locomotive can be, and will roll along its way making queer but truly joyful locomotive noises to show its approval. When the summer is waning and the katy-dids for the last time are telling the birch trees that perhaps after all, they "didn't," the big locomotive will come puffing back bringing them all home again. The girls and the boys will be so brown and so rugged and healthy that their own chums will hardly know them.

The growth of the huger city, that expands, and expands, and always forgets to take care of the child, has made the summer camp almost a necessity.

That old dragon Efficiency, which sacrifices every inch of space to brick, and concrete, and stone, that not a second of time may be lost, forgets the children of the city. It forgets that they, too, should have their right to play as well as their elders, who were children before cities began to expand with such cruel greed, as to rob the little ones of the green grass, the blue sky, the trees, the flowers and the music of the birds.

Camp life has worked wonders in turning child life into new channels. The sordid things of the city are more quickly estimated at their lack of worth and the thoughts of the younger generations upon whom the future of national government depends become sweet and wholesome even as their bodies grow strong and rugged in the outdoor world around which no artificial barrier is stretched.



S.N. 5-22

ST. NICHOLAS CAMP SERVICE DEPARTMENT  
353 Fourth Avenue, New York

Please have information about camps sent me.

Name.....

Address.....

Parent's  
Signature.....

My age.....

Location of camp.....

Large or small camp.....

Approximate fee desired.....

Name of camp previously attended.....

Remarks.....

## Summer Camps for Girls—Continued



Senior and Junior Camps for Girls (under 20), Roxbury, Vt.

# Let's Go Horse-Back Riding!

Dear Girls:

4th Letter

One of the best sports for summer time and one that you will remember longest is horse-back riding. Until you have known the companionship of a gentle, intelligent horse and watched the play of rippling muscles under glossy coat; until you have felt the sense of mastery over a live, breathing animal; until you have gulped long, tingling breaths as horse and rider swing along in space-devouring trot or canter; you have not really enjoyed life to the fullest measure.

At Teela-Wooket horse-back riding has become a favorite sport for every camper. Long ago we found that the only way we could be sure of having the best horses each summer was to own as many as we needed. So we purchased one here and another somewhere else with greatest care, until we got together a large number of splendid saddle horses. Each winter they are used by the Wellesley College Riding Club.

Wellesley College girls are well known as finished riders. The instructors who teach horsemanship at Wellesley come to Teela-Wooket each summer. Under their expert guidance, riding soon becomes an accomplishment for every camper. Beginners soon learn enough about riding to leave the ring for pleasant trips along the white roads, and more experienced riders always find some new point in horsemanship, that makes the sport more pleasurable.

When the riders take to the winding roads the whole country becomes their playground.

Hills and valleys yield their mysteries and their hidden beauties. The craving to know what lies behind the crest of some far off mountain or just beyond the bend in the road is easily satisfied when you have a faithful saddle horse to carry you swiftly to these places.

Then, when you have returned to camp, dusty from your long ride, you change to your swimming suit and go to the big pond up the mountain side for a refreshing plunge and a lesson in swimming. Or some other sport calls you to more fun, until at last, you hear the long-awaited bugle call for dinner or supper. All meals are a joy at camp. Not only because they are good themselves, but because you bring to them a real appetite that makes them doubly enjoyable.

Camp life is the only real life for the summer time. Once you have spent your summer in the big out-doors you will agree that no other vacation equals it. And should you join our merry family at Teela-Wooket, you will find many friends to help you get the most out of such a vacation.

If you will write to us, we will send you a booklet showing how the campers at Teela-Wooket enjoy themselves and explaining many interesting things about this fairyland camp in the Green Mountains. Maybe your brothers will be interested in Camp Idlewild on Manhannock Island in Lake Winnepesaukee, New Hampshire. It is a place for a fellow who wants a real vacation. We will be glad to send him a booklet if he will write us.

Very sincerely your friends,

Mr. and Mrs. C. A. Roys  
10 Bowdoin Street  
Cambridge, Mass.





Summer Camps for Girls—Continued

# ALOHA

Camps for Girls Fairlee, Vermont

Three Distinct  
Camps

Ages: 7-13  
13-17 17-30



Aquaplaning

18th season. All sports. Horseback riding. Our aim— a vigorous body, alert mind, and strong character. 2,000 girls have been in camp and not a single serious accident. Aloha Camp for Boys under same management. For booklets, address

MRS. E. L. GULICK

213 Addington Road

Brookline, Mass.



## KINEOWATHA CAMPS FOR GIRLS

ELISABETH BASS, B.A., Director  
Wilton, Maine

Camp Kineowatha,  
Recreation, Girls 8-18.

A camp for girls who seek  
quality, refinement, and  
"real camping experience."

Sports and crafts.  
All safeguards.

Mention which  
camp.



Kineowatha School Camp,  
Tutoring, Older Girls.

Meets needs of girls prepar-  
ing for college entrance  
examinations. Complete  
equipment of Abbott school  
at Farmington, Me.  
Week-end camping trips.

Mention tutoring  
needed.

Irving V. McCall, Hotel McAlpin, New York City



## HANOU M

Camps for Girls



Foothills of Green Mountains. Hill camp for girls under 15.  
Lake camp for girls over 15. Highest ideals of comradeship and  
sportsmanship. Gypsy trips, horseback riding, water sports,  
canoeing. Write for illustrated booklet.

PROF. and MRS. C. H. FARNSWORTH  
Teachers College, Columbia University New York, N. Y.  
All counselor positions filled.



# QUANSET

Cape Cod Sailing Camps for Girls

On Pleasant Bay, South Orleans, Mass.



PIONEER Salt Water Camps Established  
1905. Junior Camp—ages 9-13. Senior  
Camp—ages 13-18. Full fleet of staunch sail-  
boats. Learn to sail in safe Pleasant Bay with  
our cautious Cape Cod skipper. The Quanset  
racing knockabout sails the Chatham Country  
Club Races.

Safe salt water swimming and canoeing—  
experienced instructors always present. Camp-  
craft and trail lore in hands of R. F. Hammatt

(Harvard S. B.), ten years U. S. Supervisor  
of the Shasta National Forest, Calif. Horse-  
back riding, tennis, team games, dancing, music,  
handicrafts, nature study. Strong organization  
of expert counselors. Modern sanitation and  
comforts. Camp farm supplies good whole-  
some food.

The same personal care and supervision by  
the directors.

For booklet, address

MR. and MRS. E. A. W. HAMMATT, Box 10, South Orleans, Mass.

# Camp Tecconnet

The Island  
Camp for Girls

CHINA, MAINE



Regular camp activities, including land and water sports, overnight trips, and horseback riding. For booklet, address

Mrs. CHARLES F. TOWNE

122 Woodland Park, Auburndale, Mass.



## CAMP WINNESHEWAUKA

For Girls

LUNENBURG, VERMONT

In White Mountain region. Mile of lake shore. Free horseback riding, water and field sports, handicrafts, music and dancing under expert instructors. Sponson and war canoes. Screened bungalows. Spring and artesian well water. Perfect sanitation. Best of everything for the best girls. Booklet on request.

HERBERT F. BALCH, Dept. S, St. Johnsbury, Vt.



## The Tall Pines

A Summer Camp for Girls

Camp 7 to 18. Eighth Season. Club over 18.

On Lake George, at Bennington, N. H., the camp nestles among the pines—as healthy a spot as can be found anywhere. Athletics, swimming, boating, canoeing, tennis, basket-ball. Camping trips, mountain climbing. Folk dancing. Special opportunity for horseback riding. Arts and crafts for rainy days. Good food well cooked, home care and attention. The Club accepts Campers for a week or longer. In writing state whether you are interested in Camp or Club. Catalog. Address

Miss Evelina Reaveley, 12A Beacon St., Gloucester, Mass.





# Luther Gulick Camps



On Sebago Lake, South Casco, Maine

MRS. CHARLOTTE V. GULICK, Founder of the Camp Fire Girls  
Hotel Hemenway Boston, Mass.



## EGGEMOGGIN CAMP FOR GIRLS East Harpswell, Maine

Eighth season. On salt water. Horseback riding free. All land and water sports. Experienced supervisors. Junior and Senior Camps, Ages 8-20. Limited enrollment. Resident nurse.

Extra trip with six days on horseback  
Booklets on request. Winter address

Mr. and Mrs. Edward L. Montgomery  
Mount Ida School for Girls - Newton, Mass.



## CAMP TEGAWITHA

FOR GIRLS

MT. POCONO, PA.

An ideal camp in an ideal location in the famous Pocono Mountains—2000 feet above sea level. Electric light, hot tub and shower baths. All land and water sports, horseback riding, tramping, nature study, arts and crafts. Resident physician. Experienced counselors. Wholesome, well prepared food and pure water. Health and safety given first consideration. For booklet, address

MISS MARY ANGELA LYNCH Mt. Pocono, Pa.

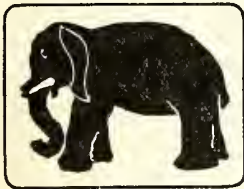

## BLACK ELEPHANT

### CAMP for GIRLS

Lake George, N. Y. 13th Season

Tents, Land Sports, Tennis, Mt. Climbing, Swimming, Canoeing. Woodcraft Council. Booklet sent on request. References necessary. Limited enrollment.

Miss K. B. Wallace, Farlow Road, Newton, Mass.  
Miss T. F. Bush, Dana Hall School, Wellesley, Mass.



## The call to CAMP SERRANA

LAKE TARLETON, PIKE, N. H.

In the foot-hills of the White Mountains, 1500 feet above sea level. Comfortable, protected tents on well-drained hillside. Modern, sanitary equipment. Shower baths. Land and water sports. Mountain climbing, horseback riding, campcraft, nature lore. Tutoring if desired. Trained nurse in residence. Conducted by Mrs. Mary Gaylord Frick. ILLUSTRATED BOOKLET.

Until June 3rd, address

CAMP SERRANA, 559 West End Ave., New York



Seventh Season

GIRLS SENIORS  
JUNIORS

Careful selection of personnel



The  
21st  
Season

# WYONEGONIC

Three Camps  
Ages  
8-21



*The Oldest Camp for Girls*, with three encampments on the shores of a wooded lake in the foothills of the White Mountains. Careful organization and supervision for health and happiness.

*Wyonegonic* once more sends its call to campers who love the out of doors, who find great joy in woods and mountains, in glistening lake and winding stream, who long to join staunch comrades in swims and rides and swift canoes, to sail and row and test their skill in archery and handicrafts, in sports and games and pageantry, to learn the secrets of the woods and know its folk. For illustrated booklet, address

MR. and MRS. C. E. COBB, Denmark, Maine

## Camp Wuttaunoh for Girls



on Crystal Lake  
Canaan, N. H.

Location, equipment and service of the best. Riding, water sports, field sports, tramping, nature work, handicrafts, and social activities. Number limited to 50. Catalog.



Prof. and Mrs. E. A. SHAW  
Northfield, Vt.

## CHUNN'S COVE CAMP For Girls



In the Blue Ridge Mts. Seventh Season. Limited to Fifty Girls. Free Horseback. Water Sports. Overnight Mountain Trips. All Camp Activities. Illustrated Catalog.

Mr. and Mrs.  
E. S. ALLIS  
R. D. 2. Asheville  
North Carolina

## Camp Kenjocketee

"Beyond the multtude"

FOR GIRLS

In the wooded hills of Vermont. Horseback riding over mountain trails. Water sports, canoeing, tennis, golf and field games. Bungalows. Junior and Senior Camps. Address

Mr. and Mrs. James W. Tyson, Jr.  
Box A, South Strafford, Vt.



# CAMP MACDONOUGH

On a quiet little bay of Lake Champlain near VERGENNES, VT.

Girls! What constitutes a Good Time at Camp? OUR ANSWER IS:

1. All round girls to chum with.
2. Counsellors full of the joy of living.
3. Lots of sports and good sportsmanship.
4. Plenty of things to laugh about.
5. Woods and mountains and streams to explore.
6. Plenty of food, deliciously cooked.
7. Beds that make you hug them, they're so good.
8. A camp atmosphere nice and homey and happy.

If you agree with us; send for our catalog. You will find that it will interest mother.

MISS MABEL LAWRENCE EVANS, Director, 618 Union Boulevard, St. Louis, Mo.

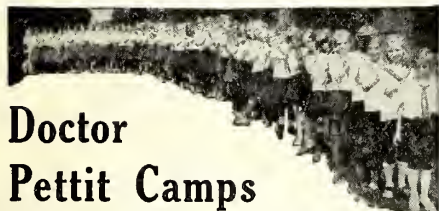

## Doctor Pettit Camps

Three Separate and Distinct Salt Water Camps for Girls at Shelter Island, N. Y.

Extensive water front on two bays. Excellent sailing and all water sports. Riding, woodcraft, field games, hiking, dancing and handicrafts. Wonderful surroundings. 100 miles from New York. 140 miles from Boston.

**MANHANSACK** for Girls 7-13  
**SEWANAKA** for Girls 14-20  
**PECONIC** for Grown People

Mother and daughter or sisters may be near each other while at separate camps. For illustrated booklet address

Henry D. Pettit, M.D.

(27th Year as Camp Owner and Director)

106 Gates Avenue,  
Brooklyn,  
New York

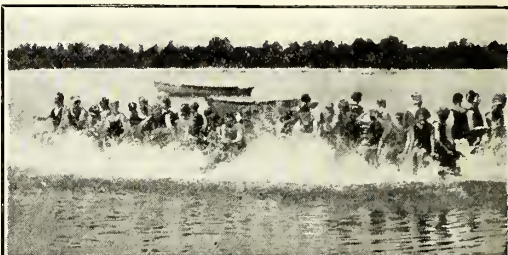
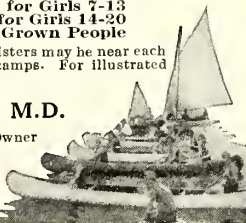

## WINNEMONT

*A Camp for Girls*

On Lake Ossipee, in the foothills of the White Mountains. Special attention to happiness, health and safety. Automobile trips to our White Mountain Camp. Canoeing, swimming, sailing, horseback riding, archery, and all sports. For illustrated booklet, address Mr. and Mrs. W. H. Bentley, Elinor C. Barta, Room 205, 14 Beacon St., Boston, Mass.



Altitude  
1400'  
above S. L.

HELDERBERG MOUNTAINS  
ALBANY CO., N. Y.

Does your girl enjoy *Water Sports*? Does she like *Athletics*? Is she interested in *Handicraft Work*? Would you choose *Experienced College Graduates* to supervise her *Daily Routine*? Do you want her to enjoy an *Ideal Summer Out of Doors*? Then Enroll her at

**Orinsekwa "The Camp in the Pines"**

Non-Sectarian — For further information apply to  
JEANNETTE FRANK, A. B., A. M., 529 West 179th Street, New York

## Wetomachek Camps for Girls

Powers Lake, Wisconsin



Under the management of The Chicago Normal School of Physical Education

Junior and Senior Camps. July and August. For Girls, ages 9 to 22. A strong force of trained counselors. References required.

Write for Booklet, Registrar

Box 18 5026 Greenwood Ave., Chicago, Ill.



## Trail's End *The Kentucky Camp for Girls*

Write for Booklet.

MISS SNYDER, 364 S. Broadway, Lexington, Ky.



## Summer Camps for Girls — Continued



Lake and mountain combine to form a beautiful play-ground for wide-awake girls. Canoeing, horseback riding, swimming, mountain climbing bring wonderful experiences and fun for every day.

## Silver Lake Camps

In the Lake Placid Region of the Adirondacks

Separate Camps

Juniors 8—14

Seniors 14—20

Every convenience for comfortable, pleasant camp life—every necessity for health and safety. Expert directors for every activity. Registered nurse. Open air dining room and sleeping porches. References required. Catalog. Address:

Director, Silver Lake Camps  
Bradford Academy Bradford, Mass.



## PINE KNOLL CAMP

FOR GIRLS

CONWAY, N. H.

On lovely secluded Lake Iona, in the famous Chocorua region of the White Mountains, N. H. Offers every advantage in equipment, management and supervision. Surroundings and associations to satisfy most careful parents and to give its girls "the happiest summers of their lives." Fifty girls, fifteen counselors. Booklet

MRS. FRANCES HODGES WHITE

Dana Hall

Wellesley, Mass.



## Camp Cowasset

North Falmouth, Mass., on Buzzards Bay, Cape Cod. The Seashore Camp for Girls. Senior and Junior camps.

**Seniors:** Canoe and boat trips, use of fine saddle horses and best instruction without extra charge. Pageant, Water Carnival, tennis and games, gypsy trips, handicrafts. First Aid and Camp Paper.

**Juniors:** Salt water sports, careful oversight, *freeriding and instruction*, overnight hikes, nature study, tennis, basket-ball, baseball, volley-ball, dramatized stories, good food, good fun and good care.

Address MISS BEATRICE A. HUNT, Plymouth St.  
Holbrook, Mass.



## CAMP ALLEGRO

Silver Lake  
N. H.

At the gateway of the White Mts. Tents among the pines. Spacious recreation building. New porch dining hall. Individual training by experts in land and water sports. Tennis. Mountain climbing. Horseback riding if desired. Woodcraft. Nature lore. Music. Dramatics. Moderate terms. Write for illustrated booklet. Mrs. Blanche Carstens, 522 Washington Street, Brookline, Mass.

MINNESOTA, Cass Lake.

**KAWAJIWIN** A camp for girls among the pines on famous Star Island. All land and water sports; screened porches for sleeping quarters; library; war canoes; canoe trips; wonderful beach. Only extras, French and tutoring. Seventh season, June 17 to August 26. For illustrated book, address:

MISS WINNIFRED SCHUREMAN, 1780 Lyndale Avenue, South,  
Minneapolis, Minnesota.

MAINE, Lin-e-kin Bay.

**LIN-E-KIN BAY CAMP** Ideal salt water camp for girls on coast of Maine. Limited number. Arts and crafts. Land and water sports; boating; dramatics; dancing; hikes and interesting picnic trips. Booklet.

Mr. and Mrs. G. R. BRANCH, 65 Fruit Street, Worcester, Mass.

## Summer Camps for Girls—Continued



### Wynona

*A Girls' Camp Differing from Others*

Lake Morey, Fairlee, Vt.



**H**APPY GIRLS together roam the Green Mountains or paddle along the beautiful lake. Camping trips and long canoe trips along the Connecticut River. Horseback riding on Kentucky saddle horses. Skilled instructors. Golf, tennis, athletics, swimming. Every day is full of healthful sport. Every feature for comfort and safety. Kiosks among the pine trees. Electric lights, running water. Experienced councilors. 100 campers accepted. Illustrated booklet.

#### WYNONA CAMP

283 Summer Street - Fitchburg, Mass.

(Lake Morey Club—a modern hotel under same management)



### CAMP ABENA

*For Girls*

Healthful, happy camp of absolute completeness, on isolated peninsular, but easily accessible. Juniors (8 to 11 yrs.), Middlers (11 to 14 yrs.), Seniors (14 to 19 yrs.). Separate units. Horseback riding a specialty. Skilled equestrienne as instructor. Four-day canoe trips, always within ten miles of camp. Swimming, baseball, golf, tennis, crafts, dancing, dramatics. Helpful sympathetic councilors. Special trips to Mount Desert, Quebec and other places of interest. Booklet.

**Miss Hortense Hersom**

Biscayne Bay School, Miami, Florida  
After May 1st, Belgrade Lakes, Maine.



### CAMP TWA-NE-KO-TAH

"BEAUTIFUL LIFE-GIVER"

A CAMP FOR GIRLS

Located on 50 acres of picturesque land on beautiful Lake Chautauqua, N. Y., at the gateway of the Middle-West, 1500 ft. elevation. Athletic field, good swimming, screened dining-hall, water-proof tents, big recreation "kiosk," riding, hiking, boating, dramatics, interpretative dancing, handicraft. Girls under 18 years. Junior and Senior departments. Home care, good food and uplifting environment. Councilor positions already filled.

Write for illustrated Booklet

**Rev. R. Carl Stoll**  
5 College Hill, Snyder, N. Y.



*The Spirit of the Camp*



### CAMP AREY

On lovely Lake Keuka, N. Y. (9th Season). A camp unique in its life, spirit and associations. Unusual record of health and development; restricted enrollment, resident graduate nurse. Track athletics, baseball, basket-ball, hockey, crews, horseback riding, all water sports carefully supervised by expert instructors, hikes, camping trips, dramatics, singing and dancing, camp paper, cercle français.

**MRS. A. C. FONTAINE**, Roslyn Heights, N. Y.

NEW HAMPSHIRE, Stinson Lake.

### CAMP EAGLE POINT

High among the White Mts. on Stinson Lake, N. H. Fully equipped for all camp activities, electric light, running water, hot baths, excellent cuisine. Trained leaders. Riding and Touring.

**VIRGINIA E. SPENCER**, Ph.D. Secretary, 220 W. 42nd Street, New York.

### MRS. NORMAN WHITE'S CAMPS

Orleans, Cape Cod, Massachusetts

Located among the pines on Cape Cod. All pleasures of life by the sea. *Owaissa*: for girls 12 to 18. *Mayflower*: for girls 8 to 12. Limited membership.

**Mrs. Norman White**

Tel. Morningside 3350 424 West 119 Street, New York City



## Summer Camps for Girls — Continued



**A**—T LAKE WINNIPESAUKEE.  
**C**—AMP ACADIA FOR GIRLS.  
**A**—LL LAND AND WATER SPORTS.  
**D**—O YOU WISH TO JOIN US?  
**I**—LLUSTRATED BOOKLET.  
**A**—GE LIMIT 8 TO 16 YEARS.

DR. and MRS. J. GRANT QUIMBY, Lakeport, N. H.

14th  
Season

## Camp Otuit

For girls of 9 to 20. Beautiful location on Cape Cod with fresh and salt water swimming under expert instructors. Healthful and body building as well as enjoyable. Tennis, canoeing, all field sports and games. Horseback riding under the careful supervision of Mr. W. A. Laing, of the Halcyon Hall Riding Academy. Tutoring if desired. Limited enrollment. Catalog. Address

Miss Emma L. Schumacker  
 Care Miss Beard's School  
 Orange, N. J.

MASSACHUSETTS, West Springfield.

**CAMP YOKUM** For Girls. Situated on the shore of a beautiful lake almost at crest of Berkshire Hills. Altitude 1875 feet. Best of instructors, attractive responsible counselors. Term seven weeks. \$200 includes everything except tutoring and horseback.  
 MARY E. RICHARDSON, 69 Woodmont Street.

LONG ISLAND, Bellport.

## CAMP GRANGE

Under the direction of experienced Directress and Counselors. Limited to fifty girls, 5-16 years. Fifty acres. All sports; ocean and still water bathing. For catalogue, address

MISS C. B. HAGEDORN, 606 West 137th Street, New York City

PENNSYLVANIA, Philadelphia, 404 W. School Lane.

## PINE TREE CAMP

For Girls. On beautiful Naomi Lake, 2000 feet above sea, in pine-laden air of Pocono Mountains. Four hours from New York and Philadelphia. Experienced counselors. Horseback riding, tennis, baseball, canoeing, "hikes." Handicrafts, gardening, 11th year.

MISS BLANCHE D. PRICE.

VIRGINIA, Bristol.

## CAMP JUNALUSKA

One of the finest "all around" camps for girls in the south. Lake Junaluska, N. C., the "Land of the Sky." Swimming, canoeing, mountain climbing, horseback riding, dancing, handcraft, music and dramatics, all under careful supervision. Write for booklet.

Miss ETHEL J. McCoy, Director, Virginia Intermont College, Bristol, Va.

# ONEKA

The Pennsylvania Camps for Girls

Junior and Senior Camps on crystal Lake Arthur in the heart of the highest Poconos. Elevation \$200 ft. All tents on lake shore. Rustic bungalows. Splendid Equipment for all land and water sports. Large athletic field. Hockey. Horseback Riding. Gypsy trips. Handicrafts. Dramatics. Pageantry. Music. Woodcraft. Development of personality and self-reliance.

Mr. and Mrs. Sipple give personal care to each girl. Number limited. Associated with CAMP LENAPE for BOYS. Booklet.

MR. and MRS. ERNEST W. SIPPLE  
 350 West Duval St., Box A, Germantown, Phila., Pa.



## Camp Farwell

Upper  
Camp  
Girls  
14-20

Lower  
Camp  
Girls  
7-13

For girls who love the woods, the hills and a rollicking good time in the open. Camp Farwell girls know the joys of following trails, of the straw ride, of swimming, boating, horseback riding. Magnificent camp setting by mountain lake in pine woods. White Mountain views to East, Green Mts. to West. Bungalows, tents, electric lights, hot and cold running water. Careful supervision. Illustrated Booklet. Until June 20 address Miss Rosalie P. Sanderlin, 2814-27th Street, N. W., Washington, D. C. After June 20, Wells River, Vt.

# NESHOBE

A Camp For Girls

(Clear Water)

On Fairlee Lake, So. Fairlee, Vt.

Nine weeks of joyous living in the open. Wonderful location. Attractive bungalows. Horseback riding, hiking, all usual camp athletics, water sports, handicrafts and nature work. Careful personal supervision over all.

Write for illustrated booklet

MR. and MRS. EDWARD G. OSGOOD  
 300 Chestnut St., Clinton, Mass.

MASSACHUSETTS, Falmouth.

**MARICOPA CAMP** A camp for young girls (7-14 yrs.) at Falmouth, Mass., among the pines and dunes of Cape Cod, the most invigorating climate in U. S. Experienced counselors. All outdoor sports. Number limited. Write for booklet.

Mrs. L. C. Wood, 451 W. Bringham St., Germantown, Philadelphia.

## Summer Camps for Girls—Continued



# WYODA

A "Home Camp for Young Girls"  
Lake Fairlee, Vermont

New bungalows, 130 acres, sandy beach, main house, open-air dining hall (screened), Tennis and basketball courts. Large athletic field, riding, swimming, canoeing, weaving, handicraft, woodcraft, dancing, dramatics, nature study, mountain trips, tutoring.

Mr. and Mrs. Harvey Newcomer  
Lowerre Summit Park  
Yonkers New York



# CAMP IDLEPINES

On Bow Lake

Careful instruction in all land and water sports. For catalog and details, write

MISS SCOTT, 1102 Times Bldg., New York, or  
Chicago Representative, Room 1515  
at 159 North State Street

# CAMP WINNAHKEE

FOR GIRLS

ON MALLET'S BAY, LAKE CHAMPLAIN <sup>7th</sup> Year

America's Beautiful "Inland Sea"

AMONG the pines of Vermont, where the air is a tonic and the very earth a friend. Oh, what a wonderful place for an outdoor summer brimming with fun! All land and water sports—Riding, motor-boating, dancing, dramatics, handicraft, jewelry, basketry. Experienced counselors.

Trained nurse. Booklet.

MRS. WM. H. BROWN  
307 West 83d St., N. Y. City



# CHINQUEKA CAMP

For Girls  
Among the Litchfield Hills

On  
Bantam  
Lake  
Conn.

A healthy, happy, helpful vacation place for thirty girls, 8 to 14, under home influences. Woods, fields and lake at 1000 ft. elevation. Land and water sports. Careful training; sympathetic comradeship. Teuts, lodge, cottage with modern plumbing. Abundant table with farm and dairy products. Moderate rates. 8th Season. Booklet.

David Layton, Director, 669 Dawson St., New York City



CONNECTICUT.

# CAMP NEHANTIC FOR GIRLS

A salt water camp. Sea shore and country combined. Bathing, fishing, crabbing, land and water sports. Experienced physical training director in charge. \$190.00. Booklet. Mr. and Mrs. HARRY DAVISON, 5333 Rising Sun Ave., Philadelphia, Pa.

# Camp Idyle Wyld

FOR GIRLS

## Three Lakes, Wisconsin

A song for every activity. Will you help us sing?—

*"Go, roll your bedding up again,  
We'll make another camp.  
A fishing pole, o blanket roll,  
A poncho for the damp.  
Get ready for a truck trip,  
Or a paddle, or o tramp,  
All up and down we'll go compting."*

Limited numbers; few vacancies; highest references required. Fees, \$500, including railroad fare.

NEW HAMPSHIRE, Portsmouth.

# CAMP BEAU RIVAGE

(French Camp for Girls)

All sports by land and sea. Address Secretary  
57 East 74th St., New York City.



MAINE, Oxford.

Navajo on Lake Thompson, July 1st—Aug. 27. Terms \$250 (no extras). The Camp of high standards, for fifty girls. Girls 8-20 years. All land and water sports. Handicraft, Hikes. Two-day White Mt. trip. Every care of director and experienced counselors. Nurse, Registrar early. Catalog. CLARA HENDERSON, Director, 1619 Eutaw Place, Baltimore, Md. (until June 20).

WISCONSIN, Green Lake.

# SANDSTONE CAMP

Eleventh season. Three divisions, ages 8 to 24. More activities offered than in any other camp in the west. Thirty specially trained counselors. A Camp where only the best satisfies. Address

ESTHER G. COCHRANE, 3722 Pine Grove Avenue, Chicago.

WISCONSIN, Rhinelander.

# CAMP BRYN AFON FOR GIRLS

1600 feet above sea level. Screened Sleeping Bungalows with hardwood floors; Saddle horses; Athletic Field; Craft House; All land and water sports; Counselors College Women. All Positions filled. Booklet.

LOTTA B. BROADBRIDGE,

The Palms, 1001 Jefferson Ave., Detroit, Mich.



## Summer Camps for Girls—Continued



### CAMP WI-HA-KO-WI NORTHFIELD, VERMONT

Girls' camp in the Green Mountains on line of Central Vermont Railroad, where health, happiness and helpful activities abound. Experienced counsellors, swimming, hikes, athletic games, horsemanship, arts and crafts. Price \$150.00 for two months. Write for illustrated catalog.

Prof. and Mrs. A. E. Winslow, Northfield, Vt.



### CAMP MYSTIC CONNECTICUT "MISS JOBE'S CAMP FOR GIRLS"

The salt water camp for girls. Half way between New York and Boston. Life in the New England hills, woods, and by the sea. Unusual buildings, tent bungalows, tennis courts. Shower and tub baths. Modern sanitation. Salt water sports, motorboating, swimming, safe canoeing, horseback riding, dancing, field athletics, arts and crafts, dramatics. Camp life and trips under the personal direction of Miss Jobe, who has had ten seasons of practical experience (summer and winter) in camping and exploration in the Canadian Rockies. Care for the safety and health of each camper. Juniors and Seniors. Age 8-18. Ill. booklet.

MARY L. JOBE, A. M., F. R. G. S.  
Room 63, 50 Morningside Drive, New York

### CHAMBERS ISLAND

"3000 Acre  
Camp for  
Girls"



The gem of the Great Lakes. Present owner's former summer home. Fine buildings. Two hundred wild deer—Golden pheasants. Interior lake for aquatic sports. Basketball, Tennis, all other sports, directed by experienced councillors. Arts and Crafts, Dancing, Music, Dramatics, Horseback Riding. All modern conveniences. Limited enrollment. For booklet and information, address

Mrs. Edward J. Barrell, Pres., 222 Michigan Avenue, Sheboygan, Wisconsin

### SARGENT CAMPS

PETERBORO, N. H.

*The Athletic Camps for Girls*

Promotes a healthy, happy, useful life. Skilled leaders. Woodcraft, water sports, hiking, horseback riding, games, dramatics, music, dancing.

**Senior Camp** for girls 15 to 20.

**Junior Camp.** Unexcelled equipment and care. Homecraft for little folks.

**Sargent Club.** A distinct unit with all camp privileges for girls over 20. Campers accepted for two weeks or more. July to September inclusive.

For illustrated booklet address **Camp Secretary,** 8 Everett Street, Cambridge, Mass.



NORTH CAROLINA, Sapphire.

### CAMP MERRIE-WOODE

(Formerly Lake Fairfield Camp) On Lake Fairfield, Sapphire, North Carolina. In the Blue Ridge Mountains of Western North Carolina. Elevation 3200 feet. Always cool, no mosquitoes. Ideally equipped. Beautifully located. Modern sanitation. Most carefully chosen leadership. *A camp with everything a girl likes, and every safeguard and advantage that particular parents could desire.* All land and water activities, including horseback riding. One fee, no extras. Write for illustrated booklet. DR. JONATHAN C. DAY, *Advisory Director*; Mrs. JONATHAN C. DAY, MARY HUSTON TURK, *Directors*; Address, until June 10th, 790 Riverside Drive, New York City.



### CAMP OWAISSA

On Indian Lake, Adirondacks

With all the delights of water, mountains and woodland—the place for a girl who wishes to be a real camper. Post office, Sahael, N. Y. For Booklet, address

Miss Sallie E. Wilson, Box S

National Cathedral School, Washington, D. C.

NEW YORK, Middle Island, Long Island.

### CAMP SEEWANAKAH

A girls' camp on Long Island, two hours from New York by motor. All regular crafts and sports. July first to end of August. Two hundred dollars the season.

MISS G. C. FREEMAN, 198 Barclay Street, Flushing, N. Y.

## CAMP CHEQUESSET

*The Nautical Camp for Girls  
On the Tip of Cape Cod*

All the fun of life in and on Wellfleet Bay. Exploration of the wonders of the sea. Wood lore, arts and crafts, scouting, camp crafts. All field sports. *This is the Pilgrim Camp in the Pilgrim Land, doing the same things and taking the same trips that the Pilgrims did.*

**Real sailing with a skilled sea captain**

Aquaplaning, motorboating, swimming, fishing, nautical cooking, bungalows. Crew system with every girl a leader. Each girl always in the care of an expert. Camp limited to thirty-eight girls, with a councillor for every three. Write for illustrated booklet.

**Professor and Mrs. WILLIAM G. VINAL, A.M.**  
Box 25, R. 1. College of Education, Providence, R. I.

**No positions open for councillors**





Send for **CAMP AMERICA** *Descriptive Book*

*SOME OF THE FEATURES:*—Forty-acre Sport Field—900-acre Estate—Its Own Farm—Pure Drinking Water—Boating—Swimming—Horseback Riding—All the Field Sports—Nature Study—Arts and Crafts—Fine Arts—Electrically Lighted—Tub and Shower Baths—Perfect Sanitation—Seven Tallyhos—Dancing—Moving Pictures—Radio Outfit—Large Assembly Halls—Only Balsam Grove in Vermont—Substantial, Permanent Buildings—Attendant Physician—Nurse—Dentist—Bowling Alleys—Abundance of Wholesome Food—Opens for Fourth Season June 29, 1922.

Send for Beautiful Descriptive Book of

**CAMP AMERICA**

Lake St. Catherine

For Girls

Poultney, Vermont

**COME TO QUINIBECK LAKE FAIRLEE VERMONT**

ITS AIM: To make Girls healthy and strong, happy and contented, self-reliant and self-restrained.

For Information Address  
**WILLIAM W. CLENDENIN, A.M.**  
 120 Vista Place Mt. Vernon, N.Y.



**WINNETASKA**

THE CANOEING CAMP FOR GIRLS

SQUAM LAKE, ASHLAND, NEW HAMPSHIRE

**DR. and MRS. JOHN B. MAY**

WINNETASKA LODGE, COHASSET, MASSACHUSETTS

**SELECT THE BEST CAMP**

for your boy or girl. We shall be glad to help you choose the right camp in the right environment. State age, location preferred and rate. Experienced counsellors. **NO CHARGE.** Address

Mrs. M. REGINA JONES, *Director School Service,*  
 THE NORTH AMERICAN, Philadelphia.



# SUMMER CAMPS FOR BOYS



## **CULVER** SUMMER SCHOOLS

(On Lake Maxinkuckee)

Navel, Woodcraft, Cavalry, Artillery, Aviation

**D**OING things—real things, living like a boy wants to live in the summer time. That is the Culver way. Days of fun from morning to night, out in the open. Riding in the Cavalry Troop, across country, camping out at night, around the camp fires like real cavalry men. Or firing the big "75's" when the artillery takes the field. Sailing on Lake Maxinkuckee in regular navy cutters under the command of a retired U. S. Admiral. Zooming through the air in a hydroplane. Scouting, canoeing, swimming, playing baseball, tennis, and the hundred other sports that make a fellow happy. No other place can offer all that Culver has for a summer brimful of healthful fun.

The ideals and traditions of Culver carry over with the summer courses, vitalizing its myriad of absorbing activities and giving boys something that stays with them far beyond a coat of summer tan.

Because Culver is not conducted for profit its usual opportunities may be had at a price not exceeding those of the average camp.

For catalog of any school address

**The ADJUTANTS AIDE  
CULVER, Indiana**



## Camp Idlewild



### ON MANHANNOCK ISLAND LAKE WINNEPESAUKEE, N. H.

**W**HERE A BOY LIVES his summer vacation in boy fashion. Out of doors, in the woods, on the water, around the campfire, swimming, biking, canoeing, playing baseball, tennis and doing just the things a live, vigorous boy wants to do. All activities under expert guidance. Complete equipment for healthful, comfortable camp life. Good food, fresh meats, milk and vegetables in abundance. Separate camps for juniors and seniors. The autumn camp is a new special feature.

Write for illustrated catalog.

**L. D. ROYS, 10 Bowdoin Street,  
Cambridge, Mass.  
Teela-Wooket Camps for Girls, Roxbury, Vt.**

# WEQUAQUET

## The Cape Cod Camp for Boys

Ages 9-15

Located near Barnstable, midway between Plymouth and Provincetown, combines

Lake Woods Country Seashore  
and offers every form of  
Fresh Water Land and Salt Water Sport.

A small select camp with a big purpose, limited to thirty boys and emphasizing individual development. During the summer a series of delightful and instructive trips is taken to all points of historic interest on Cape Cod. For illustrated booklet, address

The Director, 37 St. John St., Jamaica Plain, Mass.  
Telephone—Jamaica 1639-M.



## CAMP ★ VEGA

CHARLESTON LAKE  
ONTARIO, CANADA

(Only 12 hours from New York City)

A select Camp for Boys, Limited number; Highest type of College councilors from Yale, Columbia, Springfield, Pittsburgh, Ohio State, Univ. of Toronto and Centre College of Kentucky. 1000 mile radio receiving set. Radio instruction. One of the finest equipped camps in America. Personal supervision guaranteed. Bungalow camp. 4 motor boats, sail boat, excellent fishing. Doctor and trained nurse always in camp. References required. For booklet or personal call by the Director, write

WILLIAM S. HAZEL  
16 West 47th Street New York City

## ASH-NO-CA

"A BOYS' CLUB"

IN THE MOUNTAINS OF NORTH CAROLINA

Not a school, not a camp, but a place planned, equipped, and conducted for the pleasure and physical and moral welfare of boys under seventeen during the summer. Delightful climate. No mosquitoes. Sports include hiking, mountain climbing, camping, canoeing, swimming, boating, tennis, baseball, track, golf, EVERYTHING A BOY LIKES. Fine buildings furnish healthful sleeping accommodations and other buildings ample place for recreation in wet weather. Boys have best possible care. Large farm furnishes abundance of wholesome food. 714-acre Tract.

Address George Jackson, Asheville School - Asheville, N. C.



## Camp Sokokis

Bridgton, Maine. On Long Lake in the foothills of the White Mountains. Small home camp. "An acre per boy." Radio, Shop-work, Photography, Marksmanship. Land and water trips. Sleeping bungalows. Booklet.

Lewis C. Williams 98 Rutland Road, Brooklyn, New York  
Telephone Flatbush 3774

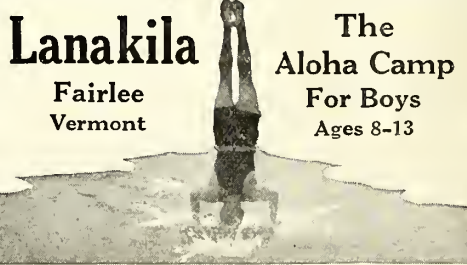

## Lanakila

Fairlee  
Vermont

The  
Aloha Camp  
For Boys  
Ages 8-13

### Aquaplaning

On Lake Morey. All water sports including motorboating and aquaplaning. Athletic fields. Horseback riding. Woodcraft. Treasure hunts. Craft shops. Vigilance for health and safety. Aloha Camps for Girls under same management. For booklets, address Mr. E. L. Gulick, 504 Addington Road, Brookline, Mass.





## Say, Boys! Come Hit a Real Wilderness Trail!

**H**ERE is a camp that is a real camp right in the thick timber of wilderness woods. No pretty study of wild flowers here. It's the woods, Boy. It's woods like your Great, Great Grand Dad chopped down for his house. It's woods like Daniel Boone trapped in. You're right bang up against Nature. You learn the woods' ways by playing the game straight. You make your own clearings. You build your own log cabins while you bunk in tents. You turn your own flap-jacks for breakfast. You make yourself comfortable by learning and doing all the tricks of the forester. You live like a guide and Oh Boy you live high!

And all the while you're right on the shore of Horseshoe Lake, one of the grandest mountain lakes in this great land. Of course, there is canoeing, fishing and swimming. There's also a real great clearing, level, making a complete athletic camp. All this is for rest and recreation. Our work in camp is learning by doing the things woodsmen have got to know—pitching our tents on hikes, cutting our own timber and building all the things that make life comfortable. Each fellow working for himself and the other fellows, yet strictly a vacation camp.

You go in to camp—The Wilderness Camp—on July the First. You're there in the heart of the Adirondacks on the sandy shore of Horseshoe Lake for two months. September First you come swinging out, a regular wood husky with all the tricks of doing things and a mighty good time to boot.

### If You Want To Come, Read This and Tell It To Dad

Is it safe? That's the question any real woodsman asks. No use taking unnecessary risks. Experts don't get wet or hungry. They keep fit. So do we. During the Winter we are a school of workers, of learners by being doers—we, of Raymond Riordon School. We have a full equipment for living safely and healthily in the woods at Wilderness Camp.

What kind of leaders? Not the kind of men who learn the woods from books, not the kind who get their own vacation by playing at being camp coun-

cellors. The men we use make an all-year-round business out of the woods. They're the finest, straightest of guides and expert foresters.

What's the cost? Only \$200 for the whole two months. Mighty little!

How do you get there? By the Adirondack Division of the New York Central Railroad from Utica or by automobile over State Road via Long Lake—the easiest way to deep forests in high, clear, healthy Adirondacks.

*Ask Dad to write for full information. Don't just sit idle yourself. This is a camp for fellows who do things for themselves. Write yourself.*

### The Wilderness Camp at Horseshoe Lake, Adirondacks, of the **RAYMOND RIORDON SCHOOL**

*(As Different a School as This Camp is Different)*

Address Inquiries to Raymond Riordon, Highland, Ulster County, New York

## Summer Camps for Boys—Continued

Trip Camp for Senior Boys  
14 to 16 years

# WINONA

Two Camps for Junior Boys  
8 to 13 years



A Summer in the Maine Woods for campers who like days in the open with tent and canoe, paddle and knapsack, glowing campfire, sizzling bacon, fishing in stream and lake, exploring mountain crag and deep ravine, and

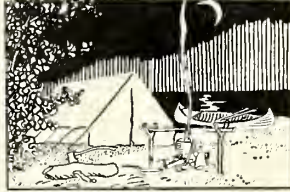

who enjoy the comradeship of home encampments with swims and horses, games and contests, sails and shells, keen rivalry on land and water, learning the ways of the great outdoors with men who know them.

C. E. COBB, Director, Denmark, Maine

For illustrated booklet, address C. E. Cobb, Director, Denmark, Maine.



## LENAPE

*The Pennsylvania Camp for Boys*

An ideal camp on crystal clear Lake Arthur in the heart of the Poconos. Conveniently reached. Group limited. **Splendid equipment.** Every activity, athletics, swimming, aquaplaning, boating, hikes, woodcraft, auto trips, etc. **Horseback riding.** Resident physician. Experienced councillors. Junior and Senior Camps. Associated with the Oneka Camp for Girls. Write for booklet.

ERNEST W. SIPLE

350 West Duval St. Box B, Germantown, Phila., Pa.

MARYLAND, Port Deposit.

## THE TOME CAMP FOR BOYS

On the Heights above the Susquehanna, near Port Deposit, Md. Every land and water sport. Hikes, Cruises, Tutoring. Senior and Junior Groups. Fine equipment. Christian Counselors. Head Counselor, John A. Tillema, University of Illinois. Rate \$225, July and August. Address,

JOHN A. TILLEMA, *Head Counselor* or  
MRS. I. T. BAGLEY, *Supervisor*, Port Deposit, Md.

## GREAT SUMMER VACATION

for younger boys. Swimming, Boating, Fishing, Camping, Hiking, Manual Training, Music, and as much school work under exceptional teachers as desired. The Woods and Lakes of Upper Ramapo Region, Orange County. Illustrated booklets.

MACKENZIE JUNIOR SCHOOL

Monroe, N. Y.

## CAMP TONKA'WA

BOYS 7 TO 15

"STICK TOGETHER"

An ideal spot for Junior boys on beautiful Lake Chautauqua, N. Y. 1500 Ft. elevation. One of the best equipped camps in the country. Horseback riding, hiking, swimming, athletics, tennis, fishing, boating, and manual training. Directed by matured men with high standards. Fun combined with all-around development.

Write for Booklet.

Rev. R. Carl Stoll

5 College Hill, Snyder, N. Y.



## Camp Navajo

*A Salt Water Camp for Boys*

on the rugged Maine Coast. Boating and swimming on Penobscot Bay. Hikes over the dunes and into the pine woods. Complete wireless outfit. Salt air offers healthful change to city and inland boys. Good food; weatherproof tents and bungalows. Mature supervisors; camp mother. Send for catalog.

ORRIN J. DICKEY, Belfast, Maine.

## CAMP PISCATAQUIS

Lobster Lake, Maine  
Eugene Hayden, Director

For boys 12-17. Offers a 250-mile canoe trip under famous guide from Lobster Lake to Fort Kent. Fishing, Hiking, Exploring. Your boy deserves the best. For booklet with map, write

H. J. STORER, *Secretary*, 74 Fayette Street, Cambridge, Mass.



Summer Camps for Boys—Continued

# Camp POK-O-MOONSHINE

*In the Adirondacks on Long Pond* For Boys 8-17

300 acres of woodland. Mountain climbing excursions to Ausable Chasm, White Face, Indian Pass, Lake Placid, Mt. Marcy. Boys divided into five separate groups according to ages. 35 mature college trained councilors. Charges include R. R. fares, trips, laundry and two hours of tutoring daily.

*One of the Oldest and Best*

**Address DR. C. A. ROBINSON, Principal**

17th Season. Box S5, Peekskill Military Academy, Peekskill, N. Y.



## Camp Winnecook for Boys

*Lake Winnecook, Unity, Maine*

20th Season. Athletic fields for all Sports. Horseback riding, canoeing, sailing, motor-cruising, Indian tribes, head-dress for deeds of valor. Indian pageant. Woodcraft, auto trips, hikes. Photography; Arts and Crafts. Tents and bungalows in pines. Every boy takes part in everything.

*One price—No extras. Send for booklet.*

Herbert L. Rand, 3 Hemenway Road, Salem, Mass.



## CAMP KATAHDIN

FOREST LAKE, SWEDEN, MAINE

Juniors Seniors Trips Athletic Conditioning

*For Boys and Young Men*

A camp with 22 years of **splendid traditions**. Appointments of camp, simple. Real camp life. Health conditions exceptional. Activities include real mountain and canoe trips, all branches land and water sports, horseback riding, woodcraft, nature study, tutoring.

Special athletic training season continues to September fourteenth.

Number limited. References required. Send for booklet, giving age and pertinent facts.

George E. Pike, B.S.  
Ralph K. Bearce, A.M.  
Duxbury, Mass.



## MIAMI CAMP FOR BOYS

In the woods on the banks of the Big Miami. Healthful, body- and mind-building recreation. Hiking, boating, fishing, swimming and athletic games. Lectures and entertainments around the camp fire. The camp attends the Miami Valley Chautauqua, hearing great preachers, statesmen, scientists, lecturers, musicians and entertainers. Many historic and prehistoric places of interest within easy hiking distance. For booklet, address

COL. ORVON GRAFF BROWN, Germantown, Ohio  
Under direction of Miami Military Institute

NEW YORK, Catskill Mountains.

**KYLE CAMP** for boys, 6 to 16. Catskill Mts. Model bungalows—no damp tents. Fine bathing. Your boy's health and diversion well looked after. Movies. Modern equipments. Physician; nurse; scoutmasters; "The paradise for boys."  
Address Dr. PAUL KYLE, Kyle School for Boys, Irvington-on-Hudson, Box 506.

## CAMP MADISON for BOYS

Will Accommodate 100

Madison, N. H. In the Heart of the Mountains.

For Booklet and Information, write

H. E. CUNNINGHAM, 34 School Street, Room 48, BOSTON, MASS.  
Residence, 3 Freeman Street, Arlington, Mass.

# Camp Wachusett FOR BOYS



Lake Asquam, Holderness, N. H.

20th Season. 7 Buildings. Boating, fishing, canoeing, swimming. New athletic field. Sports are planned according to physical ability of each boy. No tents. FISHER huts. Music, games and a good time every night. Camp contests. Tutoring if desired. References. Write for booklet.

REV. LORIN WEBSTER, L.H.D.  
Holderness School,  
Plymouth, N. H.



# CAMP YUKON for Boys

Winthrop, Maine

This Camp guarantees that your boy will have proper supervision, including medical care and matron's attention; that he will have good and sufficient food. Sanitary conditions, modern equipment for land and water sports complete, including horseback and golf. The location is in a grove at Lake Conhossecontee's shore, near good tarvia roads and four miles from the railroad. Choice of tents or hangarows. New large Main Hall furnishes plenty of space for dining, indoor recreation and shelter from stormy conditions. 9th Season.  
Frank D. Smith, 353 East 163 St., N. Y., Melrose 3370



# KAMP KILL KARE

The camp of happy times for clean boys. All the outdoor and indoor sports that a well regulated camp should have. Here there is play and diversion that mean well spent days for live American boys. An illustrated booklet on request.

R. F. PERRY, Principal  
Box M  
Morristown High School  
Morristown, N. J.

# T. I. P. CAMPS

for Boys 8 to 18 years

Thousand Islands Park Camps, where boys have the time of their lives. Swimming, fishing, horseback riding, canoe building, etc. In beautiful St. Lawrence River. Separate camps for Juniors and Seniors. Rate, all inclusive, \$300. Address

WALTER C. CROUCH  
Friends Central School, Phila., Pa.



# BLACKWATER CAMP

Cody, Wyoming

An all-year Camp in the Rocky Mts. for boys 8 years old and up. Hunting, fishing, riding and camping trips with saddle and Indian "Cayuses," into the best big game sections of Wyoming. Real life in a Man's Country!

Folder on request

BRONSON C. RUMSEY



# CAMP TY-GLYN

A CAMP FOR BOYS 7 to 17  
MOWN LAKE, ROOSEVELT, WIS.

Horseback riding, tennis, canoe trips with guides, swimming, baseball, basket-ball, manual training, wireless telegraphy. All counselors college men, each one a specialist. Tuition \$260.00; no extras. For booklet, write to  
G. A. ROGER, 700 W. Euclid Avenue, Detroit, Michigan.

# BEAR MOUNTAIN CAMP

FOR BOYS  
HARRISON, MAINE

In the pines, on the sandy shores of Bear Lake. Wonderful food, swimming, diving, fishing, camping and canoe trips, boxing, target practice, tennis, baseball, soccer, campfire stories, mountain climbing. A gloriously happy and healthful summer is offered by this ideal camp. Ages 7 to 17, tuition \$275.00 for eight weeks. Illustrated booklet S.

HAROLD J. STAPLES, Director

Biddeford, Maine

9th Year **CAMP** For Boys 7-15 ON OTSEGO LAKE COOPERSTOWN, N. Y.  
**CHENANGO** A Camp that grows thru its enthusiastic boys

Only six hours from New York City

A parent writes: "My son returned home in splendid physical condition, much improved by reason of his summer outing. He tells us very enthusiastic stories of the good treatment and care which he received." All sports. Horseback riding. Write for book: E. L. FISHER, 24 N. Terrace, Maplewood, N. J.



## Summer Camps for Boys — Continued



### DAN BEARD WOODCRAFT CAMP

To be a Woodcrafter in personal touch with the real Dan Beard is a rare privilege. Are you going to be one of them? Membership limited. In charge of the famous scout himself. On beautiful Pennsylvania mountain lake. All the outdoor activities that boys like. Sound physical, mental and moral training. No extra charge for tutoring. Specially endorsed by ex-President Roosevelt.

Apply 89 Bowne Avenue, Flushing, L. I., N. Y.



### Camp Kineo

On Long Lake, Harrison, Maine

See Kineo Advertisement in the February St. Nicholas

For boys 7 to 15 inclusive who can afford to pay a fair price for exceptional advantages. Kineo's wide range of activities is in charge of mature men. Sports and hobbies every virile boy loves—all at their best. Horsemanship, swimming, water sports in variety. Mountain trips, ocean cruises, handiwork in wood and metal; electricity, auto and motorboat schools. Radiotelephone. Wireless school. Safeguards everywhere. Camp comforts. Safe comradeship. State age. Address



Irving N. McColl, Hotel McAlpin, New York City



### CAMP MASSAWEPIE

In the Adirondacks

Wonderful location in the virgin forests on the shores of Lake Massawepie. Splendid equipment, handsome buildings, club house, bowling alleys, baseball and tennis grounds. Fine sand beaches, good fishing, swimming, athletic sports. Tutoring, forestry, woodcraft. All activities under careful supervision. Season, July and August. For information, apply to

LT. COL. GUIDO F. VERBECK Box S. 5. Manlius, N. Y.

MASSACHUSETTS, West Harwich, South Shore, Cape Cod.

**CAMP MON-O-MOY** For Boys. Modern equipment; managed by experienced educators; camp mother; magnificent beach; superb swimming; sailing; canoeing; deep sea fishing; baseball, basket-ball, tennis. Expert tutoring. Illustrated booklet.

HARRIMAN R. DODD, Executive Officer,  
Worcester Academy, Worcester, Mass.

PENNSYLVANIA, Montoursville.

### CAMP LOYALSOCK for Boys

In the heart of the Lycoming County hills, an exceptional camp with an exceptional fee, \$100.00. All land and water sports under trained leaders. Best food. L. E. KLEPPER, Monument and Belmont Roads, West Park, Philadelphia.

### This is the 29th year of CAMP CHAMPLAIN FOR BOYS 7 to 16

On Mallett's Bay, Lake Champlain  
Between the Green and Adirondack Mountains

Up early in the morning after all night in a tent—pine laden air—dash into lake—hearty breakfast and off for the day's sports. Out all day fishing, rowing, swimming, or land sports all under experienced men. Booklet.

WM. H. BROWN, President Berkeley-Irving School  
307 West 83rd Street New York City



28th Year  
BOYS 7-16

On the  
Trail to  
Whiteface  
Mt.



### CAMP NORRIDGEWOCK

For Boys

Oakland, Maine

Offers to the boy the best that there is in camping. Three pine-covered islands of seventy-five acres on East Lake, one of the famous Belgrade Lakes. Canoe trips, fishing, tennis, baseball, swimming, football and tutoring. Modern sleeping bungalows. Experienced leadership. Camp mother. Boys eight to eighteen years.

May we send you an illustrated booklet?

ARTHUR M. CONDON - Northampton, Mass.

MAINE, East Brownfield.

### SAKUKIAK CAMP

For boys from ten to fifteen.

In personal charge of an experienced physician. Situated in the eastern foot-hills of the White Mountains, one mile from a trunk rail line. Swimming, athletic field, mountain climbing. Booklet on request.

WHITMAN G. STICKNEY, M.D., Beverly, Mass.

PENNSYLVANIA, Mehoopany.

**CAMP FERN** Admits boys 8 to 16 years old. Located at Mehoopany, in the Allegheny mountains of eastern Pennsylvania. Excellent climate. All sports. Tutoring free. Minimum rates. Until June 10th, address B. M. SLATER, Box 82, Long Valley, N. J. After June 10th, address CAMP FERN, Mehoopany, Pa.

CONNECTICUT, On Bantam Lake.

### SAGAWATHA LODGE

100 miles from New York City. Cabin Camp for 40 Boys. Ideal spot. Land and water sports. Athletic field, Underground Shooting-Range, Hiking and Canoeing. Camp mother, experienced Counsellors. For booklet or interview. DR. J. H. HOBBS, To April 15, Hotel Albert, N. Y. City. After, Lakeside, Litchfield Co., Conn.

## Summer Camps for Boys—Continued

### CAMP NOKOMIS

*In the heart of the  
camp region*

#### HARRISON, MAINE



A completely equipped camp for BOYS, on Long Lake, modern in every way. Exceptional staff of counsellors, facilities for every kind of sport, every possible safeguard, tents and bungalows, trips, food of the finest kind and plenty of it. We have a remarkable record for continuous enrollments—the camp satisfies.

Membership limited to 45—enroll early

Illustrated booklet on request

**ROY E. ADAMS**

11 Marlborough Rd. Philadelphia, Pa.

### Pole Bridge Camp

Matamoras, Pike County, Penn.

Boys  
8-14

A wonderful camp on a mountain top in the Water Gap region overlooking the Delaware, only 90 miles from New York. Mountain, water, and indoor sports. Buildings, tents, equipment up-to-date. 25 Boys, 6 Yale counsellors, parental care and big brother inspiration. Illustrated booklet and references.

**E. HOYT PALMER, Manager**  
75 Yale Sta., New Haven, Conn.



### Camp We-e-yah-yah

*Among the Thousand Islands  
St. Lawrence River*

Boys  
8-17



**FIFTY BOYS**, 8-17 years, will have their biggest summer full of fun and healthful recreation. All land and water sports, Boating, Canoeing, Swimming, Fishing, Tennis, Baseball, Basket and Volley Ball, Track Athletics, Rifle Practice, Golf and Horseback riding are our special sports. Camping out trips. Expert counselor supervision. Everything the best. Your son will be bigger and better mentally, morally and physically. \$275 For the summer. *Send for Illustrated Booklet.*

**HARRISON H. BUXTON (A Rotarian)**  
904 Newell St. Utica, N. Y.

### Camp Terra Alta

Terra Alta, W. Va.

6th Season

Directed by **COMMANDANT of the STAUNTON MILITARY ACADEMY**

On Lake Terra Alta, main line B. & O. R.R., 130 miles southeast of Pittsburgh. 2800 ft. above sea level.

Average summer temperature 70 degrees.

\$20,000 Equipment. Athletic and water sports, bowling, billiards, hikes—all under strict supervision.

Physical drill and target practice.

Academic instruction, Music.

June 29 to August 24, \$200. Free booklet.

Until June 5th address The Commandant, Box 451F, Staunton, Va.

After June 5th, Camp Terra Alta, Terra Alta, W. Va.

11th Year

### CAMP RED CLOUD

For Boys 8 to 18

*On Silver Lake*

Susquehanna County  
(P. O. Brackney), Pa.

1800 feet above sea level in original pine forest. Equipment complete—Horseback riding, canoeing, swimming, track and field athletics. Wireless telegraphy and telephony, photography, shop work, dramatics. Experienced physician. Trained nurse—complete infirmary. Food unexcelled. Tutoring school conducted by successful teachers. Illustrated catalogue.

**DIRECTORS** { **MAJOR LOUIS E. LAMBOEN, Principal's Assistant,**  
**EDWARD C. WILSON, Principal.**  
FRIENDS SCHOOL, Baltimore, Md.

### MITIGWA CAMP

Dodge Pond - - - Rangeley, Maine



Where forest trails and waters are waiting.

Canoe and mountain trips with guides.

Water sports and athletics with leaders who know how. The membership is limited.

A booklet on request.

J. W. Fairchild, Jr., 48 Grove Street, Pawtucket, R. I.



### CAMP KINAPIK

*The Woodcraft Camp for Boys from 8 to 16*

ON LAKE KEZAR, MAINE

Come to the lakes, woods and rivers of Maine; the White Mountains of New Hampshire. Swimming, Fishing, Council fires. Secrets of camp and woods. Mountain trips and camps. Canoe trips near and far. Wilderness and special trips for older boys. Age groups. Particular supervision. Resident physician. Camp mother. Endorsed by Ernest Thompson Seton. For illustrated booklet, address

**HARVEY C. WENT, Director, Bridgeport, Conn.**

### Come to MINNE-WAWA

*Permanent Summer Camp for Boys and  
Young Men*

Fun, fun, FUN—fishing, canoeing, swimming, tramping—at Camp Minne-Wawa Lake of Two Rivers, Algonquin Provincial Park, in heart of Ontario Highlands. Wholesome moral atmosphere. Plenty of good food. Highest references. Reasonable terms. Write **W. L. WISE, Ph.B., Bordentown, N. J., for Booklet D.**

### BOB-WHITE FOR BOYS under 15

SENIOR & JUNIOR DIVISIONS



NINE WEEKS of long Horseback Rides through woodland trails. Hikes and Gypsy trips from lake to lake. Swimming and Boating. Shopwork and Boat-Building. Good stories around the Camp Fire. All the fun of camp and farm life combined.

**Ralph C. Hill, Mrs. Sara B. Hayes, Ashland, Mass.**



## Summer Camps for Boys—Continued

# ROTHERWOOD

## BOYS—

### Hurrah for the Maine Woods!

You never will enjoy real camp life at its best until you swim in the clear Maine lakes, canoe up the wonderful streams, hike through the deer-tracked forests and sleep under the enormous pines. At Rotherwood Camp there are such glorious days for boys! Such wonderful sports and fine eats! Mother and father will be glad to have you go to Rotherwood—it's just the place they would pick out, with fine boys for chums and everything the best. Write us for our booklet "B."

**CAMP ROTHERWOOD - Alfred, Maine**

# CAMP PENACOOK

North Sutton, N. H. Twenty-fourth Season  
 Limited number of desirable boys, ages 9 to 16.  
 All field and water sports. Experienced counselors. Exceptional equipment. Wholesome food.  
 Rate \$250 R. B. MATTERN, M.S.  
 Dobbs Ferry-on-Hudson New York

New York, Woodland.

### CAMP WAKE ROBIN

Younger boys exclusively. Eighteenth season. Make your boy strong, happy, through an out-of-door life, including woodcraft, hiking, nature-lore, manual training, swimming, and all sports. Matured supervision and modern sanitation. Booklet.  
 Mr. H. N. LITTLE, New Jersey, Jersey City Lincoln High School.

NEW HAMPSHIRE, on Lake Ossipee.

### CAMP OSS�PEE

FOR BOYS UNDER 15

19th Season on Lake Ossipee in White Mts. (125 Miles from Boston.) Horses, Canoe trips; Ideal Swimming and Fishing; Science, Music, etc. *Expenses moderate—Conducted like a Club* by the Headmaster of one of the oldest and best-known private schools. For circular, address  
 O. E. GUILD, Secretary,  
 Nassau Place, Peekskill, N. Y.

## CAMP PINNACLE

LYME, NEW HAMPSHIRE

A real boys' camp; established reputation. Rate \$200. Limited number desirable boys 8-15 years. All field and water sports, wireless, horseback riding; all other camp activities. Only experienced councillors. Wholesome food carefully supervised. Send for illustrated booklet.

Mr. and Mrs. Alvin D. Thayer, 6 Homestead, Longmeadow, Mass.

## PEQUAWKET CAMPS

IN THE WHITE MOUNTAINS

A Camp of Character and Ideals for 50 boys from 8 to 18  
 Scouteraft, Woodcraft, Mountain Climbing, Hiking, Field Athletics, Tennis, Baseball, Horseback Riding, Canoeing, Motor-Boating. All Water Sports. Private Pond. Wooded Shores. Sandy Beach.

Table unexcelled for variety and abundance.

For beautifully illustrated booklet, telling not only about the camp but also about the men and personalities who control it, address the directors

MR. and MRS. EUGENE I. SMITH - Conway, N. H.

### The Muscle-Developing Giant Stride



### KAMP KUN-JA-MUK for BOYS

7 to 18 years of age. Non-Sectarian. On Lake Pleasant, designated by the 1921 Automobile Blue Book as the "Pearl of the Adirondack Lakes." Extensive equipment in every respect. Moving pictures, baseball, basket-ball, football, tennis, rowing, canoeing, swimming, diving, shoot-the-chutes, and all other land and water sports. 8th year. Well-known companionable college-bred counselors. Every former camper and parent highly satisfied. Doctor and nurse. Numbers are limited. Mention references in replying. References gladly exchanged. Fee, all inclusive, \$325. Booklet. 33 Vernon Ave., Brooklyn, N.Y.

### St. Lawrence Cruising Camp for Boys

Cruising on large powerful yacht—camping on shore—inland trip. Hudson River, Lake Champlain, St. Lawrence and Saguenay Rivers. Visiting Montreal and Quebec. Complete equipment, excellent food, experienced leaders, perfect safety. Boys 10-16. Moderate rate. Leave New York July 1st—return September 2nd. Booklet.  
 Box 242, Sewaren, New Jersey.

CONNECTICUT, Bantam Lake.

### CAMP WONPOSET

A camp for young boys in the Berkshires, 100 Miles from New York City. Everything a boy can wish for. Write for camp book.  
 ROBERT TINDALE, 31 East 71st St., New York City.

WISCONSIN, Fish Creek.

### CAMP WILDWOOD

For Boys. Write for catalogue.

Mr. and Mrs. W. B. BIRD,  
 3273 Berkshire Road,  
 Cleveland Heights, Ohio.

## Camp Kokosing

For Boys

On Lake Kokosing

Orange County

Vermont



Camp of several hundred acres on beautiful 100-acre private lake. Hikes along trails of White and Green Mts. Canoe trips on Connecticut River. All land and water sports. Member W. J. R. C. Tutoring, Counselors of finest calibre. Special oversight by camp mother for youngest boys. Rate, \$225 for season. No extras. Illustrated booklet on request.

EDMUND C. COOK, A.M., St. Stephen's College  
 Annandale-on-Hudson, N. Y.

# CAMP MONADNOCK

Jaffrey, N.H.

Ninth Season

**SENIORS**  
12-16



**JUNIORS**  
8-12

A character-building camp. Feel camp life in the exhilarating air of the mountains. Elevation 1200 ft. All equipment and buildings especially planned for camp purposes. Carefully selected boys in the personal care of experienced men. All sports—land and water—that appeal to a red-blooded boy. Unique combination of individual development thru instruction in nature subjects, scouting, handcrafts, and athletics. 3 hours from Boston

*Write for booklet and letters*

**FREDERICK S. ERNST** (Harvard A.B.), Director, 15 Babcock St., Brookline, Mass.



HELLO, BOYS, won't you go fishing with me and my three brothers, at my Dad's camp this summer? It is

## WAWBEWAWA

The Canoeing Camp for Boys  
On Squam Lake at Ashland, N. H.

We'll go on lots of canoe trips and camping-out trips, instead of just loafing around camp and playing games. We'll learn how to follow a trail through the woods and up mountains; to build a cooking fire and mix a "twist" and toss "happ-jacks"; to paddle a canoe for fishing and cruising and racing and "stunts"; to make a browse bed and sleep rolled up in a blanket under the stars; and we'll know how to

hold up our heads and look the other fellows in the eye.



Don't forget Dad's address is

**DR. JOHN B. MAY**, Director, Cohasset, Mass.



## CAMP WAMPANOAG

16th Season Cape Cod, Buzzards Bay

A salt water camp for boys from 8 to 16. Scouting over old Indian trails. Land and water sports, prizes. Athletics under experienced college men. Instruction in life saving. Military drill. Camp mother. Booklet.

MRS. BERTRAND E. TAYLOR, Director  
MR. ALDRICH TAYLOR, Advisory Director

240 Grant Avenue Newton Centre, Mass.

## CAMP CONTOCOOK

East Jaffrey, N. H.

Featuring golf, a new attraction for Summer Camps, also bowling, athletics, mountain climbing, hikes, and water sports.

*For booklet, address*

**FRANK W. MOSES**, Carnegie Institute of Technology, Pittsburgh, Pa.

**LESLIE WOOD**, Manual Training H. S. or  
333 St. John's Place, Brooklyn, N. Y.

## OCEAN CAMP

*For boys 8 to 17*

On beautiful, historic, secluded Flying Point, twenty miles from Portland on Maine coast in heart of historic section. Seventy acres of beautiful pine and balsam-fir forest and open field. Best peeled log camps in Maine. Large fireplace, screened dining porch. All land and water sports. We use safe flat-bottomed row boats. Boys always accompanied by at least one counselor who is an expert swimmer. No canoes, no smoking. For booklet, address

**ERNEST E. NOBLE**, Portland, Maine

## THE TOLTEC CLUB

### 'A Summer Camp

FOR BOYS

In the Connecticut Hills

The unique feature of the camp is the camping tours throughout the New England states in the course of which many spots of historical and other interest are visited, mountains climbed and all sorts of adventures encountered. A splendid opportunity for boys. All kinds of athletic sports, swimming, boating, etc. Membership limited. For booklet, address:

**THE DIRECTOR**, 81 Jane St., New York

RHODE ISLAND, Hopkinton.

**Camp Mary Elizabeth** among the pines. Fishing, boating, bathing and all outdoor sports. Direction of competent scout-masters and camp mother. Graduate registered nurse. New York City. July—August, \$200. For particulars call Audubon 2552. Address Mrs. Mary E. Mather Cochran, R. N., 185 9th Ave., N. Y. C. Care of Mr. Thomas Rowland



# CAMP PASSUMPSIC

*Lake Fairlee, Vermont*

The Ideal Camp for Young Boys where the Aim is Health and Happiness.

*Illustrated Booklet on Request.*

WILLIAM W. CLENDENIN, A.M. 120 Vista Place, MT. VERNON, N.Y.



## CAMPS Information

FREE catalogs and advice of experts on ALL Boys' or Girls' camps (also private schools) in U. S. Relative standing from personal inspection. Maintained by the schools. **No Fees.**

Call, write, or phone  
Bryant 8980

AMERICAN SCHOOLS ASSOCIATION

Times Bldg., New York or  
Masonic Temple, Chicago

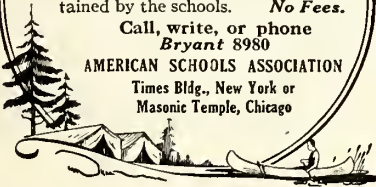

Adventure  
Navigation  
Yacht Racing  
Deep Sea Fishing  
Newport  
Marblehead  
Nantucket

## Cruise OF Vespa

Magnificent ocean going, 70-foot, auxiliary schooner, New York to Bar Harbor, Maine and return (1200 miles), stopping for two or more days at many of the famous summer resorts. All land and water sports, sight-seeing, receptions, etc. Small boat races, swimming races, etc. Two cruises—one in July and one in August, for boys 14 to 19 years of age. For full particulars apply to  
**B. HOLT WILLARD, 8 Bridge St., New York City**

## SCHOOL SERVICE for St. Nicholas Readers

This department is maintained for the benefit of our readers. It helps parents in the selection of the proper schools for their sons and daughters, always remaining conscious of the particular needs of each pupil.

If you are perplexed and do not know which school to choose, we will gladly advise you without charge.

*Give as much information as possible when writing. Address*

SCHOOL SERVICE DEPARTMENT

**THE CENTURY CO.**

353 Fourth Avenue

New York City

## Summer Camps for Boys and Girls

**CAMP FIRE ISLAND** (Long Island, N.Y.) Ideal Summer Camp for Boys and Girls (reservations for  
**OCEAN AND BAY** grown-ups.) Rates: season, \$20.00 weekly; shorter periods,  
\$25.00, including excellent board. Surf and bay bathing, fishing, boating and other activities. Railroad fare \$1.01 from New  
York. For booklet, write OCEAN BAY CO., 111 West 42nd Street, New York. Phone Bryant 6280.



### KENTHOPE

West Chester - Pennsylvania

A summer home with mother care for little folks, 5-12. Twenty-five miles from Philadelphia. Simple, farm-home life and activities. High location, fresh eggs, vegetables, tuberculin tested milk, outdoor sleeping if preferred. Trained nurse. Free riding, tennis, ample playgrounds, swimming, live pets. Supervised play and sports. Crafts. Special tutoring if desired. Opens May first. As the children are limited to a small number, early reservations are advisable. Address

MRS. ANNE KAY HUMPHREY

West Chester - Pennsylvania

ILLINOIS, St. Charles.

### ORCHARD HILL CAMPS

on the beautiful Fox River, forty miles west of Chicago. Companion camps for boys and girls from three to fourteen. Boys camp directed by Dr. Richard J. Lambert assisted by experienced scout master. Girls camp under the personal direction of Dr. Edith B. Lowry. Write ORCHARD HILL CAMPS, St. Charles, Ill.

### BOYS!

Did you ever see such a fine display of camp advertisements as those on the preceding pages? We feel sure that you will find a camp there suited to your wishes, whether it be in the wilds of Canada or in the heart of the Rockies.

*For further information address*

The Camp Service Bureau of  
ST. NICHOLAS MAGAZINE

353 Fourth Avenue New York City



## Joseph B. Ames

*has written a*

cracklingly eventful  
exciting, colorful

readable

*Novel of Ranch Life in Our Southwest*

## SHOE-BAR STRATTON

IT HAS a plot that wins interest right from the start and then never lets it wander for one moment until the always satisfactory and in this case artistically inevitable "happy ever after" of the last pages. It has healthy, warm-pulsing adventurousness; the struggles of strong men; the plucky, courageous tenderness of a fine woman. It has the thrill, the vigor and the "punch" that belongs to all outdoors. It was written for its readers to enjoy, and you will enjoy it.

**Price, \$1.75**

**THE CENTURY CO.**

353 Fourth Avenue, New York City



# GOOD SCHOOLS

FOR  
BOYS *and* GIRLS



## The Castle

Junior Department of Miss Mason's School

For the little girl who wants a school like older sisters. Work and play directed for the steady development of the child from 6-12 years of age. Unsurpassed advantages. Near New York City. Rate \$1000. Catalog.

Miss C. E. MASON, *Principal*  
Box 725, Tarrytown-on-Hudson, N. Y.



## Lincoln School

A school for girls, offering country life with the advantages of the city. Preparation for college examinations, and general courses. Exceptional opportunity for outdoor sports. Horseback riding.

Miss Mariam Sewall Converse, *Principal*  
Providence, Rhode Island

PENNSYLVANIA, Rydal, Montgomery County.

**RYDAL** The Junior Department of the Ogontz School. A Home School for Girls 9 to 14. A teacher of strong personality, who has had unusual success in training little girls, is in charge. Enrollment is limited. Write for catalog.

MISS ABBY A. SUTHERLAND.

NEW JERSEY, Orange.

## MISS BEARD'S SCHOOL FOR GIRLS

A country school, 13 miles from New York. College preparatory, special courses, Music, Art, Domestic Science. Supervised physical work in gymnasium and field. Catalog on request.

LUCIE C. BEARD, *Headmistress*.



## Southfield Point Hall

A School for Girls. Beautifully situated on Long Island Sound at Southfield Point. Intermediate, general, and college preparatory courses. Music, gymnastics, athletics, and sports. Horseback riding, skating, Skiing. 52 Minutes from Grand Central Station, New York. Limited enrollment.

JESSIE CALLAM GRAY, B.A., *Principal*

BERNICE TOWNSEND PORTER, *Assistant Principal*

10 Davenport Drive, Stamford, Conn.



RHODE ISLAND, Providence.

## THE MARY C. WHEELER SCHOOL

*A Town and Country School for Girls*

College preparatory and General Course. Advanced Studio classes. Music. Secretarial Course. Farm Home for girls 10 to 14 years.

MASSACHUSETTS, Northampton.

## WILLISTON JUNIOR SCHOOL

For Young Boys. Organized to develop the entire boy. Thorough work and graded athletics. The Senior School prepares for all leading colleges and scientific schools.

ARCHIBALD V. GALBRAITH, *Principal*, Box N, Easthampton, Mass.



## Stamford Military Academy

A preparatory school that pursues sound educational methods and provides a thorough training for mind and body. Located in the beautiful hill country of Connecticut, convenient to New York, the situation is ideal. Classes are purposely small and students are assured individual consideration from every teacher. The locality permits every kind of outdoor sport and the gymnasium is well equipped for all indoor exercise. Summer Camp. For catalog, address **WALTER D. GERKEN, A.M., Principal**  
New Canaan, Connecticut

## Woodland Park

### Junior School for Lasell Seminary

Prepares for Lasell Seminary and other leading secondary schools. Careful direction under House Mother. Progressive methods of study and play. All the equipment of Lasell Seminary, with playgrounds, gymnasium and swimming pool. 15 Buildings. 30 Acres.

Camp Teconnet opens July 1.

**Guy M. Winslow, Ph.D.,**  
Principal. **Chas. F. Towne,**  
A. M., Associate Principal.  
Woodland Road, Auburndale,  
Mass.



# Powder Point School

will understand your boy—and help him to understand himself. Thorough instruction. Clean, snappy athletics for every boy. Clearest understanding between boys and masters. Prepares for college and gives strong general courses. Ages 10 to 19. Number limited to sixty. Convenient to Boston. Address Headmaster,

27 KING CAESAR ROAD, DUXBURY, MASS.

# BINGHAM SCHOOL, MEBANE, N. C.

ESTABLISHED 1793

AN IDEAL BOYS SCHOOL IN PIEDMONT, NORTH CAROLINA

HERE, at Bingham, the spirit of old-time Southern hospitality makes each boy feel genuinely welcomed. Military organization, begun in 1861. High moral tone. Lovely lawns. Gymnasium. Athletic park. Honor System. Celebrated climate. Outdoor classes. Limited numbers. Sports in variety. 340 acres. Summer camp. A modern school with an ancient name, fame and history. Send for catalogue.

COL. PRESTON LEWIS GRAY, *President*, Box 8, Mebane, N. C.

## Miss Hall's

SCHOOL FOR GIRLS

In the Berkshire Hills, on the Holmes Road to Lenox. Forty-five acres. One thousand feet above the sea level.

Miss **MIRA H. HALL**, *Principal*  
Pittsfield, Massachusetts

MASSACHUSETTS, Berkshire.

**CRESTALBAN** A school for little girls in the invigorating climate of the Berkshires. Thirty minutes from Pittsfield. 200 acres, 3 buildings. Number limited. Special care given to home training, character development, and health. Open-air classes. Outdoor sports. **MISS MARGERY WHITING**, *Principal*.

PENNSYLVANIA, Swarthmore.

**THE MARY LYON SCHOOL** A Country School in a College Town. Preparatory for college. High scholastic standards. Music, Art, Languages, Home-making Sciences. Outdoor sports including canoeing. **SEVEN GABLES**—Junior School. **WILDCLIFF**—Graduate School. Write for catalogs. **MR. and MRS. H. M. CRIST**, *Principals*,  
Box 1542, Swarthmore, Pa.

MARYLAND, Baltimore.

## THE ROBERTS-BEACH SCHOOL

Offers a strong college preparatory course for girls. Limited numbers with close individual instruction. Attractive home in beautiful suburban Baltimore. Catalog. Address Box 900, Catonsville, Md.

CONNECTICUT, Cornwall.

## RUMSEY HALL

A School for Boys under 15. Yearly rate \$1200.

**L. R. SANFORD**, *Principal*.

**LOUIS H. SCHUTTE, M.A.**, *Headmaster*.

# Whiting Hall

## A Country Home School for Girls

from eight to sixteen, affiliated with the best preparatory schools. Twenty-six acres, modern buildings, new gymnasium, ideal location, high elevation—halfway between Boston and Worcester, near Longfellow's Wayside Inn. Outdoor sleeping and class rooms, if desired. Individual care. Teachers for all branches. Mistress of field games. House mother. Family life emphasized. Tenth year.

**MR. ELBRIDGE C. WHITING**, Amherst, Yale, **MRS. WHITING**, Wellesley, Prins.  
12 CONCORD ROAD, SOUTH SUDBURY, MASS.





# TENACRE

*A Country School for Young Girls from Ten to Fourteen Years of Age*



*Riding Class at TENACRE*

**P**REPARATORY to Dana Hall. Fourteen miles from Boston. All sports and athletics supervised and adapted to the age of the pupil. The finest instruction, care and influence.

MISS HELEN TEMPLE COOKE  
Dana Hall, Wellesley, Mass.

## PAGE MILITARY ACADEMY

*A Big School for Little Boys*

A school whose military system is modified to meet the needs of growing boys. Thoroughness in primary and grammar grade work goes hand in hand with military training to inculcate orderliness, promptitude and obedience. Page will give your boy the right start toward earnest, successful manhood. The high, healthful location between city and ocean affords a beautiful home in a matchless climate.

You should have the latest Page catalog. Address

ROBERT A. GIBBS, Headmaster  
Route 7, Box 947  
LOS ANGELES CALIFORNIA



250 Alert Boys      22 Competent Men  
\$800,000 Equipment  
89th year opens September 19th

## WORCESTER ACADEMY

WORCESTER MASSACHUSETTS

Rates: \$1000 single  
\$850 double

Junior School for young boys

For catalog address the Registrar, G. D. Church, M.A.

SAMUEL F. HOLMES, M.A., Principal

## The Hedges

NORTON, MASS.

The Junior School of House in the Pines. 30 miles from Boston. For girls under fourteen. A large modern home. Sun parlors for class rooms. Play fields. Horseback riding. Swimming. A wholesome, simple life of study and play that makes the child quick to feel, eager to know, able to do.

MISS GERTRUDE E. CORNISH, Principal



## Junior Bradford

Prepares for Bradford Academy, having the benefits of its splendid equipment, intellectual and social activities, and athletic grounds. Gymnasium. Swimming pool. Separate building. Girls from the fifth grammar grade up accepted. Healthful mental and physical development under especially trained instructors. Address

The Principal, Bradford, Mass.

MASSACHUSETTS, South Byfield, Mass.

## DUMMER ACADEMY

A preparatory school for a limited number of selected boys. Ideal country location. Moderate fees. International reputation. 160th Year opens September 19.

NEW YORK, Ossining-on-Hudson.

## OSSINING SCHOOL

For Girls. 54th Year. 30 Miles from New York. Academic and economic courses. Separate school for very young girls. For catalog, address  
CLARA C. FULLER, Principal. Box 5 N.

## The St. Nicholas School and Camp Service Bureau

is maintained for the purpose of assisting the parents in selecting camps and schools for their children. We are well equipped to handle all inquiries and are anxious to render any other service possible.

For further particulars write

The School and Camp Service Bureau

ST. NICHOLAS MAGAZINE

353 Fourth Avenue

New York City

# “I’m Coming!”

It was a boy who said it as he let the flood force his shanty-boat through the jam to save the two lads on the wreckage; but it was a man in supremely tested courage and firm nerve who came out of the tremendous experiences told in



## DRIFTWOOD

By R. S. Spears

THE BEST STORY OF THE MISSISSIPPI SINCE  
“Huckleberry Finn”

A story for boys and girls of the Mississippi in flood. Full of thrilling adventure and plucky, resourceful, level-headed work of rescue. There is in it something that makes grown-up readers, too, appreciate and praise the book. It is a vivid picture of the river life and river-folk. And behind all the tense, exciting action is a movement that lifts it far above the average, that makes it at the same time an adventure story of the finest and an epic of mighty waters in irresistible flood. A remarkable juvenile; a notable American book; a book to own.

*Illustrated. Price \$2.00*

I  
WANT  
.....copies of

**DRIFTWOOD**

**THE CENTURY CO.**

353 Fourth Avenue

NEW YORK CITY

for which I enclose \$.....

Name.....

Address.....



A MAY-BASKET MELODY.

SO LOVELY, JOYFUL  
May! Month of flower-  
baskets gay; Merry youngsters  
nimble, fleet; Running fast  
in every street, Leaving  
baskets on the sills;  
Ringing doorbells;  
Oh, the thrills!  
Happy, joy-  
ous month  
of May! Wel-  
come! we say.

Margaret Wheeler Ross.



"HAPPY AND FLOWER-LADEN, THEY BRING THEIR FRAGRANT LOADS"  
(SEE PAGE 676)



# ST. NICHOLAS

VOL. XLIX

MAY, 1922

No. 7

Copyright, 1922, by THE CENTURY Co. All rights reserved.



## May-Day in Merry England

by  
Florence Boyce Davis

**W**

o! all of you whose forefathers have hailed  
from England's isle,  
Who have a drop of English blood a-coursing  
through your veins,  
And also you who have n't, but are ready  
with a smile,  
Come on with me and take a trip a-down  
the ancient lanes

And join the folk, the merry folk; with happy-hearted din,  
We'll make the welkin ring again and bring the May-pole in.

It is the sixteenth century; King Henry wears the crown;  
And spring is sweet upon the land, the bloom is on the bough;

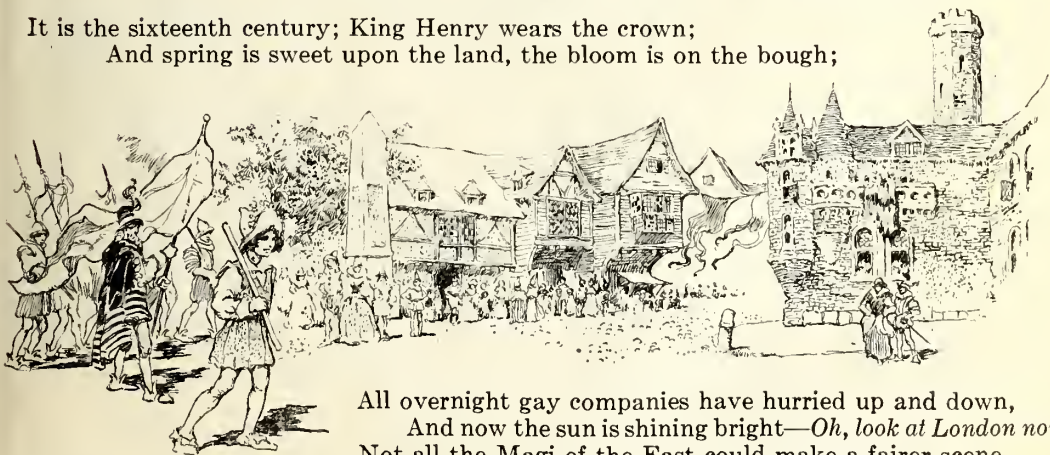

All overnight gay companies have hurried up and down,  
And now the sun is shining bright—*Oh, look at London now!*  
Not all the Magi of the East could make a fairer scene.  
The streets have turned to fairy parks, decked out in living green,

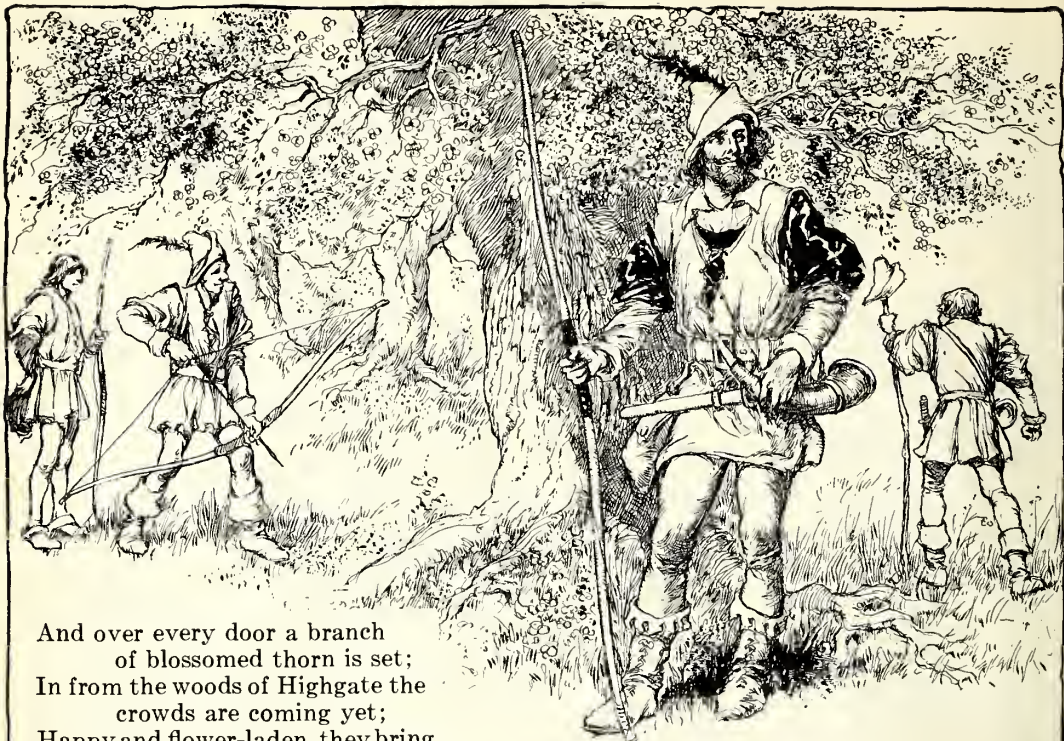

And over every door a branch  
of blossomed thorn is set;  
In from the woods of Highgate the  
crowds are coming yet;  
Happy and flower-laden, they bring  
their fragrant loads,

And song and laughter mingle along the friendly roads.  
And see! the king's among them— Hurrah! God save the king!

All clad in white and silver are his courtiers, every one.

To add to the festivities, behold the boughs they bring—

Green boughs but freshly gathered from the woods of Kensington!

Now comes above the tumult the sound of pipe and drum,  
And all eyes turn expectant to see the May-pole come.  
To the lilt of merry singing and the sound of dancing feet,  
Majestically and slowly 't is drawn along the street  
By forty yoke of oxen, whom garlands gay adorn,  
A fragrant nosegay nodding from the tip of every horn!  
Ah, now the day's festivities in very truth begin;  
We've set the boughs, we've hailed the king, we've  
brought the May-pole in!



"Make ready with the mummers; let Robin Hood appear;  
Now start the morris-dances, for everybody's here.

Good-day to you, Maid Marian; we're glad you're  
back again!

Good-morrow to you, Robin Hood, and all your Merry Men!  
A jolly-looking lot you are, clad in your Lincoln Green;

There's Friar Tuck, the chaplain, and here comes  
Little John.

Now get to work, brave Robin Hood, and make a merry  
scene,

And show your skill in archery before the day be  
gone!"





Thus speaking one another, he travels up and down,  
The highest citizen of all, Lord Mayor of London Town.

Hour after hour the Queen of May within her arbor sits,  
Parceling out the favors that are won by ready wits,  
To youths who play at bucklers, and to merry dancing girls;

And past her vernal bower the gay sight-seers fare—  
Ladies robed in cloth-of-gold embroidered o'er with pearls,

Men in medieval garb, furred gowns, and powdered hair.  
And some are rich, and some are poor, but no one frowns to-day,  
For all the world is one at heart when bringing in the May!

Untiring mirth and pastime hold till stars shine overhead,

And bonfires sink to ashes, and only night-birds call,  
And tired lads and lasses are dreaming in their beds;

Then Merry England sleeps again, and peace is over all.

Gerard the Giant's jousting-staff, that stood in Basing Lane,

Long since has crumbled into dust, the way of earthly things;  
And the "Great Shaft" of London will not be raised again;

But in the face of changes that Time forever brings,  
Were I to send old England a message of good cheer,

I'd wish her back her May-day with each merry year,

That all her lads and lasses might join the merry din,

And make the welkin ring again and bring the May-pole in!



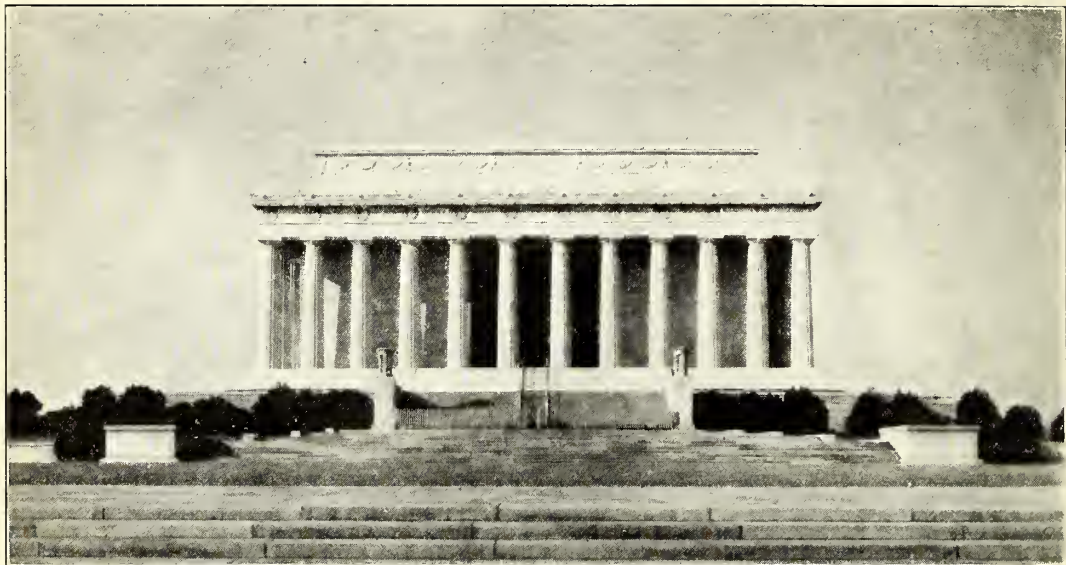

© Harris & Ewing

THE LINCOLN MEMORIAL AT WASHINGTON, TO BE DEDICATED ON DECORATION DAY—MAY 30, 1922

## A BOY'S RECOLLECTIONS OF MR. LINCOLN

By THOMAS S. HOPKINS

"TOMMY" was a round-faced, healthy country boy of sixteen when the Civil War broke out in 1861. He wanted to enlist, but his parents would not consent. He was persistent in his appeals to them. This continued for a year, and the war went on. Great battles were fought, and some of his older schoolmates were wounded and some were killed. Tommy was nearly beside himself, and finally, in June, 1862, his mother, giving way to the thought that perhaps duty was calling, yielded, and the boy was soon drilling with a new regiment under the shadow of the State House.

Perhaps one may gain some idea as to the character of his mother from the following incident. Tommy had been given two days' leave to say a final good-bye to his mother. The moment had come, and they stood together on the front steps of the old home. He was dressed in his new blue uniform, a rather youthful looking soldier. Her face was white, but there were no tears in her eyes and no faltering in her speech. She controlled her emotions for his sake. Down through the branches of the great elm that for more than a century had cast its shade over the lawn filtered the sunlight of a sweet June morning and seemed to form a halo

about her head. Gently kissing her boy, she looked into his clear eyes, and her last words were, "My son, never let me hear that you turned your back to the enemy!" Before the year had closed, he was in hospital with a gunshot wound.

Tommy's first view of Mr. Lincoln was soon after the battle of Antietam, in the fall of 1862. Mr. Lincoln had come to review the Army of the Potomac. Tommy and his regiment had marched a long distance in the early morning to reach the reviewing field, and then came a long, long wait. He was tired, hungry, and thirsty. But finally there came the sound of the bugles, and loud cries of "Attention!" from officers. A cloud of dust swept toward them from far down the line, and out of it gradually emerged a great number of field- and staff-officers, their horses galloping rapidly. At the head rode Major-General George B. McClellan, and at his side a civilian, dressed in black and wearing a high silk hat. The contrast between the latter and those who were attired in all the glittering panoply of war was very striking. In the passing glimpse that was obtained, about all that could be observed was that Mr. Lincoln was very tall and rode his horse



with wonderful ease. But in the fraction of the moment that Tommy's eyes rested on Mr. Lincoln, somehow the boy's heart warmed toward the great man, and he whispered softly to himself, "I'm glad I enlisted!"

After fourteen months at the front, Tommy was sent to a hospital in Washington. The next time he saw Mr. Lincoln was on the steps of the White House, one evening late in 1863. Mr. Lincoln came out of the front entrance and entered a carriage to be driven to his summer cottage at the Soldiers' Home, outside of the city. This was a close-range view.

The boy's father, in eating an apple, had the rather unusual habit of holding it in both hands. Mr. Lincoln, as he stepped out on the portico of the White House, was eating an apple, which *he was holding in both hands!* He had on the inevitable high hat, which he wore summer and winter. Still eating the apple, he passed down the steps, bowing and smiling, and entered the closed carriage. He had to bend his tall body very much before he could enter.

The thing that the boy remembers best and cares most to remember was the ineffable smile that flitted across Mr. Lincoln's plain and rugged face. It was not forced. It was as spontaneous as the loving smile of a mother looking down into the face of the child in her arms. Only the smile of Him who was meek and lowly could have been sweeter and more inspiring. But there was nothing about him that was imposing or awesome; no exhibition of the pride or arrogance, or even the reserve, that sometimes characterizes the attitude of rulers of great nations. The world now knows that he loved not himself, but his fellowman. The boy's heart warmed toward him, and he longed to hear him speak.

Tommy, having become unfit for service at the front, was detailed for duty in the War Department. From that time on, he saw Mr. Lincoln almost daily. Many times he saw him driving to or from his summer home, and usually he was followed by a body-guard of cavalry, with long lances, at the ends of which fluttered a tiny red flag. Frequently, after dinner, Mr. and Mrs. Lincoln drove for pleasure through the streets and parks. Sometimes the President walked, but not often. The boy heard him address regiments returning from the front, and he attended receptions at the White House and took the great man's hand. Later in the evening, Mr. and Mrs. Lincoln

would come into the spacious East Room for a few moments. It was a brilliant spectacle for this country boy to witness. The great men of the nation,—those high in official life, diplomats from foreign countries in court dress and bedecked with brilliant decorations, generals of the army in full uniform,—and ladies young and old, wearing such beautiful costumes and adorned with such glittering diamonds as the boy had never even dreamed of, were there, and excited his wonder. The crush was so great that the system of checking wraps, etc., frequently got out of hand; and on one of these occasions, Tommy lost his hat and was forced, much to his chagrin, to escort a very sweet girl home with no covering for his head. The girl forgave him, and, later, to emphasize the fact, married him; but she still teases him about it.

The boy will never forget the last time he saw this greatest of men. It was on Friday evening of April 14th, 1865. That evening, just before sunset, he and a companion were walking near the Navy Yard entrance, when Mr. and Mrs. Lincoln passed them in the White House carriage, evidently intending to drive through the Navy Yard grounds. The usual mounted body-guard was not in attendance. It was because of the absence of any guard, perhaps, that Tommy and his companion stopped and watched them pass. The lines in the President's face had deepened and lengthened. Otherwise it was little changed. It had not hardened. Rather it had softened and mellowed as does the face of one who has come through great tribulation with faith undimmed. The boy turned to his companion and said, "There is no other country in the civilized world where one may see the ruler of a great people riding on the streets with no guard or escort."

Four hours later Mr. Lincoln was mortally wounded.

It was a wild night in Washington. From Winder's Building, signal-lights were constantly flashing; from the circle of great forts that surrounded and protected the capital city could be heard the drums beating the long roll; squadrons of cavalry dashed through the streets, scabbards clanged against stirrups, and horses' steel shoes pounded the pavements; the streets downtown were crowded with excited, gesticulating men, some of whom were swearing who never swore before; and some, to whom tears hitherto had been unknown, were



crying, while a great mob filled Tenth Street, between Ford's Theater and the little house directly across the street, into which the unconscious President had been tenderly carried. Tommy was on the streets all night, going from point to point, gathering such news as he could, while his heart was heavy, for he now became aware of

last time upon that face, which in death seemed, if possible, nobler than in life. More clearly than ever before might be seen the dignity and nobility of soul which God had given him.

Four days afterward, Mr. Lincoln's body was borne down Pennsylvania Avenue to the railroad station. All Washington was there, silent and grief-stricken. The boy has seen all the great historic processions for which that avenue is noted, since Mr. Lincoln's second inauguration,—the Grand Review of 1865; the returning of the Spanish War and World War Veterans, the inauguration of all the Presidents,—but in solemnity, in the depth of feeling stirred up in the hearts of the people, in historic significance, nothing that compared with this.

Though the heavens wept when Lincoln died, on this day nature smiled her very sweetest. The sun shone brightly; the air was balmy; the birds sang; and it seemed as if Nature were trying to comfort a stricken people.

MORE than half a century has passed. The boy is now an old man. He has seen mighty events occur in the world's history, and in a very humble way has participated in some of them.

He looks back on a life of great activity, but there is nothing that he recalls in all the years since childhood, except the memory of his dear mother, that brings him such satisfaction as the fact that he saw Mr. Lincoln so many times

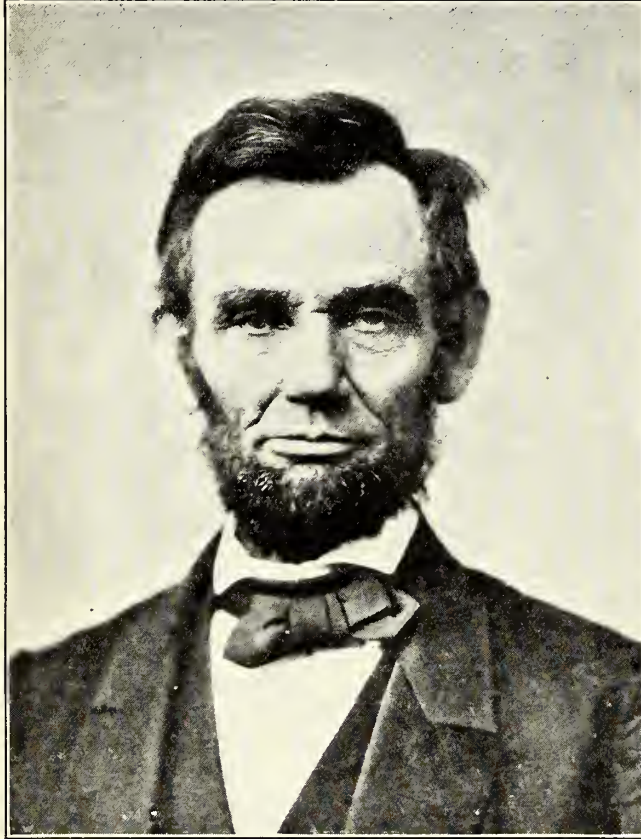

ABRAHAM LINCOLN FROM A PHOTOGRAPH TAKEN IN 1864

and actually took his hand and spoke with him.

the fact that he really loved Mr. Lincoln. In the early morning, the soul of that noblest and greatest of men took its flight heavenward, leaving behind a heartbroken, weeping nation. Yea, even the heavens wept, for all day long rain steadily fell. Secretary Stanton prophetically exclaimed when Mr. Lincoln ceased to breathe, "Now he belongs to the ages!"

Tommy next saw Mr. Lincoln in his casket as he lay in the White House. A guard of honor, with fixed bayonets, immovable as marble statues, surrounded him. Tears clouded the boy's vision as he looked for the

and actually took his hand and spoke with him.

Somehow, when as a boy he saw and heard the great man whom so many writers described as uncouth, he did not think him awkward or ungraceful. Instead, such a kindly light shone forth from those deep-set eyes, there was such a friendliness in that gentle smile, and there was such a spirit of frankness and sincerity in every feature, that almost any discerning man or boy might have seen that here was a man who loved his fellowman, and that in him dwelt the spirit of the Divine Master.

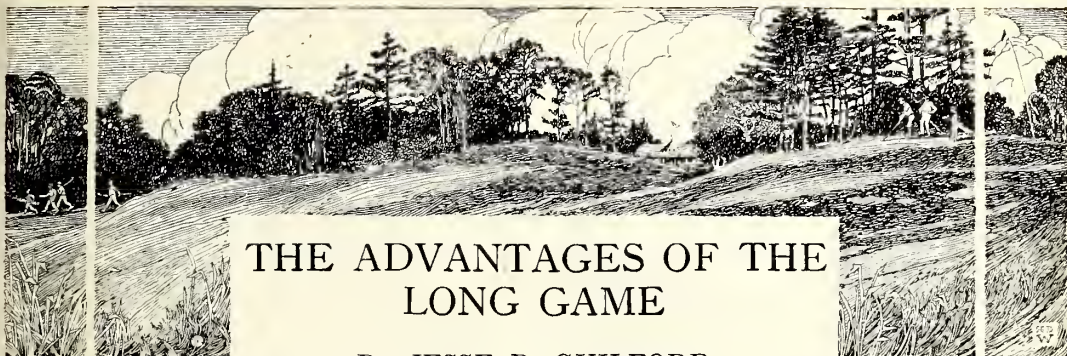

## THE ADVANTAGES OF THE LONG GAME

By JESSE P. GUILFORD

THE ambition of the youthful golfer is to drive like Abe Mitchell or some one of the other long hitters of the game. It is the thrilling stroke in golf which appeals most strongly to the boy, and the one which he practises most thoroughly. This is especially true of caddies, who, when not on the course performing caddie duty, spend their time swinging clubs. Some of them, as a result, become theoretical golfers; that is, they have an apparently perfect swing and follow-through; but when they apply it to the sending of the ball, they are unable to get good results. In practising they have failed to bring the club-head close enough to the ground, and when actually attempting to carry the ball through with the stroke, a topped ball, or absolute miss, ensues.

Some of our very best golfers, in both the amateur and professional ranks, laid the corner-stone to their success in their caddie days. Notable among the caddies who have achieved fame are Francis Ouimet and "Chick" Evans. Mr. Ouimet now tells many amusing stories of his first attempts at golf, his first practice-course being on a public street in the town of Brookline, where he lived. After he began caddying at the Country Club, he renounced his old course and spent a good deal of time playing around the Country Club course. Not being a bona-fide member of the club, he had to get in his round of golf early in the morning, and many times he would be just about finishing as the green-keeper arrived at the club to start his morning's work. Then Francis would be chased off.

Those who get discouraged with the amount of practice necessary in learning to play should take a lesson from Mr. Ouimet's early experiences. He was so enthused with the game, and so determined to master it, that he practised every available moment,

and that meant that he had to get up long before breakfast to steal a few hours of practice before the powers that be interfered.

My own early golfing experience was robbed of the glamour of thrilling escapes from the green-keeper, but nevertheless I put in hours of practice. The Intervale Country Club, in Manchester, New Hampshire, is about four miles from the city, and it was opposite this course that I lived. Unlike city boys, I had no playmates, my nearest neighbor living at least a half-mile away, and so I was virtually driven to the golf-course for amusement. My good parents, seeing in the game a sport which would keep me out in the sunshine, bought me my first set of clubs, and with them I tramped over the course day after day, trying to better my previous records. The fourth hole of this course is a dog-leg, and one day I decided to cut the corner of it. From that day on, I never played around the corner; I always endeavored to cut it. At first, I got into a lot of trouble and found some very difficult lies; but my efforts were finally rewarded, and I was able to drive across the corner and land on the fairway on the other side. It meant a long drive for me at that time, as I was only twelve years old, and to drive 225 yards was no small undertaking. I spent hours of practice on that one particular hole, and now, as I look back to those hours, I realize that that hole is the one which made me a long hitter. Had I been content to play around the corner, I should have been willing, when I got on other courses, to play the easiest way; but once having accomplished what I desired in the way of getting greater distance, I began to make a longer game my aim.

Now, I know most of you boys are interested in knowing how I get distance. One of my caddies once told me that he knew



how I approached and how I putted, but he had never been able to get my system of driving. There really is no secret; I believe that the most influential feature in my long game are my wrists, for wrists play a most important part in the making of a swing. The average golfer makes his swing in-



© International

GUILFORD FINISHING ONE OF HIS LONG DRIVES

stinctively; that is, he takes the most easy and natural method. Therefore, when any one asks him just how he makes a certain stroke, he is unable to analyze his movements. Last year I had a moving picture taken of myself while driving. The individual photographs were then made up into a little book, and by snapping back the pages quickly, a complete swing is given, while each photograph gives the position at the various stages. From this group of action photographs, I really learned more about my method of driving than in any other way; possibly because I never seriously considered what I did and how I did it. Of course, I

have at times experimented with different ways of using the club. For instance, at times when I have been off my game, I have reverted to the open stance, with the hope of remedying conditions; but during those times I found that I had a tendency to slice. All golfers are the victims of streaks of sloppy golf, and I presume that during those intervals of poor golf it is natural for a golfer to attempt new methods; but the wise one is he who just sits back and waits patiently for his game to return.

Now in no stroke of the game of golf am I so particular about my stance, my grip, or my swing as in driving. On the drive, one has an advantage in that he is able to tee up his ball, and in doing so I usually make a rather low tee. I would like to tell you boys a little incident in regard to my experience in gripping the club. When I first started playing golf I was my own teacher, and it was not until after I had won the state championship of New Hampshire that I took lessons; therefore it is not to be wondered at that I adopted the style known as the double-V grip, as it is the one which comes most natural to a beginner. In it the left hand grips the club from the upper side—that is, the knuckles of the left hand are showing. The right hand grips the club from the lower side, but is turned to meet the left hand; thus the thumb of the left hand is on the side of the club, and the thumb of the right hand is on the upper side of the club. With this grip, I got tremendous distance, much greater than I am capable of getting to-day, but I got it at the cost of direction.

While I was using this grip, I entered my first national tournament, which was at the Ekwanok Club, in Manchester, Vermont, in 1914. In the first round I met the late Fred Herreshoff, who was himself a long hitter, but with my full swing, which almost touched the ground in back, and through the use of the double-V grip, I recall that I outdrove him consistently. It was at that tournament that I was christened "Siege-gun" because of my long game. In the next round, because of my unsteadiness, I was eliminated by Roy Webb.

Shortly after this tournament I met Davie Brown, at one time open champion of Great Britain, and he cautioned me, "You'll never win a championship until you change your grip." He then advised me to change my grip from the double-V to the Vardon, and at that time I could not see how it would benefit me. At the end of the golfing sea-



son, however, I was sorry I had not heeded his advice, for my season had been one wherein the extreme distance which I got on tee shots was of no avail because the direction was so poor. In fact, I was fast attaining perfection on shots from out of the rough, so vast was my experience.

That winter I practised swinging indoors, using the Vardon grip instead of the double-V, and in the spring I felt well repaid for my efforts. I believe that the Vardon grip is more steady because, through its use, both hands have an equal amount of work to do. This grip is also known as the overlapping grip, because the last two fingers of the right hand overlap the fore and middle fingers of the left hand.

What I consider of most importance in the hitting of a long ball is the action of the wrists. In the first place, instead of gripping the club in the palm of the hands, I grip it well with the fingers; thus, by gripping it firmly, the action of the wrists is in no way impeded. My fingers are long and strong, and my wrists too are powerful. While in England last spring, one of the papers made the comment that I had a pair of hands more like a prize-fighter than like a golfer. It is my left wrist which starts the club head moving upward; about half-way up, my right wrist takes the work; and at the top of the swing, both wrists are very nearly under the shaft, with the toe of the club facing the ground. On the downward swing, just the reverse occurs of what took place going up, so that, at the time of the impact, the body and wrists are in virtually the same position as when the ball was addressed.

There is another thing which I try to follow religiously in driving, and that is not to exaggerate the pivot. I aim to avoid all sudden lurches, and strive to have the body turn gradually and with a certain rhythm. A good many caddies have asked me if I do not put an extra snap into the swing just before hitting the ball, and when I explain to them that the distance which I attain is the result of a natural, easy swing, with no extra push here or lurch there, they almost seem to doubt my word. As far as I can judge, there is no snap to the wrist just before the impact—simply, the club on its downward journey is swifter than on the upward, but just as smooth.

There are a lot of young players, all of whom are long drivers, or who play a long game generally, who are going to be heard from in future big tournaments. Bobby

Jones has already made a name for himself among the foremost golfers in the country, and this year at St. Louis several other young players made themselves conspicuous by their excellent playing. Harrison Johnston, of St. Paul, is the youth who impressed me most favorably, and I believe his success in the National this year was due to his long

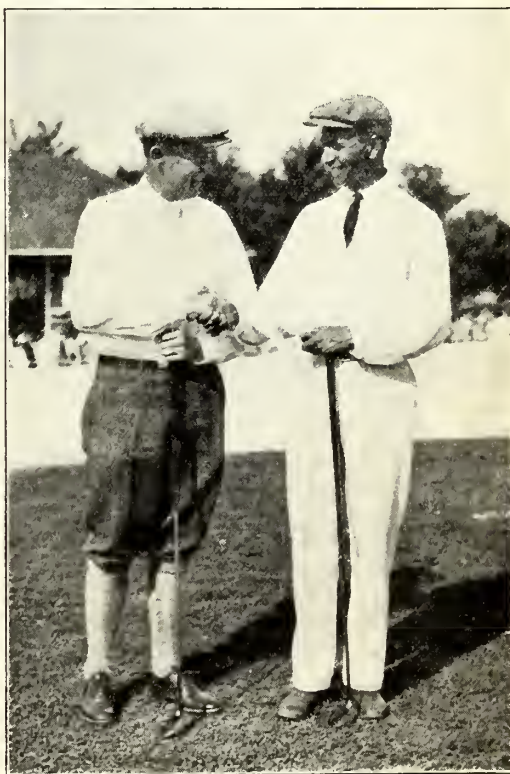

Photo by Edwin Levick

ROBERT GARDNER, RUNNER-UP, CONGRATULATES THE CHAMPION

game. In the second round of the tournament, Johnston met Francis Ouimet, and, to the surprise of all, defeated this veteran player. Johnston won, I believe, on his tee shots and his putting, for his iron play is not as finished as it might be. Francis Ouimet is one of the long hitters of the game, and it was thought by those who witnessed the match that he would far outdrive his opponent; but this was not the case. Johnston played virtually the same length game as did Francis; and when Francis's putter failed to work, Johnston's was right there, with the result that Johnston emerged the victor by a single hole.

It was up to me, the following day, to avenge my club-mate's defeat, and I want to say right here that I was surprised at the

battle which Johnston gave me. In fact, his match with me proved to be the hardest one which I had during the entire tournament. Johnston's tee-shots were fully as long as were mine; and during that round, there were several very long shots made. In addition to this, he putted very well. As

to hover around par, so I naturally thought that I should have a big advantage over young Quinlan on this feature of the game. Right there I received a second shock; for on the very first tee, he showed his metal as a golfer by whaling out a ball just as far as mine and straight down the middle.



Photo by Edwin Levick

GUILFORD DRIVING FROM THE EIGHTH TEE AT ST. LOUIS DURING THE NATIONAL AMATEUR TOURNAMENT

soon as this player improves his approaching methods, he is going to be a big factor in championship golf, for his long game served him well this year; and with practice on his short strokes, he will cause a great many more upsets.

Now I'd like to tell you about another young player in this State who "threw a scare into me" during the amateur championship of Massachusetts. This championship took place in July in some of the hottest weather in which I have ever played. The thermometer was floating around the 100-degree mark, and we had had day after day of this intense heat. On Friday morning, I was scheduled to meet young Billy Quinlan, and if I won my match with him, and Francis Ouimet won *his* match, we were scheduled to meet in the afternoon.

There is no use denying the fact that I went out with the idea of soon disposing of this kid, and this impression was general, for a large gallery was gathering to witness Francis and me play in the afternoon. On my way to the first tee, one of my friends said to me, "Take things easy this morning, Jess, because we're all looking for a good old match between you and Francis this afternoon." So I started playing with that intention, but to my dismay I learned that I was up against a tough opponent. The Worcester Country Club has a fine course, and one which requires a long game in order

Well, Billy played a wonderful game, and it was a nip-and-tuck battle all the way. We went to the eleventh hole all even; and if you will believe me, that boy halved the twelfth, the thirteenth, the fourteenth, and the fifteenth. I won the sixteenth, only to lose the seventeenth, and we went to the last hole again all square. Just at this point, the same man who had cautioned me to take it easy appeared on the scene again. "Say, you've got to win this last hole," he said. "No need of taking it to an extra hole. Just win now, because there's a big crowd gathered to watch you and Francis this afternoon, and don't disappoint them." We both got off good tee shots, and my approach left me a long putt. I was so exhausted and dizzy from the heat that I hardly dared look down to get the line. I putted hastily, with faint hope that it would sink, but it rolled cozily into the hole, and the match was won on the eighteenth.

What I think augurs particularly well for this boy's success in future tournaments is that he did not permit himself to be handicapped mentally. While he was rated as one of the State's coming golfers, no one suspected that he would carry me to the last green; and yet he did n't let this interfere with his game. He played splendid golf, and gave me a battle which I shall never forget.

There is one time above all others when



the long game comes into its own, and that is on the rainy day. In wet weather, or playing on a windy day, the man with the distance has a distinct advantage. This has been demonstrated many times, but never more decisively than last year at St. Louis in the semi-finals. Thousands of golf fans awoke that morning to find it pouring rain, but it took more than this terrific down-pour, mixed with a thunder-storm, to curb their interest in the matches which were scheduled for that day. In the semi-finals, Robert Gardner, past national champion, was matched against the little British champion Willie Hunter, and I opposed Chick Evans, who was then the champion. Willie Hunter is what is termed a "short, accurate player," whereas Chick Evans gets about average length; but with the heavy going, these men were severely handicapped, and both lost their matches.

In so highly recommending the long game, I do not wish to encourage pressing. The boy taking up golf should make a long game his aim just so far as it does not interfere with accuracy. Pressing is absolutely fatal to one's game; for in so doing, the player in one day is trying to get an additional fifty or seventy-five yards, with the result that he succeeds only in topping his ball, or perhaps he hooks or slices. At any rate, he is the loser. The youth who is striving for distance should try to get it gradually; that is, as his game becomes more accurate, he should attempt to add a little more to his length. But the minute he finds that, in order to increase his tee-shots, he has to "slug" at the ball, he should cease. Length is something which will come with practice, and with practice alone. It is much easier to practise when one is young than in later years; for after one gets into business, his time on the golf course is so limited that he wishes to put that time into playing the game and not in solitary practice. Now if any

of you boys want to excel in this game of golf, you must give up a match or two a week and put that time into practising.

Do not practise with your driver only; practise all the shots; for a long, accurate drive is worthless if a poor or indifferent approach follows. Then there is another thing to be taken into consideration, and that is no matter how long or how accurate your game is to the green, you can not afford to waste shot after shot there. Now is the time for you to mold your game; and if you wish to become a long hitter, practise with this end in view, but avoid all tendency to become a slugger. In this connection



Photo by Edwin Levick

JESSE P. GUILFORD, THE UNITED STATES AMATEUR CHAMPION, AND THE CUP HE WON

let me remind you that many matches have been won by long hitting; and those players who have won matches through their long game will tell you of the matches which they lost because they could not get their drives going right. The long game is decidedly advantageous on those days when the shots are going right, but the slugger has not a chance against the man who is playing well within himself. Therefore, if any of you boys want to become future champions, make the long, accurate game your purpose; and above all things, practise now, while you have the opportunity.

## THE LAZY FLOWERS

"MY pansies are so lazy!"

Little Janet said.

"Even when I get up quite late  
I find them in their bed!"

*Charles Hanson Towne.*



# THE AFFAIR OF FUZZY'S FURNITURE

By ETHEL AMBLER HUNTER

"It would be simply superb," Winona Peach assured the rest of the senior play committee, "if we could get Fuzzy Conant's furniture and things for the second act. Of course, we can collect enough stuff eventually, by begging all over the campus and blarneying about a dozen people, to say nothing of janitors. But think how easy it would be to gather the whole outfit in one place—just transfer Fuzzy's room bodily, and set our stage at one fell swoop!"

The rest of the committee, who had been sitting for an hour in the chilly gloom of the college auditorium dubiously regarding the bare and unpromising stage they must transform somehow into "the drawing-room of Mrs. Throckmorton's country estate," brightened visibly at this happy thought of their chairman.

They were in that dark mood, only too well known to any one who has ever tried to put on a play, when the whole thing seems foredoomed to failure—when all the acting is stiff and tiresome, the lines dull and the situations flat, stale, and unprofitable. The four seniors had been especially depressed by the specifications for that luxurious interior in the second act. Dispiritedly they had gone over all the available material. There were a few things in the newer dormitories that would do—"very few," they agreed loftily. There were also sofas and chairs and such, which could be borrowed from sorority houses. "But every play since 1900 has used some or all of those, and *do* let's try for something new and elegant," Winona urged eagerly. Then she had thought of Fuzzy Conant.

"At times, Peachy darlint, you have a really bright idea," admitted Cary Birch, who could paint splendid woodland scenes and ferny grots and moonlight effects, but had failed them when it came to interior decoration. Since she had, almost single-handed, evolved a garden scene for the first act, complete even to a sun-dial and marble benches (which were quite strong if one sat down on them with care), she felt that some one else might "do a little something now," as she put it frankly.

"Of course, I don't mean to reproduce Fuzzy's room exactly," went on Winona, "though it's perfect just as it is. But her

things are so stunning, and we can get the effect of spaciousness and dignity with oak paneling. I just know you could do oak paneling, Cary."

"Paula can do the paneling," Cary put in hastily. "I have a paper in psych. due Thursday, and I have n't done a thing on it yet. Besides, my room-mate says I smell so of paint she simply can't stand me. You just do the walls two thirds of the way up with dark-brown paint, Paula, and then get a thing at the hardware store called a grainer. It streaks the paint in designs to imitate the grain of the wood, you know."

"Oh, I *don't* know!" wailed Paula, unhappily. "I never had a paint-brush in my hand. But I'll try it; I suppose it will round out my education."

"And I'll see Fuzzy about the furniture," Peachy promised, "and Mr. Kelly, at the stable, about a wagon. Let's see; we'll need the things here Friday afternoon, for the dress rehearsal."

Winona secured the promise of the wagon first, for she felt pretty sure of good-natured Fuzzy Conant. That young lady blinked a bit when Winona declared airily that she'd want "just about everything" in room 57, College Hall; but she could not refuse when her classmate assured her that the success of the play depended upon it.

"I don't know what Aunt Nellie would say," she declared feebly; "but if you think nothing else will do—"

"Nothing else will," Peachy stated with firmness, and gazed appreciatively around the other girl's lovely room. Fuzzy's aunt had, in some remote period in the history of the college, been a student there and had "worked her way through" with a good deal of difficulty and self-denial. She had occupied a shabby and dismal room, meagerly furnished and adorned not at all; and when, in later years, mistress of a generous income and a beautiful home, she remembered her academic career, she always sighed at the memory of that ugly, depressing little cell of hers.

When, therefore, her niece elected to go to the same college, she took special pleasure in lavishing upon her all the beautiful things she had hungered for in her own youth, and Fuzzy had the most unusual room on the



campus. While other girls did what they could with wicker tables and Morris chairs and chintz, Fuzzy had mahogany and Oriental rugs and wonderful brasses and pictures.

She had also (for nothing is perfect in this world) a room-mate; and Fuzzy's friends

"There's no one like Leonida," she declared loyally on all occasions when her "roomie" was criticized, and her friends, exchanging meaning glances, would echo, "No one!" with a mirthful vehemence that greatly distressed the faithful Fuzzy.



"IT WOULD BE SIMPLY SUPERB IF WE COULD GET FUZZY CONANT'S FURNITURE'"

were accustomed to aver that if you had gone the length and breadth of the campus, you could have found no one so totally unsuited to Fuzzy and Fuzzy's perfect room.

Leonida Still was a plain little thing, studious, reserved, and quiet; also, a bit disagreeable when Fuzzy's friends, "running in" at all hours, interrupted her work. But Fuzzy was devoted to her.

"I'll have to consult my room-mate first," she faltered now. "You won't be able to get the things back here after the play Saturday night; it will be Monday afternoon at the earliest, and Leonida hates a disturbance and a mussy room. She's as methodical and scholarly as—as I wish I were. I suppose you'll want the secretary; she uses that all the time."



"Absolutely got to have it, dear; I'm building the whole room around that. There's such an air of distinction to the old thing. May I ask why your lit'ry roommate has to have *your* secretary?"

"Well, it seems to suit her," Fuzzy explained vaguely. "I'd just as lief study at the library—but I have n't told Aunty so," she added, grinning. "There's the gong. I have a nine-thirty class—where's my notebook—Coming?"

This was on Wednesday. It seemed best not to break the news to Leonida too suddenly, for Leonida had a narrative description for her advanced class in composition, due Saturday morning, and was writing feverishly in all her spare moments. To disturb her fine frenzy of creation would be cruel; Fuzzy decided to leave it till Friday. But Friday the geology instructor elected to take Fuzzy's class on a field-trip to study a terminal moraine; and before they got back, the play committee, supposing of course it was all right, came with a wagon and Mr. Kelly and stripped Number 57 bare. "Is n't it lucky the top of this thing comes off!" Peachy grunted breathlessly, as she and Paula helped Mr. Kelly lift the upper part of the secretary, with its delightful "bonnet-top" and glass doors, into the elevator. "You empty the papers and things out of the drawers, Paula, and, for mercy's sake, spread them out on the couch with care. Where Leonida will put them when she wants to go to bed, I don't know; but we can't help that. Now the seven-branched candlesticks, Cary, and the bronze and that cunning little tip-table—and I guess that's all. Let's go, Mr. Kelly!" And the elevator clanked solemnly down with its load.

Dust and silence settled down over Number 57. Six miles out of town, Fuzzy, hot and tired, with gravel in her shoes and hatred of terminal moraines in her heart, scribbled a few terse notes and hoped against hope that she would get back in time to warn Leonida. In the auditorium, the play committee set up the "drawing-room of Mrs. Throckmorton's country estate," a little dazed by their own success as they viewed its stately charm. And over at the zoölogy laboratory, Leonida finished an extremely trying dissection of the nervous system of a frog, gathered up her notes, put away her microscope, and hurried home to work on her theme. Some subtle final touches were all it needed; and after a long afternoon of science, Leonida looked forward to working

on it in the peace and comfort of Number 57.

When she opened the door of this haven of rest, it was quite dark, but some echoing quality of emptiness made itself felt even before she snapped on the lights. When she did so, she stood transfixed on the threshold; was she dreaming, or was this really the attractive apartment she had left in tranquil order directly after lunch?

At this moment it looked about as cheerful and cozy as a store-room or some one's back attic. There remained in it only a bookcase, a couch (Fuzzy slept in the alcove bedroom adjoining), and a confused jumble of hockey-sticks, golf-bags, and assorted footgear which had reposed tidily out of sight in the corner behind the secretary, but which now seemed to sprawl over half the room. One glance at the mass of papers on the couch, and Leonida knew the worst.

"There's at least one evening's work just to sort over that material!" she said tragically. "There's my field-notes and my history-ten paper in the rough and my daily themes; and as for my narrative description—!"

Leonida's plain, intelligent face set like flint; her fine eyes glittered behind their glasses, and she started hunting for her rumpled story with an ominous, steely calm. She knew quite well where the secretary had gone; she had often seen harassed members of committees begging "props" and piling them into a wagon just before some dramatic event.

"But no one in college except Fuzzy would lend everything she owned," Leonida thought bitterly. "Upsetting my work like this—just for a play! I'll never forgive her, never! It's outrageous; I'll ask the registrar to let me move—I can't stand such a butterfly of a girl another minute. Not a mite of character—no sense—no heart!"

It boded ill for Fuzzy.

Just before that impetuous young woman bounded in, however, Leonida had a saving thought. After all, she reminded herself grimly, the things *were* Fuzzy's.

"I think you might have told me," was all she said to Fuzzy's wild torrents of lamentation and apology; "of course if you don't mind lending the valuable things your aunt entrusted to your care,—and since you don't get upset by confusion, as I do,—I suppose it is all right. Only I can't perfect my theme now, of course. I think I shall go out for a long walk; I just know I shan't sleep a wink to-night. No—I do not care

for any dinner— No thank you; I'm perfectly all right. Good-night." And she departed with a martyred air which cut Fuzzy to the heart.

Her freezing aloofness lasted all the next day, and by 7:30, when every one on the campus was wending her excited way to the auditorium, it became apparent that she was actually going to cut the senior play. Poor Fuzzy was horrified.

"It's all my fault, too," she said unhappily to herself. "Whatever makes me do such thoughtless things!" Her evening was quite spoiled; she could not enjoy the play; even the wonderful stage-setting of the second act, which her own belongings so much adorned, failed to thrill. She was haunted by the memory of Leonida, writing grimly on the crowded, inconvenient bureau-top, back in the disorder of their quarters.

How could she guess that Leonida, queerly enough, was haunted too? The deserted corridors of College Hall were unearthly quiet; she was increasingly conscious of being the only student in the whole huge building, except a girl with a sprained back and another with an ulcerated tooth. To tell the truth, the unwonted silence of the dormitory, which she had told herself was just what she wanted, was beginning to get upon her nerves. She could not study, in spite of the appropriate atmosphere of academic calm. She kept thinking of Fuzzy's imploring eyes, and all the kind and unassuming ways which made her so lovable.

"I've never done one thing to make her so nice to me," she said at last, tossing aside her work. Her conscience, having succeeded in getting her whole attention, now proceeded to make her perfectly miserable. "Anybody'd think I was the popular and generous and jolly one, the way she waits on me. And when I think of the way I've gone on accepting things from her—it's sickening! It's about time, Leonida Still, that you did something for Fuzzy for a change, and you can begin by—"

At this point Fate, in the person of the maid "on bells," knocked at the door and provided something quite unexpected and plenty hard enough for any penitent person to "begin by."

"Miss Conant's aunt has come," announced the girl. "No, she won't come up yet; Mrs. Sheppard told her Miss Conant had gone to the play; and she and the aunt are old classmates and they're visiting together down in the parlor. But Mrs. Shep-

pard thought you might like to know she was here, seeing she came unexpected-like." With a curious look around the dismantled room, the maid departed, smiling.

"Now if it's any aunt under the sun," Leonida thought wildly, "it will be bad enough to have to entertain her in this dreary place. If it is Aunt Nellie, it will be awful! And I don't think Fuzzy has any other aunt. Something has got to be done."

In about thirty seconds, Leonida had made up her mind—that keen, quick, organizing mind of hers. In about five minutes she had fled down the stairs, out across the dim campus, and stumbled into the hushed and darkened auditorium, where she stared about her, considerably dashed. She saw at once that there was no hope of finding Fuzzy in that crowd of silent, absorbed spectators. And she could not wait for the play to end; time was too precious.

Just then an usher noticed her, a tall, friendly sophomore, who tiptoed up to her and whispered, "Is there anything I can do for you?"

"Do you know where Fuzzy Conant is sitting?" Leonida queried breathlessly; "or do you think you could find her after the play and tell her she's wanted up at our room immediately? Her aunt has come."

"Not the one who gave her all the furniture? My stars!" exclaimed the sophomore. "And all her things out in the anteroom this minute. They're through with them now; the third act has just begun—if only there was some way we could get them back to College Hall—"

"Just what I intend to do," stated Leonida, shortly. "There's a wagon sitting out back there—can you get hold of three or four other girls to help? It would n't take twenty minutes."

"Positively, I never saw her like this; actually a human being!" murmured the sophomore, as she proceeded to round up some of the other ushers and dragged them, protesting, but curious, along the rear of the building to the anteroom door, where Leonida had already backed the wagon. Quickly and quietly the six girls loaded Fuzzy's belongings, tiptoeing around in the heat and dust lest they disturb the performance going on on the other side of a thin partition.

"Even at this moment," they heard the hero thunder, "we know not who is in the next room, planning a desperate move against us. Knaves are all around us, plotting and plundering!"





"I 'VE BEEN PICTURING THE ROOM JUST LIKE THIS FOR THREE YEARS"



Stuffing their handkerchiefs into their mouths to restrain their mirth, they gathered up the last of the bric-a-brac and considered the secretary with doubtful eyes. It towered up in a terrifyingly massive way; but a bit of comedy in the play just then made it possible to drag it over to the door, under cover of the laughter and applause; then they lifted off the top, and, by padding the end of the wagon with rugs, slid the heavy lower part over the tailboard and the deed was done.

"When we get to College Hall, there 'll be the janitor and an elevator," Leonida sighed gratefully. "Now—is everything here? The winged chair—the tea-wagon—the candlesticks—the bust of Shakespeare, the bronze Mercury—the tip-table— I think so. Will some of you people come along?" she appealed to them as she took up the shafts.

"Will we? Depend on us!" the girls responded with enthusiasm, and off they trundled the wagon, down the slope in the direction of College Hall.

The play ended at nine-thirty. It was nearly ten when the frenzied committee and Fuzzy Conant trailed their weary and excited way homeward.

"What I can't imagine," Peachy was saying tragically, "is how any one could have stolen all that furniture when I was prompting in the wings myself—leaning right against the partition, and did n't hear a thing! There must be some explanation."

"Well, my things are gone, that 's sure," poor Fuzzy said with forlorn conviction. "Here I 've had that furniture for three years, and Auntie has never once visited me. Now that nobody knows where it is—even if she does n't mind my having lent it for the play, she will think we might have prevented it vanishing from the face of the earth. My goodness, girls, you 'll have to stand by me!" she ended solemnly.

"Leonida will have prepared her for the worst by now, I suppose," remarked Cary.

"Trust our tactful Leonida!" Paula snapped, and they all noted that for once Fuzzy did not say, "There 's no one like Leonida."

Instead she said: "Well, here we are. I suppose we have to face the music."

They crowded into the elevator speechlessly; walked the length of the corridor like persons going to their doom, and paused one last dreadful moment on the threshold.

"Cheer up, honey. We 'll take all the blame; and when we explain, it will be all right, anyway. Your aunt is such a dear," whispered Peachy, encouragingly, and then—she opened the door.

The first thing their frightened eyes rested upon was the secretary, looming up in the corner, familiar as an old road in a dream. And over by the fireplace, the winged chair—and on the mantel, the candlesticks—and by the window-seat, the tea-wagon—and on the tip-table, the bronze Mercury—and on the bookcase, the bust of Shakespeare; Fuzzy had taken an inventory before anybody could speak. Everything was there and in beautiful order. Leonida, the picture of gracious hospitality, had even started cocoa to boiling and rummaged out some cookies and cheese-sticks, while Aunt Nellie, radiating pride and pleasure, was arranging plates and cups, and turned to beam on them all impartially.

"This, Frances darling," she said presently, when the greetings and explanations were over, "is like a dream come true. I 've been picturing the room just like this for three years."

Across the room, Fuzzy caught the pleased, shy glance of Leonida, and smiled back a grateful and heart-healing smile.

Then she turned to the tired committee, relaxed on the couch beside her, blissfully drinking Leonida's comforting beverage. "Oh, I tell you," she said under cover of the general hubbub, "there 's no one like Leonida!"

And for once there was no one who scoffed.

## THE HUMMING-BIRD'S NEST

A BIT of lichen, a bit of down,  
A "ruby-throat" the whole to crown,  
And on the orchard branch there lies  
A miracle before our eyes!

*Emma Peirce.*

## ROBIN REDBREAST

WHEN Robin Redbreast comes to town,  
Good tidings he will bring,  
Because he is the messenger  
And dearest friend of Spring.

*Kitty Parsons.*



# THE STORY OF THE PHONOGRAPH

By WILLIAM H. MEADOWCROFT

*Author of "Boy's Life of Edison," "A B C of Electricity," etc.*

PAGANINI is still revered as the greatest of violinists. A hundred years ago he moved audiences to tears; the world rang with his praises. How does he compare with the great violinists of our day? Was he so astounding to those who heard him because he was indeed a greater artist than any who have since played a Guarnerius or a Stradivarius? We can never know. His music is stilled. And what of the matchless voice of Malibran, of Chopin's delicate rendering of his own nocturnes, of Garrick's moving interpretations of Shakespeare? We must rely upon the cold, printed words of contemporary enthusiasts and critics. How was English spoken in Shakespeare's day? Should we understand the actors who played in the Globe Theatre in Queen Elizabeth's time? Perhaps. Perhaps not. We have no standards of comparison. We can only guess from rhymed poetry, from the accents of blank verse how Shakespeare pronounced the English tongue. What would we not give if we could revive the voice of Patrick Henry, and thrill, as his hearers once did, to his "Give me liberty, or give me death!"

When we deal with sound we deal with a fleeting thing. It dies a moment after it is born. For what is sound? Nothing but a disturbance of the air. We speak, and perhaps from our lips come mere puffs, but puffs so wonderfully formed, so infinitely varied in frequency and strength that nothing short of a miracle happens. We receive these puffs on our ear-drums; we translate them; we give them the meaning that they are intended to convey; in a word, we hear. Because he expressed himself in mere disturbances of the air, in pressure-waves or puffs, the great orator or singer or musician of the past lived only for his own time. When he died, he became but a tradition.

Dozens of inventors had attempted to immortalize the artist of sound long before Edison succeeded literally in embalming human speech and musical notes and revivifying them at will. There was Leon Scott, for example, who invented the "phon-autograph" in 1857, sometimes erroneously referred to as the forerunner of the phonograph. But what was it? Nothing but an instrument by which the puffs of air that we

call sound were made to vibrate a marker, which in turn played on a piece of smoked paper and thus traced wavy lines in soot. There was no way of hearing again the sound that had produced the wavy lines. Scott had invented merely a way of enabling sound to trace a symbol of itself—a method of sound-writing. His wavy lines scratched in soot were no better than printed words when it comes to informing us how the great singers of his day trilled their notes; for it was impossible to make the wavy lines talk or sing again.

It was not until Thomas A. Edison invented the phonograph in 1877 that the world was enriched with an apparatus which did for speech exactly what the photographic camera did for light. How original was the invention is shown by the course of the specification in which it was first described in the United States Patent Office. A patent is not granted in this country unless the invention that it discloses is new—new in the sense that it is markedly different from any related device that may have been known or used before. Edison filed his application for a United States patent on December 24, 1877. A patent was issued to him on February 19, 1878. Not a single "reference," as it is called, was cited against him; which means that the examiners of the Patent Office had been unable to find a description of anything even remotely like his phonograph in all the technical literature that they were required to ransack in accordance with the regulations.

Curiously enough, the idea of the phonograph came to Edison at a time when he was more interested in telegraphy than in anything else. During the summer of 1877, he had been engaged in the invention of a telegraph repeater—a labor-saving device which was intended to record in a central office telegraph messages received from many outlying country districts and to transmit them mechanically to their destinations at more than human speed. The need of such an instrument was apparent. A telegraph operator could send only thirty-five or forty words a minute. If scores of messages sent in to a central station could be repeated by some machine at a speed of a hundred words

a minute, for example, there would be an enormous saving in time, money, and labor. It was but natural that Edison, the man who had done so much to improve telegraphy, should be fascinated by the possibilities of a repeater.

The repeater with which Edison was experimenting during that eventful summer of 1877 bore a curious resemblance to the

rates of speed. When the disk turned very fast, he noticed that a musical note was given out.

To another man, the musical note would have meant little. Why was it produced? The little embossing point had been made to vibrate like a tuning-fork as it passed rapidly over the indentations. The ordinary scientific mind would have been quite satisfied

with this obvious explanation and would have passed on. But Edison's is one of the most imaginative minds of which we have any record. An ordinary occurrence is to him what the pressure on a trigger is to a loaded gun. Something like a mental trigger must have been pulled on that memorable day, for he wrote down the following observation in his note-book:

Just tried experiment with diaphragm having an embossing point and held against paraffin paper moving rapidly. The speaking vibrations are indented nicely, and there's no doubt that I shall be able to store up and reproduce automatically at any future time the human voice perfectly.

Evidently he must have shouted against the diaphragm with encouraging results.

A musical note emitted by the rapid passing of a point over indentations on a piece

of paper—and from this flashes the idea of preserving for "any future time the human voice perfectly!"

The idea preyed upon him for days. It crowded everything from his mind. It took mental shape. He could see in his mind's eye exactly how a machine would look that would first record and then reproduce the human voice. The machine must be built then and there.

He knew that he must have a diaphragm of some kind,—even our ears have diaphragms, which we call ear-drums,—for

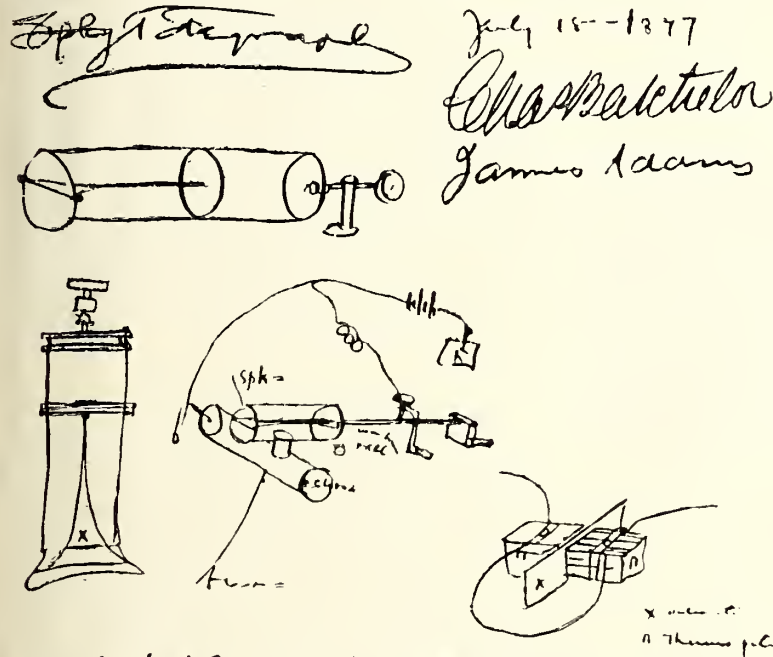

just tried experiment with a diaphragm having an embossing point & held against paraffin paper moving rapidly the Sply vibrations are indented nicely & there is no doubt that I shall be able to store up & reproduce automatically at any future time the human voice perfectly

FROM A PAGE OF EDISON'S NOTE-BOOK, SHOWING THE GERM OF THE PHONOGRAPH IDEA

modern disk-phonograph. Upon a revolving metallic plate was a disk of paper; above it, an electromagnet carrying an embossing point. When the electromagnet was connected with a telegraph circuit, the pivoted arm moved up and down, and the embossing point indented upon the revolving paper disk the dots and dashes as they came in over the telegraph-line. By reversing the operation, these dots and dashes could be automatically repeated over another telegraph-line at a higher or lower rate of speed. Edison tested this apparatus at varying



there must be something with a surface large enough upon which the puffs of air that came from the lips might beat. He coated some strips of paper with paraffin-wax, and these coated strips he passed by hand up and down behind a diaphragm, to the center of which a little steel point was fastened. "Hoo, hoo, hoo!" he shouted against the diaphragm; whereupon the little point would embed itself more or less in the coating of paraf-

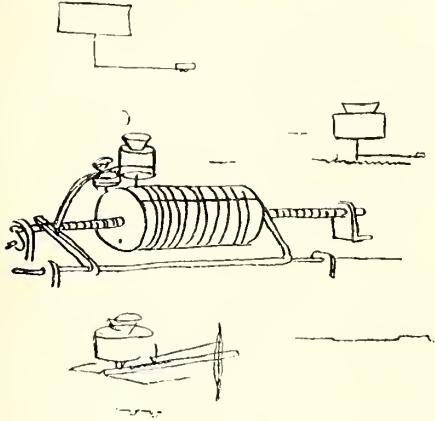

*Kruesi*  
*Make this*  
*Aug 12/77*  
*Edison*

FACSIMILE OF EDISON'S SKETCH FOR THE MODEL OF THE FIRST PHONOGRAPH

fin. He reversed the motion of the coated paper slip and listened. Very faintly there came back his original "Hoo, hoo!" He had made the diaphragm vibrate exactly as it had done when he had shouted against it. He had made it puff the air, made it set up pressure-waves like his own.

Paraffin was too soft. The record was easily destroyed. Perhaps some hard wax would answer. To find such a wax meant many months of patient searching and testing, and he was all aflame with eagerness to obtain immediate results. Perhaps tin-foil would do—something soft and pliable, yet more permanent than paraffin. On August 12, 1877, he made a rough drawing of a device which was destined to be the first phonograph, and wrote upon it, "Kruesi—Make this." The illustration on this page shows a facsimile of this historic sketch.

The Kruesi to whom this brief command was given was the late John Kruesi, a faith-

ful and able instrument-maker and a co-worker with Edison for many years. It was Edison's custom to give him not only the precise instructions that he needed, but also to place a limit upon the amount of money that was to be spent. In this instance Kruesi was informed that he could spend exactly \$18.

Kruesi had made many a model for Edison, but this was the queerest that he had been ordered to build.

"What's it for?" he asked.

"I want it to record talking," said Edison.

"It's a crazy idea," was Kruesi's comment.

Rumors of Edison's new machine spread in the laboratory. The men who worked for Edison had seen him accomplish wonders, but this notion of a machine that would talk like a human being proved too much for ready acceptance. Carman, the foreman of the machine-shop, said: "I'll bet you a box of cigars that it won't work." To which Edison replied, "We'll see."

#### THE FIRST TRIAL OF THE PHONOGRAPH

In a few days, Kruesi finished his model and laid it on the table of the "old man," as Edison was even then called, although he was only thirty years of age. Edison looked the model over to see if his instructions had been carried out. Kruesi stood beside him, curious and amused. He watched the "old man" turn the handle—a test of the machine's free-turning ability. He saw him take a sheet of tin-foil, wrap it around the cylinder, and fasten it with a strip of lead laid in a groove cut for that purpose. By this time the entire laboratory staff had gathered around the table, watching the proceedings with ever increasing interest and offering facetious advice.

Edison calmly proceeded to adjust the speaking mouthpiece. Then he turned the cylinder by means of the crank, and shouted into the mouthpiece:

"Mary had a little lamb,  
 Its fleece was white as snow,  
 And everywhere that Mary went  
 The lamb was sure to go."

The fateful moment had arrived! Edison saw that there were indentations on the tin-foil. He expected to reproduce only an encouraging fragment of a word here and there, or to obtain a few recognizable squeaks, at best—something to show that at least he was on the right track. Amid the joking and laughing of his men, he turned back the

cylinder, adjusted the reproducing diaphragm, and once more rotated the cylinder. Back from the tin-foil came a thin small voice:

"Mary had a little lamb—"

Not a word was missing! The phonograph was born!

Amusement, laughter, incredulity gave place to an awe-stricken, intense silence. Then the wonder of it dawned on Kruesi and the rest. Edison himself was amazed. A new strip of tin-foil was put on the cylinder. Again, perfect reproduction.

Now the reaction set in, and the men joined hands and sang and danced around Edison. It was a memorable day—and night also—at the Menlo Park Laboratory, for the entire staff stayed until dawn, taking turns at speaking, singing, laughing, and whistling into this first crude little phonograph and listening to their own voices with childish delight and enthusiasm.

#### HOW THE WORLD RECEIVED THE PHONOGRAPH

THE next day, Edison took the model under his arm and went over to the office of the "Scientific American," in New York, and told the editor, Mr. Alfred E. Beach, he had something to show him. Placing the model on a table, Edison put a sheet of tin-foil on the cylinder, turned the crank, and recited "Mary had a little lamb." He then adjusted the reproducer and rotated the cylinder. Again the voice and words were reproduced loud enough to be heard all over the room, to the intense amazement and awe of Mr. Beach and the bystanders who had come flocking around. Of course, there was an incessant demand for more demonstrations, and they were given until the crowd grew so great that Mr. Beach became anxious about the carrying capacity of the floor.

The following morning, the newspapers were filled with the news of this amazing invention, and the fame of it spread quickly throughout the world. Edison was deluged with letters, telegrams, and cables from every part of the globe. Every one wanted to see, hear, or possess this latest marvel.

So great and insistent was this demand that Edison was compelled to manufacture and sell tin-foil phonographs. He made some improvements over his first model and decided on two sizes, of which he had a quantity made in the little shop of Sigmund Bergmann, one of his former workmen, who had been manufacturing some of Edison's telegraphic apparatus in New York.

These first phonographs with tin-foil records were mostly used for exhibition throughout the country. Vast numbers of people flocked to hear the mysterious and wonderful machine that recorded and reproduced the human voice, music, and other sounds. The royalties were large. In Boston alone, \$1800 a week was collected on one occasion.

The wildest accounts of the phonograph were printed in both the American and European newspapers, but the palm for imaginative mendacity must be awarded to the "Figaro," of Paris. "It should be understood," said the author of that extraordinary specimen of journalism, "that Mr. Edison does

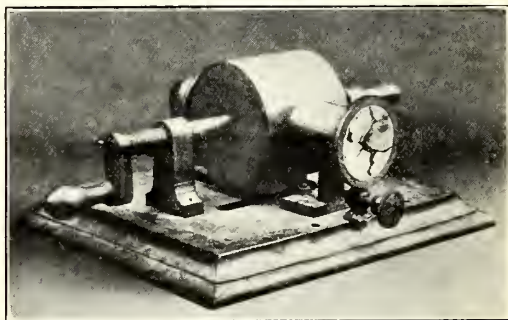

THE ORIGINAL EDISON PHONOGRAPH, NOW IN SOUTH KENSINGTON MUSEUM, LONDON

not belong to himself. He is owned by the telegraph company, which lodges him in a superb New York house, maintains him in luxurious style, and pays him a huge salary, so as to profit by his discoveries exclusively. The company employs men who never leave Edison for a moment—at table, on the street, in the laboratory. Hence this wretched man, guarded more closely than any criminal, can not devote a moment's thought to himself." Then followed a description of Edison's "Aërophone," a description which would have done credit to a Jules Verne. "You speak to a jet of vapor," the readers were told, and "your voice is carried for a mile and a half."

France recovered its poise when the phonograph was exhibited before the Academy of Sciences on March 11, 1878, by Count du Moncel. At the request of the count, Edison's French licensee Puskas seated himself in front of the phonograph and spoke into the mouthpiece in his best American-French: "The phonograph is highly honored at being presented to the Academy of Sciences." The chairman demanded silence. Puskas fitted a large pasteboard horn to the reproducer, and then, to the great astonish-



ment of the audience, the phonograph expressed its pleasure at being introduced to the Academy in Puskas' rather nasal American-French. A member of the Academy refused to believe his eyes and ears. "There is some trickery about this," he said. "A machine can't reproduce an accent. This is simply a piece of ventriloquism." Du Moncel then took his seat at the phonograph and said in his best Parisian French: "We thank Mr. Edison for having sent us his phonograph." Du Moncel's words were repeated in all their Parisian purity, and the skeptic was convinced.

Public interest in Europe and America was maintained only for about a year and a half. The phonograph with the tin-foil

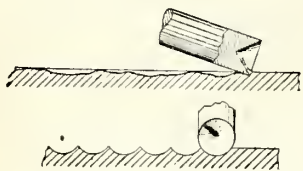

THE RECORDING TOOL, PROFILE AND END VIEWS

record was largely an exhibition machine. Its sale could be but limited, at best, because it was not easily operated by hand. In the meantime, Edison had begun his experiments on the electric light, and did not take up the improvement of the phonograph for nine years.

#### EDISON RESUMES WORK ON THE PHONOGRAPH

AFTER nine years of intense application to the invention of the electric incandescent lamp and his electric-light system, Edison resumed work on the phonograph in 1887. He entirely changed the mechanism, in order to employ a cylindrical wax record, and thus created a more practical type of phonograph, which could be used by every one. It was about this time that his laboratory at Orange, New Jersey, was completed, his plans including a factory in which the improved instrument was to be manufactured in large quantities.

Edison realized that exact uniformity of speed is essential to record and reproduce speech and music satisfactorily, and that a hand-operated phonograph could not, therefore, become a commercial success. He invented a mechanism that could be operated mechanically at a given, regular speed.

This second type of phonograph was at first equipped with a battery-driven electric

motor, which rotated the cylinder, but the electric motor was afterwards superseded by a clock-spring motor of the type now used in all phonographs and talking-machines. As a material for the records, tin-foil was entirely abandoned, and in its place a cylinder of wax, or waxlike material, was decided upon.

In the early stages of development, Edison experimented with paper cylinders covered with paraffin or other waxlike materials. Here, however, he found himself following in the footsteps of two other inventors, Chichester A. Bell and Charles Sumner Tainter, two Washington men who had been working on the phonograph during the time that Edison was so intensely busy with his electric light. A patent had been issued to Bell and Tainter on a cylindrical record-blank made of paper coated with certain combinations of wax, and they had also patented various other improvements.

About this time a corporation called The American Graphophone Company was formed by some Philadelphia capitalists to exploit the Bell and Tainter patents. This company equipped a factory and entered upon the manufacture of talking-machines and of wax-covered paper cylinder records.

Edison's exhaustive experiments with wax-covered paper cylinders had convinced him that the waxy material must be comparatively hard. But here he encountered a difficulty. If the paper cylinder was coated with hard wax, it would not, as the temperature of a room rose or fell, expand and contract at the same rate as the paper cylinder itself. Either the paper cylinder would warp, or the wax coating would crack. Therefore, he abandoned this plan and came to the conclusion that a cylinder must be made entirely of wax.

#### THE DEVELOPMENT OF THE WAX RECORD

To this end he instituted a long series of experiments in the development of a perfect all-wax cylinder. At one time he did not leave his laboratory for five days and nights. His laboratory note-books of this period disclose the vast amount of work that he did in making up and testing innumerable combinations of waxy materials obtained from all parts of the world. Progress was slow, but sure. Difficulties were eliminated one by one, and gradually a successful all-wax record-blank was evolved.

There were other problems to be solved.

The record on wax was gouged out by a small metal chisel fixed to the diaphragm, and the reproducer was equipped with a similar chisel. The chisel proved to be unsatisfactory. After having been reproduced a few times, records were practically unintelligible, because parts of the sound-waves were cut away. Moreover, the chisel could not satisfactorily record or reproduce hissing sounds, such as words in which the letter "s" appeared. Edison determined to remedy the defect, and began the most patient and persistent series of experiments that he ever conducted. For eight long months he experimented in thousands of ways to record and reproduce such words as sugar, scissors, specie, etc., and at last succeeded. At the same time he obtained perfect articulation.

The new method of recording depended on the utilization of a minute and peculiarly shaped sapphire for engraving sound vibration in a groove of the wax cylinder. Another sapphire served for reproduction, but a sapphire which could not cut the record, because it had a ball-shaped tip. The recording tool is shown in the illustration on page 696, in profile and end-on.

#### THE ATTEMPT TO USE THE PHONOGRAPH FOR DICTATION

DURING this period of inventive and development work, a corporation called the North American Phonograph Company had been formed by Philadelphia capitalists, who aimed to exploit the phonograph for general business dictation. After having vainly tried to introduce wax-coated paper cylinders, made in accordance with the Bell and Tainter patents, the company negotiated with Edison for the right to use his all-wax cylinders.

The phonograph at that time had not been developed to the point where it could supply the place of a stenographer. The company's predestined failure was hastened by the death of its chief promoter, and Edison, being the principal creditor, took back his phonograph patents. He organized the National Phonograph Company, and decided to concentrate his energies on the recording and reproduction of music. He reorganized his factories, equipped them with new machinery and tools, and proceeded to exploit a field in which he has ever since occupied a prominent position.

It was impossible to think of selling original musical records to the public. One record made by a first-class artist might

cost several hundred dollars. Clearly, some method had to be invented of duplicating the original precious record—some method comparable with printing a newspaper from type.

#### DUPLICATING THE ORIGINAL, OR MASTER, RECORD

THIS problem presented great difficulties, for the sound-waves cut in the surface of the wax were only one thousandth of an inch



EDISON AND HIS PHONOGRAPH. PHOTOGRAPH TAKEN IN 1878

deep, or about the thickness of tissue-paper. The millions of microscopic waves in a record must be duplicated so as to be absolutely identical with their originals and be free from false vibrations and other defects. Obviously, wax duplicates could not be made from a wax original or "master." So it became necessary to discover other means. After a vast amount of experiment, Edison succeeded in electroplating a metallic "sub-master," or matrix, from the original. Into this matrix, melted wax was poured. The resultant wax casting was an exact duplicate of the original.

Even more remarkable was another method of duplicating the original, or master, evolved by Edison. In a chamber from which the air was exhausted, he revolved the master between two leaves of gold, which was electrically vaporized. The gold vapor was deposited on the wax master in the form



of a film about one eight-hundred-thousandth of an inch thick. It would take eight hundred such films to form a pile as thick as a sheet of the finest tissue-paper. Upon such a gold film a heavy backing of baser metal was electroplated, and thus a substantial mold or matrix was made.

The second type of phonograph, with wax cylinder records carrying music, was brought out about 1888 and found a music-hungry world awaiting for it. Up to that time the phonograph was not available for the general public. Only a comparatively few people had ever seen or heard it; for the old tin-foil instrument had been used only for exhibition. The factories were humming day and night for years to fill the great demand for the improved phonograph.

#### THE INVENTION OF THE DISK RECORD

EMIL BERLINER, a German who had emigrated to this country, and who played a conspicuous part in the development of the telephone, devised a method of making records which was somewhat different from Edison's and which depended on the use of disks. Edison made his sound records by causing the engraving tool to rise and fall, for which reason his method is technically known as the "hill-and-dale." Berliner, on the other hand, thought it would be better to cause the tool to swing from side to side in the groove, for which reason a disk was more serviceable than a cylinder. Because the tool is moved from side to side, Berliner records are called "lateral cut." Berliner's way of making the master record was also different. Instead of using an all-wax plate, he employed a disk of zinc, covered with wax. The music was recorded on this wax surface, making its characteristic indentations, and then acid was applied which etched the record on the zinc, thus making a metallic master from which impressions could be taken.

The results, so far as the reproduction of music was concerned, were far from satisfactory when these records were played on a crude instrument designed for the purpose; and after experimenting for some time, Berliner felt that he needed the help of a more expert mechanic than himself. He took his crude machine and disk records to a little machine-shop in Camden, New Jersey, owned and operated by Eldridge R. Johnson, and left it there for certain repairs and changes to be made. After he had left the

shop, Johnson made a study of the device and soon realized its great possibilities. The farther he progressed with his study, the more enthusiastic he became. He joined forces with Berliner, and proceeded to make the needed improvements and refinements in the machine and records until at last he had completed a model of the familiar disk type of talking-machine. This was the beginning of the Victor Talking Machine Company, of which Mr. Johnson is the President and has been the directing spirit to this day.

These events occurred about 1896 or 1897. In the meanwhile, Edison had sold upward of one and a half million cylinder phonographs and more than a hundred million of the cylindrical records. Although he had no difficulty in selling cylinders, the demand for disks was insistent, probably because of the records which many great artists had made on disks. Accordingly, about 1907 or 1908, he began a series of experiments which were to end in the production of a "hill-and-dale" disk record; for to the hill-and-dale method of recording Edison had been wedded from the beginning. His earliest patents had been granted for disk records, and he was but reverting to original ideas. After an immense amount of experiment, his disk phonograph was completed and put on the market.

#### HOW RECORDS ARE MADE FOR THE PUBLIC

ALTHOUGH the principle of the phonograph is now well-known, the art of making records is deliberately shrouded in mystery, much of it ridiculously unnecessary. The particular composition of the waxlike master employed by a manufacturer is kept a profound secret. Few outsiders are permitted to see even the making of a record—certainly no one connected with a rival company. The proceeding is complex and calls for much skill, technical knowledge, and experience.

Imagine a great tenor, a popular operatic idol, about to immortalize his rendering of Verdi's "Celeste Aida." Before him is the mouth of a horn; behind him the orchestra. Even he does not see the actual recording equipment; for the small end of the horn is located either behind a curtain or a partition. The musicians are poised between heaven and earth, for some of them sit on shelllike benches, so that their heads are not far from the ceiling. So cramped are the quarters

that often they assume positions at which concert-goers would gasp in amazement. For example, the trombonists sometimes turn their backs to the conductor; they follow him by keeping their eyes glued on mirrors, by which his expressive beating of time is reflected. The loud instruments—the ponderous brasses—are always placed in the rear, so that their metallic blare may not

knew that he may have tried more than once to produce just the effect that he had in mind when he sang a particularly soul-stirring phrase.

The original record thus made, the wax master is turned over to the factory to be duplicated a thousandfold, even a millionfold. First a metallic matrix is made, called the master mold, and from this other

matrices are electroplated until there have been obtained a number of matrices, called working molds, which are used in printing the records offered for sale. The processes for making these various molds are intricate and are carried out by skilful men; the slightest scratch or the tiniest particle of dirt may unfit the mold for use.

Thus "Celeste Aida" or the latest dance-music reaches the backwoodsman or the Fifth Avenue mansion. Trills and roulades, have been disembodied from a perishable person-



MAKING A RECORD AT THE RECORDING STUDIO

drown out the finer tone of the strings, which are always to be found in front. The tenor soars up to his high notes directly into the yawning mouth of the horn. He gives his full-throated best; for he knows not only that his rendition of "Celeste Aida" will be heard by thousands, perhaps by millions, but that the luscious top notes, upon which his reputation hangs, will be compared with the equally luscious top notes of other tenors who have sung "Celeste Aida" into the phonograph before him, and who will sing it into a recording horn years after he is dead. A mistake—and the record must be made over again. Therein the tenor has an advantage denied him when he appears in public. The purchasers of his record never

personality; countless million puffs of air have been solidified, so that they can be transported to Alaska or Zanzibar. It seems like a miracle even now, when the strains of music made in some American seaboard town are heard all over the world, when mere recorded sound is as much an article of commerce as a barrel of sugar. Languages are taught. The speech of Indian tribes about to become extinct has been preserved. The musical and dramatic interpretations of great artists have been preserved for future generations, and great violinists, prima donnas, symphony orchestras, vaudeville singers, gladden not only audiences in great cities, but farmers on lonely acres and sailors on lonely seas.

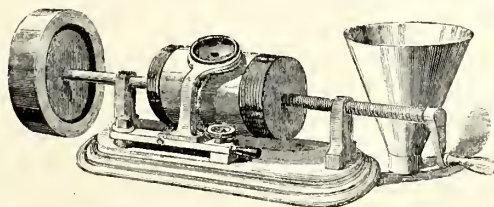

"EDISON'S SPEAKING PHONOGRAPH," FROM "SCRIBNER'S MONTHLY" OF APRIL, 1878



# THE JADE NECKLACE

By CAPTAIN JOHN M. ELLICOTT, U. S. N.

AN American war-ship had arrived in Shanghai on an important diplomatic mission, but this in no way concerned or interested Juan de la Rosa, the little Filipino lad who had enlisted as a mess-boy at Manila, and, by faithful service, had risen to be cabin-boy for the captain of the ship. So while the captain was visiting an up-river city on his mission of state, Juan was at liberty to search the shops and bazaars on shore for some beautiful gift for his sweetheart in Manila. Juan deeply loved his little sweetheart, and had saved all his money to buy her a costly present in token of the greatness of his love.

And so one day, in an out-of-the-way shop of the native city, Juan discovered a rare and wonderful jade necklace. It took nearly his last yen to buy it; but as soon as he saw it, he knew that nothing else would do, and he brought the precious trinket back to the ship and hid it away in his ditty-box in the cabin pantry, letting no one see it.

Meantime, the captain completed his diplomatic mission and cabled home the result in cipher, believing that it would be regarded as highly successful; but a change in administration in Washington had brought with it a change of policy, and the captain's reward was summary detachment from his ship, with orders to turn over the command of her to the next officer junior to him and to return immediately home.

Now all the ship's company loved their captain, and Juan de la Rosa's affection for him was almost adoration. Juan wept in secret as he packed his captain's trunks and saw them transferred to a mail-steamer about to sail, and his heart ached as if it would break.

"I want to give my captain a present," he said to a shipmate; "something he will always remember me by."

"But the navy regulations will not allow him to accept it," the shipmate replied. "You would place him in danger of court martial."

So, the night before the captain left, after Juan had served him dinner in the almost empty cabin, the little fellow sat alone on his ditty-box in the pantry with his head in his hands, striving to think of some way to

show his love and sorrow. All the days of kindness which he had known in that cabin, in many ports throughout the Orient, came back to him, and presently he remembered an occasion when the captain's daughter had been on board, and how gentle and beautiful she was, and how kind to him, and how her sweetness of manner had somehow reminded him of his sweetheart in Manila.

Then came the thought: they could not punish his captain for a gift accepted for his daughter. Was there not something among the curios in Juan's ditty-box which he could offer for her?

Juan locked the pantry door and carefully unpacked the small wooden box, laying aside his toilet articles and sweetheart's letters and picture, until he came to his trinkets near the bottom, and there lay the jade necklace.

Juan stood for a long time with the necklace in his hand looking at his sweetheart's picture. Then he closed his eyes and the saddened face of his captain, as he had sat alone at dinner that night, arose as a vision, and with it the beautiful face of his daughter.

"I will give my captain this necklace for his daughter," Juan said to himself. "Perhaps some day I can get another for Antonia."

Then Juan was overcome with a great bashfulness. He had not the nerve to offer his gift in person; if it were refused it would break his heart. Then he wrote this little note and tied it to the necklace:

Dear Captain:

I give you this for your daughter because I know I can not give any thing to you and because I love you and am very sorry you are going to leave, and this is the only way I can show you.

I love God and will pray every day that I may meet you again,

Good-by, my Captain, from

JUAN DE LA ROSA.

Next day Juan carried his present concealed about him and strove to get up courage enough to offer it, but at last his captain had taken the little fellow's trembling hand in a squeezing grip of farewell and gone on deck to go to the mail-steamer; and still the necklace remained in the bosom of Juan's blouse, so the poor boy rushed back into the pantry and burst into tears. Then a strong voice reached him through a skylight:

"Wait just a moment," he heard his captain say; "I'll go down and take one last look around the cabin to make sure I've left nothing."

Juan's heart gave a bound of gladness. Quickly he slipped into the cabin and laid

gazed around, then stepped to the table and picked up and read the crudely penciled note. Tears filled his eyes and he shook his head.

"I can't take it," he murmured, "even for my little daughter; it is too valuable."

But after a pause of perplexity he placed the note and the necklace in his pocket and exclaimed:

"Yes, I will. I understand, little Juan. It would break your heart if I did n't. God bless you!" And he hastily returned to the deck and to his waiting boat.

The new officer who had taken command gave a big dinner that evening in the cabin, which was now his, to many foreign officials and their wives; and when the table was cleared and the servants had departed, the conversation quite naturally turned to Oriental curios and jewelry.

"I think I have been lucky enough to secure one of the rarest things to be found in Shanghai," a young lieutenant remarked. "I got it in an out-of-the-way shop where tourists would scarcely think of going. It is an old-fashioned jade necklace. I'll show it to you." And he brought the precious trinket from his state-room and laid it before them on the center-table.

"Ah! to think that you got that!" exclaimed the wife of a foreign consul; "and I've been searching Shanghai for two years to find one. I would have given any price for it. Oh, this is maddening—maddening!"

"Yes," the lieutenant replied. "I only discovered it yesterday, and the old dealer



"THERE ON THE TABLE JUAN SAW—THE JADE NECKLACE!" (SEE NEXT PAGE)

his gift and note on the familiar center-table, then fled away through many alleyways to a far part of the ship and concealed himself, for fear he might be sent for and asked to take his present back.

The captain reëntered his cabin alone and



said I could not now find another like it in Shanghai."

The evening had waned and the party was even then getting into wraps preparatory to departure. A few moments later all went on deck and lingered there in the soft night air saying their good-bys.

Juan de la Rosa had not served in the cabin that evening. He had got liberty early in the afternoon and gone ashore to divert his mind from his sorrow. Returning just after the departure of the guests, and while the officers from whom they had parted were still chatting among themselves on deck, Juan slipped into the cabin to lay out night clothing for his new master, and there on the table saw—the jade necklace!

As he stood and gazed upon it, he felt the love for his former captain, which had been surging through him all day, slowly freezing up, and a fierce reproach and indignation taking its place. He took the necklace out into the pantry and once more concealed it in the bottom of his ditty-box. Then he fled away to his hammock in a far part of the ship to suffer in secret.

Next morning, the lieutenant who had displayed the necklace was in confidential conversation with the new captain behind closed doors.

"Yes," the new commander said, "we returned almost immediately, and it was gone. And no one had been in here, for I had long since dismissed the servants, and the cabin-boy was ashore on liberty. I know he had not returned, for my pajamas had not been laid out. The cabin orderly was, of course, on deck with me. The whole thing is clear to me, Norton. You remember how Madame M—— raved over the necklace and her inability to get one, and we all know what they whisper about her on shore. Yet for diplomacy's sake, such a thing must remain unthinkable. It 's horribly unfortunate, but we must keep this locked in our breasts and you must grin and bear it."

More than a year passed. The war-ship never returned to Manila, but finally arrived in San Francisco; and the day following her arrival, she was subjected to the usual customs inspection. All the members of the crew were lined up on deck in their respective divisions, with their ditty-boxes and all other packages containing dutiable articles in front of them. The customs officials passed down the ranks, accompanied by the commanding officer of the ship and the officer commanding each successive division.

Juan's division was commanded by Lieutenant Norton.

"Where did you get that?" exclaimed both the captain and the lieutenant in astonishment as the customs officer drew forth from Juan's ditty-box a jade necklace.

"I bought it in Shanghai; it is mine. I bought it for my sweetheart in Manila, but we never went back."

In a few moments Juan was under arrest, and next day underwent a grilling examination by the captain, but not another thing would he tell. Never would he admit that he had offered his precious necklace to that other captain he had loved so much, as the highest token of his affection, and the latter had rejected it. Proud little Juan knew that he would die sooner than do this.

"Very well," said his questioner, "you are telling me falsehoods. You will be tried by a general court martial for theft."

So Juan de la Rosa was taken from the war-ship and placed in prison at the near-by Navy Yard awaiting trial; and for many weeks the poor little fellow remained behind prison bars, until his case came up; but never a thing would he tell, even to the counsel assigned to defend him, except that he had bought the necklace at a certain place in Shanghai for his sweetheart in Manila and had kept it in his ditty-box until such time as he could give it to her in person.

SEVEN solemn officers were gathered around the long court-room table at the Navy Yard. The judge-advocate briskly arranged his papers, the stenographer took his seat, and the first case of the day was called. The president of the court gave a start of surprise as Juan de la Rosa, sickly pale, but with proud, flashing eyes, was ushered in as the accused.

The judge-advocate rapidly read the precept; then he turned to the prisoner and said, "Have you any objection to being tried by any members of the court?"

Juan's eyes swept slowly and hopelessly over the unfamiliar faces, then rested long upon the president—his once much-loved captain! For a moment Juan seemed about to speak, to make some appeal; then he replied stolidly and hopelessly: "None."

The solemn oath to "well and truly try" was then administered. The court was cleared, and the specification and charge of theft were carefully examined and found to be in due form; yet the president shook his head in perplexity.

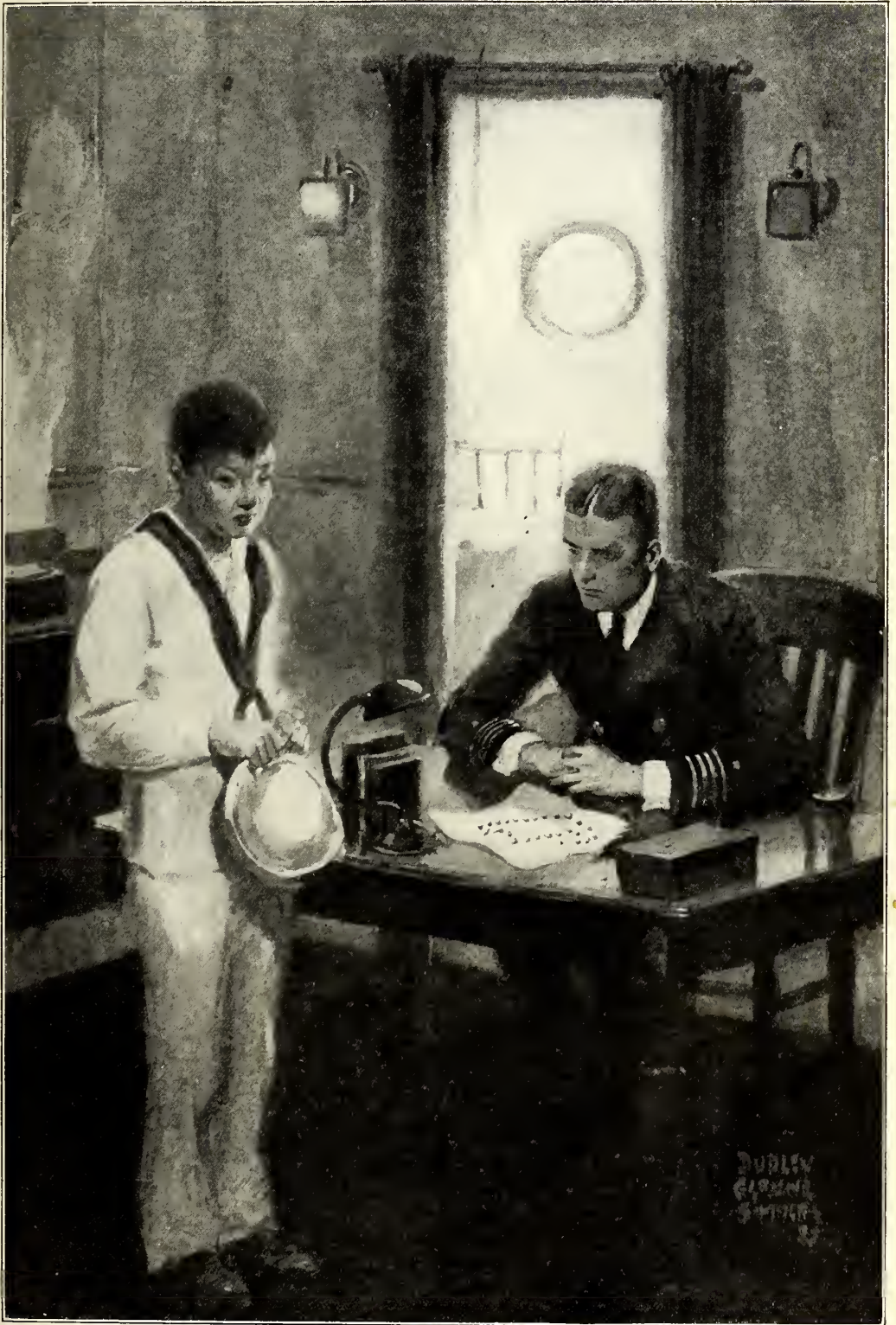

"THE NEXT DAY JUAN UNDERWENT A GRILLING EXAMINATION BY THE CAPTAIN"



"There is some mystery here," he said; "but perhaps we can unravel it as the trial goes on."

The court was opened and Juan was arraigned. Proudly and firmly he pleaded, "Not guilty"; but as witness after witness took the stand against him, the net of circumstantial evidence was drawn tighter and tighter, until it seemed, even to his counsel, that he was completely enmeshed.

The defense could only offer some witnesses who testified in a half-hearted way as to Juan's previous good character.

Then the little fellow was asked if he would take the stand in his own behalf, but he said stolidly, "No." When told that he could make a statement to the court, he only reiterated what he had said when he had been questioned before.

During the trial, the president had sent an orderly away, with a note, and he had returned with a package which he placed in the president's hand. Slowly the latter unwrapped it, as Juan concluded his statement, and laid upon the table another jade necklace, exactly like the one in evidence.

The expression of hopeless defiance upon Juan's face gave place first to amazement, and then to a gladness which was apparent to every one present.

Quickly, and without restraint from any one on the astonished court, he took the two necklaces in his hands and compared their

complete resemblance link by link. Not until he had finished and looked again into his captain's eyes with the old look of adoration, did the latter speak:

"Juan, *won't* you tell the court more about your necklace?"

"Yes, my captain. Now I'll tell everything."

"Will you take the stand and do so under oath?"

"Yes, very gladly."

It was not hard, after that, for the court to unravel the tangled skein and record its acquittal, though none but the president fully understood the sentiment which had kept Juan's lips so firmly sealed.

When the trial was finished, Juan was detained in the anteroom, and presently found himself confronted by the president of the court and his accuser, each holding in his hand a jade necklace.

"Juan," said the former, "this is my first opportunity to thank you for my daughter's beautiful present, and I do so from the bottom of my heart."

"And, Juan," said Lieutenant Norton, "I ask you to forgive me for the blunder which has caused you so much distress, and, as amends for it all I wish you to present this necklace to your sweetheart in Manila."

To which little Juan replied with tear-filled eyes:

"I thank you; I thank you both; I am very happy."

---

## "WHEN PIPES OF PAN ARE BLOWING"

OVER the hills I hear them calling,—  
The pipes of Pan, so thin and clear,—  
Sweet and low, like a wood-bird's fluting  
That only I can hear.

Or is it the wind in pine tops sighing,  
Like the voice of a far-off sea?  
Or is it the sound of the silver raindrops  
That I hear calling me?

It is the voice of April calling—  
The note of Spring, so soft and low,  
That I hear when pipes of Pan are blowing,  
Calling, and I must go.

Where April, in robes of green is walking,  
And joy-mad linnets sing,  
I must follow, follow the wild pipes' music  
And dance at the gates of Spring!

Edith D. Osborne.



# Queen

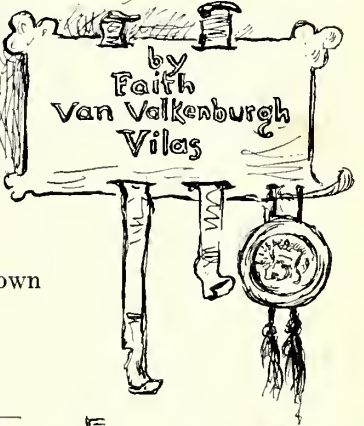

MY mother made a pasteboard crown  
With points, to fit my head,  
And then she crayoned jewels on  
In green and blue and red.

She let me wear her flow'ry dress,—  
It 's sweet as sweet can be,—  
In which she used to make believe,  
When she was small like me.

And then she found a long pink veil  
And pinned it to my crown;  
I saw it follow on the floor  
Whenever I looked down.

I marched about the living-room  
All traily-proud and slow,  
While Mother played a queen's own song,  
So dignified and low.

I sat upon my throne awhile  
Quite haughtily and grand,  
And ruled my dolls that stood about  
On squares in Carpet-land.

When I grew sleepy, Mother dear  
Just sat and held me tight;  
A queen is fun for daytimes, but  
I 'm glad I 'm me at night.





# THE TURNER TWINS

By RALPH HENRY BARBOUR

## SYNOPSIS OF PREVIOUS INSTALMENTS

NED and Laurie Turner, twins, enter Hillman's School in the autumn. Deciding that it is their duty to take part in sports, although neither has had experience, Ned joins the football candidates and Laurie takes up baseball. Ned's gridiron education is aided by "Kewpie" Proudree, who teaches him kicking; and by hard work, Ned secures a place on the scrub team. At a meeting held to devise methods of replenishing the football treasury, Ned suggests raising money by an outdoor fête, and is made one of a committee to take charge. He enlists the aid of Laurie and then that of Polly Deane and her chum, Mae Ferrand. Polly is the daughter of the Widow Deane, who keeps the little tuck-shop patronized by the students, and between her and the twins a firm friendship has grown up. Mr. Starling, whose son Bob is a day-pupil at Hillman's, offers his garden for the affair. Ned asks the girls to take charge of two of the booths at the fête, and to find others among their friends to look after the rest, and they agree to do so.

## CHAPTER XIII

### NED GETS INTO THE GAME

FOUR hectic days followed. To Laurie, since Ned was held for two hours each afternoon at the football field, fell most of the duties of the Committee on Arrangements, and he was a very busy youth. He badgered shopkeepers into parting with goods to be sold at the booths, helped Bob Starling trim up the old arbor in the garden of the Coventry place, made frequent trips to the Orstead caterer's, engaged eight cakes from Miss Comfort and twelve dozen cream-puffs from the Widow Deane, spent two hours Wednesday helping Lew and Hal Pringle distribute posters throughout the village, and attended to a hundred other matters between times. Of course, Ned aided when he could, and was helpful with advice and unflinching in suggestions; but recitations and football practice did not leave him much time, even though he conscientiously arose a full hour earlier every morning that week, and skimped studying so much that he got in trouble with three instructors in one day!

Miss Tabitha had proved as helpful as Dan Whipple had predicted. She had shaken her head at the idea of entertaining six hundred at the fête. "You must not count on more than half that many," she said. "I dare say all the boys will go, and they'll make ninety. Then, if you get two hundred of the townfolk, you'll be doing very nicely. Don't decide how much salad or how many sandwiches you want until Saturday morning. So much will depend on the weather. Even if you hold the affair indoors, lots of folks won't come if it rains. You say you've ordered eight cakes from Martha Comfort and twelve dozen cream-puffs from Mrs. Deane?"

"Yes 'm," said Ned. "We wanted Mrs. Deane to make more, but she did not think she could."

"Well, that's a hundred and forty-four cream-puffs, and—let me see—one of Miss Comfort's cakes will cut into sixteen pieces, and eight times sixteen—"

"A hundred and twenty-eight, ma'am."

"Well, and a hundred and twenty-eight and a hundred and forty-four—"

"Two hundred and seventy-two."

"You're real quick at figures, are not you? Seems as if, though, counting on three hundred, you'd be a little short. I'll have Aunt Persis make one of her marble-cakes. That'll help out, I guess."

"Yes 'm; thanks awfully," answered Ned.

"Who is going to serve the refreshments?"

"Why—why—" Ned's face lengthened. "I guess we had not thought of that!"

"Well, it makes a heap of difference, because you can make a quart of ice-cream serve ten people or twenty, just as you've a mind to. I usually count on sixteen. Same way with a loaf of cake, and same way with salad. It's awfully easy to waste salad when you're serving it. Now, if you'd like me to, Ned, I'll attend to serving everything for you. You just have the things set down there and I'll look after them."

"Oh, Miss Hillman, if you would! Gee, that would be great! It—it'll be a lot of trouble, though, ma'am."

"Well, I guess it won't be the first trouble I've seen," replied Miss Tabitha, dryly; "nor it won't be the last!"

Thursday afternoon Laurie hurried over to the Coventry place as soon as a two o'clock recitation was done. Bob was awaiting him at the gate, and conducted him around to the back of the big square house. Ned stared in surprise. The tangle of trees and vines and shrubbery had been

trimmed to orderly neatness, the long, unkempt grass had been shorn to a yellow, but respectable, turf, and the old arbor showed new strips where Thomas, the Starling's man, had been at work on the decrepit frame. Near at hand lay piles of cedar and hemlock branches.

"Dad got a couple of the men to cut those down near the tunnel and haul them up here," Bob explained. "Thomas is going to help us put them up. He made a peachy job of the garden, did n't he?"

"You bet!" responded Laurie, heartily. "I would n't have known the place! I say, Bob, this arbor's longer than I thought it was."

"Forty feet, about. Why?"

"I only ordered six tables and a dozen chairs from the caterer," answered Laurie, dubiously. "Guess they are n't enough; but he's charging twenty-five cents apiece for them—"

"Twenty-five cents for a table? Is n't that dirt-cheap?"

"We're only renting them, you idiot!"

"Oh, I see. Well, six is enough, I guess; you don't want to crowd them. Now let's get busy with the green stuff. I'll yell down cellar for Thomas. There's a ball of twine, and I've got two hammers and a lot of tacks on the side porch. You take your coat off and I'll—"

"We'll have to have a step-ladder, Bob!"

"There's a short ladder right beside you. Be right back."

Laurie sat down on a wheelbarrow, after removing his coat and folding back the sleeves of his shirt, and looked around him. The garden was fairly large—larger in appearance since the clutter of shrubbery along the sides had been cleared away. Along the School Park edge ran a tall hedge of lilac bushes. At the back was the high board fence, painted dark brown, that separated the garden from the Widow Deane's humble property. On the other side was a rusty ornamental iron fence, mostly hidden by vines. Broad walks, in spite of Thomas's efforts rather overrun with weeds, surrounded the central plot of ancient turf, and another ran straight down the middle of the garden, connecting with the arbor. Wires were to be strung from the trees and across to the arbor, and Chinese lanterns hung thereon. Laurie, half closing his eyes, sought to visualize the place as it would appear on Saturday. He did want the affair to be a success, both financial and

artistic, both on account of the school and—well, for the honor of the Turners! While he was musing, two things happened simultaneously: Bob and Thomas appeared from



"WHAT IS BROWN'S COLOR?" "WHY, BROWN, OF COURSE!"

the house, and a familiar voice came to him from the opposite direction.

"Nod!" called the voice. "Nod, will you please come here a moment?"

Laurie's eyes sought the board fence. Over the top of it appeared the head and shoulders of Polly. He left the wheelbarrow and hurried through the arbor and down the walk beyond. Polly's face indicated distress, whether mental or physical Laurie could n't determine. But Polly's first words explained.

"I can't stay here l-long," she said. "I—I'm just hanging by my elbows. I climbed up on a board, and it's fallen down!"



"I'll get you a ladder!" cried Laurie, gallantly.

"N-no, never mind. I'm going to drop in a s-second. I just want to ask you what Brown's color is. Nettie Blanchard is going to be Brown and—"

"Why, brown, of course!"

"Oh!" There was the sound of desperate scraping against the farther side of the fence, and Polly's countenance became fairly convulsed with the effort of holding herself in sight. "Oh! She said it was pur—pur—"

Polly disappeared. There was a thud from the next yard.

"Purple!" The word floated across to him, muffled but triumphant.

"Are you hurt, Polly?" he called anxiously.

"Not a bit," was the rueful response; "but I'm afraid the day-lilies are!" Then she laughed merrily. "Thanks, Nod! I did n't think Nettie was right. She loves purple, you see!"

"Does she? Well, say, maybe she can be Williams. We were n't going to have Williams, but its color is purple, I think, and if she is going to be disappointed—"

"She will look very well indeed in brown," came from the other side in judicial tones; "and if we begin making changes, half the girls will want to be something they are n't. Why, Pearl Fayles begged to be some girls' college neither Mae nor I had ever heard of, just so she could wear lavender and pale lemon!"

"Well, all right," laughed Laurie. "She'd better stick to Brown—and brown! Good-by, Polly. I'll drop in after a while and find out how things are getting on."

He turned to find Bob viewing him quizzically from the end of the arbor, swinging a hammer in each hand. "Of course it's all right, I dare say," he announced, "but I *thought* you came here to fix up the arbor. Instead of that I find you talking to girls over the fence!"

"There's only one girl," replied Laurie, with dignity, "and we were talking business."

"Oh, of course! Sorry I interrupted."

"You need n't be, and you did n't. Quit grinning like a simpleton and give me a hammer!"

"Right-o! Come on, Thomas! It's quite all right now!"

An hour later their task was done, and well done, and they viewed it with approval. To be honest, the major part of the work had been performed by the faithful Thomas, although it is not to be denied that both

Laurie and Bob toiled conscientiously. Before they were through approving the result from the various angles, Bob's father joined them. Mr. Starling was an older edition of Bob—a tall, straight, lean-visaged man of forty-two or -three, with the complexion of one who had lived an outdoor life. He had a deep, pleasant voice and a quiet manner not fully in accord with a pair of keen eyes and a firm mouth.

"I'd call that a good piece of work, boys," he said, as he joined them. "And right up to specifications, too. Those paper lanterns come yet, Bob?"

"No, sir; I have n't seen them."

"Lanterns, Mr. Starling?" asked Laurie. "Do you mean Chinese lanterns? We've ordered a lot from the caterer, sir."

"Tell him you won't need them, then. I've got a hundred coming up from the city, Turner. They ought to be here, too. Thomas, call up the express company and ask about them."

"That's very kind, sir," said Laurie, "but you need n't have done it. You—you're doing *everything!*"

"Nonsense! Bob and I want to do our part, of course. Well, this wilderness certainly looks different, does n't it? That reminds me, Bob; the agent writes me that we may 'make such improvements to the property as we desire.' So, as I consider the absence of that arbor an improvement, I guess you can pull it down any time you like. I'm going to have a cup of tea, Turner. Will you join me? I believe there will be cakes, too."

Laurie found Ned in rather a low frame of mind when he got back to Number 16 a half-hour before supper-time. Ned was hunched over a Latin book and each hand held a firm grip on his hair. At Laurie's arrival he merely grunted.

"Where does it pain you most?" asked Laurie, solicitously, subsiding into a chair with a weary sigh. Ned's mood was far from flippant. He rewarded the other with a scowl, and bent his gaze on the book again. "Want to hear the latest news from the front?" persisted Laurie.

"No, I don't!" his brother growled. "I've had all the news I can stand. Smug says that if I don't get this rotten stuff by nine to-night, and make a perfect showing to-morrow, he will can me!"

"Mr. Cornish said that?" gasped Laurie. "What do you know about that? Why, I thought he was a gentleman!"

"He 's a—a brute! I can't learn the old stuff! And I have a hunch that Mulford means to give me a try in the Loring game Saturday. And if I don't get this, Cornish will fix it so I can't play. He as good as said so."

"Did n't you tell him you 'd been busy with the fête and everything?"

"Of course I did. Much he cared! Just made a rotten pun. Said I'd better keep my own fate in mind. Puns are fearfully low and vulgar!"

"Are n't they? How much of that have you got?"

"Six pages. I—I 've sort of neglected it the last two days. Some fellows can fake through, but I don't have any luck. He 's always picking on me."

Laurie whistled expressively. "Six pages! Well, never say die, partner. We 'll get down to supper early, and that 'll give us two hours before nine."

"Us?" questioned Ned, hopefully.

"Sure. I 'll give you a hand. As the well-known proverb so wisely remarks, two heads are the shortest way home."

Ned grinned, and stopped tormenting his hair. "Honest? That 's mighty decent, Laurie. I 'll do as much for you some day."

"Hope you won't have to. Wash your dirty face and let 's beat it!"

At half-past nine a more cheerful and much relieved Ned returned from the hall master's study. "All right," he announced to an anxious Laurie. "He was rather decent, too. Said he guessed that, in view of the manifold affairs engaging my attention just now,—you know the crazy way he talks,—he would n't demand too much from me. Reckon he means to let me down easy tomorrow, eh?"

"Maybe, partner, and maybe not. Take my advice and, in the words of the Scouts, be prepared!"

Friday was a hectic day for Laurie and all others concerned with the fête. Difficulties that had remained in ambush all the week sprang out and confronted them at the last moment. Half a dozen things had been forgotten, and every member of the committee sought to exonerate himself. Tempers were short and the meeting in Dan Whipple's room at nine o'clock was far from harmonious. All went to bed that night firmly convinced that the affair was doomed to be a flat failure. And, to add to that conviction, the night sky was overcast and an unsympathetic easterly wind was blowing.

Ned, conscious of having imposed too many duties on Laurie, was grouchy and silent; and Laurie, convinced that he had been made a "goat" of, and that Ned was secretly blaming him for mistakes and omissions that were no faults of his, retired in high dudgeon.

And yet, the morning dawned fair and warm, with an almost cloudless blue sky over the world, and life looked very different indeed. Ned arose whistling, and Laurie somehow knew that everything would be all right. Fortunately, they had but two recitations on Saturday, and in consequence there remained to them three whole hours before dinner to devote to the affairs of the entertainment. They were busy hours, you may be sure. If Ned hurried downtown once, he hurried there half a dozen times; while Laurie, seated beside the driver of a rickety express-wagon, rounded up all kinds of things, from the platform at the field-house to the cakes at Miss Comfort's. Dinner brought a respite; but as soon as it was over, Laurie was back on the job, while Ned joined the football players.

Of course, what the Hillman's School football team should have done that afternoon was to score a decisive victory over the visiting eleven. What it did do was to get thoroughly worsted. Loring was something of a surprise, with a heavier line and a faster bunch of backs than Hillman's had expected. And Loring knew a lot of football, and proved the fact early in the game. At half-past two, by which time the second period was half over, the result was a foregone conclusion. Loring had scored two touchdowns and as many goals therefrom, and the Blue had never once threatened the adversary's last white line. Gains through the opponent were infrequent and short, even Pope, who could generally be depended on to tear off a few yards when the worst came to the worst, failing dismally.

In midfield, Mason and Slavin made some stirring advances around the Loring wings, and there were several successful forward passes to the home team's credit; but once past Loring's thirty-yard line, Hillman's seemed powerless. The third quarter went scoreless, and in the fourth, realizing doubtless that defeat was certain, Coach Mulford used his substitutes lavishly. Ned made his first appearance on the big team in that period, taking Mason's place for some eight of the fifteen minutes. He did neither better nor worse than the other second- and third-string fellows, perhaps—although,



when Pope was taken out and Deering substituted at full-back, he did his share of the punting and performed very creditably. But that fourth period gave Loring an opportunity to add to her score, and she seized it. Even with several substitutes in her own line-up, she was still far better than Hillman's, and a goal from the field and, in the last few moments of the game, a third touchdown resulted.

The Blue fought desperately and gamely with her back to the wall, in an effort to stave off that last score; but eventually Holmes, who had taken Kewpie's place at center, weakened, and the Loring backs piled through. The final score was 23 to 0, and what two hours before had been looked on as a victory or, at the worst, a tie, had become a cataclysm! Humiliated, if not disgraced, the home-team players trailed to the field-house with hanging heads, averting their eyes from the sight of Loring's triumphant march around the gridiron.

## CHAPTER XIV

### THE FÊTE

BEHOLD Fairyland!

Well, at least an excellent imitation of what Fairyland must look like. Overhead, a clear, star-sprinkled sky; below, scores of gaily-hued lanterns shedding their soft glow over a charming scene. Through the side gate, please, on School Park. Twenty-five cents to the boy on duty there, and you are inside, with the manifold attractions awaiting you. On three sides of the transformed garden are the college booths, each decked with bunting and flags of appropriate colors, and each presided over by a patriotically attired young lady who will gladly, nay, eagerly, sell you almost anything from a cake of soap ("Donated by the Town Square Pharmacy, H. J. Congreve, Prop'r") to a knitted sweater or aingham house-dress ("Compliments of The New York Store, High Class Dry Goods"). Near at hand, Yale is represented by Miss Polly Deane, capped and aproned in blue, her eyes sparkling and her voice sweetly insistent: "Won't you buy something, please, sir? Post-cards, two for five! These pictures are only fifty cents, all beautifully framed and ready for hanging! Can I sell you something, ma'am?"

Beyond, gay with orange and black, is the Princeton booth; and still beyond, Dartmouth and Columbia and California, and

then, a blur of brilliant crimson through the leafage, Harvard. And so on all around the garden, with merry voices sounding above the chatter of the throng that moves here and there. Down the center of Fairyland runs a leafy tunnel from within which blue and red and yellow and green rays twinkle. There, under the hanging lanterns, little tables and chairs are dotted on the gravel, and half a dozen aproned youths are busy bearing, not always without mishap, plates of salad and rolls and dishes of ice-cream and cake. Close to the back of the house is a platform illumined by a row of electric lights, the one glaring spot in the area of soft radiance.

"How 's it going?" asked a heavily built youth of a slimmer one who had paused at the entrance to the arbor.

"Hello, Kewpie! Oh, dandy, so far. We took in eighty-four dollars this afternoon, and we 'll do at least twice as well to-night. They 're still coming. Have you seen Whipple anywhere?"

"Yes, a minute ago, down at the Pennsylvania booth. She 's a mighty pretty girl, too, Nod. I bought a pocket-knife for her for a quarter, and got stung; but I don't mind. I 'm going back to get another pretty soon. When do I have to sing again?"

"You follow Wilson's clog-dance. We 're switching you and Cheesman, Kewpie. His stuff is corking, but it 's pretty high-brow, and we thought you 'd better bring up the end and make the audience feel cheerful."

"All right; but it won't feel very cheerful if those orchestra guys don't do better than they did this afternoon. They were four or five notes behind me once! Nid said you had a new stunt this evening—something you left out this afternoon."

"Yes; we could n't work it in daylight very well. It ought to go fine to-night, though."

"What is it?"

"You wait and see. I 've got to find Whipple. Say, if you see Ned, tell him I 'll be at the platform in five minutes and want him to meet me there. Everybody keeps getting lost here!"

On the way past the arbor, Laurie ran into George Watson, returning across lots balancing a couple of plates in one hand and holding a large slab of cake in the other, from which he nibbled as he went. "Hello!" he said. "I 've been looking for you."

"Wanted to bring me refreshments, I suppose."

George looked at the empty plates, laughed, and shook his head. "Not exactly. I've been feeding Cornell. Somebody

Thanks. Want an ice-cream? I'll treat."

"No, thanks. Have you seen Dan Whipple wandering about anywhere?"

"Sure! He's over at the Pennsylvania booth, buying it out! Say, everything's going great, is n't it? Could n't have had a finer evening, either, what? Well, see you later. I'm hungry!" And George continued his way to the house, where Miss Tabitha, surrounded by willing and hungry helpers, presided sternly, but most capably, over the refreshments.

At eight o'clock the boy on duty at the entrance estimated the attendance as close to two hundred, which, added to the eighty-six paid admissions before supper, brought the total close to the first estimate of three hundred. It is safe to say that every Hillman's boy attended the fête either in the afternoon or evening, and that most of the faculty came and brought Mrs. Faculty—when there was a Mrs. Faculty. Doctor Hillman was spied by Laurie purchasing a particularly useless and unlovely article in burnt wood from the auburn-haired Miss Hatch. Every one seemed to be having a good time, and the only fly in the ointment of the committee was the likelihood that the refresh-

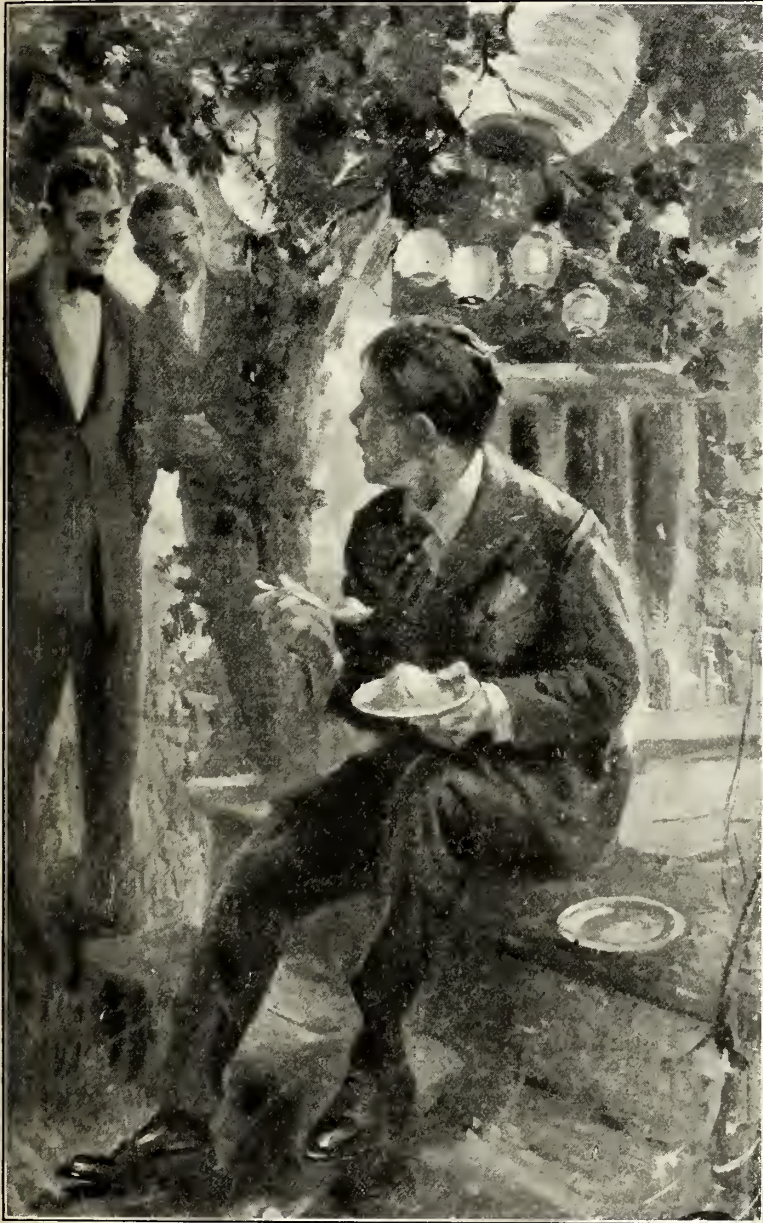

"KEWPIE WAS DISCOVERED CONSUMING HIS FOURTH PLATE OF ICE-CREAM"  
(SEE NEXT PAGE)

ought to take eats to those girls, Nod; they're starving!"

"All right; you do it."

"What do you think I am? A millionaire? I brought Mae a salad and an ice-cream. I'm about broke—lend me a half?

ments would be exhausted far too soon.

The Weather Man had kindly provided an evening of exceptional warmth, with scarcely enough breeze to sway the paper lanterns that glowed from end to end of the old garden, an evening so warm that ice-cream was more



in demand than sandwiches or salad; and fortunately so, since ice-cream was the one article of refreshment that could be and was replenished. If, said Ned, folks would stick to ice-cream and go light on the other refreshments, they might get through. To which Laurie agreed, and Ned hied him to the telephone and ordered another freezer sent up.

At a few minutes after eight the Banjo and Mandolin Club took possession of the chairs behind the platform and dashed into a military march. Following that, six picked members of the Gymnastic Club did some very clever work, and Cheesman, a tall and rather soulful-looking upper middler, sang two ballads very well indeed, and then, as an encore, quite took the joy out of life with "Suwanee River"! Little Miss Comfort, present through the courtesy of the Committee on Arrangements, sniffled quite audibly, but was heard to declare that "it was just too sweet for anything!" A rather embarrassed junior attempted some card tricks that did n't go very well, and then Wilson, garbed more or less in the character of an Irish gentleman returning from Donnybrook Fair, and swinging a shillalah, did some jig-dancing that was really clever and won much applause.

There was a brief unofficial intermission while three anxious committee members made search for Kewpie Proudtree. He was presently discovered consuming his fourth plate of ice-cream in the seclusion of the side porch, and was haled away, protesting, to the platform. In spite of what may seem an over-indulgence in refreshment, Kewpie was in excellent voice and a joyful mood, and sang four rollicking songs in a manner that captured his audience. In fact, long after Kewpie had vanished from the public gaze and returned to his ice-cream, the audience still demanded more.

Its attention was eventually captured, however, by Dan Whipple, who announced importantly that it gave him much pleasure to say that, at a great expense, the committee had secured as an added attraction the world-famed Signor Duodelli, who, with their kind permission, would exhibit for their pleasure and astoundment his miraculous act known as the Vanishing Man, as performed before the crowned heads of Europe, to the bewilderment and applause of all beholders. "Ladies and gentlemen, Signor Duodelli!"

The Signor had a noticeable likeness to

Lew Cooper, in spite of his gorgeous mustache and flowing robe of red and purple cheese-cloth. Yet it might not have been Lew, for his manner was extremely foreign and his gestures and the few words he used in directing the arrangement of his "properties" were unmistakably Latin. The properties consisted of a kitchen chair, a threefold screen covered with black baize, and a coil of rope. There was also in evidence a short wand, but the Signor held that in his hand, waving it around most eloquently. The audience laughed and applauded and waited patiently until the chair had been placed exactly to the Signor's liking, close to the back of the platform, and the screen beside it. Previously, several of the lights had been put out, and those that remained threw their glare on the front of the stage, leaving the back, while discernible, less in evidence.

"Now," announced the Signor, narrowly escaping from falling off the platform as he tripped over his robe, "I aska da some one coma up and giva da help. Any one I aska. You, Signor, maybe, eh?" The magician pointed his wand at Mr. Cornish, in the front of the clustered audience; but the gentleman laughingly declined. The Signor seemed disappointed. "No-o-o? You no geta da hurt. Some one else, eh?" He looked invitingly around, and a small junior, urged by his companions, struggled to the front. Unfortunately for his ambitions to pose in the limelight, the Signor's glance had moved to another quarter, and, ere the junior could get his attention, a volunteer appeared from the semi-obscurity of the kitchen porch. He was peculiarly attired, wearing a simple white garment, having a strong resemblance to the old-fashioned night-shirt, that covered him completely from neck to ankles. He was bareheaded, revealing the fact that his locks were red-brown in hue.

"Ah!" exclaimed the Signor, delightedly. "You will helpa me, si? Right thisa way, Signor. I thanka you!"

"That 's one of the Turner fellows," muttered a boy, while the small junior and his companions called "Fake!" loudly. However, the good-natured laughter of the audience drowned the accusation, and some two hundred pairs of eyes watched amusedly and expectantly while, with the assistance of two other volunteers, the youth in the white robe was tied securely to the chair.

"Maka him tight," directed the Signor, enthusiastically, waving his wand. "Pulla da knot. Ha, thata da way! Good!"

The two who had tied the victim to the chair retired from the platform. The Signor seized the screen and opened it wide and turned it around and closed it and turned it again.

"You see?" he demanded. "There is nothing that deceive! Now, then, I placea da screen so!" He folded it around the boy and the chair, leaving only the side away from the audience uncovered. He drew away the width of the platform, and, "Music, ifa you please," he requested. The orchestra, whose members had moved their chairs to one side, struck up a merry tune, and the Signor, folding his arms, bent a rapt gaze on the blank, impenetrable blackness of the screen. A brief moment

passed. Then the Signor bade the music cease, took a step forward, and pointed to the screen.

"Away!" he cried, and swung his arm in a half-circle, his body following with a weird flaring of his brilliant robes until, with outstretched finger, he faced the audience. "Ha! He come! Thisa way, Signor! Comea quick!"

As one man the audience turned and followed the pointing finger. Through the deserted arbor came a boy in a white garment. He pushed his way through the throng and jumped to the stage. As he did so, the Signor whisked aside the screen. There was the chair empty, and there was the rope dangling from it, twisted and knotted.

*(To be continued)*

---





stems from three to four feet high. Even in their ordinary growth of fifteen inches or so, these brodiaeas, with their cluster of lilac or purple blossoms on the tip of the single smooth green stalk, are among the most charming of our wild flowers; but to meet them on that stony desert hillside, grown to three times their usual height, so that they tapped me playfully on the waistcoat as I walked, seemed like enchantment.

However, one is more likely to be surprised at the shortness than the tallness of the desert annuals. You find, in cañons, little three-inch-high canterbury-bells bearing great blossoms half as long as themselves, and reminding you of a dumpy dwarf with a big blue pitcher on his shoulder. Or you may come upon *Nemophilas* ("baby-blue-eyes") that seem to be all eyes and no baby. Strangely out of place these tender blossoms look amid their harsh surroundings of sun-scorched rock. One is almost shocked at seeing them here, and is inclined to say, "Poor little nippers—what a shame!" The poppies, on the contrary, are apt to make you laugh with their weak little rickety legs and comically tiny, scared-looking flowers—quite a contrast in behavior to the big bold fellows that stare you out of countenance everywhere else in California.

But now to come to the desert's own plants—for those I have just spoken of are but fish out of water, making the best of unnatural surroundings. The first one to catch your notice, if you lived for a spring



THE DESERT HAS EVEN A PRIMROSE

where I live, would be the incense-bush. After a winter of good rains (I mean what we call good rains on the desert, where three or four inches is the average), you would see the bare brown mountain-sides suddenly turn

golden with the blooming of countless numbers of these small sage-like shrubs, each of which sends out dozens of handsome flowers like yellow marguerites. How, among those barren rocks, life is maintained in their tough

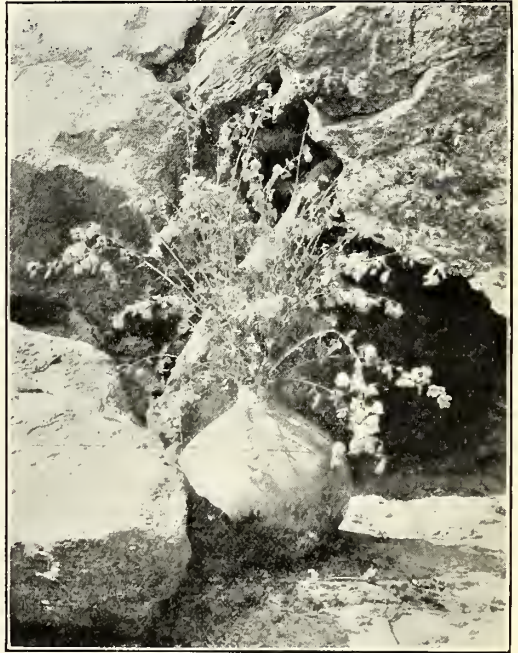

AN INDIAN WATER-JAR MAKES A GOOD VASE

little bodies through long months of rainless, blistering heat is a mystery of mysteries. The maxim of the incense-bush is, literally, *Never say die*. If there were a Victoria Cross or Congressional Medal for grit and hanging-on power in the vegetable world, this is the plant that would get my vote.

It might seem that the cacti are as much entitled to the prize for endurance as any of the desert flowers, but then, they have been specially fitted out for the life they lead, and need no praise or sympathy. Indeed, it is evident at a glance that these aggressive, self-sufficient fellows are entirely able to take care of themselves, even against the arch-enemy of vegetation, Drought. Still, it is all the more remarkable to find such fearsome objects, under the touch of spring, putting out a really glorious show of blossom. When you are watching every step for fear of being lamed any moment by the terrible cactus thorns, it is amazing to find your unlovely enemy wearing exquisite large flowers of silky rose, purple, or gold—as surprising as meeting a pirate sporting a lily in his buttonhole.





WILD CENTURY-PLANTS

There is a queer plant which, on account of its thorniness, is often wrongly taken for a kind of cactus, and which contributes one of the finest entries to the Great Spring Desert Flower Show. This is the candlewood, or ocotillo (pronounced oc-o-tee'-o), a wild-looking thing resembling a bundle of giant dead blackberry-canec. When it blooms, though, it becomes a very splendid object, each cane being feathered with small bright-green leaves and tipped with a

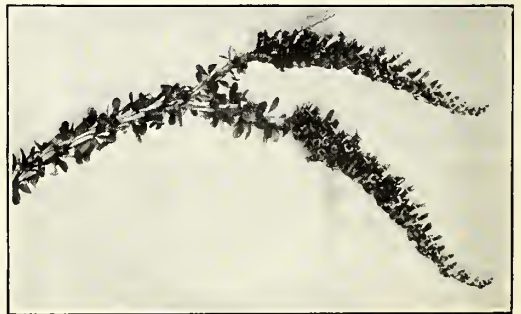

AN OCOTILLO BLOSSOM

to see and feel all the energy of those years of waiting now let loose in that thick juicy stem, rising almost while one watched, like a huge stalk of asparagus.

But I have not spoken yet of the one flower which, more than any other, astonishes and delights the springtime visitor to "the dreadful desert," namely, the abronia, or so-called sand-verbena. I hesitate to try to describe the marvelous profusion in which this lovely blossom is to be seen when the season is favorable. The picture shows a mere arm of one of the lakes of floral beauty that overflow the dull desert levels at such times. The long prostrate stems of the plants, reaching out and joining those of their neighbors, form a dense mat, in which the rosy-purple flowers quite overwhelm the green of the foliage.

Hardly less wonderful than the verbenas in quantity, though not making so vivid a display, are the masses of evening-primroses, (*Oenotheras*) which cover wide tracts with their rank grayish leaves and multitude of large, moonlike flowers. A memorable event to desert flower-lovers is the first meeting

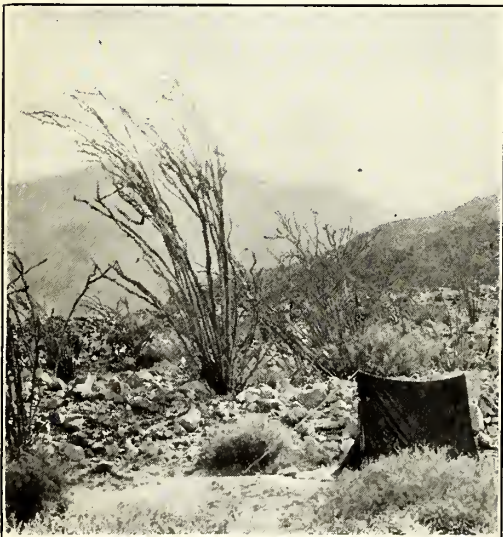

THE AUTHOR'S TENT AMONG THE OCOTILLOS



with these gentle creatures, so different in their pale fragility from anything to be expected in the wilderness. They are far too delicate to endure the midday sun, but new

other delightful plants that cheer the desert's brief spring, but I must squeeze in mention of that lowly, but enchanting, flower, the *Eremiastrum*, or desert star. It is the

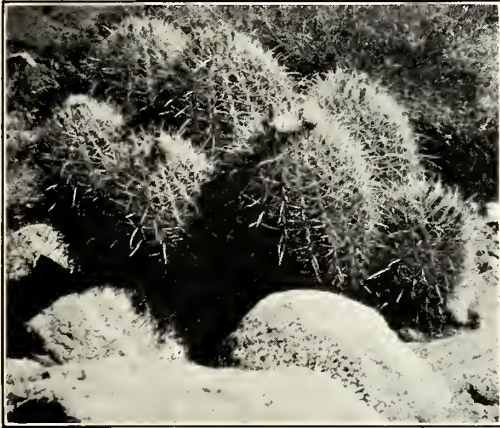

A THRIVING FAMILY OF BIZNAGAS



THE GOLDEN MARGUERITES OF THE INCENSE-BUSH

buds unfold each day as evening comes on; and nothing more restful can be imagined than, after a hard day's travel, to linger in the cooling dusk when these innocent blossoms are opening quietly by thousands and breathing out their dainty fragrance all around you, while the humming-bird moths come whirring about like little brown elves out for a bedtime frolic.

A plant that is sure to be noticed, both for its beauty of form and its unusual color, is the *Sphæralcea*, or wild hollyhock. Near the base of desert mountain-ranges one finds it, in good seasons, making superb shows of bloom, of a color which some people call brick-red, but I prefer to think of as apricot ice-cream. Exploring a cañon near one of my desert camps, I once had the good luck to come upon a large earthenware *olla*, or water-jar, that had been hidden among the rocks by Indians in some bygone time. This I sometimes use as a receptacle for wild-flowers. It seems especially suitable for these strange-hued hollyhocks, and nothing could better represent the very spirit of the desert flora.

In ST. NICHOLAS for May, 1919, I described the tall white lily that brightens these solitudes about Eastertime. With them often grows another lovely flower, the *Mentzelia*, the creamy petals of which surpass every other blossom that I know for satiny texture as well as for the marvelous delicacy of their vermilion pencils. I have not space even to name the score of

desert's own daisy, a shy little thing hardly noticeable against its background of sand, but with all the friendliness and simple charm of our old favorite of green lawns and meadows. Somehow, this insignificant, though winsome, flower gets very close to one's heart as one meets it in the lonely wastes where humanizing touches are so rare. More than any other blossom, it



"PLUCK ME AT YOUR PERIL!"

seems to tell the message of the short-lived flowers of the desert spring, the message embodied in Saint Paul's eloquent words concerning the resurrection—That which thou sowest is not quickened except it die.



# THE WINNER THAT DID NOT PLAY

By MERRITT P. ALLEN

THERE is a bronze medal offered by a certain alumnus of the Edmunds High School to the one who is most instrumental in winning the annual Edmunds-Spalding baseball game. There are other prizes which may be won for various things, but none is valued as is this one, for it always goes to a good man, and a good man, measured by the Edmunds standard, is likely to be a very good man indeed. Four of the fastest big-leaguers, to say nothing of a string of college players, have had those medals pinned to their uniforms; so, you see, it is a possible promise as well as a reward.

Like every other red-blooded Edmunds boy, Larry Mason had set his heart on that medal. As a freshman, he had been a second-string pitcher; the next year he had substituted on the first team, playing in the less important games; as a junior, he had been old Dix's alternate; and finally, in his senior year, he was the mainstay of the team, Dix being gone.

Larry was a good pitcher, steady as a clock, with control almost mechanical in precision and any number of curves; but by the time the season was a month old, his one weakness, that had always been with him, began to show up again—he lacked speed. No matter how hard he tried, he could put the ball over only about so fast. In former years, when old Dix was there to infuse "wallop" if a crisis demanded, things went well. Now it was different. Among the other high schools it became noised about, as such things will, that Mason's pace was always the same. He might vary his ins and outs, his drops and his jumps, but there were none of those lightning deliveries so disconcerting to batsmen. His opponents learned to swing slowly at everything, and consequently they connected more and more frequently with the ball. He worked magnificently, but he knew that, without the superb backing of his team-mates, Edmunds would have gone down far oftener than she did.

This worried Larry, more on the team's account than on his own. He felt it in his bones that, unless something was done, the school, because of his inefficiency, would bow to Spalding. In spite of his faults, he was the best pitcher on the squad—a fact

that he treasured in his heart, though he would not admit it. There were plenty of out-fielders and in-fielders and catchers, but he was the only pitcher who could stand up in a big game. Therefore it was up to him to save the day. He knew it, and he began to work as he had never worked before.

He practised every afternoon on the field under the coach's special supervision, and all spare moments at home by himself. Collecting half a dozen old baseballs, he would go out in the back yard, and there he would hurl them at the barn, then hurl them back at the woodshed, trying patiently to discover some new swing or body motion that would increase his speed.

"That makes you a lot of travel," a voice said over the back fence one morning. "I'll return them."

Larry looked up to see Ralph Howard vaulting the fence. Ralph had been in high school for two years, but few of the boys knew much about him except that he lived out of town somewhere and was so busy working his way through school that he had no time for other activities.

"Get a mitt and I'll catch you for a few minutes," he offered, picking up a ball.

Larry, glad of the chance, though wondering what this fellow knew about ball-playing, brought out a mitt. It was soon evident that Ralph had seen a ball before, for he caught very well; in fact, he gathered in Larry's sharpest curves almost casually.

"That drop broke a little too slowly," he remarked after a time. "Bring your arm down quicker from the shoulder."

"Where did you learn to play ball?" Larry asked in honest surprise.

"I have worked for two summers in a hotel where I played on an amateur team."

"What did you play?"

"Oh, I pitched some."

Larry eyed the other, who was almost a stranger for all that he had been in school for two years, with added interest.

"Give me that mitt," he said impulsively, "and throw me a few."

"I am out of practice," Ralph protested, as he handed over the mitt and slipped on the glove.

Larry had caught old Dix for practice, but this Howard had something to show him. His

control was erratic; but after he warmed up, the balls came across like bullets. Speed? There seemed to be no end to the fellow's speed. If he ever learned control, he would be a wonder.

"Look here," Larry asked, at the end of ten minutes, "why have n't you tried for the team?"

"I am working my way through," Ralph answered, rather wistfully, "and I have n't the time."

"But there is stuff in you," persisted Larry, to whom baseball was everything.

"Perhaps. But I can earn a dollar mowing lawns every afternoon while you are practising, and I need the dollars."

The next Saturday, Edmunds went up against Rutland and was defeated. The papers said that Larry pitched a good game, which was true; but he knew, as many others did, that his inability to alter the pace of his delivery was responsible for dropping the game. Wendell, the Spalding coach, was present and smiled knowingly. It was plain as day that he had sized up things and when the big game came off five weeks hence his team would be prepared for Larry as never before.

Larry said little, but for days he was different. He kept alone, and there were times when he looked as people are said to look who are fighting themselves. Then suddenly he was himself again; and that afternoon he sought out Ralph Howard, who was mowing a lawn uptown.

"Look here," he began abruptly, "did you ever hear of duty?"

Ralph leaned on the mower handle and confessed that he had.

"Well, your duty is to the school, the same as any one's who goes there."

"What are you driving at?"

"I mean it is your duty to get in shape to

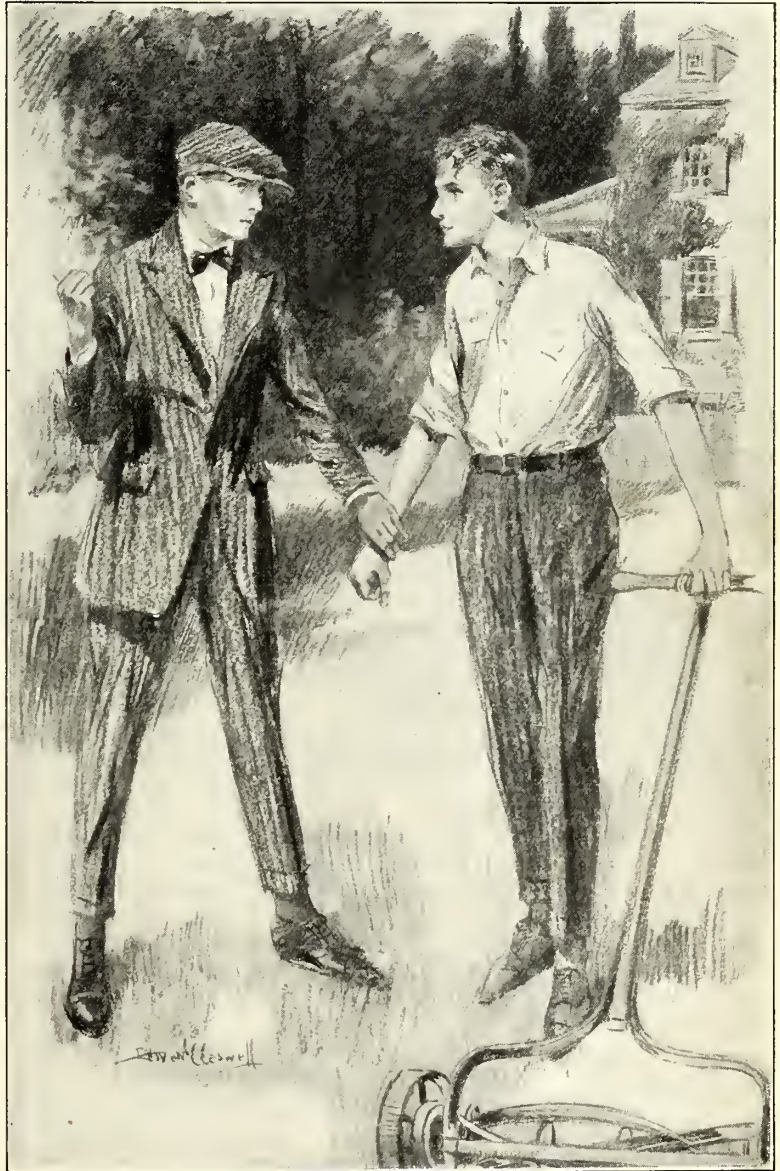

"'I 'LL DO YOUR WORK,' LARRY TOLD HIM"

pitch the Spalding game. We can't afford to lose that one."

Ralph was the most surprised boy in seven counties, but all he said was, "I have to work."

"I'll do your work," Larry told him.

"You? You are the pitcher. You must practise."



"I'll give it up—part of it, anyway."

Ralph was beginning to doubt his ears. "The coach would n't allow it," he said.

"I've seen him about it. He wants you on the diamond in half an hour."

"This lawn—"

"I'll tend to this lawn."

"I—I have n't any togs."

"Mine are in locker 7."

"Hold on—"

"Don't you suppose I can mow a lawn?"

And as Ralph stood in a daze the mower started off at a sharp clip.

That evening Ralph went around to the Mason house.

"Well," Larry asked, meeting him on the porch, "what did the coach say?"

Ralph hesitated. "He said he wanted me to come out every day."

"I knew it. You told him you would?"

"No. How can I?"

Larry made an impatient gesture. "How many hours do you work outside of school each day?" he asked sharply.

"About three."

"Then you and I can do it in an hour and a half—that gives us an hour and a half for baseball practice. I can keep in trim and you can brush up in that length of time, if we work hard. Of course, you get pay for the full three hours just the same."

"What do you get?"

"If we lick Spalding, that is enough for me."

Ralph shook his head.

"But you must do it!" Larry cried.

"You are the better pitcher and the game depends on you. Have n't you any school spirit?"

"Speaking of school spirit," Ralph said slowly, "it seems to me that you have enough of that for the whole team."

"Shucks!"

"You are deliberately trying to get me in shape to crowd you out, to pitch the game, the big game that you have been dreaming of for four years."

Larry did not tell him of the bitter fight he had been through before he decided to do that very thing.

"What kind of a sneak would I be if I sacrificed the game for the sake of playing in it myself?" he asked. "I hope you don't think I am that kind. Any of the fellows would do just as I am doing."

But Larry knew that there was not one in a hundred who would do it, and his admiration for Larry Mason was great.

"I'll do the best I can," he promised simply. "You have shown me the way."

The next day, several persons were surprised. First, it was the baseball squad, when Ralph turned out for practice; and later, many others looked twice and again at the sight of Lawrence Mason, pet son of one of the first families, pushing a mower up and down Dr. Martin's lawn. The same thing happened day after day, and though neither of the boys most concerned offered an explanation, their actions soon displayed the truth.

Joe Powell, the Edmunds second-baseman and captain, became alarmed least Larry would cut too much practice, and went to the coach about it. After a short conversation, they went up to the office of Mr. Adams, the principal, where the three had a long and apparently satisfactory talk. After that, Ralph received the special attention of both captain and coach during practice, often to the neglect of Larry, who did not seem to care, no matter how he felt.

The coach still thinks that he made a finished pitcher out of Howard, but, he did not do it all. In spare moments, when their work was done, Ralph and Larry would get out behind the Mason barn and labor hard. Ralph's speed and curves were excellent, but his control was uncertain, and it was on the correction of this that they put most of their time. Patiently, hour after hour, he strove to shoot them over the white board cut to the exact size of a home plate; and Larry, past-master of control, worked just as hard coaching him, and pushed the mower faster that he might have more time to coach.

Such work was bound to show results, and as each week brought greater improvements in the new pitcher, the coach evolved a daring plan. He would keep Howard for a "dark horse." Not a single game should he pitch until the Edmunds-Spalding battle, when he would be sprung as a surprise on the visitors. It would be risky, this putting a new and untried man into the big game, but the Spalding boys were coming prepared for Mason's peculiar delivery, so the speedy Howard might fatally upset them. It was worth trying, anyhow.

The day came, and no one except the coach, the captain, and the two pitchers knew that Howard would be on the mound, until he began warming up. People started asking questions. Who was this fellow? What was the trouble with Mason? The Spalding coach sought out Mr. Adams and

learned that Ralph had been an Edmunds student for two years past. Why had he not played before? Mr. Adams believed he had been too busy working his way through school. The coach went back to his side of the field, feeling uneasy.

Every one who saw that game, and the crowd was a record-breaker, will talk of it for years to come. It was a classic in high-school baseball. Before three innings had been played, it was evident that the teams were so evenly balanced that it would be a pitchers' battle to the finish and that, barring a fluke, Harlan of Spalding or Howard of Edmunds would tip the scales of victory. And those two boys were little short of marvelous. Harlan was a tower of strength, smiling, alert, never flustered, always with more brain and brawn than each crisis demanded. On the other side was Howard, "the dark horse," for the first time in an Edmunds uniform, working like a machine, a wonderfully intelligent machine, taking the game seriously and silently and piling up a glorious record for himself. The Spalding team was full of fight and resourceful, but his variety of curves, his bursts of astounding speed, all dominated by the control Larry had taught him, kept them down. Crouched on the bench, Larry Mason, who for love of the school had given up pitching this greatest of all games, had the consolation of knowing that he had not acted in vain—Ralph was playing a better game than he could.

By so clever a combination of head and stick work that even the Edmunds crowd burst into cheers, Spalding got a man around the bases in the fifth inning. Three innings later, Edmunds evened it up; and thus tied 1 to 1, they entered the ninth at white heat.

Big Pell, Edmunds catcher, opened up with a cracking hit. There was the drum of scurrying feet, and a white line rose higher and higher over right-field. Across the distant grass, two forms came suddenly to life and raced toward each other—Mack and Bacon, the Spalding center- and right-fielders. From the stands, the crowd, now on its feet, watched breathlessly. Along the rim of the diamond, Pell's spikes were tearing up the dirt; a haze of yellow dust hung trembling behind him. The distance between the two fielders was shortening.

"Mine!" shouted Mack, and settled to receive it. But it was not his. At the last instant, a puff of wind caught it, veered it, and it fell to the ground.

"Hold it!" bellowed the Edmunds coach as Pell rounded second. The big fellow dug in his spikes, bent double by his suddenly resisted momentum, wheeled, and slid back to the base an inch ahead of the ball.

Orton was next up and went out on a grounder to first; the baseman was too slow, however, to double Pell at third. Elderkin followed, and died miserably on a foul to the catcher. Then came Powell, the captain, bristling with fight, as usual. He gripped his bat close to the end, swung mightily, and drove a scorcher between first and second. Bacon scooped it up on the first bound and made a perfect throw to the plate, but Pell, who had started with his chief's swing, had his luck with him and slid safely home amid dust and glory.

Edmunds was leading 2 and 1, a small margin and all they were destined to have, for the next man fanned.

But Spalding was not defeated yet. There was not a quitter on the team, and they went into the first half of the ninth like tigers. To Howard, as he faced them, they seemed to be as fresh and much more formidable than in the beginning. He was tired. The terrific pace set by his opponent, the older and more experienced Harlan, had told cruelly on the young pitcher. His brain was not so clear nor his body so steady as it had been. To his dismay, he passed the first man up. Spalding went wild and the din became deafening, a great whirling ball of sound. On the Edmunds bench something was white. It was Larry's face, strained and tense. To him, who had made the greatest sacrifice, the game meant more than to any one else. Ralph knew this, and the sight of that face seemed to give him new power, as the flag invigorates a soldier. He called up all his reserves and struck out the next man.

Now Mack, who had the reputation of being the brainiest batsman on his team, was facing him. Three times that day he had missed fast out-curves, which was the reason that Pell called for another then. But Mack outguessed him, and, as the ball shot toward him, he jerked his bat behind him and, stepping forward, crashed it against the leather before the deceptive twist could begin. When the ball was again in Howard's hands, there were men on second and third.

Bacon was pawing the ground at the plate, and as the tired pitcher watched him he knew that the crisis was at hand. Bacon was famed as a bunter, therefore he was sure



to bunt, for the effect that three men on bases would have on Howard. He would be followed by the heaviest hitters on his team, and Howard felt, as Spalding guessed, that

was afraid. He saw Larry's face again, whiter than before, and a blush of shame crept into his own face—shame at the thought that he dared consider losing Larry's

game. For it was Larry's game more than any one else's. He had sacrificed his own ambition that it might be won; now if it was lost— As Ralph stood there slowly fingering the ball he declared that it must not be lost. He on whom Larry had pinned his faith must justify that faith. He must hold together. He must outwit the batsman as Larry himself would do. But what would Larry do? Ralph thought rapidly, going over the advice Larry had given him, until the umpire motioned impatiently for him to resume play.

Then it all happened very quickly. Howard's arm went up and out and a slow straight one sailed over the plate. As it left his hand, though, he dashed from the box to the third-base foul-line, the place where Bacon always sent his bunts. Bacon fell into the trap and bunted. Howard snatched up the ball and threw it to third, forcing the runner there, and the next instant it was snapped to second, where Mack was caught off bad. Three out!

The pitcher had won the game; but so differently from what the crowd expected, that it was several seconds before they realized it. Then they broke loose.

That night there was a banquet for the winners and the certain alumnus was there to present his medal in person.

"I believe," he said, after a few preliminaries, "that you will all second my choice when I name Ralph Howard as the one who was

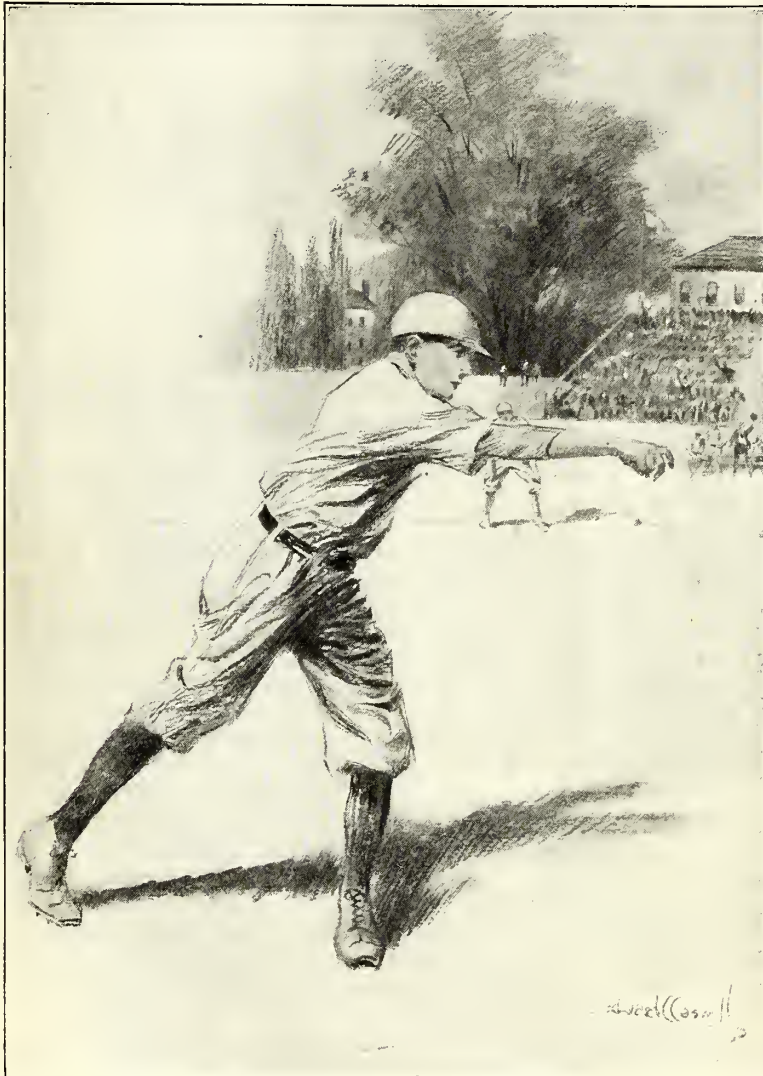

"HOWARD'S ARM WENT UP AND OUT AND A SLOW STRAIGHT ONE SAILED OVER THE PLATE"

he would not be able to strike out two. The chances were that almost any kind of a hit would tie the score or win outright. His arm was desperately tired, his nerves jumping. For a sickening moment, he believed that he was going to pieces.

But he must go on until he broke—it was a law of the game. He felt that the next ball he pitched would win or lose all. He was afraid; but he could not stop because he

most instrumental in winning the greatest of all Spalding games."

A cheer started, and stopped as Ralph jumped to his feet and motioned for silence. "Pardon me," he said, "but I can not allow such a thing to happen. Let me explain why." And in short, straightforward sentences he proceeded.

"I never would have played at all, you see," he eventually summed up, "if it had not been for Larry. He thought more of the school than of himself. He was willing to give up the thing he most wanted to do that Edmunds might win. It took more than ordinary grit to sit on the bench that way when he might have been in the big game.

"But he won the game after all. I want to tell you about it. When I faced the last man, I was all in. I was in a hole and could not get out. I was beaten. I did n't know what to do; and if I had thrown one more ball in that condition, we would have lost the game. And we *would* have lost it but for Larry. When I thought what it

would mean to him, thought of all he had done and given up, how he had mowed my lawns and coached me into shape—when I thought of all that, well, it just seemed that we *could n't* lose with such a fellow as he is on our side. That gave me confidence. I got steady again. And then a scheme he had told me of popped into my head. He told me how to work it one afternoon when we were mowing lawns together. The idea was to throw one that the man, Bacon in this case, could bunt, then run over toward third and force the man there; after which, there would be time to get the other at second. I did it, as he had told me how, and it worked. First, by his sacrifice he made it possible for me to play. Second, by his coaching he made it possible for me to win. Gentlemen, that medal belongs here." And he laid his hand on Larry's chest.

The alumnus, the coach, and the principal exchanged glances.

"We entirely agree with you," said the alumnus, as he proceeded to pin the medal where it belonged.



WHAT THE LITTLE BIRD SAID: "EARLY CHERRIES, AS I LIVE!"



# THE HILL OF ADVENTURE

By ADAIR ALDON

## SYNOPSIS OF PREVIOUS INSTALMENTS

IN the small town of Ely, in the Rocky Mountains, Beatrice Deems, her sister Nancy, and her Aunt Anna settle down for the summer. The town is full of foreign laborers who, led by a Finnish-Russian agitator, Thorvik, begin rioting when the irrigation company that employed them ceases work on account of lack of funds. Finding Ely untenable, the household moves to a cabin on the mountain-side. They are helped by Christina Jensen, a Finnish woman, whose son Olaf is a sailor, at home on leave; but he dare not go near the village on account of a mischievous prank he played before he went to sea.

The cabin's nearest neighbors are John Herrick, the head of the irrigation company, and his adopted daughter Hester. A would-be reporter and amateur detective, Dabney Mills, is seeking to solve the mystery of why the company is without funds when it had seemed so prosperous. Dr. Minturn is another friend who lives on the other side of the mountain.

The girls' invalid aunt finally breaks her long reticence and tells them the reason of her coming to Ely, the hope that she may find trace of her brother Jack, who, thinking that his family suspected him of dishonesty, broke with them and disappeared ten years before. The girls believe that John Herrick is this brother, but do not tell their aunt, fearing to raise false hopes. To Beatrice's consternation, Dabney Mills confides to her that he thinks he has solved the mystery of the irrigation company's funds, that he believes a sum of money has been made away with, and that he suspects—John Herrick.

## CHAPTER XIII

### OVER THE PASS

THROUGH all the night that followed Dabney Mills's veiled accusation of John Herrick, Beatrice slept very little. A tireless procession of thoughts went trooping through her weary mind: Aunt Anna's story of her brother, that strange vision of John Herrick walking back and forth in the moonlight, the sight of his departure. What did all these things mean in the end? Perhaps John Herrick had gone away forever; perhaps Dabney Mills had real proofs of—no, no, that could not be! Come what might, she would never believe anything against John Herrick. It was a help, at least, to think that next day she was to go over the pass to bring Nancy back, and that she could ask the advice of Dr. Minturn. He alone could be trusted with knowledge of both sides of the affair; he would give her counsel from a wise and friendly heart. The comfort of this thought brought her sleep at last.

As early as she could make ready, she set off next morning. She stopped for a minute at the door of the Herricks' house, hoping to hear that she had been mistaken in her understanding of what she had seen. But no, Hester met her at the door with heavy eyes and told her that John Herrick had gone away very suddenly, "soon after that horrid boy, Dabney Mills, had been here. He took his tent and quite a supply of food. He may have been planning to camp several days, but he did n't tell me where or why.

He just said, 'So long, Hester; better luck by and by,' and galloped away."

Much disheartened, Beatrice turned her horse's head to the trail and began to mount steadily the zigzag path that led to Gray Cloud Pass.

It was not so clear a day as yesterday had been. The sun shone with less warmth, even as noon approached; the hills were dun-color and the far mountains purple instead of blue. Beatrice was not weather-wise enough to know what such signs meant, nor could she have hurried forward more impatiently if she had. Even the willing Buck finally protested against the haste that she demanded of him and refused to increase his speed even when she touched him with the whip. There was a certain stretch of level ground that she remembered, a nook between two rocks, with the stream splashing below, that she was determined to reach before she stopped to eat her lunch. She came up the last rise of the steep path, in her haste too unobservant to notice the thin curl of blue smoke that was going up from behind the rocks. Having slipped from the saddle, and with Buck's bridle over her arm, she turned the corner of the wall of rock to find her picnic ground occupied. A little fire was burning between two stones, a string of trout hung before it, and a slim black mare grazed lazily beside the mountain wall. The man who turned to greet her was John Herrick!

Her mind had been so full of thoughts of him that, for the moment, it seemed impossible to speak naturally. He, also, for a

full minute, stood surprised and apparently unable to utter a word. He took Buck's bridle from her at last and, still in silence, loosened the girths, lifted off the saddle, and let the pony roll luxuriously on the grass.

"You have ridden him too hard," he said at length, looking at the horse's wet sides and wide nostrils. "Not even a mountain-bred pony can stand such a pace. Why did you hurry so? Was there anything the matter?"

"N-no," replied Beatrice, doubtfully. She could not have told him why she had been in such impatient haste; perhaps she could not even explain it to herself. Certainly she was in no hurry to go forward now, but knelt down by the fire and fell to turning the trout while he picketed her horse and spread a blanket for her to sit on. As she looked up to thank him she saw that the heavy cloud that had been visible on his face when she first saw him was lifted now, making him his smiling, cheerful self again—as though her chance coming had done him good.

Their picnic became a very merry one. They joked and laughed as they shared in the preparations; he tried to teach her how to make flapjacks and laughed at her awkwardness when he attempted to toss them; she criticised his method of boiling coffee and made him admit that hers was better. As they sat eating he told her tales of past camping adventures: how he had once crawled into a cavern under a cliff to take shelter from the rain and discovered that it was the home of a most unamiable mountain-lion; how, in his tent far up on Gray Cloud Mountain, a grizzly-bear cub had slipped under the canvas and invited itself to share his bed.

"And I had to be polite to the pushing, grunting little beast," he said, "for its mother and my rifle were both outside."

After they had finished their lunch, they still sat lazily by the fire, watching the thin smoke drift afar across the depths below them until it lost itself in the distant blue haze. Beatrice was leaning against the warm rock, while her companion sat upright, his clear-cut profile showing against the vast blue sky.

"He seems hardly more than just grown up, when he talks and laughs like that," was her inward reflection. It seemed as though he had dropped the burden that had been so heavy for all these years and, in this hour of friendliness, had gone back to the boyhood he had cast from him.

He was pointing out to her the wide, dry lands of Broken Bow Valley which, with irrigation, were some day to be orchards and meadows and rich farming country, instead of a broad waste, polka-dotted with sage-brush. At some length, he told of the difficulty in getting the irrigation project started—of how long it had taken to form a company and to get construction under way. But of the later developments he did not speak—of the interruption in the work, of the threatened strike, and the disappearance of the company's funds. Beatrice waited, hoping that he would let fall some explanation, throw some light on that mystery, and refute the dismaying suspicions of Dabney Mills. Of that phase of the matter, however, he said no single word.

"When it is all finished and the valley is prosperous," he said, "you must be careful when sharp traders try to buy your cabin from you, or make bids for your big pines. You must not part with them at once."

"I think I could never part with them," she assured him; "I did not know how much I could learn to love the woods and the cabin and the mountains."

He sat for a little while, looking across to where the shadows of clouds moved, one by one, across the dark slopes of the range opposite.

"They are friendly things, these mountains," he observed. "They stand by you when you are in trouble, somehow—they are so big and calm and untroubled themselves."

Their friendship and confidence had brought them so close together that Beatrice felt suddenly the thrill of a bold impulse. She cast aside Dr. Minturn's advice to let John Herrick make the first move toward reconciliation; it did not occur to her that the man beside her might be talking so freely only because he meant so soon to close his friendship to her forever. She reflected only on how triumphant she would be when her management had brought the whole misunderstanding to a happy end. Yet she did not dare speak out at once.

"Only think," she began suddenly, "that you and I might be lunching at—at the Biltmore together if things had been a little different."

"Yes." She was greatly encouraged by his immediate assent. He looked at his gray flannel shirt and at her patched riding-skirt and went on. "We should n't be dressed just as we are now, should we?"



And there would be music, instead of the sound of the stream, and a hundred voices talking all at once, instead of those two magpies chattering in the thicket. The fat lady at the next table—there always is one—might be wearing a beaver scarf made from the jacket of some furry little fellow that swam in that very pool below us, and the waiter might tell us that there was an unusual delicacy to-day, rainbow-trout."

She leaned forward, feeling bolder still. "You have n't forgotten," she said, "and you will be coming back to it all some day. We know who you are. We want so much to have you belong to us again. Are n't you coming back?"

"You know?"

He stood up suddenly and faced her. In that instant she knew that she had done wrong. The shadow of unforgettable pain swept over his face and the laughter died in his eyes.

"You know?" he repeated.

She did not trust herself to speak or even to look at him. Mutely she nodded, keeping her wide, unseeing eyes on the fire, clenching her hands, holding her breath, and waiting. There was a long, long pause.

He moved at last, strode to the fire and trod out the flames and the smoldering coals with his big boots.

"It is time we were going on," he said. "You must reach Dr. Minturn's before dark, and I have none too much daylight left to climb my own trail."

Helplessly, she stood watching while he caught the horses and saddled them. The black one yielded quietly enough, but Buck, according to his usual habit, filled the whole rock-walled space with his plunging and rearing, a small, but spirited, sample of Wild West Show. He had to yield at last, however, and was led to where his mistress was waiting. John Herrick's hat was off and his fair hair was ruffled both by the wind and by his struggles with the reluctant pony. Beatrice noticed as never before how like he was to Aunt Anna. Since she had done so much harm already, she felt she might make one more effort.

"Are n't you coming back?" she questioned desperately.

"No," he answered, "I am never coming back."

He swung into the saddle and, with a great rattling of stones dislodged by the pony's hoofs, he was off up the steep trail. It might have been that he looked back,

once, to see a bright-haired girl hide her face in her arm and bow her head against the rock, while a white-nosed pony nuzzled her shoulder in a vain effort to offer comfort. But if John Herrick looked back, he paid no heed.

## CHAPTER XIV

### DEAD MAN'S MILE

It was comfort, rather than advice, that a very weary and dispirited Beatrice needed when at last she arrived at Dr. Minturn's house. She greeted the rosy, laughing Nancy with much enthusiasm, for the sisters had missed each other sorely, but she was impatient for a moment when she could talk over the whole affair with the kindly old doctor. He was the sort of person to whom one could tell anything, so that there had never been any question in her mind as to the advisability of taking him completely into their confidence.

After supper he sat on the grassy bank in the moonlight with a girl on each side of him and listened gravely to all that Beatrice had to say. It was not easy for her to confess what harm she had done by her impulsive and over-confident words, but she told her story bravely to the end.

"There is no use in the world," the doctor commented cheerfully, "in spending time in vain regret. We must decide what is to be done now. It may be, the only thing is to wait. That seems hard, for to be eager and ardent is part of being young; but to learn that eagerness does not bring all things is a truth that the years teach us."

He made a gesture toward Gray Cloud Mountain, a towering black bulk against the twinkling stars.

"He is learning his lesson too, that boy up there, camping in the dark and the silence, thinking and thinking all alone, coming nearer and nearer to the truth of things at last."

"Do you—oh, do you think that he might change and come back to us?" cried Beatrice, in eager hope.

"I have no doubt of it; and when the time comes for you to act further, you will know what to do."

A very sleepy and comforted girl was tucked into bed by the doctor's wife—a young person who thought she could not sleep on account of her many anxieties, but who was lost in slumber almost before the door closed. She did not even hear the storm

of wind and rain that swept over the cottage in the night, but awoke in the morning to see the sun shining and to hear a camp-robbler jay calling so loudly from the nearest tree that she could sleep no longer.

"Your horse is not fit to go back for a day or two," Dr. Minturn said at breakfast. "You pushed him too hard when you climbed the pass, and you should leave him here to rest. I will lend you my brown Presto. He is not such a pony as Buck, I admit, but he will carry you safely enough. You can come back for your horse later, or I will send him over to you when some one passes."

The sun was high when she and Nancy set out together, shining above the pass as they mounted upward.

"But there is something the matter with it," Beatrice declared to her sister; "there does n't seem to be any warmth in it, somehow." And she shivered a little.

An unusual haze seemed to hang like a blanket between them and the sun, and the air held a strange chill. Even when wrapped in their warm coats, the two girls felt cold as they climbed to the summit of the pass and began the descent on the other side. Beatrice said very little, so busy was her mind with many difficult problems. Must she tell Aunt Anna what had happened, and let her know that all hopes of meeting her brother were at an end? Would John Herrick's house soon be closed and would Hester have to leave them too? Would it be of any use—

But look! what was that lying beside the trail? Something huge, dark, and unwieldy was stretched out among the bushes! It was a black horse, apparently dead. They both knew those white feet and the brand on the flank—it was John Herrick's black mare Dolly!

They dismounted, while the poor creature opened its eyes and managed to raise its head. A horse that is so injured that it can not get up when a person comes near is sorely hurt indeed. That much Beatrice knew, yet was powerless to discover what was the matter. By some intuition, Nancy guessed one thing, at least, that was needed, for she ran to the stream, filled her felt hat with water and brought it back, spilling and dripping, but with enough left for the poor animal to drink gratefully.

"I wish you could speak," Beatrice said helplessly, as the mare laid her head down again. Presto nudged her inquiringly with his nose, but she did not move.

They noticed, as they stood looking at her, that the bridle was half torn off, that the big saddle, with broken cantle, was twisted to one side by the pony's fall. On the face of the mountain wall above them they could trace Dolly's disastrous course in trampled bushes, weeds torn up by the roots, gouges in the rocky soil where she had slid and rolled and struggled to regain her footing. But look where they might, they could see no sign of John Herrick.

"When the time comes to act, you will know what to do."

So Dr. Minturn had said, and he had been right. Beatrice knew well that now was the moment for action, not waiting, and she felt her mind surprisingly calm and cool. They must follow the spidery line of trail that zigzagged back and forth over the precipitous mountain-side, and find the spot, high above, from which the black mare had fallen.

"You wait here, Nancy," she ordered; but she heard the other horse's hoofs pattering behind her even as she turned and realized it was useless to try to make Nancy stay behind. What was it Hester had said that way was called, that tiny path that crawled out upon the smooth face of the rock wall? It was Dead Man's Mile.

There were moments when the brown pony slipped, moments when the vast depths below made Beatrice so giddy that she was forced to shut her eyes. A big stone rolled from under Presto's foot, and he drew back only just in time to keep from plunging over. Beatrice tried not to watch it, but she could not keep her eyes away as the stone slid and bounded in longer and longer leaps until it finally disappeared into the woods below.

"Are you safe, Nancy?" she called. She did not dare look back.

"Yes," came the reply, rather unsteadily, from Nancy close behind.

Up and up they went. It seemed as though they would remember for all their lives every treacherous inch of that trail, along which they crawled as a fly crawls crookedly up a window-pane, and yet that they would never be able to find the way down again. Up and up—and there, suddenly, was John Herrick, lying on a narrow shelf of rock just beyond them, his white face turned upward, and the stones and tufts of grass all about him stained with blood. Just ahead, at the turn of the trail, she could see his little tent, his various belongings heaped together, and the drifting,



aimless smoke of his still-smoldering campfire.

Before Nancy could even cry out, Beatrice was down from her horse, and was kneeling beside him. A gash across his forehead was

Beatrice knew, at least approximately, what to do. But could she be quick enough? Might she not already be too late? Could any one lose such a quantity of blood and still have a chance for recovery? As she twisted her handkerchief she tried frantically to recall just what she had been told, how to tighten the knot, exactly which spot was the proper one for pressure. But how desperately hard it was to remember!

Those first-aid lectures,—it was only because every one else was going to them that she had attended at all. And she was rather bored by the time she had reached the third one, and prone to let her mind wander. With maddening clearness, she could recollect how she had looked out of the window, glanced at one girl's hair-ribbon, decided she would have a dress like the one in front of her, and, with only half her mind, had listened to what the lecturer was saying. And now John Herrick's chance of life was hanging on her memory. Nancy was standing beside her, helpless, horrified, unable to be of use until Beatrice should tell her how.

Beatrice remembered now; she had found where the pulse still beat feebly; she had arranged the pad

to press against the bone; she was telling Nancy how to help her twist the bandage tight.

Slowly the trickle of blood lessened, came forth, at last, one drop at a time, and finally ceased altogether. It seemed a long, long wait before John Herrick opened his eyes.

"Was Dolly killed?" he asked first. Then,

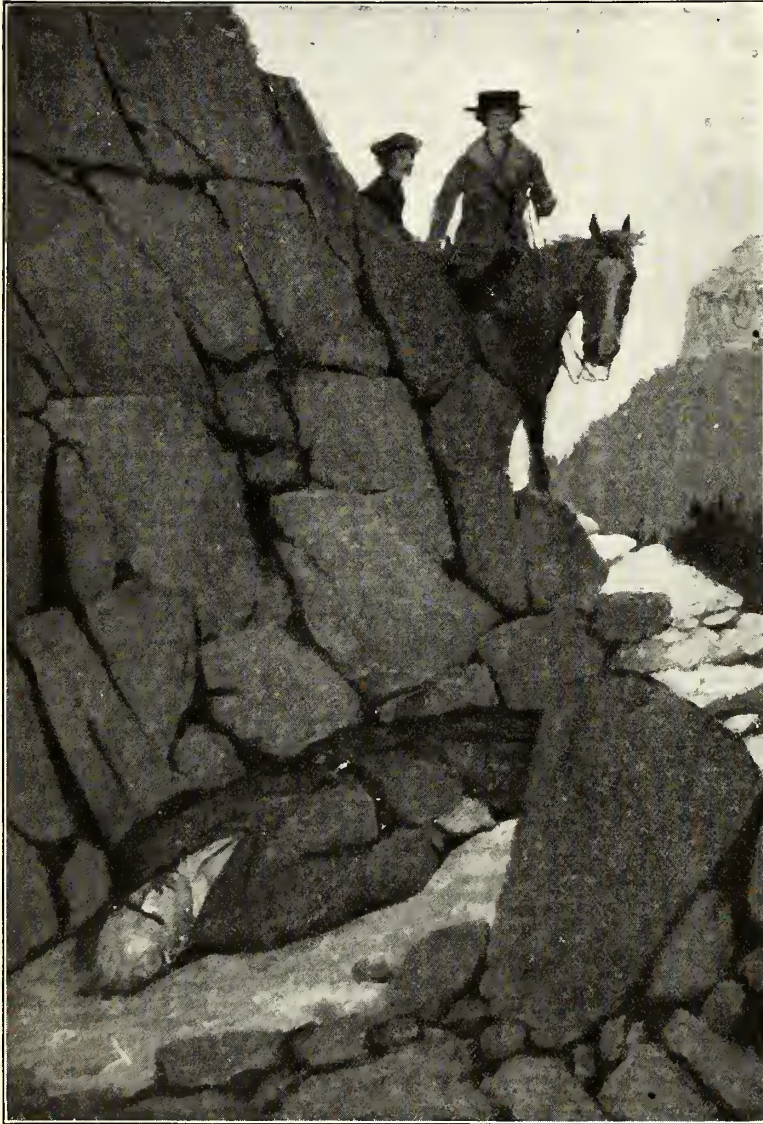

"THERE WAS JOHN HERRICK LYING ON A NARROW SHELF OF ROCK"

his most evident injury, but that could not account for all this blood. No, here on the under side of his arm, where the sleeve of his coat was torn away, this was the deeper wound from which had poured forth that crimson deluge that had soaked his clothes and stained the ground under him. Thanks to instructions she had received long ago,

after a little: "How do you come to be here? Surely you never climbed that trail alone?"

It was a grisly nightmare, their attempt to get him up to the level bench of ground where he had pitched his camp, but they managed it at last. One effort they made to lift him into Presto's saddle, but it was attended with so little success and such evident agony that they gave it up.

"There 's something broken—besides the cuts in my arm," John Herrick muttered, and lapsed into unconsciousness as they managed to drag him under the shelter of his tent. They propped up his injured arm on a roll of blankets, replenished the fire, and sat down on either side of him to wait until he should rouse himself again.

Although it was high noon, the sky was strangely dark; and even under the sheltering wall of the tent the air was growing very cold. Heavy masses of cloud were sailing across the overcast sky, and the mountains were taking on a strange, somber color that was so unfamiliar as to be terrifying. On looking down, they saw that John Herrick had opened his eyes again and was staring up at them without moving. In answer to the unspoken question in Beatrice's eyes, he began to explain very slowly, with long pauses for rest.

"I fell very early in the morning, before dawn, just as the thunder-storm was going by. I could not sleep and from pure restlessness had been across the mountain slope. I was riding recklessly in the dark. Poor Dolly knew we were in danger and hung back, but I kept urging her on. She missed her footing, and I was flung clear, but I could not move. I could hear her scrambling and rolling and falling farther and farther below me, but I could not even turn my head. You say she was really still alive?"

He was quiet for a long time after this effort, but at last spoke again.

"You have made me very comfortable," he said. "You have done everything possible. Now it is time for you to go."

"Go?" echoed Nancy; "why should we go?"

His eyes were looking beyond her at the threatening sky, and that ominous, deep-

ing color of the range opposite. Only one peak, the highest, stood shining above the others, still bathed in fitful sunshine; but in a moment the enveloping shadow had crawled up the slope and quenched its solitary brilliance.

John Herrick spoke again, more insistently. "At the very best, it makes me shudder to have you two go down that trail alone, and you must do it while the light is good and there is nothing to hurry you." He struggled to raise himself upon his uninjured arm, and added sharply, "You are not to delay. You can send some one back to find me."

Nancy got up obediently and went outside the tent. The two horses were standing beside the fire; she took their bridles and waited. It was her elder sister who must decide what they were to do.

A bank of cloud, seething, boiling, dark below, but white at its upper edge, like surf breaking on a reef, was rolling over the summit of the rugged height opposite. The slow roar of the rising wind could be heard stirring the tree-tops in the forest below.

Seeing Beatrice hesitate at the door of the tent, John Herrick broke forth with the desperate truth: "There is snow coming. An hour of it will make the trail impassable for you. It will be cold as midwinter before night, and dark long before then. There is not a minute for you to lose. Beatrice, my dear, my dear, what does anything matter if harm comes to you and your sister? Go—go!"

A breath of wind touched Beatrice for a second and was gone; yet its icy chill cut her to the very bone. Through the comparative warmth of the air about them, it had appeared and vanished like the dread ghost of that bitter cold reigning up yonder where the snows never melted and the ice-fields clung to the mountain-side the whole year through. Nancy shivered, and the brown pony, trembling too, shouldered close to her. But Beatrice, in the door of the tent, turned suddenly to regard John Herrick with steady eyes, with a look as fixed and determined as his own.

"We are not going to leave you," she said.

(To be continued)



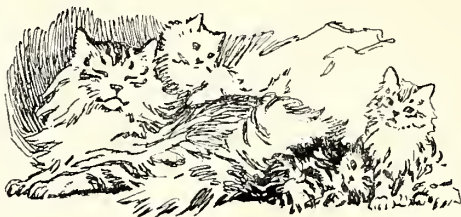

# The Pet Shop

By Clara Ewing Espey

THE pet shop with its treasures  
 Lures the hurried passers-by,  
 Who are tempted by its pleasures,  
 Scanning them with eager eye.  
 For they find a fascination  
 In its varying display,  
 And a moment's recreation  
 As they pass it every day.  
 There are chickens,—oh, so cunning!—  
 Guinea-pigs so sleek and fat,  
 Kittens in a corner sunning,  
 And a big Angora cat;  
 Pigeons, with their iris marking,  
 And some goldfish in a bowl;  
 Lonesome puppies feebly barking,  
 Tawny, white, or black as coal;  
 Some canaries, green and yellow,  
 And a cage of little doves;  
 Rabbits that each little fellow  
 In the city dearly loves;  
 For each one who daily lingers  
 To enjoy them and their charms  
 Longs to feed them from his fingers  
 And to take them in his arms.

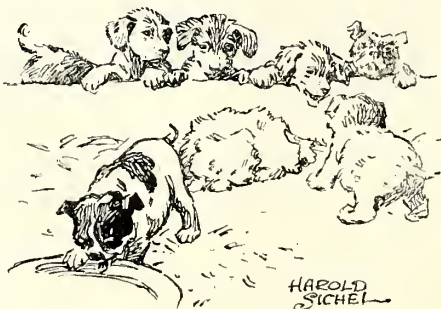

HAROLD SICHEL

# THE WORKSHOP OF THE MIND

By HALLAM HAWKSWORTH

## CHAPTER IV

### THE WINGS OF THE MIND

ONCE upon a time, there was born a horse with wings. Although he was n't what you might call a real horse, he not only outlived all the horses of his generation, but the untold millions of horses that since that time have carried man along the highways of the world and plowed his fields. Indeed, it was just because he was n't "real" in the ordinary sense, but yet much more "real" than horses of flesh and blood, in another sense, that he lived so long. In this sense, the wonderful creature I am speaking of was as real as rain, or Homer's Iliad, or the law of gravitation, or the rule of three.

To those who know how to call him up from the pastures, he answers to the name of Pegasus and is the ready servant of that remarkable faculty of the mind we call "Imagination"; the faculty that gave us the fairy stories of our younger days, and "Robinson Crusoe" and "Mid-Summer Night's Dream," and locomotives and picture-books, and lead-pencils with rubber erasers on one end.

Pegasus, to be sure, has come to be particularly identified with flights of the poetic imagination. But this is a comparatively modern idea which was unknown to the ancients, among whom he seems to have been a horse of all work. His original owner, Bellerophon, for example, used him as a war-horse, and he later carried lightning for Zeus; an episode in his career, by the way, which is very suggestive of his later service for Mr. Morse, Mr. Edison, and others, is n't it? In this chapter we shall treat him as representing the imaginative faculty in general, how it works in the minds of the great, and so how it can best be made to work in ours. For all minds act on the same principles, just as all eyes and all hands are built on the same general pattern and work in the same general way.

#### I. HOW PEGASUS PUTS ON HIS WINGS

So you see how nicely that fine old Greek story of the winged horse is turning out. Every one of us has a Pegasus of his own! They are only colts, to be sure, some of them, these Pegasuses, but now is the very time to begin training them.

Like any other horse, Pegasus must be fed and he must have lots of exercise. Listen:

Oh, it came o'er my ear like the sweet south  
That breathes upon a bank of violets,  
Stealing and giving odor!

Do you smell the violets? No? Then try this:

Freeze, freeze, thou bitter sky,  
Thou dost not bite so nigh  
As benefits forgot!

And this:

While the plowman near at hand  
Whistles o'er the furrowed land,  
And the milkmaid singeth blithe  
And the mower whets his scythe.

And this from Longfellow:

Silently, one by one, in the infinite meadows of  
heaven,  
Blossomed the lovely stars, the forget-me-nots  
of the angels.

Or these seven words from Stevenson: "It was a clear night of stars."

Did you feel chilly? Or see the plowman, and hear his whistle and the voice of the milkmaid and the ring of the whetstone on the scythe? Or did you see the vast night sky and the stars?

No? Then your Pegasus needs exercise. Listen again—just one more:

Even while I live in darkness and silence, I can bring out colors in memory if I wish, and discern between black and white and whatever others I wish; nor yet do sounds break in and disturb what is drawn in by mine eyes, and which I am considering, as it were, apart—for these, too, I can summon if I please, and immediately they appear. And though my tongue be at rest and my throat silent, yet can I sing as much as I will. . . . So the remaining things carried in and heaped up by the other senses I recall at my pleasure. And I discern the scent of lilies from that of violets, while smelling nothing.

The voice sounds strange—does n't it?—and the words? Through the magic of the printed page, it comes to us across eighteen centuries of time. It is the voice of St. Augustine. He had trained his imagination to that degree.

Some people say poetry has n't the same place in life it once had, because this is pre-eminently an age of science, and that science is hostile to poetry. Don't you believe a word of it! The fact is, the grand truths of science open up fields for poetry and the culture of the imagination that the Greeks never dreamed of, because they did n't have the facts to dream with. Are you studying



astronomy? Then listen to this from a prize poem that Tennyson wrote during his student days at Cambridge. Soaring in imagination among the worlds, he says:

I saw

The smallest grain that dappled the dark Earth,  
The indistinctest atom in deep air.  
The moon's white cities and the opal width  
Of her small, glowing lakes, her silver heights  
Unvisited with dew of vagrant cloud  
And the unsounded, undescended depth,  
Of her dark hollows. The clear galaxy  
Shorn of its hoary luster, wonderful,  
Distinct, and vivid with sharp points of light,  
Blaze within blaze, an unimagined depth  
And harmony of planet-girded suns  
And moon-encircled planets, wheel in wheel.

That's astronomy—the real thing! not a mere dead catalog of scientific facts. Whoever fails to see poetry and art and mathematics and engineering—imagination in all its forms—in nature, does n't see nature at all. The mere knowledge of the facts of science, without imagination, is little more than the time-table to a railroad-train. It merely tells you how to go. Pegasus knows the way.

As we read those lines of the brilliant young student, do we need to be told that he had fed his imagination well on the science of the day? At the time, he was particularly interested in astronomy, including the much debated question whether there is anybody at home in Mars and other world-neighbors. Following the last line I have quoted, he says:

Nay, the hum of men  
Or other beings talking in unknown tongues,  
And notes of busy life in distant worlds  
Beat like a far wave on my anxious ear.

All through his poems there are allusions showing his deep interest in astronomy, botany, ornithology, entomology,—to call them by their scientific names,—and in politics and political economy. In short, like all great artists, his life and thought felt the touch of the life and thought of his time.

And we don't know science until we know and feel it as he knew and felt it; until we can see "the bracken rusting on the crag"; the red anemone burning through the lush, green grasses; until, in imagination, by the margin of the pond we can see where "the gold-lily blows"; and in the woods "the wandering ivy and vine . . . garlanding the gnarled boughs . . . with bunch and berry and flower," and "in many a wild festoon . . . swaying" this way and that with the rising wind.

That's botany as the seers see it; the poets and painters, with words or pencils or brushes

—the Ruskins, the Kiplings, the Turners, the William Hamilton Gibsons. It's botany set to music, as the lines previously quoted were astronomy set to music.

And this is how the worms complete "the process of metamorphosis" of the text-book:

Upon some earth-awakening day of spring  
They pass from gloom to glory, and aloft  
Winnow the purple, bearing on both sides  
Double display of scarlet wings, which burn  
Fanlike and fibered, with intensest bloom.

If there's anything that takes the life and poetry out of bugs or butterflies or flowers or stars or anything, it's to shut them up in a text-book and then leave them in the school-room. The old text-books and the old schools did that. The modern text-book and, above all, the modern teacher, and many mothers and some fathers whom I know, put the flowers back in the fields and the stars in the sky and the insects in their native lands, and then, with the poets and the artists, go out and study them.

The great men of science, like the poets, are men of powerful and well-informed imaginations. "The eye," says Tyndall, "can not see sound-waves contract and dilate, but we construct them in thought." And the imagination of the scientist, like that of the poet, often makes him a seer, a foreseer, a prophet. As his mind wings its way in the wide fields of thought, he often *sees* great truths before he can *prove* them. It was so with Newton's discovery of the law of gravitation, and of Darwin's discovery of the law of evolution. But in discovering great scientific truths, as in writing good poetry or designing a Brooklyn Bridge, the mind must be informed and trained.

It was because of the necessity of fortifying the imagination with facts, that Darwin took years to collect his facts and turn his conclusions over and over in his mind, after the great secret of the origin of all forms of life first flashed upon him, before making it public. After Newton's first conception of that vast idea of the machinery of the worlds, he worked on it for years and then abandoned it, because the result of his calculations disagreed with his observations; he just *could not* get the great problem to come out right! Then, having obtained from Paris certain information which he lacked, he went at it again and proved the truth of the vision as his mind had seen it, of a sudden, soaring on the wings of imagination among the worlds—the day the apple fell, as tradition says, in his back garden at Woolsthorpe.

Odd sort of horse, this Pegasus, in many ways. He won't go, to amount to anything, he won't get anywhere in particular, until he is saddled and bridled and you are firm in your seat. He thrives on work, as real horses thrive on oats. Work is to him what oats and corn and good sweet hay are to horses of flesh and blood. At times, he insists on your giving him therein—as Newton did that day in the garden; at others, you must rein him in. But the strangest thing of all is that the bigger the load you put on him, within his carrying powers, the higher he rises and the farther he goes!

"Genius in whatever field," says Ruskin, "is always distinguished by its perpetual, well-directed and faithful labor in accumulating material and disciplining its powers."

"Genius," says Edison, "may be one part inspiration, but it is certainly nine parts perspiration."

## II. HOW PEGASUS TAKES FLIGHT

SOME of these modern investigator people who have been making it a business to go about taking little George Washington's hatchet away from him, and the egg away from Columbus, and in general demanding the passports and credentials of good stories about great people that have come over to us from other days, are even beginning to say that the story of Newton's apple is a myth. This sort of thing used to annoy me immensely, when I was a boy, but I soon learned that where one of these stories was sent back among the myths, it was often replaced by some authenticated fact that was not only much more interesting, but much more valuable. In the case of the episode in the famous Newton's garden, we are now told that it was not a real apple but a "psychological" apple, that caused the first flash of the law of gravitation in the philosopher's mind. As Edgar James Swift expresses it in "Psychology and the Day's Work":

The story of Newton and the falling apple is historically a myth, but psychologically it is true. It represents the way in which a great mind acts. Things are continually happening that are loaded with suggestive meanings, but only the intellectual prepared can interpret them.



EDISON AT THE CLOSE OF FIVE DAYS AND NIGHTS OF CONTINUOUS WORK IN PERFECTING THE EARLY WAX CYLINDER TYPE OF PHONOGRAPH—JUNE, 1888

Sir William Rowan Hamilton, the astronomer and geometrician, says that one of the discoveries with which his name is identified burst on him one day completely finished, while he was near a bridge in Dublin. Darwin, after years of observation in the fields of natural science, the outgrowth of beetle collecting and like boyish pursuits, accidentally picks up and reads a book that has nothing to do with natural science, Malthus on Population and the world struggle for bread, and behold the law of evolution flashes into his mind, using the material of all those years of observation as fuel to light it into view!

Strange enough that such an incredible secret,—beyond the wildest dreams of the myth-makers,—such an unlikely, unpredictable thing as this marvelous law of change, hidden away, as it was, among the endless complexities of animal and vegetable life, as we see them around us to-day, should have been found out at all.

But as if to make it stranger still, we find another man, Alfred Russel Wallace, who, like Darwin, got his education in the woods and fields, and, like him, grew up to be one of England's great scientists, coming to



the very same conclusion, wholly independent of Darwin, and as a result of the very same chance straying off in his own mind from the main highway of his thoughts, up the lane that led to the corner of that old wood-lot we call Political Economy, where Mr. Malthus had left his theories to dry some fifty-odd years before. It was upon a certain day when he was lying muffled in blankets in an attack of

chills and fever in one of the Spice Islands of the Dutch East Indies, thousands of miles away. He had been thinking about the puzzle as to how there came to be so many forms of life, and he had been reading Malthus, too; and into his mind, in the midst of the shivering, flashed the very same conception of the very same law—the law

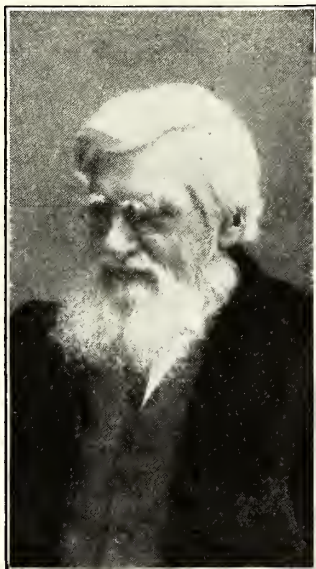

Courtesy of Dodd, Mead & Co.

ALFRED RUSSEL WALLACE

that confirms and explains the extraordinary fact that starfish and statesmen, kittens and crocodiles, elephants and butterflies, possibly even cabbages and kings, are all blood relations, all descended from some Adam, some common ancestral germ in the dawn of life upon this planet, and, as time went on, growing more and more different, each developing its own species.

But this independent discovery by two men of the same great truth, under similar conditions, only goes to show how obedient to law is this apparently most wayward process of the human mind we call Imagination. Let the mind be trained in working and thinking along certain lines, on subjects on which it is well informed, and something is pretty sure to come of it,—often something pretty big, and often as the result of apparent accident,—some message out of the heart of life, unintelligible to minds less prepared to receive it. Every day there are things all around us, no doubt, that are trying to tell us secrets worth knowing, but only those who go to school to the nature of things, as Shake-

spere did, as Tennyson and Newton and Darwin and Wallace did, and as Edison does, can hear them or make out what they say.

Remember the Boy Scout motto, "Be Prepared!"

But don't think that all the ideas of the men of genius come to flower. Edison says he always has his suspicions of anything that works right the first time. It usually has some big trouble for you up its sleeve. The achievements of the famous astronomer Kepler furnish a striking example of the error of assuming that genius has an unerring method of divining truth. His contributions to our knowledge of the orbits and motions of the worlds are so great that we might easily suppose he possessed such a method. But we find that he had many strange views and made many mistakes. His theories, what are called "working hypotheses," were often wild guesses, but he was relentless in trying them out. He took nothing for granted. He was as persistent as young Edison was in asking questions of his teacher, so that she came to the conclusion that the future "wizard" was "addle-pated"—that he kept on asking questions because he could n't understand; whereas he was simply determined to get to the bottom of the thing.

"In all probability," says Jevons, "the errors of great minds excel in number those of the less vigorous. Fertility of imagination and an abundance of guesses at truth are among the first requisites of discovery."

Once upon a time, the great Michael Faraday, the brilliant boy whom Sir Humphry Davy called "his greatest discovery," had a little conversation with himself on this subject of imagination as an aid to science. "Let us," he wrote in his notes, "encourage ourselves with a little more imagination, prior to experiment. Let the imagination go, guarding it by judgment and principle, holding it in and directing it by experiment."

Pasteur even went so far as to say that the experimenter's very illusions are a part of his power; emphasizing the rightness of the right thing, when they finally get to it, by the wrongness of the wrong thing, I suppose!

As the proverb goes, "Nothing succeeds like success"; but it is more fundamentally true that nothing succeeds like failure, if accompanied by the persistent enthusiasm which is characteristic of the successful man. It has been said, and wisely said, that the man who never makes any mistakes, never makes anything. Don't you remember the remark

in Chapter I about those much inquiring ancients who, with no help from books or the stored-up knowledge we carry around in our school-straps, were always prying into the where and whence and how of things? "What if they did think wrong? The great point is that they thought!" And thus, step by step, and century after century, they made the discoveries that mark the path of human progress. Much as the short years of boyhood unconsciously rehearse the story of the civilization of the race,—the cave-dwelling period, the long ages when men lived by the hunt, the crude beginnings of the tool-using period, etc.,—so the workings of the individual mind rehearse, in the "assembly halls" of the brain, the history of the mind of the race through its long ten thousand years.

But let us see what are some of the other conditions under which the imagination does its best work. First and foremost, you must be very much interested in what you are doing. The mere reaching out toward the goal stimulates the imagination immensely.

"How wonderful that you should ever have discovered this thing you call the law of gravitation!" exclaimed a lady of title to Sir Isaac Newton. "How did you do it?"

"By constantly thinking about it, your ladyship," said Sir Isaac.

Like a pet horse that learns to read his master's mind, Pegasus seems to know when your thoughts are all gathered together for the hunt, and up he comes out of the nowhere and away you go!

That's why so much great work is done at white heat. Once possessed of an idea, the writer, the inventor, wants to go on while he is in the mood, and often works to all hours, as Edison does. Goethe, speaking of the conditions under which "Faust," which occupied him for sixty years, full of interruptions and gaps, was composed, said:

The difficulty has been to get, through strength of will, what is best got only by a spontaneous act of nature.

But as "Faust," for all that, has placed the name of Goethe among the immortal "five that the centuries survive," it is plain that the best efforts of the mind are not by any means necessarily the product of inordinately long or irregular hours or the result of chance moods. Dickens, one of the most imaginative of writers, was as regular as a clock. Goethe was methodical in his habits, and so, probably, was Shakespeare. He seems to have been as well-balanced and wholesome an Englishman as you can imagine.

A wholesome mental balance, mingling as a natural man with one's own kind, the rest and stimulation of music and the conversation and companionship of friends, the setting apart of regular hours for recreation as well as for work, was one of the great secrets of the unparalleled achievements of the Greeks. Physical and mental health were essential features of their religion, and "Nothing in excess" was one of their proverbs.

No doubt you've noted how Father, when he gets into a brown study, fixes his eye on something—a pattern in the rug, a picture on the wall, the toe of his slipper. Well, Immanuel Kant, whose philosophy ranks him with the great thinkers of all time, used, when he began work,—it was every morning at five, almost to the tick of the clock,—always to sit so that his eye fell on a certain old tower. This tower became so necessary to his thinking, that when some poplars grew up and hid it from sight, he found himself unable to think at all, until, at his earnest request, the trees were trimmed and the tower brought into view again. Fixing the eye on some object, whenever we have something on our minds and "don't know just what to think about it," as we say, seems to help hold the problem or idea steadily in place; and related ideas and facts, already in our minds, gather around it, much as matter in solution in a liquid crystallizes around a fixed object placed in it.

So of many other peculiarities of eminent men—they are n't so very peculiar after all; and, what is the most important thing for us to remember, they go to show that their minds, even in these apparent eccentricities, are like ours. Dickens used always to write on a little sloping desk that he could set on the top of a table, and whenever he went to the Continent to write, as he sometimes did, he took this desk with him. On either side of it he kept two quaint little figures, such as you often see on people's desks or on dressers, and wherever he went to do his work, these figures were as sure to go as the little lamb was to follow Mary. Blue ink and a quillpen—these also, he always had to have. Writers often feel that they must have a certain kind of paper, of a certain size, of a certain color, even, and a certain kind of pen before they can do a thing.

But in all this, particularly in the attachment to a special pen, they don't differ from other people who do other kinds of writing. You'll never find a book-keeper who does n't insist on the exact brand of tool he is used to.



As for the attachment to the little figures, this is often spoken of as if it were a kind of superstition; but the figures were simply a part of the surroundings that made his Pegasus feel at home and turn in at the familiar gate.

One of the strangest ways of calling up Pegasus, of stimulating the imagination, was

him of the tinkle and plash of that fountain in the old Italian garden!

One day the janitor comes plodding up the stairway, and, discovering the running tap says, "I 've been pumpin' water up here for three weeks and wonderin' where in blazes it was a-goin'." Young man, you 'll have to cut that out."



BEETHOVEN LISTENING TO THE STORM

*Beethoven was passionately fond of Nature and much of his music was as much an interpretation of Nature's moods as are Corot's landscapes. Most of his greatest works were conceived on lonely walks in the country. Like the painter, he always carried a note-book with him and put down in musical characters the thoughts that were suggested to him by the scenes and sights around him. There are constant alterations in his note-books, showing the infinite pains he took in working up his compositions out of the ideas as they first occurred to him; and it is a striking example of the truth which Edison put in homely phrase, "inspiration is nine-tenths perspiration," that some of Beethoven's most marvelous compositions were developed from rather ordinary conceptions.*

that employed, once upon a time, by our great American sculptor, St. Gaudens. You will find the story in his reminiscences. When he was in Rome, during his student days, he was very fond of strolling about at night in one of the old Italian gardens, in which there was a fountain which was particularly beautiful in the moonlight and played such music as only a fountain in an old Italian garden can play. So when St. Gaudens got back to New York City and into his humble little studio on the third floor back, what does he do but turn on the water-tap and keep it running all day long to remind

Many distinguished men have found music an inspiration. Milton relied on the organ to produce the mood for composition; and perhaps it 's some of this music we hear in the stately measures of "Paradise Lost."

But the most significant thing about the development of the minds of great men and their methods, a thing that points plainly to what we ought to get from our own reading, is the stimulation and direction they found for their own life-work, in the work of the great men they themselves admired, lighting their own torches at another's flame. Gray never sat down to write without previously,

and for a considerable time, reading in the works of Spenser. Corneille and Racine, the great French dramatists, read their favorite authors in the same way and for the same purpose. Lord Erskine, the greatest of all orators of the bar, used to read Edmund Burke's speeches again and again, and he knew Milton's "Paradise Lost" and much of Shakespeare by heart. Lincoln, when he was a boy, used to pore over the speeches of Clay which were published in the newspapers.

Tennyson, as a boy, was fired with admiration for Byron, and on hearing of his death, "a day," as he afterward said, "when the whole world seemed darkened," he carved the words, "Byron is dead," on a block of sandstone near the spring of Holywell.

Dickens, in turn, drew inspiration from Tennyson. "I have been reading Tennyson all the morning on the seashore," he wrote to a friend. And as a result, he said he could see, in imagination, "all the mermen and mermaids at the bottom of the ocean."

Conversation with friends, the sympathetic contact of mind with mind, has al-

ways been a great source of inspiration with successful men in all lines—writers, artists, orators, inventors, musicians; and conversation and friendship, which were so fundamental in the culture of the Greeks, were, as I said a moment ago, among the chief sources of their marvelous achievements. The well-known picture of Alma-Tadema, "A Reading from Homer," might be said, almost, to sum up the great features of their civilization. It shows one of their beautiful circular benches which drew little groups together and made conversation so inviting; the lyre in the background typifies their music and their musical language; the scroll from which the handsome youth is reading, may be taken as symbolic of their invention of, and brilliant distinction in, every form of literature.

And the best of it is that these greatest of stimulants to the imagination and the growth and achievements of the mind in all its great capacities—the friendship of the living and, through the printed page, the friendship of the immortal dead—are free to all of us, now and all the time.

## THE MERRY-GO-ROUND

By CLINTON SCOLLARD

IN all my life I 've never found  
 So merry a thing as the merry-go-round;  
 For there the beasts come every day  
 From far away as Africa,  
 And let you ride them to the sound  
 Of some old wheezy, breezy thing  
 That makes what 's called "the welkin" ring.

I feel my jumping heart rejoice  
 Of these big beasts to have my choice;  
 The elephant and tall giraffe  
 Both look so queer I have to laugh.  
 And there 's a tiger with no voice—  
 I think he must have left it where  
 He lived within his jungle lair.

It is my greatest joy and pride  
 Upon the lion's back to ride;  
 And, like the tiger, if he had  
 A shaggy, wide-mouthed roar when mad,  
 He keeps it safely hid inside.  
*In all my life I 've never found  
 So merry a thing as the merry-go-round!*



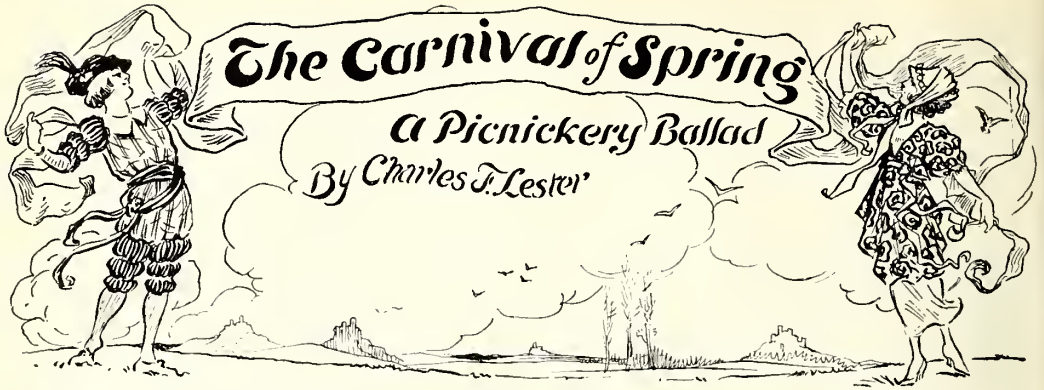

IN the happiest of humors and his suit of peacock blue,  
 Down a stately steep stone stairway tripped the gay Sir Gigaboo,  
 ('T is well Sir Bobus, waiting down below, was good and plump,  
 Or, when he tripped, Sir Gigaboo 'd have gotten quite a bump!)

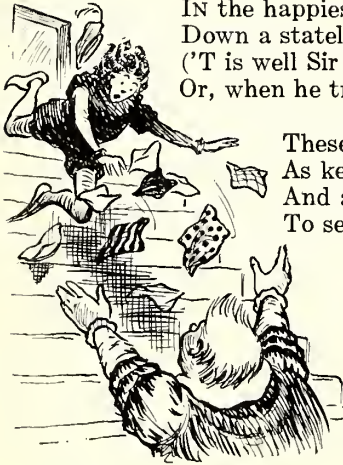

These twain had been appointed, by order of the king,  
 As keepers of the bean-bags in the Carnival of Spring;  
 And as they passed the castle gate, with joyous whoop and shout,  
 To see them off and cheer them on, the inmates all came out.

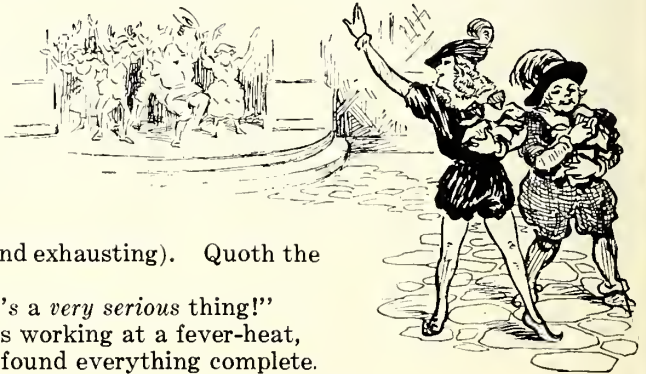

The plans were most exhaustive (and exhausting). Quoth the king:  
 "Gadzooks! You know a *carnival's* a *very serious* thing!"  
 But with twenty-three committees working at a fever-heat,  
 The festal day (the first of May) found everything complete.

A grassy greensward, good for games, was gay with gamboling groups.  
 Lady Maude and Lady Edith were rolling striped hoops;  
 Lord Pimpernel had organized a game of "Prisoner's Base";  
 And Lady Jane was pogo-ing with most consummate grace.





Sir Boofus could be seen see-sawing on a see-saw. "See! Its motion 's like the ocean's, to my notion," said Sir B. Sir Wibble threw a bean-bag (with the accent on the "bean"); Sir Wobble got a headache; and Sir Wibble fled the scene!

Beside a lovely lake a lunch was lavishly laid out;  
But let 's not linger o'er it (though dozens did, no doubt);  
Count Zam accounted for five tarts; the Lady Kate, 't would seem,  
Was quite insatiate—they say she ate eight plates of cream!

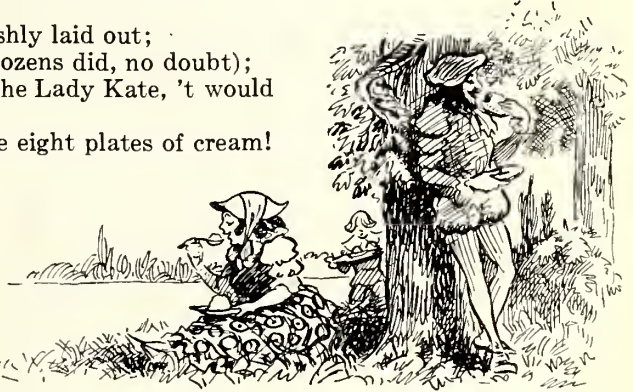

A fairy play, "The Queen of May," was given on the green;  
Lord Whing-Whang wrote it (with one hand!). His daughter played the queen.

Sir Gubbe, the "Ogre," was immense; till by a sad mischance  
His mask fell off (which put Sir Gubbe quite out of countenance!)



Lady Floppe's "Symbolic Dance" (which did n't symbolize a thing)  
Was followed by an "Ode to May," recited by Lord Ping.  
At verse nineteen the king went sound asleep, I grieve to say,  
But woke at forty (so he heard the last ten, anyway).



Well, now the program 's all run off, so why should I run on?  
And if your patience has run out—cheer up! My tale is done,  
And now, let 's give those twenty-three committees of the king  
A vote of thanks for getting up The Carnival of Spring!





# THE BLUE ENVELOP

By ROY C. SNELL

## CHAPTER V

### THE WHITE LINE

OUT on the wreck, some two hundred yards from shore, a figure emerged from a small cabin aft. The stern of the ship had been carried completely about by the violence of the waves. It had left this little cabin, formerly the wireless cabin, high and dry.

The person came out upon the deck and scanned the horizon. Suddenly his eyes fell upon the cabin and the strange white signal which the girls had set fluttering there before they went to sleep.

Sliding a native kayak down from the deck, he launched it, then, leaping into the narrow seat, began paddling rapidly toward land.

Having beached his boat, he hurried toward the cabin. His hand was on the latch when he chanced to glance up at the white emblem of distress which floated over his head.

His hand dropped to his side; his mouth flew open. An expression of amazement spread over his face.

"Jumpin' Jupiter!" he muttered beneath his breath.

He beat a hasty retreat. Once in his kayak he made double time back to the wreck.

Marion was the first to awaken in the cabin. By the dull light that shone through the cracks, she could tell that it was growing dark.

Springing from her bunk, she put her hand to the latch. Hardly had she done this when the door flew open with a force that threw her back against the opposite wall. Fine particles of snow cut her face. The wind set every loose thing in the cabin bobbing and fluttering. The skirt they had attached to a stout pole as a signal was booming overhead like a gun.

"Ah! A blizzard!" she groaned.

Seizing the door, she attempted to close it. Twice, the violence of the storm threw her back.

When at last her efforts had been rewarded with success, she turned to rouse her companion. "Lucile! Lucile! Wake up! A blizzard!"

Lucile opened her eyes.

"Wha—wha—" she droned sleepily.

"A blizzard! A blizzard from the north!" Lucile sat up quickly.

"From the north?" she exclaimed, fully awake in an instant. "The ice?"

"Perhaps."

"And if it comes?"

"We're stuck in Siberia, that's all, for eight or nine months. We won't dare try to cross the straits on the ice. No white man has ever done it, let alone a woman. Well," she smiled, "we've got food for five days, and five days is a long time. We'd better try to bring in some wood and get the dogs in here; they'd freeze out there."

Three days the blizzard raged. Such a storm at this season of the year had not been known on the Arctic for twenty years.

The third day broke clear and cold, with the wind still blowing a gale. Lucile was the first to throw open the door. As it came back with a bang, something fell from the beam above and rattled to the floor.

She stooped to pick it up. "Look, Marion!" she exclaimed, "A key! A large brass key!"

Marion examined it closely. "What can it belong to?"

"The wreck perhaps. Looks like a steward's pass-key."

"But what would they save it for? You don't think—"

"If we could get out to the wreck, we'd see."

"Yes, but we can't. There—"

"Look, Marion!" Lucile's eyes were large and wild.

"The white line!" exclaimed Marion, gripping her arm.

It was true. Before them lay the dark ocean still flecked with foam, but at the horizon, gleaming whiter than burnished silver, straight, distinct, unmistakable, was a white line.

"And that means—"

"We're trapped!"

Lucile sank weakly into a chair. Marion began pacing the floor.

"Anyway," she exclaimed at last, "I can paint it! It will make a wonderful study."

Suiting action to words, she sought out her paint-box and was soon busy with a sketch, which, developing bit by bit, or rather, seem-

ing to evolve out of nothing, showed a native dressed in furs, shading his eyes to scan the dark, tossing ocean. And beyond, the object of his gaze, was the silvery line. When she had finished, she playfully inscribed a title for the sketch at the bottom—"The Coming of the White Line."

For a moment she stood there thinking of the possibilities of a winter in this terrible land. Suddenly a glimmer of hope shot in out of the darkness—the strange, brown boy who had come to them out of the sea that day on Mutineer's Island! The scientist had said that he had probably been brought from somewhere to the north of Russia. If he should cross their path now, they would at least feel that, in all this wilderness, they had one friend. Then, with a smile, she realized how wildly improbable was the thought. To build a hope upon such a remote chance seemed utterly absurd.

As she put her paints away, something caught her eye. It was one corner of the blue envelop with the strange address upon it.

"Ah, there you are still," she sighed. "And there you will remain for nine months, or I miss my guess. I wish I had n't kept my promise to the boy—wish I'd left you in the pigeonhole at Cape Prince of Wales."

Since the air was too chill, the wind too keen for travel, the girls slept that night in the cabin.

They awoke to a world unknown. The first glimpse outside the cabin brought surprised exclamations to their lips. The "white line" was gone. So, too, was the ocean. Before them, as far as the eye could see, lay a mass of yellow lights and purple shadows, ice-fields that had buried the sea.

Only one object stood out black and bare before them—the hull of the wrecked ship.

"Look!" said Lucile, suddenly. "We can go out to the ship over the ice-floe!"

"Let's do it," said Marion, eagerly.

They were soon threading their way in and out among the ice-piles, which were al-



"'THE WHITE LINE!' EXCLAIMED MARION, GRIPPING HER ARM"

ready solidly attaching themselves to the sand beneath the shallow water.

And now they reached a spot where the water was deeper; where ice-cakes, some small as a kitchen floor, some large as a town lot, jostled and ground one upon another. They were only half-way to the wreck.

"Wo-oo, I don't like it!" exclaimed Lucile, as she leaped a narrow chasm of dark water.

"We'll soon be there," trilled her companion. "Just watch your step, that's all."

They pushed on, leaping from cake to



cake, or racing across a broad ice-pan, now skirting a dark pool, now clambering over a pile of ice ground fine, as they made their way slowly, but surely, toward their goal.

"Listen!" exclaimed Marion.

"What is it?" asked Lucile, her voice quivering with alarm.

A strange, wild, weird sound came to them across the floe—a grinding, rushing, creaking, moaning sound, that increased in volume as the voice of a cyclone increases.

Only a second elapsed before they knew. Then with a cry of terror, Marion dragged her companion to the center of the ice-pan and pulled her flat to its surface. From somewhere, far out to sea, a giant tidal wave was sweeping through the ice-floe. Marion had seen it. The mountain of ice which it bore on its crest seemed as high as the solid ridge of rock behind them on the land. And with its weird, wild, rushing scream of grinding and breaking ice, it was traveling toward them. It had the speed of the wind, the force of an avalanche. When it came, what then?

With a rush, the wild terror of the arctic sea burst upon them. It lifted the giant ice-pan weighing hundreds of tons, tilted it to a dangerous angle, then dropped from beneath it. Marion's heart stopped beating, as she felt the downward rush of the avalanche of ice. The next instant she felt it crumble like an egg-shell. It had broken at the point where they lay. With a warning cry of terror, she sprang to her feet and pitched backward.

The cry came too late. As she rose unsteadily to her knees, she saw a dark brown bulk topple at the edge of the cake, then roll with a swash into the pool of water which appeared where the cake had parted. It was Lucile! She had fallen into the stinging arctic brine. What chance could there be for her life?

For the time being, the ice-field was quiet. The tidal wave had spent its force on the sandy beach.

That other, less violent, disturbances would follow the first, the girl knew right well. Hastily creeping to the brink of the dark pool, she strained her eyes for the sight of floating bit of cloth, a waving hand. There was none. Despair gripped her heart. Still she waited, and, as she waited, there came the distant sound, growing ever louder, of another onrushing tide.

When Lucile went down into the dark pool she was not only conscious but very much

alive, and acutely aware of the peril of her situation. Should that chasm close before she rose, or as she rose, she was doomed. In one case she would drown; in the other, she would be crushed like a barnacle between ocean liners.

Down, down she sank. But the water was salt and buoyant. Now she felt herself rising. Holding her breath, she looked upward. A narrow ribbon of black was there to the right.

"That will be the open water," was her mental comment, "I must swim for it."

She was a strong swimmer. Her heavy fur garments impeded her. The sting of the water imperiled her power to remain conscious. Yet she struggled even as she rose.

Just when Marion had given up hope, she saw a head shoot above the water, then a pair of arms. The next instant she gripped both her companion's wrists and lifted as she had never lifted before. There was wild terror in her eyes. The roar of the second wave was drumming in her ears.

She was not a second too soon. Hardly had she dragged the half-unconscious girl from the pool, than it closed with a grinding crash, and the ice-pan again tilted high in air.

The strain of this on-rush was not so great. The cake held together. Gradually it settled back to its place.

Marion glanced in the direction of the wreck. They were very much nearer to it than to the shore. She thought she saw a small cabin in the stern. Lucile must be relieved of her salt-water-soaked and fast-freezing garments at once.

"Can you walk?" she asked.

Lucile staggered dizzily to her feet.

"I 'll help you. The wreck! We must get there. You must struggle or you 'll freeze."

Lucile did try. She strove as she had never done before—against the stiffening garments, the aching lungs and muscles, but most of all against the almost unconquerable desire to sleep.

Foot by foot, yard by yard, they made their way across the treacherous tangle of ice-piles, which was still in restless motion.

Now they had covered a quarter of the distance, now half; now three quarters; and now, with an exultant cry, Marion dragged her half-unconscious companion upon the deck.

"There 's a cabin aft," she whispered, "a warm cabin. We 'll soon be there."

"Soon be there," Lucile echoed faintly.

The climbing of the long, slanting, slippery deck was a terrible ordeal. More than once Marion despaired. At last they stood before the door. She put a hand to the knob. A cry escaped her lips:

"Locked!" Dark despair gripped her heart. But only for an instant. "Lucile, the key! The key we found in the cabin! Where is it?"

"The key—the key?" Lucile repeated dreamily.

"Yes, the key! The key!"

"Oh, yes, the key. Why, that 's of no use."

"Yes, it is! It *is*!"

"It 's in my parka pocket."

The next moment Marion was prying the key from a frozen pocket, and the next after that she was dragging Lucile into the cabin.

In one corner of the cabin stood a small oil-heater. Above it was a match-box. With a cry of joy, Marion found matches, lighted one, tried the stove, found it filled with oil! A blaze rewarded her efforts. There was heat; heat that would save her companion's life.

She next attacked the frozen garments. Using a knife where nothing else would avail, she stripped the clothing away until at last she fell to chafing the white and chilled limbs of the girl who still struggled bravely against the desire to sleep.

A half-hour later Lucile was sleeping naturally in a bunk at the upper wall of the room. She was snuggled deep in the interior of a mammoth deer-skin sleeping-bag. Her garments were drying beside the kerosene stove. Marion was drowsing half asleep by the fire.

Suddenly, she was aroused by a voice. It was a man's voice. She was startled.

"Please," the voice said, "may I come in? That 's supposed to be my cabin, don't you know? But I don't want to be piggish."

Marion stared wildly about her. For a second she was speechless. Then she spoke: "Wait—wait a minute; I 'm coming out."

## CHAPTER VI

### THE BLUE ENVELOP DISAPPEARS

WHEN Marion heard the voice outside the cabin on the wreck, she realized that a new problem, a whole set of new problems, had arisen. Here was a man. Who was he? Could he be the grizzled miner who had demanded the blue envelop? If so, what then? Was there more than one man? What was to come of it all, anyway?

All this sped through her mind while she

was drawing on her parka. The next moment she had opened the door, stepped out, and closed it behind her.

"Ah! I have the pleasure—"

"You?" Marion gasped.

For a second she could say no more. Before her, dressed in a jaunty parka of Siberian squirrel-skin, was the frank-faced college-boy—he of the Phi Beta Chi.

"Why, yes," he said rather awkwardly, "it is I. Does it seem so strange? Well, yes—I dare say it does. Suppose you sit down and I 'll tell you about it."

Marion sat down on a section of the rail.

"Well, you see," he began, a quizzical smile playing about his lips, "when I had completed my—my—well, my mission to the north of Cape Prince of Wales, it was too late to return by dog-team. I waited for a boat. I arrived at the P. O. you used to keep. You were gone. So was my letter."

"Yes, you said—"

"Now, now, don't interrupt. That was quite all right; the thing I wanted you to do. But, you see, that letter is mighty important. I had to follow. This craft we 're sitting on was coming this way. I took passage. She ran into a mess of bad luck. First we were picked up by an ice-floe and carried far into the Arctic Ocean. When at last we poled our way out of that, we were caught by a storm and carried southwest with such violence that we were thrown upon this sand-bar. The ship broke up some, but we managed to stick to her until the weather calmed. We went ashore and threw some of the wreckage into the form of a cabin. You 've been staying there, I guess." He grinned.

Marion nodded.

"Well, the ship was hopeless. Natives came in their skin-boats from East Cape."

"East Cape? How far—how far is that?"

"Perhaps ten miles. Why?" He studied the girl's startled face.

"Nothing; only did n't a white man come with the natives?"

"A white man?"

"I 've heard there was one staying there."

"No, he did n't come."

Marion settled back on the rail.

"Well," he went on, "the captain of this craft traded everything on board to the natives for furs; everything but some food. I bought that from him. You see, they were determined to get away as soon as possible. I was just as determined to stay. I did n't know exactly where you were, but was bound I 'd find you—and the letter." He paused.



"By the way," he said, struggling to conceal his intense interest, "have you the letter?"

Marion nodded. "It is in my paint-box over in the cabin."

The boy sprang eagerly to his feet. "May we not go fetch it?"

"I can't leave my friend here alone."

"We had no such intention when we came, but the storm and the white line caught us. No more boats now."

"Say," he exclaimed, "you two can keep my cabin! There's a bunk below the deck where I can be quite comfortable." He did not wait for her reply. "I'll go for your things. You stay here. Any dogs?"

"Three."

"Good! I'll be back quicker than you think."

He was away. Bounding from ice-cake to ice-cake, he soon disappeared.

Marion reëntered the cabin, and sat there for a time, thinking. Then she fell to wondering if the boy had reached the shore safely, so she went outside again and climbed to the highest point on the rail. There she stood for some time, scanning the horizon.

"Strange he'd be way down there!" she murmured, at last; "a quarter of a mile south of the cabin. Perhaps the ice carried him."

The distance was so great she could distinguish no more than a figure, a mere speck, moving in and out among the ice-piles that lined the shore. For a moment she rested her eyes by studying the ship's deck. Then again she gazed away toward the cabin.



"BEFORE HER WAS THE FRANK-FACED COLLEGE-BOY"

"Then may I go?" He was eager as a child. Then, after a second, "Why, by Jove! I'm selfish. Have n't given you a chance to say a thing. Perhaps your friend is in trouble. Of course she is, or she'd be out here. What is it? Can I help you?"

"She's only chilled and recovering from a shock. The tidal wave threw her into the sea."

"Oh!" He stood thinking for a moment. "Do you intend to remain in Siberia all winter?"

"Why!" she exclaimed suddenly, "he has reached the cabin! He must have run every step of the way!"

In the cabin on shore, the young stranger began packing the girls' possessions preparatory to putting them on the sled.

"Some careless housekeepers!" he grumbled, as he gathered up articles of clothing from every corner of the room, and, having straightened out Marion's paint-box, closed its cover down with a click.

He arrived at the schooner an hour later. The sled load was soon stowed away in the wireless cabin.

He brought a quantity of food, canned vegetables, bacon, hard-tack, coffee, and sugar from his store below. Then he stood by the door.

Marion was bustling about the cabin, putting things to rights. Lucile, a trifle pale, was sitting in the corner.

Presently Marion caught sight of him standing there. "Oh!" she exclaimed, "you are waiting for your reward?"

"Any time," he smiled.

"You shall have it right now—the blue envelop."

She seized her paint-box, and, throwing back the cover, lifted the paint-tray. Then from her lips escaped one word; "Gone!"

He sprang eagerly forward.

"It can't be!" Lucile breathed.

"Take a good look," the boy suggested.

Marion inspected the box thoroughly. "No," she said, with an air of finality, "it's not here."

"Your—er—the paint-box," he stammered, "it was a bit disarranged."

"Disarranged?"

"Well, not in the best of order. Letter might have dropped out in the cabin. I dare say it's on the floor back there. Had you seen it lately?"

"Only this morning. I can't understand about the box. The wind must have blown it down, or something."

"I dare say." The boy smiled good-naturedly as he recalled the disordered room.

"I'll hop right back and look for it."

It was with a very dejected air that he returned. Marion could not tell whether it was genuine or feigned. Had he been in such haste to secure the letter that he had taken it at once from the box? Was all his later action mere stage-play?

"No," he said, bringing forth a forlorn smile, "I could n't find it. It's not there."

That evening, when, after a supper served on a small tip-down table in the wireless cabin, the boy had gone to his bunk below and Lucile had fallen asleep, Marion lay awake a long time puzzling over the mysteries of the past and the problems of the future. Where had the blue envelop disappeared to? Did the boy have it? She resolved to search, for herself, the cabin on the beach. She felt half inclined to talk matters over frankly with him. There were mysteries which might be cleared up. She remembered with

what astonishing speed he had reached the cabin, once he had sprung upon the shore. She remembered, too, how he had spoken of the disordered paint-box. She prided herself on her neatness. And that paint-box, was it not her workshop, her prize possession? She longed to talk it over with him. But on the other hand, she could not bring herself to feel that her trust in him was fully warranted. She hated, above all things, to be "taken in." If she discussed all these things with him, and if, at the same time he had the letter, would n't she be taken in indeed?

"No," she pressed her lips tight shut, "no, I won't."

Morning found the boy in a quite different mood. He laughed and chatted gaily over his sour-dough pancakes.

"Now you know," he said, as he shoved back his stool, "I like your company awfully well, and I'd like to keep this up indefinitely; but I've got to get across the straits."

"We'll be sorry to lose you," laughed Marion; "but just you run along. And when you get there, tell the missionary that breakfast is ready. Ask him to step over and eat with us."

"No, but I'm serious."

"Then you're crazy. No white man has ever crossed thirty-five miles of floeing ice."

"There's always to be a first. Natives do it, don't they?"

"I've heard they do."

"I can go anywhere a native can, provided he does n't get out of my sight."

"A guide across the straits! It's a grand idea!" Marion seized Lucile about the waist and went hopping out on deck. "A guide across the straits. We'll be home for Christmas dinner yet!"

"What, you don't mean—" The boy stared in astonishment.

"Surely I do. We can go anywhere you can, provided you don't get out of our sight."

"That—why, that will be dandy."

He said this with lagging enthusiasm. It was evident that he doubted their power of endurance.

"We'll have to go to East Cape to start."

"East Cape?" Marion exclaimed in a startled tone.

"Sure. What's wrong with East Cape?"

"Nothing—only, only that's where that strange white man is."

"What's so terrible about him?"

Marion hesitated. She had come to the end of a blind alley. Should she tell him of



her experiences with the miner who demanded the blue envelop, and of her suspicion that this man at East Cape was that same man?

She looked into his frank blue eyes for a moment, then said to herself, "Yes, I will."

She did tell him the whole story. When she had finished, there was a new, a very friendly light in the boy's eyes.

"I say!" he exclaimed, "that was mighty good of you. It really was. That man—"

He hesitated. Marion thought she was going to be told the whole secret of the blue envelop.

"That man," he repeated, "he won't hurt you. You need have no fear of him. As for yours truly, meaning me, I can take care of myself. We start for East Cape to-day. What say?"

"All right."

Marion sprang to her feet, and, after imparting the news to Lucile, who had by this time fully recovered from the shock of the previous day, set to work packing their sled.

The recent mysterious disappearance of the blue envelop remained unexplained. Under pretense of missing some article from her wardrobe, when on the beach ready to start for East Cape, Marion hastened to the cabin and made a quick search for the missing envelop; but it was unrewarded.

One thing, though, arrested her attention for a moment. As she left the cabin she noticed, near the door, the print of a man's skin-boot in the snow. It was an exceedingly large print, such as is made by a careless white man who buys the first badly-made skin-boots offered to him by a native seamstress. The college-boy could not have made that track. His skin-boots had been made by some Eskimo woman of no mean ability, who had fitted them to his feet, as she would have done for her Eskimo husband.

"Oh, well!" she exclaimed, as she raced to join her companions, "probably some native who has passed this way."

Even as she said it, she doubted her own judgment. She had never in her life seen a native wear such a clumsily shaped skin-boot.

## CHAPTER VII

### THE VISIT TO THE CHUKCHES

It was with a feeling of strange misgiving that Marion found herself entering the native village of East Cape. Questions continually presented themselves to her mind. What of the bearded stranger? Was he the miner

who had demanded the blue envelop? If it were he, if he appeared and once more demanded the letter, what should she say? For any proof ever presented to her, he might be the rightful owner, the real Phi Beta Chi. What could she say to him? And the natives? Had they heard of the misfortunes of the people of Whaling? Would they, too, allow superstitious fear to overcome them? Would they drive the white girls from their midst?

An interpreter was not hard to find at East Cape. Many of the men had sailed on American whalers. They were told by one of these that there was but one man in all the village who ever attempted the dangerous passage of the straits—one O-bo-gok.

O-bo-gok was found sitting cross-legged on the sloping floor of his skin igloo, adjusting a new point to his harpoon.

"You tell him," said the smiling college-boy, "that we want to go to Cape Prince of Wales. Can he go to-morrow?"

The interpreter threw up his hands in surprise, but eventually delivered his message.

The guide, a swarthy fellow, with shaggy, drooping mustache and a powerful frame, did not look up from his work. He merely grunted.

"He say, that one, no can do," smiled the interpreter.

The college-boy was not disturbed. He jingled some coins in his hand.

The man, dropping his harpoon, began to talk rapidly. He waved his hands. He bobbed his head. At last he arose, sprang from the sleeping-compartment, and began to walk the space before the open fire. He was still talking.

When, at last, he had finished and had thrown himself once more upon the floor of the sleeping-room, the interpreter began:

"He say, that one, he say, 'Want 'a go Cape Prince Wales two month, three month, all right, mebbly. Go now? Not go.' He say, that one, 'Want 'a go now; never come back.' He say, that one, 'Two, three, four days come ice. Not plenty ice,' say that one '—some water, some ice. See water. Too much water. Want 'a cross. No cross. Quick starve. Quick freeze. No good that one.'

"He say, that one, 'Tide-crack Spirit all a time lift ice, push ice, this way, that way. Want 'a kill man. No can do.'

"He say, that one, 'Great dead whale spirit want 'a lift ice, want 'a throw ice, this way, that way, all way. Want 'a kill man. Man no go Cape Prince Wales.'

"He say, that one, 'Want 'a go Cape Prince Wales, mebbly two month, mebbly three month. Mebbly can do. Can't tell.' He say, that one."

The college-boy smiled a grim smile and pocketed his gold.

"Which all means," he said, "that the ice is not sufficiently compact, not well enough frozen together for the old boy to risk a passage, and that we 'll be obliged to wait until he thinks it 's O. K. Probably two or three months. Meanwhile, welcome to our village! Make yourselves at home!" He threw back his shoulders and laughed a boyish laugh.

"Oh!" exclaimed Marion, ready to indulge in a childish bit of weeping.

"Yes," smiled the boy, "but think of the sketches you 'll have time to make."

"No canvas," she groaned.

"That 's easy. Use squares of this seal-skin the women tan white for making slippers."

"The very thing!" exclaimed Marion. She was away at once in search of some of this new style canvas, quite forgetting the peril of natives, the danger of the food-supply giving out, the probability of an unpleasant meeting with the bearded stranger, in her eagerness to be at work on some winter sketches of these most interesting people.

In a land so little known as this, one does not seek long for opportunities to express strange and unusual things. Marion had not been established a week with Lucile in an igloo, generously provided by the chief of the village, before an unusual opportunity presented itself.

The young college fellow, whom they had come to call "Phi," in lieu of a better name, had hired three natives with dog-teams. With these he had freighted all available supplies from the wreck to the village. Among these supplies was found a well-equipped medicine-chest. During her long visits in out-of-the-way places, Marion had learned much of the art of administering simple remedies. She had not been in the village three days before her fame as a doctor became known to all the people.

She had learned, with a feeling of great relief, that the bearded stranger, who had posed as a witch-doctor, had gone away from the village. Whether he had gone toward Whaling, or south to some other village, no one appeared to know. Now that he had departed, it seemed obvious that she was destined to become the village practitioner.

It was during one of her morning "clinics," as she playfully called them, that a native of strange dress brought his little girl to her for treatment. The ailment seemed but a simple cold. Marion prescribed cough medicine and quinine, then called for the next patient. Patients were few that morning. She soon found herself wandering up the single street of the village. There she encountered the strange native and his child.

"Who are they?" she asked of a boy who understood English.

"Reindeer Chukches."

"Reindeer Chukches?" she exclaimed excitedly. "Where do they live?"

"Oh, mebbly fifteen miles from here."

"Are there many Reindeer Chukches?"

"Not now. Many, one time. Now very few. Not many reindeer. Too not much moss. Plenty starve. Plenty die."

"Ask the Chukche," Marion said eagerly, "if I may go home with him to see his people."

The boyspoke for a moment with the grave-visaged stranger.

"He say, that one, he say, 'Yes,'" smiled the boy.

"Tell him I will be back quickly." Marion was away like a shot.

Tearing into their igloo, she surprised Lucile into a score of activities. The medicine-chest was filled and closed, paints stowed in their box, garments packed, sleeping-bags rolled up. Then they were away.

Ere she knew it, Lucile was tucked in behind a fleet-footed reindeer, speeding over the low hills.

"Now, please tell me where we are going?" she smiled at Marion, who sat before her.

"We are going to visit the most unique people in all the world—the Reindeer Chukches. They are almost an extinct race now, but the time was when every clump of willows that lined the banks of the rivers of the very Far North in Siberia hid one of their igloos, and every hill and tundra fed one of their herds. And I am to paint them. Think of it! a new type of native!"

"Yes, but," Lucile smiled doubtfully, "supposing the ice gets solid while we 're gone. Suppose Phi takes a fancy to cross without us? What then?"

Marion's face sobered for a moment. But the zeal of a born artist and explorer was upon her. "Oh, fudge!" she exclaimed; "it won't. He won't. I—I—why, I 'll hurry. We 'll be back at East Cape in no time at all."



# THE WORLD'S LARGEST SHIP

By FLOYD L. DARROW

LARGER than any battle-ship of the world's proudest navy, of greater tonnage than any liner plying the ocean's highways, luxurious beyond description, the latest floating palace, now nearly completed for one of the great English steamship companies, is rightly named the *Majestic*.

The *Majestic* has a displacement of 56,000 tons. This is 10,000 tons larger than the

twelve-story building. When the lookout in the topmost crow's-nest climbs into his place—by means of a ladder inside the mast—he will be 180 feet above the water, in the loftiest lookout perch ever carried on a steamship. The rudder of this princess of the sea weighs 140 tons and is hung on a single pin weighing two tons.

The *Majestic's* power-plant is the largest

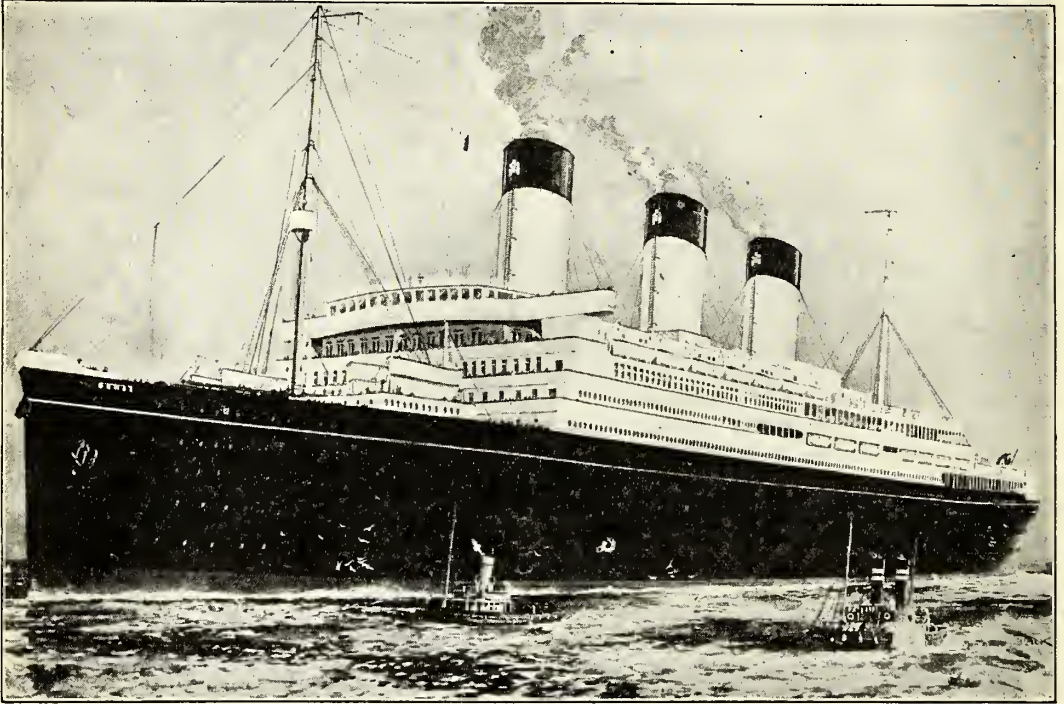

THE "MAJESTIC"—THE FIFTY-SIX-THOUSAND-TON ATLANTIC LINER

*Olympic*, 2000 tons larger than the *Leviathan*, and nearly as great as that of all the 132 ships that formed the famous Spanish Armada, sent against England in 1588. Her length is 956 feet, breadth 100 feet, and depth from boat-deck to keel 140 feet. Stood on end, she would rise 164 feet above the Woolworth Building and nearly reach the top of the Eiffel Tower. Four times around her promenade-deck is a mile. Two New York subway trains could pass abreast through each of her three smoke-stacks, which are 30 feet in diameter. The tops of these stacks stand 184 feet above the keel of the ship, or a total height equal to that of an ordinary

ever fitted in a passenger vessel. There are four huge turbine engines for driving the ship forward, and four reversing turbines. A single turbine weighs 375 tons, and the four driving-engines will develop about 100,000 horse-power, giving a speed of more than 26 miles an hour, and, in case of an emergency, 30 miles. Under her 48 boilers, oil-burners have been installed, and she will consume on a single crossing 5700 tons of liquid fuel.

The public rooms of the ship are great halls, with clear spaces and lofty ceilings, similar to those of a large city hotel. The lounge has a ceiling 26 feet high; and the

dining-room covers a floor space of more than a quarter of an acre and its ceiling is 31 feet high. Through the center of these apartments is an unbroken view 253 feet long.

The ship will have a beautiful library of 4000 volumes. There will be an elaborately fitted gymnasium, and electric and Turkish baths. A marble swimming-pool, 820 square feet in area, with capacity for 130 tons of sea-water and with thirty dressing-rooms around it, as well as a gallery for spectators, will afford pleasant pastime for the ship's guests. A playroom and nursery for the children, a tennis-court, a ball-room and winter garden, with ample provision for concerts, moving pictures, and vaudeville are other features of this ship.

The space in this great ship is equal to that of 400 average suburban residences of eight rooms each, or of 800 four-room city apartments. There are nine decks, and to make a complete tour of inspection would

require a journey of eleven miles. There will be 1245 staterooms—472 in the first cabin, 773 in the second, and third.

To care for this floating hotel and its 4100 passengers will require a crew of about 275 in the engine-room, 140 in the deck department, 550 in the steward's service, and more than 100 in the kitchens.

By means of three separate wireless stations on board, the ship will be kept in constant touch with both continents throughout an Atlantic voyage. A complete telephone system will connect all parts of the ship. The 15,000 electric lights will give a brilliancy unexcelled by the great hotels of New York, London, or Paris. Five dynamos will supply the current for these lights, as well as for the 122 motors which drive the machinery, electric fans, and elevators.

Majestic in name, construction and equipment, this mighty vessel rules the waves and for the present, the transatlantic service.

---

## THE INCA EMERALD

By SAMUEL SCOVILLE, JR.

### SYNOPSIS OF PREVIOUS INSTALMENTS

PROFESSOR AMANDUS DITSON, the great scientist, has discovered the location of Eldorado, where for hundreds of years the Incas of Peru threw the best emeralds of their kingdom into the lake as an offering. The professor's ambition in life is to secure a living specimen of the bushmaster, the largest and most venomous of South American serpents. He calls on Big Jim Donegan, the lumber-king and gem-collector, and offers to lead a party to the lake if Jim will finance the trip, and to allow the lumber-king to have the emeralds, provided Ditson can keep the bushmasters. Jim promptly agrees to this, and Jud, the old trapper, Will, and Joe, the Indian boy, who together found the Blue Pearl for Jim Donegan, agree to go on the trip. Jud and Professor Ditson bicker as to who shall lead the expedition. A whip-scorpion decides the discussion in favor of the professor. They hear and see strange and beautiful birds in the forest, and Jud gets tangled up in a multitude of thorny vines and shrubs and has an adventure with a trail-haunting black-snake. The party enjoys wild milk and honey, and Will studies the tropical butterflies. At night, in a deserted house, vampire-bats break through the screen and get into his room and he is badly frightened and bitten. The party travel by steamer to Manaus, the hottest city in the world. There they change to an Indian boat and travel down to Black River, which they enter by night, contrary to the Indian superstitions. Joe has a terrible experience with an anaconda, and Will is nearly swallowed by a giant catfish. They pass Treasure Rock and hear its story.

### CHAPTER V

#### SHIPWRECK

ABOUT the middle of the morning a distant boom sounded through the still air, which grew louder until finally it became a crashing roar. Beyond a bend in the river stretched before them a long gorge. There the stream had narrowed, and, rushing across a ledge shaped like a horseshoe, foamed and roared and beat its way among great boulders. The

paddlers brought their craft into smooth water under an overhanging bank, while they held a council of war. Professor Ditson had never been on the Rio Negros before, nor had Pinto followed it farther than Treasure Rock. For a long time the whole party studied the distant rapids carefully.

"What do you think?" whispered Will to Joe. The Indian boy, who had paddled long journeys on the rivers and seas of the far Northwest, shook his head doubtfully.



"Can do in a bark canoe," he said at last; "but in this thing—I don't know."

Pinto and Hen both feared the worst in regard to anything which had to do with Black River. It was Professor Ditson who finally made the decision.

"It would take us weeks," he said, "to cut a trail through the forests and portage this boat around. One must take some chances in life. There seems to be a channel through the very center of the horseshoe. Let's go!"

For the first time during the whole trip, old Jud looked at his rival admiringly.

"The old bird has some pep left, after all," he whispered to Will. "I want to tell you, boy," he went on, "that I've never seen worse rapids, an' if we bring this canal-boat through, it'll be more good luck than good management."

Under Professor Ditson's instructions, Pinto took the bow paddle, while Hen paddled stern with Will and Joe on one side and Jud and the professor on the other. Then all the belongings of the party were shifted so as to ballast the unwieldy craft as well as possible, and in another moment they shot out into the swift current. Faster and faster the trees and banks flashed by, like the screen of a motion picture. Not even a fleck of foam broke the glassy surface of the swirling current. With smooth, increasing speed, the river raced toward the rapids which roared and foamed ahead, while swaying wreaths of white mist, shot through with rainbow colors, floated above the welter of raging waters and the roar of the river rose to a shout. Beyond, a black horseshoe of rock stretched from one bank to the other in a half-circle, and in front of it sharp ridges and snags showed like black fangs slavered with the foam of the river's madness.

In another second the boat shot into the very grip of these jaws of death. Standing with his lithe, copper-colored body etched against the foam of the rapids, the Mundurucu held the lives of every one of the party in his slim, powerful hands. Accustomed from boyhood to the handling of the river-boats of his tribe through the most dangerous of waters, he stood that day like the leader of an orchestra, directing every movement of those behind him, with his paddle for a baton. Only a crew of the most skilled paddlers had a chance in that wild water; and such a crew was obedient to the Indian. In the stern, the vast strength of the giant negro swung the montaria into the course which the bow paddler indicated by his mo-

tions, while the other four, watching his every movement, were quick to paddle or to back on their respective sides. At times, as an unexpected rock jutted up before him in the foam, the Indian would plunge his paddle slantwise against the current and would hold the boat there for a second, until the paddlers behind could swing it, as on a fulcrum, out of danger. Once the craft was swept with tremendous force directly at an immense boulder, against which the water surged and broke. To Jud and the boys it seemed as if Pinto had suddenly lost his control of the montaria, for, instead of trying to swing out of the grip of the currents that rushed upon the rock, he steered directly at its face. The Mundurucu, however, knew his business. Even as Jud tensed his muscles for the crash, the rebound and undertow of the waters, hurled back from the face of the rock, caught the boat and whirled it safely to one side of the boulder. In and out among reefs and fangs of rock the Mundurucu threaded the boat so deftly, and so well did his crew behind him respond, that in all that tumult of dashing waves the heavy craft shipped no water outside of the flying spray.

In another minute they were clear of the outlying reefs and ledges and speeding for the single opening in the black jaw of rock that lay ahead of them. Here it was that, through no fault of their steersman, the great mishap of the day overtook them. Just beyond the gap in the rock was a little fall, not five feet high, hidden by the spray. As Pinto passed through the narrow opening he swung the bow of the boat diagonally so as to catch the smoother current toward the right-hand bank of the river, which at this point jutted far out into the rapids. As he swerved, the long montaria shot through the air over the fall. The Indian tried to straighten his course, but it was too late. In an instant the boat had struck at an angle the rushing water beyond, with a force that nearly drove it below the surface. Before it could right itself, the rush of the current from behind struck it broadside, and in another second the montaria, half-filled with the water which it had shipped, capsized, and its crew were struggling in the current.

It was Hen Pine who reached the river first. When he saw that the boat was certain to upset he realized that his only chance for life was to reach smooth water. Even while the montaria was still in mid-air he sprang far out toward the bank, where a

stretch of unbroken current set in toward a tiny cape, beyond which it doubled back into a chaos of tossing, foaming water where not even the strongest swimmer would have a chance for life. Hen swam with every atom of his tremendous strength, in order to reach that point before he was swept into the rapids beyond. His bare, black arms and vast shoulders, knotted and ridged with muscle, thrashed through the water with the thrust of a propeller-blade as he swam the river-crawl which he had learned from Indian swimmers. For an instant it seemed as if he would lose, for when nearly abreast of the little cape several feet of racing current still lay between him and safety. Sinking his head far under the water, he put every ounce of strength into three strokes, the last of which shot him just near enough to the bank to grip a tough liana which dangled like a rope from an overhanging tree-top. Pinto, who was next, although no mean swimmer, would never have made the full distance, yet managed to grasp one of Hen's brawny legs, which stretched far out into the current.

"You hold on," he muttered to the great negro; "we make a monkey-bridge and save them all."

Hen only nodded his head and took a double turn of the lianas around each arm. Professor Ditson was the next one to win safety, for the two boys were staying by Jud, who was a most indifferent swimmer. As the professor's long, thin legs dangled out into the current like a pair of tongs, with a desperate stroke, Will caught one of his ankles and was gripped in turn by Joe, and Jud locked both of his arms around the latter's knees, while the swift river tossed his gray hair and beard along its surface. As the full force of the current caught this human chain it stretched and sagged ominously. Then each link tightened up and prepared to hold as long as flesh and blood could stand the strain.

"Go ahead, Jud!" gasped Will, over his shoulder; "pull yourself along until you get to shore; then Joe will follow, and then I. Only hurry—the professor won't be able to hold on much longer nor Hen to stand the strain."

"Don't hurry on my account," sounded the precise voice of Professor Ditson above the roar of the waters. "I can hold on as long as any one." And as he spoke, Will felt his gaunt body stiffen until it seemed all steel and whipcord.

"Same here!" bellowed Hen, his magnificent body stretched out through the water as if on a rack. "Take your time and come along careful."

In another minute the old trapper had pulled his way hand over hand along the living bridge until he too had a grip on one of the dangling lianas. He was followed by link after link of the human chain until they were all safe at the edge of the bank. Hen was the first to scramble up and give the others a helping hand, and a moment later all six of the treasure seekers stood safe on the high ridge of the little promontory and sadly watched the boat which had borne them so well smash into a mass of floating, battered planks among the rocks and disappear down the current. Along with it went their guns, their ammunition, and their supplies. Jud alone retained the automatic revolver which he always wore, with a couple of clips holding sixteen cartridges, besides the eight in the cylinder. Hen also could not be termed weaponless, for he still wore his machete; while Will had a belt-ax, Joe a light hatchet, and Professor Ditson a sheath-knife. Besides these, the Indian had his bamboo tinder-box and flint and steel, which he always wore in his belt. These and the jack-knives and a few miscellaneous articles which they happened to have in their pockets or fastened to their belts comprised the whole equipment of the party. Before them stretched a hundred miles of uncharted jungle, infested by dangerous beasts and wandering cannibal tribes, through which they must pass to reach the old Slave Trail. Half that distance behind them was the Amazon. If once they could find their way back to that great river and camp on its banks, sooner or later a boat would go by which would take them back to Manaos. This, however, might mean weeks of delay and perhaps the abandonment of the whole trip. As they stood upon a white sand-bank far enough back from the river so that the roar of the rapids no longer deafened them, it was Pinto who spoke first.

"Master," he said to Professor Ditson, "it is no time for council. Let us have fire and food first. A man thinks more wisely with his head when his stomach is warm and full."

"I'll say the man is right," said Jud, shivering a little in his wet clothes as the coolness of approaching night began to be felt through the forest; "but where is that same fire and food goin' to come from?"



Pinto's answer was to scrape shavings from the midrib of a dry palm-leaf. When he had a little pile on the white sand in front of him, he opened the same kind of a tinder-box which our ancestors used to carry less than a

going and, followed by Will, hurried through the jungle toward the towering fronds of a peach-palm which showed above the other trees. Twisting together two or three lianas, the Indian made from them a light, strong

belt. This he slipped around himself and the tree, and, gripping it in both hands, began to walk up the rough trunk, leaning against this girdle and pushing it up with each step, until, sixty feet from the ground, he came to where the fruit of the tree was clustered at its top. It grew in a group of six, each one looking like a gigantic, rosy peach a foot in diameter. In a moment they all came whizzing to the ground, and the two staggered back to the fire with the party's supper on their backs. Stripping off the thick husk, Pinto exposed a soft kernel which, when roasted in the coals, tasted like a delicious mixture of cheese and chestnuts.

When at last all the members of the party were full-fed and dry, the wisdom of Pinto's counsel was evident. Every one was an optimist; and after all, the best advice in life comes from optimists. Even Pinto and Hen felt that now that they had lived through the third misfortune they



"IN SPITE OF THE IGUANA'S SIZE, THE COATI MADE SHORT WORK OF IT"  
(SEE PAGE 755)

century and a half ago. Taking out from this an old file and a bit of black flint, with a quick glancing blow he sent half a dozen sparks against a dry strip of a feltlike substance found only in the nests of certain kinds of ants. In a minute a deep glow showed from the end of this tinder, and placing it under the pile of shavings, Pinto blew until the whole heap was in a light blaze. Hastily piling dry wood on top of this, he left to the others the task of keeping the fire

need expect no further ill-luck from the river.

"Forward or back—which!" was the way Professor Ditson put the question.

"Forward!" voted Will.

"Forward!" grunted Joe.

Jud seemed less positive.

"I sure would hate to go back," he said, "after old Jim Donegan had grub-staked us, an' tell the old man that, while we 're good pearlers, we 're a total loss when it comes to

emeralds. Yet," he went on judicially, "there 's a hundred miles of unexplored forests between us and the professor's Trail, if there is any such thing. We 've lost our guns; we 've no provisions; we 're likely to run across bands of roving cannibals; lastly, it may take us months to cut our way through this jungle. Therefore I vote—forward!"

"That 's the stuff, Jud," exclaimed Will, much relieved.

"Oh, I don't believe in takin' any chances," returned the old man, who had never done anything else all his life. "My idea is to always look at the dangers—an' then go ahead."

"What about me?" objected Hen. "I ain't a-goin' to cut no hundred miles of trail through this here jungle for nobody."

The answer came, sudden and unexpected, from the forests.

"John cut wood! John cut wood! John cut wood!" called some one, clearly. It was only a spotted goatsucker, a bird belonging to the same family as our northern whip-poor-will, but Hen was much amused.

"You hear what the bird say, you John Pinto. Get busy and cut wood," he laughed, slapping his friend mightily on the back.

"All right," said the Indian, smiling, "John will cut wood. Master," he said to Professor Ditson, "if all will help, I can make a montaria in less than a week, better than the one we lost. Then we not have to cut our way through jungle."

"Pinto," said Professor Ditson, solemnly, for once dropping into slang, "the sense of this meeting is—that you go to it."

That night they followed the bank until they found a place where it curved upward into a high, dry bluff. There on soft white sand above the mosquito-belt they slept the sleep of exhaustion. It was after midnight when Will, who was sleeping between Professor Ditson and Jud, suddenly awoke with a start. Something had sniffed at his face.

Without moving, he opened his eyes and looked directly into a pair that flamed green through the darkness. In the half-light of the setting moon he saw, standing almost over him, a heavily built animal as big as a small lion. Yet the short, upcurved tail and the rosettes of black against the gold of his skin showed the visitor to be none other than that terror of the jungle, the great jaguar, which in pioneer days used to come as far north as Arkansas and is infinitely more to be feared than the panthers which our forefathers dreaded so. This one had none of

the lithe grace of the cougars which Will had met during the quest of the Blue Pearl, but gave him the same impression of stern, tremendous strength and girth that a lion possesses.

All of these details came to Will the next day. At that moment, as he saw the great round head of this king of the South American forest within a foot of his own, he was probably the worst-scared boy on the South American continent. Will knew that a jaguar was able to drag a full-grown ox over a mile, and that this one could seize him by the throat, flirt his body over one shoulder, and disappear in the jungle almost before he could cry out. The great beast seemed, however, to be only mildly interested in him. Probably he had fed earlier in the evening.

Even as Will stared aghast into the gleaming eyes of the great cat, he saw, out of the corner of his eye, Jud's right hand stealing toward his left shoulder. The old trapper, as usual, was wide awake when any danger threatened. Before, however, he had time to reach his automatic, Professor Ditson, equally watchful from his side, suddenly clapped his hands together sharply, close to the jaguar's pricked-up ears. The effect was instantaneous. With a growl of alarm, the great beast sprang backward and disappeared like a shadow into the forest. The professor sat up.

"That 's the way to handle jaguars," he remarked. "He 'll not come back. If you had shot him," he continued severely to Jud, who held his cocked revolver in one hand, "he would have killed the boy and both of us before he died himself." And the professor lay down again to resume his interrupted slumbers.

It was this occurrence which started a discussion the next morning in regard to weapons, offensive and defensive.

"I 'low," said Hen Pine, making his heavy machete sing through the air as he whirled it around his head, "that I can stop anything I meet with this 'ere toothpick of mine."

"Hen," remarked Jud, impressively, "do you see that round thing hangin' against the sky in the big tree about fifty yards away?"

"Yessah, yessah," responded Hen, "that 's a monkey-pot full of Brazil-nuts."

"Well, boy," returned the old trapper, "just keep your eye on it."

As he spoke he raised his automatic to the level of his hip, shooting without sighting, with that strange sixth sense of position which some of the great revolver-shots of a



past generation used to acquire. There was a flash, a sharp spat, and the case of nuts about twice the size of a man's fist came whizzing to the ground. Hen stared at the old trapper with his mouth open.

"You is sure the hittenest shooter ever I see," he said at last.

Joe said nothing, but, drawing from his belt the keen little hatchet which he always carried, poised himself with his left foot forward, and, whirling the little weapon over his head, sent it hurtling through the air toward the same Brazil-nut tree. The little ax buzzed like a bee and, describing a high curve, buried itself clear to the head in the soft bark. Picking up a couple of heavy round stones, Will put himself into a pitching position and sent one whizzing in a low straight peg which hardly rose at all and which struck the tree close to Joe's hatchet with a smack which would have meant a broken bone for any man or beast which it struck, for, as Joe had found out when the two were pursued by Scar Dawson's gang, Will was a natural born stone-thrower, with deadly speed and accuracy. It was Professor Ditson, however, who gave what was perhaps the most spectacular exhibition of all. Standing before them, lean and gaunt, he suddenly reached to his belt and drew out a keen, bone-handled, double-edged sheath-knife. Poising this flat on the palm of his hand, he threw it, with a quick jerk, with much the motion of a cricket-bowler. The keen weapon hissed through the air like an arrow, and was found sunk nearly to the hilt in the bark between the mark of Will's stone and the head of Joe's hatchet.

"When I was a very young man," the professor explained, embarrassed, "I attained a certain amount of proficiency with the bowie-knife."

"I 'll say you did!" exclaimed Jud, as he worked the knife out of the tough bark. "Any cannibal that comes within fifty yards of this party is liable to be chopped an' stabbed an' broken an' shot—to say nothin' of Hen's machete at close quarters."

Pinto had watched these various performances in silence.

"This evening," he said at last, "I show you a gun that kills without any noise."

Borrowing Joe's hatchet, he disappeared into the woods, to come back half an hour later with a nine-foot stick of some hard, hollow, light wood about an inch in diameter, straight as an arrow and with a center of soft pith. Laying this down on a hard

stump, Pinto, with the utmost care, split the whole length into halves. Then, fumbling in his belt, he pulled from it one of the sharp teeth of the paca, that curious reddish rodent which is half-way in size and appearance between a hog and a hare and which is equally at home on land and in water and whose two-inch cutting-teeth are among the favorite ready-made tools of all South American Indians. With one of these Pinto carefully hollowed out each section of the stick, smoothing and polishing the concave surface until it was like glass. Then, fitting the two halves together, he wound them spirally with a long strip of tape which he made from the tough, supple wood of a climbing palm, waxed with the black wax of the stingless bees. When it was finished he had a light, hollow tube about nine feet long. At one end, which he tapered slightly, he fixed, upright, the tiny tooth of a mouse, which he pressed down until only a fleck of shining ivory showed as a sight above the black surface of the tube. At the other end he fitted in a cup-shaped mouthpiece, chiseled out of a bit of light, seasoned wood.

By noon it was finished, and Jud and the boys saw for the first time the deadly blow-gun of the Mundurucu Indians. For arrows, Pinto cut tiny strips from the flinty leaf-stalks of palm-leaves. These he scraped until the end of each was as sharp as a needle. Then he feathered them with little oval masses of silk from the seed-vessels of silk-cotton trees, whose silk is much fluffier and only about half the weight of ordinary cotton. In a short time he had made a couple of dozen of these arrows, each one of which fitted exactly to the bore of the blow-gun, and also fashioned for himself a quiver of plaited grasses, which he wore suspended from his shoulder with a strip of the palm tape.

Late in the afternoon he made another trip into the forest, returning with a mass of bark scraped from a tree called by the Indians "mavacure," but which the white settlers in South America have named the poison-tree. This bark he wet in the river, and then pounded it between two stones into a mass of yellowish fibers, which he placed in a funnel made of a plantain-leaf. Under this he set one of the aluminum cups, which each of the party carried fastened to his belt. This done, he poured in cold water and let the mass drip until the cup was full of a yellow liquid which he heated over a slow fire. When it thickened he poured in some

of the milky juice of another near-by tree, which turned the mixture black. When it had boiled down to a thick, gummy mass Pinto wrapped it up carefully in a palm-leaf,

left arm, as a white man would hold a gun. Even as he raised the long tube, there came a crashing through the near-by trees, and the party looked up to see a strange sight.

Rushing along the branches came a pale, greenish-gray lizard, marked on the sides with black bars and fully six feet in length. Along its back ran a crest of erect spines. Even as its long, compressed tail whisked through the foliage, a reddish animal, which resembled a lanky raccoon, sprang after it like a squirrel, following hard on its trail.

"It's an ol' coati chasin' a big iguana," muttered Hen, as the pair went by. "They're both mighty fine eatin'."

At first, the pursued and the pursuer seemed equally matched in speed. Little by little, the rapid bounds of the mammal overtook the swift glides of the reptile, and in a tree-top some fifty yards away the iguana turned at bay. In spite of its size and the threatening, horrible appearance of its uplifted spines, the coati made short work of it, worrying it like a dog, and finally breaking its spine. Even as its long bulk hung lifeless from the powerful jaws of the animal, Pinto drew a deep breath and, sighting his long tube steadily towards the distant animal, drove his breath through the mouth-piece with all his force. There followed a startling pop, and a white speck flashed through the air toward the coati. A second later, the latter, still holding the dead iguana, gave a spring, as if struck by something, and

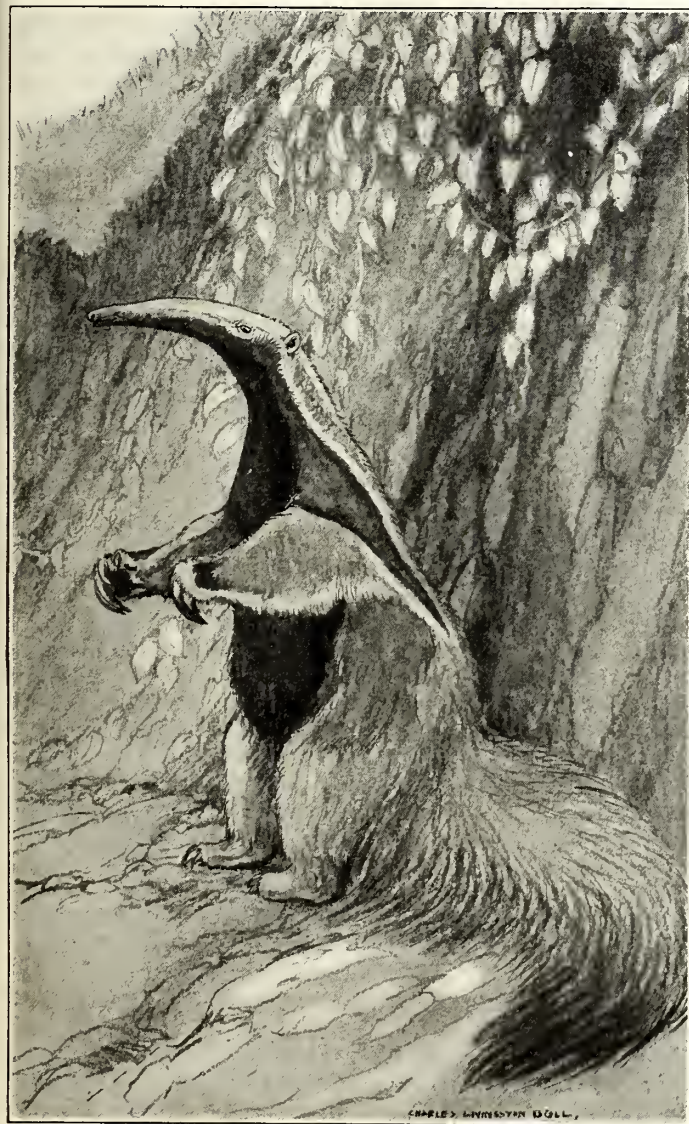

"THE GREAT BEAST WAS SOON BROUGHT TO BAY" (SEE NEXT PAGE)

after first dipping every one of his arrows into the black compound.

So ended the making of the famous urari arrow-poison, which few white men indeed have ever seen brewed. When it was safely put away, Pinto carefully fitted one of the tiny arrows into the mouthpiece and raised the blow-gun to his mouth, holding it with both hands touching each other just beyond the mouthpiece, instead of extending his

started off again through the tree-tops, the great body of the dead lizard trailing behind. Suddenly, the coati began to go slower and slower and then stopped short. Its head drooped. First one paw and then another relaxed, until, with a thud, the coati and iguana struck the ground together, both stone-dead. The boys rushed over and found Pinto's tiny, deadly arrow embedded deep in the coati's side. Less than



a minute had passed since it had been struck, but the deadly urari had done its work. Fortunately, this poison does not impair the food value of game, and later on, over a bed of coals, Hen made good his words about their eating qualities. The coati tasted like roast possum, while the flesh of the great lizard was as white and tender as chicken.

"I feel as if I was eatin' a dragon," grumbled Jud, coming back for a third helping.

There followed a week of hard work for all. Under Pinto's directions, taking turns with Jud's ax, they cut down a yellow stonewood tree, which was almost as hard and heavy as its name. Out of the trunk they shaped a log some nineteen feet in length and three feet through which, with infinite pains, and with lianas for ropes, they dragged on rollers to the water's edge. Then, with enormous labor, working by shifts with Joe's hatchet, Jud's ax, and Hen's machete, they managed to hollow out the great log. At the end of the fourth day, Jud struck.

"I 'll work as hard as any man," he said, "but I got to have meat. If I work much longer on palm-nuts, I 'm liable to go plumb nutty myself."

As the rest of the party felt the same craving, Pinto and Jud were told off to hunt for the rest of that day. It was Jud who first came across game, a scant half-mile from camp, meeting there an animal which is one of the strangest still left on earth and which, along with the duck-bill of Australia and the great armadillo, really belongs to a past age, before man came to earth, but by some strange accident has survived to this day.

In front of him, digging in a dry bank with enormous, curved claws was an animal over six feet in length and about two feet in

height. It had great hairy legs, and a tremendous bushy tail, like a vast plume, curled over its back. Its head ended in a long, tapering, toothless snout, from which was thrust constantly a wormlike, flickering tongue, while a broad oblique stripe, half gray and half black, showed on either side.

"There ain't no such animal," murmured Jud to himself, examining the stranger with awe.

Pinto's face shone with pleasure when he came up.

"It giant ant-eater and very good to eat," he remarked cheerfully.

Upon seeing them, the great beast shuffled away, but was soon brought to bay, when it stood with its back against the bank, swinging its long snout back and forth and making a little whining noise. Jud was about to step in and kill it with a blow from his ax, but Pinto held him back.

"No get in close to ant-bear," he warned, pointing to the giant's claws. "He rip you to pieces. You watch."

Stepping back, the Indian raised his blow-gun to his mouth. Again came the fatal pop, and the next second one of the tiny arrows was embedded like a thorn in the side of the monster's snout. For a moment the great ant-eater tried to dislodge the tiny, pointed shaft with his enormous claws. Then he stopped, stood motionless for a moment, swayed from side to side, and sank dead without a sound or struggle. With the help of Jud's ax and his own knife, the Indian soon quartered and dressed the great beast, and an hour later the two staggered back to camp loaded down with a supply of meat which, when roasted, tasted much like tender pork.

"Now," said Jud, smacking his lips after a full meal, "bring on your work!"

*(To be continued)*

## HOW HE KNEW

FATHER'S watch says half-past six;  
 Mother's does not go.  
 The parlor clock is always fast,  
 The kitchen clock too slow.

My watch is being mended,  
 Jimmy's has no spring.  
 Sister's, on her bracelet,  
 Is just a gimcrack thing.

I did n't hear the whistles blow,  
 And don't know what is right,  
 But think it must be dinner-time  
 Just by my appetite!

T. J.

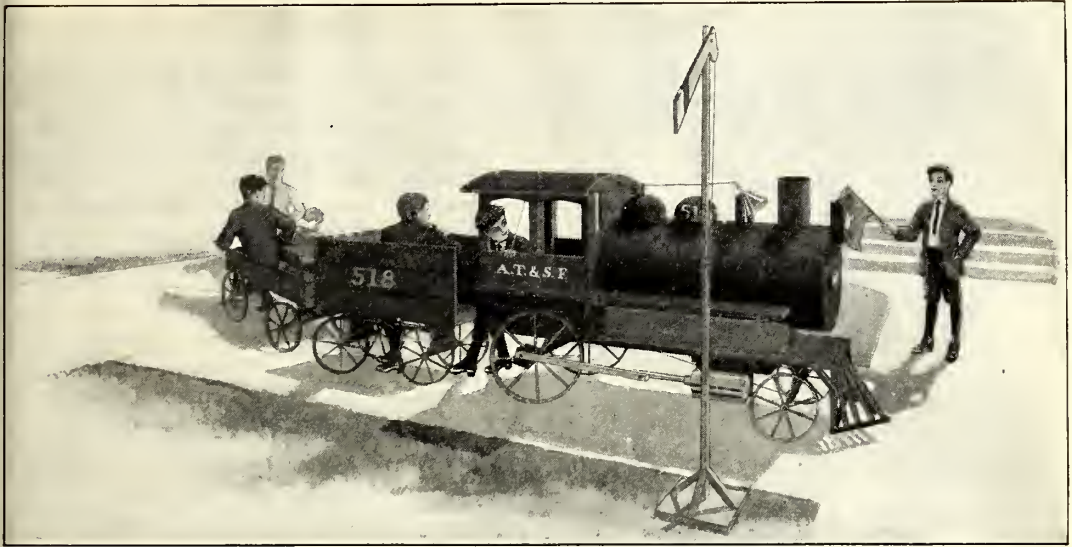

THE HOME-MADE RAILWAY IN OPERATION

## A BOY'S LOCOMOTIVE WAGON

By A. NEELY HALL

*Author of "The Boy Craftsman," "Carpentry and Mechanics for Boys," etc.*

WITH a home-made locomotive wagon like that shown in the illustrations, you and your friends can operate a sidewalk railway, attaching behind it a wagon with high broad sides for a tender, and coupling together express-wagons, pedal-wagons, and velocipedes for passenger-coaches.

Old velocipede, tricycle, wagon, or baby-carriage wheels may be used for the locomotive wagon, and if you have n't what you need, you ought to be able to buy wheels from other boys. The diameter of the front wheels should be ten or twelve inches, and that of the rear wheels, about eighteen inches.

Make the wagon-bed (Fig. 1 A) eighteen inches wide and five feet nine inches long, battening the boards together on the under side, and saw the wooden axles B and D, also piece C, out of two-inch plank (Figs. 2 and 3) of the proper width to bring the wagon-bed fifteen inches above the ground when mounted upon the wheels. B and D should be grooved along the bottom (Fig. 4) for the axle-rods to set in; B and C should have a five-eighth-inch hole bored through their centers for the king-bolt to slip through; and B should be cut on the bottom to admit the nut (Fig. 2). Spike C and D to the under side of the wagon-bed—C six

inches from the front, and D twelve inches from the back. Use a five-eighth-inch bolt, nine inches long, for a king-bolt with which to pivot B to C. Make a strap-brace for the front axle from a piece of hoop-iron. Bend it as shown in Figure 5, and punch a hole near each end; slip the lower end of the strap over the king-bolt, and screw the other end to the wagon-bed (Figs. 2 and 5). As an additional axle-brace, fasten a reach between C and D (Figs. 2, 3, and 5). The axle-rods should be twenty-two inches long, threaded on the ends, and provided with nuts and washers; they should have quarter-inch holes drilled through them three inches from each end, through which to bolt them to the wooden axles (Figs. 2 and 3).

The wagon-body (Fig. 1) is made out of six-inch boards. Cut pieces E twenty-four inches long, F twenty inches long, pieces G three feet long, and H six inches long. Nail these pieces together in the positions shown; then cut strips, I, two inches wide by twenty-four inches long, and nail them in place with their inside edges flush with boards E (Fig. 1).

Make the sides of the engine-cab as shown in Figure 7, battening the boards together with strips a, b, and c, and cutting board d so as to form arched tops to the windows.



Nail the sides to the edges of strips I (Fig. 1), then cut the front boards and nail them to the sides. Cut two narrow openings in the front for windows and fasten an arched piece at the roof line (J, Fig. 6). The curve

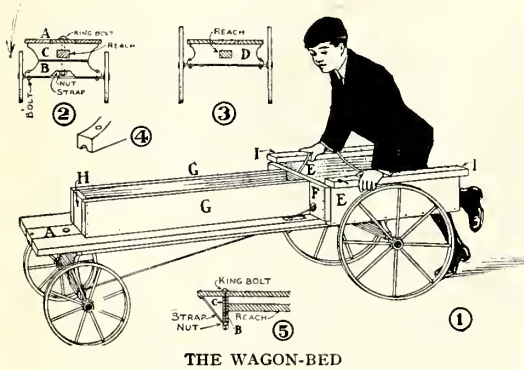

of the cab roof is formed with pieces of barrel-hoop fastened to horizontal strips nailed along the tops of the sides (K, Fig. 6); bend them to the curve of board J.

Get five barrel-hoops eighteen inches in diameter for the boiler framework, and fasten them to boards G ten inches on centers (L, Fig. 6). Cut strips O and strips P three feet six inches long and nail them to hoops L; fasten hoop M to their ends, and nail a piece of a hoop to strips O at N. Fasten strips O in hoop M and crosspieces Q to strips O (Fig. 6).

Procure two old derby hats for the steam-dome and sand-box (S and T, Fig. 6), and tack them to a board nailed to strips P. Hunt up a section of six-inch stovepipe for the smoke-stack (U, Fig. 6), cut a six-inch hole in a board for it to fit in, and nail the board to strips P.

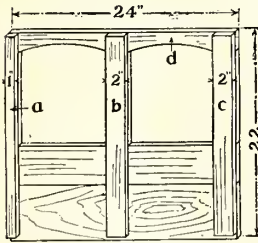

HOW TO MAKE THE SIDES OF THE ENGINE-CAB

Figures 8 and 9 show the details of the bell, which consists of a tin funnel (a, Fig. 8) mounted between two uprights (b, Fig. 9) and punch holes in the funnel for it to run through; then, for a tongue, suspend a piece of iron (c, Fig. 9) from the center of the axis, and drive a peg (d) with a screw-eye in the end in the funnel spout, to which to tie the bell-cord. Fasten the ends of the axis to uprights V with small staples, and bore a hole in the front

of the engine-cab for the bell-cord to run through.

Figure 6 shows how the cow-catcher, or pilot, is built up of wooden strips and fastened to the front of the wagon-bed.

Details for the making of the piston-rods, cylinders, and connections are shown in Figures 10 to 14. The cylinders are each made out of two tomato-cans (a and b, Fig. 10), a twelve-inch piece of cardboard mailing-tube about an inch and a half in diameter (e, Fig. 11), and two circular blocks of wood (c and d, Fig. 10). Remove both ends of can a and one end of can b. Cut blocks c and d to fit the cans, bore the center holes large enough for the mailing-tube to slide through, and assemble the parts as shown in Figure 11, tacking the cans to the blocks. The piston-rods (Fig. 12) are pieces of broom-handles fourteen inches long, and the connecting-rods (Fig. 13) are inch-and-a-half strips of wood thirty inches long. Cut the spoke-blocks (f and g, Fig. 14) about two and one half by three inches, and bolt them

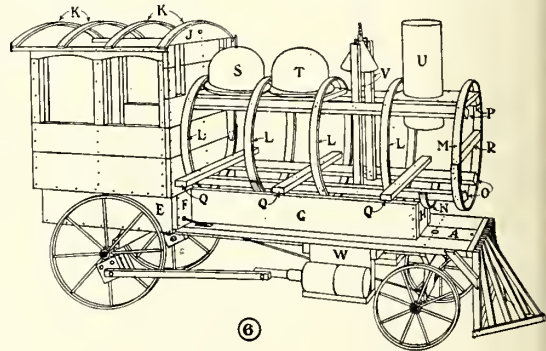

THE LOCOMOTIVE IN DETAIL

to the wheels close to the hubs, using two bolts and countersinking their heads, as shown. Bolt the piston-rods to the connecting-rods and the connecting-rods to the spoke-blocks. Make the brackets (W, Figs. 6 and 11) to support the cylinders, and hang them from the wagon-bed in the proper position to bring the center of the cylinders on a line with the hubs of the rear wheels.

Canvas or heavy muslin should be used for the boiler-jacket and for covering the cab roof. Stretch the material as evenly as possible and tack it in place with large-headed tacks. Then cut and fit the running-boards to the crosspieces Q and the cab sides.

The engine headlight may be made from a gallon syrup- or varnish-can, as shown in Figures 15 and 16. With a can-opener, cut a large round hole in the front, a smaller hole

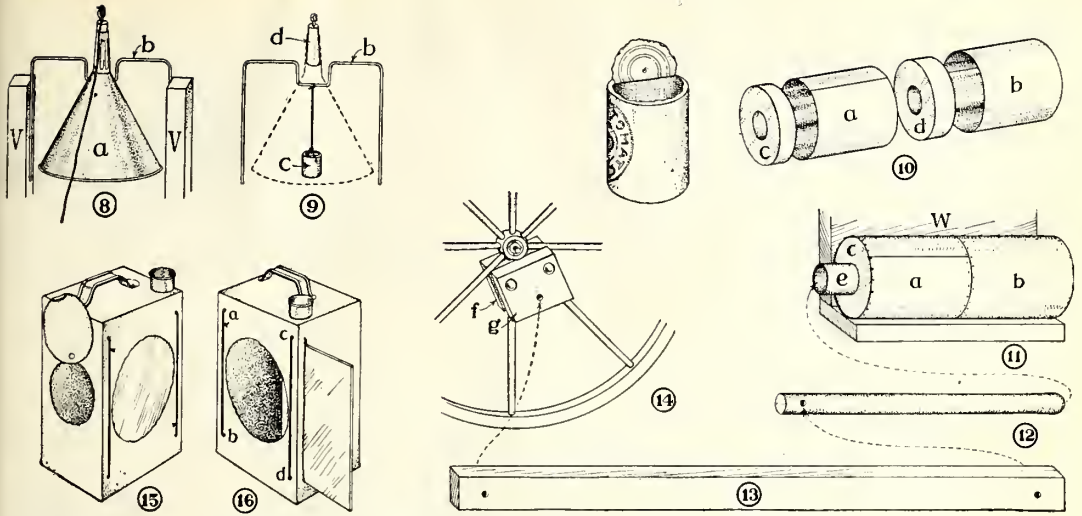

HOW TO MAKE THE BELL, HEADLIGHT, CYLINDERS, AND PISTONS

in one side, and a long slit in the other side. Slip a piece of glass through the slit in the side of the can (Fig. 16) and wire it in place, running wires through holes a, b, c, and d, and twisting their ends as shown. Make a tin slide to cover the hole in the side of the can, and pivot it in place with a brass fastener (Fig. 15). The candle, which is fastened to the bottom of the can, is lighted through this opening.

Paint the locomotive wagon black, letter the number on the sand-box and boiler front, and the name of the road on the side of the cab.

The locomotive is pushed by the boy in the cab, and is steered by means of a rope attached near the ends of the front axle and run through slots cut in the wagon-bed and then through holes bored in the front of the cab (Fig. 6).



When something shot athwart  
the sky  
As rosy light began to wane,  
Our Billy cried "A dragon-fly!"  
The fairies cried "An aëroplane!"



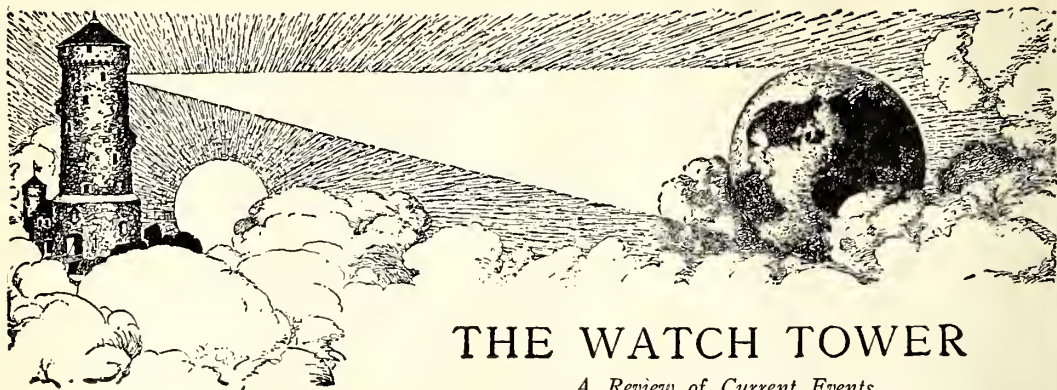

## THE WATCH TOWER

*A Review of Current Events*

By EDWARD N. TEALL

### OUR "WATCH ON THE RHINE"

SOME excitement was caused when Secretary Hughes, through the American member of the Reparations Committee, requested that \$240,000,000 be set aside to pay for the maintenance of the American Army of Occupation. England was surprised, France was vexed.

We can imagine the French and English members of the commission saying something like this: "What are our American friends up to? They won't meet us at Genoa, yet here they are trying to tell us what to do with the reparation money! They did not sign the Versailles Treaty; they made a separate peace. Well, let them make a separate collection!"

The Allies are inclined to think they hold a first mortgage on Germany, and the United States a second mortgage. That is to say, they think Germany should pay their bill first, and then ours. The American message to the Reparations Commission, Mr. Hughes explained later, was meant merely to notify

the Allies that we considered our claim equal to theirs, and that German payments should be divided in proportion to the total debt to all Germany's creditors.

Germany, of course, was amused and pleased by the incident. Not, perhaps that she would really like to see America, England, and France quarreling over the money, but that America seemed to her to be working on her side. She would rather have each million marks divided between the two bills than to have to handle them separately.

Here, as in other matters, we were acting according to the old American tradition of independence and fair play all round.

### THE FOUR-POWER TREATIES

SENATOR REED said something like this, in a debate on the treaties: "We refused to take the medicine when a Democratic President held the spoon. Why should we take the same medicine when a Republican President



Wide World Photos

A REVIEW OF AMERICAN TROOPS IN GERMANY

holds the spoon?" This expressed in homely fashion the view held by some senators that the treaties of the Washington conference would commit us to a Pacific alliance just as much as the Treaty of Versailles, including the League of Nations covenant, would have committed us to a European alliance.

how much was sincere opposition to the "entangling alliance" idea. It seemed odd for President Harding's administration, blamed by Europe for not coöperating more fully with European Governments, to be accused, here at home, of endeavoring to form an alliance with them. And it was not



© Underwood & Underwood

ST. GEORGE'S PALACE, GENOA, WHERE THE CONFERENCE WILL BE HELD

Now, the treaties were drawn so as to do this one great thing, principally: to enable England and Japan to cancel their treaty on affairs in the Pacific. We wanted that treaty canceled, because we feared it might possibly force us to war with England.

The four-power treaty made it possible to substitute for that Anglo-Japanese alliance an agreement whereby England, France, Japan, and the United States would all be pledged, in case of disagreement between any two of them, to get together and talk things over before taking any warlike steps. It made each combination of three a guardian over the behavior of the fourth.

It was not easy, through the long debate, to tell how much of the battle was merely partisan, Republicans vs. Democrats, and

easy to be sure whether Democratic senators were patriotic or partisan.

During the long and bitter debate, there were many of us who felt that it would be a mistake, a terrible mistake, for the United States, after calling the conference, to repudiate its works.

#### GENOA? "THANK YOU—NO," SAYS UNCLE SAM

A DIPLOMATIC document of great importance and rare interest was Secretary Hughes's note to Ambassador Ricci of Italy, requesting him to inform his Government that the United States could not take part in the economic conference at Genoa. The reason for rejection of the invitation was that the



United States Government felt that the original project for a discussion of ways and means to revive international commerce had been displaced by a program having more to do with political relations.

England, at first shocked by the refusal to send a delegation, quickly recognized the fairness of our contention, and admitted that the note was based on the traditional American policy of not taking part in the political relations of European countries with one another.

France was not quite so ready to give us credit for good sense and fair dealing. She was anxious to have the matter of reparation payments by Germany included in the Genoa program. On the economic side, she put emphasis on the debts of the Allies to us, and thought we ought to help devise a plan to help Europe pay. We do not think this is a fair view of our Government's motive. We do *not* put those debts ahead of everything else!

Germany was pleased, for she thought the decision showed desire by the United States to influence the European Governments in a way that would make it easier for Germany. She, too, was wrong in thinking our decision based on particular interests.



Underwood & Underwood

TEXTILE WORKERS ON STRIKE IN THE PAWTUXET VALLEY, RHODE ISLAND

The decision expressed the good old American policy of not "butting in" on other folks' affairs. Mr. Hughes clearly pointed out that when the other Governments were ready to talk about business, instead of politics, Uncle Sam would be with them.

## HOURS AND WAGES IN THE NEW ENGLAND COTTON-MILLS

THE textile industry in New England shared with other industries, this spring, the discomforts of deflation—that is, of the return to normal conditions in prices of goods and wages of workers. The mill-owners announced a cut in wages, and the workers went on strike.

The manufacturers declared they could not get business unless they sold their goods at lower prices, and that they could not make the mills pay unless the amount given out in wages was decreased. They also asserted that the cut was not equal to the advances given in the war years. If that is true, it must be true that the earnings of the mill-workers represent a better standard of living than that which the workers had before the war.

But the strikers refused to accept that argument. It is to be feared that a radical foreign element was responsible for some of the trouble. The Rhode Island Board of Conciliation and Mediation tried to get the employers and the strikers to meet and talk it out, but neither side would give in. The owners declared they would rather not operate at all than to yield, and the strike managers said they would see it through to a finish. And so the fires went out, the machinery stood idle, production ceased.

Now, the question of wages could surely be settled without such a crippling of the industry. What the owners can afford to pay, and still make a fair profit, is a matter of figures. But another matter came in to complicate the situation: an attempt to go back to the old 54-hour week, nine hours a day for six days.

Right here the sympathy of THE WATCH

TOWER for the mill-owners comes to an end. The 48-hour week is an American institution. Eight hours a day is as much as an American mill-worker ought to be required to work, as his contribution to the business. After eight hours, the worker's efficiency lessens. Tired

## NATURE AND SCIENCE FOR YOUNG FOLK

### A COMPACT WIRELESS RECEIVING APPARATUS INVENTED BY A TWELVE-YEAR-OLD BOY

ONE day, several weeks ago, I met by appointment at the American Museum of Natural History in New York City three boys whom I had invited to have lunch with me there in the quaint basement restaurant, which is an exact replica of a portion of an ancient Aztec temple in Mexico. The guest of honor was Kenneth R. Hinman, of Plainfield, New Jersey, a youthful inventor, who has devised an ingenious wireless receiving-set which has attracted a great deal of attention, both in scientific circles and among the general public. This set is of such a size and shape that it can be as readily carried in one's vest pocket, or even in a good-sized pocketbook, as if it were an ordinary safety-match box; yet it is possible to pick up messages with it from a distance of thirty miles or more. The other two boys were Kenneth's brother, Irving Hinman, and his cousin, Gordon Bond—the latter a son, by the way, as ST. NICHOLAS readers will be interested to learn, of Mr. A. Russell Bond, whose stories and articles have so long delighted them.

All of the boys are enthusiastic Boy Scouts, and they are keenly interested in the possibilities this deftly constructed apparatus obviously affords for keeping in touch with their homes when off on long hikes, picnics, or camping expeditions. Among the things that especially attracted them in the museum were the specimens of galena and silicon, which are among its treasures, since these minerals are frequently employed as detectors in wireless apparatus.

One of the striking features of the apparatus is its simplicity and the every-day character of the materials employed in it. For instance, the ground connection and the aerial are each composed of ordinary small wire ending in a letter-clip and insulated by means of rubber tubing just large enough to be slipped over the wire.

Kenneth is now thirteen years old, but he was only twelve when his invention was made. He happened to see a prize offered for such a device, and at once set his wits to work to try to win it. While he did not finish it in time to enter the competition which inspired

it, he has since won with it a prize of a silver cup offered in another contest. I asked him to give me an account of it in his own words for the readers of ST. NICHOLAS, and this is what he has to say:

"The set is not necessarily, as it is thought,



© Underwood & Underwood

THE YOUNG INVENTOR AND HIS BROTHER USING THE RECEIVING APPARATUS ON A WINTER HIKE

the size of a match-box. I do not claim it to be the smallest, although I do claim it is the *most compact wireless set, so far invented, in the world.* The human hand can be made no smaller than it is; so why make the set smaller than could be conveniently handled or operated. If it was made littler, it would no longer be a practical, simple, and easily worked set, but a novelty of no great value. It requires no upkeep, and actually receives,



by radiophone, opera selections, concerts, weather reports, bedtime stories, etc., within a radius of about thirty miles, and radiotelegraph a much greater distance."

While Kenneth conceived and constructed his invention in a very short time,—not more than a few days, in fact,—he had previously been interested, like so many other boys, in the whole subject of radio communication and had been eager to learn all he could about it. Furthermore, he has shown great interest, so his father tells me, in mechanical objects since he was a very small child, when he used to make surprisingly clever "cut outs" from paper with a



©Underwood & Underwood

MAYOR LOIZEAU OF PLAINFIELD, NEW JERSEY, AND KENNETH HINMAN LISTENING IN ON A BROADCAST MESSAGE WITH KENNETH'S APPARATUS

pair of scissors, choosing as his subjects the various things he saw about him, such as his own little velocipede and passing automobiles.

While we can not give a complete description of the apparatus, because of reasons connected with the Patent Office, we may say that it is operated by a tuning-coil and a detector. It is the function of the detector to pick up the electric vibrations coming through the air from one or another sending-station, while the tuning-coil, as its name implies, transforms these to the proper wave-length, so that the vibrations at the receiving end may be in harmony with those at the sending end.

When the set is to be used, a ground connection is established in any convenient manner; for example, the ground wire may be hooked up to an ordinary fence of insulated wire, or the connection may be made through an ordinary iron hydrant or even through an iron rod thrust into the earth.

M. TEVIS.

## CRATER LAKE, THE SEA OF SILENCE

ONE of the most remarkable of our national scenic beauties is Crater Lake, Oregon; yet it is safe to say that millions of our people have never heard of it; and of those who have, only a few have visited it. There may be some excuse for this, as the lake must be reached from the railroad by auto-stage. But the ride is an inexpensive one, and a lodge on the rim of the lake provides comfortably for man and beast. The landlord also furnishes pack-horses, saddle-ponies, and rowboats; and visitors can fish, as well as enjoy marvelous scenery.

Crater Lake is a body of water of unbelievable blue, filling the crater of an extinct volcano in the southern part of Oregon. Of this, Joaquin Miller once wrote:

The lake? The Sea of Silence? Fancy a sea of sapphire set around by a compact circle of the great grizzly rocks like those of the Yosemite. It does not seem so sublime at first, but the mote is in your own eye. It is great, great! But it takes you days to see how great. It reflects its surroundings so perfectly that you can not tell the wall from the reflection in the intensely blue water. You have a continuous, unbroken, circular wall of twenty-four miles to contemplate at a glance, all of which really lying two thousand feet below you, seems to lie four thousand feet below.

Joaquin Miller is not alone in thinking Crater Lake one of the most beautiful spots in America; while geologists consider it the most interesting crater lake in the world. Their theory is that one of the most ancient of the volcanos of the Pacific coast was Mount Mazama. Perhaps it was as high as Mount Ranier; but no one absolutely knows, for in prehistoric ages the upper part of it, in some titanic cataclysm, fell in upon itself, leaving a deep hole surrounded by a rim of high peaks. Then, as the fires ceased, springs ran into the hole, and gradually a lake was formed, with no outlet, unless the water escapes through underground channels.

There is an air of mystery about this blue lake. This is why it is called the Sea of Silence. No one can explain its weird fascination. Perhaps it is because it changes so often with sunshine or shade or storm, moonlight and starlight. At any rate, the water takes on a thousand shades, but always remains blue, invariably blue.

In August, 1885, a movement was started by W. G. Steel, the present supervisor, to set aside this wonderful lake and the surrounding country for a national park. At that time it was but little known even to the

inhabitants of Oregon, though it was discovered as early as 1853, when some prospectors found it. They called it "Mysterious Lake" and also "Deep Blue Lake," but in 1869 it was renamed Crater Lake. In 1902, two hundred and forty-nine square miles, including the lake, were set aside. The crater has an area of five and a half square miles and is filled with water to a depth of two thousand feet, and the walls around it tower into the air five hundred to two thousand feet.

If you would go to this remarkable spot, you must take the train to Klamath Falls, Chiloquin, Medford, or Ashland, and thence by automobile. Between June and September is the best season to visit the park, and on the rim of the lake you will find Crater Lodge, built of stone, with good sleeping-rooms, and there are also outside camps. Many use the tents and take

you arrive so suddenly on the scene that the first discoverer wrote, "Not until my mule stopped within a few feet of the rim of Crater Lake did I look down; and if I had been



PHANTOM SHIP—AN ISLAND CONE

riding a blind mule, I believe I should have ridden over the edge."

There is now a motor road around the lake—one of the highest scenic highways in the world. It is thirty-five miles in length, and from it you can get a complete view of the lake. In places you can scramble over

the lava formations and look down into the blue depths. But the best way to see Crater Lake is to take a boat ride along its edge. Thousands of persons do this yearly, and visit Wizard Island and Phantom Ship. We call these "islands," yet, in reality, Wizard Island is a volcanic cone, emerging from the water to a height of seven hundred and sixty-three feet. How long it has been there, no man knows, but geologists say it is a lava-field and cinder-cone of comparatively recent eruption. It contains a perfect crater eighty feet deep,



LOOKING ACROSS CRATER LAKE

their meals at the lodge. As you approach the lake you see a cluster of peaks rising about one thousand feet above the general crest of the range. The road winds over a moraine dotted with lava boulders, and

presenting the phenomenon of a crater within a crater. It is a remarkable experience to camp on this island and watch the mysterious shadows of twilight, the myriads of stars, and the weird awakening of dawn.



Phantom Ship is another picturesque, but smaller, island cone which ought to be visited. The surrounding strangely shaped rock formations provide other points of interest on the boat trip. One of the most notable is on the northern wall of the lake—Llao Rock, named after an evil spirit supposed by the Indians to haunt the waters.

Such is Crater Lake, weirdly grand and mysterious, 6177 feet above sea-level, in the heart of the Cascade Range. Its real beauty lies in its magnificent coloring, the brilliance of which, when faithfully reproduced in paintings, seems exaggerated and impossible to those who have not seen the reality. Surrounded by cañons, ravines, and pinnacled rocks, and belted by a wilderness of forest, it lay undiscovered for centuries, until stories of the mysterious lake and buried mines led at last to it being seen by its white discoverers.

But this wonderful lake is by no means the only attraction in the park, for there are

mountain road to Crater Lake passes through this forest, and in it is the Natural Bridge of the Rogue River. The streams which rise in this forest water some of the best apple- and pear-producing regions of the United States, and there are three mineral springs within its boundaries. The air is warm and invigorating, crisp with the tang of high altitudes, and sweet with aromatic fragrance of pines.

So go to Crater Lake, this year, next year, any time. You will not be disappointed, but will have a memory ever to be cherished.

KATHERINE LOUISE SMITH.

### BANDIT-PROOF FREIGHT-CARS

IN the constant struggle which goes on in this world between the forces of good and the forces of evil, it is encouraging to find the former steadily getting the upper hand. The ingenuity displayed by daring outlaws in holding up mail-cars and looting freight-

trains has been check-mated by an ingenuity which makes their criminal exploits literally impossible. Our illustration shows one of the new mail-cars recently invented by Mr. A. H. Smith, the president of the New York Central Railroad, and now in constant use over that line, though it was first installed and demonstrated only last May.

These "container cars" are built on an entirely new design. They consist practically of a series of enormous steel boxes set in a specially constructed framework which includes a large

steel bulkhead, or fence, into which the containers are dropped and locked by grooves. There is not only a double lock on the doors of the containers, but the steel bulkhead makes it impossible to open the section while in transit. As our picture plainly shows, a powerful crane is used at each end of the trip to hoist them from the motor-truck to the car body, and vice-versa.

But these container cars have other points

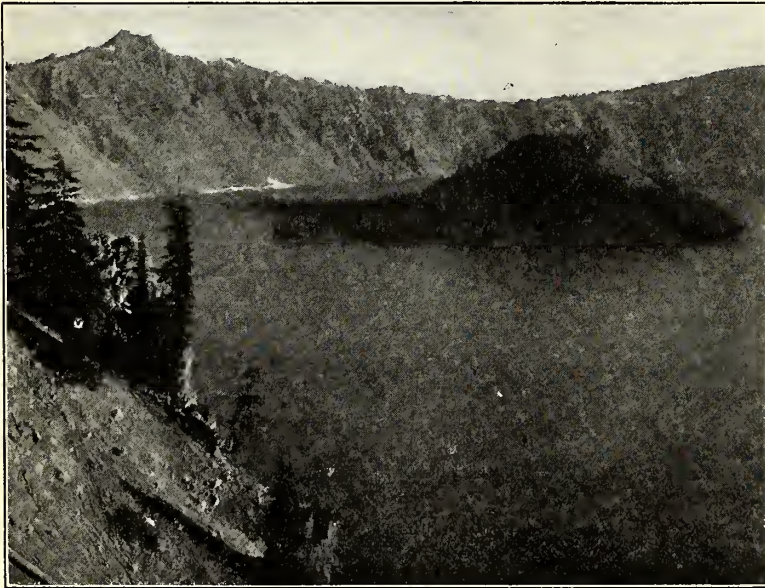

WIZARD ISLAND, WHICH CONTAINS A CRATER EIGHTY FEET DEEP

trips to Mount Thielsen, Diamond Lake, and other points, which require guides and camping outfits. You can go to The Watchman and Glacier Peak, the highest point on the rim, for views of Phantom Ship, and to Sentinel Rock to get the most comprehensive view of the whole expanse.

Surrounding Crater Lake National Park on three sides is the Crater National Forest of a million and a half acres. The picturesque

of great value besides being proof against robbers. In the first place, they carry considerably greater cargo than the mail storage cars hitherto employed. The first load sent over the road in these cars had a gross weight of 34,650 pounds, the previous average being only 30,000 pounds. But the container car can easily carry 50,000 pounds or more, since there are nine of the steel boxes, each of which is capable of carrying 7000 pounds. Another point in favor of these cars is that their strength protects the mail from damage. The first postal cargo shipped in them went through without the loss or mutilation of a single letter or package.

One thing about them that railroad men prize particularly is the greater rapidity with which they can be handled, which not only means a saving of time and money, but relieves congestion at terminals. This is admirably illustrated by an actual instance. A car carrying nine containers arrived at Chicago from New York. The containers were transferred to the motor-truck used for delivery in from three quarters of a minute to three minutes each, so that the car was entirely cleared in twenty minutes. The truck delivered the first container to a department store a mile away in thirty-eight minutes, while the second container reached the consignee at a distance of five miles in one hour and fifteen minutes. The importance of this is seen when we learn that, under the old system, forty-eight hours is the average time wasted at freight stations. Another time-saving element consists in the elimination of heavy packing, since, because of the strength of the containers, light wrappings are all that is necessary.

Since the containers are of uniform size, they are interchangeable, and when distributed in large numbers, they can be kept ready for packing and unpacking on shipping platforms without tying up the rolling-stock and congesting the tracks.

The cubic capacity of each container is

438 cubic feet, and its weight capacity 7000 lbs., as stated. They are not only burglar-proof but practically fire-proof and weather-proof as well. They have wooden floors of an especially durable type, called "haskalite" floors. The roofs have a hook at each outside corner to enable them to be conveniently

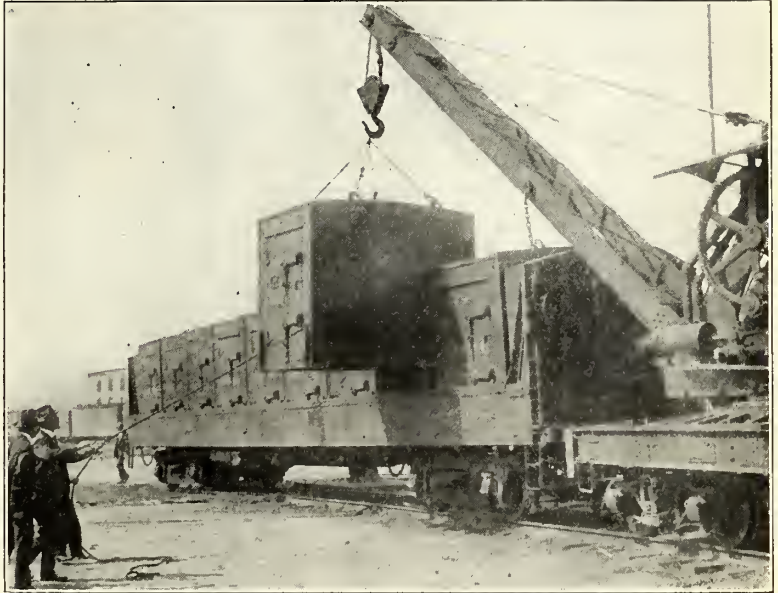

Photo by Underwood & Underwood

UNLOADING THE FIRE- AND BURGLAR-PROOF CONTAINER CARS

lifted and handled. The doors are of the standard refrigerator-car design and are equipped with a hasp and staple to carry the post-office padlock and also with a pin and a slot for the railroad company's car-seal.

An interesting feature inside the body of the car consists of the sectional guides made of quarter-inch steel. There are guides at each place on the inside of the car where the corner of the container will lie, while at each corner on the length side of every container is a steel "shoe," fitting into the guide which is riveted to the side of the car. By this means, the containers are safely guided to the floor of the car and held firmly in place without additional blocking or fastening, while the car is in transit. Even when one or more containers have been removed in the course of a long trip, the guides and shoes hold the others in place, so as to prevent them from shifting their position or tumbling over; the advantage of this arrangement is readily perceived by anybody who has ever tried to pack a trunk without quite enough goods to fill it tightly!

DONOVAN MCCLURE.



## FOR VERY LITTLE FOLK



“WHY DON'T YOU PULL IT OUT?” ASKED WALTER”

### JAMIE'S DENTIST

By LUCY EDWARDS BRUCE



JAMIE had a loose tooth; but he would not have it for long, as it was very, very loose. It was just a tiny baby-tooth, right in front, and every little while Jamie would wiggle it with his finger and show Mother how very trembly it was. Although it annoyed him a great deal, he would not permit Mother or Father to pull it out. They suggested that he go to the dentist, but he loudly objected to that.

So Jamie continued to fuss, and Mother kept on coaxing, and the little wobbly tooth remained right where it was.

One day, little Walter, Jamie's friend, came over to play. For a long while he and Jamie had a fine time playing with Jamie's wagon, and his small black-and-white kitten; when all of a sudden Jamie thought about his loose tooth and began to complain.

“Why don't you pull it out?” asked Walter.

“How can I?” grumbled Jamie.

“Humph! that's easy! All you have to do is to tie a strong thread to it and open the door; tie the other end of the thread to the door-knob, and shut the door.”

“I don't see how that can pull out a fellow's tooth,” argued Jamie.

“Well it certainly can! That's the way I pulled out mine!”

“Did it hurt?”

“Not a bit; course not! Let me show you!”

“No, I am afraid it will hurt.”

“Hurt! Pooh! You are a cowardly calf! If it did n't hurt me, how can it hurt you?”

“Maybe your tooth was littler—or looser—or—or—something,” hesitated Jamie.

“Really, Jamie, that is a splendid way,” encouraged his mother. “I did that once when I was a little girl, but I did n't think to tell you about it. I shall get a thread and we shall have the tooth out in half a minute.”

“No, I don't want to,” whined Jamie.

“I would n't be a cowardly calf! I was brave!” bragged Walter.

“Humph! you are no braver 'n other boys,” replied Jamie.

“He certainly was braver than you,” said Mother. “I would show him that I was courageous too, if I were you.”

“I *am*—just as much as he is,” asserted Jamie, holding his chest a little higher.

“Shall I tie the string on?”

“Ye-e-s, I guess so.”

So his mother tied the thread tightly to the troublesome little tooth, opened the door, and started to tie the other end of the string to the door-knob, but Jamie objected and walked away from the door, letting the loose end of the string fall to the floor.

"No, wait a minute."

"Why wait?"

"I am not ready to have it pulled out."

"Really, Jamie, you are exasperating! You *must* have it out; it is right in the way of another little tooth which should have every chance to come in nice and straight, which it can not possibly do if—"

"Oh, Mamma! the kitty has run off with my thread!" interrupted Jamie, in surprise.

"What?" His mother turned around to see, and sure enough, there was the mischievous little kitten clear at the other end of the room with the thread! "Why, how did it ever come off of your tooth? I tied it very tight!"

"I don't know," replied the puzzled boy.

"Oh, Jamie! here is your tooth!" exclaimed Walter, who had run after the cat.

"Where?" asked Jamie's mother.

"Right here, on the end of this thread! See!" and Walter picked up the thread and showed them the tooth.

"Is that—*mine?*" asked Jamie, greatly perplexed.

"It certainly is a little baby-tooth," admitted his mother. "Let me look in your mouth. Yes, your little loose tooth is gone!"

"The kitty pulled it out!" laughed Walter.

"That 's funny," grinned Jamie, and the space appeared very large where the little tooth had been. "Why did n't I feel it?"

"Did n't I tell you it would n't hurt?" chimed in Walter.

Jamie laughed then, and his mother laughed, too, and Walter joined in the fun.

"Come here, kitty," Jamie said, taking the cat up in his arms; "you certainly are a fine little dentist!"



"'THE KITTY HAS RUN OFF WITH MY THREAD!' INTERRUPTED JAMIE, IN SURPRISE"



# ST. NICHOLAS LEAGUE.

THROUGH a fortunate circumstance in the make-up of the May ST. NICHOLAS, the editor was able to allow the LEAGUE nine pages—one more than its usual number. In doing so, he thought the extra space would take care of several additional contributions and so his task of selecting the material for publication would be simplified. But the additional page offered little help. There were just as many meritorious contributions omitted, for lack of space, as usual.

The LEAGUE young folk surprise us every month with the excellence of their work. One might think that the occasion for surprise would have passed long ago, but the fact is that each time the contributions are considered and selected we are as impressed with their quality as much as we were the first time we ever approached the task.

Task is not altogether the proper word, for it suggests toil and burdensome employment, and the consideration of the LEAGUE material falls within the bounds of a pleasant recreation.

One quality pleasing to note in the prose, verse, photographs, and drawings, is the humor displayed by our LEAGUE members. Every editor finds humor one of the most difficult things to secure, and sometimes, when he thinks he has found it in a story or in a drawing, it has vanished when he sees the proof, and he asks himself, "Why did I ever think that was funny?" But in many of our LEAGUE contributions the humor is spontaneous, entirely unaffected, and with an aptness in fitting the subject such as one rarely sees.

One reason, perhaps, there is such prevailing excellence among our contributions is that the work is not "forced." In school classes, occasionally, some things *must* be done, and the "must-be-dones" haunt one for days, and then are often



BY WORTHEN BRADLEY, AGE 17. (HONOR MEMBER)

hastily finished at the last minute. We are glad to think that for the LEAGUE, our members write or draw or make photographs just because they love to. And most things done for the love of doing them are well done.

## PRIZE COMPETITION No. 266

(In making awards contributors' ages are considered)

**PROSE.** Gold Badges, **Alma M. Hopkins** (age 17), New Jersey; **Josephine Miles** (age 10), California; **Betty Fry** (age 15), Pennsylvania. Silver Badges, **Emily Ashe Smith** (age 14), Alabama; **Frances G. Maher** (age 13), New York; **Margaret H. Collins** (age 13), Pennsylvania; **Emily Lee Brandt** (age 12), New York; **Elizabeth Cattelle** (age 14), New Jersey; **Madeline Blossom** (age 10), New York; **Louise Heilbronner** (age 10), New York.

**VERSE.** Gold Badges, **Ralph Sargent Bailey** (age 17), Massachusetts; **Virginia P. Broomell** (age 12), Pennsylvania. Silver Badge, **Susan Clayton** (age 15), Georgia.

**DRAWINGS.** Gold Badge, **Ruth Whitten** (age 13), Indiana. Silver Badges, **Mary E. Stonebauer** (age 14), Ohio; **Doris Hatch** (age 15), California; **Betty Spadone** (age 13), New Jersey; **E. Virginia Grimes** (age 13), Pennsylvania; **Alice Sadler** (age 15), Utah.

**PHOTOGRAPHS.** Gold Badge, **Helen F. Corson** (age 15), Pennsylvania. Silver Badges, **Ellen Forsyth** (age 12), New York; **Clara Louise West** (age 11), California; **Gardner Barker** (age 13), Massachusetts; **Mildred Goosman** (age 11), Nebraska; **Oliver Evans** (age 12), Pennsylvania; **Ruth Lyon** (age 14), New York; **Salem Hyde, II** (age 16), Illinois.

**PUZZLE-MAKING.** Gold Badge, **Margaret Peck** (age 16), Rhode Island. Silver Badges, **Catherine Watson** (age 14), Ohio; **Harry Bowen Brainerd** (age 14), Massachusetts.

**PUZZLE ANSWERS.** Gold Badge, **Susan E. Lyman** (age 16), New York.

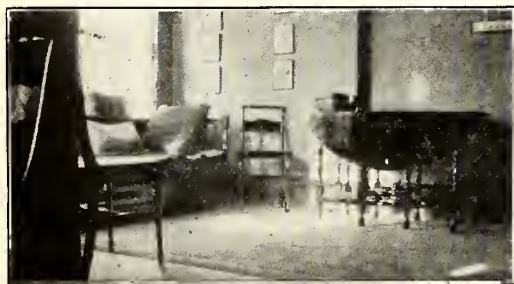

BY MILDRED GOOSMAN, AGE 11. (SILVER BADGE)



BY RUTH LYON, AGE 14. (SILVER BADGE)

"A SUNNY CORNER"

## LOST AND FOUND

BY ALMA M. HOPKINS (AGE 17)

*(Gold Badge. Silver Badge won May, 1916)*

ONCE upon a time, when Father was a little boy, he and his father and mother were traveling in a stage-coach from Marysville, Montana, to Cheyenne, Wyoming. After traveling all day and night they reached a tavern at daybreak. There the weary travelers ate their breakfast and heard the unwelcome news—road-agents were after the coach, which carried thousands of dollars' worth of gold-dust.

Grandmother was worried. Traveling was bad enough, without being held up by road-agents. In spite of all she could do, it was hardly daylight when they started.

There was no sign of the road-agents until later in the morning, when suddenly a shot rang out above the sound of the coach wheels. Grandmother and Father were ordered to sit on the floor of the coach, while Grandfather and the guard fired at the bandits. It was a wild chase down a rocky, mountain trail, with furiously galloping horses.

After a while the road-agents gave it up as a bad job. Grandmother began to gather herself and her possessions together. Everything was there except her opera-glasses. They had mysteriously disappeared! She did not feel too badly about it, for in those days you were lucky if you came off without being injured, to say nothing of losing valued possessions.

Three years later they were stopping at a hotel in Cheyenne. A knock came at the door. Grandfather opened it and found a package containing the opera-glasses!

The only explanation of this is that the glasses were found by the road-agents after the hold-up. They were engraved with my grandmother's name, and as they were the only Hopkins in the territory, one of the road-agents thought he would return them to her. I've often wondered whether he had a conscience, or a sense of humor. Which do you think?

## AT BREAK O' DAWN

BY HELEN L. RUMMONS (AGE 15)

*(Honor Member)*

DARKNESS on the prairie;  
Darkness like a pall over the prairie city;  
Darkness, like a deep pool, in the little street;  
Darkness on the hill where the church is;  
Darkness in the valley behind the church:  
Darkness, desolate and barren, like a theater with the lights put out.

It is a theater, and each of us must play his part on the great stage we call the world.

Some of us will have the center of the stage,  
And the roof will ring with clapping,  
And there will be flowers sent across the footlights;  
And some of us will say our two-word parts, unnoticed and unpraised;  
And some of us will play in tragic rôles; and some in comic.

Who knows that, ere the play is done, the lights for some will not be dimmed forever?

Who knows but some, who still have lingered near the wings, will feel the spot-light's dead-white eye upon them?

The church looms up against a gray-white something—nothing.

There is a vibrant hush of expectancy, as when the footlights are about to be lighted.

The valley behind the church is full of pink and gold and purple lights;

The Cross above the church is touched with sun; The darkness melts, down in the little street;

The pall is lifted from the prairie city.

The sun is risen on the prairie!

The stage is set; the lamps are lighted;

Let the play begin!

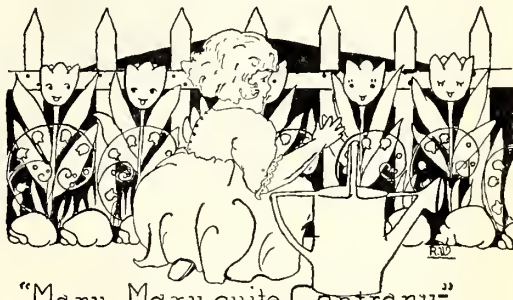

"Mary, Mary, quite Contrary"

"BUSY." BY RUTH WHITTEN, AGE 13. (GOLD BADGE. SILVER BADGE WON FEBRUARY, 1922)

## FOUND AND LOST

BY JANE BUEL BRADLEY (AGE 13)

*(Honor Member)*

THE following anecdote is a supposedly true tale, but it is amusing, at least, and, as has often been said, "A laugh is the greatest thing in the world." So I have set it forth in the hope that it will make some one happier for the moment.

Not long after the beginning of the Civil War, the southern army suffered from the pangs of hunger, for little or no food was obtainable.

Cabbage was the Confederates' main diet; and although better food would have been provided for the officers, they were too just and kind to take what their men could not have, and so lived upon the soldiers' simple fare.

One Sunday in May, 1862, General Lee invited three of his officers to dine with him, and as soon as they were seated on the rough boxes placed around the unpretentious wooden table, the universal army dish was brought in by the grinning colored cook; and as it was set on the table,—wonder of wonders!—what was placidly reposing on top of the cabbage, its tender pink delicately browned, but a small piece of salt pork—a rare treat in those meatless days!

But all the guests, each wishing the other to have the pleasure of eating it, and knowing that there would not be enough if it were divided, unselfishly refused the tempting bit, and so it was left uneaten.

The next day at luncheon, General Lee asked for the salt pork which had been served the day before; but to his surprise, the black boy said, as if it were the most natural thing in the world, "Law, why, Massa, ah jes' borrowed dat bit o' pohk fo' de 'casion, an' ah done tuk it back yestiddy."

Alas! the precious morsel had been found, but to be lost!





"A SUNNY CORNER." BY SALEM HYDE, II, AGE 16  
(Silver Badge)

THE BREAK O' DAWN  
BY SUSAN CLAYTON (AGE 15)  
(Silver Badge)

A THROBBING darkness, trembling hush,  
And then—a misty light,  
The dimmest stroke of daylight's brush,  
Breaks through the gloom of night.  
The dawn with pearl and opal hint  
Its mystic message brings,  
Traced somewhere in the lovely tint  
Of widespread, fluttering wings.

Come, watch with me the dawning break  
O'er hill or dale or sea.  
It matters not where you awake,  
So long as you 're with me;  
For we can see the darling dawn.  
Its splendors soft disclose  
In fairest etchings ever drawn,  
Faint violets and rose.

Your eyes are like the dawn to me,  
The dawn in glory pure;  
They shine in nameless ecstasy,  
With love that shall endure.  
The break o' dawn in heaven high  
Can hold me in its thrall;  
But break o' dawn in your dear eye  
Is worth the world and all.

LOST AND FOUND  
BY EMILY ASHE SMITH (AGE 14)  
(Silver Badge)

"LAWS-A-MERCY! what am I gwine ter do wid dis? Dat fool baggageman had dis box loaded on ter here. He ain't got no realization ob de 'sponsibility ob his avocation."

The porter brakeman and conductor all stood gingerly around a small, black, shiny box, labeled, "TNT"!

"Hit 'pears to me, dat dis TNT wuz loaded on ter de wrong train, er else some one has just nachedly proved hissef malicious," said Rastus. "We are not authorized to carry TNT, and this is a through train. The slightest jolt will send it off. We 'd better heave it into the next river we pass."

"Yass, sah, yass, sah," said Rastus, grinning.

In the city of X—. Thomas Newton Trent was scolding his valet:

"Has that hat-box come yet?"

"No, sir; the baggageman said it would be sure to be on the next train, sir."

"Well, it 's only three hours until the big dance, and I 'm not going without my topper. The stores are closed downtown and I can't borrow one anywhere."

"Very sorry, sir," said the valet, concealing a grin.

Thomas went down to the station himself. He had only just arrived that day, and his hat-box had not come in on the same train he had. Loud voices caught his ear.

"Yass, sah! It floated as sure as I 'm a-livin'!" exclaimed one.

"Why, you 're crazy, man; it 's heavy enough to sink."

"Dey ain't no tellin' what TNT am liable ter do," said Rastus, rolling his eyes, for it was he.

Thomas pricked up his ears at this and asked the baggageman if his hat-box had been found.

"Rather small, shiny, black box with initials TNT on it," he described.

"Golly, boss! Dat 's de ve'y box," cried Rastus. "Yass, sah, dat box am floatin' down de Missip' right now."

When Thomas Newton Trent left, still fuming angrily, Rastus said to himself: "Brains, you has did yo'self proud! Won't dat hat look grand ter wear ter de next lodge-meetin'? Nigger, it ain't fo' nothin' you looked in dat box!"

BREAK O' DAWN

BY RALPH SARGENT BAILEY (AGE 17)  
(Gold Badge. Silver Badge won May, 1921)

WHEN weary earth is rested, and the night,  
In answer to the beck of Time's slow hand,  
Calling his legions from their drowsy watch  
On land and sea, prepares to make retreat  
And leave a world refreshed to greet the morn,  
All life is still. Each smallest leaf  
Forgets to tremble at the awesome dark;  
The ceaseless fountain in a woodland glen  
Mutters in slumber on his mossy couch;  
The mighty river guides his dusky way  
In tranquil silence to his journey's end;  
Winds that have sighed the purple seas to sleep  
Retire within their far Æolian caves.

The flick'ring stars wink out, one after one,  
And join the moon, long hid behind the hills  
That grope, vague phantoms, to the sightless sky.  
Nature gathers wondering breath—and waits—

Now suddenly, the black veil in the east  
Is lifted, and a slender band of gray,  
Half-stained with morning's blood, creeps  
stealthily

Along the jagged rim of mountain peaks;  
A salt wind slips across the quiet fields.  
Sets all the grasses whispering in its train,  
And wakes the forest with its cooling touch.

Then through the silver haze of twilight mist,  
Up to the very summit of the world,  
An eager lark swift wings his blithesome flight,  
And with the magic sweetness of his song,  
Heralds the coming of triumphant day.



BY ELLEN FORSYTH, AGE 12  
(SILVER BADGE)



BY GARDNER BARKER, AGE 13  
(SILVER BADGE)



BY MARY E. WHITESIDE, AGE 14



BY OLIVER EVANS, AGE 12. (SILVER BADGE)



BY EVELYN JAFFE, AGE 10



BY MARGARET KIP, AGE 13

"A SUNNY CORNER"

LOST AND FOUND—A TRUE STORY

BY FRANCES G. MAHER (AGE 13)

(Silver Badge)

ONE summer several years ago, my aunt, while bathing in the ocean on the Long Island coast, lost a gold, flexible bracelet, set with sapphires, which she treasured very dearly.

Although much upset by her loss, she realized that in all probability the current had already carried it away.

One day early the next summer, after her return to the sea-shore, the incident of the bracelet practically forgotten, something occurred to remind her of it.

The old man who for years had taken charge of the beach approached my aunt and asked her if what he had heard about her losing her bracelet was true, and if so would she describe it.

As she finished her description she was rewarded by seeing a look of incredulous amazement creep over the old wrinkled face of the man.

"Well, Miss," he declared, "ye shure got luck!" and he handed her the lost bracelet.

He then explained that in cleaning up the beach in readiness for the bathing season, he saw something glittering in the sun, which proved to be a bracelet.

He then started to find out to whom it might belong, and learned that my aunt had lost one the year before.

We all thought that the finding of this bracelet was quite remarkable.

Another interesting fact connected with this story, is that the bracelet after its year's journey was in perfect condition, no stones missing, and the gold even more polished than when it disappeared.



## BREAK O' DAWN

BY VIRGINIA P. BROOMELL (AGE 12)

*(Gold Badge. Silver Badge won October, 1921)*

ARIEL, Ariel, spirit of spring!

The night has departed, with shadows and stars;

The dawn-sky is radiant, the lark-herald sings;  
Apollo has broken his cloud-prison bars.

Ariel, hasten, with music and light,

A soft rush of fragrance and sunshine and dew!  
Fly to the wide earth and scatter your joy—

Hark! for aurora is calling to you.

Ariel, hasten, O spirit of spring,

To the hearts of the people and heart of the earth,

Bring springtime and joytime, dawn-time and light,

And all of thy spirit's true gladness and worth.

Ariel, pause in thy swift, eager flight;

To the one that I love these blessings impart—

All the lark's melody, all the dawn's light,

Joy to her eyes, and love to her heart!



"A SUNNY CORNER." BY JEAN M. WIEGAND, AGE 15

## LOST AND FOUND

*(A True Story)*

BY MARGARET H. COLLINS (AGE 13)

*(Silver Badge)*

ONE afternoon, a woman who was spending last summer in the Adirondacks, started for a walk, expecting to climb Noon Mark or Roundtop.

After the sun had set and it became dark and she had not returned, her friends began to feel alarmed, thinking that she might have attempted to climb Roundtop. Although that is a rather low mountain, it is by the side of a dismal lake called Chapell Pond, and rising from its shore are great high cliffs. If she had tried to climb this mountain alone and without knowing the trail, she might have easily lost her way. So search-parties were at once sent out. Late in the night they returned, unable to find her.

Early the following morning an automobile was going along Chapell Pond Road when the driver happened to look up at Roundtop, and there, high up on a small ledge of rock, stood a woman, waving her hands frantically, trying to attract attention. He knew that she was in need of help, so he went to the inn as quickly as possible, and reported what he had seen. The people at the inn thought she was the woman who had been lost

the evening before, and sent out at once men with ropes, in case they might be necessary, to rescue her and bring her home.

And sure enough! about lunch-time they all returned, bringing her with them, saying that they had found her on a ledge of rock, where she had fallen and was unable to climb up or climb down, so there she remained all night. With some difficulty they finally pulled her up by means of the ropes.

And I think after that experience she was not anxious to climb a mountain again alone and without a trail.

## LOST AND FOUND

BY JOSEPHINE MILES (AGE 10)

*(Gold Badge. Silver Badge won February, 1921)*

THE Green Forest was in an uproar. All the animals and birds were gathered in front of the news-board on Wise Owl's tree, because in the Green Forest they did not have newspapers. Even old Mr. Beaver stopped his work to see what was the matter.

For on the news-board at the very top it said: LOST,—A LAUGH. PLEASE RETURN TO BROOK. Now it was a terrible thing in the Green Forest to lose a laugh, for there everybody worked with a laugh, played with a laugh, lived with a laugh.

"I wonder how Brook lost it," said old Mr. Beaver.

"I think somebody stole it!" cried Sly Fox. "Yes," said Woodchuck, "but who? Nobody in the Green Forest would steal."

"Of course not!" cried all the animals, "of course not!"

"I know," said Rabbit; "let's ask Owl what he thinks."

"What I think?" said Wise Owl's deep voice; "I think Jack Frost took it."

"Jack Frost!" the animals gasped. "Jack Frost?"

"Yes, Jack Frost," answered Wise Owl; "and the only way you can get the laugh back is to find Spring."

"Then we'll have to find Spring," said Woodchuck, "for we must find Brook's laugh."

"But who will go?" asked Sly Fox. "The snow is very cold."

"I will," said Bluebird, bravely. Then all the animals cheered for her, and Bluebird flew away.

For two long months Brook's friends waited, and then, on the first of March, Bluebird came flying back with Spring. Then suddenly, down where the Brook flowed, they heard a merry murmuring. The Brook's laugh was found!



BY BETTY SPADONE, AGE 13. (SILVER BADGE)

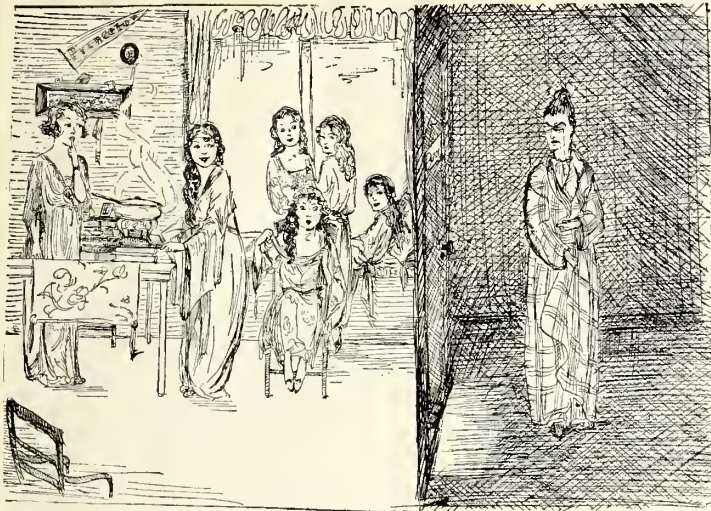

"BUSY." BY MARY E. STONEBAUGER, AGE 14  
(SILVER BADGE)



"A HEADING FOR MAY"  
BY DORIS HATCH, AGE 15. (SILVER BADGE)

LOST AND FOUND

BY EMILY LEE BRANDT (AGE 12)  
(Silver Badge)

It was April, 1865. Danville, Virginia, the last capital of the Confederacy, lay quietly among her green hills.

General Beauregard left the Sutherlin mansion, where he had been in conference with President Davis, and urged his horse wildly down Main Street, murmuring to himself as he rode, "But—surrender!" When he reached the country, he rode more slowly, admiring the scenery.

Soon Beauregard saw by the road a child, weeping bitterly. He inquired as to the trouble. "I lost my way, sir," said the girl, regarding him with interest, "and I fell asleep, and some one stole Mother's eggs."

"Bah!" with a shrug. "Where do you live?"

"Green Street—Danville," sobbed the child.

"Don't cry. I'll take you home." Then, placing the child on his horse, Beauregard turned back to Danville. As they rode, he asked her name.

"Nancy Davenant," she said. "What's yours?"

"General Beauregard."

"I've heard of you. Going to surrender?"

"I must."

"Do you want to?"

"No! No!" groaned the Louisianian.

"Why do it?"

"Mr. Davis wants me to."

"He does n't understand—why obey?"

"Because he is President."

Just then a ragged soldier saluted the general, who returned the greeting. The soldier cast a glance at Nancy. "Daughter!" he cried, leaping forward, "Nancy!"

"Father is dead—he fell at Petersburg," said Nancy, proudly.

"No, I was captured and released at Lee's surrender!" cried the soldier.

He continued with them, and finally the little group stood before Nancy's home. With a cry of rapture, Mrs. Davenant rushed into the soldier's arms, and then embraced her lost child.

"Father," said Nancy, that evening, "we're two of 'em, are n't we?"

"Two what?"

"Two 'lost and founds'!"



"A HEADING FOR MAY." BY DORIS E. MILLER, AGE 16  
(HONOR MEMBER)

LOST AND FOUND

BY BETTY FRY (AGE 15)

(Gold Badge. Silver Badge won January, 1922)

TOM ALLEN's only vice was a passion for collecting choice bits from the "Lost and Found" department of the local paper. He had in his collection such things as these: "Lost—A ring by a lady of no value."—"Found—A small green gentleman's pocketbook," etc., etc.

One day when I arrived at the office he jumped on me with this one: "Lost—A handsome gentleman's diamond tie-pin." Just as I finished reading it, in walked the boss. Tom always was a reckless, daring fellow, so what did he do but go up to him and say: "Look here at what some poor old goof put in the paper. Handsome! I'll bet he's as ugly as a monkey! Why, if I could n't do better than that, I would commit suicide!"

The boss read it and then looked at Tom. "Young man," he said quietly, "you may draw your pay. Good day."

"Wh-what!" said Tom, looking a bit ill.

"I wrote that myself," said the boss.

The boss is very homely!





"A SUNNY CORNER." BY HELEN F. CORSON, AGE 15  
(GOLD BADGE. SILVER BADGE WON AUGUST, 1921)

### LOST AND FOUND

BY ELIZABETH CATTELLE (AGE 14)  
(Silver Badge)

ONCE, when walking through a wood, I stopped to pick some violets. Kneeling in the shade of a giant tree, I saw, close by a large stump, the most exquisite flowers I had ever seen. Wishing to add some plants to my wild-flower garden, I dug up several and lifted some pieces of moss in which to wrap them.

When finished, I noticed, lodged in the stump from which the moss had been taken, what seemed to be a gray stone. I dug into the stump with my knife, and was able to pull out the object. To my joy, it was an arrow-head.

I love to find tokens of times past, so I idly leaned back and dreamed.

It was night, so I thought, and a huge red hunter's moon looked down on still forests, between bars of black cloud. Through the somber wood, a small band of Indians glided, their bronzed chests bared to the cold night air. In their midst slunk five prisoners, with arms bound by deer thongs. Along the gloomy trails they hastened, passed the glassy lake and white tepees, passed where embers of their own fires glowed, and into the forest beyond.

Here the captors surrounded their prisoners, cut their bonds, giving to each a bow and brightly dyed arrow, each of a different color.

"Shoot! If we no find arrow, you live; if find, you die." The chiefs spoke.

In the still night came the whiz of five arrows, one by one.

Next morning, the chief spoke once more: "Four arrow found. Red arrow lost. Man shoot red arrow go!"



BY E. VIRGINIA GRIMES, AGE 13  
(SILVER BADGE)

I still prize the "lost" arrow-head, that I, after so many years, had found.

### LOST AND FOUND

BY CHARLES E. CRAWFORD (AGE 12)

AT a summer camp that I go to, there is a lost-and-found room in the library. Anything found lying around, not being used, must be taken there. A fine of two cents must be paid by the owner before the article may be taken away. Every three weeks the fine is doubled. Everything not taken by the end of the season, is taken by the camp director, who thus gets his winter supply of knives, etc.

A trick played is to take an article belonging to another boy down to the lost-and-found room.

You can get a two-dollar-and-a-half baseball for two cents, and then have the ill luck of finding the owner and having to give it back to him.

### LOST AND FOUND

(A True Story)

BY MADELINE BLOSSOM (AGE 10)  
(Silver Badge)

MUFFY was the household pet—a dainty gray kitten, with soft white paws and an adorable little pink nose. Somehow, Muffy always escaped most of the scoldings she deserved, for she was so cunning that nobody had the heart to scold her.

As I went to bed one night my mother called, "Where is Muffy?"

"Is n't she with you?" I asked, anxiously.

But Muffy was not, and we searched for her in vain. We were sure that some one must have opened the door, and that she had slipped out in the big apartment-house and been lost. Ringing the bell, I asked the elevator-men if they had seen her, but they had not.

I went to bed with a heavy heart. Home would not be home without Muffy to run in it, Muffy to play in it.

My music-lesson was the next morning, and slowly and sadly I arranged the music and opened the grand piano.

What I saw made me transfixed with astonishment and joy. For 'way back on the piano, curled up lying fast asleep on the sounding-board, was—Muffy!



BY ALICE SADLER, AGE 15  
(SILVER BADGE)

### AT BREAK O' DAWN

BY MAISRY MACCRACKEN (AGE 12)

At the break o' dawn, when the rooster crows,

And the farmer's wife stirs in her bed;  
The farmer gets up and puts on his clothes  
And goes out, for the cows must be fed.

The farmer's wife wakes and looks at the sky,  
And she drowsily gives out a yawn;  
She gets out of bed and dresses herself,  
For she sees 't is the break o' the dawn.



BY PENELOPE W. CRANE, AGE 14



BY LOUISE E. BALDWIN, AGE 16



BY MYRA NEWBORNE, AGE 14

## "A SUNNY CORNER"

## BREAK O' DAWN

BY DOROTHY ANNE GUILD (AGE 13)

O'ER the darkened tree-tops, there came a wild  
sweet song,  
Hark! 't is Pan that 's piping—of the coming of  
the dawn.

The music thrills through bough and trees,  
For Pan sees what no mortal sees—

The coming of the dawn.

The liquid notes fling far abroad their welcome  
to the new-born day,

As Pan advances down the dim-lit arches of the  
forest gray.

And lo! the eastern sky-line turns to pink from  
midnight hue,

While opal tints of gold and green are spangled  
on the blue.

There 's a soft murmur undefined of living things  
awake,

As in the east the rolling clouds their fluffy masses  
break,

And bank themselves like soldiers who come to  
guard their king,

While, from the forest tree-tops, all birds begin to  
sing.

## LOST AND FOUND

(A True Story)

BY LOUISE HEILBRONER (AGE 10)

(Silver Badge)

"WELL, children, so you think there is nothing  
interesting in history. Have you never heard  
the story of Pompeii?"

"Well, it happened this way. A long time ago  
there was a city named Pompeii. It was situated  
near a volcano called Mount Vesuvius. This  
volcano was considered harmless, but one day  
it did a strange thing—it started to discharge  
lava. The city was completely covered, and for  
a long time was lost to the world.

Hundreds of years afterward, a man who had  
built his home on the spot where Pompeii had

been, began to dig a well, and, in doing so, found  
some of the ruins of the long-lost city. After  
that, people began to dig, and they have now  
uncovered the entire city of Pompeii. This is the  
story of the city that was lost and found.

## THE BREAK O' DAWN

BY FREDERICK STARK PEARSON II (AGE 9)

I LOVE to watch the break o' dawn,  
Upon the distant sea;  
It makes the water shine with gold,  
Like tinsel on a tree.

And when at last the colors go,  
The water gleams more bright,  
For then a flaming fiery orb,  
Makes all the world a-light.

"A SUNNY CORNER." BY CLARA LOUISE WEST, AGE 11  
(SILVER BADGE)



## SPECIAL MENTION

A list of those whose work would have been used had space permitted:

## PROSE

Marjorie  
Van Schaick  
Dorothy Scharlout  
Edith N. Cook  
Lucille Breeding  
Mary A. Hurd  
Phyllis B. Smack  
Alice Laster  
Katherine Lieb  
Jean C. Howe  
Anita Cordozo  
Isabelle Johnston  
Mary M. Crapo  
Ralph Ormsby  
Phyllis E. Knox  
Elizabeth E. Hughes  
Dorothy J. Miller  
Helen Gunn  
Winston Ashby  
Jane Ashcroft  
Lucy B. Sperry  
Margaret P.  
Coleman  
Louise E. Rodney  
Rachel Knox  
Angelica S. Gibbs  
Charlotte E.  
Farquhar  
Annie Rivers  
Marian R. Ballin  
Margaret W.  
Renwick  
Mary J. Kosegarten  
Arden Pangborn  
Pauline Garber  
Mary E. Elmer  
William Scott  
Grace Long  
Agnes Monagan  
Eva L. Hourwich  
Elinor Cooke  
Frances K. Beckwith  
Adelaide Humphrey  
Isabella R. Williams  
Mildred Ridley  
Dorothy M. McNeil  
Phyllis Dale  
Elizabeth A.  
McHugh  
Edith Callaghan  
Lael Tucker  
Harold Augur

Elizabeth Eastland  
Arthura Ebert  
Mary F. Daepfers  
Helen Holbrook  
Mary Churchill  
Adrian S. Rogers  
Jane Harwell  
Jane D. Wilson  
Wilhelmina Rankin  
Isabel E. Smith

## VERSE

Mary E. Crosley  
Margaret C. Fassitt  
Zarepha Sallume  
Molly Bean  
Ruth P. Fuller  
Katherine Foss  
Margaret Colwell  
Margaret McHugh  
Katrina Hincks  
Imogene H. Steeves  
Dorothy R. Burnett  
Margaret Humphrey  
Charlotte Churchill  
Margaret Mack  
Prang  
Phyllis Hodges  
Hoyt Hilton  
Caroline Harris  
Marjorie C. Baker  
Elizabeth Hardaway  
Estelle Parley  
Karl Heintz  
Virginia Parrette  
Eva Van Winkle  
S. C. Solum  
Katharine H.  
Chichester  
Doris C. Boardman  
Margaret Durick  
Virginia Farrington  
Ruth Meade  
Gladys Phillips  
Elizabeth G.  
Zalesky  
Merrill Jones  
Norma L.  
Sherburne  
Richardson  
Blanche Zelfie  
Elizabeth Brainerd  
Mary Arrington

Winifred Dysart  
Catherine Crook  
Madelaine Givan  
Edith Roth  
Helen L.  
Whitehouse  
Charlotte L. Groom  
Elinor G. Welch  
Ann Sommerich

## DRAWINGS

Mary F. Dakin  
Thomas Barrett  
Tyson Allen  
Dorothy Manning  
Grace Herman  
Evelyn Wermuth  
Eleanor Coryell  
Lillian Aspell  
Helen Milan  
Shirley Strouse  
Lois Gilbert  
Betty Cunningham  
Marion Welker  
Mercer Orwig  
Margaret Smead  
Harriet L. Jones  
Mary A. Peyré  
Gwynne M. Dresser  
Susannah R.  
Deacon  
Alison Farmer  
Dorothy Jayne  
Kathleen Murray  
Alice MacLean  
Hope Nelson  
Edith C. Reid  
Thomas E. Rooney

## PHOTOGRAPHS

Viola Finn  
Marie Bowie  
Hazel Seligman  
Warren M. Behrend  
Sarah Murray  
Louise Corcoran  
Carolyn Sundell  
Anne Tinley  
Lillian Neilson  
Janis Seale  
Edith Reeve  
Marion Humphries  
Carolyn Drennan  
Frances V. Miller

## ROLL OF HONOR

A list of those whose contributions were deserving of high praise:

## PROSE

Barbara J.  
Von Canon  
M. Willard Messler  
Ethel Fitzpatrick  
Alice D. Love  
Mabel Hartleb  
Lillian B. Goodhart  
Victoria Cranford  
Ida Hicks  
Hannah J. Cox  
Barbara Simison  
Elaine Pearce  
Florence Bell  
Ruth T. Smith  
Phyllis F. Beckwith  
Marjorie H. Coulter  
Helen F. Hinton  
Elizabeth Hall

Elizabeth Fehrer  
Harriet Marrack  
Beatrice Mitchell  
Fronie Wood  
John A. Donovan  
Barbara Brewer  
Mary H. Stoddard

## DRAWINGS

Margaret Snowe  
Ellen L. Carpenter  
Mary S. Brewster  
Emilie Heilprin  
Constance  
Constable  
Mary W. Hawke  
Eloise White  
Marie Horst  
Dorothy Slayton  
Margaret Buck  
Lydia Spitzer  
Jarrett Y. Chong  
Elinor Kendall  
Aline Wharton  
Dorothy E. Adler  
Elinor Higgins  
Lois A. R. Lord  
Marjorie W. Smith  
Anne O. Porter  
Jacqueline T. Smith  
Irma Foster  
Marquis Lewis  
Lalia B. Simison

## VERSE

Eleanor Blum  
Johanna Hein  
Barbara Morris  
Julia F.  
Van der Veer  
Frieda Dieth  
Polly Oleott  
Doris Sibbald  
Elizabeth Botsford  
Betty Fulton  
Dorothy Bing

## PHOTOGRAPHS

Rafael A. Peyré  
Constance Fleetham  
Barbara Jack  
Virginia Miley  
Alan Buehes  
Vera M. Drake  
L. O. Field  
Dorothea Darrah  
Polly Passmore  
Esther W. Littlefield  
Faith H. Poor  
Louise Evans  
Dick Burlingame  
Frances Coppage  
Dorothy D. Talman

## PUZZLES

Rosalind Howe  
Winifred Stahly  
Robert Eddy  
Harriet Dow  
Janet G. Rutter  
Alma Miller  
Mary Cadwallader  
L. Pucker  
Helen Rodney  
Frances J. Partridge  
Dorothy M. Jones  
John K. Voorhis  
Jane Ristine  
Dorothy Schueller

## WHAT THE LEAGUE IS

THE ST. NICHOLAS LEAGUE is an organization of the readers of the ST. NICHOLAS MAGAZINE.

THE LEAGUE motto is "Live to learn and learn to live."

THE LEAGUE emblem is the "Stars and Stripes."

THE LEAGUE membership button bears the LEAGUE name and emblem.

THE ST. NICHOLAS LEAGUE organized in November, 1899, became immediately popular with earnest and enlightened young folks, and now is widely recognized as one of the great artistic educational factors in the life of American boys and girls.

THE ST. NICHOLAS LEAGUE awards gold and silver badges each month for the best *original* poems, stories, drawings, photographs, puzzles, and puzzle answers.

## PRIZE COMPETITION, No. 270

Competition No. 270 will close June 1. All contributions intended for it must be mailed on or before that date. Prize announcements will be made and the selected contributions published in ST. NICHOLAS for September. Badges sent one month later.

**Verse.** To contain not more than twenty-four lines. Subject, "Over the Hills."

**Prose.** Essay or story of not more than three hundred words. Subject, "A Test of Friendship."

**Photograph.** Any size, mounted or unmounted; no blue prints or negatives. Young photographers need not develop and print their pictures themselves. Subject, "My Most Artistic Photograph."

**Drawing.** India ink, very black writing-ink, or wash. Subject, "Going Away," or "A Heading for September."

**Puzzle.** Must be accompanied by answer in full.

**Puzzle Answers.** Best and neatest complete set of answers to puzzles in this issue of ST. NICHOLAS. Must be addressed to THE RIDDLE-BOX.

No unused contribution can be returned unless it is accompanied by a self-addressed and stamped envelop of proper size to hold the manuscript or picture.

## RULES

ANY reader of ST. NICHOLAS, whether a subscriber or not, is entitled to League membership, and upon application a League badge and leaflet will be sent free. No League member who has reached the age of eighteen years may compete.

Every contribution, of whatever kind, must bear the name, age, and address of the sender and be indorsed as "original" by parent, teacher, or guardian, who must be convinced beyond doubt—and must state in writing—that the contribution is not copied, but wholly the work and idea of the sender.

If prose, the number of words should also be added. These notes must not be on a separate sheet, but on the contribution itself—if manuscript, on the upper margin; if a picture, on the margin or back. Write in ink on one side of the paper only. A contributor may send but one contribution a month—not one of each kind, but one only; this, however, does not include "competitions" in the advertising pages or "Answers to Puzzles."

Address: **The St. Nicholas League,**  
The Century Co.

353 Fourth Avenue, New York.

## THE LETTER-BOX

### PETROPOLIS, BRAZIL.

DEAR ST. NICHOLAS: Although I'm a Brazilian girl I can pass delightful hours with you, for I'm learning English for two years and can read you. I write you this letter for I've got heaps to tell you—how much I enjoy and delight in you, and so, by your printed pages, I've become your friend. Of course, you know nothing about me, but I know you very well and how interesting and absorbing you are. You must have thousands of friends all over the world, like me, for people will love you if they can but read one of your pleasant pages. I live here in Petropolis, a very picturesque and charming summer resort, near Rio de Janeiro, the capital of Brazil. Petropolis is among the mountains of Serra Estrella (Serra Star) and is very agreeable and cool; though it is very near Rio de Janeiro, the difference of climate is great. It is the place where the people who live in "Rio" pass the summer, and it is much appreciated by the foreigners for its natural beauty and the beautiful flowers that grow here, of which the most abundant is called "*Hortensia*" (Hydrangea), that add to the attractiveness of the town. Brazil's climate is quite different from Europe's for it's hot, though in the south it is moderate and it freezes. Rio is very hot, and in summer quite awful, but Petropolis is cool, and rather cold in winter for it is on the top of the mountain. Rio de Janeiro is just below, and its distance by railroad is of an hour and forty minutes.

Rio de Janeiro is very beautiful and its harbor is just enormous. It could contain all the fleets in the world put together. I want very much to go to New York and know this beautiful and advanced city and all America (for I know yours is one of the richest nations of the world), and to know you better, dear ST. NICHOLAS. But as I can't go yet just, I send my respectful love and good wishes.

From your most appreciative reader and loving subscriber,

ENA M. CASTELLO BRANEO (AGE 15).

### DEERFIELD, N. Y.

DEAR ST. NICHOLAS: I am so happy! I have earned the privilege of having you visit me for another whole year. At a contest at Grant's Book Shop, in Utica, I won fourth prize, which was *you*. Am I not lucky?

I have taken you for one year and could not get along without you now. I certainly enjoy your stories and read every one, besides the ST. NICHOLAS LEAGUE, to which I belong.

Your happy reader,

MARIE RUBEN.

### ALAMEDA, CALIF.

DEAR ST. NICHOLAS: In your November number of 1920 there was an article on the "butterfly tree" on Point Pinos, near Pacific Grove, California. I lived in Pacific Grove for several years and saw the butterfly tree many times. Strange as it may seem, many of the residents of the town have never visited it. When there are no butterflies there, the tree is just like any other Monterey pine. When there are, it looks entirely different, although often one does not notice it from the road, because the color of the butterfly is very

much like that of the trunk of the tree. There are butterflies on the ground about it and clinging to the bushes. They seem stupefied and unable to fly. I have often picked a blade of grass with a butterfly on it, and tried to take it home. The butterfly either fluttered off a few feet, or remained clinging to the grass. They always fall off before you get far, but make no effort to fly. I agree with the author of the article when he says, "Wonders will never cease!"

Your devoted reader,

MARY H. EDWARDS.

### THOMASVILLE, N. C.

DEAR ST. NICHOLAS: I have just started taking you, so of course I don't know much about you. But this week, when I got the first copy, I nearly had a fit, I was so pleased.

I've been taking a children's magazine, but after five or six years it got too babyish for me, so I changed to you, and I'll tell you I certainly did miss something, for there I was taking a mere baby paper, when I could have been taking you.

I like "The Turner Twins" just fine, although it was the seventh chapter when I began and—well, I just love the whole thing.

I want to be a Roll-of-Honor girl and win a silver or gold badge, and I'm going to try hard for them.

From a new and loving reader,

CATHARINE CAMPBELL LAMBETH (AGE 9).

### KALAMAZOO, MICH.

DEAR ST. NICHOLAS: I have only taken you this winter, but now I don't see, how I ever stood it without you. You help me in school, besides giving me long hours of pleasure. For instance, in geography we are studying the Yukon and Mackenzie rivers. We get special A's if we bring in a report. When I got you for February, you had such a lovely story about a man that explored the Yukon so I took you to school and got a special A. I want you to remember that I am one of the hundreds that love and enjoy you.

Yours truly,

HILDA MABEL APTELL (AGE 10).

### SANTA FÉ, N. M.

DEAR ST. NICHOLAS: I have only taken you for a few months, but it seems like years. I don't know how I ever got along without you. I am very much interested in "The Inca Emerald" and "The Blue Envelop."

The town I live in is very interesting. It is the oldest in the United States. There is an old church here which was built about the middle of the sixteenth century—sometime between 1550 and 1560. There is also an old house which was built about the same time.

There is an old building here which is called the Palace of the Governor. It has had Indian, Spanish, Mexican, and American governors in it. It was built by De Vargas when he first came into this country. De Vargas himself is buried under the altar of the old San Miguel Church. In this old palace, Lew Wallace wrote his famous story "Ben Hur." The old chair and lap-board which he used are still there. The palace is now used as a museum.



There are many interesting Indian villages, or pueblos, about here, and it is a common sight to see Indians in bright-colored blankets and heavy silver ornaments strolling about the streets. Most of the Indians around here, men and women alike, cut their hair short at the sides and leave it long in the back, twisting it into a little roll and winding bright-colored string or rags about it.

Another thing that may be seen on our streets are the little burros that go trotting around with loads of wood on their back.

Thanking you very much for the many interesting times you have given me, I remain your faithful reader,

SARA OSBORN (AGE 12).

GORDON, TASMANIA.

DEAR ST. NICHOLAS: I am writing to say that I think you are the loveliest magazine in all the world. My kind aunty has sent you to me for eight years already, and many and many a happy hour with you I have spent. You have opened up wonderful new worlds and given me life-lasting friends. My sister enjoys you, too. Of course, we don't agree with *all* you say about America being the best land on earth, because we are British-Scotch, really, and we love Tasmania with all our hearts. But this is natural. Tasmania is such a pleasant place. Now I must close,

I remain your loving reader,

LILLIAS MITCHELL (AGE 15).

DOMINO, CALIF.

DEAR ST. NICHOLAS: We live in Antelope Valley, in Kern County, California. All around our school there is grease-wood and sage-brush. We have a lot of coyotes and rabbits. Last week we went hunting on a burro and found eighteen rabbits. They were caught in the snow. The snow has been eighteen inches deep. In some places between Los Angeles and Bakersfield, the snow was so deep that aeroplanes had to come with food for the people.

Your new friend,

JAMES ROSS (AGE 11).

PITTSBURGH, PA.

DEAR ST. NICHOLAS: You have been a welcome visitor at my home for five years, and I hope you will keep on coming for the next five years and more. It is needless to say which of your stories I like best, because each one occupies the same place in my heart.

I was sick yesterday, and I read every back number of you I could find.

Perhaps you would like to hear about a visit I made to the steel-mills.

I went into the furnace building, and a man lent me a pair of blue spectacles to look into the furnaces. I did so, and was surprised at the molten ore. It was not as I thought it was, but looked like boiling milk.

He then showed me the workman pouring the metal into the ingot molds, and it beats Fourth of July ten times. The sparks and noise were terrible.

Then, in the roller-room, the hot ingots were dumped onto rollers, which made them into steel rails. I was standing by one of the rollers, when suddenly a red-hot rail came out of the roller back

of me; and you can believe me, I vacated pretty quick.

Wishing you many years of happy existence, I am,

Your interested reader,

THOMAS ORCHARD (AGE 11).

TOKYO, JAPAN.

DEAR ST. NICHOLAS: I send this letter beyond the Pacific Ocean—I am a Japanese. Several days ago I found you at the Maruzen's, and, charmed with your beautiful cover, I took you in hand and read two or three pages. The more I read, the more the interest increases. And when I went out the store, you were firmly under my arms. On arriving home, I read you with great and deep interest, though there were many difficult words for me, because I learned English with myself, and only few years has passed since I began it. (So I fear you will hardly understand my *broken* English.) And yet you were so charming that I have never departed from you since that time. Among many interesting stories I like "The Kangaroo" best. I determined to read you every month from now, although I can not order you directly.

Your very-loving reader,

YASUTARO KOBAYASHI (AGE 14).

MCCOOL JUNCTION, NEBR.

DEAR ST. NICHOLAS: I've taken you for nearly four years, and though we take a great many magazines, I've never enjoyed any as I do you. After I've finished reading you, it seems quite a while from the beginning of one month to the beginning of the next.

I live in one of the "Great Plains" States—Nebraska. I spent most of last summer in Utah—living out, camping, and fishing. Though I'm in love with the plains, I thought the pine-covered hills and snow-topped mountain-peaks, blue in the distance, were just wonderful. We visited other towns besides the one where we were. One day we went thirty-five miles to another town to a ball-game, and then found out it was at another place on up the mountain. We ate dinner and went back home and arrived there in time for our own ball-game and celebration. We had a good ride even though we did go seventy miles just for dinner.

I read THE WATCH TOWER every month, and I think "The Blue Envelop," "The Turner Twins" and "The Hill of Adventure" are just fine—especially "The Turner Twins."

With best wishes,

DOROTHY KNAPP (AGE 16).

BONNING, CALIF.

DEAR ST. NICHOLAS: My brother Homer took you last year—maybe you remember sending it to him. When Mama said we had better stop the ST. NICHOLAS, we all said, "No," so we put our money together and sent it in for another year.

Maybe you would like to hear the story of when we got lost. Well, we were out playing one day when we ran down a cañon. I must say, before I go on, that we live in the mountains. Well, we got off the trail, anyhow. We climbed over and under the brush and could not find our way out. By and by we heard Daddy. Then we knew we would not have to stay out all night.

Yours truly,

MARCELLA POUNALL (AGE 10).



# The RIDDLE-BOX

## ANSWERS TO PUZZLES IN THE APRIL NUMBER

**A CROSS.** From 1 to 2, The ST. NICHOLAS; 3 to 4, all should read. Cross-words: 1. Tuna. 2. Heel. 3. Evil. 4. Possession. 5. Buttonhole. 6. Round-robin. 7. Undisputed. 8. Call. 9. Heed. 10. Over. 11. Line. 12. Aria. 13. Skid. **ANAGRAM WORD-SQUARE.** 1. Bane. 2. Amid. 3. Nine. 4. Eden.

**RIDDLE. C-O-M-I-C.**  
**TRANSPPOSITIONS.** Roosevelt. 1. Pear, reap. 2. Rove, over. 3. Peon, open. 4. Vase, save. 5. Bone, ebon. 6. Live, vile. 7. Mite, emit. 8. Nile, line. 9. Note, tone.

**DIAMOND.** 1. S. 2. Sad. 3. Sabre. 4. Dry. 5. E.

**ILLUSTRATED ZIGZAG.** Shakespear. 1. Siphon. 2. Church. 3. Grapes. 4. Locket. 5. Bushel. 6. Skates. 7. Stamps. 8. Screen. 9. Orange. 10. Archer. 11. Eleven.

**NOVEL DOUBLE ACROSTIC.** Initials, William Shakespeare; fourth row, Antony and Cleopatra. Cross-words: 1. Wheat. 2. Inane. 3. Loath. 4. Labor. 5. Inane. 6. Andy's. 7.

Macaw. 8. Seine. 9. Herds. 10. Alice. 11. Knoll. 12. Elves. 13. Spoon. 14. Peeps. 15. Essay. 16. Abate. 17. Rears. 18. Equal.

**A LITERARY ACROSTIC.** Initials, Alfred Tennyson; from 1 to 12, The Holy Grail; 13 to 30, Launcelot and Elaine; 31 to 47, The Coming of Arthur; 48 to 63, Gareth and Lynette. Cross-words: 1. Augment. 2. Lightly. 3. Forlorn. 4. Radiant. 5. Elegant. 6. Discern. 7. Thought. 8. Edifice. 9. Neutral. 10. Nullify. 11. Yucatan. 12. Sheathe. 13. Obscure. 14. Notions.

**HEART PUZZLE.** Downward: 1. T. 2. Arc. 3. Tart. 4. Iris. 5. Atop. 6. Nor. 7. R.

**LAMP PUZZLE.** Centrals, William Shakespeare. Cross-words: 1. Awe. 2. Bid. 3. Valid. 4. Ballast. 5. Sentiment. 6. Plantagenet. 7. Fundamental. 8. Permissible. 9. Shy. 10. Finance. 11. Markets. 12. Hideos. 13. Asp. 14. Ape. 15. Yew. 16. Shark. 17. Startle. 18. Blameless.

**TO OUR PUZZLERS:** To be acknowledged in the magazine, answers must be mailed not later than MAY 27 and should be addressed to ST. NICHOLAS RIDDLE-BOX, care of THE CENTURY CO., 353 Fourth Avenue, New York City, N. Y. Solvers wishing to compete for prizes must comply with the LEAGUE rules (see page 780) and give answers in full, following the plan of those printed above.

ANSWERS TO ALL THE PUZZLES IN THE FEBRUARY NUMBER were duly received from Susan E. Lyman—Priscilla Manning—Kemper Hall Chapter—Helen H. McIver.

ANSWERS TO PUZZLES IN THE FEBRUARY NUMBER were duly received from John R. Hopkins, 9—Mary Watts, 9—Roman Kopec, 9—Rosalind Howe, 9—"Three R's," 9—Arleen Millsap, 9—"The Days," 9—Sarah Light, 9—June M. Hinman, 9—John F. Davis, 9—Vera A. Skillman, 9—Richard H. Wilsey, 9—St. Anna's Girls, 9—"Four J's," 9—Anne W. Ames, 9—Carlan S. Messler, 8—Edna Lehre, 8—Edith Kennedy, 8—Blanche L. Cunningham, 8—Judith Haight, 7—Hortense A. Doyle, 7—Corinne Clayton, 7—Elizabeth Tong, 7—Dorothy N. Teulon, 7—Mary A. Hard, 6—"Blackie," 5—Elizabeth C. Hale, 5—M. Willard Messler, 5—"St. N. Club," 5—Janet Roscnwald, 5—"Me," 4—Kingsley Kahler, 4—Matthew Hale, Jr., 4—Elizabeth S. Livermore, 4—Betty Foote, 3—"Kennett Sq.," 3—M. D. W. and C. L. B., 3—Muriel Strugnell, 3—Harriet Loutrel, 3—D. Airey, 2—P. Remington, 2—M. Murray, 2—E. Mapes, 2—D. Embree, 2—P. Winkler, 2—M. Stimson, 2—L. Cotty, 2—One puzzle: A. S.—S. G. B.—P. S.—M. K.—E. N.—L. W.—D. W.—M. L. C.—E. J. B.—F. B.—I. B.—G. M. B.—S. F.—M. L.—C. G.—L. S.—E. H.—J. C. W.—M. I. R.—P. H. P.—S. P.

### CHARADE

(Silver Badge, ST. NICHOLAS LEAGUE Competition)

My first was first in the time of men;  
 My last is small and was ancient then;  
 My whole is hard and was ancient when  
 My last was really new.

HARRY BOWEN BRAINERD (age 14).

### DIAMONDS

I. 1. In maybe. 2. A French city not far from Spain. 3. A tree. 4. A city on the Danube. 5. In maybe.

II. 1. In maybe. 2. A beverage. 3. A tree. 4. To perform. 5. In perhaps.

III. 1. In maybe. 2. To imitate. 3. A tree. 4. A measure of length. 5. In perhaps.

IV. 1. In perhaps. 2. A vegetable. 3. A tree. 4. A unit. 5. In perhaps.

BETTY DERING (age 11), League Member.

### ZIGZAG

All the words described contain the same number of letters. When rightly guessed and written one below another, the zigzag—beginning with the upper, left-hand letter and ending with the lower, left-hand letter—will spell the name of a famous old author.

CROSS-WORDS: 1. Melody. 2. Lubricated. 3. An African. 4. To play monotonously on a

stringed instrument. 5. A weapon. 6. A large bird. 7. Fervor. 8. Lawful. 9. A Hebrew measure of length. 10. A fruit. 11. A large boat for carrying freight. 12. A fruit. 13. A bone of the leg. 14. A wading bird. 15. The language of the ancient Romans. 16. Part of a flower. 17. Scanty.

GEORGE E. UTTERBACK (age 14), League Member.

### CHANGED FINALS

I am a word meaning a tablet. Change my last letter only, and I become in turn a comrade, a utensil, a step, a stroke, a French city, a foot, and wages.

BETTY HUTCHINSON (age 13), League Member.

### CROSS-WORD ENIGMA

My first is in Maine, but not in Nevada;  
 My second, in Nevada, but not in Mississippi;  
 My third is in Mississippi, but not in Florida;  
 My fourth is in Florida, but not in Arkansas;  
 My fifth is in Arkansas, but not in Idaho;  
 My sixth is in Idaho, but not in Montana;  
 My seventh, in Montana, but not in Illinois;  
 My eighth is in Illinois, but not in Dakota;  
 My ninth is in Dakota, but not in Utah;  
 My tenth is in Utah, but not in New York;  
 My eleventh is in New York but not in Oregon.

My whole is a May holiday.  
 ELIZABETH TAYLOR (age 16), League Member.



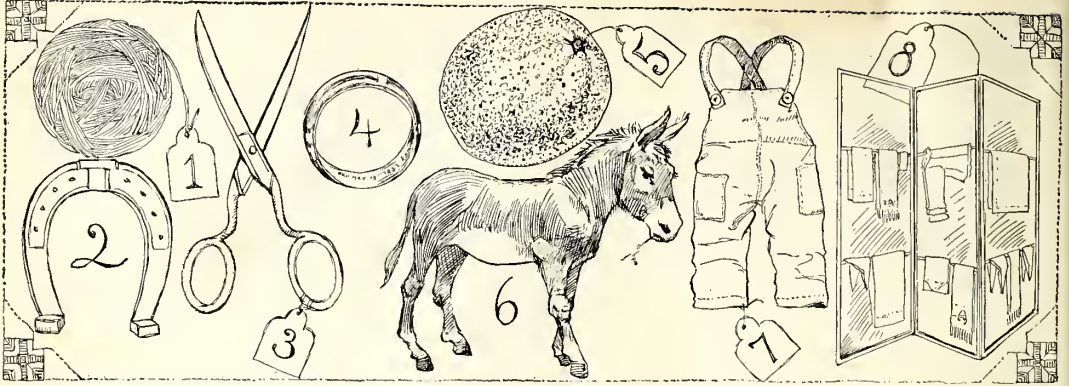

### PICTURED ANSWERS

A number of objects are shown in the above picture. Among them may be found the answers to the four following riddles:

- I. When new, it 's dull; when old, it 's bright;  
It 's worn, and fits the wearer tight,  
And is n't taken off at night,
- II. A steed there is well known to you  
That never yet wore saddle or shoe,  
Nor ever dragged or carried a load  
Of any kind along a road.
- III. Their union means division where aforetime  
there was none;  
Their division 's no undoing of the thing that  
they have done;  
And they 're hard upon each other, yet the  
two are reckoned one.
- IV. In shape, a model of the globe;  
It wears a fiery-colored robe;  
Its sections closely packed within,  
And fenced about with skin on skin.

RICHARD PHILLIPS.

### CENTRAL ACROSTIC

All the words described contain the same number of letters. When rightly guessed and written one below the other, the central letters will spell the name of the flagship at a famous naval battle.

CROSS-WORDS: 1. A sheltered place. 2. Vanity. 3. Often on the breakfast table. 4. At a more distant time. 5. A necessity in a kitchen. 6. A social gathering. 7. A stratum.

EDGAR A. SMITH (age 14), *League Member*.

### BROKEN NAMES

The names of certain vegetables have been broken up into syllables. Properly grouped, twelve names will appear.

As, on, spin, ar, car, gus, ti, ach, nip, a, cab, rad, to, let, choke, rhu, on, tur, i, pars, rot, bage, par, ma, tuce, barb, ish, to, nip.

RUTH WILLISON (age 14), *League Member*.

### A BIRD PUZZLE

The names of all the birds described contain the same number of letters. When rightly guessed and written one below another, the eight initial letters will spell the title of a book by John Burroughs.

CROSS-WORDS: 1. A large, web-footed bird. 2. Young eagles. 3. A bird of gorgeous plumage. 4. A South American passerine bird. 5. A bird whose note sometimes resembles a cat's mew. 6.

A bright-colored singing bird. 7. A large, two-toed bird which can not fly. 8. A South American barbet or puff-bird.

HELEN KNOTHE (age 12), *League Member*.

### DOUBLE DIAGONALS

(*Silver Badge*, ST. NICHOLAS LEAGUE Competition)

All of the words described contain the same number of letters. When rightly guessed and written one below another, the diagonal beginning at the upper, left-hand letter and ending with the lower, left-hand letter, and the diagonal beginning with the upper, right-hand letter and ending with the lower, right-hand letter will each name a famous poet.

CROSS-WORDS: 1. A season. 2. The scene of the battle of Pittsburg Landing. 3. To empower. 4. Occurring every seven days. 5. Unmeaning talk. 6. Fierce animals. 7. Sudden. 8. Most loyal. 9. Undersized persons. 10. The French word for silver. 11. Morals.

CATHERINE WATSON (age 14).

### PI

Won grins het loadwond doul dan glon,  
Het catdines kates a veilrole ehu,  
Dan wronded ni derony givlin bul'e  
Het karl scombee a slightness gons.

FRANCES JAY (age 13), *League Member*.

### A NOVELIST'S PUZZLE

(*Gold Badge*, ST. NICHOLAS LEAGUE Competition)

* 16	48	64	13	.	CROSS-WORDS: 1. Adven-
* 39	1	67	.	24	turous. 2. To rise. 3. One
* 33	11	51	.	.	of the pirate crews of North-
* 25	18	45	60	.	men. 4. To kindle. 5. To
* .	2	58	32	53	dissuade. 6. A Chinese labo-
* 41	27	56	9	.	rorer. 7. To turn toward. 8.
* .	46	12	.	65	To appease. 9. A common
* 3	63	36	59	21	tree. 10. Not refined. 11.
* 62	42	28	55	22	A thief. 12. A violin. 13.
* 19	17	54	40	38	Flows out. 14. To shun.
* 43	15	20	.	4	15. Deepest. 16. Melodious.
* 66	8	29	44	57	When these words have
* 14	35	31	6	52	been rightly guessed, the ini-
* 68	10	.	47	61	tial letters (indicated by
* 34	50	26	7	49	stars) will spell a famous
* 23	5	30	.	37	novel. The letters indicated

by the figures from 1 to 14 will spell the writer's name; the letters indicated by the figures from 15 to 26, from 27 to 42, from 43 to 53, and from 54 to 68 will spell the titles of four other novels by the same writer.

MARGARET PECK (age 16).



TAKE the first letter in the name of each of the things pictured here. What do the letters thus selected spell?

Write your answer on the coupon below, mail it to us, and we will send you, free, a generous trial tube of Colgate's Ribbon Dental Cream.

Colgate's is recommended by more dentists than any other dentifrice. It cleans teeth the right way—*safely and thoroughly.*

The delicious flavor makes its use a treat, not a task.

COLGATE & CO.  
Dept. 60  
199 Fulton Street, New York

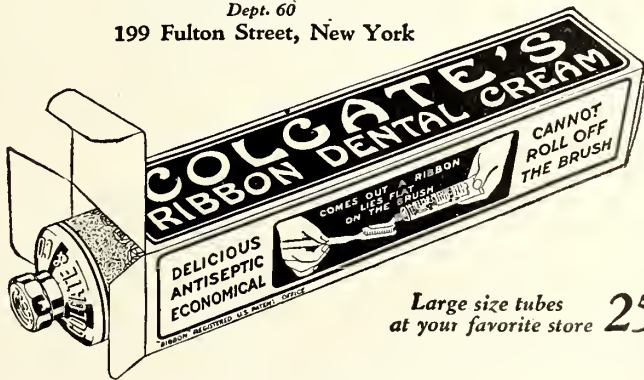

Large size tubes  
at your favorite store 25¢

COLGATE & CO., Dept. 60, 199 Fulton Street, New York

The first letters of the names of the things shown in the panel above spell .....

(My name is) .....

(My address is) .....

.....



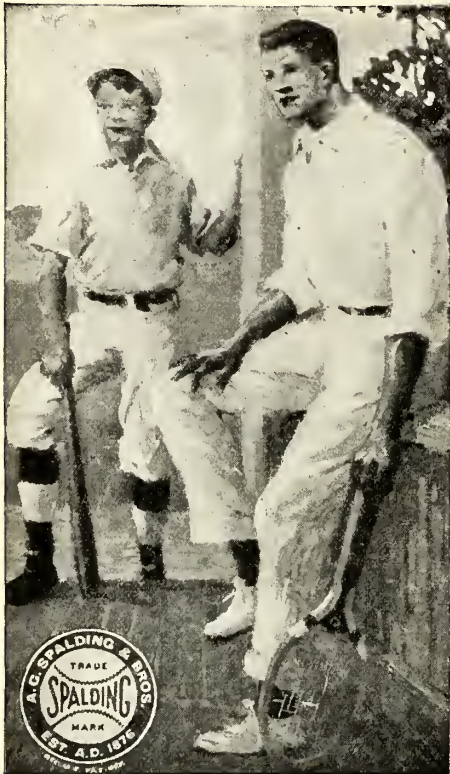

“S” stands for  
 “Sportsmanship”  
 as well as  
 “Spalding.”

There is no  
 substitute for  
 either. *Catalogue of athletic  
 goods mailed free.*

*A. G. Spalding & Bros.*

New York Chicago San Francisco  
 126 Nassau St. 211 South State St. 156 Geary St.

And all large cities. Dealers everywhere.

- Spalding Lawn Tennis Annual. . . . . 25 cents
- "The Kid"—A Tennis Lesson, By Wm. T. Tilden, 2d. . . . . 25 cents
- Strokes and Science of Lawn Tennis. . . . . 25 cents
- Spalding Official Base Ball Guide. . . . . 25 cents
- How to Pitch. . . . . 25 cents
- How to Bat. . . . . 25 cents



THE joy of all outdoors is yours in an "Old Town Canoe."  
 For "Old Towns" are the easiest canoes to paddle. They  
 are the fastest and steadiest canoes made—the lightest and  
 strongest canoes you can buy—and the lowest priced. "Old  
 Towns" last for years. \$54 Up from dealer or factory. Write  
 for new catalog showing all models in colors. Free.

OLD TOWN CANOE CO.

245 Fourth Street

Old Town, Maine, U. S. A.

*"Old Town Canoes"*

**ROCHE'S** WAGON **EMBRICATION**  
 RELIEVES SAFELY AND PROMPTLY

**GROUP**  
 OR  
**WHOOPIING COUGH**

Also wonderfully effective  
 in Bronchitis, Lumbago  
 and Rheumatism.  
 All druggists or

**W. EDWARDS & SON** **E. FOUGERA & CO.**  
 London, England 90-92 Beekman St. N. Y.

**Try before you Buy**

Your choice of 44 styles, colors and sizes in  
 the famous *Ranger* line. Write for our marvelous  
 prices and terms. Shipped on approval and **30**  
**DAYS' FREE TRIAL, express prepaid.**  
**12 Months to Pay**—You can get immediate posses-  
 sion and use of any *Ranger* Bi-  
 cycle on our liberal Easy Payment plan.  
**Tires**—Best quality at factory prices. *express paid.*  
 Lamps, wheels, horns, equipment  
 and repairs at unusually low prices.



**Mead Cycle Company**  
 Dept. W15 Chicago

Write today for free  
*Ranger* Catalog, fac-  
 tory prices and mar-  
 velous easy payment terms

**LIVE  
 OUTDOORS!**

WE believe so thoroughly in the  
 great tonic of sunshine and  
 fresh air, that we take this opportu-  
 nity to urge upon parents the use of  
 St. Nicholas Camp Department—  
 the Gateway to a summer in the  
 open for boys and girls.

Inquiries receive our most careful  
 attention. We try to fit camps to  
 your individual requirements.

Address

**ST. NICHOLAS CAMP SERVICE DEPARTMENT**

St. Nicholas Magazine

353 FOURTH AVENUE, NEW YORK CITY

JUNE, 1922

# ST. NICHOLAS



HAROLD  
NICHOL

THE CENTURY CO

353-FOURTH AVENUE NEW YORK

THE CENTURY

AND

ST. NICHOLAS





# Miniature Cake Free

To Girls Who Like Dainty Toilet Soap

We invite every girl who reads St. Nicholas to send for this cake of famous Palmolive Soap, the soap with a history. It is made from the same palm and olive oils that were discovered 3,000 years ago in ancient Egypt. All classic peoples used these oils for cleansers. Flagons and jars equipped the luxurious marble baths of Egyptians, Greeks and Romans.

These oils came in skins and flasks, by galley and caravan, and users did their own blending. Modern Palmolive is made in gigantic up-to-date factories which work day and night to supply the demand. The oils are imported from overseas in vast quantities.

And while the advance of science hasn't been able to discover finer, more beneficial ingredients, it has perfected the blend until old-time users wouldn't recognize modern Palmolive.

The smooth, creamy Palmolive lather is so mild and soothing that it makes your skin soft and keeps it smooth. If you want a lovely complexion when you

grow up, use Palmolive now for cleansing your face and for bathing.

## *Free to boys, too*

Palmolive should interest every boy because Greek and Roman warriors and athletes used palm and olive oils for cleansing and anointing their bodies. You are using these same historic oils every time you use Palmolive.

## *Send your name*

Write your name and address on a post card and mail it to the Palmolive Company, Milwaukee, U. S. A., and we will send you the free cake of Palmolive by return mail. Let your mother try it too, and you will find she likes it so well that she will always keep you supplied with Palmolive.



THE  
PALMOLIVE  
COMPANY  
Dept. B-255  
Milwaukee, U. S. A.

THE  
PALMOLIVE COMPANY  
OF CANADA, *Limited*,  
TORONTO, ONT.

*Also manufacturers of a  
complete line of toilet  
articles*

# Beech-Nut Jams and Jellies

## JAMS

Blackberry  
Damson Plum  
Loganberry  
Peach  
Red Raspberry  
Strawberry

## JELLIES

Apple  
(Spitzenberg)  
Black Currant  
Crab Apple  
Grape  
Quince  
Red Currant

## MARMALADES

Orange  
Grape Fruit



© 1920, B-N. P. Co.

**B**UTTER the slice thick, and then spread Beech-Nut Jam or Jelly. Fellers, there's nothing like it! All the sweets you want, without breaking training. It's *good* for you!

Beech-Nut Jams and Jellies have that good old-fashioned home-made flavor—the real flavor of the fruit! And why not? They're made of just pure fruit and sugar—put up in jars when the fruit's the ripest.

You always know the Beech-Nut flavor because it's *real!* Remind mother to ask for Beech-Nut.



**BEECH-NUT PACKING COMPANY**

Canajoharie

New York



# CONTENTS OF ST. NICHOLAS FOR JUNE, 1922

Frontispiece: "Please!—If you will let me, I think I can help!" Drawn by W. P. Couse

**Jimmy Dodd Plays Mixed Doubles.** Story.....Cornelius Brett Boocock ..... 787  
 Illustrated by C. M. Relyea

**The Hollyhock Fairy.** Verse.....M. D. Cole ..... 793

**The Proper Mixture.** Story. Illustrated by Donald Teague.....Elizabeth Price ..... 794

**My Trees.** Verse.....Annie Johnson Flint ..... 798

**Over the Precipice.** Story. Illustrated by George Varian.....Louis Allen ..... 799

**Warning to All Fairies.** Verse. Illustrated by Marion T. Justice.....Hamilton Fish Armstrong ..... 804

**The Mystery at Number Six.** Serial Story.....Augusta Huiell Seaman..... 805  
 Illustrated by W. P. Couse

**Limericks from Lyme: The Steeple Clock—The Garden.** Verse.....Lucy A. K. Adee..... 812  
 Illustrations from photographs

**The Great Balloon Flight.** Sketch. Illustrations from photographs.....Ralph Upson ..... 813

**The White-Throated Sparrow.** Verse.....Eleanore Myers Jewett..... 819

**The Hill of Adventure.** Serial Story.....Adair Aldon ..... 820  
 Illustrated by J. Clinton Shepherd

**The Summer World.** Verse.....Mrs. Schuyler Van Rensselaer ..... 826

**"The Rose."** Picture. Painted by Lydia Field Emmet..... 827

**The Inca Emerald.** Serial Story. Illustrated by Charles Livingston Bull.....Samuel Scoville, Jr. .... 828

**Wind Chantey.** Verse.....Helen Coale Crew ..... 835

**A Flame That Will Burn Under Water.** Sketch.....Robert G. Skerrett..... 836  
 Illustrations from photographs

**Between Two Deaths.** Sketch. Illustrations from photographs.....M. V. Simko ..... 841

**Mr. Jay.** Verse.....Clinton Scollard ..... 843

**The Turner Twins.** Serial Story. Illustrated by C. M. Relyea.....Ralph Henry Barbour ..... 844

**Fish Culture.** Verse. Illustrated.....John Richards ..... 852

**The Undoing of Morning Glory Adolphus.** Story.....N. Margaret Campbell..... 853  
 Illustrated by Harold Sichel

**The Workshop of the Mind.** Sketch.....Hallam Hawksworth ..... 856  
 Illustrated by Enos B. Comstock and from print and photograph

**Sunlight in the Woods.** Story. Illustrated by Dudley Gloyne Summers.....Comfort Gilder..... 863

**The Tardy Scholar.** Verse. Illustrated by Mary P. Ludlum.....Ellen Manly ..... 867

**The Blue Envelop.** Serial Story (Conclusion).....Roy J. Snell ..... 868  
 Illustrated by Sarah K. Smith

**The Watch Tower.** A Review of Current Events. Illustrated.....Edward N. Teall..... 875

**Nature and Science for Young Folk.** Illustrated..... 880  
 Guiding Air-craft into Port at Night and in Foggy Weather (M. Tevis)—  
 Merula (W. W. Arnold)—Electrical Device Draws Fish-worms from  
 the Soil (George F. Paul)

**For Very Little Folk:** Illustrated by Edith Ballinger Price

**An Adventure**.....H. C. Southwick ..... 884

**The Drydish Dragon—The Red Balloon.** Verse.....Edith Ballinger Price ..... 885

**The St. Nicholas League.** With Awards of Prizes for Stories, Poems,  
 Drawings, Photographs, and Puzzles. Illustrated..... 886

**The Letter-Box**..... 894

**The Riddle-Box**..... 895

**The St. Nicholas Stamp Page.** Conducted by Samuel R. Simmons.....Advertising Pages

 *The Century Co. and its editors receive manuscripts and art material, submitted for publication, only on the understanding that they shall not be responsible for loss or injury thereto while in their possession or in transit. Copies of manuscripts should be retained by the authors.*

In the United States, the price of ST. NICHOLAS MAGAZINE is \$4.00 a year in advance, or 35 cents a single copy; the price of a yearly subscription to a Canadian address is \$4.35. The price of a yearly subscription to a foreign address is \$4.60. We request that remittances be by money-order, bank check, draft, or registered letter. The Century Co. reserves the right to suspend any subscription taken contrary to its selling terms, and to refund the unexpired credit. PUBLISHED MONTHLY.

The half-yearly parts of ST. NICHOLAS end with the October and April numbers respectively, and the red cloth covers are ready with the issue of these numbers; price \$1.00 by mail, postpaid; the two covers for the complete volume, \$2.00. We bind and furnish covers for \$2.00 per part, or \$4.00 for the complete volume. (Carriage extra.) All copies of this magazine which are to be bound must be sent to our New York office. In sending the numbers to us, they should be distinctly marked with owner's name. Bound volumes are not exchanged for numbers.

All subscriptions for, and all business matters in connection with, ST. NICHOLAS MAGAZINE should be addressed to

**THE CENTURY CO.**

Publication and Circulation Office, Concord, N. H.

Editorial and Advertising Offices, 353 Fourth Ave., New York, N. Y.

W. MORGAN SHUSTER, *President*  
 DON M. PARKER, *Secretary*

GEORGE L. WHEELOCK, *Treasurer*  
 JAMES ABBOTT, *Ass't Treasurer*

**BOARD OF TRUSTEES**

VOL. XLIX.

GEORGE INNESS, JR.

GEORGE H. HAZEN, *Chairman*

W. MORGAN SHUSTER

No. 8

(Copyright, 1922, by The Century Co.)

(Title Registered U. S. Pat. Off.)

(Printed in U. S. A., and Entered as Second Class Matter, September 4, 1920, at the United States Post Office, Concord, N. H., under the Act of March 3, 1879. Entered at the Post Office Department, Ottawa, Canada.)

## The Two Famous O'Brien Travel Books

# MYSTIC ISLES OF THE SOUTH SEAS

By FREDERICK O'BRIEN

ONCE more this author has captured between book covers the colorful witchery of the far South Seas. In this new book he makes the delighted reader see and feel the best known of the French Pacific Islands — beautiful, perfumed Tahiti. But, like his amazingly successful "White Shadows in the South Seas," the new volume is more than a marvelous travel book; it is also humor and romance with the narrative drive, the lyrical phrase and the dramatic suspense of a masterpiece of fiction.

Not to have read "Mystic Isles of the South Seas" is to have missed one of the most refreshing experiences of recent years. *The New York Times* says: "O'Brien is unique among the vast numbers of travel writers of the day because of his charm, his insouciance of description, his evident enthusiasm."

*The New York Evening Post* says: "Mr. O'Brien's book is not mere description and glamor . . . he presents in this easy flowing . . . narrative of life with a nature people a new defense of the primitive in man."



*Illustrated. Price \$5.00*



# WHITE SHADOWS IN THE SOUTH SEAS

By FREDERICK O'BRIEN

THIS is that amazing book that set a fashion. It is the most quoted travel book of a generation. Though published over three years ago, it remains one of the seven or eight best selling non-fiction books throughout the whole country. It records, in a prose style of sheer delight, the adventures of the author during a year's residence among the beautiful, simple, friendly cannibals of the Marquesas Islands. Profusely illustrated from unusually attractive photographs.

*Price \$5.00*

At All Bookstores  
Published by

**THE CENTURY CO.**

353 Fourth Avenue  
New York City



# ST. NICHOLAS

## NEXT MONTH AND TO COME

**Drake**

**KATHARINE LEE BATES**

A spirited poem, doing full justice to the heroic deeds of England's great seaman and beautifully decorated with pen-and-ink drawings by W. M. Berger.

**The Pinch Quitter**

**WILLIAM T. TILDEN, 2d**

The world's tennis champion turns his hand to fiction, and scores as easily and as well as he does on the court. A good story, with plenty of tennis sprinkled in. Illustrated by Charles M. Relyea.

**How the Declaration Was First Read**

**GARDNER TEALL**

This is an interesting and authentic article describing the first "Fourth," pointing out that the day the famous document declaring our independence was first read was July 8, 1776. Illustrated with old and unusual prints.

**How the American Army Was Saved by a Dinner and a Song**

**ELLEN D. WANGNER**

When Washington retreated from Manhattan, and took up his stand at Harlem Heights, in 1776, he was pursued by General Howe. But the British general and his staff were so delightfully entertained and detained by a patriot lady, Mrs. Murray of Murray Hill, that Washington had time to save his troops and baggage. Some excellent illustrations by John Walcott Adams.

**Government-Owned Buildings**

**CATHERINE M. TALIAFERRO**

Do you know which owns which? the county, city, state, or nation! This article will set you straight on the question of government ownership of buildings, and will be illustrated with photographs showing several of our best public edifices.

**The Coverlid**

**MARY WELLS**

A brave little Southern girl befriends her neighbor, who is a Northern sympathizer, and her kind and brave deed brings her a great deal of happiness. Handsomely illustrated by Oscar Schmidt.

# “I’m Coming!”

It was a boy who said it as he let the flood force his shanty-boat through the jam to save the two lads on the wreckage; but it was a man in supremely tested courage and firm nerve who came out of the tremendous experiences told in



## DRIFTWOOD

By R. S. Spears

THE BEST STORY OF THE MISSISSIPPI SINCE

### “Huckleberry Finn”

A story for boys and girls of the Mississippi in flood. Full of thrilling adventure and plucky, resourceful, level-headed work of rescue. There is in it something that makes grown-up readers, too, appreciate and praise the book. It is a vivid picture of the river life and river-folk. And behind all the tense, exciting action is a movement that lifts it far above the average, that makes it at the same time an adventure story of the finest and an epic of mighty waters in irresistible flood. A remarkable juvenile; a notable American book; a book to own.

*Illustrated. Price \$2.00*

I  
WANT

.....copies of

## DRIFTWOOD

for which I enclose \$.....

**THE CENTURY CO.**

353 Fourth Avenue

NEW YORK CITY

Name.....

Address.....





# Last Call!



SOON the forests and lakes will again be echoing the shouts and laughter of the myriads of young folk who annually make their pilgrimage to the shrine of Mother Nature. The woods, that have slept in a blanket of snow these long winter months, and are now bursting forth in all the splendor of early spring, will again be the scene of youthful activities and sports of every kind. The glory of these days spent in a summer camp remains with us always. It is an experience not to be forgotten, and lucky are those boys and girls who can still look forward to such a summer.

What opportunities for swimming and canoeing! What a relief on a hot summer afternoon to plunge into the cool, pure, sparkling water and swim out to the float, or engage in a game of water-polo, if you are more actively inclined!

Then there are the canoe trips—overnight excursions, and longer journeys for the older boys; or, if you are a hiking enthusiast, there are many mountain trails and woodland paths to be explored. In the evening, at the end of a day's hard paddle or hike, whichever it may have been, all gather around the camp fire and hungrily watch the sizzling bacon sizzling in the frying pan. After supper, stories, and then bed—sleeping on the soft pine needles, with maybe the moon flooding with silver the lake before us.

There are also all sorts of sports and activities around camp—baseball, volley-ball, tennis, and many other games with which all young campers are familiar.

Are you going to be among those lucky ones who board the train July 1st, to spend two such months in Nature's paradise? If you haven't selected your camp yet, you are sure to find one to suit you in the following section. Cut out the coupon below, send it to our Camp Bureau, and we shall be glad to help you in any way possible.



S.N. 6-22

ST. NICHOLAS CAMP SERVICE DEPARTMENT  
353 Fourth Avenue, New York

Please have information about camps sent me.

Name.....

Address.....

Parent's Signature.....

My age.....

Location of camp.....

Large or small camp.....

Approximate fee desired.....

Name of camp previously attended.....

Remarks.....

# SUMMER CAMPS FOR GIRLS



## Camp Teconnet

The Island Camp for Girls

CHINA, MAINE

Regular camp activities, including land and water sports, overnight trips, and horse-back riding. For booklet, address

Mrs. CHARLES F. TOWNE

122 Woodland Park, Auburndale, Mass.

CONNECTICUT.

### CAMP NEHANTIC FOR GIRLS

A salt water camp. Sea shore and country combined. Bathing, fishing, crabbing, land and water sports. Experienced physical training director in charge. \$190.00. Booklet. Mr. and Mrs. HARRY DAVISON, 5333 Rising Sun Ave., Philadelphia, Pa.

NEW YORK, Middle Island, Long Island.

### CAMP SEEWANAKAH

A girls' camp on Long Island, two hours from New York by motor. All regular crafts and sports. July first to end of August. Two hundred dollars the season.

MISS G. C. FREEMAN, 195 Barclay Street, Flushing, N. Y.



# ALOHA

Camps for Girls Fairlee, Vermont

Three Distinct  
Camps

Ages: 7-13  
14-17 17-30



Aquaplaning

18th Season. All sports. Horseback riding. Our aim — a vigorous body, alert mind, and strong character. 2,000 girls have been in camp and not a single serious accident. Aloha Camp for Boys under same management. For booklets, address

MRS. E. L. GULICK

214 Addington Road

Brookline, Mass.



## Camp Cowasset

North Falmouth, Mass., on Buzzards Bay, Cape Cod. The Seashore Camp for Girls. Senior and Junior camps.

**Seniors:** Canoe and boat trips, use of fine saddle horses and best instruction without extra charge. Pageant, Water Carnival, tennis and games, gypsy trips, handicrafts. First Aid and Camp Paper.

**Juniors:** Salt water sports, careful oversight, *free riding and instruction*, overnight hikes, nature study, tennis, basket-ball, baseball, volley-ball, dramatized stories, good food, good fun and good care.

Address MISS BEATRICE A. HUNT, Plymouth St. Holbrook, Mass.





## Camp Cotuit

For girls of 9 to 20. Beautiful location on Cape Cod with fresh and salt water swimming under expert instructors. Healthful and body building as well as enjoyable. Tennis, canoeing, all field sports and games. Horseback riding under the careful supervision of Mr. W. A. Laing, of the Halcyon Hall Riding Academy. Tutoring if desired. Limited enrollment. Catalog. Address

**Miss Emma L. Schumacker**  
Care Miss Beard's School  
Orange, N. J.



## CAMP AREY

On lovely Lake Keuka, N. Y. (9th Season). A camp unique in its life, spirit and associations. Unusual record of health and development; restricted enrollment, resident graduate nurse. Track athletics, baseball, basket-ball, hockey, crews, horseback riding, all water sports carefully supervised by expert instructors, hikes, camping trips, dramatics, singing and dancing, camp paper, cercle français.

MRS. A. C. FONTAINE, Roslyn Heights, N. Y.

LONG ISLAND, Bellport.

## CAMP GRANGE

Under the direction of experienced Directress and Counselors. Limited to fifty girls, 5-16 years. Fifty acres. All sports; ocean and still water bathing. For catalogue, address

MISS C. B. HAGEDORN, 606 West 137th Street, New York City

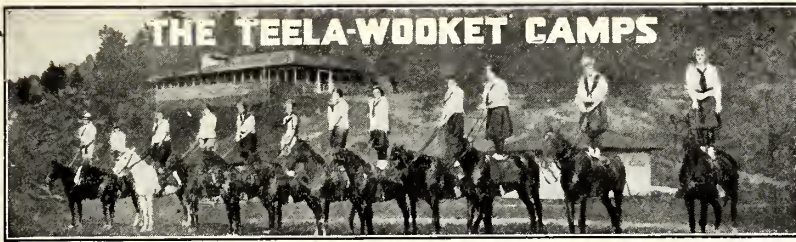

Senior and Junior Camps for Girls (under 20), Roxbury, Vt.

## Teela-Wooket Days Are Near

*Dear Girls:*

*5th Letter*

Each day that brings vacation time closer is counted as one step nearer to a joyful meeting with many of our ST. NICHOLAS friends at Teela-Wooket. Our summer home will be filled with merry girls from all over the country, who have come to enjoy with us all the good times that crowd the summer days at camp.

Many of the girls who have been at Teela-Wooket before are bringing other girls back this year, so you ST. NICHOLAS girls who have delayed registering should send in your applications at once. We should be sorry to have to disappoint you if you wait too long.



Each year Teela-Wooket puts on a new dress of beauty to welcome back the girls who laugh and sing and live through the happy camping weeks. Each year is new

even to the girls who come year after year. Each year there is some new way to enjoy the days among the wooded hills and along the white mountain roads.

Camp pleasures are never tiresome. The summer weeks hurry by, filled to the brim with wonderful experiences. When camps days are over the fortunate girls, who lived the vacation time far from the hot crowded streets of the cities, among the cool forests around the camp, go home made new by the wonderful medicine of sunshine and fresh air.

And what a store of memories for the long months till summer comes again! Of camping trips when days and nights are spent far from camp, living around the campfire, sleeping beneath the blue summer night sky with the stars to light them to bed. Of wonderful meals cooked over the red campfire. Of stories and song and moonlight over the mountain peak.



Of days that held their fair amount of horse-back riding. And what a wonderful thing was that! To mount a gentle horse, itself one of your best camp pals; to trot and canter along the white roads; to ride knee to knee with some good chum, fairly tingling with the pure joy of being alive. Or how about the big swimming pond up the mountain side that brought each day its hour of pleasure! And the hours around the "Big Bunk" fireplace toasting marshmallows, or the dances and the good things to eat at every meal and the—well, just everything that made camp life the pleasantest time of all the year. We can't tell all the things that mean so much to each girl that comes to Teela-Wooket. We can only hope that you will come and join us, and all the fine girls this summer, in having a real good time.

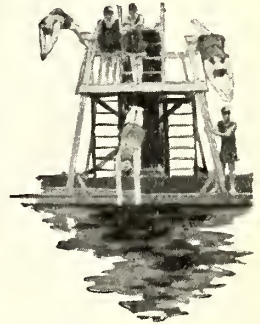

If you will send for one of the new Teela-Wooket booklets you can see many pictures of this Wonderland Camp in the Green Mountains and read of the many things the girls do there each summer. And if you really want to come to Teela-Wooket you will have to send in your name soon.

We will send your brother a booklet about Camp Idlewild on Lake Winnepesaukee, a splendid boys' camp, if he will write to us.

Very sincerely your friends,  
**Mr. and Mrs. C. A. Roys**  
 10 Bowdoin Street  
 Cambridge, Mass.





## KAMP KETEPEC

for Girls

Under Auspices of Columbia Preparatory School

An ideal spot, located on 1200 acres, in the heart of the beautiful Allegheny Mountains. Swimming, Canoeing, Riding, Athletics. Our function is to equip red-blooded girls with vitality, strong will power, sound bodies and clean companionship. Complete equipment, best of food, finest of supervision. Nine weeks, June 29 to September. \$325 Fee. Booklet on request.

**Mrs. Arthur N. Clawson**

Managing Director

301 W. 88th St., New York



## CAMP ABENA

For Girls

Healthful, happy camp of absolute completeness, on isolated peninsular, but easily accessible. Juniors (8 to 11 yrs.), Middlers (11 to 14 yrs.), Seniors (14 to 19 yrs.). Separate units. Horseback riding a specialty. Skilled equestrienne as instructor. Four-day canoe trips, always within ten miles of camp. Swimming, baseball, golf, tennis, crafts, dancing, dramatics. Helpful sympathetic counselors. Special trips to Mount Desert, Quebec and other places of interest. Booklet.

**Miss Hortense Hersom**

Biscayne Bay School, Miami, Florida  
After May 1st, Belgrade Lakes, Maine.



WISCONSIN, Rhinelander.

## CAMP BRYN AFON FOR GIRLS

1600 feet above sea level. Screened Sleeping Bungalows with hardwood floors; Saddle horses; Athletic Field; Craft House; All land and water sports; Counselors College Women. All positions filled. Booklet.

Lotta B. Broadbridge,

The Palms, 1001 Jefferson Ave., Detroit, Mich.



## CAMP TEGAWITHA

FOR GIRLS

MT. POCONO, PA.

An ideal camp in an ideal location in the famous Pocono Mountains—2000 feet above sea level. Electric light, hot tub and shower baths. All land and water sports, horseback riding, tramping, nature study, arts and crafts. Resident physician. Experienced counselors. Wholesome, well prepared food and pure water. Health and safety given first consideration. For booklet, address

**MISS MARY ANGELA LYNCH** Mt. Pocono, Pa.

PENNSYLVANIA, Philadelphia, 404 W. School Lane.

## PINE TREE CAMP

For Girls. On beautiful Naomi Lake, 2000 feet above sea, in pine-laden air of Pocono Mountains. Four hours from New York and Philadelphia. Experienced counselors. Horseback riding, tennis, baseball, canoeing, "hikes." Handicrafts, gardening, 11th year.

MISS BLANCHE D. PRICE.

MASSACHUSETTS, Falmouth.

## MARICOPA CAMP

A camp for young girls (7-14 yrs.) at Falmouth, Mass., among the pines and dunes of Cape Cod, the most invigorating climate in U. S. Experienced counselors. All outdoor sports. Number limited. Write for booklet.

Mrs. L. C. Wood, 451 W. Brighthurst St., Germantown, Philadelphia.

**COME TO QUINIBECK LAKE FAIRLEE VERMONT**

**ITS AIM:** To make Girls healthy and strong, happy and contented, self-reliant and self-restrained.

For Information Address  
**WILLIAM W. CLENDENIN, A.M.**  
 120 Vista Place Mt. Vernon, N.Y.



**The Tall Pines**

*A Summer Camp for Girls*

**Camp 7 to 18. Eighth Season. Club over 18.**

On Lake George, at Bennington, N. H., the camp nestles among the pines—as healthy a spot as can be found anywhere. Athletics, swimming, boating, canoeing, tennis, basket-ball. Camping trips, mountain climbing. Folk dancing. Special opportunity for horseback riding. Arts and crafts for rainy days. Good food well cooked, home care and attention. The Club accepts Campers for a week or longer. In writing state whether you are interested in Camp or Club. Catalog. Address

Miss Evelina Reaveley, 12A Beacon St., Gloucester, Mass.



**CAMP WINNESHEWAUKA**

*For Girls*

**LUNENBURG, VERMONT**

In White Mountain region. Mile of lake shore. Free horseback riding, water and field sports, handicrafts, music and dancing under expert instructors. Sponson and war canoes. Screened bungalows. Spring and artesian well water. Perfect sanitation. Best of everything for the best girls. Booklet on request.

**HERBERT F. BALCH, Dept. S, St. Johnsbury, Vt.**





# Wynona

A Girls' Camp Differing From Others

Lake Morey, Fairlee, Vt.

A summer at Wynona is a summer of unending pleasure. Horseback riding on fine Kentucky saddle horses. Skilled instructors to teach real horsemanship. Canoeing on beautiful Lake Morey and the Connecticut River. Hiking and camping among the pine-covered mountains. All athletics at camp. Golf and tennis. Comfortable bungalows equipped with electric lights and running water. Experienced

councilors, splendid girls for chums and companions. For illustrated catalog, address

**WYNONA CAMP**  
283 Summer Street  
Fitchburg Mass.  
*Lake Morey Club—a modern hotel under same management*



## Camp Wuttaunoh for Girls



on Crystal Lake  
Canaan, N. H.

Location, equipment and service of the best. Riding, water sports, field sports, tramping, nature work, handicrafts, and social activities. Number limited to 50. Catalog.

□

Prof. and Mrs. E. A. SHAW  
Northfield, Vt.



## HANOUM

Camps for Girls



Foothills of Green Mountains. Hill camp for girls under 15. Lake camp for girls over 15. Highest ideals of comradeship and sportsmanship. Gypsy trips, horseback riding, water sports, canoeing. Write for illustrated booklet.

**PROF. and MRS. C. H. FARNSWORTH**  
Teachers College, Columbia University North York, N. Y.  
*All counselor positions filled.*



## The call to CAMP SERRANA

LAKE TARLETON, PIKE, N. H.

In the foot-hills of the White Mountains, 1500 feet above sea level. Comfortable, protected tents on well-drained hillside. Modern, sanitary equipment. Shower baths. Land and water sports. Mountain climbing, horseback riding, campcraft, nature lore. Tutoring if desired. Trained nurse in residence. Conducted by Mrs. Mary Gaylord Frick. ILLUSTRATED BOOKLET.

Until June 3rd, address

CAMP SERRANA, 559 West End Ave., New York



Seventh Season  
**GIRLS SENIORS  
JUNIORS**  
Careful selection of personnel

## CHAMBERS ISLAND

"3000 ACRE CAMP FOR GIRLS"

The gem of the Great Lakes. Present owner's former summer home. Fine buildings. Two hundred wild deer—Golden pheasants. Interior lake for aquatic sports. Basketball, Tennis, all other sports, directed by experienced councilors. Arts and Crafts, Dancing, Music, Dramatics, Horseback Riding. All modern conveniences. Limited enrollment. For booklet and information, address

Mrs. Edward J. Barrett, Pres., 222 Michigan Avenue, Sheboygan, Wisconsin

## PENNSYLVANIA, Philadelphia. CAMP MINNETONKA

Girls 10-18

Monmouth, Me. The "FOUR LAKES" camp. Exploring in four lakes. Swimming taught. All safe sports. Modern equipment. Excellent meals. Refined councilors. Personal interest taken. Booklet. Coun. pos. filled. 1000 ft. of lake shore. GEO. W. RIEGER, JR., Box J, 1103 Harrison St., Phila.

## MRS. NORMAN WHITE'S CAMPS

Orleans, Cape Cod, Massachusetts

Located among the pines on Cape Cod. All pleasures of life by the sea. *Owaissa*: for girls 12 to 18. *Mayflower*: for girls 8 to 12. Limited membership.

Mrs. Norman White

Tel. Morningside 3350 424 West 119 Street, New York City

For  
Girls

## CAMP TWA'NE-KO-TAH

On Beautiful Lake Chautauqua, N. Y.

Located on 50 acres of picturesque land at gateway of the Middle West. 1500 ft. elevation. All land and water sports, horseback riding, hiking, dramatics, interpretative dancing, handicraft. Home care. Complete equipment. Senior and Junior Camps. Write for Illustrated Booklet.

REVEREND R. CARL STOLL  
5 College Hill Snyder, N. Y.



## Summer Camps for Girls — Continued



# QUANSET

## Cape Cod Sailing Camps for Girls

*On Pleasant Bay, South Orleans, Mass.*



**PIONEER** Salt Water Camps Established 1905. Junior Camp—ages 9-13. Senior Camp—ages 13-18. Full fleet of staunch sailboats. Learn to sail in safe Pleasant Bay with our cautious Cape Cod skipper. The Quanset racing knockabout sails the Chatham Country Club Races.

Safe salt water swimming and canoeing—experienced instructors always present. Campcraft and trail lore in hands of R. F. Hammatt

(Harvard S. B.), ten years U. S. Supervisor of the Shasta National Forest, Calif. Horseback riding, tennis, team games, dancing, music, handicrafts, nature study. Strong organization of expert councilors. Modern sanitation and comforts. Camp farm supplies good wholesome food.

The same personal care and supervision by the directors.

For booklet, address

MR. and MRS. E. A. W. HAMMATT, Box 10, South Orleans, Mass.

# Sargent Camps

PETERBORO, N. H.

*The Athletic Camps for Girls*

Promotes a healthy, happy, useful life. Skilled leaders. Woodcraft, water sports, hiking, horseback riding, games, dramatics, music, dancing.

Senior Camp for girls from 15 to 20.

Junior Camp. Unexcelled equipment. Homecraft for little folks.

Sargent Club. A distinct unit with all camp privileges for girls over 20. Campers accepted for two weeks or more, July to Sept. inclusive.

For illustrated booklet address Camp Secretary, 8 Everett St., Cambridge, Mass.



*Camp Mystic owns the Northern Light, 65 passenger 60 H P. 54 feet over all—speed 20 miles an hour*

# CAMP MYSTIC MYSTIC CONNECTICUT

## "MISS JOBE'S CAMP FOR GIRLS"

The salt water camp for girls. Half way between New York and Boston. Life in the New England hills, woods, and by the sea. Unusual buildings, tent bungalows, tennis courts. Shower and tub baths. Modern sanitation. Salt water sports, motorboating, swimming, safe canoeing, horseback riding, dancing, field athletics, arts and crafts, dramatics. Camp life and trips under the personal direction of Miss Jobe, who has had ten seasons of practical experience (summer and winter) in camping and exploration in the Canadian Rockies. Care for the safety and health of each camper. Juniors and Seniors. Age 8-18. Ill. booklet.

MARY L. JOBE, A. M., F. R. G. S.

Room 63, 50 Morningside Drive, New York

# Camp Alkyris FOR GIRLS 10 TO 18

115 Acres of picturesque woodland, with 2,000 feet of water front on Sebago Lake, Maine. One hour from Portland. Unexcelled equipment for all camp activities, including field sports, dramatics, dancing, arts and crafts; and all water sports, including sailing, motor-boating and canoeing. Modern sanitation. Camp leadership under direction of skillfully trained graduates of schools of physical education. For booklet, address

MRS. MALCOLM R. LAWRENCE  
611 Second Street Brooklyn, New York  
Telephone 6819



NEW HAMPSHIRE, Portsmouth.

# CAMP BEAU RIVAGE

(French Camp for Girls)

All sports by land and sea. Address Secretary  
57 East 74th St., New York City.

NEW HAMPSHIRE, Stinson Lake.

**CAMP EAGLE POINT** High among the White Mts. on Stinson Lake, N. H. Fully equipped for all camp activities, electric light, running water, hot baths, excellent cuisine. Trained leaders. Riding and Touring.  
VIRGINIA E. SPENCER, Ph.D. Secretary, 220 W. 42nd Street, New York.

## SELECT THE BEST CAMP

for your boy or girl. We shall be glad to help you choose the right camp in the right environment. State age, location preferred and rate. Experienced counsellors. **NO CHARGE.** Address

Director School and Camp Service,  
THE NORTH AMERICAN Philadelphia.

MASSACHUSETTS, West Springfield.

**CAMP YOKUM** For Girls. Situated on the shore of a beautiful lake almost at crest of Berkshire Hills. Altitude 1875 ft. Best of instructors, attractive responsible councilors. Term eight weeks. \$250 includes everything except tutoring and horseback.  
MARY E. RICHARDSON, 69 Woodmont Street.



Summer Camps for Girls—Continued



Send for **CAMP AMERICA** *Descriptive Book*  
**CATHOLIC CAMP FOR GIRLS**

**SOME OF THE FEATURES:**—Forty-acre Sport Field—900-acre Estate—Its Own Farm—Pure Drinking Water—Boating—Swimming—Horseback Riding—All the Field Sports—Nature Study—Arts and Crafts—Fine Arts—Electrically Lighted—Tub and Shower Baths—Perfect Sanitation—Seven Tallyhos—Dancing—Moving Pictures—Radio Outfit—Large Assembly Halls—Only Balsam Grove in Vermont—Substantial, Permanent Buildings—Attendant Physician—Nurse—Dentist—Bowling Alleys—Abundance of Wholesome Food—Opens for Fourth Season June 29, 1922.

**CAMP AMERICA**  
 Lake St. Catherine Poultney, Vermont

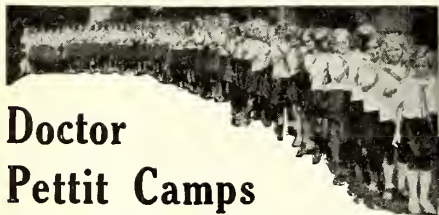

**Doctor Pettit Camps**

*Three Separate and Distinct Salt Water Camps for Girls at Shelter Island, N. Y.*

Extensive water front on two bays. Excellent sailing and all water sports. Riding, woodcraft, field games, hiking, dancing and handicrafts. Wonderful surroundings. 100 miles from New York. 140 miles from Boston.

**MANHANSACK** for Girls 7-13  
**SEWANHAKA** for Girls 14-20  
**PECONIC** for Grown People

Mother and daughter or sisters may be near each other while at separate camps. For illustrated booklet address

**Henry D. Pettit, M.D.**

(27th Year as Camp Owner and Director)

106 Gates Avenue,  
 Brooklyn,  
 New York

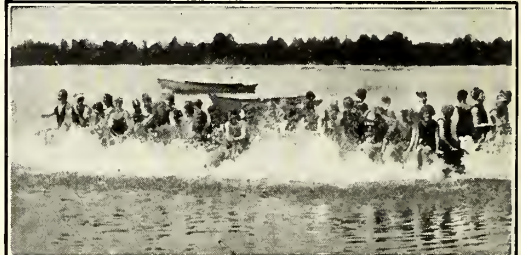
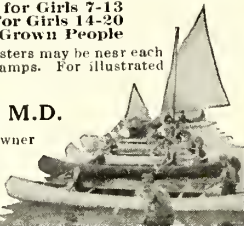

**WINNEMONT** *A Camp for Girls*

On Lake Ossipee, in the foothills of the White Mountains. Special attention to happiness, health and safety. Automobile trips to our White Mountain Camp. Canoeing, swimming, sailing, horseback riding, archery, and all sports. For illustrated booklet, address Mr. and Mrs. W. H. Bentley, Elinor C. Barta, Room 205, 14 Beacon St., Boston, Mass.

NEW YORK, Yonkers, Lowerre Summit Park.  
**WYODA** Home Camp for Young Girls, Lake Fairlee, Vt. New bungalows, 130 acres, sandy beach, main house, open-air dining hall (screened). Tennis and basket-ball courts. Large athletic field, riding, swimming, canoeing, weaving, handicraft, woodcraft, dancing, dramatics, nature study, mountain trips, tutoring.  
 Mr. and Mrs. HARVEY NEWCOMER.

WISCONSIN, Green Lake.  
**SANDSTONE CAMP**  
 Eleventh season. Three divisions, ages 8 to 24. More activities offered than in any other camp in the west. Thirty specially trained councilors. A Camp where only the best satisfies. Address  
 ESTHER G. COCHRANE, 3722 Pine Grove Avenue, Chicago.

## Summer Camps for Girls — Continued

**CAMP AMICORUM** 8 weeks \$150, includes fares from Boston for a limited number of girls who will be given a mother's care. Excellent food and well water. Recommended by physician. Swimming, sports, picnics, weekly trips, carefully supervised. Riding if desired. Resident nurse. Delightful seatrip, seventeen hours from Boston, staterooms provided, and hour's auto ride to Carleton, Nova Scotia.  
MRS. ELDRIDGE, Woodland Ave., Beverly, Mass.

NORTH CAROLINA, Waynesville.

### EAGLE'S NEST CAMP for Girls

Junior and Senior. Land and water sports; nature lore; handicraft; dramatics. College staff. Tutoring by request, no charge. Select associates. Limited numbers. 20 Exquisite acres; 3000 feet high; 2½ miles from town. Safety spelt with capital S; Health with capital H. Excellent food. EAGLE'S NEST CAMP, 620 E. 40th St., Savannah, Ga.

### CAMP EL RETIRO

Camp for girls 6 to 16 yrs.—on Butterfield Lake, Redwood, N. Y. Near St. Lawrence River and Thousand Islands. Hiking, fishing, safe boating, bathing. Large main camp. Either Lodge sleeping quarters or open canvas cottages. Registration limited. \$250.00 from June 20th to Sept. 20th. Longer stay can be arranged. Address Mrs. Clarence N. Cook Redwood, N. Y.

NEW YORK, New York City.

### CAMP WINNAHKEE FOR GIRLS

Among the pines on Mallett's Bay, Lake Champlain. Best equipment. Healthful environment. All land and water sports; horseback riding, motor-boating, dramatics, dancing, handicraft. Experienced counselors. Trained nurse. 7th year. Booklet.

MRS. W. M. H. BROWN, 307 West 83rd Street

MAINE, Oxford.



**Navajo** on Lake Thompson, July 1st—Aug. 27. Terms \$250 (no extras). The Camp of high standards, for fifty girls (8-20 years). Riding, Mt. Climbing. All land and water sports. Handicraft. Hikes. Two-day White Mt. trip. Every care of director and experienced counselors. Nurse. References. Catalog. CLARA HENDERSON, Director, 1619 Eutaw Place, Baltimore, Md. (until June 20).



### WINNETASKA

THE CANOEING CAMP FOR GIRLS

SQUAM LAKE, ASHLAND, NEW HAMPSHIRE

DR. and MRS. JOHN B. MAY

WINNETASKA LODGE, COHASSET, MASSACHUSETTS



A—T LAKE WINNIPESAUKEE.

C—AMP ACADIA FOR GIRLS.

A—LL LAND AND WATER SPORTS.

D—O YOU WISH TO JOIN US ?

I—LLUSTRATED BOOKLET.

A—GE LIMIT 8 TO 16 YEARS.

DR. and MRS. J. GRANT QUIMBY, Lakeport, N. H.

14th  
Season



### SILVER LAKE CAMPS

For Girls. In Lake Placid Region of the Adirondacks. Separate Camps—Juniors, 8-14; Seniors, 14-20.

Every provision for comfortable, pleasant camp life. Lake and mountains combine to form a beautiful playground. Canoeing, horseback riding, swimming, mountain climbing. Expert directors for every activity. Registered nurse. Open-air dining-room and sleeping porches. References required. Catalog. Address Secretary, Silver Lake Camps, 2 Tennis Court, Flatbush, Brooklyn, N. Y. Telephone 0122 Flatbush.

### Wetomachek Camps for Girls

Powers Lake, Wisconsin



Under the management of The Chicago Normal School of Physical Education

Junior and Senior Camps. July and August. For Girls, ages 9 to 22. A strong force of trained counselors. References required.

Write for Booklet, Registrar

Box 18

5026 Greenwood Ave., Chicago, Ill.



Altitude  
1400'  
above S. L.

HELDERBERG MOUNTAINS  
ALBANY CO., N. Y.

Does your girl enjoy *Water Sports*? Does she like *Athletics*? Is she interested in *Handicraft Work*? Would you choose *Experienced College Graduates* to supervise her *Daily Routine*? Do you want her to enjoy an *Ideal Summer Out of Doors*? Then Enroll her at

Orinsekwa "The Camp in the Pines"

Non-Sectarian — For further information apply to  
JEANNETTE FRANK, A. B., A. M., 529 West 179th Street, New York

VIRGINIA, Bristol.

### CAMP JUNALUSKA

One of the finest "all around" camps for girls in the south. Lake Junaluska, N. C., the "Land of the Sky." Swimming, canoeing, mountain climbing, horseback riding, dancing, handicraft, music and dramatics, all under careful supervision. Write for booklet.  
Miss ETHEL J. McCox, Director, Virginia Interment College, Bristol, Va.



## CAMP NEWAKA

For Girls. Gold Lake, Colorado

Between Boulder and Estes Park, in the heart of Nature's Playground. All the activities of healthful camp life, with riding a feature, offered to a limited number. No extras. References required. For booklet, write to

HELEN J. MACDONALD, MARY K. VOORHEES, *Directors*,  
4600 McPherson Avenue, St. Louis, Missouri.

## CAMP WAH-WAH TASSIE

A salt water Camp for girls 8 to 18 yrs.

West Dennis, Cape Cod, Mass.

Unusual results in health and vigor. Special attention given to diet. Well-cooked, well-balanced and satisfying meals. Land and water sports under competent councillors. \$15.00 Per week.

Booklet

MARY E. HOEY, Dover Point, N. H.  
After June 15th, address West Dennis, Mass.

## Century Books for Young People

# THE DRAGON'S SECRET

By AUGUSTA HUIELL SEAMAN

Author of "The Boarded-Up House," etc.

**A** MYSTERY story centering about a dragon-shaped box found buried in the sands near a mysteriously haunted empty summer bungalow at the seaside. Two girls and a boy have thrilling experiences in the course of finding out what it is all about. A clean, healthy-minded story, like all of this popular author's work, it is at the same time intensely exciting, genuinely puzzling, and wholesomely stimulating.

*Illustrated. Price \$1.75*

## THE HAPPY VENTURE

By EDITH BALLINGER PRICE

Author of "Blue Magic," etc.

**A** CHARMING story, delightfully told, of how a big lad and his sister and a little blind brother take an old farm and contrive to make a living, find interesting friends, discover an open door to happiness for the little blind boy, and play an important part in some dramatic happenings. The story is full of both interest and charm. There is a hint of mystery, a breath of the sea, and, above all, a warm and appealing humanity. The author has done the pictures as only an author could, in full sympathy with the story-people.

*Illustrated. Price \$1.75*

## DRIFTWOOD

By RAYMOND S. SPEARS



**A**N IMPRESSIVE story of the tremendous phenomenon of a Mississippi flood and the exploits of two boys upon it. They are not impossible heroes, but real and natural, though unusually brave and resourceful boys; and the rise of the river and its irresistible overflow, the damage, peril, suffering and strange situations which it causes are the result of close observation and long knowledge of the great river and the dwellers on its waters and its shores. A thoroughly

American story of youthful ingenuity and grit in a situation typically American.

*Illustrated. Price \$2.00*

At All Bookstores  
Published by

## THE CENTURY CO.

353 Fourth Avenue  
New York City

# SUMMER CAMPS FOR BOYS



## CAMP PASSUMPSIC

*Lake Fairlee, Vermont*

The Ideal Camp for Young Boys where the Aim is Health and Happiness.

*Illustrated Booklet on Request.*

WILLIAM W. CLENDENIN, A.M. 120 Vista Place, MT. VERNON, N.Y.



MASSACHUSETTS, West Harwich, South Shore, Cape Cod.

**CAMP MON-O-MOY** For Boys. Modern equipment; managed by experienced educators; camp mother; magnificent beach; superb swimming; sailing; canoeing; deep sea fishing; baseball, basket-ball, tennis. Expert tutoring. Illustrated Booklet. HARRIMAN R. DODD, *Executive Officer*. Worcester Academy, Worcester, Mass.

## MITIGWA CAMP

Dodge Pond - - - Rangeley, Maine



Where forest trails and waters are waiting. Canoe and mountain trips with guides.

Water sports and athletics with leaders who know how. The membership is limited.

A booklet on request.

J. W. Fairchild, Jr., 48 Grove Street. Pawtucket, R. I.

9th Year **CAMP** For Boys ON OTSEGO LAKE  
7-15 **CHENANGO** COOPERSTOWN, N. Y.

*A Camp that grows thru its enthusiastic boys*

Only six hours from New York City

A parent writes: "My son returned home in *splendid physical condition*, much *improved* by reason of his summer outing. He tells us very *enthusiastic* stories of the *good treatment and care* which he received." All sports. Horseback riding.

Write for book: E. L. FISHER, 24 N. Terrace, Maplewood, N. J.

## BEAR MOUNTAIN CAMP

FOR BOYS

HARRISON, MAINE

In the pines, on the sandy shores of Bear Lake. Wonderful food, swimming, diving, fishing, camping and canoe trips, boxing, target practice, tennis, baseball, soccer, campfire stories, mountain climbing. A gloriously happy and healthful summer is offered by this ideal camp. Ages 7 to 17, tuition \$275.00 for eight weeks. Illustrated booklet S.

HAROLD J. STAPLES, *Director*

Biddeford, Maine



Summer Camps for Boys—Continued

**CAMP ★ VEGA**

CHARLESTON LAKE  
ONTARIO, CANADA

(Only 12 hours from New York City)

A select Camp for Boys. Limited number; Highest type of College counselors from Yale, Columbia, Springfield, Pittsburgh, Ohio State, Univ. of Toronto and Centre College of Kentucky. 1000 mile radio receiving set. Radio instruction. One of the finest equipped camps in America. Personal supervision guaranteed. Bungalow camp. 4 motor boats, sail boat, excellent fishing. Doctor and trained nurse always in camp. References required. For booklet or personal call by the Director, write

WILLIAM S. HAZEL  
16 West 47th Street New York City

**ASH-NO-CA**

"A BOYS' CLUB"

IN THE MOUNTAINS OF NORTH CAROLINA

Not a school, not a camp, but a place planned, equipped, and conducted for the pleasure and physical and moral welfare of boys under seventeen during the summer. Delightful climate. No mosquitoes. Sports include hiking, mountain climbing, camping, canoeing, swimming, boating, tennis, baseball, track, golf, EVERYTHING A BOY LIKES. Fine buildings furnish healthful sleeping accommodations and other buildings ample place for recreation in wet weather. Boys have best possible care. Large farm furnishes abundance of wholesome food. 714-acre Tract.

Address George Jackson, Asheville School - Asheville, N. C.



**DAN BEARD  
WOODCRAFT CAMP**

To be a Woodcrafters in personal touch with the real Dan Beard is a rare privilege. Are you going to be one of them? Membership limited. In charge of the famous scout himself. On beautiful Pennsylvania mountain lake. All the outdoor activities that boys like. Sound physical, mental and moral training. No extra charge for tutoring. Specially endorsed by ex-President Roosevelt.

Apply 89 Bowne Avenue, Flushing, L. I., N. Y.



**CAMP TY-GLYN** A CAMP FOR BOYS 7 to 17  
MOWYN LAKE, ROOSEVELT, WIS.

Horseback riding, tennis, canoe trips with guides, swimming, baseball, basket-ball, manual training, wireless telegraphy. All counselors college men, each one a specialist. For booklet, write to  
G. A. ROGER, 700 W. Euclid Avenue, Detroit, Michigan.

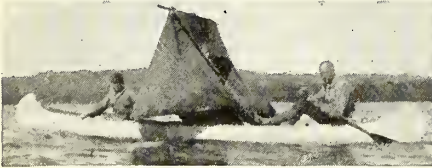

**CAMP KINAPIK**

The Woodcraft Camp for Boys from 8 to 16  
ON LAKE KEZAR, MAINE

Come to the lakes, woods and rivers of Maine; the White Mountains of New Hampshire. Swimming, Fishing, Council fires. Secrets of camp and woods. Mountain trips and camps. Canoe trips near and far. Wilderness and special trips for older boys. Age groups. Particular supervision. Resident physician. Camp mother. Endorsed by Ernest Thompson Seton. For illustrated booklet, address  
HARVEY C. WENT, Director, Bridgeport, Conn.

**ROTHERWOOD**



**BOYS —  
Hurrah for the Maine Woods!**

You never will enjoy real camp life at its best until you swim in the clear Maine lakes, canoe up the wonderful streams, hike through the deer-tracked forests and sleep under the enormous pines. At Rotherwood Camp there are such glorious days for boys! Such wonderful sports and fine eats! Mother and father will be glad to have you go to Rotherwood—it's just the place they would pick out, with fine boys for chums and everything the best. Write us for our booklet "B."

**CAMP ROTHERWOOD - Alfred, Maine**

**Camp "De Luxe" for Boys**

All out-door games and water sports

Parents: If you want to place your boy during the summer under healthful, wholesome, safe care and charming environment, write for illustrated booklet and terms.

The Champlain Algonquin Camps for Boys  
Port Henry, New York

**CAMP CONTOCOOK**

East Jaffrey, N. H.

Featuring golf, a new attraction for Summer Camps, also bowling, athletics, mountain climbing, hikes, and water sports.

For booklet, address

FRANK W. MOSES, Carnegie Institute of Technology, Pittsburgh, Pa.  
LESLIE WOOD, Manual Training H. S. or  
383 St. John's Place, Brooklyn, N. Y.

## Summer Camps for Boys—Continued

### KAMP KOLUMBIA

*for Boys*

Under Auspices of Columbia Preparatory School

Over 1200 acres of mountain, stream and woodland, in the heart of the beautiful Allegheny Mountains. Property that was formerly a splendid private fishing and hunting preserve. All athletics, aquatics and woodcraft, canoeing, mountain climbing, riding, etc. Life that develops a vigorous body, alert mind and strong character. Fee, \$325. Nine weeks, June 29 to September.

**Dr. Arthur N. Clawson**

*Managing Director*

301 W. 88th St.

New York



### Camp Winnecook for Boys

*Lake Winnecook, Unity, Maine*

20th Season. Athletic fields for all Sports. Horseback riding, canoeing, sailing, motor-cruising, Indian tribes, head-dress for deeds of valor. Indian pageant. Woodcraft, auto trips, hikes. Photography; Arts and Crafts. Tents and bungalows in pines. Every boy takes part in everything.

*One price—No extras. Send for booklet.*

**Herbert L. Rand, 3 Hemenway Road, Salem, Mass.**



### Walkill Camping Club for Boys

New Paltz, N. Y.

An ideal, high class camp for boys; beautifully located. Planned and organized on club basis, so that camper realizes full value for money invested. Request full information and Prospectus from

**C. J. STEIN, Director**

Walkill Camping Club for Boys

26 Cortlandt Street, New York City



### MINNE-WAWA—Last Call!

*Permanent Summer Camp for Boys and Young Men*

Fun, fun, FUN—fishing, canoeing, swimming, tramping—at Camp Minne-Wawa, Lake of Two Rivers, Algonquin Provincial Park, in heart of Ontario Highlands. Wholesome moral atmosphere. Plenty of good food. Highest references. Reasonable terms. Write **W. L. WISE, Ph.B., Bordentown, N. J., for Booklet D.**

### CAMP MADISON for BOYS

Will Accommodate 100

Madison, N. H. In the Heart of the Mountains.

For Booklet and Information, write

**H. E. CUNNINGHAM, 34 School Street, Room 48, BOSTON, MASS.**

Residence, 3 Freeman Street, Arlington, Mass.



Summer Camps for Boys—Continued

# CAMP KATAHDIN

FOREST LAKE, SWEDEN, MAINE

Juniors Seniors Trips Athletic Conditioning  
For Boys and Young Men

A camp with 22 years of splendid traditions. Appointments of camp, simple. Real camp life. Health conditions exceptional. Activities include real mountain and canoe trips, all branches land and water sports, horseback riding, woodcraft, nature study, tutoring.

Special athletic training season continues to September fourteenth.

Number limited. References required. Send for booklet, giving age and pertinent facts.

George E. Pike, B.S.  
Ralph K. Bearce, A.M.  
Duxbury, Mass.



# Lanakila

Fairlee  
Vermont

The  
Aloha Camp  
For Boys  
Ages 8-13



Aquaplaning

On Lake Morey. All water sports including motorboating and aquaplaning. Athletic fields. Horseback riding. Woodcraft. Treasure hunts. Craft shops. Vigilance for health and safety. Aloha Camps for Girls under same management. For booklets, address Mr. E. L. Gulick, 505 Addington Road, Brookline, Mass.

College Preparation and School Work combined with Outdoor Life on a big Ranch in the High Timbered Rockies.

Study and Recreation carefully supervised. Complete equipment.

Camping Trips with Pack Horses.

Invigorating Climate—7500 feet above sea level. Limited to 20 boys.

A. J. Connell, Director  
LOS ALAMOS RANCH SCHOOL  
OTOWI, SANDOVAL COUNTY  
NEW MEXICO



# CAMPS Information

FREE catalogs and advice of experts on ALL Boys' or Girls' camps also private schools in U. S. Relative standing from personal inspection. Bureau maintained by the schools. State fully kind wanted. No Fees. Call, write or phone

Seven  
Tele-  
phones

AMERICAN SCHOOLS  
ASSOCIATION  
Times Bldg., New  
York or Masonic  
Temple, Chicago



NEW YORK, Woodland.

## CAMP WAKE ROBIN

Younger boys exclusively. Eighteenth season. Make your boy strong, happy, through an out-of-door life, including woodcraft, hiking, nature-lore, manual training, swimming, and all sports. Matured supervision and modern sanitation. Booklet.

Mr. H. N. LITTLE, New Jersey, Jersey City Lincoln High School.

WISCONSIN, Fish Creek.

## CAMP WILDWOOD

For Boys. Write for catalogue.

Mr. and Mrs. W. B. BIRD,  
3273 Berkshire Road,  
Cleveland Heights, Ohio.



# CAMP WANAKI

An Ideal Boys' Camp in the  
MINNESOTA NATIONAL FOREST

Write for Booklet

The Northwoods Camps Co., 509 Ludlow Bldg., Dayton, Ohio

PENNSYLVANIA, Mehoopany.

CAMP FERN Admits boys 8 to 16 years old. Located at Mehoopany, in the Allegheny mountains of eastern Pennsylvania. Excellent climate. All sports. Tutoring free. Minimum rates. Until June 10th, address B. M. SLATER, Box 82, Long Valley, N. J. After June 10th, address CAMP FERN, Mehoopany, Pa.

## Summer Camps for Boys—Continued



### KAMP KILL KARE

The camp of happy times for clean boys. All the outdoor and indoor sports that a well regulated camp should have. Here there is play and diversion that mean well spent days for live American boys. An illustrated booklet on request.

R. F. PERRY, Principal  
Box M  
Morristown High School  
Morristown, N. J.



### CAMP DUNCAN PERU, VERMONT "In The Scotland of America"

Trips into unbroken Wilderness. Swimming, Mountain Climbing, Fishing, Hiking, Sports. Individual attention. An Exclusive Camp for Twenty-five Boys. Fully equipped for their happiness and health. Equipment includes workshop, Wireless, piano, victrola, books and games. Mr. Grant, the Director, is an expert in the science of good health. Good Food, Fresh Air, Proper Exercise, and No Worries, The Fundamentals of Good Health. For Illustrated Booklet write CHAS. H. GRANT, 22 E. 10th St., N. Y. City. Tel. (Stuyvesant 1152). (Call after 6.30 P. M.)



### CAMP YUKON for Boys Winthrop, Maine

This Camp guarantees that your boy will have proper supervision, including medical care and matron's attention; that he will have good and sufficient food. Sanitary conditions modern, equipment for land and water sports complete, including horseback and golf. The location is in a grove at Lake Combessecontee's shore, near good tarvia roads and four miles from the railroad. Choice of tents or bungalows. New large Main Hall furnishes plenty of space for dining, indoor recreation and shelter from stormy conditions. 9th Season.  
Frank D. Smith, 353 East 163 St., N. Y., Melrose 3370

## THE TOLTEC CLUB A Summer Camp FOR BOYS In the Connecticut Hills

The unique feature of the camp is the camping tours throughout the New England states in the course of which many spots of historical and other interest are visited, mountains climbed and all sorts of adventures encountered. A splendid opportunity for boys. All kinds of athletic sports, swimming, boating, etc. Membership limited. For booklet, address:

THE DIRECTOR, 81 Jane St., New York

## BLACKWATER CAMP SCHOOL Cody, Wyoming

Fall and Spring terms in The Rocky Mountains.  
Winter term in The Florida Keys.

Write for Booklet

B. C. RUMSEY

### CAMP OSSIPPEE FOR BOYS UNDER 15 New Hampshire, on Lake Ossipee

19th Season on Lake Ossipee in White Mts. (125 Miles from Boston). Horses, Canoe trips; Ideal Swimming and Fishing; Science, Music, etc. Expenses moderate—Conducted like a Club by the Headmaster of one of the oldest and best-known private schools. For circular, address

O. E. GUILD, Secretary  
Nassau Place Peekskill, N. Y.

### For Boys CAMP TONKAWA 7 to 15 yrs. IN THE WOODS ON LAKE CHAUTAUQUA, N. Y.

An ideal spot for Junior boys. 1500 ft. elevation. One of the best equipped camps in the country. Riding, hiking, swimming, athletics, tennis, fishing, boating, manual training under the direction of matured men with high standards. Write for booklet.

REV. R. C. STOLL

5 College Hill Snyder, N. Y.

MARYLAND, Port Deposit.

## THE TOME CAMP FOR BOYS

On the Heights, above the Susquehanna, near Port Deposit, Md. Indian Trail Hikes. Chesapeake Bay Cruises. Susquehanna fishing, boating, swimming. Fine athletic fields. Special care for little boys. Christian Counselors. Rate \$225, July and August. Address,

MRS. I. T. BAGLEY, Supervisor, Port Deposit, Md., or  
B. A. McILHANY, Athletic Director, St. Christopher's School, Richmond, Va.

## St. Lawrence Cruising Camp for Boys

Cruising on large powerful yacht—camping on shore—inland trip Hudson River, Lake Champlain, St. Lawrence and Saguenay Rivers. Visiting Montreal and Quebec. Complete equipment, excellent food, experienced leaders, perfect safety. Boys 10-16. Moderate rate. Leave New York July 1st—return September 2nd. Booklet.  
Box 242, Sewaren, New Jersey.



## Summer Camps for Boys—Continued

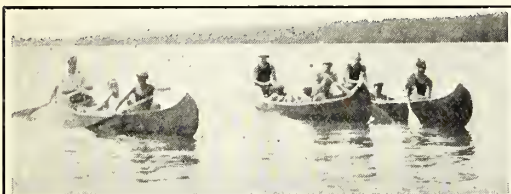

### CAMP NORRIDGEWOCK

For Boys Oakland, Maine

Offers to the boy the best that there is in camping. Three pine-covered islands of seventy-five acres on East Lake, one of the famous Belgrade Lakes. Canoe trips, fishing, tennis, baseball, swimming, football and tutoring. Modern sleeping bungalows. Experienced leadership. Camp mother. Boys eight to eighteen years.

May we send you an illustrated booklet?

ARTHUR M. CONDON - Northampton, Mass.



### Camp Sokokis

Bridgton, Maine. On Long Lake in the foothills of the White Mountains. Small home camp. "An acre per boy." Radio, Shop-work, Photography, Marksmanship. Land and water trips. Resident Physician. Sleeping bungalows. Booklet.

Lewis C. Williams 98 Rutland Road, Brooklyn, New York  
Telephone Flatbush 3774

NEW YORK, Catskill Mountains.

**KYLE CAMP** for boys, 6 to 16. Catskill Mts. Model bungalows—no damp tents. Fine bathing. Your boy's health and diversion well looked after. Movies. Modern equipments. Physician; nurse; scoutmasters; "The paradise for boys." Address DR. PAUL KYLE, Kyle School for Boys, Irvington-on-Hudson, Box 506.

### 'GREAT SUMMER VACATION

for younger boys. Swimming, Boating, Fishing, Camping, Hiking, Manual Training, Music, and as much school work under exceptional teachers as desired. The Woods and Lakes of Upper Ramapo Region, Orange County. Illustrated booklets.

MACKENZIE JUNIOR SCHOOL Monroe, N. Y.

CONNECTICUT, Bantam Lake.

### CAMP WONPOSET

A camp for young boys in the Berkshires. 100 Miles from New York City. Everything a boy can wish for. Write for camp book.  
ROBERT TINDALE, 31 East 71st St., New York City.

### POLE BRIDGE CAMP Matamoras, Pike Co., Penn.

A wonderful camp on a mountain top in the Water Gap region overlooking the Delaware, only 90 miles from N. Y. Modern equipment. Mountain, water and indoor sports. For 25 boys, 8 to 14 years. Booklet.

E. HOYT PALMER, Manager,  
751 Yale Sta., New Haven, Conn.



### CAMP PISCATAQUIS

Lobster Lake, Maine  
Eugene Hayden, Director

For boys 12-17. Offers a 250-mile canoe trip under famous guide from Lobster Lake to Fort Kent. Fishing, Hiking, Exploring. Your boy deserves the best. For booklet with map, write

H. J. STORER, Secretary, 74 Fayette Street, Cambridge, Mass.

NEW YORK, Manlius.

### CAMP MASSAWEPIE

In the Adirondacks. Wonderful location in virgin forest on shores of Lake Massawepie. Splendid equipment, buildings, club house, bowling alleys, baseball and tennis grounds. Sand beaches, good fishing. All land and water sports. Tutoring. Season July and August.

Colonel GUIDO F. VERBECK, Box S6, Manlius, N. Y.

CONNECTICUT, On Bantam Lake.

### SAGAWATHA LODGE

100 miles from New York City. Cabin Camp for 40 Boys. Ideal spot. Land and water sports. Athletic field, Underground Shooting-Range, Hiking and Canoeing. Camp mother, experienced Counsellors. For booklet or interview. Dr. J. H. HOBBS, To April 15, Hotel Albert, N. Y. City. After, Lakeside, Litchfield Co., Conn.

PENNSYLVANIA, Montoursville.

### CAMP LOYALSOCK for Boys

In the heart of the Lycoming County hills, an exceptional camp with an exceptional fee, \$100.00. All land and water sports under trained leaders. Best food. L. E. KLEPPER, Monument and Belmont Roads, West Park, Philadelphia.

### CAMP CHAMPLAIN

For Boys 7 to 16. On a Neck-O-Woods on Mallett's Bay, Lake Champlain, between the Green and Adirondaek Mts. A glorious vacation with canoeing, swimming, hiking, baseball, horseback riding. Careful supervision. 29th year. Booklet.

WM. H. BROWN, President Berkeley-Irving School, 307 West 83rd St., New York City



NEW YORK, Among the Thousand Islands.

### CAMP WE-E-YAH-YAH

Fifty boys, 8 to 17 years, will have a summer full of fun and healthful recreation: finest fishing; all land and water sports. Councilors. 8th Season. July, August—\$275. Booklet. H. H. BUXTON, 904 Newell St., Utica, N. Y.

### BOYS!

Did you ever see such a fine display of camp advertisements as those on the preceding pages? We feel sure that you will find a camp there suited to your wishes, whether it be in the wilds of Canada or in the heart of the Rockies.

For further information address

The Camp Service Bureau of  
ST. NICHOLAS MAGAZINE  
353 Fourth Avenue New York City

## Summer Camps for Boys—Continued



### CAMP WAMPANOAG

16th Season Cape Cod, Buzzards Bay

A salt water camp for boys from 8 to 16. Scouting over old Indian trails. Land and water sports, prizes. Athletics under experienced college men. Instruction in life saving. Military drill. Camp mother. Booklet.

MRS. BERTRAND E. TAYLOR, *Director*  
MR. ALDRICH TAYLOR, *Advisory Director*

240 Grant Avenue Newton Centre, Mass.



HELLO, BOYS, won't you go fishing with me and my three brothers, at my Dad's camp this summer? It is

### WAWBEWAWA

The Canoeing Camp for Boys  
On Squam Lake at Ashland, N. H.

We'll go on lots of canoe trips and camping-out trips, instead of just loafing around camp and playing games. We'll learn how to follow a trail through the woods and up mountains; to build a cooking fire and mix a "twist" and toss "zap-jacks"; to paddle a canoe for fishing and cruising and racing and "stunts"; to make a browse bed and sleep rolled up in a blanket under the stars; and we'll know how to

hold up our heads and look the other fellows in the eye.



Don't forget Dad's address is

DR. JOHN B. MAY, Director, Cohasset, Mass.

## Temple Camp for Boys

at Beaverkill, N. Y. Altitude 1700 ft. Ages 10-15. Boxing, wrestling, swimming, tennis, baseball, golf, hikes. Careful supervision. Number limited to 25. Reference: Mrs. H. L. Roosevelt, 80 Madison Ave., N. Y. City. Write for booklet.

C. R. TEMPLE, *Director*

825 Madison Ave.

New York City

## Summer Camps for Boys and Girls

### CAMP VARUNA

for LITTLE FOLKS; 3-12

Everything to make a healthful and happy summer. Land, water sports, gardening, toy making, basketry, weaving, modeling, aesthetic and folk dancing.

20 Miles from New York.

LORA M. WARNER

Riverdale Park

MAMARONECK :: NEW YORK

ILLINOIS, St. Charles.

### ORCHARD HILL CAMPS

on the beautiful Fox River, forty miles west of Chicago. Companion camps for boys and girls from three to fourteen. Boys' camp directed by Dr. Richard J. Lambert assisted by experienced scout master. Girls' camp under the personal direction of Dr. Edith B. Lowry. Write

ORCHARD HILL CAMPS, St. Charles, Ill.

**A Mother** of two healthy, well-trained kiddies offers your little ones a wonderful summer in her camp on a beautiful mountain top near the Catskills. Pony and pets, picnics, swimming, arts and crafts. \$240 For twelve weeks. MRS. C. G. WRIGHT, Box 75, Ambler, Pa.

## LIVE OUTDOORS!

WE believe so thoroughly in the great tonic of sunshine and fresh air, that we take this opportunity to urge upon parents the use of St. Nicholas Camp Department—the Gateway to a summer in the open for boys and girls.

Inquiries receive our most careful attention. We try to fit camps to your individual requirements.

Address

ST. NICHOLAS CAMP SERVICE DEPARTMENT

St. Nicholas Magazine

353 FOURTH AVENUE, NEW YORK CITY

**CAMP FIRE ISLAND** (Long Island, N.Y.) Ideal Summer Camp for Boys and Girls (reservations for grown-ups). Rates: season, \$20.00 weekly; shorter periods, \$25.00, including excellent board. Surf and bay bathing, fishing, boating and other activities. Railroad fare \$1.91 from New York. For booklet, write OCEAN BAY CO., 111 West 42nd Street, New York. Phone Bryant 6280.

## Advertisements in ST. NICHOLAS

always indicate **QUALITY**

NO man is going to place his name or his trademark on the product he manufactures unless he has reason to know that his goods are just a little better than unidentified products. You can depend on the *quality* of the goods advertised in these pages.



# GOOD SCHOOLS

FOR  
BOYS *and* GIRLS

BOYS

GIRLS



## COLUMBIA PREPARATORY SCHOOL

Preparation For  
All Colleges and Universities  
Sponsored by University Presidents  
Patronized by University Faculties  
Member University of State of New York

DAY AND RESIDENT — PRIMARY TO COLLEGE

COMBINING THE MOST PROGRESSIVE METHODS OF EDUCATION  
WITH THE CULTURAL ADVANTAGES OF NEW YORK

Ideal home life for refined, cultured girls and boys of all ages, under an experienced faculty composed of Europe and America's Most Eminent Teachers who are masters in social and academic training.

Separate departments for Art, Music, Dramatic Art and Junior Division

DR. C. CLAWSON, *Principal*, 301 West 88th St., Cor. West End Avenue, New York



## The Hedges

NORTON, MASS.

The Junior School of **House in the Pines**. 30 Miles from Boston. For girls under fourteen. A large modern home. Sun parlors for class rooms. Play fields. Horseback riding. Swimming. A wholesome, simple life of study and play that makes the child quick to feel, eager to know, able to do.

MISS GERTRUDE E. CORNISH, *Principal*



## PAGE MILITARY ACADEMY

A big school for little boys (as young as six but not over fourteen) where the little fellows get home care and training. Your boy will be safe here while he learns worth-while things. Sympathetic, intelligent guidance everywhere. Military training, modified to meet boys' needs, makes alert, erect and prompt. Let Page start your boy so he will go right. Lady teachers to fifth grade. House Mothers. Ask for the Page catalog. Address

ROBERT A. GIBBS, *Headmaster*

Route 7, Box 947  
LOS ANGELES CALIFORNIA

# TENACRE

*A Country School for Young Girls  
from Ten to Fourteen Years of Age*



*Riding  
Class at  
TENACRE*

**P**REPARATORY to Dana Hall. Fourteen miles from Boston. All sports and athletics supervised and adapted to the age of the pupil. The finest instruction, care and influence.

MISS HELEN TEMPLE COOKE  
Dana Hall, Wellesley, Mass.

## The Castle

Junior Department of Miss Mason's School

For the little girl who wants a school like older sisters. Work and play directed for the steady development of the child from 6 - 12 years of age. Unsurpassed advantages. Near New York City. Rate \$1000. Catalog.

Miss C. E. MASON, *Principal*  
Box 725, Tarrytown-on-Hudson, N. Y.



## Stamford Military Academy

A preparatory school that pursues sound educational methods and provides a thorough training for mind and body. Located in the beautiful hill country of Connecticut, convenient to New York, the situation is ideal.

Every power is bent toward the complete development of each student. Classes are purposely small and boys are assured individual consideration from every teacher. Instructors are chosen for their moral force as well as for their skill.

The locality permits every kind of outdoor sport and the gymnasium is well equipped for all indoor exercise. Summer Camp. For catalog, address

WALTER D. GERKEN, A.M., *Principal*  
New Canaan, Connecticut



## Lincoln School

A school for girls, offering country life with the advantages of the city. Preparation for college examinations, and general courses. Exceptional opportunity for outdoor sports. Horseback riding.

Miss Miriam Sewall Converse, *Principal*  
Providence, Rhode Island

CONNECTICUT, Cornwall.

## RUMSEY HALL

A School for Boys under 15. Yearly rate \$1300.

L. R. SANFORD, *Principal*.  
LOUIS H. SCHUTTE, M.A., *Headmaster*.

NEW JERSEY, Orange.

## MISS BEARD'S SCHOOL FOR GIRLS

A country school, 13 miles from New York. College preparatory, special courses, Music, Art, Domestic Science. Supervised physical work in gymnasium and field. Catalog on request.

LUCIE C. BEARD, *Headmistress*.

## LA PRINTANIÈRE

A real French vacation for your girls in America. An ideal spot in the exclusive suburb of Great Neck, Long Island.

Mademoiselle André Frontiny will take a limited number of girls from seven to fifteen years of age, who desire to learn French without effort in an entirely French atmosphere. For nine weeks, beginning July 1st. Price \$125.00.

26 7th Street

Great Neck, Long Island



# BINGHAM SCHOOL, MEBANE, N. C.

ESTABLISHED 1793

AN IDEAL BOYS SCHOOL IN PIEDMONT NORTH CAROLINA

HERE, at Bingham, the spirit of old-time Southern hospitality makes each boy genuinely welcomed. Military organization, begun in 1861. High moral tone. Lovely lawns. Gymnasium. Athletic park. Bible and Physical culture emphasized. Honor System. Celebrated climate. Outdoor classes. Limited numbers. Sports in variety. 340 acres. Summer camp. A modern school with an ancient name, fame and history. Send for catalogue.

COL. PRESTON LEWIS GRAY, *President*, Box 8, Mebane, N. C.

## Ossining School

### FOR GIRLS

We offer, with diploma, Academic, College Preparatory, Art, Music, Dramatic, Secretarial and Home-making Courses, including Horticulture.

Students may enter regular courses or, with parents' approval, may specialize as desired. In beautiful Westchester, 30 miles from New York. 54th year. Write for Year Book. Address Ossining-on-Hudson, New York. Box 103.

CLARA C. FULLER, *Principal*

## Miss Hall's

### SCHOOL FOR GIRLS

In the Berkshire Hills, on the Holmes Road to Lenox. Forty-five acres. One thousand feet above the sea level.

Miss MIRA H. HALL, *Principal*  
Pittsfield, Massachusetts



## RYDAL

### Junior Department of the Ogontz School

A fifteen acre private estate on the Rydal Hills is the home of the Rydal School, for girls 9-14 years. Same management as Ogontz School, but a separate school in buildings, faculty, work and play. Parents will find at Rydal the same unusual opportunities that make the Ogontz School distinctive. Teacher of strong personality and experience in charge. Enrollment limited. Visit the school or write for book of views and "Letter to Mothers." Address

Miss Abby A. Sutherland, Rydal, Montgomery Co., Pa.

MASSACHUSETTS, Berkshire.

## CRESTALBAN

A school for little girls in the invigorating climate of the Berkshires. Thirty minutes from Pittsfield. 200 acres, 3 buildings. Number limited. Special care given to home training, character development, and health. Open-air classes. Outdoor sports.

Miss MARGERY WHITING, *Principal*.

MASSACHUSETTS, Bradford.

## JUNIOR BRADFORD

A preparatory school for Bradford Academy. Directed study and play. Arts and crafts. All advantages of Bradford Academy equipment. For Booklets, address THE PRINCIPAL, 139 Main Street, Bradford, Mass.

PENNSYLVANIA, Swarthmore.

## THE MARY LYON SCHOOL

A Country School in a College Town Preparatory for college. High scholastic standards. Music, Art, Languages, Home-making Sciences. Outdoor sports including canoeing. SEVEN GABLES—Junior School. WILDCLIFF—Graduate School. Write for catalogs.

Mr. and Mrs. H. M. CRIST, *Principals*,  
Box 1542, Swarthmore, Pa.

MARYLAND, Baltimore.

## THE ROBERTS-BEACH SCHOOL

Offers a strong college preparatory course for girls. Limited numbers with close individual instruction. Attractive home in beautiful suburban Baltimore. Catalog. Address Box 900, Catonsville, Md.

## Whiting

## Hall

### A Country Home School for Girls

from eight to sixteen, affiliated with the best preparatory schools. Twenty-six acres, modern buildings, new gymnasium, ideal location, high elevation—halfway between Boston and Worcester, near Longfellow's Wayside Inn. Outdoor sleeping and class rooms, if desired. Individual care. Teachers for all branches. Mistress of field games. House mother. Family life emphasized. Tenth year.

MR. ELBRIDGE C. WHITING, Amherst, Yale, MRS. WHITING, Wellesley, Prins. CONCORD ROAD, SOUTH SUDBURY, MASS.

## WOODLAND PARK Junior School of Lasell Seminary

Prepares for Lasell Seminary and other leading secondary schools. Careful direction under House Mother. Progressive methods of study and play. All the equipment of Lasell Seminary, with playgrounds, gymnasium and swimming pool. 15 Buildings. 30 Acres.

*Camp Teconnet opens July 1st*

Guy M. Winslow, Ph.D., Principal Chas. F. Towne, A.M., Associate Principal  
Woodland Road, Auburndale, Mass.



250 Alert Boys 22 Competent Men  
\$800,000 Equipment  
89th year opens September 19th

## WORCESTER ACADEMY

WORCESTER MASSACHUSETTS

Rates: \$1000 single  
\$850 double

Junior School for young boys

For catalog address the Registrar, G. D. Church, M.A.

SAMUEL F. HOLMES, M.A., Principal



## DUMMER ACADEMY

SOUTH BYFIELD, MASS.

160th Year. 35 Miles from Boston. 370 Acres for sports and life in the open. Athletic field, golf course, tennis court, hockey pond, salt water sports. Separate building and school for boys from 10 to 14. Play and school life carefully planned according to the needs of each boy. Infirmary. For catalogue, address

CHARLES S. INGHAM, Ph.D.

RHODE ISLAND, Providence.

## THE MARY C. WHEELER SCHOOL

*A Town and Country School for Girls*

College preparatory and General Course, Advanced Studio classes. Music. Secretarial Course. Farm Home for girls 10 to 14 years.

## BEGINNING A CAREER

The utmost care should be taken by parents in selecting just the right school at the very beginning of their children's education.

If a mistake is made it requires years of diligent study to overcome it, and sometimes it is never corrected entirely. ST. NICHOLAS has been closely connected for a long number of years with private schools throughout the United States. This association has placed ST. NICHOLAS in a position to properly advise parents in this regard. Information about any school or camp may be obtained by ST. NICHOLAS readers without charge.

Wise parents will begin now to make their plans for the next school term. Address,

SCHOOL SERVICE DEPARTMENT

St. Nicholas Magazine

353 Fourth Avenue :: New York City

## WILLISTON

JUNIOR SCHOOL

*For Young Boys*

Organized to develop the entire boy. Thorough work and graded athletics. Prepares for all leading preparatory schools. Home care, under House-mother, Head-master, and Special Faculty.

Rate \$700

Senior School prepares for college and scientific schools. A progressive school with 80 years of solid achievement behind it.

ARCHIBALD V. GALBRAITH, Principal  
Box N, Easthampton, Mass.



## Southfield Point Hall

A School for Girls. Beautifully situated on Long Island Sound at Southfield Point. Intermediate, general, and college preparatory courses. Music, gymnastics, athletics, and sports. Horseback riding, skating, skiing. 52 minutes from Grand Central Station, New York. Limited enrollment.

JESSIE CALLAM GRAY, B. A., Principal  
BERNICE TOWNSEND PORTER, Assistant Principal  
10 Davenport Drive, Stamford, Conn.



"The Blue Circle" Will Fascinate You

# THE BLUE CIRCLE

By ELIZABETH JORDAN

Author of "The Girl in the Mirror," etc.

THIS is one of the most original and breathlessly exciting love and mystery stories we have published in recent years. And it is beautifully told.

For very special and entirely adequate reasons, young Renshaw sells himself for a year and enters a house of mystery in the country. It is a huge house of luxurious ease, but teasingly fascinating unexplained things begin happening just as soon as he is admitted into his employer's family circle there. What happens there is the story and—and—well, we must not tell any more. "The Blue Circle" we heartily recommend. *Illustrated. Price \$1.90*



# THE TRUTH ABOUT VIGNOLLES

By ALBERT KINROSS

HERE are six stories, all written around the same central character but in different settings, in England, Mesopotamia, in Cairo and other parts of the Near East. All the stories are of a feel and flavor, of a richness and variety quite extraordinary. It is fiction that captures the imagination of the reader, that gives his intelligence something to work on, that stimulates his emotion and enlarges his horizon. Mr. Kinross reveals a keen, sophisticated, humorous adult personality it is good to come in contact with.

*Illustrated. Price \$1.90*

## MORE JATAKA TALES

By ELLEN C. BABBITT

More of those delightful folk tales from the land of "Kim" and "The Jungle Book." 33 silhouette illustrations.

*Price \$1.25*

## SHOE-BAR STRATTON

By JOSEPH B. AMES

A STORY of love and adventure set in the Western cow country, which is nowadays adding to its perennial lure the prospect of sudden dazzling fortune through oil wells. Mr. Ames transports his readers to the great open spaces with their far horizons and plunges them into the thrilling battle a plucky girl is waging for what she believes is her property.

*Illustrated. Price \$1.75*

At All Bookstores  
Published by

**THE CENTURY CO.**

353 Fourth Avenue  
New York City

## The First Book Ever Done On the Laurentians

**T**HIS mysterious wonderland of the North, only thirty-six hours from New York City, is as foreign as France and as wild as in the days of Jacques Cartier and offers interests of infinite variety.



# THE LAURENTIANS

By T. M. LONGSTRETH

**A** DELIGHTFUL combination of travel, adventure and guide-book. It taps a new and inexhaustible land either for the tourist who would merely voyage in comfort up the Saguenay, for the canoeist on the lookout for new routes, for the well-read who have romance in their veins and cannot afford a trip to Normandy, or for the man who does not care to read and yet wants information on new hunting lands. It is preëminently for the person who, whether he is to visit foreign lands or not, likes to read about them and about the author's adventures in them.

Mr. Longstreth spent some time with the Chapdelaine family which appears in Louis Hemon's famous novel, "Maria Chapdelaine."

*Illustrated. Price \$3.50*

Also By Mr. Longstreth

## THE CATSKILLS

**F**OLLOWING his popular method, the author has produced another of his delightful and useful combinations of travel and guide books on that mountain playground nearest New York City, the Catskills. This is the region that John Burroughs loved so loyally and whose praises he sang for so many years. It is the land of Rip Van Winkle, the recreation ground for innumerable vacationists.

*Illustrated. Price \$3.50*

## THE ADIRONDACKS

**T**AKING with him a congenial companion, Mr. Longstreth wandered over the great Adirondack country; and his book is a charming record in the mood of Stevenson of, the adventures of two travelers in that vast natural park. Incidentally, he gives all manner of information about roads, hotels, clubs, etc. In this, as in all his books, the author brings to the reader the very feel of the great out-of-doors.

*Illustrated. Price \$3.50*

At All Bookstores  
Published by

**THE CENTURY CO.**

353 Fourth Avenue  
New York City



# Outdoor Books for Boys and Girls

## BOY HUNTERS OF DEMERARA

By GEORGE INNESS HARTLEY

ONE of the best combined natural history and adventure stories which has been published for years. The wonders of a region strange to most of us—the jungle of British Guiana, with its strikingly unfamiliar and interesting wild life and its Indians scarcely touched by the white man's civilization, are described through the medium of a stirring story about a young naturalist sent to collect specimens for a museum, and his still younger assistants.

*Illustrated. Price \$1.75*

## TORRANCE FROM TEXAS

By JOSEPH B. AMES

Author of "Curly of the Circle Bar," etc.

MR. AMES knows how to give boys exactly the sort of story they like best. He tells here of a Texas boy who, accustomed to the freedoms, manly tasks, rough courage and physical expertness of outdoor life, arrives at a New England school with every intention of dominating it. He discovers values he has never suspected and finds himself not a leader but often a good deal at a loss, at first,

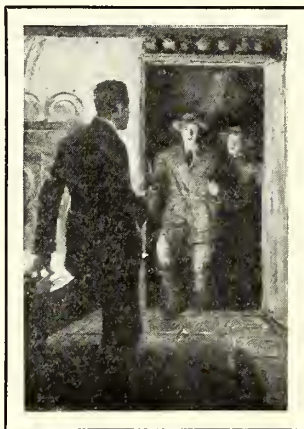

in the strange surroundings. The story of how he found himself at last in the new environment will interest every boy, as will the lively adventures which are a part of his experiences.

After the school has gone into camp at Loon Lake, there is the added thrill of mystery on every page—for there is a "haunted house" with a tantalizing mystery which requires the attention of the boys—and receives it to startlingly good purpose.

*Illustrated. Price \$1.75*

## TINY TOILERS AND THEIR WORKS

By GRAVES GLENWOOD CLARK

ATTRACTIVE, brightly told and fascinating stories of some of the more spectacular and little-known activities of insects—the Texan agricultural ant who raises a crop; the young tarantula who never gets hungry; the strange spinning of the psyche moth, etc. The information is accurate and the treatment makes it as exciting as a fairy tale. New kinds of heroes, heroines, clowns and villains appear in an insect world whose laws and customs are as interesting as they are captivatingly strange.

*Illustrated. Price \$1.75*

At All Bookstores  
Published by

**THE CENTURY CO.**

353 Fourth Avenue  
New York City

*It's Ten to One You Are*  
*Healthier Than You Think*

# OUTWITTING OUR NERVES

By

JACKSON, M.D., and SALISBURY

**T**HE most cheerful, the most readable, the most helpful, the most successful, the most enthusiastically endorsed book on better health that has been published in years. Doctors are prescribing it. The reviewing press has given columns to both the authoritative subject matter and the delightful style of the book.

It does not indulge in vain platitudes about worry and will power; it shows the real reason for worry and the blues. There are chapters on the Subconscious Mind, The Real Trouble, The Way Out, That Tired Feeling, Dietary Taboos, The Bugaboo of Constipation, Insomnia, Woman's Handicap, and others equally vital. Some of these chapters will revolutionize the habits of a life-time.

A great part of all disease is functional: organic disease is far less common. Functional diseases are curable and it is the great discovery of psychoanalysis that they are often removed by just understanding their nature and gaining a right mental attitude. "Outwitting Our Nerves" is an invaluable aid to the achievement of such an attitude. It reveals how many kinds of disease can result from mistaken mental attitudes; tells how not to be sick when there is no real reason for staying sick; how to face your difficulties, know what they are and how to deal with them; how to live, fully, bravely, happily.

*33rd thousand. Price \$2.50*

## *Press Comments:*

**The New York Evening Post:** There is not a shimmer of a doubt but that one-half the people in the United States could read this volume with profit.

**Boston Transcript:** It is a particularly practical book, certain of being useful to large numbers of people.

**The New York Times** (In a page review by Van Buren Thorne, M.D.): Contains explanations of the Freudian principles in their simplest form and is therefore invaluable to those whose knowledge of them is vague or confused.

**Pittsburgh Dispatch:** It is written in an admirable style, never ponderous, but as bright as the cheerful message it brings.

**Boston Herald:** Not just another book about a new kind of treatment, not just another psychic book, but a book of good sense, good reading and good medicine.

**Baltimore Evening Sun:** A scientific book, but its authors have the knack, which was so wonderfully developed by Professor William James, of putting the truths of science into clear, epigrammatic, idiomatic English.

**Buffalo Commercial:** We may thank the authors for the clear manner in which they have explained much that has to do with the discoveries of Freud.

At All Bookstores  
Published by

**THE CENTURY CO.**

353 Fourth Avenue  
New York City



## More New Books for Boys and Girls

# ANIMAL LIFE IN FIELD AND GARDEN

By JEAN-HENRI FABRE

THE most charming of writers on natural history tells his two nephews stories about the animals, birds and insects whose life-habits affect the crops of field and garden and orchard. He surprises them by showing them that many of those little creatures we have always scorned or feared are our very powerful, and even much-needed, friends. *Illustrated. Price \$2.50*

# GOLF FACTS FOR YOUNG PEOPLE

By FRANCIS OUMET

THE "veteran" golfer, who has been amateur champion, victor in many hard-played matches, and is just as keen and expert a player as ever, gives to young people the advantage of his golf-wisdom, and the results of much observation, many friendships and wide contacts with the great game. He himself began golf young on an improvised course, and he understands the problems of youthful players: the pitfalls to be avoided, the difficulties under which they must sometimes develop their game.

*Illustrated. Price \$1.75*

# BROTHER ESKIMO

By ALAN SULLIVAN

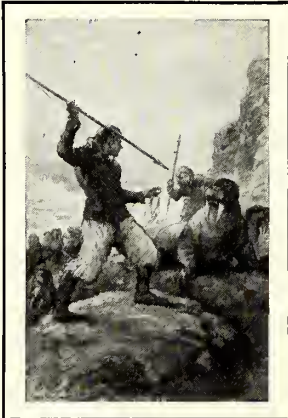

"A YOUNG Mowgli of the North," a professional reader called the hero of this book. He is carried away in his father's igloo on the ice-floe, far from any place he knows, with only his younger brother for companion. The strange life of the north, every condition of which is strange as dreamland to us, Mr. Sullivan knows well and describes accurately and fascinatingly. The two boys go through many adventures, in which wild animals play a large part, life itself depending upon their knowledge of the arctic creatures.

*Illustrated. Price \$1.75*

# THE BOYS' BOOK OF MODEL AEROPLANES

By FRANCIS A. COLLINS

AN up-to-date new book covering all of the phases of young people's interest in the art and science of the aeroplane, including clubs, tournaments, prizes, etc., and giving models, discussion of principles, building and flying instructions, and photographs of actual planes of all types, often with their young builders and flyers. This supersedes two earlier boys' books of model aeroplanes by Mr. Collins. *Illustrated. Price \$2.00*

At All Bookstores  
Published by

THE CENTURY CO.

353 Fourth Avenue  
New York City







“PLEASE!—IF YOU WILL LET ME, I THINK I CAN HELP!” (SEE PAGE 808)

# ST. NICHOLAS

VOL. XLIX

JUNE, 1922

No. 8

Copyright, 1922, by THE CENTURY CO. All rights reserved.

## JIMMY DODD PLAYS MIXED DOUBLES

By CORNELIUS BRETT BOOCOCK

"WELL," said the chairman, as he glanced around the table where the tennis committee was seated, "we are short a man. In my many years at Westfall I have never known such a scarcity of men. Here we are, a day before the tournament, and we have more girls than we need."

The committee had assembled to make the drawings for the annual mixed-doubles tournament. This feature of the club, following the championship tournaments for both men and women, had always been popular at Westfall. Contrary to custom, partners were chosen by lot, which did not permit the best players to pair off together, but tended to equalize the difference in ability by having the better players play with those who were not so good. This naturally added interest. But it did not always follow that good teams were not made, as they often were, but it eliminated any foregone conclusions as to who the victors would be.

This year the committee was embarrassed because they could not supply a partner for every woman who had entered, and it began to appear that some one would be denied the chance to compete.

That afternoon, Harvey Faulks, an active member of the summer colony, who sported the tennis insignia of one of our eastern universities, had just finished a set of doubles, and as he hurdled the rail of the club-house

veranda on his way to the ice-cooler, remarked, "One more set, and I 'll feel like a swim."

No one appeared to provide the set for him, and he was on his way to his roadster when Jimmy Dodd, a boy of thirteen, approached him. "I 'll play with you, Harvey," he said bashfully; "but I 'm not much good."

Faulks was about to thank him and decline, when he noticed an eager look in his young friend's eye; and although he knew that a set with him would not prove too exciting, he hated to disappoint him, so he said, "That 's good of you, Jimmy, but you must promise not to beat me too badly."

Now this was the opportunity that Jimmy Dodd had long awaited. He was a great admirer of Faulks, who had always taken an interest in the younger boys, and he had always wanted to play him. Not that he thought he could win, but he realized that his own game might profit by strong opposition. For a boy of his years, Jimmy was an exceptionally good player. His father had played with him and coached him ever since he had been old enough to hold a racket. His father knew a lot about tennis, too, and in his younger days had ranked with the best. "Never miss," he had told his son time and again. "When you put the ball in the other fellow's court you give him a



chance to miss; and the person who misses the least usually wins." But Jim's training had not stopped there, but had gone on. He played in beautiful form, and his game, although not possessing the speed of an older person, showed no weakness.

Faulks gave his youthful opponent choice of both court and service. Jimmy served. The first ball he hit in the left corner of the court on Faulks' backhand. This Harvey returned with an easy stroke, only to have it smashed to the other side of the court by Jimmy, who had followed his serve to the net. "Good shot!" Faulks called, as he prepared to receive in the other court.

Again the ball came on his backhand; and as he saw that Jim was again coming to the net, he stroked it sharply, but not accurately, and it went out. The next point resulted in a long rally from the base-line, and was finally concluded when Faulks dashed to the net, only to have a well-placed lob float over his head. A bit flustered, he netted the next shot, and the first game went to Jimmy.

Starting to serve, Faulks put all his speed into it; but Jimmy had played with his father many times, and speed alone presented no insurmountable difficulty and he met each ball with his beautifully executed shots. Faulks came to the net to kill the returns, only to have the ball whiz by him or pass over his head. He gained but two points in this game. Now, completely rattled, he lost the third.

Harvey Faulks was an experienced player. He had competed in many tournaments and was considered among the best in college circles. The loss of the third game somewhat cleared his head, and he realized that nothing but A-1 tennis could beat this youngster who never missed a ball. So he settled down, and, by playing for all that he was worth, finally won the set, only losing one more game. When he left the court he was perspiring freely and felt truly ready for a swim.

"Jimmy," he said, as he was putting his racket away, "you had me running. I did n't know that you played such a good game. How would you like to play in the tournament to-morrow? We are short a man and I'd be glad to enter you."

"That would be great," the boy answered smilingly; "but do you think I'm old enough?"

That evening the committee assembled again to make the drawings. As soon as they had been called to order, Faulks, ad-

ressing the chairman, said, "Mr. Cramer, I have the extra man for you."

"That 's fine, Harvey," was the pleased answer. "Who is it?"

Smiling a little, Faulks said, "Jimmy Dodd."

"Jimmy Dodd!" Cramer replied disappointedly, "why, he 's already entered."

"But I mean young Jimmy," Faulks returned.

"Well now, that 's too bad!" said Mr. Cramer. "I 'm afraid he can't play; he 's nothing but a kid."

"That 's what I thought until this afternoon," Faulks said; "but I 've changed my mind. You know, gentlemen," he said, speaking to the others in the room, "we don't pay enough attention to the kids. We often look upon them as a nuisance, and rarely notice them unless it is to put them off the courts."

He then related his experience of the afternoon, and Jimmy was duly entered.

Among the summer residents of Westfall was a lady by the name of Miss Jackson, who for several years had won the ladies' championship. For some reason or other she was not liked, and so could hardly be termed a popular champion. She felt this and was constantly on her guard lest she be denied some of the privileges that were her due. All of the men knew that to draw her for a partner would, in all probability, insure the tournament for them, but all hoped that they would not have such good luck.

So when Mr. Cramer drew her name from the hat, the others waited interestedly to learn who would be paired with her. Putting his hand into another hat, he solemnly drew forth a slip of paper. Unfolding it, he announced, "James Dodd, Junior."

Faulks was on his feet. "Mr. Chairman, I protest. It is n't fair to make that boy play with Miss Jackson. She would n't see the humor in it, and it would only make it disagreeable for him."

"That may be so," replied the chairman, "but the principle of this tournament is a choice of partners by lot, and we can't make any exceptions. I'm sorry."

The next morning the crowd gathered early, and, as soon as the list was posted, all sought to find their names.

"Can you beat it? I drew Agnes Domly," said one, cheerfully, "I was just hoping for that."

"You 're in luck, all right," replied his companion, "and I'm not. I have to play



"WELL! OF ALL THINGS! DO THEY REALLY EXPECT ME TO PLAY WITH THE KINDERGARTEN?"

with that old war-ship." Such were the remarks that flew about.

They were all interested in their own affairs, so Jimmy, as he quietly looked over the board, was not noticed. When he read that he would have to play with the formidable Miss Jackson, his heart fell and he wandered off by himself to an unfrequented corner.

"I wish I had n't entered the old tournament!" he said half aloud.

But Jimmy was a little shy, and perhaps this accounted for his reticence. Nevertheless, the thought of quitting never occurred to him.

As Miss Jackson approached the clubhouse it was noticed that she had drawn Jimmy as a partner. The thought of that team caused a lot of amusement; but as Miss Jackson walked up to the board, most of the people withdrew to a respectful distance, because they foresaw fireworks.

She strode majestically up to the board and found her name.

"James Dodd," she was heard to say; "that could be worse."

While this was going on, Faulks had taken Jimmy from his secluded corner and had been coaching him how to approach Miss Jackson. When he thought the psychological moment had arrived he sent Jimmy up to her.

"Good morning, Miss Jackson," he began, as instructed; "I believe I am so fortunate as to have drawn you as a partner. Our opponents are ready, and, if you care to, we might start."

Now Harvey Faulks had learned at college that "a soft answer turneth away wrath." And it often does. But the circumstances were not right for it this time, and the fireworks that were expected were not long in coming.



She turned on the boy. "Well! Of all things! Do they really expect me to play with the kindergarten? I have never heard the equal to this! Where's the committee?"

She caught sight of Harvey and stormed up to him. "What is this—a practical joke, or something? Am I to be nurse-maid while I play?"

To this, Harvey replied as politely as his rising anger would permit that she would have to play with Jimmy, and congratulated her on having "the best little sport in the community" as her partner.

All this was, of course, very unpleasant to Jimmy, who, not wishing to hear more, started to leave. He walked slowly with his head bent and really made a very pathetic sight. It made the other people who were there even more bitter against Miss Jackson than they had been before.

She saw in this a deliberate attempt to embarrass her. And perhaps she was justified, for it was not the custom at Westfall to have the younger boys take part in the senior tournaments. She was disappointed, as she had hoped to have one of the better players as her partner. But she was a fighter by instinct, else she would not have won many of her matches; so she took her racket out of the case and determined to win even if she were handicapped by a juvenile partner.

She had never seen Jimmy play, so far as she could remember, and thought, of course, that he knew little or nothing about the game. "Now, young man," she said, in a domineering way, when they were ready to play, "when you are not actually serving or receiving, stand here," indicating a far corner of the court.

Play started, and spurred on by the imagined insult to herself, Miss Jackson played a fine game, surprising her opponents and perhaps herself with the excellence of her shots. Jimmy, as commanded, did n't stir, but he did n't miss any of the chances that he was required by the laws of doubles to take. Miss Jackson noticed this, but attributed it to luck rather than to skill.

After winning the first set, Miss Jackson began to tire, and, do what she could, the other pair won the second set. All this was torture to Jimmy. He saw easy shots missed, that he could have handled, and he saw his partner wearing herself out trying to cover his side of the court as well as her own. At the beginning of the third set he had decided that the captaincy of the Jack-

son-Dodd pair should change hands before defeat was upon them.

"Now, Miss Jackson," said he, as fiercely as a boy of thirteen could say it, "I'm going to play!"

"Don't you move from that corner," was her reply. She was really angry, by now, and tired too.

On the very next shot he did move from his corner, and was just in the act of hitting the ball when his partner dashed in front of him and literally took the shot from his racket. But he had started his swing, and, either by accident or intent, completed it and hit, not the ball, as you may guess, but his charming partner.

An explosion resulted, as he expected, but he held his ground, remarking that the same thing might happen again. The result was that the Jackson-Dodd team began to play good mixed doubles and handily won the third set. Jimmy, once he got in the game, played as though his life depended upon it. At the net he was sure and crafty, while his strokes possessed the necessary punch to win points.

When the match was completed, Miss Jackson went off by herself and analyzed the events of the preceding hours. Her first conclusion was that she had made a fool of herself; secondly, her actions would undoubtedly add to her unpopularity; and lastly, that her partner, young though he was, could certainly play tennis and possessed a swift stroke, as a bruise on her shoulder constantly reminded her.

In the next match of the tournament the following day, Miss Jackson recognized her partner as an equal force on the team, and consequently they did well enough to win. But their opposition was not of the strongest. During the two sets that were required, Jimmy came to realize that his partner played beautiful tennis and admired her for it. The day before, he had hated her; but he was quick to recognize merit and soon forgot the unpleasantness that had come up. Miss Jackson experienced a change of heart also. She had thought that he was a "very fresh kid," but it was not long before she saw that in this she had been mistaken. It would be very hard to dislike Jimmy for any length of time, for he possessed a certain quality that drew people to him. Dressed in his white knickerbockers, with his light hair kept from his face by a handkerchief, and playing as an equal with people twice and even thrice his age, he was nothing short

of inspiring. Then, too, his smile was irresistible.

In the semi-finals, they ran up against Mr. Dodd and his partner Mrs. Ferris. It

son did not know this, but the first set had hardly started when he whispered to her, "Soak 'em on Dad's backhand and make 'em low." This flaw in the elder Dodd's game proved the deciding factor in the match, which finally was won in three hard sets by Miss Jackson and Jimmy.

During this match, a real feeling of team play had come to them. Constantly encouraging each other, everything showed good friendship between them. At one time in the third set, when Miss Jackson was serving, the game had gone to deuce several times. Jimmy was at the net, and just before she served he turned around and said, "An ace now, Miss Jackson, old girl!" This had delighted the gallery, and Jimmy beamed when she shot the ball out of his father's reach for a perfect ace.

On the other side of the tournament, Harvey Faulks and Miss Mason were winning. They made a very good team, and as one of the ladies, who knitted as she looked on, remarked, "and a very good-looking couple too!" Which is another story altogether.

On the morning of the finals, a good crowd surrounded the court. There were some, of

course, who were partial, but for the most part they had come to witness tennis for the game's sake. If Jimmy had been paired with any one but Miss Jackson, he would have been the favorite; but he really did n't give it a thought.

Harvey Faulks had a sincere feeling of affection for Jimmy, and for some reasons



"'NOW YOUNG MAN,' SHE SAID, 'YOU STAND HERE!'"

was interesting to have father and son playing against each other, and both seemed to enjoy the encounter. In the many times that Jimmy and Mr. Dodd had played together, the son had discovered that his father could not handle well low balls on his backhand, and consequently the boy placed there all the balls that he could. Miss Jack-



wanted him to win; but he had to consider his partner. He also wanted to make an impression on her, as a cup with their names on it would make a memorable keepsake.

back with all his force, and, covering more court than was his, managed to win the game and set 9-7.

The first set had tired Miss Jackson and Jimmy fell into a slump, so almost before they knew it, the score was five to one against them. At the beginning of the next game, which many thought would be the last, Jimmy called Miss Jackson over to a corner of the court, where they talked earnestly for a minute or two. What they said no one knew, but Jimmy was seen to pound his fist against the strings of his racket, and, before they resumed play, they shook hands.

Jimmy served with the uncanniness of a veteran. First in one corner and then in the other, he would send his shots, mixing fast balls with slow ones and completely bewildering his opponents. Faulks was anxious to finish it off; but when he went to the net the balls went to his partner, and when he stayed back they had an exasperating way of just dropping over.

On Miss Mason's serve, Jimmy and Miss Jackson would return the balls to her deep in the court; and when she returned them, Jimmy would be at the net to finish the

point. The score now stood 5-3, with Faulks serving. This was the crucial game. He had won all his serves, and it did begin to look as if the match were over; but on the first point, he unaccountably served doubles. On the next, Jimmy hooked a shot over Miss Mason's head as she played net, and the ball hit the ground for the second time before Harvey reached it. He then served a clean



"'NOW, MISS JACKSON,' SAID HE, 'I'M GOING TO PLAY!'"

From the very first, play was even. Miss Mason was not as good as Miss Jackson, and Jimmy, good and clever as he was, was not the equal of Harvey, so they were very well balanced. The first set ran along evenly until seven-all was reached. Faulks served the fifteenth game, and, sending one terrific serve after another, won the game. On Miss Jackson's serve, he drove the ball

ace on Miss Jackson, but failed to repeat it against Jimmy, who returned his second serve with a low drive down the side-line. This Harvey returned as he dashed to the net; but his return was a weak lob, which Jimmy smashed. The last point of the game was won after a spirited rally when Miss Jackson neatly passed Harvey.

Nothing seemed to stop Jimmy and his partner. They won the second set 7-5 and had a lead in the third, when their opponents staged a rally. Faulks, by his speed and power, won point after point, and soon had two games tucked away. But with the score 3-2 against them, Jimmy and Miss Jackson braced and brought the score to three-all. The set then became a battle. First one side would forge ahead, and then the other. With the score six-all, Jimmy lost his serve, which almost broke that boy's heart, and when Faulks served, nothing could touch him. The balls would come sizzling over the net, and if a return was possible, it was weak and Harvey was there to smash it.

As he bounced the last ball far out of the court and won the match and tournament, the gallery rose and cheered, not so much for the victors, but for the real tennis treat they had been permitted to see.

While walking to the club-house, Harvey put his hand on Jimmy's shoulder and encouraged him. But this was unnecessary, for Jim, down in his heart, knew that the better team had won. He had done his best and he was satisfied.

Miss Jackson, however, was quite disheartened, and quietly took a chair beside Miss Mason. "I 'd have given anything

to have won that match to-day," she said; "not that I care about it for myself, but for Jimmy. He played as hard as he could, and if only I could have won it, I might have



"MISS JACKSON, WILL YOU BE MY PARTNER?"

atoned for the way I treated him on the first day."

Just then, Jimmy approached with a glass of water. He was hot and flushed, but his smile showed no disappointment.

"Miss Jackson," he said, "there 's a mixed-doubles tournament next week at Shore Road. Will you be my partner?"

## THE HOLLYHOCK FAIRY

By M. D. COLE

THERE 's a sleepy little fairy that lives in hollyhocks;  
 She is waiting for the striking of all the summer clocks.  
 Her little window-blinds are drawn, of yellow, pink, and red,  
 And her little wings are folded around her little head.  
 She is dreaming of the summer and the coming of the bees,  
 Of the warmth within the garden and the blossoms on the trees,  
 Of the butterflies' and moths' wings, and rings to make at night,  
 Of the creepy moon at evening and the golden morning light.  
 She 's a sleepy little fairy, but when thistle clocks strike one,  
 She will wake and pull her curtains—Summer-time will have begun.





"WE WERE JUST OUT OF GYM, WHERE WE HAD BEEN UNUSUALLY STRENUOUS"

## THE PROPER MIXTURE

By ELIZABETH PRICE

WE were just out of gym, where we had been unusually strenuous, and the matter that filled our thoughts fullest of anything, just then, was lunch.

"I'm so starved I could eat cold boiled potatoes!" Patty declared.

Jean laughed. "So could I. In fact, arranged in lettuce leaves with celery and mayonnaise, I could even enjoy them."

"*Could* you? Yum—yum—oh, and onion, just a tiny speck, you know. Bab, what is that poem about salad you were quoting the other day?"

Bab's always quoting poetry. Where she gets time to learn it is a mystery to the rest of us.

"Sydney Smith's recipe," she told Pat. "The lines you want are:

"Let onion atoms lurk within the bowl,  
And, scarce suspected, animate the whole."

"The less suspected, the better for me," I

chimed in. "Girls, here comes Kate Downs with her 'steenth new hat on." Kate really does have more gala rigs than all the rest of us put together. But there's nearly always something about them that does n't appeal to me. I try to keep out of her way when she's newly dolled up, but this time I had no chance.

"Where have you been, girls?" she asked—just as if she'd never heard of gym. "Sure enough—I forgot this was Thursday. I got excused to-day to keep an appointment with the milliner. Tell me—is n't it stylish?"

That's why I try to keep out of Kate's way—the question is sure to come. She looked straight into my eyes when she asked it, and I—well, I simply told the truth. "It's very unbecoming, Kate, if you want me to say what I think."

Of course she turned red. "Indeed, you are mistaken. Madame Blount said it was one of the most 'appropriate chapeaux' she

had introduced this season." Kate held her head for all the world as Madame Blount does when she makes her speeches.

I had to smile—and that did n't help matters any. Our schoolmate stared haughtily, then swept on, withering us with a glance, as the story books say.

"Julia, you are so plain-spoken, dear. Why did you say that?" Jean is gentle and we all love her, but I did n't feel like being called down after they had left me to do the talking, so I said rather crossly, "I notice nobody else told her any different."

"There was n't time—she flounced off so quick after your slap. I don't understand, Julia, why as kind-hearted a girl as you are should say such sharp things."

"That was n't sharp. It was a plain, simple answer to a direct question. I won't tell an untruth for anybody's feelings."

"But, dear, you don't have to tell everything you think, do you?"

"I do—the whole truth and nothing but the truth. I hate deception."

"So I've heard you remark before." Pat's voice was teasing. "Noble sentiment and all that, but a little bit overdone—like an omelet cooked into leather, you know. Kate's hat was pretty—you might have given her the satisfaction of telling her so."

"And helped her to preen like a peacock with those pink roses against her red hair." I tossed my head. "I can do without friendships if I don't suit people, but I will not tell what is n't true."

Jean slipped her arm around my waist. "We would n't have you for anything. She is n't going to get cross with her three old pals."

Nobody can resist Jean, so our near-squabble turned into a laugh, as such things almost always do with us girls.

But I was still thinking about it—sort of an irritating thought it was, too—when I got home. Lunch was ready, but there was no one there, only Mother, so she and I sat down together. I love a little cozy visit with Mother, and I hardly ever do have her by myself. When the troop is home she needs to be about six mothers instead of one, because all of us want her, from Father to Dot. It's true she does divide herself among us in a perfectly wonderful way, and as for taking care of us—well, there are n't any more caretakers like her. Every member of our family could tell you that. But you see what a luxury it was to sit down and have all of her. Even the kitchen was quiet, for Ann

was down in the laundry doing blankets, and it seemed such a gorgeous time for confidences that I told her about meeting Kate Downs and what I'd said and how awful those pink roses looked. "If they'd been blue, Mother—or yellow or green. Anything but those pink ones hanging over the brim on her brick-colored hair. You know things like that always did set my teeth on edge."

"Were the roses pretty, Julia?"

"Oh, of course they were. You never catch Kate Downs wearing common things."

"Was the hat a stylish one?"

"Why, yes, it was; but it did n't look stylish on her. I could n't say it did, could I, Mother? I do have to be truthful, don't I?"

"I sincerely hope so, Julia. But would n't it have been truthful to say the hat was stylish, when that was the question she asked you?"

I looked up curiously. Could it be possible that Mother thought I ought to beat around the bush the way the girls advised me to do?

Just then I heard voices somewhere, and Mother excused herself. In a minute or two she was back. "It's the two men who are shingling the barn," she told me. "I had invited them to bring their lunch into the outside kitchen when they were ready to eat it. Julia, dear, I wonder if they would like some milk? Suppose you take this pitcher out to them—get the tumblers out of the kitchen cupboard."

I'd forgotten Kate, for the minute, when I came back. "They were awfully pleased with the milk. But did you see their spread, Mother?"

"Yes. What of it?"

"Oh, the contrast. One man's lunch looked nice and the other's looked horrid."

"What was the trouble?" Mother's voice was so sort of calm and even I might have known she was n't telling everything she was thinking. But I did n't notice—then. I said:

"How could you help seeing it? Some of the biscuits were so nice and goldy and white, and the others looked dreadful—heavy, and all streaked with brown splotches. Ugh! I'd be afraid they were poison. What do you suppose made 'em like that?"

"Soda—it is n't dangerous," laughed Mother. "Very likely there was soda in the white biscuits, too. Ann often puts it in hers."

"What makes the difference?"

"The ingredients in the streaky ones were not properly mixed, that is all."

"Well, I say it's a shame to ask anybody



to eat such things when they might have been made right." I was very positive about it as I buttered a slice of Ann's good bread and thought about her delicious, feathery biscuits.

"As to that, biscuits are biscuits whether they are inviting or repelling," said Mother.

I laid down my knife and looked at my mother, but she was dressing her salad and did n't raise her eyes. She went on. "If soda is needed, by all means use soda. Only so it gets in, what difference does the process make?"

"Why, Mother! One is a success and the other is a dead failure!"

"But all are biscuits—and contain the same ingredients," she insisted again.

Then a dim light began to leak through to my brain. I kept still while it soaked in, but after awhile I blurted out, "And the truth about Kate's hat being pretty was like the white ones, and the truth about it's being unbecoming is like the streaked ones."

"Oh, do you think so?" Mother acted innocent as a baby lamb.

"I begin to see that you think so," I told her. "Mother, you've always been so particular about us children telling the truth." I think maybe my voice trembled a little bit, for I felt as if somehow I'd lost my way.

She looked at me quickly, then, and she said: "I certainly have been particular. I'd rather we'd lose every friend we possess than to keep them by sacrificing truth. Whatever we say must undoubtedly be true—but, dear, there are many true things which it is n't always wise to say."

"Please tell me what I ought to have said to Kate," I begged.

"Well, Kate asked you if her hat was stylish, and you could with perfect sincerity have answered that it was. If she had pressed the matter farther and wanted your opinion as to it's becomingness, you would certainly have had to state it. But you might have softened even that by saying that you liked blue on her better than pink, or that the hat which she wore with her brown coat was more to your liking."

"Then she'd have gone on feeling satisfied with her pink one," I insisted.

"She probably will, anyway. The only result of your frankness will be the little hurt feeling that she'll keep, I'm afraid, as long as the hat lasts."

"Deary me, how many streaked biscuits I must make!" I sighed. "I told Dick this very morning that his long hair was a dis-

grace to the family, and I suppose I should have told him that his hands were a joy to the family since he'd begun being so careful of them."

"Yes, daughter. And if you had told Matie how well she had tied her hair-ribbon, instead of saying that she was a fright with her front teeth out, it would have been equally true and would have sent her to school happy instead of hurt. For the teeth—and Dick's hair—are Nature's concern, while the hair-ribbon and the manicuring are the children's own."

"Bless 'em—I'll deal out praise with shovel and tongs—see if I don't!"

"Now don't run to the other extreme," laughed Mother. "We should be as sincere in commendation as in fault-finding; for flattery is as hateful as bluntness. Just let me remind you over again, dear, to tell the truth, nothing but the truth, but not necessarily and always the whole truth. Leave out the stings and the pricks when you conscientiously can."

"I'll try. May I take some jam out to the shinglers, Mother? I want one more glimpse of your text."

She smiled in such a funny way that I bounced on her. "You sent me out there on purpose, I do believe!" I said. "You wanted me to see those streaks for myself."

She did n't deny it as I picked up the jam jar. But I was too late, for the biscuit had all disappeared and the men were putting away their lunch-pails. One of them—the men, not the lunch-pails—I noticed was sallow and heavy-eyed and the other looked healthy and happy. Of course, I can't say the biscuits did it—though they looked as if they might. Mother agreed that the careless mixing of even good ingredients might easily cause dyspepsia.

On my way to school I caught up with Kate. When she saw me she lifted her head in a perfectly toploftical way, but I did n't let her know I noticed. I slipped my hand through her arm and I said: "I just love that blue suit on you, Kate. It's so becoming." And the toploftiness melted away like home-made ice-cream.

"Do you think my new hat would look better with blue?" she asked, sort of wistful.

"Personally I do," I told her. "But of course, Katy, it's your hat and if it suits you—"

"It does n't—quite," she owned up. "I like your taste, Julia, lots better than mine."

Now I call that a downright generous com-



"SHE LOOKED STRAIGHT INTO MY EYES, AND I SIMPLY TOLD THE TRUTH"



pliment, for I did n't deserve it one bit. We caught up with Jean and Pat, then, and the way they stared to see Kate chumming with me was funny. But they soon understood, and they are helping me to reform. I do want to mix my ingredients carefully and keep from giving anybody moral dyspepsia—or would you call it mental?

It's much nicer—really it is. My chums are so appreciative—not to mention my family, who almost overwhelm me.

Yesterday Bab said I reminded her of Sydney Smith's onions, and when I flared

up and asked why,—because I should n't usually consider *anybody's* onions a compliment,—she said that I was gradually learning to let my bluntness “animate the whole,” instead of using it in chunks.

“She's even reached the ‘scarce suspected’ stage,” Jean declared. “When she told me to-day that my hair looked lovely yesterday, it took me ten minutes to understand that she was tactfully conveying the information that it looks horrid to-day!”

The girls all laughed—but you see I am getting on.

## MY TREES

THEY do not stand in forest glade  
With moss and fern about their feet;  
Instead, they cast their pleasant shade  
As warders of a village street;

Not theirs the brooding silence deep  
From dawn to dusk, from dark to day—  
They hear the housewives' cheery calls,  
The shouts of children at their play.

But sun and rain are kind to them,  
Their leaves dance with the dancing breeze,  
And through the changes of the years  
I watch and love my neighbor trees.

I thrill with them when spring returns  
To rouse them from their peaceful  
dreams

With some elusive message, borne  
By softer airs and murmuring streams;  
When, through the slowly lengthening days,  
All heedless of the lingering cold,  
The first impatient birds arrive  
With wind-blown feathers, blithe and bold;  
They sing amid the reddening boughs  
And choose the sites for future homes,  
Serenely sure, through snow or sleet  
Or pelting rain, that summer comes.

I joy with them in long, bright days  
When leafy depths with life o'erflow;  
The squirrels race from tree to tree  
And chatter madly as they go.  
Through sultry noons and stifling nights,  
From their cool shade the locust shrills  
His oft-repeated prophecies  
Of heat that blights and drought that kills.  
On one long branch above my roof  
The hang-bird's cradle sways and swings,  
And when the hungry fledglings wake,  
With raucous calls the morning rings;

Then, fluttering down from stair to stair,  
With many a slip and anxious cry,—  
All spotted breasts and stumpy tails,—  
The baby robins learn to fly.

I rest with them when autumn frosts  
Have changed their sober green array  
To gorgeous garments, brief as bright,  
That fade and fall from day to day,  
Revealing, through a thinning veil—  
Mute memories of summer past—  
The small, forsaken homes of song,  
Frail playthings for the winter's blast.  
And when the early darkness comes,  
The moonbeams weave, with elfin grace,  
Across the looms of leafless twigs  
Their magic mesh of shadow-lace.

I hope with them 'neath wintry skies,  
Nor do I feel them sad or chill;  
Austere, but beautiful, they stand  
And read to me a lesson still.  
They patient bide the waiting-time  
Of glory gone and beauty lost,  
Assured that not a leaf shall fall  
And not a bough by storm be tossed,  
Save but as part of God's great plan  
For them and me and all the earth;  
And that a richer, fuller life  
Shall follow on this seeming dearth.

One tells me of the mountain slopes;  
And one, of ocean's myriad moods;  
And one, of some fair mirror-lake  
Enshrined in woodland solitudes.  
My feet may never wander far  
To seek such varied scenes as these,  
But pent, like them, in village streets,  
I am content—I have my trees.

Annie Johnson Flint.

# OVER THE PRECIPICE

By LOUIS ALLEN

THE passage to the cave was so low as to force Wilbur to crawl on hands and knees. At the end of a seventy-foot passage he emerged in one of two high-domed chambers. Many believe that bucaners and pirates visited the Farallones four centuries ago, and a few maintain that Spanish treasure is still buried there.

For years, Wilbur Conrad had pleaded with his father, captain of a sea-going tug operating out of San Francisco, to get a permit from the Lighthouse Department to visit the Farallones. On rare clear days, from the San Francisco cliffs, he had seen these mystic crags, hanging seemingly between sea and sky. These remote, almost inaccessible rocky cliffs rise from the sea about thirty miles west of the Golden Gate. The north Farallones are jagged rock spires pushing a hundred feet above the sea, offering neither anchorage nor landing-place. The Middle Rock is equally inaccessible, and only on the southeast Farallones may one land.

The United States Lighthouse Department communicates with the islands four times a year, other visitors being an occasional tugboat captain who climbs to the vantage of the lighthouse gallery, almost four hundred feet above the sea, to watch for prospective tows.

While Captain Conrad busily scoured the horizon with a binocular in search of a tow, Wilbur, who was fifteen years old, explored the little island. He thrilled at the recollection that Sir Francis Drake, the intrepid English adventurer, landed there in the sixteenth century, many years before the Pilgrims founded Plymouth. In his journal, Drake described the group as isles "wherein are many seals and fowles."

From the cave, Wilbur turned his attention to the sea-fowl, eddying round and round the crags, their nests dotting the seaward slopes of the island on all sides. Most numerous are the murre, with the sea-gulls a close second; next rank the cormorants, with only an occasional auk.

Like the murre and other sea-birds, the cormorants build their nests in clefts and on narrow ledges in the security of sheer cliffs. Wilbur recalled that the egg of the cormorant is highly prized as food, and soon was to

learn that the preference for cormorant's eggs was not exclusively a human tendency.

"I'll bring back a cormorant egg," he determined, half aloud.

To reach a cormorant's nest on the Farallones meant nothing less than taking a chance of slipping on the slimy rocks and plunging to almost certain death at the foot of the cliff.

Working his way up the landward side of the cliff with the aid of a light staff, Wilbur came out on a windy rock platform which he judged to be almost a hundred feet above the sea. Looking down over the dizzying cliff, he could see the long Pacific rollers eddying about half-submerged rocks or surging relentlessly against the fantastically etched rampart. The murre, cormorants, and sea-gulls were in constant motion about the top of the cliff, their nests built in clefts of the rocky wall lower down. He continued along the ridge of the cliff, which gradually sloped downward, until, at a point about forty feet above the sea, he discovered a narrow gallery leading across the crag's face into the midst of the nesting fowl.

As the boy warily picked his way forward over the slimy rocks, where a misstep would send him hurtling to the foot of the cliff, murre and cormorants flew from their nests in alarm, crying shrilly and filling the air with a cloud of flapping wings. For a moment, the sudden upward rush of thousands of sea-fowl terrified Wilbur, who clung to the side of the cliff, undecided whether to push on or turn back. Finally, a commotion just ahead fixed his attention. Several cormorants had left their eggs unprotected, whereupon thieving sea-gulls swooped down upon the abandoned nests, snatched up the eggs, flew aloft, then dropped the eggs, thus smashing their thick shells on the rocks and feasting upon the contents.

Wilbur realized at once that, if he was to secure one of the cormorant eggs, he must act quickly. The narrow shelf became narrower as he proceeded, forcing him to use the utmost care to avoid slipping. Just ahead of him, and not more than ten feet distant, a sea-gull alighted upon a deserted cormorant nest. Impetuously, Wilbur tossed his staff at the intruder. The missile failed to hit the gull, but the clatter frightened the bird from



the nest. Wilbur quickly rescued the sole egg. As he was putting the bulky egg in his pocket a flutter of white wings beat in his face. Frantically he tried to ward off the gull, which had resented the boy's intrusion; but in doing so, he lost his footing on the slimy rocks, plunging feet foremost.

Instinctively, he twisted around in his fall, wildly grasping at the jagged rock wall. Over the edge of the precipice he slipped, scraping along the lower wall, where protruding knife-edged rocks tore his clothing. A moment later he plunged into the boiling surf at the cliff's base.

The cold water quickly brought Wilbur to his senses. Treading water, he managed to pull himself up on a half-submerged rock. For a moment, dazed by his sudden plunge from the cliff, the boy could not account for his position; just as when, waking from a nightmare, he had often racked his brain to get his bearings in his own bedroom.

Looking about him as he clung to his precarious, sea-weed-mantled rock, from which successive waves threatened to hurl him, Wilbur took stock of his position. He had plunged off the beetling crag above, mercifully landing in deep water. At this point the frowning rampart of the island formed a sort of cove. The rock on which he had taken refuge was not more than ten feet from the cliff. Near at hand were other semi-submerged rocks, over which the restless sea swept with every recurring wave.

Slowly the seriousness of his predicament came home to Wilbur. His bruised shins and scratched arms smarted painfully as the salt water worked into the cuts. Occasionally, a wave more powerful than the rest would wrench him from his rock haven. Clutching desperately to the sea-weed, he called out again and again, his voice coming back to him puny and deadened by the constant roar of surf. For several minutes he called for help, then realized the futility of such effort.

"Plainly," he reasoned, "I've got to swim around to the landing-place or find some break in the cliff."

For the life of him, he could not determine whether the landing-place was nearer at hand on the left or the right. He recalled having carelessly studied the map of the island in the tugboat's pilot-house, and now believed that the landing-place was probably at the north end of the island. Over on his right he faintly made out the California coast. Then, noting the position of the sun

and knowing that it must be about three o'clock, he decided that he must be on the southeast side of the island. The boy realized how impossible it would be to swim around the left side of the isle, which would have forced him to battle with the long Pacific rollers. The swim to the right side would take him in the lee of the island—a big advantage, although he had no means of knowing the distance to be covered.

Already the air seemed charged with the cool tang that precedes fog. He gazed seaward, where great fog-banks were forming for their afternoon assault along the California coast. No time could be lost, Wilbur realized, as he removed his soggy boots, trousers, and shirt. With one glance, to see if by any chance a mariner might be hugging close to the island on his way in toward the Golden Gate, Wilbur plunged off his rock refuge and struck out with the breast-stroke toward the eastern side of the island. Though freed of his hampering clothing, he made only slight headway, watching the shore anxiously for any possible openings that would permit of his escape from the sea.

Like a pall, the fog blanket settled over the island, so that in a minute or two Wilbur could not make out the line of a cliff more than thirty feet distant. The dense, smoky air sent a chill through the boy, the fog seeming to increase his sense of loneliness. To add to the oppressiveness of the situation, the monster siren at the seaward end of the island began to sound its lugubrious notes, the unearthly bass sounding in the mysterious fog like the angry roaring of some submarine monster.

For ten minutes he pushed on, gaining the comparative quiet of the leeward side of the island. Scanning the cliff line as well as the fog would permit, he hoped to see some slight break in the frowning wall that might permit of his scaling the cliff to safety. Already the intensely cold water was beginning to slow up his movements.

He had swum about fifteen minutes when he was startled by a splash about twenty feet on his right. It was a large striped bass jumping, evidently pursued by some sea terror. For a moment, panic clutched at Wilbur's heart as visions of sharks rose before him. He had seen these dreaded tigers of the sea brought in at Fisherman's Wharf, the fear then engendered by the monsters never leaving him. Now he believed he was in the midst of man-eaters. Presently, the lone jumping fish was joined by others of his

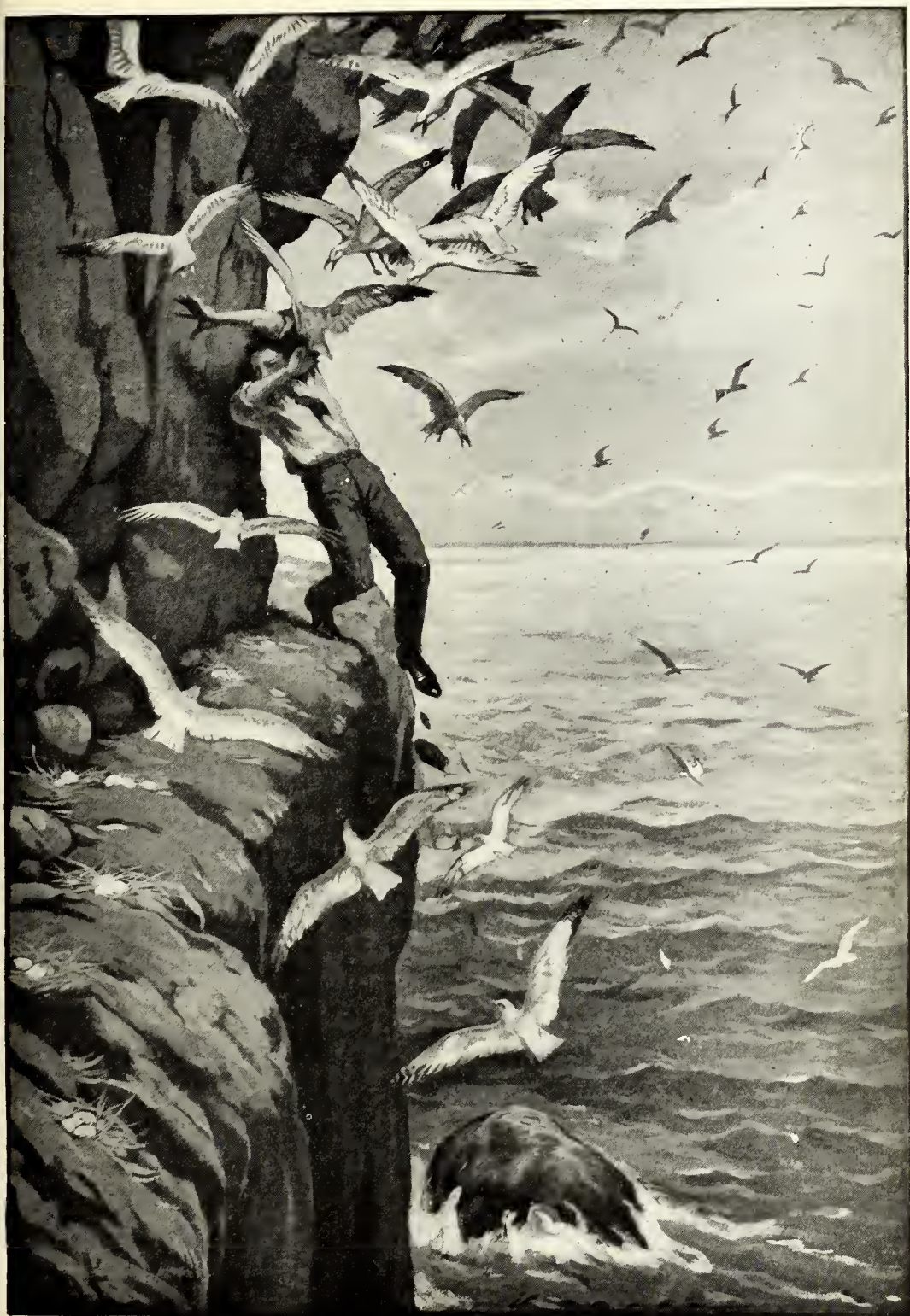

"OVER THE EDGE OF THE PRECIPICE HE SLIPPED"



finny tribe. But if sharks were the mysterious pursuers, they failed to show themselves. Shortly, the leaping fish appeared a mere ripple in the distance, heading toward the Golden Gate.

By this time Wilbur gave up all hope of reaching the landing-place. He knew he had

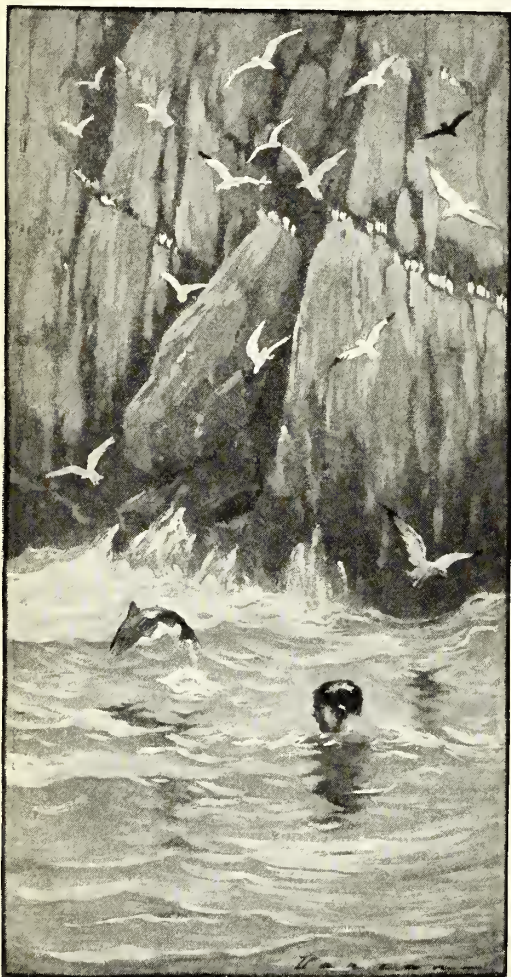

"IT WAS A LARGE STRIPED BASS JUMPING, EVIDENTLY PURSUED BY SOME SEA TERROR"

made some progress northward along the abrupt line of cliff, but he could not be sure whether he had covered an eighth or a quarter of a mile. The icy water had begun to numb his limbs, and the fright caused by the jumping fish had not tended to increase his assurance. From the time when he left his father in the lighthouse early in the afternoon, he had seen no human being nor a sign of human existence, not even a distant sail or steamer.

From the breast-stroke he changed to the trudgeon, which gave him more speed, but less opportunity to watch for an opening in the cliff. From the trudgeon, he would try the back-stroke, then return to the breast-stroke. By this time the boy had become so weak that the stroke changes came at brief intervals. Almost without hope now, he watched the cliff's face slowly drag past. Breathing heavily and with his arms almost numb with exhaustion, he doggedly paddled on within fifteen feet of the cliff, which at this point appeared lower than on the southeast side, although no opening for escape up the abrupt walls had presented itself.

Suddenly he felt a sharp twinge in his left knee. A moment later, a high roller sprawled him almost high and dry on a slightly submerged rock. His knee had crashed against the rock with such force as to paralyze the leg. As he pulled himself into a sitting position, Wilbur realized that he had reached the end of his swimming efforts. His left leg was now useless. He was fifteen feet from the cliff, and as yet no sign of a break in the rampart. About twenty feet ahead the island projected slightly. Wilbur believed that if he was to reach safety at all, it must be around this little cape. To proceed farther along that shore-line with utter exhaustion fast coming on was impossible.

How he traversed the twenty feet between his resting-place and the promontory, Wilbur never understood. Sheer determination alone must have carried him over that terrible scramble. His disabled leg caused no pain, rather he seemed to be dragging along a bulky and useless burden. Hardly had he drawn himself hand over hand around the sharp projecting crag and inspected the little cove on the other side, when expectant relief turned suddenly to hopelessness. So far as he could see, this new rampart offered no more chance of escape than the others he had passed by as unclimbable.

On one thing he was determined: he would not drown out there without making every possible effort to escape. Slowly he drew himself along the face of the cliff, grasping seaweed here and jutting rock there. In this manner he made surprisingly good headway. Suddenly, as he drew away from the little cove, he heard a splash behind him, followed by a shower of small stones. A boulder loosened from the crags above had plunged downward.

"Close shave!" the boy gasped, his throat tight with sudden fear.

Then, while gazing up at the fog-shrouded precipice, he noted a narrow cleft in the cliff into which the sea lapped intermittently. At first, the significance of the discovery failed to impress the boy; then, with a weak "Hur-ray!" he retraced his way with renewed hope, drawing himself up to the narrow cleft, his legs still dangling in the sea. With safety so near, he rested, grateful for the respite from constant exertion.

A few minutes later he tackled the cleft in the rock rampart, which sloped upward at about forty-five degrees. So narrow in places that Wilbur had difficulty worming his way upward, the cleft was obstructed here and there with boulders lodged in the giant crack. The rough surface of the cleft, combined with the occasional boulders, provided a fairly easy means for the almost exhausted boy to work his way upward. The cleft opened out on a gallery similar to the one from which Wilbur had plunged.

When he attempted to stand erect and walk, Wilbur discovered the seriousness of the injury to his knee. Unable to take a step, he was forced to crawl on hands and knee, his injured leg now causing him great distress. After a scramble that seemed endless, the boy reached the top of the cliff, from which point the lighthouse stood out boldly on the

island's commanding hill less than a half-mile away. At the base of the hill were the lighthouse-keepers' quarters. No imaginable refuge could have looked half so inviting as that weather-beaten cluster of buildings seemed to Wilbur at that moment.

Barely had he started his crawl toward the little settlement when the sharp eyes of one of the lighthouse crew noted the strange, white-clothed quadruped making awkward and uncertain progress toward the quarters. Quickly turning his glass on the strange object, he made out the tugboat captain's son.

A few moments later, Wilbur saw his father hurrying down the rough slope toward him. Then exhaustion, too long stayed off by sheer will, overcame the boy and he fainted dead away.

When he recovered consciousness in the warmth of the crew's quarters, Captain Conrad gradually wormed his adventure from him. At the close of his story, Wilbur could not help but marvel that the threat of death which the boulder crashing down the side of the cliff held out to him was the very means of his preservation. For had he not looked back when the boulder struck the water behind him, he would have certainly passed by the one chance of escape from the sea.



"WILBUR SAW HIS FATHER HURRYING DOWN THE SLOPE TOWARD HIM"





## WARNING TO ALL FAIRIES

(Sir Arthur Conan Doyle reports that he has photographs of fairies.—News item.)

By HAMILTON FISH ARMSTRONG

PUCK, go hide in some harebell;  
Mab, conceal your face,  
Lest an evil camera-man  
"Snap" your poise and grace.

Wary you have ever been  
As the spotted fawn,  
Sporting in the misty lights  
On the edge of dawn.

Dangers new beset you now;  
Men of science want  
Pictures of your airy crew  
In their forest haunt.

Leprechaun, beneath a leaf  
Creep without delay;  
Never let the camera-man  
Catch you out by day.



"MEN OF SCIENCE WANT PICTURES OF YOUR AIRY CREW"

Pixies and all Little Men,  
 Leave your tasks undone  
 If you run the slightest risk  
 Of going home by sun.

You who haunt the magic hills  
 Up by gray Glencoe,  
 Scan the patches in the gorse  
 Ere abroad you go.

They are armed with bulbs and plates,  
 Set by rule of thumb,  
 Waiting underneath the hedge  
 To catch you as you come.

Gather in the oaken groves  
 Beneath the mistletoe—  
 But, lest your faces get in print,  
 Go home by firefly glow!

Nereids and Oreads,  
 All you woody sprites,  
 Keep you to your wells and groves,  
 Save on inky nights.

Where the fairy rings arise  
 Through the summer grass,  
 There lie prying scientists,  
 Hoping you will pass.

## THE MYSTERY AT NUMBER SIX

By AUGUSTA HUIELL SEAMAN

*Author of "The Boarded-up House," "The Sapphire Signet," "The Dragon's Secret," etc.*

### CHAPTER I

#### WHO WAS SHE?

It would be difficult to say just why they had selected Number Six to explore on that particular afternoon. Mere chance had a large element in it. So had the fact that it was the only pool within many miles of their vicinity that they had not already become intimately acquainted with. Lastly, it was the farthest removed. They had had to travel twelve miles in the little motor-car to get to it.

Bernice lay contentedly at the edge of a sand embankment white as driven snow, her chin cupped in her hands, watching a half-dozen or more mullet drift and swing in the limpid water below. Sydney roamed along the sides of the pool, a hunting-rifle under his arm, also speculatively watching a brace of larger fish farther away.

There is nothing more utterly fascinating than an abandoned South Florida phosphate-mine pool, nor is there anything farther removed in appearance than the same mine in active operation. A phosphate mine in full swing is a busy, impressive, and unbeautiful thing. From the great shallow crater, many hundred feet in diameter, clouds of steam arise, making it not unlike a real volcano in effect. Freight-cars and locomotives grind back and forth on the sidings, carrying away the mined material; huge

hydraulic pipes are woven across the mine space; and at one side an immense washer, resembling nothing so much as the structure of a scenic railway in an amusement park, blots out the sky-line.

But the active usefulness of any one phosphate mine is only temporary. When its capacity for yielding the valuable material is reached (and phosphate is not generally found over fifty feet below the surface) the mine is promptly abandoned. All the paraphernalia of mining is moved to another region and the gaping hole is left, a horrid blot in the beautiful Florida landscape. But Nature seems to love that sunny land, and she soon provides a wonderful remedy for the desecration. In a few weeks the great cavity has become filled with crystal-clear water. Vegetation creeps rapidly over the ravaged environs, and, strangest of all, fish in shoals mysteriously find their way into the new pool, doubtless through subterranean channels, making it a paradise for the angler. And so the unlovely mine becomes a little gem of a lake—the longer it has been deserted, the more attractive and alive with fish.

"Sydney," called Bernice presently to her cousin, now standing some fifty feet away, "I never saw anything to equal the fish in this pool! They are bigger and there are more of them than in any of the other pools you've shown me."



"That 's because this is an old pool," the boy replied. "I think they say it 's the oldest mine-pool anywhere in this region. Has n't been worked for more than twelve years. Look at that bouncer over there! I 'm going to get him!" He pointed to a large pike lazily floating by, some fifteen feet out from where he stood.

"But, Syd, you did n't bring your rod," retorted the girl. "How do you expect to get him without a line?"

"I told you I was going to show you something new when we came out to-day. I am. Just you watch!" He waited till the pike was opposite where he stood on the bank. Then he raised his rifle to his shoulder, aimed at a point just underneath the fish, and fired. When the explosion and the resultant splash were over, the fish was seen floating on its back. It happened that the bank at this point shelved rather gradually out into the water. Sydney sprang in, waded almost to the top of his hip-boots, and caught the slippery body just as it had suddenly revived and was about to dive away. He bore it, still frantically flopping, to the shore and deposited it in his basket.

"Sydney!" gasped Bernice. "Where did you ever learn *that*?"

"A man who had hunted in Canada told me about it. It 's a great trick. You only stun the fish; but if you don't get him double-quick, he revives and gets away. Sometimes I bring a fishing-spear along and get them out that way. Hi! there 's another—right close by!"

He was off again in a twinkling, eager for another catch, and Bernice sat up to watch him with keen interest. But this time he was not so successful. He overshot his mark, and his prize, when the water settled, was nowhere to be seen. After that, he stood intent for a long time, waiting with sportsman's patience for another chance, and Bernice settled down again, watching him idly. Every little while she drew a long breath of content and snuggled down closer into the hot white sand. On the opposite side of the pool was an ancient orange-grove, and the scent of orange-blossoms was wafted to her with every puff of wind.

"Oh, I 'm glad I 've come to live in Florida!" she sighed aloud. Then she continued to meditate on the very opportune opening that had come to her father, who was not very well, to settle in Florida near his brother in the phosphate region and give his engineering knowledge to the mining interests. Her

cousin Sydney had lived in Florida for several years, but she had been having her first taste of it in the past glorious month. Every afternoon, she and her cousin had spent in the little motor-car, exploring the country far and wide.

While she watched now, Sydney raised his rifle for another shot and again missed. "Fired too low!" he called back in explanation and roamed on. Neither of them noticed a lithe little figure gliding behind them from bush to bush, keeping always in the shadow of some protecting shelter and watching them with alert and mystified interest. It would have caused them considerable astonishment to have known they were so closely observed. They did not suppose there was any one within miles of their vicinity.

Presently Bernice scrambled up and announced that she was going to explore the other side of the pool, where the orange-grove was, and sauntered off around the edge on her quest. The figure behind the bushes followed noiselessly, keeping always unseen among the scrub-palmetto growths. And Bernice, totally unconscious of being followed or spied upon, rambled happily along. In the grove she found two or three oranges hanging within reach, although the new blossoms were on the same trees (a combination that never failed to astonish her) and, resting under one of the trees, she ate a couple, saving the biggest for Sydney when he should arrive at that point. Then she roamed on again.

"Oh, Sydney!" she called back, suddenly and excitedly, "do you know—there 's an old farm-house here! I did n't suppose there was a house within miles of this place."

"I know, it 's an old deserted one," he called back. "Has n't been inhabited for years. I 've seen it once or twice when I 've been here before."

"But it 's inhabited *now*!" insisted Bernice. "There 's smoke coming out of the chimney and some plants growing in pails and boxes on the porch."

"That 's queer!" he replied. "The place has n't been lived in for ages. It 's all tumble-down. Wait till I get around there and see it with you." The quiet figure behind the palmetto scrub seemed more on the alert than ever and stood motionless, watching with half-anxious, half-wondering eyes.

But Sydney lingered several moments to obtain a shot at another tempting fish, and this time waded out, his prize in his grasp.

But as his foot touched the bank, Bernice heard him give an astonished shout, and looked up to see him struggling desperately with something that was slashing and beating itself about in a furious encounter with him. Without an instant's delay, she rushed around the edge of the pool to his assistance.

"Don't come near!" he called to her, thumping and laying about him with the

comes after me whenever I try. I've got to kill it!" He lunged at it again with the butt of his gun, then gave a groan of pain, dropping his rifle and seizing his hand, which the snake had evidently injured. In the same instant, the reptile itself, as if satisfied with the damage it had done, slid noiselessly away into the long grass by the pool's edge.

"Oh, Sydney!" cried Bernice, in an agony



"OH, I'M GLAD I'VE COME TO LIVE IN FLORIDA!" SHE SIGHED ALOUD"

butt end of his rifle. "It's a horrible snake—" He stopped talking, for lack of wind and because every energy was needed to ward off his assailant. It was, indeed, a snake, as Bernice could plainly see for herself—neither a rattler nor a moccasin, but a hideous creature that seemed to be growing steadily bigger and longer and more venomous and terrible in appearance as she watched. It was like nothing she had ever dreamed of or heard of before—an awful nightmare—to see the reptile grow visibly, before her very eyes.

"Oh, run, Sydney, run!" she implored. "Don't try to fight it. Just get out of its reach!"

"I can't!" he panted. "The horrid thing

of apprehension. "What *shall* we do? The creature has bitten you. We're miles from home or a doctor! Is it as poisonous as a rattler or a moccasin, do you think?"

"I don't know," muttered the boy, staring down almost stupidly at his wounded wrist. In reality, he was a little stunned and stupefied by the suddenness of the attack and the wound he had received. "It hurts a good deal and it's growing numb. We'd better get right home. I don't believe I can drive the car. Can you manage it?"

"I'll do the best I can," she said. "You know I've only driven a little since you began to teach me. Come! let's get to where we left the car—quick!" She seized his unwounded arm and began to hurry him



toward the car, standing far around on the other side of the pool. But the attack by the snake was too much for Sydney. He turned suddenly dizzy and sat down on a sand hummock, sinking his head onto his knees. And Bernice, sure now that he was fatally hurt, sank down beside him in despair and began to sob softly.

"Please!—if you will let me, I think I can help!"

Bernice looked up in astonishment—she had no idea there was any one around, and she gasped in further wonder at the figure she saw standing before her.

It was a girl, presumably about her own age—fifteen. She was small in frame, lithe and dark, barefooted and rather unkempt in dress, wearing a ragged blue skirt and soiled white middy blouse. The tangled mat of hair was very dark, almost black, and unconfined in any way. Her complexion was tanned to a golden-brown hue, evidently through long exposure to the sun. But her features were very pleasing and regular, and her eyes were wonderful—large and iris-blue, surrounded by lashes long and dark and curling. It was the eyes chiefly that arrested Bernice.

"Who—who are *you*?" she could only stammer.

"I live in the house—over there." The girl indicated the old farm-house in the orange-grove. "I—I saw what happened. I think I know what to do—if you will let me?"

"Oh—thank you! Do anything—*anything*! We'll be so grateful!" cried the distracted Bernice.

Without another word, the girl bent down and raised the boy's wounded wrist that he had left hanging limply down. She turned back the cuff of his shirt which, originally rolled to the elbow, had now fallen over the wrist, scanned the wound critically, and then turned to Bernice.

"Has he got a handkerchief?" Bernice extracted one from his pocket, Sydney all the while inert in the half-stupor that seemed to possess him. The girl quickly tore it into strips and with them bound his arm tightly just above the elbow. To make the bandage tighter, she inserted a small stick and twisted it till Bernice fairly winced, so white and bloodless did the lower arm suddenly become. Next she laid her lips to the wound and drew out whatever poisonous matter might be there, while Bernice looked on, wide-eyed and apprehensive. Sydney, meanwhile, revived enough to realize what was going on.

"I got awfully dizzy!" he said apologetically; and then for the first time realizing that there was a stranger on the scene and that this same stranger had been rendering him efficient medical service, he braced up with an astonished, "Oh, thanks, awfully! You're very good to have done so much. I got bitten by something, I guess. Hope it was n't a rattler!"

"It was n't a rattler! You would be in bad shape by now, if it was," replied the girl. "It was n't even a moccasin. A hog-nosed snake—that is what it was. They are not often seen. They're not poisonous, but they have a terrible way!"

"I should say they do!" cried the boy. "The little wretch was only about a foot and a half long when I first saw it lying there. I made a strike at it, and it suddenly began to swell up and get longer and longer and its eyes were like red sparks and it fought like a demon! I've never come across its like since I've been in Florida. But thank *you*—so much for what you've done! I think you've saved me from having a bad arm, at least."

"It was n't anything!" the girl said; and suddenly overcome by an unconquerable shyness, now that the crisis was over, she turned on her heel and walked rapidly away, increasing her pace to an actual run when she had put a short distance between them.

"Wait, wait!" cried both the young people. "We want—"

But she was out of sight in another moment, and later, as they stared after her, they caught a brief glimpse as she flashed into the old farm-house and disappeared from view.

"That's mighty queer!" commented Bernice. "She might have waited a little longer till we could thank her properly and find out who she was! But come along now. You must get straight home and have a doctor tend to your arm. She has probably saved you from any immediate bad effects, but you ought to have it cauterized or—something. I'll drive and you can help me out if I get in trouble."

Late that afternoon, when Sydney returned from a visit to the doctor who had put the finishing touches to his arm, he had a curious bit of news to retail to Bernice.

"I got talking down at Caswell's store about that Number Six pool and who's living in the old deserted farm-house now. I was real curious to know who that strange kid could be. Most of them did n't even

know it was inhabited; but old Ike Massey said he 'd heard that that famous half-breed Indian guide, old Jerry Sawgrass, has come up lately from the Everglades where he used to live and has married a Florida 'cracker' woman from way in the backwoods somewhere, and they 've hired that old farmhouse and are going to live there. But here 's the queer thing about it—no one knows who the girl is. She 's not from around here anywhere. She does n't belong to the cracker woman, and they think she is n't a daughter of Jerry's. Yet they say he brought her up from the Everglades with him. Ike thinks she is n't an Indian or a half-breed, and yet only the Seminole Indians live in the Everglades. Jerry declares she 's his niece, and he won't say another word about her. What do you think of *that* for a poser?"

Bernice opened wide her big gray eyes and stared fixedly at her cousin.

"Don't tell me there 's some *mystery* about her!" she gasped. "It 's too good to be true! Oh, if there 's anything I *adore*, it 's a mystery!"

## CHAPTER II

### JERRY SAWGRASS ENTERTAINS

BERNICE spent the next two days in excited speculation, while Sydney was recovering the use of his arm. Decided zest was added to her wonderful new life in Florida by the introduction of so piquant a matter as they had accidentally stumbled across. When her cousin was at length able to run the car again without difficulty, she straightway proposed that they visit Number Six at once and try to see the curious new inhabitants of the old farm-house.

"Yes, and I want to thank her, too, for what she did," agreed Sydney. "What do you think would be nice for us to take her—something she would n't be likely to have? How would a book do, or some candy?"

"Don't take a book!" laughed Bernice. "She probably can't even read if she 's come from such an uncivilized place as the Everglades. Let 's get a big box of the nicest bonbons we can find. I warrant that will be something she 's never had before!"

So, armed with a five-pound box of chocolates, they drove to Number Six in the car the next afternoon, intent on the payment of their debt of gratitude. As the road around to the grove was very rough and cut by old railroad-tracks, they decided to leave the car where it had stood on their first visit

and proceed on foot. Much to their surprise, sounds of shouting and laughter and splashing came to them as they drew near the pool; and curious to learn the cause of it, they crept noiselessly to the edge. The sight that met their gaze took their breath away.

Seated on the edge of a high bank above the pool was the girl, attired in a tattered bathing-suit. With a long pole she was prodding at something down below—something that floundered and splashed and lashed about protestingly in the shallow water. Bernice uttered a frightened little cry and clung to Sydney's arm in a panic. "Do you see what she 's *doing*?" she choked. "Look at that awful—ugh! But, good gracious—let 's *run*! This is frightfully dangerous!"

Sydney laughed. "It is n't a bit dangerous. But I confess I never saw a girl with quite nerve enough for *that*!"

"But, Sydney—an *alligator*—a *huge* alligator—and in a pool like this!"

"Why, these pools are full of 'em—in the season," Sydney reassured her. "They begin to come out of the mud at the bottom, about now, for the summer season. They 're harmless and they 're scared to death of humans and are always trying to get away from them. People bathe and swim in these pools with half a dozen of 'em peacefully occupying the other side."

Bernice, however, continued to shudder.

Just then the girl on the opposite bank stood up, took a flying leap, and dove straight into the pool, not twenty feet from where the old 'gator was trying clumsily to burrow into the mud and sand at the water's edge. With a great shouting and splashing, she drove him back on shore again, and then clambered out herself to scramble up the steep bank and continue her teasing and prodding from above. But when she reached the top, she caught sight of the two visitors on the opposite bank and hesitated for a visible moment; and in this moment the old 'gator clumsily waddled down to the water and was lost to sight in an unbelievably short space of time. But the girl, after another glance across the pool, turned and fled hastily through the grove and into the farm-house and was lost to view.

"Let 's go back home, Sydney!" shuddered Bernice. "I 'm scared to death to stay around here with that awful creature so near. It can't be safe!"

"Nonsense! It 's as safe as a church!



This is just your first experience. You 'll get so used to seeing 'em you won't even give 'em a second glance after a while. We 'll walk around to the house slowly, giving her time to dress and then make our 'party-call'! I 'm crazy to see old Jerry. He 's been a famous guide in his day. Knows the Everglades like a book, they tell me."

Protesting still, Bernice allowed herself to be reluctantly led along, and presently they stood before the tumble-down veranda on which were now blooming ferns of wonderful luxuriance in old soap-boxes and leaky pails. Sydney advanced boldly up the rickety steps and knocked at the half-open door. A fat, unkempt, and more than middle-aged woman answered his knock. Her hair had obviously not been combed that day, she held in one hand a corn-cob pipe, and there were unmistakable signs that she was addicted to snuff. To Sydney's polite "Good afternoon!" she responded "Heigh!" which appeared to be the typical "cracker" greeting of that neighborhood.

"Is—is the young girl who lives here at home to-day?" he stammered, scarcely knowing what to inquire.

She stared at him in stolid wonder, but her only reply was to hold the door wider and say, "Come in an' set, wun't yer?"

They both entered somewhat timidly, to behold a man seated by the empty old chimney-place, rocking silently in a decrepit rocker, smoking as silently a blackened pipe which he removed only long enough to nod to both and resumed without uttering a word. If this was the famous Jerry Sawgrass, thought Sydney, his appearance was a decided disappointment. His faded cotton shirt, dirty khaki trousers, and heavy boots suggested nothing of his romantic calling; his heavy, bearded face with the long mustache falling down to mingle with the unkempt beard was more like the ancient bucanears, to Sydney's mind, than in keeping with a half-breed Indian guide. However, here he was, but there was still no sign of the youngest member of the trio.

In utter silence the four sat for several awful moments, and then Sydney plucked up courage to ask again for the unseen girl and tell briefly the reason for their visit.

The only response to the tale was that the woman lifted up her voice and called loudly, "Dell! Dell! Come out! I reckon you 're wanted!"

After another long interval, the door to an inner room opened and the girl stepped out,

clothed as she had been at their first encounter, a half-frightened, half-inquiring expression in her big eyes. Sydney rose courteously, explained again their visit, and presented the box of candy, laying it in her reluctant hands. An embarrassed pause ensued, while she stood there, staring down at it, plainly at an utter loss how to proceed. It was Bernice who came to her rescue.

"May I open it for you?" she asked, and took the package from the girl's unresisting hands. Having removed the wrapper, she had a sudden inspiration, took off the cover, popped one of the candies into the girl's half-open mouth, placed one in her own, and passed the box around the room to all the others. It was decidedly not conventional, but it worked. Miraculously the ice was broken. A delighted smile overspread the face of the girl and the woman. Even old Jerry relaxed into what passed for a grin.

"My! ain't them things good!" commented the woman, and Bernice promptly passed her another. In a moment they were all munching, and the woman was telling how "she had n't had no candy sence she left her home town two months ago." Sydney then thought he 'd try his hand at drawing out Jerry and began on a series of animated questions about the Everglades. But Jerry was either not gifted in conversation or he did not feel communicative that day, for not a word could the boy draw from him—nods and grunts, affirmative or negative, but not another expression issued from behind his solemn beard. At last the boy gave it up in despair, and the two visitors rose and took their departure. No one asked them to come again, except the woman, who was plainly uneasy at the deficiency in affability of her lord and master.

"He 's got the misery in his back to-day," she explained. "He 's often took that way. That 's why he can't live in them swamps no more."

The girl seemed to have faded imperceptibly into the background and was nowhere to be seen when they left. But down by the edge of the pool and well out of sight of the house, they were suddenly arrested by her figure, rising up unexpectedly from a big scrub-palmetto clump.

"Wait!" she said. "Don't talk too loud, please." And she glanced back over her shoulder at the cottage. "I—I want to—to thank you again for—the candy!"

"Oh, the thanks are all on my side!" exclaimed Syd, gallantly. "If it had n't been

for you, I might have been in pretty bad shape. The doctor said you made a splendid job of it—left very little for him to do.”

“I ’m glad,” she said simply, then hurried on. “But I want to say something else. I don’t want *them* to know—they might n’t like it, but—I—I wish you would come often,—both of you. I—I ’m *lonesome!*” She stopped abruptly as if frightened at having said so much.

“Why, of course we ’ll come!” declared Bernice, impulsively. “We ’ll come every time we can manage it, and we ’ll take you out in the car for rides sometimes, if you care to go—”

“Oh, no, *no!*” the girl protested in quite inexplicable panic. “I can’t do that. They—they would n’t like it.”

“But why not?” demanded Bernice, indignantly. “It ’s perfectly safe. Sydney is a splendid driver.”

“It—is n’t that. They—they don’t want me to see many people.”

Bernice stared at her in amazed incredulity. “But—pardon me!—may I ask why? What possible harm can there be in it?”

The girl became very much embarrassed. “It is—is hard to explain—I know. I—I just can’t explain it, I ’m afraid. But if—if they think I am seeing any—any one, they will move away again—to some place that is farther off from—people.”

“I can’t understand it!” cried Bernice.

But Sydney interposed. “Well, never mind if you can’t. That ’s not our affair. But we ’ll come whenever we can, anyway. How shall we manage it, though, if we ’re not to let er—Mr. Sawgrass and his wife know of our visits?” He turned questioningly to the girl.

“If you leave the car a good ways off—in the brush—and never come over this side of the pool, it will be all right. Don’t try to call me or signal to me—in any way. I will be over there a part of every day. I ’ll always see you.”

“But won’t they—the—er—I mean your father and his wife—ever come over on that side?” questioned Sydney.

An indignant flush spread under the girl’s dark skin.

“He—he *is n’t*—that is—I call him Uncle Jerry,” she retorted. “No, they will not go over that side. He has some kind of sickness, I don’t know what it is. Anyhow, he can’t live in the Everglades any more and he can’t get around much. And *she*—” an expression of faint contempt appeared in her face for an instant,—“she ’s lazy. She never goes out of the house or beyond the yard and garden if she can help it.”

She walked along with them to the other side of the pool and they came to where the car stood. Bernice’s mind was fairly sizzling with a host of questions that she longed to ask, yet which something in this strange girl’s restraint prevented her from uttering.

“You ’ve been very—very good to me,” the girl said wistfully as they clambered in, “to bring me all that candy. I never had anything like it before.”

“Tell me,” asked Bernice, for this she felt would be a quite legitimate question, “have you lived in the Everglades all your life—before this?”

“Yes—in them or right on the edge. This is the first time I ’ve ever been so far from them.”

As they started the car and prepared to drive away, Bernice suddenly leaned out. “We ’ll come again—very soon. But—I ’most forgot!—we have n’t even told you our names. I ’m Bernice Conant and this is my cousin, Sydney Conant. We ’re living over at Jasper, the phosphate town about twelve miles from here. And shall we call you—‘Dell’?”

Again the annoyed flush crept up under the girl’s dark skin. “*They* call me that—but my real name is—Delight!” And she turned and disappeared into the underbrush.

(To be continued)



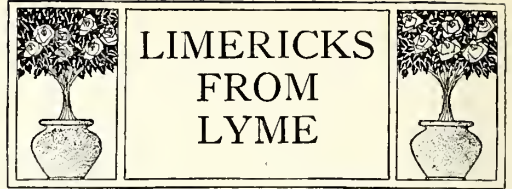
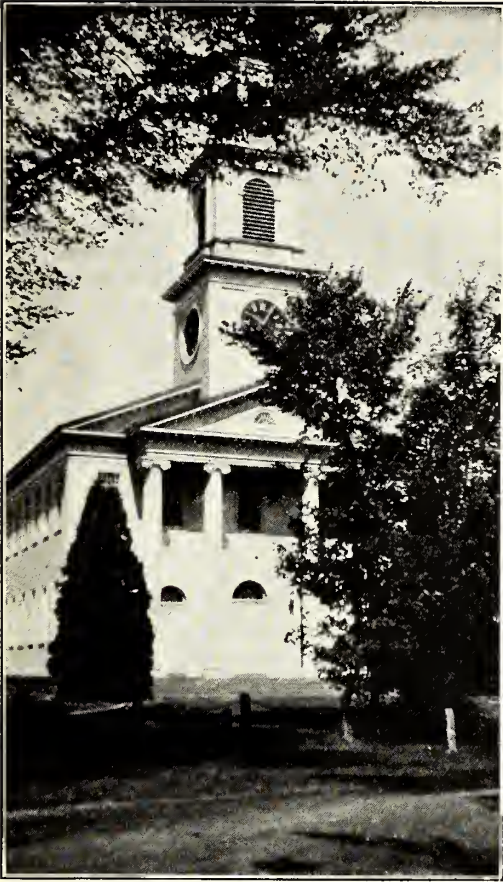

LIMERICKS  
FROM  
LYME

By LUCY A. K. ADEE



THE  
STEEPLE  
CLOCK



THERE was an old clock in a steeple,  
Which hourly called to the people.  
It rang loud and clear  
Through the whole livelong year,  
This steady old clock in the steeple.

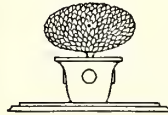

THE  
GARDEN



THERE is an old garden at Lyme,  
Where grow hollyhocks, asters, and thyme.  
They stand in a row,  
Some high and some low,  
In this lovely old garden at Lyme.



# THE GREAT BALLOON FLIGHT

By RALPH UPSON

I DON'T know how it all happened in the first place, but the important thing is that Clifford and Louise Blake actually *did* make a balloon flight with their Uncle George, who, according to all accounts, is quite a famous pilot. It was the last flight he made before winning the American National Race. As to how far the experience helped him to win, you must judge for yourself; but at least it seems clear, from the accounts of two members of the party, that it was the greatest flight ever made. You should really hear them tell about it themselves; but the next best thing is for me to combine the three accounts as well as I can into one story.

At first, it seems, there was some question as to whether the balloon would carry all three, because it was a small one, built only for two persons. But the two younger members of the crew promptly settled that argument by getting on the scales together and showing that their combined weight was only about the same as that of Uncle George alone. In spite of it being the end of May, there was also some doubt about the weather, but this turned out fine—at least to start with.

It was easy enough to figure how long the inflation would take, as the balloon held 30,000 cubic feet of gas and the big gas-pipe at the field could deliver 15,000 cubic feet an hour. They also allowed another hour for spreading the balloon out and getting the valve in place, and an additional half-hour for final arrangements before the start. So the party began at half past eight in the morning, with the idea of leaving the ground about noon.

Fifty ballast-bags had already been filled with sand to about thirty pounds each, and as soon as the balloon was spread out with the net on, these bags were set around the outside and hooked into the net. The gas was then turned on, and the balloon soon looked like a huge mushroom without its stem. The gas went in so fast that, in spite of the many willing helpers, it was all they could do sometimes to shift the sand-bags down fast enough. In about two hours they were down at the bottom of the net, and the balloon looked like a great silver ball, shining in the sun.

The gas-pipe was disconnected and the

basket moved underneath the balloon. All the sand-bags were then shifted to the "foot-ropes" on the bottom of the net, from where they could be slid down to the basket as the balloon was let up above it.

Clifford, being in first-year high school, was given the job of figuring out how much ballast to put in the basket. He knew that the gas would lift forty pounds per thousand cubic feet; also that the balloon itself, complete, weighed 470 pounds, food and other things about thirty pounds, and the three members of the crew 340 pounds. He soon announced that it would take twelve bags of ballast to make everything balance. In the meantime, Louise was packing some lunch and Uncle George was giving everything a "last over."

A factory whistle sounded in the distance. The pilot looked at his watch—just twelve o'clock. "All crew get aboard," he ordered. This done, the helpers held fast, while all the sand-bags were taken off except twelve, which were put in the bottom of the basket.

"Hands off!" came the sharp command, which was promptly obeyed by those holding the basket. Instantly the balloon started to rise, at the same time pulling off in the direction of the wind. "Hold on again!" and the ground crew had just time to grasp the basket before it was out of reach. "Too much lift—probably the bright sunlight. On with another bag!"

"Now, once again.—Hands off!" This time the balloon seemed to hang suspended and only drifted horizontally with the wind. "Hold on again! Clifford, empty half of that bag you have!" The pilot then pulled a cord which opened wide the "appendix," or lower neck of the balloon.

"Hands off!" They were slowly rising. "Stand clear, every one! We're off. Good-by and many thanks for your help."

"Telephone as soon as you land!" came a voice from below.

"We will!" Louise fairly shouted, for, with every second, they were a good five yards farther away.

It looked to Clifford as if they were headed straight for the tall trees at the side of the field. "Sha'n't I throw out the rest of this bag?" he asked.

"No," said the pilot, "but stand ready if I



tell you to." He stood watching alternately the instruments and the trees. "We'll clear by a safe margin," he soon announced. And so it proved—the balloon was ascending faster all the time and passed fully twenty feet above the tree-tops.

But there was no motion to be felt. As



"THE BALLOON SOON LOOKED LIKE A HUGE MUSHROOM"

Louise said afterward, she expected to have a sinking feeling, as on a rising elevator; but actually, without watching the ground or the instruments, there was no way to tell they were moving. The slight swaying that had occurred on the ground was now stopped. Even the breeze was no more, and a great calm seemed to surround them; for now they were traveling *with* the wind, a very part of the air in which they floated. Louise did admit that she had a "funny feeling" in her ears, but that it stopped as soon as she swallowed. I happen to know that that was because of the air-pressure getting less as they went up. It is the same thing that makes one of the instruments, the "altimeter," tell how high up you are.

According to the altimeter, they were now one thousand feet up and almost in equilibrium. Clifford, who had brought his camera along, suddenly remembered that he

wanted to take a picture of the starting-field from the air. It was now so far back that they could hardly make out the field at all, but finally recognized a little white spot as the big "ground-cloth" on which the balloon had been spread.

They were traveling away from the town, which now lay off to the south, overhung by a light curtain of smoky mist. Ahead lay the broad open country, with its checkerwork of farms, interspersed with the dark green of the woodland. A small river, like a silver thread, followed a winding, crooked path, to be lost to sight in the distance. In another direction, an occasional gleam of light showed where the sun was shining on a small lake.

Besides the shadings of color that marked the different fields, there were several very large dark spots of irregular shape that seemed to be moving over the ground.

"What can they be?" asked Louise.

"Shadows," said Uncle George; "look above you."

And there was the answer. The sky had been clear all the morning, but now it was scattered with fluffy white cumulus clouds, caused by the rising and cooling of moist, heated air. Soon the balloon itself passed

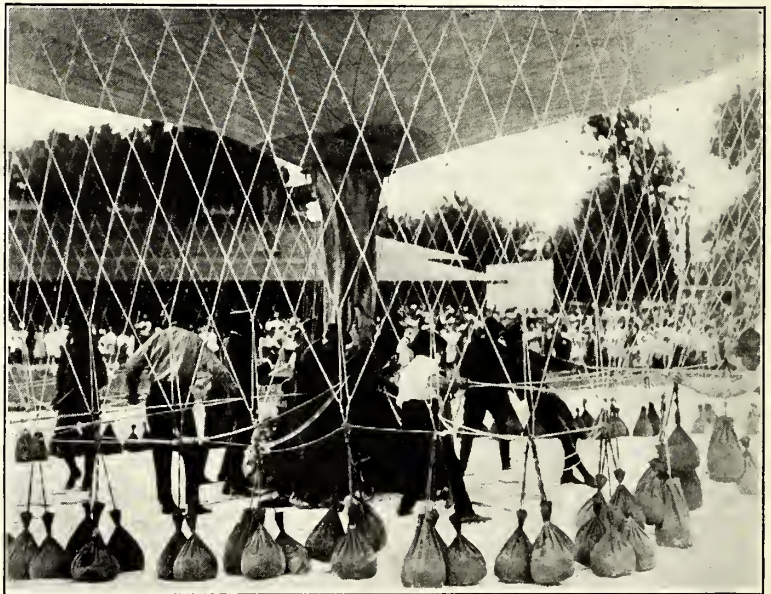

"THE GAS-PIPE WAS DISCONNECTED AND THE BASKET MOVED UNDERNEATH"

into the shadow of one of the smallest of these little clouds.

"I don't like that," said the pilot; "our gas will cool off now and cost us some bal-

last." But he waited to see what would happen, and watched the "statoscope." This is an instrument with a little glass tube, which is very sensitive to changes in altitude; air-bubbles go through it in one direction for "up" and in the other direction for "down." Sure enough, soon the statoscope showed "down." Over went a handful of sand, then another, and in spite of the sun coming out again, it took nearly two bags of the precious sand to stop the balloon from coming right down to the ground.

"Now we've got her going up again," said the pilot. "We could stop it, if we wanted to, by valving out gas, but it won't hurt to go on up and see what the wind is doing up there."

They had noticed while down near the ground that they were traveling almost due north. This could be told without looking at the compass, because most of the farm lines and roads in that part of the country were laid out exactly north and south, and east and west. But as they got higher and higher they cut across the farm lines more and more toward the east.

Louise had been looking up. "Why, I believe we are going to bump right into that big cloud," she said.

"Let her bump," said Uncle George.

But this is what actually happened: first a fine white mist came rushing down around the balloon; then it got so thick that they could n't see the ground. Now there was nothing to be seen in any direction except the thick mist. Imagine, if you can, how the world would look to a little bug in the exact center of a bottle of milk standing in the sun. That is just about the way it looked to our balloon crew at that particular moment—no earth, no sky, nothing but dull white in all directions. Gradually it grew brighter. Finally, they could see little streaks of blue sky above. Then suddenly—it was just as sudden as if some one had switched on an electric light—they were through the top of the cloud, as through a curtain, and found themselves in the dazzling bright sunshine. The sky above was a deep clear blue, and the cloud surface below an intense white.

"I can hardly look at it," said Louise, "it hurts my eyes so." "It's lucky I brought these along," said Uncle George, as he pulled from his pocket three pairs of smoked glasses. With these on, the clouds appeared even more beautiful, for every little curve and hollow could now be plainly seen. Still they kept on rising, until they could scarcely see

the cloud they had passed through, among the almost countless white forms beneath them. It seemed to be a whole world of sky and sun and beautiful fantastic shapes.

After losing still more ballast, they finally



"THE BALLOON WAS ASCENDING FASTER ALL THE TIME"

rose to 10,000 feet altitude,—almost two miles, high,—where for nearly an hour they found fairly good equilibrium.

"How are you feeling?" asked Uncle George, as soon as there was a chance to consider one's feelings.

"My feet are cold," answered Louise, "and yet the sun seems so very hot."

"The sun *is* hot," said Uncle George; "but it shines right through this clear air without heating it much, so the air is really quite cold. I don't wonder your feet are cold, being in the basket out of the sun."

The principal thing that Clifford felt was being a little out of breath, as if he had been running a race, and, at the same time, drowsy.

"You may not know it," said Uncle George, "but the chief thing all of us need is food."

"You said something!" was the only re-



mark from Clifford, who was already digging in the pockets of the basket for the lunch.

The clouds kept getting thicker underneath, but occasionally patches of ground could be seen between them. This gave the pilot a chance to figure the speed and direction of the balloon. To do this, he picked out a spot on the ground (in this case a road-

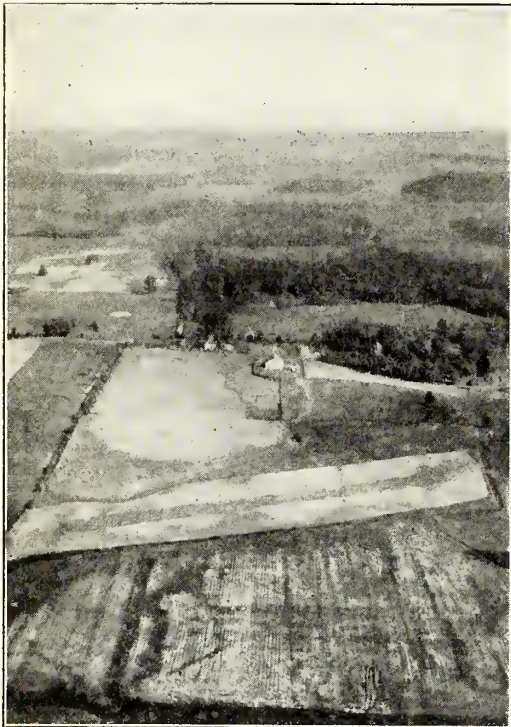

LOOKING FOR A LANDING FIELD. THE ONE IN THE FOREGROUND WOULD DO, BUT FOR DAMAGE TO CROPS. THE OPEN SPACE BEYOND THE WOODS WAS SELECTED BECAUSE IT WAS SHELTERED FROM THE WIND

crossing) which happened to be directly beneath. Then he counted the seconds on his watch till the road crossing got back in line with a pair of little "gun-sights" on a slanting stick which he carried. Then he found the height from the "altimeter"—and that is all he needed to figure out the speed. You can do it, too, after you have studied trigonometry. To get the direction was easy, for all he had to do was "sight" back over the compass toward the same spot on the ground, which was, of course, just opposite to the direction in which the balloon was going. And this is what he found—that they were going a little *south* of east at a speed of *fifty-two miles an hour!* And the Atlantic Ocean was less than a hundred miles away!

"That means that we shall have to come down soon," said Clifford.

"A wise remark," said Uncle George. "As a matter of fact, I think we are coming down *very* soon. Look around you and tell me what you see. It 's the last chance."

Clifford was the first to see it (surely it had not been there half an hour before) a huge mountain of cloud off to the southwest. Evidently it was still a good ways off, but it seemed to tower to the sky, with roll on roll of massive cloud in every conceivable shape. The hollows looked dark and cold; but wherever the sun touched, it was more brilliant than the whitest snow. Above and in front of this cloud mass were streaks of beautifully light, feathery-looking cloud,—the cirrus,—advance messenger of wind and storm, traveling at a height of over four miles.

Ever larger and nearer grew the big cloud, or what seemed more like ten thousand clouds rolled into one. Now in its dark spots they could see sudden flashes of light. In another minute came a faint crackling, followed by a dull, rumbling roar. The passengers knew that this biggest of all clouds was the cumulus-nimbus, the home of a thunder-storm.

"It 's still twenty miles away," said the pilot, "but we have none too much time." He hauled down strongly on the valve-cord and held it while he counted ten. Then the statoscope began to show a slow descent. "Drop the drag-rope," came the order to Clifford. This was a thick rope about two hundred feet long, which up to this time had been hung in the form of a big ball on the outside of the basket, with its upper end fastened to the "load-ring" above the basket.

Clifford, with his knife, cut the cords that held the ball of rope. Then it dropped free, unwinding as it fell, until it hung full length from the balloon. (Don't ask just yet what this rope was for.)

By this time they were coming down much faster, and the balloon, which before had been full and round, now had great folds across the bottom, making it look generally sick and undernourished.

Down they came faster still. "How much ballast have we left?" asked the pilot, in a quiet voice.

"Three and a half bags."

"Well, empty the half bag and stand by with the rest."

They were going down so fast that when Clifford poured the half bag over the side of the basket, the sand went streaming up instead of down.

"Are n't we going to land pretty hard?" asked Louise.

"No," said Uncle George, "but you must do exactly as I tell you. Now listen carefully. Louise, you are to throw out the packing-cloths in case I tell you to. Clifford, you are to pull the rip-cord—this red one—when I give you the word. In the meantime, each of you be ready with a bag of sand. When we hit, just bend your knees a little, the same as if you were jumping off a table;

"We have come down into the calm area just ahead of the storm," said the pilot; "and to avoid the wind, we must land within a few minutes, even if we have to hang up in a tree."

Just then, Louise picked out a small clearing some distance ahead. They were coming down very slowly now, and the pilot let the balloon settle until it reached a current that was heading almost directly toward the clearing. A few hundred yards farther on, a



"BELOW THEM LAY THE BEAUTIFULLY WOODED HILLS"

hold on to the drag-rope side of the basket, and *don't get out till I tell you to!*"

They were now approaching the lower clouds, still out of sight of the earth. Just as they plunged into the clouds, over went the contents of two bags, at the pilot's orders, while he kept the remaining bag himself. The mist closed in around them—then just as suddenly they were out of it again. Like *Alice* after jumping down the rabbit-hole, they seemed to be in a different world. Gone was the sun, the blue sky, the feathery cirrus, and the towering cloud-mountain. Below them lay beautifully wooded hills with their fresh green foliage. Off to one side was a deep valley with a stream at the bottom. In another direction was a clearing where they could see a small house with a thin stream of smoke curling out of the chimney. A light gray sky of hurrying clouds lay above, while to the west and southwest, coming steadily nearer, was the great black thunder-cloud, pulling behind it its curtain of rain.

sharp pull on the valve brought the end of the drag-rope down in the tree-tops just ahead of the open space. The wind had increased a good deal by this time, and the basket jerked and swayed as the big rope crashed through the trees. Another good pull on the valve, and the balloon headed directly into the clearing.

"Over with the packing-cloths! Ready with the rip-cord! Now, pull it out as fast as you can!"

In another minute they had hit the ground. The balloon, now half empty, bellied in the wind like a great sail, and pulled ahead as the basket went sliding and bumping over the ground. As they came to a stop, the basket went over on its side, tumbling the crew into a heap.

"It 's as good as a foot-ball game," remarked Clifford, as he disentangled himself and gave a hand to Louise. "Why, look at the balloon!" By this time the gas was entirely out of it and it lay perfectly flat on



the ground. In its upper side was a huge rent where Clifford had pulled out the rip-panel.

"Well, the balloon trip is over," said the pilot, after they had clambered out of the



A WORLD OF FANTASTIC CLOUDS

basket; "but I think there is still some fun ahead. Look what 's coming."

The others turned, and for a few seconds they all stood looking back as if spellbound at the approaching storm. But their day-dream was soon broken by a bright flash, followed by the heavy rumble of not so distant thunder.

"We can never make it," said Uncle George. "That house we saw must be five miles off. We 'll stay right here. Come on, let 's disconnect the basket!"

This done, they moved it around to the other side of the balloon, where the ground was considerably higher. Then they rolled back the fabric of the balloon a few feet, set the basket on its side there, and pulled the fabric over again, so that it completely covered the basket like a tent.

By this time, big drops were falling and a regular gale was lashing the trees. "Here, some one help me!" called Louise, who had almost disappeared in the darkness toward the edge of the field. The other two ran over and found her struggling with a load of sweaters, packing-cloths, and odd material that she had thrown out of the basket as they came down. "I came back for my sweater," she said, "but thought I might as well rescue the whole lot." The others laughed, but helped carry the things to the basket.

There was no time now for anything but to crawl into their manufactured cave and sit there. Soon the rain was beating down on the fabric roof. Inside, there was a momentary flood of light, followed almost

instantly by a deafening crash of thunder. The rain poured down afresh and then took on a new sound, a kind of rattle.

"Listen—hail!" said Uncle George, almost shouting to make himself hear. "Look at it bouncing around on the ground! It looks as big as marbles. You can be mighty glad we are not up in that," he continued. "You 'll see what I mean when I tell you how hail is formed. You know, in a thunder-storm, there are very strong vertical winds as well as horizontal. Sometimes some of the rain-drops, before they reach the ground, get caught in a strong wind blowing upward. It carries them right up with it, so high that they freeze into little balls of ice. Then they fall or are swept downward again through a wet cloud, which puts another layer of moisture on them. But still the little ice balls can't reach the ground, but are caught up again in the great uprush of whirling air. The new layer of moisture is now frozen in its turn, and makes the ball a little bigger. Hailstones like those you see probably have made a dozen or more round trips to an altitude of several miles before they fall through to the ground by their own weight. Now you can see what would happen to a balloon in such a mix-up. It would be all out

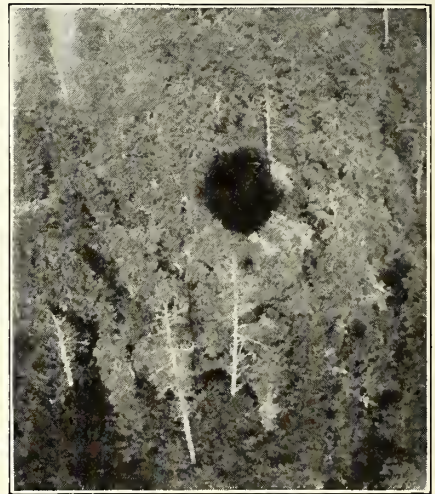

SHADOW OF THE BALLOON ON A BIT OF WOODLAND

of control, and you would have to ride round and round with the hailstones till the wind got tired playing with you."

The rest of the story is a long one, but I need not take long in telling it. By the time the storm was over, it was getting so late that there was small chance of being able to

get out of the woods before dark, so they decided to spend the night in their cave. Then the others were very glad that Louise had thought to get the sweaters and things, for, without them, they would have been half frozen. As it was, in the morning every one claimed to have had a fairly good sleep, although Louise was the only one who could stretch out full length in the basket. But hungry? They could have eaten several bears apiece! So they were up with the first daylight, tramping through the wet woods in the direction in which they had seen the house. Uncle George went by his compass, and soon they struck a wood-road leading in the right direction.

At the end of about two hours, they came to a big clearing where there was a house and barn. The farmer and his wife took them in most hospitably, and soon they were sitting down to oatmeal, ham and eggs, and everything else. Other people lived near by, so, later in the day, Uncle George, with Clifford and some other men, took a team and drove back to get the balloon. Louise found a house with a telephone where she called up her mother on the long distance.

They had to sleep at the farm-house that night, but next morning the whole party drove to the nearest station, which was about

twenty miles away. The farmer and Clifford rode in the front seat, while Uncle George and Louise sat perched on the rolled-up balloon in the back of the wagon.

There was n't a train until noon-time, and they did n't get home until the following morning. That made nearly three days to get back over a distance that they had cov-

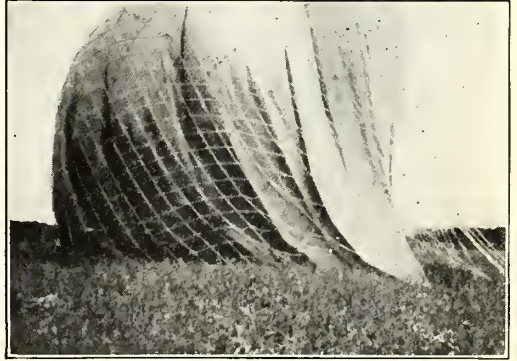

THE END OF THE BALLOON FLIGHT

ered in the balloon in little more than four hours.

"Well, how did you like it?" asked Uncle George.

"Not so *bad*," said Clifford.

"Let 's go again sometime!" said Louise.

## THE WHITE-THROATED SPARROW

By ELEANORE MYERS JEWETT

WHEN willow wands are yellowing  
 Beneath an April sky,  
 When sodden fields are mellowing  
 And violets are nigh,  
 Wood violets are nigh,  
 The mating birds on every side  
 Fling out their carols glad and wide,  
 And there 's a sweeter, clearer note  
 That bubbles from a feathered throat,  
 A dreamy, questing lay—  
 "Sweet-Sweet-and-far-away!  
 Sweet-Sweet-and-far-a-way."

A troubadouring sparrow, he,  
 Unlike the common herd  
 Who seek their lovers noisily  
 With flashing wing and word,  
 With flaunting wing and word,  
 He sits upon a twig apart

And sings a vision in his heart,  
 A lady-love unseen and far  
 And not as other sparrows are—  
 ('T is thus he seems to say):  
 "Sweet-Sweet-and-far-away!  
 Sweet-Sweet-and-far-a-way."

When all the other mating birds  
 Are intimate and shrill,  
 The white-throat sparrow's dreamy words  
 Sound sweeter, farther still,  
 More vision-haunted still;  
 "Sweet-Sweet-and-far-away,"  
 From dawn till closing day,  
 The little feathered troubadour  
 Is calling, calling evermore  
 His princess-far-away—  
 "Sweet-Sweet-and-far-away,  
 Sweet-Sweet-and-far-a-way!"



# THE HILL OF ADVENTURE

By ADAIR ALDON

## SYNOPSIS OF PREVIOUS INSTALMENTS

IN the small town of Ely, in the Rocky Mountains, Beatrice Deems, her sister Nancy, and their Aunt Anna settle down for the summer. The town is full of foreign laborers who, led by a Finnish agitator, Thorvik, begin rioting when the irrigation company that employed them ceases work for lack of funds. Finding Ely untenable, Beatrice moves the household to a cabin on the mountain-side. They are helped by Thorvik's sister Christina, whose son Olaf is a sailor at home on leave, but who dare not go near the village on account of a mischievous prank he played before he went to sea. The cabin's nearest neighbors are John Herrick, the head of the irrigation company, and his adopted daughter Hester. A would-be reporter and amateur detective, Dabney Mills, is seeking to solve the mystery of why the irrigation company is without funds when it had seemed so prosperous. Dr. Minturn is a friend who lives on the other side of the mountain. The girls' invalid aunt finally breaks her long reticence and tells them the reason of their coming to Ely—the hope that she may there find some trace of her brother Jack who, thinking that his family suspected him of dishonesty, broke with them and vanished ten years before. The girls believe that John Herrick is this brother, but do not tell their aunt, fearing to raise false hopes. Dabney Mills confides to Beatrice that he believes the irrigation company's funds have been made way with by John Herrick. He does not shake her confidence in John Herrick, however, but she goes over the mountain to seek advice from Dr. Minturn. As she and Nancy are returning together, they find John Herrick, badly hurt by a fall, on a precipitous stretch of trail known as Dead Man's Mile. A furious storm is sweeping down upon the mountain; he begs the girls to leave him and seek shelter in the valley below. Beatrice refuses to go.

## CHAPTER XV

### "OLD FRIENDS AND OLD TIMES"

A RIDERLESS brown pony, very cautious and very wise, stepping carefully from ledge to ledge, testing his footing and picking his way with the greatest skill, was the messenger upon whom depended all hope of safety for Beatrice, Nancy, and John Herrick. Tucked under his stirrup leather was a note that Beatrice had scrawled hastily on the scrap of paper that had wrapped their sandwiches. It was addressed to Dr. Minturn and told where they were and how desperate was their need. She knotted the bridle reins on Presto's neck, turned up the stirrups over the saddle, given him a slap on the flank, and told him to "go home." Every well-trained Western horse knows that order, and will find his way over the steepest trails, back to his own stable; nor will he allow himself to be stopped or molested on the way.

"It is lucky we had Presto," Beatrice said to her sister. "Buck or your horse would have taken twice as long to get home, and Hester and Aunt Anna would be so frightened, though Olaf would have known what to do. As it is, they won't worry, for I said I might stay another day. I wonder how soon help can come."

John Herrick, lying very still among the blankets, made no comment. They began to realize that he had summoned all his strength to pretend that he was not much hurt and to persuade them to leave him. It was plain that he was suffering intensely

and was resting before trying to go on with what he had to say.

"Unsaddle Nancy's pony," he directed at last, "and turn him loose. Without his saddle, he will know he is turned out to graze and will not go home. He will drift down the mountain and find shelter somewhere in the timber."

The sides of the tent flapped and quivered in the eddies of wind as the gale began to blow heavier. Under John Herrick's directions, they rolled stones on the edge of the canvas to keep the blast from creeping under it, and laid larger logs of wood at the back of the fire to make a slower, steadier blaze.

The smoke of the fire, with most of its heat also, was tossed and whirled out into the void, but they were able, finally, to hang up a spare tarpaulin to reflect the warmth into the tent. The site of the camp had been chosen wisely, for it was sheltered by a high shoulder of rock, with a nook between two stones to hold the fire, and a small stream pouring over a cliff near by. Yet even in this corner, there was not complete protection from the roaring wind that was beginning to carry the first flakes of snow. More than once, Beatrice saw the injured man's eyes turned anxiously toward the pile of fuel, gathered in abundance for ordinary purposes, but pitifully small for the need that had now arisen. She knew that he would not tell them of the necessity for gathering more, since to seek for fire-wood on that wind-swept mountain was a dangerous and difficult task.

"Go into the tent and talk to him, Nancy; keep him looking another way," she whispered, as she fed the blaze. "I am going down the trail a little way to cut some brush."

Taking up the small ax from where he had left it beside the fire, and turning her coat collar up to her ears, she slipped away before her sister could protest.

The wind whipped about her the moment she passed beyond the sheltering rock, buffeting and blinding her until she thought she would be flung from the ledge. She believed she had never felt such piercing cold. It cut through her coat and made her fingers and feet ache in a moment. Valiantly she struggled forward, getting her bearings gradually and peering this way and that through the driving snow to find the fuel that was so desperately needed. Among the tufts of scrubby bushes that clung here and there to the stony slope, it was difficult to find anything dry enough to burn. Nor was it easy to cut through the tough, fibrous stems that clung to the mountain in defiance of so many storms. The brisk exercise warmed her, however, and the armfuls of brush that she carried back and heaped by the tent began to grow encouragingly high.

It was in the effort to cut a little juniper-bush, at the outer end of a narrow ledge, that she leaned too far, felt the ground crumble under her feet, and, after a sickening moment of clinging to a projecting root with bleeding, frantic hands, finally dragged herself back to safety. Below, in a great well of shadows, she peered down and down, but could see nothing and could only hear the tinkle of the ax as it struck a stone far below. But she brought away the juniper-bush and once more struggled up the path to the tent.

"I thought you were never coming back," said Nancy; and John Herrick opened his eyes to look at her with troubled questioning.

"I was just getting some brush for the fire," she told him cheerfully. "I took your ax and I—I did n't bring it back with me."

His observant blue eyes went over her from head to foot, and his face, drawn with pain, lightened to a smile. When he spoke, at last, it was so low she had to stoop down to hear.

"Have I not enough to blame myself for, without having to see some terrible thing happen to you here on this cruel mountain? I am proud that you belong to me, you and that blessed, warm-hearted Nancy. Can you ever forgive me?"

"Forgive you for what?" she asked.

"For all that I have done."

She could not trust herself to answer, and there was a pause before he spoke again.

"I am better now," he declared at last, trying to smile reassuringly upon them both, although the color of his face, ghastly white under the sunburn, belied his words. "I want you to sit down and tell me—" his voice faltered, but in a moment he went on again,—"tell me about Anna. Is she getting well? How long has she been ill? Did she really come here to—to—"

His voice trailed away to a whisper, but Beatrice knew what he wished to ask.

"She came to find you," she answered. "You shall hear all about it. No, don't move, it will make your arm begin to bleed again. Lie still and we will tell you everything."

With the wind howling over their heads, but with the slow heat of the fire keeping the worst of the cold at bay, they sat there by him and told the whole of their tale. Sometimes one of them would get up to throw more fuel on the dwindling flame, and the other would take up the story in the interval. Now and then he would ask a half-audible question, but mostly he lay quite quiet, his steady eyes—how like they were to Aunt Anna's!—fixed upon the face of the girl who was speaking. When the account was finished, he had various things to ask, often with long pauses between the words.

"Do you live in the same house—it was the one where your father and Anna and I were born? Does Bridget Flynn still stay with you? Which of you sleeps in the blue room, where, on stormy nights, you can hear the rain in the big chimney?"

Yes, they lived in the house he knew; Bridget Flynn, the old nurse who had cared for them all, was not with them, but was still alive. Beatrice had the big south room; it was green now, but the rain in the chimney was just the same.

"How it all comes back!" he said with a sigh. "And to think that I have been such a fool as to believe that I could put behind me all that I loved so much!"

His voice failed after that, and his questions ceased. They could hear his faint breathing and feel the thin, uneven pulse in his wrist; but he did not move or give other sign of life. The night had closed about them; the storm was blowing still louder, and the cold growing more intense. Snow was piling about the tent, eddying through the opening, lying in white streaks even among the folds of the blankets.



They crept back to the fire, at last, both of them wondering miserably at the heaviness of his stupor, but trying to assure themselves that it was really sleep. Very closely they huddled together, sharing the single blanket that was wrapped about them, saying little, but thinking very much.

"Aunt Anna will be going to bed now," Nancy observed, after such long quiet that Beatrice had thought she was nodding. "Christina will be lighting the lamps and tucking in the fur rugs on the sleeping-porch."

Since Beatrice scarcely answered, but sat staring, though with unseeing eyes, at the red coals, Nancy spoke again. "Are you cold, Beatrice? Are you afraid? How soon do you think help will come?"

"It will come soon," her sister answered confidently. "No, I am not cold and I am not afraid."

Nancy, willing to be reassured, crept closer and allowed her heavy eyelids, weighed down by drowsiness, to fall lower and lower. Beatrice, however, sat erect and wide awake. She was counting the number of hours before Dr. Minturn could get her message, calculating the time their fuel would last. By midnight the final log would be burned, the last bundle of brush would have gone up in wind-swept sparks. And what was to come when the fire was dead?

She felt strangely quiet, in spite of all the dread possibilities before her. She thought over, one by one, all the events in that long, twisted chain of circumstances that had brought her here, and realized all that she had learned, how much she had changed. Could it be possible that she had once been so absorbed in her own affairs, in the pleasures and interests of her single, restricted circle, as to have been blind to her father's anxiety and to Aunt Anna's slowly breaking heart? She had lost all that old narrowness of vision; she had left behind, also, that restless discontent and nameless dissatisfaction that used suddenly to spring up in the midst of the careless happiness of the old life. Even when they first came to live in the cabin, she had been filled with anxiety and the weight of unfamiliar responsibility; but such misgivings had disappeared also, blown away into the past by the winds of Gray Cloud Mountain. Here she had learned new things, felt new strength, had begun to play a part in the real affairs of life.

Nancy, leaning against her, had dropped sound asleep, and Beatrice herself must have

dozed at last. Her last clear thought had been of Dabney Mills. Even the puzzle of his suspicions would be solved at last, she felt sure. But why had he thought—?

Her eyes closed, opened again with a start—upon a different world. She could not tell how long a time had passed. The storm was over, the moon was up, and the whole mountain-side was bathed in light. Leaning forward, she attempted to look down into the valley, and was surprised to see no valley there. A level floor of clouds, as smooth as the surface of a lake, but of a strange, shadowy whiteness that no water could ever show, lay below her, a flood of mist that filled Broken Bow Valley to the brim. Fascinated, she sat watching, while the moonlight grew clearer and the soft white turned to glistening silver. Although she thought herself awake, she dozed again, for she had a dim idea that she could walk forth on the smooth level of that white floor, past the mountain-tops, straight away toward the moon; while all the time another self sat cold and nodding by the fire, feeding the failing flame mechanically, with one arm around the slumbering Nancy. Vaguely she knew that complete oblivion would mean the end of the fire, the quenching of the warmth that kept them alive, and of the light that was to be a signal to their rescuers.

How she longed to lay down her head and give herself up to slumber! How far away her dream was carrying her, out across that white sea whose farther edge seemed to roll across the peaks and break against the stars! Some inward spirit kept her faithful to her task, even after real consciousness had vanished. When she did give up to heavy slumber, it was only when her work was done, when her drowsy ears heard afar the chink of iron hoofs upon the trail, heard the scrambling of feet and the sound of men's voices coming nearer.

"They are coming—they see us!" she thought, and her head dropped upon her arm in absolute exhaustion.

It must have been only for a moment that she slept, although it seemed that hours must have passed, when she awoke with a jump to a bewildered confusion of sights and sounds. The red light of a lantern was flashing in her face, the huge, grotesque shadow of a horse's head danced back and forth on the rock wall beside her, and Dr. Minturn's voice sounded in her ear:

"Beatrice, are you safe? Are you alive?"  
Dazzled and confused, she rubbed her

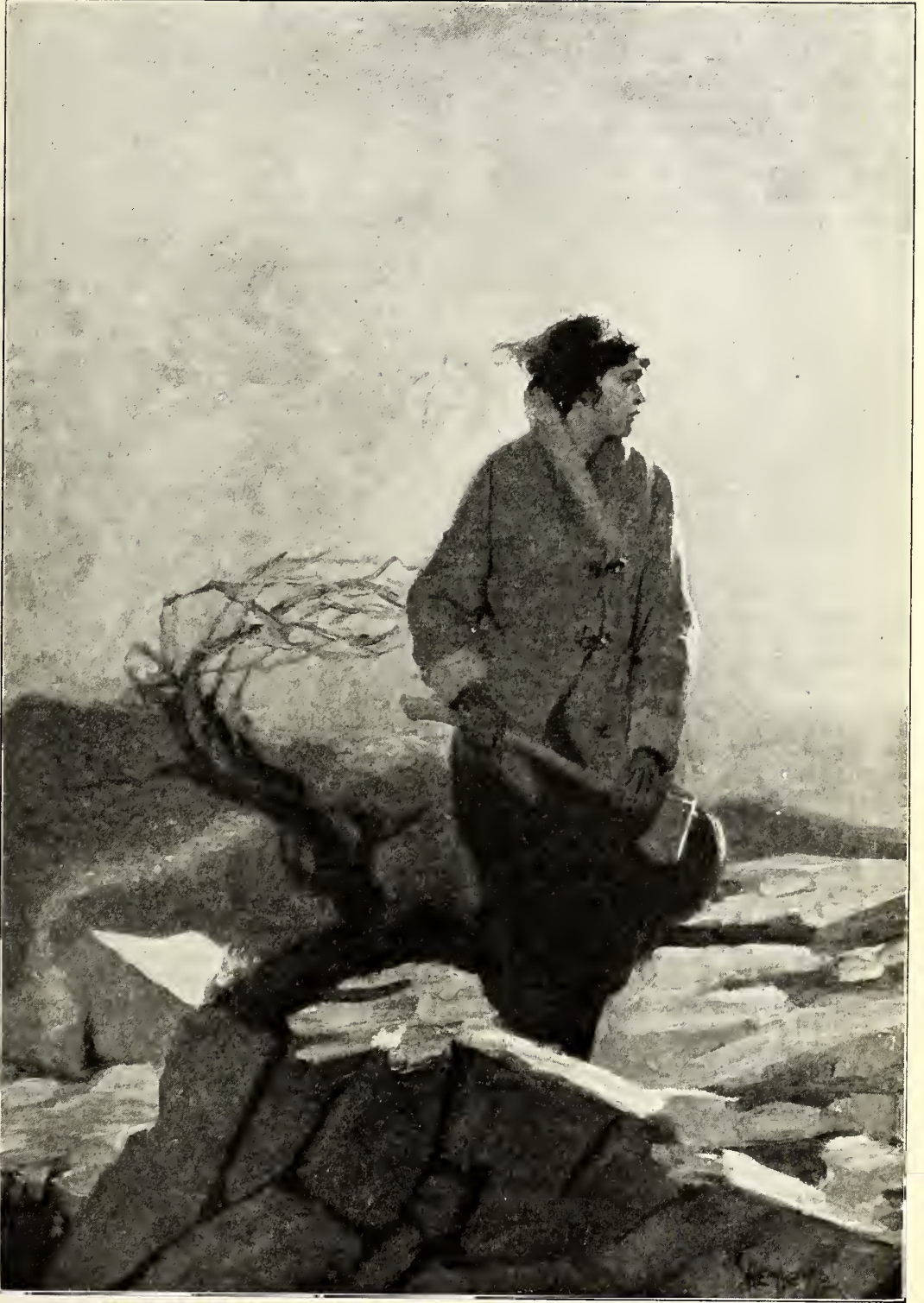

"IT WAS DIFFICULT TO FIND ANYTHING DRY ENOUGH TO BURN"



eyes, then motioned toward the tent where John Herrick lay, since words of explanation would not come quickly enough. She held her breath, so it seemed to her, through all the minutes that the doctor was bending to examine the unconscious man. When he straightened up again to speak to her, how comforting it was to hear that big voice booming out, where the last sound had been John Herrick's failing whisper.

"He has gone a long way," the old doctor said, "but, please Heaven, we 'll bring him back again."

## CHAPTER XVI

### HASTY WORDS

IN the gray light that is the ghost of morning, a fantastic procession went slowly down the headlong slope of Dead Man's Mile. The tall doctor strode ahead with his swinging lantern, and behind him came the two men he had brought, carrying John Herrick between them upon a litter of blankets. Nancy, following them, clung fast to her pommel, and was glad that the saddle was so deep that she could not well fall out of it no matter how the doctor's pony, upon which she was mounted, swayed and slid down the rough path. For guidance, her mount was left almost as much to himself as was the extra horse following at the end of the line, whose nose was close to the tail of the pony that Beatrice rode, and whose footsteps were guided by the second lantern that bobbed and jerked from her saddle-bow.

"It was the next thing to impossible to climb up in bright daylight," Beatrice thought. "How can we ever go down in the dark, with a helpless person to carry?"

But the doctor had declared that further delay meant too much danger to John Herrick and that the attempt must be made. So down they went, past the rocky shelf where the girls had found him, over barriers that looked impassable, down steep declivities that were nothing but wells of blackness and hidden danger. A word of direction from the doctor, a breathless squeak from Nancy once when her horse lurched suddenly beneath her, the steady scuffle of the ponies' feet, those were the only sounds. They had passed the icy shallows of the tumbling stream; they had looped down over the jutting shoulder of smooth rock where there was scarcely a foothold; there was a long, stiff-legged jump for each pony, and they were down.

Through the rustling underbrush of the

lower slope, the main trail leading downward from Gray Cloud Pass was firm under their feet.

"Looks like Broadway, don't it, after that squirrel-track back yonder," observed one of the men, as they stopped to rest for a little. The other man went to catch Nancy's pony that had been turned loose before the storm and that now came, stamping and snorting, through the dark, drawn by the lantern light and by the desire for company of its own kind.

It was possible to carry the litter between two horses now, so that the doctor mounted, left one man to follow on foot, and ordered them all to press forward. A moving shadow in the darkness proved to be John Herrick's black mare that had managed to scramble to her feet and stood, with head drooping and one leg helpless, beside the path.

"We can't stop for her now," the doctor said. "I will send some one back, to see if there is anything to be done."

So the poor creature was left behind, although Beatrice leaned from her saddle to touch the soft, anxious nose that was thrust out to her and although a pleading whinny could be heard long after the darkness had swallowed up the injured horse.

They went on steadily and quickly now, with Beatrice nodding in her saddle from unbelievable weariness. They were fording a stream; they were threading the grove of aspen trees; they had reached the last mile of their journey. The whispering leaves were all speaking together in the morning breeze; the birds were beginning to sing; the darkness had faded so that the light of her lantern had shrunk to the pale shadow of a flame. She looked back to see the bare granite slope above her turn from gray to rose, and to see the stark summit of Gray Cloud Mountain shine in sudden silver radiance as the sunrise touched it. Almost immediately she saw the men ahead of her stop, dismount, and lean over the litter.

"He is awake and I think he wants you," one of them said to Nancy, but she listened and shook her head.

"He is not really conscious," she answered, "and it is my Aunt Anna that he is asking for."

It was a week, a dragging, interminable week, before any one was able to know just what were to be the results of that fateful expedition up the slopes of Gray Cloud Mountain. Nancy, stiff and aching in every muscle from so much unwonted riding, was the first to recover and to set about her housekeeping.

Beatrice had sprained her knee in that perilous moment when she dropped the ax over the mountain-side, but had scarcely noticed the mishap until, slipping from the saddle at her own door, she found herself unable to walk into the house. For three days she was almost helpless; by the end of seven, however, she was able to limp about the house and help Nancy and Christina with their work.

Christina had come to stay at the cabin so that the girls might not be alone, for Aunt Anna had moved to John Herrick's house. It seemed, at first, that she had found her brother only in time to part with him again, for through four terrible days he lay so ill that not even Dr. Minturn could give much encouragement. Perhaps no one knew, until that dreadful time, how brave Aunt Anna could be. It was she who was cheerful; it was she who was hopeful and kept up the courage of the others; it was her tired, white, but smiling face upon which John Herrick's eyes fell when he opened them to consciousness again.

The three girls were standing in the door and Dr. Minturn was with them, but it was only his sister that John Herrick saw.

"Anna," he whispered, "I have had a bad dream, I think."

"Yes," she nodded gravely; "we have all been dreaming, but at last we are all awake."

His eyes went to the window where, in the hot sun of brilliant noonday, the moving tree-tops showed their densest green and the far mountains stood blue against a bluer sky. He looked doubtful for a moment, as though he had expected to find himself in his old home, in that room where the rain in the chimney had lulled him to sleep through childhood nights. When he remembered all that had happened since, would he shrink away again into that isolation he had made for himself? They could actually see, from the changes in his face, just how the flood of memories rose and swept over him, recalling everything, from his accident on the hill, back to that day when he had vowed to shut the door of home behind him forever. At last he turned to his sister again and smiled.

"I thought I could never forgive all of you," he said; "and it was you, this whole long time, who should have forgiven me. Through all these years I have been remembering how I went away, how I looked into that row of serious faces and thought I read doubt in every one of them. Yes, Anna dear, I know you believed in me still; I know you called after me; but I vowed it was too

late. I heard your voice as I closed the door; it has followed me ever since—but I would not listen. Can you forgive me?"

The girls slipped away, and Dr. Minturn closed the door.

"He 'll do," he said gruffly. "He won't need any doctor to cure him now."

A man who has spent the last ten years in the free open and the bracing air of the Rocky Mountains does not linger long upon a sick-bed when once he has begun to recover. John Herrick was sitting up in a week's time, and was able to limp about at the end of ten days. As his strength grew, so did Aunt Anna's, and step by step, they came along the road of health together.

"Is n't she wearing herself out, nursing him?" Beatrice asked Dr. Minturn anxiously.

But he only laughed. "It never harms people to do what they like most in the world," he answered. "I can hardly tell which of the two is getting well the faster. They have no further need for me, so I will be getting back to Miriam. I can leave the whole affair in your capable hands, Miss Beatrice."

Beatrice laughed, yet flushed with pleasure that the doctor should voice such confidence in her. She could not help feeling a little thrill of pride when she thought of how well things were turning out. Even the black mare was hobbling about the corral, giving promise that she could be ridden almost as soon as John Herrick would be able to mount her. There was still the affair in the village to be made clear, but of that Beatrice had thought very little lately, and not at all of Dabney Mills.

A growing restlessness on Christina's part was the first reminder of what was going on about them.

"I don't want to go," she explained when, on Aunt Anna's returning to the cabin, Christina announced that she was needed at home; "but I am anxious when I am away from Thorvik. I never know what new things he is thinking up."

She had waited to wash the evening dishes, lingering over them as though she were unwilling to finish, but she had said a reluctant good-by at last and gone away down the hill. Beatrice sat on the door-step looking after her, and lingered long after she was gone, watching the darkness deepen between the tree-trunks and the fireflies move to and fro. It had been an overbusy day, with the result that she was very tired. It was surely the worst possible moment that Dabney Mills



could have chosen to come striding through the dark, whistling with irritating shrillness.

"There are all sorts of rumors about John Herrick's being hurt," he began at once, "so I came up to see if I could get the real facts. I tried to interview the old doctor when he was down in the village, but I did n't have much satisfaction."

On that very spot, Beatrice thought, he had been told once, twice, it was difficult to say how many times, that his presence was unwelcome and that he would be told nothing. Yet here he was again, as inquisitive and as well assured of success as ever.

"I don't see why you keep coming and asking things," she said, "when we never tell you anything."

"A fellow can never tell," he replied easily, "where he can pick up a few facts, even in the most unlikely places. I won't say this is a very hopeful one, but there 's nowhere else to go. I hear your aunt has been nursing Herrick. Now I could make something very interesting out of that."

His insinuating grin, half visible in the dark, was suddenly quite beyond bearing.

"Why should n't she be nursing him when she is his own sister?" Beatrice cried hotly, a sudden burst of temper driving her quite beyond the bounds of prudence.

Dabney's mouth was opened to speak, but no words came, only, after a moment, a long whistle of astonishment.

"Sister!" he ejaculated at last; then repeated it to himself, "sister!" Beatrice said nothing, for she began to have an uneasy feeling that harm might come from her hasty speech.

"But look-a-here," Dabney Mills burst out; "if she 's his sister and he 's your uncle, why did you never let on to any one? You were strangers to him, you two girls, when you came here—I could swear it. And one day, when you were out, I asked your aunt if she had ever seen John Herrick and she said no."

Still Beatrice was silent, with growing misgivings, as he went on excitedly, as much to himself as to her.

"There must have been a family quarrel," he speculated shrewdly. "Herrick did something disgraceful, most likely, back there at home, and came West to lose himself, and the rest of you followed, by and by, to see him; but you never owned he belonged to you. Say—that 's something to tell them down yonder at the meeting to-night. They won't be saying then that I never find out anything. When the men hear that about his past, they will know for sure where to look for their money."

He swung on his heel and was off in haste down the hill.

"Stop—stop!" cried Beatrice; but he paid no heed. She ran a few steps after him, but he had already disappeared.

*(To be concluded)*

## THE SUMMER WORLD

By MRS. SCHUYLER VAN RENSSELAER

SWEET, O, sweet, O, high up in the tree,  
Sing, bird, sing, your very best for me!

White, O, white, O, high up in the sky,  
Sail, cloud, sail, I watch you sailing by!

Far, O, far, O, sparkling in the night,  
Burn, star, burn, for me your golden light!

Ripple, O, ripple, O, the meadow grasses through,  
Run, brook, run, and I will run with you!

I know, I know—all the things I see,  
All of them, all, were meant to play with me!



"THE ROSE." PAINTED BY LYDIA FIELD EMMET



# THE INCA EMERALD

By SAMUEL SCOVILLE, JR.

## SYNOPSIS OF PREVIOUS INSTALMENTS

PROFESSOR AMANDUS DITSON, the great scientist, has discovered the location of Eldorado, where for hundreds of years the Incas of Peru threw the best emeralds of their kingdom into the lake as an offering. The professor's ambition in life is to secure a living specimen of the bushmaster, the largest and most venomous of South American serpents. He calls on Big Jim Donegan, the lumber-king and gem-collector, and offers to lead a party to the lake if Jim will finance the trip, and to allow the lumber-king to have the emeralds, provided Ditson can keep the bushmaster. Jim promptly agrees to this, and Jud, the old trapper, Will, and Joe, the Indian boy, who together found the Blue Pearl for Jim Donegan, agree to go on the trip. Jud and Professor Ditson bicker as to who shall lead the expedition. A whip-scorpion decides the discussion in favor of the professor. They hear and see strange and beautiful birds in the forest, and Jud gets tangled up in a multitude of thorny vines and shrubs and has an adventure with a trail-haunting black-snake. The party enjoys wild milk and honey, and Will studies the tropical butterflies. At night, in a deserted house, vampire-bats break through the screen and get into his room and he is badly frightened and bitten. The party travel by steamer to Manaos, the hottest city in the world. There they change to an Indian boat and travel down to Black River, which they enter by night, contrary to the Indian superstitions. Joe has a terrible experience with an anaconda, and Will is nearly swallowed by a giant catfish. They pass Treasure Rock and hear its story. Attempting to run the rapids of Black River, they are shipwrecked, and only escape to the bank with much difficulty, losing all of their equipment. They have an adventure by night with a jaguar, which Professor Ditson frightens away. Pinto, the Indian, makes for himself a blow-gun and the fatal urari poison; and under his direction, the party builds a new boat and starts on down the river.

## CHAPTER VI

### THE BLACK TIGER

UNDER Pinto's direction, the hollow trunk was lifted up so that either end rested on a stump. Then a slow fire was kindled under its whole length. Pinto tended this most carefully, so that the heat would spread evenly. Gradually, under the blaze, the green wood spread out. This was the most critical point in this forest boat-building, for if there were too much heat at any one point, a crack might start through the log and all the work of the week go for nothing. As the great log opened out, the Indian moved constantly up and down its length, checking the blaze here and there with wet moss where the sides were spreading out too fast. At several different points he fitted in straddlers, with wedges made from stonewood branches. By skillfully changing the pressure with these and varying the heat at different points, the hollowed log at last took on a graceful curve, with tapered turned-up ends. Green strips of stonewood were fitted in for gunwales, and seats and semicircular end-boards put in place. Then the long dugout was allowed to cool off gradually all through one night. As it contracted, it locked in place gunwales, seats, and thwarts. Another day was given to fashioning long light paddles out of palm-wood; and then at last, one week after their shipwreck, these latter-day Argonauts were once more afloat upon Black River.

There followed long days, in each of which

three seasons were perfectly reproduced. The mornings had all the chill of early spring; by noon came the blinding heat of mid-summer; and the nights, of the same length as the days, had the frosty tang of autumn. During the morning of each day they paddled, laying by at noon-time in cool, shaded lagoons where they slept or fished. At other times they would collect nuts and fruits on the shore, under the direction of Professor Ditson, or take turns in going with Pinto on short hunting-trips, during which all kinds of strange game would fall before his deadly blow-gun.

It was Jud who went with him on the first of these hunts. As they came to the bank of one of the many streams which ran into Black River, the old trapper caught sight of a strange animal on the bank which looked like a great guinea-pig about the size of a sheep. Its wet hide was all shining black in the sunlight, and even as Jud turned to ask the Indian what it was, there sounded just behind him the fatal pop of the blow-gun, a venomous little arrow buzzed through the air, and a second later was sticking deep in the beast's blunt muzzle. Like an enormous muskrat, the stranger scrambled to the edge of the stream, plunged in, and disappeared in the dark water.

"That was a copybara," Pinto informed Jud.

"Well, you've lost him all right, whatever he was," returned the latter.

"Wait," was all that Pinto would say.

A few minutes later, the limp, dead body of the capybara, the largest of all aquatic rodents, floated to the surface. Jud was about to wade into the shallow water and secure it, when he was stopped by the Mundurucu.

"Never put your hand or foot into strange water," he said. "You may lose 'em."

Without explaining himself, he cut a long pole and carefully towed the dead animal to shore. That night the whole party camped on a high, dry, sandy bluff where Pinto and Hen dressed the capybara and roasted parts of it on long green spits of ironwood. Will sampled the dank, dark meat cautiously.

"Tastes like a woodchuck I once tried to eat," he remarked, after one mouthful. "You can have my share." And he went back to palm-nuts.

From another trip, Pinto brought back a coaita, one of the spider-monkeys which had so affected Will's appetite on the occasion of their first meal at Professor Ditson's house. This one had a long, lank body covered with coarse black hair, while its spectral little face was set in a mass of white whiskers. Will ate the rich, sweet meat shudderingly.

"It looked just like a little old man," he protested.

"But it tastes better," observed the hardened Jud, passing his bark plate for a third helping.

It was Jud and Will who accompanied Pinto on the third and most eventful trip of all. The boat had been beached at the slope of a high bank; and while the others dozed or slept, Pinto and his two companions started through the woods on their hunt for any game which might add some kind of meat to their menu. A hundred yards from the bank the jungle deepened and darkened. Everywhere the strangling-fig was killing straight, slim palms and towering silk-cotton and paradise-nut trees. At first, this assassin among the tree-folk runs up its victim's trunk like a vine. As the years go by, it sends out shoots and stems around and around the tree which it has chosen. These join and grow together, forming a vast hollow trunk, in the grip of which the other tree dies. Pools of black water showed here and there at the foot of the strangled trees, and something sinister seemed to hang over this stretch of jungle.

"Feels kind of creepy here," Jud confided to Will. "Looks just the kind of a place for some of Hen's haunts," he went on.

Even as he spoke, there sounded among

the distant trees ominous grunting groans, and here and there among the shadows dark shapes could be seen moving about. The fierce moaning grew louder, mingled with a clicking noise like castanets.

"Peccaries!" muttered Jud. "I've hunted the little ones down in Mexico. They were liable to bite a piece out of you as big as a tea-cup. I'm in favor of lettin' these big fellows strictly alone."

"Quiet, quiet!" muttered the Indian, slipping behind a tree and motioning his companions to do likewise. "They go by in a minute, and I take off the last one with my blow-gun."

Instead of doing this, however, the great herd spread out through the woods, grunting and groaning and clattering their sharp tusks. As they came closer and closer, each of the peccaries seemed nearly as large as the wild boar of European forests, while their lips and lower jaws were pure white. The Mundurucu showed signs of alarm.

"Something has stirred them up," he muttered. "If they see us, they charge. Better each one choose a tree."

Even as he spoke, the leading peccary, whose gleaming tusks thrust out like keen knives from either side of his white jowl, glimpsed the little party in the shadows. With a deep groan, he lowered his head and charged at full speed, his tusks clattering as he came, while the white foam showed like snow against the raised bristles of his back. The whole herd followed—a nightmare of fierce heads, gleaming red eyes, and clicking, dagger-like tusks. Against such a rush, Jud's automatic was as useless as Pinto's blow-gun or Will's throwing stones. There was only one thing to do, and, with the utmost promptness, all three of the party did it. Jud went up the vine-like trunk of a small strangler-fig hand over hand, nor ever stopped until he was safe astride the branch of a stonewood tree, twenty feet from the ground. Pinto, gripping the rough red bark of a cow-tree walked up it Indian fashion until he was safely seated in a crotch far above the ground. Will was not so fortunate. Near him was the smooth bark of an assai-palm. Twice he tried to climb it, and twice slipped back. Then, with every muscle tense, he dodged behind it and sprinted, as he had never run before, across a little opening to where a vast strangler-fig had swallowed a Brazil-nut tree in its octopus grip. The rush of the charging herd was hard on his heels as he reached the tree, and he had



just time to swerve around its trunk and grip one of the vine-like tentacles which had not yet become a part of the solid shell of the strangler. Even as he swung himself from



THE UMBRELLA-BIRD, WHICH RAISES ITS "PARASOL" WITH EVERY NOTE

the ground, the bristling head of one of the herd struck against his feet, and he kicked them aloft just in time to avoid the quick double slash of the sharp tusks which followed. Up and up he went, while the whole shell-like structure of the fig swayed and bent under his weight and dry dust from the dead

nut-tree powdered down upon him in showers. Finally, he reached a safe resting-place where he could stand with both feet resting in a loop which the snake-like fig had made in one of its twisting turns around its victim. For a few moments the trio in the tree-tops sat and stared in silence at each other and the weaving, champing herd of furious beasts below. It was Jud who spoke first.

"It's your move, Captain Pinto," he remarked. "What do we do next?"

"Sit still until they go away," returned the Indian, despondently.

"How many arrows have you left?" inquired Will from his tree.

"Ten."

"I've got sixteen shots in my locker," observed Jud, from his perch; "but there must be nearly a hundred pigs in this herd; an' if these big fellows are like the little chaps I knew in Mexico, the more you kill, the more those that are left will try to kill you."

"The only thing to do is to sit still," repeated the Mundurucu. "Perhaps they go way before night."

"Perhaps they don't, too," grumbled Jud. "A pig's an obstinate critter at his best, an' a peccary is a pig at his worst!"

As time went on, conversation among the besieged flagged and each one settled down to endure the wait as best he might. Will amused himself by watching the birds which passed him among the tree-tops and listening to some of their strange and beautiful songs. At any time of the year and in any part of the world, a bird-student can always find pleasure in his hobby where unseeing, unhearing people would find nothing of interest. To-day the first bird which caught his eye looked something like a crow, save that it had a crest of curved, hairy feathers, which at times, on its perch in a neighboring tree, it would raise and spread out over its head like a fringed parasol. From its breast swung a pad of feather-covered flesh, and, as it perched, it would every now and then give a deep, low, flute-note, raising its parasol each time in a most comical manner.

"What's that bird, Pinto?" Will inquired, after he had watched it delightedly for a long time.

"He umbrella-bird," returned the other, indifferently; "no good to eat." For the Mundurucu had a very simple system of ornithology—he divided all birds into two groups, those that were good to eat and those that were not.

The next bird that passed by aroused the

interest even of Jud, who cared even less for birds than did the Indian. Through the dim light of the sinister forest, above the raging, swinish herd, flitted a bird of almost unearthly beauty, a parrot over three feet in length, of a soft, hyacinthine blue except around the eyes, where the bare skin showed white. As Will watched it delightedly, he recognized the bird as the hyacinthine macaw, the largest, most beautiful, and one of the rarest of all the parrot family. Even as he looked, the great bird alighted on a neighboring Brazil-nut tree and immediately showed itself to be as efficient as it was beautiful. Seizing in its great black beak one of the tough, thick nut-cases, called "monkey-pots" by the Indians, it proceeded to twist off its top and open up a side, although a man finds difficulty in doing this even with a hammer and chisel. Drawing out one Brazil-nut after another, it crushed them, in spite of their hard, thick shells, into a pulp, which it swallowed. Then it flew away, leaving Will staring regretfully after it.

As noon approached, the vines and the tree-trunks seemed to hold and radiate the heat like boiler-tubes. Gradually it rose and concentrated until the forest seemed to throb and pulsate like a furnace. Then a cicada began to sound. It began with a low, jarring note, something like the creaking of our ordinary katydid. This increased slowly in loudness and volume until at last it ended with an almost unendurable siren-whistle note which seemed to shake the very leaves of the trees. Again and again and again this performance was repeated, until Will, deafened and stunned by the noise, dizzy with the heat, and cramped and tired of standing on his narrow perch, thought with an almost unutterable longing of the dark, cool river and the shaded boat where the rest of the party were even now taking their noontide nap.

Suddenly, when it seemed to Will as if his tortured brain absolutely could not stand one more repetition of this song, the talented cicada, with one farewell screech that surpassed all previous efforts, laid off for the day. For a few minutes, there was almost complete silence in the darkened forest. Many of the guardian herd had laid down, wallowing in the soft mold and fallen leaves, while others, although they stared redly up into the tree-tops, no longer moved around and around in a circle of which the trapped hunters were the center. Suddenly, from the depths of a near-by tree, a pure, sweet,

contralto voice sounded, as if some boy were singing to himself. For a moment it rose and fell, and then followed a few plaintive notes almost like those of a tiny flute. Then



THE HYACINTHINE MACAW, WITH A "MONKEY-POT" OF BRAZIL-NUTS

a slow melody began, full of mellow notes, only to be broken off abruptly. After a pause, there came a few clicking notes like those made by a music-box as it runs down, and the performance was over. Although the song came from the dark, glossy leaves of the very next tree, stare as he would, Will



could gain no sight of the singer. Twice more the same thing happened. Each time he listened with a feeling that this time the tune would be finished and would be such as no mortal ears had heard before, but each time the song would die away in futile clicking notes. When at last the silence was again unbroken, Will turned toward the Indian.

"What was it, Pinto?" he asked softly. "That organ-bird."

"What does it look like?"

"Don't know. No one ever sees it."

"How do you know it 's a bird?"

"Professor Ditson say so," returned Pinto, conclusively.

"That settles it," broke in Jud, jealously, from his tree. "He never saw it; nobody ever saw it; but the professor calls it an organ-bird. If he said it was an angel, I suppose it *would* be an angel."

"Yes," returned the Indian, placidly.

The argument was suddenly ended for Will in a terrible manner. A sharp, burning pain shot through his left shoulder, as if a red-hot coal had been pressed there. As he turned, he saw, trickling down the tree-trunk, long, crimson streams, one of which had already reached him, and he recognized to his horror a troop of the dreaded fire-ants. Even as he looked, the bites of several others pierced his skin, and the pain ran like liquid poison through his veins as each blood-red ant rushed forward and buried its envenomed jaws deep into his flesh. Brushing off with frantic haste those torturers which had succeeded in reaching him, the boy began to slip down the vine toward the ground, for it was no more possible to resist this red torrent of poison and agony than it would be to stand against a creeping fire or a stream of molten lava. Old Jud heard the involuntary cry which the sudden pain had wrung from Will, and looked over, only to see the red columns of ants streaming slowly, inevitably down the tree, driving Will before them to what seemed certain death. The peccary herd, aroused by his movements, had gathered around the tree in close-packed ranks, and, frothing, clattering, and moaning, waited for him, making a circle of gleaming tusks.

"Go back!" called out Jud. "Go back! You can't possibly get through 'em."

"I can't!" called back Will. "I'd rather die fighting than be tortured to death up here."

As he spoke he slid another yard toward the ground. Jud drew in his breath in a gasp that was almost a groan, and, unsling-

ing his ready automatic, began to scramble down to the ground.

"What you do?" called out the Indian, aghast, from his tree.

"I 'm a-goin' to stand by that kid," said the old trapper, grimly. "I 'll never go back to the boat alive without him."

"Stay where you are, Jud," shouted Will, desperately, as he gripped the keen hatchet which he had borrowed from Joe when he started on this ill-omened hunt.

"Come on, boy!" shouted the trapper, unheedingly, as he neared the ground, "I 'll meet you, an' you fight through them to my tree. The old man 's a-goin' to be right with you."

His words were punctuated by the deadly pop of Pinto's blow-gun. Although the Indian could not attain to Jud's height of self-sacrifice, yet he had made up his mind to do all that he could to save the boy with the weapon which he had. Again and again and again, as fast as he could level, load, and discharge his long blow-pipe, the fatal little arrows sped through the gloom and buried themselves in the thick hides of the peccaries. Already some of the inner ring were wavering and staggering under the effects of the deadly urari poison. The sight of their stricken comrades, however, only seemed to drive the herd into deeper depths of dumb, unreasoning madness. They pressed closer and closer to the tree, trampling their dead and dying comrades unheedingly underfoot, and the chorus of moaning grunts and clicking tusks sounded loud and louder. The blood-red stream of fire-ants was half-way down the tree by this time and Will was within a scant ten feet of the ground. The red stream was very close as he lowered himself another yard, then a foot lower, and a foot beyond that, until the tusks of the plunging, leaping peccaries beneath him nearly touched his shoes. Bracing his feet against the rough trunk, he drew the little ax from his belt and prepared to leap as far out toward Jud's tree as possible, although his heart sank and the flesh of his legs and thighs seemed to curl and chill as he looked out upon the gleaming ring of sharp, slashing tusks among which he must leap. Once downed by the herd, and he would be ripped to pieces before he could regain his feet. Jud by this time was on the ground and was just about to shoot, in an attempt to open a passage through the packed herd, when from above came unexpected help.

Out of the dark depths of a near-by silk-

cotton tree sprang with silent swiftness a great black figure which gleamed in the half-light like watered silk.

"Look out! look out! The black tiger!" shouted Pinto, despairingly, from his tree,

the death which haunts every peccary herd. At the squeal, the wild swine swung away from the tree with an instantaneous rush. A jaguar is to a peccary herd what the gray wolf is to the musk-ox herd of the North—the very life of each member of the herd depends upon facing their foe. Upon the instant, every peccary left the trees and hurried toward their dying comrade.

Unfortunately for the jaguar, the force of his spring, added to the impetus of his stroke, carried him too far, and for a moment he whirled over in a half-somersault and was entangled among the vines. Those lost seconds were fatal, in spite of all his strength and swiftness. Even as he recovered his feet in a lithe whirl and flirted over one shoulder the body of the dead peccary as a man might toss a rabbit, the death-ring formed around him. Two deep, the maddened swine circled him. With a deep, coughing roar the tiger dropped his prey and struck with his armed paws lightning-like blows that ripped the life out wherever they landed. By this time, however, the peccaries were beyond all fear of death, and a score of them dashed in upon him. Jud had



"OUT OF A SILK-COTTON TREE SPRANG WITH SILENT SWIFTNES A GREAT BLACK FIGURE"

having shot his last arrow into the frothing circle. Even as he spoke, the "tiger," as the Indians call the jaguar, landed full on the back and shoulders of the hindmost of the desperate, raging circle. As he landed, the great cat struck one blow with that terrible full stroke of a jaguar, which has been known to break the neck of an ox, and the peccary, with a shrill squeal of terror, went down before

involuntarily leveled his automatic at the great brute as it struck the ground, but lowered it with a grim laugh.

"He 's fightin' for our lives as well as his own," he called quietly to Will, as the latter reached the ground and slipped unnoticed past the heaving, tossing, fighting circle of peccaries. In another minute the boy had gained the safety of Jud's tree



and gripped the old man's hand between his own.

"Let 's stay here," said the old trapper, "an' see it out. We can climb this tree if they come back, an' you 'll never see a fight like this again."

Even as he spoke, the circle bent in upon the great cat. With desperate leaps, he tried to spring over its circumference; but each time it widened out so that always in front and at his back and on both flanks was a fence of sharp, slashing tusks. All around him lay dead peccaries which had fallen before his incredibly rapid strokes; but now his dark, gleaming skin was furrowed and slit with long bloody slashes where the tusks of dead and dying boars had gone home. His strength ebbed with his blood. Once more, with a deep, despairing roar, he struck with both paws, killing a peccary at each blow. Then he staggered forward and in a minute was down!

Time and again his great jaws opened and closed, sinking his fierce white fangs deep through the skull or spine of some peccary, but at last only a black heaving of the furious wild-pigs could be seen. At times the dark, desperate head of the dying tiger thrust its way out, only to fall back, smothered and slashed. Amid a scene of brute rage and fury which even Jud, old hunter as he was, had never imagined before, the little party slipped shudderingly away and hastened back over the trail along which they had come, nor ever stopped until they had reached the refuge of the montaria. There they found the rest of the party peacefully sleeping through the midday hours under a cool canopy of broad green palm-leaves which Hen had thrown together. Professor Ditson was more interested in their description of the black tiger than in any of the other details of their adventure.

"It was the melanic type of the jaguar and very rare," he said regretfully. "It was certainly unfortunate that you could n't have collected this one, for there is no specimen living or dead in any of the zoölogical gardens or natural-history museums of the world."

"You see, Professor," explained Jud, "we were kind o' busy in keepin' some seventy-five peccaries from collectin' us. What does 'melanic' mean in American?"

"Any animal may develop either a black or a white type," explained the professor. "When black, it is called 'melanic'; when white, 'albino.' You probably have seen

black squirrels, muskrats, or skunks. They are simply color-variations of the ordinary species. So this 'black tiger' was only a jaguar which for some unknown reason happened to have a black skin. These black examples," he continued, "are neither fiercer nor larger than the ordinary kind, although generally considered so by unscientific observers."

"What about some of those peccaries?" remarked Joe, practically. "Can't we bring in one or two that Pinto killed for fresh meat?"

"No, sir!" returned Jud, emphatically, "I would n't go back into that black bit of woods for all the fresh peccary pork in South America."

It was Hen Pine who noted that Will had taken no part in the discussion and that he was flushed and feverish and suffering intensely from the intolerable pain of the fire-ant bites.

"Honey, you come along with ol' Hen," he said soothingly, "an' he 'll fix you up so that you won't feel that fire-poison hurtin' any more."

Followed by Will, he led the way along the river-bank until they came to a small, round-topped tree with intensely green leaves. With his machete, Hen cut off several of the smaller branches. From the severed ends, a thick, brilliant red sap oozed.

"It 's the dragon's-blood tree," explained Hen, "an' its juice makes the best balm in the world for burns or stings."

As he spoke he rubbed the thick, gummy liquid gently on the swollen and inflamed welts which the venomous bites of the fire-ants had raised on Will's shoulders and back. Almost instantly the throbbing, rankling pain stopped, and there came such a feeling of grateful coolness that Will told Hen it was almost worth the pain of the bite to feel the relief of the cure.

On the way back, Hen discovered another tree which brought the rest of the party nearly as much pleasure as the dragon's-blood had given to Will. It had long, glossy leaves, a straight smooth trunk as large around as a man's body, though it was only about twenty feet high. It was loaded down with what looked like huge plums nearly the size of muskmelons. Hen told Will that it was the wild papaw tree. The fruit was delicious. When they brought back samples to the rest of the party, there was a stampede to the place and the boat was soon loaded with the luscious fruit.

As they explored the bank further, Jud

noticed that Hen was constantly chewing the dark green leaves of the wild cinnamon, which grew abundantly and had a spicy, pleasant smell like the well-known bark of that name. Without saying anything to Hen, the old man picked several and sampled them. Unfortunately for him, it takes prolonged practice to be able to chew wild cinnamon with any degree of comfort. As the fragrant fiery juice touched Jud's tongue and gums he gasped, the tears ran from his eyes as if he had swallowed red pepper, and he spat out the burning leaves emphatically.

"You must have a leather-lined mouth," he remarked to the grinning negro.

A little later, Hen added insult to the injury of the old trapper. They had come to a small tree loaded down with little round, rosy, waxy fruit.

"That what you need, Mars Jud," Hen assured him.

Thinking that it was perhaps a smaller edition of the papaw tree, Jud trustingly sank his teeth into one of the little spheres, only to find it bitter as gall.

"What do you mean by tellin' me I need anything that tastes like that," he howled.

"I did n't say for you to *eat* it," laughed the black giant. "I say you needed it. That tree the soap-tree," and Hen pointed to Jud's grimy hands suggestively.

"I guess we all need it," interrupted Will, tactfully, before Jud could express his indignation further.

Picking handfuls of the little fruit, each one of the party dipped their hands into a pool near the river-bank. The waxy surface of the rosy balls dissolved in a froth of lather which left their hands as clean and white as the best brand of soap could have done.

As the day waned and the coolness of the late afternoon stole through the heat, the montaria was again loosed from the bank. All that night, under the light of another glorious full moon, they traveled fast and far. At last, just as the sun rose, there sounded a distant boom. It became louder and louder until the air quivered and the dark surface of the river showed here and there flecks and blobs of foam. Then, as they swept around a bend in the black stream, there appeared before them a sight of unearthly beauty not seen of white men for twice two hundred years.

(To be continued)

## WIND CHANTEY

By HELEN COALE CREW

NIMBLE-FOOTED young winds, clean young wild winds,  
 Leap and slip and tumble through the meadow grass;  
 And all the sturdy green blades—plume and shaft and shadow—  
 Bow before the young winds, the wild winds, that pass.

Heavy-footed noon winds, hot winds, sleepy winds,  
 Now a gust, now a rest, now a heavy sigh,  
 Sway the crimson poppy-cups and spill a scent of summer,  
 And wilt the stately lilies, as they shuffle by.

Shy winds, high winds, riding on the tree-tops,  
 Brush away the twilight before the moon's face.  
 Gossamer their wings are; they walk in silver moccasins;  
 Leaving not a footprint, invisible they race.

But oh, for a moment at sunrise, at sunrise,  
 The mischief-winds, the whisper-winds, the little winds of play!  
 The little winds of naughtiness, that rumple up a rose-leaf  
 And blink the blue eye of the pool and laugh and slip away!



# A FLAME THAT WILL BURN UNDER WATER

*With It the Diver Can Now Cut Metals*

By ROBERT G. SKERRETT

HAVE you ever seen a bare flame burn under water? You probably have not, for experience has taught you that water will put out fire. Just the same, two young Americans have devised an under-water torch for cutting metal which would seem, offhand, to defy familiar natural laws. What they have done is just one more example of things made possible through perseverance and a measure of ingenuity.

It was only a few years ago that the man of the laboratory gave us what is known as the oxy-acetylene torch—a tool which produces a very intense heat and thus enables a workman to melt and to cut through metallic bodies of one kind or another. To-day, the oxy-acetylene torch is employed both to cut and to unite masses of metal; and the apparatus is now a helpful commonplace in many departments of industry. Men that have to do with the salvaging of wrecked or sunken ships have often wished that they might have at their disposal a similar tool which the diver could use when toiling in the deep; but little success rewarded the efforts made to satisfy this desire until J. W. Kirk and Ralph E. Chapman tackled the problem in 1918.

The Germans were the first to try to make an oxy-acetylene torch which would burn and cut under water. To this end, they put the gas-jet in a cup-shaped nozzle, a sort of miniature diving-bell, and when the mouth of this cap was held downward and the hot gases filled the nozzle, these gases were strong enough to hold the water out and away from the flame. Then the protected flame could melt or cut steel and iron when brought close to these submerged metals. That tool was of little real value, because it had to be lighted above water, to be handled very carefully to keep it burning, and it would not work if taken more than twenty or twenty-five feet below the surface.

In April of 1918, the trans-Atlantic liner *St. Paul*, which was about to be used as a transport, sank just after reaching her pier on the North River water-front of New York City. Young Chapman and Kirk were among the wrecking staff later engaged in raising that steamship. To lighten the vessel, it was necessary to pump thousands of

tons of water out of her flooded interior; and to do this, suction hose was lowered at different points into the ship. These points were few compared with the many compartments that had to be emptied, and so holes were made in the steel walls or bulkheads to let the water flow from the compartments to the mouths of the hose.

At first, the salvors blasted openings in the steel partitions; but the dynamite did a lot of needless damage, which added to the cost of repairing the *St. Paul* afterward. Then it was that Kirk and Chapman recalled that the Germans had tried to make the oxy-acetylene torch fit for under-water cutting, and they set about improving upon the foreign apparatus. They wanted a tool that did not have to be lighted above water, and one that would operate satisfactorily quite fifty feet below the surface of the tide. They desired something that had never been produced before, and to realize this they called electricity to their assistance.

If you break a wire through which current is flowing and bring the two ends close to each other, the electricity will jump across the little gap and create a spark at the same time. This sparking is an electric arc, and we see it applied on a larger scale in the big lamps which light city streets. The temperature of such an arc is very high—about 6000 degrees Fahrenheit, and capable of melting many commonly used metals. It was the electric arc that these young men decided to utilize as the principal feature of their submarine cutting-torch, so that they would have plenty of heat to burn holes through steel bulkheads deep inside of the sunken ship.

But the electric arc will not flame ordinarily if surrounded by water, and some way had to be found to produce a hole in the water, so to speak, in which the arc could work. Chapman and Kirk did this by means of oxy-acetylene gas. Enough of this gas, at a strong pressure, was blown continually out from the tip of the torch, and this steady stream formed a sort of bubble or cavity about the arc and thus kept the water away. By the aid of this tool, twelve passages, about fourteen inches in diameter, were cut inside the *St. Paul* while she rested on the

river-bed, and the deepest of them lay half a hundred feet down. That performance was a fine one; and while the torch did not always operate perfectly, still it proved that its inventors were on the right path.

Before we tell how the tool has been used since the refloating of the *St. Paul*, and how it has been improved so that it will meet harder or more difficult conditions, it might be well for us to get a better idea of the man-

flaming gas, besides protecting the arc, also helps in the cutting.

Since 1918, the torch has been improved considerably, and in its latest form it has been made capable of cutting right through heavy cast-iron. Cast-iron, by the way, is much harder to melt than rolled steel or wrought-iron. The tool, to-day, is an astonishingly simple affair and easy for a diver to handle under water. The business end



J. W. KIRK AND RALPH E. COLEMAN, INVENTORS OF THE "FLAME THAT WILL BURN UNDER WATER." PHOTOGRAPH TAKEN IN THE "ST. PAUL." THE ARROW POINTS TO THE HOLE MADE BY THE UNDER-WATER TORCH

ner in which the electric arc is controlled by the diver. When he goes down to his job, he carries the torch with him, but for the time being it is useless or "dead." The moment he reaches the place where he is to work, he notifies his attendant at the surface by signal-line or telephone to switch on the current and to turn on the gas. Then, when the diver brings the tip of his torch within a quarter of an inch of the metal to be cut, the current leaps across this space and, in doing so, makes the arc which softens or melts the metal. In this case the tip of the torch represents one end, and the submerged metal body the other end of the wire we mentioned earlier in this article when explaining the nature of the electric arc. To put the torch out, the diver has only to move the tool farther from the neighboring metal. The

of it is really nothing more than a rod of carbon, less than an inch thick, and much like the carbons for arc-lights. Two little tubes run lengthwise through the torch carbon, and it is by way of these that the gas is fed to the tip of the torch. Right here it should be said that the gas now used is not acetylene, but another gas which will burn uniformly at any depth within the working limits of a diver. The carbon is set in a suitable holder, and the latter is attached to the hose which conveys the gas from the surface craft and also envelops the wire that carries the current from the dynamo down to the carbon.

Now that we know how the torch is built and the manner in which it works, let us describe some of the things done with it in the past three years. In February, 1919, the big freighter *Lord Dufferin*, while lying



at anchor in New York Harbor, was struck by the transatlantic steamship *Aquitania*, and the liner completely cut off sixty odd feet of the stern of the cargo craft. The rest of the *Lord Dufferin* was promptly towed into shallow water and beached on the nearby flats before her salvage was undertaken. When divers examined the damaged ship, it was found that part of her torn plating reached downward fourteen feet into the underlying mud, and this had to be detached before the boat could be taken to a dry-dock for repairs. The submarine torch cut this steelwork free so that the eight-ton mass could be got out of the way.

Last December, the U. S. Submarine S-48 sank in Long Island Sound while on a trial trip; and after the men imprisoned within her managed, by heroic efforts and resourcefulness, to get her bow above water so that all hands could be saved, salvors were called upon to refloat the vessel. To do this, it was necessary for them to pump out the large after-compartment occupied by the

only way to lift the hatch cover was to cut a hole through the center of this heavy cast-steel door, so that the locking device could be released. Armed with his torch, a diver went down seventy feet and succeeded in cutting the hole which is shown in the picture below. Afterward, divers entered the boat and closed the doors at the forward and after ends of the motor-room. Next, they sealed the open hatch with a temporary cover through which a hose passed to a powerful wrecking-pump. With these arrangements completed, it was a comparatively easy matter to pump out the water and raise the boat.

But the biggest thing so far done by the help of the Chapman-Kirk torch was that of hastening the repair of a broken water-supply pipe in the bed of New York Harbor. Staten Island (which forms the Borough of Richmond of the City of Greater New York) gets its drinking-water from the Catskill Mountains through a three-foot cast-iron main, 10,000 feet long, which is linked with

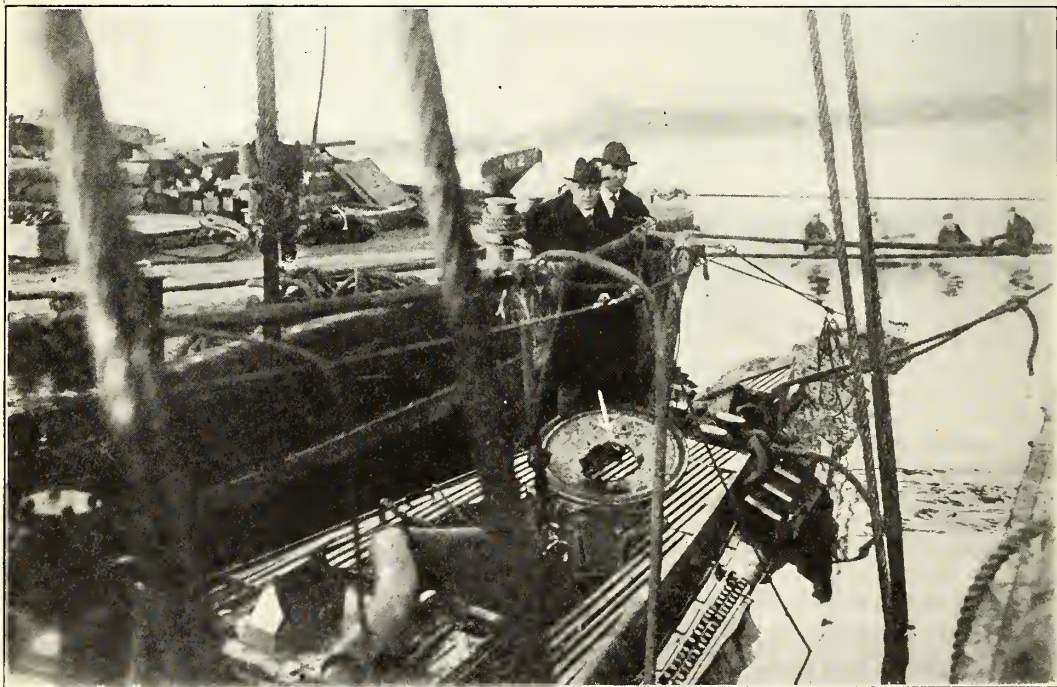

THE S-48 AFTER BEING REFLOATED. THE WHITE ARROW INDICATES THE HOLE CUT IN THE HATCH COVER

electric motors. The usual entrance to that motor-room from the deck was through a hatch, but the cover to this passage had been locked tight from the inside before the submarine started on her under-water run. The

the Brooklyn portion of the system. Fully 125,000 people are dependent upon the water which so reaches Staten Island. On February 2 of the present year, a dredge, working near the Staten Island shore, accidentally

smashed one of the twelve-foot lengths of this main. The water had to be shut off at once and steps taken to make the pipe fit for service again with the least possible delay.

To understand the nature of the task, we

Therefore, the salvors placed a testing tank upon the biggest of their floating derricks, and in this they tried out the torches until they were just right and, at the same time, trained a crew of six divers to use them. In



ONE OF THE DIVERS WITH THE CUTTING TORCH IN HIS HAND, SHOWING HOW IT WAS USED UNDER WATER

must bear in mind that the main, where injured, was fifty-three feet below the surface of the harbor and directly under twenty-odd feet of rather soft mud. This mud had to be cleared away over a wide area so that there would be no danger of it sliding in on the divers when they were at work. The next thing was to remove the broken pipe without disturbing or displacing the neighboring lengths, for any jarring movement might cause their joints to leak and thus impair this conduit, vital to the health and the welfare of a large number of people. Because of the need for haste, the engineers that were to do the work decided to use submarine torches to cut free the injured piping.

Before starting the cutting, however, some experiments had to be made to fit the torches for the job. Until then, cast steel was the hardest metal dealt with, while the main is of cast-iron, which calls for a temperature hundreds of degrees higher to melt it.

this manner, Mr. Chapman and his associate electrical engineer got everything in readiness and selected the gas best suited to assist the electric arc.

When the men began their operations below the surface, the temperature of the water was nearly at the freezing point; and the water was so full of floating mud that it was almost pitch black. They could find their way from point to point only by groping like the blindfolded. These facts give us an idea of the difficulties with which the divers had to cope. However, the men guided themselves by their sense of touch; and they found that the damaged pipe had a long, gaping break on the upturned side. Part of their work required that this break be made still bigger at one point, and torches were used to do this cutting.

After the hole had been enlarged, the divers took turns in crawling into the main to get out the mud for thirty or forty feet beyond



each end of the injured length of pipe. This was to make it safe for the men to lie in the pipe when doing some of the cutting, later on. They would have been in a bad fix had the

finished. It took them just about nine days to do this. At times, a diver would be able to cut four inches of the pipe in the course of an hour, and then, again, when conditions were more favorable, he would be able to make a cut six inches long in the same period. All told, the cuts measured nearly thirty feet, if taken in a straight line; and nothing like this has ever been accomplished before under water.

When the torches had performed their part, it was an easy matter to hoist the detached pipe to the deck of the floating derrick and then to lower a new length of pipe and fasten it into place. In less than thirty days the main was repaired, thoroughly washed out, and all germs killed by a powerful fluid chemical. Then the water was turned into the pipes on Staten Island, and the fear of a scarcity was ended. The health authorities and the dependent people were worried for a while, but the submarine metal-cutting torches, by speeding up the work, shortened this interval of anxiety.

The submarine torches have done excellent service in other directions, which we can not



HOISTING THE DAMAGED WATER-PIPE ABOARD THE FLOATING DERRICK

mud shifted and buried them. The rest of the task of getting the pipe ready to lift it to the surface consisted in cutting off the top half of the pipe at one joint and severing it all around at the other joint. The pipe was one and five-eighths inches thick where most of the cutting was done, but the torches were also obliged to melt through metal considerably thicker—some of it being three and a half inches thick. The job was a tedious one; and night and day the divers worked, one after another, until all of the cutting was

mention here because our space is limited, but enough has been said to show just how useful they are in meeting puzzling situations where metallic bodies have to be dealt with at different depths under water.

Messrs. Kirk and Chapman have set a splendid example to other ingenious American youths; and if you also have an idea which you think worth developing, and likewise patenting, don't be dismayed by temporary set-backs, but stick to it, and you, too, may reach your goal.

## BETWEEN TWO DEATHS

*An account of a crew's heroism against great odds under water*

By M. V. SIMKO

"CAPTAIN AUSTIN and Commander Haas were at the control-board when we made our 'crash dive.' We had no sooner gone under the surface, than we all knew something had gone wrong. There were cries from the men aft, and they came tumbling into the control-room from the engine-room.

"Water was flooding the engine-room, and the last man had to swim in water up to his waist to reach the control-room. The door to the engine-room was then slammed shut and bolted."

This reads like a page from some fast-moving tale of the sea, yet it is the narration of an actual occurrence. Peter Dunne, aged twenty-two, one of the heroes of the ill-fated submarine S-48, related the above incident to a reporter of the "Bridgeport Post."

"Pete" Dunne, of Bridgeport, Connecticut, is to-day acclaimed a hero by his native city for his act of daring valor; but the entire crew must be given its just due for the heroic stamina possessed by each man, when one considers the gallant sacrifices that were so readily made.

One morning last December, the submarine S-48, equipped with a crew of forty-one men, left the Bridgeport harbor on a trial trip. The submersible was making favorable progress in about seventy-five feet of water. The city was some seven miles astern when the order was given to submerge.

The craft responded with such suddenness, and the roar of the inrushing water was so pronounced, that Captain Austin at once suspected that something was wrong. The cries of some of the men confirmed his suspicion. Water was rushing into the engine-room—roaring in, tumbling in—tons of it!

Due to some one's neglect at the shipyard, an uncovered manhole was responsible for what had occurred. The life of every man was now in peril. Forty-one men faced death, a horrible death! So far, they were safe in the control-room. For how long?

The ship, now overburdened with the flooding water, refused to rise. Slowly it sank deeper and deeper, until the stern at length settled into the mud of Long Island Sound.

The possibility of lifting the prow above the surface of the water suggested itself. To this purpose, every man contributed valiant efforts. The heavy anchors were cut loose. The oil-tanks were blown. The dummy torpedoes were discharged through the forward tubes. Through the sounding-machine were dropped, one after another, 90-pound pig-leads—five tons of them! This weight comprised the ballast in the bow.

Relieved of all this excess burden, the prow began to lift, when another terror confronted the unfortunate crew—the deadly fumes of chlorine gas began to irritate their throats.

Some one cried out, "Gas"!

To every man was brought the realization that another enemy sought to overcome them. The salt water in which they were submerged had entered the battery-room, and, meeting with the sulphuric acid of the batteries, produced the poisonous gas with which every veteran of the World War is well acquainted.

Forty-one men, trapped like rats in a cage, faced this new foe with grim resolve to conquer it. In frantic desperation, they fell to bailing out the water—bailed it out with buckets, pails, tiny cups, and even with their cupped hands! It was a big endeavor against great odds; and it was a vain endeavor. Faster than they could bail it out, the water, like an eager enemy, seeped into the battery compartment, flowed in, rose deeper and deeper.

The deadly gas fumes became more offensive, more unbearable. Heads started to ache, throats became hoarse and sore, lungs seemed incapable of taking their allotment of air, breathing was becoming difficult. The crew began to believe that it was only a matter of time before the fumes would do their deadly work.

Even in an extremity such as this, one should never despair. Electrician Fritz believed this. He seized a coil of rubber hose that DeLorme, impelled by some hunch, had picked up earlier in the day in the shipyard and brought along with him.

Fritz cut this hose into suitable lengths, and distributed a portion to several men. Each man set one end into the water in the



battery-room, the other end was taken into the mouth. Here were men truly to be called heroes. Every man well knew the dangers of chlorine gas! Every man well knew that, once it touched the mouth, it would burn like so much fire! Every man knew that he must draw and draw until the fluid came and finally touched the tender tissues of cheek and mouth! Yet not one flinched. Not one shirked. Not one passed his tube to another.

They sucked and drew on their tubes until the burning liquid scalded their mouths; they drew until a steady stream was coming from each tube—until relief was assured. The poisonous chemical was in this manner siphoned from the battery compartment and discharged into the bilge.

Mouths burning from the violent acid, throats hoarse and painful, the heroes waited. They waited and prayed. They waited and had the satisfaction of finding that the oppressive fumes began to diminish. At least, they were spared a death from chlorine gas!

Another thrill of hope came to them when

His superior officers at first hesitated; but when they were assured that the outer door of the tube was above the water, they consented to the venture.

Through a greased tube, twenty-one inches in diameter and twenty feet long, Dunne crawled upward. It was no simple task. After he crawled through the full length, having achieved the outer door, he realized that his self-imposed task was one to try his valor. To climb up the side of the slippery submarine was impossible; to dive into the cold water was far from tempting. The dangling anchor-chain a few feet aft offered him a way. He poised himself and threw himself forward, arms outstretched—a gallant effort, but unsuccessful.

The young man fell short of the chain. He splashed into the icy water of a December night. In the darkness, the waves dashed over him, numbing his limbs. Paralyzed with the cold, he finally managed to get hold of a stanchion and so dragged himself to the surface of the submersible.

The roaring waves, beaten high by a fierce wind, still threatened him. As if

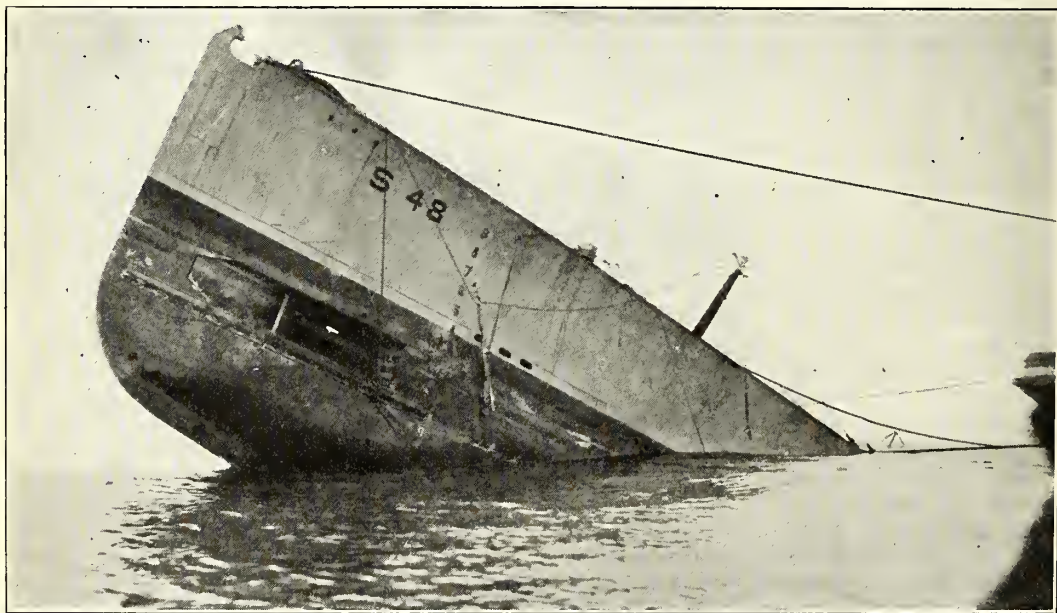

Photograph by Charles G. Doehrer

THE SUBMARINE S-48, SHOWING THE TORPEDO-TUBE THROUGH WHICH DUNNE CRAWLED

it was known that, although the tail-end of the submarine was imbedded in mud, the nose had at length risen above the surface of the water. It was at this stage that Pete Dunne volunteered to make his way out through one of the forward torpedo-tubes.

angered to be cheated of their prey, the billows rushed up at him and tugged at his unsteady legs. Struggling on, the hero soon reached the forward end. He bent down and shouted that the lights of Bridgeport were visible.

On his request a rope was tossed up to him. Snow was falling and a cruel December gale bit him through to the marrow. His wet clothes froze on his back. With a supreme effort, he made fast the end of the

ill-fated submarine. The crew was safely transferred to the tugboat and rushed to a hospital.

The chance picking up of a coil of hose, the daring dive into ice-cold water, the unmis-



Photograph by Charles G. Doehrer

#### SALVAGING THE SUNKEN SUBMARINE

rope and slid down the ship's steel side, down into the tube and into the warmth of the ship.

While Dunne's clothes were changed and warmth applied to his body, other members crawled to the top deck, using the fastened rope. Mattresses and even wearing apparel, soaked in oil, were set on fire atop the submersible, but the flames at first failed to attract any passing ship. The electrician wired an apparatus, and S. O. S. signals were sent.

Hungry, fatigued, dispirited, the crew sang out with joy when, a little after ten o'clock at night, a tugboat, attracted by the flaming torches, came to the rescue of the

takable strain of valor possessed by each man, the patience of the crew, the grim determination to combat misfortune and even death—thanks to all this, the S-48 will again be a sea-going craft and not a mass of junk on the bottom of the sound, while forty-one gallant men are still in the land of the living.

To-day, every man is on duty again. To be submerged for almost a full day and threatened with asphyxiation is not an experience many would crave, yet these men came out smiling. For that is the spirit of manhood to-day. Keep smiling and never give up!

### MR. JAY

TRIM, with not a tear or tatter  
On your coat of blue and gray,  
Drinking in the morning attar,  
Perched upon a linden spray,  
How you chatter—chatter—chatter!  
What 's the matter, Mr. Jay?

Thrush and wren and robin scatter  
Scraps of song along the way,  
If the raindrops pad and patter,  
Or the sun makes bright the day;  
But *you* only chatter—chatter—  
What 's the matter, Mr. Jay?

*Clinton Scollard.*



# THE TURNER TWINS

By RALPH HENRY BARBOUR

## SYNOPSIS OF PREVIOUS INSTALMENTS

AT Hillman's School the problem of securing money for the expenses of the football team is solved by Ned Turner, who proposes an outdoor fête. Mr. Starling, whose son Bob is a day pupil at the school, offers his premises, and the affair is a big success. Ned and Laurie Turner are twins and there semblance between them is so close that it is nearly impossible to tell them apart. To this fact is due the success of the principal feature of the entertainment, when Laurie, securely tied to a chair, is magically whisked from sight and an instant later appears, apparently, at the back of the audience. Polly Deane, whose mother owns the little tuck-shop near the school, and her chum, Mae Ferrand, lend their assistance to the boys.

## CHAPTER XV

### SOLD OUT!

A MOMENT of surprised silence gave place to hearty applause. Theoretically it might have been possible for the boy in the chair to vanish from behind the screen, reach the farther end of the garden, and run back into sight; but actually, as the audience realized on second thought, it could n't possibly have been done in the few seconds, surely not more than ten, that had elapsed between the placing of the screen and the appearance of the boy behind them. And then, how had he got himself free from the ropes? An audience likes to be puzzled, and this one surely was. The garden hummed with conjecture and discussion.

Meanwhile, on the platform the Signor was modestly bowing alternately to the audience and to his subject, the latter apparently no worse for his magic transposition. And the orchestra again broke into its interrupted melody. The applause became insistent, but Signor Duodelli, perhaps because his contract with the committee called for no further evidence of his powers, only bowed and at last withdrew. Whereupon the Banjo and Mandolin Club moved into the house, and presently the strains of a one-step summoned the dancers to the big drawing-room.

Laurie, unconsciously rubbing a wrist, smiled as he listened to the comments of the dissolving audience. "Well, but there's no getting around the fact that it was the same boy," declared a pompous little gentleman to his companion. "Same hair and eyes and everything! Could n't be two boys so much alike, eh? Not possibly! Very clever!"

Laurie chuckled as he made his way to Polly's booth. That young lady looked a little tired, and, by the same token, so did the Yale booth! Only a bare dozen framed pictures and a small number of post-cards

remained of her stock. "Don't you think I've done awfully well?" asked Polly, a trifle pathetically. She seemed to need praise, and Laurie supplied it.

"Corking, Polly!" he assured her. "I guess you've sold more than any of the others, have n't you?"

"N-no, I guess some of the others have done better, Nod; but I think they had more attractive articles, don't you? Anyhow, I've taken in twelve dollars and thirty cents since supper, and I made four dollars and eighty-five cents this afternoon; only I must have dropped a dime somewhere, for I'm ten cents short. Or perhaps some one did n't give me the right amount."

"Why, that's seventeen dollars!" exclaimed Laurie. "I did n't think you had anywhere near seventeen dollars' worth of things here, Polly!"

"Oh, I did n't! Not nearly! Why, if I'd sold things at the prices marked on them, Nod, I would n't have had more than half as much! But lots of folks *wanted* to pay more, and I let them. Mr. Conklin, the jeweler, bought a picture, one of the funny landscapes with the frames that did n't fit at the corners, and he said it was ridiculous to sell it for a quarter, and he gave me a dollar for it. Then he held the picture up and just laughed and laughed at it! I guess he just wanted to spend his money, don't you? You know, Ned said we were to get as much as we could for things, so I usually added ten cents to the price that was marked on them—sometimes more, if a person looked extravagant. One lady came back and said she'd paid twenty-five cents for a picture and it was marked fifteen on the back. I said I was sorry she was dissatisfied and I'd be very glad to buy it back from her for twenty."

Laurie laughed. "What did she say to that?" he asked.

"She said if I wanted it bad enough to pay

twenty cents for it, she guessed it was worth twenty-five, and went off and did n't come back." Polly laughed and then sighed. "I'm awfully tired. Does n't that music sound lovely? Do you dance?"

Laurie shook his head. "No; but, say, if you want to go in there, I'll watch the booth for you."

Polly hesitated. "It's funny you don't," she said. "Don't you like it?"

It was Laurie's turn to hesitate. "No, not much. I never have danced. It—it seems sort of silly." He looked at Polly doubtfully. Although he would n't have acknowledged it, he was more than half sorry that dancing was not included among his accomplishments.

"It is n't silly at all," asserted Polly, almost indignantly. "You ought to learn. Mae could teach you to one-step in no time at all!"

"I guess that's about the way I'd do it," answered Laurie, sadly—"in no time at all! Don't you—could n't you teach a fellow?"

"I don't believe so. I never tried to teach any one. Besides, Mae dances lots better than I do. She put the things she had left on Grace Boswell's booth and went inside the minute the music started. She wanted me to come, but I thought I should n't," added Polly, virtuously.

"You go ahead now," urged Laurie. "I'll stay here till you come back. It is n't fair for you girls to miss the dancing. Besides, I guess there won't be much more sold now. Folks have begun to go, some of them, and most of the others are inside."

Polly looked toward the house. Through the big wide-open windows the lilting music of a waltz floated out. The Banjo and Mandolin Club was really doing very well tonight. Polly sighed once and looked wistful. Then she shook her head. "Thanks, Nod," she said, "but I guess I'll stay here. Some one *might* come."

"What do you care? You don't own 'em! Anyway, I guess I could sell a post-card if I had to!"

"You'd have trouble selling any of those pictures," laughed Polly. "Are n't they dreadful? Where did they come from?"

"Pretty fierce," Laurie agreed. "They came from the Metropolitan Furniture Store. The man dug them out of a corner in the cellar. I guess he'd had them for years! Anyway, there was enough dust on them to choke you. He seemed awfully tickled when we agreed to take them and let him alone!"

"I should think he might have! We girls

agreed to buy things from each other, just to help, but the only things they bought from me were post-cards!" Polly laughed as though at some thought; and Laurie, who had elevated himself to an empty corner of the booth and was swinging his feet against the blue draping in front, looked inquiringly. "I was just thinking about the boys," explained Polly.

"What about them? What boys do you mean?" Laurie asked coldly.

"The high-school boys. They're awfully peeved because we girls took part in this, and not one of them has been here, I guess."

"Cheeky beggars!" grumbled Laurie. "Guess we can do without them, though. Here comes Bob's father."

Mr. Starling was bent on a most peculiar mission. Laurie and Polly watched him stop at the next booth and engage in conversation. Then a fat pocketbook was produced, a bill was tendered, and Mr. Starling strolled on. At the Yale booth he stopped again.

"Well, Turner," he greeted, "this affair looks like a huge success, does n't it? Why are n't you young folks inside there, dancing?"

"I don't dance, sir," answered Laurie, somewhat to his chagrin, in a most apologetic tone. "And Polly thinks she ought to stand by the ship. This is Polly Deane, Mr. Starling."

Bob's father shook hands cordially across the depleted counter, and assured its proprietor that he was very glad indeed to make her acquaintance. Then he added: "But you don't seem to have much left, Miss Polly. Now, I'm a great hand at a bargain. I dare say that if you made me a fair price for what there is here, I'd jump at it. What do you say?"

Polly apparently did n't know just what to say for a minute, and her gaze sought counsel of Laurie.

"If you ask me," laughed the latter, "I'd say fifty cents was a big price for the lot!"

"You're not in charge," said Mr. Starling, almost severely. "I'm sure the young lady has better business ability. Suppose you name a price, Miss Polly."

"We-ell—" Polly did some mental arithmetic, and then, doubtfully, "A dollar and a half, sir," she said.

"Done!" replied Mr. Starling. He drew forth a two-dollar bill. "There you are! Just leave the things where they are. I'll look after them later. Now you youngsters go in and dance. What's this? Change?



My dear young lady, don't you know that change is never given at an affair of this kind? I really could n't think of taking it. It—it's a criminal offense!" And Mr. Starling nodded and walked away.

"By Jove, he's a brick!" exclaimed Laurie, warmly. "Look, he's doing the same thing everywhere!"

"I know," answered Polly, watching. "It's just dear of him, is n't it? But, Nod, what do you suppose he will do with these awful pictures?"

"The same thing he will do with that truck he's buying now," was the laughing reply. "He will probably put them in the furnace!"

"Well," said Polly, after a moment, "I suppose we might as well go inside, don't you? We can look on, anyway, and—" with a stifled sigh—"I'd 'most as lief look on as dance."

Laurie followed, for the second time in his life wishing that the Terpsichorean art had been included in his education!

## CHAPTER XVI

### NED HAS AN IDEA

"THREE hundred and thirty-three dollars and eighty-five cents," said Ned, in very satisfied tones. "We took in three hundred and sixty-three five, but we had twenty-nine twenty to come out for expenses. Not so bad, what?"

"But something tells me," answered Laurie, mournfully, "that if all our expenses were deducted, we'd have less than that. You see," he explained to Polly, "I lost the piece of paper that I set down the money I paid out on, and I just had to guess what it all came to, because I'd never had time to add it up."

"I dare say you guessed enough," replied Ned, untroubled.

"I dare say I did n't, then!" was the indignant response. "If I did, where's all the money I had when I started? I've got a dollar and ninety cents left, and I had over four dollars when you roped me in on the thing! I'm more than two dollars shy, I tell you!"

"Oh well, it's gone for a worthy cause," laughed Ned.

"Maybe," Laurie grumbled, "but I notice that none of yours has gone that way. You always made me pay for everything!"

"Well, I think you did beautifully," said Polly. "I never suspected you'd make so much!"

They were in the little garden behind the

shop. It was the second day after the fête, and the bell in the Congregational church tower had just struck two. There was a perceptible nip in the air to-day, and the flowers in the border showed blackened leaves, while the nasturtiums were frankly limp and lifeless. But here in the sunshine it was warm enough, and Laurie, spurning the bench, was seated tailor fashion on the yellowing turf. Polly had stated her absolute certitude that he would catch cold, but Laurie derided the idea.

"We're awfully much obliged to you girls," said Ned. "We would n't have done nearly so well if you had n't helped. I think the committee ought to give you a—a vote of thanks or something."

"Oh, we all loved it!" Polly assured him earnestly. "We had heaps of fun. Why, I would n't have missed that disappearing trick for anything. I was positively thrilled when Laurie came running up the garden!"

The boys' laughter interrupted, and Polly looked puzzled.

"That was n't Laurie," explained Ned. "That was me."

"But I was sure you were the one in the chair! And if you were in the chair, how could you—"

"I was n't, though. That was Laurie."

Polly sighed despairingly. "I'll never get so I can tell you apart," she said; "unless I hear you talk, that is! I don't see yet how it was done. Won't you please tell me?"

"It was as easy as easy," replied Ned. "You see, the way I planned it first—"

"The way *who* planned it?" inquired Laurie.

"Well, the way *we* planned it, then."

"Hold on! Whose idea was it in the first place, partner?"

"Oh, don't be so fussy! Anyway, you could n't have done it without me!"

"I never said I could. But you've got a lot of cheek to talk about the way *you*—"

Polly clapped her hands to her ears. "I'm not being told how it was done, and I do want to know. Go on, Nid."

"Well, it was done like this. You see, Laurie was tied to the chair, and I was hiding out at the other end of the garden. Then Lew Cooper put the screen around the chair." Polly nodded. "Then I started toward the platform, and every one turned to look at me." Polly nodded again. "Well, right behind the platform was the bulkhead door into the cellar. When Cooper shouted to me to come on, two fellows who were on the

stairs waiting pushed the door open, grabbed Laurie, chair and all, and whisked him down cellar. Then they put another chair, just like the first one, behind the screen, and when Cooper pulled the screen away, there it was,

Laurie, "if we could have taken the screen away and showed the empty chair before Ned came into sight; but there did n't seem to be any way of doing that. We had to have the people looking the other way, and



"SUPPOSE YOU NAME A PRICE, MISS POLLY"

just as if Laurie had somehow untied himself and—and vanished! Of course, if any one had been looking at the screen instead of at me just then, he might have seen what was going on, although it was pretty dark behind there and he might n't have. Anyway, no one was, I guess. The trick depended on the—the faint similarity between us. Lots of fellows who knew us were on to it, but the folks from the village were certainly puzzled for fair!"

"Indeed they were," agreed Polly; "they just could n't understand it at all!"

"It would have been better," mused

we had to work quick. As it was, I was half killed, for Wainwright and Plummer were in such a hurry to get the other chair up there that they just dumped me on my back! And then they ran upstairs through the kitchen to see the end of it, and I was kicking around down there for five minutes!"

"Well," said Ned, a few minutes later, "I'm not finding out what to do with this." He opened one hand and exposed some bills and two ten-cent pieces folded into a wad. "Your mother says she won't take it, Polly—that she did n't understand we were going to pay her for the cream-puffs. Gee, we wouldn't have thought of asking her to make them for nothing!"

Polly nodded sympathetically. "Mother says, though, that the boys bring so much trade to her that it's only fair for her to help them."

"That's poppycock!" said Laurie. "Seven dollars and twenty cents is a lot of money. Look here; don't you think she ought to take it, Polly?"

Polly was silent a moment. Then she nodded affirmatively. "Yes, I do," she said frankly. "She really needs the money, Nod. I would n't tell any one else, but we're just frightfully hard up, and I would n't be a bit surprised if Mother had to give up here before very long."

"Give up!" exclaimed Ned. "You mean—go away?"

"Yes. You see, she does n't make very much money in the store; not nearly so much



as she used to before the war sent prices so high. And then, what with taxes and water and light, and the interest on the mortgage, why, it hardly pays. Just the same, if she says she won't take the money, Nid, why, I guess she won't, and that's all there is to it. But she ought to!"

"Can't she charge more for things?" asked Laurie. "Every one else does nowadays. That bake-shop down on Hudson Street gets eight cents for cream-puffs and éclairs, and you sell them for six."

"I know; but Mama says six cents is enough and that the boys ought n't to have to pay any more. And lots of things she sells for hardly any more than she used to before prices advanced. Why, I have to watch all the time, and when bills come in for things, I have to compare them with what we're getting for them, and lots of times I find that Mama's been selling for less than she's paid! She just won't be a profiteer, she says!"

"Gee! I hope you don't have to shut up," said Laurie. He looked around the little garden. "It—it's such a jolly place! And the house and—and everything. Gee, that would be a shame!"

Polly sighed while she nodded. "It is nice," she agreed; "but there are so many things that ought to be done! Uncle Peter never would do much for us. He did promise to have the house painted, but he died about a month after that, and so it was never done."

"Suppose he up and died so 's he would n't have to do it?" inquired Laurie, suspiciously.

Polly shook her head and looked a trifle shocked, until she caught the smile in Ned's eyes.

"It does n't look as if it would cost much money to paint it," remarked Ned, looking up at the rear of the little two-and-a-half-story building. "It's not much more than a doll's house, anyway. How many rooms are there, Polly?"

"Three upstairs, and then a sort of attic room under the roof; and two downstairs."

"Uh-huh. I just wondered. It would n't be much of a trick to paint the outside. Bet you I could do it in a couple of days."

Laurie gasped. "A couple of days! You? How do you get like that? It would take a real painter a week to do it!"

"Maybe; but I'm not a real painter," answered Ned, grinning. He glanced at the crumpled wad in his hand and held it tentatively toward Polly. "Maybe you'd better take charge of this, Polly, until we decide what to do with it."

But Polly put her hands resolutely behind her, and shook her head with decision. "No, Nid, I'd rather not. If Mama says she won't have it, she won't, and you might just as well give it back to the—the fund."

Somewhat to Laurie's surprise, Ned pocketed the money without further protest. "All right," he said. "It's very kind of your mother. We must n't forget to see that her name's included in the list of those who donated things, Laurie. This week's 'Messenger' is going to tell all about it. Well, I've got to pull my freight. You coming, partner?"

"Yes, I guess so," replied Laurie, without much enthusiasm. "I promised Bob and George to get another fellow and play some tennis this afternoon."

"Gee! it must be great to have nothing to do but play," sighed his brother.

"Huh, any one would think, to hear you talk, that you were working," replied Laurie, crushingly. "All you do is stand around and watch the others."

"Think so?" Ned smiled in a superior way. "You come down this afternoon and see how much standing around I do. Joe Stevenson says I've got to practise goals now. Is n't that the limit?"

"I suppose it pains him to see you loafing," said Laurie. "Anyway, I dare say it'll keep you out of mischief."

Laurie led the way to the back fence, against which leaned a plank with two pieces of wood nailed across it. This afforded a short cut to and from school, and was an idea of Bob's. From the top of the fence they dropped into the shrubbery and then made their way to the side gate. The arbor had not yet been denuded of its evergreen clothing, and there were other evidences of the recent festival in the shape of crumpled paper napkins lying on the ground. Thomas had taken down the lanterns and was packing them away in their case by the kitchen porch, and the boys called a greeting to him as they passed.

"Bob still mean to make a tennis-court here?" asked Ned, as they went through the gate.

"Yes. He's going to tear down that arbor right away, he says. So far, though, he has n't found any one to do the work on the court. Every one is busy. I don't believe he will get it done in time to use it this fall."

"Of course he won't. It's nearly November now. Say, you'd better take this money and hand it over to Whipple. You'll see him

before I do. And tell him to put Mrs. Deane's name down with the other folks who contributed, will you?"

"All right; but I think it 's a shame to let her stand for all those cakes."

"So do I; only—"

"Only what?"

"Maybe we can make it up to her another way. I 've got an idea, Laurie."

"I hope it 's better than most of 'em. What is it?"

And when Ned had explained it, Laurie considered a long moment and then indorsed it enthusiastically. "That 's corking!" he cried. "For once, Ned, the old bean has worked! Only, when could we—"

"Christmas vacation," said Ned. "We won't have much to do then. What do you say?"

"I say that, for the first time in my life, Neddie, I 'm proud to acknowledge you as my twin!"

## CHAPTER XVII

### POLLY TELLS A SPOOK STORY

ASSURED of sufficient funds to complete its season without financial embarrassment, the Hillman's football team seemed to take a new and firmer grip on things. Practice went well that week, and the players showed vim and snap. Perhaps the colder weather helped, too. The line-up that faced the scrubs on Friday for a short scrimmage was, barring accidents, that which would, four weeks later, start the game against Hillman's old rival, Farview Academy. Farley and White were at the ends, Captain Stevenson and Pringle were the tackles, Emerson and Corson were the guards, and Kewpie Proud-tree was at center. Frank Brattle at quarter, Mason and Slavin for halves, and Pope at full-back composed the rest of the team. There were some weak places, to be sure; but on the whole, Coach Mulford was fairly satisfied that he had the parts for a capable machine.

Ned was still playing on the scrub eleven, and doing rather well. As a punter, at least, he deserved his position at left half, and it might be that he would develop into a fair goal-kicker; for in the last four days, under the tuition of the coach and Full-back Pope, he had shown excellent promise. Those morning lessons, now abandoned, had grounded Ned well in the art of toeing the pigskin, and whatever fame the future might hold for him as punter or drop-kicker or

place-kicker, much of the credit would be Kewpie's.

To-day, in the second ten minutes of the scrimmaging,—there was but twenty minutes in all,—Thursby, playing quarter, and probably acting under instructions, gave Ned his first chance to show what he could do in the way of field-goals. Unable to reach a point nearer than twenty yards to the school team's goal, Thursby called for "kick formation, Turner back," and Ned went up-field with his heart in his mouth. Although the cross-bar was less than thirty yards from where he took his stand and almost directly in front of him, it looked to Ned to be a woe-ful distance away and the angle much more severe than it was. But he did n't have much time for reflection, for Thursby called his signal quickly and the leather came back to him at a good pass and the school team was crashing through.

Ned always thought that he closed his eyes when he swung his toe against the rebounding ball and trusted to luck, but I doubt it, for the pigskin described a perfect arc and went well and true over the bar; and if Ned had had his eyes closed, I don't believe the pigskin would have acted that way at all. Most of the scrub-team players thumped him on the back and showed their delight in other ways, for they had not scored on the school team for nearly a week; while, at a little distance, Coach Mulford nodded his head almost imperceptibly. It was too bad Ned did n't see that nod, for it would have pleased him far more than the buffets of his team-mates.

The next day Hillman's made a trip to Warring and played the Lansing team to a standstill, returning with a 22-0 victory tucked under its belt. Ned got into the game for a bare five minutes at the last, as did half a dozen other substitutes; but he was not called on to kick any goals, for which he was at once sorry and glad. To have had the eyes of nearly a thousand persons on him would, he thought, have precluded any possibility of success; but, on the other hand, had he succeeded— He sighed for lost opportunities!

The attendance that afternoon was a matter of great joy to Manager Dave Murray, for Hillman's went home with a neat sum as its share of the day's profits, a sum far larger than he had counted on—large enough, in fact, to make up the difference between the net receipts from the fête and the three hundred and fifty dollars aimed at.



Hillman's good fortune held for another week. There were no accidents during practice; every fellow in the line-up played for all that was in him; and the scrubs took a licking every afternoon. Ned twice more gained glory as a drop-kicker, although on a third occasion he failed lamentably. Unfortunately, neither of his successes brought victory to his team, since the opponents had on each occasion a safe lead in the scoring. Every afternoon, following the scrimmage, Ned was presented by the coach with a nice, battle-scarred football, and instructed to go down to the east goal and "put some over." Sometimes Hop Kendrick or Ben Thursby went with him to hold the ball while he tried placement kicks, and always an unhappy substitute was delegated to retrieve the pig-skin for him; but the coach let him pretty much alone, and Pope looked on only occasionally and was surprisingly sparing of comment or advice. And yet Ned improved, rather to his surprise, since he felt himself neglected and, as he said to Laurie, did n't see how they expected a fellow to learn goal-kicking if they did n't show him a little! But, although he did n't realize it, Ned had reached a point in his development where he was best left to his own devices, and Coach Mulford knew it and forbore to risk confusing him with unnecessary instruction. So Ned pegged away doggedly, and got results, as he considered, in spite of the coach!

Against the Queens Preparatory Institute, which journeyed up from the city on Saturday, the Blue was able to emerge from four grueling fifteen-minute periods with the score 6-6, for the Blue's a very satisfactory showing, as Q. P. I. had downed stronger elevens than Hillman's. So November began its second week, and cloudy days and not infrequently rainy ones took the place of the sunny weather of October.

Laurie would have been somewhat at a loss for a way in which to spend his afternoons at that time had it not been for Bob Starling's overmastering desire to build a tennis-court in the garden of the Coventry place. The weather was far too cold for tennis, although now and then he and Bob played George and Lee Murdock, and the wrecking of the old grape-arbor, preparatory to digging up the sod, proved a welcome diversion. Sometimes Thomas took a hand; but Thomas had plenty to do indoors, and the work was accomplished almost wholly by Bob and Laurie, with the occasional moral support of George or Lee.

Usually an hour's labor with hammer or crowbar ended with an adjournment to the Widow Deane's, by way of the back fence, for refreshments. Sometimes it was warm enough to forgather in the little garden behind the shop, and, armed with cream-puffs or tarts, spend a jolly half-hour in the society of Polly and Mae. At such times Mrs. Deane, hearing the shouts and laughter, came to the back door and smiled in sympathy.

One glorious afternoon of mingled sunlight and frost, there was an excursion afoot out into the country in search of nuts. Polly and Mae and Laurie and George and Bob and Lee formed the party. They carried two baskets, one of which George wore on his head most of the way, to the wonderment of the infrequent passers. Mae knew, or thought she knew, where there were chestnut-trees, and led the way for three miles to what is called Two Jug Ridge. The chestnut-trees, however, were, according to Laurie, away for the afternoon. They found some hickory-nuts, not quite ready to leave their husks, and a few beech-nuts, and after gathering those they sat on a broad, flat boulder and looked down on Orstead and Little Windsor and some twelve miles of the Hudson River, and talked a good deal of nonsense—all except Lee, who went to sleep with his cap pulled over his eyes, and had a cold in his head for days after. George decided that when he was through college and was married, he would come back there and build a bungalow just where they then were.

"This will do for the front door-step," he expounded, "and over there will be a closed-in porch with an open fireplace and a Gloucester hammock."

"That all you 're going to have?" asked Bob. "No kitchen?"

"Oh, there 'll be a kitchen, all right, and a dining-room—no, I guess we 'll eat on the porch. Would n't it be a dandy place, though? Look at the view!"

"Fine," said Laurie, without much enthusiasm, remembering the last uphill mile. "Don't mind if I don't come to see you often, though, do you?"

"Not a bit! Nobody asked you, anyway." "You could live on nuts," murmured Polly. "You could have shagbarks for breakfast and beech-nuts for dinner and—"

"Grape-nuts for supper," said Laurie, coming to the rescue.

"And you could call the place the Squirrel-Cage," suggested Bob.

And that reminded Mae of a story her father had told of a man who had lived in the woods farther down the river some years before, and who ate nothing but nuts and roots and things he found in the forest. "He lived

"Rather! I 've always said that, too. Take George, for example. Just to look at him, you 'd never think he had any sense at all; but at times—"

"Lay off of George!" interrupted that



"THEY TALKED A GOOD DEAL OF NONSENSE—ALL EXCEPT LEE, WHO WENT TO SLEEP"

all alone in a little cabin he 'd built, and folks said he was a deserter from the army, and—"

"What army?" George asked.

"The Northern Army, of course."

"I thought you might mean the Salvation Army. Then this was quite a while ago, was n't it?"

"Of course, stupid! Years and years ago. And finally, when he died, folks found that he was n't a deserter at all, but a general or a major or something, and they found a prize that the Government had given him, some sort of a medal for bravery in battle. Was n't that sad?"

"Well," replied Laurie, doubtfully, "I suppose it was. I suppose the Government would have shown better judgment if they 'd given him a bag of nuts. Of course, he could n't eat that medal!"

"You 're horrid! Anyway, it just shows that you must n't judge folks by—by outward appearances, does n't it?"

young gentleman, threateningly. "If folks judged you by the way you talk, you 'd be inside a nice high wall!"

Why the talk should have drifted from there to the subject of ghosts and uncanny happenings is n't apparent, but it did. In the midst of it, Lee gave a tremendous snore that scared both the girls horribly, and sat up suddenly, blinking. "Hello!" he muttered. Then he yawned and grinned foolishly. "Guess I must have dropped off," he said apologetically.

"You did n't," said George. "If you had, you 'd have waked up quicker! Cut out the chatter; Polly 's telling a spook yarn."

Lee gathered up a handful of beech-nuts and was silent except for the sound he made in cracking the shells.

"It is n't much of a story," disclaimed Polly, "but it—it was funny. It began just after Mama and I came here. I mean, that was the first time. One night, after we had



gone to bed, Mama called me. 'I think there 's some one downstairs, Polly,' she whispered. We both listened, and, sure enough, we could hear a sort of tapping sound. It was n't like footsteps, exactly; more—more hollow, as if it came from a long way off. But it sounded right underneath. We listened a minute or two, and then it stopped and did n't begin again; and presently we lighted a candle and went downstairs, and nobody was there and everything was quite all right. So we thought that perhaps what we 'd heard was some one walking along the street.

"We did n't hear it again for nearly two weeks, and then it lasted longer—maybe two minutes. It got louder, and stopped, and began again, and died away; and we sat there and listened, and I thought of ghosts and everything except robbers, because it did n't sound like any one in the store. It was more as if it was some one in the cellar."

"Well, maybe it was," suggested Laurie.

"That 's what we thought, Nod, until we went to see. Then we remembered that there was n't any cellar!"

"Oh!" said Laurie.

"Mr. Farmer, the lawyer, said what we heard was probably a rat. But I know very well it was n't that. It was too regular. It was always the same each time."

"Spooks," declared George. "The house is haunted, Polly."

"Wish I lived there," said Bob, eagerly. "I 'm crazy about ghosts."

"Oh, but it 's gone now," said Mae. "Has n't it Polly? You have n't heard the noise for a long time, have you?"

"No, not for—oh, two years, I think. At least, that 's what Mama says. Maybe, though, she sleeps better and does n't hear things."

"I guess Mr. What 's-his-name was right," said Lee. "It was probably a rat, or a family of rats."

"Rats would n't make the same sound every time," scoffed Laurie.

"They might. Trained rats might. Maybe they escaped from a circus."

"And maybe you escaped from an asylum," responded Laurie, getting up. "Let 's take him home before he gets violent."

(To be continued)

## FISH CULTURE

By JOHN RICHARDS

"O FISHMAN, gentle Fishman, where do you get your fish,

For the sloppy sea 's a thousand miles away?"

"When the rain comes spitter-spattering, I catch them in a dish, Or a bucket, or a handsome, tinsome tray.

"I transfer them to the bath-tub, which they frequently admire, Because it 's pink and polished all around;

And I stuff them with green angleworms beyond their hearts' desire,

Procured by setting mouse-traps underground.

"When the tunny-fish are thirsty, they have tea in pretty pails;

And I feed the little salmon with a spoon;

And if the smelt are lonely, or the infant catfish wails, I play to them upon the loud bassoon."

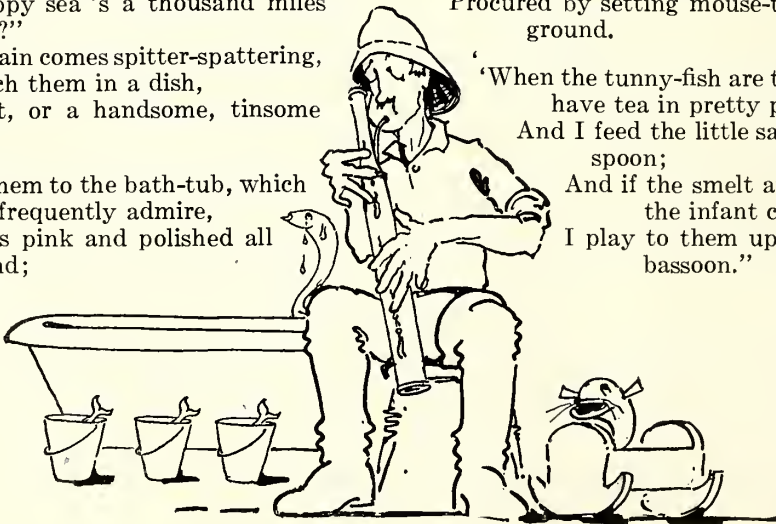

# The Undoing of Morning Glory Adolphus

By  
*N. Margaret Campbell*

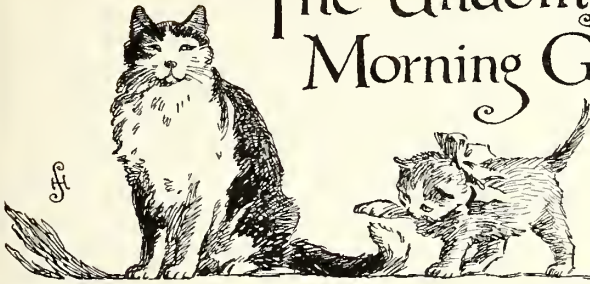

MORNING GLORY ADOLPHUS is our oldest and most sedate cat. He has his own hunting preserves in a wooded ravine at the back of our house, and woe to the cat or dog who invades it. In his early youth he won an enviable reputation as a hunter of big game, and he has his own method of securing due recognition for his exploits. Whenever he captures a rabbit, a squirrel, a water-rat, or a snake, he hunts until he finds his mistress and lays the tribute proudly at her feet. This determination to be cited for bravery and prowess becomes a trifle embarrassing at times, especially when he drags a five-foot snake into the music-room and lets it wriggle on the rug to the horror and confusion of guests. But whatever the hazards, Adolphus is not to be thwarted of due publicity for his skill. If he were a man, he would be accompanied on all of his hunting-trips by a press-agent and would have luncheon with the editors of all the sporting journals upon his return. As it is, without even a correspondence course in advertising, Adolphus manages quite well.

For the study of majestic dignity, tinged on occasion with lofty disdain, interpreters of muscular expression would do well to seek out Adolphus. He walks the highway without haste or concern for his personal survival in the midst of tooting automobiles and charging dogs. When a strange dog appears and mistakes Adolphus for an ordinary cat who may be chased for the sport of the thing, it is the custom of Adolphus to slow his pace somewhat and stretch out in the path of the oncoming enemy, assuming the pose and the expression of the sphinx. He is the carven image of repose and perfect muscular control. Only his slumbrous amber eyes burn unblinkingly, never leaving the enraged countenance of his enemy, who bears down upon him with exposed fangs and hackles erect. When the assault is too ferocious to be in good taste even among dogs, accompanied by hysterical

yapping and snapping, Adolphus has been known to yawn in the face of his assailant, quite deliberately and very politely, as a gentleman of good breeding might when bored by an excessive display of emotion. Usually the dog mysteriously halts within a foot or so of those calm yellow eyes and describes a semicircle within range of those twin fires, filling the air with defiant taunts that gradually die away to foolish whimpering as he begins an undignified withdrawal, while Adolphus winks solemnly and stares



"HE DRAGS A FIVE-FOOT SNAKE INTO THE  
MUSIC-ROOM"

past his cowering foe into a mysterious space undesecrated by blustering dogs.

A few dogs there have been who have failed to halt at the hypnotic command of those yellow eyes. Then there came a lightning-like flash of fur through the air, and Adol-



phus landed neatly on his victim's neck, his great claws beginning to rip with businesslike precision through the soft ears and forehead of the terrified dog. Perhaps the rumor of



"ASSUMING THE POSE OF THE SPHINX"

these encounters spread among the canine population of our neighborhood, for it is never counted against the reputation of any dog as a fighter if he makes a wide detour of the regions frequented by Adolphus.

For years the rule of Adolphus among the cats of his own household has been undisputed. Then came Silver Paws, a handsome young rogue whose satiny coat was beautiful with broken silver and blue lights. There was no question about it, Silver Paws had a way with him with the ladies. While Adolphus still looked upon him as a frolicsome kitten whose sense of humor was unbalanced by a proper sense of dignity, he artfully won all hearts and easily became the center of attraction wherever he appeared. It was plainly disgusting to Adolphus to see the way the conceited young thing arched his back expectantly whenever a human hand came near enough to caress him.

If Adolphus had had the small mind of a punster, he might have observed, after the cynical manner of others who have lost their place in the public affections to an unworthy rival, that the glory was passing out of his name. But he was never one to surrender without a struggle. He went to his nightly hunt with cold murder in his heart and a high resolve to force the spot-light back upon himself. Daily he laid at the feet of his mistress older and wilier rabbits, fiercer-eyed rats, and longer snakes. All to no purpose. He even played the heroic rôle of the deliverer when his hated rival was treed by the grocer's dog. He simply walked calmly up to the tree where the dog was dancing wildly under the limb where the trembling Silver Paws clung, and the dog suddenly remembered that he really ought to catch up to the grocer's wagon and it was n't much fun to bark at a silly kitten, anyway! When the

frightened Silver Paws slid down the tree, Adolphus walked up to him with the self-righteous air of a benevolent gentleman who has rescued a lost soul not because the soul deserved it, but because he himself was made that way. This magnanimous act gave Adolphus a momentary advantage over his rival, but the fickle attentions of the household were soon centered upon the handsome young charmer again. Then Adolphus took to sitting about the house, gazing solemnly past the spot where Silver Paws was receiving the choicest bits of meat with many endearing words, and smoothed his whiskers with a reflective paw.

It was about this time that Silver Paws,



"HE PLAYED THE HEROIC RÔLE OF THE DELIVERER"

to the consternation of the household, disappeared. A search was instituted in the neighborhood, but he was gone without a trace, just as though there had been some witchery abroad and he had been whisked away on a magic broom. Mournfully we gathered up

the playthings he had left scattered over the house,—a bit of fur on a string, a bright-colored ball, some dried beans that rattled in the pod when batted about by a velvet paw,—and of these remembrances we made a heap in his favorite rocking-chair. "He 'll want them if he ever comes back," we said.

A remarkable change had come over Morning Glory Adolphus. We had long honored him as a crafty hunter and a first-rate fighting man, but we had judged him to be somewhat lacking in sentiment, a trifle indifferent and unresponsive, as was natural enough in one who had achieved no small amount of fame. What was our astonishment to find that he had become, overnight, warmly demonstrative in his affections and sympathetically desirous of turning our thoughts from useless brooding over the lost one. It was really touching to see the way he followed us about the house, sitting at our feet to sing with rapturous abandon wherever we happened to pause. Forgotten were the joys of the chase, the pleasant pastime of disciplining unmannerly dogs. For three whole days he gave himself up wholly to the business of love-making. If we attempted to ignore him, he threw himself at our feet and lay on his back at our mercy, as one who would say that he bared his faithful heart that we might kill him if we could not love him. He walked about the house with the proudly possessive air of a haughty ruler who has returned to his domains after an enforced absence, and he curled up blissfully on the cushions where his late rival had been accustomed to take his ease. Once we found him stretched contemptuously over the playthings that lay in a little heap in the rocking-chair. It must have been a bumpy sort of bed, but Adolphus looked happy and comfortable.

Suspicion instantly seized upon his mistress. "Adolphus," she said sternly, "I

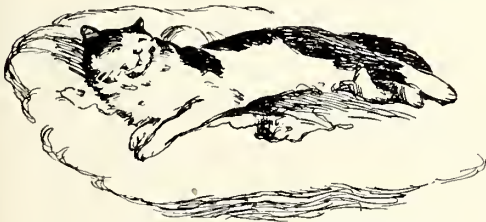

"ADOLPHUS LOOKED HAPPY AND COMFORTABLE"

believe you know what has become of our beautiful Silver Paws!" The accused rose stiffly to his full height, regarded her

with the gravely innocent expression of an outraged deacon, and then, turning his back deliberately upon her, gave himself up again to the slumbers of the just.

But the suspicions of the household were not laid. "Adolphus is trying too hard to



"HE HAD BECOME WARMLY DEMONSTRATIVE"

be good," they argued. "It is not natural. There must be something on his conscience!" For this was Adolphus's way of raising a smoke-screen, as it were, to hide his evil deeds. They had observed this in the past. It was all very humiliating to a proud soul like Adolphus, and he showed his resentment by stalking out of the house and letting the screen-door slam behind him after the manner of any offended male.

The household followed him from afar. He walked straight to the ravine, where he was accustomed to hunt, and stood peering intently down into it over the edge of a cliff, his ears pricked forward, every line of him expressing gloating satisfaction, from his agitated whiskers to the tip of his quivering tail. It was hard to believe that he was the same kindly creature who had been making affectionate advances to us a few hours before. As we drew near we could hear a faint crying, pleading and pitiful, and down among the bushes we discovered our lost Silver Paws, too weak from loss of food to stand, and rather battered from the rough treatment he had received from his jailor.



The moment that Adolphus saw us looking into the ravine he withdrew in disgust, for he knew that his game was up. With lofty scorn he watched us gather up his banished rival, revive him with warm milk, caress, and comfort him. With what dire threats had Adolphus kept his captive down in the ravine, within sound of our voices, all the long hours while he wooed us at his leisure, and what spell had he cast over him that the

hungry kitten had not dared to come at our call?

While we rejoiced and scolded, the grocer's dog was observed coming around the corner of the house. He had grown bold during those days of weakness when Adolphus had been courting the ladies. But one look into the amber eyes of Adolphus, and he was off with a shriek, for he could see that the fighter was once more master of his emotions.



"HE WALKED TO THE RAVINE, AND STOOD PEERING INTENTLY INTO IT"

## THE WORKSHOP OF THE MIND

By HALLAM HAWKSWORTH

### CHAPTER V

#### A NIGHT IN THE LAND OF DREAMS

*Every dreamer has in him this imaginary world. This summit of dreams rises in every brain like a mountain beneath the skies—VICTOR HUGO.*

HAVE you ever read "Mr. Dooley" much? If so, you may remember his story of the night he spent at a friend's house in a Chicago suburb, and how in one place he says:

As I was dhroppin' off to sleep and just beginnin' fer t' wondther how th' last thing I thought of come into me head, a dog barked. Thin a neybour dog tuk it up, and they had a long chat.

And so it went—just one unfamiliar noise and then another—all night long, and poor Mr. Dooley never slept a wink. He goes on to say that he does n't mind the familiar roar of the city and can sleep in the midst of it

all like a baby; but the nightly conversations of the country dogs and the chirping of the crickets and the crowing of the roosters at daybreak—that he could n't stand.

In all of which the famous philosopher of Archey Road made some very suggestive remarks bearing on the little excursion I had planned for my ST. NICHOLAS readers in June into the land of the "Midsummer Night's Dream" and other dreams, as part of our study of the ways and wonders of the mind; and that, no doubt, is why the last thing I thought of—this story of Mr. Dooley's—came into my head.

#### I. WHEN THE CURTAINS OF THE MIND ARE DRAWN

TAKE, for example, Mr. Dooley's remark that he had just begun "fer t' wondther" how the last thing he thought of came into

his head. The scientific students of the mind have also wondered at this thing, and, in their investigations of the subject, have found that we all wander off into the land of dreams in much the same way, in a series of dissolving and apparently disconnected visions. Have n't you often noticed it?

I have a rooster, a fine big, red fellow, of a lordly port and a flowing tail, that repeatedly puts in an appearance just as the sandman is beginning to get me. He comes with a following of matronly hens, casually pecking around, in the way hens do, among the cobblestones of a village street bordered by thatched cottages—apparently a village in England. I don't remember that I ever saw any people about in the little street or in the doors of the houses, so the cottages may be only toys, for all I know. The rooster, though, and the hens are as real as anything.

But here 's a strange thing about him. When he appears, if I say to myself, as I have often done, "Ah, there 's my rooster! I must be going to sleep," that moment I am awake. The rooster vanishes and takes all his wives and the thatched cottages and the cobblestones—everything—away with him; and that 's the last I see of him *that* night! I can look at him as much as I like, so long as my mind is entirely passive. But he simply won't remain and be analyzed. Analysis evidently suggests being carved, or something equally offensive to the rooster mind.

And it is notable how the thinking of eminent men consists not so much in fixing attention on the subject of their thoughts as in shutting out conflicting thoughts and allowing some master idea to monopolize the field. It was this closing of the doors of his mind against outsiders that made Archimedes oblivious of the noise of battle at the siege of Syracuse. There he sat with his bent brows, his mind so occupied with a geometric problem—lost in his day-dream—that he forgot there was any war going on, or anybody about, until the Roman soldiers broke in upon him. Ribot, speaking of the process of attention, says:

Ordinarily, we think of a variety of things together or in close succession. Attention is the shutting out of other ideas or images, in the perpetual procession, for the exclusive benefit of one. It supposes the existence of a master idea, drawing to itself all that relates to it and nothing else; allowing associations to produce themselves only within very narrow limits and on condition that they converge toward a common point.

And just here is one great difference between the dreams of the sleeping and the

waking mind, great as is their similarity in other respects. In sleep, while in the long procession of images we pay attention to some things and not to others,—just as we notice only the striking things as we walk down a city street and are utterly unconscious of other things,—there is usually no master idea to control the comings and goings of these dream images, and they come along as *they* will, not as *we* will—much as if they were real people and had minds of their own.

Yet even the images and ideas of the day-dreams of great men often drop in without special invitation. They come, as Wallace says, "we hardly know how or whence." You saw how it was with the great Kepler and his day-dreams, some of them pretty wild; and what Faraday said about letting the imagination go and then checking it up with the facts. The attitude of the thinker, the dreamer, is passive, but his master idea, his habitual line of thought, keeps an eye on things.

I remember in reading Herbert Spencer's autobiography being particularly struck by a conversation he records as having taken place between George Eliot and himself. She happened to speak of the fact that his forehead showed no wrinkles, and observed that this was strange for a man who did so much thinking and on such profound subjects.

"I suppose it is because I am never puzzled," said he.

"Oh," exclaimed the distinguished novelist, for they were very close friends, "that is the most arrogant thing I ever heard!"

"Not at all, when you know what I mean."

He then proceeded to explain the processes of his mind, and, in connection with his report of the conversation, in his autobiography says:

The conclusions to which I have come, from time to time, have been arrived at unaware and as the legitimate outcome of a body of thought which slowly grew from a germ. Some direct observation or fact met with in reading would dwell with me, apparently because I had seen its significance. A week later, possibly, it would be remembered; and further thought about it would lead to the recognition of some wider application than I had at first perceived. Thus, little by little, in unobtrusive ways, without conscious attention or appreciable effort, would grow up a coherent and organized theory.

So the mind often does its best when we seem to get outside of it and look in, as quiet spectators of its goings-on. That 's why so



many things come to us after we go to bed that we could n't for the life of us think of when we tried during the day.

Burns composed his famous lines to the field-mouse after he had gone to bed at the end of the day's plowing, during which he had inadvertently turned the poor little creature out of house and home. "Very numerous" says Ribot, "are those who think horizontally."

But whether lying down, as Darwin constantly did, or walking the fields, as Wordsworth and Tennyson did, or the London streets as Dickens did, a state of day-dreaming is characteristic of creative minds. Many people, you know, can't sleep away from home—dogs or no dogs. Everything may be as comfortable as possible, but the mind is uneasy, like a cat in a strange garret. It is for this reason that many famous men could not work without their familiar tools, materials, and surroundings. Handel found the graveyard of some village church his most congenial place for composition, but Haydn had to be in his best clothes, with his hair carefully dressed and a certain diamond ring which Frederick II had given him placed on his forefinger, before he could summon a single note.

The famous French essayist Montaigne would never sit down to write without a favorite cat at his elbow. Pussy, in fact, seems to have cut quite a figure in literature. Rough old Dr. Johnson compiled his dictionary with the help of a purring cat on the table.

But all of these and similar things merely mean that the familiar habits and surroundings make the outside self feel at home, so that it does n't get restless and disturb the inner, the thinking mind. Newton the outer man and Newton the inner man—the dreamer—were two such different individuals that while, as an astronomer, he was one of the greatest of mathematicians, he could n't even make change correctly. He had to depend on the honesty of tradesmen with whom he dealt.

The extent to which such men lose themselves in their work is incredible. Ampere, the French scientist whose name, as everybody who studies electricity knows, designates an electrical unit of measurement, was one day thinking out a formula, and, with a piece of chalk which he always carried in his pocket for such purposes, began writing it out on a blackboard which stood conveniently by. The "blackboard," however, turned

out to be the back of a cab, and when it started to move away, Ampere, accepting the situation in the matter-of-course way with which one accepts strange things in dreams, not stopping to reason why a sober and staid blackboard should behave like that, chased after it for many weary blocks. Finally, owing to a halt on the cabby's part, he caught up and, awakening to the outer world and explaining his mistake, recovered his precious formula.

This kind of thing, this absence-of-the-other-mindedness, may even go so far that one self may be in severe pain and yet the other self will go on with its business as if nothing were the matter. Take the case of Pascal, as instanced on this point by Taine:

There are numerous instances in which, under the empire of a ruling idea, all other sensations, however violent, are annihilated; such, for instance, is the story of Pascal, who one night solved the problem of the cycloid to distract himself from a severe tooth-ache. These authentic instances all bring to light the same fact, the more or less complete canceling of all sensations, images or ideas, in favor of a single one.

The great orators, like the great writers and the great actors, carry their audiences away with them into the scenes of their fancy. Who has n't cried or laughed or become indignant over a story or a play, as if the whole thing were real?

Although there are some well authenticated instances of important work being done in the dreams of sleep, great men do their best dreaming, as a rule, when they are awake. Their average dreams in sleep seem to be of no higher grade than those of the rest of us. For instance, one man dreams that he is dead; that the undertaker drops a board he is measuring for the coffin. The noise wakes the sleeper to hear a blow of the hammer with which a carpenter is mending his garden fence. It was this noise that started and ended the dream. Who could n't dream as good a dream as that? And who, do you suppose, did that one? Charles Dickens. Yet he did it with precisely the same mind and the same dream machinery that created "The Chimes." The difference was, that in the case of the undertaker, the workman himself, the waking Dickens, was not in the shop and the machinery was running wild.

So the more we look into it, the more evidence we find that the creative imaginations of the extraordinary mind are simply the dream machinery of the ordinary mind that has been given a definite piece of work to do. Like other geniuses, young people





Painted by N. Barabino

Published by J. Casper

"ARCHIMEDES OBLIVIOUS TO THE NOISE OF BATTLE AT THE CAPTURE OF SYRACUSE"



have much more vivid imaginations than the average adult, and, therefore, more vivid dreams. Of the vivid dreams of young people of the high-school age, Dr. Hall says:

One dreams of a fire, and inquires about it next morning; of a present, and searches the house for it next day; delays breakfast for a friend who arrived the night before in a dream.

## II. THE DUST THAT DREAMS ARE MADE ON

SHAKESPEARE says we are "such stuff as dreams are made on"; but he does n't say what stuff the dreams themselves are "made on." That, it seems, was reserved for the modern psychologists. They have, among other phases of the workings of the mind, made such a study of dreams that, just at present, there is no branch of mental science that is so much talked about.

And what do you suppose they say, these dream experts? Why, they turn what Shakespeare says right around. The psychologists tell us that dreams are made on such stuff as we are made of—that is, dust! Not the same kind of dust, to be sure, but dust,—“visual dust,” Professor Bergson calls it,—those little brilliant points of light and spots of color that we see against a dark background when we close our eyes. The psychologists call these little things “phosphenes,” and it is around them that the images that are the dramatis personæ of our dreams, the characters in our night shows, gather and play their parts.

If, the distinguished professor of the Collège de France goes on to say, we acquire the habit, as did Professor Ladd of Yale, of keeping the eyes closed on awakening from a dream, we can see the images melt away into phosphenes.

But then, as Stevenson says, the world is full of a number of things! You could n't tell me, for instance, if I had n't seen it hundreds of times, that plain little seeds, that don't look like anything in particular, could be the treasure-houses of all the wonderful forms and colors and perfumes that we know *do* grow out of seeds—and all just by putting them away in the dark for a while. Or what is more unlike a chicken than a chicken's egg—in shape or color or substance or anything? And yet what the egg is to the chicken, the acorn to the oak, those little golden lanterns are to the visions of the night, moving forward, as if carried by invisible fairy dancers, to light the way into the land of dreams. It is around these lights, as we have just learned, that the dream images gather; it

makes no difference whether the origin of the dream is internal—as on the night after Christmas—or external, suggested by something outside of ourselves, as in the case of one of his own dreams that Professor Bergson tells about. As head of the department of philosophy of the Collège de France, he is constantly delivering lectures to his students and to other people from all over the world, who go to hear him when they are in Paris. One night he dreamed that he was making a political speech in a hall somewhere, in the course of which he evidently said something the audience did n't like; for first there came a growl of disapproval; the growl grew louder; rose to a mighty roar; and then he heard from all parts of the hall, shouts of:

“Out! Out!”

That woke him up and he was, no doubt, pleased to find that he was in his nice warm bed at home and that nobody was thinking of putting him out at all! It was only a neighbor's dog, saying “Ouf! Ouf!”—or whatever it is that French dogs say when they want to bark.

But anyhow, you see if *Mr. Dooley* had been sound asleep, instead of half awake and in an analytical mood,—“beginnin' fer t' wondther,”—he might have taken those dogs right into his dreams and had a fine time with them.

Here 's another interesting case of the external hint that starts the internal dream. A certain man was asleep one morning—when he should have been dressing for breakfast, I imagine. His wife, thinking to play a little joke on him, sprinkled some water in his face. But what do you suppose *he* had thought before he came out of the land of dreams? He thought he had passed through the events of an entire lifetime, “during which happiness and sorrow were mingled,” and which finally ended in a desperate struggle with an enemy on the borders of the sea, into which his adversary finally flung him! All this between the moment when the water was sprinkled on his face and the moment when he awoke!

Webster once fell asleep in court while listening to one of the opposing counsel reading a citation from a law book. He dreamed a dream which seemed to last for hours, but woke in time to hear the conclusion of the paragraph, which was quite brief.

We dream so fast because most dreams are merely a succession of pictures—Flash! Flash! Flash! Each picture is suggested by and grows out of the one which precedes it; and

each, after remaining a moment in view, fades away as its successor goes on with the story. The process has been compared to the torch race of the Greeks, in which each runner was joined by the next in order along the course, the new relay accompanying him until he had caught full speed, and then taking the

Just at this point in the narrative the poet fell asleep and so remained for the time above stated, during which he had the most vivid impression that he had composed between 200 and 300 lines. The images of this picturesque fragment rose up before him, he says, as realities, "with a parallel production," I am



AMPERE PURSUING HIS RUNAWAY FORMULA

torch and going on, while the other dropped behind.

Another reason why dream stories get on so fast is that these dream stories are usually like the silent drama we call "the movies"; no words are spoken. Coleridge's dream in which he composed "Kubla Khan" was one of the exceptional instances in which words played a part; and, accordingly it was an unusually long dream.

In your study of English literature you have doubtless read the story of it. This famous nap took place in an arm-chair and lasted some three hours. Here, in brief, is the story of the dream and the dust that the dream was made of. The dust—with the help of the phosphene's as a nucleus, of course—consisted of these two sentences from "Purchas's Pilgrimage": "Here the Khan Kubla commanded a palace to be built and a stately garden thereunto. And thus ten miles of fertile ground were enclosed by a wall."

quoting his own words, "of the corresponding expressions without any consciousness of effort." On awakening, he seized pen and paper and wrote the lines we find in his works. Unfortunately, he was interrupted to attend to some business matters, and when he returned to his room in the farm-house overlooking the desolate moors of northeast Devonshire where he was staying at the time, this dream of "the stately pleasure dome," and all the words that went with it, had vanished quite away! Yet, even as they stand, the fragments of the ruined dream are evidently the product of a great imaginative mind.

Now, by way of contrast, take some lines from another dream poem. The story of it is related in Carpenter's "Art of Creation":

An acquaintance of mine, who was accustomed to keep pencil and paper by his bedside for such occasions, told me that he once woke in the night feeling himself drenched with a sense of seraphic joy, while at the same time a lovely stanza, which



he had just dreamed, lingered in his mind. He wrote it down and fell asleep again. In the morning, waking and turning to look at the words, which he doubted not would make his name immortal, he read:

Walker with one eye,  
Walker with two,  
Something to live for,  
And nothing to do.

Which only goes to show that it takes a good deal more than a handful of "visual dust" to create dreams that live. There have been very few literary creations of the dreams of sleep that anybody ever heard of; or, having heard, ever wanted to hear again. They seldom represent the author's best work, even in the case of men like Coleridge. But while it is true that the productions of great minds are dreams—day-dreams—produced by the same kind of machinery that turns out your wonderfully vivid dreams of the night—and in much the same way, one idea passing on the torch to the next; yet there is the vital difference that the higher faculties, the judgment and the will, are "on the job." Like diplomatic stage-managers, they direct the show without interfering too much or too obviously with the temperamental actors.

Take Coleridge again and his "Rime of the Ancient Mariner." That poem, it so happens, was founded on a dream, the dream of a friend of his; but the original dream was nothing at all compared to the finished product, which was put together deliberately by the practised hand of a great artist and for the prosaic purpose of helping to pay the expenses of a walking tour on which Coleridge was accompanied by Wordsworth and the latter's devoted sister Dorothy. This is from Wordsworth's own account of the origin of this masterpiece—one of the masterpieces of all time:

Mr. Coleridge, my sister, and myself started from Alfoxden pretty late in the afternoon, with a view to visit Linton and the Valley of Stones

near to it; and as our united funds were small, we agreed to defray the expense of the tour by writing a poem to be sent to the "New Monthly Magazine." Accordingly, we set off and proceeded along the Quantock hills toward Watchet; and in the course of the walk we planned the poem of "The Ancient Mariner," founded on a dream, as Mr. Coleridge said, of his friend Mr. Cruikshank.

The most famous dream in literature, of course, is Shakespeare's midsummer fantasy. It is in this very poem, by the way, that we find the famous lines about the typical poet, his "eye in fine frenzy rolling" and giving to "airy nothings a local habitation and a name." But Shakespeare is here simply putting into the mouth of *Theseus* the popular conception of the artist as one who makes things out of "blue sky"—something out of nothing. As a matter of fact, no artist ever served a more thorough apprenticeship to his craft than the author of these lines; none was ever more careful in laying out his plans and gathering material and aiding his imagination in every way. His methods were much more like those of the architect than of the frenzied person he describes.

Part of Shakespeare's apprenticeship, during his boyhood, was unconscious; all of it, after he became a writer, was conscious. References are found in the "Dream" to the fantastic pageants with which Queen Elizabeth was entertained at Kenilworth Castle when Shakespeare was a school-boy. Kenilworth was only fifteen miles from Stratford, and what would a husky lad like Will Shakespeare think of walking that distance to see things so magnificent? Not only the "Dream," but other early work is notable for its accurate and loving references to the birds, flowers, and trees of his boyhood. The plots, hints, ideas, and characters which he drew from the works of others served as collecting centers, "visual dust" for the memories of his teeming brain to gather around, including memories of moonlit woods and the moonlight people of elfland, the traditional superstitions of the country-side. As for the plot, he obviously got many ideas from Chaucer's "Knight's Tale." That the whole conception of *Puck* was gathered from the popular notions of the time is shown in many of the lines. In one of the books of the time, that Shakespeare no doubt read, we find it gravely recorded:

And if that the bowl of curds and cream were not duly set out for Robin Goodfellow (*Puck*), why, then either the pottage was burnt next day in the pot or the cheese would not curdle or the butter would not come.

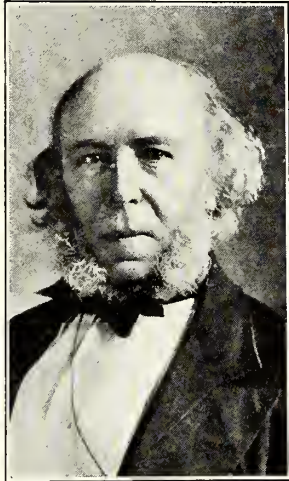

Courtesy D. Appleton & Co.  
HERBERT SPENCER

Now compare this with *Puck's* own account of his mischievous occupations in Act II, Scene I of the play.

Such is the origin of this wondrous dream of fairyland; the land where, "through dim woodland vistas, the moonbeams struggle with the dust and elfland opens into sight, ethereal, impalpable, spun of gossamer and dew." Back of the beautiful scenery and the drop-curtains and the furnishings of the stage and the glowing footlights, are the ropes, the stage machinery, and the framework of things put together with hammer and nails. So back of the beautiful things of the poet and the painter and the story writer, are the plots and the blockings out, the anatomy of their dreams.

But so great becomes the artistry of these

artists that you would never suspect, from the finished product, how the framework of it was put together, with careful, plodding industry, carpenterlike, methodical, and with the use of foot-rules, too—there are to be so many chapters, in the case of stories and plays; so many figures and disposed thus and so, in the case of pictures.

From all this it is plainly to be seen that dreaming is a very important business if properly attended to. And the kind of dreams we have been speaking of are far more substantial, more lasting, than the great fortunes of men and their "cloud-capped towers," their "gorgeous palaces"; for these dreams endure when the merely material things have dissolved and "left not a wrack behind."

## SUNLIGHT IN THE WOODS

(As Told by Nicky)

By COMFORT GILDER

I WAKE up, yawn, and stretch. The sun is up ahead of me. Its light is on the water. The lake is very still. There is no sound. Not even a leaf is stirring. Now little breezes are whispering to the pine-needles. The firs shake themselves. A leaf flutters softly to the ground. All is still again. The smell of the woods and the ferns fills the air. A chipmunk has passed. His scent floats to me. The trees are swaying slightly. A ripple stirs the water. I hear the air breathing faintly through the leaves. It is beautiful. Why stay in bed? I long to jump up, to run and play with her. Will she ever wake up?

I look across the tent at her. She is still sleeping. Her eyes are closed and she is breathing peacefully. I must not wake her. I will jump down softly and tiptoe to her cot. I gaze on her and sniff her fragrance—like balsam. She is beautiful, and the sun is in her hair. When she wakes, her eyes will dance—but I must not wake her.

I hear a squirrel chirping. I run out on the platform of the tent and listen. Two of them are scolding each other. How funny they are! What is the use of so much talk! I wonder what they are saying? There goes one! I leap from the platform on to

the cool, moist ground and bound toward him. He scampers up a tree. I hear him chattering and bickering up there somewhere. He is a fool. I trot back to the tent and stand still, listening, my ears bent forward, my tail rigid, every nerve in my body tingling. I hear a bird singing, and all the sounds of living things. I long to bark for joy—but she is sleeping still.

Will she ever wake up? She loves to run in the woods with me. We bound on together, jump over logs, dash down the little hills, panting, laughing—happy, happy! But now—will she ever wake up? The day will be over and the sun going down and all the little noises in the woods will go to sleep; and we are missing so much!

I go back inside the tent, and lie down by her bed and wait. I try to sleep. I can not. My eyes are on her face. Everything is awake—every animal, every growing thing, every sound, every smell—they are all calling us; but she is dreaming still.

She must not miss it! I can not let her. I rush back to her cot. My paws are on her blanket. I kiss her face. She opens her eyes and smiles. I feel the softness of her touch on my head. I make small sounds of delight and hold her hand gently in my mouth. She



is laughing and saying sweet things. Her voice thrills in my ear. I scamper about the tent, prancing—barking at last. And now she is out of bed in one bound, running around the tent laughing and dancing, for I have stolen her slipper and she is playing with me.

I AM barking and jumping in the air for joy. We are going walking! I can see it in her eyes, hear it in her voice. She is laughing and her eyes are shining.

She is putting on her green suit. I sniff it. I smell oil and grease very faintly. I remember 'way, 'way back when we were over there together in that country where I was born and where she found me. There, in that big heavy truck, all day, sometimes all night without lights, I sat at her feet, listening to the noisy purr of the engine or to the terrible cannon, sometimes near, sometimes far. We passed through cities, through country along dusty, bumpy roads. We moved among soldiers pushing on toward the cannon and wounded ones returning. And still we traveled, our car loaded with boxes, supplies, sometimes with wounded men. Finally,—watching, listening, smelling,—I would drop off to sleep at her feet, still on guard; but she would go on and on, without sleep, without food.

At other times, she worked under the car, and I lay near by waiting and watching. I remember once when she was struggling with a heavy pan under the car. A line of those green, dirty men, with hanging heads, our enemies, guarded by our soldiers, came tramping down the road. The next thing I knew, two of those terrible men were lying under the car, one on each side of her, helping to lift the pan.

I was filled with horror. She commanded me to lie still, and I lay there quivering with rage and despair. Was she safe? I smelt their loathsome boots. If I could dash under the car and tear their throats! I could only snarl and growl. I could see the twinkle in her eyes. She was laughing. I could not understand.

But that was long ago. Now we are running together through the woods. The leaves rustle under our feet. They flutter about us and on our heads as we speed along; they are gay colored and dance in the sun. The firs are dark behind them. We run on and on together. It is like flying when we leap over logs. She stops and listens. The woods are full of the wonderful noises of birds, chipmunks, squirrels, of swaying trees,

whispering firs, and fluttering leaves. We watch. We listen. Suddenly, a keen scent comes to me on the breezes. A deer! I dart ahead. I am on his track! I hear his snort of fright as he crashes through the branches. What sport! I see his white tail disappear among the trees. He is gone!

I run back, panting, to meet her on the trail. Where is she? I hear her step, smell her fragrance. Now I see her before me, the sunlight on the path! I bound to her and look up at her face. She laughs. Her voice is like music. It echoes in the woods. Now we are pushing forward again. Why can't we go on forever like this!

SHE told me to lie here on the dock and wait. I am obeying. I see the sail far away, a little speck on the lake. I have strained every nerve to hear her voice again, to smell her scent. All has gone. There's nothing but water, water—lonely and cold. I hate it. I hate the feeling of it. I hate the sight of it. I hate the noise it makes.

Will she ever come back? It has been so long since she left. I am afraid for her. Why does she ever have to leave me?

I am here alone. I can do nothing. If only I could follow her—but she told me to wait. And there is water—broad, deep, dangerous—between us.

I can't bear it. I jump up and bark and bark. Only the echo answers. It laughs back at me.

I despise the silly little waves splashing on the shore. I hear the mournful wind in the pine-trees. A squirrel is daring me to follow him—I do not heed him. I am waiting to hear her voice again.

Do I hear her laughter? I see the white sail, a tiny thing. It is growing larger. She is coming! She is coming! Now I hear her voice distinctly. It comes to me clearly over the water. I have forgotten the wind, the waves, the water. She is coming back to me! She will be here soon, on land again.

Now I see her close, breathe the air full of her fragrance. I thrill with happiness. I am barking wildly and leaping into the air. I kiss her hand. She is scolding me sweetly for making so much noise: I can not help it. My tail thrashes against her skirt. I hear her voice again! She is on land with me. I am near her, by her side, at last!

THE canoe is gliding slowly through the water near the shore. There are three of us. He is paddling. If only he does not talk!



"I RETURN TO THE WATER'S EDGE AND SEE THE CANOE FLOATING TOWARD ME'"



All is quiet. The paddle is always in the water, but it makes no sound. The lake is calm. The peaceful woods, brilliantly colored, look at us from the water. Her eyes are bright. The sunshine is lighting her hair. Her sweater is like young grass. How beautiful she is! I lie very still at her feet and look up at her.

Now we have reached the inlet, where the narrow stream flows into the lake. The trees hang over us as if we were on a broad path in the wood; but instead of traveling on a rough trail, we glide along smoothly and there is no rustling of dead leaves under our feet.

The woods are full of hushed noises and fresh smells. We move so quietly that nothing hears us: everything is awake and whispering. My nose picks up scents. I sit up carefully and sniff. I long to jump ashore. I look up at her, begging. She motions me to go. The canoe rocks as I leap from it into the woods. I quickly explore the nearest thicket.

I return to the water's edge and see the canoe floating softly toward me. She sees me. She smiles. I step with care into the canoe. How could I have left her even for a moment!

The man is leaning forward and talking. She is listening to him. I do not want him to look at her that way. I do not like the sound of his voice, nor his scent. Does she need me? I growl and creep as close as I can to her. How can I screen her from him? She smiles and lays her hand on my head. She scolds me softly. I stop growling. She speaks to him. He turns to his paddling; but I do not trust him. I watch him steadily.

The sky is clouding. A chill is in the air. The trees are shivering in the wind. The paddle splashes as we hurry home in the fading light. I am hungry.

SHE sits between the fire and the lighted lamp. I lie dozing at her feet. She closes her book with a slap. I jump up and stand by her side. It is time to go to bed. My eyes blink with sleep. My legs sway beneath me. She is still talking to the others. Why do they talk so much? Will she ever go to bed?

She is walking to our tent, a lantern swinging from her hand. I am following close behind.

We enter the tent. She opens her trunk. She bends over it. My tail hangs between

my legs. Shivering, I look up at her. She pats my head. I see by her sadness that it is true—we are soon going away. Why must we leave this place, where we are free and happy, with the woods to play in, the wild animals to chase, the delicious smells? And we go—where?

I was in that city once. I remember only ugly, rattling noises—crashes, yelling, the sound of horns. The air was full of town smells, of grease and dirt, of choking gas. The roads were hard, full of people stepping all over you. The houses were piled high on each other, with the sky far away and small. In those streets I was afraid and cowered close to her.

Yet I had rather be there, wearing a hateful muzzle, and at the end of a chain, by her side, than in the woods alone.

But is she surely going to take me with her? I tremble at the thought of being left behind. I cling to her side and whine softly. She speaks to me, but I do not know what she means. Why can I not always understand her? Why can she not always understand me? Her voice, her smile seem to tell me that she will not go without me. If I could only be sure!

She pats me and tells me to go to bed. I leap up on my cot and roll myself into a tight ball. I am cold and lonely. She takes a blanket from her cot and tucks me in. She speaks to me tenderly. She smiles. I love the sound of her voice, the radiance of her smile.

I am very sleepy, but she is still awake. I must keep my eyes open a little longer.

The wind is blowing through the trees. The tent flaps shake. The rain begins to fall. The trees sway and moan; the storm will not let them rest.

I smell the wet leaves and damp earth. I hear the splashing of the waves on the shore. Now the rain is beating fiercely on the canvas. The gale rushes through the trees, making shrill noises, sometimes rising, sometimes falling. The tent seems to sway gently like the trees. I am so drowsy that I can hardly keep my eyes open. Will she ever go to sleep!

I listen for her breathing. At last she is asleep. Now I can also sleep. But I am here close beside her, ready if she needs me. I will protect her through the night, as I have all day. Any strange scent, any unusual sound, and my eyes will open. Awake or asleep, I will guard her always.



# THE TARDY SCHOLAR

by Ellen  
Narly



“PLEASE let me tell you, Teacher dear,  
The reason why I'm late.  
First, Rose and Lily made me stop  
Before I reached the gate.

“Then, just a little farther on,  
Sweet William caught my eye,  
And dear old Ragged Robin, too—  
I could n't hurry by.



“Then Johnny-Jump-Up, by the road,  
Was peeping from the grass  
With such a smiling little face—  
Of course, I could n't pass!

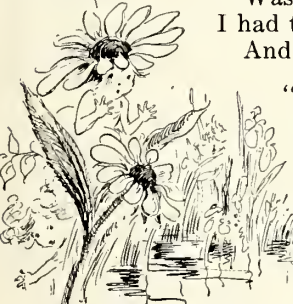

“Next, Daisy, from a clover-field,  
Was beckoning to me—  
I had to climb the fence at once  
And go to her, you see!



“And Black-Eyed Susan, by the brook,  
She tempted me to stay;  
And there I found so many friends,  
I could n't get away.

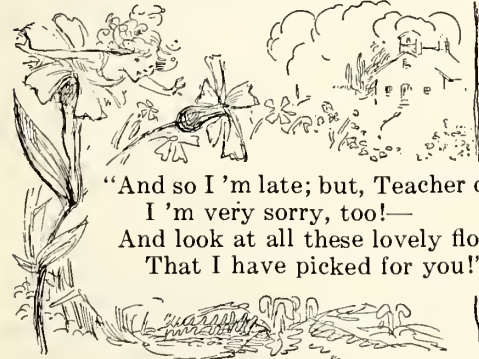

“Then, when I'd nearly reached the school,  
Whom do you think I met,  
In sweetest dress of pink and white,  
But pretty Bouncing Bet!



“And so I'm late; but, Teacher dear,  
I'm very sorry, too!—  
And look at all these lovely flowers  
That I have picked for you!”

Judium  
12



# THE BLUE ENVELOP

By ROY J. SNELL

## CHAPTER VIII

### RENEWED ACQUAINTANCE

No wildest nomadic dream could have exceeded the life which the two girls lived in the weeks that followed.

Trailing a reindeer herd over hills and tundra; camping now in a clump of willows by the glistening ice of a stream, now beneath some shelving rock, and now on the open wind-swept tundra itself. Eating about an open fire, while the smoke curled from the top of the dome of the tepee-like igloo, they reveled in the strange wildness of it all. Here were a people who paid no rent, no taxes, owned no land, yet lived always in abundance. In the box beside the sleeping-platform was tea and sugar. Over the fire hung a copper tea-kettle of ancient design. In the sleeping-box, which was made of long-haired deerskins, were many robes of short-haired deerskin, fawn-skin, and Siberian squirrel.

To all these the two girls were more than welcome. The stranger and his daughter did not live alone. A little tribe whose twenty igloos dotted the tundra traveled with them. These people were sometimes in need of simple remedies. For these they were singularly grateful. They, their women, and their children posed interestingly for sketches. But one thing Marion had not taken into consideration—these people seldom visited the village of East Cape. Although she did not know it, their herds were at this time feeding away from this trading metropolis of the straits region. Each day, while she seized every opportunity to sketch and hastened her work as much as she could, found them some ten miles farther from East Cape.

When at last, by signs and such native words as she knew, she indicated to her native friends that she was ready to return to East Cape, they stared at her in astonishment, and indicated by a diagram on the snow that they were now at a point three days' journey from that town; that none of them expected to return before the moon was again full.

No amount of gesturing and jabbering could make them understand that it was necessary for the girls to return at once.

"We 'll never get back," Marion mourned in despair; "and it 's all my fault."

"Oh, we 'll make it still," encouraged Lucile, cheerfully. "Probably the straits are not fully frozen over yet, anyway."

But days passed. Four, five, six of them dragged wearily past, with no sign of preparation for a trip to East Cape. Driven to desperation, the girls were considering a mad attempt to reach the port alone, when a remarkable thing happened. They had just dressed and were frying reindeer chops for breakfast, one morning, when a round face was thrust in at the tent-flap and a cheery voice cried,

"Hello!"

For a moment they did not recognize the boy; then, with a breathless whisper, Lucile gasped, "Why! it 's our man Friday of Muntineer's Island!"

And so it proved to be. The boy had learned to speak English brokenly during his sojourn in America. He had found his way back to his home on the north coast of Russia, and was now living with his own people. News travels far. He had heard of two strange white people living among the reindeer Chukches. He had traveled two hundred miles to see them.

"And now," he smiled, "now it is my very good friends, who save me much time ago."

The girls did not waste many moments before telling him their predicament. He set to work at once to assist them. Not three hours had passed when they found themselves again speeding over the snow, behind reindeer driven by their man Friday of other days.

It was a hard trip, with many an overturned sled and one terrible blizzard, which came howling down from the north, but in time they came in sight of the jagged slope of the hill that marked the spot where the little village nestled.

"Phi" met them at the outskirts of the town.

"Are—are we too late?" Marion's heart was in her mouth.

The boy smiled an odd smile.

"About six hours, I 'd say."

"Six hours?"

"His nibs, the old Chukche guide, left for Cape Prince of Wales and all suburban points some six hours ago. Some one offered him more money than I did. I have a fancy it

was your friend, the bearded miner, who wanted my mail."

"And—and you waited for us?"

"Naturally, since the guide left."

"But you could have gone sooner?"

"Some three days, I'm told."

"But you did n't?"

He smiled and shrugged his shoulders.

Marion's head whirled. She was torn between conflicting emotions. Most of all, she felt terribly ashamed. Here was a boy she had not fully trusted, yet he had given up a chance to escape to freedom, and had waited for them.

"I—I beg your pardon," she said weakly. She sat down rather unsteadily on the reindeer sled.

"We could n't help it," she said presently, "They just would n't bring us back. Is n't there some other way?"

"I've thought of a possible one. I'll make a little try-out. Be back in an hour."

Phi was off like a flash. A couple of minutes later, the girls thought they heard him calling old Rover, who had been left in his care.

"Wonder what he wants of him?" said Lucile.

"I don't know," said Marion; "but I do know I'm powerful hungry. Let's go find something to eat."

## CHAPTER IX

### FINDING THE TRAIL

"I THINK we can go," Phi smiled as he spoke. His hour for a try-out had expired. He was back.

"Can—can we cross the straits?" Marion asked, breathless with emotion.

"I think so."

"How?"

"Got a new guide. I'll show you. Be ready in a half-hour. Bring your pictures and a little food. Not much. Wear snow-shoes. Ice is terribly piled up."

He disappeared in the direction of his own igloo.

Marion looked about the cozy deerskin home where were stored their few belongings; then gazed away at the masses of deep-purple shadows that stretched across the imprisoned ocean. For a moment courage failed her.

"Perhaps," she said to herself, "it would be better to try to winter here."

But even as she thought this, she caught a vision of that time when she and her companion had been crowded out of a native vil-

lage to shift for themselves. Then, too, she thought of the possible starving-time in the spring, after the white bear had gone north and before walrus would come, or trading schooners.

"No," she said, "no, we'd better try it."

When the girls joined Phi on the edge of the ice-floe, they looked about for the guide, but saw none. Only Rover barked them a welcome.

"Where—where's the guide?" asked Lucile.

"You'll see. Come on," said the boy, leading the way.

For a mile they traveled over the solid shore-ice. They then came to a stretch of water, dark as midnight. At the edge of this was a two-seated kayak.

Phi motioned Lucile to a seat. Deftly he paddled her across to the other side. It was with a sinking feeling that she felt herself silently carried toward the north by the gigantic ice-floe.

Marion and the dog were quickly ferried over. Then, after drawing the kayak upon the ice, the boy turned directly north and began walking rapidly. At times he broke into a run.

"Have to make good time," he puffed, as he snatched Marion's roll of sketches from her hand. "Got to get the trail."

They did make good time. Alternately running and walking, they kept up a pace of some seven or eight miles an hour.

"Why, I thought—thought we were going to go east," puffed Marion. "We're just going down the beach."

Phi did not answer.

They had raced on for nearly an hour when they suddenly came upon a kayak drawn up, as theirs had been, on the ice.

"Ah! I thought so," said the boy, "Now's the time for a guide. Here, Rover!"

He seized the dog by his collar and set him on the invisible trail of the men who had deserted that kayak. The dog walked slowly away, sniffing the ice as he went. His course was due east. The three followed him in silence. Presently his speed increased. He took on an air of confidence. His tail went up, his ears back. He sniffed the ice only now and then as he dashed over great flat pans, then over little mountains of broken ice, to emerge again upon flat surfaces.

Marion understood, and her admiration for Phi grew. He had found the trail of the men who had crossed the straits before them. He had put Rover on that trail. Rover could



not fail to follow. The trail was fresh, only seven hours old. Rover could have followed one as many days old.

"Good old Rover!" Marion murmured, "Good old Rover, a white man's dog!"

All at once a question came to her mind. They had been obliged to go several miles north to pick up the trail. This was due to the movement of the floe. This movement still continued. It was carrying them still farther to the north. The Diomed Islands, half-way station of the straits, were small—offered a goal only two or three miles in length. If they were carried much farther north, would they not miss the islands?

She confided her fears to Phi.

"I thought of that," he smiled. "There is a little danger of that; but not much, I guess. You see, I'll try to time our rate of travel and figure out as closely as I can when we have covered the eighteen miles that should bring us even with the islands. Then, too, old Rover will be losing the trail about that time. When that bearded friend of yours and his guide leave the floe to go upon the solid shore-ice of the islands, the floe is going to keep right on moving north. That breaks the trail. See? When we strike the end of that trail we can go due south and strike the islands. If the air is at all clear, we can see them. It's a clumsy arrangement, but better than going it without a trail."

Marion did see, but this did not entirely still the wild beating of her heart. It was with a strange, wild thrill that she realized they were far out over the conquered sea. Hundreds of feet below was the bed of Bering Strait. Above that bed, a wild, swirling current of frigid salt water raced.

Once, as they were about to cross a stretch of new ice, Phi threw himself on his stomach and hacked a hole through the ice. Water bubbled up, while Marion caught the wild surging rush of the current.

For a second her knees trembled, her face blanched.

Phi saw and smiled.

"Never fear!" he exclaimed. "We'll make it all right. And when you get back home, you'll have a story to tell that will make Eliza's crossing of the river on the ice seem a mere picnic party crossing a trout-stream on stepping-stones."

It was not long after that, however, when even this daring boy's face sobered. Old Rover, who had been following the trail unhesitatingly, suddenly came to a halt. He turned to the right, sniffing the ice. Then he

turned to the left. After that he looked up into the face of the boy, as if to say, "Where's the trail gone?"

Phi examined the ice carefully. "Been a sudden jam here," he muttered; "then the ice has slid along, some north, some south. It has all happened since our friends passed this way. You just wait here. I'll take Rover to the north and let him pick up the trail. When I find it, I'll come back far enough to call to you. Maybe to the south; we'll see."

He disappeared around a giant ice-pile.

The two girls, placing their burdens of food and Marion's sketches on an up-ended ice-cake, sat down to wait. They were growing weary. The strain of the adventure into this puzzling unknown ice-field was telling on their nerves.

An hour passed, but no call echoed across the silent white expanse. Marion, now pacing back and forth across a narrow ice-pan, now pausing to listen, felt her anxiety redoubled by every succeeding moment. What could have happened to Phi? Had some mishap befallen him? Had a slip thrown him into some dangerous crevice? Had thin ice dropped him to sure death in the surging undercurrent? Or had he merely wandered too far and lost his way?

Whatever may have happened, he did not return.

At length, with patience exhausted, she climbed the highest ice-pile and gazed away to the north. The first glance brought forth a cry of dismay. A narrow lane of dark water, stretching from east to west, extended as far as eye could see in each direction. It lay not a quarter of a mile from the spot where she stood.

"He's across and can never recross to us!" she moaned in despair. "No creature could brave that undercurrent and live. And there is no other way."

Then, as the full terror of their situation flashed upon her, she sank down in a heap and buried her face in her hands.

They were two girls, ten miles from any land, on the bosom of a vast ice-floe, which was slowly but surely sweeping toward the unknown northern sea. They had no chart, no compass, no trail to follow, and no guide. To move would seem futile. Yet to remain where they were meant disaster.

As if to complete the tragedy of the whole situation, a snow-fog drifted down upon them. Blotting out the black ribbon of water and every ice-pile that was more than a stone's throw from them, it swept on to the

south with a silence that was more appalling than had been the grinding scream of the tidal-wave beneath the ice.

WHAT had happened to the young college boy had been this: he had hastened to the north in search of the trail. Rover, with nose close to the ice, had searched diligently for trace of the lost trail. For a long time his search had been unrewarded. But at last, with a joyous bark, he sprang away across an ice-pan.

The boy followed him far enough to make sure that he had truly found the trail, then, calling him back, turned to retrace his steps.

Great was his consternation when he discovered the cleavage in the floe. Hopefully, he had at first gone east along the channel in search of a possible passage. He found none. After racing on for a mile, he turned and retraced his steps to the point where he had first come upon open water. From there he hurried west along the channel. Another twenty minutes was wasted. No possible crossing-place could be found.

He then sat down to think. He thought first of his companions. That they were in a dire plight, he realized well. That they would be able to devise any plan by which they could find their way to any shore, he doubted; yet, as he thought of it, his own position seemed even more critical. The trail he had found would now be useless. He was north of the break in the floe. Land lay to the south of it. He had no way to cross. In such circumstances, the dog, with his keen sense of smell, and his compass, with its unerring finger, were equally useless.

"Nothing to do but hold on," he mumbled.

He sat down patiently to wait.

And, as he waited, the snow-fog settled down over all.

## CHAPTER X

### "WITHOUT COMPASS OR GUIDE"

IT was with a staggering sense of hopelessness that the two girls on the bosom of the arctic floe saw the snow-fog settle down upon them.

"It's likely to last for days, and by that time—" Marion's lips refused to frame the words that would express their condition when the snow-fog lifted.

"By that time—" echoed Lucile. "But now—we must do something. Surely, there is some way!"

"'Without compass or guide?'" Marion smiled at the impossibility of a solution.

Unconsciously, she had repeated the first line of an old song. Lucile said over the verse softly:

"Without compass or guide  
On the crest of the tide.  
Oh, light of the stars  
Pray pilot me home!"

Involuntarily her glance stole skyward. Instantly an exclamation escaped her lips: "Oh, Marion! We can see them! We can! We can!"

"What can we see?" asked Marion.

"The stars!"

It was true. The snow-fog, though spread over the vast surface of the ice, was shallow. The stars gleamed through it, as if there were no fog at all. Wildly their hearts beat now with hope.

"If we can locate the Big Dipper," said Lucile, whose astronomical research had been of a practical sort, "we can follow the line made by the two stars at the lower edge of the Dipper and find the north star. All we have to do then is to let the north star guide us home."

This was quickly done, and in a short while they had mapped out a course for themselves which would certainly come nearer bringing them to the desired haven than would the northward drift of the ice-floe.

"But Phi?" exclaimed Lucile.

Marion stood for a moment undecided. Should they leave this spot without him? She believed he would make a faithful attempt to rejoin them. What if they were gone when he came? Suddenly she laughed. "Rover!" she exclaimed. "He can follow our trail. If Phi comes, he will have only to follow us. He can travel faster than we shall. He may catch up with us."

So with many a backward glance at the gleaming north star, the two girls set their course south by east; a course which, in time, should bring them in the vicinity of the Diomed Islands.

In their minds, however, were many questions: Would further tide-cracks impede their progress? Would the snow-fog continue? If it did, would they ever be able to locate the two tiny islands which were, after all, mere rocky pillars jutting from a sea of ice?

PHI did not sit long on the ice-pile under the snow-fog. He was born for action. Something must be done. As he rushed back over the way by which he had come, something caught his eye.



An immense ice-pan had been up-ended by the press of the drift. It had toppled half over and lodged across the edge of a smaller cake. Now, like an ancient drawbridge, it hung suspended over the black moat of the salt-water channel.

The boy's quick eye had detected a very slight movement downward. As he remem-

For some time he lay there in deep thought. He was searching for a way out. After a while he opened his eyes. More from curiosity than hope, he squinted once more along the line. Then, with a wild shout, he sprang into the air. The natural drawbridge was falling. Its point had dropped out of line.

The shout died on his lips. His eyes had warned him that the channel of water was widening. If it widened too rapidly, if the drawbridge fell too slowly, or ceased to fall at all, hope would die.

Moment by moment he measured the two distances with his eye. Rover, sitting by his side, now and again peered up into his eyes as if to say, "What 's it all about?"

Now the drawbridge took a sudden drop of a foot. Hope rose. Then, again, it appeared wedged solidly in place. It did not move. The channel widened a foot, two feet, three. Hope seemed vain.

But now came a sudden tide tremor across the floe. With a crunching sound, the massive cake toppled and fell.

The boy was on his feet in an instant. The chasm was bridged. But the cake had broken in two. Could he make it?

Calling to his dog, he leaped upon the

slippery surface. An ever widening river of water flowed where the cake had split. With one wild bound, he cleared it. The dog followed. In another moment they were safe on the other side!

"That 's well over with," the boy sighed, patting the old dog on the head. "Now the question is, how can we find our friends?"

That, indeed, was a problem. They had covered considerable ground. To pick up their back trail seemed impossible.

An hour's search convinced him that it



"OH, MARION! WE CAN SEE THEM! WE CAN!"

bered it now, the cake had made a far more obtuse angle with the surface of the pool a half-hour before than it did now.

Was there hope in this? Hastily he arranged three bits of ice in one pile, then two in another. By dropping flat on the ice and squinting across these, he could just see the tip of the up-ended cake. If it were in motion, the tip would soon disappear.

Eagerly he strained his eyes for a few seconds. Then, in disgust, he closed his eyes. The cake did not seem to move.

could not be done. He sat down in a brown study. He could not go away and leave these girls to drift north and perish; yet further search seemed futile.

Just as he was about to despair, Rover began to bark in the distance. Following the sound, he came to where the dog was apparently barking at nothing. But as the boy approached, the dog shot away over the ice.

"A trail!" he muttered, following on.

The ice was hard and smooth. A soft skin "muckluck" left no mark. Even the hard toes of a white bear would not scratch it.

When the boy had followed for a half-hour, he thought of these things and paused to consider. What if he were following the meandering trail of a lumbering white bear? And if it happened to be a trail of a human being, was it his own trail, that of the girls, or of the bearded miner and his guide?

His compass would tell something. Studying his compass then, he walked forward slowly.

Fifteen minutes of this told him that this was no white bear's trail. It went too straight ahead for that. Neither could it be his own trail, for he would have come to a sudden turn before this. One thing more was certain—the person or persons who made this trail were headed due south by east.

After a few moments' reflection, he decided that there remained but one thing for him to do—to follow this trail.

"All right, old dog," he said, "let 's see where this ends and who 's there. Might be an Eskimo hunter who has wandered far on the ice-floe, for all I know; but he 'll end up somewhere, sometime."

DURING the greater part of this t'ime, Marion and Lucile, shaping their course by the stars, were traveling in the general direction of the Diomed Islands.

Suddenly, as she marched along ahead, Marion uttered a low exclamation, at the same time pointing to the mark of a skin-boot in the snow.

She did not say it, but she was at once convinced that it was worn by the same person whose footprint she had seen close to the cabin on the beach near the wreck. Had they come upon the trail of the bearded miner and his guide, or was this some other person? If they met on the ice-floe, what would happen, defenseless as they were? Even their dog was gone.

For a moment, consternation seized her; but the next instant found her calm. There

was nothing to do but go on, keeping the course they had chosen.

"Probably some Eskimo hunter out for white bear," she said to Lucile; "or, for that matter, it might have been made some time ago, on a spot of the ice-bound ocean's surface hundreds of miles from here."

And again they took up their march due south by east.

PHI had been plodding along after Rover for hours. Minute by minute the scent of the trail they followed grew fresher. He could tell this by the old dog's growing eagerness. At every ice-pile they rounded, he expected to catch sight of human figures. Would it be two men or two girls? He could not tell. Not a chance footprint in soft snow had he seen.

When he had fairly given up hope of overtaking them, as he speeded around a gigantic ice-pile, he came in sight at once of those he followed and of land.

So overjoyed was he, that, before determining their identity, he shouted cheerily, "Hey, there!"

The figure nearest him wheeled in his track. Then, with the fierce growl of a beast, sprang at the boy's throat.

So taken by surprise was Phi, that he was totally unprepared for the attack. He caught a vision of a pair of fiery eyes set in a mass of shaggy hair; the next instant he felt himself crashed to the hard surface of the ice.

The odds were all in favor of the man. Larger, stronger, older, with the advantage of the aggressor, he bade fair to finish his work quickly. The native guide had passed beyond the next ice-pile. Rover had followed.

But the boy's college days had not been for naught. He knew a trick or two. As if stunned by the fall, he relaxed and lay motionless. Seeing this, the man took time to plant his knees on the boy's chest before moving his hands toward the lad's throat.

The next instant, as if thrown by a spring-board, the man flew into the air. Phi was now on his feet. His one thought was of escape. Turning, he dashed around an ice-pile; then another and another. But fate was not with him. Just at the moment when he felt that he could elude his pursuer, his foot struck a crevice in the ice, and he went sprawling. Again the thing of terror was upon him.

But this time, there came tearing over the ice a new wild terror, and this one was his friend. Old Rover, silent and determined, sprang clean at the man's throat. The as-



sailant went down, striking out with hands and feet and roaring for mercy.

Phi dragged the dog away from him, and, pointing toward the islands which loomed in the distance, motioned the man to go.

"You 're some dog!" the boy laughed at the old leader; "well, now, I 'll say you are!"

The dog stood on his haunches and howled; howled until the distant cliffs of the islands sent back the echo.

Other audience he had than Phi. Marion and Lucile heard that howl, and redoubled their speed.

As they rounded some splinters of ice, Marion sprang forward.

"Look, Lucile! The blue envelop!"

It was none other. It lay there on the ice alone.

"That 's queer," said Lucile.

Marion still held the envelop in her hand, when they came upon Phi and Rover.

"Did—did you lose this?" she asked, without thinking.

"Why, yes," the boy smiled, "I believe I did, or you did, or something of the kind. Glad to see it. May I have it?"

His face took on a tense expression, as he took the letter from the envelop. He read with what appeared to be absorbing interest.

"Jove!" He said, "That 's—that 's all right! Where 'd you find it?"

Marion suddenly forgot that she had suspected him of having it all the time. "Back there on the ice," she smiled.

"That explains it. His nibs, your bearded friend, just now attacked me. Probably thought I was after that letter. In the fight he doubtless lost it from his pocket."

All at once Marion remembered the large skin-boot track by the cabin on the beach and the one on the ice-floe.

"Yes," she said, "that explains it. He stole it from my paint-box. It was he who threw our things about while searching for it."

"But it would n't do him any good," the boy's face took on a puzzled expression; "it 's written in Greek."

"Probably going across to find some one who could read it."

"Probably."

For a time they were silent.

"I—I guess I may as well tell you about it," said the boy. "It 's really no great mystery; no great story of the discovery of gold, or anything. Just the locating of a bit of whalebone.

"You see, my uncle came to the North with two thousand dollars. He stayed three years. By that time the money was gone and he had found no gold. That happens often, I 'm told. Then, one day, he came upon the carcass of an immense bow-head whale far north on the Alaskan shore. It had been washed ashore by a storm. No natives lived near. The bone of that whale was worth a fortune. He cut it out and buried it in the sand-dunes near the beach. So eager was he to make good at last, that he actually lived on the gristly flesh of that whale until the work was done. Then he went south in search of a gasoline schooner to bring the treasure away. It was worth four or five thousand dollars. But he had made himself sick. He was brought home from Nome delirious. From his ravings, his son, my cousin, gathered some notion of a treasure hid away in Alaska. The doctor said he would recover in time. His family was in need of money. I offered to come up here and find out what I could. His son was to write me any information he could obtain. We had written one another letters in Greek while in college. We decided to do it in this case, addressing one another as Phi Beta Chi.

"Apparently, my uncle had said too much in his delirium before he left Nome. This crooked old miner, our bearded friend, heard it, and later, somehow, got on my trail.

"You know the rest, except that this letter gives the location of the whalebone. In the spring I shall go after it."

"Then," murmured Marion, still a trifle mystified, "why were you in such a hurry to get across the straits?"

"That 's easy," he smiled; "there was a fair chance that the letter you had lost was not the most important one. The right one might still be waiting for me at the post-office. Then, too, my cousin might have written a duplicate. At any rate, I had to take the chance. It was all there was left to do."

"Shall we go now?" He smiled again. "All right, Rover; mush!"

"Brave old Rover!" murmured Marion. "For he is a white man's dog."

No further interruptions came to Phi's plans. In the middle of the next summer he might have been seen leaning over the rail of a southbound steamer. Beside him stood a girl. It was Marion. She was going "outside" to study art; he to deliver the treasure to its owner.

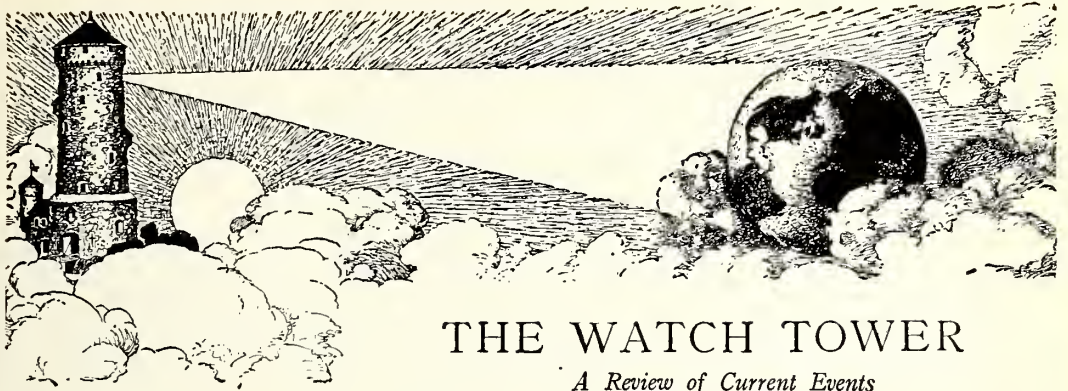

## THE WATCH TOWER

*A Review of Current Events*

By EDWARD N. TEALL

### CONGRESS REFUSES TO DESTROY THE NAVY

ON April 15, Congress passed, by a vote of 177 to 130, an amendment to the naval bill for 1923, increasing the number of enlisted men from 67,000, as at first provided for, to 86,000. President Harding had used his influence in favor of the amendment.

We do not believe that Congress and the President oppose each other for the fun of it, as some newspaper articles might lead a careless reader to think. We do believe that there are genuine differences of opinion, that sometimes party politics affect the views of both sides, and that frequently a test of power in which one must give way to the other is bound to occur.

We do believe that both Congress and the Chief Executive are trying faithfully to serve the country, and that, after they disagree on some matter of policy, the final settlement, taking both views into account, comes pretty close to embodying the best wisdom of the country. We think that in this instance the President was right and the "small navy" men in Congress were wrong; and we are sincerely glad that the vote went as it did. To represent it as a battle between the executive and the legislative branches of the government, in which the President was victorious and forced a reluctant Congress to accept his will is, in our view, silly and mischievous.

The vote was taken amid an excitement that showed how important it was. When the presiding officer called for ayes and noes, there were loud shouts on both sides, so nearly even in strength that no one would have dared to base a decision on the volume of the two roars, one for and one against the amendment. Then, as the members went

down the aisles to have their individual votes recorded, there was great confusion on the floor and in the gallery; and when the result was announced, the victors applauded long and loud. That vote in the House did not settle the matter conclusively, but a record vote a few days later proved that the fight for the larger navy had been won.

The naval treaty drawn by the Washington Conference established the 5-5-3 ratio for the navies of England, America, and Japan. That proportion was fixed, not accidentally or by mere whim, but as the result of the best judgment of naval experts and experts in international relations, after long study of the conditions most certain to keep peace in the Pacific. To turn the maximum allowed each country into a minimum is both natural and right. The navies are needed, and the strength decided upon for each, by the treaty makers, represents the safest footing for the powers concerned and for the peace of the world.

THE WATCH TOWER hopes it will never again have to fill its columns with articles about a war in which nations are sacrificing life and property to settle disputes or to defend other nations against one nation's mad endeavor to gain dominion. But THE WATCH TOWER also hopes, most earnestly, that it will never again see American men sent into a war forced upon this people, unprepared and suffering cruel losses while catching up with militaristic aggressors.

The United States Navy has a wonderful record of efficiency in service, and it has never been anything but a force for the maintenance of peace when there has been no war, and for the swiftest possible end to war when there has been one.

The great thing for us to-day is to keep



our manhood ready for the test when it comes. We do not need to support great forces of professional fighters, but we do need to have men ready to go into army and navy with the knowledge of military and naval science that will give them a chance for their lives. We specially need large reserves of officers.

### THE CONFERENCE AT GENOA

THE first great difference between the conference at Genoa in April and the Washing-

around the Pacific Ocean, the Genoa Conference concentrated upon strictly European matters.

A good many students of international affairs looked forward to the Genoa Conference not only without optimism, but with serious misgivings lest the gathering of delegates representing so many opposed interests might only exaggerate the conflict and result in an outburst of flame among the smoldering embers. The greatest credit must be given to Mr. Lloyd George, whose faith never wavered and whose energy never slackened. Except for his efforts, it is doubtful if the conference could have been held, or, being opened, could have made any progress, except toward a new war. Mr. Lloyd George has made his mistakes, but he has been a force all through these hard years for the encouragement of those who believe things can be straightened out.

From the first, interest settled upon the question, What will Russia do? Early in the sessions it looked as though the soviet delegates, surrounded by representatives of the hated capitalistic nations, were trying for just one thing—to get into their own hands as much of the capital as possible and go back home with a large loan.

Would the Soviet Government recognize the debts of the Czar's Government, and accept responsibility for their payment? Russia is Russia, and changes in government, even revolutionary changes, do not cancel old obligations. If the Russians of to-day refuse to accept the debts of Russia of yesterday, how could anybody lend money to Russia of to-day—when Russia of to-morrow might be unwilling to recognize them?

The Russians tried to trade these debts off against bills they proposed to present, covering losses sustained in putting down counter-revolutions. But it was not long before they began to give ground; it was made clear that the nations at the conference were talking business, not theories.



International Newsreel

DAVID LLOYD GEORGE AND HIS DAUGHTER MEGAN IN THE GARDEN OF THEIR VILLA AT GENOA

ton conference was that the Germans and the Russians were not represented at our meeting, and we were not represented at Genoa, while Germany and Russia were. And whereas the Washington Conference confined itself principally to questions having to do with international relations on and



A very important early development was the signature of a treaty between Germany and Russia. It provided for economic co-operation, and protected Russia against colonization. This was a most important piece of news, not only to the two nations involved, but to the rest of the world.

This may be the best of all possible

dous task of organizing the administrative system of the country. One corner of the triangle of trouble had been removed; any further difficulties would be between the north of Ireland and the south of Ireland, between Irishman and Irishman, not between Irishmen and British. If there was to be fighting, it would be civil war.



Wide World Photos

"FREE-STATERS" AND "REPUBLICANS" IN DUBLIN ADDRESSED BY MICHAEL COLLINS

worlds; it is not the best of all imaginable worlds. It has been going through a terrible test; and while there are reasons enough for being discouraged,—if you want to be discouraged!—there are also plenty of reasons to be hopeful, even quite confident, if that is your preference. It certainly is ours in *THE WATCH TOWER*. We do not think we are feeble-minded, either, when we declare that it looks to us as though excellent progress has been made in repairing, in less than four years, so much of the damage done in more than five years of devastating war.

Anyway, we 've gone more than four years without starting up a new war!

### THE STRUGGLE IN IRELAND

AFTER the British troops were withdrawn from Ireland, the world watched with interest and with hope mixed with misgiving to see how the Provisional Government of the Irish Free State would fare in its tremen-

A peace agreement was drawn up, beginning with this statement of great promise: "Peace is declared, the two Irish Governments agreeing to coöperate to restore order in the unsettled areas." And then rules were set forth to govern the action of the two parties to the agreement in such matters as complaints of violence. The interesting thing about this agreement was that it divided responsibilities and privileges between Catholics and Protestants.

The key to the Irish problem, after the British got out, was the success or failure of the Provisional Government in keeping the peace in the south. Mr. de Valera refused to accept the new government. He urged the young men to take Ireland for themselves and establish the republic in fact, as it had been cherished by them in name. Mr. Griffith and Mr. Collins worked valiantly to make the new government effective. The opposition to their efforts was bitter; there were attempts to murder Mr. Collins,



These facts are familiar to all; we recite them to help in getting at a clear idea of just what the "Irish situation" was this spring. Ireland's best friends deplored the possibility of a civil war, with one Irishman's hand raised against another. They had some sympathy for Mr. de Valera in his devotion to his "cause," but they could not see that its success could bring anything but woe to a country at last offered a chance to live at peace and enjoy working for its own prosperity. The treaty with England promised a happiness that they hated to see destroyed for any reason. They thought that Ireland had gained true freedom, and they could not see that Mr. de Valera was fighting for anything but a name.

On the whole, the spring of 1922 began with the chances for real peace in Ireland stronger than the likelihood of continuing war and suffering.

#### A LITTLE GIRL IN AFRICA

It is a pleasure to print, this month, a picture of little Miss Alice Hastings Bradley, one of the youngest explorers of whom we know. She is only six years old, but she has traveled in Africa.



Photo by Paul Thompson

THE YOUNGEST MEMBER OF THE AKELEY EXPEDITION

She went with the expedition commanded by Dr. Carl E. Akeley of the American Museum of Natural History. They went into the interior of Belgian Congo.

The pygmy tribes of that far-off land had never seen a white child, and the little American girl was an object of curiosity to them.

Miss Martha Miller, who went with the expedition, was one of the keenest hunters it had. She brought down big game with her rifle. She shot the only elephant brought down by the expedition.

American girls go everywhere and do everything, these days.

#### ANOTHER SCHOOL YEAR ENDS

EVERY few minutes, as it seems to the chronicler in *THE WATCH TOWER*, we come to the end of a school year and the pleasant duty of wishing the boys and girls of our large family a successful passage between the Scylla of spring fever and the Charybdis of examinations. Time flies, and the days and weeks slip past like things seen in a dream. When there is so much to do, how can any one ever complain because time goes slowly? And yet, you know, there are some folks who do!

Even though we get round to it earlier than others who make promotion-and-graduation-time addresses to Young America, we do not always find it easy to select subjects for our discourses. You see, people have been talking and writing for a good many centuries, and there is n't much to be said that has n't been said before! Still, if it's really worth saying once, it's worth saying twice; so, as we have often remarked in these columns—Let's go!

Success is a fruitful topic for end-of-the-school-year consideration. We happen to have seen, within the last few days, a statement about the proportion of those without the so-called higher education who attain success, in comparison with the proportion among those who go from grammar school to high school, and from high school to college. The comparison is very much in favor of the folks who spend the longer time in getting an education.

But a good deal depends upon what you call success. Education means more than a diploma, and success means more than so many dollars in the bank. Educated men and women are more apt to hold high executive positions than those who have not trained their minds for constructive think-

ing. They are likely to earn more money. But they are not the only successful persons—they are not even, necessarily, the most successful persons.

A man who has little "book learning" may possess a strength of character that makes him master of himself, a good head of a family, a useful citizen, and a factor in the life of his community; he may be a happy and successful man. Success must be measured in terms of the individual's capacity; what is success for one, would be a small achievement for another.

But there is this to be remembered, that education expands our horizon, enlarges our powers and gives direction to our energies, making them more effective. The person of great ability can make better use of his natural powers if they are thus trained; a person of less ability can go farther than his natural equipment promises.

Imagine what it would mean to America if an item like this could go into our newspapers: "The Commissioner of Education reports that every student in the public and private schools of the country and in the colleges has finished this year's work with marks that indicate that no one has done less than his best." You 'll never see that till you become a subscriber to the "Utopian Daily News"! But it represents the ideal toward which all school work strives.

Come to think of it, this seems more like a September talk than one for June; but don't we have "commencement" at the end of the year and the course? The close of each school year is the beginning of a new period in *The Pupil's Progress*.

The most important of "current events" in June are the school commencements. They are a step on the road to success for thousands and thousands of young Americans, whose success in life will help make success and true prosperity for this country.

#### THROUGH THE WATCH TOWER'S TELESCOPE

THE magic word in 1922 is "radio." Its amazing progress makes it necessary to establish rules and regulations for its use. One problem considered at the Radio Conference at Paris in April was whether an international code could be drawn up, so that messages could be picked up and understood, when desired, in different countries. No attempt at a world language has had much success, as yet.

WHEREVER we turned the telescope, in the spring days, we saw excitement over robberies and hold-ups. There was widespread lawlessness, and people were wondering why the police seemed so powerless to protect those who went quietly about their business. Cases piled up faster than the courts could try them. It was a strange thing to see, in our America.

A REVOLUTION in Honduras began in April. Dispatches from San Salvador reported that there were serious disturbances along the Nicaraguan frontier. Serious disturbances are a regular part of normal life in Central America.

AT Easter time, the former German crown prince declared his belief that Germany would be "resurrected." "Whoever places his world citizenship above his Germanism had best emigrate," he said. Hindenburg urged the Germans to stand together and "go up the hill again." Ludendorff said, "The German nation now unites against its foes—or it dies." If these gentlemen were thinking of a restoration of the Hohenzollern monarchy, they will be disappointed. But we trust there are thousands of Germans who share their belief in the need of courage and hard work—but for the advancement of the German Republic and the rebuilding of Germany's honor.

CHINA has many tree nurseries where they are growing trees to take the place of forests that have been cut down. Reforestation is one of China's great needs. A few years of the present program will do much to improve conditions in China.

DID you read about the huge gyro-stabilizer built for a Shipping Board steamer? It works like the gyroscope top. It makes 880 turns a minute, and they say it will keep going eighteen hours after the power is shut off. The machine weighs 120 tons. It takes the roll out of a ship, but does not affect the pitching motion. Oddly enough, it will be useful not only in steadying a ship at sea, but in loosening a vessel grounded in shoal water. What will happen when some one invents a gyroscope powerful enough to take the roll out of the earth as she sails through space? And, since we are asking questions, what would have happened if, in those far-away days in old Syracuse, Archimedes had found a fulcrum for his lever?



# NATURE AND SCIENCE FOR YOUNG FOLK

## GUIDING AIR-CRAFT INTO PORT AT NIGHT AND IN FOGGY WEATHER

DURING the war, Lieutenant W. A. Loth, of the French navy, invented a system of guiding ships into port in cases where the channel was beset either with mines or with natural obstacles. His method consisted, in brief, of laying an electric cable along the channel to be followed, and having it extend into the sea to any necessary distance from the shore. This ingenious device was described in *ST. NICHOLAS* for December, 1920, by Mr. A. Russell Bond, but since some of our young readers may have missed his account of it, we will repeat here the essential features.

The electrical vibrations coming from the cable are taken up by two receiving-coils,

frequency, and it was found convenient to send a current of a frequency corresponding to that of the vibrations by which musical sounds are diffused. This is called by electricians a current of musical frequency, just as they speak of currents of voice frequency with respect to the telephone.

The faint signals thus induced in the pancake coils are intensified about four hundred times by amplifiers. As the receiving-coils cross the magnetic waves of the field surrounding the cable, electric currents are set up in them, which flow upward to the telephone on the bridge of the ship. By means of a switch, the operator connects the telephone receiver first with one pancake coil and then with the other, so that he can compare the strength of

the two signals, i. e., their loudness. When they are equally loud, he knows that the ship is immediately above the cable, and is, therefore, making a bee-line to port. But when the signals from one coil are louder than those from the other, the ship is veering to one side and must be brought back to a straight course. Since these signals can be heard even at distances of two and three thousand meters from the cable, the latter forms an excellent guide. One very useful pilot-cable was located at Brest—the French port

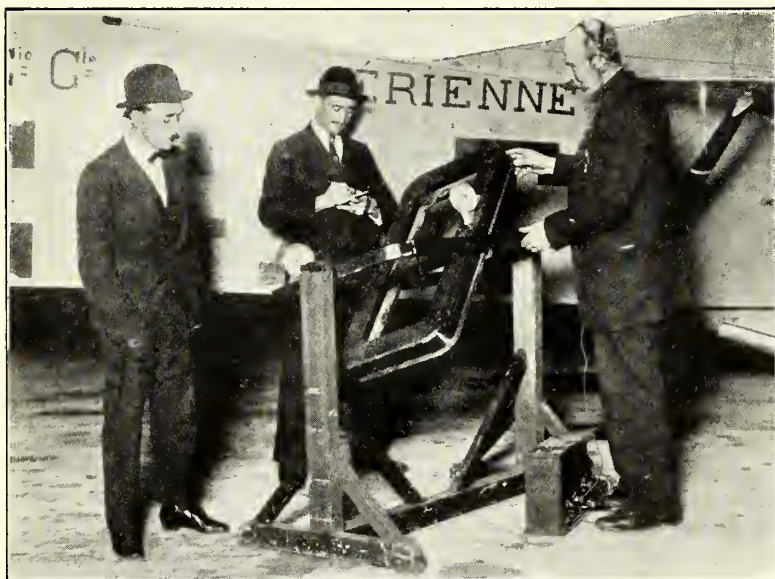

APPARATUS FOR MEASURING THE MAGNETIC FIELDS

one on each side of the ship—these are flat spirals four feet in diameter called “pancake” coils. The signals are transmitted from the cable to these coils by what is known as induction. This is based on the principle that when an alternating current passes through a wire it is surrounded by a field of magnetic waves, and these waves induce an alternating current in any wire that crosses their path. As you know, such currents vary in

where our American soldiers disembarked and embarked by the hundred thousand during the war and after the armistice. This cable was eighty kilometers in length, extending to the entrance of the English Channel. Another important pilot-cable was that in the Ambrose Channel, which was described in Mr. Bond's article.

A year or so ago, the French Government requested Lieutenant Loth to continue his

experiments, with the object of adapting this method to the guiding of aircraft safely into their aërodromes, even at night or in foggy weather. This problem presented special difficulties because of the interference with the magnetic field surrounding the cable by the magnetic fields surrounding the ignition magnetos upon aëroplanes. After some months of study, the inventor announced to the French Academy of Sciences, in Paris, his successful solution of the matter in the following words:

"The results obtained which I have had the honor to present to the Academy permit me to regard the problem as being solved. The utilization of this new method will, in the opinion of experts, be of the greatest service to aërial navigation by enabling it to continue uninterrupted from one aërodrome to another at night and in foggy weather, under circumstances when hitherto flying has been impracticable."

While we can not here discuss the peculiar technical difficulties which Lieutenant Loth was obliged to surmount, we may say that, in his system, an alternating current of two or three amperes, having a given frequency, is sent along a wire connecting the aërodromes. The aëroplane carries a small apparatus weighing only about nine pounds, which is "tuned up" exactly to this frequency, i. e., brought into harmony with it just as a piano-tuner brings the C string of a piano into harmony with the pitch of a C tuning-fork. This apparatus operates a musical instrument, which gives a higher or a lower note according to the distance of the aircraft from the wire. The radius of action is very considerable, the sounds produced being distinctly perceptible even at a height of 3000 meters (about 10,000 feet).

We must not forget that the air-pilot must think of his problem in terms of three dimensions instead of two; which is merely another way of saying that he must consider his path in terms not merely of length and breadth, but in those of altitude as well. He, therefore, needs three receiving-coils instead of two. These coils are attached to

the aëroplane, while the pilot hears the signals through ear-pieces, called "listeners," in his helmet. When the machine is flying directly above or parallel to the cable, a strong signal is transmitted to the pilot through the center coil, and this continues as

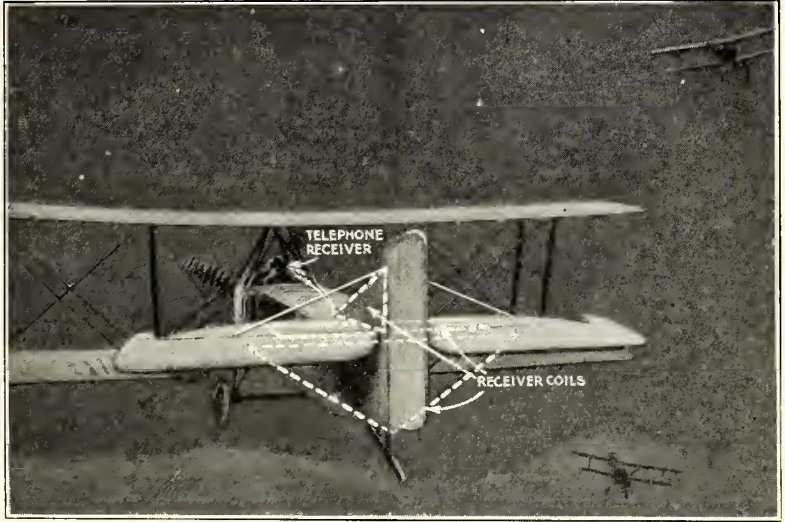

Courtesy of "Popular Science Monthly"

POSITION OF THE RECEIVER COILS ON THE AIRPLANE TAIL, INDICATED BY DOTTED LINES

long as the cable is being "followed." The other coils indicate when the machine is to right or left of the cable, and enable the pilot to "pick up" the installation. The signals can be heard not only at a height of 10,000 feet, as we said before, but for a mile and a half to the right or left. The reason the sound range is so much greater in the air than on the ocean is because in the former there is no loss of energy such as is involved in the production of currents in sea-water.

When the aviator wishes to make a landing, he manipulates the receiving-coils in a special manner, which enables him to judge of the correct angle of descent.

M. TEVIS.

#### MERULA

MERULA is a rather stylish, fine-appearing robin less than twelve months old, who was brought to my bird hospital late last summer, suffering from a fractured wing. The scantiness of her feathered apparel and the brevity of her tail at once placed her in the just-out-of-the-fledgling list, which was confirmed by her foolish manners. In all likelihood she was a member of the second brood of her industrious mother.

Her nervousness and disposition to panic,



with the necessary treatment of her broken wing, rendered confinement irksome for a time; but as she came to realize that an abundance of food ever awaited the calls of



THE HOSPITAL FOR WOUNDED WILD BIRDS

hunger, the home feeling took complete possession of her and she quickly adjusted herself to the new conditions of her life.

For social reasons, two messmates were given her, a Bohemian waxwing and a house finch who had enjoyed the benefits of the hospital for several months during the mending of fractured wings.



MERULA

Merula and the waxwing were as unlike in temperament as it was possible for two birds to be. Merula was nervous and unstable, ever ready to develop a panic whenever any unusual thing occurred. The waxwing was calm and sedate as a statue, and while on his perch reminded one of a sentinel standing guard. Nothing less than an ear-splitting racket would cause him to become excited or frightened.

He and Merula furnished our home with constant entertainment in the unique game of bluff they constantly engaged in. The make-believe battle-ground was measured by the upper perch of the cage they occupied. The bird first gaining foothold on the perch would challenge the other comer to mortal combat. If it was Merula, she would make a dash at Waxy, snapping her long sharp beak in most vicious manner, and would declare in most vociferous language, according to my interpretation of it, "If you do not get off this perch, I will peck out your eyes!"

To this fusilade of dire threats, Waxy would unbend from his statuesque attitude and advance upon his scolding companion with wide-open mouth exclaiming, "You drop off this roost mighty quick or I'll swallow you whole!" And then, having played their parts, they would quietly drop down to the feeding-dish and feast together in the most friendly manner. Then by and by, when they felt the need of healthy exercise, they would repeat the grotesque mimic warfare. Despite their frequent indulgence every day in this seeming belligerency, when eventide came they snuggled up close to each other, with their meek friend, the house finch, beside them, and spent the night in peaceful sleep.

The generous supply of life-building food hastened Merula's physical development, and one morning in midwinter, when her ear caught the tea-kettle's vapory song, she be-



MERULA'S ADOPTED CHILDREN, BERRY AND CHERRY

gan to awaken to the fact that she possessed music-producing organs, and surprised the household with a faltering note of a robin's song. The awakening of this song impulse

brought great delight to the would-be musician and caused her to spend the greater part of each day in painstaking experiment and practice, for the songs the father had sung to the nestful of brothers and sisters was so far back in the past, when she was a foolish baby, that she could not recall a single measure of it, and so was compelled to improvise her own song. The cheeriness of this melody dissipated the dreariness of many a winter hour for herself and those about her. Waxy was greatly impressed with Merula's wonderful accomplishments as a songster and tried to rise to the same heights, but failed dismally, for, although equipped with a very perfect set of vocal organs, he was able to produce only a few soft, whispering, whistling notes, scarcely audible and bearing no comparison to the enthusiastic, ringing notes Merula poured out so gleefully.

The coming of warmer days and the return of her kindred from the southland aroused Merula to restless activity, her songs becoming more voluminous, and bearing a more subtle meaning. All about her prison home sounded the anxious calls of parent birds and the cry of hungry birdlings; and presently the children, cooperating with me in the work of affording care and protection to unfortunate wild birds, began bringing to the "bird orphanage" numbers of foolish, almost featherless, baby birds, largely robins, to be fed and protected.

One morning while acting as foster-father to two orphaned baby robins by cramming earthworms down their yellow throats, I noticed that Merula had become inordinately excited, and the thought flashed through my brain, "What would you do if these bantlings were placed beside you?" The answer came like a flash of lightning as I put the waifs in the cage with her, for, without a moment's hesitation for an introduction to the strangers, the excited little creature, with a burst of motherly enthusiasm, snatched up a worm and thrust it down the capacious throat of the nearest one, and, turning around, in like manner placed the seal of adoption upon the other baby. From that hour, no mother bird ever displayed greater interest and loyalty in the care of her young than did this youthful foster-mother. So great was her zeal in behalf of the little ones, and so hearty the acceptance of the new arrangement by them, that she seemed to lose sight of her own physical needs and almost starved herself in satisfying the demands of the children. W. W. ARNOLD.

### A BOY'S ELECTRICAL DEVICE DRAWS FISH-WORMS FROM THE SOIL

PICKING fish-worms from the ground by means of electricity is one of the diversions of a boy inventor at Kennewick, Washington—Joe Siegfried by name. Joe has rigged up



A LABOR-SAVING DEVICE FOR THE FISHERMAN

a simple apparatus consisting of a telephone magneto that delivers current at 80 to 90 volts. This magneto is connected to two heavy wires or electrodes set in the ground six or eight inches deep and fifteen to eighteen inches apart. When the magneto is operated, the current flows between the electrodes, and any worms that are in the vicinity receive a new sensation that causes them to hurry to the surface at full speed. Joe has counted as many as fifteen worms coming out of the ground at one time. He has had inquiries as to the charge for worms if bought by the gallon, but his school work keeps him too busy and he only uses his apparatus for furnishing fish-bait for his friends. GEORGE F. PAUL.



# FOR VERY LITTLE FOLK

## AN ADVENTURE

By H. C. SOUTHWICK

As I was walking about the town  
I met a very spec-tac-u-lar clown;  
He was dressed in velvet with purple shoes,  
And he looked as sad as a case of blues.  
Said I, "Oh, tell me, what is the matter?"  
And he answered back, "I wish I were fatter."

"You see I am quite so awfully thin  
That people call me a human pin.  
I know I wear the grandest clothes,  
But then, I long for a Grecian nose;  
And one of my arms is out of shape,  
And alas! my head is as soft as a grape!"

Said I to the clown: "How can this be?  
You look all right, it seems to me.  
I think the reason you have the blues  
Is due to your very fan-tas-tic shoes."  
So he threw his shoes right into the sea,  
And now he's as happy as he can be.

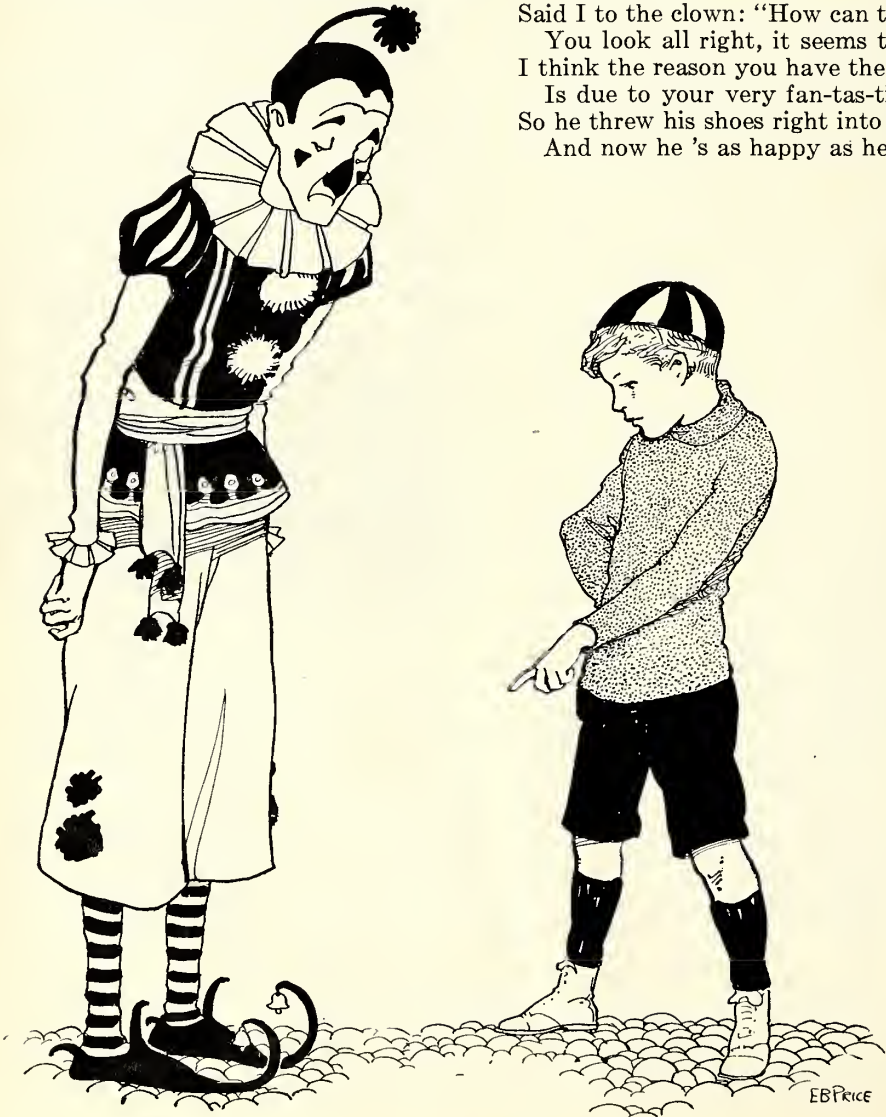



## The DRYDISH DRAGON

By EDITH BALLINGER PRICE



EDITH B. PRICE

I

WHEN I am drying dishes  
I pretend with all my might  
That I 'm a dreadful dragon  
With a "f'rocious appetite."

II

I pretend the yellow mixing-bowl  
(Turned upside down to drain)  
Is a shiny yellow custard  
That he eats with might and main.

III

And as for all the knives and forks—  
Why, really, very soon  
The dragon 's made them disappear,  
Down to the littlest spoon.

IV

Before we know it, all the shelves  
Are full of nice clean things;  
And the drydish dragon goes to sleep  
Under tea-towel wings!



## THE RED BALLOON

By  
EDITH BALLINGER PRICE

I WONDER where my red b'loon  
went  
When I let go the string?  
It flew right up 'n' up 'n' UP,  
As fast as anything!  
I think it went up in the clouds  
Where all the angels are,  
An' p'raps one of them caught it  
An' turned it to a star!



# ST. NICHOLAS LEAGUE

ST. NICHOLAS LEAGUE members have a great faculty for "hitting the nail on the head." They can take almost any subject and offer apt and ingenious contributions to fit the title.

The drawings this month, for instance, admirably illustrate the subject, "Waiting." The LEAGUE is developing a group of clever artists, and some show a talent for picturing current events that may make them successful cartoonists.

The photographs are excellent. Page 889 is a fine collection of out-of-door views, and those on other pages are equally good. Not so many years ago the title "A Familiar Scene" printed below the picture of an airplane would have been anything but correct; but these "birds" are a common variety now, and doubtless many of our LEAGUE members have enjoyed a flight.

There is a June-like flavor to the verse with its "green meadows," "cloud pictures," and "fields sparkling with the dew."

The subject for the prose contributions, "An Every-day Hero," brought an unusually large number of interesting articles covering in range almost every kind of unsung hero, but there was no better summary of the subject than that presented by one of our honor members, and we take pleasure in publishing it along with our introduction.

## AN EVERY-DAY HERO

BY ELIZABETH EVANS HUGHES (AGE 14)

(Honor Member)

THERE are many plain, every-day heroes in this world who are not known in that capacity at all,

but go about their daily business doing good so quietly and unassumingly that nobody ever thinks of recognizing in them the qualities that go to make a real hero. We are proud when we think of the well-known historical heroes this country has produced—generals, statesmen, scholars, inventors, orators, discoverers, and scores of others, whose names will be handed down from generation to generation as men who helped form the history of the world.

But who will be apt to remember, after they are gone, the thousands of every-day heroes who are quietly sacrificing their lives to make this world a better place to live in? The missionaries who go to distant countries, where danger and disease lurk, to preach Christianity and give medical aid to the sick, soldiers giving their lives for their country, Salvationists devoting their lives to the poor, captains who go down with their ships, cheerful, bedridden cripples, light-hearted tuberculosis victims, firemen who die of burns received while saving others, boys drowned while rescuing drowning chums, policemen shot attempting to catch burglars—all such instances, plus scores of others left unmentioned, make us realize how many of the ordinary, simple people are doing or have done heroic deeds in their lives. No monuments will be raised to their memory, no stories will be written about them, yet in their small, unassuming way, they have contributed, and are contributing daily, toward the good of this world. So let us try to join the army of every-day heroes by devoting our lives to doing something worth while.

## PRIZE COMPETITION No. 267

(In making awards contributors' ages are considered)

**PROSE.** Gold Badge, **Tom Avent** (age 16), Virginia. Silver Badges, **Mary Hoyt Stoddard** (age 15), Illinois; **Ena Louise Hourwich** (age 15), New Jersey; **Paul Francis Gleeson** (age 11), Rhode Island; **Helena M. Glenn** (age 12), Massachusetts.

**VERSE.** Gold Badges, **Helen Louise MacLeod** (age 13), District of Columbia; **Amy Armitage** (age 14), New York. Silver Badges, **Muriel Doe** (age 13), Maine; **Mary H. Wilde** (age 16), New Jersey; **Carolyn E. Asplund** (age 15), New Mexico; **Elinor Cobb** (age 12), New York.

**DRAWINGS.** Silver Badges, **Alice J. Feldman** (age 14), Colorado; **Norman Hallock** (age 14), Connecticut; **Helen Jean Snyder** (age 16), California; **Hope Nelson** (age 13), New Jersey; **J. Henderson Barr** (age 13), Michigan.—April Silver Badge winner, **Marion E. Lumb**.

**PHOTOGRAPHS.** Gold Badge, **Leonard Bruml** (age 17), California. Silver Badges, **Katherine W. Voegelin** (age 14), Maryland; **Rachel Hartzell** (age 14), Ohio; **Jean Macwatty** (age 14), New Jersey; **L. O. Field** (age 15), Wisconsin.

**PUZZLE-MAKING.** Gold Badge, **Charles Eugene Smith** (age 14), Vermont.

**PUZZLE ANSWERS.** Gold Badge, **Miriam J. Stewart** (age 17), New York. Silver Badge, **Elizabeth Elich** (age 13), Illinois.



BY JEAN MACWATTY, AGE 14. (SILVER BADGE)



BY L. O. FIELD, AGE 15. (SILVER BADGE)

## "A FAMILIAR SCENE"

## IN MEADOWS GREEN

BY MURIEL DOE (AGE 13)

*(Silver Badge)*

IN the green Kentucky meadows, where the blooded racers run,  
Where the world is still and happy underneath the southern sun;  
Where the trees are all in blossom far along the white highway,  
And the birds are singing sweetly through the long, hot, summer day—

You can hear the bees a-humming as they search in ev'ry flower;  
And you dream and feel so lazy, and you never know the hour,  
And you see the meadows hazy-like and the brook that 's singing low,  
And the breeze is fanning softly and your thoughts are drifting slow.

Then you wonder if 't was just by luck God placed Kentucky here,  
Underneath the skies of Dixie where you 'd feel no sorrow near—  
Where the moon could shine down on it and would sail on clear and bright,  
Thinking, if the Maker fixed it, He knew how to do it right.

And you see the old plantation and you catch the darkey song,  
And you find yourself a-dreaming as you watch the meadows long,  
Where they slope down from the mountains rising purple in the west,  
And you know that Dixie's meadows are the happiest and best.

## AN EVERY-DAY HERO

BY ESTHER LAUGHTON (AGE 14)

*(Honor Member)*

My every-day hero is one I really see every day. He looks exactly as a hero should look, a big gray-haired man in a khaki suit with a wonderful smile. With him always is Handsome Comrade. He and Handsome Comrade go about through the streets in our neighborhood, and the large houses and valuable property are kept safe by their presence. Perhaps you may guess that my every-day hero is a mounted policeman. Handsome Comrade is his horse, a splendid chestnut animal, beautiful and spirited as the horse of the Colleoni statue that stands in one of our Newark squares, and that is known as the finest equestrian statue in the world.

He is twenty years old, but good care, and pride in his master, have kept him strong and active. He has won many medals, and his master pats his neck when he tells how Handsome Comrade can step high and show off before the judges.

My every-day hero is very modest and courteous, but Handsome Comrade, though an aristocrat, is very forward in his manners, especially with the ladies. If his master stops to speak to one of the neighbors a moment, Handsome Comrade begins to paw and act impatient. If not noticed, he steps right on the sidewalk and goes after the lady with his mouth open. A stranger would be alarmed. But his master and the lady

laugh. He is saying: "Quick, quick please; give me that nice sugar-lump you have in your pocket! How I long for a bit of sweet! Quick, quick, please!"

He gets his sugar, and he gets also many a nice apple tossed from windows by his friends.

Every one is proud of Handsome Comrade and his master, and they ride about as if they knew it and enjoyed their work.

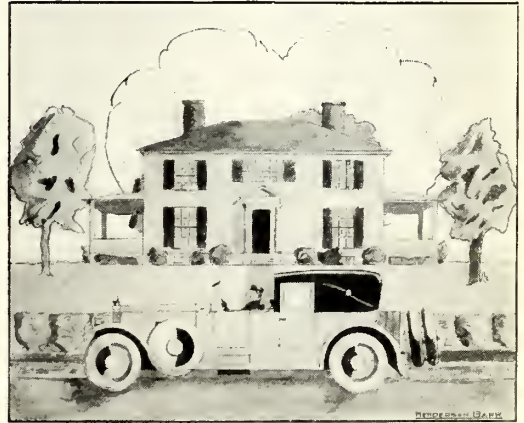

"WAITING." BY J. HENDERSON BARR, AGE 13. (SILVER BADGE)

## AN EVERY-DAY HERO

BY MARY HOYT STODDARD (AGE 15)

*(Silver Badge)*

MANY people only think of a hero as an illustrious, well-known personage whom every one honors in almost every conceivable way.

There is one hero, however, an every-day hero, a great public benefactor, who is rarely honored or given even slight consideration. He is taken simply as a matter of course, as a perfect automatic machine, which is expected to do its work every day at the same time in the same way, with little, if any, human feeling. He is often compelled to do his work under adverse conditions, such as rain, sleet, snow, cold, heat, and many other unpleasant things. He must travel muddy roads, steep, slippery hills, and cross streams unprovided with good bridges, all of which things try not only his own, but his faithful horse's, strength; for in some places automobiles are impossibilities. He may have a cozy cab; but must not one side be open so that he may put the mail in the often inconveniently placed boxes? Some one has left a dime in a box with a note which may read, "Please leave three two-cent stamps." Some one else wants a money-order. Imagine the man whose fingers are numb with cold trying to make change and write applications.

It is true that all the days are not so unpleasant, and sometimes, in very good weather, the hero may drive his automobile, if he happens to own one; but anyway, who enjoys the tiring, continuous riding, and who desires such a position? His salary is barely enough to pay current expenses, and as for pleasures and amusements, what R. F. D. man ever had many during his service?

Honor with your whole heart and voice the rural mail-carrier—a true, every-day hero!





"WAITING." BY HOPE NELSON, AGE 13. (SILVER BADGE)

### IN MEADOWS GREEN

BY HELEN LOUISE MACLEOD (AGE 13)

(Gold Badge. Silver Badge won July, 1921)

THE leaves of the trees are the keys of an organ,  
An organ the wind plays;  
And the creatures that live in the wind  
Give all their innermost thoughts and emotions  
Into the care of the leaves of the forest.  
The breezes betray them at every faint murmur.

The voice of the meadow is soft and low:  
"I am contentment; here dwelleth peace;  
Here the sun doth shine with his golden rays  
All through the dreamy summer days."

In the azure sea of the azure sky  
Is a cloud ship with wind-blown sails;  
And the hillside flowers dreamily  
Lift up their drowsy heads to view its passing.

I hear a voice that has no name,  
Sweet and soft and low;  
It tells of the things that happened here  
In a strange age long ago.  
I bow my head and ask if the cloud ship reaches  
shore,  
But my heart within me weeps, that these things  
are no more.

The cloud ships all at anchor lie, their sails aflame  
with roseate glow,  
Waiting until the glorious sun shall plunge into  
the depths below.  
And Luna from her silver palace, all unseen to  
mortal eyes,  
Doth rise; and from her sparkling chalice, floweth  
the glory of the skies.

### AN EVERY-DAY HERO

BY TOM AVENT (AGE 16—AND TOTALLY BLIND)

(Gold Badge. Silver Badge won February, 1922)

ALL of us can be every-day heroes. There are many of us who think that to be a hero is to do some very brave act in war. Of course, a man who does a brave act is a hero. All of us can be heroes; if we are thrown into bad company and are strong enough not to follow the crowd, then we are heroes.

There are many little things which we do that

are not remembered by our fellow-men which make us heroes of our time.

I heard in a newspaper the other day, where a mother left her house for a few minutes, to go to the spring. While she was gone, the house caught fire. She had left there her three children. The oldest was five years old, the next one two, and the baby six months old. The five-year-old child carried the youngest one out-of-doors and got her out of the way of the fire. She then wondered how she could get the next one out, for she could not lift her. She had the presence of mind to put the two-year-old child on a pillow and dragged her out of the way. After a while the mother came back. The house had burned down, but her children were all saved. We can imagine just how glad this mother was that all of her children were saved.

I suppose when the two younger children grow up, they will be told how their sister saved their lives, and they will never forget the brave act as long as they live.

I think that any one who does all he can for his country, state, community, and home is an every-day hero and will receive his reward.

### IN A MEADOW GREEN

BY MARY H. WILDE (AGE 16)

(Silver Badge)

IN a beautiful garden by a wall,  
There grew a rose sedate and tall;  
Over the wall in a meadow green,  
A little cowslip could be seen;  
High in the air in summer sky,  
A happy lark went floating by.  
The rose to the lark looked up and cried,  
"Oh, come to earth, stay by my side!"  
The little cowslip saw him, too,  
And whispered gently, "I love you."  
The rose looked down on the cowslip sweet,  
"Think you with the lark you 'll ever meet?"  
He never would look at a weed like you;  
From *my* petals only he 'll drink the dew."  
Just then the lark came floating by,  
The flowers called and reached up high.  
Over the garden, past them all,  
He flew past the rose and over the wall.  
At last, in the meadows did he stop;  
At last, near the cowslip did he drop.  
The rose entreaties he did not hear,  
But whispered, "Cowslip, I love you dear."  
Just then a breeze came frisking by,  
Which scattered the rose's petals high.

### AN EVERY-DAY HERO

BY LESLIE FRIEND (AGE 9)

THERE was once a poor boy, the son of a candle merchant. He had to work hard for a living, although he wanted to read books and to learn all that he could.

He never gave up trying to learn, and he used to stand by the book-stores by the hour, and read any books he could find.

When he grew to be a man, he watched the lightning, and he found a way to catch it, and coax it to make electricity.

He made a plan for peace between the Colonies; and after the Revolutionary War was over, he made peace between England and this country.

He was an every-day hero, and his name was Benjamin Franklin.



BY HAZEL SELIGMAN, AGE 13

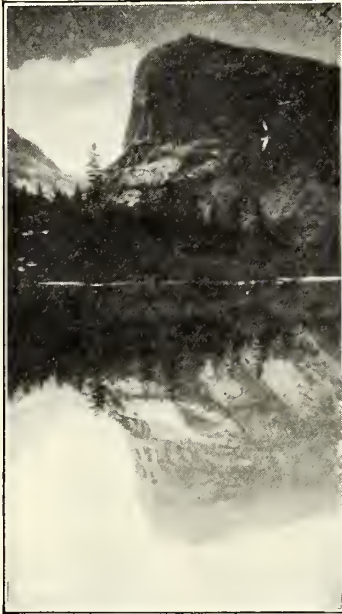

BY LEONARD BRUML, AGE 17. (GOLD BADGE.  
SILVER BADGE WON JANUARY, 1922)



BY EDGAR S. AUCHINCLOSS, AGE 12



BY ELLAN A. SCANLAND, AGE 13



BY MARSHALL MURDOCH, AGE 11

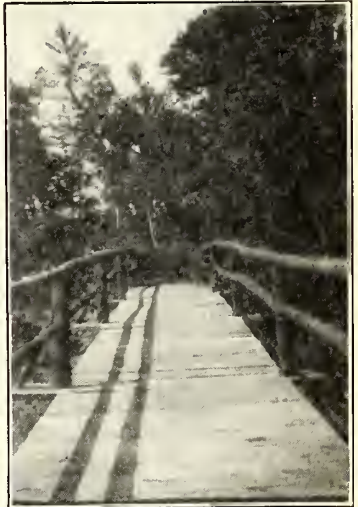

BY DOROTHY ROSE, AGE 13



BY RACHEL HARTZELL, AGE 14. (SILVER BADGE)



BY WINONA FULLER, AGE 17

"A FAMILIAR SCENE"



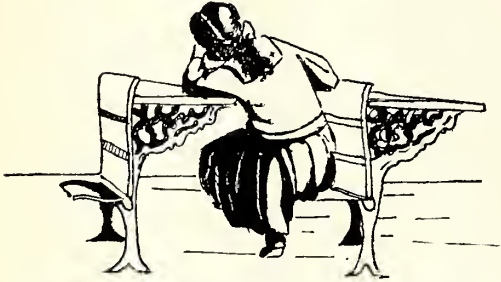

"WAITING." BY HELEN JEAN SNYDER, AGE 16. (SILVER BADGE)

"AN EVERY-DAY HERO"

BY ENA LOUISE HOURWICH (AGE 15)  
(Silver Badge)

ST. NICHOLAS had been out of the mail-bag only a few hours, but already Bud and Sis had begun their LEAGUE contributions. Sis placidly drew, at one end of the table. At the other, Bud desperately chewed his pencil. Suddenly he yelled, "I've got it!" and wrote as if his life depended upon finishing the story in five minutes.

After some moments, he stopped writing, and getting up, he looked at his sister's drawing.

"Pretty good, Sis."

"What've you written, Bud?"

"Oh, nothing—well, if you insist—'An Every-day Hero.' My hero is tall and strong, as a hero should be. But, unlike other heroes, few know his name. He is jovial, kind, and gentle. Every day, rain or shine, you will find him at his post. That is why he is an "every-day" hero. In his hands are the lives of many people, but he is always calm and unexcited, as if he were just taking in the view. You can hear his hearty voice at any time. "There you are, Bessie. I hope the baby'll be better soon," depositing a big doll-carriage and a tiny girl safely on the curb. Now he is carefully escorting an old woman to the sidewalk, then answering a bewildered stranger's question. And so it goes. Most likely you, too, know him, or some one just like him. Can you guess who my every-day hero is?"

"I know who he is," cried Sister. "It's Mr.—oh, what is his name?—the traffic-policeman down near the school!"



BY KATHERINE W. VOEGELIN, AGE 14. (SILVER BADGE)

AN EVERY-DAY HERO

BY ISABEL BURTIS (AGE 15)

JOHNNY threw his book down disgustedly. "There it is again!" he said; "all about heroes and such! Why can't I be a hero? If only I had been old enough to go to war, then I'd be one; or if I was a fireman, then I'd win lots of medals, rescuing babies from burning buildings. But what's the use! little boys can't win medals."

"Oh, can't they?" said Grandma, who sat near by, knitting on the same kind of sock that grandmas generally knit, "Can't little boys be heroes? Don't your heroes in books always obey and never complain? I thought so. Well, I think a little boy who does these things will be a hero."

Johnny went downstairs, thinking of what his grandmother said. In the kitchen stood the empty wood-basket. Cook was over by the stove. Johnny started to sneak out the back way, so he would not have to get the wood. Suddenly he remembered what his grandmother had said, "Heroes always obey." Well, had n't Father said always to fill the wood-box? Johnny laughed and went out with the basket.

All day long he practised being the hero; but at night the hardest trial came. Father and Mother were going to the show. Either John or his sister Mary would have to stay home with Grandma, Father insisted. It was not till Johnny had had a hard battle with himself that he let Mary go. But he had a very good time at home with Grandma, and when he went to bed he said, "Grandma, it's awful hard to be a hero, but it feels awful nice to be one."

IN MEADOWS GREEN

BY MARY WALLE (AGE 13)

In meadows green I love to lie  
And gaze up at the bright blue sky,  
And watch cloud-pictures passing by.

There is a castle far up there,  
All made of clouds, with pennons fair  
Fluttering and waving in the air.

Or on the waves of deep sea-green  
A fairy boat a-sail is seen,  
With silken sails of wond'rous sheen.

Oh, many hours of joy I glean  
From the cloud-pictures that are seen  
Whene'er I lie in meadows green.



BY SUSAN HAMMOND, AGE 15

## IN MEADOWS GREEN—NEW MEXICO

BY CAROLYN E. ASPLUND (AGE 15)

*(Silver Badge)*

ALFALFA in the meadow-lands grows green and tall;

The wild rose clammers o'er the low stone wall.  
One solitary Indian wends his way  
Home, ere the drowsy closing of the day.

Beyond the fields the snow-crowned mountains rise;

Their rugged peaks seem touching cloudless skies.  
The distant pueblo's walls are tinged with gold  
By rays of dying sun. The day is old.

The landscape slumbers in a golden dream.  
The brown adobe glistens in the gleam;  
And now the glowing sun sinks from the sight,  
While shadowy twilight deepens into night.

## AN EVERY-DAY HERO

BY PAUL FRANCIS GLEESON (AGE 11)

*(Silver Badge)*

"THIS is going to be an unlucky voyage," Tim, the boatswain announced; and the rest of the submarine crew decided he was crazy and refused to listen. The shrill whistle put an end to the discussion, as they were ordered below. A few minutes later, they were speeding down the bay and out into open sea. The captain gave the quick order to submerge. Hatches were quickly sealed and all else made close, and they sank. Down they went twelve fathom, and stopped. The captain wished to make somespeed trials.

They were going along at a good six-knot gait when the accident occurred. With a crash, the air seemed full of blankets, crockery, and many other things. The submarine was slanting at about sixty degrees. The few men who had kept their feet rushed to see what was the matter.



"A HEADING FOR JUNE"

BY BETTY CUNNINGHAM, AGE 14

Something had broken in the machinery. They found themselves in darkness. "Electricity out of order and salt-water getting in. Look out for gas!" sang out the electrician. It came, and was unbearable. The men tried to find some way of escape, but in vain. Dunne, the machinist, spoke up: "I am slim. I could crawl through that tube and signal for help."

At first, the captain refused; but at last he gave in. Dunne crawled through, and after getting on the sloping desk, signaled madly. Two ships passed without noticing, and then an oil tug came to the rescue. Here is where we talk of every-day heroes. Heroes are welcomed with bands and cheers. The only thing Dunne heard was the clanging of ambulance bells and the whistles of the wrecker. Don't you think he was a hero? I do.

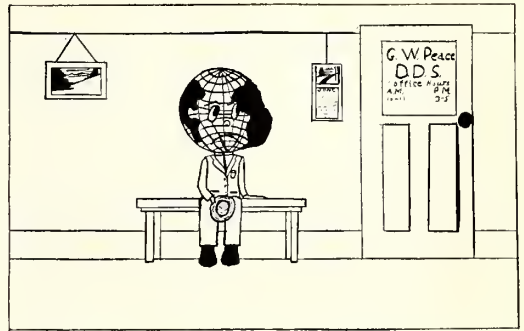

"WAITING." BY ALICE J. FELDMAN, AGE 14. (SILVER BADGE)

## IN MEADOWS GREEN

BY AMY ARMITAGE (AGE 14)

*(Gold Badge. Silver Badge won November, 1921)*

OH, who will come and roam with me  
In meadows green, at dawn,  
Just when the wee immortal folk  
To Fairyland have gone?

The fields will sparkling be, with dew,  
And bathed in golden light  
From Phœbus of the silver bow,  
On his Olympian height.

Sweet with the scent of new-mown hay  
And restful will they be.  
Your spirit light as thistle-down  
Will seem, and quite as free.

Oh, come and roam, this morn, with me  
In pleasant meadows green.  
I promise you, more lovely sight  
Your eyes have never seen.

## IN MEADOWS GREEN

BY DOROTHEA SCUDDER (AGE 12)

IN meadows green I wandered,  
By many a rippling stream,  
Where early rushes whisper,  
Where the first violets gleam.  
And, oh, I felt like singing,  
And I did not know why.  
The sunshine gleamed about me,  
And bright blue was the sky.

When in a budding apple-tree  
I heard a bluebird sing,  
I knew at last why I was glad.  
And cried, "'T is Spring! 'T is Spring!"



"A FAMILIAR SCENE." BY HARRIET DOW, AGE 15



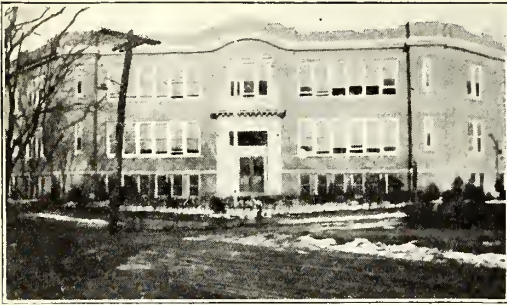

"A FAMILIAR SCENE." "THE SCHOOL-HOUSE." BY MYRTLE C. GODFREY, AGE 13

### AN EVERY-DAY HERO

BY HELENA M. GLENN (AGE 12)

(Silver Badge)

NOT all heroes are men who have won victories on the battle-field. Did we ever think that a doctor is a hero?

At the time of the building of the Panama Canal, many of our men died of yellow fever. If it had not been for Dr. Lazear, Dr. Finlay, Dr. Reed, and their brave followers, people might still be dying with that terrible disease which they did so much to destroy.

Four doctors were sent to Cuba to investigate the disease, thus offering their lives to one of the great causes of humanity. Eleven persons allowed themselves to be bitten by the mosquito, in order to prove that it was this insect, known as *Stegomyia fasciata*, which carried the disease. One, Dr. Lazear, died.

At the time when the first telegraph line was set up, Dr. W. T. G. Morton, of Boston, acting on the suggestion of Dr. Charles T. Jackson, was endeavoring to produce artificial sleep by the breathing of the vapor of ether. He believed that if this was successful, all suffering under the surgeon's knife would be at an end. He did succeed; and it was made known to the world at the Massachusetts General Hospital, in Boston, in 1846. The inscription on Dr. Morton's monument truthfully declares: "Before that discovery, surgery was agony; since, science has controlled pain."

We may say that doctors like these are heroes, but we might not think that our own physician is one. He is! Often he will have to go visiting sick people for days with only a few hours' sleep. He is not able to enter into many social affairs like other men; but he will get his reward sometime.

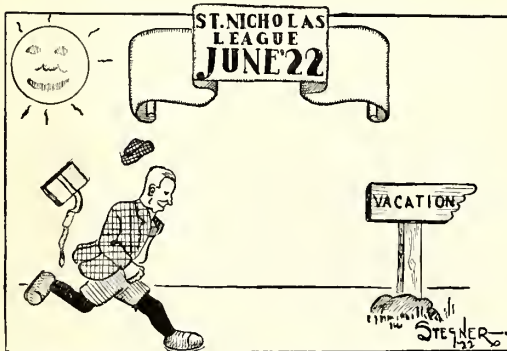

"A HEADING FOR JUNE." BY BENTLEY B. STEGNER, AGE 12

### IN MEADOWS GREEN

BY ELINOR COBB (AGE 12)

(Silver Badge)

I STAND within a city wall,  
But I still hear the meadows call,  
And long the more to steal away  
Into the country fields and play.

I 'd hear the rivers singing there,  
And happy bird songs fill the air;  
The wild rose would be blooming bright,  
And softly shine the gold sunlight.

In daisy fields I long to stray,  
And follow the brooklet on its way,  
Past hill and copse and clump of fern,  
The secrets of the birds to learn.

Thus would I wander through the day  
Where blooming spring-tide meadows lay,  
Nor till the night had come again,  
Would seek the walled-in haunts of men.



"A FAMILIAR SCENE." BY VIRGINIA DAVIN, AGE 11

### SPECIAL MENTION

A list of those whose work would have been used had space permitted:

#### PROSE

Sheila Delap  
Esther P. Walcott  
Wilhelmina Rankin  
Barbara Hastings  
Eleanor Byers  
Mary C. Hamilton  
Carlan S. Messler  
Mary Abby Hurd  
Beatrice Greenough  
Elizabeth Cleveland  
Doreen H. Foote  
Margaret Hoening  
Ellen A. Frank  
Peggy Davidson  
Mary C. Gain  
Charlie Wakefield  
Rosemary Arford  
Elizabeth P. Moffatt  
Charlotte Gleason  
Eleanor M.  
McClintock  
Marjorie A. Wallace  
William W. Grose  
Margaret P.  
Coleman  
Magdalen Haskell  
Hendrietta Bannon  
Mildred S. Gleason  
Ruby Hammer  
Betty Gould  
Phyllis C. Taylor  
Clarence Peterson  
Barbara Simson  
Ruth F. Zentler  
Margaret Rankin  
Marian Brimhall  
Marie L. Schroen  
Shirley Noble

#### VERSE

Charlotte Churchill  
Mayline Donnelly  
Lael Tucker  
Marion Thompson  
Viola S. Wendt  
Blanche L.  
Cunningham  
Frances Colwell  
Margaret  
Montgomery  
Adelaide Sterling  
Polly Vilas  
Madeline Blossom  
Josephine Rankin  
Dorothy M. Watts  
Ruth E. Gillam  
Kenneth Clair  
Marian H.  
Stanwood  
Julia Carhe  
Robert Benn  
Charlotte E.  
Farquhar  
Carroll N. Smith  
Muffe Lord  
Blanche Zliffe  
Ruth G. Ashen  
Eloise Frances  
Kelllogg  
A. Valentina  
Puigiuse  
Gertrude D. Hill  
Charlotte M.  
Reynolds  
Marjorie E.  
St. Pierre  
Helen Louise  
Whitehouse

Marion West  
Margaret J. Hein  
Evelyn Boardman  
Laura Breesse  
Peggy Bennett  
Ellen C. Wells  
Katherine Dines  
Mary Florence  
Mang

#### DRAWINGS

Marguerite Wenig  
Margaret Coates  
Julia H. Brodt  
Margaret Howell  
Edward F. Dana  
Elizabeth E. Moise  
Grace Herman  
Elsbeth Steadman  
Alice Miller  
Helen H. Hodge  
Anne O. Porter  
Ruth Whitten  
Marion C. Smith  
Meredith A. Scott  
Faustina Munro  
Beatrice R. Parvin

#### PHOTOGRAPHS

Elizabeth Morton  
Maria Luisa de la  
Torriente  
Helen Loeffler  
Hilda B. Howes  
Eleanor D. Reed  
Edward M. Kenly  
Maxine Cushing  
Jack S. Booth  
Marianna Irwin  
William R. Moses

ROLL OF HONOR

A list of those whose contributions were deserving of high praise:

PROSE

- Vernon Munroe, Jr.
- Andrew H. Foss, Jr.
- Maria Fletcher
- Elmira Heritage
- Olive V. Whitten
- Arlene McPheters
- Vernon Munroe, Jr.
- Ruth Proctor
- Regina Wiley
- Annie B. Curtis
- Florence Comminger
- Jeanne Cannon
- Yetta Goldberg
- Muriel Hockdorf
- Dorothy M. Brown
- Margaret Griffith
- Lucile Rosenbaum
- Virginia Vaughan
- Arthur Carson
- Katherine Lewis
- Aileen Peckham
- Frances L. Stabie
- Katharine Krieg
- Arthur Mitchell
- John Hein
- Iola M. Hobbs
- Nina Lowenstein
- Ruth E. Lindsay
- Catherine Herbert
- Florence Warburton
- Roy B. Murphy
- Margaret Harkness
- Frances E. Miller
- Winifred E. Carnoy
- Emma Palmer
- Elmira Horning
- Betty Grubs
- Gloria F. Finch
- Rose Ginsberg
- Phoebe E. Baker
- Doris Embree
- Virginia Powell

Sophie Rudd

- W. Willard Messler
- Meta Bradley
- Alida G. Parks
- Jeanette A. Thurston
- Leona Schwegler
- Dorothy Jensen
- Shirley Waehler
- Lois Buswell
- Mary L. Burrowes
- Alice M. Johnson
- Elizabeth Hardaway

DRAWINGS

- Kathleen Murray
- Joe Griffin
- Howard B. French
- Emilie Heilprin
- Amy Osborne
- Constance V. Carrier
- Lillian Aspell
- Dorothy Bartlett
- Ruth J. Asire
- Katherine Conway
- Helen S. Johnson
- Mary S. Bryan
- Elease Weiss
- Marion Harris
- Katharine A. Shand
- Montague A. Anderson
- Madeline Greene
- Elizabeth Fish
- Jean Moore
- Barbara Lamb
- Donald Rosencrantz
- Mac Hesler
- Laura M. Haley

PHOTOGRAPHS

- Shirley E. Scott
- Marion L. Smith
- Edith Callaghan
- Agnes Mongan
- Frances Coppage
- Mabel Merriam
- George F. Weld, Jr.
- Dorothy D. Talman
- Gardner Barker
- Tom Mills
- Esther Lewis
- Virginia Myerly
- Virginia Cherrill
- Anne Tilner
- Gertrude Frieschman
- Fidelity Farnum
- Ruth Parker
- Carola Trittin
- Annie Lee Pickett
- Martha Denny
- Philip Dey Eastman
- Margaret Farrar
- Iris Houston
- Isabella N. Laughton
- Quita Woodward
- Genevieve Derschud
- Florence Le Boutillier
- Amy Evans
- Miriam Knoer
- Esther Blum
- Sylvia Kodjbanoff
- Mary T. Shepard
- Alice McNeal
- Dempsey Weaver
- III
- Anna R. Weaver
- Marjorie G. Blue
- Bertina Ford
- Berta Marturet

WHAT THE LEAGUE IS

THE ST. NICHOLAS LEAGUE is an organization of the readers of the ST. NICHOLAS MAGAZINE.

THE LEAGUE motto is "Live to learn and learn to live."

THE LEAGUE emblem is the "Stars and Stripes."

THE LEAGUE membership button bears the LEAGUE name and emblem.

THE ST. NICHOLAS LEAGUE organized in November, 1899, became immediately popular with earnest and enlightened young folks, and now is widely recognized as one of the great artistic educational factors in the life of American boys and girls.

THE ST. NICHOLAS LEAGUE awards gold and silver badges each month for the best original poems, stories, drawings, photographs, puzzles, and puzzle answers.

PRIZE COMPETITION, No. 271

Competition No. 271 will close July 1. All contributions intended for it must be mailed on or before that date. Prize announcements will be made and the selected contributions published in ST. NICHOLAS for October. Badges sent one month later.

**Verse.** To contain not more than twenty-four lines. Subject, "Turn of the Tide," or "Indian Summer."

**Prose.** Essay or story of not more than three hundred words. Subject, "Playing the Game."

**Photograph.** Any size, mounted or unmounted; no blue prints or negatives. Young photographers need not develop and print their pictures themselves. Subject, "When the Camera Clicked."

**Drawing.** India ink, very black writing-ink, or wash. Subject, "At Work," or "A Heading for October."

**Puzzle.** Must be accompanied by answer in full.

**Puzzle Answers.** Best and neatest complete set of answers to puzzles in this issue of ST. NICHOLAS. Must be addressed to THE RIDDLE-BOX.

No unused contribution can be returned unless it is accompanied by a self-addressed and stamped envelop of proper size to hold the manuscript or picture.

RULES

ANY reader of ST. NICHOLAS, whether a subscriber or not, is entitled to LEAGUE membership, and upon application a League badge and leaflet will be sent free. No League member who has reached the age of eighteen years may compete.

Every contribution, of whatever kind, must bear the name, age, and address of the sender and be indorsed as "original" by parent, teacher, or guardian, who must be convinced beyond doubt—and must state in writing—that the contribution is not copied, but wholly the work and idea of the sender.

If prose, the number of words should also be added. These notes must not be on a separate sheet, but on the contribution itself—if manuscript, on the upper margin; if a picture, on the margin or back. Write in ink on one side of the paper only. A contributor may send but one contribution a month—not one of each kind, but one only; this, however, does not include "competitions" in the advertising pages or "Answers to Puzzles."

Address: The St. Nicholas League, The Century Co. 353 Fourth Avenue, New York.

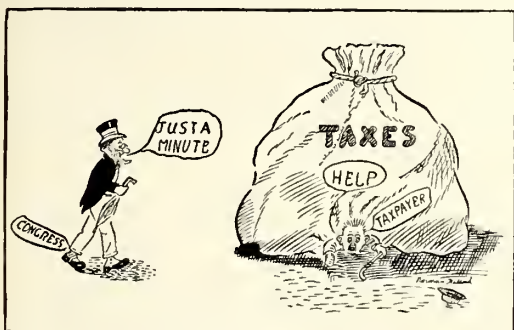

"WAITING." BY NORMAN HALLOCK, AGE 14. (SILVER BADGE)

VERSE

- Josie Chapdelaine
- Merva Martin
- Josephine Munroe
- Susan Clayton
- Armat Duhart
- Amelia Bachman
- Catherine Crook
- Virginia L. Taylor
- Hilda F. Harris
- Mary Koch
- Elizabeth Brooks
- Margaret Durick
- Emily Baker
- Janet McNeir
- Virginia Jacobs
- Fannie Blank
- Dorothy Fetvedt
- Gladys Phillips
- Charlotte L. Fischer
- Elizabeth Dargan
- Barbara Childs

WALTON CHRISTIAN

- Mary E. Hogg
- Betty Carrington
- Laurence Kittredge
- Frances Worthington
- Robert Eddy
- Marian Cannon
- Marjorie Allen
- Edward L. Grueby
- Janet Ross
- Alpa Whitney
- Elizabeth Rex
- Wallace Kingsbury
- Dorothy W. Doty
- Margaret Buck
- Margaret Gibson
- Sally P. Lea
- R. S. Childs
- Robert Cressey
- Gladys Bryan
- Marian A. Clark
- Elsa Johnson

Puzzles

- B. Newman
- Rosalind Howe
- Lewis N. Clark
- Winifred Stahly
- Susan E. Lyman
- Robert Eddy
- Charles E. Smith
- Ellen Morehouse
- Frances Emerson
- Sally Vredenburg
- Alice Gephart
- Bernice Rasmussen
- Helen Demetry
- George R. Hinman
- Jeanette Whitty
- Fontleroi Temple
- Eleanor Fry
- Ann Donnell
- Emma L. Miescher
- Jean Wheeler
- Margaret Barnett



## THE LETTER-BOX

JACKSONVILLE, FLA.

DEAR ST. NICHOLAS: I have just started you a month ago, but this does not mean that I am not familiar with you, because I am. My little friend took you and I borrowed you and liked you so much that I had to have you all for myself, and now I don't see how I ever could have done otherwise.

You are the topic of nearly every school-girl's conversation—for I hear them all say: "Do you take the ST. NICHOLAS? Is n't it grand? And did you read 'The Turner Twins?'" This morning you arrived before breakfast and I could not begin before I searched your contents. I just love THE WATCH TOWER. You can't imagine how much I enjoy you.

I always will remain,

Your devoted reader,  
POLLY HARDEE (AGE 13).

NEW YORK, N. Y.

DEAR ST. NICHOLAS: I have taken you for three or four years, and I think you are lovely. My sister and I always try to get you first.

Last year, our graduating class gave the play



THE QUEEN, KING, AND FAIRY, IN "I 'LL TRY"

"I 'll Try," just before graduation. We changed it a little bit, and my teacher wrote a little scene on the end where *Caroline* has a little friend *Virginia* come and teach her how to speak English correctly. I was *Virginia*. Afterward, we took some pictures of certain scenes in the play. I am sending them in this letter.

With best wishes,  
DOROTHY PEASE (AGE 11).

BERKELEY, CALIF.

DEAR ST. NICHOLAS: I have taken you for two years and would n't like to part with you for anything.

Maybe you would be interested in an adventure we had one summer near Lake Tahoe, on Fallen Leaf Lake.

We started in the morning on a hike to two small mountain lakes; but as the trails were poorly marked, we took the wrong turn. We kept on going until we saw the lakes below and back of us.

We ate our lunch and started off again. We met the dam-keeper. He told us to keep on and we would come to Lake of the Woods, where a trail leading to the right would take us a shorter way back to camp. We passed the turn, and went on and on until we came to Desolation Valley. It sure looked like desolation! We hunted around to find a trail, but we had to go back through the woods until we came to Lake Marjorie. When we got to Lake Marjorie some campers directed us to a trail, which they said was good, that led down the hill, past Grass Lake, to our camp. We found it very steep and rocky. It was late in the afternoon, and we would n't have time to get down before night, but we started.

I was riding a donkey, because my leg was in a plaster, as I had had infantile paralysis. Mother and Daddy were walking. The trail was so bad I had to get off my donkey and crawl down to the lower level. The donkey, left to himself, easily jumped from rock to rock and we all got down safely.

By this time it was too dark to see the trail, so we wrapped in the saddle-blankets and built a fire, but even then it was pretty cold.

For supper we had an orange apiece, and for breakfast, a third of a stick of gum apiece. We started off at daylight, and were glad to get back to camp and our beds, where we slept most of the day.

Your true friend,  
CATHERINE STEMBRIDGE.

MANLY, NEW SOUTH WALES.

DEAR ST. NICHOLAS: As I was (and I am still) a member of the ST. NICHOLAS LEAGUE when I lived in Canada, I thought that I would write and tell you how I like living in Australia.

I have been living here for only five months, and when I arrived here in April it was the autumn, and to me it seemed so funny; for when I left Montreal in March, it was just the end of the winter.

They do not have any snow here in Sydney, although they have some up in the mountains. There was great excitement when there was a heavy fall of snow (about twelve inches) up at Golbourn, a place farther north.

Sydney is a very beautiful place, and Manly, where I live, is situated on the opposite end of the harbor from Sydney proper and is a great summer resort, as we have a lovely ocean beach as well as a harbor one.

I have just finished reading an old bound volume of ST. NICHOLAS for the year 1883, and it was so nice to read the letters of the little girls of that period (who, I expect, have little girls of their own now) writing to say how much they enjoyed the ST. NICHOLAS of that day.

We are not able to get the ST. NICHOLAS very regularly here now, as it is difficult to obtain very many American magazines; but as Dad belongs to the library in Sydney, he brings it home as often as he can, and then there is a general scramble, and cries of, "Mother, make her give it to me!" "But I got it first!" and such.

With best wishes for life-long prosperity, I am,  
Your devoted reader,  
CHRISTINE FRASER (AGE 14).

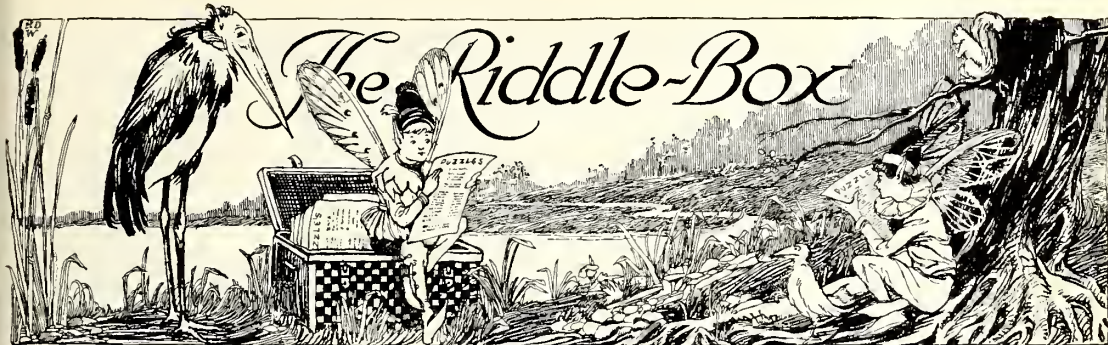

## ANSWERS TO PUZZLES IN THE MAY NUMBER

**CHARADE.** Adam-ant, adamant.  
**DIAMONDS.** 1. M. 2. Pau. 3. Maple. 4. Uln. 5. E. II. 1. B. 2. Tea. 3. Beech. 4. Act. 5. H. III. 1. A. 2. Ape. 3. Apple. 4. Ell. 5. E. IV. 1. P. 2. Pea. 3. Peach. 4. Ace. 5. H.  
**ZIGZAG.** Miguel de Cervantes. Cross-words: 1. Music. 2. Oiled. 3. Negro. 4. Thrum. 5. Rifle. 6. Eagle. 7. Ardor. 8. Legal. 9. Cubit. 10. Peach. 11. Barge. 12. Olive. 13. Tibia. 14. Crane. 15. Latin. 16. Petal. 17. Spare.  
**CHANGED FINALS.** Pad, pal, pan, pas, pat, Pau, paw, pay.  
**CROSS-WORD ENIGMA.** Memorial Day.  
**PICTURED ANSWERS.** I. Horseshoe. II. Clotheshorse. III. Scissors. IV. Orange.  
**CENTRAL ACROSTIC.** Victory. Cross-words: 1. Haven. 2. Pride. 3. Bacon. 4. Later. 5. Stove. 6. Party. 7. Layer.  
**BROKEN NAMES.** 1. Asparagus. 2. Artichoke. 3. Rhubarb. 4. Cabbage. 5. Onion. 6. Spinach. 7. Parsnip. 8. Carrot. 9. Tomato. 10. Turnip. 11. Radish. 12. Lettuce.

**BIRD PUZZLE.** Pepacton. Cross-words: 1. Pelican. 2. Eaglets. 3. Peacock. 4. Antwren. 5. Catbird. 6. Tanager. 7. Ostrich. 8. Nunbird.

**DOUBLE DIAGONALS.** Diagonals, Shakespcare, Robert Burns. Cross-words: 1. Summer. 2. Shiloh. 3. Enable. 4. Weekly. 5. Drivel. 6. Tigers. 7. Abrupt. 8. Truest. 9. Dwarfs. 10. Argent. 11. Ethics.

**P.** Now rings the woodland loud and long;  
 The distance takes a lovelier hue,  
 And drowned in yonder living blue  
 The lark becomes a sightless song.

**NOVELIST'S PUZZLE.** Initials, David Copperfield; 1 to 14, Charles Dickens; 15 to 26, Barnaby Rudge; 27 to 42, Old Curiosity Shop; 43 to 53, Oliver Twist; 54 to 68, Tale of Two Cities. Cross-words: 1. Daring. 2. Ascend. 3. Viking. 4. Ignite. 5. Dehort. 6. Coolie. 7. Obvert. 8. Pacify. 9. Poplar. 10. Earthy. 11. Robber. 12. Fiddle. 13. Issues. 14. Eschew. 15. Lowest. 16. Dulcet.

**TO OUR PUZZLERS:** To be acknowledged in the magazine, answers must be mailed not later than June 27 and should be addressed to ST. NICHOLAS RIDDLE-BOX, care of THE CENTURY CO., 353 Fourth Avenue, New York City, N. Y. Solvers wishing to compete for prizes must comply with the LEAGUE rules (see page 893) and give answers *in full*, following the plan of those printed above.

**ANSWERS TO ALL THE PUZZLES IN THE MARCH NUMBER** were duly received from Miriam J. Stewart—Elizabeth Elich—Arthur Knox, Jr.—Kemper Hall Chapter—Eighth Grade, Slayton—John F. Davis.

**ANSWERS TO PUZZLES IN THE MARCH NUMBER** were duly received from Priscilla Manning, 10—June M. Hinman, 10—Ruth Eddy, 10—Helen H. McIver, 10—Florence E. Jackson, 10—Elizabeth Tong, 10—Eleanor Thomas, 10—Dorothy N. Teulon, 10—Sphinx, 10—Helen C. Sayward, 9—Clarissa Wardwell, 9—"Two F's," 9—Helen A. Moulton, 9—Josephine Quarry, 9—Alice G. Hopkins, 8—Sylvia Kodjbanoff, 8—Roman Kopec, 8—Virginia B. Leak, 8—Four "J's," 7—Gertrude R. Jasper, 7—Janet Rosewald, 7—Carlan S. Messler, 7—Judith Haight, 7—Alma Miller, 7—M. C. Neal, 6—E. Palmer, 6—J. P. Doyle, 6—"Blackie," 6—J. Jenkins, 6—M. L. Stowell, 5—M. McCracken, 5—E. O'Neill, 5—G. G. Cameron, 5—M. C. Fassitt, 5—Miss McKinney, 5—M. Cushing, 5—S. E. Gaston, 5—M. W. Messler, 5—E. Kimball, 5. Four answers: V. Rix—I. M. Gwynne—A. Winston—F. Olmsted—E. Rosenberg—A. Goldecke—H. McBride. Three: E. W.—G. H.—E. G.—S. E. R.—C. S.—M. McB.—H. G. H.—M. H. C.—E. B. B.—N. L.—Y. G. C.—L. K.—A. M. B.—St. N. Club—A. B. Two: M. C.—E. L. D.—D. A.—C. F.—D. S.—R. A. W.—M. D.—K. A. P.—M. D. F.—E. W.—C. W.—M. H. G.—M. H. C.—D. L.—F. McC.—G. F. B.—N. C.—V. C.—H. S. H.—H. B.—E. J. B.—E. F.—J. R. L.—C. M. W.—N. P.—E. T.—N. R.—E. B. K.—A. T. P. For lack of space, the initials of solvers sending but one answer can not be printed.

### DIAGONAL

All the words described contain the same number of letters. When rightly guessed and written one below another, the diagonal, from the upper left-hand letter to the lower right-hand letter, will spell the name of a wizard of to-day.

**CROSS-WORDS:** 1. Thoroughwort. 2. Alfalfa. 3. Vervain. 4. Pertaining to a bulb. 5. The stone-root. 6. The windflower. 7. A sea-carnation.  
 CHRISTINE L. PHELPS (age 12), *League Member*.

### TRIPLE BEHEADINGS AND TRIPLE CURTAILINGS

**EXAMPLE:** Triply behead and triply curtail one who sets free, and leave an epoch. **ANSWER:** Lib-er-a-tor.

1. Triply behead and triply curtail a loud roaring, and leave vulgar.
2. Triply behead and triply curtail to copy, and leave a measure of length.
3. Triply behead and triply curtail a leader, and leave a human being.
4. Triply behead and triply curtail a collection of animals, and leave a period.
5. Triply behead and triply curtail verified, and leave a tree.

6. Triply behead and triply curtail capable, and leave to caress.

7. Triply behead and triply curtail remembering, and leave everything.

8. Triply behead and triply curtail reluctant, and leave sick.

9. Triply behead and triply curtail adversaries, and leave a number.

10. Triply behead and triply curtail writing carelessly, and leave a tool.

The ten three-letter words being written one below another, the zigzag spells the surname of a famous American.

ELEANOR THOMAS (age 13), *League Member*.

### PRIMAL ACROSTIC

All the words described contain the same number of letters. When rightly guessed and written one below another, the primals will name a famous man, and the finals may all be found in the word "ease."

**CROSS-WORDS:** 1. A hint. 2. A unit. 3. To repose. 4. To utilize. 5. A feminine name. 6. A useful insect. 7. A member of a tribe of American Indians. 8. To observe.

MILDRED HOOPER (age 10), *League Member*.



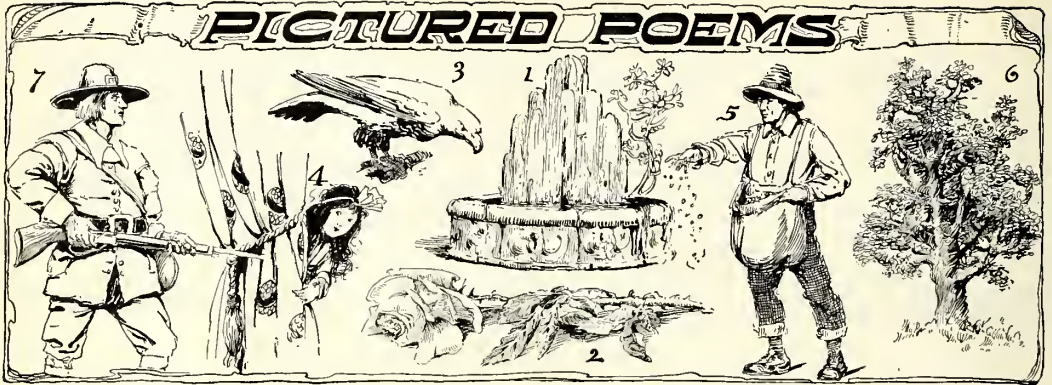

In the above illustration the names of seven poems are pictured. All the poems are by the same writer. What are the poems and who is their author?

**PI**

Sah equilkeen jeun acts slewje no het heart  
 Dan rudent hetm toni wolfser dan trailblin  
 dlibs?  
 O newche heav meco sheet meg-kile marches showe  
 tribh  
 Gribns queencleo dan voj oto ragnd rof sword?  
 GEORGE ROGER HINMAN (age 10), *League Member.*

**CONNECTED DIAMONDS**

I. UPPER DIAMOND: 1. In dared. 2. A measure of length. 3. More advanced in years. 4. A protected place. 5. In dared.  
 II. LEFT-HAND DIAMOND: 1. In dared. 2. A partner. 3. One who consumes food. 4. To allow. 5. In dare.  
 III. RIGHT-HAND DIAMOND: 1. In dared. 2. To corrode. 3. Fast. 4. A metal. 5. In dared.  
 IV. LOWER DIAMOND: 1. In dared. 2. A small child. 3. Roamed. 4. A beverage. 5. In dared.  
 KINGSLEY KAHLER (age 13), *League Member.*

**CROSS-WORD ENIGMA**

My first is in heliotrope, but not in cyclamen;  
 My second in cyclamen, but not in daffodil;  
 My third is in daffodil, but not in hollyhock;  
 My fourth is in hollyhock, but not in nasturtium;  
 My fifth is in nasturtium, but not in peony;  
 My sixth is in peony, but not in buttercup;  
 My seventh is in buttercup, but not in fuchsia;  
 My eighth is in fuchsia, but not in violet,  
 My whole is a fragrant flower.  
 ELIZABETH GRAY OTIS (age 13), *League Member.*

**NUMERICAL ENIGMA**

I am composed of thirty-nine letters and form a quotation that many persons already bear in mind.  
 My 9-21-13-3 is at a distance. My 29-18-37-23-14 were once powerful in Spain. My 39-26-15-33-5 is a city sometimes called "La Superba." My 11-7-31-28-4 is the number of sides to a triangle. My 34-17-19-24-12 is foam. My 35-10-1-6-25 is violent anger. My 2-36-22-16-27 is a serv-

ant who has charge of horses. My 20-30-38-8-32 is said to be the root of all evil.

**WORD-SQUARES**

I. 1. To throw. 2. Extent. 3. To appear. 4. To reduce from native wildness.  
 II. 1. A journey. 2. Was conveyed. 3. Notion. 4. A kind of fuel.  
 III. 1. An outer garment. 2. At a distance. 3. Bodily distress. 4. A sea eagle.  
 ADA CRANE (age 11), *League Member.*

**CHARADE**

The name of a boy is my first;  
 My second is sometimes a letter;  
 My third is a sin, it is true—  
 To shun it would always be better.  
 My last is a word you can write;  
 My whole is a flower small and bright.  
 VIOLET A. RANKIN (age 13), *League Member.*

**NOVEL ZIGZAG**

(Gold Badge, ST. NICHOLAS LEAGUE Competition)

* . . . 58	1 . . . 31	43	CROSS-WORDS:
. . . 17	41 . . . 18	. . . 16	1. Inspid. 2.
. . . 35	* 2 . . . 34	. . . 15	A June dessert.
. . . 22	* . . . 3	. . . 14	3. Protected. 4.
49 . . . 4	* 57 . . . 28	. . . 13	A dunce. 5. One
. . . 12	. . . 27	* . . . 21	42 who makes mis-
. . . 46	. . . 5	* . . . 10	takes. 6. A port-
. . . 11	. . . 38	. . . 9	able case for hold-
. . . 14	. . . 54	29 . . . 8	ing loose papers.
33 . . . 53	. . . 6	* . . . 44	7. A defamer. 8.
. . . . .	. . . 8	* . . . 37	52 An instrument
13 . . . 30	. . . 25	* . . . 15	for indicating the
. . . 55	. . . * 56	7 . . . 12	number of steps
39 . . . * 19	. . . . .	. . . 48	taken in walking.
. . . 40	* 20 . . . 36	9 . . . 11	9. Carnage. 10.
45 * 10 . . . 23	. . . 50	47 . . . 10	A mild radiance
* . . . 32	. . . 26	51 24 . . . 9	in the west after

distinct animals larger than elephants. 12. An official who pays salaries. 13. Becoming crimson. 14. The state of being bent or curved. 15. Making deeper. 16. Lighted up. 17. Conveys from one place to another.

When these words have been rightly guessed, the zigzag will spell the name of a mighty hunter. The letters indicated by the figures from 1 to 5, from 6 to 9, from 10 to 16, from 17 to 21, from 22 to 28, from 29 to 33, from 34 to 43, from 44 to 53, and from 54 to 58 will name nine wild animals.  
 CHARLES EUGENE SMITH (age 14).



## *Take a Kodak with you*

It's all so easy the Kodak way, and the pictures, precious at the time, will be priceless to you later. You can spend your vacation and have it, too—in pictures.

*Autographic Kodaks \$6.50 up*

Eastman Kodak Co., Rochester, N. Y., *The Kodak City*



# Happy Kiddies Wear **PAUL JONES MIDDIES**

**C**LOTHES the kiddies themselves are really proud to wear! Clothes that delight the fondest parent's eye. Such clothes are Paul Jones Suits and Middies for little boys and girls.

Every Paul Jones garment is guaranteed to give real wear. The braid and the buttons are sewed on for "keeps." The seams are perfect inside and out. The materials defy all sorts of rough and tumble play.

Paul Jones Boys' Suits and Middies are the finest you can buy—and all things considered, the most inexpensive, too.

Write direct to us if your dealer cannot supply you.

**MORRIS & COMPANY, Inc.**  
Dept. A-5, Baltimore, Md.



Look for  
this label.



## These Movie Stars —Your Summer Guests

The Victor Safety Cinema and our libraries of thousands of wholesome entertainment and educational films bring to your own home or summer camp the leading moving picture stars as your guests. Norma Talmadge, Charles Ray, Mary Pickford, Douglas Fairbanks, Vivian Martin are but a few that you can invite from our libraries on short notice, regardless of where you live.

The Victor Safety Cinema is portable, uses non-inflammable films, simple to operate and fully guaranteed. The lowest priced quality machine. \$225.00. No down payment.

Ask for booklet A-Y  
and our special  
free trial offer.



**United Projector  
& Film Corp.**

69 West Mohawk Street  
Buffalo, N. Y.

## "Old Town Canoes" The Sponson

Teach the youngsters how to paddle an "Old Town Sponson Canoe." Air-chambers on the side make it safe as a rowboat. \$54 up from dealers or factory. Choose your model from new catalog—illustrations in color. Write for it.

**OLD TOWN CANOE COMPANY**  
246 Fourth St., Old Town, Maine, U. S. A.



## 30 Days' Free Trial

Select from 44 Styles, colors and sizes, famous **Ranger** bicycles. Delivered free on approval, express prepaid, at **Factory Prices**. You can easily save \$10 to \$25 on your bicycle.

**12 Months to Pay** on any Ranger if desired. Parents and girls can easily earn small monthly payments.

**Tires** Lamps, wheels and equipment, low prices. Send **No Money**, do business direct with makers.

**Mead Cycle Company**  
Dept. A15 Chicago

Write today for free Ranger Catalog, factory prices and marvelous easy payment terms



# ABINGDON

THESE are the books you want for quiet hours on rainy days, and to read by lamp-light before the fire on winter nights. Books that are full of adventure and interesting people in strange places. And books, too, of this big country of ours, stories of its earlier days, and stories of the stirring events that we remember today with song and celebration.

Abingdon Books are the kind you will want to put on your own particular shelf. The men and women who write Abingdon Books for boys and girls are people who understand so well the things you are looking for. They have not forgotten the stories they liked best when they were as old as you, and so are the best tellers of tales now.

All good book-stores have these Abingdon Books for boys and girls.

## *Books for Boys and Girls*

### THE "LITTLE FOLKS" SERIES

*By Dorothy Donnell Calhoun*

Fascinating books for children, with a distinct educational value.

#### LITTLE FOLKS IN HISTORY

Mrs. Calhoun knows just how to write for children, and these sixteen fascinating stories, with the charm of romance and history, will be eagerly read by the little ones. Illustrated. Four books. Per book, net, 50c.

#### LITTLE FOLKS OF THE BIBLE

Portrays child life from the Bible, and tells in a pleasing style the stories of Isaac, Joseph, Benjamin and other little folks we have learned to love in sacred history. Illustrated. Four books. Per book, net, 50c.

#### LITTLE FOLKS IN ART

Happy the children in whose hands these books are placed. In a plain, clear, simple style they tell about the famous artists and the stories of the pictures themselves. Illustrated. Four books. Per book, net, 50c.

#### LITTLE FOLKS FROM LITERATURE

David Copperfield, Lorna Doone, Paul and Virginia and others of the best juniors. . . . a collection of stories and poems which cultivate a desire for the best books. Illustrated. Four books. Per book, net, 50c.

### OVERLAND FOR GOLD

*By Frank H. Cheley*

"Mr. Cheley writes chiefly for boys—real American boys, and this book is a story of the Colorado gold excitement, the days of wagon trains, Indian attacks, desert, mountains and death. Action is found on every page, and its historical setting gives it value as well as charm."—Pittsburgh Leader.

Price, net, \$1.50, postpaid.

### STORIES FOR EVERY HOLIDAY

*By Carolyn Sherwin Bailey*

"These stories are not only extremely interesting—the very kind of stories that appeal to boys and girls—but they are also calculated to teach the true spirit of the holidays for which they were written. . . . Twenty-seven splendid stories about the days which all true Americans celebrate, and which help us, as a nation, to cultivate the spirit of true Americanism."—The Boys' Friend.

Price, net, \$1.50, postpaid.

### THE BOY WHO LOST HIS NAME

*By Christine Ware*

"In this story that parallels 'The Man Without a Country' and is sure to interest boys, 'the boy' cheats in an examination, plays tricky baseball and bullies a schoolmate. His father punishes him by taking his name away. How the boy gets it back forms an absorbing story."—The Continent.

Price, net, \$1.00, postpaid.

### A TRAVEL BOOK FOR JUNIORS

*By Helen Patten Hanson*

"A very delightful book that would necessarily find a warm welcome in every Christian home is this book of travel. Vivid description in simple language of a boy's experience in Palestine and Egypt since the Great War, it will interest any student of the Bible. It is beautifully printed and contains thirty maps and illustrations. The author has the happy art of telling just what one wishes to know."—Boston Evening Transcript.

Price, net, \$1.25; by mail, \$1.37.

*(Prices are subject to change without notice)*

## THE ABINGDON PRESS

NEW YORK

CINCINNATI



# YEARS AGO

DID MOTHER AND DAD  
EVER APPEAR COSTUMED LIKE THIS?



Dayton Bicycles have been leaders since  
your Dad was a boy

The above illustration is reproduced  
from a Dayton Bicycle catalog of 26  
years ago.

Styles of dress have changed from  
year to year but Dayton Bicycle qual-  
ity has been the same for more than a  
quarter century.

Today the Dayton is supreme in all  
those qualities that mean speed, en-  
durance, easy running—and depend-  
ability.

Our new booklet, "How to Choose a Bi-  
cycle," will be worth while getting. Send for  
yours now. It will help in arriving at a wise  
decision regarding the exact bicycle best suited  
to your needs.

No matter what bike you now own—or what  
kind you want—get a copy of "How to Choose  
a Bicycle" at once. With it we will send (also  
free and postage paid) a copy of our new art  
catalog. Use the coupon at once.

### Cycle Division

The Davis Sewing Machine Co., Dayton, O.

FILL IN—CUT OUT—MAIL TODAY

The Davis Sewing Machine Co., Dayton, O.  
Please send me, without obligation, your booklet No.  
27, "How to Choose a Bicycle" and the 1922 Dayton  
Catalog.  
Name.....  
St. and No.....  
City and State.....  
Age.....

## Statement of the Ownership Management, Circulation, Etc. Required by the Act of Congress of August 24, 1912

of St. NICHOLAS  
published monthly at Concord, N. H.,  
For April 1st, 1922

COUNTY OF NEW YORK }  
STATE OF NEW YORK } ss.

Before me, a *Notary Public* in and for the State and County  
aforesaid, personally appeared W. MORGAN SHUSTER, who,  
having been duly sworn according to law, deposes and says  
that he is the *President* of The Century Co., publisher of St.  
NICHOLAS, and that the following is, to the best of his knowledge  
and belief, a true statement of the ownership, management  
(and if a daily paper, the circulation), etc., of the aforesaid  
publication for the date shown in the above caption, required  
by the Act of August 24, 1912, embodied in section 443, Postal  
Laws and Regulations, printed on the reverse of this form, to  
wit:

1. That the names and addresses of the publisher, editor, managing  
editor, and business managers are:

<i>Name of</i>	<i>Post-Office Address</i>
<i>Publisher</i> , THE CENTURY CO.	353 Fourth Avenue New York, N. Y.
<i>Editor</i> , WILLIAM FAYAL CLARKE,	Searsdale, N. Y.
<i>Managing Editor</i> , NONE.	
<i>Business Managers</i> , NONE.	

2. That the owners are: (Give name and addresses of individual  
owners, or, if a corporation, give its name and the names and addresses  
of stockholders owning or holding 1 per cent or more of the total amount  
of stock.)

*Owners*, THE CENTURY CO.,  
353 Fourth Avenue, New York, N. Y.

*Stockholders*: W. Morgan Shuster, 353 Fourth Avenue,  
New York, N. Y.; William W. Ellsworth, New Hartford,  
Conn.; Geo. L. Wheelock, 353 Fourth Avenue, New York,  
N. Y.; Robert Underwood Johnson, 327 Lexington Avenue,  
New York, N. Y.; Donald Scott, 9 East 9th Street, New York,  
N. Y.; Edith True Drake, 17 East 8th Street, New York, N. Y.;  
W. F. Clarke, Searsdale, N. Y.; George H. Hazen, 381 Fourth  
Avenue, New York, N. Y.; Gardner Hazen, 353 Fourth Avenue,  
New York, N. Y.; Egerton Chichester, 353 Fourth Avenue,  
New York, N. Y.; The Pennsylvania Company, Trustee for  
Josephine Kern Dodge, Philadelphia, Penna.; Estate of Roswell  
Smith, 253 Broadway, New York, N. Y.; Estate of Annie G.  
Smith, 253 Broadway, New York, N. Y.; Wm. Ives Washburn,  
Jr., 353 Fourth Avenue, New York, N. Y.; James Abbott,  
353 Fourth Avenue, New York, N. Y.; Stella S. Chichester, 46  
Kilburn Road, Garden City, N. Y.; A. C. Ferrin, Chester,  
Mass.; Dana H. Ferrin, 353 Fourth Avenue, New York, N. Y.;  
Herbert Adams Gibbons, 12 Boudinot Street, Princeton, N. J.;  
G. Inness Hartley, 344 West 87th Street, New York, N. Y.;  
Geo. Inness, Jr., Cragmoor, N. Y.; Julia G. Inness, Cragmoor,  
N. Y.; Lucy Wheelock, 100 Riverway, Boston, Mass.; Katherine  
H. Parker, Brixton Road, Garden City, N. Y.; Harry A. Franck,  
353 Fourth Avenue, New York, N. Y.

3. That the known bondholders, mortgages, and other security holders,  
owning or holding 1 per cent or more of total amount of bonds, mortgages,  
or other securities are: (If there are none, so state.).....None.

4. That the two paragraphs next above, giving the names of the owners,  
stockholders, and security holders, if any, contain not only the list of  
stockholders and security holders as they appear upon the books of the  
company but also, in cases where the stockholder or security holder ap-  
pears upon the books of the company as trustee or in any other fiduciary  
relation, the name of the person or corporation for whom such trustee is  
acting, is given; also that the said two paragraphs contain statements  
embracing affiant's full knowledge and belief as to the circumstances and  
conditions under which stockholders and security holders who do not  
appear upon the books of the company as trustees, hold stock and securities  
in a capacity other than that of a bona fide owner; and this affiant has  
no reason to believe that any other person, association, or corporation has  
any interest direct or indirect in the said stock, bonds or other securities  
than as so stated by him.

THE CENTURY CO.  
(Signed) W. MORGAN SHUSTER, *President*,  
(Signature of Publisher)

Sworn to and subscribed before me this 28th day of March,  
1922.

JAMES L. TATTAN,  
Notary Public, New York County Clerk's No. 235,  
New York County Register's No. 4032.  
(My commission expires March 30, 1923.)

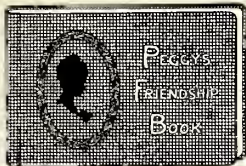

## Have You a Peggy?

An old fashioned Autograph Album in a new cover done in pink, blue or lavender checked gingham.

Every girl and boy should have one.  
Fifty cents, postage prepaid.  
C. P. Ashcraft 6127 Kimbark Ave.  
Chicago, Ill.



## SKATES

Are Young America's First Choice  
Ask your dealer for them.

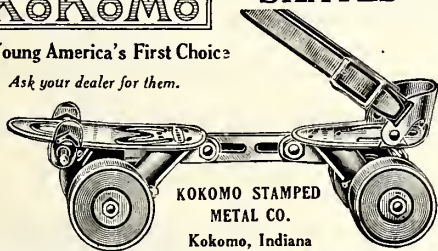

KOKOMO STAMPED  
METAL CO.  
Kokomo, Indiana

## GIRLS GIANT

Will blow  
over 4 feet  
in circumference



## BOYS BALLOON

15¢ By mail  
prepaid  
Stamps accepted



Statue of Liberty printed on each Balloon

Dept. S

603 Third Ave. New York

## Reliability

is the key-word of the ST. NICHOLAS advertisements.

You can also count on the quality of goods advertised in these pages.



## The Camp Test

"Good Sportsmanship" is mightily helped by good equipment.

Boys and girls going to camp should insure their summer's enjoyment by insisting on getting the best—Spalding's.

Spalding Quality will always give more than is expected.

Tennis Rackets	Bathing Suits
Tennis Shoes	Sweaters
Base Ball Gloves	Jerseys
Base Ball Mitts	Hiking Shoes
Bats and Balls	Camp Uniforms



Campers passing through New York City are invited to visit the new Camp Department in the Spalding store, at Fifth Ave. and 43rd St., within three minutes of the Grand Central Station, and convenient to all of the large hotels.

New 1922 edition of "Camps and Camping" now ready. Mailed on receipt of 25 cents.

# A. G. Spalding & Bros

NEW YORK

CHICAGO

SAN FRANCISCO

And other large cities of the United States



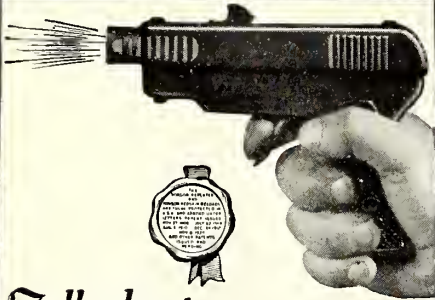

*Talk about*  
**A REGULAR HE-GUN!**

*This is it!*

*It looks like a real automatic revolver  
 It shoots and FLASHES like a real gun  
 It is absolutely harmless*

**YOU'LL** want to own the Ronson Repeater. Every time you pull the trigger it shoots big, red flashes just like a real gun. These flashes are absolutely harmless. You can shoot them anywhere.

You get 5000 flashes before you have to reload. And you don't have to cock the Ronson Repeater—just pull the trigger. The Ronson Repeater has the shape, grip and gun-metal finish of a real automatic revolver. It is strongly made of pressed steel.

Get one at your dealer's. If he doesn't carry the Ronson Repeater, cut out the attached coupon, read the directions, and mail to us. Write us today.

**THE ART METAL WORKS**

27 Aronson Square, Newark, N. J.  
 For 35 years Makers of High Grade  
 Metal Novelties

*The*

**RONSON**

*Trade-mark registered.*

**REPEATER**

*Patented in U. S. A. and abroad*

This wonderful gun  
 costs only

**25¢**

*Also made in polished  
 nickel plate at 50¢.  
 Both are higher in the  
 West and Canada.*

**RONSON REDSKIN  
 RELOADS  
 1000 Shots for  
 One Cent**

Buy several extra red reloads when you get your Ronson Repeater. Every reload shoots 5000 shots. Price 5 cents each; higher in the West and Canada.

*Cut out this coupon*

**THE ART METAL WORKS**

27 ARONSON SQUARE, NEWARK, N. J.

Enclosed find 25 cents in coin or stamps, for which send me one Ronson Repeater, gun-metal finish, loaded for 5000 flashes. (Enclose 10 cents extra if you live west of Chicago or in Canada.)

My name is.....  
 Street.....  
 City.....State.....  
 My dealer's name is.....  
 Street.....



**Only \$1.00**

**"BIG LEAGUE" BOYS' GLOVE**

Equal to \$3 glove. Made like professional's. Genuine tough grain leather front and back. Well padded and deep formed pocket. Just the glove to help you make the team. Satisfaction guaranteed or money refunded. We pay postage. Send \$1 today or order C.O.D. and pay postman \$1.10 on arrival. Smaller sized glove for boys under 11, 85¢; C.O.D. 95¢. When for right hand, specify.

**The Big League Glove Co.  
 Dept. O-1. Dayton, Ohio**

**BOYS**

**\$35 Radio Outfit Free**

for a little easy work. Write at once. **GLEN ELLYN PRODUCTS Co., Glen Ellyn, Ill.**

*P. A. Kinsley Says in  
 The Philadelphia Record  
 of Harry Hervey's*

**"CARAVANS BY NIGHT":**

**"NO** one need despair of the vitality or the wholesomeness of American fiction while there are at work such writers as Harry Hervey, whose novel, 'Caravans by Night,' is published by the Century Co.

"'Caravans by Night' comes as a dash of oxygenated air to a world wearied of breathing the noxious gases of the subterranean caverns, the polluted sewers from which has emanated much of the fiction of recent years. Those whose souls have cried out in protest against the noisome things which novelists have been revealing in will welcome Mr. Hervey's story because of its romantic qualities, its limning of the East in all its magic beauty and irresistible mystery. . ."

**"CARAVANS BY NIGHT"**

*is published by*

**THE CENTURY CO., 353 Fourth Avenue  
 NEW YORK CITY**

**And is sold at all bookstores. The price is \$1.90**



*She lost that  
fear of Sunburn!*



Pack Absorbine, Jr. among your holiday or vacation trappings and you, too, will go and mix wherever good outdoor fun may be had. Use it freely. It is instantly cooling and soothing. It both prevents and stops that tormented condition of the skin after sun exposure, and the soreness and inflammation that follow.

And for played-out muscles after a strenuous outing, apply a few drops to the affected parts. It prevents the lameness and stiffness that might otherwise come.

Know that Absorbine, Jr. combines, in one container, the properties of liniment, antiseptic and germicide. It is safe and of a clean, pleasant odor.

At most druggists, \$1.25, or postpaid. Liberal trial bottle, 10c. postpaid.

W. F. YOUNG, Inc., 360 Temple St., Springfield, Mass.

**Absorbine Jr.**  
THE ANTISEPTIC LINIMENT

**Moore Push-Pins**  
Glass Heads-Steel Points  
**Moore Push-less Hangers**  
To hang up things  
*Ask your dealer to show them.*  
Sold Everywhere **10¢** per packet  
**Moore Push-Pin Co.**  
Wayne Junction Philadelphia

**12 Months to Pay**  
You can easily earn or save money for the small payments. Parents often advance first payment to help buy a **RANGER** bicycle. Choice of 44 styles, colors and sizes. **FACTORY-TO-RIDER** prices. **DELIVERED FREE** express prepaid on approval for **30 DAYS' TRIAL**, actual free riding test. **Tires** prepaid. Lamps, wheels, and equipment, low prices. **Send No Money.**

**Mead Cycle Company**  
Dept. A15 Chicago

Write today for free Ranger Catalog, factory prices and marvelous easy payment terms

**T**O PLACE an advertisement in St. NICHOLAS means that you are bringing the name of your product to the attention of thousands of children and their families all over the United States. These children come from the best homes in the land, and will soon become influential citizens in their communities.

To impress on their young minds the qualities of your merchandise is a big step towards molding the opinion of future customers, as well as a wedge into a tightly closed pocketbook today.

A page in the advertising section of St. NICHOLAS is an excellent investment, and one that pays a high rate of interest.

For further particulars, address

**ST. NICHOLAS MAGAZINE**

353 FOURTH AVENUE

NEW YORK CITY



## Century Juveniles Are Famous

### THE LUCK OF DENEWOOD

By EMILIE BENSON KNIPE and ALDEN ARTHUR KNIPE

**A**NOTHER of the popular Denewood stories, in which the lost lucky sixpence, the Luck of Denewood, is found by charming Beatrice de Soulange, descendant of Stuttering Peg Travers, and her American cousins, whereupon the fortunes of the house of Denewood mend. *Illustrated. Price \$1.75*

### TALES OF TRUE KNIGHTS

By GEORGE PHILIP KRAPP

**A** NUMBER of the marvelous, brave and lovely legends the old chroniclers and minstrels have saved for us, in legend sodim or language so strange that they need be retold for modern readers, have been selected by Professor Krapp of Columbia University and delightfully retold in a form perfectly clear and infinitely fascinating to children. Among the tales are: Sir Cleges; King Horn; Havelock the Dane; Werwolf; Sir Gawain and the Green Knight; The Three Revelers. A beautiful and worth while book.

*Illustrated. Price \$1.75*

### CONQUESTS OF INVENTION

By MARY R. PARKMAN



**N**OT the average compiled book of this kind, but a living, glowing, enthusiastic yet well-balanced account of important inventions which have changed man's material environment by adding to his resources in food, clothing and machine energy; to his range of activity, in the air and under the water; to his ability to communicate quickly and across great distances, etc. It is extremely readable and worth reading. Numerous reviewers have remarked that it should interest both young folk and their elders.

*Illustrated. Price \$2.00*

### KIT, PAT, AND A FEW BOYS

By BETH B. GILCHRIST

Author of "Cinderella's Granddaughter," etc.

**T**HE sophisticated daughter of a family whose relations to each other were just remotely and conventionally affectionate is not conscious of being wistful. But when she is plunged, by chance, into the midst of a frank, hearty, openly loving, companionable family group, she awakens to certain things she has been missing. A wonderful summer in camp leaves her with more than memories of lakes, pines, and sunsets.

*Illustrated. Price \$1.75*

At All Bookstores  
Published by

**THE CENTURY CO.**

353 Fourth Avenue  
New York City



## Holeproof Hosiery

Made for grown-ups, too, in silk, silk faced, lusterized listé. At leading stores everywhere in popular spring colorings.

### Times "A Feller Needs Holeproof"

Don't forget to put a couple of pairs of Holeproof in Jimmy's camp kit. They are made to withstand the hard wear that active boys give stockings. Costs so little, too. And saves Mother so much darning.

**HOLEPROOF HOSIERY COMPANY, Milwaukee, Wisconsin**  
Holeproof Hosiery Company of Canada, Limited, London, Ontario

## What the Newspapers are Saying About W. F. Alder's

# "The Isle of Vanishing Men":

"This time it is the out-of-the-way island of New Guinea to which the author takes us in a most delightful book of his experiences. The island is inhabited by cannibals, and while he wished to go there to study the natives, an unexpected shipwreck made it impossible for him to get away. He lived right in the village with the cannibals and learned much about them that has never been told before. Every page of the book is full of interesting and incredible things." — *St. Louis Globe-Democrat*.

"A fascinating and authoritative narrative of New Guinea, one of the few barely-explored sections of the Far East. Mr. Alder has filled the book with photographs which greatly en-

hance its value. He is a very facile and felicitous writer. That he is a man of courage the existence of the book attests." — *Columbus Citizen*.

"A very unusual travel book of a little-known portion of the earth." — *Cincinnati Commercial Tribune*.

"A crisp, brisk record of interesting experiences in a strange land. Its traveler's tales are set down without literary trimming, and in a fashion that will make a lot of folks glad that Brother Alder's journey to 'the interior' did not end in the interior of one of the cannibals that still clutter that isolated part of the earth." — *Worcester Telegram*.

## "THE ISLE OF VANISHING MEN"

is published by

**THE CENTURY CO., 353 Fourth Avenue, New York City**

And is sold at all bookstores.

The price is \$2.00.



*The Philosopher-Vagabond Sees South America*

---



## WORKING NORTH FROM PATAGONIA

By **HARRY A. FRANCK**

*Author of "A Vagabond Journey Around the World," etc.*

**T**HE enormous continent of South America is traversed by Mr. Franck from its extreme south to its northeast corner — from Argentina to Venezuela. He sees the Rio de la Plata and the "turbid Amazon"; the pampas and the "Paris of the South," Buenos Aires; ancient Chile; the upstanding, progressive little republic of Uruguay; Rio, great Brazil, the Guianas and Venezuela.

This is an important and a fascinating addition to Mr. Franck's remarkable group of travel books. They are always welcomed, always popular, but the growing appreciation of the importance to us of understanding South America makes this one even more than usually timely and acceptable. Together with his "Vagabonding Down the Andes," it constitutes a complete picture of South America, physical, social, economic and political. The book has 650 pages and 176 illustrations from photographs taken on the journey by the author himself.

*Price \$5.00*

*By the Same Author*

## VAGABONDING DOWN THE ANDES

**T**HE companion volume to Mr. Franck's "Working North From Patagonia." In this book he tells of his adventures in the land of the Incas as he worked his way along and over the snow-clad Andes. He covers Colombia, Ecuador, Peru, Bolivia, etc.

*Profusely illustrated from photographs. Price \$5.00*

## ROAMING THROUGH THE WEST INDIES

**O**NE of the most delightful books Mr. Franck has written. He makes the reader know Cuba, Porto Rico, the Virgin Islands, Barbados, Santo Domingo, Haiti, Dominica, Jamaica, and many another memorable island asleep in the Caribbean.

*Charmingly and richly illustrated from photographs. Price \$5.00*

---

At All Bookstores  
Published by

**THE CENTURY CO.**

353 Fourth Avenue  
New York City

# A New Serial Story

by Augusta Huiell Seaman



IN this number of ST. NICHOLAS there begins a new serial story by Mrs. Seaman entitled "The Mystery at Number Six." This will be good news, and the beginning of a great treat, for hundreds of ST. NICHOLAS readers, among whom Mrs. Seaman has won a large and ever widening place for herself with her absorbing stories, "The Boarded-up House," "The Crimson Patch," "The Dragon's Secret," — her eager readers can easily fill out the list. "The Mystery at Number Six" promises just as much excitement and sustained interest as the other stories, and it will be a good move on your part to see that your subscription does not expire within the next six months. To miss this new story, as well as Ralph Henry Barbour's "The Turner Twins" and Samuel Scoville's "The Inca Emerald," would be a calamity.

With school-days drawing to a close, you will soon have more time for reading. Be sure that your favorite magazine will spend the vacation with you. And you can have ST. NICHOLAS not only for the summer, but for a whole year — summer, fall, winter, and spring — for \$4. Use this blank form and insure yourself against losing out on a single copy of ST. NICHOLAS.

THE CENTURY CO. } S. N. 6-22  
Concord, N. H., or  
353 Fourth Avenue, New York City.

*Gentlemen:* Please find enclosed \$4, for which send ST. NICHOLAS for one year, beginning with the July number, to

Name .....

Street .....

City..... State.....



# ST. NICHOLAS STAMP PAGE

CONDUCTED BY SAMUEL R. SIMMONS



## NEW ISSUES

FOR several months we have rather neglected this interesting phase of stamp-collecting. Every boy rejoices when he adds one more stamp to his collection, but he takes almost an equal interest in learning about those new stamps which have only recently been issued, and which, he hopes, will some day find a resting-place in his album. While STAMP PAGE has had little to say upon this subject of late, nevertheless, the various countries have gone on, much as ever, issuing stamps and stamps. The change in the water-mark of English Colonies from the "Multiple C A" type to the new "Script C A" has gone on apace. Then there has come upon the market a rather large line of French Colonies in new colors. English Colonies, also, have appeared in bright new colorings. But in most of these instances the design—the old design—has been retained. The new stamps differ from the old ones only in water-marks or color. Neither of these shows in the picture. And what the collector wants most of all is a new design, a novelty easily recognized,—something he can see at once. Perhaps the most interesting item of news about the new issues is the entrance of Ireland into the list of stamp-issuing countries. This much-talked-of country, whose troubles have been told on the first pages of newspapers for so long, is now the owner of a new set of postage-stamps. Perhaps not the proud owner, for this set, while her own, is yet not entirely her own, for it is merely a surcharge upon the stamps of England. Still, it is a surcharge for Ireland, and it is in Gaelic. We illustrate the one-penny red, as the surcharge shows well on that color. Of course, these are only provisionals, and will soon be followed by a series of new designs. Meanwhile, every collector will want at least one stamp of this set. So far, we have seen the English stamps of all values up to and including the ten-shillings. Not only that, but the 2½ d., 4 d., and 9 d., appear with surcharge in both black and red. We

understand those values with black surcharges are already obsolete. ¶Germany has issued a series of stamps devoted to the illustration of forms of labor. Of these, we picture two. First, the one-hundred-pfening, which depicts three miners at work. The one at the left is pushing a car loaded with ore or coal; the tall figure in the center is wielding a pickaxe, while the kneeling figure at the right has a hammer in his left hand and a chisel in his right. The stamp is a yellow-green color. The 150-pfening represents Agriculture. It is orange in color. In the left background a man is sharpening a scythe; the central figure is swinging a scythe against grain in the lower right corner. In the right background is a female figure at work. We also show another type of new German stamps, the central design of which is a "post-horn." This particular value, the 4-mark, is printed in two shades of green, making a striking and rather pleasing effect. ¶Snakes are not common upon stamps. We do not recall any, offhand, except on Mexican stamps. So doubtless those of our readers who make a specialty of animal stamps will be interested in this set of Armenia which we picture. The general design is very neat and pretty. In the circle in the center is a very jovial and happy-looking eagle, bearing in his right talon a heavy sword, while his left talon rests upon the head of a snake whose body has evidently just been cut in two. No wonder that there is such a smile on the face of the eagle! No wonder that he is spreading wide his wings and tail and so evidently rejoicing! It seems inherent in man to rejoice when he has killed a snake; why should not an eagle do so also? But surely these stamps are very attractive indeed, and will add distinction to many a stamp-album. ¶The stamps of Austria are very common and seem to come easily into the hands of the younger collectors. Also, these same stamps seem to give trouble to the novice. So perhaps it is well to show some of the newer types. First there is the

(Concluded on second page following)

## THE ST. NICHOLAS STAMP DIRECTORY

is really a list of reliable Stamp Dealers. These people have studied stamps for years, perhaps they helped your father and mother when they first started their stamp collections. *St. Nicholas* knows that these dealers are trustworthy. When writing to them be sure to give your full name and address, and as reference the name of your parent, or teacher, or employer, whose permission must be obtained first. It is well also to mention *St. Nicholas Magazine*. Remember, we are always glad to assist you, so write to us for any information that will help you solve your stamp problems.

65 Different Foreign Stamps from } including Africa, Asia, Aus-  
65 Different Foreign Countries } tralia, Europe, West Indies  
and our pamphlet, which tells you "How to make your collection of  
stamps properly." For only 16 Cents—A BIG BARGAIN.

Queen City Stamp & Coin Company,  
Room 32 604 Race St., Cincinnati, O.

Stamps 50 all diff., Africa, Brazil, Peru, Cuba,  
Mexico, Ceylon, Java, etc., and Album, 10c. 1000  
Finely Mixed, 40c. 50 diff. U. S., 25c. 1000 hinges,  
10c. Agts. wtd., 50%. List Free. I buy stamps.  
C. Stegman, 5940 Cote Brillante Ave., St. Louis, Mo.



**STAMPS** 50 different Jamaica, Venezuela, etc., only 7c; 1000  
all different, 10c; 1000 all different, \$2.50; 1000  
different U. S. 25c; 1000 hinges, 10c; 50% approvals with every order.  
List Free. I buy stamps.

L. B. DOVER Dept. F. Longmont, Colo.

**BARGAINS** EACH SET 5 CENTS  
4 Iceland; 8 Finland; 20 Sweden; 8 Hondu-  
ras; 8 Costa Rica; 10 Russia; 8 Dutch Indies; 4 Siam. Lists of 7000  
low-priced stamps free.  
CHAMBERS STAMP CO., 111 G NASSAU STREET, NEW YORK CITY

**FREE** Packet of desirable stamps, exceptional  
quality to approval applicants furnishing  
satisfactory references.  
H. C. ARGENTBRIGHT, Box 352, Staunton, Va.

**STAMPS—20 VARIETIES, UNUSED, FREE** to all send-  
ing for our approval sheets at 50% discount. Postage 2 cents.  
Mention *St. Nicholas*. QUAKER STAMP CO., TOLEDO, OHIO.

**FREE** 2 GERMAN AEROPLANE STAMPS  
to approval applicants. Reference required.  
J. R. NICHOLS, 2322 Loring Pl., New York City.

**DANDY PACKET STAMPS** free for name, address 3 col-  
lectors, 2c postage, with 50% apprs. 125 dif.  
U. S. inc. high values, 50c. U. T. K. STAMP CO., UTICA, N. Y.

**Stamps Free** Fine set War Stamps, Surcharged, Unused, Pic-  
torials, British, French Col's with Big PRICE LIST.  
2c postage. MIDLAND STAMP CO., Toronto, Canada.

**FRENCH COLONIES FREE**—Set Used and Unused Pic-  
tures, Wild Animals, Native Chiefs, Scenery and big bargain  
List. 2c postage. EMPIRE STAMP CO., Toronto, Canada.

**WORLD'S LARGEST** Wholesale and Retail Catalogue of  
Postage Stamps now ready. 128 pages.  
Single stamps, sets, packets, albums, mixtures, supplies, etc.  
Price 10 cents. Worth \$5 to you. Send 10 cents today.  
**Bargain Sets** We offer these great bargains at low prices. No two  
stamps alike in any set. All fine. 50 Africa 24c; 15  
Arg. Rep. 11c; 50 Asia 17c; 35 Austria 10c; 35 Bavaria 20c; 10 Brazil  
5c; 100 Br. Col's 29c; 25 Bulgaria 25c; 20 Chile 11c; 10 China 7c; 50  
Cuba 49c; 10 Czecho's 12c; 10 Egypt 7c; 7 Iceland 20c; 50 Italy 19c;  
40 Japan 7c; 8 Liberia 25c; 17 Mexico 10c; 33 Nyassa 45c; 10 Paraguay  
10c; 25 Persia 25c; 6 Reunion 5c; 20 Russia 10c; 7 Siam 15c; 10 Straits  
7c; 30 Sweden 11c; 100 U. S. 20c; 10 Uruguay 8c; 50 French Col's 34c;  
50 Portuguese Col's 35c. Following wonderful collections guaran-  
teed to satisfy or your money back: 1000 varieties \$2.90; 1500 varieties  
\$5.45; 2000 varieties \$8.90. Postage extra. Remit in stamps or money  
order. We buy stamps. MARKS STAMP CO., Dep't N, TORONTO, CANADA.

## Here's a Rare Chance

**FREE** 24 Page Illustrated Book "The Stamp Collector's  
Guide." With packet No. 60—150 all diff. for  
25c—or packet No. 244—50 diff. Africa, 50c. If your  
stationer or bookseller doesn't sell Scott Stamp packets ask  
him to write us.

SCOTT STAMP & COIN CO.

33 West 44th Street

New York City



## 158 Genuine Foreign Stamps

Mexico War issues, Venezuela, Salvador and  
India Service, Guatemala, China, etc. Only  
Finest Approval Sheets 50 to 60c. Agents Wanted. Big  
72-page Lists Free. We buy stamps. Estab. 29 yrs.  
Hussman Stamp Co., Dept. 52, St. Louis, Mo.



SUDDEN  
SERVICE

## TRIANGLE

Scarce FIUME (like illustration),  
also 50 other different stamps, China  
ship set, large \$1.00 U. S. reve-  
nue; millimetre scale, ruler and All For  
perforation gauge. Bargain lists  
and 50 to 60% approvals with every  
order. FENNELL STAMP CO.,  
Dept. S. Fullerton Bldg., St. Louis, Mo.

9c



**65c for 8c.** Abyssinian stamp, Guatemala  
Parrot stamp, Packet 30 vari-  
eties British Colonies, cat. 65c. Packet Hinges. Large  
mm. scale, perf. gauge and wmk. detector. Price list  
and finest 50% approvals all for 8c. WE BUY STAMPS.

ALLEN SEARS, Inc.

Dept. S, Suite 508 Kemper Bldg., Kansas City, Missouri.

**200** diff. Stamps 18c; 100, 9c. 20 Persia 20c, Hinges 1000, 12c.  
Lists Free. MICHAELS, 5602 Prairie, Chicago.

**QUICK SERVICE!** When you want stamps you want 'em  
quick. And I have just the kind you  
want; clean, well arranged up to date approval selections at 50%  
disc. with extra discounts for prompt returns. The general collector  
will be delighted. Try them and you will say "How does he do it?"  
D. M. WARD, 608 Buchanan St., Gary, Ind.

P. S. 3 Aguinaldo Philippine Stamps free to approval applicants.

**FOREIGN STAMPS FREE**—Big Variety Packet Foreign  
Stamps from all over the World. 2c postage.  
GRAY STAMP CO., Station E., Toronto, Canada.

(Continued on next page)



**STAMPS**—(Continued from preceding page)

**STAMPS** 105 China, etc., stamp dictionary, list 3000 bargains, 2c. Album (500 pictures), 3c. **BULLARD & Co., Sta. A, Boston.**

**FREE** List of sets and approvals. **HUB POSTAGE STAMP Co., Inc., 345 Washington Street, Boston, Mass.**

**FREE** 7 beautiful French Colonials, to approval applicants. **FRANK HADLEY, Box 73, Plainfield, N. J.**

**Fine Stamps** on approval, reference required. **WICKWEL STAMP Co., Springfield, Mass.**

**100** VARIETIES HUNGARY AND BIG LISTS. **18c**  
**JOHN M. LONG, 67 Public Sq., Watertown, N. Y.**

**20** different BRITISH COLONIAL stamps **10c**  
**R. H. A. GREEN, 821 Main St., Evanston, Ill.**

**ZANZIBAR.** 3 different, 6c.  
**A. C. DOUGLAS, A. S. D. A., LUCAN, ONT.**

**FREE** Packet of fine stamps for names and addresses 2 live collectors, and 2 cents postage.  
**HIAWATHA STAMP SHOP, Syracuse, N. Y.**

**ALL FOR 10c** 20 Diff. Stamps from 20 Diff. Countries.  
 10 Unused and 2 Malay States (Tigers).  
**FOYE STAMP COMPANY - Detroit, Michigan**

**FREE** 10 Scandinavian, millimetre scale, gauge, book, lists, etc., to all sending 10c for 57 diff. Siam, Ceylon, Guatemala, etc., 200 diff. 25c, 300 diff. 75c., 100 diff. U. S. 25c.  
**HAWKEYE STAMP Co., Cedar Rapids, 49, Iowa.**

**Largest Stamp** ever issued by Jamaica. Free with selection of my one- and two-cent approvals.  
**H. E. CODWISE, MELROSE HLDS., MASS.**

**25** Gold Coast, Newfoundland, India, etc. **FREE** with trial approval sheets. 500 different stamps 90c; 1000 all different \$2.25. Hinges 10c per M. **F. J. STANTON, Norwich, N. Y.**

**ST. NICHOLAS STAMP PAGE**

(Concluded from second preceding page)

7½-kronen of the "Eagle" type, with the word "Deutschosterreich" at the top. The 5-kr. and 25-kr. show two types of the adhesive stamps; the 75-heller, with head of Mercury turned to the left, is the latest type of newspaper stamp; while the one with arrow and post-horn is perhaps special delivery or airplane. But notice that the name of the country at the top is now only "Osterreich"; from this issue the "Deutsch" is omitted.



**THE CATALOGUE**

**O**UR mail of late has had an unusually large number of questions about "The Catalogue." This is an annual publication and is sold by practically every stamp-dealer in the United States. It lists and prices all postage-stamps that have been issued up to date of publication, both United States and foreign. Moreover, all foreign stamps are illustrated. Under each country in sequence of time is given a list of all its stamps noting the dates, the value and color of the stamp, its price both used and unused. Each major variety is given a number for purposes of reference, so that if you should mention to any dealer in the United States "Austria, Scott No. 110," he would know exactly which stamp of Austria you had in mind.

**FREE:** Dandy packet containing Liberia and Fiume Triangles, Siam, Ukraine, etc. to approval applicants and 2c stamp. 575 Diff. stamps 95c. **S. GROSSMAN Co., 1568 First Ave., N. Y. City.**

Stamp saving is a fascinating game. Join the **ST. NICHOLAS STAMP CLUB** and enjoy its benefits and fun. We will send you a membership blank, if you ask for it.

**Press Comments On**

**MYSTIC ISLES OF THE SOUTH SEAS**

**By FREDERICK O'BRIEN**

Author of "White Shadows in the South Seas"

**O**BRIEN'S book is not mere description, and his glamor is not the old glamor of picturesque romance. Consciously and unconsciously, but more often consciously, he presents in this easy-flowing, almost too discursive narrative of life with a nature people a new defence of the primitive in man and an attack upon industrial civilization. . . . This is a story by one of those rare men who really try to understand their environment, and who, when they go abroad, live the life of which they write."—*New York Evening Post.*

"Frederick O'Brien, incomparable story teller, has spread a magic carpet of adventure and romance, and we who come daily into this murky atmosphere of soot and grime may clasp its sunshine for our very own. . . . It is the chronicle of a clear-seeing, sympathetic, thoroughly human American male through whose veins runs a love for things odd, colorful, mysterious."—*Chicago Daily News.*

"A joy to read, and re-read. Every now and then the thumb digs into the margin to mark a gem to be used in tempting others."—*Oakland Tribune.*

**["Mystic Isles of the South Seas" is published by The Century Co., 353 Fourth Avenue, New York City, and is sold at all bookstores for \$5.00]**

# BOYS!!

Here's your chance to get the five-volume Memorial Edition of Charles E. Van Loan's sport stories—one of the greatest collections ever written—and a year's subscription to **THE AMERICAN GOLFER**, **THE SPORT PICTORIAL**—at greatly reduced rates.

Mr. Van Loan's stories are unique in the field of sports—each a complete narrative, full of humor and the spirit of true sportsmanship. There are forty-nine of them in all, comprising tales of golf, boxing, baseball, racing and moving-pictures.

The books are well bound and printed on gilt-edge paper. They originally sold for \$25.

**THE AMERICAN GOLFER**, **THE SPORT PICTORIAL** — edited by Grantland Rice, is one of the most popular and well known sports magazines of the present day. It carries news of the latest happenings in the world of sport, and is fully illustrated throughout. It is issued every other Saturday. The subscription price is \$5.

The sum of \$10 will bring both of these fine publications to your home, a saving of two thirds of the usual price.

Tell Dad about this—he might want a chance at the bargain too. There are only a few sets of the Van Loan books left, so cut out the coupon below and send it to us right away.

CENTURION PUBLISHERS, INC.  
353 Fourth Avenue, New York City

Enclosed find \$10.00, for which send me **THE AMERICAN GOLFER**, **THE SPORT PICTORIAL**, for one year (26 issues); and the 5-volume Memorial Edition, boxed and express paid.

*Magazines and books  
may, if desired, be sent  
to separate addresses.*

NAME .....

ADDRESS .....

.....

*Postage in Canada, 50 cents; foreign countries, \$1.00.*





“AD”  
VENTURES of the

IVORY HEROES



**WOE  
BE-GOBBLE  
TOWN.**  
Chapter  
VI.

believe was true. They saw a host of women who did naught but work all day; they had to rub, and scour, and scrub, with never time to play. They were the slaves of furniture, of windows, and of doors; of woodwork and linoleum; of soiled and streaky floors. Their fine mahogany was dulled by films of hazy blue; white paint was finger-marked, and all their windows smudgy, too.



**S**TRAIGHT as a hurried eagle flies before a driving gale, on sailed your IVORY bubble with the heroes of this tale. Then with a plunge and diving dip the bubble hurtled down upon a most distressful spot called *Woe-be-gobble Town*.

Our little heroes gazed with pain and sadsome sorrow, too, upon a sight their merry eyes could scarce believe

the weary mothers raised their heads.



These mothers were so weary and absorbed in cleaning trouble, they hardly saw our heroes or the lovely IVORY bubble. Our heroes had not come to gaze on trouble, empty-handed, so they began to IVORY-ize the moment that they landed. Gnif cleaned the windows as he said:

“A fight with dirt is won, when IVORY SOAP lets in the light of dirt-destroying sun. Bob cleaned the spotted woodwork, and our Betty scrubbed each floor, as Yow and Snip kept bringing cakes of IVORY by the score.

The weary mothers raised their heads; their eyes gleamed bright with hope at seeing all the wonders worked by snowy IVORY SOAP. Soon *Woe-be-gobble Town* was clean; the mothers were delighted. They said:

“We see that IVORY our wrongs have fully righted.” And as our heroes sailed away a book dropped from a rope, entitled, “*Ways Unusual For Using IVORY SOAP.*”

*That book was good as its good name,  
So you had better get it.  
Just ask Miss Betty IVORY,  
And you will not regret it.*

Don't you want to see how and when these marvelous adventures began? Then write to your friends, The Procter & Gamble Co., Cincinnati, Ohio, asking for a little book called “THE CRUISE OF THE IVORY SHIP,” by John Martin. It is a wonderful little bedtime book, given *FREE* to you.



**IVORY**  **SOAP**  
IT FLOATS 99 <sup>44</sup>/<sub>100</sub> PURE



*They are not Keds unless the name Keds is on the shoe*



*Heavy white or brown canvas; strong reinforcements and ankle patch. The boys' favorite in the Keds line.*



*One of the most popular all-purpose Keds. Comes also in a low model. For boys and girls and grown-ups.*

## Shoes like the paws of a grizzly bear

In spite of his size, the Rocky Mountain grizzly can jump, climb, and run with surprising speed.

With a pair of Keds, you make your feet almost like the grizzly's thick springy paws.

Keds are built to give your foot the fullest development that the human foot is capable of.

The soles are thick and springy, light enough for speed, with plenty of strength for wear and to protect the feet on rough ground.

The pliable canvas tops are light weight and cool in hot weather, but tough and strong to stand hard knocks. Sturdy reinforcements are added to strengthen the shoes where extra wear comes.

With Keds like these the muscles of your feet grow stronger and develop naturally. You will find that you can run faster, walk further and grow more skilful

in every game and sport. Wear Keds just as much as you can from early in the spring until late in the fall.

### *Why you should insist on Keds*

There are many models, high Keds, low Keds, brown Keds, black Keds, and white. Any kind of sole you want—suction, corrugated or smooth. If your dealer doesn't carry the kind you want he will get them for you.

But remember, Keds are made only by the United States Rubber Company, the largest and oldest rubber organization in the world. If the name Keds isn't on the shoes, they aren't real Keds.

Booklet, "Camping" sent free if you write to Dept. D-3, 1790 Broadway, New York City.

**United States Rubber Company**

# Keds

Trademark Reg. U. S. Pat. Off.



*Keds were originated and are made only by the United States Rubber Company. The name Keds is on every pair. It is your guarantee of quality and value.*





Peter Piper picked a pack of Pep-O-Mints,  
A piquant pack of Pep-O-Mints Peter Piper picked;  
Pete was piqued at pickles,  
Said he, "I'll spend my nickels  
For the candy mint that tickles."

Pep-O-mint  
Wint-O-green  
Lic-O-rice  
Cl-O-ve  
Cinn-O-mon



JULY 1922

# ST. NICHOLAS



THE CENTURY CO

353 FOURTH AVENUE NEW YORK

THE CENTURY AND ST.



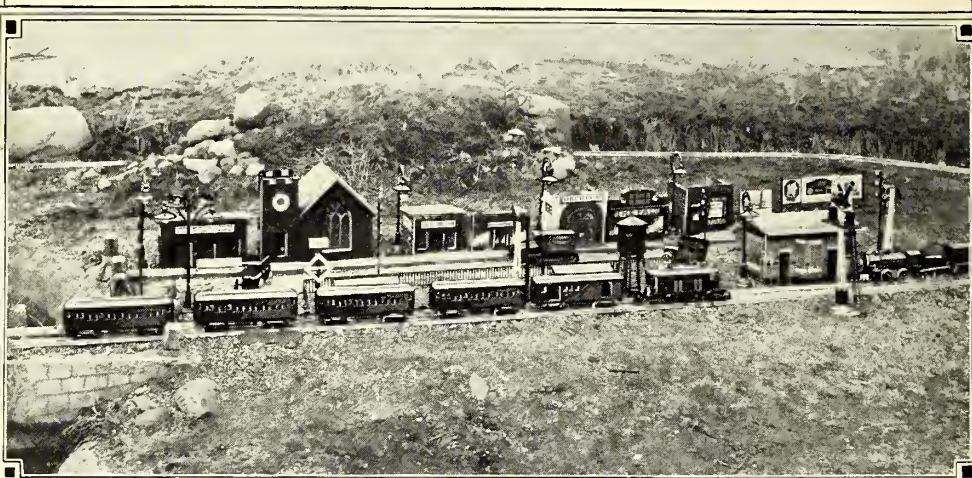

## Build an "AMERICAN FLYER" Backyard Railroad

There's lots of fun in operating your miniature electric or mechanical railroad outdoors. You can get extra track and equipment from your dealer. Build tunnels, bridges and solve all the problems of railroading.

### *Big Prize Contest*

\$100 in cash prizes. Send us photos of the railroad you build. Every one gets an Engineer's Cap and 50 cents worth of equipment. Write for further particulars and booklet "How to Build a Backyard railroad. Use any equipment.

AMERICAN FLYER MFG. CO.  
2219 South Halsted Street CHICAGO

*American Flyer*



# What is the matter with your hair?



Falling?

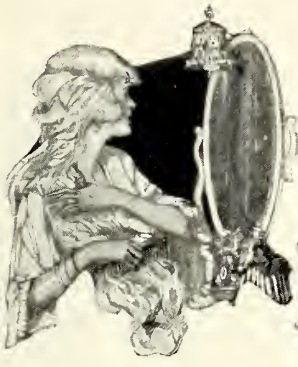

Dandruff?



Oily?



Dull?

## How to have beautiful hair when you grow up

**M**AIL the coupon today for trial size bottle of Palmolive Shampoo and an interesting book on hair treatment which we send with it.

The booklet will tell you how to take care of your hair now so that it will be beautiful when you grow up.

Trial size bottle of this Shampoo introduces you to the most healthful of all hair cleansers.

This bottle is ample size and if you are still wearing your hair bobbed you will find it contains enough for several washings.

Read the booklet first and then use Palmolive Shampoo according to instructions. You will find it so easy and pleasant that you will never mind washing your hair again.

### Makes shampooing fun

How you will enjoy rubbing up a rich, creamy Palmolive lather until it envelops your head like a clean-smelling sudsy cap!

How quickly this lather will dissolve all dirt and oiliness — how quickly and easily it rinses out, taking all soil with it!

How soft and fluffy your hair will be after it is dry — how beautifully glossy you will find it after you brush it out.

Palmolive Shampoo is a beautifying shampoo and a health shampoo, and also the easy, quick shampoo, making you actually like to wash your hair.

Ask for the free trial bottle now and prove all this for yourself. Just fill out the coupon and mail it today.

THE PALMOLIVE COMPANY  
Milwaukee, U. S. A.

### New booklet free



Be sure and send for this new booklet on the care of the hair, which explains authorized scientific hair treatment, supplied by leading specialists

# PALMOLIVE SHAMPOO

Copyright 1922—The Palmolive Company 1626



### Trial Hair Treatment Free

THE PALMOLIVE COMPANY  
Dept. B-341, Milwaukee, U.S.A.

Please send me the trial hair treatment and free booklet, "How to Take Care of the Hair."

Name.....

Address.....



(The entire contents of this Magazine are covered by the general copyright, and articles must not be reprinted without special permission.)

## CONTENTS OF ST. NICHOLAS FOR JULY, 1922

<b>Frontispiece: "I see you 're a little rebel," he said.</b>		Drawn by Oscar F. Schmidt.
<b>How the American Army Was Saved by a Dinner and a Song.</b>	Story	Ellen D. Wangner . . . . . 899
Illustrated by John Wolcott Adams		
<b>The Pinch-Quitter.</b>	Story. Illustrated by C. M. Relyea . . . . .	William T. Tilden, 2nd. . . . . 905
<b>The Pot o' Magic.</b>	Story. Illustrated by Dudley Gloyne Summers . . . . .	Grace Jewett Austin . . . . . 913
<b>Fortune.</b>	Verse . . . . .	Mary Carolyn Davies . . . . . 917
<b>Guardian of Uncle Sam's Forests.</b>	Sketch	
Illustration from photograph		
<b>A Strand of White Horsehair.</b>	Story . . . . .	Wallace Hutchinson . . . . . 918
Illustrated by Enos B. Comstock		
<b>The Coverlid.</b>	Story. Illustrated by Oscar F. Schmidt . . . . .	Mary Wells . . . . . 922
<b>Up-to-Date.</b>	Picture. Drawn by A. B. Walker . . . . .	. . . . . 935
<b>The Mystery at Number Six.</b>	Serial Story . . . . .	Augusta Huiell Seaman . . . . . 928
Illustrated by W. P. Couse		
<b>Government-Owned Buildings—Which Owns Which?</b>	Sketch . . . . .	C. Mitchell Tallaferro . . . . . 936
Illustrations from photographs		
<b>The Campanile.</b>	Verse. Illustration from photograph . . . . .	Kathryn Hulbert . . . . . 939
<b>How Boys Play Games by Radio.</b>	Sketch. Illustration from photographs . . . . .	William Telher . . . . . 940
<b>Drake.</b>	Ballad. Illustrated by W. M. Berger . . . . .	Katharine Lee Bates . . . . . 942
<b>A Visit to Drake's Bay.</b>	Sketch. Illustration from photograph . . . . .	J. Smeaton Chase . . . . . 946
<b>The Turner Twins.</b>	Serial Story. Illustrated by C. M. Relyea . . . . .	Ralph Henry Barbour . . . . . 947
<b>United States—An Acrostic.</b>	Verse . . . . .	Kitty Parsons . . . . . 954
<b>The Washington Elm.</b>	Sketch. Illustrations from photographs . . . . .	William H. Bertenshaw . . . . . 955
<b>The Destroyers.</b>	Sketch. Illustrated by Paul Spener Johst and from photograph . . . . .	Archibald Douglas Turnbull . . . . . 956
<b>The Hill of Adventure.</b>	Serial Story. Illustrated by J. Clinton Shepherd . . . . .	Adair Aldon . . . . . 961
<b>Wonder Thoughts.</b>	Verse . . . . .	Faith Van V. Vilas . . . . . 967
<b>Good News—The Grateful Bunnies.</b>	Verse . . . . .	Arthur Guiterman . . . . . 968
Illustrated by Reginald Birch		
<b>The Last Laugh.</b>	Story. Illustrated by George Varian . . . . .	Harry Starkey Aldrich . . . . . 969
<b>Almost a Muff.</b>	Pictures. Drawn by Charles F. Lester . . . . .	. . . . . 976
<b>The Inca Emerald.</b>	Serial Story. Illustrated by Charles Livingston Bull . . . . .	Samuel Scoville, Jr. . . . . 977
<b>How the Declaration of Independence Was First Made Known to the Public.</b>	Sketch. Illustrations from prints . . . . .	Gardner Teall . . . . . 983
<b>A Vagabond Bee.</b>	Verse . . . . .	Clinton Scollard . . . . . 986
<b>The Watch Tower.</b>	A Review of Current Events. Illustrated . . . . .	Edward N. Teall . . . . . 987
<b>Nature and Science for Young Folk.</b>	Illustrated . . . . .	. . . . . 992
Making Thunderbolts to Order (M. Tevis)—The Columbine's Joke (George A. King)—Insects to Fight Pests (H. E. Zimmerman)—The Black-hull Wheat (Keith J. Fanshier)—Which is the Coolest Hat? (S. Leonard Bastin)—A Traveling Outfit for Surveyors (L. M. Edholm).		
<b>For Very Little Folk:</b>		
<b>A July Jingle.</b>	Verse. Illustrated by Reginald Birch . . . . .	Ellen Manly . . . . . 996
<b>The St. Nicholas League.</b>	With Awards of Prizes for Stories, Poems, Drawings, Photographs, and Puzzles. Illustrated . . . . .	. . . . . 998
<b>The Letter-Box . . . . .</b>		. . . . . 1006
<b>The Riddle-Box . . . . .</b>		. . . . . 1007
<b>The St. Nicholas Stamp Page.</b>	Conducted by Samuel R. Simmons . . . . .	Advertising Pages

*The Century Co. and its editors receive manuscripts and art material, submitted for publication, only on the understanding that they shall not be responsible for loss or injury thereto while in their possession or in transit. Copies of manuscripts should be retained by the authors.*

In the United States, the price of ST. NICHOLAS MAGAZINE is \$4.00 a year in advance, or 35 cents a single copy; the price of a yearly subscription to a Canadian address is \$4.35. The price of a yearly subscription to a foreign address is \$4.60. We request that remittances be by money-order, bank check, draft, or registered letter. The Century Co. reserves the right to suspend any subscription taken contrary to its selling terms, and to refund the unexpired credit. PUBLISHED MONTHLY.

The half-yearly parts of ST. NICHOLAS end with the October and April numbers respectively, and the red cloth covers are ready with the issue of these numbers; price \$1.00 by mail, postpaid; the two covers for the complete volume, \$2.00. We bind and furnish covers for \$2.00 per part, or \$4.00 for the complete volume. (Carriage extra.) All copies of this magazine which are to be bound must be sent to our New York office. In sending the numbers to us, they should be *distinctly* marked with owner's name. Bound volumes are not exchanged for numbers.

All subscriptions for, and all business matters in connection with, ST. NICHOLAS MAGAZINE should be addressed to

### THE CENTURY CO.

Publication and Circulation Office, Concord, N. H.

Editorial and Advertising Offices, 353 Fourth Ave., New York, N. Y.

W. MORGAN SHUSTER, *President*  
DON M. PARKER, *Secretary*

GEORGE L. WHEELOCK, *Treasurer*  
JAMES ABBOTT, *Ass't Treasurer*

#### BOARD OF TRUSTEES

VOL. XLIX.

GEORGE H. HAZEN, *Chairman*

W. MORGAN SHUSTER

No. 9

(Copyright, 1922, by The Century Co.)

(Title Registered U. S. Pat. Off.)

(Printed in U. S. A., and Entered as Second Class Matter, September 4, 1920, at the United States Post Office, Concord, N. H., under the Act of March 3, 1879. Entered at the Post Office Department, Ottawa, Canada.)

"We are advertised by our loving friends"



Ruth M. Greene, Bowling Green, Ky.

# Mellin's Food

When you think of Mellin's Food, picture in your mind healthy babies, as the two naturally go together. Mellin's Food and fresh cow's milk is just the diet a baby needs to thrive and develop, as Nature intended.

*Send today for a copy of our book, "The Care and Feeding of Infants."*

Mellin's Food Company,

Boston, Mass.



# ST. NICHOLAS

## NEXT MONTH AND TO COME

### In the Wake of the Hurricane

CHARLES TENNEY JACKSON

This thrilling story tells how two boys and a French trapper saved an entire colony of fisher folk after a devastating West Indian storm. W. P. Couse has made some splendid illustrations for it, too.

### Splash!

GEORGE H. CORSAN

Do you know how to swim? It does n't require an ocean in which to learn. In this article, Mr. Corsan, famous swimming instructor, points out how one may become proficient, even in a home-made swimming pool. A timely article, and a helpful one.

### In the Blood

KENNETH PAYSON KEMPTON

Those readers of ST. NICHOLAS who remember the exciting incidents of "Phantom Gold," which appeared serially in the magazine last year, will welcome this two-part sea story by the same author.

### The Key

BETH B. GILCHRIST

And here is another serial contributor of last year appearing with a short story this season. A short story, but a very good one, and you'll be interested in *Beverly* and her gardener, *Dick*.

### Outraging Stanford Tradition

A. MAY HOLADAY

Another college story, true to life in setting and slang, and with a humorous twist that will please you immensely.

---

The August number will be particularly rich pictorially, and will also have an extra measure of stories for vacation reading. In addition to the above list and instalments of three serials, there will be notable short stories, "The Hide-y Hole," and "The King of the Turquoise Mountains," and articles by Hildegard Hawthorne and Francis B. Atkinson.

# *A Book for the Wireless Boy*

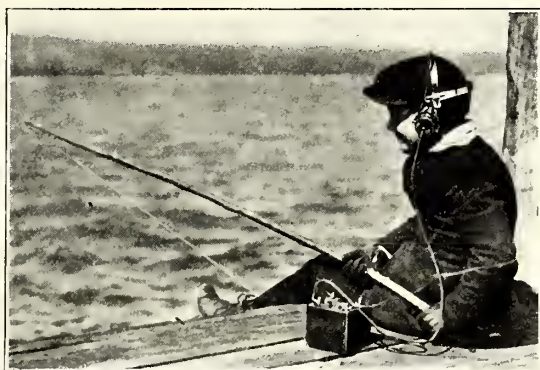

## THE COMPLETE RADIO BOOK

By Raymond Francis Yates and L. G. Pacent

**H**ERE, at last is all about radio that is known today within the covers of one book. It will make the boy who owns it a junior radio expert; make radio a big and splendid piece of education, and more exciting than ever. Besides the story of just what radio is and how it works, and the magical things it does, this book tells exactly how to do everything the radio amateur wants to do — how to overcome trouble, what is the best apparatus for any purpose, etc. There are twenty-five diagrams and forty illustrations showing radio at work. It is written in a fascinating, popular style by two leading radio experts.

**R. F. Yates** is radio editor of "The New York Evening Mail" and editor emeritus of "Popular Science Monthly."

**L. G. Pacent** is one of the best-known radio engineers and is the head of a business manufacturing his own radio inventions.

*They Know It*  
*They Know How To Tell It*  
**\$2.00**

At All Bookstores  
Published by

**THE CENTURY CO.**

353 Fourth Avenue  
New York City



Dear Father,

School closes next week for the summer. It will be fine to see you and mother again. I suppose Sister will be home then too.

This letter is not to talk about vacation but about the wonderful school year that has just finished. There has been no end of fun, and hard work too. The headmaster and teachers have been the sort of men that make a fellow feel like doing his best.

You remember last year when we were deciding about my school, what a talk we had. You were surprised that my ideas of a school were so definite. Still you listened and were wise enough to let me justify myself. That is one of the reasons why this school year has been so successful.

A boy or girl should be allowed to help select the school. Then they can <sup>bring</sup> carry their enthusiasms, their desires, their feeling of not being forced.

When the child feels that he is simply being sent away to school because his parents have used only their own desires in its selection, he is apt to go without that wonderful enthusiasm which means so much for a happy year.

Of course, parents have the final decision to make but when the child's likes or dislikes are considered before the decision is made, the chances are bright that the student is going to have a very much more successful year than otherwise ..... school masters and parents, too.

Love to mother and yourself -

Worald

June 15, 1922.

# GOOD SCHOOLS

— FOR —  
BOYS *and* GIRLS

## WILLISTON

### JUNIOR SCHOOL

*For Young Boys*

Organized to develop the entire boy. Thorough work and graded athletics. Prepares for all leading preparatory schools. Home care, under House-mother, Head-master, and Special Faculty.

*Rate \$700*

Senior School prepares for college and scientific schools. A progressive school with 80 years of solid achievement behind it.

ARCHIBALD V. GALBRAITH, Principal  
Box N, Easthampton, Mass.



## Southfield Point Hall

A School for Girls. Beautifully situated on Long Island Sound at Southfield Point. Intermediate, general, and college preparatory courses. Music, gymnastics, athletics, and sports. Horseback riding, skating, Skiing. 52 Minutes from Grand Central Station, New York. Limited enrollment.

JESSIE CALLAM GRAY, B.A., Principal  
BERNICE TOWNSEND PORTER, Assistant Principal  
10 Davenport Drive, Stamford, Conn.



PENNSYLVANIA, Swarthmore.

**THE MARY LYON SCHOOL** A Country School in a College Town  
Preparatory for college. High scholastic standards. Music, Art, Languages, Home-making Sciences. Outdoor sports including canoeing  
SEVEN GABLES—Junior School. WILDLIFF—Graduate School. Write for catalogs.  
MR. and MRS. H. M. CRIST, Principals,  
Box 1542, Swarthmore, Pa.

## COLUMBIA PREPARATORY



### SCHOOL

BOYS      GIRLS



Preparation for all Colleges and Universities. Sponsored by University Presidents. Patronized by University faculties. Member University of State of New York.

**Day and Resident—Primary to College**

*Combining the most progressive methods of education with the cultural advantages of New York*

Ideal home life for refined, cultured girls and boys of all ages, under an experienced faculty composed of Europe's and America's most eminent teachers, who are masters in social and academic training. Separate departments for Art, Music, Dramatic Art and Junior Divisions.

DR. S. N. CLAWSON, Principal  
301 W. 88th Street, Cor. West End Avenue  
New York

MASSACHUSETTS, Berkshire.

**CRESTALBAN** A school for little girls in the invigorating climate of the Berkshires. Thirty minutes from Pittsfield. 200 acres, 3 buildings. Number limited. Special care given to home training, character development, and health. Open-air classes. Outdoor sports.  
MISS MARGERY WHITING, Principal.



# TENACRE

*A Country School for Young Girls  
from Ten to Fourteen Years of Age*

**P**REPARATORY to Dana Hall.  
Fourteen miles from Boston. All  
sports and athletics supervised and  
adapted to the age of the pupil. The  
finest instruction, care and influence.

MISS HELEN TEMPLE COOKE  
Dana Hall, Wellesley, Mass.



*Riding  
Class at  
TENACRE*

## Miss Hall's

SCHOOL FOR GIRLS

In the Berkshire Hills, on  
the Holmes Road to Lenox.  
Forty-five acres. One thou-  
sand feet above the sea level.

Miss MIRA H. HALL, Principal  
Pittsfield, Massachusetts



## The Castle

Junior Department of Miss Mason's School  
For the little girl who wants a school like older  
sisters. Work and play directed for the steady  
development of the child from 6 - 12 years of age.  
Unsurpassed advantages. Near New York City.  
Rate \$1000. Catalog.

Miss C. E. MASON, Principal  
Box 725, Tarrytown-on-Hudson, N. Y.



## Ossining School

FOR GIRLS

We offer, with diploma, Academic, College  
Preparatory, Art, Music, Dramatic, Secretarial  
and Home-making Courses, including Horti-  
culture.

Students may enter regular courses or, with  
parents' approval, may specialize as desired. In  
beautiful Westchester, 30 miles from New York.  
54th year. Write for Year Book. Address  
Ossining-on-Hudson, New York. Box 7N.

CLARA C. FULLER, Principal



## Lincoln School

A school for girls, offering country life with the advantages  
of the city. Preparation for college examinations, and  
general courses. Exceptional opportunity for outdoor  
sports. Horseback riding.

Miss Miriam Sewall Converse, Principal  
Providence, Rhode Island

# BINGHAM SCHOOL, MEBANE, N. C.

ESTABLISHED 1793

AN IDEAL BOYS SCHOOL IN PIEDMONT NORTH CAROLINA

Military organization, begun in 1861. High moral tone. Lovely lawns. Gymnasium. Athletic  
park. Bible and Physical culture emphasized. Honor System. Celebrated climate. Outdoor classes.  
Limited numbers. Sports in variety. 340 acres. Summer camp. A modern school with an  
ancient name, fame and history. Send for catalogue.

COL. PRESTON LEWIS GRAY, President, Box 8, Mebane, N. C.



# Whiting Hall

## A Country Home School for Girls

from eight to sixteen, affiliated with the best preparatory schools. Twenty-six acres, modern buildings, new gymnasium, ideal location, high elevation — halfway between Boston and Worcester, near Longfellow's Wayside Inn. Outdoor sleeping and class rooms, if desired. Individual care. Teachers for all branches. Mistress of field games. House mother. Family life emphasized. Tenth year.

MR. ELBRIDGE C. WHITING, Amherst, Yale, MRS. WHITING, Wellesley, Prins. CONCORD ROAD, SOUTH SUDBURY, MASS.



## Starrett School for Girls

Thirty-seventh year. Academic, college preparatory and special courses; also seventh and eighth grammar grades. Co-operative with the University of Chicago; prepares for Smith, Wellesley and Vassar Colleges. Member of the North Central Association. Full courses in all subjects offered by the best academic schools. European Trip — Summer 1923 — Credit given in History and Art. Exceptional advantages in Music and Art. A home school in elegant fire-proof building two blocks from Lake Front Park, Tennis Courts and Bathing Beach. Fall term begins Sept. 14.

Address Registrar, Box 28  
4932 Lake Park Ave., Chicago, Ill.



## RYDAL Junior Department of the Ogontz School

A fifteen acre private estate on the Rydal Hills is the home of the Rydal School, for girls 9-14 years. Same management as Ogontz School, but a separate school in buildings, faculty, work and play. Parents will find at Rydal the same unusual opportunities that make the Ogontz School distinctive. Teacher of strong personality and experience in charge. Enrollment limited. Visit the school or write for book of views and "Letter to Mothers." Address  
Miss Abby A. Sutherland, Rydal, Montgomery Co., Pa.

## The Hedges

NORTON, MASS.

The Junior School of **House in the Pines**. 30 Miles from Boston. For girls under fourteen. A large modern home. Sun parlors for class rooms. Play fields. Horseback riding. Swimming. A wholesome, simple life of study and play that makes the child quick to feel, eager to know, able to do.

MISS GERTRUDE E. CORNISH, *Principal*



## Junior Bradford

Prepares for Bradford Academy, having the benefits of its splendid equipment, intellectual and social activities, and athletic grounds. Gymnasium. Swimming pool. Separate building. Girls from the fifth grammar grade up accepted. Healthful mental and physical development under especially trained instructors. Address

The Principal, Bradford, Mass.

## CONNECTICUT, Cornwall. RUMSEY HALL

A School for Boys under 15. Yearly rate \$1300.

L. R. SANFORD, *Principal*.  
LOUIS H. SCHUTTE, M.A., *Headmaster*.

250 Boys 22 Men

\$800,000 Equipment

89th year opens September 19th

# WORCESTER ACADEMY

WORCESTER MASSACHUSETTS

Rates: \$1000 single  
\$850 double

Junior School for young boys

For catalog address the  
Registrar, G. D. Church, M.A.

SAMUEL F. HOLMES, M.A., *Principal*

## Woodland Park

Junior School for Lasell Seminary

Prepares for Lasell Seminary and other leading secondary schools. Careful direction under House Mother. Progressive methods of study and play. All the equipment of Lasell Seminary, with playgrounds, gymnasium and swimming pool. 15 Buildings. 30 Acres.  
Camp Tecomet opens July 1.

Guy M. Winslow, Ph.D.,  
*Principal*. Chas. F. Towne,  
A. M., *Associate Principal*.  
Woodland Road, Auburndale,  
Mass.

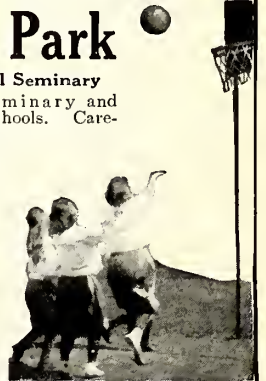



## Schools for Boys and Girls — Continued



**PAGE**  
**MILITARY ACADEMY**  
*A Big School for Little Boys*

Page takes young boys (young as six) and starts them on to strong, intelligent manhood. A school of boy sympathy and boy inspiration. Lady teachers up to fifth grade. The little fellows have the affectionate care and attention of exceptional House Mothers. Thoroughness in fundamentals insisted upon. Military training gives orderliness and manly bearing. No high school course. Send for the new Page catalog.

**ROBERT A. GIBBS, Headmaster**  
Route 7, Box 947  
**LOS ANGELES CALIFORNIA**

NEW JERSEY, Orange.  
**MISS BEARD'S SCHOOL FOR GIRLS**  
A country school, 13 miles from New York. College preparatory, special courses. Music, Art, Domestic Science. Supervised physical work in gymnasium and field. Catalog on request.  
**LUCIE C. BEARD, Headmistress.**

RHODE ISLAND, Providence.  
**THE MARY C. WHEELER SCHOOL**  
*A Town and Country School for Girls*  
College preparatory and General Course. Advanced Studio classes. Music. Secretarial Course. Farm Home for girls 10 to 14 years.

CONNECTICUT, New Canaan.  
**STAMFORD MILITARY ACADEMY**  
Thorough scholastic and military training fostering the intellectual, physical and moral needs of developing boys. Personal instruction. Small classes. Manly sports encouraged. Extensive equipment. Ideally located in the Connecticut hills. Summer Camp.  
**WALTER D. CERKEN, A.M., Principal, New Canaan, Conn.**

NEW HAMPSHIRE, Concord.  
**ST. MARY'S SCHOOL**  
A homelike school for girls. College preparatory and general courses.  
**Miss M. E. LADD, B.L., Headmistress.**

MASSACHUSETTS, South Byfield, Mass.  
**DUMMER ACADEMY**  
A preparatory school for a limited number of selected boys. Ideal country location. Moderate fees. International reputation. 160th Year opens September 19.

MARYLAND, Catonsville.  
**THE ROBERTS-BEACH SCHOOL**  
Limited number of girls, individual instruction. Strong college preparatory and general course. Outdoor life on ten-acre estate near Baltimore. Rooms with private bath. Box 900, Catonsville, Md.

**KEEWATIN for Boys**  
School with **WINTER HOME** in **FLORIDA**. Department of Commerce spends six weeks in **CUBA** and **CENTRAL AMERICA** with Caribbean Cruise. Fall and spring terms. Deerfield, Ill. Endowed, Individual instruction. Honor system. Address Secretary, Chicago Office, 1102 Masonic Temple.

In the preceding section are listed many of the leading boys' and girls' schools of the country. For further information regarding these or others, address  
**THE SCHOOL SERVICE BUREAU**  
St. Nicholas Magazine 353 4th Ave., N. Y. C.



## Joseph B. Ames

*has written a*  
crackingly eventful, exciting, colorful  
readable

*Novel of Ranch Life in Our Southwest*

## SHOE-BAR STRATTON

**I**T HAS a plot that wins interest right from the start and then never lets it wander for one moment until the always satisfactory and in this case artistically inevitable "happy ever after" of the last pages. It has healthy, warm-pulsing adventurousness; the struggles of strong men; the plucky, courageous tenderness of a fine woman. It has the thrill, the vigor and the "punch" that belongs to all outdoors. It was written for its readers to enjoy, and you will enjoy it.

**Price, \$1.75**

**THE CENTURY CO.**

353 Fourth Avenue, New York City

# SUMMER CAMPS

NEW HAMPSHIRE, Portsmouth.  
**CAMP BEAU RIVAGE**  
*(French Camp for Girls)*  
 All sports by land and sea. Address Secretary  
 57 East 74th St., New York City.

NEW YORK, Catskill Mountains.  
**KYLE CAMP** for boys, 6 to 16. Catskill Mts. Model bungalows—no damp tents. Fine bathing. Your boy's health and diversion well looked after. Movies. Modern equipments. Physician; nurse; scoutmasters; "The paradise for boys." Address Dr. PAUL KYLE, Kyle School for Boys, Irvington-on-Hudson, Box 506.

CONNECTICUT, Bantam Lake.  
**CAMP WONPOSET**  
 A camp for young boys in the Berkshires. 100 Miles from New York City. Everything a boy can wish for. Write for camp book. ROBERT TINDALE, 31 East 71st St., New York City.

LONG ISLAND, Bellport.  
**CAMP GRANGE**  
 Under the direction of experienced Directress and Counselors. Limited to fifty girls, 5-16 years. Fifty acres. All sports; ocean and still water bathing. For catalogue, address MISS C. B. HAGEDORN, 606 West 137th Street, New York City.

## Seashore Cottage Camp

Ocean City, New Jersey

Young boys. \$25 per week. Cottage modern, with electric lights and bath, right on beach. Ocean bathing, fishing, sailing, crabbing.

FLORENCE AYERS, Prin., Washington School  
 New Brunswick, N. J. July 3—Sept. 4.



**CAMP LACOTA** FOR GIRLS  
**RANGELEY, MAINE.** 9 TO 18

Lake frontage 11-4 miles. Beautiful 100-acre property. Main building is of modern construction, with full sanitary equipment. Every camp activity, athletic and water sports. Nature Study, French, Dramatics, Arts and Crafts. Limited number of girls, 9 to 18 years. References required. For booklet address MRS. M. W. ZELLNER  
 Room 1101, Times Building New York City



### For Girls (under 20 years), Roxbury, Vermont

A 300 acre wonderland in the heart of the Green Mountains. Athletic fields, private swimming pond, clay tennis courts, screened dining porch, sleeping bungalows, and a big assembly hall for plays, dances, music, and games around a big cheery fireplace. Famous for its fine saddle horses, free horseback riding, instruction, and wonderful camping trips. Separate camps for Juniors and Seniors. Enthusiastic counselors carefully chosen. Write now for illustrated booklet.

Mr. & Mrs. C. A. Roys, 10 Bowdoin St., Cambridge, Mass.

## SCHOOL INFORMATION

FREE catalogs and advice of experts on ALL Boys' or Girls' private schools (also camps) in U. S. Relative standing from personal inspection. Bureau maintained by the schools. No fees. Want for Girls or Boys? Call, phone or write.

**AMERICAN SCHOOLS ASSOCIATION**

Times Bldg., Times Sq., N. Y.; also Masonic Temple, Chicago



## CAMP DUNCAN Green Mountains Peru, Vt.

Distinctly different. High-class, individual-attention camp for twenty-five boys, 8 to 17. Enrollment accepted any part of eight weeks. Write L. E. MESAM, 20 East 60th Street, New York City.

## CAMP CONTOOCCOOK

East Jaffrey, N. H.

Featuring golf, a new attraction for Summer Camps, also bowling, athletics, mountain climbing, hikes, and water sports.

For booklet, address

FRANK W. MOSES, Carnegie Institute of Technology, Pittsburgh, Pa.  
 LESLIE WOOD, Manual Training H. S. or  
 383 St. John's Place, Brooklyn, N. Y.



"The Blue Circle" Will Fascinate You

# THE BLUE CIRCLE

By ELIZABETH JORDAN

Author of "The Girl in the Mirror," etc.

**T**HIS is one of the most original and breathlessly exciting love and mystery stories we have published in recent years. And it is beautifully told.

For very special and entirely adequate reasons, young Renshaw sells himself for a year and enters a house of mystery in the country. It is a huge house of luxurious ease, but teasingly fascinating unexplained things begin happening just as soon as he is admitted into his employer's family circle there. What happens there is the story and—and—well, we must not tell any more. "The Blue Circle" we heartily recommend. *Illustrated. Price \$1.90*



# THE TRUTH ABOUT VIGNOLLES

By ALBERT KINROSS

**H**ERE are six stories, all written around the same central character but in different settings, in England, Mesopotamia, in Cairo and other parts of the Near East. All the stories are of a feel and flavor, of a richness and variety quite extraordinary. It is fiction that captures the imagination of the reader, that gives his intelligence something to work on, that stimulates his emotion and enlarges his horizon. Mr. Kinross reveals a keen, sophisticated, humorous adult personality it is good to come in contact with.

*Illustrated. Price \$1.90*

## MORE JATAKA TALES

By ELLEN C. BABBITT

More of those delightful folk tales from the land of "Kim" and "The Jungle Book." 33 silhouette illustrations.

*Price \$1.25*

## SHOE-BAR STRATTON

By JOSEPH B. AMES

**A**STORY of love and adventure set in the Western cow country, which is nowadays adding to its perennial lure the prospect of sudden dazzling fortune through oil wells. Mr. Ames transports his readers to the great open spaces with their far horizons and plunges them into the thrilling battle a plucky girl is waging for what she believes is her property.

*Illustrated. Price \$1.75*

At All Bookstores  
Published by

**THE CENTURY CO.**

353 Fourth Avenue  
New York City

# “I’m Coming!”

It was a boy who said it as he let the flood force his shanty-boat through the jam to save the two lads on the wreckage; but it was a man in supremely tested courage and firm nerve who came out of the tremendous experiences told in



## DRIFTWOOD

By R. S. Spears

THE BEST STORY OF THE MISSISSIPPI SINCE  
“Huckleberry Finn”

A story for boys and girls of the Mississippi in flood. Full of thrilling adventure and plucky, resourceful, level-headed work of rescue. There is in it something that makes grown-up readers, too, appreciate and praise the book. It is a vivid picture of the river life and river-folk. And behind all the tense, exciting action is a movement that lifts it far above the average, that makes it at the same time an adventure story of the finest and an epic of mighty waters in irresistible flood. A remarkable juvenile; a notable American book; a book to own.

*Illustrated. Price \$2.00*

I  
WANT

.....copies of

### DRIFTWOOD

**THE CENTURY CO.**

353 Fourth Avenue  
NEW YORK CITY

for which I enclose \$.....

Name.....

Address.....



# Outdoor Books for Boys and Girls

## BOY HUNTERS OF DEMERARA

By GEORGE INNESS HARTLEY

ONE of the best combined natural history and adventure stories which has been published for years. The wonders of a region strange to most of us—the jungle of British Guiana, with its strikingly unfamiliar and interesting wild life and its Indians scarcely touched by the white man's civilization, are described through the medium of a stirring story about a young naturalist sent to collect specimens for a museum, and his still younger assistants.

*Illustrated. Price \$1.75*

## TORRANCE FROM TEXAS

By JOSEPH B. AMES

Author of "Curly of the Circle Bar," etc.

MR. AMES knows how to give boys exactly the sort of story they like best. He tells here of a Texas boy who, accustomed to the freedoms, manly tasks, rough courage and physical expertness of outdoor life, arrives at a New England school with every intention of dominating it. He discovers values he has never suspected and finds himself not a leader but often a good deal at a loss, at first,



in the strange surroundings. The story of how he found himself at last in the new environment will interest every boy, as will the lively adventures which are a part of his experiences.

After the school has gone into camp at Loon Lake, there is the added thrill of mystery on every page—for there is a "haunted house" with a tantalizing mystery which requires the attention of the boys—and receives it to startlingly good purpose.

*Illustrated. Price \$1.75*

## TINY TOILERS AND THEIR WORKS

By GRAVES GLENWOOD CLARK

ATTRACTIVE, brightly told and fascinating stories of some of the more spectacular and little-known activities of insects—the Texan agricultural ant who raises a crop; the young tarantula who never gets hungry; the strange spinning of the psyche moth, etc. The information is accurate and the treatment makes it as exciting as a fairy tale. New kinds of heroes, heroines, clowns and villains appear in an insect world whose laws and customs are as interesting as they are captivatingly strange.

*Illustrated. Price \$1.75*

At All Bookstores  
Published by

**THE CENTURY CO.**

353 Fourth Avenue  
New York City

## *The Philosopher-Vagabond Sees South America*

---



# WORKING NORTH FROM PATAGONIA

By **HARRY A. FRANCK**

*Author of "A Vagabond Journey Around the World," etc.*

**T**HE enormous continent of South America is traversed by Mr. Franck from its extreme south to its northeast corner — from Argentina to Venezuela. He sees the Rio de la Plata and the "turbid Amazon"; the pampas and the "Paris of the South," Buenos Aires; ancient Chile; the upstanding, progressive little republic of Uruguay; Rio, great Brazil, the Guianas and Venezuela.

This is an important and a fascinating addition to Mr. Franck's remarkable group of travel books. They are always welcomed, always popular, but the growing appreciation of the importance to us of understanding South America makes this one even more than usually timely and acceptable. Together with his "Vagabonding Down the Andes," it constitutes a complete picture of South America, physical, social, economic and political. The book has 650 pages and 176 illustrations from photographs taken on the journey by the author himself.

*Price \$5.00*

*By the Same Author*

## VAGABONDING DOWN THE ANDES

**T**HE companion volume to Mr. Franck's "Working North From Patagonia." In this book he tells of his adventures in the land of the Incas as he worked his way along and over the snow-clad Andes. He covers Colombia, Ecuador, Peru, Bolivia, etc.

*Profusely illustrated from photographs. Price \$5.00*

## ROAMING THROUGH THE WEST INDIES

**O**NE of the most delightful books Mr. Franck has written. He makes the reader know Cuba, Porto Rico, the Virgin Islands, Barbados, Santo Domingo, Haiti, Dominica, Jamaica, and many another memorable island asleep in the Caribbean.

*Charmingly and richly illustrated from photographs. Price \$5.00*

---

At All Bookstores  
Published by

**THE CENTURY CO.**

353 Fourth Avenue  
New York City



## *The First Book Ever Done On the Laurentians*

**T**HIS mysterious wonderland of the North, only thirty-six hours from New York City, is as foreign as France and as wild as in the days of Jacques Cartier and offers interests of infinite variety.



# THE LAURENTIANS

*By T. M. LONGSTRETH*

**A** DELIGHTFUL combination of travel, adventure and guide-book. It taps a new and inexhaustible land either for the tourist who would merely voyage in comfort up the Saguenay, for the canoeist on the lookout for new routes, for the well-read who have romance in their veins and cannot afford a trip to Normandy, or for the man who does not care to read and yet wants information on new hunting lands. It is preëminently for the person who, whether he is to visit foreign lands or not, likes to read about them and about the author's adventures in them.

Mr. Longstreth spent some time with the Chapdelaine family which appears in Louis Hemon's famous novel, "Maria Chapdelaine."

*Illustrated. Price \$3.50*

*Also By Mr. Longstreth*

## THE CATSKILLS

**F**OLLOWING his popular method, the author has produced another of his delightful and useful combinations of travel and guide books on that mountain playground nearest New York City, the Catskills. This is the region that John Burroughs loved so loyally and whose praises he sang for so many years. It is the land of Rip Van Winkle, the recreation ground for innumerable vacationists.

*Illustrated. Price \$3.50*

## THE ADIRONDACKS

**T**AKING with him a congenial companion, Mr. Longstreth wandered over the great Adirondack country; and his book is a charming record in the mood of Stevenson of the adventures of two travelers in that vast natural park. Incidentally, he gives all manner of information about roads, hotels, clubs, etc. In this, as in all his books, the author brings to the reader the very feel of the great out-of-doors.

*Illustrated. Price \$3.50*

At All Bookstores  
Published by

**THE CENTURY CO.**

353 Fourth Avenue  
New York City

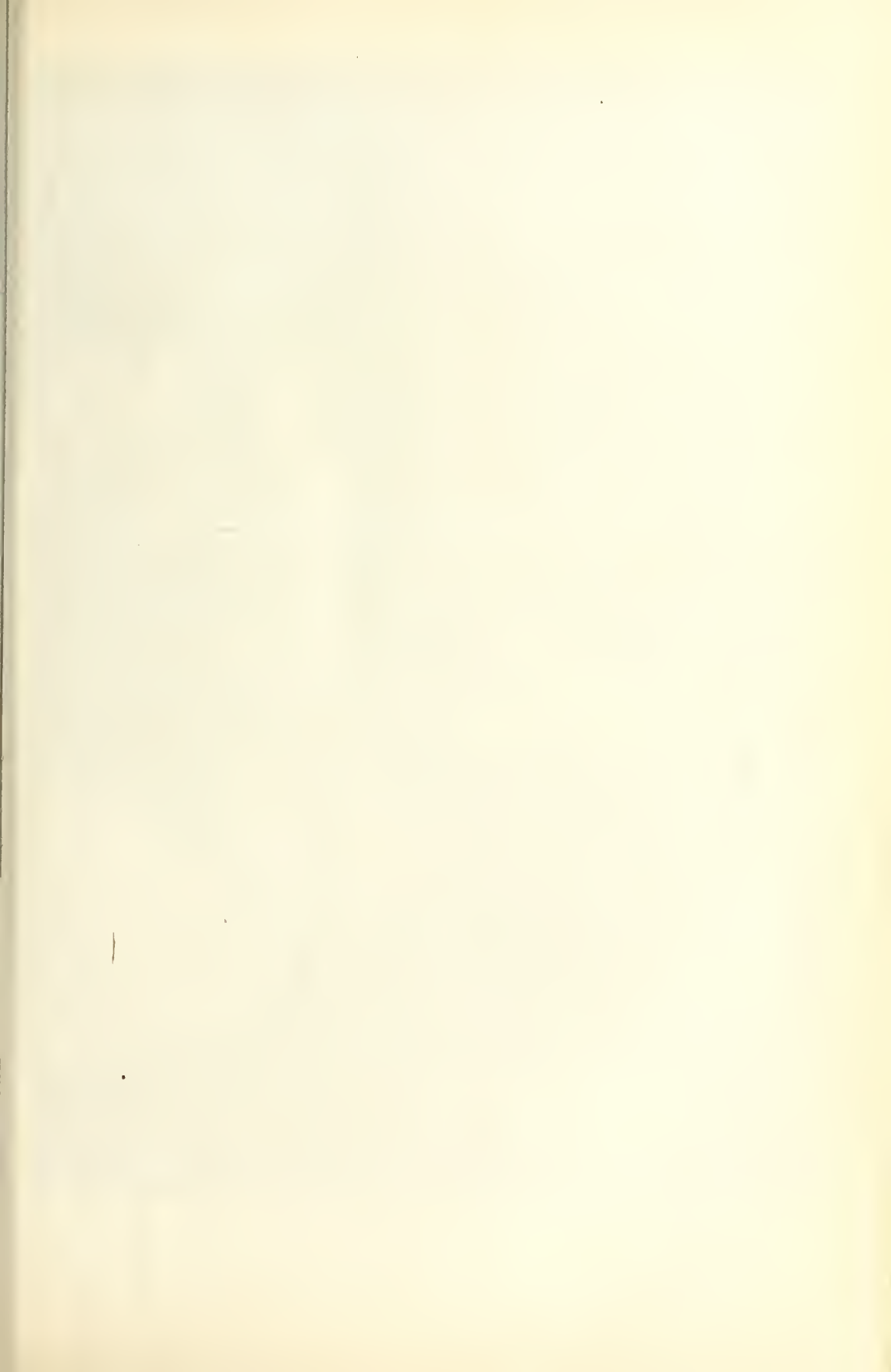



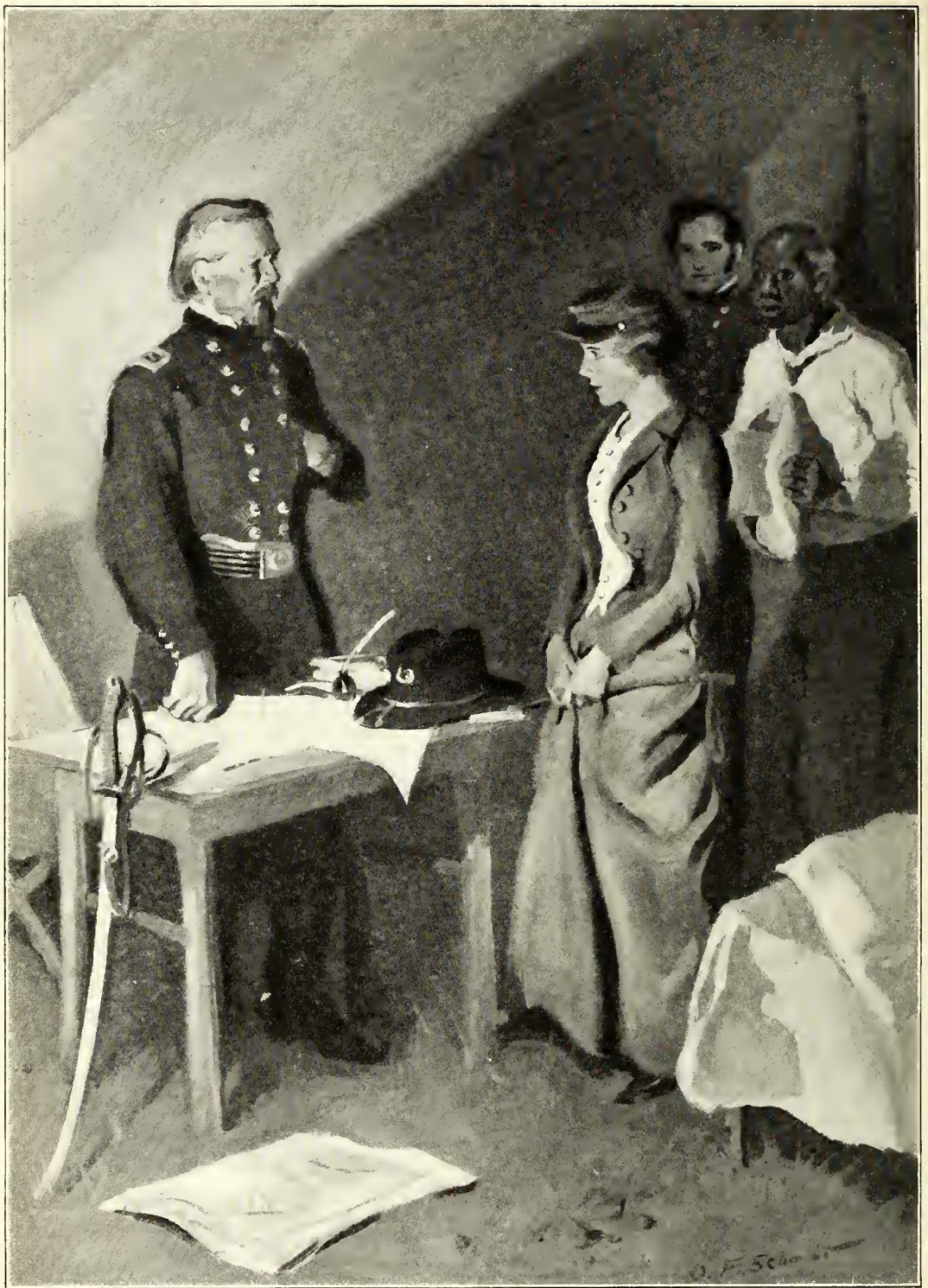

"I SEE YOU 'RE A LITTLE REBEL," HE SAID" (SEE PAGE 925)

# ST. NICHOLAS

VOL. XLIX

JULY, 1922

No. 9

Copyright, 1922, by THE CENTURY Co. All rights reserved.

## HOW THE AMERICAN ARMY WAS SAVED BY A DINNER AND A SONG

By ELLEN D. WANGNER

THE American colonists had been fighting their great war for independence for fifteen long, weary months, when the glad news spread over the land that the Declaration of Independence had been signed at Philadelphia. At last the discouraged army could fight for freedom backed up by Congress and a united country!

When, five days later, the news reached New York City by special courier, Washington was at his headquarters on Bowling Green. It was the best news that he had heard for many a long, sad day. Everything had seemed to go against him, and, at that very time, the British generals, Howe and Clinton, had a powerful fleet of vessels in the harbor, they were at the head of a well-trained army of thirty thousand men encamped around New York City, and only the day before, General Howe had landed eight thousand men on Staten Island. General Washington saw that he probably intended to capture the heights on Long Island, opposite.

Now, the heights of Brooklyn overlooked New York City, where Washington's army was encamped, and it was absolutely necessary that the Americans should hold them. If the British captured them, they could destroy New York. So Washington sent

several thousand of his best men over to Brooklyn to hold the forts there.

Washington was really dividing his army—a very dangerous thing to do, for the East River, lying between New York City and Brooklyn, was deep enough to permit British war-ships to sail into it and separate the two parts of the American army. But there was nothing else to be done—the heights must be kept, if possible.

It was on the discouraging day when this manœuvre was carried out that the messenger brought the glad news that the Declaration of Independence had been signed. Tears ran down Washington's cheeks as he read it.

"Send word that the men are to be in readiness to parade at six this evening!" he ordered simply. "We will read this wondrous proclamation so loudly that even the British will hear and understand it!"

The soldiers at once made themselves ready for the parade, and messengers were despatched to Albany and Boston with the good news.

As the courier for the latter city started up Broadway on his way to the Boston Post Road, a man on a lean black horse raced up beside him. "Can you drop this letter at the home of Mistress Murray?" he asked



hurriedly. "I would have them know these good tidings and come to witness the reading to-night." Then, as the courier took the letter, Captain Ball hastened back to headquarters, where he was on duty.

The messenger galloped rapidly along the road until he came to a big stone farm-house, built midway between New York City and Harlem Heights. It was the home of Robert Murray, a loyal and true American.

At one of its large front windows, a little girl of fourteen sat sewing at her patchwork. Outside, the hot July sun shone on the well-kept garden, with its beautiful flower beds and wide, carefully tended walks. The little girl was Katharine Ball. When the war broke out, her father had been appointed to Washington's staff. With her mother dead and no relatives near with whom he could leave her, her father had asked himself, again and again, what he should do with her. Where could he leave her, since he must be now here, now there, as the fortunes of war should determine! It had, therefore, seemed to him almost too good to be true when Mrs. Murray had asked to have Katharine come to her.

"Since I can not go to war myself," Mrs. Murray had said bravely, "let me help one who *can* go!"

And so Katharine was taken to the lovely home, where she was given a large sunny room for her very own, and where each day she practised daily on the spinet that had been placed there especially for her.

"What a surprise 't will be for dear Father when I see him again!" she had gleefully cried; only to finish sadly, "that is, if ever I do see him again!"

"To be sure you will see him again, and that right soon," Mrs. Murray had said briskly. "Only think! When General Washington shall have sent these invaders running home, he will come to New York and bring your father with him!"

But that had been many long months ago, and the British army, instead of slinking home, was growing larger and bolder each day, while the poor little American army was growing smaller and thinner and more ragged and hungry.

And so, as Katharine looked out of the window this hot July day, big tears slowly gathered in her brown eyes and fell, all unheeded, on her patchwork. Washington had now come to New York—but where was her father? If he were alive and well, why did he not come to see her? More tears fell,

and then, to her quick ears came the *thud—thud* of a galloping horse. Perhaps her father was coming now! Oh, joy! a rider was stopping at the gate! With patchwork, thread, and needles flying in different directions, she jumped to her feet and ran down to the road. It was not her father, but the next best thing—a letter from him, and she hurried so rapidly into the house that she scarce took time to curtsy to the messenger, or to thank him.

Into the wide hall she went flying. "Oh, Mistress Murray, a letter has come from dear Father. Oh—where are you?" she cried, as no sound met her ears for a moment. Dashing down the hall, she threw open the heavy door at the end, and there, in the summer-house on the rear lawn, sat Mrs. Murray, all unaware that the excited little girl had been calling her.

With a dash, Katharine cleared the low steps and flew to the summer-house.

"Read it quickly, I pray you! 'T is from my dear father! Right well do I know his writing!"

The stately woman looked up displeased. "Calm yourself!" she said severely. "I like not such boisterous manners! Sit down beside me here and adjust your ruffled appearance whilst I read the letter."

Poor little Katharine sat with wistful impatience as Mrs. Murray began to read very slowly; and then a roguish gleam crept into the girlish eyes, for Mistress Murray became as excited as she herself had been.

"The Declaration of Independence has been signed!" the lady cried. "Go bid Moses ring the bell to call the men from the fields, that all may know this! See—your father says there will be a parade this very day of all our troops, and General Washington is to read the blessed news aloud. Send Chloe to me at once—we must start immediately if we are to be in time!"

Katharine's face dimpled with delight as she saw the usually stately woman fairly run to the house, where the servants were beginning to gather. Such haste as there was! Katharine was wild with happy excitement. As she saw the horses being harnessed to the big yellow coach and knew that she was actually to drive to the city, where she had never been, tears of excitement and happiness sprang to her eyes. She was to see her dear, dear father and the general, and, mayhap, hear a band play and see the troops! Oh—was ever a little girl so happy!

With trembling fingers, she put on her best



John Wetton Adams

"RIDING UP BROADWAY, CAME THE GREATEST MAN OF HIS TIME—GEORGE WASHINGTON!"

muslin dress and tied back her brown curls with the cherry-colored ribbons that her father always liked to have her wear. It seemed but a moment until the large basket filled with luncheon was stowed away under the seat and she was sitting inside the ponderous old coach with Mrs. Murray.

Away they rattled. And now other coaches were coming into view from all the side roads, for the news had spread like wild-fire and the whole country-side was pouring toward the Bowling Green. Dust rose in thick yellow clouds from beneath the horses' feet, and the hot July sun made it very close and uncomfortable inside the coach, but Katharine did not mind such trifles. She loved the broad road with the

big trees along its sides, and she caught glimpses of stately homes and blooming gardens. Coaches, wagons, and horsemen were hurrying toward the city, and everybody seemed so cheerful and gay that she was too happy to notice such things as dust and heat.

And then they reached the city! Such crowds, Katharine had never seen in all her life! She had not thought there were so many people in the world! It was not safe to keep the horses in so dense a throng, so Moses drove them to the tavern, while Mrs. Murray and Katharine squeezed their way to the "Common," the place now occupied by the city hall, where all the troops were gathered. Almost as they reached the edge



of the crowd around the Common, came the beating of drums; and then, riding up Broadway, came the greatest man of his time—George Washington! With him, was his staff, and for an instant little Katharine forgot where she was.

"Father! Father!" she called.

The shrill little voice rose above the drum-beats and the cheering, and Captain Ball, as he heard it, saw the little figure frantically waving and gave her a military salute. He was alive—he was well—he had seen her!

Quite contented, Katharine turned to see what else was going on. The band played, the soldiers presented arms, the guns fired a salute, and General Washington sat proudly on his horse, while one of his staff read the Declaration of Independence so loud and clear that every one in all that vast crowd heard every word. Oh, how they cheered! And then the crowd turned to follow Washington as he rode back to headquarters.

Carried away by the excitement, Mrs. Murray hurried Katharine away to the tavern, and, climbing into the coach, they followed the crowd. Down to the Bowling Green surged the frantically cheering people. Katharine was so excited that it was difficult for her to sit demurely on the damask-covered coach-seat, and she kept poking her head out of the window. And once, as she did so, a curious sight met her eyes, for the crowd, spying the huge equestrian statue of King George in the center of the green, got ropes and ladders, and, with cries of "Down with it!" pulled it over.

The statue was of gilded lead, and the people cried, "We will turn it into bullets to shoot at the old king's army!" And that is exactly what was done; for, in the battle so soon to come, these bullets were fired with a will.

In the cool of the evening, the Murray coach went slowly home again, with Katharine, worn out with the excitement, asleep on one of its wide seats. It had been a wonderful day for her and for all the little city; the happiest, alas! that it was to know for a long, long time. For the British general knew that Washington's army was divided, and he knew just what would happen to the American army if he could once capture Brooklyn Heights. He also believed that if he could compel Washington and his troops to retreat, nothing could save the American army!

So day by day the seven thousand American soldiers fortified the heights and got

ready for the battle they knew was coming, while Washington watched and waited and did everything that he could to prevent the disaster that he feared.

Slowly the days dragged by; and then, at the end of August, the British general struck—in front, sides, and rear, all at once. Before noon, the battle was over and nearly half of the American troops had been killed, wounded, or taken prisoner, the remainder fleeing within the fortifications. General Washington was in one of the forts, and tears rolled down his face as he saw how powerless he was to help his men. Had Howe stormed those fortifications at once, it might, indeed, have been the end of the war. But Howe knew how our men had fought at Bunker Hill, and he had no desire to storm any heights held by such soldiers!

The wind and rain of that dreadful day helped the Americans, for Howe could not bring his big war-ships up the East River against the wind. But Washington knew what would happen when the wind shifted; he knew his danger and that he must withdraw his men from Long Island while there was time. Giving quick, secret orders that every craft that could possibly be used was to be brought to the Brooklyn ferry that night, he anxiously watched lest the wind, that was still holding back the English fleet, should change. The boats soon gathered, and all that night the soldiers rowed the troops over the wide river. But when day came, only half of the army was across. But again the weather helped, for such a thick yellow fog settled over the water that the British could see nothing of what was going on. Wounded men, cannon, stores, horses—all were safely ferried across; and when, at the end of the day, the wind shifted and Howe's ships sailed up the river, the soldiers who marched into the fortifications did not find so much as a rusty horseshoe left behind!

Washington had been the last man to leave. Tired and sad, he attended to every detail of this retreat, considered one of the greatest in history. Many of his officers had been killed, many more were wounded. Captain Ball had been hurt so seriously that it was believed he could not live. Very carefully, he was carried up Broadway to the Murray house, there to see once more his little Katharine.

It was a very anxious group that helped to place the wounded captain in the big four-post bed in the sunny guest-room. To Katharine, it seemed as if her whole little

world had been turned upside down. Would her dear brave father never smile at her again? Was there nothing that a little girl could do? There was much, indeed, that she could busy herself with, as brave Mrs. Murray soon showed her. Lint must be picked for wounds, errands must be run, hot water must be brought from the kitchens, so

filled with the fleeing troops, until all but four thousand men, under General Putnam, had left the city. These soldiers had remained to guard the ferries and, if possible, to keep the British from landing until the main part of the troops had safely entrenched themselves at Harlem. But when General Howe attacked New York, these four thousand



"AND BRAVELY DID LITTLE KATHARINE SING, WHILE THE AMERICAN ARMY SLIPPED PAST" (SEE PAGE 905)

far away from the sick-room, bandages must be torn and bleached in the sun to make them "sweet." So all day long, day after day, Katharine's busy feet flew up and down, up and down the stairs for her dear father, who was still making a brave fight for life. Hope was beginning to spring up in all their hearts. Perhaps, oh, perhaps he would live!

But no word came of Mr. Murray; and Mrs. Murray's face grew sad and white when she heard that Washington was at last being driven out of New York City! Oh, it could not be true! Surely, reinforcements would be sent to the Americans! But it *was* true, and soon cannon, horses, men, and supply-wagons began to file past the big house on their way to Harlem Heights. All the roads running up the island were

men could not stop him, and they, together with Washington himself, were nearly captured. But they managed to evade the British, and hot, tired, and discouraged, began to flee along the roads toward Harlem. Every moment they expected to be attacked in the rear, and if they were beaten, nothing could save the American army at Harlem Heights.

Past the Murray house, straggled the weary, fleeing army, and Katharine, looking from the windows of her father's room, saw her beloved General Washington go by, his head sunk on his chest.

"The end has come, then!" Mrs. Murray cried brokenly. "What can we do, with the British holding New York? Our house will be seized, your father captured, and we, also,



like as not!" Then a sudden thought came to her. "Katharine, call Chloe and Moses at once! Your father must not remain here! The British will soon be following our weary troops—oh, what *shall* we do!"

But when Chloe and Moses came at the frantic call, it was found that Captain Ball could not possibly be moved. What was to be done? Nothing, but for Mrs. Murray to lock the door of his room and put the key in her pocket.

With pale face, little Katharine climbed up to a high window-seat that commanded a view of the road for a long distance. All the morning she watched, and then, hearing a bustle on the floor below, she slipped quietly down to see what was the matter.

"Where have you been, child?" demanded Mrs. Murray, quickly. "Hasten! We shall need every hand! I have a plan—poor, it may be, but much better than none at all. I have heard that these British officers would stop the war for the sake of a good dinner, and 't is my plan to serve them such a one as will halt them until our men are safely in Harlem. Help me, so that we may have everything in readiness!"

All went quickly to work. Chickens, ducks, and geese were prepared and soon sizzling in the huge ovens; crocks of butter and honey and pans of thick cream were brought from the spring-house; and Chloe and all the other maids busied themselves making fruit tarts and pies.

Then Katharine was again sent to keep watch. As she caught sight of the first red-coated officers trotting up the road, her brave little heart sank within her. A foolish plan it seemed—no doubt, they would refuse to stop except to search the house and find her father! And then they would go on and capture General Washington! She sped downstairs to Mrs. Murray.

"They are coming!" she cried; "some men on horses and the soldiers on foot! There must be thousands of them! Surely, if they stop, it will be only to capture poor Father!"

"Courage!" whispered Mrs. Murray, while her own lips trembled. "Be brave for your father's sake!" Then she walked out on the lawn as calmly, to all appearance, as though it were an every-day occurrence to receive British generals.

To the perspiring officers, the mansion looked a most delightful place, with its green lawn and graveled walks and rustic seats. And how gracious its mistress looked as she sent her servant down to the gate! What

was their surprise when they found they were asked to stop for dinner! Oh, this was too good to be true! A midday repast in this big, cool house could not be refused.

"Let the ragged Americans go as far as they can run!" cried General Howe, gaily. "I 'll warrant we 'll chase them all the faster for a good meal." And dismounting, he and all his staff entered the grounds.

"Nay, not your staff alone, but the other officers!" said Mrs. Murray, graciously. "My servants will gladly prepare enough for all!"

The private soldiers were ordered to stack their arms and wait their superiors' pleasure. Calmly Mrs. Murray watched to see that every officer was on the lawn,—that not one should be left to think of pursuing the Americans,—and then she devoted herself to the task of entertaining her guests. She was a talented, charming woman, and it was so pleasant to rest in the patches of shade on the green lawn on such a hot day that the officers were only too glad to forget the fleeing enemy. Mrs. Murray had given orders that, once the British were on the lawn, the preparations for dinner should be delayed as much as possible; every moment counted.

The meal could not be held back too long, however, and when it was ready Mrs. Murray led the way into the great dining-room. General Howe and General Clinton exchanged glances that seemed to say, "This was worth waiting for!"

"Oh, if only they would not eat so rapidly!" thought Mrs. Murray, anxiously. "If only I might think of some other means to delay them!"

But the meal was finished at last and the officers rose.

Now all this time, little Katharine had been peeping through the big doors as Chloe and the rest had served the dinner, and she saw the look of anxiety that, for just an instant, flitted across Mrs. Murray's face. Her love and fear for her father helped her to understand it. Those men must be delayed somehow! If—oh, if she dared! *She* could keep them at least a little longer. Should she dare—she was half-way in the room—*she would!*

Walking gravely over to Mrs. Murray and curtsying low to the officers, she asked sweetly, "And would you like me to sing for you, perhaps?"

Mrs. Murray's hand closed tightly on the little shoulder near her—would these men

stay for such a mere trifle as a song from a child?

General Howe was, indeed, in haste to be gone, but, looking at the grave little maid before him, he bowed low as he answered, "'T will be a pleasure, little lady."

Now to Katharine Ball had been given a good voice; but so sad and anxious had she been since coming to the Murray house, that not once had it been heard, and Mrs. Murray listened with surprise to the clear, sweet voice as the little girl sang "Sally In Our Alley," the new song of that day. Genuine applause greeted her, and then she sang some quaint negro songs that she had learned from Chloe and Moses.

"By Heaven, 't is a treat!" cried General Clinton. "More! More!"

And bravely did little Katharine sing, while the American army of four thousand men slipped past not half a mile away. The last straggler was safely in Harlem by the time that Katharine sang the last song that she knew, and the officers, bowing low over her hand as well as that of Mrs. Murray, said good-by.

And the next day, in the Battle of Harlem Heights, the American army made the enemy pay heavily for their success on Long Island, for in that engagement the little army that had been saved by a dinner and a song wiped out the memory of a bitter defeat.



## THE PINCH-QUITTER

By WILLIAM T. TILDEN, 2D

World's Tennis Champion 1920-21

EDWARD MORRIS, ex-national tennis champion of the United States, turned away from the court in disgust. It was a bitter blow to the former star to admit, even to himself, that his son, the boy he had raised and on whom he had staked all his hopes, failed in the one thing for which his father had been noted.

It was the final round of the lawn-tennis championship of the United States. His only son, Edward Morris, Jr., and Billy Jolson, the wonderful little star from the Golden Gate State, were fighting the final match with the title at stake. At least,

Jolson was fighting. In the opinion of the father, Ted was lying down on the match. It was an old story to Morris Senior. For the past three years Ted had come through to the final round of the biggest tournaments, beating the greatest players in the country on the way, only inexplicably to fall down in the big test at the end. For some time, the father had been fighting the fear that it was lack of nerve that caused this demoralization on his son's part whenever the stake was high. It was indeed a bitter blow, for, above all else, the father prided himself on his own courage under a severe test.



Now his son was throwing away the American championship because he had not in his system the fight to withstand the attack of Jolson. The boy's game had crumpled in the first set, when Jolson broke through his service, and never again had Ted shown the slightest sign of offensive attack. In his father's eyes, it was a disgrace. Mr. Morris left the grounds before the players had come from the court. He could not trust himself to see Ted just then, for he had made up his mind to thrash the matter out with the boy once for all. He would have no quitter with the name of Morris playing tennis if he could avoid it, least of all a son of his.

Ted Morris was twenty. Reared in an athletic atmosphere, gifted with a body of unusual strength, a quick, keen brain, and a love of sport, he was a born champion. There seemed no reason for his inability to come through and win safely in the pinch.

Ted offered no "alibis" for his defeat. He dressed quickly, only pausing again to congratulate Jolson as the latter passed him on the way from the showers. Ted had seen his father leave the grounds during the last set.

"I guess the old Dad is a bit disgusted with me," he muttered to himself. "In the old days, he never knew what it was like to lose."

Just as he was leaving the club-house, the president of the National Tennis Association met him in the hall. "Hard luck to-day, Morris! You did n't seem to have your usual confidence. By the way, the Davis Cup Committee met to-day just before the match to pick the team for this year. It was a big chance to take, waiting until two weeks before the team sails for Australia, but we wanted to see the results of the national championships before making our decision. Of course, you and Billy Jolson were certainties, once you reached the finals, so the outcome of the match made no difference in our selection. The other

men will be Dick Thomas, as captain, and young Richard Vincey. All the other men have already told me they would go. I spoke to your father just before the match, and he said he was willing for you to play and might even go with you."

"That 's wonderful, sir! I am delighted. If Dad said I could go, why, you can count



"'QUITTERS ARE NOT DAVIS CUP MATERIAL'"

me in, for there 's nothing I would rather do."

Ted arrived home to find his father awaiting him in the hall.

"Come to my den, Ted," he said; "I want to talk to you."

"Just a minute, Dad; I 'll be right there."

The boy threw off his coat and hurried to the little room which served his father for office, smoking- and sitting-room.

"Dad," he burst out, as he crossed the threshold, "I 've made the Davis Cup team for the Australian trip, and I hear that you said I could go and that you 'd go with me!"

"Sit down, Ted," his father spoke coldly; "I have something to say to you about that and other tennis matters. I have changed my mind about that trip since the match this afternoon. Quitters are not Davis Cup material."

"Quitters!" the boy caught his breath sharply; "I don't understand."

"Then I 'll explain more fully. I have watched you a long time and far more closely than even you realized. I have fought to hide the truth from myself, but to-day I was forced to admit it—you—my

son, the boy that I have raised and coached myself, are a quitter. Where you get it from, Heaven only knows, I don't; but when the big test comes, you fail. No. Don't interrupt. Wait until I am through. Then you can say anything you want. You have reached the finals in fourteen tournaments during the last three years, out of which you have won two. The others you lost just as you lost to-day, because you lacked the sand to fight. You quit cold at the moment when you should produce the best that is in you. Do you think that I am going to allow you to go to Australia as a member of the American Davis Cup team, when I know in my heart that in the pinch, when the big test comes, you will fail? Never! It might cost the cup."

The boy sat silent for a moment, his face white and drawn. "You really think that of me? You, the dad I have looked up to and admired, whose judgment I trusted above all else? Why, Dad, you have missed the whole point. What is the incentive to win in these tournaments? It is the one of mere personal gain. I play tennis because I love the game and enjoy the competition. Once I have reached the finals, that incentive for striving is gone—nothing is left but the spoils of mug-hunting. Somehow, it kills my desire to win. Don't get an idea that I don't *try* to win; I do. But the old keenness is gone. If I had a stimulus of some sort in the finals, something that made me feel it was worth while, I could often win. The incentive to play for America *is* such a stimulus. I would play the best tennis of my life. And now you are going to take it away from me! It is n't fair. Give me a chance to prove what I have said."

Mr. Morris looked up. He was impressed by Ted's manner as much as by his words. For the moment, he questioned his own judgment. Had he misunderstood the boy? He sincerely hoped so.

"That is all very pretty; but suppose that incentive fails and you are responsible for losing the cup. I am not willing to have my name dragged down in the tennis world at this late date."

"Give me my chance, Dad. It 's all I ask—just a chance to prove to you that I am not what you seem to think I am. Come along yourself and see!"

"Don't worry! I 'll be there if you go."

"You 'll come, Dad. Please—it 's my big chance!"

The former star looked his son squarely in

the eyes. "I 'm no quitter," he said; "yes, I 'll come."

The two weeks that followed passed in a rush of preparations for the trip that made serious tennis impossible. Almost before Ted realized that he was going, he found himself on board the *S. S. Niagara*, bound "down under." In the party were Billy Jolson, Richard Vincey, Dick Thomas, the captain, and the two Morrises. The three weeks on the ship were a welcome rest to the boys, all of whom were "over-tennis'd" from the hard season just completed.

The Davis Cup matches were staged this year at Melbourne, where the public interest ran very high. The demand for seats far surpassed the capacity of the grounds. The American team was quartered comfortably at Menzes Hotel, the traditional home of all Davis Cup teams in Australia. It was from there that the "Big Three," Beals Wright, William A. Larned, and Maurice E. McLoughlin, went down to glorious, but unexpected, defeat to Norman Brookes, Alf Dunlop, and Rodney Heath. From Menzes, J. C. Parke won world fame by defeating Brookes and bringing home the Davis Cup to England. The cup had had many a voyage since then, for it had passed to America and then to Australia, only to return to its native land after the World War. Now it was again in the land of the kangaroo, so once again Menzes Hotel quartered a challenging Davis Cup team.

Ted Morris was a hard-worked boy during the first days of practice in Melbourne, for he was the player on whom the rest of the team tuned up. Dick Thomas, the captain, was uncertain in his own mind as to the relative merits of Vincey and Morris in singles, so every day found the two boys fighting out for position. Thomas himself and Jolson were the natural selection for the doubles, and the only practice they could obtain was at the hands of their team-mates.

The matches were but a week away when Thomas called a meeting of the squad to discuss the selection of the players. He had full authority to make his own decision, but, like all wise captains, he preferred to have the advice and opinion of all who were vitally affected by his choice. He invited Mr. Morris, Senior, to the meeting, but the older man declined on the ground that his own son was one of the men under discussion and it would be rather out of order. Vainly Dick tried to persuade him to change his mind, but the other was set in his opinion.



The meeting was held in the sitting-room of the boys' suite of rooms at Menzes. Dick called the meeting to order in his usual off-hand, informal manner.

"Fellows," he said, "I have asked you to meet here for the selection of our team. To-morrow we start the final work of tuning up strokes and perfecting training. No more competition among ourselves for position and no more hard tennis. The question of the team must be settled to-night, as you can see. Before I make my choice, I wanted to hear your views. Naturally, Billy Jolson, as national champion, will play the singles; and since he and I have won all the matches with you, Ted, and Vincey, I imagine that you will agree with my selection of Jolson and me as the doubles team. If that is so, it comes down to the question of Vincey or Morris as the second singles player."

Billy Jolson looked up from the paper he had been reading. "Dick," he said, "it seems to me that the selection must rest on three things: results of matches down here between the two men, the records of the past season in America, and, finally, which one has the nerve in the pinch."

Dick drew a paper toward him from a bundle that rested on the table. "You are right, Billy. Since the two boys have come down here, Morris has won seven out of twelve matches. During the season at home, Ted beat Vincey three times in early rounds of tournaments, but lost two final rounds to him decisively. As to nerve in the pinch, personally I am willing to count on them both."

The two boys under discussion sat red and embarrassed while their fate was settled.

Billy took the sheet of paper from Dick's hands and carefully studied it. "It looks like Morris, by a shade, to me," he announced at last.

"That is my opinion," Dick agreed; "I pick Morris. Congratulations, Ted. Hard luck, Vincey."

The little towheaded lad grinned. "You're quite right, Dick; Ted is the man to pick."

Suddenly, Ted found himself on his feet; something he could not stop had him in its clutch, and he was talking rapidly.

"Dick, just a minute before you make your final choice," he heard himself saying. "You must know one thing: my father—" his voice caught suddenly,—"my father says I'm a—quitter. He says that is why I

always fail in the final rounds. I thought you ought to know."

Dick looked him squarely in the eyes. "Is he right?" he asked quietly.

Ted met the look with one just as steady. "No," he said, "no. At least, I don't think so!"

Dick rose from the table. "Neither do I," he remarked, turning away. "Jolson and Morris in the singles for America."

For some minutes Ted sat with head bowed. He did not realize that Billy and Dick had gone. Then a hand dropped on his shoulder and he looked up to find Richard Vincey standing at his side.

"Go to it, Ted! I'm glad you made the team!" The ring of real pleasure sounded clear in the boy's voice. "Go in and win. Quitter! You a quitter? Gee, your Dad is barking up the wrong tree!"

"Thanks, Vincey, I'll try not to throw you all down. Well, I suppose we must turn in."

MR. MORRIS gazed sternly at his son from the depths of the great arm-chair in which he was seated.

"Dick tells me you are to play the singles. You have your chance now. Do you think you can make good, or will you fall down in the pinch again?"

The boy looked his father straight in the eye. "I will make good," he said quietly.

"Has Dick followed your record closely this year? Does he realize that you have failed in every important final-round match you have played? It is America that counts at this time, not your personal desires or even the chance to prove you can make good. It is the cup for America, and nothing may stand in the way."

"You are right, Dad. It is for America, and nothing must stand in the way. If I felt that I were endangering the team's chances, I would not step on the court; but I am sure that I'll play the best tennis of my life. If I lose, it will not be through poor play on my part, but better tennis by my opponent."

"I wonder if I should tell Dick what I fear." Mr. Morris rose from the chair.

"There is no need to do that."

"Why? Has he the same ideas, or is it that you do not wish to run the risk of losing your position on the team?"

"No, Dad, it is neither. It is simply that I told Dick what you thought of me."

The man turned sharply away from his





"TED CAME TO LIFE WITH A SNAP" (SEE PAGE 912)



son. "You told him? Why did you do that?"

The boy laid his hand on the other's shoulder. "Why, if I were a quitter, I had no place on that team. It is for America, as you said, and Dick was entitled to know if any one, even my own father, considered that I might fail in the pinch. I guess, since it was my father, it was even more important that he should know. Anyway, I told him. I hope you don't mind."

Mr. Morris turned, a light in his eyes that Ted had not seen there in many a long day, a light of understanding and trust. "Mind, Ted, mind? I'm proud of you. I have misjudged you and regret it deeply. You are no quitter."

THE great crowd of tennis fans stormed the stands of the tennis-club, overflowing them until they stood around the court itself. It was the first day of play in the Davis Cup matches, with Jolson paired against George Palmerson, in the first match, and Ted Morris drawn with John Henderson, the rising young Australian flash, to close the day's schedule.

The American team was not at its best; in fact, Captain Dick Thomas was a worried man. Billy Jolson had eaten something the night before that seemed destined to upset the ordained scheme of things, for he had spent a wakeful night that had robbed him of much of his customary vigor. He seemed so ill that Dick Thomas seriously considered playing Vincey in his place; but morning found Jolson up and more like himself, so that Thomas finally decided to count on Billy's nerve and great experience carrying him through, rather than trust to Vincey's untested skill.

It was a magnificent battle against great odds that Jolson waged. For two hours he fought Palmerson to a standstill, meeting speed and dashing attack with finesse and brain-work of the highest order. The end of the fourth set found the men tied at two sets each, but Jolson on the verge of collapse from sheer physical exhaustion. Gamedly the wonderful little Californian rallied his strength, but the toll had been too great. Palmerson held a reserve that even Jolson's nerve could not overcome, and America went down with colors flying when Palmerson drove a terrific service ace by the wearied Jolson. It was a bitter blow to America, for the match should have been hers under ordinary conditions. Henderson, the second-string Australian, was a player

of ups and downs. On his day he might beat any one. Decidedly it was up to Ted.

The boy took the court nervous and over-anxious. Unfortunately for him, it was very much Henderson's day. The Antipodean was at his best in all departments, and, valiantly as Ted struggled and bitterly as he fought, the best he could do was to pull out the third set.

Two points for Australia, and but three matches more to play. One more American defeat, and the cup was lost for the year. Jolson was so ill the next morning that Thomas selected Vincey for his doubles partner, in the forlorn hope of saving the match and rounding Jolson into condition for the final day of singles. It proved a wise move, for the youngster played as if inspired, and, aided by the ever-ready advice of Dick Thomas, swept the opposition away and brought home the match for America in four sets.

The day's rest proved its value to Jolson, who appeared at the club on the final day full of his customary "pep." Ted accompanied his team-mate, leaving his father to follow.

"I shall be a little late," Mr. Morris had said. "I'll motor out as soon as I complete some other business."

Jolson's match with Henderson was a masterpiece. He swamped the Australian in three sequence sets by a display of tennis that had never been equaled on the historic court at Melbourne. Ted went to the locker-rooms to dress at the close of the second set. The end was in sight and inevitable, so he decided to dress leisurely before the close of the match. It was up to him. The score was two matches all, and the cup hung on the result of his meeting with Palmerson. His chance had come to prove to his father once for all that in the real test he could produce his best. It was for America. He must make good.

He was just pulling on his sweater, preparatory to going out to see the end of Jolson's match, when Dick Thomas came hastily into the room. "Hello, Dick"; he said, "it's more or less up to me, with the emphasis on the more."

"Ted," Dick spoke quietly, "it may not be up to you, after all. I'm sorry to tell you that I have had a telephone message that your father has been seriously injured in an automobile accident. He is in the Melbourne Hospital and has sent for you. You had better go at once."

"Dad! hurt? But, Dick, it—it is n't serious—it can't be!"

"I'm sorry, Ted, old man, but I'm afraid it is. They said for you to come at once."

"Because the rules provide that no substitution may be made after the first match, except in the case of illness of one of the players. It requires a doctor's certificate."

Suddenly the voice of the referee ran out from the grounds: "Linesmen out for the Palmerson - Morris match."

Ted picked up his rackets. "I'm ready, Dick," he said quietly.

Dick grasped his arm. "You'd better go to your father."

"No, I am going to play the match."

"Ted, you *must* go. He may be dying."

The boy turned white and sat down suddenly on the bench. "I thought so," he said. "Dick," he turned to his friend, "it is Dad or America, can't you see? Dad said that *nothing* must stand in the way of America, and nothing shall. I am going to play that match."

Silently Dick grasped his hand, and the two passed out of the locker-rooms to the court.

Ted was dazed. He could not rouse himself to his surroundings. The cheering thousands that thronged the stands made no impression on him. He hardly realized that the match was under way. The first thing that brought him back to himself was the voice

of the umpire calling, "Game and First Set, Palmerson 6-3."

Ted fully roused himself at that. He had dropped the first set, but what did that matter? He must pull out the match. Palmerson was playing well. He showed unusual control of his shots, which told Ted that he had one of the most terrific battles of his career before him if he hoped to win. Hoped to win? He *must* win!



"NO, I AM GOING TO PLAY THE MATCH"

"But the match, Dick! What about the cup? Can you put Vincey in my place?"

"That does n't matter now, Ted. Don't think about that. You just chase along. I hope you'll find things better than you fear."

"Dick," Ted insisted, "can you put Vincey in? Tell me. I must know."

"Well—no, Ted, I'm afraid I can't."

"Why not?"



The second set found Ted playing his game for the first time. His strokes gained in speed and aggressiveness, as he concentrated every faculty on the match. Game after game the two players fought each other to a standstill. It was magnificent tennis, worthy of the cup that was at stake, representing, as it does, the crown of international athletic achievement. Finally, Palmerson weakened for a moment in the furious net attack which he had adopted. The pace was telling on him. Ted seized his opening, and, with an offensive of his own, crashed through for the set at 8-6.

Ted had forgotten his father in the heat of battle; but in the moment of breathing-space afforded between sets, memory rushed back. He wondered if his father still lived—would he reach him in time? Almost before he realized it, he had again relapsed into the mental haze that had cost him the first set. Dick Thomas on the side-line saw the change and shuddered. It would mean the cup if Ted did not rouse himself. There seemed nothing but a miracle between him and defeat, for Ted dropped the third set at 6-2 and was trailing 4-1 in the fourth. The end was in sight. The boy did not realize that defeat was staring him in the face; he hardly knew he was still playing.

Then in his memory a voice spoke—clearly, sharply, through the mist of mental suffering. His father's tones cut into his consciousness, "It is the cup for America—nothing must stand in the way!"

Ted came to life with a snap. Had his father really spoken in his ear? No, his father lay in the hospital—hurt, possibly dying. What was it he had said? "It is the cup for America—nothing must stand in the way." Very well. Nothing would.

Life, strong, vigorous, and powerful, rushed through Ted's body. His mind cleared, and he again grasped the full significance of his position. It was almost too late—almost, but not quite. Sternly he set himself to the long fight back. It was a frightful hole into which he had allowed himself to fall. Nothing but perfect courage and daring would avail at this crisis, but Ted had those qualities at his command. Step by step, game by game, he pulled up to even terms.

Finally, he broke the terrific service of Palmerson and ran out the fourth set at 9-7.

The crisis was passed. The tide had turned for the last time. Ted swept to victory on the crest of his brilliant rally. The match was his, 6-4, in the final set. The challengers had been successful and the cup returned to its native land, America.

Dick met Ted as he came from the court. "Great work, boy! Congratulations on the rally. They just telephoned from the hospital—"

"Dad—" the boy broke in huskily.

"He is better and is asking for you."

"Come with me," cried Ted, rushing off in his tennis clothes to the waiting automobile, dragging Dick with him.

The door of Mr. Morris's room opened softly.

"Dad! oh, Dad!" and Ted threw himself on his knees beside the bed.

"Why, boy, I'm all right. Don't worry. A few cuts and a nasty scalp-wound—that's all. Why did n't you come when I sent for you?"

"Dad, the match was two-all when I heard about your accident. They could n't substitute Vincey, you know. You said to me once that it was the cup for America, and nothing must stand in the way. Well, this was you or America, and—America won!"

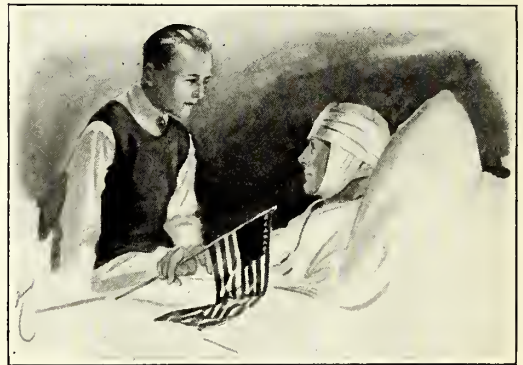

"NO, DAD, YOU—AND AMERICA—WON!"

"You played, Ted! You played under that strain? How did you come out?"

The boy raised his head, "You said it was the cup for America, and nothing must stand in the way. I heard you say it to me on the court to-day when Palmerson had me licked at two sets and 4-1."

The man turned slowly to his son. "You won?"

"No, Dad, you—and America—won!"

# THE POT O' MAGIC

By GRACE JEWETT AUSTIN

STATIRA turned the key of her father's lock-box in the little country post-office and drew out one thin letter directed in a shaky hand to

MISS STATIRA BROOKS,  
LYFORD,  
N. H.

She looked at the printed return, "Farwell and Company, Fort Hill, Montana"; and the shaky hand had also written, "1006 Custer St."

"Why, that must be from Great-aunt Statira, the one I was named after! It's been a long time since we heard from her."

The little post-office and grocery was stuffy in the warm July afternoon, so Statira crossed the bridge over the lazy Pemigewasset River, sulking because there was no rain to make it sing and dash. An old elm stood by the river-bank, and a slab of granite beneath it made a seat. Here in the shade Statira read her letter.

Fort Hill, Montana.

Dear Statira:

When the pretty card about your school graduation came, I meant to buy you a little present, but I could not get downtown. Now I have decided to send you my "magic kettle," and maybe you can earn some money with it. Before I was so stiff, I used to like to earn a little for gifts and church money. Put a gallon of soft water in the kettle and heat it to boiling. Add four teaspoonfuls of cooking-soda and four of salt. Stir with the long tin spoon I send, and put silverware into the kettle. You will be surprised to see how you can clean even black pieces.

Write to your old aunty one of these days, and remember me to your parents.

Your great-aunt,

STATIRA.

Statira read it over twice, and then sat watching the little ripples in the river. A robin hopped along and looked up so intelligently that she asked him a question:

"What if I could earn enough money for my art course? Why, everybody will have some silver to clean! Oh, I wish the kettle would come this very day!" But that was n't at all likely.

When half-way home, another idea struck Statira and almost sent her into a run in spite of the hot day.

"Where's Father? Where's Father?" she called excitedly at the door of the kitchen, where her mother was making currant jelly.

"Father? I think he is mowing in the six-acre lot. Would n't you like to carry him a cool drink?"

Statira nodded and fanned herself with her hat. "If it's buttermilk, I'd like some too."

"No, it's ginger-molasses water. That is better for both of you when you are heated."

Statira made up a little face at the old-fashioned drink, but owned to herself it tasted good after all. So before long, Farmer Brooks saw a pretty sight as his girl in pink gingham came stepping over the stubble with her big brown pitcher. They sat down in the shade, and the farmer let the breeze blow his thin hair.

"Hot enough to put cabbage-leaves in our hats, eh, sis?"

But Statira's mind was too busy to notice heat. "What do you think, Father! I've had a letter from Great-aunt Statira, and she's going to send me a magic kettle to clean silver. I was wondering if I could n't take Uncle Joe's old 'shop' and make a cunning place out of it, and earn money—lots—and maybe go to Boston to study art!"

Farmer Brooks looked dazed. "Magic?—Shop?—Say it slower, daughter."

So Statira patiently told her plan with more detail. Near the road below the orchard stood the empty little shop where her mother's old uncle once did a small cobbling business, left empty to the spiders since his death. Statira saw it painted, saw a sign, "Here is the Pot o' Magic," and saw its interior changed to a studio. Farmer Brooks always found it hard to deny his girl anything he could manage to give her, so he nodded and said with a chuckle:

"You'll find most folks use their own elbow-grease on their silver, sis, but go ahead. I'll whitewash the old shop out and in, if that will help any."

Statira flung her arms around his neck. "I hoped you would! Oh, I hoped so! But I hated to say so when you're so busy. I'm going to begin this very afternoon." And she went flying across the fields.

Next, the pink-gingham dress went back into the closet and a sober dark-blue percale came out. A small mountain of brooms, mops, cloths, brushes, soap, scouring-powder, and hot-water pails gave her loads for several



trips to the musty little shop, closed for years. Her mother thought with a smile that if she had made Statira put on that morning-dress and work so hard all that long hot afternoon, she would have had a very aggrieved daughter. As it was, she could hear down the lane a happy voice singing:

"Merry the day and merry the play,  
For the pot o' Magic to make a way;  
Silver will shine and silver will gleam,  
And joy will flow in a happy stream."

The whole Brooks family took an interest in the Pot o' Magic shop. Father was true to his word, and the little building was white as a snowball. Brother Joe put up an iron arm for a sign, and nailed together the boards on which Statira painted in artistic letters, "Ye Pot o' Magic—Come In." Mother gave a rag floor-rug, and as much old attic furniture as Statira chose. The garden furnished posies for decoration, and a little oil-stove was ready to put the magic kettle boiling. These preparations filled the days till a big battered parcel-post package brought a large aluminum kettle and a long tin spoon. Near the door a neat card read:

#### PRICE SCALE

Large pieces . . . . . 10 cents  
Small silver . . . . . 50 cents per dozen

Now all that was lacking was customers.

"I'll do your silver free, Mother," Statira offered.

"No, indeed!" her mother laughed; "I feel honored to be the first customer. Hunt out every piece in the house, and I'll stick to the 'price scale.'"

More to keep busy than to make her mother's bill grow, Statira hunted the house over for every bit of silverware it contained. On a shelf in the shop, she established her great triumph, a tilting ice-pitcher that had been discarded for years in black humility. Now, in radiant glory, it was useful both for advertisement and refreshment for thirsty customers.

But where were the customers? Poor Statira felt like Alexander with no more worlds to conquer. She was sitting on the door-step with a melancholy chin in her hand one morning when Joe came along in the small car.

"Hullo, sis. In the dumps? It pays to advertise. Make some stickers, and I'll put one on the wind-shield and stick 'em up in the post-office and places. Miss Kate would put one up in the library, maybe."

Statira sprang up and blew him a kiss, "Smart boy! Why did n't I think of that myself?"

So two more days were busy ones, for Statira was very painstaking with her posters. "What's the good of being an art student if I can't do pretty posters?" she declared. So she made big ones and little ones till at last a dozen were done. Saving the most elaborate to take to Miss Kate, she gave the rest to Joe.

Down in the center of the village stood the library, an unpretentious little wooden building, but the first to be pointed out to a stranger, because in the years long past it was a court-house, where a young lawyer had stood to argue one of his first cases. No one listening then to Daniel Webster realized that one day he would be the greatest orator of his nation. The little building was outgrown by the law, degenerated to a blacksmith's shop, and then was rescued by patriotic women and made a town library. Here Miss Kate Barker, a forty-second cousin of the great statesman, spent her days urging Rollo books on little boys and Dickens on their elders.

The little gray-haired lady was all alone when Statira hurried in. "Miss Kate, dear, could I put up a poster in the library?"

"What is it for, a concert?"

"No-o, I suppose it is 'private gain,'—and I just remembered that's forbidden."

Miss Kate trotted over and looked at the tasteful poster and then at the girl's disappointed face. "Sit down and tell me all about it, Statira."

Statira was only too glad to go over the whole story, ending with a sigh. "But I don't think we need to worry about 'private gain.' Father said everybody used their own elbow-grease on their silver, and I guess he was right."

Miss Kate nodded briskly. "That being the case, dear, let us put it up as an art object. If any one finds fault, and 'private gain' has begun to come in, we'll take it down."

While Statira was putting up her poster with thumb-tacks, Miss Kate sat watching her with a thoughtful look on her face.

"Statira," she said suddenly, "I can't afford to be a customer, but I'm going to contribute something to the Pot o' Magic. Before poor Tom Lunt left for France, he disposed of the old Lunt place. He was the last of the family, and his mother had had to mortgage the farm. By selling everything, the poor fellow came out clear and that was





"MISS KATE, DEAR, COULD I PUT UP A POSTER IN THE LIBRARY?"



all. The night before he left he rapped at my door and came tugging in a heavy bushel basket. 'Miss Kate,' he said, 'I guess it's worn out trash I'm bringing you, but I sort of hated to throw it out. It's old, black, plated silver that, for twenty years, Mother

Statira gave her a wild hug. "I can hardly wait for to-morrow! Oh, Miss Kate, you'll come over and see it, won't you? How I do hope it comes out bright!"

All the morning, Statira was a busy Martha in blue percale, and the magic ket-



"THE MAN'S EYES WERE ON THE SILVER, AND HE GAVE AN AMAZED WHISTLE"

was too feeble to rub up. But she always kept the closet locked where it was put, so she must have valued it a little.' Statira, I just choked up. It did n't seem any more than yesterday since he was bringing pennies to the primary class. I knew I had no use for that old black stuff, but I took it as pleased as if they were diamonds. And now, poor laddie!—asleep in France."

The little library was very still for a minute, then Miss Kate said brightly: "So you send Joe over to-night with the car, and you can have a busy day to-morrow. I'll warrant your mother has an old what-not up in the attic, and if the silver comes out bright, it will show off finely,—and no need to worry to carry it back and forth, as you have to do with your mother's silver."

tle steamed like a witch caldron. The silver came out so wonderful, so beautiful, that Statira kept gasping with admiration—the lovely lines, the beautiful simplicity of some of it! Statira began to wonder if Miss Kate ought to give it away so freely. She thought excitedly, "I'll have a party!" So the faithful Joe was sent to the library with a note:

Dear Miss Kate:

Do come over to the Pot o' Magic when you close the library at five. We'll have afternoon tea together, and I can hardly wait to show you the silver.

With love,

STATIRA.

Then the little shop was beautified to the limit. Big jars were filled with field and garden flowers; a little table was spread for

tea, and at one side of the room the towering what-not fairly gleamed with silver pieces. Statira, in her fresh pink gingham, a rose in her hair, was sitting waiting impatiently, when a car stopped before the door and a woman's voice said:

"See this darling tea-shop! Let 's go in."

Statira had time for just one blush before a fine-looking pair of visitors crossed the threshold. The man's eyes were on the silver, and he gave an amazed whistle.

"Why, pardon me, but— Sue, this is almost past belief!"

"What is, Jack?" Then the speaker noticed Statira back in the corner. "Oh, may we have tea in this lovely place? I did n't suppose there was such a unique tea-room in New Hampshire."

Statira had almost lost her tongue, but now she came forward, "I 'm sorry, but it is n't really a tea-shop. It 's a silver-polishing shop. But I 'll be glad to give you some tea, because I was expecting a friend—the one who owns this old silver—" and she waved her hand casually at the what-not.

"'Owns this old silver!' " murmured the man.

"But we must n't spoil your party—though it looks so very good, and we are as hungry as hay-makers."

Statira was now as eager to have them stay as at first she had been reluctant, "Oh, do stay! Miss Kate eats like a little bird, and I 've lots more cakes, and bread for sandwiches."

While the hungry people ate they asked questions, till they learned the whole story, even about the desired art lessons in Boston.

The man smiled a very kindly and amused smile. "What would you say if I should tell you those silver pieces, if they were yours, would give you many courses in art?"

Statira fairly turned pale. "Many—courses? In Boston? Why, how could that be? Miss Kate did n't suppose these were

valuable at all. She said I could leave them here nights."

Then it was the man's turn to gasp. "Sue, it was probably Providence that made us turn into this road. Miss Brooks, do you know that most of those pieces are solid silver? And what is more, that is the finest collection of Paul Revere silver I ever saw in my life. You said the soldier boy's name was Lunt. I remember reading that Revere had friends of that name. I 'll warrant that silver an heirloom for a hundred and fifty years."

Then Statira stood up very straight.

"Oh, sir, please forget what I said about the art lessons. This all belongs to Miss Kate. She is n't very well, and she earns barely enough to live on. It will be such a wonderful thing for her!"

"DID you call me, Statira?"

"Oh, here she is!" cried Statira, as joyously as *Little Bear* finding *Goldilocks*.

It was really an exciting moment to the pair from Boston, also. To see the little limping, gray-haired lady slowly realize that a very considerable sum of money had come for her straight out of the Pot o' Magic was a pleasant thing to watch. But there was Bunker Hill in her backbone, also. She sat as straight as Statira.

"Not a penny will I touch, Statira, unless it is divided equally! Without you, it would have stayed in the basket till my death. I can't make it seem real yet, what the gentleman says—but *Paul Revere!*" She took up a cream-pitcher with an air of reverence.

Just then Statira had an inspiration worthy of the hospitable Paul himself; "Let 's use it! Let 's use it on this lovely occasion! It 's all shining clean, and whoever buys it won't grudge us this one tea-party."

It was the work of only a few moments to put many of the silver pieces into action, and then the smiling good genius from Boston lifted his cup with a toast:

"Here 's to the Pot o' Magic, the Artist, the Librarian, and *Revere!*"

---

## FORTUNE

FORTUNE is a cheery lass,  
Easy to beguile.

If you weep, she 's apt to pass—  
So—why don't you smile?

Mary Carolyn Davies.





Photograph by U. S. Forest Service

"RANGER BILL"—SILENT DOER OF DEEDS"

## THE GUARDIAN OF UNCLE SAM'S FORESTS

By WALLACE HUTCHINSON

HAVE you ever met him,—guardian of Uncle Sam's great National Forests; silent doer of deeds,—the forest ranger? Perhaps you have seen him out West on the lonely mountain trail or beside a glowing camp-fire; but if you have not "eaten bacon" with him, and reached a point of friendship where you could call him "Ranger Bill," you have not learned to know him for his true worth.

The forest ranger typifies the land in which he lives, for he is a true Westerner, no matter where he was born. The bigness of the out-of-doors is in his heart, and his manners bespeak the quiet places of the hills. As pioneer and guardian, he stands on his worth alone "out among the big things."

Fearless of man or beast, he roams amid the solitude of giant forests and snow-capped mountains. Danger is his constant bed-fellow, but he sleeps quietly. His day's work is filled with more hazards than is a year in the life of an ordinary man. When duty calls, be it night or day, he answers the summons. He is an idealist, and it is this idealism that makes his hardships a matter of enjoyment.

The work of a forest ranger is not highly remunerative; in fact, it is one of the poorest paid of all government jobs. If he longs for high position and big salary, he quits

and seeks other fields. But most often, the call of the great outdoors, the freedom of mountain and plain, is so deeply instilled in him that he stays on, hoping for better things, yet willing, if need be, to make many sacrifices in order that the work that he has well started may not be left to unskilled hands.

The ranger is an officer of the law, a fire-fighter, woodsman, surveyor, game-warden, and oftentimes the leading man in his little community. His back yard covers ten thousand acres, and his universe stretches onward and upward, past valley and forest and peak, to the clear air and sparkling sunshine of the heavens.

To meet Ranger Bill, and listen to his tales of adventure, is like reading a wonderful book of romance. His understanding of men and animals and birds and trees is the heritage of the wilderness, unsullied by envy and suspicion. In him you will find a modest hero, not such, perhaps, as we know from books, but a quiet, gentlemanly fellow living happily through a life of ideals—a real man!

One of his interesting and strange adventures is told in the story begun on the next page—"A Strand of White Horsehair"—the authenticity of which I can vouch for from personal knowledge.

# A STRAND OF WHITE HORSEHAIR

*How Ranger Bill Celebrated the Fourth*

"I 'VE pulled a lot of strange jobs for Uncle Sam since I took over this Rabbit Ears District," remarked Ranger Bill, carefully blotting the finish of his day's diary, "but this 'arson squad' game is the most exciting I ever worked at. Did n't know I was an amateur fire-detective, did you? Well, I ain't exactly, my early training having been along quite some different lines, but what 's a fellow going to do when people try to burn up the forest the Government pays him to protect? Go out and catch them, I guess, and that 's just what I 've been doing.

"You see, we have between 5000 and 6000 fires every year in the National Forests, and about 80 per cent. of them are what we call 'man-caused,' that is, set by campers, motorists, brush-burners, railroads, sawmills, and the like. Then, too, there 's quite a bunch of incendiary fires, set by folks who don't have any love for the Forest Service, or the woods either—spite work, most of it.

"We 've got a mighty fine fire-fighting organization, but the only way to make fire protection effective is to cut down the number of man-caused fires by rounding-up the people who set them, either through carelessness or on purpose, and letting them feel the hand of the law. But I 'm telling you it 's a heap easier to locate the *origin* of a fire than it is to discover its *originator*. Saying that a fire started up on Squirrel Creek from a cigarette don't get you anywhere in particular unless you can lay your hands on the fellow who carelessly threw it away.

"The most surprising thing to me about all this detective business is the way one will pick up a little clue that often leads to the discovery of the guilty party. I reckon I never told you how I rid this district of one of the toughest characters that ever rustled a living out here in the Rockies? 'T ain't a long story.

"Two years ago it was, on the grand and glorious Fourth of July. Everybody in the Rabbit Ears country was down to Deer Trail celebrating and having a right joyous time. I went down early with the family to make a day of it, but hardly had the team unhitched when a boy came running to say that Central had a 'phone call for me. I

hurried over to the office and found Chet Norris, of the Black Butte fire-lookout station, waiting for me on the line.

"There 's a fire over on the winter cattle-range of Fishback Brothers, near Twin Rocks,' reports Chet, 'and she 's booming up right handsome. Sorry to spoil your Fourth, but you 'd better be getting over there with a crew of men.'

"'Funny place for a fire on a day like this! All the Fishback outfit is right here in town, including the cowboys. I 'll get after it right away. Good-by!'

"As I came out of the office I ran into Forest-guard Morris coming to find out what was the trouble, so I set him to getting together a bunch of men and fire tools while I rustled a flivver. In less than an hour we were at the scene of the blaze, and by some hard work and good luck had the fire under control by noon.

"When the rest of the bunch, all except a patrolman, had gone back to town, Morris and I started out to run down the cause of the fire. It was as plain as the nose on your face that it did n't start from a cigarette carelessly dropped by some one passing along the trail, as the starting-point was fully a hundred and fifty feet from the main line of travel and in a kind of pocket where there was a heavy stand of wild oats. After a careful search, we discovered the tracks of a small barefooted horse right close to where the fire began.

"We had a great time following those horse-tracks, but by sticking with it for an hour or so, we found where the horse had been ridden up the trail from the east, off the trail and down to the place where the fire started, and then back again to the east. Most of this tracking work we did on our hands and knees, and sometimes all we had to go on was a small circle of broken grass-stems to show where the horse had stepped. Finally, the tracks led out into a dusty trail, and from there on we had little trouble in following them down to the Rickson ranch.

"Rickson and his outfit were not at the ranch, having gone down to Deer Trail for the celebration, but we found a young fellow named 'Bud' Simpson, who was known to have a police record and a cattle-stealing reputation, cleaning his saddle in the back



yard. I told him about the fire and asked him to catch up a horse and go up and act as an emergency patrolman until I could get another man from town. He fussed around considerable about getting a horse and said he would walk to the fire, but I finally persuaded him it was too far.

"The way Simpson acted kind of made me suspicious; so while he was out wrangling in the pasture, Morris and I did a bit of sleuthing around the place. First thing we noticed was Simpson's bridle hanging on the fence, with a few white horsehairs caught in the concha on the brow-band. I pocketed these, and then we went hunting for his saddle-blankets, which we found thrown over the rack in the shed. They were soaking wet and covered with white hairs, showing that they had recently been used on a white horse that was fat and soft from lack of riding.

"Being kind of 'het-up' from all this tracking work, I went over to the pump to get a drink. I was just raising the tin cup to my lips when, in the mud around the watering-trough, my eyes fell on those selfsame

tracks we had followed all the way from the fire. Close by lay a salt-sack, which had evidently been used to groom a sweaty horse. I stuck this sack into my saddle-bag as possible evidence. About this time Simpson rode in bareback from the pasture on a light-brown horse. Offhand, I noticed that this animal was shod on three feet.

"How come you did n't go down to the celebration to-day?" asked Morris.

"Was n't feelin' right good," replied Simpson, with a surly growl.

"Thought I saw you out riding a white horse this morning as we went by," I said boldly, hoping that I might catch him napping.

"No!" comes back Simpson, right quick, "I have n't been off the ranch since the boys went to town."

"You see, I did n't want to accuse him point-blank of having set the fire, because the evidence we had was pretty slim, and people out here in the West don't take kindly to being called a 'fire-bug'—specially when they are one.

"So we all went back to the fire-line and I



"MOST OF THIS TRACKING WORK WE DID ON OUR HANDS AND KNEES, AND SOMETIMES ALL WE HAD TO GO ON WAS A SMALL CIRCLE OF BROKEN GRASS-STEMS TO SHOW WHERE THE HORSE HAD STEPPED"

put Simpson on patrol and told Morris to stay by him and see if he would talk. Then I lit out to where the fire started and did a bit of private investigating.

"I did n't bother with any tracks this time, but searched through the brush for other signs. I had about given up hope, when all of a sudden I ran across a long strand of white horse-hair caught on an oak-bush. It matched up fine with the strand I had taken off of Simpson's bridle.

"Now it was up to me to find the horse to match the hairs, so back I went again to the Rickson ranch. Starting with the barefoot tracks at the watering-trough, I followed them to a bunch of trees in the pasture below the house, and there, sure enough, was an old white nag dozing away under a big pine. The saddle-marks had been all washed off his back, but, looking closer, I saw fresh cinch-marks underneath and where little streams of sweat had run down his forelegs and dried. I knew I had my man dead to rights then.

"Back to the fire I went as fast as I could ride. 'Simpson,' I said, piling off my horse in front of him, 'you 're under arrest for starting this blaze. Your old white horse left some strands of his tail-feathers on the brush back here close to where the fire started. I've got the goods on you. Come along!'

"He knew we had him, so he climbed on his horse without a word and I took him down to the justice of the peace, where he was bound over for trial. In default of bail,

he laid around in the county jail for several months, and the judge gave him an extra thirty days for good measure. It came out in the trial that he had a grudge against Rickson and had set the fire along the trail

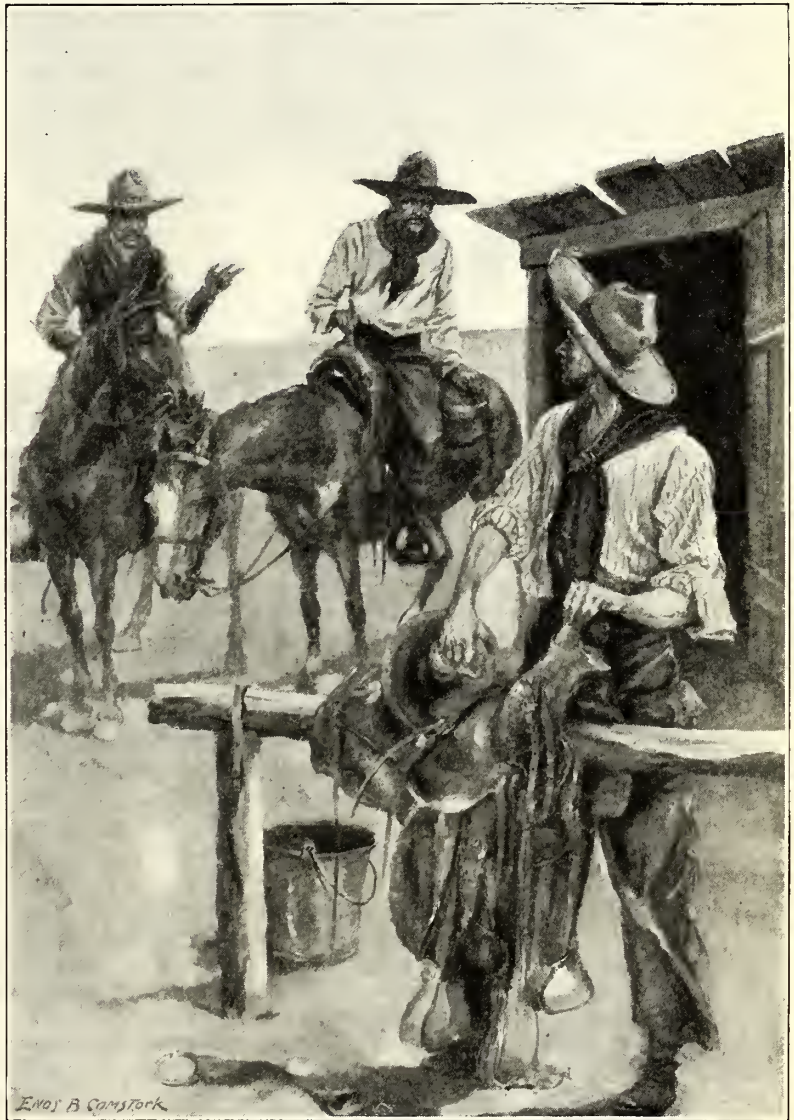

"THE WAY SIMPSON ACTED KIND OF MADE ME SUSPICIOUS"

the boss took to town, hoping it would burn up the grass on the range and get him in bad with the cattlemen.

As soon as Simpson got out of jail he sold what little property he owned and left, without further delay, for parts unknown. That 's how the Rabbit Ears District 'got shet' of one of its worst characters."



# THE COVERLID

By MARY WELLS

It lies along the back of the old mahogany davenport, the coverlid, its rich blue and dull scarlet softened into only greater beauty by passing years, for the coverlid dates back to pre-revolutionary times. The story has to do with my own grandmother, Susan Howard Warren, and I tell it as it has often been told to me.

Sue Howard was not yet fifteen in those summer days when Lee's gray-clad troops swept up the eastern side of the Blue Ridge, with Meade's men keeping dogged pace at their right.

The Howard plantation was directly in the path of the steadily advancing Union troops, and here, save for a few negro servants, Sue and Miss Cecilia, her father's oldest sister, were alone, Colonel Robert Howard being with Pemberton in beleaguered Vicksburg and Lieutenant Tom Howard with Lee himself.

Sue's mother had died when Sue was a baby, leaving her little daughter to the care of gentle Miss Cecilia. Sue had grown up loving every spot of the old plantation and the surrounding country. One of her greatest pleasures was to ride with Tom or old Uncle Ephraim through the pine woods and up the winding mountain road to the cabin of Miss Alida Grant.

Through the small garden of carefully tended flowers, a path led up to the weather-beaten little dwelling. The quaint interior had a never failing attraction for Sue. A wide fireplace lay along one side. On the floor were braided rugs. Over the mantel an old-fashioned clock ticked away the slow minutes. By the window overlooking the wide sweep of valley stood the arm-chair in which had sat Alida's father, grandfather, and his father before him. In one corner was the bed with its plump mattress of feathers; and there, spread so smoothly that not a wrinkle was visible, lay the coverlid.

What the shining old mahogany in the great Howard parlors, the yellowing lace of her grandmother's wedding-veil, her grandfather's seal ring were to Sue, that and more was the coverlid to the gaunt old mountain woman, last of her race.

Sue and Alida often talked of the coverlid. "It's wonderful, Miss Alida," said Sue, "but it must have been a lot of work."

Alida Grant nodded. Grandma made it every bit herself back in Vermont when she was only sixteen. When my great-gran'ther found out that she and Thad Simmons were aiming to get married, he gave her half a dozen sheep as an engagement present. Thad sheared them, and the carding and spinning Grandmother did herself. Many a time I've heard her tell how soft and white the long rolls were. Next came the dyeing. Indigo and madder, she used. Some folks think cochineal gives a prettier red, but nothing could have kept its color better than this.

"After the Revolution, when Thad got his government grant, they came to Virginia. Grandma carried that mirror all the way, with the coverlid wrapped around it."

"It's a beautiful pattern, Miss Alida. Has it a name?" asked Sue, admiringly.

"'Virginia Beauty,' most folks call it—chariot wheels and the double cross. There are a lot of fancier patterns, but, to my mind, this is the prettiest of them all. I've got the draft yet."

Alida went to the tall chest of drawers and took out a strip of yellowing paper which she carefully unrolled.

Sue bent over it curiously. "What funny little marks! They look just like the strokes Miss Rowley used to have us make in our copy books. I don't see how your grandmother could tell a thing about them."

"Each one of those little marks means something," said Miss Alida. "They're easy enough to figure out if you know anything about weaving. It's like picking out stitches in fancy embroidery. As for the coverlid, Grandma gave it to my mother when she was married, and, as I was the only girl, it naturally came to me. I set considerable store by it."

Miss Alida's gnarled hand rested caressingly on the beautiful folds.

After the outbreak of the war, Sue in her loneliness went more often than ever to the little cabin on the mountain-side. Not that she and Miss Alida had the same views. In all Virginia, there was no stancher little rebel than Sue, and, with the blood of New England forebears in her veins, Miss Alida was as uncompromisingly Union. Strange as it may seem, their very differences drew

them nearer together, and the young girl in her anxiety for father and brother found comfort in Miss Alida's homely counsel and rugged strength.

All through the early summer of 1863, there had been rumors of a Confederate advance, and at last rumor merged into certainty. One June morning, Negro Ben rushed excitedly into the great hall where Miss Cecilia and Sue were sitting.

"De Yanks are comin' dis time fo' shuah, Miss Cely. Mass Holland's Joe done see 'em ovah by de ford, big guns, baggage-wagons, and all. Dey 're aimin' to head off General Lee."

Miss Cecilia and Sue hurried out on the pillared porch. In the silence of the summer morning, listening, they could hear far away a dull, continuous rumble. Miss Cecilia's delicate face grew pale.

"I hope they 'll go by the lower road," she said.

Even as she spoke, at the bend beyond the woods, there arose a cloud of dust, and, galloping up the road, came a troop of blue-coated cavalry. With a jingle of spurs and a clank of sabers, they swept up the driveway to the porch. The leader, a young soldier with the bars of a first lieutenant, swung himself from his horse. At the foot of the steps he paused and took off his cap, bowing low. Sue noticed the glint of the sun on reddish-brown curls and the lines of weariness in the young face.

"Madam," he said, addressing Miss Cecilia, who stood slenderly erect, "the day is hot; my men are tired and thirsty. If you will kindly tell us where we can find water?"

Miss Cecilia turned to the gray-haired old negro at her back. "Ephraim," she said, with calm dignity, "show this—gentleman the well. Sue, come into the house."

"Dis way, sah," said the old negro, respectfully; and following his guidance, the company rode around to the rear of the mansion.

The young lieutenant lingered, his eye on Sue.

"I have a little sister just about your age up in York State," he said, a little wistfully.

Sue thought of Tom, also riding north through the summer day. In her imagination, somehow, she had never pictured Yankees as pleasant-faced young men with little sisters. Despite herself, her heart softened towards the enemy.

"Her name is Mary," went on the young man. "I have her picture here." From

his breast pocket he took a little velvet case and handed it to Sue.

Instinctively she took the daguerreotype. A merry-faced little girl with a wealth of curly hair looked up at her.

"Her hair 's red, too," said the soldier, with a smile; "runs in the family."

"Sue, my dear," came Aunt Cecilia's voice in surprised accents.

"Yes, Aunty," answered Sue; then, "Wait a minute!" she commanded the young man. She ran into the house, and shortly returned with a pitcher of water and a glass which she held out to the soldier.

"I hate Yankees," she said, head high and voice firm, "but I like Mary."

The soldier drained the glass twice, then mounted his horse. He raised his hand in military salute. "Thank you for Mary," he said. Then turning, he gave a quick command to his men, and the company rode away. At the gate he paused to wave his hand.

All day, at intervals, groups of dusty blue-coated soldiers plodded by. Sometimes companies stopped at the well-house, then resumed their weary march; caissons lumbered along drawn by mules; a group of artillery clattered past. Once Sue heard the far-off sound of cannon, and her heart contracted as she thought of Tom. Then she said, "I hope nothing will happen to Mary's brother."

At last all the troops seemed to have passed. Sue, who through the day had thought often of Alida Grant, sought Miss Cecilia, and said:

"If you don't mind, Aunty, I 'm going to take Uncle Eph and ride up to Miss Alida's."

"Oh, my dear! I 'm afraid it is n't safe, with all these Yankees around," answered Miss Cecilia, anxiously.

"The Yankees have all gone long ago, Aunty," coaxed Sue. "None of them would climb way up there, anyway. I feel as if I must see Miss Alida. Please, Aunty!"

And before the eager pleading, Miss Cecilia reluctantly consented.

An hour later, Sue and the old negro drew rein before the little garden-plot. As Sue glanced at the yard, she gave a cry, then sprang from her horse. Something was clearly wrong. The palings were broken and the flower-beds trampled. Throwing the reins to Ephraim, she ran up the path and pushed open the door.

In the usually spotless room, disorder



reigned. The rugs were disarranged and soiled with marks of muddy feet, chairs were overturned, a skillet lay broken on the hearth. In the chair by the window sat Alida Grant, her hands clasped tightly. She was staring rigidly before her.

Sue ran to her. "What is it, Miss Alida?" she cried. "Oh, what is it?"

Alida turned slowly toward the corner. Her face worked painfully. Sue followed her gaze—then broke into indignant speech: "They 've taken the coverlid!"

Slow tears rolled down Miss Alida's wrinkled cheeks. "It was a Union man that took it. That 's what hurts the most. Not but what I 'd give the coverlid and all if it would help any; but when I tried to tell him how it was, he only laughed."

"The coward!" cried Sue. Then, with sudden resolution, she threw her arms around Alida's neck. "Don't you fret, Miss Alida. I 'll get the coverlid!"

Before Alida Grant could utter a word of protest, Sue was out of the house and into the saddle. Sue rode rapidly down the mountain-side till she reached the main road; then she turned abruptly to the right.

Uncle Ephraim rode up. "Whar you gwine, Miss Sue?" he demanded. "Dis road leads to de Yankee camp."

"That 's where we 're going," said Sue.

The old negro looked at her in undisguised dismay. "'T ain't safe, Miss Sue!" he expostulated. "Whatever 'll Miss Cely say?"

"You hush, Uncle Ephraim. I 'm going to get Miss Alida's coverlid." Sue's cheeks were flushed and her eyes flashing. "If you don't want to go, I 'll go alone." And she urged on Dixie.

"Hi-yi!" came a familiar voice from behind.

Sue turned as Negro Ben came riding up.

"Miss Cely done sent me to meet you-all," he explained.

"You 're just in time," said Sue, in a relieved tone. "You tell Miss Cecilia that Uncle Ephraim and I have gone to the Yankee camp for Miss Alida's coverlid, and tell her not to worry."

Without more ado, Sue cantered on, leaving Ben staring in open-mouthed astonishment. Ephraim followed her doggedly. Through the heat and dust of the summer afternoon they rode. They passed group after group of infantry trudging in the same direction. An occasional band of cavalry

went by them. Though many glanced curiously at the two, nobody molested them.

Twilight was already deepening when, from a rise of ground, they saw before them the camp-fires of a bivouacked army. The evening breeze brought them the distant hum of voices.

Now that her goal was in view, it seemed to Sue that she could never gather courage to carry out her purpose. Her heart beat rapidly. Then there rose before her Alida Grant's face as she had last seen it, and she started down the slope.

Half-way down the hill, the horse swerved sharply.

"Halt! Who goes?" rang out a voice; and from the shadows a sentry stepped, laying his hand on Dixie's bridle. Uncle Ephraim rode quickly to Sue's side.

Sue leaned from the saddle. "I want to see the commander," she said earnestly. "It 's important."

The man looked up wonderingly at the young girl. He hesitated, then his hand dropped. "Pass," he said. "Ride straight ahead. Headquarters is in the tent with the flag. You can't miss it."

By the dim light of a lantern swung from the tent-pole, Colonel John Wainwright was dictating certain orders to Lieutenant James Warren when an orderly entered. He saluted.

"A messenger for the colonel. Important business."

"Show him in," said the colonel, briefly.

There was a curious expression on the orderly's face as he held back the tent-flap. The colonel looked up, then sprang quickly to his feet. Before him stood a young girl in a dusty riding-habit, with a Confederate cap on her dark hair. A white-haired old negro stood behind her.

"How can I serve you?" began the colonel; but the girl was gazing not at him, but at the lieutenant.

"It 's Mary's brother!" "And what are you doing here?" they cried simultaneously.

Then, recovering himself, the lieutenant turned to the colonel. "Colonel Wainwright," he said, "permit me to present to you Miss Sue —"

"My name is Susan Howard," said Sue, with dignity, "and I have come to get Miss Alida's coverlid."

"Miss Alida's coverlid!" ejaculated the colonel. He turned an inquiring gaze on the lieutenant, but Warren shook his head.

Then, briefly, Sue told her story. As he

listened, the colonel's face was grave, but when at last he spoke, there was a humorous twinkle in his eyes. He glanced significantly at the gray cap.

"I see you 're a little rebel," he said.

"Yes, I am a little rebel, sir," answered Sue, sturdily; "but won't you please help me to find Miss Alida's coverlid?"

the search began. From tent to tent, from group to group they went, but not a trace of the coverlid appeared. Nearly the entire camp had been traversed. Sue's eyes ached with looking, and a lump rose in her throat. Always before her she saw Miss Alida's face. "I must find it, oh, I must!" she whispered. She was startled by Uncle Ephraim's



"A SECOND SHOT WAS HEARD. THE SOLDIER SWAYED, THEN STRAIGHTENED HIMSELF" (SEE NEXT PAGE)

"Who ever let you come here on such an errand?" demanded the officer.

"Nobody let me come," said Sue. "Uncle Ephraim tried to stop me, but I just had to come or it would have been too late. But won't you please hurry, sir? I 'm afraid Aunt Cecilia is pretty worried."

The colonel turned to Warren. "Lieutenant Warren, I appoint you escort to the enemy. If Alida's coverlid is in this camp, find it. If any soldier has it in his possession, put him under arrest at once."

The colonel's voice was very stern. "Cowardly trick!" he said. "And see also," he added, "that Miss Sue has proper escort to her home."

He held out his hand to Sue. "Good luck, little rebel!" he said smiling.

"Thank you, sir," said Sue. Her dark eyes were grateful.

Warren having summoned an orderly,

excited voice. "What 's dat ober dar, Miss Sue, dar by de ribber?"

Sue looked in the direction indicated. A group of men were gathered about a camp-fire whose wavering light was reflected in the stream. In the background, stretched between two saplings and serving as a screen, she caught a glimpse of blue and scarlet. Forgetting everything else, she ran forward.

A thick-set, coarse-faced man was concluding some story. "And you ought to have seen the old girl's face when I grabbed the blanket!" He laughed boisterously.

All at once he found himself confronted by a dark-haired fury of a little girl in a gray Confederate cap. She gathered the coverlid in her arms, then turned to the astonished soldier. Her dark eyes were flashing.

"It was a cowardly trick!" she cried.

The soldier sprang angrily to his feet, but



he found himself looking into the gray eyes of Lieutenant James Warren, whose right hand held a cocked pistol.

"So you 're the coward who goes about robbing defenseless old women." Warren's tone was contemptuous. "It 's men like you who bring disgrace upon the army." He turned to the soldier accompanying him.

"Purvis, conduct this man to the guard-house. His case will be settled later."

With an evil glance at the group, the man slouched off under guard.

Unfastening the coverlid, Warren folded it carefully and placed it in Sue's arms.

"Take it to Miss Alida," he said. "And now I think we had better be starting. The sooner you get home, the better."

"Oh, you must n't come!" cried Sue. "You have been riding all day and you look so tired. I don't mind a bit. Uncle Ephraim will look after me, and besides, I 'm so happy!" Sue clasped the coverlid close, her eyes shining.

But when she and Uncle Ephraim rode out of the camp, Lieutenant Warren and his orderly rode with them.

"Poor Aunt Cecilia!" said Sue. "I suppose she 's awfully worried, but she won't mind when she knows." Sue patted the coverlid on the saddle-bow. "Oh me, I 'm glad, glad, glad!"

They soon branched from the main road and were riding up the mountain. Another turn, and the cabin would be in sight. They were passing through a clearing where the moonlight sifted through the branches, when suddenly from the underbrush a shot rang out. Instantly the lieutenant urged his horse between Sue and the thicket. Even as he did so, a second shot was heard. The soldier swayed, then straightened himself.

"Low in your saddles," he commanded. "Now—ride!"

Up the mountain flew the little company. Evidently the shot had been the work of some straggling soldier, some night prowler, for there was no other report.

Now the gleam from the cabin was visible. At the gate, Sue sprang from the saddle without waiting for help. Strangely enough, in the midst of danger she had felt no fear. Now her heart swelled in anticipation of Alida's joy.

She turned to speak to the others. She was just in time to see the lieutenant sink forward on his horse's neck. The orderly and Uncle Ephraim hastened to his side.

"We 'll have to get him into the cabin right away," said the soldier, anxiously.

Sue flew up the path and pushed open the door. The cabin had been restored to its usual immaculate order. Alida Grant sat gazing sadly into the dying embers. At the sound of the opening door, she rose quickly; but at the sight of Sue, the look of apprehension faded from her face. Then her eyes fell on the coverlid, and her arms opened involuntarily.

The child ran to her, thrusting the coverlid into those waiting arms. "Here 's the coverlid, dear Miss Alida; but they 've shot Mary's brother." Sue's face was white.

Already the soldier and Uncle Ephraim were bringing in the lieutenant. His eyes were closed, his face was pallid, and on the shoulder of the blue blouse a spot was widening ominously.

"Lay him down there." She pointed to the bed. "Get off his boots and his blouse. Ephraim, heat water; the pail 's in the corner. Sue, bring that roll of linen you 'll find in the bottom drawer."

With deft, tender fingers, she worked over the wounded man.

"Bullet went clean through the shoulder," said the orderly, with a sigh of relief. "Good thing it was n't an inch lower!"

Carefully Miss Alida bathed the wound, binding it up with the soft linen. "That will do till we can get a doctor up here."

With careful hands, she spread the cherished coverlid over the wounded soldier. Her gaunt face had a strangely illuminated look. At last she was doing something for the cause she held so dear.

Slowly the soldier's eyes opened. For a moment he stared blankly, then his gaze fell upon Sue.

"Brave little enemy!" he whispered. He smiled faintly, then his eyes closed again.

"Is he going to get well?" asked Sue, anxiously.

"Of course he 's going to get well," said the orderly, reassuringly. "We could n't spare the lieutenant yet awhile."

Reaction having come, Sue with her head on Alida Grant's shoulder, sobbed out her heart. Alida's rough fingers stroked the soft hair tenderly.

"I reckon the coverlid 's twice as dear to me now," she said.

STILL through the summer days the troops in gray moved northward, followed relentlessly by those in blue. Then at last to Sue

and Miss Cecilia, anxiously waiting, came the tidings of Gettysburg—tidings softened only by the knowledge that Tom had passed unscathed through Pickett's heroic, but fruitless, charge.

In the cabin on the mountain-side, there was rejoicing, saddened by the realization of what the victory had cost.

"It 's the beginning of the end," said the lieutenant; "they can't hold out much longer. And I had to miss it!" he added regretfully.

The reason for his missing it brought to mind Sue Howard. "Poor little enemy!" he said pityingly. "This will be hard news for her, Aunty." And Miss Alida nodded sorrowfully.

Tenderly cared for, the wounded man was slowly gaining strength. From the plantation, sent by Miss Cecilia, had come Negro Ben, only to be relegated by Alida to the position of hewer of wood and drawer of water. No hands but hers should touch her soldier.

Almost daily came Sue to read to Mary's brother or to write the letters which he dictated to the folks at home. Sometimes she herself added a postscript to Mary. Often the lieutenant rehearsed to Alida the story of Sue's visit to camp.

"I 'll never forget the sight of the colonel's face as he saw the messenger, nor the dignity with which she demanded the coverlid. I fairly shook in my cavalry boots."

Sue only smiled at the teasing. "The colonel was a dear—that is, for a Yankee," she qualified.

"Anyway," continued the lieutenant, "I knew I *had* to find that coverlid; but I little thought that I would be lying beneath it so many weeks."

His hand touched it lightly, then he sighed

a little. The soldier found the forced inaction hard.

Miss Alida spoke. "When I think of that child's riding to camp and about your being wounded, all for me, it seems that my heart 's too full for words; but I reckon you-all know how I feel. And it does seem to me as if the coverlid was never so beautiful."

At last came the day when the soldier was able to ride away to rejoin his regiment. Alida and Sue stood at the gate to bid him farewell.

"I 'll never forget all your kindness, Aunty," he said, and bending, he kissed her cheek. Miss Alida flushed like a girl.

The soldier raised Sue's hand to his lips.

"Good-by, little enemy," he said smiling.

"Take good care of the coverlid."

Then from his pocket he took the little case containing Mary's picture and handed it to Sue.

"This is a reminder that sometime I 'm coming back," he said gravely. "Don't forget me."

Sue's face beamed as she took the picture. "I 'll just love it," she said. "When you do come back, bring Mary. I feel that I know her well already."

At something in the soldier's eyes as they rested on the young girl, Alida Grant smiled quietly.

Long years have passed since those summer days. More than half a century ago the coverlid was given to my grandmother as a wedding present from Alida Grant. The actors in the little drama have long since passed "beneath that low green tent, whose curtain never outward swings," but the coverlid still lies along the back of the old davenport, and with the passing years it seems to gather beauty.



BIG BETHEL  
CAINES MILLS  
MALVERN HILL  
2<sup>ND</sup> BULL RUN  
ANTIETAM



# THE MYSTERY AT NUMBER SIX

By AUGUSTA HUIELL SEAMAN

Author of "The Boarded-up House," "The Sapphire Signet," "The Dragon's Secret," etc.

## SYNOPSIS OF THE FIRST INSTALMENT

Two cousins, Sydney and Bernice Conant, living in the phosphate-mine region of South Florida, are fishing one day at an abandoned mine-pool, known as Number Six, when the boy is unexpectedly attacked by a hog-nosed snake and wounded in the hand. A strange girl of about fifteen, who looks almost like an Indian, appears from the bushes, draws the poison out of the wound, and binds it up temporarily. Before they can ascertain who she is, she disappears in the direction of an old farm-house at the other side of the pool—a house they had supposed unoccupied and deserted. Later in the day, in their own town, twelve miles away, Sydney learns from general gossip that the old house at Number Six is inhabited by the well-known half-breed Indian Everglades guide and his wife, and that they have with them a young girl about whom there seems to be considerable mystery. The guide, known as "Jerry Sawgrass," will disclose nothing about her, but says that she is his adopted daughter.

A few days afterward, the cousins visit the region again, bringing with them a box of candy for the girl of mystery, and hoping to learn something more about her. They have a curious and baffling visit at the old farm-house, entertained by Jerry's wife, a typical Florida "cracker" (as some of the backwoods natives are called), by Jerry himself, who is apparently far from well and who will say absolutely nothing, and by the girl, who is equally silent.

Later, however, after they have left the house, the girl reappears and begs them to come again, as she longs for companionship, but asks that they do not let the older people know of their visits, explaining that they do not wish her to see any outsiders. She calls the guide "Uncle Jerry," and does not appear to care for his wife. The cousins agree to meet her sometimes, and ask if they are to call her "Dell," as they have heard her addressed by Jerry's wife. To their considerable astonishment, she appears rather annoyed at this title and tells them that her name is "Delight."

## CHAPTER III

### MANY SPECULATIONS AND ONE CERTAINTY

IN the sweet-scented darkness of the hotel porch that evening, Bernice and Sydney discussed and re-discussed the strange happenings of the afternoon. Bernice and her parents were staying at the little hotel, temporarily, while a bungalow near that of Sydney's parents was being found for their occupation. A South-Florida phosphate town is a curious, mushroom growth, designed mainly for those engaged in the working of the phosphate mine or factory, and the most recent comers must always put up with the accommodations of the little hotel till their own bungalows are constructed or are vacated by departing occupants.

The two young people were much divided in their opinions in regard to their new acquaintance.

"But you can't deny that she's certainly very unlike those other two—that she lives with!" asserted Bernice, for the half-dozen time.

"Yes, she's different, I admit," replied the more cautious Sydney. "At least, she's very different from the 'cracker' woman. How different she is from Jerry, I can't tell, as he had so little to say. They tell me he's very intelligent, though."

"But what's the meaning of her being so

mysterious—and wanting us not to let them know when we come? I warrant they're not kind to her and she wants to get away from them—somehow." Bernice was a little irritated at Sydney's inability to see the thing from her point of view.

"If she wanted very much to get away, all she'd have to do would be run off and give herself into the hands of the authorities. If she could prove that they've ill-used her, or anything like that, no one would make her go back to them. No, if she wanted that, she'd have plenty of opportunity," replied Sydney, skeptically.

"But perhaps she does n't know enough—especially if she's lived in the Everglades all her life. Did you notice that she uses pretty good English?—very few grammatical mistakes. Where did she ever learn it?"

"That I can't figure out, unless Jerry is some sort of a scholar—which is n't likely. I know there are no schools in that wilderness, and not a soul lives there except the Seminole Indians—and they're an ignorant lot. They are the only really *wild* Indians left in the United States. Once in a while they come in to Miami or Fort Lauderdale, or even up to Kissimmee to trade, but most of them can hardly speak a word of English. No, that is a puzzle!" Sydney had to admit.

"Well, it is n't the *only* one, by any

means," insisted Bernice. "How do you account for the way she acted when you spoke of Jerry as her father? She was positively indignant, though she admitted that she called him 'uncle.'"

"Calling people uncle does n't mean a thing down South here. Every other old darky is uncle or aunt something-or-other! But anyhow, he's told people she was his niece, and it *may* be really true."

"I don't believe it!" cried Bernice. "She is no half-breed! She *has* dark hair and a dark, sunburned complexion, but her eyes are the bluest things I ever saw—perfectly beautiful! I'll never believe she has a drop of Indian blood."

"Then will you tell me how she came to be in the Everglades at all?" demanded Sydney, rather exasperated that Bernice should try to make a mystery out of what he thought could be so easily explained. "Her blue eyes may come from her white ancestry. *That* does n't prove anything. And no one but an Indian or a part-Indian, like Jerry, could possibly have lived in the Everglades all her life. So there!"

But Bernice chose to ignore this retort. "What do you suppose is the reason that they don't like her to have much to do with strangers?" she mused. "She even said they might move away if they thought she was trying to. That looks to me as if something was—well, *queer* about it. Don't you think so?"

"It may or it may n't be," acknowledged Sydney. "How do you know that the girl is n't rather queer herself and has sometimes made trouble for them by thinking she is n't treated just right and complaining of it to outsiders? I would n't blame them for putting some pressure on her—in that case."

Bernice, however, would have none of this argument. "You may be three years older than I am, Syd, and pride yourself on your common sense and superior judgment, but if you can't see that there is something strange in that whole situation, and that that poor little thing is n't a mischief-maker or an—an idiot—or anything like that, why—I give you up!" And she marched away in a huff. But she came back in a minute or two to add, "And she said her name was 'Delight.' Do you suppose a half-breed Indian ever gave her *that* name?"

"I notice they did n't *call* her that, anyway," Sydney conceded. "Cheer up, old girl! I did n't mean to discourage you—

really. But you must n't get a lot of romantic notions about an ignorant little Everglade 'cracker,' or Indian—or whatever she is! Tell you what, though!—I'm willing to play *Sherlock Holmes* with you as often as you fancy, if you think it worth while to run the truth to earth. We'll go over there to Number Six any time you say, and work it out after the most approved Sherlockian methods; only don't ask me to go and beard Jerry Sawgrass in his lair and forcibly demand that he present me with explanations! I draw the line at that. I fancy he could be rather formidable if he had provocation!"

"Oh, Syd—*will* you? There's nothing I want half so much—hunting down this mystery, I mean. It has just taken hold of me, somehow, and I can't get that poor little thing out of my mind. There was something so pathetic about her. When shall we go out there again?"

"Well, not *too* soon," conceded Sydney. "If we've got to use all these precautions against being seen, I'd rather hate to be found spying around there, in case everything did n't go right and Jerry got to prowling around, or anything like that. I don't like that feature of it any too much. It'd be right awkward! Let's put it off for a few days."

Bernice, in her impatience, found it very hard to wait and chafed at any delay. But the matter was decided for them—or rather, they decided it themselves, sooner than they had expected. On the following Saturday, about noon, Bernice rushed over to her cousin's bungalow and found him raking the live-oak leaves into neat piles in the sandy enclosure around his house. A mockingbird was lilting entrancingly near by, and the warm air was drenched with the scent of orange-blossoms. It was a heavenly day, but Bernice noticed none of these things.

"Oh, Syd!" she panted. "Guess what I heard—and saw! I happened to be in the general store getting something for Mother just now, and who should drive up, in the funniest old wagon drawn by a little, tired-out-looking mule, but—*Jerry Sawgrass and his wife!*" She paused to see the effect on her cousin.

"Well, what of it?" he demanded, unmoved. "I suppose they have to come to town sometimes—to get supplies. Was the kid with them?"

"No, she was n't," went on Bernice, breathlessly. "Jerry got out and came into the store and stood right next to me at the



counter. He did n't seem to recognize me at all, so I did n't say anything. He 's so queer that I did n't like to, anyhow. I heard him tell Mr. Caswell that they 'd come in town for the day. He wanted to get sup-

no earthly reason why we should n't go to that old mine-pool whenever we want to, anyhow. It is n't *their* property. I 'll take my rod and lines to fish, and you can chum around with the kid as much as you like.

As you say, it 's perhaps the best opportunity."

That afternoon, therefore, found them bowling along the asphalt road in the direction of Number Six, eager for their quest and all oblivious of the perfect Florida weather and surroundings. In the back of the car, Sydney had a couple of rods and his fishing-basket, and Bernice, a number of trifles that she thought would please the strange and lonely dweller at the deserted farm. The way had never seemed so long, and when they turned off the asphalt road of traffic and into the rutty, rough trail through the woods to the old mine-pool, it irked them sorely to have to slow down to ten or twelve miles an hour. It was two miles through the pine and scrub-palmetto and young live-oaks before they came in sight of the turquoise-blue water of the pool. Hardly had they stopped the car, when a little figure sprang out of the bushes.



"THE MISSIS' WANTED TO GO TO THE MOVING-PICTURE SHOW"

plies and 'the missis' wanted to go to the moving-picture show in the afternoon. They probably won't get back till six or seven o'clock in the evening—especially with that poky little mule. Here 's our chance, Syd! Let 's start right out in the car after the noon dinner and drive like mad over to Number Six. We can have the whole afternoon there without worrying about them. Don't you see?"

"All right," agreed Sydney. "There 's

"Oh, I thought you 'd come—I *knew* you 'd come!" she cried delightedly. "I was sure you 'd see *them*—in town—and know that I was here alone!" Her simple faith was so touching that Bernice had a moment almost of panic in imagining what the girl would have felt if they had had to disappoint her. "I 've been here watching for you—ever so long," Delight went on. It was curious to notice the difference in her manner—the lack of the restraint she had

shown in the previous visits, the simple pleasure in their mere presence.

"I'm going to fish," declared Sydney, with true tact. "You girls can amuse yourselves for a while, can't you?"

They joyfully agreed, and he strolled off to whip the blue, placid water with his long line, with more or less success. The girls, meanwhile, left alone, made rapid strides in getting better acquainted.

"Tell me," demanded Bernice, almost at once, "how did you dare tease that old alligator the way you did the other day? Were n't you afraid of him? You frightened me to death! But, by the way, he is n't anywhere around now, is he?" And she glanced apprehensively at the pool.

"Oh no!—he's down in the mud," smiled the girl. "I tried to pull him out all this morning. He would n't come. You need n't be afraid of him."

The ice being thus broken, Bernice drew from her companion amazing accounts of her encounters with rattlers, alligators, and other dangerous denizens of the wilds, all of which she recounted as if they were the most ordinary affairs! After that, the girl led Bernice off to a dense thicket, where she said she had something to show her, and, to Bernice's horror, exhibited a huge diamond-backed rattlesnake, coiled as if asleep. To her further horror, Delight coolly bent down and stroked it, and then a peal of laughter showed her amusement.

"It is nothing—see—only the skin! He left it there some time ago!"

Bernice sat down and gasped, weak with relief and astonishment. "You *are* a wonder!" she cried. "Is there anything you don't know about the wilds of Florida?"

"It's easy when you have grown up in them," answered her companion, but her manner immediately grew a trifle more evasive.

At this point, Bernice bethought herself of the things she had brought in the back of the car, and went to get them. "I had some things at home that I thought you might like," she said, half apologetically, and she presented her new friend first with a copy of one of her own favorite books. This was a wily move on her part, carefully thought out beforehand, for she wanted to discover, without direct question, if possible, whether the girl could read and where she had learned to do so.

Delight's eyes fairly sparkled when she saw the book and she seized upon it eagerly.

Opening it at the first page, she read the title aloud. "Oh, you're *good!*" she exclaimed. "I don't even own a book of my own. I have n't read anything—since—" she stopped abruptly, as if reflecting on the advisability of disclosing something, then went on boldly—"not since I—I went to school at Fort Lauderdale!" She seemed to think this a very damaging disclosure, for she halted again, as if in suspense.

"Oh, I thought you had lived in the Everglades all your life," commented Bernice, quietly, trying not to exhibit a sign of the excitement she felt at these revelations. "I have wondered how you managed to—to go to school."

"Fort Lauderdale is n't far from the edge of the Glades," explained Delight. "That year—it was three years ago—Uncle Jerry was taking parties through the Glades and our camp was on the New River, about five miles in from Fort Lauderdale. He was away so much, and I—I wanted so to go to school. There was a little school near the edge of the town. I begged Wanetka to let me go, and at last she said yes. I paddled there every day, five miles in the canoe. I learned very quickly—to read. That's what I wanted to do most. The teacher was good to me and gave me extra time. I could not go all the time, for Uncle Jerry would come back—and then I did n't dare. He—he did n't want me to learn. He can't read himself—he thinks it is a waste of time for me. Wanetka did not tell—he never knew. But at last we went back to our old camp—'way in the middle of the Glades. I never got another chance to go to school and I've never seen a book since!"

"May I ask—who was Wanetka?" asked Bernice, her curiosity at last getting the better of her caution.

"She?—oh, she was Uncle Jerry's Indian wife. She died a year after we were at Fort Lauderdale. She was very good to me. I—I loved her." A shade of sadness crept into her tones at the mention of this incident.

Bernice longed madly to ask her whether the Indian woman was a relative—whether Jerry Sawgrass was a relative—what the strange connection was, but she dared venture no farther along that line just then. She was too cautious to frighten the girl by demanding more confidences than Delight might choose to bestow. So she turned the conversation by presenting her other offerings—a box of home-made fudge and one of the latest magazines, profusely illustrated



and filled with interesting short stories. The gifts were received with a very passion of gratitude, apparent enough, though Delight was not very demonstrative in her expression of it. While she was poring over the pictures, Bernice sat longing—yet still scarcely daring—to ask some of the score or more questions surging through her brain. But before she had a chance, Sydney came hurrying over to them.

"I just want to tell you that the—er—that Jerry and his wife are driving back. I went toward the road a way and just happened to see them coming slowly, 'way in the distance, but I 'm sure it 's they. I don't know why they 're coming now. It 's quite early yet."

Instant consternation fell upon the two girls. Bernice wanted to fly and hide somewhere, and Delight got to her feet, swiftly gathering her new possessions in her arms.

"I 'll go away," she said, a little breathlessly. "Stay here, both of you. Just act, please, as if I had n't been here—as if you had n't seen me. There 's no harm in your being at this place—if I 'm not with you. And, besides, I want to—to hide these things in a place I have—for my own things. I don't want them to be seen—over there." She nodded her head in the direction of the house.

"Delight," said Bernice, suddenly and impulsively, "do you—are you so afraid of—of your uncle? Is he—well—unkind to you?"

The girl opened her beautiful eyes wide with unfeigned astonishment. "*Unkind to me! Oh, no! I—why I 'm very fond of him!*"

She motioned them a hurried good-by and slipped away into the undergrowth with the smooth and silent dexterity of which she seemed a perfect mistress. And when she was gone, Bernice and Sydney simply stared at each other with dropped jaws and blank expressions.

"Well!—*can you beat that last!*" exploded Sydney, at length.

## CHAPTER IV

### A NEW FACTOR

As things turned out, they did not even have to encounter the returning pair, who were so long in arriving that Sydney finally remarked: "Well, I don't know what 's keeping the mule-express, but I don't see any object in our hanging around here any longer. Let 's get in the car and drive out to the main road through that other trail that leads in here.

It is n't quite so good, but we can manage it, and there 's no sense in just *waiting* to be discovered."

This route they accordingly took; but so great was their curiosity as to the cause of the delay that Sydney got out, when they were a safe distance off, and went back on the main trail to reconnoiter. He returned in a few moments to say that apparently the cart had broken down about half a mile from the pool, and that when he had peeped through the bushes, he saw the cracker woman and Delight both trying to fix it up and Jerry sitting perfectly motionless and silent in the wagon. Evidently, from the little conversation he heard, the man had begun to feel ill while still in town and they decided to come home at once. Sydney said he would have liked to go and offer them some assistance, but concluded that the girl would only have been worried and embarrassed by it, so slipped away without being seen.

"So that 's *that!*" he finished, and Bernice occupied the journey home in retailing to him her half-enlightening and half-baffling conversation with Delight at the pool.

"It 's curious," commented Sydney, when she had finished, "but the more you learn about that situation, the more tangled up it becomes! I confess, I thought it pretty simple at first and that you were entirely mistaken in your guesses, but now I agree with you—it certainly is a puzzle!"

It is a very usual, but always surprising, experience, that once one has become interested in a new topic or event, dozens of fresh incidents in connection with it are always cropping up to confront one. So the two Conant cousins found it. Three days later, Bernice had a rather peculiar experience.

She was standing in the little post-office waiting for the mail to be sorted and the window to open. Ordinarily, she would have unlocked the family box, taken the contents, and gone away as quickly as possible, for she hated to linger about the rather untidy, stuffy little place. But she had forgotten the key and did not want to return home for it, so she leaned impatiently against the one writing-slab and listened in bored curiosity to the scraps of conversation going on about her. The office was crowded, for it was the regulation hour for the distribution of the morning mail, the great event of the day to the more idle population of the town and, indeed, to many of the inhabitants for miles around, who drove in especially for

the occasion. Village and local gossip was here retailed and ideas on every possible subject exchanged in the soft Southern drawl that Bernice always thought so fascinating. She found herself standing beside two typical cracker farmers, and presently as they

name is Jerry something-or-other) staring across the street an' heard him give a queer grunt. I looked ter see what *he* was lookin' at, an' theah was a gray-headed fellah in a Palm Beach suit—a reg'lah Yankee swell—a-gazin' at Jerry as if he 'd jes' got sight o'



"OH, I THOUGHT YOU 'D COME—I KNEW YOU 'D COME!" SHE CRIED DELIGHTEDLY"

talked a familiar name struck her ear. She suddenly found herself listening with absorbed interest.

"Funny thing happened in taown las' Sat'day," remarked one. "Yuh heah tell of it?"

The other responded with a grunted "Uh-uh!" which in Florida vernacular generally indicates "No!"

"Well, I *saw* it," the first went on. "That there half-Indian fellah was in taown—th' one they do say is out to old Number Six livin' theah now. He had his missis with him, th' one that come from down Okeecho-bee way. They wus jes' hittin' it up tuh have a gran' time—buyin' their tickets tuh go into the movies. I was right behind 'em. The line was cleah out inter the street. All on a sudden I saw that fellah (they say his

some 'un that owed him twenty dollars. The fellah started to come across the street, too; but jes' then a lot o' cyars come through an' blocked things up a bit, and when he got ovah an come up to the movie place, blest if that Jerry had n't beat it, jes' as *slick*, him an' his missis both, an' nobody seemed to know where they 'd gone. The other fellah looked around, sort o' dazed like, as if he 'd made a mistake, an' then he went off too. I seen him since—he 's staying down to the hotel. They say he 's got somethin' tuh do with the mines."

At this point the window opened and there was a rush to obtain the mail. The two gossipers drifted away, but Bernice stood stock-still where she was, rooted to the spot with astonishment at the new phase of things that had been suddenly opened up to her.



When the crowd had sufficiently thinned out, she obtained her own mail and hurried back to the hotel. It seemed an age before noon-time, the first opportunity she would have to see her cousin, for he was at present helping his father nearly every morning with office work in the phosphate factory. But at last the noon hour came, and Bernice, on the watch from the hotel veranda, signaled Sydney's car as it passed by on the way to his own bungalow. He got out, leaving his father to drive home, and joined her in a sunny, deserted corner."

"What 's the matter?" he demanded. "You look as if you 'd been 'seein' things'!"

"No, but I 've been 'hearin' things'!" she retorted excitedly, and retailed her experience in the post-office. "But that is n't all," she ended. "Do you know—that man is staying right here at the hotel!—there he is over there, reading the paper. His name is Mr. Tredwell. I 've tried to find out all I could about him this morning—in a quiet way. He 's down here transacting some law business for the mines, they say—came down from New York last week. Nothing apparently to do with Jerry at all. Now *what* do you make of it?"

"You can search me!" responded Sydney, looking thoroughly puzzled. "Looks as if Jerry was afraid of him, all right. But for what reason, goodness only knows! It may not have anything to do with the kid."

"But it certainly explains why they came back so soon last Saturday. And you say you heard the woman say he was ill—and, of course, it was n't so. They just did n't want Delight to know the real reason. Can't you see that?"

Sydney had to acknowledge that it looked that way, but was still skeptical that it might be for any reason that would affect *her*. "The man may know Jerry—may have had some dealings with him; perhaps he may have hired Jerry as a guide in the Everglades at some time or other, and Jerry may have proved dishonest or got away with something that did n't belong to him. Some of those guides and trappers are notoriously untrustworthy. And this Mr. Tredwell, seeing him, and perhaps recognizing him again, thought he 'd just come over and have an interview. It would be a very simple explanation."

"It *would* be simple, but it just does n't seem to me to fit," declared Bernice. "If that had been all, I believe Jerry would have 'bluffed it out' somehow. I 'm sure it would

take a good deal to make him so anxious to elude the man as he was very evidently doing. Now I propose that we go to see Delight again this afternoon and manage to see her alone somehow. Then we can just stop beating about the bush any longer and find out what is the matter and how we could help her."

"I don't see *why* you constantly take it for granted that she needs any help!" protested Sydney. "She 's an interesting little thing, and I admit that there are some puzzling sides to her case, but it 's none of our affair, after all, and I don't see why we should meddle in it." Sydney was planning a career as a lawyer, and certainly he was gifted with the judicial mind—infuriatingly so at times, in Bernice's opinion. "However, I 'll take you out this afternoon if you want to go." And in spite of all he said, Bernice shrewdly suspected that his own curiosity played not a little part in his acquiescence.

"After all, though," admitted Bernice, when they were on their way that afternoon, "I don't know how we actually *can* open the subject with her—do you? She 's awfully difficult to approach about anything concerning herself and those people."

"If you take *my* advice, you 'll let her alone on it. Perhaps something may come up that 'll open the subject without any trouble. It 's always better if it comes that way. I don't believe in forcing anything, myself." Having delivered himself of which sage advice, Sydney drove gravely on, keeping a weather-eye always out for the stray cows and pigs that make life a burden to the Florida motorist.

But the problem was again solved for them by what they encountered as they drew near the vicinity of the trail where they usually turned off the main road. To their immense surprise, they beheld, walking ahead of them and in the same direction in which they were going, the unmistakable figure of their new friend, Delight. With his foot on the accelerator, Sydney speedily overtook her.

"Hello! May we give you a lift? We were coming over to see you this afternoon."

The girl gave them a startled look, followed at once by a joyful greeting. "I must walk to a little store about five miles from here," she told them. "We 're all out of tea and flour, and Uncle Jerry 's too poorly to go. They did n't get all they wanted up to town the other day, and it 's too far to go

there. We—they sometimes get things at that little store.”

“Well, this is luck! Get right in,” cried Sydney, “and we’ll drive you there. It’s a shame for you to walk on this warm day, anyhow.” He got out and helped her into the rear seat, where she settled down rather timidly beside Bernice.

“I’ve—I’ve never ridden in one before!” she acknowledged, and fairly lost her breath at the speed which Sydney promptly put on. Bernice noticed that her dress was considerably tidier than when they had seen her before—she wore a clean middie blouse and her skirt was mended and brushed. Her dark hair, too, was smooth and orderly. It all created a subtle change in her appearance, transforming her from the wild little half-Indian, that she had first appeared, into a civilized and even well-groomed person.

“How nice you look!” was Bernice’s involuntary comment.

“I—I want to look nice—always!” declared Delight in timid appreciation of the compliment. “But it is so hard in—in the wilds there and when—no one else tries. Those books you brought me made me want to all the more—that and seeing and being with you. I’ve made up my mind that—

I’ll keep trying. But somehow—Uncle does n’t seem to like it. He—he does n’t understand!” This latter in an unusual burst of confidence. “I—I think it is because he does n’t read.”

Here was the very opening Bernice longed for, and she took advantage of it boldly. “How is it, Delight, that you wanted to read when no one else around you did—wanted it so much that you were willing to go all that way to school to—to learn. It has always surprised me.”

Immediately Delight went into her shell again, and Bernice felt that for once she had made a dreadful mistake. But a moment later the girl turned to her with a mysterious air.

“I’ve made up my mind to tell you something, Bernice. You’re the first friend I’ve ever had—the only one. Will you promise to keep it a secret?”

“May n’t I even tell Sydney?” whispered Bernice, breathlessly. “He’s so interested in you and I know he will never tell!”

“Well—yes, but not now—later. No one else—*positively*. The reason that I wanted to learn was because I’d found something—long ago—and I wanted to find out how—to read. I felt sure it would tell me something—about myself—about—*who I am!*”

(To be continued)

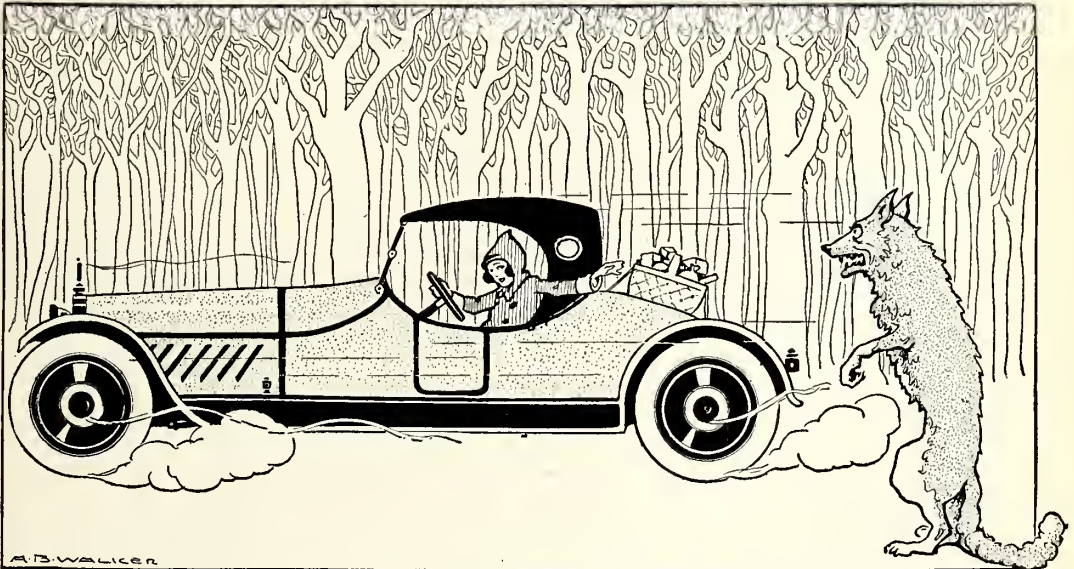

UP-TO-DATE: LITTLE RED RIDING HOOD MOTORED BY, A MERRY TWINKLE IN HER EYE, THE OLD WOLF GLARED AS HE GROWLED BACK, "I'D GIVE ANYTHING FOR A TACK!"





Photograph by Brown Brothers

A FEDERAL BUILDING—THE CUSTOMS HOUSE AT NEW YORK CITY

## GOVERNMENT-OWNED BUILDINGS—WHICH OWNS WHICH?

By C. MITCHELL TALIAFERRO

My Uncle John says life reminds him of the game we kids play called "Plain Sight." He says people are all the time looking in all sorts of out-of-the-way places for interesting things, when the things of interest are right in sight, if they only had "gumption" enough to see them. I asked him to tell me some of them, and he said, "Well, that building over there"—we were walking down the street—"is the city hall. That is interesting." I said I did n't see anything interesting about the city hall; it was just a big building—not even pretty. Then he bet me that I did not know who owned it; and after I stuttered and hesitated and mumbled something, I finally said, "The Government." He laughed and said: "That 's a good guess. You made a 'stab' at it, anyway, but what branch of the Government?" Then I said I did not know what he meant by "branch of the Government." So he began to tell me, and I was so interested in what he said that I listened to every word. Uncle John certainly is smart. What he told me was this:

He said the Government in this country is divided into four main branches: the City; the County; the State, and the Federal, or United States, Government. Each one of these branches has a head person, called the executive, who sees that the business is attended to and the laws enforced; and, just as any other business needs to have an office, so the government business has to have an office. Uncle John says every city has a city hall where the mayor has his office, and where the council meets, and where the heads of the departments of the city have their offices; and this building belongs to the city. But, he said, that is not the only building the city owns, for all the fire stations and police stations and the city jail and all the public-school buildings belong to the city. And some cities have hospitals and libraries and museums and other things. "So," he said, "you see the city is quite a property-holder."

Then I asked him how the city got the money to pay for the buildings, and he said

all the money used for running the city was got from the taxes which the citizens paid and which made everybody really have an interest in these public buildings. I then asked him if the court-house belonged to the city; and he said no, that belonged to the county. Then I asked him to tell me about that.

"Oh, you 've found something interesting in these buildings, have you?" he asked with a laugh.

I told him that I certainly had, and wanted him to tell me all he knew about them. He laughed again and said he would n't tell me all he knew, but would tell me enough to set me to thinking about them, and I would find out more for myself all the time, now that I had become interested.

He said the county was a division of the State, and had in it cities and villages and hamlets, but the laws of the city and the laws of the county did not conflict. I asked him what that meant; and he said it meant that if you disobey a county law, the police could n't get you, but the sheriff would; and if you disobey a city law, the sheriff would n't get you, but the police would. He said

that the county judge is the head of the affairs of the county, and is aided by commissioners, who look after certain parts of the county, called districts. And there are a great number of records of business transactions which have to be kept, and quarrels between people have to be settled, and taxes have to be paid, and all kinds of things like that; so a building is needed to keep the records of these things, and that building is the county court-house. The court-rooms are in this building, as well as the business offices. The county has other buildings besides the court-house. It also owns schools, hospitals, and a jail. Uncle John said the people in the cities who pay city taxes pay county taxes too, and so have an interest in the court-house as well as the city hall and the other buildings; but he said there are a number of people who live in counties who do not pay city taxes, so they have no interest in the city buildings, only those of the county. Then he said, "But both the city and the county tax-payers pay state taxes, so all have an interest in the state buildings."

I told Uncle John I thought all boys and girls ought to know about these things, and



Photograph by Brown Brothers

STATE HOUSE, BOSTON, MASSACHUSETTS



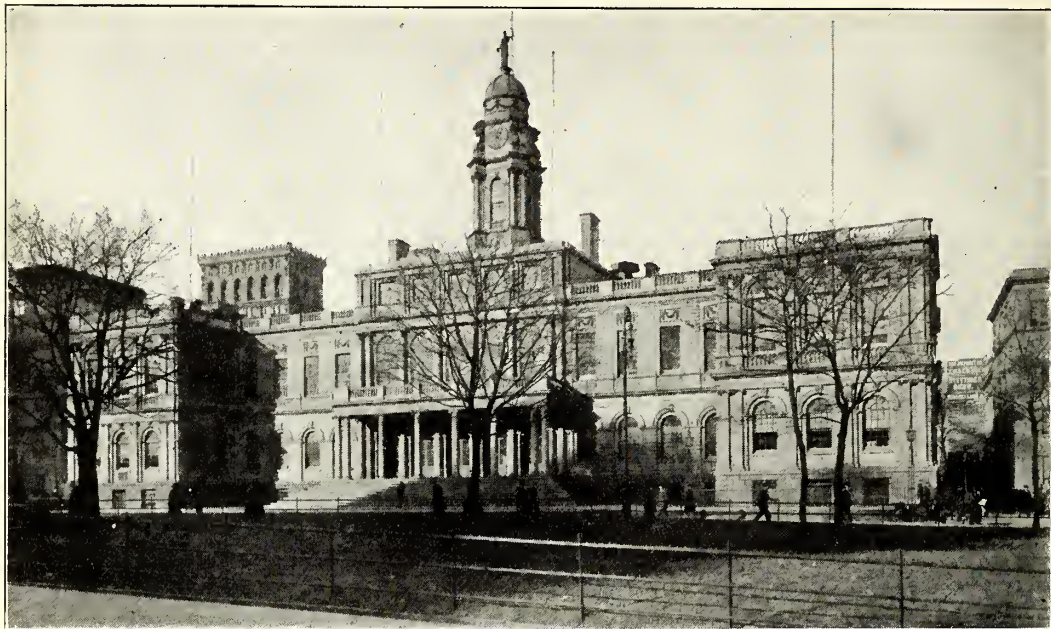

Photograph by Brown Brothers

THE CITY HALL, NEW YORK CITY

he said he thought so too. Then I asked him to tell me about the state buildings.

He said the main government building

the State's business. The state university, and the buildings which belong to it, are owned by the State, and some States own other

kinds of buildings as



Photograph by John Rosch

WESTCHESTER COUNTY COURT-HOUSE, WHITE PLAINS, NEW YORK

owned by the State is the capitol. This is where the governor has his office, and where the halls of legislature (where the laws are made) are, and the different departments of

well. There is always the state prison and state insane asylum, and some States have experimental farms, where there are large buildings. While the States do not own the county court-houses, the state taxes are paid there for the convenience of people, as Uncle John said. All the people pay state taxes, and it is easier to get to a county court-house than to get to the state capitol or send your money there.

I then asked him about the Federal Government buildings, and he said that the Federal Government, which is the Government of the whole United States, has its buildings all over the country. I told him that I thought they were in the city of Washington, in the District of Columbia; and he said no, only

the main buildings were in Washington. He said the post-office department and the legal department and the revenue department have to have offices in all parts of the country. Every post-office belongs to—or is leased by—the Federal Government; and at ports where goods come from foreign countries, and on the borders of Canada and of Mexico, there are custom-houses, where import duties are paid; and these buildings belong to the Federal Government. The life-saving stations, the lighthouses, and all of the buildings at all of the army posts, and the Military Academy at West Point and the Naval Academy at Annapolis belong to the Federal Government. There are several Federal prisons in the country, and quarantine stations, which are Government owned.

I was certainly glad Uncle John told me about these different buildings, for it is always so much easier to remember what any one tells you than what you study out of books. I hope he will tell me some more things like that, for it is just as he says: there are so many things "in plain sight that people do not see." He said if I would notice, I would see that all city halls, all court-houses and all capitol buildings look somewhat alike.

This is because these edifices are used for the same kind of business, and the type of building chosen is best for the purpose.

Now, when I visit another city, I shall be interested to see the city hall and other buildings, and I am going to try to pick out the Federal buildings, too.

## THE CAMPANILE

By KATHRYN HULBERT

(Written at the age of fourteen)

ABOVE the thronging city, towering high,  
The Campanile lifts its stately crown.  
By day, by night, this guardian tower keeps watch  
O'er busy mart, the hum of trade, the stream  
Of life that pours from court and school and shop.  
The gleaming river, winding from the north  
To southward flows; and, circling far around,  
The hills their rampart walls uplift to bound  
The quiet landscape, dotted hamlets here  
And there, and church-spires pointing to the  
skies.

And where the river brings its message from  
Afar, breaks through the barrier of the hills,  
Mount Tom and Holyoke stand like ancient  
forts

To guard the peaceful valley, spreading wide.  
Below, the legendary Agawam  
Winds through its shaded meadows, serpentlike,  
While stately elms cast shadows on the green.  
Where Indian maidens once did dance and sing  
Weird strains with minor cadence, sad and slow.  
And at our feet the ancient bridge, well-trod  
By generations past, still stems the tide  
Of old Connecticut; upon its banks  
The chimneys rise, beneath which turn the wheels  
Of many a world-wide industry; and sharp  
Upon the ear, the noisy engine puffs  
Along the shining rails and brings and sends  
The fruits of commerce near and far; and up  
The terraced heights, the myriad homes mount,  
step

By step, mid cool and fountain-gushing parks  
Which mark the site of palisades of old  
Where once rang out the shouts of Indian war.  
Then nightly, as the stars shine out, this tower  
Keeps watch above the sleeping multitudes.  
While thus the seasons come and go, with blasts  
Of winter, bursts of sunshine, flowers of spring,  
The Campanile slumbers not nor sleeps,  
But ever watches, spectral—calm—serene,  
A mighty landmark in a mighty land.



THE CAMPANILE AT SPRINGFIELD, MASSACHUSETTS



# HOW BOYS PLAY GAMES BY RADIO

By WILLIAM TELHER

PLAYING games by radio is the newest sport. The boys in and around New York City, who have small radio-telegraph sets, are having a great deal of fun nowadays in carrying on contests and tournaments through the air. Folks who are listening in hear conversations like this:

"It 's your move, John. I just jumped from twenty to twenty-seven."

A" and Tom's station "Station B." A sets all the checkers up on his board and B does the same with his. A complete set of checkers must be used in each instance. Before the game is started, the spaces on the checker-board are numbered. This is done by starting from the lower left hand corner and numbering from left to right until the uppermost corner is reached. This can be

easily done with figures cut from old calendars.

Let us assume that A starts the game by making the first move. A "radios" to B and tells him that he moved one of his men from space 9 to 13. He does not take the trouble to make a lengthy explanation, but simply says, "9 to 13." When B receives this he goes over to A's side of the board and moves A's checker from space 9 to 13. He then studies the game, makes his own move, and radios back to A. A then makes B's move on his board and prepares to move his own. In this way, each player is kept informed of the progress of the entire game. If the game progresses well, it will



CHESS CAN BE PLAYED BY RADIO

"All right, Tom; I 'm moving from ten to fourteen."

If we did hear a conversation like this, we should at once know that a game of checkers was being played. Checkers is only one of the many games that lends itself to radio. Playing radio checkers is just as easy and almost as fast as playing the game in the ordinary manner. In fact, it is more exciting than the usual game, because we are always playing an invisible opponent.

To play checkers, we must have two boards. Let us assume that John Jones on one side of the city wants to play with Tom Smith on the other side. For convenience' sake, we will call John's station "Station

be found possible to play it within the space of a half-hour or so.

When a man is jumped, the move is transmitted in this way: "Twenty to twenty-seven, jump one."

If A should reach B's king row, this is heard: "Twenty-three to thirty-two, king."

Many boys may think that checkers can not properly be played by radio because of the possibility of making false moves. This is not so. It is, in fact, quite impossible to do this, for if a move is made and not correctly reported to the other player, he is sure sooner or later to find it out, as you can readily see must be the case.

Chess can be played just as easily as checkers. Two boards are numbered and

used in the same way. If the players understand the game well enough, they can get along without numbering the chess-board.

There are few games that can not be played by radio. This is especially true of the class of games where the moves are determined by operating a little spinner. One of the latest games of this kind is that called "Bringing Up Father." If each contestant has one of the games, as many as two people can play at each station.

Every time a move is made, it is radioed to the other station and the same move is made on that board. In this way, the various positions of the players are known at all times.

This, of course, calls for a high degree of integrity on the part of the players, but the average American youngster can, we know, be trusted always to "play fair."

Playing games by radio should appeal to every boy with a wireless outfit. It will afford him bushels of fun that he never



"PLAYING RADIO CHECKERS IS JUST AS EASY AND ALMOST AS FAST AS PLAYING THE GAME IN THE ORDINARY MANNER"

thought of before. And, in addition to the fun afforded, there will be the increase in skill in playing the games and in operating the radio set.



"'BRINGING UP FATHER' CAN BE PLAYED BY AS MANY AS TWO PEOPLE AT EACH STATION"





**H**E was a pirate, Francis Drake,  
As the dons complained, while  
his laugh would shake  
The throne of Philip; a buccaneer  
Who filled the winds of the world with fear.

Drake's red beard was a flaming fuse  
From Nombre de Dios to Santa Cruz;  
A fiery dragon, his wrath would swoop  
On Valparaiso and Guadaloupe;  
Terror of Drake swept the Golden Main  
To Cadiz, the "Silver Cup" of Spain.  
He circled the globe like a burning snake,  
Master-thief for England's sake.



The glistening harvest Spain's flail  
had threshed  
From the Indian Islands, all enmeshed  
In her bitter bondage,  
this pirate stole  
With a crimson hand  
and a singing soul—  
More bars of silver  
and creels of gold,  
Pearls and gems  
than his boats could  
hold.

Hesacked their cities;  
he fell upon

Their mule-trains, heavy with treasure won  
From tortured Incas of rich Peru,  
And, sudden as scream of the cockatoo,

Had stricken and slain and plundered—gone  
Before their eyelids were well awake,  
Before their weapons were well aware,  
Till never a grove of cinnamon  
Nor listening, fronded forest where  
Golds and greens were interblent,  
As sun and shadow came and went,  
But shivered for dread of English Drake!

He loved his ships like daughters and sons;  
His first, the *Judith*, of fifty tons,  
The *Dragon*, the *Pasha*, the *Christopher*, *Swan*,  
The *Marigold* sea-swallowed and gone,  
And the little dancing *Pelican*,  
Who came limping home, as the *Golden Hind*,  
By the road Magellan died to find,  
Having traced her course in flashes of foam  
Around the globe; a wonder of ships,  
Stumbling, staggering, straining home  
To her own white cliffs, like a wounded gull,  
To be flocked to and famed till her ancient  
hull  
Was whittled away into sacred chips.

He loved his ships, and he lived aboard  
Like a king of the waves, a ruffling lord  
In silk and pearl, while his Devon crew  
Flaunted in scarves of scarlet and blue.  
His cabin was tapestried; sprinkled his dress  
With perfumes, a present from blithe Queen  
Bess.

In platters of silver-gilt displayed  
Were his banquets—comfits and marmalade  
And fruits of the tropics to season the fish;  
His arms were graven on every dish.





**H**E drew out his knife from a velvet sash;  
With napery fine, from his red mustache,  
He wiped with a flourish the drops of sack;  
While in carven chair he flung him back,  
To repose his soul from its slashing sins  
On the music of flutes and violins—  
A pirate prouder than mandarins.

Up the green sea's hills, down the green sea's valleys,  
His keen ships coursed King Philip's galleys,  
And set their teeth, when the chance befell,  
In Portuguese carrack and caravel.  
Foemen he fought, and roaring seas,  
Wreck and wounds and foul disease;  
Made his haughty gentlemen haul  
With his mariners; clamped his will on all.



**H**

esailed and "sing'd King Philip's beard,"  
 While the council of England fretted and feared.  
 Like a thunderous cloud, Spain's vengeance loomed;  
 The king demanded the pirate's head;  
 His dark ambassador frowned and fumed  
 Till the eyes of Albion's queen flashed red;  
 It was not in her Tudor heart to forsake  
 That whirling firebrand, Francis Drake.

Well for the pirate the ship of state,  
 In that tense hour of England's fate,  
 Had a woman's hand at its gallant helm—  
 A woman's hand, but a wrist that yet  
 Throbb'd with the pulse of Plantagenet.  
 He whose deeds had imperiled the realm  
 Knelt at her feet, alive or dead

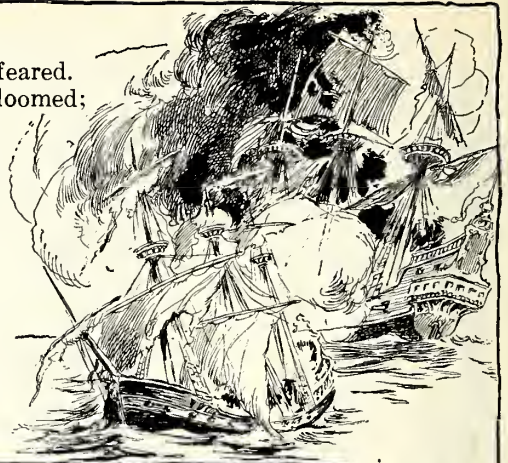
**A**

s her voice should doom—a voice unheard  
 For one long minute, while Queen Bess toyed  
 With a light, gold-hilted, gem-set sword,  
 Whose shifting blade strange dazzle shed  
 Upon that wary, weathered head,  
 Bowed with a courage unalloyed.  
 (For what was a queen to a hurricane?)  
 The hushed court hearkened for her word.  
 The eyes of the fierce grandee of Spain  
 Glowed with a threat behind the hate.  
 One's heart could hear the centuries wait  
 While the queen pondered on many things—  
 Treaties and snares and the smiles of kings,  
 The flash of a cutlas that dared to break  
 The web that entangled her kingdom—Drake,





**A** PIRATE, a pirate for England's sake,  
A pirate of pirates, a master-thief  
Who had spoiled the spoilers! Logic enough;  
A woman's statecraft is shimmering stuff,  
Spun of the spirit. Soft as a leaf  
The steel touched his shoulder and Destiny spake,  
Destiny borne on a woman's breath,  
In the vibrant voice of Elizabeth:  
"I bid thee rise, *Sir Francis Drake!*"





# A VISIT TO DRAKE'S BAY

By J. SMEATON CHASE

FOR many years a lively discussion was waged among geographers and historians as to the place on the shores of California where Sir Francis Drake made his landing in the year 1579, in the course of his famous circumnavigation. It used to be generally believed that the "fair and good bay" into which "it pleased God to send us," to quote from the narrative of Francis Pretty, one of

latitude. The photograph shows the general features of the scene, and it will be noticed how well they agree with the account of the "white banks and cliffs which lie toward the sea," which gave occasion for the name of Nova Albion, given to the region by the far-wandering Englishmen in memory of the chalk cliffs of their native land. Far to the west I could see the rocky headland of Point



DRAKE'S BAY, THE PROMONTORY OF POINT REYES IN THE DISTANCE

Drake's gentlemen-at-arms, could be no other than the great bay of San Francisco; and in some histories of the United States it is plainly stated that Drake there refitted his ship before continuing his westward voyage. But in the thorough thrashing out of the subject by those interested in such matters, it has come to be accepted as certain that it was not in San Francisco Bay, but in what is now known as Drake's Bay, some twenty-five miles to the northwest of the Golden Gate, that the little *Golden Hind* took her well-earned five weeks' rest.

The picturesque incidents of the Englishmen's stay, as related by Master Pretty, came vividly to my mind when, in the course of a horseback journey up the coast of California a year or two ago, I rode out one afternoon upon the lonely cliffs of the bay—about the most solitary spot, I think, in all that long coast-line of nearly ten degrees of

Reyes; and twenty miles to the south I caught a hazy glimpse of the desolate islets of the Farallones, named after the pilot of Cabrillo's expedition of 1542, the first voyage made by civilized men along the northwest Pacific seaboard.

I would have given a good deal to be able to know the exact spot where Drake pitched his "fenced place," and where the king of the country, "who marched to us with a princely majesty," made supplication "that he (Drake) would take their kingdom into his hand and become their king."

And what a find it would be, I thought, if I might come on traces of that "monument of our being there, as also of her Majesty's right and title to the same," set up by Drake at his departure—"namely, a plate, nailed upon a fair great post, whereupon was engraved her Majesty's name, the day and year of our arrival there, with the free giving

up of the province and people into her Majesty's hands, together with her Highness' picture and arms, in a piece of sixpence of current English money, under the plate, whereunder was also written the name of our general." I wished I might camp for a night on this historic ground; but time forbade; and as the sun sank in a glory behind the arm of the bay, I repeated to myself the stirring lines of Sir Henry Newbolt's poem, "Drake's Drum":\*

Drake, he 's in his hammock, and a thousand miles away

(Captain, art thou sleeping there below?),  
Slung between the round-shot, in Nombre Dios Bay,

And dreaming all the time of Plymouth Hoe.  
Yonder looms the lighthouse, yonder lie the ships,  
With sailor lads a-dancing, heel and toe,  
And the shore lights flashing, and the night tide dashing—

He sees it all so plainly as he saw it long ago.

Drake, he was a Devon man, and ruled the Devon seas.

(Captain, art thou sleeping there below?)  
Roving though his death fell, he went with heart at ease,

And dreaming all the time of Plymouth Hoe.  
"Take my drum to England, hang it by the shore;  
Strike it when your powder 's running low.  
If the dons sight Devon, I 'll quit the port of Heaven,

And we 'll drum them up the Channel as we drummed them long ago."

Drake, he 's in his hammock till the Great Armadas come

(Captain, art thou sleeping there below?),  
Slung between the round-shot, listening for the drum,

And dreaming all the time of Plymouth Hoe.  
Call him on the deep sea, call him up the Sound,  
Call him when ye sail to meet the foe.

Where the old trade 's plying and the old flag 's flying,

They shall find him ware and waking, as they found him long ago.

\* Reprinted by courtesy of John Murray, London.

## THE TURNER TWINS

By RALPH HENRY BARBOUR

*Author of "The Crimson Sweater," "The Mystery of the Sea-Lark," etc.*

### SYNOPSIS OF PREVIOUS INSTALMENTS

WHEN the Turner Twins enter Hillman's School in the autumn, neither knows much of football or baseball, but they consider it their duty to aid the school, so Ned joins the football candidates and Laurie goes in for baseball. With the aid of "Kewpie" Proudree, center on the team, Ned conceals his ignorance and by hard work makes the scrub and develops into an excellent goal kicker. Bob Starling, a day-pupil, lives in the Coventry house, which his father has recently rented. The house is a place of mystery, its former owner, an eccentric old miser, being supposed to have hidden somewhere about the premises money that at his death, four years before, could not be found. Bob obtains permission to tear down an old arbor in the garden behind the house and make a tennis-court there. One afternoon, Polly Deane, whose mother keeps the little tuck-shop behind the Coventry place, and Mae Ferrand, her chum, accompany Laurie Turner and three other boys on a nutting excursion. The talk turns to "spooks," and Polly tells of strange noises heard at night in the shop which sound as if they came from the cellar; only, as Polly adds, there is n't any cellar!

### CHAPTER XVIII

#### Laurie Makes a Protest

THE football team continued to add victories, and as the fateful twentieth of November approached, enthusiasm grew until, after the Whittier game, which Hillman's won by a field-goal in the final hectic two minutes, it became more a furore than enthusiasm. Ned, by that time, had settled down to a realization that, no matter what progress he made that autumn, no matter

how adept he became at kicking a football down the field or over the cross-bar, he would not make the first team; that, in short, he was being educated as next-year material. There was no injustice in this, and he realized it; for, aside from his proficiency as a kicker, he was not in the class with the school team backs. He could n't worm his way through a hole in the opposing line the way Slavin could, nor smash through the defense the way Mason did, nor dodge and side-step in a broken field like Pope. Once going,



Ned was rather hard to stop, for he displayed some of the slippery qualities of an eel; but it took him ten yards to get his speed up, and the opponents had a discouraging way of getting through and flooring him before the tenth yard was won! But he had grown to love the game, and no one toiled more conscientiously. There were times when Laurie devoutly wished that Ned had n't taken up the game, for, after a half-hour of Ned's chatter, Laurie found the subject of football a trifle dull.

On the Wednesday before the Farview contest, the Orstead High School team came over for a practice game. At least, Hillman's called it a practice game and considered it such; but High School had blood in her eye and was secretly determined to wreak all the vengeance possible. Once a year, for the space of some three hours, Orstead High School swore allegiance to Hillman's and turned out at the field and rooted valiantly for the Blue while she battled with Farview. But all the rest of the time she was frankly hostile and derisive. This Wednesday afternoon the hostility was apparent from the first. More than a hundred boys and a scattering of girls followed their team to the Hillman's field and demanded revenge for the early-season defeat, while the high-school team, which had passed through a rather successful season and was not at all the aggregation that the Blue had beaten 10 to 7, started right out after it.

Coach Mulford began with his first-string players; and against them, High School was not dangerous, although there were anxious moments. The second period ended with the score 7-0 in Hillman's favor, only a fumble by Slavin on High School's eight yards saving the visitor from a second touch-down. When the third quarter began, Coach Mulford put in a nearly new eleven, only Kewpie Proudree, Farley, Mason, and Pope remaining over. Perhaps the high-school coach had talked new strength and determination into his charges during the intermission, for the visitors started in on the second half in whirlwind fashion. The Blue kicked off, and High School's quarter got the ball on his twenty-five-yard line and scampered back to the thirty-five before he was laid low by Farley, the Blue's left end. From there, with fierce slams at Hillman's right and two short forward passes over the center of the line, High School reached the opponent's thirty-two. There an off-side penalty set her back, and, after two attempts at

rushing that produced but three yards, she kicked to the five-yard line. Kendrick fumbled the catch, but recovered and was downed on his ten. Pope punted on second down to mid-field; and from there, High School started another slashing advance that took her to the thirty-four yards before she was halted.

On the side-lines, the high-school supporters were shouting and beseeching and banners were waving deliriously. A tow-haired full-back, who had all along proved the visitor's best ground-gainer, smashed through the Hillman's left for two yards; and then, on fourth down, faking a kick, he set off on a romp around the adversary's right. Lightner, the second-string end, was effectually boxed, and the runner, turning wide, was off down the field at top speed. Only Hop Kendrick stood between him and the goal-line, and Hop waited on the fifteen yards, wary and alert. The tow-haired boy's feint to the right did n't fool him, and when the side-stepping to the left began, Hop was on him with a clean dive and a hard tackle, and the two rolled to earth together. But the ball was on the thirteen yards now, and it was first down for High School, and the latter was not to be denied. A plunge off tackle took the pigskin in front of the goal, though there was no gain. Hillman's piled up an attack at right guard. On third down, High School called for kick formation, and the tow-haired terror dropped back.

From the side of the gridiron, Hillman's rooters chanted: "Block that kick! Block that kick!" But there was no kick to block, for the full-back only backed away a pace or two when the pigskin reached him, and then tossed to the corner of the field and to the eager hands of an uncovered right end who had but to make three strides before he was over the line. Hop got him then; but the damage was done, and the visitors lining the gridiron were cheering and cavorting wildly. The kick was from a difficult angle, but the tow-haired player made it, and the score was tied.

The teams changed fields a minute later. Undismayed, Coach Mulford sent in three new substitutes, one of them in place of Pope. Hillman's got the ball in mid-field on a fumble, and set off for the adversary's goal; but the new players were not able to make much headway, and Deering, who had taken Pope's place, punted. The effort landed the ball on High School's thirty-seven, and her quarter ran it back eight

more before he was stopped. Three tries at the line netted seven yards, and the visitor punted to Hop Kendrick on his eighteen. This time Hop hugged the ball hard and set off along the far side of the gridiron at a smart pace. Fortunately for him, one high-school end overran. The other challenged, but missed his tackle. By that time, a hasty interference had formed, and, guarded by Mason and Lightner, Hop reached his forty before misfortune overtook him. There a high-school tackle crashed through the interference and nailed him hard.

But that twenty-yard sprint had brought new vim to the Blue's novices, and new confidence, and from their forty yards they began a fast, hard attack that placed High School with her back to the wall almost before she realized it. If the substitutes lacked the experience and brawn of the first-choice players, they at least had sand and speed. And they had a quarter-back who was earnest and grim and determined, and who, sensing that the opponent was weary, realized that speed, and a lot of it, was the one thing that could save the day. And so Hop proved his right to his nickname that afternoon. Hop he did, and so did his team. Signals were fairly shot into the air, and there was no longer any time between plays for High School to recover her breath. Twice, with plunges at the right of the visitor's line and runs outside her tackles, Hillman's made her distance, and the pigskin rested on the thirty-six yards.

So far, the Blue had attempted but three forward passes, of which only one had suc-

ceeded. Now, from position, Hop threw straight over the center, and somehow Lightner was there and pulled it down, although the enemy was clustered around him thick. That seven-yard gain was made twelve



"THEN THERE WAS A CLEAN, HARD THUD" (SEE NEXT PAGE)

when Deering was poked through the center, and the ball was down on High School's twenty-four-yard line.

The game that had been proclaimed a practice event for the purpose of seasoning the substitutes against Saturday's contest had developed within the last half-hour into a battle to the death. Outside the gridiron the opposing factions hurled defiant cheers at



each other and rooted as they had not rooted all the season. On the field the rivalry was even more intense, and black looks and hard knocks were the order.

High School, sparring for time, administered to a breathless right guard, and then drew into a bunch for a whispered conference, while Hillman's supporters hooted derisively. Deering gained three and Boessel two more. High School ran two substitutes on, and, after the next play, two more. An old-fashioned crisscross sent Mason around his own right end for eight yards and planted the ball just short of the ten-yard line. Mason gave place to Beedle. A slide off tackle centered the pigskin and gained a scant yard. Deering struck center for a yard loss, and Lightner was caught off-side. The ball went back to the seventeen yards.

High School was playing desperately and her line had stiffened. Beedle gave way to Ned after that second down, and Ned had his instructions. The ball was in front of High School's goal, and from the seventeen yards a field-goal was an easy proposition if the opponents could be held away from the kicker. Perhaps Hop Kendrick did not realize why Ned had been sent in, or perhaps he thought better of his own judgment. Since by the rules Ned could not communicate the instructions from the coach until after the following play, he could only look his surprise when Hop failed to call him back to kicking position. Farley, captain in Stevenson's absence, seemed to be on the point of protesting, and even took a step toward the quarter-back; but he evidently reconsidered, for he returned to his position at the end of the line, and the starting signal followed.

The play was a fake attack on the right, with Boessel carrying the ball to the left inside of tackle, and it worked to perfection. High School, over-anxious, stormed to the defense of her threatened right side, and Boessel, with Ned hanging at his flank as far as the five-yard line, where the earth suddenly rose up and smote him, romped over the line for the last and deciding touchdown, while the Blue cohorts went fairly wild with delight.

On the side-line, Coach Mulford turned to Joe Stevenson. "What do you think of Kendrick?" he asked, smiling.

"I'd kiss him if I had him here," answered Joe, grinning joyously. "I call him one sweet little quarter, Coach!"

"Well, this was his day, all right," mused the other; "I hope he will show up as well

Saturday. Now we'll see whether Turner can kick a goal. He's been doing some good work in practice, but he looks scared to death and will probably miss it by a mile."

And Ned was scared, too. He tried to steady his nerves by assuring himself that, whether he made it or missed it, the Blue had won the game, and that consequently a failure made little difference. But the silence of his schoolmates and the "booing" of the visiting rooters affected him badly. To Hop, holding the ball from the turf, it seemed that Ned would never have done pointing it. And so it seemed to the on-lookers. Never was a kicker more deliberate. But at last Hop heard a faint "Down!" and drew his fingers from beneath the oval, and waited an anxious moment. Then there was a clean, hard thud, and the quarter-back, watching its flight, saw the pigskin rise lazily, end over end, and go straight and high over the bar.

And he might have heard Ned's loud sigh of relief, had not the pounding of the charging enemy and the cries of the Hillman's horde drowned it.

Another kick-off and four plays ended the contest, and High School, after cheering half-heartedly, went off disgruntled and silent.

On his way to the field-house, Ned, trotting along with Hop, encountered Polly and Mae in the throng and paused to speak. "Bully game, was n't it?" he said. Then, seeing Mae's high-school banner, he added: "High School put up a dandy fight, Mae." "Indeed she did," agreed Mae. "I thought once she was going to win, too."

Polly was laughing. "Poor Mae did not know which team she wanted to win," she explained. "When High School gained she waved her flag, and when Hillman's gained she waved it just the same. She was waving it all the time! That was a lovely goal you made, Nid."

"Thanks. I—well, I was so scared I did not know whether to kick the ball or bite it! I'm mighty glad it went over, though." He nodded and hurried on in the wake of Hop, who, being a very earnest young gentleman and completely absorbed in the business of football, considered girls far outside his scheme of things.

Three quarters of an hour later, Laurie arose from his recumbent position on the window-seat of Number 16 East Hall and delivered an ultimatum in quiet, but forceful,

tones. "Ned," he said, "I saw that game from about the middle of the first quarter to the bitter end. Nothing escaped my eagle gaze. I can even tell you exactly how many times that high-school umpire consulted his rules book when he thought no one was looking. I know how much dirt there was in Frank Brattle's left ear when they dragged him out. I know—"

"Well, what of it? What 's your chief trouble?" growled Ned.

"Knowing all this and more, much more, Neddie, I refuse to listen any longer to your reminiscences. You 've been through the game three times since you landed up here, and there 's a limit to my endurance. And you 've reached that limit, Neddie—you really have. I 'm going down to George's, where I may hear something besides touch-downs and passes and goals. When you recover, Neddie, come on down."

"Oh, go to the dickens!" muttered Ned, as the door closed softly.

## CHAPTER XIX

### BEFORE THE BATTLE

"THE fellow who put these posts in," grunted Bob, as he heaved and tugged, "must have had more time than brains!"

It was Thursday afternoon. A hard frost, which had frozen the ground a half-inch deep, had counseled him to finish the work of wrecking the arbor. But three posts remained, and at one of these Bob, after having dug around it and pried at it with a bar until patience was exhausted, was tugging lustily. Laurie, wiping the sweat of honest toil from his brow, cast aside the bar and gave a hand.

"Come on," he said hopefully. "One, two—three! Heave!"

"Heave!" muttered Bob.

But although the post, which had formed a corner of the arbor, gave from side to side, it refused to leave its nest. Panting, the boys drew off and observed it glumly.

"We 'll have to dig some more," said Bob.

"Wait a minute. Let me get a purchase on it with the bar."

Laurie seized that implement again and drove it into the softened earth beside the post. As the first drive did n't send it far enough, he pulled it out and put all his strength into the next effort. This time he succeeded beyond all expectations. The bar slipped through his fingers and disappeared from sight!

"Well!" he gasped. "What do you know—"

"Where—where did it go to?" cried Bob, dumfounded.

"It went—it went to China, I guess! It just slipped right through my hands, and kept on slipping!" Laurie knelt and dug at the hole with his fingers.

"Find it?" asked Bob. "Try the shovel."

"No, I can't feel it. Hand it here."

Laurie took the shovel and dug frantically. Then Bob dug. The result was that they enlarged and deepened the hole around the post, but the crowbar failed to materialize.

"I suppose," said Laurie, finally, dropping the shovel and tilting back his cap, "what happened was that I struck a sort of hole, and the bar went right down in. Maybe it was a rat-hole, Bob."

"I guess so. Anyway, it 's gone, and we 'll have to get a new one."

"Oh, I guess we 'll find it when we get the post out. Let 's try the old thing."

They did, and, after a moment of indecision, it came out most obligingly. But there was still no crowbar to be seen. Laurie shook his head, mystified. "That 's the funniest thing I ever saw," he declared.

"It surely is! Look here; maybe there 's an old well there."

"Then why did n't the post go down into it?"

"Because it 's covered over with stones. The bar happened to slip into a—a crevice."

Laurie nodded dubiously. "That might be it," he agreed. "Or perhaps we 've discovered a subterranean cavern!"

"Caverns always are subterranean, are n't they?"

"No; sometimes they 're in the side of a hill."

"Then they 're caves."

"A cave and a cavern are the same thing, you smart Aleck."

"All right; but even if a cavern is in a hill, it 's underground, and subterranean means under—"

"Help! You win, Bob! Come on and get hold of this log and let 's get it out of here." And as they staggered with it across the garden to add it to the pile of posts and lumber already there, he continued: "There is one thing certain, Bob, and that 's that you won't get me to play tennis on your court. I 'd be afraid of sinking into the ground some fine day!"

"Maybe you 'd find the crowbar then," said Bob. "Heave!"



Laurie "heaved," patted the brown loam from his hands, and surveyed the pile. "There 's a lot of good stuff there," he pondered. "Some of it 's sort of rotten, but there 's enough to build something."

"What do you want to build?"

"I don't know. We could build a sort of covered seat, like the one in Polly's yard,

"No; we 'll have to have another crow-bar."

Laurie looked relieved. "Well, let 's go over and see whether the Widow 's got any of those little cakes with the chocolate on top," he suggested. "Hard work always makes a fellow hungry."

There was a rousing football meeting in the auditorium that evening, with speeches and music, songs and cheers; and the enthusiasm spilled over to the yard afterward and threatened to become unruly, until Dan Whipple mounted the steps of School Hall and spoke with all the authority of eighteen years and the senior class presidency. Whereupon some one suggested a cheer for the doctor, and the joyous crowd thronged to the west end of the building and gave nine long "Hillman's," with a "Doctor Hillman" on the end. And then suddenly the lights flashed on on the porch, and there was the doctor and Miss Tabitha, the former looking very much as if he had awakened very recently from a nap—which was, in fact, the case. But he was smiling as he stepped to the doorway and near-sightedly surveyed the



"THE BAR SLIPPED THROUGH HIS FINGERS AND DISAPPEARED FROM SIGHT!"

where folks could rest and look on. Take about six of these posts and some of the strips, and some boards for the seat—"

"Who 'd dig the post-holes?" inquired Bob, coldly.

"Oh, we could get a couple of the others to help. Honest, Bob, it would be a lot of fun. Maybe we could n't do it before spring, though."

"I might leave the stuff here," said Bob. "Thomas could sort of pile it a little neater, you know. I love to carpenter. Sometime we 'll draw a plan of it, Nod."

"Right-o! How about those other posts? No use bothering with 'em to-day, is there?"

throng of laughing, talking boys.

"This—er—testimonial would appear to demand some sort of a response," he announced, as the applause that had greeted his appearance died away. "But I find myself singularly devoid of words, boys. Perhaps some of you recall the story of the visitor in Sunday-school who was unexpectedly called on by the superintendent to address the children. He hemmed and hawed and said, finally, that it gave him much pleasure to see so many smiling, happy faces. And he hoped they were all good little boys and girls and knew their lessons. And then his eloquence failed him, and after an unhappy

interim he asked, 'And now, children, what shall I say?' And a little girl in the front row lisped, 'Pleathe, Mither, thay "Amen" and thit down!'

"Perhaps I 'd better say 'Amen' and sit down, too," he went on, when the laughter had ceased; "but before I do I 'd like to assure you that I am 'rooting' just as hard as any of you for a victory the day after to-morrow. My duties will not allow me to see the team in action as much as I 'd like to, but I am kept well informed of its progress. I have my scouts at work constantly. Mr. Pennington reports to me on the work of the linemen; Mr. Barrett advises me each day as to the backs; Mr. Wells is my authority on—er—stratagem."

This amused his hearers intensely, since none of the three instructors mentioned had ever been known to attend a game or watch a practice.

"And," continued the principal, when he could, "I follow the newspaper reports of our enemy's progress. Of course, I don't believe all I read. If I did, I 'd be certain that only overwhelming disaster awaited us on Saturday. But there is one thing that troubles me. I read recently that the Farview center is a very large youth, weighing, if I am not mistaken, some one hundred and seventy pounds. While mere weight and brawn are not everything, I yet tremble to consider what may happen to the slight, atomic youth who will oppose him. Young gentlemen, I shudder when I dwell on that unequal meeting, that impending battle of David and Goliath!"

When the new burst of laughter had subsided, the doctor continued more soberly: "I wish the team all success, a notable victory. Or, if the gods of battle will it otherwise, I wish it the manly grace to accept defeat smilingly and undismayed. I am certain of one thing, boys, which is that whether fortune favors the Dark Blue or the Maroon-and-White, the contest will be hard fought and clean, and bring honor alike to the victor and vanquished. You have my heartiest good wishes. And—" the doctor took the hand of Miss Tabitha, who had been standing a few steps behind him,— "and the heartiest good wishes of another, who, while not a close follower of your sports, has a warm spot in her heart for each and every one of you, and who is as convinced as I am of the invincibility of the Dark Blue!"

"Three cheers for Tab—for Miss Hillman!" cried a voice; and, at first a trifle

ragged with laughter, the cheers rang forth heartily. Then came another cheer for the doctor and a rousing one for "Hillman's! *Hillman's!* HILLMAN'S!!!" And the little throng dispersed to the dormitories.

Friday saw but a light practice for the first team and a final appearance of the scrubs, who, cheered by the students, went through a few minutes of snappy signal work, and the waving sweaters and blankets dashed off to the field-house, their period of servitude at an end. For the first team there was a long blackboard drill in the gymnasium after supper, and Ned, who, somewhat to his surprise and very much to his gratification, had been retained on the squad, returned to Number 16 at nine o'clock in a rather bemused condition of mind. Kewpie, who accompanied him, tried to cheer him up.

"It 'll be all right to-morrow, Nid," he declared. "I know how you feel. Fact is, I would n't know one signal from another if I got it this minute, and as for those sequences—" Words failed him. "But when you get on the field to-morrow it 'll all come back to you. It—it 's sort of psychological—a trick of memory and all that."

"I don't see why he needs to worry, anyhow," observed Laurie, cruelly. "He won't get a show in to-morrow's game."

Ned looked hopeful for a moment, then relapsed into dejection as Kewpie answered: "I 'd like to bet you he will, Nod. I 'd like to bet you that he 'll play a full period. You just watch Farview lay for Pope! Boy, they 're going to make hard weather for that lad! They were after him last year, but they could n't get him and he played right through. But I 'd like to bet you that to-morrow they 'll have him out before the last quarter."

"What do you mean?" asked Laurie, in surprise. "They don't play that sort of a game, do they?"

"What sort of a game?" responded Kewpie. "They play hard, that 's the way they play! And every time they tackle Pope, they 'll tackle him so he 'll know it. And every time he hits the line, there 'll be one of those red-legs waiting for him. Oh, they don't play dirty, if you mean that; but they don't let any chances slip, believe me!"

"It sounds sort of off-color to me, though," Laurie objected. "How are you going to put a fellow out of the game if you don't slug or do something like that?"

Kewpie smiled knowingly. "My son," he said, "if I start after you and run you around the dormitory about twenty times—"



Ned, in spite of his down-heartedness, snickered at the picture evolved, and Kewpie grinned.

"Well, suppose some one else did, then. Anyhow, after he 'd done it about a couple of dozen times, you 'd be all in, would n't you? He would n't have to kick you or knock you down or anything, would he? Well, that 's what I mean. That 's the way they 'll go after Pope. They 'll tire him out. You understand. And every time they tackle him, they 'll tackle him good and hard. Well, suppose Pope does go out, and there 's a chance for a field-goal, as there 's likely to be. Who will Pinky put in? Why, Nid, of course! Who else is there? Brattle can't kick one goal in six. No more can Deering. What do you think Mulford 's been nursing Nid all the season for?"

"Next year?" said Laurie, questioningly.

"Sure—and this year, too. You watch and see. I 'd like to bet you that Nid 'll have a goal to kick to-morrow—yes, and that he 'll kick it, too!"

"Don't!" groaned Ned. "I never could do it!"

"Well," laughed Laurie, "I don't bet for money, Kewpie, but I tell you what I 'll do. If Ned kicks a goal to-morrow, I 'll take you over to the Widow's and I 'll buy you all the cream-puffs you can eat at one sitting!"

"It 's a go!" cried Kewpie. "And if he does n't, I 'll do it to you!"

"Of course," explained Laurie, in recognition of his brother's look of pained inquiry, "I am not making the offer because I think Ned can't do it or because I don't want him to play. You bet I do! It 's because I do want him to, Kewpie. You see, I usually lose bets!"

"All right, you crazy galoot. I 've got to beat it. Pinky made us swear by the Great Horn Spoon to be in bed by ten. Good night. Don't let the signal stuff worry you,

Nid. It 'll come out all right to-morrow. You understand. Night!"

When the door had closed, Laurie laughed and turned to Ned. "He 's a good old scout, is n't he? I say, what 's the matter with you, Ned? You look like the end of a hard winter! Cheer up!"

But Ned shook his head, although he tried to smile unconcernedly. "It 'll happen just the way he told, Laurie," he said, sadly. "I just know it will! They 'll get Pope out of the way, and there 'll be a field-goal wanted, just as there was Wednesday, and Mulford will send me in!"

"Well, what of it? You 'd like that, would n't you?"

"I—I 'm scared!"

"Oh, piffle, Neddie! You 've got nerves, that 's all. The night before the battle, you know, and all that! In the morning you 'll be as right as rain. Get your clothes off and tumble in. Want me to read a story to you? There 's a corker in the 'Post' this week."

"No, thanks; I guess not. I 'd better go to sleep."

But although Ned, stifling a desire to sit up and read the corking story himself, put the light out at ten minutes before ten, he lay awake until after midnight and suffered as blue a case of funk as any boy ever did. And when, at length, sleep came, it was filled with visions in which he stood in the center of a vast area, the object of countless eyes, and tried over and over, and never with success, to kick a perfectly gigantic leather ball over a cross-bar that was higher than the Masonic Temple at home!

The truth is that Ned was overtrained and stale. And the further truth is that when he awoke to as sweet a November morning as ever peered down from a cloudless sky through golden sunlight, he felt, as he phrased it to himself, like a sock that had just come through the wringer!

(To be continued)

## U-N-I-T-E-D S-T-A-T-E-S

U stands for Usefulness, Uprightness, too;  
 N stands for Neatness in all that we do;  
 I for the Interest we feel in our work;  
 T for the Tasks that we never will shirk;  
 E for the Exercise that we must take;  
 D for our Duties we will not forsake;

S for Sincerity, Steadiness, too;  
 T for our Teachers, with so much to do;  
 A for Ambition, Achievement, as well;  
 T for the Truth that we all strive to tell;  
 E for the Excellence that we may gain;  
 S the Success that we hope to attain!

*Kitty Parsons.*

# THE WASHINGTON ELM

By WILLIAM H. BERTENSHAW



THE WASHINGTON ELM AT CAMBRIDGE

hundred feet in height, and ninety feet in the spread of its branches.

Soon most of its forest friends were cleared away, and a thriving town, which was to be the home of Harvard University, had grown up around it.

About this time things began to happen, and the Thirteen Colonies decided to throw off the yoke of the mother country. War was declared, and George Washington was called up from the south to take command of the army.

At nine o'clock in the morning of July 3, 1775, a noted delegation met under the shade of the big elm's branches. Here the big men of the colonies offered Washington the command of the Continental Army, and he, stepping forward and drawing his sword, with a few appropriate words, accepted.

When the war was over, it was natural that this old tree should be regarded with patriotic pride, and, as the years rolled by, that it should be visited by an increasing number of patriotic visitors eager to see this historic landmark, one of the few living things that link the small colonies with the big, prosperous nation of to-day. It saw Cambridge grow from a little pioneer town to a highly developed and very modern community; it watched Harvard change from a little college into a university of world-wide fame.

Now it stands in a fenced-in plot, with traffic passing on both sides. It is a shadow

MORE than two hundred years ago, in the wilds of what is now Cambridge, Massachusetts, a small American elm-tree sprang into being in much the same way as all elm-trees do. This elm became a useful shade-tree and reached a size not common to its species — measuring eighteen feet in circumference, one

of its former self in strength and size, for old age and numerous attacks of leopard-moths and elm-leaf beetles have reduced it to scarcely more than the skeleton of a tree.

In August, 1872, a seventeen-inch branch was blown down, part of it being used to make a pulpit in the chapel of a near-by church.

A tablet marks the site of this historic



THE ABOVE TABLET BEARS THE FOLLOWING INSCRIPTION: "UNDER THIS TREE WASHINGTON FIRST TOOK COMMAND OF THE AMERICAN ARMY, JULY 3, 1775"

spot, and, at the present rate of decay, in ten years there will be little else left to mark the place where, one hundred and forty-seven years ago, the young nation pinned all its faith on a man who was to be known later as the Father of his Country.



# THE DESTROYERS

By ARCHIBALD DOUGLAS TURNBULL

OF all the many branches of our navy, none is more interesting than the destroyer service. For that reason, many officers and men are constantly applying for duty with these active, adventurous little craft. Indeed, I think the personnel of our navy, given the choice, would man all the destroyers before joining any of the other types. This feeling has grown with the development of the destroyers themselves.

A good many years ago, the United States, like other countries, had a considerable squadron of "torpedo-boats." These were small craft of about two or three hundred tons, built, as their name implies, to carry torpedoes, and, since they mounted no guns of any size, virtually for no other purpose. With a speed of over twenty knots, the little fellows were intended to sneak up, chiefly at night, on the enemy's slower-moving battle-ships, fire a torpedo or two, and then sneak away again. They ran because they were not built to stand up and fight, but to be a sort of sea-going hornet with a very sharp sting.

At first, they seemed to be highly effective. Long, slim, fast, painted dark-green or black, they were not easy to see, even in the daytime; and once seen, they were very hard to hit. Boats like the *Gwin* and the *Talbot*, which we had in commission in Cuban waters during the Spanish War, always gave a good account of themselves. But because of their small size, they were rather uncomfortable to live in, particularly in bad weather. And for the same reason they were useless for cruising, for any length of time, without returning to the base for fuel and provisions.

In the effort to keep these annoying little torpedo-boats away from the big fleets, the navies of the world soon began to build a new type. This was a craft much like the small boat in appearance, but larger in every way, able to make higher speed, and armed with guns of a three-inch caliber. For want of a better name, the new type was called a "torpedo-boat destroyer." Originally, it was not intended that such a boat should carry many torpedoes. Instead, the destroyers were to patrol a fleet, steaming in wide columns on each side, if the big ships were under way, or circling, if the fleet was

at anchor. Then, if the enemy's torpedo-boats attacked, the destroyers were to sink or drive them away before they could come near enough to launch a torpedo.

Of course, no sooner were the bigger boats designed than it became perfectly plain that they could replace the little ones. There was no reason why they should not carry torpedoes in addition to guns. Since they were larger, more space could be used for fuel, so they could stay at sea much longer. In other words, they could do everything that the little fellows could—and do it much better. Consequently, the torpedo-boat, as such, has practically disappeared. We no longer build them, and very few are built by other navies. However, the name of "destroyer" has clung to the later type, which has grown from seven hundred and fifty to fifteen hundred tons, carrying four-inch or five-inch guns as well as plenty of torpedoes. Developments in the torpedo itself, as well as in the use of oil as fuel, instead of coal, have made the destroyer a very important factor in a modern navy. Oil is not only much easier than coal to handle,—provided the tanks are tight,—but also, ton for ton, it gives much more heat. This means that the latest boats are able to cross the Atlantic at moderate speed without stopping to re-fuel, to make, at full power, more than thirty-five knots, and, with the heavier guns, to put up quite a fight.

Like most ships, the destroyer is divided into water-tight compartments. This is in order that any compartment which has been pierced by a shell, or has a hole for any other reason, can be shut off while the other compartments keep the ship afloat. Not a square inch goes to waste, but there is plenty of room for five or six officers and about a hundred men. In one way or another, between plenty of hard work and plenty of play, the whole ship's company manages to get along very well indeed—always provided that the cook is a good one!

Even in peace-time, the life aboard a destroyer is far more eventful than on a larger ship. Getting about so much more quickly, as they do, the boats do more cruising, see more queer little out-of-the-way places than the fleet could ever do. With

their light draft, fourteen or fifteen feet, they can go into shallow waters. For example, when President Roosevelt, in 1907, sent our fleet around the world, some of the destroyers went too. They were the only ships that could get up the river to Buenos Aires, the interesting capital of the Argentine Republic. The battle-ships had to be content with steaming along a few miles from the coast, exchanging salutes with an Argentine Squadron that came out to meet them.

On the Atlantic Coast, the destroyers base at Newport during the summer and at Pensacola or Charleston in winter. From these bases, they carry out gun-practice, torpedo-practice, and all sorts of trials at high speeds. Often they make cruises up to Halifax, through the Gulf of Mexico, or down to the Caribbean Sea. As they handle very easily, they can manœuvre very close together, sometimes only fifty yards apart. But this means that the man at the wheel and the man at the throttle must be prompt in carrying out orders; frequently nothing but the quickest work possible prevents a collision.

After the destroyers have finished a good deal of this sort of training, they go as squadrons to join the battle-ships for fleet drills and manœuvres. Among other things, this means night attacks, when all the ships steam without lights. The attacking destroyers have to get within a certain distance of the big ships without being seen. Of course, the fleet is assigned other destroyers to guard it, so the game is hide-and-peek on a large scale, with regular rules, umpires,

and score-keepers. Running without lights means that every man must be on his toes all the time and every eye peeled for the "enemy." On the big ships, there is keen rivalry to be the first to make out the des-



"FULL SPEED AHEAD!"

troys in the darkness; while on the little fellows, it is touch-and-go all the time. When a lucky boat does slip in close, she fires a red star, like a Roman candle, to show the battle-ship that, according to the rules, she has been sunk.

Daytime manœuvres are not quite so exciting, but there is plenty to see and do. In these attacks, the destroyers often fire torpedoes at the battle-ships. These "exercise" torpedoes are fitted with special heads,



which collapse when the torpedo hits. Of course, they are not loaded with guncotton, the explosive charge usually used. But for all that, it seems very real. The torpedo has to be made ready for the run as if for a war shot; all the adjustments of pressure,—the torpedo engine is driven by compressed air,—the setting for depth of run, the adjustment of the steering-gear, and a dozen other steps must be made before the torpedo can be fired. Then, when it is rushing through the water as fast as forty knots an hour, it makes a long white wake, and from the target—that is, the battle-ship—it looks extremely businesslike. The score at the end of the attack is sent out by signal from the flagship. It is watched for just as eagerly as baseball scores. For everything counts in making up the final relative standing of the destroyers for the year. The winning boat is allowed to fly, until the next year, a special pennant, which represents the "Battle-efficiency Trophy," the biggest prize a ship can win. Of course, the winner is pointed out everywhere and it is a fine thing to be one of her crew.

Speaking of baseball, sports of all kinds are followed in the destroyers, as indeed they are throughout the navy. Baseball teams, football teams, rifle teams, track teams, boxers, wrestlers, and, of course, boats' crews for pulling and sailing races, are practising every available minute. Inter-ship games of every description, including golf and tennis matches between officers' messes, are played every summer in the north, and then in winter, usually in Guantánamo, Cuba, where the navy has its largest southern base. After the destroyers have settled their own championships between themselves, they often make up a division or a squadron team, to play the battle-ship winners. This is done because a battle-ship has, as material for the teams, ten times as many men. The greatest excitement comes with the playing of the important games; thousands of men, from the commander-in-chief down, turn out to root for their favorites. Quite often, the destroyers "bring home the bacon," which stirs up an awful row among the battle-ships, who pretend to look down upon the little fellows. Altogether, sport forms a very important part of navy training. It keeps all hands in good shape physically, it makes the competition in drills and gunnery all the keener, and, best of all, it helps along the good spirit of the service.

This good spirit is the most vital as well as the finest thing for any navy. It is the thing that makes navy men, no matter how much they may be rivals among themselves, stick together like burs. It teaches officers and men to like and respect each other; in the end, it is the thing that wins battles. For no matter how intelligent or how well drilled the men of the ship or the fleet may be, they are sure to fail unless they have that within them that makes them stand by the other fellow, and pull not against him, but with him. We have that spirit very highly developed in our destroyers; we always have had it. But when the great Admiral Sims was in command of all the destroyers, about ten years ago, he was so ready to talk to anybody, he made every man so friendly with the next one and so enthusiastic for the flotilla as a whole, he worked so constantly for spirit, that the effect of what he did still remains. His name is one to conjure with, wherever you find a destroyer. At heart, the admiral is a destroyer man—so is every one else that ever served with the flotilla. Those who have left it, for one reason or another, to serve in other ships, still hold on to all their love for the little fellows. But they are splendid for the other types. The hard work and the quick thinking that they learned stays with them always. Destroyer men do well at anything in the big ships, and the officers, because they have had so much experience as youngsters, are the best of ship handlers. There is really no training to equal it.

The value of destroyers, many of which had been built by England, France, and the United States, was very clearly proved in the Great War. In fact, from the naval standpoint, particularly America's, this was a "destroyer war." Of course, this does not mean that the destroyers were the only vessels of importance. On the contrary, every one knows that if it had not been for the British Grand Fleet, with its dreadnaughts, battle-cruisers, and other large ships, Germany would certainly have won. The "command of the seas" was not maintained merely by destroyers. But it was they that carried on by far the greater part of the active offensive; it was they that destroyed the Hun submarines, or "kept 'em down" so they were useless. Millions of miles of sea were covered by the destroyers of all the Allies, in patrolling coasts, escorting convoys, or hunting submarines. They had exactly the qualities needed—speed that



U. S. Navy Official Photograph

Wide World Photos

"UNITED STATES DESTROYERS LAYING A SMOKE-SCREEN TO CONCEAL THEIR MOVEMENTS IN A TORPEDO ATTACK ON SOME OF THE DREADNAUGHTS OF THE ATLANTIC FLEET IN THE WAR GAMES OFF GUANTÁNAMO, CUBA"

enabled them to circle the fleets of merchant ships bound for Europe with soldiers, ammunition, or stores, or to overtake and ram a submarine; guns powerful enough to deliver a shell that would sink a submarine; and fuel capacity to keep at sea for a considerable time. It is because the winning of the war depended upon preventing the submarines from cutting off the steady stream of supplies to England and France, and because the destroyers did just that, that we are justified in speaking of it as a "destroyer war."

Unfortunately, when the United States entered the war, our navy did not have enough destroyers. Also, most unfortunately, the secretary of the navy did not recognize that the biggest help we could give would be to send every available boat at once to Europe, where the real danger lay. A few were sent, however, the first division of five being commanded by Captain Taussig. When, at the end of the long trip across the Atlantic, that division reached Queenstown, the British admiral commanding was more

than glad to see them. He knew how badly our ships were needed, both to relieve, for overhaul, the British destroyers that had been hard at it for nearly three years and to afford that much more protection to shipping. The admiral asked when our boats would be ready for duty, how much time they would need for repairs after the crossing. Captain Taussig replied: "We are ready now, sir!" and set his small force to work at once!

Later, we began to build about two hundred destroyers, a few of which were completed in time to help. As soon as one was made available, Admiral Sims sent back a commanding officer and part of a crew, to form a nucleus of experienced men for the new boat, men who "knew the game," and the boat went right over to join the forces in Europe. Only a few of our boats were lucky enough to have an engagement with the enemy, but they did splendid work in helping to save the merchant shipping of the world. So much did they help that if we had made, in 1917, the effort we were making a year later, the war would have been won



much sooner than it was. For not until the "unrestricted submarine campaign" was a proved failure did Germany make her last drives on land. However, every boat that did get to Europe was sure of having the exciting sort of life that she and her crew were looking for so anxiously. Often this excitement came not through the enemy, but through other emergency, the sort of emergency for which the destroyer must always be ready. For instance, there was the case of the *Shaw*.

The *Shaw*, whose captain was Commander Glassford, was doing the same work as all the rest, escorting transports loaded with soldiers through the waters where the enemy submarines were thick. One day, Commander Glassford was escorting the huge *Aquitania*, with thousands and thousands of American troops on board. Besides the *Shaw*, the *Duncan* and one or two other destroyers formed the escort, but Commander Glassford led the way. It was the escort-commander's duty to keep his ship zigzagging ahead of the transport, dashing from one side to the other on the lookout for periscopes. As the *Aquitania* was making about twenty-two knots, at the time, the *Shaw* had to run at something like twenty-seven, to cover so much more sea and still hold her position.

It was early morning when the *Shaw*, on one leg of the zigzag, was headed across the course of the *Aquitania*. This was part of the regular plan, so many minutes on one course, so many minutes on the next. But when it came time to turn away, when the order was given to put the helm over, the steering-wheel jammed. The *Shaw* could not turn away. At the speed the two ships were making, collision was inevitable. The captain had about ten seconds to make up his mind. He saw that he would hit the *Aquitania* just about amidships; he knew that his sharp bow would cut a fearful hole; and he knew what the appalling result would be. He thought of all those troops, many still asleep, who would probably be thrown into the sea; he looked at his own crew of about a hundred, weighing their lives and his own against those of the soldiers. But in far less time than it has taken to write of it, Captain Glassford's decision was made. He sprang for the engine-room signal and rang for "Full speed astern!"

He had smart men on his ship; he got what he had to have. Under terrific strain and vibration, the engines, reversing, took hold of the *Shaw*. They changed her course, as the captain knew they would, just enough to fling her—right across the bow of the *Aquitania*!

In another second, the monster had crashed into the *Shaw*, and just at the bridge where the captain stood, cut her in two! Two of the *Shaw*'s officers and ten or a dozen men were instantly killed. The bow of the *Shaw* drifted away, while what was left of her, bumping along the steel side of the big steamer, struck sparks that immediately set fire to the oil-tanks. The masts were shaken out of her, seams everywhere were opened up, the ship's colors went over the side with the wreckage. But—the captain and the crew were still on deck. As they dropped astern of the *Aquitania*, they set to work fighting the fire. Because the firemen at the boilers had stuck to their posts, there was steam to be had; and steam will smother an oil fire where water only spreads it. Having got the better of the fire, the crew turned to the main engines. Although all the machinery was badly strained, first one engine, then the other, was persuaded to spin. Then one man dove overboard, seized the colors, clambered over the side, and lashed the flag to the stump of the mast. When the *Duncan*, standing by, would have taken off all hands, Captain Glassford shouted: "No! We're all right. Go ahead with the *Aquitania*!" As he was still escort-commander, his orders had to be obeyed. He sent the transport safely on her way. Then he and his crew took the *Shaw*, stern-first, but under her own steam, fifty miles to the nearest British harbor!

Hundreds of men on the *Aquitania* never knew there had been a collision; the big ship was unhurt, and there was no panic. All of which was because the *Shaw* had executed what was one of the smartest pieces of seamanship of the whole war. Unless Captain Glassford had made the right decision at once, unless he and his crew had carried out that decision instantly, there would have been a terrible disaster with the loss of no one knows how many lives. Yet the *Shaw*'s whole ship's company thought of what they had done, and spoke of it, as "all in the day's work!"

# THE HILL OF ADVENTURE

By ADAIR ALDON

## SYNOPSIS OF PREVIOUS INSTALMENTS

IN the small town of Ely, in the Rocky Mountains, Beatrice Deems, her sister Nancy, and their Aunt Anna settle down for the summer. The town is full of foreign laborers who, led by a Finnish agitator, Thorvik, begin rioting when the irrigation company that employed them ceases work for lack of funds. Finding Ely untenable, Beatrice moves the household to a cabin on the mountain-side. They are helped by Thorvik's sister Christina, whose son Olaf is a sailor at home on leave. The cabin's nearest neighbors are John Herrick, the head of the irrigation company, and his adopted daughter Hester. A would-be reporter and amateur detective, Dabney Mills, is seeking to solve the mystery of why the irrigation company is without funds when it had seemed so prosperous. Dr. Minturn is a friend who lives on the other side of the mountain. The girls' invalid aunt finally breaks her long reticence and tells them the reason of their coming to Ely—the hope that she may there find some trace of her brother Jack who, thinking that his family suspected him of dishonesty, broke with them and vanished ten years before. The girls believe that John Herrick is this brother, but do not tell their aunt, fearing to raise false hopes. Dabney Mills confides to Beatrice that he believes the irrigation company's funds have been made way with by John Herrick. He does not shake her confidence in John Herrick, however, but she goes over the mountain to seek advice from Dr. Minturn. As she and Nancy are returning together, they find John Herrick on the trail, badly hurt by a fall, and watch by him all night through a snow-storm on the summit of the mountain. They are rescued by Dr. Minturn. As John Herrick recovers, reconciliation and a new understanding with his family follows and all seems going well, when Beatrice, in a moment of hasty anger, under Dabney Mills' cross-questioning, reveals the fact of the relationship. The reporter, immediately sensing a mystery and the fact of a cloud over John Herrick's past, rushes away to communicate his suspicions to the mob of hostile men in the valley.

## CHAPTER XVII

### DAN O'LEARY'S MESSAGE

HAVING failed to call back Dabney Mills, Beatrice went slowly into the house. She was thinking of that boulder that had rolled from under her horse's feet on the climb up Dead Man's Mile. She remembered vividly how it had bounded down the slope, disappearing in the wood—to do what damage, she could not tell. In much the same way her thoughtless speech had escaped her lips, betraying a secret that, now quite beyond her reach, was doing harm at which she could only guess.

They all went to bed early that night, for Aunt Anna, who had just come home from her brother's, was tired as well as happy, and Nancy had been so busy that she could not keep her eyes open until an early bedtime. But Beatrice, restless, troubled, and wakeful, could not compose her mind for any thought of sleep and lay staring into the dark, wondering and dreading what was to happen next. So intent was she upon her disquieting thoughts, that she did not notice, at first, a light tap, tap that came repeatedly against her window casement.

"It is raining," she thought at last, when the sound had attracted her attention. "I must get up to see if it is coming in."

Yet she postponed, as people always do, the effort of rising to investigate, and would have paid no further attention had not the

sound continued insistently. When she sat up at last, she saw to her surprise that the stars were shining through her window and that it was not raindrops, but a handful of gravel, that pattered on the sill. She jumped up, drew her big coat about her, for the night air was cold, and leaned out. A shadowy figure, unrecognizable in the starlight, stood below her.

"Miss Deems," said a voice, a rich Irish voice that, after a moment of doubt, she realized belonged to Dan O'Leary, the man who used to care for Buck, "Miss Deems, there 's the mischief to pay down in the town to-night, and this Dabney Mills, here, vows that it was your doing."

She then discerned a second figure skulking among the shadows, a very crestfallen Dabney Mills, brought hither, evidently, by no desire of his own.

"He came to the meeting," went on Dan, "and gave us a long tale of how John Herrick's past had come out at last, how he had got into disgrace back East and came here to lose himself and take another name. And from that, the fellow argues that it was John Herrick took the money we have all been looking for this long time. I thought it only best to come straight to you for the truth, since he was quoting you."

Poor Beatrice's teeth chattered with cold and misery as she leaned against the window-frame and tried, below her breath, to explain just how matters stood. Had Aunt Anna



been wakeful, she would have been reading in the room below and would have overheard; but fortunately she was slumbering soundly on the sleeping-porch at the other side of the house.

"Some of what he said is half true," Beatrice began, "and some of it is absolutely false."

Dan O'Leary listened to the end of her story without comment.

"I was hoping you could say there was n't a word of truth in it," he said finally. "The men below are wild with anger and are coming up the hill to tax John Herrick with what they think he has done. They were walking, and we had horses; but they 'll not be so long behind us. Well, I 'll go back and stop them if I can."

"Could n't you—could n't you go up the hill and warn him?" Beatrice asked desperately.

"No, they 'd call me traitor if I did. I 'm a good friend to John Herrick, but after all, I 'm one with those below and pledged to help them. We 'll be going back now. I 'll do the best I can. Here," to Dabney, "get on your horse and come along. It 's just such know-nothings as you that let loose most of the mischief in the world."

After they had gone, Beatrice still stood clinging to the window-frame, stunned and bewildered. This then, was the result of her angry words—this was the mischief that she had set on foot! What could she do to make amends? She did not have to think long, but she turned from the window with a sigh that was nearer to a groan. She must lay the matter before John Herrick—tell him the whole truth of what she had said and what had been the result. He could never forgive her, of that she felt sure. She had put an end, all in a minute, to that new-found trust and friendliness that had been so hardly won. Yet it was the only thing to do.

Buck, who had been brought home a week before, pricked his intelligent ears at the sound of his mistress's footsteps. For once, he submitted without protest, to being saddled, as though he were too full of curiosity concerning this strange night adventure, to make any delay.

Down the path to the gate they made their way, then up the trail as fast as Buck could be urged, with Beatrice's head turned over her shoulder to peer down at the town below. One building was brilliantly lighted—the hall where the men's meetings were held. There were lights in many of the houses, too, although it was so nearly midnight. Carried

by the chill wind that blew up from the valley, came a far-off sound of shouting voices from the throng of angry men who were marching up the trail.

John Herrick's house was alight also, for he was a person of late hours. She could see, as she came up the steps, that he was sitting by the big table in the living-room, and that Hester was nodding over a book in the chair beside him. Since he was up and about again, she seemed unwilling to leave him for a moment.

Beatrice knocked quickly, but could not wait for an answer and burst in upon them, beginning to pour out her story before she was half-way across the room.

Hester, starting up, listened in frank bewilderment, but the expression on John Herrick's face was quite different. The tale was none too plain, but he seemed to guess, long before Beatrice had finished, what it was she was trying to say.

"Tell me," he said at last, when she paused, "tell me one thing." Her heart sank, for his eyes were hard and his tone was harsh and dry. "Why did you come here? Was it to warn me, so that I could go away?"

"Oh, no, no!" she gasped, still breathless and incoherent. "I only felt that you ought to know what harm I had done. I wanted you to be ready to explain to the men when they came that it was I who had—"

"Do you mean," he interrupted her, leaning forward in his chair, his eyes fixed on her with a strange, intense eagerness, "do you mean that you do not believe as they do? That you don't suspect me of stealing that money?"

The blank astonishment on Beatrice's face was answer enough, without her eager words: "Of course I did n't think so! It would n't be possible!"

He leaned back and put his hand over his face, as though suddenly weary.

"God bless you, Beatrice!" he said. "I will remember that always, that you believed in me."

He rose slowly, limped across the room, and opened the door of a safe, let into the wall between two bookcases. He brought out two steel boxes and set them on the table.

"Now go and open the doors," he said, "so that when our friends arrive, they can come in at once."

While he unlocked the boxes, Hester went to do as he had directed; but Beatrice, wondering and fascinated, could not leave his side.



"BEATRICE FOUND HERSELF TELLING WHAT HAD HAPPENED" (SEE PAGE 965)



The first lid that he lifted showed bundles of bank-notes, and the second, shining piles of heavy gold-pieces.

"Yes, this is the money they have been asking for," he said.

## CHAPTER XVIII

### A SONG FROM OVER THE SEA

FOR a little time there was no sound in the big room as Beatrice stood gazing in open-mouthed astonishment at the piles of gold and silver heaped upon the table, Hester, meanwhile, standing at the outer door to listen. The night sounds of the mountain came in—the wind among the trees, the squeaking of a bat, the far-off yelp of a coyote. Presently however, these faint noises were drowned in another, distant, but growing nearer and louder—the angry voices of excited men and the tramp of feet upon the road.

Beatrice went to the door beside Hester and, for what seemed a very long time, stood waiting without a word being spoken by any one of the three, so intently were they all listening. Much as Beatrice desired that John Herrick explain the presence of that money upon the table, she dreaded his speaking, for she wished to lose no sound of the tumult that was coming ever nearer up the hill.

The mob of men was in sight now, climbing the last rise of the trail. They were singing some wild foreign song; it might have been Russian, Polish, Hungarian, she knew not which. The words conveyed no meaning to her, but the loud harsh cadences seemed to cry out a message of their own, a song of blind tyranny and passionate rebellion, of cracking whips and pistol-shots, of villages burning amid shouts and weeping and the cries of children. She shivered with terror as the loud voices came close.

"If only they were Americans!" she whispered to Hester. How could any one control such a mob that scarcely understood a common tongue?

"There is no knowing what they may do," Hester whispered in answer, "but if any one is able to quiet them, Roddy can."

The men came tramping up to the foot of the veranda steps and stopped, a dense, huddled throng with a tossing lantern carried here and there that showed the dark faces and the shining, excited eyes. A few figures stood out against the foreign background, a handful of American and Irish laborers, Dan

O'Leary, head and shoulders taller than the others, Dabney Mills hovering on the outskirts of the group, talking incessantly and unheeded.

Thorvik stood on the lowest step, his back to them, bareheaded and pouring out a stream of words. Two or three men stepped up to him and began an earnest discussion, which waxed hotter and hotter each moment. The crowd quieted and all stood waiting. Dabney Mills joined the speakers, shaking his head and protesting vehemently. Beatrice, leaning forward, caught enough of the broken English to understand the meaning of their hesitation. They were arguing as to which should go in first. Inside, a great sum of money was spread out upon the table, with no one to guard it but an injured man and two girls, yet these disturbers of the night's peace were quarreling as to who should enter first!

It was Dan O'Leary who finally pushed through the crowd and strode up the steps. The girls turned to watch him cross the hall and stop before the table where John Herrick sat unmoving.

"Well, boss," the Irishman said simply, "how about it?"

John Herrick's thin face relaxed into a smile.

"Why don't your friends come in?" he asked.

"They 're a bit shy," Dan admitted. "I hear them talking it over how you are the best marksman in Broken Bow County."

John Herrick's smile grew broader and he got to his feet.

"Then I suppose I must go out to them," he said, "if they won't come in."

He limped slowly across the hall and out upon the steps. A great roar went up from the men as he appeared, then silence fell.

"The money of which there has been so much talk is in there on my table. Is there any man who cares to come in to count it?"

There was no answer, nor did any one come forward. Thorvik, hurrying from one to another, whispering, pointing, urging, seemed to have no influence at all. Dabney Mills, shrill and abusive, shouted something from the back of the crowd, but no one moved. Dan O'Leary burst into a great roar of laughter and slapped his knee.

"You should have heard them tell, on the way up the mountain, what they were going to do!" he declared to Beatrice, at whose side he was standing. "Thorvik and Mills—why

they were breathing fire, and now look at them." He stepped forward and stood by John Herrick. "Boys," he said, "I 'm through. I came up here with you to ask the boss a question, to find out if he had got away with any of the irrigation company's funds. Well, I don't care any more to ask it. I know he 's all right."

Beatrice turned at a sound behind her and saw Olaf, followed by old Julia and Tim, come pushing through the door. The man and woman were both deaf, and the boy slept in one of the outbuildings, so that they had only now been awakened by the noise. Olaf's eye was fixed unwaveringly upon Thorvik, and that worthy, suddenly becoming conscious of the fact, began to sidle away into the background and disappeared behind the bulk of a gigantic Slovak. Beatrice laid a restraining hand on Olaf's arm, for John Herrick was speaking again.

"You shall have an explanation," he began, "though I have been waiting for you to understand of yourselves. While you were talking up your strike, or, rather, while your leader was talking and you were listening, the irrigation company was coming to the end of its funds. Why? Because, after your valuable Thorvik came to this place, construction dragged, no man did a full day's work any more, time and material and money were being wasted until the whole enterprise was at the edge of disaster. Was it easy to raise more capital, do you think, when the whole camp was seething with discontent and everybody knew that a strike was coming? No, the men who had put money into the project, far from being willing to subscribe more, were wishing they could withdraw. So it came about that we moved first, and shut down the work the very night that you were ready to declare a strike. It was a good thing for both sides; we all needed a little time to think things over."

He paused, as though for comment from his audience; but no one spoke and he went on again.

"While you have been—resting, I have been working, and I have managed to arrange for enough capital to carry on the work to the end, on one condition: when things are not to your liking, you are to use the good American way of talking matters over and settling them peaceably, not the method you have brought with you from over the sea—rioting and burning and stirring up hatred between one man and another. On that basis we can go on. In a crisis like this, it is always easiest

to blame one man, and you have chosen to blame me. What you have been saying about me, I neither know nor care; but if you had used your own wits,—instead of Thorvik's,—you would have seen how things really stood. And I will tell you this. Through all this time of waiting, I have kept in my safe a sufficient sum in cash for immediate use, so that when the time came to begin again, we could go forward without a day's, without an hour's, delay. It is there, as I said, ready for you to earn it. And now, have you had enough of Thorvik and his talk of revolutions? Do you want to go back to work?"

"We want to go back!" shouted a voice from the crowd.

It was an American voice, but its refrain was taken up in a dozen foreign tongues. Yes, it was plain that they were weary of their leader and that they wished to work again.

"Then go home and get some sleep and we will start work in the morning," John Herrick said. "The money will be there to pay your next week's wages, and there will be enough for one thing besides—it will buy your precious Thorvik a ticket back to his own country. And we will all see that he makes use of it."

"But—see here," Dabney Mills' querulous voice rose above the murmur of approval, "I 've been telling them—"

Then it was that Beatrice had her greatest surprise. She found herself suddenly standing on the step beside John Herrick, telling what had happened; making plain to that strange, listening group the source of Dabney's story. With her hand holding to her uncle's, she spoke out bravely and told the whole truth—just what had really occurred and just how the reporter had spied and listened and questioned and put together his so-called facts. She even found herself, at the end, telling of Dabney's inglorious encounter with the bear.

Although the men did not understand much English, her speech was so direct that they could easily comprehend the greater part of it. When she came to the affair with the bear, such a shout of laughter went up that it drowned what little more she might have wished to say. The men slapped each other on the shoulder, told the story all over again to one another in their own tongues, rocked and chuckled and burst forth again and again in uproarious mirth. It seemed to touch the sense of humor of every one of them that the strutting, vainglorious young reporter should have been the hero of such an ignominious



adventure. When the gale of merriment had somewhat laughed itself out, Dan O'Leary's voice could be heard above the others.

"We don't need any more proof that they belong to each other," he said. "The pluck of the little one and the pluck of the big one, they sure come from the same stock. And now let 's be getting back and be ready for work in the morning. We need n't spend time waiting for Sherlock Holmes—he has gone on ahead, and another of our friends with him."

Under cover of the noisy laughter, two people had quietly slipped away. A pair of shadows flitting down the trail, a slim one and a sturdy one, was the last that Beatrice saw of Dabney Mills and Thorvik.

The crowd dispersed and went trudging down the mountain-side, as John Herrick had advised, to sleep in preparation for the work next day. Their voices and laughter could be heard from afar as they wound down the path, a cheery, comforting sound after the angry shouts and that wild, terrible song that had heralded their coming. Beatrice, standing to look after them, felt a sudden wave of friendliness and good will for the whole company that, a short time before, she had regarded with such terror and repulsion.

She went in at last to talk the whole matter over with John Herrick and Hester and Olaf and Dan O'Leary, who had stayed behind. They heard the tale, not only of the irrigation project, but of all that had led up to it. The story was of a man beginning with nothing and in ten years gathering the fortune that he was now putting into the watering of the valley. It was wealth reaped from the fertile, untried resources and the open-handed opportunities of a new country. The valley was in the hands of prospectors and homesteaders when he came; he had seen the mines opened, the farms plowed from virgin soil, the wilderness changed to a settled country. After the pioneers and the farmers, had come the crowd of foreign laborers, to build the railroads, to pick the fruit, to rear the houses and dig the irrigation ditches.

"They are a blight on the country," said Olaf; but John Herrick shook his head.

"We need them" he insisted; "we have to help them and teach them, and their children will be good Americans. There are a few like Thorvik, who will cause trouble to the end of the chapter; but we can make something of the rest of them."

It was the mountain above them that alone

had not changed, he went on to tell them, although it was the mountain that had made the valley what it was. It had given its treasures of gold and silver, the timber and pasturage of its lower slopes, its roaring streams watered the fields, and the valley was fertile with soil washed from its rocky shoulders.

"A good part of the mountain belongs to me," John Herrick said, "and a bit of it to Beatrice. I can go higher and higher, blasting its rocks, cutting its trees; but at a certain point I have to stop. There is no man yet who has conquered the wind and clouds and cold of the summit, and Gray Cloud Mountain is still master of us all."

When at last he ceased talking, it was only because Hester had dropped asleep in her chair and the gray dawn was showing behind the windows. Beatrice was still listening eagerly, so was Olaf, who heaved a long sigh as the story came to an end.

"I wish I were going to do things like that," he said wistfully.

"You are," returned John Herrick; "and so is Beatrice and Hester, too. There are just such adventures ahead of all of you. In times like these, every person who is growing up now will find his share of strange, new things to do. Now you must take Beatrice home, Olaf. You children should not have let me talk the whole night away."

Dan O'Leary, who had said very little, got up and held out his hand to Olaf as he said good-by.

"We 'll be glad to see you down in the town," he declared. "We 've got over some things we used to think about you, and we 've learned a great deal this night."

They rode slowly down the hill, and Beatrice and Olaf turned in at her gate, still discussing the night's adventure.

"He is a real man, John Herrick is," was Olaf's final verdict as they reached the steps of the cabin. "You can't beat him for fairness or for pluck. And you know, the first time I saw you, I thought you were like him. I believe I had begun to understand that you belonged to each other long before any one told me so."

She lingered on the steps, watching him lead Buck away to his stable and then mount his own horse.

"I ride like a sailor," he admitted, as he climbed into the saddle, "and—I did n't tell you—I am off to sea again next week. My mother does n't like my going, but I can't stop ashore more than this long. Now that

all this trouble is cleared up, I will go down to stay with her until I leave. And you will go to see her won't you, after I am gone?"

"Yes," promised Beatrice; "but we are going ourselves before very long. I can't believe the summer has really passed. Hester is coming with us to go to the school where Nancy and I go, and John Herrick—can I ever call him anything else I wonder?—is coming too. But in a year we shall all be back again."

Olaf rode away, leaving Beatrice sitting on the steps, still wide awake and reluctant to go in. The cabin was very still—evidently no one had awakened to miss her in the hours that she had been gone. She sat very quietly, watching the sky grow red between the black columns of the pine-trees, listening to the soft thunder of the waterfall and the growing chorus of the birds as they awoke with the awakening dawn.

An approaching footstep surprised her. Someone had come very softly up the needle-strewn pathway while she sat there dreaming. It was a figure that she did not recognize at once, a person with outlandish clothes, a yellow face, and two baskets slung upon a bamboo pole.

After a moment of inspection she exclaimed, "Joe Ling!"

The Chinaman nodded. "I leave your house because trouble was coming," he explained. "Trouble over now," he waved his hand toward the village; "I come back."

By some secret sense through which Chinamen seem to know everything, he had got

news of the outbreak in the town almost before it had occurred, and had departed; but now, having divined just as quickly that the difficulty was over, he had returned. There could be no more convincing proof that peace and quiet were really restored in Ely.

Beatrice thought for a minute, inclined at first to send him away. She was beginning to know more of the strange ways of Chinamen, however. "And besides," she reflected, "it will not do Nancy and me any harm to have a vacation from our work for these last days that we are here."

She nodded to Joe Ling, and he made his way around the corner of the house, to be heard, presently, in the kitchen making preparations for breakfast as easily as though he had been in residence a twelvemonth.

She would soon be going back to all the old interests, she thought, still without moving. Lessons, dances, club-meetings—how far away that had all seemed to be. Everything would look different to her now; she would not be discontented again nor wonder if the future was going to be dull, since she had once realized how much life can hold.

Leaning back against the door-post, she sat contentedly staring out across the hill. In the room upstairs, Nancy was stirring, for Beatrice heard the window close. Soon she would have to go in to relate all that had happened in the night; but just for a minute more she would watch the glowing sky, the moving tree-tops and the peak of Gray Cloud Mountain showing clear and sharp in the first light of dawn.

THE END

## WONDER THOUGHTS

I CAN NOT tell you how they come,  
Nor yet the reason why,  
But somehow they come oftenest  
When no one else is by.

Sweet music always brings me them,  
Or bells across the snow;  
In winter-time they march to me  
From out the fire's glow.

Through meadows when the day is new  
They steal into my mind;  
And often in a flower's cup  
A lovely one I'll find.

At night when I am in my bed  
And quiet shadows creep,  
They come and whisper round my door  
And crowd into my sleep.

At times they are so very sweet  
And solemnful that I  
In just the gladdest sort of way  
Would almost like to cry.

At other times they make me laugh—  
They come with such surprise.  
I'm sure, if you were near enough,  
You'd read them in my eyes.

*Faith Van Valkenburgh Vilas.*



# Good News



by Arthur  
Guiterman

AN eminent cat has discovered, they say,  
A river of cream in the Great Milky Way.  
While a mouse, who has seventeen college degrees,  
Declares that the moon is undoubtedly cheese!

## THE GRATEFUL BUNNIES



Winander Otis Victor Lear  
Was good to Bunnies, far and near;  
He never called them "little thieves,"  
But gave them cool, fresh cabbage-leaves.

So when his birthday feast was held,  
The grateful Bunnies came, and spelled  
Their friend's initials with their ears,  
And gave him three wild Bunny cheers!

Arthur Guiterman.



# THE LAST LAUGH

By HARRY STARKEY ALDRICH

Formerly flight-commander with the 1st Aéro Squadron, A. E. F.

"STUBBY" ROBINSON, pilot, swung his heavy flying-suit over his shoulders and turned toward the steep path that led up the hill to the broad, flat aërodrome of the "Grizzly Bear" Squadron.

"Letter here for you, Robinson," called a young chap, from the doorway of the squadron mess-hut.

"It 's from good old Bill," Stubby thought joyfully, and he tore the envelop open and read:

Dear Stubby:

I can't believe it 's only four weeks since you left the flying-school here—seems more like four months. Most of the fellows in our class are still here, kicking because they 're not being sent up to the front, and I guess I do my share, too. Raines, Hemming, and Kenny Bandel were sent yesterday to some aéro depot to be ferry pilots. That 's the lingo for pilots who fly replacement planes to squadrons needing them at the front, is n't it? I've been trying to be assigned to your squadron, but it looks as though a fellow had to have an A-1 flying record. I guess that spoils most of my chances, if it 's true. Glad to hear that you think observation work is just as exciting and more interesting than duty with a pursuit squadron. Write again soon, and don't fall asleep when you 're over the lines.

'S always, your pal,

BILL.

Stubby slipped the letter into his pocket and slowly climbed the path to the aërodrome. He was proud, certainly, of belonging to the famous Grizzly Bear Squadron, but there lacked one thing to make it perfect in his estimation, and that one thing was his good friend Bill, more formally known as Lieutenant William Anthony.

Ten minutes climbing brought him breathless to the top of the hill. Behind him at the foot of the path lay the squadron living-quarters which he had just left. They nestled among a thick growth of firs and pines, where they were well hidden from the keen eyes of any hostile scout-plane. Before him stretched the broad flat hilltop which formed the flying-field.

Nearly a mile distant, on the opposite edge of the aërodrome, stood the row of huge camouflaged hangars, capable of holding as many as eight or ten observation-planes. About them stood the usual smaller tents, and to one side, far away from the rest,

stood the first-aid tent, its Red Cross flag hanging limp above it in the hot July sun.

Stubby made his way across the field to Hangar Two. There, on its shady side, sat several observers and pilots waiting for the time at which they were scheduled to depart upon their various missions.

"Your trip over has been postponed for half an hour, Stubby," said a red-headed, good-natured flier in the middle of the group.

"In that case," decided Stubby, "I might as well wait here for a while. Anything in particular doing this morning?"

"Everybody reports that the lines are rather quiet," replied the red-headed pilot.

"You forget Dick Wetherill's wild story, Red," reminded one of the others with a chuckle.

"Well, hurry up and tell it," urged Stubby.

"He came back from a mission with a dozen bullet-holes in his plane," said Red, "and declared that the machine that attacked him bore the American insignia on its wings."

"I suppose that 's possible," said Stubby, judicially. "It might have been some 'green bird' who mistook Dick's ship for one of the enemy's. It 's hard to tell, sometimes, when the sun is in your eyes."

"Sure. That 's probably how it really was," agreed Red; "but stubborn old Dick insists that it was an *enemy* pilot who flew the plane."

"Rubbish!" exclaimed Stubby, with an incredulous smile. "That 's too much to swallow. Did Dick show his own colors plainly?"

"Said he stood his ship nearly up on end, so the other fellow could see his insignia, but the firing did n't stop. Then he said he opened fire himself and the plane dived away toward the lines."

"The observer who went up with Dick," offered another of the group, "was busy in his cockpit at the time, adjusting his magazine of plates, and when he stood up to see what all the firing was about, the other plane had flown off. He said it looked like one of our scout-planes, but he could n't see its colors."

"It must have been an American pilot, all right," grinned Stubby. "Some one who has just been sent up to the front."



"Sure it was!" asserted one of the others, grinning in return. "But Dick stuck to his crazy story like a mule. We tried to argue with him for a while, but he went off madder than a hornet."

"Well, all I have to say," said Stubby, in some admiration, "is that Dick Wetherill has a heap of grit to stick to it. It takes more than mere stubbornness to face the kidding of this outfit. He is sure to be ragged unmercifully."

The conversation halted as a two-seater was noticed approaching the aërodrome in a long, slow glide.

"Who is it?" asked Red, squinting hard at the plane.

"It 's not one of our fellows," said Stubby, who had the keen eyes of a kingfisher. "It 's a new plane. Must be a ferry pilot bringing one of our ships ordered from the air depot."

This prediction proved true. As the plane reached the hangar the group of fliers crowded about. A strange flier at an aërodrome on the lines was an event of some moment. News, unobtainable quickly in any other way, was then picked up. The pilot, having turned the plane over to the mechanics, pulled off his confining head-gear better to answer the bombardment of questions hurled at him.

"Whoopee!" exclaimed Stubby, seizing him by the hand and pumping it vigorously. "If it is n't old Kenny Bandel. Just got a letter from Bill this morning saying that you had become a blooming ferry pilot."

"'Blooming' is right," growled Bandel, after he had satisfied his enthusiasm at meeting his former flying-school friend. "I was on the point of being ordered to this very squadron when your C.O. found out about that bad smash-up I had at the training-field and refused to O.K. me. Then I was ordered to the depot to ferry."

"Major Cowes is a peach of a squadron commander," said Stubby, frowning a little, "but I do know that he uses a fine-tooth comb on the records of any pilot wanting to join this squadron. Among ourselves, we call him 'The Judge.' How was Bill when you saw him last?"

"Same old Bill, but crazy to get up here on the front. He 's trying hard to join the Grizzlies, I think."

"Hey, Robinson," called some one from the door of the operations hangar, "your mission 's due to start in a few minutes."

"See you at mess this noon, Kenny," said

Stubby, hastily, and sped over to Hangar One, where four mechanics were wheeling forth his two-seater. On each side of its silky fuselage was painted the squadron insignia, a rearing, pawing grizzly bear and, some distance from that, the enormous white numeral "15."

"I think you 'll find her all right, sir," said "Mac," the chief of the mechanics.

"Good," said Stubby. He critically tested the tension of his right-wing flying-wire. "She 's the best-rigged ship in the outfit, Mac."

"Yes, sir," Mac replied, nearly bursting with pride.

When Stubby had completed his careful inspection of "15," Taylor, the observer who was to accompany him, arrived. He climbed up into the rear cockpit, arranged his map-case, and stowed away the several magazines of machine-gun bullets.

"It 's a short mission, Stubby," he announced. "We have just to range the eight-inch guns of Battery M62 on that ammunition-dump that the enemy recently made at the edge of Delville Woods. Here 's a photograph of it that Red took two days ago." He handed the print to his partner.

It showed the soft-looking tops of the trees of Delville Woods. On the northern edge of the woods ran a narrow band of white. Stubby knew that it was the main highway which the enemy used for transporting men and ammunition to the lines. Along it on each side were many shell-holes, indicated by grayish-white spots, showing that the American artillery already had been giving it unwelcome attention. At one edge of the woods, near the road, Stubby made out the munition-dump, a weird, light-gray blue.

"Red took a line of pictures along that side of Delville again yesterday, and the prints don't show even the sign of a shadow," continued Taylor. "If the first string of pictures had been taken a day later, the chances are that we never should have discovered the dump, they have concealed it so well."

"Neat work," commented Stubby. He returned the photograph to the observer and climbed into his flying-suit.

"Wonder if Johnny Clearman is ready to start," he said. "He, with Beaner as observer, is going up in Number Ten, as our protection-ship."

"I forgot to tell you that Johnny went out on a mission early this morning and has n't

come back yet. The flight-commander has assigned Number Eight to protect us."

"I hope nothing has happened to him!" exclaimed Stubby, fervently.

"If it were anybody else than Johnny," said Taylor, "I 'd be worried; but he 's such a rattlepate that nothing serious will ever happen to him."

"Number Eight is Dick Wetherill's ship, is n't it," said Stubby, suddenly. He smiled, thinking of the story Red had told him.

"Yes, it is," grinned Taylor. He, too, had heard the tale.

Stubby looked at the line of planes in front of Hangar Three and saw Number Eight set out in readiness. Wetherill, in flying togs, sauntered over.

"We 're all set, Stubby," he announced.

"We 'll get off right away, then," replied Stubby, adding, unable to resist a little ragging on his own account, "and Dick—"

Wetherill turned. He looked as though he knew what Stubby was going to say.

"If we should happen to fly in your direction, don't get excited and try to shoot us down."

"If my machine-gun belt had n't jammed this morning," Dick averred stoutly, "you fellows would be congratulating me right now on my first enemy plane, instead of—"

"You mean your first downed American plane," Stubby corrected, with a wink at Taylor. "If you don't watch out, the enemy will be decorating you for heroism."

"Say, look here," began Wetherill, in excusable exasperation. Then he stopped short, and when he continued, his voice was even. "All right, old top. But remember about the man who laughs last." With great dignity he returned to Number Eight.

Two minutes later, Number Fifteen took the air after a short run across the field into the wind. Wetherill followed close behind. As he circled about the hill, Stubby carefully tested his controls and twice pressed the button that fired his guns to see that they were ready for instant use. Meanwhile, Taylor ran out his aerial wire and sent his radio-call to the squadron station below.

"All set?" inquired Stubby, using the head-phone with which the plane was equipped.

"Yes," Taylor replied. "Step on her."

Stubby "stepped." With a brisk wind blowing from behind them at the two-thousand-foot level, "15" tore through the air at such a speed that she quickly over-

hauled her protecting ship, which, not having to adjust its radio, had flown on ahead.

At Jouarre, they passed a flight of scout-planes winging its way home after a patrol over some section of the front. A little farther on, Stubby saw Wetherill signal to him by rocking his ship from side to side. After a moment, it glided earthward for a few hundred feet and then turned slowly back toward the aërodrome.

"Dick 's having motor trouble," he thought, "but we might as well keep on. We 'll just have to keep a closer look-out for the enemy."

He communicated this to Taylor, and, in the small mirror that gave him a clear view of the rear of the plane, he saw his companion nod assent.

Ahead, the balloon line and a few occasional puffs of smoke on the ground from bursting shells indicated that they were nearing the front lines.

Several miles to the right, there was a sudden brilliant flash.

"One of our balloons shot down, I think," came Taylor's voice through the telephone.

Stubby nodded.

Another thirty seconds passed, and "15" was circling above the main radio-station for that section. Near by, some distance below the plane, was a great gray observation-balloon, tugging northward at the end of its long steel cable. In the frail wicker basket beneath it, Stubby could see the figure of the lone observer keenly scanning the enemy's side of the lines through his powerful field-glasses.

After a brief exchange of radio signals with the station below, "15" headed for Delville Woods. They crossed the lines and inspected the target without drawing the fire of the anti-aircraft guns. There was no visible trace of an ammunition-dump or anything else near the spot below that corresponded with Stubby's map, nor was there a sign of any movement in or near the woods. However, the two fliers knew that the dump was there, just as they knew that the eyes of hundreds of the concealed enemy were closely watching their plane.

Stubby turned and headed back into his own lines. Taylor sent down a call to the battery. Straightway, the battery's panels, acknowledging the signal, appeared in a small clearing south of the apple-orchard that hid the guns.

As he turned north toward the enemy again, Stubby noticed a second bright flash,



announcing the destruction of another balloon some miles to the east. There followed a red-yellow flash, streaking earthward, leaving behind it a widening path of pitch-black smoke. He looked in vain for the plane of the destroying enemy.

Back and forth they flew, between the target and the battery. At each turn above the latter, Taylor flashed down the signal to fire; and at each turn over the target, he sent back the correction of deflection and range. The first rounds, the battery firing with but two guns, fell wide of the mark.

Several more turns were made. All four guns of the battery were firing now, and the upheavals of brown earth crept closer and closer to the target. Stubby hoped, indeed he felt certain, that the next salvo would strike it. He intensely disliked the sound of bursting "archie" shells, which were now coming too close and frequent for reasonable comfort, as the enemy gunners, in a panic, realized that the munition-dump was the prey marked by the plane circling above.

The plane headed north, almost wearily. Then, without warning, a few seconds after Taylor's signal, "Fire," a great volume of dense black smoke shot high into the air above the edge of Delville Woods. It carried with it tons of brown earth, portions of trees and planks, and fragments of red-hot steel and shell.

Automatically, Stubby changed the direction of his ship. He had no wish to encounter the air ahead, torn and rent, gaping with swirling, invisible air-pockets. Safely out of the danger zone, he turned to look again at the target when—

"Crack! Crack-crack-crack!" The language of the machine-gun!

Before the nose of Stubby's plane appeared thin white lines of smoke. He knew that they were the paths of tracer-bullets whizzing by; and he knew, that for each tracer-bullet whose path he could see, there were two or three armor-piercing bullets whose paths were invisible.

He threw the control-stick over and whirled about, his thumb on the firing-buttons of his guns. Immediately the firing ceased and an American scout-plane raced past "15's" propeller. There was no mistaking either the make of the plane or its colors. Stubby saw its pilot tip his ship slightly from side to side and raise his gloved hand in evident apology.

"Clumsy fool!" growled Stubby, half relieved, half disappointed. "That must be

the 'green bird' that fired on Dick. He ought to be reported for—"

It suddenly occurred to him that he could not report the blundering flier even had he wanted to do so. *The fuselage of the plane bore neither squadron insignia nor numeral.* Before the thought was complete, he pulled his plane up on her sturdy left wing and charged after the scout, which was some distance away speeding eastward.

"Where in Sam Hill—" he heard Taylor begin.

"Get your guns ready," he shouted back into his 'phone. There would be time for explanations later.

If the pilot ahead knew he was being followed, he gave no sign of it, but flew straight on for several minutes. Stubby saw him swerve suddenly and dive squarely at the American balloon above the chief radio-station, firing a fusillade of streaking bullets into it at short range. "15" was turned also, but it was not yet within firing range of the scout-plane, which now zoomed up over the great bag and prepared to dive again.

The observer leaped from the wicker basket beneath the balloon and dropped like a stone for two hundred feet. Then the air caught the parachute strapped to his shoulders and filled it instantly. His headlong flight was abruptly checked and he floated swiftly, but safely, to the ground. From the guns grouped about the balloon-winch rose a hail of shrapnel and "flaming onions" as the gunners saw that they had been tricked, but stopped a moment later when Stubby's guns opened fire on the masquerading flier.

Desperately its pilot tried to recover from his second dive. As a last resource, he turned his plane on its side and whipped about, sending a sharp burst of fire in Stubby's direction. The latter's guns had passed out of position, so he banked to give a clear field of fire to Taylor's guns, which cracked steadily. Stubby, looking over his shoulder, saw the scout waver, recover, waver, spin for half a revolution, and glide steeply to earth.

An hour later, Stubby, alone in "15," was flying swiftly back to the aërodrome. But the news he bore had flown on ahead even more swiftly. When he landed, an excited group of fliers surrounded his plane.

"Great work, old timer!" roared Red, hopping upon a wheel of the plane and thumping Stubby on the back. "Balloon



"THE OBSERVER LEAPED, AND DROPPED LIKE A STONE FOR TWO HUNDRED FEET"



Station L22 telephoned in, about thirty minutes ago, crediting you and Norm with downing an enemy ship disguised as one of ours."

"It was n't disguised,—it *was* one of our planes," said Stubby. He was a bit surprised that his news was already known. "We think it's one of those scout-planes of the Wolverine Squadron that the enemy captured intact about two weeks ago. The Wolverine insignia and numeral on it had been painted out."

"We heard that this same fellow got two of our balloons this morning, and had nearly succeeded in getting a third when you got him," said another of his friends. "This means another big feather in the cap of the Grizzlies."

Stubby climbed contentedly to the ground. It was no small thing to have the Grizzly Bear Squadron actually proud of one.

"Where's Norm Taylor?" asked some one.

"Up at the balloon station. He's making a careful inspection of the plane, so that he can turn in a report."

"Dick Wetherill was right, after all," remarked Red, somewhat conscience-stricken, as he accompanied Stubby down the hill to the mess-hut. "He'll surely crow over us now."

"Yes, he will," agreed Stubby, with a chuckle. Then he remembered when he had last seen Wetherill. "Did he get back to the field all right?"

"No. He was forced to land in a rough meadow and bent his axle. He'll be back this afternoon, I suppose. We heard from Johnny Clearman, too. He got lost in some fool way and landed, out of gas, about forty miles from Courcelles. The Judge has ordered that he be detached from the squadron and sent back to the air-depot as soon as he returns."

"That's a shame!" exclaimed Stubby. "The Judge is too all-fired strict."

"Well, I dare you to run over and tell him so," said Red, with a wry smile.

At three o'clock Stubby left to fly Taylor back to the aërodrome. Flying rather low and not far from his destination, he noticed an American scout-plane of the same make as that encountered earlier in the day. It was flying at an even lower altitude, headed toward the lines. Ordinarily, Stubby would not have given more than passing notice to a plane crossing the lines within such easy

range of the enemy's guns; but the morning's events were too fresh in his mind for him not to feel suspicious at once.

Acting upon the impulse, he dived. His suspicions were confirmed by the absence of both squadron insignia and numerals from the fuselage of the plane, while on its wings were painted the American colors.

During this examination of the unsuspecting plane, Stubby had lost so much altitude that he found himself in a poor position to attack. He turned to climb. He was not a second too soon, for, diving squarely at him from another direction, came an enemy fighting-plane. He veered, escaping the shower of bullets from the plane as it flashed past. He executed a "half-barrel," which instantly reversed his direction and brought him on the tail of the fighter. This advantage he followed up with a heavy burst of fire, which sent the hostile plane into a violent tail-spin. It spun dizzily down, and Stubby, waiting a breathless second for it to crash, saw it abruptly flatten out just above the trees and fly north. Its pilot had used a common trick to escape from a precarious situation.

But during that second, Stubby had been guilty of a piece of folly that was inexcusable in a pilot of even his short experience over the lines—he forgot about the other plane. When he did remember, he saw, too late, that his manœuver had brought him directly in front of the guns of the scout.

Instinctively, he braced himself for the hail of fire. None issued from the threatening guns. Instead, the pilot swung about and headed in the opposite direction, in apparent confusion.

"His guns are jammed," breathed Stubby, and he gave chase, firing a few rounds, which fell short.

The pilot changed direction several times, evidently thoroughly confused or in a panic or both. When Stubby succeeded finally in coming within firing distance of it, it was miles from the enemy's lines. Below, Stubby's eyes caught sight of a huge winding stream which looked familiar. They followed its course and saw the Grizzly Bear's aërodrome two miles away. Stubby was filled with delight at this. As the plane ahead turned again, he tacked, accordingly, to cut it off and motioned its pilot to the aërodrome that was then directly below. The pilot replied by again swerving away, and Stubby sent a sharp burst of fire across his upper wings. Evidently thinking it best to

give up, the pilot spiraled down, closely followed by "15."

As they neared the ground, Stubby noticed groups gathering on the field in front of the hangars. He chuckled as he imagined their excitement over the sight of one American plane deliberately firing upon another.

The pilot of the captured ship, being unaccustomed to the field, or excusably nervous, misjudged his distance somewhat and landed at the northern edge, nearly a mile from the hangars. Stubby landed twenty feet away. Jumping from his cockpit, pistol in hand, he ordered the pilot to climb down and throw up his hands.

The latter climbed down, sulkily, Stubby thought, but he did not throw up his hands.

"Kindly quit shaking that forty-five at me and tell me what it 's all about," he growled, impatiently tugging at the helmet, which came off with a jerk.

Stubby stepped back with a gasp.

"Bill Anthony!" he exclaimed, when he had caught his breath again. "What on earth, man—" He stopped, incoherent.

"Stubby Robinson, are you the crazy loon who has been scaring me white-headed the last fifteen minutes?"

"What were you doing up there at the front?" asked Stubby, bewildered. "Have you joined a squadron?"

"Why, I 'm ferrying. At least, I 'm trying to. I 'm taking that scout-plane to the Wolverine Squadron to replace one they lost a couple o' weeks ago," answered Bill, trying to understand it all, himself.

"Ferrying?" repeated his friend, gazing at the scout-plane.

For the first time, Stubby saw that its guns were wrapped with the dark, oily cloths in which new guns come from the supply-depot far behind the front. He saw for the first time that it was a brand-new ship, a fact that entirely explained the absence of numeral and squadron insignia.

"Yes," answered Bill, "ferrying. I lost my maps soon after starting out from the depot, and as I had studied the route pretty well, I did n't go back to get new ones. I did n't know I was lost and thought I was miles south of the front, when I heard the firing and saw you send that fighter down. I was sore at you when you began to chase me and fire in my direction. I thought you were just trying to have a little fun with me. I understand now that, if you had n't happened along, I should have been captured."

He paused for his friend to make some

answer, but Stubby was silent, realizing with something akin to horror the perilous situation in which Bill had placed himself.

"Would n't it have been just my luck to be captured like that?" Bill paused a moment with an expectant eye on Stubby. "And just when I had finally succeeded in getting orders to join the Grizzlies."

His expectations were fulfilled.

"Whoopee!" shouted Stubby, in huge delight. "That 's the great—" He stopped short and stared blankly at Bill. Then he turned and looked back. Approaching on the run was a scattered group of fliers and mechanics. He turned to Bill.

"Quick, Bill, I want you to do me a big favor. Will you do it?"

"Why, yes," began Bill, grateful enough to do anything.

"Then give me your word of honor not to say anything about your getting lost and flying over the lines," said Stubby, tensely.

"Why I can't do *that*, Stubby. How could you explain—"

"It 's not very much to ask," Stubby's tone was cutting; "quick—will you?"

"Yes," agreed Bill, hesitatingly, but impelled by his friend's insistent manner. "But how will you explain your—"

"Leave that to me. The main thing is this. Our C.O. would never accept you into the squadron if he learned about this. Only this morning he ordered a flier named Clearman back to the depot for getting lost, with more excuse than you had." Assuming a sheepish grin, he faced about toward his breathless squadron mates.

A story travels fast at the front. The squadron rocked in hilarious mirth. It was the great joke of the season—Stubby Robinson's mistaking a poor ferry pilot (and his own chum, at that) for the enemy in disguise, trying to shoot him down, and finally forcing him down in triumph on his own field.

"Stubby," warned Dick Wetherill, gravely, from his end of the long mess-table that night, "if you don't watch out, the enemy will be decorating you for heroism."

A roar of delighted laughter met this sally. Stubby flushed as he recognized his own words.

He glanced down the table at Bill who had that afternoon been formally accepted as a pilot in the Grizzly Bear Squadron. Then he looked back at his tormentor with an inward sigh of contentment.

"All right, Dick," he said, "it 's yours—that last laugh."



# ALMOST A MUFF

(A WINDY DAY IN CENTER FIELD)

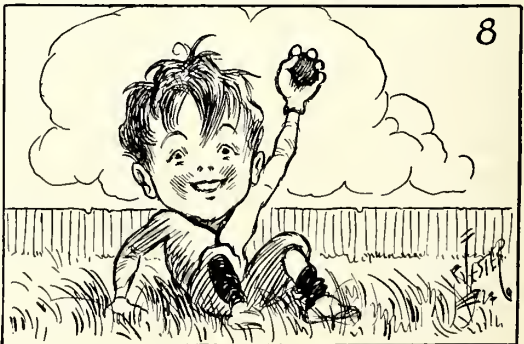
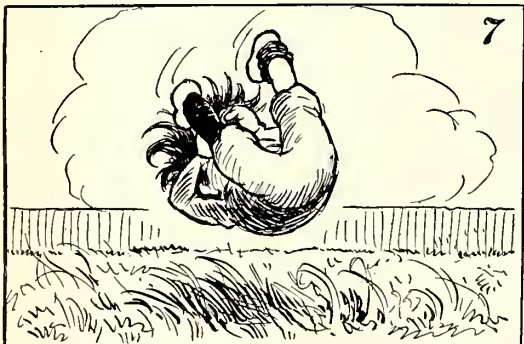
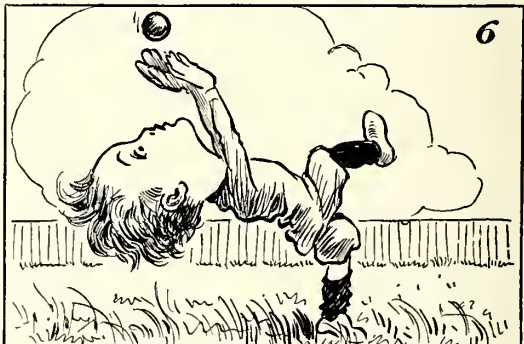
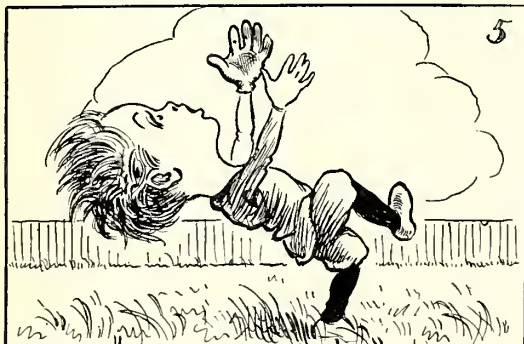
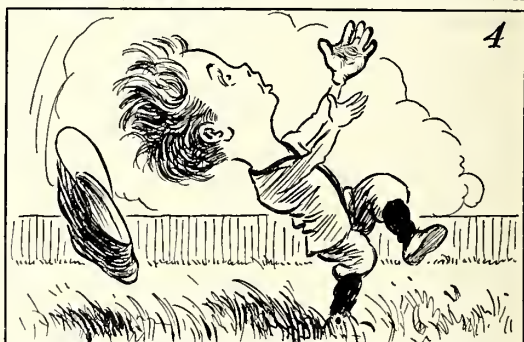
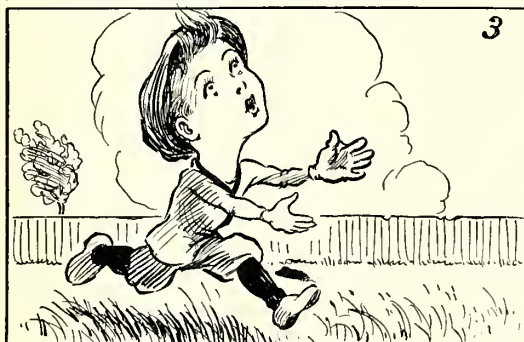

# THE INCA EMERALD

By SAMUEL SCOVILLE, JR.

*Author of "Boy Scouts in the Wilderness," "The Blue Pearl," etc.*

## SYNOPSIS OF PREVIOUS INSTALMENTS

PROFESSOR AMANDUS DITSON, the great scientist, has discovered the location of Eldorado, where for hundreds of years the Incas of Peru threw the best emeralds of their kingdom into the lake as an offering. The professor's ambition in life is to secure a living specimen of the bushmaster, the largest and most venomous of South American serpents. He calls on Big Jim Donegan, the lumber-king and gem-collector, and offers to lead a party to the lake if Jim will finance the trip, and to allow the lumber-king to have the emeralds, provided Ditson can keep the bushmaster. Jim promptly agrees to this, and Jud, the old trapper, Will, and Joe, the Indian boy, who together found the Blue Pearl for Jim Donegan, agree to go on the trip. Jud and Professor Ditson bicker as to who shall lead the expedition. A whip-scorpion decides the discussion in favor of the professor. They hear and see strange and beautiful birds in the forest, and Jud gets tangled up in a multitude of thorny vines and shrubs and has an adventure with a trail-haunting black-snake. The party enjoys wild milk and honey, and Will studies the tropical butterflies. At night, in a deserted house, vampire-bats break through the screens and he is badly frightened and bitten. The party travel by steamer to Manoa's, the hottest city in the world. There they change to an Indian boat and travel down to Black River, which they enter by night, contrary to the Indian superstitions. Joe has a terrible experience with an anaconda, and Will is nearly swallowed by a giant catfish. They pass Treasure Rock and hear its story. Attempting to run the rapids of Black River, they are shipwrecked, and lose their equipment. They have an adventure by night with a jaguar, which Professor Ditson frightens away. Pinto, the Indian, makes for himself a blow-gun and the fatal urari poison; and under his direction, the party builds a new boat and starts on down the river. Pinto, Will, and Jud are treed by peccaries, Will is driven down to the ground by fire-ants, and his life saved by a sudden attack on the herd by a black jaguar. They come to the Falls of Urari, where the Slave Trail begins, which runs clear across the basin of the Amazon to the lost Lake of Eldorado.

## CHAPTER VII

### THE YELLOW SNAKE

OVER a vast horseshoe of towering crags, with a drumming roar, the dark, resistless river rushed in a mass of snowy foam and broken rainbows down into the whirling caldron below.

"The Falls of Utiarity," whispered Pinto, as he guided the boat into a little bend by the bank just above where the terrible downward glide of the river began. Making fast to a tree on shore, the whole party stared across at the most beautiful waterfall on earth, as if they could never see enough of its beauty. Something seemed to give way in Will's brain, and for a long minute he felt as if he were entering a new and strange world. Dim, unearthly images seemed to float before him. He thought of the great white throne in Revelation—the mystic emerald circled by a rainbow and the pavement of a single sapphire-stone. Before him was the beautiful water sinking into the abyss, yet flowing on forever, while a great rainbow trembled, faded, then came again through the mist and spray like a beautiful spirit walking the waters. With the terror, the rush, and the roar of the crashing waters, was a beauty not of earth that took away all fear, until he seemed to

be gazing into the seventh heaven and seeing that which was unlawful for mortal man to look upon.

Only a moment, and once more he was back in the body and found himself looking confusedly into the faces of his companions, all of whom had felt something of the same uplift. Without a word, the Indian edged the canoe along the shore and into the mouth of a deep lagoon, half-hidden by overhanging trees. Beyond these it widened out and ended in a high, bare bank. Back from this stretched a narrow path, showing like a long line through the dark green of the jungle. Its surface was trodden ominously hard and smooth, as if crossed and recrossed by many bare feet.

"The Trail," said Pinto, softly.

"The Trail," echoed Professor Ditson, as they all stared along the thin line which pierced the forest and led away and across the vast basin of the Amazon and on and past the guarded heights of Peru until it reached the mines from which Spain had dug the gold which enabled her to conquer and hold half a world. Only the cruel, fierce, dogged fighters of Spain as she was four hundred years ago could have cut this path. Even then, when men thought little of life or of accomplishing the impossible, the Trail stood forth as a great achievement,



every mile of which had cost the lives of men.

For a time, the adventurers stared in silence at the brown line athwart the green, the sign and seal of an empire long passed away. Then Pinto grounded the montaria at the edge of the bank, and, after all of the party had disembarked with their scanty equipment, pulled the boat, with Hen's help, back of a screen of tangled vines, marked by a slender assai-palm, until it was completely hidden from sight.

"If we are successful," remarked Professor Ditson, "we 'll never see that boat again. If we are driven back along this trail, it may save our lives."

There was a silence. For the first time the boys and Jud realized that their leader definitely expected perils other than those ever present from the wild creatures that guarded the beautiful, treacherous, mysterious forests of this southern continent.

"Are the Injuns down here dangerous?" inquired Jud, at last.

"The personal habits of some of them do not commend themselves even to the most broad-minded investigators," returned the professor, precisely.

"Such as?" questioned Jud, again.

"Well," replied the scientist, slowly, "for one thing, the wild tribes of this part of the Amazon Basin invariably eat any captives they make. Then—"

"That 's enough," broke in Jud. "After I 've been eaten I don't care what they do next. What might be the names of these gentlemen?"

"The Muras, I think, are the tribe we shall be most likely to meet," said Professor Ditson, reflectively. "They have no fixed homes, but wander through the forest, guiding themselves by the sun, and sleep in the tree-tops like monkeys wherever they happen to be when night comes. They hunt men, red, white, or black," he went on; "yet if Indian traditions can be depended upon, we do not need to be afraid of them so long as we keep to the Trail."

"How 's that," inquired Will, intensely interested.

"Every tribe which refers to the Trail," the scientist informed them, "speaks of a custom called the 'Truce of the Trail,' under which travelers along that road are safe from attack."

"Does that there truce," interposed Jud, "take in white men, or is it only for redskins?"

"That," returned the professor, "is not certain. Some say yes, some say no."

"The question is," murmured Jud, "what do the Muras say?"

"If we pass the Trail in safety," went on Professor Ditson, "we still may expect trouble from Dawson after we get into the Peruvian highlands. He has great influence with a band of Indian outlaws who call themselves the Miranhas or Killers, and may persuade them to ambush us in order to secure the map."

"I sure am lookin' forward to this pleasure-trip of ours," confided Jud to Will.

During the first day along the Trail, Will, who was next to Pinto, tried to pass away the time by learning a few words of Mundurucu. His first lessons in that language, however, were somewhat discouraging, since the dialects of the South American Indians contain perhaps more syllables to a word than any other language on earth.

"Pinto," he began, "I 'll point to things and you tell me what they are in Indian and keep on saying it over and over until I learn it."

"All right," agreed the Mundurucu.

"Professor Pinto," went on Will, solemnly, pointing to his hand, "what 's that?"

"In-tee-ti-pix-tee-e-toke-kee-kee-tay-gaw," clattered Pinto, in a breath.

"Hey, hold up there," said Will. "Try it in low."

Half an hour later found him still working on that single word.

"Whew!" he remarked when he finally had it memorized, "I 've heard it takes eight years to learn Eskimo. It 's liable to take me eighty before I can talk Mundurucu. What about this one," he went on, undiscouraged, pointing to a curious tree with a mahogany-red bark which, if he had but known it, was a stranger whose seeds had in some way drifted down from much farther north.

"E-lit-ta-pix-tee-e-fa-cho-to-kee-not-e," said Pinto, slowly and distinctly.

For fifteen minutes Will wrestled with this new word.

"Do you know what he said?" at last interrupted Professor Ditson, who had been listening to the lesson.

"He gave me the name for that tree, did n't he?" returned Will, a little peevishly.

"Not at all," said the scientist. "He simply said, 'I don't know.'"

"Not so blame simply either," murmured Jud, who had also been following the lesson.

"Our own language is full of similar mistakes imported from native dialects,"

lectured Professor Ditson. "'Kangaroo' simply means 'I don't know' in Bushman, so do 'mosquito' and 'quinine' and 'cockatoo' in different Indian languages."

"Well," said Will, "I'm going to pass up Mundurucu. Here I've spent the better part of an hour in learning two words—and one of them is n't right."

"It's a gift, my boy," said Jud, patronizingly. "As for myself, I once learned three Indian languages, Apache, Comanche, an' Sioux in less than a month."

"Indeed!" broke in Professor Ditson, cuttingly. "You surprise me. Won't you favor me with a few sentences in Apache?"

"Surely," returned Jud, generously. "Ask me anything you like in Apache, an' I'll be glad to answer it in the same language."

The appearance of a small pond ahead put a stop to further adventure in linguistics, since Pinto had promised to catch some fish from the next water they met. As they came to the shore, suddenly, before Jud's astonished eyes, a fish about a foot long thrust its head out of the dark water, opened its mouth, and breathed like any mammal. A moment later it meowed like a cat, growled like a dog, and then went under.

"I'll never dare tell 'em about this in Cornwall," exclaimed Jud, earnestly, as the talented fish disappeared. "They'd think I was exaggeratin', an' that's one thing I never do. This trip," he went on reflectively, "is liable to make me believe blame near anything."

It was Professor Ditson who told them that the strange fish was a lung-fish and was a link between the fishes and the reptiles.

A little later, Pinto, with a length of flexible palm-fiber, noosed a garpike, that strange representative of the oldest family of fishes left on earth and another link with the reptiles. Its vertebræ had ball-and-socket joints like the spine of a snake, and, unlike any other fish, it could move its head independently of its body. Armored scales arranged in diagonal rows ran down its back and were fastened to each other by a system of hooks, instead of lapping over each other like the scales of other fishes. This armor was of such flinty hardness that Pinto struck a spark from it with his steel, and actually lighted, from its own scales, the fire on which the fish was cooked.

By this pond grew a great orchid with thirty-one flower-stems, on one of which Will counted over a thousand beautiful pearl-and-gold blossoms. Near the water,

too, were many varieties of tropical birds flaming through the trees. Among them were flocks of parrakeets colored green and blue and red, little honey-creepers with black, purple and turquoise plumage and brilliant scarlet feet, and exquisite, tiny tanagers like clusters of jewels with their lilac throats, turquoise breasts, topaz crowns, and purple-black backs shading into ruby red. These



"CURASSOWS, HUGE BIRDS, WHICH LOOKED LIKE TURKEYS"

were all searching for insects, while among the blossoms whirred dainty little humming-birds of the variety known as "wood-stars." Then there were blood-red macaws with blue and golden wings, and lustrous green-black toucans with white throats, red-and-yellow tail-coverts, and huge black-and-yellow bills. Once too they heard a solitaire sing. Out from the dark forest sounded eight liquid, melancholy notes which rose and swelled until there seemed to be nothing in the world except that beautiful voice; then at last it died away in a wistful sob.

For the next few days, the treasure-hunters followed the narrow, hard-beaten path through stretches of dark jungle and thorny thickets, or found themselves skirting lonely lakes hidden away in the very heart of the



virgin forest. Everywhere the Trail was ominously clear and hard-trodden. Sometimes they all had that strange knowledge that they were being watched, which humans who live in the open acquire as well as the wild-folk. At last there came a day when the supplies had run so low that it became necessary for Pinto to do some hunting. Will went with him, and together they silently and cautiously followed one of the many little paths that at irregular intervals branched off from the main trail. This one was so hidden by vines and creepers that it seemed improbable that any one had used it for a long period of time. It led the hunters into one of the patches of open country sometimes found in the forests of the Amazon. This particular one was fringed with great trees and crossed by another path nearly parallel to the one which they were following. Near the center of the clearing, Pinto managed to shoot two curassows, huge, plump birds which looked and tasted much like turkeys. Leaving these with his companion, the Indian pushed on ahead for more. Suddenly he reappeared among the trees and Will noticed, as he hurried toward him, that his copper-colored face showed gray and drawn, while beads of sweat stood out on his forehead. As he joined the boy, Pinto placed his finger on his lips with a look of ghastly terror and led Will into the deepest part of a near-by thicket. From there, though hidden from sight, they had a view through the close-set bushes of the other path. Suddenly, from far down that trail, sounded a faint, but regular, clicking noise. As it became louder and louder, rising and falling in a regular cadence, Pinto slipped like a snake deeper into the long jungle-grass.

"Lie still for your life!" he whispered in Will's ear, so faintly that the boy could scarcely make out the words. Then in an instant, from out of the jungle not twenty feet away, there strode along the dim path a figure of nightmare horror, that of a tall, naked man, with gaunt and fleshless arms and legs, great knobs of bone marking his knees and elbow-joints. His sunken body was painted black, with every bone outlined in a chalky white, so that he seemed a living, walking skeleton. Around the black and wasted neck, wrinkled like that of a mummy, hung a long string of small bones which, with a thrill of horror, the boy recognized by their nails as those of human fingers. It was these, striking together, which made the

clicking noise that Will had heard. The face of the horror was painted black, except the lips and chin, which showed blood-red, while out of holes at either corner of the lower lip protruded curved, gleaming, peccary-tusks. These ornaments gave an indescribably brutish appearance to the countenance which they ornamented, while above them two snaky black eyes, with an expression of implacable cruelty, glittered like crumbs of glass from under overhanging brows. Like a specter, the shape disappeared among the shadows, followed by another and another and another, until a long procession of terrible figures had passed. As the ill-omened clicking died away in the distance Will sprang to his feet.

"No," hissed the Indian, "our only chance of life is to lie quiet. That is a Maya war-party on a man-hunt!"

"They 'll meet the others on the Trail," whispered Will.

"Six men can't do any more against fifty than two," returned Pinto, practically. "We 'll only throw away our lives and not save theirs."

"Stay if you want to," returned the boy; "I 'll live or die with them!" And he sped back at full speed along the path over which they had come. Just before he reached the Trail he looked back, and there was Pinto at his shoulder.

"Very foolish," the latter muttered, "but—I come too."

Down the Trail the two hurried and, rounding a bend, burst in suddenly upon the rest of the party lying in the shade of the overhanging trees awaiting their return.

"Mayas! Mayas!" gasped Pinto.

As he spoke, far down the Trail from around a curve sounded the faint, ominous clicking which the two hunters had heard before.

It was then that the old scientist showed that he deserved the right to lead which he claimed.

"Stand still!" he said sternly to Pinto as the latter seemed inclined to bolt down the Trail away from the fatal sound. "Put up your gun!" he ordered Jud; "the Truce is our only chance."

Then with quick, decisive commands, he lined the party up so that no part of the body of any one of them extended beyond the surface of the Trail, and yet a space was left wide enough to allow any others using the path to pass. At the head of the line he placed the two Indians, Joe and Pinto, so

that the Mayas might note the presence in the party of members of their own race.

"Show the peace sign," he snapped sharply to Joe, who led the line. "Brace up!" he went on, slapping Pinto sharply on his bare

which he had killed old Three Toes, the grizzly, as already chronicled in "The Blue Pearl." "If I 'm goin' to be eaten," he went on, "there 'll be eighteen Mayas that ain't goin' to have any appetite for the meal," and he shifted the single clip of cartridges remaining, so that he could feed them into the automatic if it came to a last stand.

All further conversation was ended by the appearance of the same horrible apparition which had so terrified Pinto a short time before. As the gaunt painted skeleton of the first Maya showed against the green background, surmounted by the black and blood-red face with the grinning tusks and implacable eyes, an involuntary gasp went up from the whole waiting party. Jud slipped the safety-catch from his revolver; Pinto's face looked as if suddenly powdered with ashes; Will's hands stole to the hatchet at his belt; while down at the end of the line, Hen Pine gripped his heavy machete until his great muscles stood out like iron bands. Two of the party alone showed no sign of any emotion: Joe, the descendant of a long line of proud Chippewa chiefs, disdainfully stretched out both empty hands palms up in the peace-sign, while Professor Ditson's calm face seemed to show only the mild interest of a scientist. As the leading Maya caught sight of the waiting line he slowed his swift stride and the war-party crept up close and closer. Then came the tense moment which would decide whether



"THE WAR-PARTY CREPT UP CLOSER AND CLOSER"

back; "don't look so scared. No matter what they do," he said, turning to the rest of the company, "don't leave the Trail for a second or make any kind of attack on them. They will probably try to make us break the Truce of the Trail. If any of us do, we are all lost."

"My peace sign," muttered Jud, grimly, "will be an automatic in one hand an' this little toothpick in the other," and he opened the five-inch blade of the jack-knife with

the Truce was to hold. As the grim hunters moved up, there was no sign on the face of any of them of any acceptance of the peace which Joe had offered. With short, gliding steps, they made a complete circle around the little party, closing up until their menacing, fearful faces were less than a foot away and the reek of their naked bodies was like the hot taint of jaguars of the jungle in the nostrils of the waiting six. In their left hands they carried bows and quivers



of fiercely fanged arrows gummed with fatal venom, while from their belts swung curved, saw-toothed knives and short heavy clubs, the heads of which were studded with alligators' teeth. As they came closer, the waiting line wavered involuntarily before the terrible menace of their hating, hateful faces. The Mundurucu, especially, although no coward, had been taught from earliest childhood to dread these man-eaters, the Mayas. It was Professor Ditson who noticed that, in spite of their menacing approach, not a single warrior had as yet gripped a weapon.

"Steady, Pinto, steady all," he said calmly. "They 're trying to stampede us. If one of you leaves the Trail, we 're all dead men."

He spoke only in time, for already Pinto was looking longingly towards the refuge of the forest, forgetting that the woodcraft of those hunters of men was superior even to his own. Perhaps even Professor Ditson's voice would not have stopped him if it had not been for a sudden happening. As the leader of the Mayas half circled about Joe, the latter turned to face him, still holding his arms out. The motion flung open his flannel shirt, unbuttoned to the waist, and showed, tattooed red on his brown skin, the curling, twisted totem-mark of intertwined serpents by which Joe had claimed the right of his blood in the lodge of the Great Chief during the quest of the Blue Pearl. As the Maya caught sight of this sign he stopped in his tracks. Little by little the menace died out of his fierce eyes; and as if drawn by a magnet, he crept in closer and closer with outstretched neck, staring at the tattoo marks which wound down and around Joe's waist. Then, with a sudden gesture, he swept aside the ghastly necklace which he wore. There, outlined against his fleshless chest, just over the heart, showed a similar emblem—crimson, intertwining serpents facing in opposite directions, with gaping mouths like those of which the totem-pole was made which towered before the lodge of the Great Chief in far-away Akotan. The Maya chief stood motionless for a moment. Then he stretched both hands out toward Joe, palms up, and stood as if waiting.

"Put your hands in his, boy," hissed Jud, from down the line; "he 's waitin' for the brotherhood sign."

Without a word, Joe clasped hands with the Maya chief and for an instant the two looked into each other's eyes, the spectral cannibal and the lithe son of a French trapper

and a Chippewa princess. Then, disengaging his right hand, the Maya fumbled at his belt and suddenly stretched out toward Joe the supple, beautifully tanned skin of a snake, such as but one of the party had ever seen before. It was long and narrow and of a gleaming golden-yellow, thickly flecked with tiny red-brown spots. This he wound about the boy's neck, so that it swung gleaming against his gray flannel shirt. Once again with outstretched hands the strange figure stood as if waiting, encircled the while by fierce, impassive faces, with tusks gleaming horribly against blood-red jaws, and white painted bodies showing like ghosts against the green of the forest.

"Give him your tie," directed Jud. "Don't you know blood-brothers have to exchange presents?"

Joe hesitated. He had a weakness, perhaps inherited from both sides of his family, for neckties of the most barbaric colors. The one that he was wearing was one of Cornwall's best and brightest, a brilliant green-and-purple creation which had cost him a whole dollar at White Wilcox's store. To give it up would leave him tieless in a great wilderness.

"Hurry!" muttered Professor Ditson, as the Maya chief began to lower his outstretched hands.

Thus urged, the boy reluctantly pulled a foot of glittering silk from his neck, and the next instant the most brilliant tie that ever graced Mr. Wilcox's emporium was gleaming against the gray-white of a necklace of human bones. The Maya received the enforced present with a grunt of undisguised pleasure, and, raising both hands above his head with palms still outstretched, faced his waiting band and began a crooning song filled with strange, minor cadences. One by one his men took up the strain, and, led by him, filed away along the Trail like ghosts going back to their graves. As the clicking of their necklaces and the notes of their chant sounded faint and fainter and at last died away in the green tangle of the jungle, a long sigh of relief came unconsciously from every member of the expedition. It was Jud who first broke the silence.

"I 've always heard," he said, "that Injuns north, south, east, an' west belonged to the four main totems, the Bear, the Wolf, the Snake, an' the Eagle, but I never believed it before to-day. That old tattoo-mark, boy," he went on, turning to Joe, "certainly came in right handy."

"He gone off with my good tie," returned Joe, sorrowfully.

"And a good job, too, I call it," remarked Will, who had never approved his friend's taste in neckwear.

It was the Maya's present which most interested Pinto and Professor Ditson. The Mundurucu Indian sidled up close to Joe and stared at the glittering skin with all his eyes, but without attempting to touch it.

"It 's the Sacred Snake that in the old days only kings and gods could wear," he murmured.

"He 's right," said Professor Ditson, raising the gleaming, golden skin reverently from Joe's neck. "It 's the skin of the Yellow Snake, which the Aztecs used to wind around the forehead of their terrible war-god. Only his priests knew where these snakes were to be found, and it was death for any one else even to look at the skin except at the annual sacrifices of the god. This one," he went on, "will be a safe-conduct for the whole party all the way to Peru, and ought to be a lesson to you," he continued severely, turning to Jud, "never to speak against snakes again."

(To be continued)

## HOW THE DECLARATION OF INDEPENDENCE WAS FIRST MADE KNOWN TO THE PUBLIC

By GARDNER TEALL

UNCLE TIMOTHY, Billie, and Marion had been talking over the family plans for Fourth of July. Billie had suggested illuminating by a row of little bonfires at the top of the hill. "Then," said he, "it would be just like the bonfires they had the first Fourth of July."

"That reminds me," said Uncle Timothy, "that the first Fourth of July was n't a fourth of July at all!"

Billie and Marion looked up in surprise.

"Why," said Billie, "who ever heard of a Fourth of July that was n't a Fourth of July!"

"Well," laughed Uncle Timothy, "it does n't *sound* reasonable, but you can work it out without arithmetic if you peep into history a bit."

"Is it a story, Uncle Timothy?" asked Marion.

"Almost," Uncle Timothy replied; "at least I have always considered it a story, and a good one too."

Billie and Marion settled down to listen, and Uncle Timothy began:

"The American colonies were forced to declare their independence, all because of the destructive policy of King George III. of Great Britain, acting on his own initiative, and *not* through any wish on the part of the English to oppress the colonists. The king was arrogant, incapable, and amazingly

blind as to what must be the inevitable result of his treatment of the colonies. He refused the counsels of the many able English statesmen who themselves well knew what the king's course would lead to. They fully realized that the majority of the king's subjects felt that the colonists had not been fairly treated, and all on account of the king's stubbornness and his willingness to listen to the sinister advice of his favorites. The English people did not want war and were distressed at the thought of fighting their own kith and kin, for it amounted to that. However, the king willed it otherwise, and for a time the power was his; and as a consequence his American colonies were forced to declare their independence of his rule. You children will find, if you stop to think of it, that the Declaration of Independence went forth as an indictment against King George III, and *not* as an indictment against the English people."

"I thought," said Billie, "that the colonists were fighting the British."

"Well," Uncle Timothy explained, "some of our histories make it seem that way; but when the Americans fought the king's armies they were fighting the king's tyranny and with sorrowful thought of feeling obliged to sever the political bonds which had held them to the mother country. Look in the Declaration of Independence and you will



find this sentence: 'The history of the present king of Great Britain is a history of repeated injuries and usurpations, all having, in direct object, the establishment of an absolute tyranny over these states.'"

"I see," said Billie. "I 'm glad it was n't the other way."

"It must have been hard to start a new nation without feeling awfully homesick," Marion ventured.

"New nations," said Uncle Timothy, "are

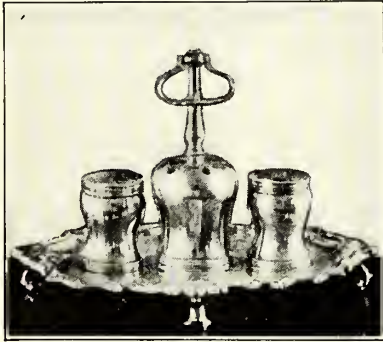

SILVER INK-WELL, SAND-BOX, AND QUILL PEN-HOLDER USED IN SIGNING THE DECLARATION OF INDEPENDENCE

not exactly 'started' in a day. The principles for which the colonists stood were, indeed, the common heritage of all English-speaking people, and the fact that George the Third refused to recognize the rights of the colonists (although he did those of his subjects in England) made these principles, the development of centuries, the bed-rock of the new nation, the strength of whose nationalism was to develop as time went by.

"Indeed," Uncle Timothy went on, "a noted historian, John Richard Green, once wrote: 'From the hour of American independence, the life of the English people has flowed not in one current, but in two. . . . But distinct as these currents are, every year proves more clearly that in spirit the English people is one. The distance that parted England from America lessens every day. The ties that unite them grow every day stronger.'"

"Miss Pettipher read us something like that last term," said Marion. "Now I understand it better."

"Then," Uncle Timothy continued, "you will remember that when it became necessary to dissolve the political bonds which connected the American colonies and England, Richard Henry Lee, of Virginia, introduced in the Continental Congress, sitting in the

old state house at Philadelphia, his famous resolution moving 'That the United Colonies are, and of right ought to be, free and independent States.' After two days of debate on the subject, the Congress appointed Thomas Jefferson, John Adams, Benjamin Franklin, Roger Sherman, and Robert Livingston as a committee to prepare a declaration of independence. For ten days this committee worked industriously on the document, and rendered their report June 28, 1776. On the first of July, Lee's resolution was again considered. Two days later, Jefferson completed the final draft of the Declaration, but it was not until the evening session of the next day, July 4, that the Declaration of Independence was adopted, and John Hancock, as president, and Charles Thomson, as secretary of the Congress, dipped their pens in the silver ink-well made by Franklin's friend, Philip Syng, the Philadelphia silversmith, and placed their signatures on the document. The other delegates to Congress did not sign the Declaration till some days later. Now as all these sessions of the Congress were held in secret, it was not, in fact, till after July 4, 1776, had come and gone that the people of Philadelphia, of Pennsylvania, and of the other colonies knew that this particular day was the cradle-day of American independence. So you see, there could have been no public celebration of the event on that first Fourth of July."

"Why," said Billie, "I always thought they built bonfires, rang the Liberty Bell, lighted up all the houses, went around shouting, just as on Armistice day, and everything!"

"They always make pictures of it that way," said Marion.

"I suppose they do, but not always," said Uncle Timothy; "and as for bonfires, ringing the Liberty Bell, illuminations, shouting, and everything, all this did take place, only not till afterward."

"When?" asked Billie.

"I 'll tell you," said Uncle Timothy. "When Mr. Hancock and Mr. Thomson had finished signing the Declaration, Congress ordered that it be authenticated and printed, that the committee appointed to prepare it should superintend and correct the printed copy, and that copies should be sent to the several assemblies, conventions, and committees or councils of safety, and to the commanding officers of the Continental troops, and that the Declaration of Inde-

pendence be proclaimed in each of the States, as the colonies were now to be called, and at the head of the army."

"They sent one to George Washington, then, I suppose," said Billie.

"Yes," said Uncle Timothy, "they sent one to General Washington as commander-in-chief of the American forces. Before adjourning the evening session, Congress in these words further ordered: 'That the Sheriff of Philadelphia read or cause to be read and proclaimed at the State House in the city of Philadelphia on Monday, the Eighth Day of July instant, at twelve o'clock at noon of the same day, the Declaration of the Representatives of the United Colonies of America, and that he cause all his officers and the constables of the said city to attend the reading thereof.' It was further resolved that every member of the committee in or near the city be ordered out to meet at the committee chamber and to proceed from there to the state house to be present at the reading in public, or proclamation of the Declaration. Likewise the Committee of Inspection and Liberties was requested to attend."

"Was that the first time the people heard the Declaration?" asked Marion.

"The very first time," said Uncle Timothy. "You will remember that up to the time of the reading in public, the deliberations of the committee and of Congress were in secret. When the secretary of the Congress finished writing up his minutes at the close of that memorable evening session of July 4, he probably rolled up the copy of the Declaration which he and Mr. Hancock had just signed, and on his way out handed it to John Dunlop, the Philadelphia printer who attended to the printing of all records required by Congress. It was Dunlop's task to get the written copy into type at the earliest moment and to see that the printed copies were free from errors. From a printed copy of this sort, the Declaration was first proclaimed."

"And did the sheriff of Philadelphia read it from the balcony of the state house?" asked Billie, who had once been on a trip to Philadelphia and thought he remembered seeing a balcony on Independence Hall.

"No," said Uncle Timothy; "as a matter of fact, the sheriff himself did n't read the Declaration at all, but for some reason delegated the honor to Colonel John Nixon, who had a fine, powerful, and far-carrying voice. Perhaps the sheriff's was squeaky."

"Who was Colonel John Nixon?" asked Marion.

"He was a prominent patriot," Uncle Timothy replied, "and his name ought to be known to every boy and girl in America as the first person to read to the public the Declaration of Independence. This day of



COLONEL NIXON READING THE DECLARATION IN PHILADELPHIA—AS IMAGINED BY AN ENGLISH ARTIST

July 8, 1776, he was a comparatively young officer of forty-three. Colonel Nixon had been a member of the First Committee of Correspondence in Philadelphia, was made a lieutenant-colonel in the Continental Army in 1775, and in 1776 was in command of the defenses of Philadelphia, in which year he was promoted to the rank of colonel."

"I wonder why our school history does n't say more about him," said Billie. "He must have looked fine up there on the balcony."

"Perhaps they will, some day," said Uncle Timothy; "and I suppose, as he was a man of commanding presence, that he did look fine as he took his place to read the Declaration. But it was n't on a balcony above the heads of the people that Colonel Nixon stood; it was on a platform in their midst, a platform which, some years before, the Philo-



sophical Society of Philadelphia had erected in the state house yard for astronomical purposes connected with the observation of the transit of the planet Venus. Here Colonel Nixon took his stand, and slowly,

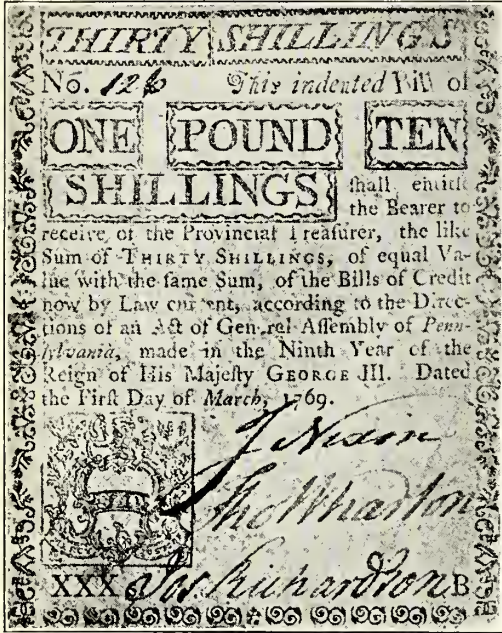

THIRTY-SHILLING COLONIAL CURRENCY NOTE  
BEARING COLONEL NIXON'S SIGNATURE

distinctly, and impressively read the Declaration from beginning to end to the hushed gathering about him, a gathering which realized the tremendous significance of the words they were hearing. As he finished reading the document, though his voice had been firm, there may have been a slight

tremble in the last word from the emotion the reader could not but have experienced."

"What did the people think of it?" asked Marion.

"Well," said Uncle Timothy, unfolding an old newspaper, yellow with age, which was lying on the table in his study, "you can see for yourself."

Billie and Marion glanced at the old paper and discovered that it was a copy of the "Philadelphia Gazette" of 1776, and this is what they read:

Philadelphia, July 8, 1776.—This day the Committee of Safety and the Committee of Inspection went in procession to the State House, where the Declaration of Independency of the United States of America was read to a very large number of the inhabitants of this city and county, which was received with general applause and heartfelt satisfaction.

"My!" exclaimed Billie, "that paper must be a valuable relic."

"It is," said Uncle Timothy; "and so is this little square of buff-colored paper. Look at it carefully and you will see that it is a thirty-shilling Colonial currency note, the sort of paper money then in use; and here you will see that it bears the actual autograph signature, boldly written, of Colonel Nixon himself. He was, when this came from the press, one of the committee appointed to sign the notes, just as the bank-notes of to-day are signed by officers of the national banks which issue them."

"It's wonderful!" said Billie and Marion in one breath. "Things like this seem to bring history much nearer."

"Well," said Uncle Timothy, "it's my opinion that this is just what they're for."

## A VAGABOND BEE

By CLINTON SCOLLARD

DOWN the seas of air uncharted,  
O my rover, honey-hearted,  
With no vexing tides to veer you,  
For what port, what haven, steer you?

Glowering tempests gloom not o'er you;  
You have happiness before you—  
All the treasure-ward of tillage,  
Endless towns of bloom to pillage!

I, like you, would wander, wander,  
Through the bright blue ether yonder,  
On the currents, clover-fragrant,  
Just a careless, voyaging vagrant!

Then, my rover, golden-belted,  
Attar-scented, pollen-pelted,  
Life would seem so blithely cheering  
Going bravely buccaneering!

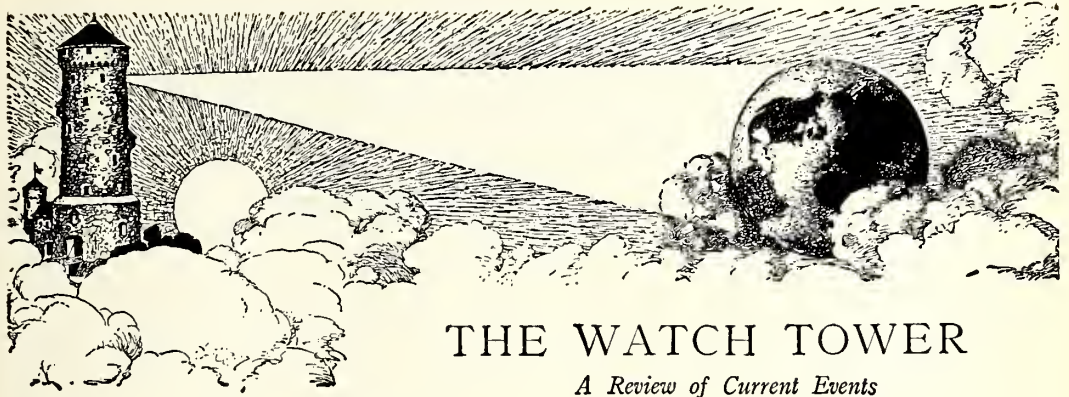

## THE WATCH TOWER

*A Review of Current Events*

By EDWARD N. TEALL

AMERICA has traveled far since the old Liberty Bell rang out its message that independence had been declared. The little nation of those days has become the greatest power in the world.

In 1776, the American nation occupied a small part of a continent so large that many folks must have thought it would develop, like Europe, into a number of separate countries with a corresponding number of governments. The idea of a nation extending from coast to coast and from the Lakes to the Gulf can have been entertained only by the few who possessed the boldest imaginations.

But the little nation grew and prospered, State after State came into the Union, and to-day 110,000,000 people live in our 3,000,000 square miles of territory. Naturally, their government is a rather different matter from that which was needed a century and more ago. Also, the relations of America with the rest of the world have become such as the founders of this nation, with all their wise foresight, can hardly have dreamed of.

Nevertheless, America is still America, the Land of the Free. Its ideals are the same; its influence in the world is such as Washington, Lincoln, and all the great leaders of our national youth would approve.

The soul of America lives to-day as it lived in 1776. As the Glorious Fourth comes round again, we "have a right" to hold our heads high and rejoice in the greatness and the unsullied honor of this mighty nation, Our America.

### CIVIL WARS OF POLITICS

AN American election is like a little civil war, with ballots instead of bullets. The people take sides and fight with a good deal of bitterness; then the votes are counted,

the results announced, the victors and the losers congratulate each other, and everybody goes back to work. Sometimes our elections decide issues over which some other countries would have a real civil war, with guns and swords and serious casualties. The American way of managing a revolution is a mighty good one. It does not break the hearts of mothers!

The Presidential elections are really quite fairly to be described as revolutions, for they involve not merely the selection of new administrators, but extensive changes in governmental policies. The differences in party principles are essential enough to influence powerfully the welfare of millions of citizens. Fortunately, the same Americanism that makes it possible for the voters to fight their battles in this peaceful way rules the conduct of our public officers, and the party in power puts national progress ahead of everything else—or quickly goes out of power.

Between the Presidential elections, we have the lesser battles of the state elections. Congressional elections offer the first real test of the popularity of a national election. The election of a governor often gives a line on what the people of the State think of the record of the administration at Washington, and the election of a United States senator works the same way—perhaps even more so!

This spring there were several campaigns under way that furnished the political prophets with material for predictions.

In Missouri, Senator Reed, Democrat, was a candidate for reelection. His opponent in the primaries was Breckinridge Long. Mr. Reed is a mighty independent sort of statesman; he says what he happens to think—



and some of those who don't like him say he often talks without thinking enough first. He had back of him the power of the Democratic organization. Mr. Long is a much younger man, without Senator Reed's experience in politics. Ex-President Wilson expressed himself strongly against Senator Reed as a Democratic choice.

In the elections in which Senator Reed will ask the people of Missouri to send him back for another term and Senator Johnson will make a similar appeal to the voters of California, progressivism and stand-pattism will influence the result. Are the voters tired of reform campaigns? Do they want

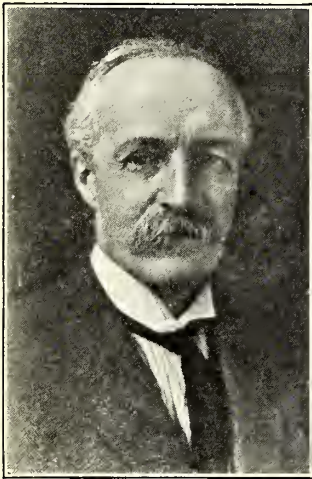

© Underwood & Underwood

GIFFORD PINCHOT

a quiet period of party regularity? THE WATCH TOWER does n't prophesy; it is interested in future events only for the sake of helping its readers know what principles are involved in coming struggles, and to give them help in making up their minds which side to be on.

The primary elections in Pennsylvania in May were extremely interesting, particularly the Republican vote for a candidate for governor for the fall election. Gifford Pinchot was the candidate of the more progressive element; Mr. Alter was the choice of the party organization. It was thought that Mr. Pinchot might make a close thing of it, but almost everybody was surprised when he won the fight.

The administration has been quietly effective, and has made in its first year and a quarter of responsibility a commendable record in the "return to normalcy." It is a business administration, not one devoted to ideals—and yet in the Washington Conference it rendered a service that the most zealous idealist must recognize as unparalleled in history for the realization of the highest ideals of service to mankind. But in domestic affairs it is what its critics like to call, without complimentary intention, a reactionary administration; that is,

one that is satisfied to manage its business in the old-fashioned way.

It is n't good to be too reactionary, and it is n't good to be too progressive. (As the little girl in the back row says, most wisely, it is n't good to be *too* anything!) And the elections of the past few months, while not alarming to the friends of the present administration, have shown enough voting power on the side of Progressivism to make the folks at Washington realize, if they have as much good sense as we give them credit for, that the country expects them to go ahead pretty steadily on the program of "reconstruction" on which they were elected to national office.

### IRELAND MOVES ALONG

SINCE last we looked at Ireland, progress has been achieved in the island whose long history of trouble makes so stirring a part of the story of mankind. In May, plans were being shaped for an election to be held in June which offered the welcome possibility that the Irish people might soon start their free-state government going with the power of a united Ireland behind it.

Looking forward to this important election the people appeared to be divided into two parties. One was composed of those who would be satisfied with nothing short of complete separation from the British Empire and the immediate establishment of the republic. The other was composed of several elements: those who favored full acceptance of the treaty with England, those who believed in accepting it as a first step toward independence, and those who merely saw in it a way to avoid civil war.

Three matters were to be settled by the voting: the voters were to endorse or reject the action of the delegates who signed the treaty; they were to vote for or against the constitution under which the provisional government had been working; and they were to elect their representatives in the Irish parliament. If they accepted the treaty, the way would be clear; but if they rejected it, everything would be set back to where the period of progress began last summer. The situation was surely one of the strangest that ever was known!

The republicans objected to the plan to hold the election in June because the voting lists had not been recently revised, and they thought a new list would work in their favor, adding names of voters who would oppose



© Underwood & Underwood

A PHOTOGRAPH AS ARTISTIC AS A PAINTING—A CAVALRY CHARGE OF NATIVE TROOPS ORDERED AS A MARK OF HONOR FOR PRESIDENT MILLERAND DURING HIS RECENT VISIT TO ALGIERS

acceptance of the treaty. But Mr. Griffith and Mr. Collins insisted on an early election.

When this number of *THE WATCH TOWER* was written, there were several incidents, "minor" in themselves, that seemed clearly to indicate, when considered together, that the tide was turning in favor of peace and the acceptance of the treaty.

If democracy means decision by the majority of the people and acceptance of such decisions by the minority, then Ireland has been passing through a test of democracy almost without a rival in history.

#### FRANCE IN AFRICA

THE Mohammedan world is astir, and there are some observers of current events who think the time is coming before long when the East will rise against the West and the great war of the civilizations will begin. While we of *THE WATCH TOWER* are not easily excited and prefer to take things as they come, it is an undeniable fact that there is a great restlessness in India and Africa that may possibly have very serious results.

France is awake to these possibilities. In the spring, President Millerand visited the French territories in Africa. The object of the visit was to get into touch with the natives and gain their good will.

Many stirring spectacles were arranged for the entertainment of M. Millerand. One of them, the charge by Algerian horsemen shown in the picture, reminds us of the old days of fighting in the desert. The picture is certainly so full of action as to quicken any pulse. What a dashing gallant charge it shows!

We print it not to glorify war, but for its purely picturesque interest, for it is merely part of a pageant arranged in the interest of peace and friendship.

#### GENOA WAS NOT A FAILURE!

IN mid-May, when the Genoa Conference was about to adjourn, to reassemble in June at The Hague, there were many persons who thought the conference had been a flat failure. Well, there are people who find the news of these days tedious, and think pretty nearly everything a failure.

Truly, these are extraordinary times. Men have great problems to make life worth while. It is a splendid thing to have an opportunity to start fresh and make the world over. You can not pick up a newspaper without finding reports of wonderful enterprises, requiring wisdom and courage and offering a rich reward to those who earn it by their conduct.



The Genoa Conference revealed clearly as a fact what had often been discussed as a theory—the complete interdependence of all countries economically. There was a time in America when a man with a bit of land could get along all by himself. But now each one depends upon the work of others for almost everything he needs, and earns

unless they can be sure that they will have fair play; that their rights will be protected and their investments made safe.

The United States, giving generously to help the sick and the starving people of Russia, will not recognize her officially until she has a steady and trustworthy government. Meanwhile, anybody who wants to



Wide World Photos

FOURTEEN SWEDISH LOCOMOTIVES READY FOR DELIVERY TO RUSSIA, THE FIRST OF AN ORDER OF 950

the price of it by doing one small part in the work of producing something that others want. And in the same way the nations are dependent upon one another in business.

The truth of this assertion was shown in the relation of Russia to the other European countries. Russia has tried to get away from the business system followed everywhere else—to substitute national ownership and management for private property and individual enterprise. And Russia has gone bankrupt. In addition to the hardships caused by the war, she has suffered from the difficulties of doing business on a socialistic basis.

Russia has had billions of dollars' worth of help from other countries, especially the United States. She wants to sell them her goods and buy theirs. She can't be self-supporting unless she does. But other countries are not going to trade with her

do business in Russia, on his own responsibility and taking his own chances, is just as free to do so as the soviet power will permit. No other power has blockaded any Russian port or forbidden its people to trade with Russia.

By the middle of May it had become clear that the Russian question was the core of the problem. And that was a gain—not a wholly pleasing one, but a useful one. What had been uncertain had been made certain. And the recess for study of what the other nations could do and what Russia was willing to do to gain their business friendship was a step toward further progress. The agreement among the powers that they would keep the "truce" and make no separate treaties with Russia held the way open.

The United States adopted a clear policy at the beginning. European governments were eager to have us join them, but we said

that certain things must be done before we could do so. If they could not do those things alone, it was hardly likely that they would do them at the suggestion of American delegates. And it was refreshing to see the administration outline a policy—and stick to it.

But as to failure of the conference—well, you don't order a house built and then tell the contractor he has failed if he does n't have it ready for you to move into in a week! And Europe can not be rebuilt in a month!

We have a long, long hill to climb, and it's slow work. But we're on our way!

### ALASKA'S RAILROAD

IN these days when we are thinking so much about Russia, it may be especially interesting to consider what is going on in Alaska, which we bought from Russia long ago. Our northern Territory fell off in population in the last census period, and people have been wondering what is the matter and what can be done to make Alaska prosperous.

One step in that direction was taken when the Alaskan Railway was opened, early in this year. The railroad was the result of the planning and energy of Secretary Lane. He gave the project its start, and through the long and difficult process of building the line he directed the work. As long as cars roll over those rails and locomotive whistles rouse echoes in the mountains, that road will be a monument to his wisdom, patience, energy, and courage.

The railroad runs from Seward, on the coast, to Fairbanks, 467 miles away in the interior. It cost \$78,000 a mile to construct it—and there's a problem for our class in multiplication: At \$78,000 a mile, what will 467 miles of railroad cost, if the ties are ten inches apart and the rails weigh 100 pounds to the yard? Building the government railroad across the Isthmus cost more than \$200,000 a mile, and the difficulties of that engineering enterprise were matched in Alaska by the rough nature of the country traversed, by the cold and snow of the far northern winter, the tunneling, and the building of snow-sheds and trestles.

The Alaskan Railway provides transportation for coal from Matanuska and Nenana to the coast; it makes it easy to get the product of other mines to a shipping point, and it removes one difficulty in the way of profitable farming.

Now that the Alaskan Railway is in operation, we ought soon to know whether our Territory in the north can realize the hopes its friends have long had for it.

President Harding is to make a vacation trip to Alaska this summer, and it is certain that he will want to see the new railroad. The people of the Territory will give Mr. Harding a royal reception. They do not often have the chance to greet a President of the United States up there!

### THROUGH THE WATCH TOWER'S TELESCOPE

THE Washington Conference created several commissions to take charge of arrangements in China for management of property and the safe-conduct of business. They have had trouble because of the absence of a responsible government with which to deal. President Hsu of the Republic of North China and President Sun Yat-sen of the Republic of South China have been contending for power, and General Wu of the north won a victory over General Chang of the south. General Wu is anti-Japanese and eager to make China free and independent. American marines are guarding our property and interests.

A NOTABLE happening in May was the meeting, at Washington, of delegates from Chile and Peru to try to settle peacefully the dispute over the Tacna-Arica boundary-line. The United States Government had offered them the hospitality of our capital. Uncle Sam was not willing to act as referee, but he was glad to be able to have the conference held in this country, and to help as far as he could without involving himself in the dispute. The conference opened with every indication that a determined effort would be made to get the long-standing differences of opinion adjusted.

THE Supreme Court has ruled that the child-labor law is unconstitutional. This decision is based on the fact that the law gave to the Federal Government powers reserved to the States. Everybody—except those who make the law necessary—wants to see the conditions of employment of children in industry regulated, and it is to be hoped that all the States may see the wisdom of uniform laws on this subject, or that an amendment to the Constitution for its regulation may be made without delay.



## NATURE AND SCIENCE FOR YOUNG FOLK

### MAKING THUNDERBOLTS TO ORDER

OF all the phenomena in nature, none is so impressive, perhaps, as that of thunder and lightning. It is both majestically beautiful and profoundly awe-inspiring to see the heavens apparently torn asunder by streams

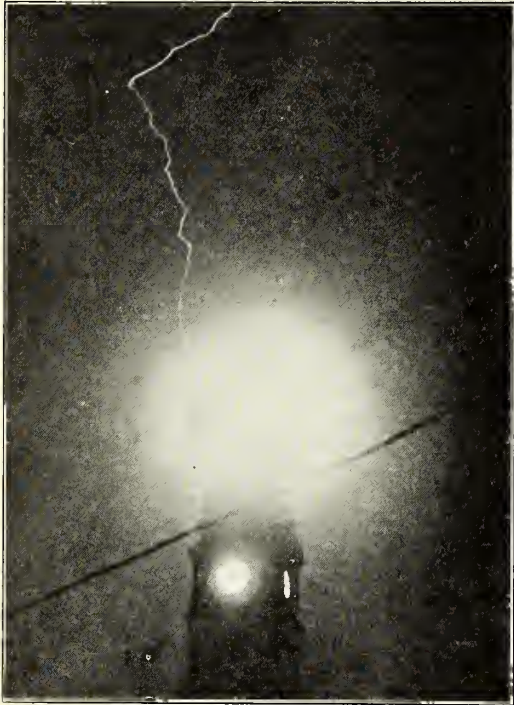

THIS REMARKABLE PHOTOGRAPH SHOWS A CLOCK TOWER AT THE INSTANT IT WAS STRUCK BY LIGHTNING

of fire. Our own Bible is full of references to thunder and lightning as dread evidences of the Creator's power and wrath; while in the Pagan writings of Greece and Rome, we find that the thunderbolt was an attribute of the mightiest deity in their mythology—of Jove the thunderer.

It was our American philosopher and statesman, Benjamin Franklin, who first learned by means of a daring experiment, which might well have cost him his life, that lightning is really a manifestation of electricity. When two clouds, or the earth and a cloud, are charged with different kinds of electricity (positive and negative), there is a discharge from one to the other when the tension becomes sufficiently great; and in leaping across the gap between the two, part

of the electricity is changed into heat and light, due to the resistance of the air through which it must pass and which is a poor conductor of electricity. However, it varies in the amount of resistance it offers, for one reason or another (especially according to the amount of vapor it contains), and for this reason the lightning, which always takes the path of least resistance, is apt to be forked or zigzag. In the accompanying picture, which is an unusual one, the flash followed almost a straight line. Sometimes these lightning flashes are as much as a mile or more in length. It has been estimated that a flash a mile long is caused by a voltage of three and a half million volts (the term voltage being used as a measure of the tension or pressure of the electricity).

Lightning also occurs in the form of sheet-lightning, which all of us have seen illuminating for a moment a large area of the sky with a soft glow, and more rarely as ball-lightning. In the latter form, it is particularly startling, since fiery globes as much as a foot in diameter are sometimes seen. Occasionally, too, they explode, thus adding to the terror which they inspire.

But it is only within the past few months

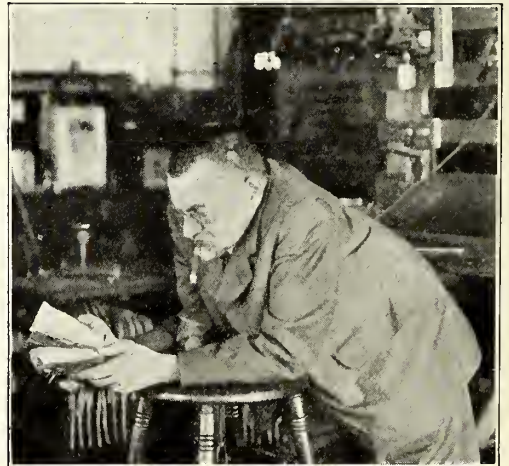

CHARLES P. STEINMETZ EXAMINING THE BRANCH WHICH WAS SPLIT BY ONE OF HIS MADE-TO-ORDER THUNDERBOLTS

that it has been found possible to imitate the effects of lightning in the laboratory. The distinguished electrical engineer, Charles P.

Steinmetz, of Schenectady, New York, recently accomplished this, and the made-to-order thunderbolt discharged from his apparatus split the branch of a tree in exactly the same way that natural lightning does. This operation has a certain practical value,—not for making kindling-wood!—but for testing the efficacy of the apparatus called lightning-arresters, whose object it is to protect telephone and telegraph wires and their operators.

M. TEVIS.

### THE COLUMBINE'S JOKE

THE big lumbering bumblebee, in her gorgeous dress of gold and black, seems to realize that she is a favored guest of the beautiful garden columbine, and comes buzzing among the delicate inverted flowers with the assurance of one certain of a pleasant reception.

Lighting in her clumsy, bungling way, she clings upside down; and as her head is thrust into one after the other of the deep trumpetlike tubes, the frail blossoms are set a-tremble. But she is a recognized friend and benefactor; and though she may seem a little rough at times, the flowers are ever ready to welcome her visits.

However, innocent and sedate as these beautiful blossoms appear, they seem to be not lacking in a sense of humor, and sometimes, as Mrs. Bombus is busy searching out the hidden sweets, they play a prank on the lady that, while extremely amusing to witness, is most disconcerting to her. The younger flowers seem not yet to have learned the trick, but it is when the bee gets to poking her nose into the affairs of the older blossoms, those whose petals are about ready to fall, that the joke is played.

In the endeavor to reach the secreted nectar with her long tongue, she forces her head deep into the flower tube, which, due to this rather strenuous performance, becomes detached from the stem, so that, when she tries to withdraw, the little trumpet-shaped tube, now entirely incasing her head and shoulders, breaks away from its anchorage and clings to her. With this dainty little bonnet, like a gorgeously tinted fool's cap fitting snugly about her head, she is totally unable to see where she is going and presents a comical sight as she flounders about in her frantic efforts to free herself from the unwelcome head-gear.

Down through the dense mass of leaves, twisting and squirming, she tumbles, finally

reaching the soft ground beneath. Here, somehow, in her blind struggling, she manages to wiggle out of her uncomfortable extinguisher. Then, after gathering her shattered wits together and finding herself none the worse for the exciting experience, she laboriously works her way up among the



THE HONEY CUP THAT BECOMES A FOOL'S CAP

leaves to the open air and sunlight, and, buzzing an angry protest, flies away in disgust; while the flowers mildly nod their dainty heads in the gentle summer breeze as if appreciating the humor of the occasion.

GEORGE A. KING.

### INSECTS TO FIGHT PESTS

INSECTS too small to be seen by the naked eye have in recent years been brought from India in an attempt to relieve the orange orchards of Florida from the ravages of the winged pest known as the citrus white-fly, of which these tiny insects are the natural enemy. Of microscopic size, the foe of the citrus-fly staggers under the portentous name of *Prospatella lahorensis*. The introduction of this insect into the United States is attended with numerous difficulties, owing to its being a very poor traveler. Living within the body of the white-fly



larvæ, the parasite *Prospatella* thrives only in districts infested with these pests, and as the white-fly, in turn, can exist only upon the leaves of the citrus trees, it was found

on the Clark farms. The wheat contained a dark chaff, the straw was taller and appeared sturdier than the Turkey-red wheat which covered the field, and the grains

were plumper and darker.

Because he had been taught by his father to be observing and always on the lookout for anything which might advance the cause of better farming, the lad picked the strange wheat and carried the heads to his father, who was deeply interested and told his son that it looked like fine wheat.

That fall, Earl, without any one's advice, dug a furrow seven feet long and planted the seed. This row of seed produced three and one half pounds of wheat, and the next autumn he seeded seventy square feet. From this sowing, enough

wheat to seed one seventh of an acre was threshed. Within a year or two, enough of the new variety of grain had been produced, under Earl Clark's persistent efforts, to seed



TINY DEFENDERS OF OUR ORANGE GROVES EN ROUTE FROM INDIA TO AMERICA

necessary to import the three together. Young potted orange-trees were allowed to become heavily infested with both the citrus-fly and its enemy.

The plants were then packed in "Wardian" cases,—a kind of portable greenhouse,—and started on their ten-thousand-mile journey to the United States.

H. E. ZIMMERMAN.

### THE BLACK-HULL WHEAT

AFTER starving Armenia has passed through its present dangers, it will be given a chance to sow its fields and start upon a new era in the growing of grain through the use of a remarkable variety of wheat, discovered by a fifteen-year-old boy of Harvey County, Kansas, Earl G. Clark.

The wheat is now known as Clark's Black Hull, and a bushel of it was included in the shipment of a train-load of flour which was sent to Armenia by the International Wheat Show as an important part in the plan of reseeding Armenian wheat-fields.

One June, seven or eight years ago, while shocking wheat in one of his father's fields near Sedgwick, Kansas, Earl Clark noticed two or three heads of wheat which were entirely different from the variety then grown

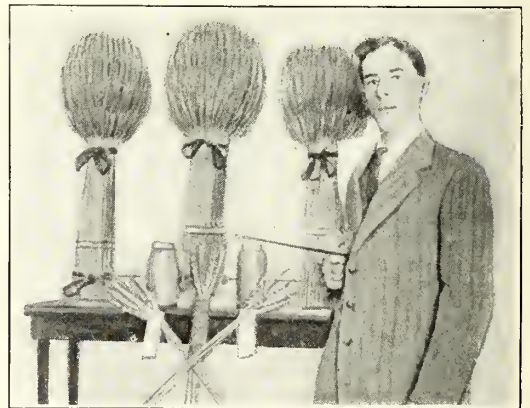

THE BLACK-HULL WHEAT AND ITS YOUNG DISCOVERER

all the Clark farms, and last autumn more than half a million acres of Kansas land were sown with it.

Experiments have shown that it produces, on an average, four more bushels to the acre than the famous Kanred wheat. The first four acres sown by the Clarks yielded ninety-two bushels to the acre.

Within the last few years, Clark's Black Hull has won large sums in prizes at wheat shows. It is said that at the last International Wheat Show at Wichita the only thing which prevented young Clark from taking the prize for the best wheat grown anywhere in the world was the fact that he overlooked entering it in the world class.

And now a bushel of this orphan wheat, which is fast replacing other varieties in every hard-wheat section, has gone to Armenia to aid in reseeding the country—once the greatest wheat-land of the Near East. Grain men say the ultimate result to be obtained by the hard-working Armenians from this one bushel of wheat probably will be of more permanent good to the country than anything else which might have been sent to it in the effort of saving its people to the world.

KEITH J. FANSHIER.

#### WHICH IS THE COOLEST HAT?

SOME interesting experiments have been recently carried out to show the heating and cooling effects of the various types of hats. Seven individuals were given hats each of a different pattern, and these were worn for

two hours outdoors on a blazing summer day. At the end of the time, the temperature inside each hat was taken, and with the following results.

In the case of a typical soldier's hat (cloth, and with a hard peak), the reading of the thermometer was no less than 98.6° F. With an ordinary cloth cap, the temperature was 94.1°. The hard derby hat gave a record of 92.3°, while that of the silk hat was 89.6°. This latter instance is interesting on account of the popular idea that a silk hat is the hottest of all headwear. The hard straw hat gave a temperature of 86°, showing a higher reading than the soft felt hat, which was considerably less, with a reading of only 79.7°. Coolest of all the hats was the soft white straw or Panama, which gave a reading of only 77.9°. That it

pays to keep a Panama well bleached is shown by the fact that one that was badly discolored with exposure gave a temperature three degrees higher than a new one that was very white.

S. LEONARD BASTIN.

#### A TRAVELING OUTFIT FOR SURVEYORS

AN unusual outfit is in use by the United States Coast and Geodetic Survey. As the work of this department is largely along the railroad rights of way, two motor-velocipedes, fitted with flanged wheels to run on the railroad-tracks, have been fitted up. One of



AN EASILY TRANSPORTED SURVEYING KIT

these cars carries the transit, the tripod being securely mounted upon the frame of the vehicle, and in using it, the operator stands in the space between the tracks.

In the second car, a rigid frame is bolted to the body of the vehicle and upon this is strapped an adding-machine for noting the readings of the level-rods. This is a valuable addition to the equipment of the field-parties. Flat trays or hand-barrows on each car are used for transporting the other instruments, tools, and personal belongings of the party.

A small gasolene engine under the frame supplies the motive power.

The cars are light in weight, with frames made of steel tubing, and are capable of traveling at a good speed with their load of instruments and passengers.

L. M. EDHOLM.



FOR VERY LITTLE FOLK

# A July Jingle

by  
Ellen  
Manly

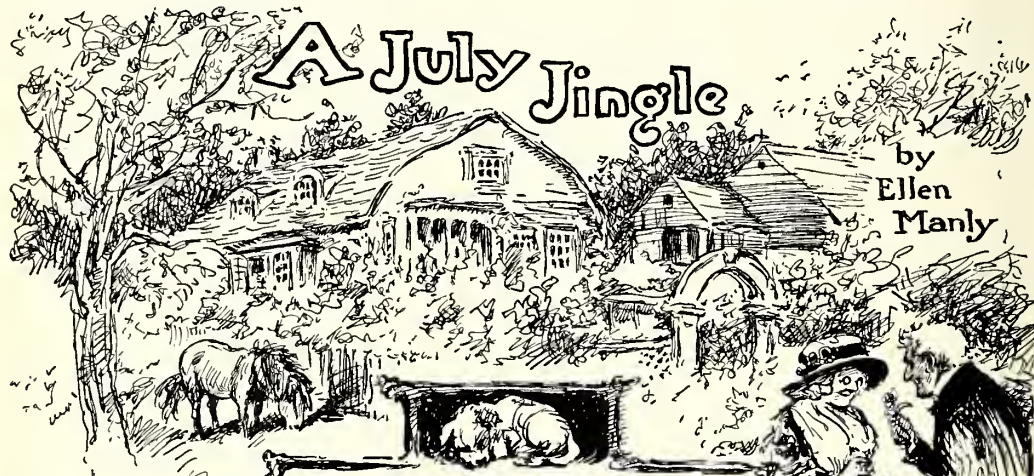

AN old white house, a garden,  
A big red barn behind,  
A grandma and a grand-dad,  
So very dear and kind.



And Doodles is the pony,  
And Toodles is the cat;  
And Poodles is the puppy-dog  
That dozes on the mat.



And Dolly is the dairymaid,  
And Molly is the cow;  
And Polly is the hen that lays  
Her eggs beneath the mow.



And Willy is the gardener,  
And Billy is the boy;  
And Tilly is the fat old cook  
Whose doughnuts are a joy.



And Lennie is my brother,  
And Benny Boy means *me*,  
And Jennie's little sister,  
And we're a busy three!





We ride the frisky pony;  
We pet and feed the cat;  
We frolic with the puppy-dog  
That dozes on the mat.

We drive the cow, with Billy,  
To pasture every day;  
We go with Grand-dad fishing;  
We tumble in the hay.

We hunt the eggs for Tilly;  
We watch the dairymaid;  
We plant our little gardens,  
With kind old Willy's aid.

We help to pick the cherries;  
We shell the peas for cook;  
We search the woods for berries;  
We paddle in the brook.

And Grand-dad says we 're farmers,  
It 's plain enough to see,  
And he could n't do without us—  
Little sister, Len, and me.

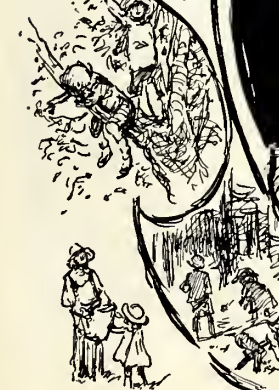



# ST. NICHOLAS LEAGUE

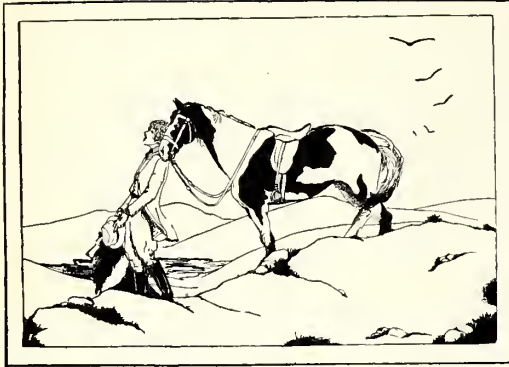

"VACATION 'S HERE." BY PHYLLIS REEVE, AGE 15. (SILVER BADGE)

STARTLING—or hackneyed—as the statement may sound, we have never observed that Young America seemed at a loss for ways and means of amusement; and this month's LEAGUE has proved to our satisfaction that American young folk are not likely at any early date to suffer for lack of recreation! The subject assigned for this July prose competition was "My Favorite Recreation," and such a list of "favorites" we have seldom seen! The responses came in shoals, and seemed to include every possible or imaginable

type of play, game, diversion, or idle-hour-ing. Swimming, diving, aqua-planing, and other water-stunts, together with canoeing and sailing, led the van naturally at this high-tide season for aquatic sports. And camping, of course, was extolled by countless enthusiasts, while miniature Izaak Waltons with their fishing-tackle also beckoned to the woods and streams. Tennis, baseball, and golf numbered their devotees by scores and hundreds. But the winter recruits followed close with their skating, skeeing and snow-shoeing, hockey, basket-ball, tobogganing, and other allurements of mid-February. Young Rough Riders and equestriennes on their broncos or thoroughbreds acclaimed riding as the king of sports, while the motorists, bikers, and hikers liked better to journey on wheels, gas-accelerated or self-propelled, or else on "Shanks' mare."

Nor must we overlook the numerous LEAGUE members who exalt the milder diversions of travel, sketching, gardening, and "butterflying," (one ardent philosopher of eleven earnestly recommends "meditation"! and another chooses as first of all recreations listening to Chopin's "Funeral March" and "Stabat Mater"). Among that still greater number, whose love of reading supplies a recreation of unfailing pleasure and benefit, were many whom even the most modest of Saints feels in duty bound to thank for adding to their enumeration of reading joys: "and especially reading St. NICHOLAS."

## PRIZE COMPETITION No. 268

(In making awards contributors' ages are considered)

**PROSE.** Gold Badge, **Louise D. Catherwood** (age 15), Pennsylvania. Silver Badges, **Agnes Mougan** (age 17), Massachusetts; **Eleanore Martin** (age 15), New York.

**VERSE.** Gold Badge, **Esther L. Cottingham** (age 16), Oregon. Silver Badges, **Helen Price** (age 12), Iowa; **Margaret Redington** (age 14), California; **Evelyn Crow** (age 15), Canada.

**DRAWINGS.** Gold Badge, **Margaret L. Westoby** (age 14), Canada. Silver Badges, **Elizabeth Moise** (age 13), Ohio; **Kenneth Rubrecht** (age 13), Minnesota; **Phyllis Reeve** (age 15), New York; **Melvin Roth** (age 13), California.

**PHOTOGRAPHS.** Gold Badges, **Eunice Cooke** (age 14), Massachusetts; **Francis Donaldson, Jr.** (age 13), Pennsylvania; **Leonard F. Bruml** (age 17), California. Silver Badges, **H. Lea Hudson** (age 15), New York; **Robert Hallas** (age 12), Germany; **Alice Miller** (age 14), New Jersey; **Kathryn L. Stienert** (age 14), Rhode Island; **Elizabeth Dargon** (age 13), South Carolina; **Harrison Blake** (age 10), Massachusetts; **Mary Fronheiser** (age 14), Pennsylvania.

**PUZZLE-MAKING.** Silver Badges, **George W. Chase** (age 13), Massachusetts; **Walter Gutmann** (age 13), New York.

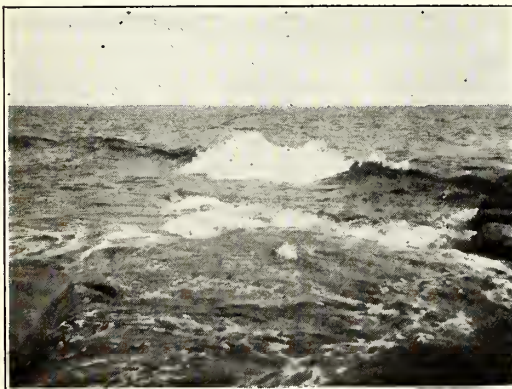

"TAKEN IN A SECOND." BY H. LEA HUDSON, AGE 15. (SILVER BADGE)



"TAKEN IN A SECOND" BY EUNICE COOKE, AGE 14. (GOLD BADGE. SILVER BADGE WON FEBRUARY, 1922)

"TAKEN IN A SECOND"



BY JAMES C. PERKINS, JR., AGE 16  
(HONOR MEMBER)



BY QUITA WOODWARD, AGE 13



BY ROBERT HALLAS, AGE 12  
(SILVER BADGE)

"TAKEN IN A SECOND"

MY FAVORITE RECREATION

BY RACHEL LOUISE CARSON (AGE 14)

(Honor Member)

THE call of the trail on that dewy May morning was too strong to withstand. The sun was barely an hour high when Pal and I set off for a day of our favorite sport with a lunch-box, a canteen, a note-book, and a camera. Your experienced woodsman will say that we were going birds'-nesting—in the most approved fashion.

Soon our trail turned aside into deeper woodland. It wound up a gently sloping hill, carpeted with fragrant pine-needles. It was our own discovery, Pal's and mine, and the fact gave us a thrill of exultation. It was the sort of place that awes you by its majestic silence, interrupted only by the rustling breeze and the distant tinkle of water.

Near at hand we heard the cheery "witchery, witchery," of the Maryland yellow-throat. For half an hour we trailed him, until we came out on a sunny slope. There in some low bushes we found the nest, containing four jewel-like eggs. To the little owner's consternation, we came close enough to snap a picture.

Countless discoveries made the day memorable: the bob-white's nest, tightly packed with eggs, the oriole's aerial cradle, the frame-work of sticks which the cuckoo calls a nest, and the lichen-covered home of the humming-bird.

Late in the afternoon a penetrating "Teacher! teacher! TEACHER!" reached our ears. An oven-bird! A careful search revealed his nest, a little round ball of grass, securely hidden on the ground.

The cool of approaching night settled. The wood-thrushes trilled their golden melody. The setting sun transformed the sky into a sea of blue and gold. A vesper-sparrow sang his evening lullaby. We turned slowly homeward, gloriously tired, gloriously happy!

FROM SEA TO SEA

BY MOLLY BEVAN (AGE 17)

(Honor Member)

I AM the wind of the westland,  
From the far Pacific shore,  
Where the Rockies rear their snowy peaks  
And the giant pine-trees roar;  
I sweep o'er the miles of the prairie,  
I ripple the golden wheat,  
And the eastern forests sing with joy  
At the touch of my flying feet.

I bear to the crowded cities of men  
The perfume of Western pine,  
I carry a spirit of dauntless hope  
From these Western hills of mine;  
Then on, over river, and lake, and field,  
Never by humans seen,  
I speed—till I greet with a sweet caress  
The land of *Evangeline*.

At last, to my journey's end I come;  
I sight the Atlantic's waves,  
And my mighty voice its welcome rings  
Through the sea-king's mystic caves;  
League after league—from sea to sea—  
I follow the trails of the sky,  
Then I bid farewell to the Eastern land  
And home to the West I fly.

MY FAVORITE RECREATION

BY LOUISE D. CATHERWOOD (AGE 15)

(Gold Badge. Silver Badge won August, 1921)

ON the shores of a lake in Maine is a camp—a very small camp, it is true, with only a few tents—in the heart of the big pine forest, whose gigantic limbs stretch forth as if in loving protection of the little tents below.

I think the most delightful of all the things we did there was the once-a-week picnic-supper.



We all took canoes, and, after piling them with baskets full of the most delicious food, paddled down the lake about two miles to a little island, where we spread our supper on the bed of pine-needles under the trees.

After supper we all gathered around the camp-fire and took turns at telling stories, while looking at the quiet lake now all rosy-red from the reflection of the setting sun. Far in the distance rose the majestic mountain-peaks, slowly becoming quite purple as the shadows of evening fitted down upon them.

After a while we packed our canoes again and started toward home. Before long the first evening stars peeped down at us and the moon rose over the hills shedding its soft light all over the lake.

It was all so silent, so very silent, away out there! The only sound to be heard was the soft *drip, drip* of our paddles as they were dipped in and out of the water. Nobody spoke; the silence was too beautiful to interrupt.

After awhile, however, we all drew closer together, and to the accompaniment of one of the girls who had a guitar, began to sing some of the good old camp-songs. As we drifted along thus, the warning bugle from our camp echoed across the silent lake and reluctantly we paddled home.



"VACATION 'S HERE." BY WORTHEN BRADLEY, AGE 17. (HONOR MEMBER)

### MY FAVORITE RECREATION

BY KATRINA E. HINCKS (AGE 13)

(Honor Member)

Is there any need to name it? What can be more delightful, on a hot July day when the sky is a cloudless blue, than to slip into a bathing-suit, and, with a laughing crowd of friends, to dash across the beach and plunge into the surf? The water is very blue, with tiny white-caps, as we splash gaily out to the white float and scramble up, dripping and panting, and the fun begins.

There is a splash and a shriek as we begin pushing each other off into the clear water, and soon heads are bobbing up on all sides of the raft as we dive (and splash!) like veritable mermaids.

"Follow the leader!" cries Jean, and, poised on the edge of the spring-board, raises her gleaming arms for a dive. See! She is off, in that most graceful of dives, the swan, and we eagerly follow, with varying success. In a moment we are racing for the other float, some thirty yards distant. Jean, the leader, is well ahead, but



"TAKEN IN A SECOND." BY EVELYN REINHOLD, AGE 14

others are gaining fast. We are half-way between, and still she leads! Arms flash out of the blue water and Jean looks back for a moment to see how close we are. Now another girl has passed her, and in three strokes has touched the raft! We all climb up, and sit on the float for a few minutes to get our breath, and then begin our revels all over again.

Much has been written of the "old swimmin'-hole" in the country, but to me, the ocean is always a playmate and provides the best place for my favorite recreation.

### FROM SEA TO SEA

BY MARGARET B. OLESON (AGE 16)

(Honor Member)

At times when gray and fragrant dusk comes down  
And silence broods throughout the little town,  
Fair foreign countries beckon unto me,  
And I would travel far, from sea to sea,  
To lands where ruined castles crumble slow away,  
Part of the pageant of a bygone day,  
And sail the seas unto a sunny shore,  
Where relics call back ancient Rome once more;  
To lands where shifting deserts burning lie  
Beneath the blueness of an Eastern sky.

So do I dream of wond'rous countries fair,  
Until the velvet darkness falls, and then  
As home lights flame across the little town  
I love it best, and am content again.

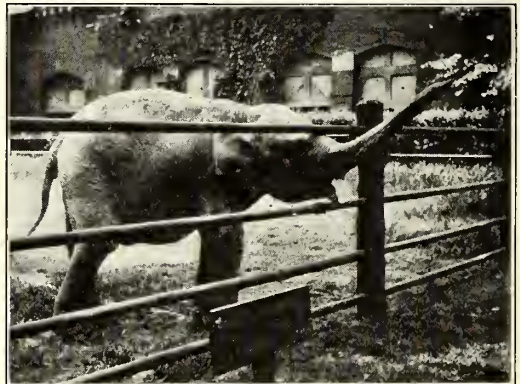

"TAKEN IN A SECOND." BY FRANCIS DONALDSON, JR., AGE 13  
(GOLD BADGE. SILVER BADGE WON SEPTEMBER, 1921)



BY MELVIN ROTH, AGE 13. (SILVER BADGE)

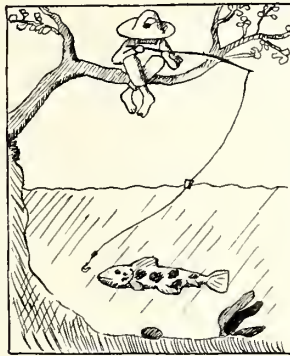

BY KENNETH RUBRECHT, AGE 13 (SILVER BADGE)

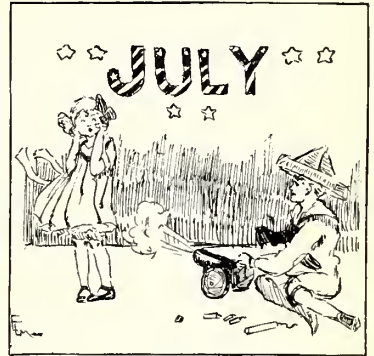

BY ELIZABETH MOISE, AGE 13 (SILVER BADGE)

"VACATION 'S HERE"

MY FAVORITE RECREATION

BY AGNES MOUGAN (AGE 17)  
(Silver Badge)

A GRACEFUL dive into the glistening waters of the bay, and your head comes bobbing up near the shining board, about four feet long and three feet wide, which floats in the water behind the motor-boat and is tied to it by two stout cords. A few strokes, and your hand grasps the board. It immediately sinks under your weight; but not for long, for the engine gives a *chug—chug chug*, and the boat starts moving slowly at first, but soon faster. The rope fastened to the board tightens. It rises out of the water and grows taut. Slowly you pull yourself onto the board, grasping the rope reins in dripping hands. Now the knees gain the crosspiece across the back—now one foot—then the other! The forward part of the board comes almost vertically out of the water. You are standing!

The wind whistles by, whipping stray hairs about your face. The speed of the boat increases and

the plane cuts the water, leaving a trail of swirling, foaming waves which rush about your feet. Farther and farther away from the shore, out into the sapphire clearness of the bay, past the ledges, past the little island with one lonely tree, off into the very center of the inlet, you are drawn. The fresh east wind fills the lungs.

Oh, the exhilaration, the thrill and the joy of it! Vague wishes rush through the mind—just to ride over the white-capped waves forever, to skim past countless little islands, a Nereid and messenger of Neptune.

Of all the sports, I think there is nothing quite equal to aquaplaning. To me it reigns supreme.

HER FAVORITE RECREATION

BY ZYRA BRODY (AGE 12)  
(Silver Badge)

"I WON'T play!" and a door slammed. Grace Murray shook her head slowly. There was nothing to do about it. Madeline Armstrong almost always kept her word.



BY ALICE MILLER, AGE 14 (SILVER BADGE)



BY KATHRYN L. STEINERT, AGE 14 (SILVER BADGE)



BY ELIZABETH DARGON, AGE 13 (SILVER BADGE)

"TAKEN IN A SECOND"





"VACATION 'S HERE." BY KATHLEEN MURRAY, AGE 13

The trouble was due to the fact that Madeline, after a severe illness, had lost her love for basket-ball and refused to play. She could n't exactly explain the feeling, but—she would n't play; for as she said, "What 's the good of playing badly?"

Grace, her particular friend at Westmore Hall, told the others.

"Marjorie Findley will have to be right guard until she comes back. She (Madeline) was one of the best players, too."

"Suppose she does n't come back?" said Jean.

"We won't think of that," replied Grace, cheerfully. "I'm sure Madeline *will* come back."

A month later, a week before the biggest game of the season, Grace said: "Here we are, losing some of the games, tying others, or winning by one or two. I wish something would happen to *make* Madeline play."

Grace's wish was granted by a peculiar turn of affairs. Marjorie Findley broke her ankle, and her substitute was ill, so all the girls went to Madeline and asked her to play; but it was probably Grace who persuaded her, "for the honor of the school."

A few days' practice soon made her all right for the oncoming game.

It was really Madeline who made Westmore win by her brilliant playing. It was she who made the score 20 to 12.

The next day, Madeline said to Grace: "I never realized until yesterday that I wanted to play basket-ball again. I know what the feeling was that I had before. It was just plain laziness. All I wanted to do was read, sleep, and eat; but hereafter I intend to make basket-ball my favorite recreation."

### FROM SEA TO SEA

BY ESTHER L. COTTINGHAM (AGE 16)

(Gold Badge. Silver Badge won May, 1920)

FROM sea to sea the treasure-ships of yore  
Sailed over many oceans, wild and vast;  
With white and glitt'ring sails and flag-topped  
mast,

Each was a wonder never seen before  
By natives living on some foreign shore,

To which these ships were driv'n. They often  
cast

Their anchors in some Eastern port, then  
passed,

With treasures, seaward, to be seen no more.

Some, going out to sea, were tempest tossed,

Unable to withstand the driving gale,

And somewhere in the Seven Seas were lost;

While others in calm weather, with full sail,

Rode into their home ports in majesty,

Rich from their wanderings from sea to sea.

### MY FAVORITE RECREATION

BY GWENDOLYN HOFFMAN (AGE 14)

OH, the joy of living when the golden summer days again are here! The wonderful thrill of the open fields where nature seems to call me to take part in a joyful game! This is tennis.

The ball comes flying toward me over the net. I leap and run, and toss it lightly back. The rivalry is keen. Then, when I miss a ball, I



BY HARRISON BLAKE, AGE 10  
(SILVER BADGE)

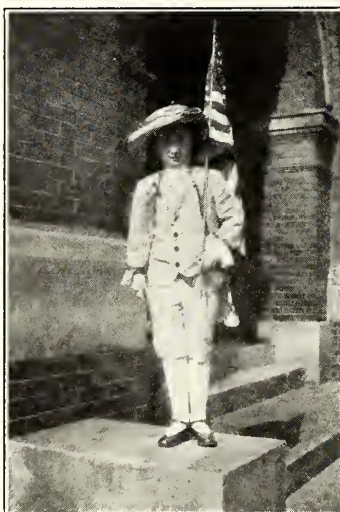

BY ROSALIA POLLAK, AGE 12



BY BETTY LEE, AGE 11

"TAKEN IN A SECOND"

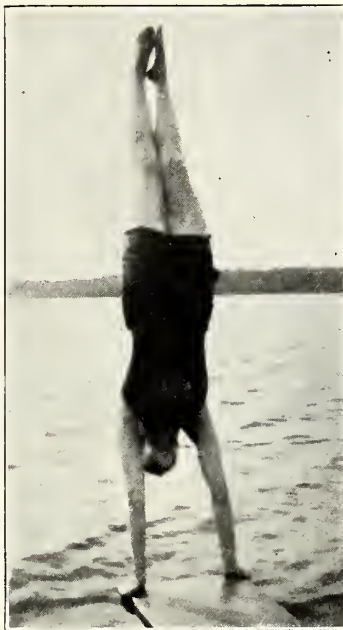

BY MARTHA SHERMAN TABER, AGE 14

BY MARY FRONHEISER, AGE 14  
(SILVER BADGE)BY LEONARD F. BRUML, AGE 17. (GOLD  
BADGE. SILVER BADGE WON JANUARY, 1922)

## "TAKEN IN A SECOND"

strive to make it up. I rush and run and hit each flying ball. All my muscles tingle with a brilliant play. The score now favors me. I think I see the end—myself the winner. Then we rest, and I get ready to play the last set.

Now we are at it again. My cheeks are flushed. My heart beats high with hope. The game is drawing toward its close. I serve the last ball, throwing myself forward with a last attempt to make a point. The game has ended.

Now the air is filled with shouts, with shrieks and cheers. It does n't matter whether I have won or not. For even if I have not won, the game has done me good. I will do better, and hope to win some other time. It is a royal game!

I've found the nicest game for girls and boys. It makes me feel and love the great outdoors. The summer days are full of happiness for me. I have made my choice—tennis is my favorite recreation.

## FROM SEA TO SEA

BY EVELYN CRAW (AGE 15)

*(Silver Badge)*

SUNLIT slopes of softest green, little lambs at play;  
Silvery streams that softly sing, in songs both sad  
and gay.

Purple hills with peaks of white, stars that shine  
out in the night;

Voice of west wind, strong and free, from sea to  
sea, from sea to sea.

Rush and strife of city life, for money, power, and  
fame;

Men that bravely work and fight, and play a  
losing game;

Mothers smiling through their pain; children  
playing in the rain;

Babies sleeping, pink and wee, from sea to sea,  
from sea to sea.

God of the open prairies, God of the valleys and  
hills,  
God of the great deep forests, of the rivers and  
laughing rills,  
Loving Father of Mankind, this our prayer of  
heart and mind,  
"Keep Thy children near to Thee, from sea to  
sea, from sea to sea!"

## MY FAVORITE RECREATION

BY MARIAN GRANT (AGE 15)

*(Silver Badge)*

It was the second day of the beef round-up. As we gathered for work we found an empty pasture where we had left the cattle gathered the day before. Rustlers' work, we all knew. As more of the riders came, Tex explained, "Our little friends came and pulled up the corner of the little pasture, and the little horse-tracks went back up the cañon."

The boss, Lloyd, sent us out two by two to drive the gulches, pockets, and cañons leading into the big cañon, leaving two to hold the cattle already found.

"Bob, have you ever been up that cañon? She's a long one." Then, as Bob shook his head, "You'd better drive it. Marian," Lloyd turned to me, "are you equal to going with him?"

"Certainly," said I.

Frank and Helen took the next cañon, Sam had the one opposite ours, Jesse and Zelma went up Fire Cañon, while Lloyd and Willard rode to the head of the big cañon.

Going to the head of our cañon, Bob and I drove it, getting a small bunch of cattle. Helen and Frank soon came, saying they had followed their cañon to Medicine Bow. "If that's the case," said Bob, "Marian and I were where we could look down on Casper."



Soon Lloyd came charging out of the brush, followed by Sam and Willard. They had no cattle, so we went toward the main bunch, joined by Jesse and Zelma with the few they had.

Here the beef and unbranded calves were cut out and taken to some branding corrals, where we branded the calves, and turned the beef into the beef-pasture. Then, as it was late in the afternoon, we started for home.

Riding? Yes, you have it! My favorite recreation and the greatest sport in the world.



"TAKEN IN A SECOND." BY MERYL STATELER, AGE 14

### MY FAVORITE RECREATION

AS IMAGINED BY CARYL DUKE (AGE 11)

NOW, as you must know, my favorite occupation was hunting. One day, when about fifteen years old, my father took me on a hunting-trip to the Adirondacks. At night we stopped and made our camp.

The next day we went to hunt, my father having seen a deer the night before. My father and the other men went ahead, and suddenly I heard shots. I ran ahead, but stumbled over something and fell. To my surprise, I saw a cat's scratch on my hand, and, as I looked around, I saw a little baby wildcat! I called to the men, but they said I would have to come to them. I went there, and, much to my surprise, saw a big wildcat lying dead. "Now come and see what I have found," I said. They followed and saw the baby. We wondered why it did not run away, but one of the men said, "It has a broken leg!"

We went back to camp and packed up to go home. "What do you expect to do with that cat in an apartment?" said Daddy.

"Keep it in the parlor," said I.

We took it home and bound its leg, and when it was better it was so tame it would follow me around like a dog. Finally, it got so big and I begged so hard to keep it that we bought a house.

Every day I used to let it run, and it always came back. One day, however, it disappeared. We went to look for it, but we could not find it. We offered a reward, but nobody brought him back.

One day in the Zoo, I was standing close to a cage, when I felt something pat my back. I

looked around, and there was my old friend, the wildcat! And thus were two old pals reunited.

### MY FAVORITE RECREATION

BY ELEANORE MARTIN (AGE 15)

(Silver Badge)

WHY should reading be my favorite recreation? There are reasons innumerable.

Behind those paper, cloth, or leather doors, lie magic worlds, open to me whenever I order them brought by my faithful slaves, eyes, brain and imagination.

Behind those doors lie Egypt with her pyramids, Spain with her Alhambra, Japan with her temples, all the countries of the globe with their attractions. Behind them lie majestic forests, bustling cities, mighty rivers, tiny hamlets, and the broad blue sea.

Behind those doors stand *Lorna Doone*, *Lad and Bruce*, the *Brinker* family, *Florence Dombey*, *Ivanhoe*, and all the other friends, dear to millions through the medium of the printed page.

The comrades in books can always be depended on. When I want them they come immediately and cheerfully at my command. When I am tired of them I may send them away and they do not linger or grumble at my rudeness.

They amuse me, they thrill me, they give me information. If I like them, I need never be separated from them; if I dislike them, I need never see them again. I can always find happiness in books, the priceless treasures and the rightful heritage of every one.

### SPECIAL MENTION

A list of those whose work would have been used had space permitted:

PROSE	Charlotte Neumeister	DRAWINGS
Hayes Robbins, Jr.		Constance V.
Shirley White		Carrier
Charlotte Dickinson		Laura F. Sacket
Margaret Durick	VERSE	Ann Baillio
Rauha Lauhinainen	Margaret Redington	Emelyn Wyse
J. Frances Bischoff	Mary F. Twichell	Bertha Schmidt
Phyllis Dale	Helen Price	Edith Pierce
Elizabeth Evans	Margaret Mack	Isabelle Brumby
Hughes	Prang	Ruth H. Dimick
Jane Custis Bradley	Robert McNamara	Ellen L. Carpenter
Katharine R. Chase	Maistry MacCracken	Gertrude Walker
Virginia Schoolfield	Elizabeth	Bentley B. Stegner
Marine Leap	Naumburg	Elise Durrin
Dorothy Kaufman	Doris E. Conner	Virginia Stratton
Catharine Richey	Froncie Wood	Lorna Dunn
Florence Warburton	Catherine A. Crook	Alexander Marino
Mary Arndt	Ellen Leffingwell	Betty Carrington
M. Willard Messler	Henry A. Myers	Donald Dodge
Virginia E. Jobson	Florence E. Jackson	Ruth Whitten
Elizabeth Tracey	Mary H. Wilde	George B. Hiester
Oril Brown	Josephine Munroe	PHOTOGRAPHS
Philip Sherburne	Robert Benn, Jr.	E. K. Graves
Margaret P.	Augusta Bonzogni	Mary Thurston
Coleman	Marion Turner	Margaret Reynolds
Polly Winslow	Elizabeth G. Zalesky	Andrew K. Peters
Elsie Brodkey	Ada A. Ireton	Regina Dunn
Minnie Pfeferberg	Ruth Temple	Barbara Jack
Artine McPheters	Julia F.	Elisabeth Perkins
Elizabeth W.	Vander Veer	Muriel Robinson
Kingsbury	Lincoln Fay	Margaret Ullom
Edward L. Carroll	Robinson	Ellis Saint
Florence C. Roeber	Stewart North	Gladys Wright
Harriet F. Marrack	Margaret Cross	Gertrude Marshall
Barbara Simison	Caroline Harris	Dorothy Eshleman
Margaret Hill	Patricia Snyder	Betty Alden
Collins	Mabel Gibberd	Brainard
Dorothy Estabrook	Katherine P.	Bill Hayden
Madelyn Kennedy	Goringe	Thomas R. Talbot
Marian H. Churchhill	Virginia P.	Edith R. Seymour
Alice E. Dumper	Broomell	Laura Dupee
Wilhelmina Rankin	Richard Angell	Jeannette A. Nebel
Rosalie Story	Betty Baillio	Edith Barrett
Martha	Mary C. Gain	Christine S. Miller
Brandenburg	Grace A. Petersen	
	Helen L. Whitehouse	

## ROLL OF HONOR

A list of those whose contributions were deserving of high praise:

## PROSE

Eleanor C. Ashley  
Elizabeth S. Cadle  
Rose Pollack  
Lucy Hutchins  
Rose Merryweather  
Elizabeth B. Clarke  
Ray Ellis  
Hilda Bonacker  
Shirley Fern  
Hilda Bell Howes  
Susan N. Everhard  
Paul Wertheimer  
Penelope Borden  
Anne P. D. Lester  
Maryon Elloise  
Martin  
Martha McCowen  
Leah Gordon  
Frances Tuck  
Jean Lawyer  
Lois E. King  
Ruth Clark  
Ruth Chrest  
Annis Doane  
Alice Seney  
Dorothy Smith  
Norma Paul Ruedi  
Marjorie Aline  
Wallace  
Grace Harper  
Glover  
Helen Gyurak  
Charles E. Wilkins  
Helen Stickney  
Marion Thompson  
Hope M. Hamilton  
B. F. Vail Morford  
Elisabeth Gruener  
Emilie H. Rosenfeld  
Elizabeth Gardiner

## VERSE

Muriel Andrews  
Dorothy Lavenson  
Anna Bruen  
Mary C. Reynolds  
Lois Young  
Regina Wiley  
Elinor N. Cobb  
Sophie Cohen  
Marion T. Burnett  
Sylvia Hahn  
Charlotte E.  
Farquhar  
Rachel Jackson  
Joseph Morsman  
Shirley Wachler  
Elizabeth Crosby  
Mary Koch  
Alice Hooper  
Edna Marks  
Lucy M. Thornton  
Elizabeth  
Hardaway  
Catherine V.  
Sullivan  
Dorothy Bladin  
Margaret Harkness  
Jeanette A.  
Thurston

## Maxine Wiley

Lucy Sanborn  
Eleanor Ellis

## DRAWINGS

Marian Dunlop  
Phyllis V. Dohm  
Yvonne Twining  
Margaret Howell  
Elizabeth Boyle  
Virginia Snedeker  
Margaret L. Milne  
George C. Wiggins  
Ione Drake

## PHOTOGRAPHS

Mary T. Shepard  
Abbie L. Bosworth  
Edith Heidingsfeld  
Mary Youngman  
Betty Fowler  
Frances Kimball  
J. B. White  
Anna Weld  
Rose Monosoff  
Marion Rothschild  
Mabelle Hunt  
Justine Foote



"A HEADING FOR JULY." BY MARGARET L. WESTOBY, AGE 14. (GOLD BADGE. SILVER BADGE WON JUNE, 1921)

Anne Gleaves  
Lillian Weiss  
Harriet Carlton  
John Bogart  
Nancy Crocker  
Muriel Doe  
Susannah R.  
Deacon  
Christina P. Fish  
Jack Milne  
Esther E. Turner  
Helen Collins  
Spencer Dormetzer  
Orale Williams  
Esther M. Blake  
John A. Donovan  
Dorothy Dayton  
Betty Ridden  
Willis Anna Tyson  
Elizabeth Flinn  
Constance Turner  
Barbara Taylor  
Frances Parke  
Jessie Hull  
Evelyn Cotton

Donald C. Weeks  
John H. Rowe, Jr.  
Ruth B. Lyman  
Dorothy Horton

## PUZZLES

Charles Eugene  
Smith  
Rosalie Bailey  
E. L. Hourwich  
Elizabeth Howser  
Florence Goddard  
Edith Witt  
Evelyn Helfat  
Catherine Simpson  
Dorothy  
McGuinness  
Janice Yard  
Leslie Friend  
Marian R. Ballin  
Celestine McCarver  
D. Monroe  
Mary Beals  
Eleanor Vivian  
Ruth E. Pease

## WHAT THE LEAGUE IS

THE ST. NICHOLAS LEAGUE is an organization of the readers of the ST. NICHOLAS MAGAZINE.

THE LEAGUE motto is "Live to learn and learn to live."

THE LEAGUE emblem is the "Stars and Stripes." THE LEAGUE membership button bears the LEAGUE name and emblem.

THE ST. NICHOLAS LEAGUE organized in November, 1899, became immediately popular with earnest and enlightened young folks, and now is widely recognized as one of the great artistic educational factors in the life of American boys and girls.

THE ST. NICHOLAS LEAGUE awards gold and silver badges each month for the best *original* poems, stories, drawings, photographs, puzzles, and puzzle answers.

## PRIZE COMPETITION, No. 272

**Competition No. 272** will close August 1. All contributions intended for it must be mailed on or before that date. Prize announcements will be made and the selected contributions published in ST. NICHOLAS for November. Badges sent one month later.

**Verse.** To contain not more than twenty-four lines. Subject, "November Joys," or "The Gloaming."

**Prose.** Essay or story of not more than three hundred words. Subject, "An Autumn Adventure," or "The Test."

**Photograph.** Any size, mounted or unmounted; no blue prints or negatives. Young photographers need not develop and print their pictures themselves. Subject, "A Holiday Photograph."

**Drawing.** India ink, very black writing-ink, or wash. Subject, "My Favorite Subject," or "A Heading for November."

**Puzzle.** Must be accompanied by answer in full.

**Puzzle Answers.** Best and neatest complete set of answers to puzzles in this issue of ST. NICHOLAS. Must be addressed to THE RIDDLE-BOX.

No unused contribution can be returned *unless it is accompanied by a self-addressed and stamped envelop of proper size to hold the manuscript or picture.*

## RULES

ANY reader of ST. NICHOLAS, whether a subscriber or not, is entitled to LEAGUE membership, and upon application a League badge and leaflet will be sent free. No League member who has reached the age of eighteen years may compete.

Every contribution, of whatever kind, **must bear the name, age, and address of the sender and be indorsed as "original" by parent, teacher, or guardian, who must be convinced beyond doubt—and must state in writing—that the contribution is not copied, but wholly the work and idea of the sender.**

If prose, the number of words should also be added. These notes must not be on a separate sheet, but *on the contribution itself*—if manuscript, on the upper margin; if a picture, *on the margin or back.* Write *in ink on one side of the paper only.* A contributor may send but one contribution a month—not one of each kind, but one only; this, however, does not include "competitions" in the advertising pages or "Answers to Puzzles."

Address: **The St. Nicholas League,**  
The Century Co.  
353 Fourth Avenue, New York.

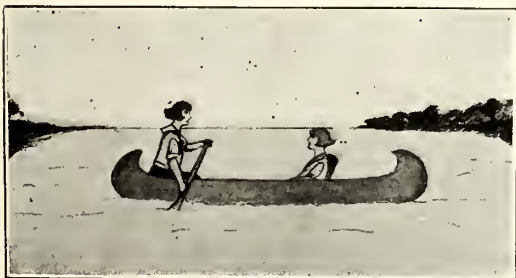

"A HEADING FOR JULY." BY HELEN HODGE, AGE 15



# THE LETTER-BOX

NAPLES, ITALY.

DEAR ST. NICHOLAS: We spent twenty days on Mt. Vesuvius, and these are the three excursions we made: one to Mt. Somma, one to the "Atrio del Cavallo," and the other to the crater of Mt. Vesuvius.

When we went to Mt. Somma, we started from the hotel at eight o'clock, and carried our luncheon. The walk was beautiful, all green trees and beautiful flowers. We passed a precipice many yards deep and quite dangerous. When we arrived at the spring, we had lunch and drank some of the clear water. On our way back we met a snake. We arrived at the hotel at three o'clock.

When we went to the Atrio del Cavallo, we started at one o'clock, P.M., and had a long walk on the lava. When we arrived there we saw a lot of little mounds with steam coming out of them. The mounds were all covered with sulphur, and we got a lot of it to bring home. Then we sat down to rest, and about four o'clock we came to the hotel.

The day we went up Vesuvius, we started about nine in the morning, and went part of the way in a tram, and then we changed to a funicular and went up the steep summit. We walked about ten minutes around the crater to an open space, from which we could look in. The cone was throwing up a lot of stones and flames. Afterward we came down on foot. It was very slippery on the sand, but it was great fun.

MIMI CASANO (AGE 12).

NEW ROCHELLE, N. Y.

DEAREST ST. NICHOLAS: I wish to thank you for two things. First of all for helping our class out in finding a poem or verse for selections. Last winter, our teacher could not find anything about Christmas. So I thought of you and brought you to school and the teacher selected "Christmas Wishes," by Myrtle A. Aldrich, in the December number.

Secondly, I wish to thank you for giving me so much pleasure from your most interesting stories. I love THE LETTER-BOX, and the LEAGUE. THE WATCH TOWER I find most interesting, and every single thing that is in you from cover to cover.

Your loving reader,  
EDYTHE T. WALLACH (AGE 12).

SALISBURY, ENGLAND.

DEAR ST. NICHOLAS: I have taken you for three years and hope to take you for many more. I am an American, but have only been to the States once, eight years ago. I have lived a lot in the south of Spain and am at school in England now. There are nearly three hundred girls here. I live in Southampton, and it is very interesting watching all the huge liners go in and out.

I love all the stories, I don't know which are my favorites. There is always a clamor here when you arrive. I wish you could come weekly instead of monthly. I was so pleased when you arrived yesterday, as I have been lying down and not allowed to move because I have cut my knee. I should have been very bored without you.

Wishing you all good luck and many readers,

Yours sincerely,  
MARGARET BEVAN (AGE 13).

PALO ALTO, CALIF.

DEAR ST. NICHOLAS: Although I have only taken you since Christmas, I have learned to love you very much.

It takes a short time to read you from cover to cover, and after I have done that, I wait impatiently for the next copy.

Among the stories I like the best are "The Turner Twins," "The Hill of Adventure," and "The Blue Envelop."

Palo Alto is a very pretty little town with wide-spreading oak trees, situated near the Leland Stanford University.

It is only about an hour's ride to San Francisco; and is in the Santa Clara Valley, which is at present a perfectly beautiful sight, as all the fruit-trees are in bloom. This is the greatest fruit-raising valley in the world, I am told, and people who have seen the cherry-blossom season in Japan, say it does not compare with that of our Santa Clara Valley.

Last February, Mother took my sister and me to the Yosemite. Although the falls were not as full as they are in spring and early summer, it was beautiful, and especially wonderful to us, who, being Californians, had never seen snow before.

I had my first toboggan ride, and enjoyed it immensely.

Wishing you the best of luck, I remain your devoted reader,

BETSY BEATTY (AGE 12).

LIMA, PERU.

DEAR ST. NICHOLAS: I think that you are perfectly ripping, and I don't know what I could do without you.

I came across you quite by accident. One day, I was hunting in my friend's library when I happened to see you. I read you from cover to cover and simply loved you. What was my delight to hear that my friend still subscribed to you. She gave me your address, and so I got you as soon as possible.

When one likes reading as I do and has such a delightful magazine as you to read, she ought to be more glad than *Pollyanna*,—and I am!

Loads of good wishes,  
WINIFRED ASHTON (AGE 11).

VANCOUVER, B. C., CANADA.

DEAR ST. NICHOLAS: You are the very nicest magazine imaginable, in my estimation. I have taken you for seven years, and even now, though I'm nineteen years old, I still thoroughly enjoy you, and since I have no brothers or sisters younger (or older) than myself to take you, I still continue to do so.

I love reading about the girls' camps; it makes me long to go to one of them, they sound so attractive. Each month I try solving the puzzles, and I just revel in all the stories, especially the serials.

Each one seems more enticing than the last; that, as you will understand, is another reason why I hate to give you up.

Daddy took you when he was a boy, and I have four volumes of you bound.

Wishing you lasting success,  
Ever your loving reader,  
PHYLLIS C. THOMPSON.

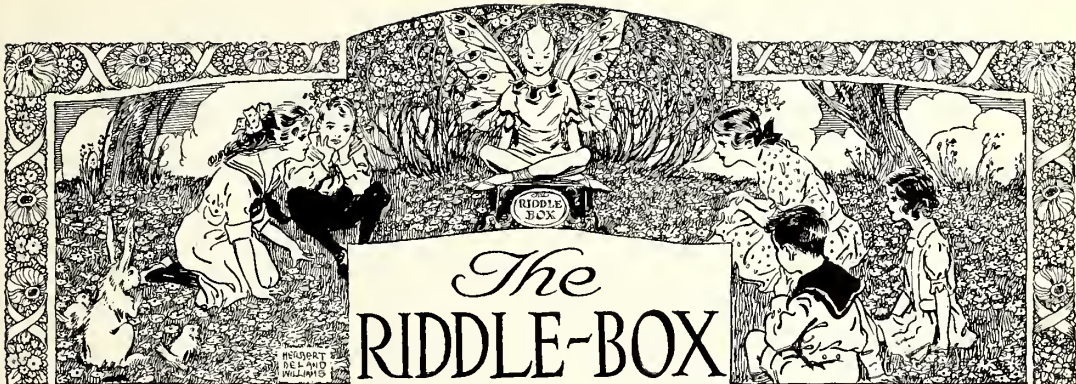

**ANSWERS TO PUZZLES IN THE JUNE NUMBER**

**DIAGONAL.** Burbank. Cross-words: 1. Boneset. 2. Lucerne. 3. Verbena. 4. Bulbous. 5. Heal-all. 6. Anemone. 7. Sea-pink.

**TRIPLE BEHEADING AND TRIPLE CURTAILINGS.** Longfellow. 1. Bel-low-ing. 2. Rep-rod-uce. 3. Con-man-der. 4. Men-age-rie. 5. Con-fir-med. 6. Com-pet-ent. 7. Rec-all-ing. 8. Un-will-ing. 9. Opp-one-nts. 10. Scr-awl-ing.

**PRIMAL ACROSTIC.** Primals, Columbus; finals, E. Cross-words: 1. Cue. 2. One. 3. Lie. 4. Use. 5. Mae. 6. Bee. 7. Ute. 8. See.

**PICTURED POEMS.** Lowell. 1. The Fountain. 2. The Rose. 3. The Falcon. 4. A Glance Behind the Curtain. 5. The Sower. 6. The Oak. 7. The Pioneer.

**PI.** Has queen-like June cast jewels on the earth,  
And turned them into flowers and brilliant birds?  
O whence have come these gem-like charms whose birth  
Brings eloquence and joy too grand for words!

**CONNECTED DIAMONDS.** I. 1. E. 2. Ell. 3. Elder. 4. Lee. 5. R. II. 1. E. 2. Pal. 3. Eater. 4. Let. 5. R. III. 1. R. 2. Eat. 3. Rapid. 4. Tin. 5. D. IV. 1. R. 2. Tot. 3. Roved. 4. Tea. 5. D.

**NUMERICAL ENIGMA.** "A great heart has no room for the memory of wrong."—Cross-word ENIGMA. Hyacinth.

**WORD-SQUARES.** I. 1. Cast. 2. Area. 3. Seem. 4. Tame. II. 1. Trip. 2. Rode. 3. Idea. 4. Peat. III. 1. Cape. 2. Afar. 3. Pain. 4. Erne.

**CHARADE.** Dan-de-li-on; dandelion.

**NOVEL ZIGZAG.** Zigzag, Theodore Roosevelt. From 1 to 5, eland; 6 to 9, lion; 10 to 16, leopard; 17 to 21, okapi; 22 to 28, giraffe; 29 to 33, hyena; 34 to 43, rhinoceros; 44 to 53, wildebeest; 54 to 58, genet. Cross-words: 1. Tasteless. 2. Shortcake. 3. Sheltered. 4. Ignoramus. 5. Blunderer. 6. Portfolio. 7. Slanderer. 8. Pedometer. 9. Slaughter. 10. Afterglow. 11. Mastodons. 12. Paymaster. 13. Reddening. 14. Curvature. 15. Deepening. 16. Illuminated. 17. Transfers.

**TO OUR PUZZLERS:** To be acknowledged in the magazine, answers must be mailed not later than JULY 27 and should be addressed to ST. NICHOLAS RIDDLE-BOX, care of THE CENTURY CO., 353 Fourth Avenue, New York City, N. Y. Solvers wishing to compete for prizes must comply with the LEAGUE rules (see page 1005) and give answers *in full*, following the plan of those printed above.

ANSWER TO ALL THE PUZZLES IN THE APRIL NUMBER were duly received from Miriam J. Stewart—Helen McIver—John Nolan—H. and H. S. Dormitzer.

ANSWERS TO PUZZLES IN THE APRIL NUMBER were duly received from Gertrude Wagner, 9—Eliza Smith, 9—John F. Davis, 9—Vera A. Skillman, 9—June M. Hinman, 9—Rosalind Howe, 9—Gertrude R. Jasper, 7—Rosalie Bailey, 7—Elizabeth Faddis, 7—"Livonia," 6—Blackie, 5—Carlen S. Messler, 5—Mary A. Hurd, 5—Marian Levin, 5—Madeleine Thibeaux, 5—Elizabeth Tong, 5—Gertrude Hill, 4—St. N. Club, 4—Frederick Olmsted, 4—M. Willard Messler, 4—Kingsley Kahler, 3—Elsie Koniger, 3—Benj. F. Brown, 3d, 3—Ann Sommerich, 3—Helen McBride, 2—Josephine Wertheim, 2. One puzzle, E. Norton—R. J. Bell—L. Van Camp—S. Butcher—D. M. Green—E. C. Sperry—M. Leach—M. Jeffords—K. W. Jefferys—J. Riddle—K. Higbee—H. Krumwiede—E. Hartt—N. Barto.

**A FRENCH ACROSTIC**

(Silver Badge, St. NICHOLAS LEAGUE Competition)

* 28	15	46	63	40	54	CROSS-WORDS: 1. To
* 27	5	26	18	52		slander. 2. A kind of
* 68	8	12	.	.	16	footstool. 3. Zealous.
* .	45	11	.	6	47	4. A harrowing event.
* 29	22	35	41	.	32	5. Equipment for a horse.
* .	64	48	59	.	.	6. Deference. 7. To in-
* 1	.	.	7	55	.	struct systematically. 8.
* .	60	65	43	36	30	Self-conceit. 9. To
* 13	39	10	.	49	.	handcuff. 10. Having
* 51	31	61	21	.	.	the same shape or design.
* .	3	67	58	38	.	11. Pertaining to seeds.
* .	.	33	17	.	57	12. A place for preparing
* 23	53	.	.	4	.	food. 13. Pertaining to
* 24	.	50	.	.	66	morals. 14. A play-
* .	.	56	9	2	.	house. 15. An error in
* .	20	25	.	19	.	writing or printing. 16.
* 34	.	37	.	.	42	To marry. 17. A stand
* 62	44	.	.	14	.	for public speaking. 18.

Standing out.

When these words have been rightly guessed, the initial letters (indicated by stars) will spell the name of a famous book. The letters indicated by the figures from 1 to 5 spell the name of the author of the book; and the letters indicated by the figures from 6 to 14, from 15 to 19, from 20 to 26,

from 27 to 32, from 33 to 41, from 42 to 47, from 48 to 55, and from 56 to 68 each name a character in the book.

WALTER GUTMANN (age 13).

**DIAMOND**

1. In charming. 2. The cry of an animal. 3. A windy time. 4. A unit. 5. In charming. NANCY H. ALLEN (age 10), *League Member*.

**OBLIQUE PUZZLE**

IN solving, follow the accompanying diagram, though the puzzle has more cross-words.

CROSS-WORDS: I. In sloop. 2. A Biblical character. 3. Walked with measured tread. 4. A measure. 5. To put off. 6. A kind of fortification. 7. Storms. 8. Cosy retreats. 9. Plump. 10. More certain. 11. An article of faith. 12. A supply of anything to afford relief from time to time. 13. The claw of a predaceous bird. 14. To warble in the manner of Swiss mountaineers. 15. Unhackneyed. 16. In sloop. ELIZABETH FREELAND (age 12) *League Member*.



**NOVEL ACROSTIC**

All the words described contain the same number of letters. When rightly guessed and written one below another, the primals will spell a famous general, and the third row will spell a place always associated with him.

CROSS-WORDS: 1. Freshly. 2. Fright. 3. Part of a flower. 4. A musical drama. 5. Extensive. 6. A feminine name. 7. Health-giving air. 8. A running knot.

JOSEPH G. RIDDLE (age 12), *League Member*.

**A Missing Syllable**



A common little word of two syllables may be prefixed to each of the nine objects shown. What are the nine new words?

**CROSS-WORD ENIGMA**

My first is in John, but not in Adams;  
 My second, in Robert, but not in Lee;  
 My third is in Thomas, but not in Jefferson;  
 My fourth is in Henry, but not in Clay;  
 My fifth is in Theodore, but not in Roosevelt;  
 My sixth is in Millard, but not in Fillmore;  
 My seventh is in Franklin, but not in Pierce;  
 My eighth is in Chester, but not in Arthur;  
 My ninth is in Rutherford, but not in Hayes;  
 My tenth is in Charles, but not in Hughes;  
 My eleventh is in Patrick, but not in Henry.

My whole signed the Declaration of Independence.

KENWARD BABCOCK (age 10), *League Member*.

**DOUBLE ACROSTIC**

My primals, reading downward, name a famous war; and my finals, reading upward, name a very conspicuous figure in that war.

CROSS-WORDS (of equal length): 1. To unite after separation. 2. An inhabitant of a cold country. 3. An expensive fabric. 4. Excursion. 5. A kind of tree. 6. An art gallery in Florence. 7. A ditch. 8. Foolish persons. 9. A Canadian city. 10. Bigoted.

FLORENCE MADDOCK (age 14), *League Member*.

**CHARADE**

My first is never genuine,  
 My last is always plain;  
 My whole is not so far away,—  
 A lake, but not in Maine.

M. DAVIS (age 16), *League Member*.

**ADDITIONS AND SUBTRACTIONS**

1. Germ - m + and - d + ium = ?
2. Nail - il + stamp - amp + ur + tie - e + um = ?
3. Din - in + ant - t + delta - ta + ion = ?
4. Pie - ie + ride - de + me - e + rout - ut + se = ?
5. Geneva - eva + tide - de + and - d = ?
6. Arm - ar + rig - r + no + not - ot + eat - a + te = ?
7. Date - te + harp - arp + light - ght + a = ?
8. Colt - t + use - se + arm - ar + bide - de + ne = ?
9. Mark - rk + idea - a + name - ame + have - ve + ir = ?
10. Hot - t + ill - i + cry - cr + horn - rn + crock - cro = ?
11. Tan - t + ate - at + mop - p + net - t = ?
12. Cap - ca + arm - rm + news - ew + yes - es = ?

ELIZABETH STEWART (age 12), *League Member*.

**A SUMMER KING'S MOVE PUZZLE**

(Silver Badge, ST. NICHOLAS LEAGUE Competition)

1	2	3	4	5	6	7
I	L	S	N	I	O	A
8	9	10	11	12	13	14
I	A	G	C	B	T	I
15	16	17	18	19	20	21
T	N	A	R	G	N	T
22	23	24	25	26	27	28
R	G	G	G	B	A	H
29	30	31	32	33	34	35
G	A	N	F	N	I	H
36	37	38	39	40	41	42
N	V	I	O	I	S	I
43	44	45	46	47	48	49
I	L	E	W	R	G	N

Begin at a certain square and move to an adjoining square (as in the king's move in chess) until each square has been entered once. When the moves have been made correctly, the names of seven summer sports may be spelled out. The path from one letter to another is continuous.

GEORGE W. CHASE (age 13).

*They are not Keds unless  
the name Keds is on the shoe*



*One of the Keds models  
that all the fellows want.  
Heavy soles, sturdy re-  
inforcements, ankle  
patch — corrugated  
smooth or suction soles.*

## Shoes like the paws of a boy's best pal

**C**AN you run faster than your dog? Can you jump as high as a dog half your size? Examine your dog's paws some day. They are soft and springy. That's one of the reasons why he is so agile.

With a pair of Keds your feet become as much as possible like the paws of a dog.

Keds are built with

- thick rubber soles, pliable, springy, protecting.
- tough canvas tops, light and cool.
- reinforcements where the wear comes.

With Keds like these you will find you can run faster, walk

farther, and do better in your sports and games.

There are high Keds and low Keds and brown Keds and white Keds.

You can get the kind you wish at your dealer's. If he doesn't have them, he can get them for you.

### *Look for the name Keds*

But remember, Keds are made only by the United States Rubber Company, the largest and oldest rubber organization in the world. If the name Keds isn't on the shoes, they aren't real Keds.

*Booklet, "Camping," sent free if you write to Dept. D-4, 1790 Broadway, New York.*

**United States Rubber Company**



*The world's standard summer shoe. For tennis, canoeing, sailing, and general outdoor wear. High and low models for boys and girls too.*

# Keds

Trademark Reg. U. S. Pat. Off.



*Keds were originated and are made only by the United States Rubber Company.  
The name Keds is on every pair. It is your guarantee of quality and value.*





"Come On!  
Ice Wagon"

You Can Ride Rings Around the  
Other Fellows When You're On  
One of Those Speedy

## Dayton Bicycles

YOU will get the "jump" on them every time—and hold the lead too—so little effort is needed to keep the Dayton spinning along.

That's why champion racers ride it—and why the big hope of most boys is to have one of these fast, smooth-running bikes.

Every single unit of the Dayton is made in our own immense factory—the surest way of producing a bicycle that will prove up 100% in service.

If that's the sort of bicycle you want,—speedy, enduring, good looking, easy riding—get a Dayton. Be the best mounted boy in your town.

Our new booklet, "How to Choose a Bicycle," will tell you many things you ought to know. Write for your copy now. Use the coupon.

Cycle Division

The Davis Sewing  
Machine Company  
Dayton, Ohio



# Ingersoll

For Summer Time  
And All the Time



All Ingersoll watches are good timekeepers. Sturdy, reasonable, reliable, good looking, they carry a sound guarantee.

You need not worry about loss, theft nor breakage. The cost of a new Ingersoll is so small, comparatively. Twelve models, including Radiolites. See dealers' displays.

INGERSOLL WATCH CO., Inc.  
New York San Francisco  
Chicago

Yankee  
\$1.50



**KOKOMO**

**SKATES**

Are Young America's First Choice

Ask your dealer for them.

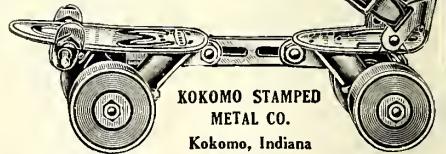

KOKOMO STAMPED  
METAL CO.  
Kokomo, Indiana

**GIRLS**

**GIANT**

Will blow  
over 4 feet  
in circumference



**BOYS**

**BALLOON**

15¢ By mail  
prepaid  
Stamps accepted



Statue of Liberty printed on each Balloon

Dept. S

603 Third Ave. New York

---  
The Davis Sewing Machine Co. ---  
No. 27, 110 to Choose a Bicycle, and the  
Name  
Address  
Age  
---  
FILE IN—CUT OUT—MAIL TODAY  
Dayton, Ohio

Zolfo Springs, Fla.  
March 5, 1920

Ang  
2/1  
No  
Dear

“Saved my baby”

Zolfo Springs, Fla.,  
March 5, 1920.

Anglo-American Drug Co.,  
215 Fulton St.,  
New York.

Dear Sirs:

I am using Mrs. Winslow's Syrup. It saved my baby from dying of colic, which she had for three months.

Someone advised me to get Mrs. Winslow's Syrup and I did.

Yours truly,

(Name on request)

Thousands of mothers have found that the safe, pleasant way to keep baby healthy and happy is to use

# MRS. WINSLOW'S SYRUP

*The Infants' and Children's Regulator*

It quickly overcomes diarrhoea, colic, flatulency, constipation and teething troubles. Write for booklet of letters from mothers.

*At All Druggists*

ANGLO-AMERICAN DRUG CO., 215-217 Fulton St., N. Y.

General Selling Agents: Harold F. Ritchie & Co., Inc.,  
New York, Toronto, London, Sydney

The complete, open formula appears on every label.  
GUARANTEED NON-NARCOTIC, NON-ALCOHOLIC







**Auto-Wheel Advantages make this Coaster the Fastest of 'Em All**

For fast, smooth riding you cannot beat the Auto-Wheel Coaster or Auto-Wheel Convertible Roadster. Each has self-contained roller bearings — which are thoroughly and completely greased at the factory. These bearings make your coaster the fastest of 'em all. The disc wheels are the latest type and have a special autotype hub cap, on which the word "Auto" is embossed on the end. Reinforced rear axles and new front hound and support make for additional Auto-Wheel safety and comfort. Either disc or spoke wheels fit all models of Coasters and Convertible Roadsters.

Plan to get your Auto-Wheel Coaster or Convertible Roadster now. Send for free dime bank — and ask for the free six months' subscription to the "Auto-Wheel Spokesman" — the magazine for live boys.

Just send the names of three coaster dealers in your town, telling which one sells the Auto-Wheel. Then you will get your free dime bank and free magazine.

AUTO-WHEEL COASTER COMPANY, 195 Schenck St., North Tonawanda, N. Y.

**ROCHE'S** HERBAL **EMBROCATION**  
RELIEVES SAFELY AND PROMPTLY

**CROUP**  
OR  
**WHOOPIING COUGH**

Also wonderfully effective  
in Bronchitis, Lumbago  
and Rheumatism.

All druggists or  
**W. EDWARDS & SON**      **E. FOUGERA & CO.**  
London, England      90-92 Beekman St. N. Y.

**Factory to Rider**

Saves \$10 to \$25 on the Ranger Bicycle you select. You can have your choice of 44 Styles, colors and sizes. Delivered free on approval, express prepaid, for 30 DAYS' FREE TRIAL.

**12 Months to Pay** If desired. Possession and use at once on our liberal year to pay plan. Parents of ten advance first payment.

**Tires** Best quality, at factory prices, express prepaid. Lamps, wheels and equipment, low prices. Send No Money, do business direct with makers

**Mead Cycle Company**  
Dept. A 15 Chicago

Write today for free Ranger Catalog, factory prices and marvelous easy payment terms



**Moore Push-Pins**  
*Glass Heads - Steel Points*  
**Moore Push-less Hangers**  
To hang up things  
*Ask your dealer to show them*

Sold Everywhere **10¢** per packet  
**Moore Push-Pin Co.**  
Wayne Junction Philadelphia

*What the Newspapers  
are Saying About  
W. F. Alder's*

**“The Isle of Vanishing Men”:**

“THIS time it is the out-of-the-way island of New Guinea to which the author takes us in a most delightful book of his experiences. The island is inhabited by cannibals, and while he wished to go there to study the natives, an unexpected shipwreck made it impossible for him to get away. He lived right in the village with the cannibals and learned much about them that has never been told before. Every page of the book is full of interesting and incredible things.”—*St. Louis Globe-Democrat.*

“A very unusual travel book of a little-known portion of the earth.”—*Cincinnati Commercial Tribune.*

“A crisp, brisk record of interesting experiences in a strange land. Its traveler's tales are set down without literary trimming, and in a fashion that will make a lot of folks glad that Brother Alder's journey to 'the interior' did not end in the interior of one of the cannibals that still clutter that isolated part of the earth.”—*Worcester Telegram.*

**“The Isle of Vanishing Men”**

*is published by*

**THE CENTURY CO., 353 Fourth Avenue  
NEW YORK CITY**

*And is sold at all bookstores*

*The price is \$2.00*



*Every sport is even more sport with a*

# KODAK

Your album filled with pictures of good times will be the book you like the best. Whether it's riding or fishing, tramping or camping, Kodak as you go.

There's a Kodak dealer right around the corner. Ask him to show you how easy picture-making is the Kodak way.

*Autographic Kodaks \$6.50 up—Brownies \$2.00 up*

Eastman Kodak Co., Rochester, N. Y. *The Kodak City*





Photographs from St. Nicholas League

# ST. NICHOLAS Never Takes a Vacation

**D**ID you ever stop to think that your favorite magazine never takes any time off? Since it was started forty-nine years ago it has been coming off the press every month, without an interruption. In good years and bad years ST. NICHOLAS has always made its appearance.

When you leave for camp, or other vacation grounds, see to it that ST. NICHOLAS comes along. You will find time between swimming, hiking, baseball, and other sports to read a bit, and for such a time there's nothing better than good old St. Nick!

Perhaps you are among that unfortunate group that does not see ST. NICHOLAS every month in the year. Your copy may come from a friend,

or the library, or a newsdealer. All are very good sources, but not to be depended upon for each and every number — particularly during vacation time.

So to be sure you'll not miss any of "The Mystery at Number Six," or "The Inca Emerald," or "The Turner Twins," to say nothing of such short stories as "The Pinch-Quitter," by William T. Tilden, 2nd., the world's tennis champion, or "Tilbury Wood" and "Dwarf Hildebrand," by Bernard Marshall, or "In the Wake of the Hurricane," by Charles Tenney Jackson, or "The Key," by Beth B. Gilchrist, you had better fill out the blank at the bottom of this advertisement and send it *at once*.

THE CENTURY CO. {Concord, N. H., or  
353 Fourth Avenue, New York City.

S.N. 7-22

Gentlemen: Please find enclosed \$4, for which send ST. NICHOLAS for one year, beginning with the August number, to

Name.....

Street.....

City..... State.....



Only one-fifth of the buildings owned by the Bell System are shown in this picture.

## A Telephone City

Above is an imaginary city, made by grouping together *one-fifth* of the buildings owned by the Bell System, and used in telephone service. Picture to yourself a city *five times* as great and you will have an idea of the amount of real estate owned by the Bell System throughout the country.

If all these buildings were grouped together, they would make a business community with 400 more buildings than the total number of office buildings in New York City, as classified by the Department of Taxes and Assessments.

Next to its investment in modern telephone equipment, the largest investment

of the Bell System is in its 1,600 modern buildings, with a value of \$144,000,000. Ranging in size from twenty-seven stories down to one-story, they are used principally as executive offices, central offices, storehouses and garages. The modern construction of most of the buildings is indicated by the fact that the investment in buildings is now over three times what it was ten years ago.

Every building owned by the Bell System must be so constructed and so situated as to serve with efficiency the telephone public in each locality, and to be a sound investment for future requirements.

“ BELL SYSTEM ”

AMERICAN TELEPHONE AND TELEGRAPH COMPANY  
AND ASSOCIATED COMPANIES

*One Policy, One System, Universal Service, and all directed toward Better Service*





# ST. NICHOLAS STAMP PAGE

CONDUCTED BY SAMUEL R. SIMMONS

## NEW ISSUES

THE past month has brought us its usual quota of new issues. But many of the newer things are merely differences in color, or water-mark—differences that would not show in a picture. However, there are still a few things which we can show which we know will interest our readers. The first is a stamp from Lithuania. This



reaches us through the courtesy of an anonymous reader of STAMP PAGE who lives in Paterson, New Jersey. It is really a very beautiful stamp. It is evidently for airplane service, as indicated by three airplanes in full flight. The planes are of a soft brown color, the clouds white, the sky blue; a very effective combination. The frame of the stamp is brown and blue. At the top is the word Lithuania; in the lower corners the value, 2 auks. There is also the word, or words ORO

Pastas; the first three letters are much larger in size than the last six. We imagine this means air post. We know our readers will join us in thanks to this unknown friend and fellow-collector of Paterson. Here we would like to interpolate a word to all who send us such stamps where the wording is in a foreign language: Please send us

with the stamp all possible information about the new issue, and especially a translation of all the inscriptions. Our readers are full of curiosity about the new stamps; they want to know what the words mean. And so do we, ourselves. ¶We have also another airplane stamp. This one is entirely in blue, and comes to us from French Morocco. The design is so large and clear that it needs no description from us. ¶There is a new issue from Antigua, that country whose stamps are so popular. Why they should be so, we do not know. Perhaps, because its stamps rank well with the other British West Indies and its name brings it alphabetically the first in our albums. This series runs through many values of the same design. The head of King George shows promi-

nently, but the little scene in the lower right corner is not very clear. The foreground appears to be water, the background a high hill with buildings on it; and in the intermediate distance is a tall tree, or perhaps plant, at the bottom of which are what look to be six large leaves. ¶Samoa sends us a series which shows a native hut, while on the left is the English flag. ¶The last stamp to be illustrated is the 15-millimes of the new Egypt series. The color is blue and the design very striking.

\$32,000

ONE of the first things which the new collector learns is that stamps have a commercial value. Most boys and girls see stamps only as affixed to letters which come to their homes. They see the envelop opened, its contents reviewed, and then envelop and stamp thrown away casually. It is therefore in the nature of a surprise to them to realize that stamps—even canceled stamps—cost money. And the collector also learns how greatly the value of these little bits of paper varies. He loves to pore over the pages of his album, catalogue in hand, and see what value is attached to each of his stamps—to find which is the highest priced stamp he owns. And he always looks at it so fondly as he turns over the pages. It may not be the prettiest design, nor the most perfect copy; but it is the stamp that is worth the most. From this it is but a short and natural step to study how high the values run on the pages of his catalogue, and curiosity is aroused by those stamps opposite to which no price whatever is attached. What are these worth? So it is not at all surprising that "What is the most valuable stamp?" is one of the questions most frequently asked us. As a companion to this is the question, "Who owns the largest collection in the world?" Until recently an answer to this last has been easy. The collection of Count Ferrari, an Austrian living in Paris, has always been regarded as the largest collection—a collection far surpassing all others in size, at least. But the question as to the rarest stamp was not so easy to answer. There were several contestants. The first issue of Mauritius, the one called the "post-office issue" because of the inscription at the left-hand side, has always been rare. Moreover, it has been popular as well. Scarcity, coupled with demand, is what makes for high prices. For years these two stamps have sold at top-notch prices—around six thousand dollars, perhaps. But it has been equally well known that there were rarer stamps than this first issue of Mauritius. While of these there are possibly thirty or more copies known, there are others far rarer. Indeed, there are several stamps so rare that only one copy is known to exist. What are these worth? No one could tell. Being but one copy, there were never any sales. But now that Count Ferrari's collection is being broken up, sold in a series of public auctions held in Paris, we are learning the market value of these rarities. This wonderful sale has attracted to Paris stamp-collectors from all over the world. Probably about a dozen Americans attended the sale

(Concluded on second page following)

# THE ST. NICHOLAS STAMP DIRECTORY

is really a list of reliable Stamp Dealers. These people have studied stamps for years, perhaps they helped your father and mother when they first started their stamp collections. *St. Nicholas* knows that these dealers are trustworthy. When writing to them be sure to give your full name and address, and as reference the name of your parent, or teacher, or employer, whose permission must be obtained first. It is well also to mention *St. Nicholas Magazine*. Remember, we are always glad to assist you, so write to us for any information that will help you solve your stamp problems.



## TRIANGLE

Scarce FIUME (like illustration), also 50 other different stamps, China ship set, large \$1.00 U. S. revenue; millimetre scale, ruler and perforation gauge. Bargain lists and 50 to 60% approvals with every order. **FENNEL STAMP CO., Dept. S., Fullerton Bldg., St. Louis, Mo.**

All For  
**9c**

**STAMPS** 50 different Jamaica, Venezuela, etc., only 7c; 100 all different, 10c; 1000 all different, \$2.50; 100 different U. S. 25c; 1000 hinges, 10c; 50% approvals with every order. List Free. I buy stamps.

L. B. COVER Dept. F. Longmont, Colo.

**BARGAINS EACH SET 5 CENTS**  
4 Iceland; 8 Finland; 20 Sweden; 8 Honduras; 8 Costa Rica; 10 Russia; 8 Dutch Indies; 4 Siam. Lists of 7000 low-priced stamps free.

CHAMBERS STAMP CO., 111 G NASSAU STREET, NEW YORK CITY

**FREE** Packet of desirable stamps, exceptional quality to approval applicants furnishing satisfactory references.

H. C. ARGENTBRIGHT, Box 352, Staunton, Va.

**STAMPS—20 VARIETIES, UNUSED, FREE** to all sending for our approval sheets at 50% discount. Postage 2 cents. Mention *St. Nicholas*. QUAKER STAMP CO., TOLEDO, OHIO.

**FREE** 2 GERMAN AEROPLANE STAMPS to approval applicants. Reference required. J. R. NICHOLS, 2322 Loring Pl., New York City.

**DANDY PACKET STAMPS** free for name, address 3 collectors, 2c postage, with 50% apprs. 125 dif. U. S. inc. high values, 50c. U. T. K. STAMP CO., UTICA, N. Y.

**Stamps Free** Fine set War Stamps, Surcharged, Unused, Pictures, British, French Col's with Big Price List, 2c postage. MIDLAND STAMP CO., Toronto, Canada.

**FOREIGN STAMPS FREE**—Big Variety Packet Foreign Stamps from all over the World. 2c postage. GRAY STAMP CO., Station E., Toronto, Canada.

**25** Gold Coast, Newfoundland, India, etc.. **FREE** with trial approval sheets. 500 different stamps 90c; 1000 all different \$2.25. Hinges 10c per M. F. J. STANTON, Norwich, N. Y.

**WORLD'S LARGEST** Wholesale and Retail Catalogue of Postage Stamps now ready. 128 pages. Single stamps, sets, packets, albums, mixtures, supplies, etc. **Price 10 cents. Worth \$5 to you. Send 10 cents today.** **Bargain Sets** We offer these great bargains at low prices. No two stamps alike in any set. All fine. 50 Africa 24c; 15 Arg. Rep. 11c; 50 Asia 17c; 35 Austria 10c; 35 Bavaria 20c; 10 Brazil 5c; 100 Br. Col's 20c; 25 Bulgaria 25c; 20 Chile 11c; 10 China 7c; 50 Cuba 49c; 10 Czecho's 12c; 10 Egypt 7c; 7 Iceland 20c; 50 Italy 19c; 40 Japan 7c; 8 Liberia 25c; 17 Mexico 10c; 13 Nyassa 45c; 10 Paraguay 10c; 25 Persia 25c; 6 Reunion 5c; 20 Russia 10c; 7 Siam 15c; 10 Straits 7c; 20 Sweden 11c; 100 U. S. 20c; 10 Uruguay 8c; 50 French Col's 34c; 50 Portuguese Col's 35c. Following wonderful collections guaranteed to satisfy or your money back: 1000 varieties \$2.90; 1500 varieties \$5.45; 2000 varieties \$8.90. Postage extra. Remit in stamps or money order. We buy stamps. MARKS STAMP CO., Dep't N, TORONTO, CANADA.

## STAMP BARGAINS

30 all diff. Asia 25c (Packet No. 54); 100 all diff. Asia \$1.00 (Packet No. 22); 100 diff. from 50 different Countries 25c (packet No. 68).

*You can't beat these bargains*

**SCOTT STAMP & COIN CO.**

33 West 44th St.

NEW YORK CITY



**65c for 8c.** Abyssinian stamp, Guatemala Parrot stamp, Packet 30 varieties British Colonies, cat. 65c. Packet Hinges. Large mm. scale, perf. gauge and wmk. detector. Price list and finest 50% approvals all for 8c. **WE BUY STAMPS.**

**ALLEN SEARS, Inc.**

Dept. S, Suite 508 Kemper Bldg., Kansas City, Missouri.



## 158 Genuine Foreign Stamps

Mexico War issues, Venezuela, Salvador and India Service, Guatemala, China, etc. **Only 10c** Finest Approval Sheets 50 to 60%. Agents Wanted. Big 72-page Lists Free. We buy Stamps. Estab. 29 yrs. **Hussman Stamp Co., Dept. 52, St. Louis, Mo.**

**QUICK SERVICE!** When you want stamps you want 'em quick. And I have just the kind you want; clean, well arranged up to date approval selections at 50% disc; with extra discounts for prompt returns. The general collector will be delighted. Try them and you will say "How does he do it?"

D. M. WARD, 608 Buchanan St., Gary, Ind.

P. S. 3 Aguinaldo Philippine Stamps free to approval applicants.

**SNAPS** 150 different foreign, 18c. 60 different U. S. including \$1 and \$2 revenues, for 12c. With each order we give free our pamphlet which tells "How to Make a Collection Properly." **QUEEN CITY STAMP AND COIN CO., Room 32, 604 Race St., Cincinnati, O.**

Stamps 50 all diff., Africa, Brazil, Peru, Cuba, Mexico, Ceylon, Java, etc., and Album, 10c. 1000 Finely Mixed, 40c. 50 diff. U. S., 25c. 1000 hinges, 10c. Agts. wtd., 50%. List Free. I buy stamps. C. Stegman, 5940 Cote Brillante Ave., St. Louis, Mo.



(Continued on next page)



**STAMPS**—(Continued from preceding page)

**STAMPS** 105 China, etc., stamp dictionary, list 3000 bargains, 2c. Album (500 pictures), 3c. **BULLARD & Co., Sta. A, Boston.**

**FREE** List of sets and approvals. **HUB POSTAGE STAMP Co., Inc., 345 Washington Street, Boston, Mass.**

**FREE** 7 beautiful French Colonials, to approval applicants. **FRANK HADLEY, Box 73, Plainfield, N. J.**

**200** diff. Stamps 18c; 100, 9c. 20 Persia 20c. Hinges 1000, 12c. Lists Free. **MICHAELS, 5602 Prairie, Chicago.**

**ZANZIBAR.** 3 different, 6c. **A. C. DOUGLAS, A. S. D. A., LUCAN, ONT.**

**FREE** Packet of fine stamps for names and addresses 2 live collectors, and 2 cents postage. **HIAWATHA STAMP SHOP, Syracuse, N. Y.**

**4 different Morocco, Cat. 32c, for 14c**  
**R. H. A. GREEN, 821 Main St., Evanston, Ill.**

**FREE 10 CHINESE STAMPS** to approval applicants enclosing postage.  
**A. EMERY, Dept. N., 567 Oakwood Ave., Toronto, Canada**

**FREE** 10 Scandinavian, millimetre scale, gauge, book, lists, etc., to all sending 10c for 57 diff. Siam, Ceylon, Guatemala, etc., 200 diff. 25c., 300 diff. 75c., 100 diff. U. S. 25c.  
**HAWKEYE STAMP Co., Cedar Rapids, 49, Iowa.**

**FRENCH COLONIES FREE**—Set Used and Unused Pictures, Wild Animals, Native Chiefs, Scenery and big bargain List. 2c postage. **EMPIRE STAMP Co., Toronto, Canada.**

**ST. NICHOLAS STAMP PAGE**

(Concluded from second preceding page)

recently held. And they saw sold for the record price of thirty-two thousand dollars one of the world's greatest stamp rarities. If our readers will take their catalogue and turn to British Guiana and look at the illustration for number thirteen, they will see a picture of this very rare stamp—the one-cent value of the issue. There is a foot-note saying that only one copy of this stamp is known. We know that our readers will be delighted to know that this celebrated stamp is now owned by an American. Before the sale, there was much speculation as to who would be the purchaser of the stamp. The general opinion was that it would find a resting-place in the collection of King George of England. And it is more than probable that he was one of the bidders through some representative. But the stamp comes to America, and at the highest price ever paid for a stamp. This is not all. It is reported that the purchaser bought many other things at the sale, and that his bill totaled upward of a hundred thousand dollars.

**FREE** 20 Diff. British Colonies for a request for my  $\frac{1}{2}$ ,  $\frac{1}{3}$ , 1 and 2c approvals also the higher priced stamps at 50% Disct. with extra Discts. for prompt returns.  
**CHARLES T. EGNER, 1335 Pike St., Philadelphia, Pa.**

**100 VARIETIES AUSTRIA AND BIG LISTS. 14c**  
**JOHN M. LONG, 67 Public Sq., Watertown, N. Y.**

Stamp Saving is a fascinating game. It teaches one to be observing. You must study the design, the coloring, the perforations, the cancellations, the value, the age and the amount of each new stamp.

Join the **ST. NICHOLAS STAMP CLUB** and enjoy its benefits with them. We will send you a membership blank, if you ask for it.

*Press Comments On*

**MYSTIC ISLES OF THE SOUTH SEAS**

By **FREDERICK O'BRIEN**

Author of "White Shadows in the South Seas"

**O**BRIEN'S book is not mere description, and his glamor is not the old glamor of picturesque romance. Consciously and unconsciously, but more often consciously, he presents in this easy-flowing, almost too discursive narrative of life with a nature people a new defence of the primitive in man and an attack upon industrial civilization. . . . This is a story by one of those rare men who really try to understand their environment, and who, when they go abroad, live the life of which they write."—*New York Evening Post.*

"Frederick O'Brien, incomparable story teller, has spread a magic carpet of adventure and romance, and we who come daily into this murky atmosphere of soot and grime may clasp its sunshine for our very own. . . . It is the chronicle of a clear-seeing, sympathetic, thoroughly human American male through whose veins runs a love for things odd, colorful, mysterious."—*Chicago Daily News.*

"A joy to read, and re-read. Every now and then the thumb digs into the margin to mark a gem to be used in tempting others."—*Oakland Tribune.*

["Mystic Isles of the South Seas" is published by The Century Co., 353 Fourth Avenue, New York City, and is sold at all bookstores for \$5.00]

# CAN YOU AFFORD—

To pass up this attractive offer?

If you are fond of sports—and we know you are—it follows that you enjoy good live sport stories, and articles dealing with the famous figures in sport.

## *Here is the Offer:*

The five volumes of the **Charles E. Van Loan Memorial Edition**, containing forty-nine stories in all, written about baseball, boxing, golf, racing and the movies, together with a year's subscription to **THE AMERICAN GOLFER**, **THE SPORT PICTORIAL**, can be had for Ten Dollars. Where can you duplicate such an offer in sport reading? Every one of the Van Loan stories contains a bunch of hearty laughs. **THE AMERICAN GOLFER**, **THE SPORT PICTORIAL**, is edited by **Grantland Rice** and appears every other Saturday. You don't need any introduction to Mr. Rice. He is the leading writer on sport subjects in the country beyond doubt, and his personal articles in this magazine are well worth the above price.

*Send in your order without further delay. The coupon below is intended for your convenience.*

CENTURION PUBLISHERS, INC.  
353 Fourth Avenue, New York City

Enclosed find \$10.00, for which send me **THE AMERICAN GOLFER**, **THE SPORT PICTORIAL**, for one year (26 issues); and the 5-volume Memorial Edition, boxed and express paid.

*Magazines and books  
may, if desired, be sent  
to separate addresses.*

NAME .....

ADDRESS .....

*Postage in Canada, 50 cents; foreign countries, \$1.00.*



It's Ten to One You Are  
Healthier Than You Think

# OUTWITTING OUR NERVES

By

JACKSON, M.D., and SALISBURY

THE most cheerful, the most readable, the most helpful, the most successful, the most enthusiastically endorsed book on better health that has been published in years. Doctors are prescribing it. The reviewing press has given columns to both the authoritative subject matter and the delightful style of the book.

It does not indulge in vain platitudes about worry and will power; it shows the real reason for worry and the blues. There are chapters on the Subconscious Mind, The Real Trouble, The Way Out, That Tired Feeling, Dietary Taboos, The Bugaboo of Constipation, Insomnia, Woman's Handicap, and others equally vital. Some of these chapters will revolutionize the habits of a life-time.

A great part of all disease is functional: organic disease is far less common. Functional diseases are curable and it is the great discovery of psycho-analysis that they are often removed by just understanding their nature and gaining a right mental attitude. "Outwitting Our Nerves" is an invaluable aid to the achievement of such an attitude. It reveals how many kinds of disease can result from mistaken mental attitudes; tells how not to be sick when there is no real reason for staying sick; how to face your difficulties, know what they are and how to deal with them; how to live, fully, bravely, happily.

33rd thousand. Price \$2.50

## Press Comments:

**The New York Evening Post:** There is not a shimmer of a doubt but that one-half the people in the United States could read this volume with profit.

**Boston Transcript:** It is a particularly practical book, certain of being useful to large numbers of people.

**The New York Times** (In a page review by Van Buren Thorne, M.D.): Contains explanations of the Freudian principles in their simplest form and is therefore invaluable to those whose knowledge of them is vague or confused.

**Pittsburgh Dispatch:** It is written in an admirable style, never ponderous, but as bright as the cheerful message it brings.

**Boston Herald:** Not just another book about a new kind of treatment, not just another psychic book, but a book of good sense, good reading and good medicine.

**Baltimore Evening Sun:** A scientific book, but its authors have the knack, which was so wonderfully developed by Professor William James, of putting the truths of science into clear, epigrammatic, idiomatic English.

**Buffalo Commercial:** We may thank the authors for the clear manner in which they have explained much that has to do with the discoveries of Freud.

At All Bookstores  
Published by

THE CENTURY CO.

353 Fourth Avenue  
New York City

## More New Books for Boys and Girls

# ANIMAL LIFE IN FIELD AND GARDEN

By JEAN-HENRI FABRE

THE most charming of writers on natural history tells his two nephews stories about the animals, birds and insects whose life-habits affect the crops of field and garden and orchard. He surprises them by showing them that many of those little creatures we have always scorned or feared are our very powerful, and even much-needed, friends. *Illustrated. Price \$2.50*

# GOLF FACTS FOR YOUNG PEOPLE

By FRANCIS OUMET

THE "veteran" golfer, who has been amateur champion, victor in many hard-played matches, and is just as keen and expert a player as ever, gives to young people the advantage of his golf-wisdom, and the results of much observation, many friendships and wide contacts with the great game. He himself began golf young on an improvised course, and he understands the problems of youthful players: the pitfalls to be avoided, the difficulties under which they must sometimes develop their game.

*Illustrated. Price \$1.75*

# BROTHER ESKIMO

By ALAN SULLIVAN



"A YOUNG Mowgli of the North," a professional reader called the hero of this book. He is carried away in his father's igloo on the ice-floe, far from any place he knows, with only his younger brother for companion. The strange life of the north, every condition of which is strange as dreamland to us, Mr. Sullivan knows well and describes accurately and fascinatingly. The two boys go through many adventures, in which wild animals

play a large part, life itself depending upon their knowledge of the arctic creatures.

*Illustrated. Price \$1.75*

# THE BOYS' BOOK OF MODEL AEROPLANES

By FRANCIS A. COLLINS

AN up-to-date new book covering all of the phases of young people's interest in the art and science of the aeroplane, including clubs, tournaments, prizes, etc., and giving models, discussion of principles, building and flying instructions, and photographs of actual planes of all types, often with their young builders and flyers. This supersedes two earlier boys' books of model aeroplanes by Mr. Collins. *Illustrated. Price \$2.00*

At All Bookstores  
Published by

THE CENTURY CO.

353 Fourth Avenue  
New York City



Order Every Novel Here—You Can't Go Wrong

## BIRTHRIGHT

By T. S. Stribling

ONE of the most widely discussed novels of the season. Gertrude Atherton says "Birthright" is "a remarkable and significant book." Charles Hanson Towne of *The New York Tribune* says "it is the finest American novel of a decade." Maurice Francis Egan says it is the best novel yet written based on the situation of the negro in the United States; and concludes, "no one can read Mr. Stribling's very passionate novel without believing that a writer of great importance has found his *metier*." *Illustrated.* \$1.90

## THE ROAD TO THE WORLD

By Webb Waldron

PEOPLE who are keen to know first the best things going on in the artistic world should get this extraordinary novel at once. There isn't a shoddy, shabby, flamboyant thing in it. It is thrilling, not because it is violent, but because it is so immaculately sincere. And its style is almost a miracle in present-day writing. Recommended without reserve. \$1.90

## CARAVANS BY NIGHT

By Harry Hervey

H. L. MENCKEN says: "Exotic fires glow in 'Caravans By Night.' . . . More, he knows how to tell a tale. . . . His singularly dramatic and thrilling visions. . . . Mr. Hervey is, in romance, the most promising neophyte in many years. . . . If you sicken of psychology and would immerse yourself for a space in very wild doings under distant and chromatic skies, then I commend 'Caravans by Night.' It will give your vertebrae a salubrious rattling." \$1.90

## WITHOUT COMPROMISE

By Lilian Bennet-Thompson and George Hubbard

A NOVEL of love and political intrigue whose tense, gripping action centers in an attempted lynching. A most important feature of this unusual novel is that it is one of the few which have undertaken to show how a mob is roused to the lynching mood and the probable real motives which underlie a large number of these recurring insanities which disgrace our civilization and our law. \$1.75

## THE BRIDGE

By M. L. C. Pickthall

"A NOVEL rich in verbal gems and powerful in its dramatic qualities. . . . Through three tremendous periods goes the hero of 'The Bridge'—through the sand, the mist and the snow—through mental perturbation more poignant than any physical pain ever can be. And he who begins this troublous journey with the youth who worked out in the snows of the North the great problem that came to him in the sand will not be persuaded to quit the pilgrimage until the whole matter is settled."—*Philadelphia Record.* \$1.75

## DAVID THE SON OF JESSE

By Marjorie Strachey

IN this most unusual novel, set in Biblical times, the sister of Lytton Strachey gives a portrait of a king as clear and frank and memorable as that famous portrait of a queen by the author's brother. "David The Son of Jesse" is rich with color, movement and character; and the background of cedar-clad hills and gentle valleys is made fascinatingly vivid to the reader. \$1.75

At All Bookstores  
Published by

**THE CENTURY CO.**

353 Fourth Avenue  
New York City

## Century Juveniles Are Famous

# THE LUCK OF DENEWOOD

By EMILIE BENSON KNIPE and ALDEN ARTHUR KNIPE

**A**NOTHER of the popular Denewood stories, in which the lost lucky sixpence, the Luck of Denewood, is found by charming Beatrice de Soulange, descendant of Stuttering Peg Travers, and her American cousins, whereupon the fortunes of the house of Denewood mend. *Illustrated. Price \$1.75*

# TALES OF TRUE KNIGHTS

By GEORGE PHILIP KRAPP

**A** NUMBER of the marvelous, brave and lovely legends the old chroniclers and minstrels have saved for us, in legend so dim or language so strange that they need be retold for modern readers, have been selected by Professor Krapp of Columbia University and delightfully retold in a form perfectly clear and infinitely fascinating to children. Among the tales are: Sir Cleges; King Horn; Havelock the Dane; Werewolf; Sir Gawain and the Green Knight; The Three Revelers. A beautiful and worth while book.

*Illustrated. Price \$1.75*



# CONQUESTS OF INVENTION

By MARY R. PARKMAN

**N**OT the average compiled book of this kind, but a living, glowing, enthusiastic yet well-balanced account of important inventions which have changed man's material environment by adding to his resources in food, clothing and machine energy; to his range of activity, in the air and under the water; to his ability to communicate quickly and across great distances, etc. It is extremely readable and worth reading. Numerous reviewers have remarked that it should interest both young folk and their elders.

*Illustrated. Price \$2.00*

# KIT, PAT, AND A FEW BOYS

By BETH B. GILCHRIST

Author of "Cinderella's Granddaughter," etc.

**T**HE sophisticated daughter of a family whose relations to each other were just remotely and conventionally affectionate is not conscious of being wistful. But when she is plucked, by chance, into the midst of a frank, hearty, openly loving, companionable family group, she awakens to certain things she has been missing. A wonderful summer in camp leaves her with more than memories of lakes, pines, and sunsets.

*Illustrated. Price \$1.75*

At All Bookstores  
Published by

**THE CENTURY CO.**

353 Fourth Avenue  
New York City





# “AD” VENTURES of the IVORY HEROES



## A Cure for Woe Chapter VII.

a happy man, save for *one* sadsome grief and no one he had ever found could cure or bring relief.

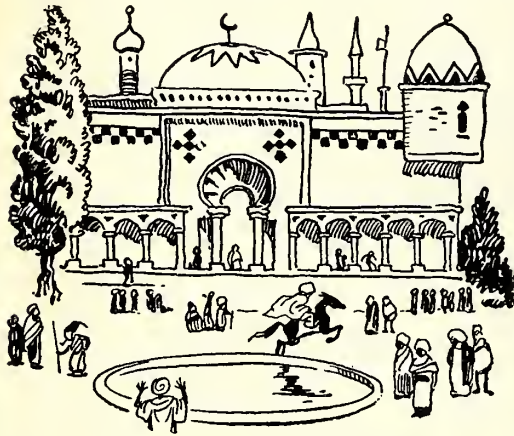

You see, his wealth was *in his house*, upon the walls and floors in very costly tapestries and rugs before his doors. From his own dad and foredads came for many a generation the secret recipe to keep his rugs from devasta-

O Bobby White, and Betty Snow, and Gnif, and Yow, and Snip, set out for more adventures in their IVORY bubble ship. Ere long our heroes spied a park they thought they'd like to visit, for after work a little rest is not a bad plan, is it? Inside the park a palace stood—a Sultan's palace where ten hundred gorgeous servitors were strutting here and there. The Sultan was



tion. But he had *lost* this recipe, and though he offered gold to save his precious rugs, they grew all dirty, dim, and old. When deeply down in doleful dumps, not knowing what to do, he heard the gloom-destroying shouts of our glad IVORY crew. “Oh, grieve not, Mr. Sultan Man,” said Betty, “for *we* know a way to save your precious rugs and cure your sadsome woe.” The rugs of greatest preciousness Miss Betty undertook to clean when she had found the way in “IVORY Uses Book.” With IVORY suds she brushed the nap as fast as she could do it, then with a damp cloth wiped it off, but let no water through it. The carpets and the rugs less rare our Gnif and Bobby chose and scrubbed them thoroughly and then they rinsed them with a hose.

*Oh*, what a happy Sultan Man! His rugs all bright and new. He *hugged* our heroes and what's more he pinned upon them, too, the “Order of the *Elephant*” whose tusks of I-V-O-R-Y had given IVORY SOAP its name for strength and purity.

*Don't think this all a fairy tale,  
It isn't, dears, forsooth,  
The magic worked with IVORY is  
Just the simple TRUTH.*

Don't you want to see how and when these marvelous adventures began? Then write to your friends, The Procter & Gamble Co., Cincinnati, Ohio, asking for a little book called “THE CRUISE OF THE IVORY SHIP,” by John Martin. It is a wonderful little bedtime book, given *FREE* to you.



**IVORY**  
IT FLOATS



**SOAP**  
99 <sup>44</sup>/<sub>100</sub> % PURE



BOYS—Here's the gun for the 4th of July



**Absolutely Harmless**

# SHOOTS 5000 times without reloading

No Caps No Powder No Cartridges No Danger

THE Ronson Repeater brings you all the sport of a real automatic, with absolutely no danger. You not only hear it shoot, but you see it shoot, and see the smoke. It flashes—big red flashes—every time you pull the trigger. These flashes make the Ronson Repeater look just like a real gun in action. But this gun is absolutely harmless. Shoot it anywhere in perfect safety.

We know every boy will want to know what makes the flash. But that is a secret, and we can't tell. Just keep pulling the trigger. You don't have to cock this gun—it's a real repeater. Reloaded in a jiffy with Ronson Redskin Reloads, each of which shoots 5000 times. The shape, grip and genuine gun-metal finish are just like a real automatic. The Ronson Repeater is made of pressed steel—it's strong and long lasting.

Don't wait for your Ronson Repeater—get it now. Ronson Repeaters are going to sell fast for the Fourth. Buy yours before your dealer is sold out. Better get one today, and then you'll have it sure. If you cannot buy one anywhere in your town, use the attached coupon.



THE ART METAL WORKS  
39 ARONSON SQUARE, NEWARK, N. J.  
For 35 years makers of High Grade Metal Novelties.

# The RONSON REPEATER

Trade-mark registered.

Patented in U. S. A. and abroad.

—CUT OUT THIS COUPON—

THE ART METAL WORKS  
39 Aronson Square, Newark, N. J.

Enclosed find 25c in coin or stamps, for which send me one Ronson Repeater. Gun-metal finish. Loaded for 5000 flashes. (Enclose 10c extra if you live west of Chicago or in Canada.)

My name is .....  
Street .....  
City ..... State .....  
My dealer's name is .....  
Street .....

This wonderful gun costs only

**25¢**

Also made in polished nickel plate at 50c. Both are higher in the West and Canada

## Ronson Redskin Reloads

The reloads that you slip into the Ronson Repeater are absolutely harmless. Every one shoots 5000 shots! Buy several extras when you get your Ronson Repeater. You'll want 'em. Price 5c each, higher in the West and Canada.





## *Two Good Bites* Which will he attend to first?

A cake of Baker's Sweet Chocolate for lunch and when he gets home a cup of delicious, wholesome Baker's Cocoa with his supper.

*Sweetmeat, food and stimulant in one.*

"Practical experience long ago decided that chocolate is a good sustaining food." — The Lancet, London, Eng.



REG. U.S. PAT. OFF.

Established 1780

**WALTER BAKER & CO. LTD.**

DORCHESTER, MASSACHUSETTS

*Booklet of Choice Recipes sent free.*

AUGUST, 1922

# ST NICHOLAS



THE CENTURY CO

353-FOURTH AVENUE NEW YORK

THE CENTURY

AND

ST. NICHOLAS





## If You Had Been a Princess 3,000 Years Ago

**I**F you had lived in the royal days of ancient Egypt, palm and olive oils would have been your greatest luxury.

Caravan and galleon brought these rare oils in skins and jars for the use of those who could afford them.

A little princess of those classic days would use them regularly, both as a cleanser and to beautify the skin.

Palmolive soap is blended from the same palm and olive oils discovered so long ago. They were selected as ingredients for this famous soap because science in all these thousands of years has discovered nothing better.

But instead of a luxury reserved for the favored few, Palmolive is now pro-

duced for all the world to enjoy. So many people use it that the manufacturing cost has been reduced so that all can afford it.

### *Miniature Cake Free*

If you will write The Palmolive Company, Dept. B-322, giving your name and address, we will gladly send you a miniature cake of this famous soap. If you do not already use Palmolive, show this trial cake to your mother and ask her if she won't buy it regularly for you.

### THE PALMOLIVE COMPANY

MILWAUKEE, U. S. A.

The Palmolive Company of Canada, Limited  
Toronto, Canada

*Also makers of a complete line of toilet articles*

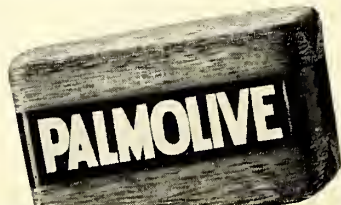

(The entire contents of this Magazine are covered by the general copyright, and articles must not be reprinted without special permission.)

## CONTENTS OF ST. NICHOLAS FOR AUGUST, 1922

<b>Frontispiece: "When Jack and Bert scanned the rippling gulf, there was no sign of the old barge."</b> Drawn by W. P. Couse		
<b>In the Wake of the Hurricane.</b> Story. Illustrated by W. P. Couse . . . . .	Charles Tenney Jackson . . . . .	1011
<b>The "Hide-y Hole on the Beach."</b> Story. Illustrated by Nat Little . . . . .	Dorothea Castelhun . . . . .	1017
<b>Splash!</b> Sketch. Illustrations from photographs . . . . .	George H. Corsan . . . . .	1025
<b>Down Among the Wharves.</b> Verse. Illustrated by I. W. Taber . . . . .	Eleanore Myers Jewett . . . . .	1032
<b>The Mystery at Number Six.</b> Serial Story . . . . .	Augusta Huiell Seaman . . . . .	1034
Illustrated by W. P. Couse		
<b>Mountain Sculpture.</b> Sketch. Illustrated . . . . .	Francis B. Atkinson . . . . .	1042
<b>The Turner Twins.</b> Serial Story. Illustrated by C. M. Relyea . . . . .	Ralph Henry Barbour . . . . .	1050
<b>The King of the Turquoise Mountains.</b> Story . . . . .	Tudor Jenks . . . . .	1058
Illustrated by Reginald Birch		
<b>The Key.</b> Story. Illustrated by Dudley Gloyne Summers . . . . .	Beth B. Gilchrist . . . . .	1063
<b>The Two Clocks.</b> Verse . . . . .	M. D. Cole . . . . .	1068
<b>In the Blood.</b> Story. Part I . . . . .	Kenneth Payson Kempton . . . . .	1069
Illustrated by I. W. Taber		
<b>The Royal Cup.</b> Verse. Illustrated by the author . . . . .	Charles F. Lester . . . . .	1076
<b>That Class Election.</b> Story. Illustrated by Edward C. Caswell . . . . .	A. May Holaday . . . . .	1078
<b>Up-to-Date.</b> Picture. Drawn by A. B. Walker . . . . .		1082
<b>Pets.</b> Verse. Illustrated by Reginald Birch . . . . .	Arthur Guiterman . . . . .	1083
<b>A Memory Chain.</b> Sketch. Illustrated . . . . .	Ruth H. Withington . . . . .	1084
<b>Success and Failure</b> . . . . .	Hildegard Hawthorne . . . . .	1086
<b>Peg Furniture.</b> Sketch. Illustrations from photograph and diagram . . . . .	C. K. Taylor . . . . .	1088
<b>The Inca Emerald.</b> Serial Story. Illustrated by Charles Livingston Bull . . . . .	Samuel Scoville, Jr. . . . .	1090
<b>The Watch Tower.</b> A Review of Current Events. Illustrated . . . . .	Edward N. Teall . . . . .	1097
<b>Nature and Science for Young Folk.</b> Illustrated . . . . .		1103
Pilotless Aircraft and Seacraft (M. Tevis) — Wheat Now Grown Near Arctic Circle; — Vices and Virtues of the Cacti (J. Smeaton Chase) — Straw as a Building Material (Donovan McClure) — Apes Test Money — A Cubical Bubble (S. L. Bastin)		
<b>For Very Little Folk: A Fairy Compromise.</b> Story . . . . .	Clara I. Judson . . . . .	1108
Illustrated by Marion T. Justice		
<b>The St. Nicholas League.</b> With Awards of Prizes for Stories, Poems, Drawings, Photographs, and Puzzles. Illustrated . . . . .		1110
<b>The Letter-Box</b> . . . . .		1118
<b>The Riddle-Box</b> . . . . .		1119
<b>St. Nicholas Stamp Page.</b> Conducted by Samuel R. Simmons . . . . .	Advertising Pages	

*The Century Co. and its editors receive manuscripts and art material, submitted for publication, only on the understanding that they shall not be responsible for loss or injury thereto while in their possession or in transit. Copies of manuscript should be retained by the authors.*

In the United States, the price of ST. NICHOLAS MAGAZINE is \$4.00 a year in advance, or 35 cents a single copy; the price of a yearly subscription to a Canadian address is \$4.35. The price of a yearly subscription to a foreign address is \$4.60. We request that remittances be by money-order, bank check, draft, or registered letter. The Century Co. reserves the right to suspend any subscription taken contrary to its selling terms, and to refund the unexpired credit. PUBLISHED MONTHLY.

The half-yearly parts of ST. NICHOLAS end with the October and April numbers respectively, and the red cloth covers are ready with the issue of these numbers; price \$1.00 by mail, postpaid; the two covers for the complete volume, \$2.00. We bind and furnish covers for \$2.00 per part, or \$4.00 for the complete volume. (Carriage extra.) All copies of this magazine which are to be bound must be sent to our New York office. In sending the numbers to us, they should be *distinctly* marked with owner's name. Bound volumes are not exchanged for numbers.

All subscriptions for, and all business matters in connection with, ST. NICHOLAS MAGAZINE should be addressed to

**THE CENTURY CO.**  
**Publication and Circulation Office, Concord, N. H.**  
**Editorial and Advertising Offices, 353 Fourth Ave., New York, N. Y.**

W. MORGAN SHUSTER, *President*  
 DON M. PARKER, *Secretary*

GEORGE L. WHEELOCK, *Treasurer*  
 JAMES ABBOTT, *Ass't Treasurer*

BOARD OF TRUSTEES

GEORGE H. HAZEN, *Chairman*

VOL. XLIX.

GEORGE INNESS, JR.

W. MORGAN SHUSTER

No. 10

(Copyright, 1922, by The Century Co.)

(Title Registered U. S. Pat. Off.)

(Printed in U. S. A., and Entered as Second Class Matter, September 4, 1920, at the United States Post Office, Concord, N. H., under the Act of March 3, 1879. Entered at the Post Office Department, Ottawa, Canada.)



# ST. NICHOLAS

---

## NEXT MONTH AND TO COME

---

### **The Radio Message**

**GEORGE E. WALSH**

Campers need no longer depend upon the rural telephone and the R.F.D. for an occasional word from "civilization." The radio brings the camp-fire concert, and the latest news. And the news which was received by the boys of this story not only affords diversion, but leads to the capture of a clever criminal.

### **The Story of the Trolley**

**T. COMMERFORD MARTIN**

The street car is such an ordinary means of travel in these days of super-speed that we forget it was once a novel thing; and not so many years ago at that. This article tells, in a fascinating manner, of its invention and development.

### **The Thoroughbred**

**A. MAY HOLADAY**

Some boys devise a simple way to test two candidates for a college office. The reaction is so marked that there is no longer a question in any mind as to the choice.

### **Golf for Boys and Girls**

**CECIL LEITCH**

The former British women's champion gives some hints to those just beginning the game.

### **The Handicap**

**BREWER CORCORAN**

A tenderfoot at camp proves she is not as tender as her tent-mates think, and when it comes to the canoe race, she paddles almost as well as an Indian.

### **The Oddsocks**

**MORTON GIBBONS-NEFF**

An ancient hulk, once a winner in "sneak-box" races, is brought to light and fame once more—a good story of sailing-craft and boy-skippers.

# The Book You've Been Wanting

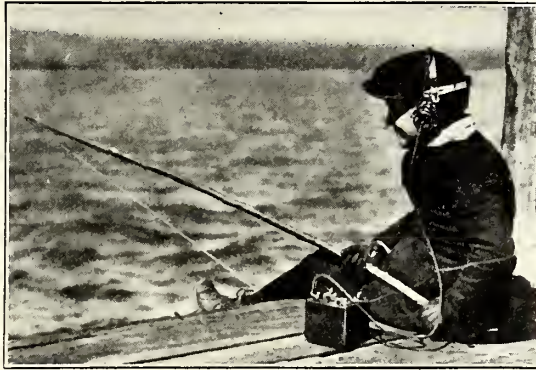

## THE COMPLETE RADIO BOOK

By Raymond Francis Yates and L. G. Pacent

**Q** DON'T YOU WANT to know radio better? — the thrilling story of its development from a ridiculed "crank" notion to the immensely popular and powerful thing it is today, when newspapers run columns and columns about it? Whatever other books you have about radio, if you are a real "bug" you want this one. It has chapters on the how and why of radio, with lots of diagrams, sketches and photographs; accounts of the latest wonderful things radio is doing all over the earth; a most fascinating history of the way radio was discovered and developed; and a Who's Who in radio of the greatest interest and value. No other radio book has so much of absorbing story-interest in addition to the scientific and practical part.

**Q** RAYMOND FRANCIS YATES is radio editor of "The New York Evening Mail."

**LOUIS GERARD PACENT is one of the best-known radio engineers and inventors.**

**The  
Century  
Co.**

353 Fourth Avenue  
NEW YORK CITY

I enclose \$..... for..... copies

**THE COMPLETE RADIO BOOK**

**\$2.00**

Send to.....

Address.....



# School Selections

LET the children help choose their school. They are the ones concerned chiefly. Eight months or thereabouts from the year are to be spent away from home in surroundings that may or may not be congenial. If congenial, then the probabilities are that the school year will be successful. If uncongenial, the children do not respond to the benefits that should naturally come.

¶ The spirit of coöperation can be aroused best by creating consciousness in the minds of children that they themselves are responsible as well as the parents, for the outcome of the school year. Should the child be allowed to give expression to his preferences, and should he be permitted to take his place in a general discussion, the decision arrived at really establishes in the child his realization of responsibility.

¶ Enthusiasm, too, is necessary, and where the school is chosen after the prospective student's likes and dislikes are listened to, the chances are that the child goes away fired with both of these necessary foundations—the spirit of coöperation, and enthusiasm for the school selected. There is happiness for the contented student, and eight months of restlessness and dissatisfaction, not only for the child but for schoolmasters and parents as well, where these are missing.

¶ The final decision as to what will be the selected school will always remain with the parents, but attention paid to the likes and dislikes of the child will, we believe, be a profitable investment.

¶ We are always glad to be of any possible service that will help solve knotty problems. A line to us will bring our best efforts.

ST. NICHOLAS SCHOOL SERVICE DEPARTMENT  
353 FOURTH AVENUE, NEW YORK CITY

*Please have information about schools sent to me:*

My age is.....

Name of school I have attended .....

Name.....

Address.....

Location desired.....

Large or small school.....

Type (*i. e.* Boarding, Military, etc.).....

Parent's

Signature.....

# GOOD SCHOOLS

— FOR —  
BOYS and GIRLS



## PAGE Military Academy

*A big school for little boys*

Page stands in a class by itself as a military school for little boys. Sound training in the common branches comes first. The military is adapted to young boy needs. It means manly little men who will grow up into courageous, successful, big men. Parents appreciate the atmosphere of sympathy, understanding and encouragement for their little boys at Page. Lady teachers to fifth grade. Tender care of House Mothers.

The catalog will surely interest you. Write for it to

**ROBERT A. GIBBS, Headmaster**  
Route 7, Box 947 Los Angeles, California

## COLUMBIA PREPARATORY



### SCHOOL BOYS GIRLS



Preparation for all Colleges and Universities. Sponsored by University Presidents. Patronized by University faculties. Member University of State of New York.

**Day and Resident—Primary to College**

*Combining the most progressive methods of education with the cultural advantages of New York*

Ideal home life for refined, cultured girls and boys of all ages, under an experienced faculty composed of Europe's and America's most eminent teachers, who are masters in social and academic training. Separate departments for Art, Music, Dramatic Art and Junior Divisions.

**DR. S. N. CLAWSON, Principal**  
301 W. 88th Street, Cor. West End Avenue  
New York



## The Hedges

NORTON, MASS.

The Junior School of House in the Pines. 30 miles from Boston. For girls under fourteen. A large modern home. Sun parlors for class rooms. Play fields. Horseback riding. Swimming. A wholesome, simple life of study and play that makes the child quick to feel, eager to know, able to do.

**MISS GERTRUDE E. CORNISH, Principal**



## RYDAL Junior Department of the Ogontz School

A fifteen-acre private estate on the Rydal Hills is the home of the Rydal School, for girls 9-14 years. Same management as Ogontz School, but a separate school in buildings, faculty, work and play. Parents will find at Rydal the same unusual opportunities that make the Ogontz School distinctive. Teacher of strong personality and experience in charge. Enrollment limited. Visit the school or write for book of views and "Letter to Mothers." Address

**Miss Abby A. Sutherland, Rydal, Montgomery Co., Pa.**

CONNECTICUT, Cornwall.

## RUMSEY HALL

A School for Boys under 15. Yearly rate \$1300.

**L. R. SANFORD, Principal.**  
**LOUIS H. SCHUTTE, M.A., Headmaster.**

RHODE ISLAND, Providence.

## THE MARY C. WHEELER SCHOOL

*A Town and Country School for Girls*

College preparatory and General Course. Advanced Studio classes. Music. Secretarial Course. Farm Home for girls 10 to 14 years.

CONNECTICUT, New Canaan.

## STAMFORD MILITARY ACADEMY

Thorough scholastic and military training fostering the intellectual, physical and moral needs of developing boys. Personal instruction. Small classes. Manly sports encouraged. Extensive equipment. Ideally located in the Connecticut hills. Summer Camp.

**WALTER D. GERKEN, A.M., Principal, New Canaan, Conn.**



# TENACRE



Riding  
Class at  
TENACRE

*A Country School for Young Girls  
from Ten to Fourteen Years of Age*

**P**REPARATORY to Dana Hall.  
Fourteen miles from Boston. All  
sports and athletics supervised and  
adapted to the age of the pupil. The  
finest instruction, care and influence.

MISS HELEN TEMPLE COOKE  
Dana Hall, Wellesley, Mass.

## Miss Hall's SCHOOL FOR GIRLS

In the Berkshire Hills, on  
the Holmes Road to Lenox.  
Forty-five acres. One thou-  
sand feet above the sea level.

Miss MIRA H. HALL, Principal  
Pittsfield, Massachusetts

## The Castle

**Junior Department of Miss Mason's School**  
For the little girl who wants a school like older  
sisters. Work and play directed for the steady  
development of the child from 6-12 years of age.  
Unsurpassed advantages. Near New York City.  
Rate \$1000. Catalog.

Miss C. E. MASON, Principal  
Box 725, Tarrytown-on-Hudson, N. Y.



## Ossining School FOR GIRLS

We offer, with diploma, Academic, College  
Preparatory, Art, Music, Dramatic, Secretarial  
and Home-making Courses, including Horti-  
culture.

Students may enter regular courses or, with  
parents' approval, may specialize as desired. In  
beautiful Westchester, 30 miles from New York.  
54th year. Write for Year Book. Address  
Ossining-on-Hudson, New York. Box 8M.

CLARA C. FULLER, Principal



## Lincoln School

A school for girls, offering country life with the advantages  
of the city. Preparation for college examinations, and  
general courses. Exceptional opportunity for outdoor  
sports. Horseback riding.

Miss Miriam Sewall Converse, Principal  
Providence, Rhode Island

# BINGHAM SCHOOL, MEBANE, N. C.

ESTABLISHED 1793

AN IDEAL BOYS SCHOOL IN PIEDMONT NORTH CAROLINA

Military organization, begun in 1861. High moral tone. Lovely lawns. Gymnasium. Athletic  
park. Bible and Physical culture emphasized. Honor System. Celebrated climate. Outdoor classes.  
Limited numbers. Sports in variety. 340 acres. Summer camp. A modern school with an  
ancient name, fame and history. Send for catalogue.

COL. PRESTON LEWIS GRAY, President, Box 8, Mebane, N. C.



# WILLISTON

## JUNIOR SCHOOL

For Young Boys

Organized to develop the entire boy. Thorough work and graded athletics. Prepares for all leading preparatory schools. Home care, under House-mother, Head-master, and Special Faculty.

Rate \$700

Senior School prepares for college and scientific schools. A progressive school with 80 years of solid achievement behind it.

ARCHIBALD V. GALBRAITH, Principal  
Box N, Easthampton, Mass.



## DUMMER ACADEMY

SOUTH BYFIELD, MASS.

160th Year. 35 Miles from Boston. 370 Acres for sports and life in the open. Athletic field, golf course, tennis court, hockey pond, salt water sports. Separate building and school for boys from 10 to 14. Play and school life carefully planned according to the needs of each boy. Infirmary. For catalogue, address

CHARLES S. INGHAM, Ph.D.

## Starrett School for Girls

Thirty-seventh year. Academic, college preparatory and special courses; also seventh and eighth grammar grades. Co-operative with the University of Chicago; prepares for Smith, Wellesley and Vassar Colleges. Member of the North Central Association. Full courses in all subjects offered by the best academic schools. European Trip — Summer 1923 — Credit given in History and Art. Exceptional advantages in Music and Art. A home school in elegant fire-proof building two blocks from Lake Front Park, Tennis Courts and Bathing Beach. Fall term begins Sept. 14.



Address Registrar, Box 28  
4932 Lake Park Ave., Chicago, Ill.

MASSACHUSETTS, Berkshire.

**CRESTALBAN** A school for little girls in the invigorating climate of the Berkshires. Thirty minutes from Pittsfield. 200 acres, 3 buildings. Number limited. Special care given to home training, character development, and health. Open-air classes. Outdoor sports. MISS MARGERY WHITING, Principal.

PENNSYLVANIA, Swarthmore.

**THE MARY LYON SCHOOL** A Country School in a College Town Preparatory for college. High scholastic standards. Music, Art, Languages, Home-making Sciences. Outdoor sports including canoeing. SEVEN GABLES — Junior School. WILNCLIFF — Graduate School. Write for catalogs. Mr. and Mrs. H. M. CRIST, Principals, Box 1542, Swarthmore, Pa.

## Miss Beard's School FOR GIRLS ORANGE, NEW JERSEY

Thirty minutes from New York City. College preparatory and special courses. Music, Art, Domestic Science. Outdoor classes. Skating, Riding, Tennis, Hockey and Basket-ball.

LUCIE C. BEARD, Headmistress



## Southfield Point Hall

A School for Girls. Beautifully situated on Long Island Sound at Southfield Point. Intermediate, general, and college preparatory courses. Music, gymnastics, athletics, and sports. Horseback riding, skating, skiing. 32 minutes from Grand Central Station, New York. Limited enrollment.

JESSIE CALLAM GRAY, B. A., Principal  
BERNICE TOWNSEND PORTER, Assistant Principal  
10 Davenport Drive, Stamford, Conn.

NEW HAMPSHIRE, Concord.

## ST. MARY'S SCHOOL

A homelike school for girls. College preparatory and general courses. MISS M. E. LADD, B.L., Headmistress.

MASSACHUSETTS, Bradford.

**JUNIOR BRADFORD** A preparatory school for Bradford Academy. Directed study and play. Arts and crafts. All advantages of Bradford Academy equipment. For Booklets, address THE "PRINCIPAL," 139 Main Street, Bradford, Mass.

250 Alert Boys 22 Competent Men  
\$800,000 Equipment

89th year opens September 19th

# WORCESTER ACADEMY

WORCESTER MASSACHUSETTS

Rates: \$1000 single  
\$850 double

Junior School for young boys

For catalog address the Registrar, G. D. Church, M.A.

SAMUEL F. HOLMES, M.A., Principal



# ABBOTT SCHOOL



Q A boys' school in the beautiful, healthful hills of the Rangeley Region, 82 miles from Portland. Thorough preparation for college or business. High ideals of scholarship. Character and body building, maintaining the best traditions of New England Academies. Small classes insure close, personal touch of earnest masters.

Q The physical development of boys is an important factor here. Exhilarating winter sports in the dry, invigorating air and an energetic outdoor life, together with gymnastic exercises and organized sports, combine to form sturdy bodies and happy minds. Gymnasium and fine athletic fields. Founded 1844. Upper and lower Schools.

Rate \$1200

Write for catalog

FARMINGTON, MAINE

## WOODLAND PARK Junior School of Lasell Seminary

Prepares for Lasell Seminary and other leading secondary schools. Careful direction under House Mother. Progressive methods of study and play. All the equipment of Lasell Seminary, with playgrounds, gymnasium and swimming pool. 15 Buildings. 30 Acres.

Camp Teconnet opens July 1st

Guy M. Winslow, Ph.D., Principal Chas. F. Towne, A.M., Associate Principal  
Woodland Road, Auburndale, Mass.



## Whiting Hall

### A Country Home School for Girls

from eight to sixteen, affiliated with the best preparatory schools. Twenty-six acres, modern buildings, new gymnasium, ideal location, high elevation—halfway between Boston and Worcester, near Longfellow's Wayside Inn. Outdoor sleeping and class rooms, if desired. Individual care. Teachers for all branches. Mistress of field games. House mother. Family life emphasized. Tenth year.

MR. ELBRIDGE C. WHITING, Amherst, Yale, MRS. WHITING, Wellesley, Prins. CONCORD ROAD, SOUTH SUDBURY, MASS.



## THE ROBERTS-BEACH SCHOOL

Limited number of girls, individual instruction. Strong college preparatory and general course. Outdoor life on ten-acre estate near Baltimore. Rooms with private bath.

BOX 900, CATONSVILLE, MD.

### Summer Camps



### For Girls (under 20 years), Roxbury, Vermont

A 300-acre wonderland in the heart of the Green Mountains. Athletic fields, private swimming pond, clay tennis courts, screened dining porch, sleeping bungalows, and a big assembly hall for plays, dances, music, and games around a big cheery fireplace. Famous for its fine saddle horses, free horseback riding, instruction, and wonderful camping trips. Separate camps for Juniors and Seniors. Enthusiastic counselors carefully chosen. Write now for illustrated booklet.

Mr. & Mrs. C. A. Roys, 10 Bowdoin St., Cambridge, Mass.



### Miss Harris' Florida School

Tourist Pupils Follow Work of Home Schools

Outdoor Classes—Ocean Bathing—Golf Throughout Winter. Boarding-School for Girls—Day-School Department. Intermediate and College Preparatory.

1061 Brickell Avenue Miami, Florida

## SCHOOL INFORMATION

FREE catalogs and advice of experts on ALL Boys' or Girls' private schools (also camps) in U. S. Bureau maintained by the schools. No fees. Want for Girls or Boys? Call, phone or write

AMERICAN SCHOOLS ASSOCIATION

Times Bldg., Times Sq., N. Y.; also Masonic Temple Chicago









“WHEN JACK AND BERT SCANNED THE RIPPLING GULF, THERE WAS NO SIGN OF THE OLD BARGE”  
(SEE PAGE 1016)

# ST. NICHOLAS

VOL. XLIX

AUGUST, 1922

No. 10

Copyright, 1922, by THE CENTURY CO. All rights reserved.

## IN THE WAKE OF THE HURRICANE

By CHARLES TENNEY JACKSON

IT was the day after the great West Indian hurricane of September, 1909, which swept across the Gulf of Mexico and struck the Louisiana coast, that Hippolyte Lange, a Creole trapper, dazed by the sun and dumb with thirst from wandering in the salt marshes, reached the tiny *chênière* where Bert Adams and Jack Reeves had found refuge from the storm. The boys had come down Bayou La Fourche back of Rose Mound plantation in Bert's launch, bringing fifteen hundred dollars to pay the crew of a dredge which was working to reclaim land for Mr. Reeves, and had not reached the swamp canal before the sou'easter struck them.

They had a rough time for three days. The sea rushed inland for forty miles over the "trembling prairies," and even where they were in the *chênière*, as the oak-grove islands are called, the water had been five feet deep. However, they weathered it under the *Lou Baby's* canopy, escaped the flying branches of the oaks, and really did not know that a great disaster had befallen the south coast until Hippolyte Lange, clinging to a plank, crossed the bayou and staggered to the launch.

"Isle L'Ourse is gone," gasped the trapper, "an' all dees camps. I only wan' live! An' my Aurelie—my leetle wans out on dat coast—all dem peoples dead, M'sieu!"

"Oh, come," said Bert, who had been working all the morning trying to clean the mud from his engine, for the launch had been

swamped under the oaks, mud plastered over its bow, and everything was wet, "I don't think it 's bad as that!"

But the Creole, when he was able to talk, after the boys had given him food and water, insisted he was the only survivor of the mink and muskrat trappers of Isle L'Ourse. He had clung to a scrub-oak while the hurricane tore their palmetto camps on the platform to rags. Every lugger and pirogue had been smashed or sunk, his comrades scattered he knew not where in the darkness, and, when the day came, Hippolyte had found himself alone in an inland sea that was sweeping back to the Gulf. A day he waited before he dared leave his oak and start through the flooded marshes northward. He had given up hope, until he saw the stranded launch in this *chênière*; now he begged the boys to go on down La Fourche with him to the last camps near the sea.

"Eh, M'sieu, my people dere! Dey dead, hongry—thirsty—boats gone! All dat live M'sieu, mus' be hangin' in de *chênières*. I mus' go find my Aurelie and de leetle wans. And my modder and my fodder and my broder—way in dem las' camps, M'sieu!"

"I don't see how you 'll get there," said Jack. "Everything up La Fourche must be torn up, too, and people too busy to come down to the coast. Soon as they know up at the plantations on the river how bad it is down here, there will be relief boats from New Orleans."



"All dem fishermans and hunters and leetle wans and women—dey can't wait, M'sieu. Can't we-all go down in your boat?"

Bert shook his head. "The *Lou Baby*'s done for. Batteries are dead, pipes choked with mud—and besides, it would take a tug to pull her out of this hole." He looked out from the broken oaks to the reedy pools of the prairie. "I think we 're in a tough fix ourselves, but we 've got fresh water and grub. We 'll all have to wait for a relief boat."

It was true. The impassible swamp prairie stretched for miles in every direction. Down the bayou, a swift and muddy tide was pouring, the sand-filled gulf water which had been piled eight feet deep over the coast was running back seaward. The boys could not go twenty feet from the *chênière* without sinking to their waists. The trapper was utterly exhausted from his struggle in the salt marshes.

But he kept up a constant appeal for his lost coast people. Jack made coffee for him and opened canned meats, and these, with salt-water-soaked bread—for the hurricane had flung the spray into everything—made up their dinner. They dug out the inside of an oak stump for a few slivers of dry wood. After he had eaten, Hippolyte lay on the tilted deck of the stranded launch and stared off southward across the glittering prairie swamp. Not a line of smoke, hardly a tree was visible in any of the far *chênière* camps. Somewhere down there, women and children were suffering; many others must have been swept to sea and lost. The boys knew how the frail shrimp-camps and trappers' shacks were built—merely on platforms or some shell ridge hardly six inches above high tides. And they knew the traditions of the Gulf hurricanes—of Last Island and *Chênière Caminada*, when thousands had lost their lives.

But Bert and Jack, sorry as they were, could think of no way to comfort Hippolyte. They had given up all hope of reaching the dredge crew through a canal miles to the West, even granting that it, too, was not destroyed. They would have to wait in this watery wilderness for the first relief boat down Bayou La Fourche.

The emotional Creole trapper, brave and hardy as he was, wept when he talked of the platform people. His wife, his children—the boys could not bear to hear him. They were both down in the launch working, discouraged, with the engine along in mid-

afternoon, when a cry from the trapper made them look up.

Hippolyte stood upright, staring northward. "Ah, frien's!" he cried. "Look—dere she come! Dat, relief boat, *le bon Dieu!*"

The boys scrambled out of the hull, incredulous. It was not possible! But there, half hidden by a curve of the marshy shore, yet plainly moving on in the current, was a boat. They saw a fore-staff with a limp rag fluttering, and at the stern the deck of a tiny cabin.

"One of the Barker barges!" exclaimed Jack. "But who 's pushing it? I don't hear any tug!"

"No," muttered Bert. "That 's funny, too. Look at her—not a man on her!" Then, as the low black barge swept around the bend and bore down on them, he added: "Gone adrift, sure as shooting! Sure as anything, the tow-boat 's gone down up the bayou. And a potato-boat, Jack!"

"Sure is. I can see 'em, Bert. Piled to the guards with sacks. But her deck-house is smashed and her sweeps gone!"

"Ah, M'sieu—she be swep' out to sea—and wiz all dem 'tatoes! Eh, and water—sho' M'sieu, she mus' have a tank 'at catch rain!"

"Let 's try to warp her ashore!" cried Bert. "Make a swim for it, Jack. It 'll be worth money to save her. There may be five hundred dollars' worth of potatoes on board."

The young engineer was already eagerly throwing off his clothes to swim for the barge when Jack and Hippolyte cried out together with a great idea.

"Stop her? I tell you," shouted Jack; "let 's get *on* her—and let her go! All those potatoes—for the people down below!"

The Creole was yelling excitedly. All his weakness gone, he plunged into the water and was swimming out to meet the derelict. Bert went after him. Jack had all the currency to pay his father's dredge hands in the belt about his waist. There was nothing else in the launch that needed care except this pay-roll, and he thrust the belt under his shirt. Then he too plunged in. The wiry Frenchman was up in the fore-chains of the barge and helping Bert to come after him when Jack reached it. Then—crash! It rammed into the soft bank, heeled around, and drifted on. The three fugitives raised a shout of delight. The open barge was banked full of sacked potatoes, and her rain-barrels behind the

wrecked deck-house were abrim with sweet water. Of course, she had much water in her hold; the lower tiers of sacks were washed by the brine. But there were food and water enough for all the homeless people of the south coast.

"If we can only get it to 'em!" cried Bert. "It 's something better than salving it for

castaway potato-boat down La Fourche to succor the starving ones. Bert had been thoughtful enough to bring a bag of coffee and the little dripper, and these, with the matches in Jack's waterproof box, gave the trapper occupation in supper-getting. He built a fire with wreckage of the deck-house, and, when the ashes were red-hot, laid a row



"'ISLE L'OURSE IS GONE,' GASPED THE TRAPPER, 'AN' ALL DEES CAMPS. I ONLY WAN' LIVE!'"

ourselves. There 's one sweep left, Jack. Anyhow, we can keep her in the current—and just look at the tide run out!"

"I 'm right with you," answered Jack; "but if we can't manage her when we reach La Fourche pass, we 'll be mighty lucky not to be carried out to sea. But there 's time enough to worry about that. What we want to do is to look out for some poor chap shipwrecked in the marshes. Keep an eye out on both sides."

"She does n't need much steering, that 's a fact. Keep her off the bank and let her run. I only hope the water 's not gaining in her. If she went down anywhere, *we 'd* be in a fine fix!"

But the eager Hippolyte would not listen to such talk. He shouted and sang his thankfulness. God had surely sent the

of fine big potatoes in them, shouting with his new hope.

"I only trust," muttered Jack, "he *does* find his people. He 's so dead sure of it now! I 'm afraid—to see how everything down here is literally twisted to pieces by the wind—that all the platform camps are gone!"

"Pretty slim chance!" Bert agreed. "But we 'll do our best."

Hour after hour of the hot afternoon went by. The few *chênieres* were dim and far over the limitless marshes. The sun swung low in the west.

Hippolyte was silent now. He stood on the fore-deck straining his eyes and ears southward. Nothing in sight but the wind-beaten grasses; not a sound save the murmur of their blades when the barge brushed too near the muddy banks. Several times it



grounded gently, but the boys worked it off with poles and the sweep oar. They had eaten their blackened potatoes without salt and drunk the coffee, wishing they had brought some bread from the launch.

"Bert, it was like us to start off on this without thinking of consequences, was n't it?" murmured Jack.

"Did n't have time to think of anything except the chance of getting at some of those people down below. Anyhow, we 're all right—except—well—"

His pal glanced at the young engineer. "What?"

"Well, the bayou 's widening out so! It 's a mile now. By dark, we can't see the shores. And, son, if we get outside and into the breakers, this old tub would break up like a soap-box!"

It was true enough. Even Hippolyte was depressed. Not a sign of life anywhere. Once they passed a little lugger, bottom side up and crushed; once, a dead pelican, literally whipped to death by the wind. At sunset the three castaways saw the light fading over great wide spaces of water—the salt marsh so far away it was almost hidden. Neither Bert nor Jack had ever been to the mouth of La Fourche. Hippolyte said he had sailed it once, and it was bad with bars and shoals. Jack proposed that they bring the barge ashore to discuss the situation, and then they discovered that the water was too deep for the poles, and the single stern sweep could not check her headway in the rush of the tide.

"It 's beginning to look as if we needed rescue as much as any one could," murmured Jack, as they sat in the starlight. "Not an anchor nor a rope—not a blamed thing except water and potatoes!"

He laughed, but the others could not take it so cheerfully. The Creole was discouraged at the utter desolation of marsh and water—not a light nor a sound in all the miles that stretched to the horizon. The very bars and channels seemed strange to him. Once he pointed off to the west and shook his head. A dim black cloud was obscuring the stars. The day had been calm and fair, but if a wind sprung up from that quarter, it was all up with the potato-barge. She would be sent out into the Gulf of Mexico faster than she was now going, and would break up on the reefs.

Hippolyte built up his splinter fire again. "Mebbe dey see," he muttered. "Wan leetle fire, he go long ways at night!" Then

he made coffee, and stared off into the gloom. Once the mosquitos came out by millions and followed them, and they knew the barge had neared the marsh. But they could neither see anything, nor find any bottom with the poles.

And while they sat about the tiny fire, which they wet now and then, to keep it from burning away the deck, the trapper raised his hand.

"Listen!" He stared away again. "My frien's—the sea!"

Yes, they could hear it now! A low moaning off in the warm dark. Hippolyte turned his hand the other way, after glancing at the stars. "Dat wind, he coom up from de wes'. Dat bad, my frien's. We got to keep dat pole soundin'. Mebbe we can stick aground fo' we get outside."

But Jack sounded bottom in vain. Ten minutes more, and the boom of the breakers was distinct. The wind was coming fitfully, and the smudge in the west crept higher over the stars. The water began to ripple against the barge, and presently they felt it lifting gently under them.

"We 're in the first swell from outside," said Bert. "And another thing I don't like is that the water 's rising a bit inside the barge. You can hear it wash. Soon as the swell begins to work on her, her old seams will open worse than ever."

"Maybe we 'll go aground," answered Jack. "But even if we got ashore, a day in the marsh sun would fix us, I 'm afraid."

Fifteen minutes more they waited and drifted in the swift tide. It was meeting a sea rolling in from the southwest, and the barge heaved and creaked in the darkness. Hippolyte had hard work keeping his little fire in the rising wind. Then suddenly the barge struck with a jar that startled them.

"Sink your pole, Jack!" cried Bert; "see if we can't hold her!"

But Jack found no bottom! "Hit a sand reef and bumped right over it! Is n't that tough luck? If we 'd been *trying* to travel, she 'd have stuck for a week!"

Over this sand-ridge the sea was pounding heavily. Again and again Jack thrust the sixteen-foot pole down and found nothing. Off to port they now heard the boom of the breakers.

"Hope we hit 'em!" Bert cried. "Rather land up there than go to sea in this tub!"

"She 's wobbling crazy enough already. And the water 's gaining, Bert. It 's over the third tier of sacks down there, now."



"A SHRIMP LUGGER, LITERALLY RUNNING OVER WITH PEOPLE" (SEE NEXT PAGE)



And while the two boys were standing up, keenly alive for the first time to the desperate peril, the coast trapper, whose keen senses, as he crouched by the fire, had been alert to every noise or motion, stirred again.

"Dat!"

"What?"

Hippolyte crept to his feet. "Some wan! Leetle voice—way off!"

"Voice? Out here? Why, man, we 're in the Gulf!"

"Leetle voice—far!"

Then the two Americans heard it. Some one shouting—very faint and far above the wind and the splash of water against the barge, and the boom of the surf. Some one—and seaward!

"What are they doing out there?" cried Jack. "It can't be!"

"Dey 's comin' in!" shouted Hippolyte; "some o' my los' people! Dey 's comin' back from sea!"

The watchers could now hear voices plainly—men's hoarse shouts, and finally a woman crying. They could do nothing but stand on the barge deck and answer with all their power. But the strangers were coming nearer, either drifted by the wind and waves, or by propelling their craft. Hippolyte was dancing with excitement. He knew all the platform dwellers; whoever they were, they would be friends, and perhaps could tell him of his lost family.

And presently, so close that it startled them, they saw the eyes of men shining off in the dark; men crouched and men upright about the broken stub of a mast—a shrimp lugger, broad, low in the water, and literally running over with people. There were other men at the sweep oars, and now the last few pulls drove them alongside. Then they rested, and the gaunt-faced fellows in the bow were pouring out an excited stream of "Cajun French" to Hippolyte. The American boys looked down and listened. Then they helped half a dozen of the fugitives to the barge deck.

And the cries and shouts that went up from the shipwrecked fellows! They were down among the derelict's potatoes, eating them raw, and calling to the women and children in the lugger! But most of the children were waiting for water. The men in the lugger passed up their empty demi-johns, and, despite the warnings of the Americans, the entire company drank all they wished. The lugger captain, Florion Forêt, went on to relate the story—how the

platform dwellers at Isle L'Ourse had watched the sea rising for three days under the gale, until at last it was roaring under their pilings and one by one the flimsy houses fell. They thought that their comrade, Hippolyte, had been drowned. So, at the end, the shrimp fishers chopped out the huge masts of their lugger, put the women and children in and pushed off, to drift inland with the storm. Over the marshes, amid logs and wreckage, they went for hours, until the usual dreaded "west shift" of the hurricane took place and the piled-up waters rushed to sea. Captain Forêt's lugger had been swept many miles out; the men had fought the storm for forty-eight hours before it died down. Then they started to row landward, and for a day in the hot sun and a night, without water or food, pulled at the oars. There were thirty-two souls, of whom eight were women and seven were children. When night came on, the fishers had placed the babies inside their shirts to warm them while their fellows rowed.

"Well, well!" cried Captain Forêt; "in the dark we would not have found the bayou's mouth if it had not been for your fire. And then, M'sieus, the children would have died before we reached solid land and found fresh water! Eh, it is well that Hippolyte started to find his Aurelie!"

The happy Hippolyte was with his young wife and children. He brought Bert and Jack down among the Cajuns and heaped praises on them.

"Eh, I would 'ave die' in de marsh if dey 'ave not foun' me—an' nevair could I 'ave brought de potato-boat to sea widout dem!"

"I guess we 'd all better get off the potato-boat," answered Bert: "she 's drifting seaward and settling lower every minute. Captain, come, let 's load a dozen sacks on your lugger. We 'll find use for 'em."

They lined the lugger deep as possible with sacks; then filled the water-casks. After that, the happy Cajuns, ever light-hearted in the face of danger, set to the oars. Two hours later they had found the bayou mouth, and five miles up made camp on a bar.

And the next morning, when Jack and Bert scanned the rippling Gulf, as far as they could see, there was no sign of the old potato-barge. It was another day's pulling up La Fourche before the fugitives were picked up by a relief boat from the river, which also rescued many others.

# THE "HIDE-Y HOLE" ON THE BEACH

By DOROTHEA CASTELHUN

THE big limousine came to a stop. The road had ended, and beyond was only sand.

"Wait here, Packer; I'm going to walk over to the ocean," and from the luxurious car stepped a beautifully dressed woman.

She went straight out across the dunes, her dainty French-heeled shoes sinking into the soft sand at every step, the stiff beach-grass catching at the delicate taces of her skirts. She paid no heed, but hurried on until she reached the top of the second sand-knoll, and there she paused, staring about eagerly.

Before her lay a long stretch of shore, where the waves rolled in and broke, one after another, with endless lines of white foam. From the blue ocean came a steady breeze, heavy laden with salt fragrance, and the deep-blue surface of the water was ruffled—"White caps," murmured the beautiful lady.

She spread out her arms and let the wind blow wide the full, light silk cloak she wore over her lacy dress; she took deep breaths; and she gazed at the sea with an eager, hungry look, as if it were a long time since she had seen it.

Toward her right stretched miles of low sand-hills crowned with patches of waving beach-grass, bayberry bushes, and rambling shrubs—no sign of house or home. To the left, however, a short distance away, stood the first of the summer cottages, a quiet colony extending along the shore for a mile or two. They were mostly unpretentious frame houses, and there were nowhere any signs of the usual beach amusement-parks—no merry-go-rounds, no casinos, no pop-corn stands or souvenir booths. A few children were scattered along the shore, and back in the quiet waters of an inlet a white sail or two could be seen. Behind the narrow stretch of sandy hills edging the shore lay the broad salt marshes, and the road over which the big limousine had come wound carelessly across till it disappeared in the clustering trees that fringed the town beyond.

"It's almost exactly the same—a few more cottages perhaps. I wonder what ours looks like now? No, I guess I'd rather not see."

She turned with a sigh and started to

thread her way slowly back to the car. Then suddenly she stopped, and her face lighted up with a gleeful smile. She looked down at her feet "I wonder!" She murmured. "Could that be a 'hide-y hole'?"

The tall beach-grass grew in clumps with wide spaces between, forming little sandy squares and circles; in the middle of one of these places a low green plant was growing, a queer, straggling sort of plant, covered with sharp bristly thorns. The sand around the plant did not show the wind-swept smoothness of the rest of the hollow; it looked as if it had been carefully smoothed, indeed, but by human hands, and there were signs of the ground round about having been recently walked upon.

The beautiful lady dropped down on her knees, and, with her beautifully kept hands, she dug the sand away from underneath the prickly plant.

"Oh, it is, it is!" she exclaimed aloud, as the plant came out easily from the loose sand and a flat board was uncovered. Still carefully, she cleared away the sand from this board, lifted it, and there, under her eager gaze, was revealed the "hide-y hole." Beneath the layer of dry sand, the sand was hard-packed and damp, and in this had been dug a round hole about a foot deep and six inches wide. The board kept the dry sand from caving in, and the prickly shrub planted on top prevented any one from stepping into, and so discovering the existence of, the hole!

"To think that children still make real hide-y holes just as we did! I must see what they have in it," and she took out the small, slightly rusty tin box which lay in the bottom of the hole. In it were an old leather purse and a folded piece of paper, the purse containing a small collection of quarters, dimes, nickles, and pennies, and the paper bearing the words:

[*This is Our Buried Treasure*]

We promise to give some of our spending-money to it every two weeks, and at the end of the summer, if we have enough money, we agree to buy Tim Dugan's old rowboat which he said he might sell us. We promise not to tell any one outside of our family about this Treasure Hole.

It was signed with the names of Phyllis Ellen Clayton, Richard Clayton, Anne Clayton, Mary Clayton, and Terry Clayton



in a variety of childish handwritings. The paper itself was evidently penned by Phyllis, whose writing proclaimed her to be the oldest of the five.

"Bless their hearts! But Phyllis Ellen—strange enough, that's *my* name! I wonder who they are! I wish—" She sat back a moment with dreamy eyes, holding the paper in her slender fingers. Then suddenly she opened the jewel-studded, gold-mesh purse hanging from her arm, took out a rumpled handful of bills, and stuffed them into the old leather pocketbook.

"I don't care how much it is, and it may be a silly impulse; but when I was little, would n't it have turned the world into a golden fairy-tale if something like this had happened to *me*?"

With a tiny gold pencil she wrote across the bottom of the paper, "A contribution to the Buried Treasure Fund, from Some One who used to play here years ago and who made Hide-y Holes with prickly plants over them too!"

Then she restored the box and the board, covered it with dry sand, embedded the prickly plant firmly in its place, and rose to her feet, smiling happily.

"Oh, I have n't had so much fun for a long time!" she exclaimed. And when she was back again in the car, rolling across the quiet marshes, she was thinking, "Would n't I just love to see their faces when they find it!"

"DEAR," said Mrs. Clayton, turning her head wearily on the pillow, "will you please send the children away from the piazza to play—at least while the doctor is here? I never thought I should mind the sound of my own children, but to-day I just can't stand the racket."

"They 're terribly noisy, are n't they?" exclaimed Phyllis Ellen, anxiously. "I'm so sorry, Mother. I'll just send them off to dig for clams, I think. The tide 's almost out, and they can put on their bathing-suits and get as wet and muddy as they want to."

Phyllis Ellen was only fourteen, but, partly because she was the oldest and partly because Mrs. Clayton had not been really well for several years, she had been obliged to take a great deal of responsibility on her shoulders. The younger children, from twelve-year-old Richard down to six-year-old Terry, were quite used to accepting orders from her, and all four of them regarded her as a sort of second mother.

And so when Phyllis Ellen gave the com-

mand to dig for clams they obeyed without question. They returned a few hours later, muddy from head to foot, tired and wet, but noisily happy. A basket and two tin pails full of dripping clams proved that their digging had been successful. But their excitement was not connected with the clams. They had been to Tim Dugan's lonely shanty on their way back, and there they had seen the rowboat which was the goal of their dreams, the object of their Buried Treasure.

They burst in on Phyllis Ellen and began to talk all at once.

"Say, Phil," exclaimed Dick, dropping his basket of clams with a careless crash, "say, Tim said we could pay half this year and the rest next summer if we wanted the boat now—"

"Oh, Phil, there 's a rudder, too!" cried Anne; and, "Oh, Phil," chimed in Mary, "Tim 's got some white paint, an' he said if we wanted to paint the boat, we could do it ourselves—"

"Oh, Phil!" squealed Terry, hopping up and down, his eyes shining, "I want to paint the boat too—don't let Dick an' Anne an' Mary do it all. I *can*, can't I, Phil? It 's my boat too, is n't it, Phil?"

"Children, you must be quiet. Mother can't stand a noise right now. Dick, please wash the clams and put them on to steam before you get cleaned up for supper. The rest of you get dressed as quick as you can—and do be quiet about it," ordered Phyllis Ellen, ignoring all these appeals; "after supper we'll go down on the beach and have a meeting of the Buried Treasure Club and talk it all over."

In spite of having to stop and prepare the clams for steaming, Dick was the first one to appear in the kitchen again. As he burst in, he saw Phyllis Ellen wipe her eyes and hastily stuff a handkerchief in her pocket.

"What 's up, Phil?" he asked anxiously.

"The doctor was here this afternoon," answered Phyllis Ellen, keeping on with her supper preparation as she talked, "and he said mother ought to stay right here for another three weeks or a month. She ought not to be moved now, because she could n't stand the train trip back home; and she ought not to go back to the city at all while it 's still hot. If we could only stay till the middle of September, she 'd be ever so much better and have a good start for the winter."

"Well? Well, can't we stay?" asked Dick. "I don't think any one has rented the cottage after us."



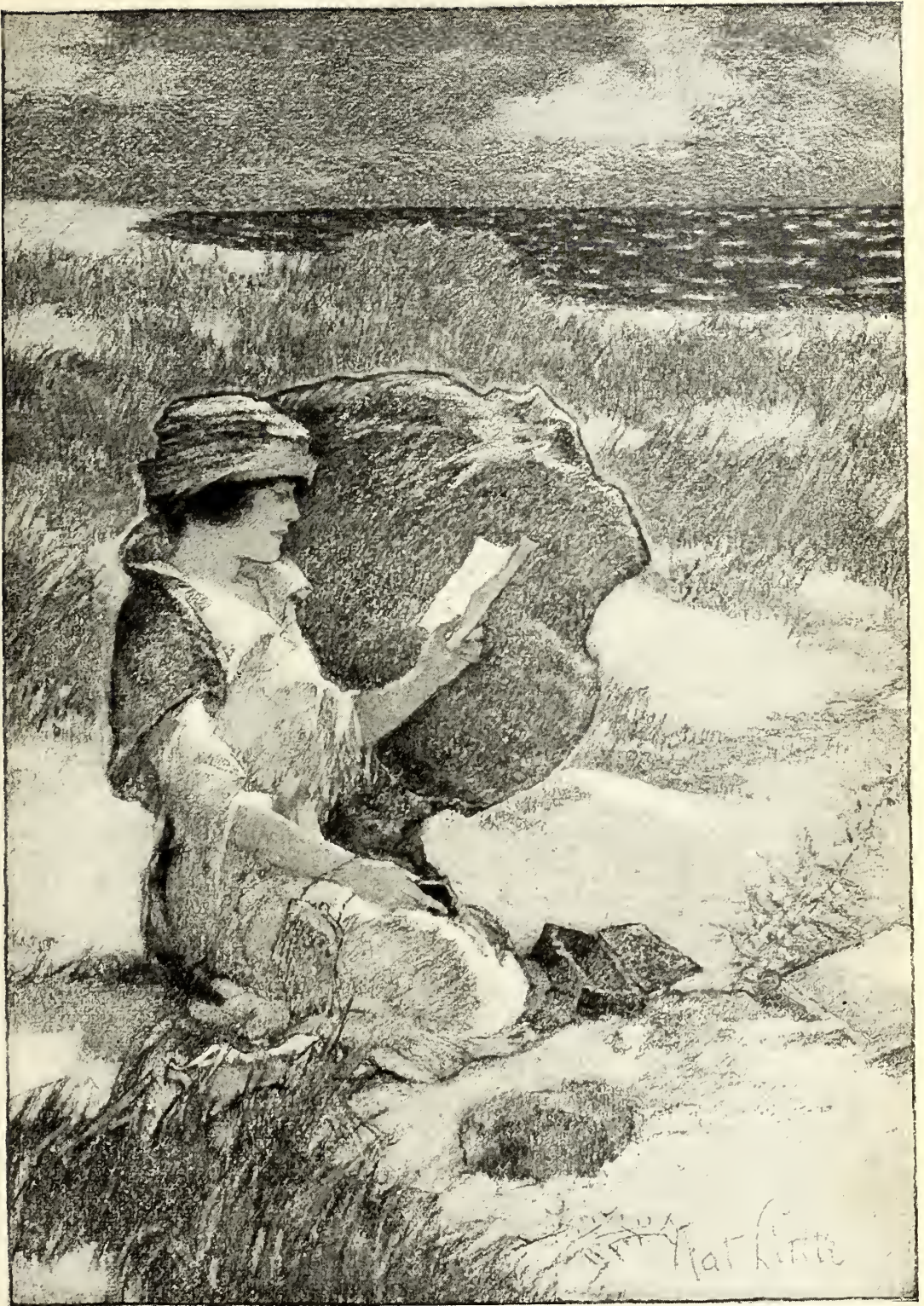

"BUT PHYLLIS ELLEN? STRANGE ENOUGH, THAT 'S MY NAME! I WONDER WHO THEY ARE!"



"It is n't that, but we have n't enough money to pay any more rent here. We have to leave the end of this week. Mother said Dad wrote that he wished he could have us stay longer, but the store has n't been doing so well lately, and he just could n't send any extra money."

"Jiminy!" whistled Dick, softly, staring out of the window.

"Oh, here come the children!" exclaimed Phyllis Ellen, suddenly; "don't say anything to them now."

In a few minutes they were all seated around the table, sniffing hungrily at the delicious smell which came from the huge dish of steamed clams.

"I think I ought to have extra clams," announced Anne, " 'cause I dug the most."

"My goodness, I'd like to know if you did!" cried Mary, tossing back her bobbed hair with indignant scorn; "I filled one of the pails all myself. I guess you did n't get any more than I did."

"I guess I *did*," retorted Anne; "I guess I worked longer than you did; I guess I—"

"Hey, cut it out, kids," commanded Dick, in his most grown-up manner; "you 're all going to get the same number of clams anyway. Phil always deals 'em fair, does n't she? You can't expect her to count each one."

Terry had been silent during the passing of these remarks, but he suddenly burst forth:

"Anne, Anne, greedy Anne,  
Tries to eat more than she can!"

Phyllis Ellen looked at him in surprise. "For goodness' sake, Terry, who taught you that?"

"I sha'n't tell," said Terry, with an impish grin; "I got it put away in a hide-y hole and s'more too—'bout all of you!"

"Oh, Terry!" exclaimed Phyllis Ellen, reproachfully, "I don't think that 's a very nice secret. Did *you* make them up, Dick?"

"Who, *me*? Not much! Must have been that fresh Nickerson kid in the red cottage across the track—"

"He 's a horrid boy," interrupted Anne, red with indignation; "Terry ought not play with him, ought he, Phil? Making horrid rhymes about me—the idea!"

"Well, you *are* greedy," said Terry, calmly; "an' you 're getting fat too; is n't she, Phil?"

"Oh, do stop fighting," ordered Phyllis Ellen, recognizing in Anne's glare the signs of an approaching storm; "we want to get the dishes done so we can go down on the beach and have a Buried Treasure meeting."

This stopped the trouble right away, and about three quarters of an hour later they were all five gathered around a big log, silvery white from long exposure to rain and sun and wind, which lay half-buried in the sand by the shore.

"Now I can't stay long, because I don't want to leave Mother alone," began Phyllis Ellen; "so we won't stop to have the regular opening and all that fuss. About Tim Dugan's rowboat now—" She paused, hating to say what she had to say because she knew how disappointed they were going to be. They were such good children most of the time, thought Phyllis Ellen to herself, and she did long to give them what they wanted.

"I 'm awfully sorry," she began again; "there would n't be any use buying the rowboat this year because, you see, we have to go back to the city the end of the week."

Mary stopped knitting her doll's sweater, Anne put down the grass basket she was weaving, and Terry released the grasshopper he had just caught—they all three stared in amazement. Dick alone did not seem surprised.

"But," exclaimed Anne and Mary in chorus, "we thought we were going to stay till September *anyway*!"

"I don't want to go to any old city *now*!" cried Terry; "we 've *got* to stay longer."

"Oh, dear, I just wish we could!" answered Phyllis Ellen; "but we can't, so we might as well keep on saving up our money this winter, and then, if we come next year, why, we can buy the boat the first thing and have it all the time we 're here."

"But *why* can't we stay?" wailed Mary.

"Oh, don't be so stupid!" exclaimed Dick, suddenly and scornfully, forgetting that he had asked the same question; "because it costs money, and we have n't got it—that 's why!" He dug into the sand savagely.

Mary's eyes filled with hurt tears, "You don't need to holler at me like that, Richard Clayton," she said with dignity.

"Oh, stop, Mary!" cried Phyllis Ellen, who felt that in a minute her own self-control would go. She was so worried about her mother and so tired from all the housework and waiting on her that she was nearly sick herself.

Dick, seeing her lips quivering, turned red and muttered apologetically: "Aw, cut it, Mary; I did n't mean anything. Here 's that pencil you wanted," and he handed her a stubby little yellow pencil.

This restored Mary's good humor, but unfortunately stirred up trouble in another quarter.

"It's no fair, Dick!" cried Anne; "you've got to give me a pencil too. You've got a lot—gimme that red one! Make him give it to me, Phil—it's no fair to give Mary one and not me, is it, Phil?"

This was too much for Dick, and he was about to refuse emphatically when Phyllis Ellen cried sadly, "Oh, Anne, how *can* you fuss about a pencil when Mother is so ill and—everything is so hard!"

At this Dick hastily brought out another pencil and handed it over to Anne, who took it, saying defiantly, "Well, I don't care; he ought to treat me just the same as Mary, if she is two years older!"

"Baby!" muttered Dick angrily, under his breath.

"Is Mother very sick?" asked Mary, anxiously.

"Yes, the doctor wants her to stay here a month longer. But I don't see how we're going to because we can't pay for the rent of the cottage after the end of this week."

Suddenly Terry sat up excitedly. "Say, Phil, let's give Mother the money in the Buried Treasure. We can save up some more this winter!"

"Oh, Terry, it was sweet of you to think of it!" exclaimed Phyllis Ellen, putting her arm around him and drawing him to her. She bent and kissed the back of his neck—it seemed to her such a short time since he was a chubby, huggable baby! Terry wriggled, though he did not object.

"But I'm afraid," went on Phyllis Ellen, "it would n't be enough to pay the rent for even one week."

"Is the rent a whole lot?" asked Terry, in surprise; "we've got a lot in the hide-y hole, Phil!"

"The rent for a month more would be forty dollars."

"Whew!" whistled Terry, much impressed by the sound of this enormous sum.

"How much have we got in the hide-y hole?" asked Mary.

"About four dollars, I think," answered Dick.

It was a subdued little group that straggled back up the beach to the cottage again.

The next morning, as Phyllis Ellen was getting wood from the shed, she overheard talking just outside. Through the thin walls she could easily make out Mary's and Anne's voices.

"Well, I think," said Mary, "that we ought to give Mother the Buried Treasure money anyhow."

"But if it won't pay the rent," argued Anne, "it's not much good. Seems to me we might as well keep it toward the rowboat."

"It might help pay the doctor," insisted Mary.

"But it took so long to save it up! Maybe we would n't get enough for the boat next summer, and we do want it awfully," returned Anne, dismally.

"Even if we do, I think we ought to give the money to Mother."

"Oh, well," yielded Anne, plainly reluctant, "let's see what Dick says to do."

But Terry must have joined his sisters at this point, for Phyllis Ellen heard his voice. "Say, kids, I bet there's more than four dollars in the hide-y hole—there was heaps and heaps of quarters and dimes last time we looked. Maybe there'll be enough for one week's rent. I'll bet if we asked old Mr. Brown, he'd give us the rent cheaper. He took me out in his motor-boat once—I just soon ask him."

Phyllis Ellen, standing in the dim corner by the wood-bin, smiled sadly to herself. "Poor Terry!" she thought; "they're so good about giving up the rowboat money that it's a shame there is n't more of it. Oh, dear, what ever shall we do?"

That afternoon, as Phyllis Ellen was hanging out the dish-towels, Terry burst in upon her, "Say, Phil, can we have some gingerbread, me an' Anne an' Mary? We're going to get the Buried Treasure and give it to Mother."

"Of course you can have some, Terrykins," answered Phyllis Ellen, as she cut three shiny brown squares.

"It's an awful *long* walk up there and it makes you awful hungry," remarked Terry, eyeing the rest of the gingerbread.

Phyllis Ellen could not help laughing. "You rascal! I suppose you want *two* pieces?"

Terry nodded violently, and there was an angelic grin on his rosy face as he watched her cut three more squares.

About an hour later, Phyllis Ellen and Dick sat on the steps of the front piazza. They had been talking over the situation again, trying to think up some plan to solve their trouble. But nothing seemed to offer itself, and always it came back again to the same point—only money could help them now, and there *was* no money!



Finally, they sat in hopeless silence. With unhappy eyes, Phyllis Ellen glanced down the sunny beach at the big blue ocean which sent in those cool, health-giving breezes her sick mother needed so badly. Suddenly she sat up and said: "Look, Dick, there come Mary and Anne and Terry. I did n't expect them so soon. They must have hurried dreadfully!"

"Gee, they 're waving like mad! Wonder what 's up; they act sort of crazy," said Dick, eyeing them curiously.

When they came up, Mary and Anne and Terry dropped down on the porch, looking hot and tired and out of breath, but they all three began to talk at the same time in a great state of excitement!

"Let me tell, let me tell!" clamored Terry; "it was me that said to go and get the money—"

"No, I 'm the oldest—it 's my place—" cried Mary.

"That 's no fair. I 'm going to tell. You two could n't find the Hide-y Hole again and I did"; this from Anne.

"What in the world has happened?" demanded Phyllis, bewildered; "tell us quick!"

"Here, cut out the squabbling and get down to brass tacks," added Dick.

"Well, here, look, take it, Phil," exclaimed Mary; "look what we found in the Hide-y Hole!" and she held out the old leather purse and the paper which had been in the tin box.

When Phyllis Ellen opened the purse and saw the bills, she turned white. Dick whistled as he always did when he was particularly moved or excited.

"But where did it come from?" cried Phyllis Ellen, completely at sea, "all that money?"

"Count it," urged Anne and Mary and Terry in chorus; "there 's a terrible lot!"

"Wow!" exclaimed Dick, taking the money and examining it; "here 's a twenty-dollar bill and tens and fives—wow!"

"Read the paper, Phil—it 's our money!"

And in a whirl of excitement Phyllis Ellen read: "A contribution to the Buried Treasure Fund, from Some One who used to play here years ago and who made Hide-y Holes with prickly plants over them too."

"Oh, my, who do you suppose it was?" she exclaimed.

"Phil, there 's eighty-five dollars here!" said Dick, in an awed voice; "must have been some one awfully rich!"

"Oh, let 's go and tell Mother quick!" and

in a moment all five were rushing into the cottage.

Mrs. Clayton was as much surprised and excited as the children.

"Oh, Mother, is n't it wonderful? Now we can stay another month!" cried Phyllis Ellen, her eyes shining with happiness as she bent over and kissed her.

Mrs. Clayton looked at the eager group of children, and her eyes filled with happy tears. "You blessed children! But I wonder—can we accept such a sum of money from a perfect stranger?" she said, looking worried.

"Well, you can't give it back, 'cause you don't know who it was," cried Dick, triumphantly; "and we 're not stealing it or finding lost money, 'cause it says on the paper it 's for us!"

"Oh, yes, Mother, you *must* take it," urged Phyllis Ellen, anxiously; "you need it so. Oh, I 'm so glad we have it!"

There really seemed nothing else to do, and great was the rejoicing in the little cottage.

"What was this Hide-y Hole for, dear?" asked Mrs. Clayton.

"Why, we were all saving money to buy Tim Dugan's rowboat. He said he would sell it to us for ten dollars, and it is perfectly good and does n't leak," explained Phyllis Ellen; "and then the children decided to give *you* the money instead. And so they went to get it to-day. Oh, are n't you glad they did?"

"You darlings! That was sweet of you and Mother loves you for being so thoughtful and unselfish," said Mrs. Clayton.

Anne turned red. She had not given up the Buried Treasure Fund so readily as the others, and now she wished she had.

"But, my dears, there 's so much more than enough for the rent," continued Mrs. Clayton, "do go and buy the rowboat right away. You deserve it as quick as you can get it!"

Dick was therefore entrusted with one of the magic ten-dollar bills, and the next minute all four went tumbling down the stairs and out of the house.

When they were gone, Mrs. Clayton examined the paper more carefully.

"That writing somehow reminds me of some one I used to know," she said to Phyllis Ellen; "it looks like the writing of a girl who used to be my best friend. We played together down here years ago—and then she went away, out West, and traveled, and after a while I did n't hear from her

any more. I think she married a wealthy Westerner. You 're named after her, Phyllis Ellen."

"Perhaps *she* is the one who put the money in the Hide-y Hole!" exclaimed Phyllis Ellen.

"I don't care *what* Mary and Anne say," he muttered under his breath, as he trudged through the sand; "don't see *who* coulda put all that money in the Hide-y Hole 'less it *was* a fairy—or something like that! An'



"'WONDER WHAT 'S UP; THEY ACT SORT OF CRAZY,' SAID DICK, EYEING THEM CURIOUSLY"

"Perhaps she did," said her mother, "it would be like her, I think. But I wish whoever it was could know what happiness it has brought us!"

Two weeks later, on a sunny afternoon, Terry slipped away from the cottage and hurried up the beach alone. He had an important errand, and he did not want any of the rest of the family to stop him.

maybe there 'll be some more there. Anyhow, I guess I 'll go and look if I want to."

But when he reached the Hide-y Hole and took out the tin box, it was still empty as they had left it after they found the unexpected treasure.

"Well," exclaimed a pleasant voice close by, "hullo! Won't you tell me what your name is?"

Terry jumped and glanced up hastily.



He had been so absorbed in looking for the Buried Treasure box that he had not seen or heard the approach of the beautiful lady who spoke to him.

"I'm Terry Clayton," he answered shyly.

show it to me, Terry? And may I go and see your mother and Phyllis Ellen and all the others?" asked the strange lady.

"Sure, just come along with me," replied Terry, as he started homeward briskly.



"WON'T YOU TELL ME WHAT YOUR NAME IS?"

"Oh, is n't that lovely!" cried the beautiful lady, smiling at him happily; "tell me quick! Did you buy the rowboat?"

"Yep," answered Terry, eagerly, his blue eyes shining with excitement; "an' we've got her all painted white just like new!"

"I'd love to see that rowboat! Will you

Mrs. Clayton was lying in the hammock on the piazza, reflecting thankfully upon how much better her health had become in the last two weeks, when Terry arrived with his new friend. She started up in amazement and cried, "Why, Phyllis Ellen Brown!"

"Mary!" cried the other, joyfully; "I'm so glad to find you again! But my name is Phyllis Ellen Thayer now. And you're not Mary Allen,—are you? —but Mrs. Clayton!"

"Then it was you who put the money in the Hide-y Hole! I suspected as much. Terry darling, run and find the others and ask them to come here." She turned again to her newly-found friend, "But how did you ever happen—"

"Oh, my dear, it was just one of those lucky chances! I came back East a few weeks ago, and I was driving around while my husband was away on business. I drove down here first thing to have a look at our old playground and just stumbled on the Hide-y Hole. I did n't even know you were here. Were these lovely children of yours surprised? It was such fun!"

"It was simply wonderful—a miracle! But, Phyllis Ellen, I can't take all that money from you," protested Mrs. Clayton, in distress; "we used it to stay here a little longer, because the doctor said I needed it. The blessed children were going to give me

their few precious pennies to help pay the rent for another month, bless their generous hearts! But—"

"Don't say anything more," interrupted the beautiful grown-up Phyllis Ellen, "the money meant nothing to me. And think what it would have been to us when we were little to have anything exciting like that happen! Let me have this little pleasure—I have n't any children. I want a share in yours. Please!"

"I named my first little daughter for you," said Mrs. Clayton, half shyly. "Oh, here they come now. Children, this is the good fairy who found your Hide-y Hole. And

what do you think? I used to play with her when we were little, and her name is Phyllis Ellen!"

"I found her!" shouted Terry, triumphantly.

"But I 'm named after her," said Phyllis Ellen.

"Well, it was *our* Hide-y Hole too," clamored Mary and Anne, "so she 's just as much *our* good fairy!"

"You darlings!" exclaimed the good fairy, happily; "I 'm going to belong to every one of you. And we 're going to start right away to have the best times in the world together!"

---

## SPLASH!

By GEORGE H. CORSAN

Swimming Instructor, International Committee, Y. M. C. A.

THE beach is the best place to learn to swim. The hot sun shines down; the strip of clean sand contains the little treasures all young folks love to find, and the water is warm and clear. But best of all, the land shelves gradually, and inshore the water is very shallow.

However, we can't all go to a beach,—sometimes they are too far away,—but there is usually a small creek or stream in the neighborhood which can be used instead. When a small creek is used for swimming, it is generally necessary, certainly wiser, to build a shallow pool in it, so that the water is running in and out continuously. This is not an expensive operation if the entire community gets out and works. The water in the creek must, of course, be kept clean.

In the larger cities, it is not so easy to have outdoor swimming-places, but every playground should have a shallow swimming-pool instead of the occasional small wading-pond.

The indoor swimming-pool, whether in the public school or high school, in the Y. M. C. A. or Y. W. C. A., should always have warm, clean water and a sufficient supply of fresh air. It should be shallow; these pools are always built much deeper than is necessary. For very small children, the indoor pool should be two feet from bottom to scum-trough; for high-school children, the pool should not be over three and a half feet deep.

For diving, there could be a spoon-shaped hole of sufficient depth, seven and a half feet, at one end. There must be no sudden drops in depth and the pitch of the floor must not be too steep. Out of doors, small children should have their first lessons in water a foot deep.

And if none of these places is available, a very small child can have its first swimming lessons at home—in the bath-tub. He can be taught to submerge his face and open his eyes; to breathe correctly; to scull; to do the flutter kick and the steamboat; and, lastly, to dog-paddle.

When children will learn to swim depends, of course, upon the child. Some children can begin when they are three or four years old, while others will not be able to acquire the art of swimming until they are ten or twelve. But as a general rule most children should know how to swim when they reach the eighth year. They should have learned the side and back strokes by their ninth year, and should have correctly acquired the crawl strokes by the time they are eleven years old.

When children learn to swim just as they learn to walk, to speak, to read and write, every one will be "drown-proof." They will also be strong and healthy, for frequent swimming is one of the best exercises for physical improvement. There is no better exercise—except esthetic dancing, which is



almost as good—for ensuring a beautiful symmetry of body.

Some children are at home in the water from their first lessons; they have no fear at all. It is a very dangerous thing to frighten children at any time, but it is particularly dangerous to frighten them when they are in the water. When a child shows fear of the water, don't let him grow up without over-



THIS BOY IS LEARNING THE CRAWL STROKE  
IN SHALLOW WATER

coming that fear. But don't try to coerce or force him to overcome it. If he is a small child, there are all kinds of toys that float in the water; and with a little thought, many water games may be invented. Get a child who is afraid accustomed to the water gradually. If the child is eleven or thirteen years old, it is a matter of time and great patience. I have had youngsters (not to mention grown-up men) who were so afraid of the water that the first lesson consisted in wetting the toes; the next day, the ankles went in; and so on, until they could swim up and down the pool.

Swimming has three principle divisions: rhythmic breathing; maintaining the correct angle of the body; and using correct movements. Each division consists of many details. Children, as well as grown-ups, should learn only one detail at a time. Each detail should be well done before the next is begun.

When a child enters the water he wades in. Even in wading, there is a right and a wrong way. The arms must extend downward, slightly in front. The hands are held open, with the palms facing the water. In this way, the wader is able to push himself back if he steps unexpectedly into a hole. The

arms must not be held up, away from the water, and they must never be extended over the head.

Reaching water a foot deep, the child should lie down in the water on his back, head inshore. He should place his hands flat on the bottom. The body should be held straight, but the child, at first, will bend his body, thus holding the top of the head up instead of down. To keep the body straight, the hips should be up, the top of the head should be held down. The mouth and nose will thus be above water. If the child can't do this easily, he should assume the same position in water just eight inches deep. Here, he can rest the top of his head on the bottom, submerging his ears. In this depth he will gradually relax the muscles of the neck.

Coming back to the deeper water, the child will learn to breathe correctly. Rhythmic breathing is the basic principle of the art of swimming. The child should lie face downward, hands flat on the bottom, supporting the body easily at the surface. In turning from the position on the back to that on the front, one hand should be kept on the bottom. Open the mouth and take a deep breath of air. Then close the mouth and lower the head until the face is under water. Breathe out through the nose, while the face is submerged. The air will make little bubbles as it rises to the surface.

Now that the air is out of the lungs, it is necessary that the child raise his head above water to get more air. To do this, the head should not be lifted up out of the water as though it were the lid of a trunk. A hinged lid can be moved in only one direction—up and down. But the head can be turned partly around, from one side to the other—that is, from shoulder to shoulder. This is a rotary action or movement. Therefore, to breathe in again through the mouth, turn or swing the head so that the top of the head is turned down toward the water, and the mouth and chin are turned up. This will bring the mouth above the surface of the water. Then open the mouth, take in a gulp of air; close the mouth; turn the head by the same rotary movement so that the face is under water again, and breathe out under the water, through the nose. This breathing exercise should be practised until it can be done quite easily, without effort.

If the child is learning in a pool, where the water is not so shallow, he will have to learn correct breathing in the perpendicular position, instead of the horizontal. He will

stand up and take in a deep breath of air through the mouth. Then he will close the mouth and submerge his head by "squatting," that is, bending the knees out until the water has covered his head. The body is not bent at all. Breathe out under water through the nose. The feet must always be placed firmly on the bottom of the pool.

The eyes should be kept open above the water. They should be closed just at the surface and opened again under water. This will require a little practice.

To learn the flutter or crawl kick, one will lie face downward, with his hands flat on the bottom. (If in a pool, he can grasp the edge.) The flutter or crawl kick is just what its name indicates: a flutter or thrash of the legs. It is a short snap of the feet together while the legs are held straight. The ankles are held at full extension and are not moved. The knees should limp slightly, then stiffen. The leg muscles must not be tense. The action or swing is from the hip, not from the knee. The water should "boil" at the feet. After learning the flutter kick face downward, turn



A HOME-MADE SWIMMING POOL. THESE THREE YOUNGSTERS TOOK LESSONS IN IT

over on the back and do it upside down. This kick is an up strike on the front and a down blow or thrash on the back. It is much easier to do it on the back than on the front.

After learning the flutter kick, one should learn to scull. Sculling is a very important detail of swimming, and one which, in teaching the art of swimming, is generally neglected. It is the method to use in an emergency, such as cramps, or if the swimmer is tired and desires to rest as he moves through the water. Although of so much importance, it is really one of the easiest details to learn, and it does not require much

energy. The child lies flat on his back. The top of the head is thrown back; the chin and hips are up. The legs are straight stretched and together. The movement is by the arms only. The arms are extended along the body. The wrists are immovable. The child propels himself by shoulder and arm-muscle action only. The hands are worked with a twist and a push at the same time, as a gondolier does a paddle, or as one does in sharpening two knives. The movements are in and out, the hands working together. Sculling may be done either head first or feet first. To go head first, keep the heels of the hands down and the tips of the fingers up. To go feet first, keep the tips of the fingers down and work the hands by a rapid motion underneath the hips.

To do the "steamboat" on the back, do the flutter kick and sculling together. There is no coordination between the leg and arm actions; but both actions are short and snappy.

The racer's plunge, or skimmer dive, should be learned next, so that one will learn to enter the water properly. To do this dive, lean down toward the water as the children do in the illustration on page 1030. The knees are bent. The toes grip the edge of the pool. The hands are extended beyond the head. The water should be only a few inches below the take-off. The spring is made just when the balance is lost. The dive is long, flat, horizontal.

Do not forget that all these lessons are to be in shallow water. A giant could learn to swim in water three and a half feet deep.

I do not use water-wings, as a general rule, until after this fear-elimination drill. They should not be used in the attempt to overcome the feeling of fear. But I do use them for acquiring perfection in swimming; they are of very great assistance in learning rhythm and detail; and it is possible, with their use, to learn to swim much more quickly and correctly. When one detail—that is, correct leg or arm action—has been acquired, work at the coordination of both leg and arm action so that all four limbs work together correctly. Even small children will soon find that water-wings will impede their progress through the water, and will discard them when they have correctly acquired the complete stroke.

Now comes the front crawl stroke, which is one of the most technically difficult strokes to learn. The arm action, however, can be studied to perfection in a land drill, just



as wand and club drills are done in the gymnasium.

The land drill: Heels together, with feet at an angle of 45°. Knees stiff. Lean forward

forward is always higher than the one moving backward.

The right shoulder is depressed. The left shoulder is elevated. The face is turned to

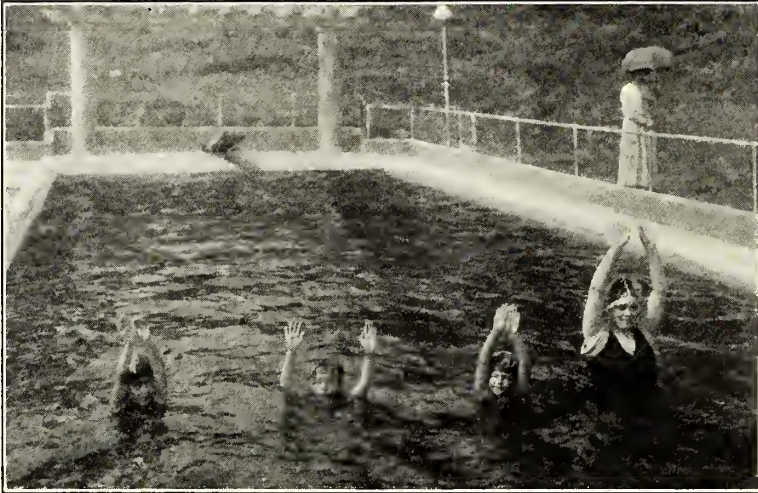

TEACHING CHILDREN TO BE AT HOME IN THE WATER. FIRST LESSON: BREATHING IN THROUGH THE MOUTH, ABOVE THE WATER—TIME, ONE SECOND

to an imaginary water-level. The back is hollowed, the chest is thrown out. In all the motions, the elbow must be out from the ribs. The palm of the hand must face rear-

the left. The top of the head is bent down toward the water, the mouth is turned up. The right arm presses to the rear. The left arm swings forward. The left hand trails

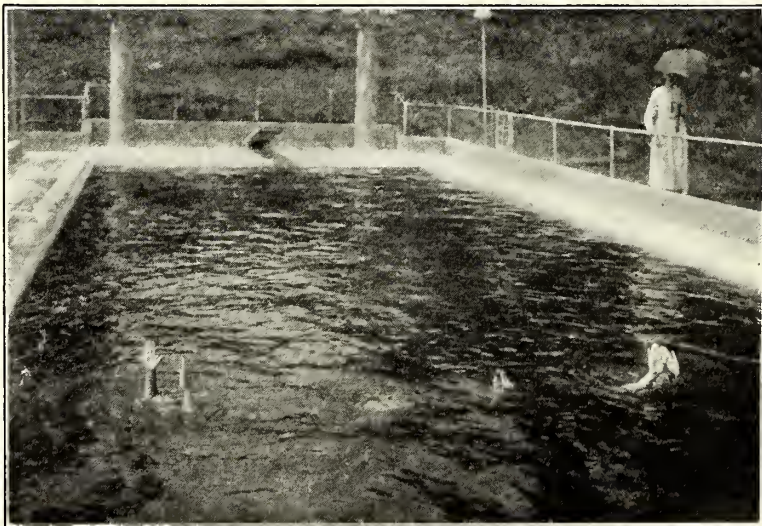

SECOND LESSON: BREATHING OUT BELOW THE SURFACE OF THE WATER, THROUGH THE NOSE, WITH MOUTH CLOSED. TIME, TEN SECONDS

ward. The hands are flat and firm. The motions are continuous. All pressure is to the rear, *not* to the front. The arms move regularly and continuously and rather like a windmill, though slower. The arm moving

behind the elbow. The left elbow advances before the hand. The left shoulder is heaved up still higher. The left arm is relaxed as it swings forward.

At the same time, the right hand is moved

rearward with a strong shoulder pressure. The right elbow is fixed and firm, and is out from the ribs.

When the left hand and elbow are in line with the shoulders, and are relaxed, the right hand is almost at the finish of the rearward pressure. At this point, the pressure is accelerated; then the arm swings forward perfectly relaxed.

The head is straight; the face looks downward. The shoulders are level. The left wrist is strongly hooked. The left hand reaches far forward to the left.

The face is turned to the right. The left shoulder is depressed, the left arm firm and the elbow out from the ribs. The left hand is moved rearward with a strong shoulder pressure.

At the same time, the right shoulder is elevated. The right arm swings forward in the same way the left arm did in the first action.

When the beginner swims the front crawl stroke, he will turn his face to right and left alternately, that is, toward the arm coming up out of the water. He will breathe in on one side only, and breathe out as he turns his head to the other side and on the return. But when he becomes an expert crawl swimmer, he will turn his face to one side only and will breathe out under the water.

In the crawl stroke, the propelling power is the shoulder muscles. The action of the arms is rather like the double-bladed paddle used by canoeists. The swimmer reaches far forward with one arm to dip it in the water, while the other arm pushes the water back as it moves backward. The hand hits the water edgewise, and is held so that the thumb is on the downward side. The "dip-in" is quiet. The flutter kick is used with the front crawl, but the arm and leg actions do not coordinate, although the arm action coordinates with the breathing. The position of the head is important. The swimmer must not look ahead, as, in doing so, his body will be thrown on an incorrect angle. He may look up or sidewise, look back or down, but he must never look ahead.

Children should not learn the old-fashioned breast-stroke. It is much better for them to learn the other strokes only. The breast-stroke is a very awkward motion and really handicaps a child when he begins to learn the other strokes.

After the front crawl is acquired, the side underarm stroke should be learned. In this stroke, the upper hand is kept close to the

body on the thrust back as well as on the recovery. The hand, when it reaches the upper thigh on the thrust back, is held there a moment at rest. The lower hand makes a long, deep sweep, far under and back. The scissors kick is used with the side underarm stroke and is made when the upper arm is shoved back and the under arm is thrust forward. The legs recover for the next kick as the under arm makes the pull, and the upper arm feathers forward in its recovery for the next drive. When the kick is finished, there is a decided pause.

To do the scissors kick, the upper leg is



THE AUTHOR DEMONSTRATES THE DIFFICULT FEATURE OF THE CRAWL ARM ACTION

held almost straight. The foot is pointed. The under leg is thrown far back and the top of the foot strikes the water a hard blow. The under leg should not be jerked back. It should be thrown slowly. There should be a distinct pause when the under leg has snapped forward to the upper leg, while the swimmer glides through the water. This kick should be learned on both sides, that is, on the right side and on the left side. The scissors kick is used in the trudgeon, the side underarm, and the English overarm.

The action of the frog kick is entirely different from the scissors and crawl kicks. In the frog kick, the knees are drawn apart; in the other kicks, the knees are more together, as the kicks require a rather knock-kneed position. These kicks should be learned before the frog kick, which should be used only with the double-over-arm-on-back and the broad-stroke-on-back. The feet should not be jerked apart. They should be drawn up easily and brought together with a snap. There is a pause before repeating.



Any kick can be used with the back crawl or racing-stroke-on-back (which is really an alternate overarm stroke)—the crawl or flutter kick, the scissors kick, and the frog kick. For the arm action: while one arm, under the water, is pushing the water back, the other arm is raised out of the water over the head. The arm should be taken out of the water gently. To prevent water falling on the face, when the hand has reached the thigh, after finishing the stroke, that shoulder should be shrugged and the arm heaved on the body. Then the arm is swung in the air over to the other side of the body. The same

ming around quietly to see just where the rocks and snags, if there happen to be any, are located.

The dive should be taken about two feet above water-level. The eyes should be fixed on the water several feet distant. For the first dives, it will help to imagine that there is a hurdle or pole just in front of the spring-board, which has to be cleared. Enter the water head first to avoid a flat dive, that is, landing on the stomach. The arms should be extended to protect the head. After a dive, to come up quickly, throw the head back when in the water. The head is

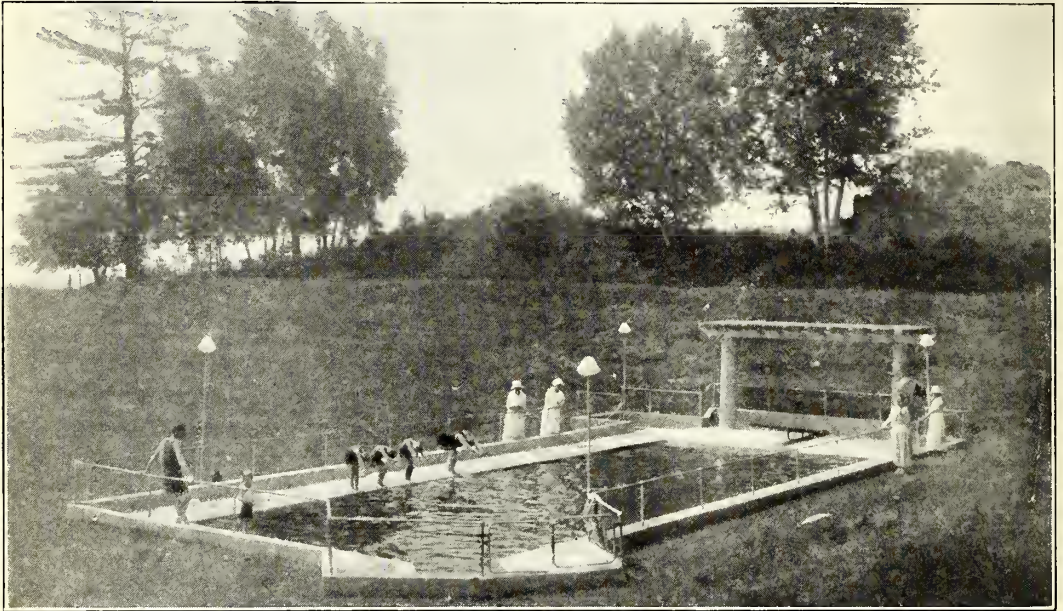

IN THIS PICTURE A MOTHER IS TEACHING HER CHILDREN THEIR FIRST DIVING LESSON, THE RACER'S PLUNGE. THEY LEAN DOWN CLOSE TO THE WATER

muscles are used in the back crawl as in the front crawl.

Other back strokes are: the single overarm, the double alternating overarm, the broad stroke, and the double overarm.

The trudgeon stroke, which is an alternate overarm, is a front stroke and is done with the scissors kick. The arm motion is the same as that of the front crawl.

Besides the racer's plunge, which is learned in the first swimming lessons, the only other dives that may be done by children under ten years old are the standing back dive and the plain or neat dive.

Whether the diver is a small child just learning or a grown-up, he should always be careful when diving in strange places. He should examine the water thoroughly, swim-

the heaviest part of the body, and the body always follows the head.

For the neat or plain dive, stand erect on the board. The hands should hang at the sides. The toes are just over the edge of the board. Lose balance by leaning forward to an angle of  $45^\circ$ . Throw the head down and the feet up. The hands should meet straight above the head. They serve as a rudder, and the palms must not be held together in entering the water. The backs of the hands must be up and the palms must face downward. The forefingers and the thumbs must be together. The course of the body is determined by the tips of the fingers. If they are straight, the body will keep the angle at which it entered the water. The course will be downward if they are turned



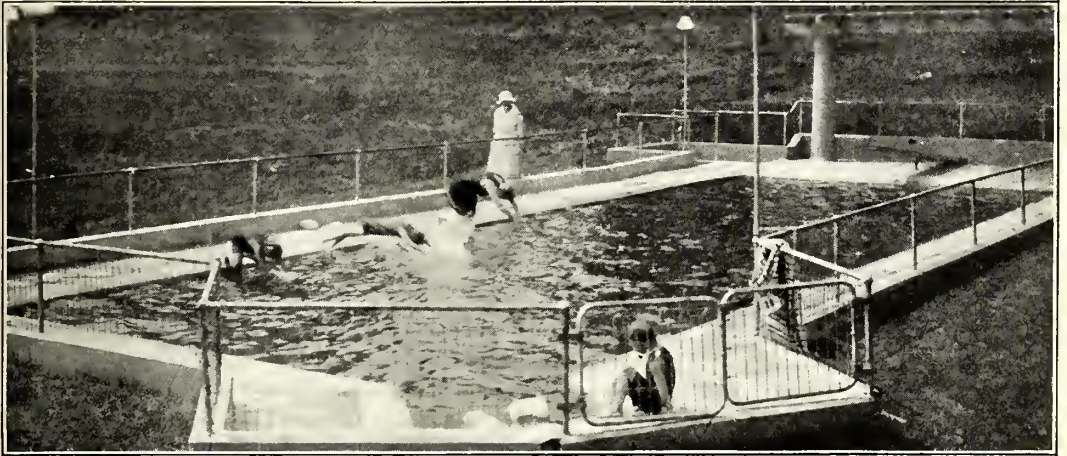

IN THIS SECOND DIVING PICTURE, THE CHILDREN HAVE LOST THEIR BALANCE AND ARE TAKING THE HORIZONTAL SPRING FROM THE EDGE OF THE POOL

down; upward, toward the surface, if they are turned up.

The standing back dive may be done from water-level up to twelve feet, but it is much too dangerous to take it above that height. Naturally, for young people, it should be done nearer the water. The body must be well arched. The diver merely falls back, though he may spring off if he is very near water-level. The arms are extended above the head.

Four dives are always required at good swimming-meets: the standing back dive, the running swan, the running jack-knife, and the back jack-knife. They are all done from the low spring-board.

It is not necessary to teach children individually. They can be taught by the

massed system, the same as adults. I have taught as many as one hundred boys at a time, but they all require different handling. Some are bashful and must not be noticed at first; some are so unruly they must be suspended until the next lesson. But most of them come in between these extremes. The instructor must have the confidence of his pupils. He must always speak cheerfully to them and make the swimming lesson a game.

Now is the best time of the year to swim. Every boy and girl should learn to swim this summer, so that, when they reach the state of "grown-upness," they will be graceful and accomplished swimmers, and feel just as much at home in the water as they do when they are on land.

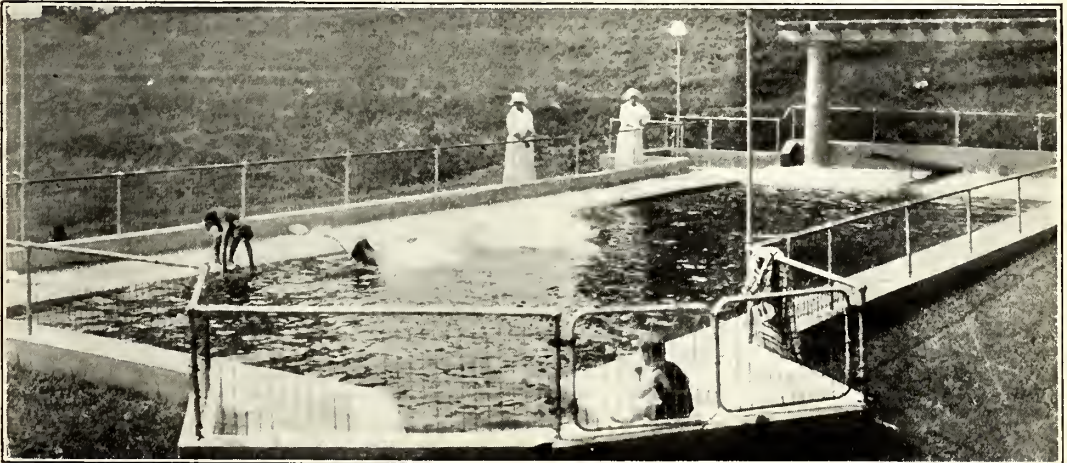

AND IN THIS PICTURE THEY SKIM ALONG THE SURFACE OF THE WATER. THIS IS AN EASY WAY IN WHICH TO BEGIN A DIVING LESSON





## DOWN AMONG THE WHARVES

By ELEANORE MYERS JEWETT

DOWN among the wharves—that 's the place I like to wander!  
Smell of tar and salted fish and barrels soaked in brine!  
Here and there a lobster-crate, and brown seines over yonder,  
And in among them, mending nets, an "old-salt" friend of mine.  
That old-salt friend of mine—how we love to talk together!  
Breathless is the wonder of his tales about the sea!  
His face is tanned and wrinkled by the roughest kind of weather,  
And he is like a hero in a story book to me!

Down among the wharves when a stiff north wind is flying,  
Schooners rub and bump against the docks they lie beside;  
Half-way up the masts, the billowed sails are pulled for drying;  
Hawsers all are straining at the turning of the tide.  
The turning of the tide! Time of wonder and of dreaming!  
Fishing-sloops are slipping from their docks across the way;  
How our wharf reëchoes when their saucy tugs are screaming!  
How the green piles whiten with the tossing of their spray!

Down along the wharves among a wonderland of shipping—  
Rows of shining, slender masts that sway against the sky!  
Every day at flood of tide we watch some schooner slipping  
Out among the circling gulls, my old-salt friend and I.  
My old-salt friend and I—he will drop the nets he 's mending,  
Watch with me each flapping jib, each straining yard and spar;  
How we thrill together when the sails are full and bending—  
We who like to wander where the waiting vessels are!





"DOWN ALONG THE WHARVES AMONG A WONDERLAND OF SHIPPING"



# THE MYSTERY AT NUMBER SIX

By AUGUSTA HUIELL SEAMAN

Author of "The Boarded-up House," "The Sapphire Signet," "The Dragon's Secret," etc.

## SYNOPSIS OF PREVIOUS INSTALMENTS

THE cousins Sydney and Bernice Conant made a curious discovery at the abandoned phosphate-mine pool known as Number Six, about twelve miles from their town of Jasper, in South Florida. They find an apparently deserted old farm-house at one side of the pool to be inhabited by an Indian guide of the Everglades, Jerry Sawgrass, his wife, a native "cracker" woman, and a young girl of the cousins' own age, understood to be Jerry's adopted daughter. About this girl there appears to be much mystery. She is kept away from every one, and there seems to be no explanation of her real relation to the two in the farm-house. She begs the two cousins to come to see her occasionally, as she is lonely, but asks that their visits shall not be known to Jerry and his wife. She says her name is Delight.

The cousins disagree radically in their discussions of the matter. Bernice feels there is some deep mystery about the girl, that she is not like the people she lives with, that perhaps they do not treat her kindly, that she wants to get away from them. Sydney thinks Bernice is mistaken, that the circumstances are not very much out of the ordinary. They decide, however, to investigate the mystery as far as possible. The following Saturday morning, they discover that Jerry and his wife have come to town to spend the day, leaving Delight alone at Number Six. They hurry out in the afternoon to see her, and, during this visit they learn from her that though she has spent virtually all her life in the heart of the Everglades, she has learned to read by attending school at the edge of the Glades for a few months, unknown to Jerry. Jerry and his wife are discovered returning unexpectedly early, and, at Delight's consternation, Bernice impulsively asks her whether she is afraid of her uncle. To her intense surprise, Delight declares she is very fond of him.

Three days later, through a conversation overheard by Bernice in the post-office between two unknown men, she learns that there is a new factor in the problem: that Jerry is evidently much disturbed over the discovery in town, the Saturday before, of a Mr. Tredwell, a lawyer from New York, who is staying at the same hotel where she and her parents are. Visiting the pool that same afternoon, they discover Delight, at some distance from her home, walking to the store, where she has been sent on an errand. She accepts their invitation to join them, and, during the ride, discloses to Bernice that the reason she had learned to read was because she had discovered something, long before, that she hoped would tell her about herself—who she really was.

## CHAPTER V

### REVELATION

AFTER it was all over, Bernice thought it the strangest afternoon she had ever spent; but at the time, her mind was so occupied with other things that she never realized how the hours went. Sydney drove them to the little roadside store, five miles away—a wee little place where the chief articles for sale seemed to be ginger-ale and other liquid commodities of a like nature. As in a dream, she watched Delight make her simple purchases, and then they started to drive back.

"But if I get back and go home so soon," commented Delight, "they'll wonder how it happened. It takes a long time to walk that ten miles. They'll not like it if they know I have ridden with you—with *any one!*"

"Oh, *that's* simple!" Sydney laughed; "we'll take a good long drive and land you back at home about the time you'd naturally arrive there. So much the better!"

"You just drive ahead, then, and don't pay any attention to us—we're talking!" commanded Bernice, in a significant tone. And Sydney, quick to take the hint, devoted himself exclusively to the wheel, while the

two girls, snuggled down in the back seat, remained oblivious of all outward affairs.

It was a long story that Delight told, partly in the "cracker" patois that she naturally used, partly in the simple, but labored, good English that she sometimes tried to affect. The substance of it, as Bernice later retailed it to Sydney, was as follows:

She had always lived in the Everglades, as far as she knew or could remember—in the very depths of them, for the greater part of the time. Whether she was born there or not, she did not know. She had always been with Jerry and his Indian wife, Wanetka. Wanetka had been very good to her, very kind and loving—in fact, both of them were. The first camp or home she remembered was on a "hammock," or wooded knoll, in the Glades near the region of Fort Myers; but even that town was many miles away, across the Big Cypress Swamp. Jerry used to go off for supplies, occasionally, in his canoe. He got Wanetka anything she wanted. He even brought her at one time a little hand-sewing-machine, and the Indian woman made pretty things with it for her to wear.

The girl declared that she was very happy at this period. She loved the wilds and knew

no other kind of life. Later, Jerry decided to go to another region, and they moved the camp to the north side of the Glades. There were many other moves, sometimes near the Miami region, sometimes on the West side. Always they kept well within the Glades. In the main, it was Jerry who went out to the towns, though occasionally Wanetka went. Jerry often acted as guide to some tourist who wanted to make a trip into the Glades. Sometimes it would be just for hunting or trapping, sometimes a man would take an exploring expedition through them. Jerry knew them as no one but the Indians knew them.

At this point, Bernice had inquired, without some trepidation, whether Jerry himself was partly Indian, as it had been rumored. Delight replied that he had once said he *thought* he was part Indian, but neither his father nor mother were Indians. They were both native Floridians from somewhere near Fort Myers. His real name was not Sawgrass, but Simpson. The former had been given him as a joke by the first person he ever guided through the Glades. These wilds are overgrown with the terrible sawgrass, its tall stalks having serrate edges as sharp as a knife. It is almost impossible to cut one's way through it. Jerry was so expert at overcoming this difficulty that the man had nicknamed him "Jerry Sawgrass" and he had kept the name to this day. But he had once been told that one of his grandparents was a Seminole Indian and he thought it was his Indian inheritance that made him love the Glades so much. He preferred to live in them and was very fond of his Indian wife. She was a real Seminole.

It was a long time before Delight ever thought of asking any questions about herself. She never dreamed there was anything to ask. Jerry and Wanetka were as father and mother to her. She had never known any other. And as she almost never saw any one else, there were no questions in her mind. She was happy—that was enough. But when she was about eleven or twelve years old a strange thing happened. They had just come to live near Fort Lauderdale and were camped on the New River several miles inland from the town. She had gone out one morning to roam in the woods, but came back after a while and lay down in the sun close to the back of the hut. She had almost fallen asleep when she heard the two talking inside the hut. They evidently thought she was still away, for as she listened, because

she had nothing else to do and could not very well avoid it, she heard Wanetka ask Jerry if she might take Delight to town with her next day. He replied, a trifle angrily:

"No, no, *no!* Now don't begin that! You know what the understanding was. She's not to go near people. It'll be the beginning of trouble. She's getting older now and'll begin to understand and ask questions. It won't do, I tell you! He gave strict orders and I won't have 'em disobeyed!"

Instant wonder sprang up in the mind of Delight. What was it all about? She could not imagine. She had never dreamed there was any mystery about herself. Who was it that did not wish her to see people? And why? She lay very still and listened, hoping she might hear something else. They were quiet a long time. Jerry was mending a fishing-rod and Wanetka was putting things away in the hut. She liked to keep it tidy. They had not been there very long and things were not in their right places yet. Presently she heard Wanetka ask Jerry, "Where shall I put this?"

"Here! give it to me," Delight heard him answer. "It's time that thing was destroyed. She might get hold of it sometime. She can't read, but it might make her curious. I'll burn it!" And then there was a sound of tearing, as if a book was being ripped to pieces. Nothing else happened and after a while they both went out to fish in the river farther upstream. Neither one had seen her. It was then that she stole into the hut and looked in the fireplace. The fire had gone out. There was quite a pile of ashes and the stiff covers of a book that had charred, but not burned up. On one of the covers was a word or two in printing. She did not know what it was. She had rarely seen any books and very few printed words—only those on the canned goods and things that Jerry brought home from the towns. But something in her mind told her it *meant* something—and she saved it. Then she poked around in the ashes and presently found several pieces of paper that had only been charred around the edges. And on these papers were strange marks, not much like the printing on the book-cover, and yet not entirely unlike them. She did not then know it was handwriting, but the same feeling made her sure that this too was something which, if she could find out what it meant, would help her to make something out of this strange new puzzle.

She took the papers,—all that had enough



left of them to be worth saving,—and hid them away in a safe, dry place, at a distance from the hut. She never spoke to them, of course, of what she had discovered, and they never knew. But from that moment, she felt that she could not rest till she had learned how to puzzle out all that was on those papers. She thought and thought of how it could be

nect with anything at all, and often made mistakes and got them connected with the wrong things. But she learned a little that way. Then, one time when Jerry and Wanetka had both gone into town, they came back with a magazine that Wanetka had bought because she liked to look at the pictures, and at the same time she had insisted



"HAND OVER THOSE PAPERS—QUICK! I WANT TO SEE WHAT WE CAN MAKE OF 'EM'" (SEE PAGE 1040)

done. Jerry would not allow her to go into town and go to school—she knew that without even asking. Neither he nor Wanetka knew how to read themselves. How was she to begin?

In looking about the house, she saw, however, that many things they had were labeled with marks, and guessed that those marks made words which told what the various things were. So she took the cans and boxes whose contents she knew and tried to memorize the marks upon them. Very soon she knew the combination of marks that meant tea, sugar, flour, and words of that sort. Many times she met with words she could not con-

on getting for Delight a book full of bright-colored pictures that she thought the girl would like to see. Because they could n't read, neither of them realized that this little book was a child's primer, the pictures showing what the simple words or sentences meant, so that one could n't help but learn something from it, especially if one were interested and trying hard, as Delight was.

After a while, she had learned all she could from the primer and she knew now quite a number of words whenever she saw them, but she never found any like those on the cover of the burned book, nor in the least like the marks on the paper or leaves. She was really

unhappy because she could make no more progress. About this time Jerry agreed to go as a guide with a man who wanted to spend several months in the Glades, apparently exploring or doing some scientific work. They were to be absent four or five months.

After he had gone, Delight paddled the canoe down toward the town one day, and discovered, on the bank of the river, just before reaching Fort Lauderdale, a little house where there seemed to be a number of children sitting in rows and learning some of the very words she had puzzled out by herself. She knew then that this was a *school*. She had sometimes heard Jerry speak of it as being near the town. A pretty young woman was sitting on a raised platform and telling the children the words. Delight never knew how she came to do it, but she suddenly got out of the canoe, walked right into the room and up to the young woman and asked if she could come to school there. The teacher looked rather surprised, but said, "Of course, dear! Sit down over there and I'll find out presently what you know."

She found out later that Delight knew very little, except the words she had taught herself, but was so anxious to learn that she picked up the lessons very quickly. The teacher did not ask her too many questions, for she thought the girl was one of the Indians who often came down the river to the town. Some of them would once in a while come to school for a time, and the white people were always very anxious to have them do so. They asked them few questions, for they had found that if they did, they would become scared, or perhaps ashamed and never come any more.

Delight went back to Wanetka that day and told her what she had done. Wanetka was very angry about it at first, but Delight begged so hard, saying that she wanted to learn to read so she could amuse herself and promising to read the interesting stories aloud, when she could do so, that finally Wanetka gave her permission and agreed not to tell Jerry. Only Wanetka made her promise faithfully that she would have nothing to do with the other children and would come straight back every day when school was over and would not tell the teacher anything about themselves or where they lived.

She attended school all the time Jerry was away, and in that time learned to read and write, though not very well, and a few other things. The teacher thought she learned with amazing quickness, but this was prob-

ably because she was determined to do all she could in the short time she could attend the school. The teacher used to give her extra instruction at recess-time, when she saw the girl did not play with the others out of doors. Sometimes she stayed after school was over and gave her further help. She even lent her some story-books of her own. She was very kind, and only once did she try to learn anything about her strange pupil. She put her arms about Delight one day and asked how was it that her eyes were so blue and added that she did not seem like an Indian. But when she saw that she was making the girl uncomfortable, she did not press the question, and never referred to it again.

Jerry came back at the expected time and Delight dared not go again to the school. She was sorry, but she had learned to read and write after a fashion, and was content. Not long after, Jerry came back from the town one day, seeming upset about something. He gave no explanation of his reasons, but in a day or two they had packed up all their things and were off for another home. They went far into the Glades this time and stayed there longer than ever before. It seemed almost as if Jerry was afraid to come out. At last, their supplies running low, they moved nearer to a town, going to the northern part near Okeechobee. It was here that Wanetka was taken ill. Jerry finally got a doctor, but he came too late. She died in a few days and they buried her there near the Lake.

It was plainly an effort for Delight to go over this part of her history and she stopped for a few moments to wink away the tears. But presently she went on. "We felt very bad and very lonely after that—Uncle Jerry and I. He's never been the same. He never talked very much, but since then he's been so quiet—he hardly ever speaks at all, only when he's spoken to or asked a question and must answer. Very soon after we went to a Seminole encampment and stayed with the Indians.

"Then, a few months ago, he began to be ill, and he thought the Glades did n't agree with him any more—that he would never be well again while he lived in them. He went and saw some of his own people that he had n't seen for years. He went several times, just for part of a day, but he did n't take me with him. At last, one day he came back and told me he had married again—a cracker woman he had met while



he was visiting his people. He said she 'd be good to me and help take care of me, and that we were going to go further north to live, away from the Glades altogether.

"So we came up here. It 's a queer change and I miss the Glades very much. Uncle Jerry found he could rent that old house, 'way off from everything, and it just suited him. He thought no one would know him around here, but I think he 's mistaken about that.

"He 's been recognized several times. It has upset him. The—his new wife is—kind enough to me but, somehow, I can't like her very much. She 's not tidy about things, like Wanetka, and she never wants to move about much. She 's not unkind to me but—but I think she does n't care *very* much about me—and I can't seem to care for her. They don't wish me to see any one or—or go anywhere. To-day is unusual—that I should be allowed to go for these things. It is only because Uncle Jerry could n't go—and she *would n't*. That 's all!"

She ended the tale so suddenly that Bernice was quite startled. "But, Delight!" she exclaimed, "you have not told me what you found out about those papers you were so anxious to read! Did they tell you anything? What was it?"

"They told me something, but there was n't enough, there 's so much I could n't understand," the girl answered. "They only puzzled me—more. Here they are. I always carry them about with me—hidden. You may look at them for yourself." And she took a small packet from inside her blouse and thrust it into her companion's hands.

## CHAPTER VI

### CHARRED PAGES

BERNICE looked at it with curiosity and awe. Never before had she been so close to a mystery. With fingers that shook a little from excitement, she unfolded the wrappings and brought to light several discolored pages, looking as though they had been torn from a fair-sized note-book. All around their edges they were blackened and charred by fire, so far in that often words were indistinguishable. And they were covered with fine and precise handwriting, still legible where the fire had not touched it. Bernice was wildly impatient to examine them more closely, but the wind caused by the speed of the car blew them about and made the task almost impossible. Further than that, Sydney

warned them that it was about time that Delight should be set down near her home.

"I am going to beg a great favor," said Bernice, taking a sudden determination. "Will you allow us, Delight, to take these papers home with us and examine them at our leisure to-night? Perhaps we may be able to make something out of them that even you have not. We will keep them just as safely as you would, and will return them to you to-morrow."

"You promise that you won't show them to *any one*?" questioned the girl, in hesitation. "I feel, somehow, I ought n't to—to share this secret with any one. But I trust *you* so much—"

"You can depend upon us, Delight," Bernice assured her. "I have never broken a promise yet!"

"Then—take them!" and Delight thrust them into her hands again. "If you 'll meet me to-morrow afternoon—near the largest palmetto clump across the pool from the house, I 'll be there." As they neared the opening to the trail that led to the pool, Delight asked them to leave her there and she would walk the rest of the way. "I 'd feel safer that way," she said and added: "Oh, there 's one thing more I forgot to tell you, Bernice. The word on the cover of the book—I could n't keep the thing. It was too big—and hard. I was afraid it would be found. But I remembered the word. It was 'J-O-U-R-N-A-L.' I 'm not very sure I know what it means. But, good-by! I must n't stay another minute!" And she hurried down the trail.

"Drive home like the wind, Syd!" commanded Bernice, when she was out of sight. "I 've so much to tell you that I 'm just about bursting—and I can't do it till we can be quiet somewhere!"

When they got to the hotel, Sydney suggested going on to his bungalow for the proposed confab, but Bernice voted against this. She knew that her mother was visiting his mother that day and that they would have difficulty finding a place where they could be undisturbed. Then Sydney suggested a live-oak grove half a mile down the road. But Bernice voted that down also. "It will be hot there," she decided, "and there 's no comfortable place to sit. Let 's just get rocking-chairs and sit in the east corner of the hotel veranda. It 's nice and shady there, with a good breeze, and absolutely no one about at this time of day."





"IF YOU WANT TO SEE SOMETHING STRANGE, COME WITH ME!" (SEE PAGE 1041)



And this they did. Before examining the papers, Bernice retailed to her cousin every word she could remember of the long account Delight had given her of her past history. Sydney listened with absorbed attention, but without interruption till she was through.

"My word! but that 's *some* earful!" he exclaimed slangily, but in deadly earnest, nevertheless. "Hand over those papers—quick! I want to see what we can make of 'em. Guess you were right, old girl—there sure is some mystery here!"

Again Bernice undid the packet of charred papers. "Delight said the book-cover that she destroyed had the word Journal on it, so it 's not difficult to guess what these must be," she commented, before they proceeded to examine them critically.

Then, with bated breath, they gave themselves to the study of the scorched sheets. After a long interval, Bernice looked up, an expression of blank dismay in her gray eyes.

"But, Syd, what does this all *mean*? I can't make head or tail out of it! Look here,—for instance. It reads,—Air roots of *ficus aurea* become fused together when remain pressed in contact. Cases of natural inarching very unusual. *Coccolobis floridana* in abundance on this hammock. . . . Ground in this region probably lifted after great Pleistocene subsidence. . . . The *Bursera* and some of the *Eugeni*as are second migrants. . . . I just can't make anything out of it at all!"

"I know," agreed her cousin, "it *is* pretty confusing, but I 'm beginning to think I see daylight. Somebody has evidently been making notes, naturalist's or geologist's or botanist's notes about something, somewhere—probably in the Glades, by the look of it. I don't wonder the poor kid was rather mixed up by all this. Naturally, she could n't understand a word of it—just like so much Greek to any one who has n't studied that sort of thing!"

"But do you suppose it 's *all* just—this?" cried Bernice, disgustedly. "What 's the use of wading through it? There are quite a number of pages."

"You can't tell about that. If it were a journal, perhaps there might be some other entries—more personal ones. And if that 's the case, we can't afford to miss them. They *might* explain something, you know."

"Well, let 's look 'em all through, then!" sighed Bernice, resignedly. "We can skip lightly over the—the scientific parts. Here, you take that bunch and I 'll go over this one.

If we don't come across something in that way, I give it up."

They settled down to quiet and silent study of the closely written and now all but illegible notes. Suddenly Bernice sat up with a start.

"Look here! see what I came across—right in with a lot of incomprehensible stuff! 'Found the child, Delight, with a perfect specimen of the *Cyrtopodium punctatum*, a native epiphytal orchid, in her tiny hand this morning. She must have picked it off the bark of tree under which she was sitting. Attracted by the colors, no doubt. Cried when I took it away."

"*The child, Delight!* There can't be any mistake about *that!*" cried Sydney. "But who can the person be that 's writing, and what relation to her—if any? Does n't sound like any near relation, I must say! But you 're not the only person that has discovered something. Listen to this!—'The inutility of all this grows upon me. I have no longer any great desire to live. When it 's all over with me, what 's to be done about *her*? But she shall not go back—a thousand times *no!*'

"There 's a whole book full in that little item, if we only had the key to it," commented Sydney, wisely. "Somebody 's tired of 'playing the game' and the little kid is going to be the sufferer. I 'm quite convinced now that there 's been great doings, somehow!"

In growing excitement they continued to scan the scraps of paper, sure that every other word or line would bring further enlightenment. But they were doomed to disappointment. Except for one additional personal item, there was not another clue to anything in all the maze of incomprehensible Latin, botanic and geologic allusions. This item arrested the eye of Bernice just as she was about to throw down the remainder of her papers in despair.

"I have paid Jerry all I have left for what he is to do. He did not wish it so, but the future is the future and must be provided for. It is the wisest solution. The child must not suffer, but she must never know—what I have known."

"That 's the most enlightening thing yet," she declared, when she had read it to Sydney. "Do you know, I have a brand-new idea about this whole thing. What she told us, combined with this, has made me certain. That Jerry Sawgrass has been paid by somebody, to take care of her, *because* she was n't wanted where she belonged. There have

such things happened—you know there have. But why, I can't quite understand. Oh, suppose she 's in danger—that poor little thing! And you were trying to tell me only to-day that she did n't need our help!"

"Oh, *wait* a minute!" exclaimed Sydney, his head in his hands. "You talk so fast and hard I can't even *think!* You do jump at conclusions in the most illogical way, too. Jerry Sawgrass has n't the faintest intention of 'harming her.' Nor has he ever been asked, probably. I have another explanation and, I *hope*, a more sensible one.

"There 's one thing maybe you don't know, but I 've heard of it a good many times, especially since I 've lived in Florida. The Everglades are a great hiding-place and shelter for escaped criminals and those who are dodging the law for some reason best known to themselves, deserting soldiers and a heap more of a like variety. I wonder if the one who made those notes was a fugitive from justice or something of the kind, living in the Glades and chumming around with Jerry? What in the world he 'd have a child with him for, I can't imagine, though I can easily see, if he *did*, how he 'd want that child protected, perhaps from the consequences of his wrong-doing, and even kept in ignorance of the whole affair, as it grew up."

"Yes, that certainly seems more sensible, Syd," admitted Bernice, meekly. "And yet I hate to think of Delight being connected in some way with a—*a criminal!*"

"But the weak point in my argument," mused Sydney, "is where all this *scientific* business comes in. I somehow can't picture any one with—with really wicked tendencies being so absorbed in the *fauna* and *flora* and all that sort of thing of the Glades and making elaborate notes about them. No, there 's a screw loose in that argument somewhere!"

"Well, anyhow, I think it 's the best explanation we 've struck yet," declared Bernice. But suddenly she sat up very straight and caught her breath. "Sydney Conant, if we really think that, what *are* we going to say to Delight to-morrow. I just *could n't* tell her any such supposition as that!"

"Don't say anything about it, of course. It would be cruel to put such an idea into her head. Have you thought what connection that man—that Mr. Tredwell may have with all this?" Sydney demanded, suddenly going off on a new tack. Bernice looked blank.

"Really, I 'd forgotten all about him," she acknowledged. "Such a lot has happened since. What do you think about it?"

"I think there 's some very close connection," he admitted. "Jerry recognized him and was wild to get out of his way. Jerry knows him and fears him for some reason. Therefore, I 'm not drawing too long a bow, as they say, when I take the liberty of thinking Mr. Tredwell has some bearing on things. I 'm going to watch him and, what's more, I 'm going to cultivate his acquaintance. Something may come of it!"

THE next afternoon they drove over to Number Six to keep the tryst with Delight, the precious packet ready to be handed back into her keeping. When they reached the pool, they reconnoitered carefully to make sure they were not observed by the occupants of the farm-house on the other side. But no one was in sight anywhere, so they sat down in the shadow of the big scrub-palmetto clump designated by Delight—and waited. The time drifted by as imperceptibly as the few light, downy clouds above the pool that scarcely seemed to move in the immeasurable depths of blue sky. Cardinals and mocking-birds sang and flirted their tails at them; a moccasin-snake, asleep near the edge of the pool, uncoiled himself presently and slipped into the water. And still Delight did not come.

Suddenly, Sydney could stand it no longer. "You stay here!" he commanded, rising and preparing for departure. "I 'm going to slip around the pool, keeping under cover, and just get over near the house and see what 's the matter. There 's something unusual about it. She has n't usually kept away like this. Maybe she 's sick or some one else is—or an accident or something. I 'll be back presently."

He slipped away behind the bushes and was soon out of sight, while Bernice remained, patiently watching. She could not see from where she sat what he did when he reached the other side of the pool—indeed, he had no intention that she should, for if he were visible to her, he would also be visible to the dwellers in the house. Sooner than she expected, he came scurrying back, singularly enough, without much precaution for keeping out of sight, and breathlessly he said:

"If you want to see something strange—come with me—and be *quick* about it!"





GRAND LAKE AT THE WESTERN ENTRANCE TO ROCKY MOUNTAIN NATIONAL PARK, COLORADO

## MOUNTAIN SCULPTURE

*Summer Days in Nature's Mountain Studios*

By FRANCIS B. ATKINSON

YOU can believe me or not, but I once saw the face of a beautiful woman age fifty years in five minutes. Several hundred other people saw the same thing. Then, with equal wonder and delight, we saw that face restored to its original beauty and with a sweet smile added, as if she had enjoyed it all as much as the rest of us!

The magician who brought about these remarkable changes was, as you of course suspect, a sculptor. He was illustrating for his audience, in the assembly hall of one of our great universities, some secrets of the sculptor's art. It was all extremely interesting, and the idea came to me one day that the readers of *ST. NICHOLAS* might be interested in some reflections I have been led into, in the course of the summer, on the

many and curious resemblances between the methods of human sculptors and the art methods of Nature in her mountain studios.

### I. THE MAN WITH THE IRON BONES

PROPERLY to understand the odd similarities between the work of the human artist and the work of Nature's craftsmen in the mountains, I suggest that we begin by visiting, in imagination, a sculptor's studio.

So here we are, and, by good fortune, just as he is taking the first steps in the carving of the figure of a man. But look what he's doing! He is n't working on a big man of marble at all—he's making a little man of clay. When we ask about this, he explains that as a rule the sculptor first develops his ideas in small clay models; shaping them as

you used to shape little clay figures of rabbits and people and things at school.

Now watch how the sculptor changes his little man of clay into a big man of marble. The first thing he does is to reproduce this first clay model in another clay model. This second clay model, however, is of the full size of the marble statue that is to be.

ENTER: THE MAN WITH THE IRON BONES

BUT, you see, so large a figure in clay could n't stand up, any more than you or I could, without bones of some sort. So the sculptor has a framework—a kind of skeleton, much simpler, however, than our bony skeletons—made of iron rods and wire, on which the clay of the larger model is molded. For the fun of the thing and just to help the story along, let's call "him,"—this combination of rods and wire,—“The Man with the Iron Bones.” These metal bones of his not only help him to stand up under his successive loads of clay,—for this queer creature “in his time plays many parts,”—but the sculptor can, by bending the rods and wires, cause him to assume any desired position. The frame is covered with lumps of clay, which the sculptor carefully molds with his fingers and with his modeling-tools so as to reproduce the outlines of the little model. First the framework with its clay is set on a revolving table so that the sculptor can always keep the part he is working on in the sunlight and see what he is doing.

When the larger model is completed, a plaster cast is made from it and this plaster figure is, in turn, reproduced in marble. It is necessary to duplicate the big clay figure in some harder material—such as plaster of Paris—because the final model is repeated in the marble by means of a device with long steel “fingers,” known as the pointing-machine, which could not be used in such a soft substance as clay. With this machine, the depth to which the marble block is to be cut at various points is indicated by holes bored into it. Then one of the sculptor's assistants, called the first chiselman, blocks out the figure in the rough, taking these holes and the model as his guide. Next, another and more skilful chiselman works the figure down more nearly to the finished form. Last of all, the sculptor himself puts on the finishing touches, and his dream, as first expressed in the little figure of gray-blue clay, stands out in all the glory of his marble manhood.

## II. IN NATURE'S MOUNTAIN STUDIOS

NOW notice the curious resemblances between the story of the sculptor's work and the story of the making of the mountains. First of all, remember how largely clay enters into the making of rocks. Many kinds of rock, including the slate rock from which your school slates are made, were originally only clay, while limestone and sandstone were originally only soft beds of material which have become hardened in the great stone presses of the earth. Even granite, the most durable material in the anatomy of mountains—the very backbone of mountains—was, much of it, originally clay rock, which has been melted and then cooled and crystallized.

This granite is constantly being ground back into clay by the beating of the waves along the cliffs, to be again made over into hard rock in its passage through the mills of the sea, and again shaped into mountains by the wrinkling up of the earth's crust. In the changing of softer kinds of rock into granite, the compression, the squeezing, which accompanies the mountain-wrinkling process, plays an important part.

Now take another process. For instance, you noticed that after the figure had passed through its clayhood, so to speak, and was ready to enter its marblehood, the form was at first only roughly blocked out in the marble, and successive artists brought it to its final form. Similarly, in the making of the mountains, one set of natural forces—call them “artists”—block out the scenery, and successive artists are constantly changing it and adding new beauties to it. Nature evidently prepares her mountains for this constant re-shaping. In the process of their formation, the granite portion of their anatomy—corresponding, let us say, to the skeleton of “The Man with the Iron Bones”—always underlies the vast layers of upheaved limestone, sandstone, shale, and other softer rocks that we find along the mountain flanks. The reason of this is that although the granite itself was originally sandstone, shale, or “pudding stone” (conglomerate), it was changed into granite by the heat generated by the squeezing process, which goes on when the mountains wrinkle up, and by the pressure of the overlying rock; so, while these underlying layers were changed into either granite or marble (limestone when changed by heat, under pressure, becomes not granite, but marble), the layers



we see on the mountain flanks remained the same kind of rock they were before.

But now notice what happens, regarded from an art standpoint. Because of this combination of rocks of many different textures and degrees of softness, the outlines of the mountains are constantly changing under the action of the elements; just as the marble, as originally blocked out, changes under the tools of the first chiselman, the second chiselman, and the sculptor himself. The softest rocks are worn away most rapidly, and present forms in contrast with harder rocks of other or similar kinds,—all sandstone, for example, is not equally hard,—thus helping to produce those infinite varieties of form which constitute one of the charms of mountain scenery. The softest rocks of all break up under the splitting action of the frost and the prying of tree-roots, and tumble down in the angular masses that we find at the mountain bases, along the mountain flanks, and in the mountain streams. In other words, the stones of which the mountains are built seem to be made and arranged for being reshaped by the forces of nature, quite as much as the clay of the sculptor is prepared for modeling.

#### TO GUIDE THE SCULPTOR'S HAND

HERE is another parallel equally striking; the fact that the shape the mountains are to take, under the action of the frost, the water,

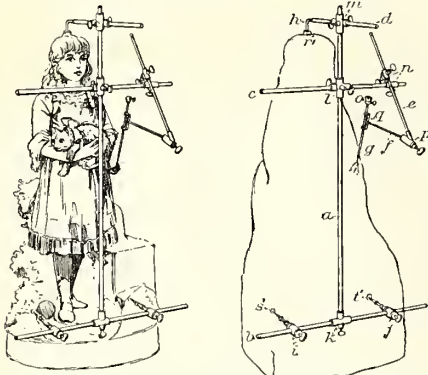

A POINTING-MACHINE WHICH SHOWS THE SCULPTOR WHERE THE FIGURE IS HIDDEN

and the winds, is controlled, much as the work of the chiselman is controlled by the previous use of the pointing-machine. But in order that we may see more clearly this curious analogy, we must first find out a little more about the business of that pointing-machine. You will find a picture of one

of these machines on this very page. From this picture you will see that it is an ingenious device with armlike rods and long steel fingers. These fingers are called pointers, and they are well named; for they really point out to the first chiselman where the figure is hidden, as it were. No doubt you remember, in reading in school about the lives of artists, that Michelangelo said he saw the figures he had in mind as prisoners in the marble block, and he simply released them with his chisel.

The pointers are placed so that while one rests on the plaster model, another pointer, on the opposite end of the rod, rests on the marble block. Then a hole is bored in the marble, so that the pointer will go into it to a depth which will bring the end of it exactly parallel to the end of the corresponding pointer resting on the model.

All the most prominent parts of the model are gone over in this way, so that the block is covered with holes, each reaching to where the pointers would stop if there really *was* a man hidden in the block and every time the sharp-pointed steel fingers touched him he said "Ouch!" Then the first chiselman cuts away the stone between these holes, and out comes the figure in the rough.

In Nature's mountain studios the guiding lines that help to control the course and action of the running streams and the rains, and to furnish openings in which ice forms and splits the rocks, are certain pretty regularly arranged cracks which the geologist people call "joints." We call a joint a place where things are joined together, but in geology it's a place where they are pulled apart. These joints occur in all kinds of rock that are not so soft that they easily crumble. As the rock crust of the earth follows the cooling and shrinking interior, it is pressed together in some places, stretched in others, and twisted in others. All these movements help to make joints.

Into these joints the rain filters, and, with the acids which it has dissolved out of dead vegetation and out of the soil, etches the rocks away. Up these joints rise the etching waters of the springs. Into them the frost drives its ice chisels and the roots of trees work their way. Thus as the holes bored in the marble help determine the final shape of the finished figure, the joints help determine the plan and shape of the mountain crest, the lofty walls of the cliffs, the great buttresses of the cathedral rocks and their dark recesses, haunted by the shadows.

## THE READING OF LANDSCAPES

WHILE no two forms of rock are exactly the same, just as you can not find two leaves ex-

“The Man with the Iron Bones,” in the granite backbone of the mountains.

2. Of the changing of the clay model into marble, in the hardening of the rocks out of



LIKE A SILVER THREAD LEADING TO SNOW-CAPPED PEAKS, IS THE WINDY POINT TURN IN ROCKY MOUNTAIN NATIONAL PARK

actly alike even on the same tree, still each kind of rock gives us its characteristic scenery, and you can learn to read a landscape as you learned to read a book. Sandstone, for example, is shaped into gently rounded forms; trap-rock crumbles into picturesque ruins of angular blocks; granite sharpens into mountain peaks and stern-browed cliffs, and its broken blocks become those round-shouldered boulders that cover the fields and mountain-sides of New England. Limestone is eaten full of pits by the water uniting with the lime, as you have often noticed in pictures of rock masses by the sea, in the “movies.”

To sum up, then, we find in nature:

1. The counterpart of the anatomy of

their original soft condition in the sea's rock mills.

3. The evident preparation of this rock for shaping by the elements, as the clay is specially prepared for working under the hand of the sculptor.

4. The guiding lines of the joints, corresponding to the holes bored by the pointing-machine.

## WORKING IN THE SUNLIGHT

NEXT take the matter of the use of sunlight. It is easy to understand, of course, that the sculptor would work in the sunlight so that he could see just what he was doing and get the exact effects desired; but why should the sculptors of the mountains prefer to work



in the sunlight? That they do is plain enough; for you will always find the sunny faces of mountain walls the most varied in form and decoration.

One reason for this is that stone, like metal, expands when it is heated, contracting again as it cools. In the mountains the difference between the temperature of day and night is very great. In the great mountains of the West, for example, 6000 feet above the level of the sea, the day temperature may be as high as 140 degrees and rocks get so hot they will make a blister if you touch them. At sunset the temperature immediately takes a tremendous drop. By ten at night it will be freezing cold and ice where there is any water to freeze, will set to work in the crevices of these same rocks. But rock, being a poor conductor, neither the heat of the day nor the cold of the night penetrate far. As a result of this difference in temperature the outside of the rock is constantly pulling away from the inner and falling off. Many of the pieces that are loosened by the cold of the night cling until they are again expanded by the heat of the morning sun, and then they break away and go tumbling down the mountain-side.

If you are spending your summer vacation in regions of very high mountains, such as the Rockies, and take a climb about daybreak to see the glory of a mountain sunrise, you will hear the chips of stone come rattling down faster and faster as the sun mounts higher and higher and loosens the chips made by the frost sculptors of the night. Sometimes they come down in perfect avalanches, there are so many of them—as if some giant sculptor were attacking the stone in the fury of his artistic zeal, as Michelangelo used to do. In falling, they echo from crag to crag like the rattle of artillery.

Another source of this self-carving process of rocks is that in the anatomy of many of them there is iron. Under the heat of the sun's rays, these iron particles stretch more than the other particles, and then, after the sun goes down, contract more than their neighbors. Thus the mountain studios have their "iron bones" in this one also, and these bones, besides performing the function of an anatomy for the mountain, help in the constant reshaping of it, contracting and stretching like a living thing.

Wouldn't the sculptor be astonished if *his* man with the iron bones should reach out for the tools some day and begin chipping at the marble?

Large blocks, together with many smaller fragments, are also carved from the mountains by the action of ice. The sun melts some of the snow in the mountain snow-fields and the water runs into the cracks and freezes at night. Then, under the heat of the next morning's sun, the ice lets go of the rock it has broken away, and down it rattles and thunders over the face of the mountain and into the echoing cañons below. Tons and tons of rock are chiseled out of every mountain in this way each winter, but above the snow-line of the higher mountains the work goes on all the year.

#### MOUNTAIN SCULPTORS WORK TOGETHER

RECALLING again how the sculptor and his two assistants work together, notice that we have a similar thing in the coöperation between the rain and the frost, the day and the night, the sun and the wind, the running streams, the chemists that supply the etching acids from the decaying vegetation, and so on. The raindrops and the water from melting snow, besides working with the chemists, do great things when united in the form of rivers. For one thing they cut the grand water-gates through which the rivers pass back to the sea; carve gullies in the mountain flanks, for another thing; dig out the beautiful river valleys, for another.

Similarly we find summer and winter working together in the shaping of the rocky walls of mountain valleys. At the head of many of these valleys are great open spaces, sometimes called "amphitheaters." All these amphitheaters used to be, and many still are, filled with those great masses of flowing ice called glaciers. In the winter, this ice freezes to the valley walls, and then in the spring, when the glacier, owing to the pressure of the accumulated winter snows in the mountain regions above, begins to flow more rapidly, the ice pulls loose from the walls and carries away pieces of the rock, thus cutting the amphitheater farther and farther back into the cliffs.

Another interesting example of coöperation is where two rivers act together in cutting a gorge. If you are in a region of mountains, you know what a lot of streams go tumbling down their flanks. Streams on opposite sides of a mountain cut their way, in course of time, right into the heart of it. It often happens that two streams, cutting from opposite sides, meet, and so form a gorge. Then the river that runs through the gorge is a combination of the two rivers

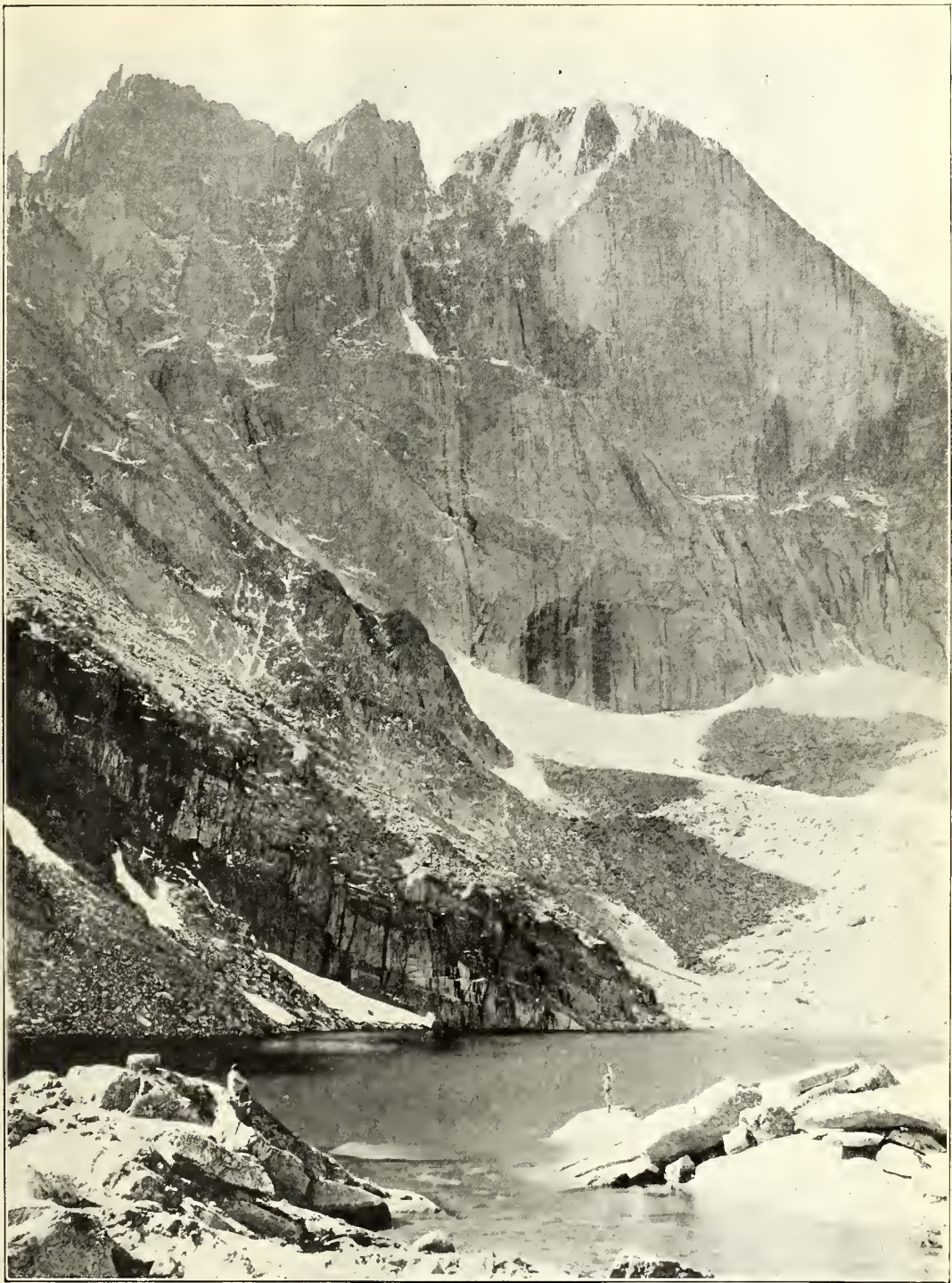

ONE OF NATURE'S MOUNTAIN STUDIOS—LONG'S PEAK, COLORADO, WITH CHASM LAKE  
IN THE FOREGROUND

*"At sunrise the chips of stone come rattling down, as if some giant sculptor were attacking the mountain in the  
fury of his artistic zeal!"*



that have thus gone into partnership, the final direction of the stream being determined by the slope of the land. Some of the gorges high in the mountain walls were made by streams that have disappeared.

The well-known artist Frost—not A. B. but Jack—and the rivers also work together. Rivers as sculptors are like human beings in that they are unable to work without tools. So when the frost pries fragments from the rocks on the banks and tumbles them down into the mountain streams, the flowing water uses them to deepen and widen its bed. It was by the use of just such tools that the Colorado River was able to dig that vast abyss, the Grand Cañon.

These workers in the mountain studios may be said to be divided up into artist colonies, each artist being a member of several groups. In addition to the groups already named, we may mention the cooperative arrangement between the rain, the wind, and the wind-borne seeds. Into the cracks of the mountain rocks the rains wash down soil—the decay of the rocks above. Then the little winged seed of a tree—usually of the pine, the great mountain climber of the tree family—carried by the wind, lodges in this soil and takes root. As it grows, the roots work down into the crack and, as they enlarge, split pieces of the rock away.

### III. STORY OF THE STONE IMAGES THAT STEPPED OUT OF THE WALL

DID you ever notice in the pictures of the statues of Egyptian kings, in your illustrated Sunday-school Bible, a block of stone at the back of their necks; that on the statue of Rameses II, the Pharaoh of the Exodus, for example? For a long time the scholars who make a study of such things wondered what this could mean. Then they found, by comparing the work of sculptors of different times in Assyria and Egypt, that the idea of making statues of stone did n't come to them all at once. It was the custom, in these countries, to record on the walls of the temples the life and exploits of their gods and their kings. This they did in scenes and figures cut into the stone, showing the gods and kings performing the various exploits attributed to them. The artists, whose business it was to cut these records in picture language, did the easiest thing first; they simply cut the outlines of the figures in the stone, much as an artist would draw them in outline on paper. Gradually, as the artists grew more skilful, they made the

figures stand out, by cutting away the stone between these outlines and rounding the outlines themselves. Thus they stood out in relief, like the figures on a cameo or a Wedgwood tea-pot.

Then, in the course of many centuries, the idea developed in the brains of the sculptors that if their royal masters would consent to have their stone images come entirely out of the wall, so that the artists could chisel all around them, they would bear a much more striking likeness to the original. However the idea came about, it was at last adopted. But the stone representation of



RAMESES THE KING, AT THEBES,  
FROM "DESCRIPTION DE LA  
EGYPT"

a god or king with no hint of a wall about it,—when neither the king nor his ancestors had ever seen or heard of such a thing,—that was too bold an innovation. What would the gods say? Worse than that, what would the gods *do* if they did n't happen to like it? Long-established customs tend to become fixed in all countries, and particularly is this true in the

"changeless East." It was even prescribed to the Egyptian artists how they must carve the stone representation of the king's beard.

So, while the thing undoubtedly came about step by step and century by century, we can sum up the long process by conceiving of some first sculptor who was bold enough to suggest that he could make an even more glorious likeness of his mighty lord if he could only show him free from a wall; that thereupon they held grave council—the Pharaoh and his ministers and the priests of the temple and decided on a compromise.

"You may try your hand at such a statue,"—we can imagine this was the decision,—"but there must be some reminder of the walls of the temples and the walls of the tombs from which the images of our fathers and the gods look down on us. These walls also are sacred things."

So the sculptors proceeded to make statues in the round, as it is called; but they

left that section of stone at the back of the figure to stand for the wall. The whole history of the thing is for all the world as if these solemn effigies of divinities and dead kings had slowly pulled themselves out of the surface of the stone and walked away, with a piece of the sacred wall still sticking to their sacred backs!

Now notice the parallels between this curious chapter in the history of art and the work and ways of the sculptors that adorn the mountain galleries. First of all, you have the beginnings of forms blocked out by the joints, corresponding to the incised outlines of the earlier sculptors of Egypt and Assyria. In time, by the action of the elements, these outlines become rounded; and finally many stand out as complete figures.

Quite often, these figures are produced by streams of water flowing through the joints and gradually cutting away the block from its parent rock. On the borders of the sea, where there are cliffs and mountains, there are many of these isolated figures standing out in the water. They are sometimes called "sentinel" rocks—strange, grim creatures that seem to be keeping watch and ward along the coast. They were originally a part of the cliffs and were cut away by the incessant beating of the waves of the sea.

Just north of the Dales in Wisconsin is a lonely pillar of stone called Standing Rock that has a stranger history still. It was carved out by—what do you think—the wind! It stands close to a cliff. This cliff is of sandstone, but the top layer is of harder sandstone than the rest of it. The figure, which is 45 feet high and 6 to 8 feet in diameter, wears a broad brimmed "hat" of this harder stone, which is at just the same height as the sandstone of the same material projecting toward it, like a cornice, from the cliff. The two stones are as much alike in texture as two pieces of bread cut from the same loaf. The geologist people reason about it in this way. They say:

"Either this figure and this cliff were built separately and carefully crowned with the same kind of stone at just the same level,—that's the way men would do it,—or the figure and the cliff were formerly all one mass and the figure has been carved away from the cliff. But no river flows between it, and the cliff and the records on the rocks report that no river ever did."

"What then?"

"This is what happened: the stone of which the figure is made was once part of

the cliff, but a joint marked out the place where Nature's artists were to set to work. Then the frost, with its swelling wedges of ice, and the sculptors of the Night and Day,—expansion by the sun's heat by day and contraction in the cool of the night,—the wedges of roots reaching eagerly after the soil lodged in the joints, cut the rock away along this dividing-line, until finally there was an opening that the winds could get through. Then, with a swirling action, like that of water shaping a sentinel of the sea, the wind loosened and carried away millions of grains of sand out of the sandstone block. Finally, these winds not only carved out the big gap that now separates the figure from its parent cliff, but cut through the harder stone that capped them both, and there the figure stood all by itself as we see it to-day."

The most famous of Nature's works of sculpture, made in this way, is that on the borders of the Dead Sea, which Arab tradition says is Lot's wife, as she appeared after she looked back.

Notice on any clay bank in which there are pebbles, how, after a sudden heavy shower, there are left similar figures in all stages of formation—in some places, only outlined by the grooves cut by the little streams of rain, while at other places the forms begin to be rounded and to stand out from the bank, or completely cut away.

Not only that, but you can find many other features of the art of the mountains in the high clay banks of any sunken road or in the rain-washed gullies of the hills. There are fairy gorges, where the water has cut its way down the embankments; shelving terraces, like those of the walls of the Grand Cañon, where a temporary stream, produced by the shower, has sunk to lower and lower levels; mountain peaks, where a tiny rivulet has been divided by a cobblestone or a projecting root and so has cut around a mass of clay. What here are pebble-heaps are, in the mountains, great ruins of angular stone or masses of round-shouldered boulders, over which the swift mountain stream rushes.

So these little roadside landscapes tell, in simple language, many of the art secrets of the sculpture of the mountains. They seem to rehearse, in a kind of moving picture or animated tableau, during the short period of a summer shower, the grand drama that the elements play and have been playing on the vaster stage among the great upheaved walls of stone which we call mountains, in the long ages since the world began.



# THE TURNER TWINS

By RALPH HENRY BARBOUR

*Author of "The Crimson Sweater," "The Mystery of the Sea-Lark," etc.*

## SYNOPSIS OF PREVIOUS INSTALMENTS

NED and Laurie Turner, twins, and so much alike that even their best friends find it difficult to tell them apart, are students at Hillman's School. Ned, although inexperienced, has joined the football candidates, and, by dint of hard work, secured a place on the second team and a reputation as a goal kicker. In the game with High School, the last before the big contest, he goes in and kicks a nice goal after a touchdown. As the day of the big game approaches, he gets stage-fright, and the prediction that he will be called on to attempt a field-goal against the school's old rival, Farview, adds to his nervousness. The night before the contest is a bad one for Ned, and he awakes on Saturday morning feeling, to use his own words, like a sock that's just come through the wringer!

## CHAPTER XX

### NED IS MISSING

NED ate almost no breakfast, and Laurie noted the fact, but, after a glance at his brother's face, said nothing. After all, he reflected, there were probably others of the squad who were displaying no more appetite that morning. Afterward, on the way to School Hall for their only recitation of the day, he asked offhandedly, "How are you feeling, Neddie?"

Ned did n't answer at once. When he did, he only replied laconically, "Rotten!"

"How do you mean, rotten?" Laurie disguised anxiety under flippancy. "Tummy out of whack? Or is it a case of ingrowing signals?"

"I don't know what the trouble is," answered Ned, seriously. "I feel perfectly punk. And I—I'm scared, Laurie. I'd give a million dollars if I did n't have to go to the field this afternoon. I wish to goodness I could duck somehow. Say, feel my forehead. Is n't it hot?"

Laurie felt, and shook his head. "Cool as a cucumber, you old fakir. Buck up, Neddie! You'll feel better after a while. Did you sleep all right?"

"I guess so," replied the other, disspiritedly. "I dreamed a lot. Dreamed I was kicking goals over a bar as high as a mountain. And the ball was as big as a hoghead. Therewere about a million folks watching me, and Mr. Cornish was beating a bass-drum."

Laurie laughed. "Some dream, Neddie! Tell you what. After we get out of here, we'll take a nice, long hike. Mulford wants the players to stay outdoors, does n't he? Did n't you tell me he said you were to walk or something?"

Ned nodded. "I'm too tired to walk, though, Laurie. Guess I'll get a book and go over to the park. Or go down and jump in the river!"

"Fine idea!" scoffed Laurie. "What have you got against the river? It never did anything to you, did it?"

Ned, however, refused to smile. "You don't need to come along," he said. "I—I guess I'd rather be alone, Laurie."

"You will be, if you're going to jump in the river, partner! The water's a heap too cold to appeal to me. Well, cheer up. See you when we come out."

There was a holiday feeling in the air this morning that did n't promise well for recitations, and Mr. Brock's chemistry class was a sore trial to that gentleman. Yet, although he frowned often and sighed many despairing sighs, he made allowance for the prevailing mood of restlessness and exhibited unusual patience. And finally it was over and the class trooped out.

"You stay here," said Laurie, "and I'll run over and get a couple of books from the room. What do you want?"

"I don't care—anything," answered Ned, listlessly.

When Laurie went off, Ned seated himself on a step and gazed forlornly around him. Groups of boys stood about on the walks in animated conversation. Near at hand, a half-dozen juniors were discussing the game avidly, drawing comforting conclusions from a comparison of the season's performances of Hillman's and Farview. Suddenly, the prospect of sitting on a park bench with Laurie became utterly distasteful to Ned, and, with a hurried glance in the direction of East Hall, he arose and made his way along the drive and into Summit Street. There he

turned to the left and walked quickly to the corner. At Washington Street another look behind showed that he had made his escape, and he heaved a sigh of relief and went on past the library and into Cumber Street, heading unconsciously toward the open country eastward of town.

When Laurie returned to School Hall with a book for Ned and a magazine for himself, he sat down for a few minutes, supposing that Ned would be back. When he did n't come, Laurie went over to School Park, thinking that he had perhaps grown tired of waiting in the yard. But no Ned was to be seen, and puzzled, but untroubled, Laurie dawdled into Pine Street. The white-and-red sign above the Widow Deane's little store shone bravely in the sunlight. For an hour Laurie enjoyed the society of Polly and Antoinette in the sunny garden, where, against the board fence, a clump of hardy chrysanthemums made a cheery showing of yellow and lavender. Antoinette had retired to winter quarters, which means that a gunny-sack and a length of old red carpet had been draped over her box. But just now the drapery was lifted, and Antoinette was doing great things to a very large cabbage-leaf.

Laurie and Polly talked, of course, about the game. He and George were again to act as escorts to the two girls, a fact that had eaten a large hole in Laurie's remaining allowance. About ten o'clock he took himself away, reminding Polly to be ready at half past one, since it took a good ten minutes to walk to the field.

Climbing the fence into Bob's yard, he discovered that young man with a new crowbar about to begin an attack on the remaining posts of the arbor. So he removed his sweater, moistened his hands in the time-honored and only efficacious manner, and joined the assault. After the posts were added to the pile beside the fence, the two boys went indoors and refreshed the inner man with piping-hot ginger cookies. Thus it was that it was nearly noon when Laurie got back to Number 16, to find, to his uneasiness, that Ned was not there. Nor, as far as any evidences showed, had he been there since before breakfast.

Laurie threw himself on the window-seat and tried to apply himself to the magazine that he had carried all the morning. But he began to be really worried about Ned. He did n't understand where he could be. Even if he had gone off by himself, mooning

along the roads, which was what Laurie suspected he had done, he should have been home before this, for, as Laurie knew, the players were to go to lunch at twelve. Presently he dropped the magazine and strode across the corridor to Number 15. Kewpie was not in, but Hop was there—a more than ordinarily serious-faced Hop, who replied to Laurie's inquiry in an absent-minded manner which suggested that some one had placed him in a trance and gone away without awakening him. Hop had n't seen Nid all morning. Kewpie had just gone over to West Hall. He hoped there would n't be any wind this afternoon. Farview had a punter that could do fifty yards easily, and a wind would lengthen his kicks. Did Nod think those clouds meant wind?

Laurie withdrew without venturing an opinion in the matter. Football, he reflected, was a far more dangerous pastime than folks generally realized, when it could affect a fellow's brains like that! Downstairs, he searched the little group about the dining-hall door and finally made inquiry of Dave Murray. Dave was worried and excited and a bit short-tempered.

"Nid Turner? No, I have n't seen him. He 'll be here pretty quick, though. We eat at twelve." He left Laurie, to push his way toward the entrance to accost Mr. Mulford, who was coming in; and Laurie went out and sat down on the step and watched. Kewpie came striding across from West Hall, smiling and evidently very fit. But when Laurie questioned him the smile faded.

"Nid? No, I have n't set eyes on him. Is n't he here? Are you sure? Say, you don't suppose the silly guy has bolted? He was in mean shape last night, Nod. But he would n't do that! He 's no quitter. He 'll be here in a minute or two."

"Suppose—suppose he is n't?" asked Laurie, anxiously. "Would it matter much?"

"Matter?" Kewpie shrugged, one eye on the dining-hall door, through which his team-mates were beginning to pass. "It would n't matter to the game, I guess. I was only trying to cheer him up last night. You understand. It is n't likely Pinky will use him. But it would be a bad thing for him, Nod. It would be an awful black eye, in fact, if he cut the game. Guess Pinky would just about can him for all time! I say, I 've got to hustle in there. Why don't you have a look around for him? Maybe he 's in the library, or over in West, or—somewhere. See you later, Nod!"



Kewpie disappeared into the dining-hall, and a moment later the door was closed. Laurie acted on Kewpie's suggestion and made a thorough search of School Hall and the other dormitory, and even poked his head into the gymnasium, where only an empty floor met his gaze. After that, there seemed nothing to do but wait. Ned had already missed his lunch, for the fellows were coming out into the corridor when Laurie returned to East Hall. Murray nailed him as he tried to pass unnoticed to the stairs.

"Say, Nod, where's that brother of yours?" he demanded indignantly. "Did n't he know that lunch was at twelve? Where is he, anyway?"

"I don't know, Dave," Laurie answered miserably. "He went for a walk this morning, and I have n't seen him since. I guess he went too far and could n't get back in time. I've been looking all over for him."

"That's fine!" said the manager, bitterly. "Mulford asked for him, and I said I'd look him up. You'd better find him mighty quick, Nod. Tell him to get something to eat somewhere and be at the gym not later than one. There's a floor drill then. I'll make it all right with Mulford, somehow. But there'll be the dickens and all to pay if he does n't show up!"

Hoping against hope, Laurie hurried up to the room. But there was no Ned. One o'clock came and passed. Time and again Laurie went to the gate and looked up and down the street, but without result. Ned had disappeared utterly, it seemed, and the unwelcome conclusion grew in Laurie's mind that Ned had shown the white feather and had deliberately absented himself. Laurie did n't like to think that, and there were moments when he could n't. But here it was nearly half past one and Ned had n't come, and facts are facts! It looked, he thought sadly, like a bad day for the honor of the Turners!

At half past one he found George Watson in his room and handed over one of his tickets. "I can't go to the field with you," he said, "but I'll find you over there. Try to keep a seat for me, will you?"

"What's the big idea?" asked George, blankly. "Why can't you go with us? That's a fine game to play!"

"I'll tell you later. I—I've got something to do. Be a good fellow, George, won't you? And tell Polly how it is, will you?"

"How the dickens can I tell Polly how it is when I don't know how it is myself?"

asked George, indignantly. "Oh, all right! But you want to get there pretty quick, Nod. It's hard to hold seats when there are n't enough of them in the first place. There's a big mob going out there already!"

Disconsolately, Laurie hurried out and stationed himself at the dormitory entrance. Presently the players emerged from the gymnasium in their togs and passed through the little gate to Washington Street. Laurie watched them file past, hoping hard that Ned would be among them. But although all the rest were there, twenty-one in all, there was no Ned.

From Washington Street and Summit Street came a steady tramping of feet, accompanied by a swishing sound as the pedestrians brushed through the fallen leaves. Occasionally an automobile went by with a warning honk of its horn at the corner. Looking over the withered hedge, Laurie could see the colors of Hillman's and Farview marching past, banners of dark blue bearing the white Old-English H, maroon-and-white flags adorned with the letters "F. A." Laughter and the merry, excited chatter of many voices came to him. The yard was empty, except for a boy hurrying down the steps of West Hall, and he, too, quickly disappeared through the gate.

Presently, Laurie looked at his watch. The time was eighteen minutes to two. He left East Hall and turned toward the gymnasium. Out of the shelter of the dormitory, a little breeze fanned his face, and he remembered Hop Kendrick's dread of a wind that would put more power into the toe of the Farview punter. It might be, he reflected, that Hop was due for disappointment; but the matter did n't seem very important to him. The locker-room in the gymnasium was empty. Over the benches lay the discarded underclothing of the players, and sometimes the outer clothing as well, suggesting that excitement on this occasion had prevailed over orderliness. Laurie made his way to Ned's locker. It was closed, and behind the unfastened door hung his togs.

## CHAPTER XXI

### FOR THE HONOR OF THE TURNERS

WALKING felt good to Ned that morning. The air, brisk in spite of the sunshine and the day's stillness, cleared his head of the queer cloudiness that had been there since awakening, and, turning into the country road that led eastward toward the higher

hills, he strode along briskly. He had, he reflected, played a rather low-down trick on Laurie; but that could be explained later, and Laurie would n't mind when he understood. When he had gone the better part of a mile into the country and the road had begun to steepen perceptibly, the sound of a motor behind warned him to one side. But

enough. Maybe you can get a lift going back, if you 're not in too much of a hurry. Still, there is n't much travel on this road. Most folks go around by Little Windsor. It 's longer, but the road 's a sight better. I go this way because I can do it quicker. There are some fierce bumps, though. Just let me know if you happen to drop out!"



"A SMALL, DUST-COVERED CAR OVERHAULED HIM AND WENT BY" (SEE NEXT PAGE)

instead of passing in a cloud of dust, the automobile slowed down as it reached the pedestrian, and the driver, a genial-looking man of middle age, hailed.

"Going my way?" he asked. "Get in if you like."

Ned hesitated, and then climbed in beside the solitary occupant of the car. The prospect of speeding through the sunlit morning world appealed to him, and he thanked the driver and snuggled into the other corner of the front seat.

"That 's all right, my boy," answered the man, genially. "Glad to have company. How far are you going?"

"Just—just up the road a ways," replied Ned, vaguely. "I was out for a walk, only this seemed better."

"Well, it 's quicker, though it does n't give you quite so much exercise," was the response. "You sing out when you 've had

The car was a heavy one with good springs, and as long as Ned remained in it the bad bumps did n't materialize. His companion evidently liked to talk, and Ned learned a good deal about him and his business, without, however, finding it very interesting. The man asked few questions, and so Ned merely supplied the information that he was from Hillman's School and that he liked to walk and that he had all the morning to get back in. The car kept up an even, effortless speed of twenty-seven or -eight miles an hour, and it was finding himself booming up the straight grade over Candle Mountain that brought Ned to a sudden realization that if he meant to get back to school by twelve o'clock without undue effort, he had best part company with his chatty acquaintance. So at the summit of the hill he said good-by, repeated his thanks, and got out.

"Guess you 're six miles from Orstead,"



said the man. "It won't take you long to get back there, though, if you find a lift. Don't hesitate to stop any one you see; they'll be glad to take you in. Good-by!"

The gray automobile went on and was speedily dropping from sight beyond the nearly leafless woods. Ned watched it disappear, and then set his face toward home. The ride had certainly done him good, he told himself. The prospect of being called on to kick a dozen goals would n't have dismayed him a mite at that moment. In fact, he suddenly realized that he was going to be horribly disappointed if the chance to attempt at least one goal from the field did not come to him, and he wondered why he had felt so craven last night.

After a mile or so, a small, dust-covered car overhauled him and went by without a challenge from him. It yet was still only ten o'clock, he had two hours, and he had no intention of begging a ride. Taken leisurely, the remaining miles would be covered without weariness and in plenty of time. When he had accomplished, as he reckoned, about half the distance to Orstead, his watch said seventeen minutes to eleven. The forenoon had grown appreciably warmer, and so had Ned. Beside the road was a little knoll carpeted with ashy-brown beech-leaves. Only a stone wall, bordered with blackberry briars, intervened.

Ned climbed across the wall and seated himself on the slope of the knoll. The land descended gently before him toward the river and the town, but neither was in sight. Presently, removing his cap, he stretched himself on his back and linked his fingers under his head. And presently, because the blue, sunlit, almost cloudless sky was too dazzling to gaze at long, he closed his eyes. And as he did so a strange, delicious languor descended upon him. He sighed luxuriously and stretched his legs into a more comfortable position. It was odd that he should feel sleepy at this time of day, he thought, and it would n't do to stay here too long. He wished, though, that he did n't have to get anywhere at any especial time. It would be great to just lie here like this and feel the sun on his face and—

At about that moment he stopped thinking at all and went sound asleep.

When he awoke he was in shadow, for the sun had traveled around past the elbow of a nearby old and knotted oak whose brown-pink leaves still clung to the twisted branches. Ned looked around him in puzzlement, and

it was a long moment before he could account for his surroundings. When he had, he sat up very quickly and gave a startled look at his watch. The thing was crazy! It said twenty-one minutes past two! Of course it could n't be that late, he told himself indignantly. But even as he said it he was oppressed by a conviction that it was. And a look at the sun removed any lingering doubt!

He sprang to his feet, seized his cap, and stumbled across the wall, and, again on the road, set out at a run toward home. But after a moment he slowed up. Was there any use in hurrying now? The game was already in progress—had been going on for twenty minutes. The first quarter was probably nearly over. What would they say to him, the fellows and Coach Mulford and—Laurie? Somehow, what Laurie would think appeared far more important than what any of the others might. He would have such a poor excuse, he reflected ruefully! Went for a walk, and fell asleep by the road! Gee, he could n't tell them that! He might tell Laurie; but the others—

He was jogging on as he thought things over. Even if he ran all the way, and he could n't do that, of course, he would n't get to school before three. And then he would have to change into his togs and reach the field. And by that time the second half would have started. Would n't it be far better to remain away altogether? He might easily reach his room unseen, and then, when Laurie returned, he could pretend illness. He might not fool Laurie; but the others, Coach Mulford and Dave Murray and the fellows, would have to believe him. If a fellow was ill, he could n't be expected to play football. He even got as far as wondering what particular and peculiar malady he could assume, when he put the idea aside.

"No use lying about it," he muttered. "Got to face the music, Ned! It was your own fault. Maybe Mulford will let me down easy. I would n't like to queer myself for next year. Gee, though, what'll the school think?" And Ned groaned aloud.

While he had slept, five vehicles had passed him, and as many persons had seen him lying there asleep in the sun and idly conjectured about him. But now, when he needed help to conquer the interminable three miles that stretched between him and the town, and although he constantly turned his head to gaze hopefully back along the

dusty road, not a conveyance appeared. Before long, since he had unwisely started at too great a speed, he was forced to sit down on a rock and rest. He was very nearly out of breath and the perspiration was trickling down beneath his cloth cap. A light breeze had sprung up since he had dropped asleep, and it felt very grateful as it caressed his damp hair and flushed face.

Perhaps those three miles were nearer four, because when, tired, dusty, and heart-sick, he descried the tower of the Congregational church above the leafless elms and maples of the village, the gilded hands pointed to twelve minutes past three. Even had he arrived in time, he reflected miserably, he would never have been able to serve his team-mates and his school, for he was scarcely able to drag one foot behind the other as he finally turned into the yard.

The place appeared deserted, grounds and buildings alike, as Ned unhesitatingly made his way across to the gymnasium. He had long since decided on his course of action. No matter whether he had failed his coach and his schoolmates, his duty was still plain. As late as it was, he would get into his togs and report at the field. But when, in the empty locker-room, he paused before where his football togs should have been, he found only empty hooks. The locker, save for towels, was empty!

At first he accepted the fact as conclusive evidence of his disgrace—thought that coach or manager or an infuriated student body had removed his clothes as a signal of degradation! Then the unlikelihood of the conclusion came, and he wondered whether they had really been there. But of course they had! He remembered perfectly hanging them up, as usual, yesterday afternoon. Perhaps some one had borrowed them, then. The locker had been unfastened, probably, for half the time he forgot to turn the key in it. Wondering, he made his way out of the building, undecided now what to do. But as he reached the corner a burst of cheers floated to him from the play-field. His head came up. It was still his duty to report, togs or no togs! Resolutely he set out on Summit Street, the sounds of battle growing nearer as he limped along.

By the entrances many automobiles and some carriages lined the road. Above the stand the backs of the spectators in the top row of seats looked strangely agitated, and blue flags waved and snapped. A fainter cheer came to him, the slogan of Farview,

from the farther side of the field. He heard the piping of signals, and a dull thud of leather against leather, then cries and a whistle shrilling; and then a great and triumphant burst of cheering from the Blue side.

He hurried his steps, leaped the low fence beside the road, and came to a group of spectators standing at the nearer end of the long, low grand stand. He could see the gridiron now, and the battling teams in mid-field. And the score-board at the farther end! And, seeing that, his heart sank. "Hillman's 7—Visitors 9" was the story! He tugged the sleeve of a man beside him, a youngish man in a chauffeur's livery.

"What period is it?" he asked.

"Fourth," was the answer. The man turned a good-natured look on the boy's anxious face. "Been going about four minutes. You just get here?"

Ned nodded. "How did they get their nine?" he asked.

"Farview? Worked a forward pass in the second quarter for about thirty yards, and smashed over for a touchdown. They failed at goal, though. That made 'em six, and they got three more in the last quarter. Hillman's fumbled about on their thirty, and that bandy-legged full-back of Farview's kicked a corking goal from field."

"Placemert or drop?"

"Drop. Almost forty yards, I guess. There they go again!" The chauffeur tip-toed to see over a neighbor's head. Ned, past his shoulder, had an uncertain glimpse of the Maroon-and-White breaking through the Blue's left side. When the down was signaled, he spoke again.

"How did Hillman's score?" he asked.

"Huh? Oh, she got started right off at the beginning of the game and just ate those red-legs up. Rushed the ball from the middle of the field, five and six yards at a whack, and landed it on the other fellow's door-sill. Farview sort of pulled together then and made a fight; but that big chap, Pope, the full-back, smashed through finally, right square between the posts. After that, he kicked the goal. Guess the red-legs had stage-fright then, but they got over it, and our fellows have n't had a chance to score since. Pope had to lay off last quarter. They played him to a standstill. Mason's mighty good, but he can't make the gains Pope did. First down again! Say, they are n't doing a thing but eating us up!"

Ned wormed himself to the front of the group and came to anchor at the side of a



tall policeman, close to the rope that stretched from the end of the stand well pass the zone line. By craning his neck, he could look down the length of the field. White-sweated, armed with big blue megaphones, Brewster and Whipple and two others, cheer leaders, were working mightily, although the resulting cheers sounded weak where Ned stood. The teams were coming down the field slowly, but surely, the Blue contesting every yard, but yielding after every play. The lines faced each other close to the thirty now. Across the gridiron, Farview's pæans were joyful and confident, and the maroon-and-white flags gyrated in air.

A line attack turned into an unexpected forward pass, and a tall Farview end came streaking down just inside the boundary. Hop was after him like a shot; but Deering, who had taken Pope's place, ran him out at the fifteen-yard-line. The Maroon-and-White went wild with joy. The teams trooped in on the heels of the diminutive referee, and the ball was down just inside Hillman's fifteen. Ned looked the Blue team over. Save for Corson and White, the line was made up of first-string men, but the back field was, with the single exception of Mason, all substitutes: Kendrick, Boessel, and Deering.

A plunge straight at the center gave Farview two more precious yards, Kewpie, apparently pretty well played out, yielding before the desperate attack. Three more yards were gained between Emerson and Stevenson on the left. Third down now, and five to go! Evidently, Farview was determined on a touchdown, for on the nine yards, with an excellent chance for a field-goal, she elected to rush again. But this time the Blue's center held, and the Farview left half, when a friend and foe was pulled from above him, held the pigskin scarcely a foot in advance of its former position. It was now Hillman's turn to cheer.

Fourth down, and still five yards to gain! Now Farview must either kick or try a forward, and realizing this, the Blue's secondary defense dropped back and out. A Farview substitute came speeding on, a new left tackle. Then, amid a sudden hush, the quarter sang his signals: "Kick formation! 73—61—29—" The big full-back stretched his arms out. "12—17—9!" Back sped the ball, straight and breast-high. The Blue line plunged gallantly. The stand became a pandemonium! The full-back swung a long right leg, but the ball did n't drop from his hands. Two steps to the left,

and he was poising it for a forward pass! Then he threw, well over the upstretched hands of a Hillman's player who had broken through, and to the left. A Maroon-and-White end awaited the ball, for the instant all alone on the Blue's goal-line. Ned, seeing, groaned dismally. Then from somewhere a pair of blue-clad arms flashed into sight, a slim body leaped high, and from the Hillman's side of the field came a veritable thunder of relief and exultation. For the blue arms had the ball, and the blue player was dodging and worming toward the farther side-line! Captain Stevenson it was who cleared the path for him at the last moment, bowling over a Farview player whose arms were already stretched to grapple, and, in a shorter time than the telling takes, Kendrick was racing toward the distant goal!

Afterward, Ned realized that during the ensuing ten or twelve seconds he had tried desperately to shin up the tall policeman; but at the time he had not known it, nor, for so it appeared, had the policeman, for the latter was shouting his lungs out! Past the middle of the field sped Hop, running as fleetly as a hare, and behind him pounded a solitary Farview end. These two left the rest of the field farther and farther back at every stride. For a moment it seemed that Hop would win that desperate race; but at last, near the thirty-five yards, he faltered, and the gap between him and his pursuer closed to a matter of three or four strides, and after that it was only a question of how close to the goal the Blue runner would get before he was overtaken and dragged down. The end came between the fifteen-and twenty-yard streaks. Then, no more than a stride behind, the Farview player sprang. His arms wrapped themselves around Hop's knees, and the runner crashed to earth.

For a long minute the babel of shouting continued, for that eighty-yard sprint had changed the complexion of the game in a handful of seconds. Hillman's was no longer the besieged, fighting in her last trench to stave off defeat, but stood now on the threshold of victory, herself the besieger!

Farview called for time. Two substitutes came in to strengthen her line. Hop, evidently no worse for his effort, was on his feet again, thumping his players on the backs, imploring, entreating, and confident. On the seventeen yards lay the brown oval, almost in front of the right-hand goal-post. A field-goal would put the home team one point to the good, and, with only a few min-

utes left to play, win the game almost beyond a doubt, and none on the Blue's side of the field doubted that a try at goal would follow. Even when the first play came from ordinary formation and Deering

get free and that luck would bring a touch-down instead.

Yet again Hop signaled a line attack. This time it was Mason who carried the ball, and he squirmed through for two yards outside left tackle, edging the pigskin nearer the center of the goal. Then came a shout that started near the Blue team's bench and traveled right and left along the stand. A slight youngster was pulling off his sweater in front of the bench, a boy with red-brown hair and a pale, set face. Then he had covered the red-brown hair with a helmet and was trotting into the field with upraised hand.

Ned stared and stared. Then he closed his eyes for an instant, opened them, and stared again. After that he pinched himself hard to make certain that he was awake and not still dreaming on the knoll beside the road. The substitute was speaking to the referee now, and Deering was walking away from the group in the direction of the bench. The cheering began, the leaders waving their arms in unison along the Hillman's stand:

"'Rah, 'rah, 'rah!  
'Rah, 'rah, 'rah! 'Rah,  
'rah, 'rah! Deering!"

And then: "'Rah,  
'rah, 'rah! 'Rah, 'rah,  
'rah! 'Rah, 'rah, 'rah!  
Turner!"

Ned turned to the policeman. "What—who was that they cheered?" he faltered.

The policeman looked down.

"Turner. Guess he 's going to kick a goal for 'em."



"TURNER. GUESS HE 'S GOING TO KICK A GOAL FOR 'EM'"

smashed into the left of Farview's line for a scant yard, the audience was not fooled. Of course, it was wise to gain what ground they might with three downs to waste, for there was always the chance that a runner might

(To be continued)





# The King of the Turquoise Mountains

by  
Tudor  
Jenks

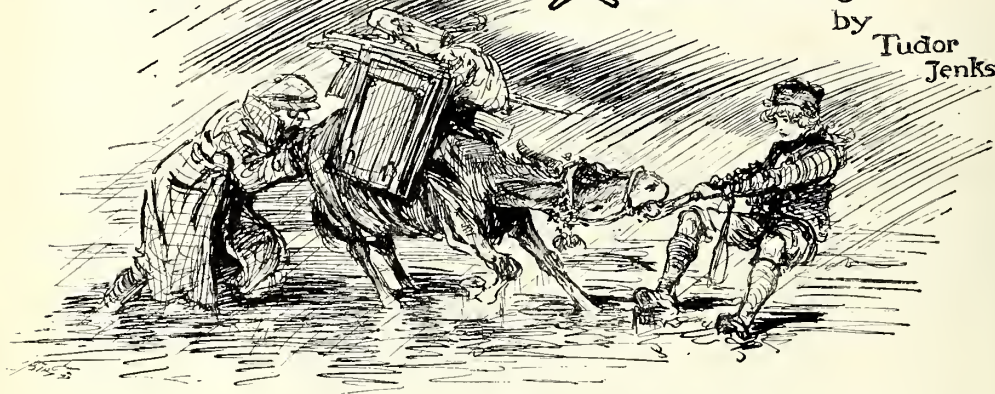

YOU remember how quickly thunder-storms come up in the Turquoise Mountains? One hour there will be clear blue sky, with no sign of a cloud, and then the thunder-heads rise above the horizon, like giants peeping over the edge of the earth—and down comes the rain in sheets!

Then one takes to his heels for the nearest shelter.

That is how I came to visit the palace of the king, three or four years ago, during a sketching-trip among the higher levels of those superb mountains.

Before I came to the palace, I had plenty of time to be soaked through, for though I and the peasant boy who drove my pack-mule could have reached the palace gates before the storm broke, the mule was in no hurry at all. He kept to his slow walk, even though we pulled at his bridle and pushed from behind, and took his time and ours.

When the rain fell fastest he paid no attention to it except that he lowered his ears in a discouraged way. So we were sopping wet when we came to the outer gates and pounded loudly for admittance.

I don't know that we should have got in, except for a lucky chance. It happened that His Royal Highness himself, Fantom the Fifth, had been out at the golf-links that afternoon (for the newspapers that morning had said the weather would be "fair and

cloudless, with mild southern breezes and a rising barometer") and, like ourselves, the king had been caught by the sudden storm.

When he came to the gates he cried out, "What ho! Open up, warder, and get thee to it!"

At the sound of the royal and commanding voice, the gates flew wide apart, and we all (except the mule) rushed through the courtyard, over the graveled path, and in a moment found ourselves under the porte-cochère of the palace, shaking ourselves dry as if we had been shaggy dogs just out of a river.

"This," said the peasant boy, "is His Majesty Fantom the Fifth," bowing before the royal presence.

I did my best to be elegant, and bowed low—causing a stream of water to pour out of the brim of my hat.

"Whom have I the pleasure—" the king inquired, as he nodded in response to my greeting.

"Only a wandering artist, sire," I answered, "trying to depict the beauties of your mountainous realm. I was caught in the rain—"

"Yes," said the king, drily, "so I see. I noticed that the weather was damp." And he handed his outer wraps to the footmen, who by this time were coming to his assistance. "Well, well—we're under cover now. I'll be glad to lend you some dry garments—and also to have your company at dinner,

Afterward, I would like to look at your paintings, and probably I 'll buy a few—for I really have nothing particular to spend money on. Run away, now, and meet me in the dining-hall at six."

So, under the guidance of a footman, I was taken to the blue guest-room, where I had a choice among the king's old uniforms to replace my damp clothing.

When dressed, I strolled to the window and saw that the peasant boy was slowly, but surely, persuading the mule to come in out of the wet. Apparently that mule loved to be in a shower-bath, for he resisted at every step across the courtyard. But the plucky boy succeeded in getting the mule into the royal stables just as a melodious cathedral clock chimed out the hour of six—the dinner-hour.

I went downstairs; but being unused to the palace, I must have taken a wrong turn, for I found myself in the kitchen—where I saw the peasant boy making a good meal and being looked after by the plump royal chef, who piled his plate with dainties.

"How 's the mule?" I asked jokingly.

"All right," the boy replied. "He 's only happy when he 's miserable—but he 's having his fill of fodder and pretending to be sad about it."

"We're lucky to find so pleasant a shelter," I remarked. "I hope you 'll be comfortable. I am going to dine with the king."

"As the queen is away, you 'll have a pleasant time," said the chef. "She 's not so easy to get along with as the king. He does n't care what sauces I give him. She always wants more sugar, or less vinegar, or no curry, or fewer cloves—or something different. You take this door for the dining-hall," and he showed me the way.

I found the king already seated, and he pointed to a chair next him. We dined to-

gether without other guests, and had an excellent meal—turkey-wing soup, fried dolphin, tamarind fritters, buffalo ribs, bamboo salad, four fancy desserts, and so on.

Then we had a pleasant talk, wherein the king told me some of his troubles.

"You know what it is," he began. "As you see, I am sovereign of this distant and mountainous land, and I would be able to live comfortably and at ease except for the unfortunate fact that my nearest neighbor, King Nabob the Ninth, who reigns over Prestigalia, has a daughter who is the most beautiful princess in the world."

"Why do you mind that?" was my question.

"Because King Nabob is also anxious to possess a celebrated gem which—I don't mind confessing between ourselves—my father took from his treasury some ten years ago. You see?"

"Not exactly," I admitted. "Not yet."



"SHE 'S NOT SO EASY TO GET ALONG WITH AS THE KING"

"Why, whenever princes come to court his daughter, Princess Sapphira, he always makes it a condition that the prince must first bring him the Great Blue Sapphire as the price of his daughter's hand. You understand?"



"And that is the celebrated gem your father stole—"

"Yes—*captured* from him. I have that wonderful gem carefully locked up and guarded in my strong room."

"And I presume you object to handing it over."

"Precisely. But those princes are an almost daily nuisance. We find them everywhere. They come disguised as peddlers, as jewel-merchants, as cooks, as locksmiths. They come in full battle-array with armies; they get all sorts of magic charms and amulets; they are helped by necromancers,



"'PARDON ME,' HE SAID, 'BUT ARE YOU A PRINCE, BY ANY CHANCE?'"

witches, learned pedants, and mighty giants. Why, the whole palace is guarded by burglar-alarms and special watchmen at twenty bezants a day! That is why the queen gets away from here whenever she can find an excuse. She is visiting a second cousin now—and won't be back for two weeks. She says: 'Give Nabob the sapphire, my dear. You know he won't be happy till he gets it—and neither will you!' And I sometimes think she is right."

"It seems to me she is very wise," I could not help saying. "I expect to visit Pretigalia next week. Suppose you let me take the Great Blue Sapphire to King Nabob—"

King Fantom frowned and looked at me with sudden suspicion.

"Pardon me," he said, "but are *you* a prince, by any chance?"

"Not even a viscount," I hastily assured him, and I took my passport from an inner pocket (for I never part with it) and convinced him that I was only Thomas John Tompkins, a humble American artist, of Tompkinsville, Montana.

"I trembled for a moment," the king admitted, as he returned the passport, "though you don't look like a prince, exactly—in those big eyeglasses of yours. You remind me of a pet owl of the queen's—now dead; but you're better looking, in some ways—"

(This was merely his politeness, I am sure.)

"These adventurous princes come at all times," King Fantom went on, munching a bit of celery, "and surprise me, even though I always am told when new suitors come to King Nabob for the hand of Princess Sapphira. This week, for example, there are three brother princes, named Abel, the eldest, Bertram, the next in age, and Cadwallader, the youngest, who have undertaken the task."

"Abel, Bertram, and Cadwallader," I repeated. "That must make you uneasy."

"It does," he admitted. "But we fixed Abel only this morn-

ing. He arrived with a troop of lancers. But the watchman on the south tower discovered them, blew his trumpet to call my men to arms, and we drove them out of the country in less than an hour. So that fixed Abel. I suppose we'll have a call from Bertram along about noon to-morrow or the day after. Not that I have much fear of Bertram—for he's only the *second* son. It's the *youngest* son that always succeeds in the fairy stories, you remember!

"Now let us go up to the art gallery, where I'll show you the portrait of my father—the one who captured the Great Blue Sapph—"

He stopped, for suddenly a hundred jangling bells rang out—including a great brazen gong that went "Boom—boom—boom—boom."

King Fantom sprang to his feet, crying out: "The alarm! Follow me! That must be Bertram. What a nuisance!"

He rushed up the great stairway, I following close at his heels, and led me out upon the top of the great watch-tower.

The air was filled with airplanes that were darting about like a flock of swallows, and gradually circling nearer to the palace.

"Quite modern of Prince Bertram!" King Fantom exclaimed. "But, luckily, this is one of the things the Minister of War, Lord Feitum, has planned against. Just watch me!"

me) they were bad work artistically—bad in drawing, weak in color, absurd in values, framed in wretched taste, and hardly worth looking at. Before the king had a chance to ask my criticism, the Commander of the Air Force came to make his report.



"AS HE FLEW OVER THE PALACE WE HEARD HIM CRY OUT: 'THE YOUNGEST SON SUCCEEDS'" (SEE NEXT PAGE)

"Lord Feitum's plan worked perfectly," said the chief aviator. "We threw steel nets over their propellers, and they had to take to earth on long glides. I have the honor to report that we won a complete victory."

"Good! You are decorated with the Order of Highflyer Royal," said the king, "and your salary is doubled."

"Long live the king!" cried the chief aviator, and he saluted and retired.

"So much for *that!*" the king observed. "We have now settled with Abel and Bertram. I hope that Cadwallader will wait till morning, at least. For I should like a good night's rest. Do you care to see any more of the portraits, Mr. Tompkins?"

"Why, no," was my response. "You see, as an artist, pictures rather bore me—that is, pictures by other artists, you know. But I should n't mind—if you're entirely convinced that I'm not a prince and am only naturally curious—seeing that Great Blue Sapphire. It must be an exquisite gem!"

"It is a wonderful jewel," the king boasted, "and I'm glad to have somebody see it. Come with me to my treasure-room. I always carry the key on my person. I'm delighted to have got rid of Prince Bertram—for Prince Cadwallader could n't interfere till his elder brothers had failed in the task."

We went down a corridor and came to a



He went to an electric switchboard and touched several of the keys. I could hear new bells clanging around me, and really it was hardly more than twenty minutes before a second fleet of airplanes arose from the top of the palace and soared out to drive away the attackers. The defenders were larger and swifter than their foes, and put them to flight. As the whole group receded into the distance, I could see that Prince Bertram's planes were one by one driven to earth.

We descended into the art-gallery and looked at the portraits. They were good likenesses, perhaps, but (between you and



door with massive hinges and locks, where the king halted me. Then he produced the key and swung wide the unlocked door.

"The gem is in this box," he announced, taking a golden casket from a shelf.

I watched eagerly as he opened the cover, and within, on a satin cushion, shone the Great Sapphire, like a marvelous blue planet with a soft cerulean luster.

"Is it not a wonder?" the king observed.

"Most exquisite!" I exclaimed. "You can not be *too* careful—"

Just then came a cry from outside, and the king jumped.

"Cadwallader!" he murmured.

"No," said I, "it 's only my mule-boy," for I heard him crying, "Oh, Mr. Tompkins! Oh, Mr. Tompkins!"

So I turned toward the door saying, "Here I am. What 's the matter?"

The boy rushed in. "It 's the mule, sir. There 's something queer about him!"

The king and I came toward him, and suddenly—how could I foresee it?—that wretched boy snatched the golden casket and the Great Blue Sapphire from the king's hand, and sped away down the corridor.

We went after him at top speed, but he was far too fleet for the king and myself. We came to the palace doorway only in time to see him mount the mule—*who had sprouted a pair of wings*—and soar into the air!

As he flew over the palace we heard him cry out:

"The youngest son succeeds!"

King Fantom ordered up his guards and

sent me into a darksome dungeon—where I spent two or three dark and dismal days. Fortunately, the queen then returned to the palace and granted me an interview. I found out that she was a cousin of the Parker-Greens of Tompkinsville, and soon convinced her that I had been entirely innocent in the whole matter. Then she interceded with the king, sold him two of my paintings, and sent me away with very gracious messages to Mrs. Parker-Green—who had been a school-fellow of hers in Montana.

After some time had elapsed, I made a visit to Prince Cadwallader and his royal bride Princess Sapphira, who was wearing in her tiara the Great Blue Sapphire. She was lovely.

"How about the King of the Turquoise Mountains?" I inquired.

"It is all right now," said Prince Cadwallader. "His queen is glad he got rid of the Sapphire,—that his father stole, you know,—and she has had all the burglar-alarms taken out of the palace. And, by the way, the chef is now my chief cook."

"King Fantom's chef?"

"Yes. He was an enchanter in my employ. He lent me the Winged Mule."

"Is n't he clever?" said the Princess smiling.

"The enchanter?" I asked.

"No."

"The Mule?"

"No."

"Who?"

"My Prince!" she answered.



"IS N'T HE CLEVER?" SAID THE PRINCESS SMILING"

# THE KEY

By BETH B. GILCHRIST

*Author of "Cinderella's Granddaughter," "The Camerons of Highboro," etc.*

THERE were a great many books in the room, books of all shapes and sizes and colors, books with pictures and books without, and they were nearly all garden books. That was odd, for the girl in the room was not a gardening girl. She was not any kind of an outdoor girl. She was pale and sat still or moved listlessly. There was not the least bit of spring in her. That was why, she would have told you, the books were all garden books. She liked out-of-doors, but because she could n't run or jump or tramp or climb or fish or play tennis or golf or paddle or do any of the things girls do out of doors when they move rapidly about from spot to spot, she did n't like to read of such activities. She preferred, she said, to read about out-of-door things that "stayed put" in one place. They might grow; that was to be expected. But growth was a quiet kind of activity that you could n't possibly make out while you were looking.

So she read about gardens—big gardens, little gardens, rock gardens, water gardens, gardens that spread in beauty over a landscape, and gardens that stayed restricted within the confines of one small back yard. There was n't much about garden-making that Beverly Adams had n't read about. And there was nothing at all in garden-making that she had actually done. It was several years ago that Beverly made up her mind there was nothing much for her to do, anyway.

From the window where she sat in cushioned lassitude, she could see, between tree branches and over a low brick wall, a riotous place of green things gone wild and fighting each other for ground space. Nobody lived next door; nobody had lived there for years. By contrast, the Adams place was amazingly trim and tidy and shorn. The Adams place had no garden—none, that is, to speak of. It had not occurred to Beverly to wish for a garden; if she had, one would have been provided. When your active world is bounded by the possibilities of a wheel-chair and a motor-car, there are certain enterprises that appear out of reach.

As the girl sat looking out of the window, a maid brought in the mail. It consisted for Beverly, this April morning, of a single letter.

The letter thickened at one corner into a fat, hard lump. That was a trifle strange, for the handwriting was Aunt Madeline's and Aunt Madeline was very particular about letters. She liked them immaculate and perfectly folded, and her writing, though illegible, was distinguished looking.

As Beverly opened the envelop a twist of gold-colored tissue fell out in her lap. The note itself was surprisingly short.

Bev, dear, what this unlocks is yours. Make what you can of it.

AUNT MADELINE.

Beverly unfolded the gold tissue. A curiously wrought iron key lay in her hand. Not a new key—obviously, this key had been in use for years. What could Aunt Madeline mean? Aunt Madeline always meant something.

After she had stared at the key for five minutes she touched a bell.

"John," said the girl, to the man who responded, "have you any idea what this key unlocks?"

The man turned it over and over critically in his hand. "No, Miss Beverly. I never saw it before."

"Aunt Madeline sent it."

"I was hearing this morning that Miss Adams has bought the place next door, miss."

"Craig House?"

"So they're saying."

After John had gone, Beverly leaned forward and surveyed Craig House wonderingly. What could Aunt Madeline want of it? Was n't the Adams house big enough, with only a girl in it steadily all the year round, and Father darting back now and then from New York or Chicago or anywhere else business might take him? But now, Beverly supposed, she would some day see what the Craig place looked like on the inside, though she was n't quite sure that she wanted to see. Ever since her littlest girlhood, Craig House had been the home of Beverly's dreams, largely, she knew now, because of its mysterious, neglected air and the fact that it was barred to her. But what, in the name of all weirdness, could a key like that in her hand unlock at Craig House?



"Aunt Madeline's bought the Craig place, John says," Beverly remarked when her father came upstairs for the after-dinner chat he never missed when he was at home.

The man laughed. "Against my advice. What does she want it for?"

"To live in?"

"Not this summer. She's going to Alaska."

"Perhaps, just on general principles, she thinks it has been shut up long enough. Is she putting servants in?"

"Not in the house this season. The grass is to be cut and the place kept in shape outside. That's as far as her orders go. And you're to have the run of it in your chair."

"I don't know that I care much for that."

"Any orders you give are to be honored. Know what she means by that?"

"Orders I give? Why should I give orders?"

"Search me," said the man. "If *you* don't know, I can't enlighten you. She's engaged a man and a boy for the season. If Madeline cares to sink money that way, it's her own affair, I suppose."

"How odd!" said Beverly. "Has n't she explained anything?"

"Nothing at all."

It was the mystery of the matter that held Beverly's imagination. She could n't help wondering, since it was impossible to find out, why Aunt Madeline had made such strange disposition of her new property. In the course of two days the puzzle drove her wheel-chair through the gates of Craig House and, with John at her back, along moss-grown brick pathways.

At the rear of the grounds was a door in the brick wall that had grown higher as it receded from the street until now you could see over it nothing but tree branches.

"Where does that go?"

"To the other street, Miss Beverly."

"It can't," said Beverly. "We're not far enough back for that. Look at our place, if you want to prove it."

John tried the door, but it was locked.

"I don't know, then," he said. "A clothes-yard or something of that sort, most likely."

"We passed the clothes-yard," objected the girl.

That night Beverly slept uneasily. It was absurd to wake up and wonder what lay behind that high brick wall, absurd to connect it with the key Aunt Madeline had sent. But the next day the order to John was brief and explicit.

At the door in the wall the chair paused. "Try this." For a second of unwonted energy she wished that she could do it herself. "Now wheel me in."

It was very quiet in the secluded place and utterly private; certain, too, to be lovely when the trees and vines were in leaf. Already patches of crocus brightened the grass. Why, it had been a garden once! "What this unlocks is yours—make what you can of it." But was n't that a bit stupid? Aunt Madeline was n't usually stupid. How, under the circumstances, could Beverly make anything of it? And something *could* be made of it. As the wheel-chair explored the place, Beverly saw that at once. She had n't read and studied pictures so much, not to realize the possibilities of charm and beauty—nodding daffodils under the trees; larkspurs spring against the high walls. Nonsense! For once, Aunt Madeline must have been crazy.

But that did n't end the thing. Odd, how the walled garden persisted in Beverly's imagination. She kept thinking of things you might do in it, if you were like other people with properly functioning feet. But always she thought of them as unattainable.

And then came another letter from Aunt Madeline. It simply said, "Bates and Richard will take their instructions from you. Draw on me for whatever you need to order."

Beverly simply laughed when she read it. How absurd of Aunt Madeline!

But when one day a bent little man with crooked brown fingers and a round, brown, blue-eyed face presented himself before her, cap in hand, as John pushed her chair through the Adams grounds, the absurdity grew too pointed to ignore.

"What will you have done, miss?" jerking his thumb in the direction of the wall. "I'm Bates, miss."

"Oh!" said Beverly. "I—why, nothing. I'm not giving orders. I have n't anything to do with it."

The little bent man looked puzzled. "That's orders, miss. 'Ask her,' she says."

"She made a mistake. I mean, I can't. Don't you see I can't?"

The little man ruminated. "'Take care o' that walled place all summer,' she says. 'Do as she tells you to.' Now if you ain't tellin' me nothin', what be I to do about it?"

"I don't know, I'm sure," said Beverly. "What you like, I suppose."

He nodded briskly. "Sure, miss. That 's it, miss."

Beverly hesitated, watching his departing back. Then she halted him. "Bates! Bates! What are you going to do first?"

The little man had no hesitations. "Plow it up," he said, "an' grade it nice an' lay out

ing. One morning he started to dig out the crocuses—"to tidy the grass up." It was after that that Beverly began to come early to Craig House; she must, she foresaw, spend her days on the spot.

The crocuses introduced her to Richard. She had seen Richard before, spoken with



"WHAT WILL YOU HAVE DONE, MISS? I 'M BATES, MISS'"

some proper beds. I can get that fur without no directions from nobody."

"No!" said Beverly. "You must n't do that. It would spoil it."

Bates bristled. "I 've laid out gardens an' took care of 'em for forty year, miss."

Beverly eyed him. He meant it. He would do just that—plow the place up!

"John," said Beverly, "wheel me over."

So, quite against her will, she got into it. It made her a little cross to think that she had to get into it. But she could n't let the place be spoiled, could she? She shuddered to think what Bates would make of it, left to himself. As it was, one had to watch him—one had to watch him all the time. He thought up such curious things to do that it never had occurred to one to forbid him do-

him—a tall boy who spent his out-of-school hours toiling under Bates's direction. It was Richard who on a Saturday had saved the crocuses. He had come to the Adams house and asked her about them.

"Do you want the crocuses dug out of the grass?" he had asked.

Beverly laid down her book.

"Of course not!"

"Then perhaps you 'd better come over. Bates is getting to work on them."

"Digging—them—up?"

The boy nodded. "Bates," he ventured, "has a tidy eye."

"Thank you," said Beverly. "I 'll be right over. Oh, mercy! John 's gone for half an hour. I forgot."

"I 'll wheel you."



"Quick!" she said. "Will you hand me that coat? I'll not stop for a hat. Hurry, please."

That was the beginning of her friendship with Richard. For it was friendship. Richard spoke her language; Bates did n't. Richard knew how she would like things; he liked them that way himself. And Richard was young. Beverly had forgotten what it was like to do things with some one who was young. The people who surrounded her had been grown-up for a fairly long time. Girls called now and then, punctilious, sympathetic girls, who came to "cheer" her and were very careful what they talked about. She took girls with her on her motor-rides, girls who chattered of dances and tennis and basket-ball and everything Beverly was shut out from. With neither sort of girl had she anything in common. With "Dick" she had the garden. It was amazing how interesting it was to have an interest in common with some one who was young.

And Dick wanted to have the garden grow the way she wanted it. Bates did n't. Bates had his own ways and grumbled not a little at new ones. Beverly fell into a sort of partnership with Dick against Bates. Dick would do anything she asked, readily and energetically and intelligently. Bates growled and held back.

"Oh, Dick," said Beverly,—it was mid May and they knew each other fairly well by this time,—"I never should be able to put this thing through without you!"

Dick, spading in the irregular border Beverly had designed against the surrounding wall, chuckled. "Oh yes, you would. He does n't make it easy though, does he? But you 're the pluckiest girl I ever saw. I'd bet on you to put a thing through, if you set your mind on it."

Beverly's eyes opened wide. "I—*plucky?*"

"Sure," said Dick. Then he went on spading.

Beverly, watching the steady rhythm of the dip and lift of his fork, liked what he had said, but she thought it was n't true. Dick had mistaken for courage the fact that she did n't "fuss." And she did n't fuss, merely because she had come to accept as inevitable the fact of sitting still in a chair and not walking. Turning the pages of her garden catalogues, suddenly Beverly began to feel as though she might like to fuss. But if once she let herself wish to walk, it would make her very unhappy,—would n't it?—since she

could n't walk. Resolutely she turned back to her tulip lists. She was deciding what bulbs to order for planting in the fall.

It fascinated Beverly to plan the garden and then to superintend the planting of what she had planned. Matters of soil, Bates knew about, though even here Beverly's reading had made her intelligent. Dick frankly took orders. It was n't his business to understand obscure matters of fertilizers and tillage; he was going to college in the fall. Dick had n't much money; that was why he worked out of school hours. He meant to earn his way in the world. Sometimes the two talked of what Dick was going to do. That interested Beverly almost as much as planning the garden.

And then one day she spoke out. "Oh," she said, "I wish I could walk!"

Aunt Madeline would have known how much that meant from Beverly. Dick did not. "Can't you—sometime?" he asked.

"I don't know." Beverly was surprised, when she thought of it, to find out how little she did know. "I have n't—oh, for ever so long."

Dick came over and stood by her chair and looked down at her. Dick was very tall, and there was a look of keen interest in his eyes. "See here," he said, "why don't you ask your doctor whether it would do any harm to try?"

Beverly gasped. "Why, I—I will. But of course I know what he'll say."

"Golly," said Dick, "would n't it be great if you could walk!"

"Walk?" said the doctor. "Er—ah—I don't know about that. I might use some long words, but I won't. I can't promise you anything. And I would n't, if I were you, begin to hope. If you want to walk hard enough—but even then, there's no certainty."

"If I want to—"

"It's partly a matter of will in such cases—not entirely, understand. Partly."

Beverly told Dick. "You're the only one that knows," she said. "I don't want people asking how I'm getting on all the time, not even Father. I'm to have more massage, you know, to begin with, to get the muscles right."

"You've got will enough," said Dick.

"I don't know," said Beverly. She was wondering what it would be like to step out of her chair and walk over to where Dick knelt and hand him the next plant for the row he was setting. All at once she desired

passionately to feel earth on her fingers. It would be fun to dabble with a trowel. Her hands were too soft, too white.

"Dick," she said suddenly, and for the first time since he had known her the girl's

outside, and left the place to Dick. "New-fangled notions," Bates said. Only, for baseball, Beverly insisted that Dick take hours off. Somehow she had discovered that Dick was a star of the local nine.

"You can work earlier or later on such days to make up, if you like," she told him. "You ought to have some fun; and does n't the team need you?"

Dick laughed. "So the fellows say."

"That settles it."

The boy liked the girl's autocratic little air; liked, too, her consideration. Dick had seen enough of invalids to know that such thoughtfulness is not always the rule in people whose life has wanted them to continual waiting on. But Dick never thought of Beverly as an invalid. Although he thought of her differently from any girl that he had ever seen before, it was never as a creature handicapped and shoved aside; always as a sound, real girl, but a girl who, as it happened, could n't walk.

As summer advanced, Beverly essayed, once, twice, to stand on her feet. She tried it at home in her own room with the doctor and John to help her. It did n't work. It frightened her to find how com-

pletely it did n't work. For now she wanted to walk—oh, tremendously! She could n't quite see how she was going to live without walking.

"You can't expect to step right off the first time you try," Dick comforted her. "I'll bet you're afraid, all the time you're trying, that you can't do it."

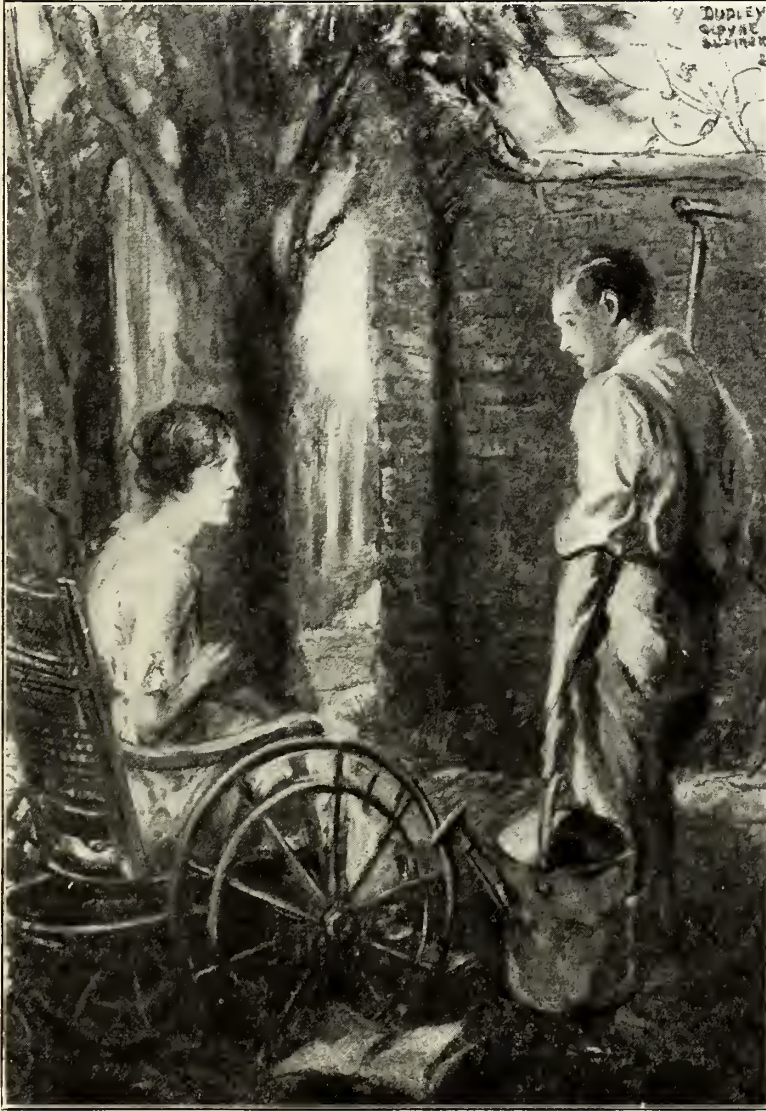

"'WOULD N'T IT BE GREAT IF YOU COULD WALK!'"

voice was strained, "Dick, do you think I'll ever do it?"

"I'll bank on you," said Dick. "If it's a possible thing, you'll do it."

So summer came, and, with the end of school, Dick was in the garden all day long. Bates did n't like the garden; he shook his head over it, worked as much as he could



"Oh, I am!" said the girl. "How did you know?"

"Guessed. You 've got to stop being scared. Then some day you 'll do it."

"It does n't help any," Beverly told him a week later.

Dick stopped setting irises.

"You've tried again?" His voice was eager.

She nodded. "Yesterday. I vowed I would n't be scared, I 'd believe I could do it. I set all my will to keep from thinking about being afraid. I could n't."

Tears gathered under the girl's lashes, but they did not fall. Dick saw them. "See here," he said, "you're going to do this some-time. Don't you get discouraged. You've got to keep everlastingly at it. If—" He hesitated.

"If what?" she prompted.

"If somehow you could forget whether you were scared or not—just step right off without thinking."

"It sounds easy," she said, "till you try it. I think I *am* getting discouraged, Dick."

"Never say die," he adjured her. "'Pike's Peak or bust,' you know."

"'Pike's Peak.' This place is going to be lovely next year, Dick."

"When I come home from college next year," he said stoutly, "you 'll be walking all around in it."

"Shall I?"

"Of course you will."

But Dick's heart was heavier than his words. It was odd that for a girl who bore no relationship to him except that of "boss" his heart could be so heavy.

BEVERLY was never able afterward to relate how it happened, and Dick, obviously, could n't tell. Dick was n't paying attention to any one when it happened.

"There 's a branch on that maple that ought to be cut," he had said to Beverly half an hour earlier. "It crosses the next. See where the bark 's worn?"

"You want to leave everything just right, don't you?" said Beverly. She was wondering how she was to get through the days when Dick was gone.

"Sure," said Dick, and went for ladder and saw.

Then he wheeled Beverly's chair out of range of the branch that was to fall and bounded up the ladder. Beverly, watching him swing from limb to limb through the tree, thought it would be wonderful to climb like that, to be so free and sure and unhampered. Dick braced himself on a horizontal branch and reached up with his saw to make the cut.

The limb he was standing on must have been rotten; later examination proved that it was rotten. In Beverly's ears sounded a rending snap and crash; before her eyes the boy's body shot downward, clutching vainly in his fall for support. Then Dick lay very quiet, huddled on his face in a litter of leaves under the tree.

The next thing Beverly Adams knew she was kneeling beside him. Of how she got there, she had later no clear recollection. Tugging desperately, she managed to get the branch away and roll the boy over on his back. The first thing to do was to feel for his heart, was n't it?

Dick opened his eyes and looked up at her. "Hello! took a tumble, did n't I?" He struggled to sit up, and realization flashed suddenly into his eyes. Then he did sit up.

"Gee-whiz!" he cried joyously, "You've done it!"

"Why, why I have!" she said, and plumped down beside him on the grass.

## THE TWO CLOCKS

LITTLE clock, ticking all day long,  
What are the words of your endless song?

"One, two, three and four and five,  
"Hurry, hurry, hurry while you are alive."

Great clock standing stiff and tall,  
What do you say in the darkened hall?

"Five and six and seven and eight,  
"Take your time, you 'll not be late."

Little clock, big clock, which is true,  
How am I to know what I 'm to do?

"Hurry when you 're little," "And learn  
to be  
Old and steady and sedate like me."

M. D. Cole.

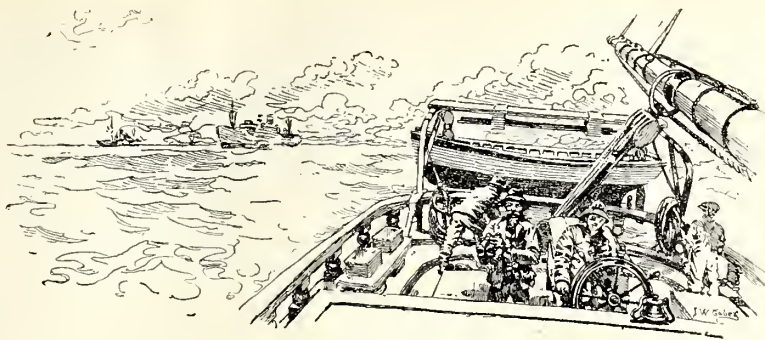

## IN THE BLOOD

By KENNETH PAYSON KEMPTON

### PART I

EVEN Waite, the general manager of the Line, came down two hundred miles by rail for the launching of the *Etta Deering*. In itself, that showed the importance of the occasion: for Waite was a man who seldom left his desk—never left it, in fact, for anything less than about a hundred thousand dollars. Why should he? On the fifteenth floor of the Mutual Building, commanding docks and the whole sweep of the teeming lower harbor, he had under him a young army of men and women,—clerks, messengers, bookkeepers, stenographers, 'phone and wire and radio operators, assistants of every breed and description,—whose express function it was to keep his desk nourished with every minute current fact bearing upon the Line, its ships, above all else, its freight. Come to think of it, a hundred thousand dollars puts the situation mildly.

Yet on Friday night Waite caught the Bar Harbor Express. And the next morning, refreshed by a hearty breakfast and the change of air, he registered unostentatiously at the Eagle House in the little town of Westport.

"I suppose you 're wondering," said Waite, to Old Man Latham,—who was to be the *Etta's* skipper,—"I suppose you think it sort of odd that we should set so much store by these new wooden bottoms. Eh?"

"I would wonder some," returned the grizzled seaman slowly, "ef it was anyways my business."

The manager laughed. "No one could blame you, Cap'n," he continued. "The Line has never bothered much with sailing-ships—you know that."

Waite paused, as if expecting some com-

ment. But Henry Latham had ever been a silent man. He was looking quietly out the window of the Eagle House lobby at the new white spars of his schooner, at her stout oak planking, at all the magnificent rounded lines of her. Something like tenderness lurked in the corners of Latham's wind-swept eyes. And he said nothing.

"But now we 've got to," went on Waite. "Coal is high and getting scarcer every year and month. A ten-thousand-ton steel ship takes a crew of fifty men—wharf-rats, union men, high-priced loafers. A three-master like the *Etta*, there, needs only twenty. And we can find 'em right here outside the yard, just as you 've picked up your crew in two or three days—clean and home-raised men, who 'll work honestly for an honest wage."

Still Latham held his peace.

"And another thing, another argument for sailing-vessels—is robbers, thieves—"

The man looked up at last. He turned his head from the window and bent those weather-beaten eyes of his full on the dapper little manager beside him. "Thieves?" he growled.

"We 're losing thousands every month." Waite nodded as he spoke. "Part of it is dock work—but not all. The Cherbourg boat—she came in last week almost fifty cases shy. We can't watch 'em properly on a big steamer—there 's too much room to hide. And somehow, since the war—" Waite leaned over the table close to the big man's ear, and looked guardedly about the room. "We think, down in the office, there 's some big system been organized since the war. We 're building schooners strictly for economy just as fast as we can build 'em. And to every master I have the



same thing to say," once again the manager looked around the room: "*There's a hundred-dollar bonus for every perfect manifest.*"

Captain Latham looked back again, out of the window at his vessel. For a long time he was silent; then finally he spoke, weighing every word as it left his tongue.

"I see just how it is," said he; "and I'll guarantee you this, Mr. Waite—that for every time I cross the ocean you'll pay me, besides wages, one hundred dollars."

"Fine, fine!" said the manager, rubbing his hands. "Let's go down and look her over. I must catch that twelve o'clock back to town. But we'll have time for a little chat first. And all the final arrangements can be made in the office, when you get there. You've negotiated for your ballast?"

"Yes," said Latham. "We'll tie up to the dock here after the launching. They're going to give us sand—I've always liked that best. I'll be ready to leave by the middle of the week."

"That's good. I'll have your cargo ready. It'll be wheat and steel mostly—possibly some furs—for Bordeaux."

"All right," said Captain Henry Latham. "Don't forget—that hundred-dollar bonus." "Not likely!"

THAT night a great hulk of a boy hung around his mother's kitchen while she got the supper ready. He had seen the launching from one of many crowded roof-tops. And the glory of the *Etta's* first lovely plunge still kindled a reflective fire in his clear and light blue eyes.

"D'you think it'd be any use—askin' him again?" he said.

"Oh my gracious, Sam, I don't hardly think so. Your father's got a lot to think about, these days, and you know, well's I do, that he's dead set against it. Turn those potatoes for me—you're right handy. He'll be here any minute now. Why don't you try to be satisfied? You've got a good job down to the store. How was the la'nching?"

The boy seemed not to hear her last question. Dutifully he turned the potatoes in their pan. Then he stood idly by the stove, staring through the window at the harbor below. Quoddy Light was winking its red eye across the shoals.

"I want to go to sea," the boy said doggedly.

Mrs. Latham's head was in the flour barrel. From it her tones came muffled

and hollow. "Just look at that Rafe. He's doing so well in the garage over t' the harbor, they say he'll own the business inside of ten year. And you—moonin' around here, not satisfied with the good job your father got you. What body'd ever think you two was brothers?" She appeared from the pantry, smiling good-naturedly, a smear of flour on her nose.

Sam did not look around though. He was still staring out upon the darkling water between Cabbage Island and the Light. His lips moved slowly, but no sound came from them. To himself he was repeating, "I want—to go to sea."

Rafe came in then, a little, wiry young man in his early twenties, with a sharp furrow between his eyes. Truly it seemed, as Leila Latham put it, impossible that these two were brothers. For Sam was big—broad-shouldered like his father. His head had the same lift to it, as if braced against a making wind. And the same sea-wrinkles clustered about his eyes. Rafe's wrinkles lay upon his forehead and about his mouth. In another year or so, he would look forty; while Sam, two scant years his junior, passed for eighteen and was still called "boy."

Rafe came in and launched into eager discussion of the shop. His mother regarded him with a large approval, seeming to welcome the eager technicalities with which his remarks were sprinkled; and she hastened to get a basin and towel and soap ready for him. For Rafe's face and hands were smutched with engine-grease, and the house was spotless.

Sam was still standing by the window as they heard the gate outside click shut, and his father entered the room. The old man paused just inside the door, looking at his younger son.

"Mooning again?" said he.

The boy came to himself with a start. He turned in confusion and stumbled up the kitchen stairs to his attic room. Down below he heard them laughing genially together. In all probability it was at that moment that he made up his mind—perhaps not definitely at that moment, but at least he saw his way.

"Sa-am! Supper!"

Down he went again, through the kitchen to the dining-room, with its red-figured table-cloth and bay-window filled with blossoming geraniums and Wandering Jew. Already they were seated around the table, in the warm circle of light cast by the big

brass lamp hanging from the ceiling. The captain was talking, slowly, as was his wont; Sam tiptoed to his chair.

"—it looks to me like the old fore-and-afters would come into their own. Mr. Waite was down here to-day for the launching. I'm to go up to the city and load for Bordeaux, soon as I get my ballast. The Line's a-building schooners just as fast as they can—and all for transatlantic jobs."

"Why?" said Sam.

His father looked up from his food, and hesitated before answering. Then; "Cheaper," he said shortly; "and safer."

"Safer?" This was from his wife. She was peering at him over the thin gold rims of her spectacles. Latham laughed.

"Don't worry, Mother. Safer on the cargo. Waite says there's some sort of international gang started that steals ocean freight on both sides the water—and in the middle. Big open holds and clear decks of a three- or four-master hinders 'em—there's no room to hide. And the crew's more apt to be homefolks, the kind you can't bribe."

"Well, well! I'm sure I don't know what we're a-coming to. Seems like the world is getting wicked every day."

"There won't be much wickedness along- aboard the *Etta Deering*. I'll lay to that right now." On the last word the captain's big hand struck the table edge.

Sam looked at his father sideways. "Crew full?" he asked carelessly—then held his breath.

"No," returned Latham. "No, it ain't. I lack one helmsman. I figured to pick him up in the city. Waite's looking for one."

"Take me along—Dad?"

The expression on the old man's face was exactly as if he had found an unpalatable morsel in his mouth. For several seconds he sat in silence, disfavor ripening slowly into anger. Then the storm broke. His short, considered sentences fell in booming cadence—like distant thunder.

"We've had that out before. You've asked me and asked me, until I'm nigh daft. Years ago your mother and I decided the matter. For Rafe, here—and you. I got jobs for both of you ashore as soon as you got out of school.

"They say Rafe's making good. I'm pleased t' hear it. But you—you're a ne'er-do-well. You would n't be happy if you was *president!*

"Ungrateful—that's what I call it. I know the sea, and I've had enough of it.

Some day I'll give it up myself. My father was a deep-water man, and his father was before him. It's a habit, that's all, and we're a-going to quit right here. You'll work at the job as pleases your mother and me—or you'll get out."

Sam was silent. The older brother brought up the matter of carburetors. This he argued earnestly with himself, to his mother's willing ears. Trouble worried her. She was glad to have Rafe's big success to think about.

The next day Sam went to work as usual. Indeed, he seemed more cheerful than had been his custom. His mother noticed it at once; she remarked the matter to his father—who said nothing. Lem Dodge, the store-keeper and Sam's tireless employer, noticed it too—and Lem was so surprised he forgot to scold.

The morning's job was sorting apples. A big barrel stood behind the counter, on either side of it a box. Sam pitched in, whistling softly to himself; and the proprietor tipped his chair against the back wall and went placidly to sleep.

The barrel was half empty when Sam heard voices in the doorway of the store. He half rose to go and see who it was—customers, most likely, although they were scarce.

But he stopped suddenly. He ducked back under the counter, and after a while the two men strolled across the store until they stood right beside him, until their low voices were right over his head.

Of one thing he was sure—these men were not natives. There was a metallic ring to their speech. They belonged in cities.

One of them had a funny lisp in his voice; and they said the most amazing things:

"What's the dope?"

"How sh'd I know? Finley sent me down to this dump to keep an eye on Waite. Argued he had a vessel here he's danged nuts over. Thinks he's going to put some stuff in her."

"Well?"

"Waite skun back yestiddy noon; an' I'm danged if I know what's next. They's a new ship here belongs to the Line—but she's a schooner! Can't be the one, can it? What you doing here?"

"I ben up t' the Canada line trackin' stuff f' Gookin. He an' Finley's got a new deal on—furs. They's big shipments on the road. This'll be the biggest job yet. He checks the stuff aboard O. K. and right as rain—"

Lem Dodge snored defiantly. Instantly



the voices ceased; and for a while the store was so still you could hear the wood-ticks nipping at its rotten piling. Then the man went on in a guttural whisper:

"Checks the stuff as right as rain—not one case shy or damaged. But Finley, he hires a lighter, and when night comes he shoves her along the outboard side. And one man in the crew he plants t' pass the stuff out a cattle-port. Danged if it ain't a good kink!"

Again they were silent. Then the other said, "What 'll we do?"

"Get back, ye nut. Yer a fool t' come down here watchin' Waite. They's nothing big enough in this dump for him t' bother with. Tell that to Finley."

"Got any cash?"

"Not a red. I laid on the trucks from Machias here. You got any?"

"Nope. Finley give me half-way. He says I can get back on the ballast."

"You said it! At that, it's easier than the ties and trucks. What 'll go first?"

"Dunno. They's several new ones launched. Couple tankers up river t' the iron works. An' this new schooner I was telling you about. An' they's a new steel ferry goin' t' be towed down soon 's they gets the crew abroad. She might be soft. We might—"

Bang! It was Lem Dodge's chair legs hitting the floor. A horse-fly had bitten him on the head, and he came bustling out of the gloom, rubbing the place and pretending suavely he had never been asleep.

"Well, well, gents, what 'll ye hev?"

Sam heard them argue about plug tobacco, then go out without buying. But Lem Dodge's grumbling passed clean over his head. Sam's heart was pounding like a stone-crusher. He smiled absently at Lem's accusation—that he had been asleep under the counter. He whistled blithely through the subsequent scolding.

For the rest of that day and while he lay awake in his little attic bedroom that night, one sentence pounded its way unceasingly through Sam Latham's head. It was an answer to all his questionings. Its urgent impetus gave motive to his vague and troubled longing.

"Finley says I can get back on the ballast!"

There was no doubt in his mind after that. His great desire, even, was transcended by these astonishing developments that had been forced upon his consciousness. The essential need was that he get to Mr. Waite's city office, wherever that was, as quickly

and as unobtrusively as was physically possible. Publicity would lessen his chances for success; delay would be fatal. Singularly, it never occurred to the boy that this essential need dovetailed with his great desire. There was but one thing to be done. With the single-mindedness and careful determination of his father, Sam set about the doing of it.

For two days the *Etta Deering* lay alongside the sand dock, taking ton after ton of ballast into her gaping fore and after holds. By Tuesday night her captain, having measured her draft with his own solicitous hands, pronounced himself satisfied; and at the Latham supper-table the word was passed that the schooner would get away on the first of the ebb, at four the following morning.

This meant extensive and somewhat chaotic preparations in the Latham kitchen. Never yet had Leila allowed her man to go to sea unaccompanied by a special store of food and clothing, which she herself made ready with untiring zeal and a mildly aggressive eye. Always there were three boxes, which, the night before, were ranged in mathematical precision upon the kitchen floor, to be filled and sealed in the small hours and taken aboard by the steward at the last hectic minute. The smallest box contained medicines: something for a cough, and something for dyspepsia and something tried and true for earache and flea-bite and scurvy—although, in justice to the captain be it said, his ruggedness, his Bessemer-steel digestive apparatus was the talk of every ship he sailed. The second, a somewhat larger box, carried clothes; and of these we need note, as representative, only woolen underwear the color of a ripe tomato and twenty pairs of extra-heavy knitted socks. The third, largest and stoutest of all, always held food. And it was here that Henry Latham's wife evinced her greatness. Throughout the country-side, a remark was current that "Leila Latham cans every durned thing that 's fit to eat." Actually she did that. Soups, meats, pie-fillings, vegetables—all these, besides the ordinary preserves, of which there were always a dozen pint jars bearing the label "Grape and Hickory Conserve," the captain's favorite, she packed neatly between heavily padded layers of newspapers. Small wonder the steward never complained at the heft and unwieldiness of that third and massive box!

Into these preparations the good woman now plunged with a kind of delighted

militancy, with a wildly calculating eye. From the kitchen doorway—no inch nearer—the captain stood happily, his pipe in his mouth, and told her, as usual, that he'd never know what to do with all that trash. And upstairs, in the attic bedroom, forgotten in the hustle and bustle of impending departure, Sam sat—and waited.

He had made his own modest preparations, which consisted chiefly in putting on most

Slowly, mournfully, the ormolu clock on the sitting-room mantel struck two. For an hour the house had been quiet. From the bedroom below him Sam could hear his father's contented snores. His shoes in his hand, he stood up and blew out the little lamp, stole across the room, crept down the attic stairs.

He knew the way well. But now and then the ominous crack of a warped board made



"SHE STOPPED AND STARED AT HIM. 'SAM! FOR THE LAND'S SALES!'"

of the heavy clothing he owned. He had written a letter to "Mr. Lemuel P. Dodge," saying that it would be "impossible" for the undersigned to continue as store clerk, and would Mr. Dodge accept the current month's salary as part recompense for so abrupt a departure. He had written another, a shorter letter, to his mother, the contents of which are not for prying eyes and will never be known. And he had taken sort of good-bye of "Perry on Lake Erie," a monstrous colored lithograph tacked over the wash-stand, thumbed a tattered copy of "The Pilot" for the last time, and looked about the familiar beams and age-worn rafters with a curious feeling in the pit of his stomach. So Sam sat on the edge of his black iron cot-bed—and waited.

If they would only hurry, down there. He was ready.

him pause, his heart leaping in his throat like a scared rabbit. But the old house gave back no echo; its ghostly silence seemed a sign of disdain.

Slanting through the kitchen windows, a pale last-quarter moon shone on the stove, the pantry table, and those three boxes standing in a row. Sam stopped and laid his hands lightly on the boxes. The thought came to him that some day he would be going off to sea, just as his father was doing to-morrow; that perhaps some day some woman would make great and loving preparations for his venture, with the loyal care, the never-ceasing forethought that—But no. "Some day," perhaps, was well enough; but no woman on earth could do the things his mother did in just the same incomparable way. No woman on earth or yet to come—not one!



He brushed a hand across his eyes and turned to go. And as he turned he saw a square of light come dancing on the wall, heard the regular creaking of approaching footsteps down the hallway.

She had a wrapper over her flannel nightgown, and her thin gray hair was up in papers. Her hand shaded the lamp from the draught and cast its brilliance up like footlights into her homely, kindly face. A pair of thick gray woolen socks hung over her shoulder—mute testimony of a last wakeful thought. She stopped and stared at him.

"Sam! For the land's sakes!"

"Sh-sh, Mother!" he said, and laid a timid hand on her arm. "There's a letter up in my room, tells you all about it. I've got to go. It's not just that I want to—I've got to!"

"Got to?" she repeated wonderingly.

"The letter 'll tell you. Don't you see?"

She was the wife, the daughter, the granddaughter—of seamen. There came into her face a look of understanding. She reached up suddenly to pat his shoulder and kissed the center of his forehead.

"You go ahead, Sam," she whispered. "I won't tell." Then she snatched the socks off her shoulder and pressed them on him stupidly. "Here. Take these. You'll need 'em, I reckon."

He gave her a great bear-hug, so that the lamp wavered and rocked. He said, "*Mother, you're the goods!*" and kissed her cheek. The back door closed behind him. Then it opened and his head appeared. "I'll be back—with my third-mate's papers—you know that, don't you?"

"Yes, yes, go along," she answered. The tears were blinding her. But she smiled proudly at him as he looked in at her. Then he shut the door.

The gate clicked. Who of us dares stay to watch a woman tremulously praying for the welfare of her men folk?

THAT pale last-quarter October moon was a red-hot sliver in the west as Sam Latham felt his way haltingly over the tumbled oddments of the waterfront. He kept one hand touching the warehouse and crept along the pier. Ahead, he could just see the new-hewn spars of the *Etta Deering* pointing at the starlit sky; they glistened faintly even in that gloom. And a riding-light slung to her forestay swayed gently in the cool night wind. Except for a vague lapping, the whole wharf was still. "All hands' shore leave the night before," thought Sam.

He stepped upon the cap-log, swung himself over the rail, and landed noiselessly on deck. A thrill stole up his spine as his feet touched those sound teak plankings. But he allowed himself no sentimentalizing. There should be a watchman about here somewhere. At any moment he might pop out around the corner of the warehouse.

And discovery meant failure. For his father would not dream of believing the only story he could tell—the truth. His father would think it was a subterfuge, a pretense for the gaining of that great desire.

Directly ahead of him yawned the fore hatch, its cover slid part way over the coaming ready to be closed and battened in the morning. He scrambled over the edge and felt about with his feet until one touched the top rung of the ladder. And in that instant, as he stood there hesitant, came the sound of muffled voices on the pier. The watchman—not a minute to lose! Swiftly Sam descended into the cavernous depths of the *Etta Deering*.

Down he went, seemingly for miles, into the utter blackness—seemingly, until he should be standing on the harbor bottom. And finally his lowered foot, questing yet another rung, met instead the firm crunch of beach sand. Good old Tamaquid Beach! How often he had played along its level reaches! He stopped for a last look upward.

Far above his head there hung a thin rectangle of blue-blackness just a shade less Stygian than the inky gloom that pressed in all around him. That was the partly open hatch, he thought. And it cheered him to see two or three tiny stars up there, framed in that tiny diagram and twinkling and blinking as if this bleak, shadowy horror were all a dream, to be lived through stanchly so that better things might come. But he shivered; it was pretty cold.

Sam turned from the ladder and, dropping to his hands and knees, crawled forward along the sandy bottom of the *Etta's* forehold. He had this planned. He knew exactly where he wanted to go, what he wanted to do. But he went cautiously, not to butt his head against the stanchions. It was almost unearthly, this slow creeping into black nothing!

Now, the bulkhead which frames off the forward end of the forehold is usually a partition which separates this cargo space from the crew's quarters in the forecabin. And it has a door, invariably kept bolted on the forecabin side—to keep out rats and

spooks. But it is a thin partition, and it runs downward only to the level of the fore-castle flooring; the shelving space under that flooring, and thus between it and the ship's stem, being used for additional ballast.

Years of eager wanderings through ship-yards and their gaunt, cradled skeletons had taught Sam these and many other things. And he found everything exactly as he had expected.

His raised arm touched the bulkhead. He felt along it downward until he reached the point at which its lower edge touched the sand. Then his fingers dug in and under, and found the fore-castle flooring-boards meeting the bulkhead in a right angle. And underneath the flooring, just as he knew there would be, lay more tight-packed sand.

With one hand continually touching the bulkhead, to guide him, Sam now crept along it until he reached the vessel's oak timbers on the starboard side. Then he crawled right back again to port, counting his steps—fifty-six. For half that number he retraced his way and stopped, facing the bulkhead. He should be now directly over the *Etta's* keel. Dead ahead of him, through that partition, lay the center of her fore-castle, and on that center line, backed up against the partition, stood the stove. He began to dig.

In twenty minutes' time he had a burrow scooped that would accommodate the six-foot length of him, leaving only his head out

in the forehold. In he went, feet first; and chuckled mildly to himself as he felt the grateful warmth of the dry sand and the coal stove overhead. He began to feel marvelously sleepy—which, after all, is hardly to be wondered at. This cubbyhole was as warm and dry as the black iron cot-bed at home—and at least no harder!

Sam's tired head went down on his crossed arms. Like a woodchuck in its hole, he lay with only his head in the air. In the massive, impenetrable blackness ahead and around and above him, his brain began to picture images of light dancing on a cave wall. Gradually the awful immensity of those surroundings dwindled and diminished in importance. Slowly there came a sort of comfortable music to his ear. It sure was good—to be aboard at last. Going somewhere this time—Mr. Waite's office—that was the thing—Mr. Waite—Dad—third-mate's papers—clipper-ship—maybe some day when—

Like a knife came sharp, whispered words. Sam shot awake with a great start; then held himself motionless, his eyeballs smarting as they strove to pierce the gloom. The voice had ceased. But the wooden walls of that majestic chamber were still murmuring its echo. The voice had been harsh, with a dry, metallic twang; and it had lisped absurdly.

"Finley," it had whispered, "ain't snaggin' much from this ol' forehold!"

(To be concluded)

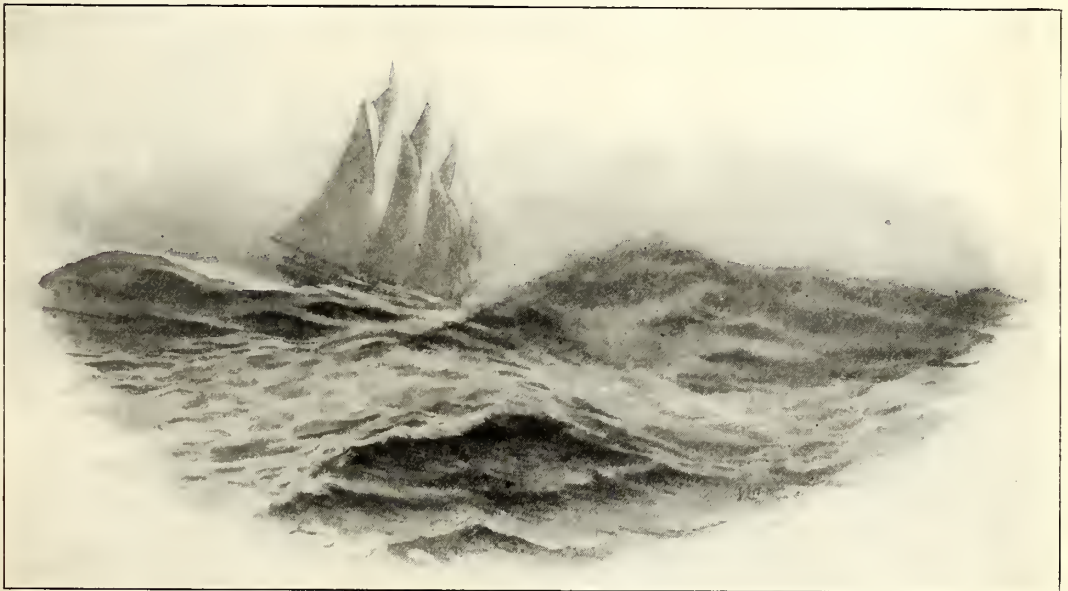



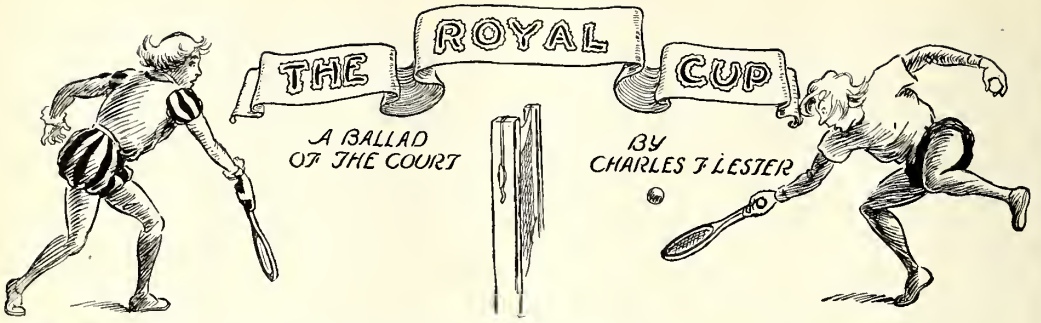

WITH eager haste, two rackets, and a massive pop-corn ball, Sir Harold neared the royal park and lightly scaled the wall; His mouth was filled with pop-corn and his soul with purpose high; Quoth he (though somewhat thickly), "I 'll win this match or die!"



The royal tennis tournament (I meant to mention that) Was going on (or coming off), and Harold's trusty bat Throughout the week had proved so strong that now, as runner-up, He was running down to-day to play Count Cutup for the cup.



Sir Harold's game was speedy, though he had too long a head To play a head-long game when softer shots would do instead. "Although," quoth he, "at bottom, I prefer to play with top, Still, when there is a lot at stake, I sometimes use a chop."

Sir Wibble and Sir Wobble lost their first-round match, alack! When Sir Wibble's railroad service caromed off Sir Wobble's back. Lady Kate and Baron Flubbit were another losing pair; Their doubles were so *very mixed* they gave up in despair.



The sun, a glorious, gleaming globe, glowed golden overhead; The grounds were all in readiness, the linesmen all in red; The king was sitting near the court (a very fitting thing), And, as you might suppose, the court was sitting near the king.



Count Kazink



The match had drawn a host of noble knights and ladies fair  
(In fact, I've drawn a few myself)—'most every one was there,  
(Excepting old Sir Grumpus, who was overheard to say  
That he could n't stand a racket—and so he stayed away).

The umpire was the Count Kazink—a clever man, though queer;  
He resided near a mountain (though not a mountaineer).  
His palace had ten stories, and the tower was—but wait!  
That's quite another story, so I won't elaborate.



Sir Grumpus

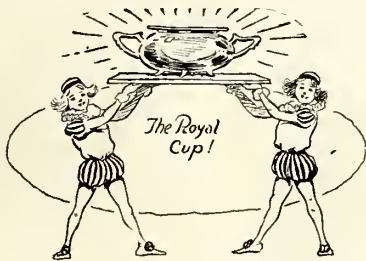

The royal band stopped playing (at which the king woke up);  
Two pages (duodecimo size) brought forth the royal cup;  
The gallery took a deep-drawn breath, the players took their place,  
Count Cutup swung his racket—and shot across an ace!

I can't go into detail—'t was a battle of the strong;  
(They had a single rally eleven minutes long!)  
But Count Cutup lost on errors in the ninety-second game,  
And I greatly fear his feelings coincided with his name.

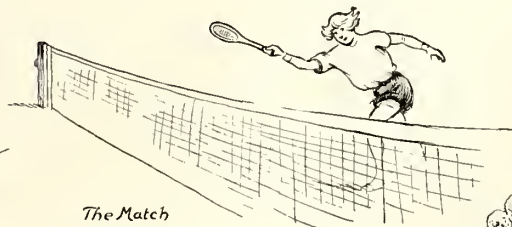
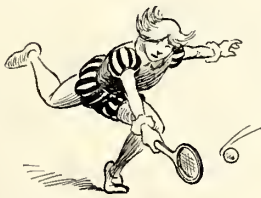

The Match

And so Sir Harold won the cup—and so my story's done.  
No doubt you're glad on both accounts (I'm sure you are on one!)  
And should you seek a moral, here's what I would suggest:—  
Be sure to train on pop-corn—and you'll always play your best!





# THAT CLASS ELECTION

By A. MAY HOLADAY

It was during a temporary lull in undergraduate affairs, following close upon a frantic period of fraternity "rushing" and those first nerve-tearing "ex-es," that the death-blow was given to at least one of the vague but awe-inspiring Stanford traditions.

No one seemed to know when or by whom the insurrection was incited, but, like the proverbial snowball, it kept adding unto itself until, on election day, it involved the Row, Roble Hall, Encina, Sequoia, and the entire student body.

It was on a Saturday evening preceding the election that the clan had gathered in Mervyn Kane's room, invariably chosen by the resident sophs of Encina Hall for the discussion of weighty matters—such as the coming sophomore election—because of its isolation at the extreme end of the corridor.

They were all there—"Pepper" Grein, red-headed and fiery of temper, "Tubby" Wells, his exact opposite, Elmer Lucas, known to the Hall as "Luke," "Shorty" Bishop, Douglas McNear, and several others, including a sentinel posted at the door to guard against a possible surprise-attack from the heel-crushed frosh.

"Fellows," Pepper began the discussion, "you know we have always stuck together, and we've got to do it now! Heretofore, our class elections have been a slate—some high-brow, backed by the powers-that-be, is slated for class president, and class president he becomes. You all know the frat that pulls off this little stunt. With them, it's a case of 'fraternity first and Stanford afterward.' The faculty opposes it—but what has ever been done about it? Fellows, it's up to us to do something right now! We'll be trampling all over Stanford tradition, but—"

"Tradition be hanged!" exploded Tubby, from his place in the only comfortable chair in the room. "There's too blamed many of 'em, anyway. We could spare one or two."

"Right you are, Tub!" cried Doug, whose views were as sincere as his freckles. "In the democratic atmosphere of Stanford, how comes it the frats have the monopoly in student-body elections? Look how we outnumber them in Encina—six to one!"

"Numbers don't count unless we stick together, you know!"

"You've only got to watch the Hall

fellows follow the band when the bunch comes over from the Row to begin wire-pulling," scoffed the indignant Luke.

"Why, lots of chaps don't even bother to vote. They say there is n't any use when the thing is all cut and dried beforehand."

"Dishi Psi picked a lemon for us this time—a chronic queener," continued Pepper. "Marsh is a lounge lizard, a ladies' man, and nothing more. Do we want him?"

Cries of "No!" and "I'll say we don't!" came from every side.

Tubby eased himself back lazily and elevated his feet to the study table. "What say we put up a rival candidate from the Hall—one who will represent the entire sophomore class, not be a mere mouthpiece for a few royal highnesses over on the Row?"

"How about your naming some one?" a voice rose flippantly from the circle sprawling comfortably on floor cushions.

"Suits me! I'll say Dexter MacDonald," drawled Tubby.

The silence seemed almost thick enough to cut. Then the room hummed with hoarse, derisive shouts.

"How'd he get that way?"

"Give him the air!"

"Ouch! Hits me like a wet sock!" some one groaned.

"Key down!" the sentinel hissed wildly. "You'll have the rest of the Hall rushing us in a body."

"Hey, fellows!" Pepper was vainly attempting to make himself heard above the din. "You know we all like Dex. He's a peach of a chap every way, but—well, you know, 'hashing' is n't exactly the job for a soph president, so he would n't stand a ghost of a show."

"Seems to me it would be a pretty raw deal to put over on old Dex," mused Merv Kane. "He'd have about as much chance as a sneeze in a hurricane, and it would hurt him to lose like that."

"Lose, did you say? The dark horse always *wins* if the thing is managed properly," Tubby offered with a careless wave of the hand.

"Hear! Hear! Wells!"

"Campaign Manager! Oh, you Wells!"

"Speech!"

Amid the bedlam, Tubby Wells rose heav-

ily to his feet, a flush of determination coloring his round, good-natured face.

"You fellows seem to think I can't put this thing over, so I'll just take you on! I've got a rippin' idea, and all I ask is that you keep clear out of it—see? No eleventh-hour interference goes! And you fellows stick—every mother's son of you—unless you want that lizzy, Marsh, for class president. We'll sure hand Stanford tradition a needed wallop."

But after seriously considering the matter as he strolled down the palm-lined avenue, Tubby was not so sure, after all, that his plan would work. Being a "seasoned politician" of two years' standing, he was quite familiar with the devious ways of "politics" that had featured previous class elections. The opposition boasted fraternity and sorority Row, and Roble Hall, where lived the girls who were outside the sorority houses.

The sexes at Stanford being in the ratio of three quarters of one and one quarter of the other showed the feminine element weak in numbers, but Tubby dared not underestimate their influence. He must seriously consider the girls in his campaign plans. He was decidedly not a ladies' man, and now he shook his head doubtfully as he made his way toward the dining-room of the Union—the campus restaurant—and wished he had kept out of the whole affair. It was such a bother, and there were so many things he had planned to do at this time.

Seated at a table, he beckoned to his favorite waiter—and classmate, Dexter MacDonald.

"Bring me a good meal, Dex. You know what I like. And, say! Meet me outside afterward—want to see you on business."

"All right," Dexter promised; "but I have three pages of French to do this evening."



"ALWAYS WITH A BOX OF CO-ED CHOCOLATES TO PASS OUT TO THE GIRLS"  
(SEE NEXT PAGE)

Tubby's eyes followed Dexter as he hurried toward the kitchen. No one could help liking Dex. He was such a clean-cut, honest, genuine sort of chap, with ambition enough for half a dozen. As class president he would sure make things hum.

Tubby knew, with Dexter MacDonald



money was never any too plentiful, but during this sophomore year it was scarcer than ever. His mother's severe illness had rapidly eaten into their little savings account, so Dexter had determined to take care of himself by waiting on table, or "hashing," at the Union, that catered to campus students and bachelor profs. At first it must have been a bit humiliating, yet no one would have guessed it from the smile with which the boy greeted his friends and the eagerness with which he served them.

Tubby Wells, as well as the rest of Dexter's friends in the Hall, knew that he was striving for honor points and a scholarship. How he could manage it, with more than three hours a day spent in waiting on table, they could not understand; and it made them feel a bit ashamed that their own unrestricted hours were not productive of better results. Dexter had even given up "queening" on Friday and Saturday nights, and the boys knew that he had neither the time nor the money for "stepping out."

As soon as he had eaten everything down to the table-cloth and silver, Tubby left the dining-room; and shortly afterward, the two friends met outside the restaurant. As they walked together toward their rooms in Encina, Tubby put up the proposition to Dexter that he run for the presidency of the sophs; and, a bit to his chagrin, the proposition was accepted.

"Of course, I won't have time to get out and campaign any," Dexter explained, "but you must have something up your sleeve. What 's the big idea?" He threw his arm affectionately across the broad shoulders and accommodated his long stride to the fat boy's pace.

"If I told you, then you 'd know as much as I do."

"Won't even tell your old side-kick, eh? Must be a dark secret. Now look here, Tub, no rough stuff! Understand?"

"Positively, it 's on the square! All 's fair in love and politics, you know. But honest, Dex, you 've got the other fellow beat to a batter *if* just *one* thing—oh, it 's *got* to come, that 's all! I 'll go after it right to-morrow."

And go after it he did, in various ways; while he paid for his unusual activity in blistered heels, swollen feet, and a body so fatigued that every move spelled torture. He had more dates than the calendar; over at the library, at the gym, at the post-office, where chattering groups congregated, at Roble Hall—always with a box of Co-ed

chocolates to pass out to the girls as he talked.

All this was merely by way of scouting and publicity for his candidate. Tubby had already posted Dexter MacDonald's name along with that of the Dishy Psi candidate, Willard Marsh—an act that had set the whole campus to buzzing.

But Tubby's main hope lay within the ranks of the dignified upper classmen. Not that any of them could vote, but he needed six of them to carry out the purpose he had in mind. Excitement is as nectar to the college student, and at Stanford, when any plan was on foot that promised fireworks, class distinctions were for the moment forgotten, and fresh, soph, junior, and senior hobnobbed democratically together. Knowing this, Tubby dared hope.

But it was not until the very day preceding the election that he called into secret conference the six upper classmen, carefully chosen from Encina's and Sequoia's ranks for their social status and their wide influence in student affairs.

At first, the group greeted the plan with howls of derision; then they began to see the other side; and ended by agreeing to lend a hand in showing up—in its true light—this practice of class elections being dominated by a small, select group—the Dishy Psis.

Tubby Wells heaved a sigh of relief. "Then you fellows are with us?"

"To a man!" came in an emphatic chorus.

"Fine! We 'll meet at the southeast corner of the Quad to-night at 7:30. Be sure to dress in your gladdest rags. So long, fellows!"

ALWAYS on the evening preceding a class election it had been the custom of the exclusive Dishy Psi fraternity to assemble its members for a final confab, inviting as guests an equal number of girls chosen from among the most popular and influential co-eds on the campus.

Of course, the Dishy Psis were not attempting to influence the feminine vote! Unthinkable! Their modesty along that line was well known. Just a delightful evening's entertainment, with plenty of "Stanford tradition" sandwiched in—that was all. But it had always proved sufficient to line up the feminine voters in the way they should go. Thus did history repeat itself year after year.

On this particular occasion, the banquet-room was given over to the sophomore members of the Dishy Psi, in view of the particular interest that centered around the sophomore

class election on the following day. The banquet tables were sparkling with silver and cut glass. The center of each long table was adorned with baskets of fruit and flowers, with occasionally a fraternity emblem en-

On the stroke of eight the places were all filled, and soon the banquet committee began to squirm. *Where* were the waiters? They had all been on hand in the kitchen not fifteen minutes before! The committee began to scent trouble. But just as their patience was wearing a bit thin, the doors were flung open, revealing six dignified upper classmen in immaculate dress-suits, each fellow carrying a tray.

The Dishy Psi sophs were too dumfounded and wrathful at this assumption of authority to notice that Dexter MacDonald, the rival candidate for the sophomore election, had assumed the rôle of head-waiter—but not a girl missed it! How well the dress-suit became the straight, boyish figure! And why had they never noticed him before?

Inwardly, Dexter was filled with a panicky fear for the fate of the kidnapped waiters, as well as for the success of Tubby's plan—revealed to him only a few minutes before as he was being rushed frantically into the borrowed dress-suit. Outwardly he seemed calm, and intent only upon directing the improvised waiters, who needed quite a bit of coaching.

While not a word was spoken, the significance of the thing straightway began to penetrate.

There was Wilbur Dean, son of the San Diego oil king, Sidney Walburn, whose father had made a fortune in lumber, Elbert Lane, son of a state senator, Bernard Van Loan, editor of the college daily; James Carrington and Edwin Lee—all hashing at a banquet at three dollars each! And if fellows like Van Loan and Dean were not

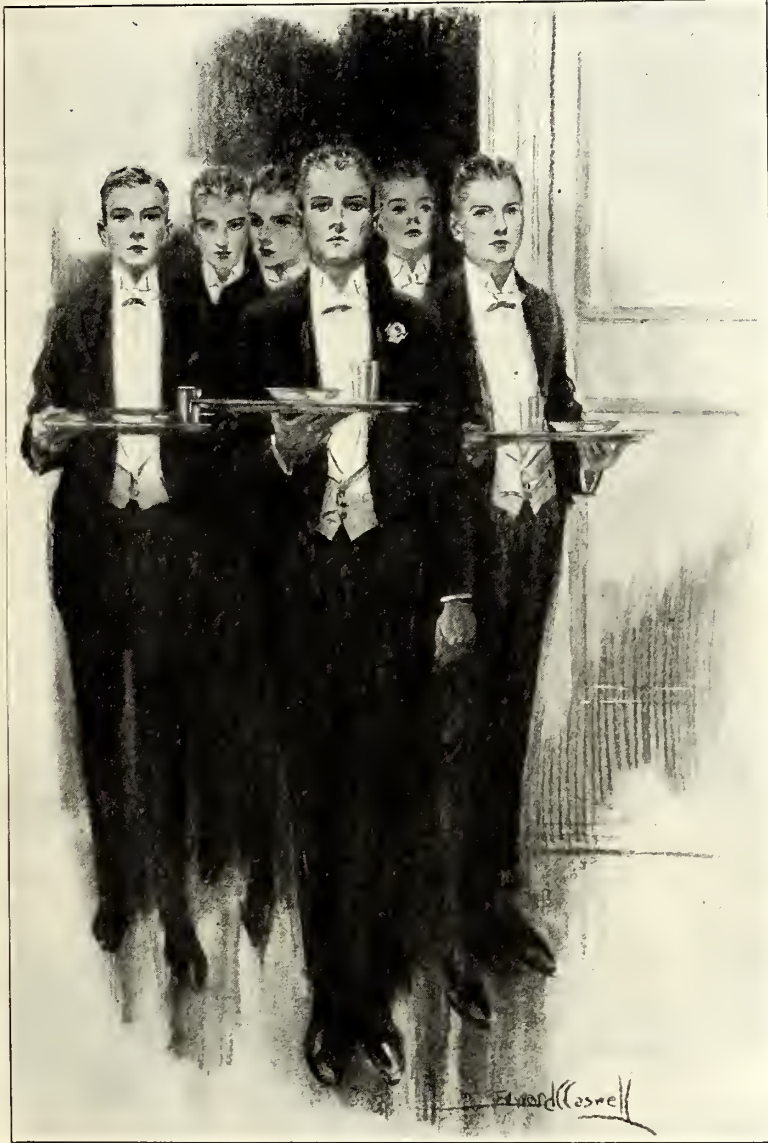

"SIX DIGNIFIED UPPER CLASSMEN, EACH CARRYING A TRAY"

twined with a big red "S." The Dishy Psis had eclipsed all former efforts and now proudly led the fair guests to their allotted places.

The chef from the Union had been engaged for the great occasion, and half a dozen student waiters arranged for—among them, Dexter MacDonald.



above hashing—the lesson in democracy was driven home in no uncertain way.

Dark looks were cast toward the waiters by the Dishy Psis who dared not openly protest against the dictates of their betters, the upper classmen, though they vowed vengeance at no distant date. The girls seemed curiously interested in the waiters, and not greatly impressed by the magnificence of the banquet; while their hosts began to wilt visibly as they felt their usual influence slipping, until it finally came to them that Dexter MacDonald was just the same as elected before a vote was cast.

At breakfast next morning an account of the affair leaked out, and the entire campus rocked with mirth. The sophomore election that day resulted in a land-slide, as usual, but a land-slide in favor of the Hall candidate—Dexter MacDonald. And in the evening he found himself the center of a cheering group that had gathered on the Quad steps.

“Speech! Speech!” Every voice took up the shout, while the glow of recent victory and *real* Stanford spirit pulsed warmly through their veins.

The newly elected class president could hardly realize, even now, how it had all come about. His heart thumped loudly against his ribs.

“Fellows,” he began, “I—hardly know how to tell you what this honor means to me. But it also signifies something to Stanford. Our victory shows that dictatorial methods will no longer be tolerated in a democratic institution like this. We have—er—presumed to—”

“—hand a certain so-called ‘Stanford tradition’ a wallop that will keep it out of the running for some time to come!” finished a voice from the crowd.

And, judging by the deafening cheers that rose up from the Quad, there were few who mourned its untimely passing.

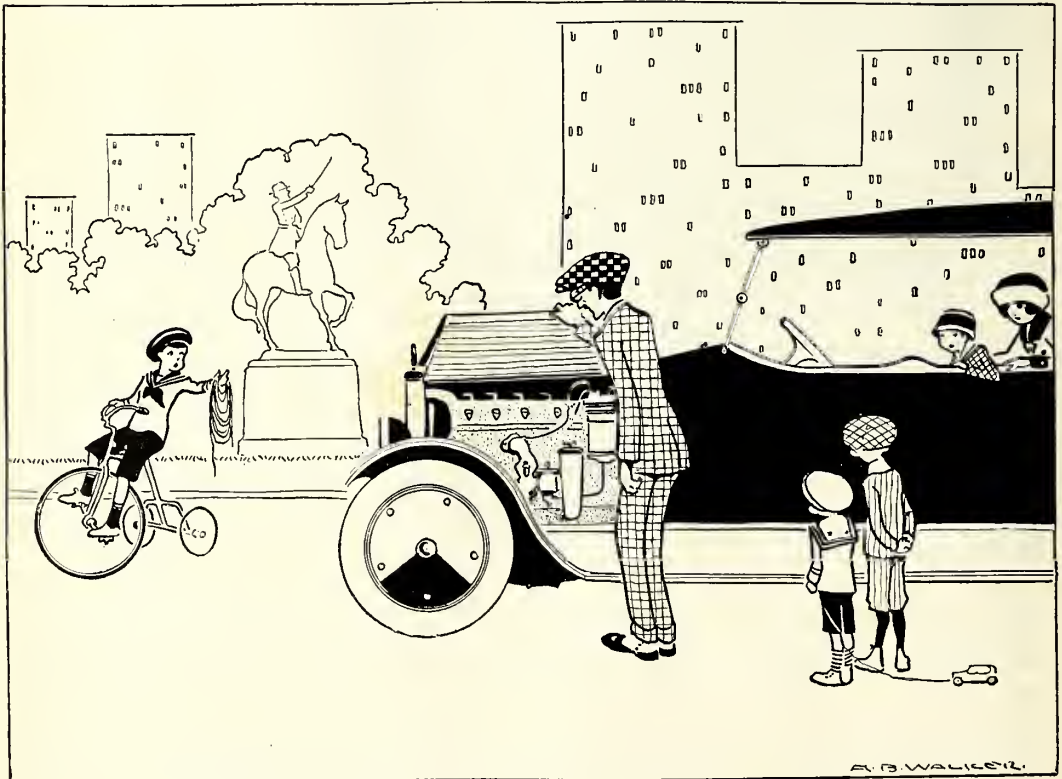

BOY: "I BEG PARDON, SIR, BUT MAY I GIVE YOU A TOW?"



by  
Arthur Guiterman



THE little Armadillo  
Across the southern billow  
Is much too stiff  
For comfort, if  
You take him for a pillow.



The independent Camel  
Objects to any trammel;  
And some there are  
Who think him far  
Too bumpelty a mammal.



The baby Kangeroodle,  
That small Australian noodle,  
Just hops and hops  
And never stops!—  
I'd rather have a Poodle.



# A MEMORY CHAIN

By RUTH H. WITHINGTON

A MEMORY chain! What? Never heard of one? It is one of the most interesting ways in which to remember your trip into foreign lands. One can always find little silver trinkets that suggest the place, or something that happened during one's visit.

We took the Mediterranean trip—fifteen days on the ocean—and then did Italy thoroughly. When we touched at Gibraltar we took the usual drive in one of the fascinating donkey-carts to see the wonderful fortifications of which the British obtained control in 1704. When we reached the line dividing English and Spanish territory we got out of the donkey-cart and walked around. It was market-day, and there were so many queer-looking people all in their native costumes that I am sure every nation was represented.

It seemed to me all were either riding or leading a donkey heavily laden. And that gave me the idea—I must have a little donkey to remember the day. Looking around the shops, I found just what I wanted—a little silver donkey; not an inch long, which I purchased for two francs.

Two days after, we stopped at Algiers and we spent most of the morning wandering around the Arab quarters, through the narrow streets where we would suddenly come upon an Arab leading a camel—that, I knew, would be the next purchase for my chain, and it was.

The next day we landed at Naples. Being carnival day, which they have once a year, I had no difficulty in finding a little silver man dressed as a fool.

We took the night boat to Palermo, Sicily. The emblem of the Island is to be seen on everything; so, after I had bought one of the funny little heads with three legs,—which is also supposed to be the shape of Sicily, each foot representing a cape,—I looked around for something appropriate for Palermo. I did not have to look far, for I found a dear little copy of their wonderful carts; only, of course, it had to be of silver, and it did not show the way in which they paint them, with either religious, or historical scenes.

In Taormina, a little town perched high up on the side of a mountain, like an eagle's nest, it was very easy to find just the right

thing, for on the top of the funny old fountain in the Piazza, from which all the water is carried into the homes by the natives, there is a figure with the head of a woman and the body of a horse.

At Capri, an island just off the coast of Naples which used to be called Goat Island, I found a dear little silver goat-bell, but only after a hunt of several days.

Going back to the mainland, we stopped at Sorrento, seeing for the first time the dance called the tarantella, one of the most graceful I have ever seen.

Looking for something that would remind me of it, I found a little silver maiden dressed in the tarantella costume.

We took the wonderful drive from Sorrento to La Cava, stopping at Amalfi a few days—such a quaint little town, filled mostly with fisher people. You find for sale old coins, which they assure you they have dug up in the neighborhood. I have one on which is the head of St. Peter.

At La Cava I found a little silver "Evil hand," which all through Italy you hear so much about. They say if you point your fingers in this way you can be imprisoned for doing so, as it is equivalent to saying that the person has the "evil eye."

We spent the next day in Pompeii, where they have many little things made of the lava. I bought a very tiny little pitcher for my chain.

I hardly have to tell you what I chose for Rome, since we are all familiar with the story of the wolf and Romulus and Remus.

Siena, is a town made up of *contrados*, or districts, as we would call them over here. We lived in the *contrado* of St. Catherine, the emblem of which is the goose with the crown on his head.

At Pisa I found a little silver tower, just like the wonderful leaning tower.

Florence has more things to choose from than any other place. I took the little Della Robbia baby, which was so like the original on the outside of the Foundling Hospital.

At Venice I bought the beads of which I made my chain; and I enjoyed arranging the silver trinkets as much as buying them. I added a dear little gondola for Venice.

When I found a little silver model of the Milan Cathedral I was delighted, for to me that cathedral is the finest in Italy.

Then, on the Italian lakes all the peasants wear the wooden shoes in which they clatter, clatter along on the cobblestones. I bought

the smallest wooden pair I could find, about an inch long.

Finally, coming home, the purser on the ship had some little silver fish, jointed so they wiggle, which I thought was a good ending to my chain.

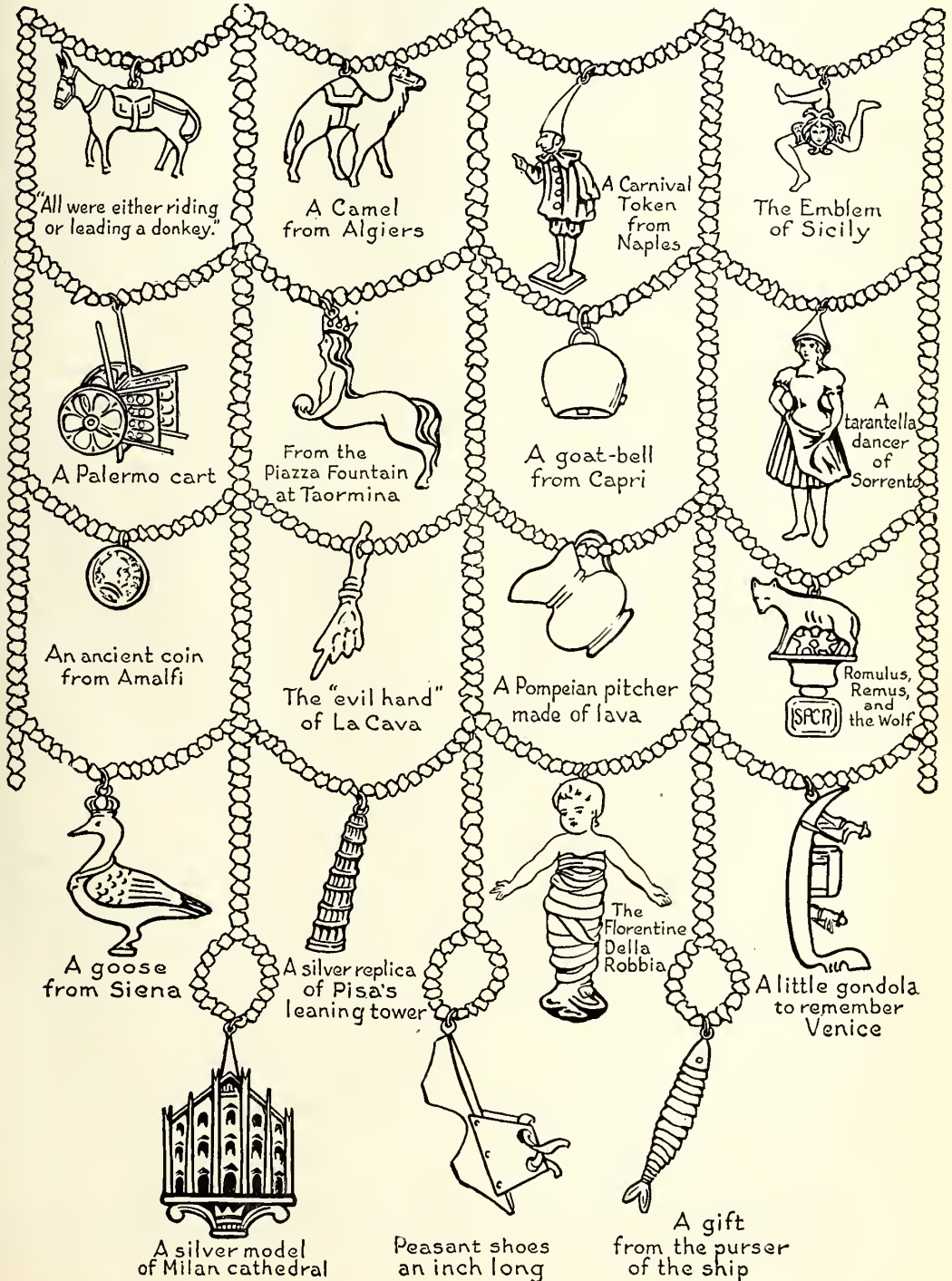

"All were either riding or leading a donkey."

A Camel from Algiers

A Carnival Token from Naples

The Emblem of Sicily

A Palermo cart

From the Piazza Fountain at Taormina

A goat-bell from Capri

A tarantella dancer of Sorrento

An ancient coin from Amalfi

The "evil hand" of La Cava

A Pompeian pitcher made of lava

Romulus, Remus, and the Wolf

A goose from Siena

A silver replica of Pisa's leaning tower

The Florentine Della Robbia

A little gondola to remember Venice

A silver model of Milan cathedral

Peasant shoes an inch long

A gift from the purser of the ship



# SUCCESS AND FAILURE

By HILDEGARDE HAWTHORNE

NOTHING, of course, could be easier than to tell the difference between success and failure. Nothing simpler than to pick out, among the persons known to us, those who have succeeded or who are succeeding, and those who are failures.

Maybe. But, come to think of it, maybe not!

First of all, try to answer clearly what you mean by success. Do you mean that success is something you get, or something you are? If it is something you get, then it is not hard to recognize. A man who has got a lot of big shining things is successful; a man who has nothing much to show to the world is not.

But this way of settling the matter is not entirely satisfactory. There is so much more to each of us than just that part that likes to own things, likes to make a show in other men's eyes. There are even plenty of people who don't really care to own much of anything at all, and who are not interested in the very least in having the eye of the world turned upon them in envy and admiration. To be loaded with splendid possessions and to be put into the head-lines whenever they did anything would be, from their point of view, absurd and a bore, therefore a failure. To call that sort of life success would appear, to such men and women, merely ridiculous. So that right at the start we run up against the fact that success is not a definite thing, to be labeled and recognized by its appearance, like a golden crown or a red rose. On the contrary, it looks exactly like failure to one person, beautiful or ugly, desirable or hateful to others, according as what the opinion of each regarding success may be. "Look, there is success, that shining creature!" cries some one, pointing eagerly. On which his companion, in disgust and surprise, remarks, "Well, if that 's success, give me failure." And there you are.

All right. It may not be simple to label some definite thing and call it success. But how about saying that success is getting what you want, no matter what that is, no matter how it differs from what some one else may want?

But that won't do, either. For you might have wanted something which, after you

had it, would degrade and coarsen your life, would surround you with misery, break down the fiber of your soul, and turn existence into something too heavy to be borne. Such a type of success would clearly be failure, even, at the last, to whoever had achieved it and had been for long deceived by it. In the old days, when there were no books and people told each other stories that were remembered and repeated from one generation to another, there was a certain favorite tale about a man who, in exchange for wealth and power, had sold his soul to the evil one. In the end, the wicked being comes for his payment; but long before he comes, the horror of what he has done, the terror over the payment that will be due, has made the things of wealth and the exercise of power hateful to the man whose soul is paying the price. He would be glad to recall the terrible bargain, but it is too late, in the old story, and he is lost.

Such stories are picturesque ways of telling enduring truths. The story means that any one who pays away something good and precious in himself for sordid or selfish reasons is a failure, a lost creature, bound in some sort to suffer for the bargain, and bitterly to regret it. Though he gets all he bargained for at a price that seems little enough beside that gain, in the end he comes to see that the precious thing he gave away was worth everything else, that, beside its loss, no gain can stand.

So, gradually, from thinking that nothing could be easier than to designate exactly what success is and what failure is, we grow to wonder whether it is possible to indicate at all which is which. For what is success looks so often like rank failure, and what is failure sometimes glitters in men's sight like the most radiant success.

There is, however, a touchstone that helps to solve the strange puzzle.

Let us take three different men and see which of the three is the success. Each of these men is rich; each stands at the head of an important business, commanding many men under him; each has reached the goal he set for himself.

The first of these three men we will suppose to have been a trader by instinct. He loved the work he chose; big business made

to him a vital appeal. His life was in it. From his point of view and by his standards, he always did the right and honorable thing; always played fair. Success came to him, and he enjoyed it. He loved the pomp and noise of it, he was generous with his overflow, and he used all his faculties in the making and management of his fortune. He could imagine no other type of success.

The second man also wanted to be rich and to command others, to be pointed out as big and successful. He was not able to get what he wanted directly. So he schemed and defrauded as far as he safely might. He bought other men for his purposes, and he sold his good faith to the highest bidder. He got what he wanted and held it firmly, if uneasily. There were those who knew of shady actions of his who must be kept safe. There were those who had suffered through him, who might seek revenge. The ideals he had known in the early part of his life were dulled and dying. The generous instincts in him had been smothered. He was distrusted and feared, and such friends as he had he despised, for he knew it was what he had, not what he was, that attracted them.

The third man had reached his position by another road. There was in him a longing to be an artist; he was capable of dreams that were beautiful. To realize these dreams he would have had to devote his life to work which might bring him in little wealth and perhaps less fame. The work alone would have to suffice. He was not strong enough to make the sacrifice demanded, and when opportunity offered to make a lot of money, he chose to do it. Half he hoped and promised to himself that as soon as he had enough money, he would stop the empty and wearisome work he was engaged in, and go back to his dreams and create the beautiful thing which he knew he could create, once he devoted his whole time and love to it. But the time for beginning this real work of his never came. He got more and more deeply involved in his trading, he grew to depend more and more on the possession of things and on the envy and admiration of others, until he could not change. He had sold his soul to the evil one, who would not let it go—that is how the old story would have said it.

As you see, only one of the three men was a success, made a success out of himself and his life. He did well what he was fitted to do and what he loved doing. And he did well with the results he achieved. The

other two were failures, one because he became mean and cruel in achieving his ends, the other because, for money, he turned from what was finest in himself.

The last two made slaves of themselves, ceased to be free men; and he who sells his freedom is a failure, no matter how gorgeous may be his possessions.

Success has many shapes, but true success must be based on freedom. Do you remember Lovelace's lines, written from prison?

If I have freedom in my love  
And in my soul am free,  
Angels alone, that soar above,  
Enjoy such liberty;

Although Lincoln died at the hands of an assassin, and though his life was a sad one, we know that he was successful. Theodore Roosevelt also achieved success. So did Audubon, different as were his powers and his results. So, too, was Corot a great success, though through his life he made barely enough to live upon. But the life he did live was the one that most entirely and most beautifully expressed all that was finest in him, and he made the world a happier and finer place because of what he left it. The life of a man like John Burroughs is one of true success, yet think how simple it was in all its outward manifestations.

Success itself is neither noisy nor ostentatious, though it may come surrounded with splendor. Success means developing the best and the most interesting things in you; it means doing the work which you can do best as well as possible, with joy, and for the sake of that work, not for the sake of the reward. Success means the ability to keep your soul and spirit free, either from the tyranny of poverty or that of riches. Success is in giving something worth while to the world, rather than in getting something from it. Success, surely, lies in being rather than having. If your life is enriching your mind, your character and your heart, if you are adding to the knowledge, the honor, the beauty in this world, you are living successfully. If you are dwarfing yourself, hardening yourself, losing your better qualities, you are a failure, no matter how much pelf and power you may acquire.

There is a great deal of talk these days about "selling yourself." About the advantage of knowing how to get the highest return for what you know and what you do. Your market value is insisted upon, and you are warned of the foolishness of letting yourself and your talents go cheap. There is,



of course, good sense in much of this sort of talk. In a life of competition and the necessity of meeting your obligations and gaining the lovely and desirable things of our civilization, you do need to take thought of the market, and to see to it that you are fairly recompensed for what you do. It is your duty to get as good a price as possible, without sacrificing something else that is better. Your market value is *not* the most important thing in life, and to insist upon it above everything else is to cheapen life and to put the less essential above the best in you. Money is the measure of a great deal, but it is not the measure of the greatest. If you want success, keep money in its place, never let it become the dominant factor in life for you, never let it get the upper hand in determining what you shall or shall not do. When the price you must give for it becomes too high, let it go.

It always seems to me that those who have lost the sense of the wonderfulness of this world and of being alive upon it are failures. They have missed too much. The person to whom existence is a bore is really a complete failure, though he live in a palace and measures his dollars in peck baskets. The true financier is he who manages his life to the best advantage, puts the most into it, and gets from every day its full, free value. That sort of finance is worth studying by every one among us all.

Success and failure may look singularly like each other at times, but always they are as different as night and day. Most lives are a mixture of the two. But in wishing for success, wish for your freedom of mind and soul, for the full expression of your talents, for high service and happy wisdom. You may not make a fortune in getting these, but you will have found success.

---

## PEG FURNITURE

By CHARLES K. TAYLOR

LAST summer, when the writer, with several boys, was hiking in the back country of the Adirondacks, we came across an interesting chair in an old farm-house. This chair must have been many years old, for although it was made of oak it was well worn. Its age was not the remarkable thing, though a chair that would last long in a house so full of children must have been a marvel! The interesting thing was that no nails were used in its construction. It was put together entirely by means of pegs!

The chair in question interested the boys very much, particularly as one or two of them were strong for making things for themselves. One of them decided to construct a similar chair.

Now it so happened, that when he came to it, the boy used a few screws, simply because he could not find one board broad enough to use for seat and back, and therefore had to fasten two boards side by side, held together with braces screwed across.

Let me see if I can describe the chair the boy made. The two boards forming the back also acted as the front legs of the chair. That means, of course, that it slanted back

at quite an angle. This was a good point. It made a comfortable chair to sit back in!

When he decided how long these boards should be, from the lower front, to the top of the back, he cut two 8-inch boards that length, and with screws fastened them firmly side by side by means of a couple of cross-braces. The photograph shows them clearly. In the middle of each of these boards, and about 16 inches from the lower end, he cut two four-inch slots, horizontally. These were openings through which the tongues sticking back from the seat-boards were to go.

He then, for the sake of looks, with a narrow saw, cut the tops of those boards into a circle,—or rather, a half-circle,—which made a better-looking top for the back-piece.

Now for the seat. Two boards were spliced together again. He allowed for a fourteen-inch seat. A middle section of each board, however, was cut into a kind of tongue. These tongues fit through the two slots mentioned. Just where they came to the back surface of the back support, one-inch holes were cut through the tongues. Then, when they were placed in the slots

and pegs driven through the holes, they could not be pulled out again. The photo shows the tongues and pegs holding them.

Now for the back legs—or, rather, the back leg, as there was but one! Two more

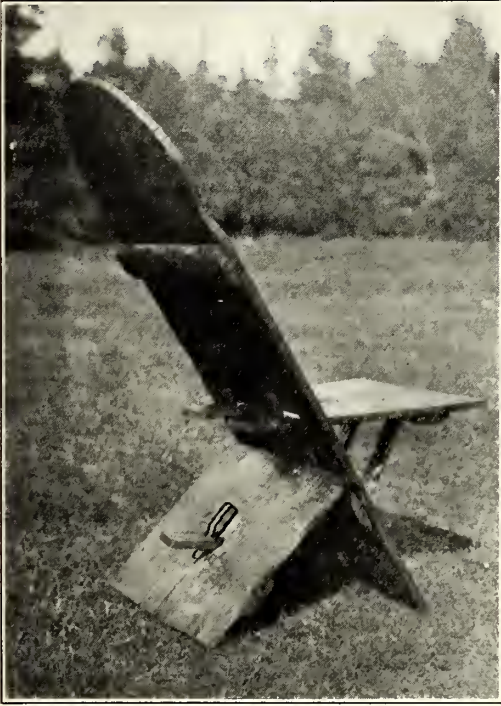

"A PEG CHAIR, STRONG ENOUGH FOR AN ELEPHANT!"

boards, again, were spliced together. Like the seat, these also had tongues which projected through slots in the back board, fastening this back leg so it could not pull away. The photograph does not show these tongues, but you can see where they *should* be, and you can take my word that they are there.

Then he cut two more slots, one in the middle of the front leg, and one in the back leg. A brace was cut that would fit from front to back between them, and tongues from this brace projected through these two slots and were held firmly with pins. The picture shows the back tongue sticking out, with its peg in place.

Now the chair would have done quite well just as it was. The seat was so tightly jammed in its slots that it would not go down below the horizontal. But the young artizan wished to make it still stronger.

He placed, therefore, two braces under the seat, running back from the front part of the seat to the slanting boards forming the front leg. These two braces had small

tongues at each end about an inch in diameter, and these were jammed into holes, in seat and back-board, just a trifle smaller.

The photograph should make the structure clear. The result was a very strong chair. An elephant could sit on it—almost!

That one job aroused his ambition. He decided to furnish his room in peg furniture, bed and all. Now you can have a lot of fun figuring how to make tables, stools, and so on, peg fashion. I will finish by suggesting how he made his bed.

He secured four corner posts about 4 inches square, those for the foot of the bed being 2 feet, and those for the head being 3 feet long. The boards making the side and end pieces were 6 inches wide and an inch thick.

Slots were cut in the corner posts, and through these were thrust tongues cut in the side boards, allowing about 3 inches to project through the other side of the posts.

In these tongues were also cut slots, instead of the usual small peg holes, and through these smaller slots were thrust tongues made at the ends of the foot and head pieces. Now if you could fix it so these foot and head pieces could not be drawn out, you would have a strong bed-frame with no nails or screws. This was accomplished by boring a half-inch hole right through the foot-board into the corner post, going about 2 inches into the latter. In this half-inch hole he hammered a carefully trimmed round pin, and the frame was made!

Did he use manufactured springs on this frame? He did not! About an inch and a half below the upper edges of the side and end boards he bored quarter-inch holes, about four inches apart. Through these he ran wire across the bed and back again, so filling in the space with a

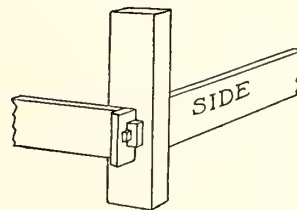

End of foot-boards showing slot

SHOWING DETAIL OF BED

network of wires, forming 4-inch squares. This wire was drawn very tightly. This made a wire bed an inch and a half below the edge of the bed. Upon this wire screen he rested a perfectly good mattress, and the bed was done. Do you catch the idea? I am sure ST. NICHOLAS would be interested in knowing of such things made by boys!



# THE INCA EMERALD

By SAMUEL SCOVILLE, JR.

*Author of "Boy Scouts in the Wilderness," "The Blue Pearl," etc.*

## SYNOPSIS OF PREVIOUS INSTALMENTS

PROFESSOR AMANDUS DITSON, the great scientist, has discovered the location of Eldorado, where for hundreds of years the Incas of Peru threw the best emeralds of their kingdom into the lake as an offering. The professor's ambition in life is to secure a living specimen of the bushmaster, the largest and most venomous of South American serpents. He calls on Big Jim Donegan, the lumber-king and gem-collector, and offers to lead a party to the lake if Jim will finance the trip, and to allow the lumber-king to have the emeralds, provided Ditson can keep the bushmaster. Jim promptly agrees to this, and Jud, the old trapper, Will, and Joe, the Indian boy, who together found the Blue Pearl for Jim Donegan, agree to go on the trip. Jud and Professor Ditson bicker as to who shall lead the expedition. A whip-scorpion decides the discussion in favor of the professor. They hear and see strange and beautiful birds in the forest, and Jud has an adventure with a black snake. They enjoy wild milk and honey, and Will studies the tropical butterflies, and at night vampire-bats break through the screen and he is badly bitten. The party travel by steamer to Manoa, the hottest city in the world. There they change to an Indian boat and travel down to Black River, which they enter by night, contrary to the Indian superstitions. Joe has a terrible experience with an anaconda, and Will is nearly swallowed by a giant catfish. They pass Treasure Rock and hear its story. Attempting to run the rapids of Black River, they are shipwrecked, and lose all of their equipment. They have an adventure by night with a jaguar, which Professor Ditson frightens away. Pinto, the Indian, makes for himself a blow-gun and the fatal urari poison; and under his direction, the party builds a new boat and starts on down the river. Pinto, Will, and Jud are treed by peccaries, Will is driven down to the ground by fire-ants, and his life saved by a sudden attack on the herd by a black jaguar. They come to the Falls of Urari, where the Slave Trail begins, which runs clear across the basin of the Amazon to the lost Lake of Eldorado. They meet a war-party of man-eating Mayas. Joe turns out to be a blood-brother of the band, and receives from the chief the safe-conduct of the skin of the sacred Yellow Snake.

## CHAPTER VIII

### THE MAN-EATERS

FIVE days later they came to a great lake which seemed to stretch away through the depths of the forest interminably, with the trail following its winding shores.

At the first sight of the water shining in the sunlight, Pinto showed signs of great uneasiness.

"This must be the Lake of the Man-eaters," he said to Professor Ditson. "I have heard the wise men of the tribe speak of it many times. All the animals around it are eaters of men. See, perhaps there be some of their tracks now!" and he pointed to where there showed in the soft sand what looked like the paw-prints of a huge cat.

"Pinto," said the professor, severely, "I'm ashamed of you! The sight of those Mayas has made your mind run on man-eaters. Don't you know a puma's tracks when you see them, and don't you know that a puma never attacks a man?"

"The perfesser 's right for once," chimed in Jud. "That 's the track of what we call a mountain-lion or panther up north, an' they don't never hurt nobody."

Pinto was still unconvinced. "Perhaps they do here," he insisted.

"You come along with me," returned Professor Ditson. "We 'll explore this lake a bit before dark." And followed by all of the party except Will and Jud, whose turn it was to make camp, he disappeared around a bend in the shore.

The two who were left behind soon found a high, sandy bank where they cleared a space and started a small fire. Just in front of them was a tiny bay, connected with the lake by a narrow channel edged by lines of waving ferns, while a little beach of white sand curved away to the water in front of the camp-site.

"Here is where Judson Adams, Esquire, takes a bath," suddenly announced the old trapper, producing a couple of cakes of tree-soap, which he had picked along the Trail, and slipping out of his clothes like an eel.

"Pinto said never to go into strange water," warned Will.

"Pooh!" said Jud. "He was talkin' about rivers where them murderin' catfish an' anacondas hide. This pool ain't ten feet across an' there 's nothin' in it except a few stray minnies"; and he pointed out to Will a little school of short, deep-bodied fish which looked something like the sunfish which the boys used to catch along the edges of Cream Hill Pond. Otherwise, no living creature showed

in the clear water, nor could be concealed along the bright, pebbly bottom.

"Better not," warned Will again. "This ain't your country, Jud. Pinto seemed to know what he was talking about. Let's wait until the professor gets back."

"Pinto will never win any Carnegie medals, an' I guess I can take a bath without gettin' permission from the perfesser," returned Jud, obstinately. "However," he went on, "just to show you that the old man never takes any chances I'll poke a stick around in this pool to drive out any devil-fish that may be hidin' here."

Nothing happened as the old man prodded the water with a long branch cut from a nearby tree, except that the motion of the stick seemed to attract more and more of the chubby fish, which he had first seen, from the outer channel into the pool.

"Gee," remarked Jud, "but those fish are tame! I'll bet if I had a hook an' line I could flick out a dozen. Better come in with me, Bill," he went on. "I promised your family that I'd see that you boys took plenty of baths an' kept your hair brushed all through this trip."

"I'll wait till the boss comes back," said Will, laughingly.

That was enough for Jud.

"I'm my own boss!" he remarked indignantly, and waded in with a cake of tree-grown soap clenched tightly in one hand. His first step took him well above his knees. There was a swirl and a flash from the center of the pool, and in an instant the whole surface was alive with a furious rush of short, deep-bodied fish towards Jud. As they approached, the old man noticed uneasily their staring, malignant eyes, and that they had projecting, gaping lower jaws, thickly set with razor-edged, triangular teeth. Suddenly the whole school were upon him, crowding into the shallow water where he stood and snapping at his bare legs like mad dogs. Before he could stir, two of them had bitten pieces of flesh out of the calves of both of his legs. As the blood from their bites touched the surface of the pool, the fish seemed to go entirely mad, snapping their fierce jaws frantically and even springing clear of the water, like trout leaping at fly. If they had not been so numerous that they jostled each other, or if Jud had not been quicker than most men twenty years younger, he would have been terribly mutilated. As it was, when he finally reached the safety of the bank, the water which he had just left boiled

and bubbled like a caldron, and two of the fish followed him so closely that they landed flapping, snapping, and squealing far up on the white sand. When Will approached them, the stranded fish tried to spring at him, clicking their jaws with impotent, savage fury.

A moment later, as he tried to hold one of them down with a stick, it drove its keen, wedge-shaped teeth clear through the hard wood. When the rest of the party came back, they found Jud and Will staring as if fascinated at the desperate, raging dwellers of the pool.

"I told you strange water not safe," said Pinto, as Professor Ditson skilfully bandaged Jud's legs with a dressing of sphagnum moss and the thick red sap of the dragon's-blood tree. "Look," and he showed Will that a joint of one of his fingers was missing. "Cannibal-fish more dangerous than anaconda or piraiba. They kill tiger and eat up alligator if it get wounded. Once," he went on, "white man ride a mule across river where these fish live. They bit mule and he threw man off into the river. When I got there an hour later only skeleton left of mule. Man's clothes lie at bottom of river but only bones inside. You wait a little. I pay them well." And he disappeared into the woods.

Professor Ditson corroborated the Indian.

"They are undoubtedly the fiercest and most dangerous fish that swim," he said. "If the water is disturbed, it arouses them, and the taste or smell of blood seems to drive them mad."

By the time Jud was patched up, Pinto came back trailing behind him a long length of liana, from either end of which oozed a white liquid. This vine he pounded between two stones and threw into the pool. A minute later the water was milky from the flowing juice, and before long was filled with floating, motionless piranhas stupefied by the poisonous sap. These Pinto fished out with a long stick, and, breaking their necks, wrapped several in balls of blue clay which he found along the shore, and, first making air-holes, set them to bake in the hot coals of the fire. When at last a smell of roast fish went up from the midst of the fire, Pinto pulled each ball out and broke the hard surface with light taps of a stick. The skin and scales came off with the clay. Opening the fish carefully, he cleaned it, leaving nothing but the savory white baked meat which tasted and looked almost exactly like black bass. Jud revenged himself by eating seven.



Toward the end of the afternoon, Professor Amandus Ditson left the rest of the party reclining in that state of comfort and satisfaction which comes after a good meal. Each day the professor devoted all of his spare time toward realizing the greatest

this king of the pit-vipers is most apt to be found. Two hundred yards away from the camp, the Trail took a turn, following the curved shore of the great lake, and in a few minutes the scientist was entirely out of sight or sound of the rest of the party. At last, finding nothing inland, he turned his steps toward the lake itself. On some bare spaces, showing between the Trail and the edge of the water, he saw more of the puma-tracks like those which Pinto had pointed out earlier in the day. Remembering the Indian's fears, the scientist smiled as he examined the fresh prints of big pads and long claws.

"Harmless as tom-cats," he muttered to himself.

A moment later something happened which upset both the professor and his theories. As he straightened up, a hundred pounds of puma landed upon him. The legend of the lake, so far as pumas were concerned, was evidently correct. Harmless to man in other places, here it seemed the great cat stalked men as they would deer. This one intended to sink the curved claws of her fore paws in the professor's shoulders, and, with her teeth at his throat, rake his body with the terrible, downward, slashing strokes of the catamount clan. Fortunately for himself, he



"'CANNIBAL-FISH MORE DANGEROUS THAN ANACONDA OR PIRAIBA'"

ambition of his life, to wit, the acquirement of one full-grown, able-bodied bushmaster. Today, armed with nothing more dangerous than a long crotched stick, he strolled along the Trail, leaving it occasionally to search every mound or hillock which showed above the flat level of the jungle, since in such places

had half-turned at the sound which her sudden spring made among the bushes. Instead of catching his throat, the panther's fanged jaws closed on the upper part of his left arm, while her fore paws gripped his shoulders, which were protected by a khaki coat and flannel shirt. Professor Ditson promptly caught



the animal's throat with his sinewy right hand and held the great beast off at arm's length, thus keeping his body beyond the range of the deadly sickle-like hind claws. For a moment the puma's luminous gooseberry green-eyes stared into his, and he could see the soft white of her underparts and the long, tawny tail which is the hall-mark of her family. As he sank his steel-strong fingers deeper into the great brute's throat, Professor Ditson abandoned all hope of life, for no unarmed man can hope to cope successfully with any of the greater carnivora.

"A dozen zoölogists have lied in print!" he murmured to himself, indignantly. Even as he spoke, he tried to wrench his left arm free. He immediately found, however, that it was impossible to pull it straight out from between the keen teeth. Sinking his fingers deeper into the puma's throat, he squeezed it suddenly with all of his strength. Involuntarily, as the wind was shut off from her lungs, the gripping jaws relaxed enough to allow the scientist to pull his arm through them for a few inches sidewise. Again the puma caught the moving arm, a few inches lower down. Again, as the man gripped her throat afresh, she relaxed her hold, and he gained an inch or so before the sharp teeth clamped tight again. Inch by inch, the professor worked the full length of his arm through the fierce jaws which in spite of the khaki sleeve and thick shirt beneath, pierced and crushed terribly the tense muscles of his arm. Throughout the struggle, the tawny beast kept up a continual grunting, choking snarl, while the man fought in utter silence. At last the whole length of the professor's left arm had been dragged through, until only his hand itself was in the mouth of the puma. Shoving it down her hot gullet, he gripped the base of her tongue so chokingly that the struggling panther was unable to close her jaws, and, for the first time during the fight, the professor was free from the pain of her piercing teeth. In a desperate struggle to release the grip which was shutting off her breath, the puma lurched over and fell full length on her back in the loosesand, dragging the man down with her, and the professor found himself with his left hand deep in her gullet, his right hand still clutching the beast's throat desperately, while his knees, with the weight of his body back of them, pressed full against her ribs on either side. As they struck the ground he sank his elbows into the armpits of the puma beneath him, spreading her front legs and pinning them down, so that her

frantic claws could only reach inward enough to rip his coat, without wounding the flesh beneath. Once on the ground, the panther struggled fiercely, pitching and bucking in an effort to release herself from the man's weight so that she could be in a position to make use of the curved scimitars with which all four of her paws were armed. The loose sand shifted and gave her no purchase. As they fought Professor Ditson felt his strength leaving him with the blood which flowed from his gashed and mangled arm. Raising himself a little, he surged down with both knees and felt a rib snap under his weight and the struggling body relax a trifle. For the first time he dared hope to do what no man had done since the cavemen contended with their foes among the beast-folk and to his surprise noted that he was beginning to take a certain grim pleasure in the combat. The fury of the fight had pierced through the veneer of education and culture, and Professor Amandus Ditson, the holder of degrees from half a dozen learned universities, battled for his life that day with a beast of the forest with all the desperation and fierce joy that any of his prehistoric forebears felt a hundred thousand years ago. It had become a question as to which would give up first—the man or the beast. Fighting off the waves of blackness which seemed to surge up and up until they threatened to close over his head, he fought desperately with gripping hands and driving knees, under which the thin ribs of the puma snapped like dry branches, until at last, with a long, convulsive shudder, the great cat stopped breathing. Even as he felt the tense body relax and become motionless under his grip, the blackness closed over his head.

There the rest of the party, alarmed by his long absence, found him an hour later. His gaunt body was stretched out on the dead panther and his right hand was sunk to the back knuckles in the long fur, while his left hand and arm were buried to the elbow in the fierce gaping mouth and his knees still pinned the panther down. Around the dead beast and the unconscious man sat four black vultures. Thrusting forward from time to time their naked, red, hooded heads they seemed about to begin their feast, when the rescuing party arrived. With his face hidden in the panther's tawny fur, Professor Ditson seemed as dead as the beast that lay beneath him. It was not until after Hen had pried his fingers away from the puma's throat and carefully drawn his gashed hand



from the beast's gullet that his eyes flickered open and his gaunt chest strained with a long, labored breath.

"I was wrong," were his first words. "The *felis concolor* does occasionally attack man. I'll make a note of it," he went on weakly, "in the next edition of my zoölogy."

"I was wrong, too," burst out Jud, pressing close up to the exhausted scientist and clasping his uninjured hand in both of his. "I thought you were nothin' but a perfesser, but I want to say right here an' now that you're a man."

The danger, however, was not yet over. The scratches and bites of a panther or a jaguar, like those of a lion and tiger, almost invariably cause death from blood-poisoning if not immediately treated. Under Professor Ditson's half-whispered directions, they stripped off his clothes, washed away the blood and dirt with clear water, and then, using the little surgical kit which he always wore at his belt, injected a solution of iodine into every scratch and tooth-mark.

"It is necessary," said the scientist, gritting his teeth as the stinging liquid smarted and burned like fire, "but I do not believe that life itself is worth so much suffering."

The rest of the party, however, did not agree with this perhaps hasty opinion, and persisted in their treatment until every puncture was properly sterilized. Then, bandaged with great handfuls of cool sphagnum moss and attended by the faithful Hen Pine, the professor slept the clock around. While he was asleep, Will and Pinto slipped away together to see if they could not bring back a plump curassow from which to make broth for him when he finally woke up; while Jud and Joe, with similar intentions, scoured the jungle for the best-flavored fruits they might find.

Will and his companion found the birds scarce. Following the Indian, Will slipped through the jungle like a shadow. As they penetrated deeper into the jungle they were careful to walk so that their shadow fell directly behind them, which meant that they were walking in a straight line, along which they could return by observing the same precaution. As they reached a tiny grove of wild oranges Will's quick eye caught sight of something which gleamed white against the dark trunks, and the two went over to investigate. There they saw a grisly sight. Coiled in a perfect circle were the bones of an anaconda some fifteen feet in length. Every vertebra and rib, and even the small bones of

the head and the formidable, recurved teeth were perfect, while in all the great skeleton there was not a fragment of flesh or a scale of the skin remaining. Strangest of all, enclosed by the ribs of the snake was the crushed skeleton of a large monkey, which likewise had been cleaned and polished beyond the skill of any human anatomist or taxidermist. Some terrible foe had attacked the great snake while lying helpless and torpid after its heavy meal and had literally devoured it alive. The face of the Indian was very grave as he looked at the gleaming bones before him, and he stared carefully through the adjoining thickets before speaking.

"Puma bad man-eater," he said at last; "cannibal-fish worse; but anciton most dangerous of all. He eat same as fire eats. He kill jaguar, sucurucu, bushmaster, alligator, Indian, white man. He afraid of nothing."

"What is the anciton?" inquired Will, frightened in spite of himself.

Even as he spoke, from far beyond in the jungle came a strange, rustling whisper which seemed to creep along the ground and pass on and on through the woods like the hiss of spreading flames.

"Come," said the Indian, briefly, "I show you." And he led Will farther out into the jungle through which the menacing whisper seemed to hurry to meet them. Soon, small flocks of plain-colored birds could be seen flying low, with excited twitterings, evidently following the course of some unseen objects on the ground. Then there came a rustling through the underbrush, and, in headlong flight, an army of little animals, reptiles, and insects rushed through the jungle. Long brown wood-rats scuttled past, and tiny jumping-mice leaped through the air, guiding themselves with their long tails, while here and there centipedes, small snakes, and a multitude of other living creatures sped through the brush as if fleeing before a forest fire. Suddenly, through a corner of the jungle, thrust the van of a vast army of ants. Through the woods they moved in lines and regiments and divisions, while little companies deployed here and there on either side of the main guard. Like a stream of black lava, the army flowed swiftly over the ground. As with human armies, this one was made up of different kinds of soldiers, all of whom had different duties to perform. Most numerous of all were the eyeless workers, about half an inch in length, armed with short, but keen, cutting mandibles. These acted as carriers and laborers and reserve soldiers, and, al-

though blind, were formidable by reason of their numbers. Larger than the workers, measuring a full inch in length, were the soldiers, with enormous square heads and mandibles pointed and curved like pairs of ice-tongs. These soldiers would drive in each mandible alternately until they met in the body of their victim, and, when they met, they held. Even if the body of the ant was torn away, the curved clinging jaws still clinched and bit. With the soldiers came companies of butchers, whose jaws had serrated teeth which sheared and cut through

The next day Jud and Joe joined in the hunt, leaving Hen to nurse the professor. Following a deer-trail back from the shore, they came to a patch of swampy woods a mile from the lake. There Will discovered a mound some five feet high made of rushes, rotting moss, leaves, and mold.

"Is that a nest of ants?" he called to the Indian, pointing out to him the symmetrical hillock.

Pinto's face lighted up.

"No," he said, "that a nest of eggs. We dig it out, have good supper to-night."

"It must be some bird," exclaimed Jud, hurrying up, "to make a nest like that. Probably one of them South American ostriches—hey, Pinto?"

"You 'll see," was all that the Indian would say as he began to dig into the soft, spongy mass. The rest of the party followed his example. By the time they had reached the center of the mound, digging with sticks and bare hands, the matted, rotting vegetation felt warm to the touch, and this



"A LARGE AGOUTI, IN FLEEING BEFORE THE ANTS, CAUGHT ITS LEG IN A TANGLE OF VINES"

flesh and muscle like steel saws. Besides these, there were laborers and reserve soldiers by the million. Pinto told Will that a large ant-army would take twenty-four hours to pass a given point even when traveling at full speed. As they watched this army, Will saw an exhibition of what it could do. A large agouti in fleeing before them had in some way caught its leg in a tangle of vines and, squealing in terror, tried in vain to escape. Before it could release itself, the rush of the army was upon it, and it disappeared under a black wave of biting, stinging ants, which methodically cut up and carried off every fragment of the little animal's flesh and passed on, leaving behind only a tiny picked skeleton.

As Will watched this hurrying, resistless multitude, although well out beyond the path of its advance, he felt a kind of terror, and was relieved when the Mundurucu started back for camp.

"Nothing that lives," said Pinto, "can stand against the Black Army."

heat increased as they approached the base of the nest. Down at the very bottom of the mound, arranged in a circle on a bed of moss, they found no less than twenty-four white eggs as large as those of a duck, but round and covered with a tough, parchmentlike shell.

Pinto hurriedly pouched them all in a netted game-bag which he had made for himself out of palm-fiber.

"Want to see bird who laid those eggs?" he asked Jud.

"I surely would," returned the old trapper. "Any fowl what builds a five-foot incubator like that must be worth seein'."

"Rub two eggs together and she come," advised Pinto, holding out his bag to Jud.

Following the Indian's suggestion, Jud unsuspectingly rubbed two of the eggs against each other. They made a curious, penetrating, grating noise, like the squeal of chalk on a blackboard. Hardly had the sound died away, when from out of a near-by wet thicket there came a roaring bellow that shook the



very ground they stood on, and suddenly the air was filled with the sickly, sweet scent of musk. Jud turned as if stung by a fire-ant to see a pair of green eyes glaring at him above the jaws of a great alligator which had been lurking in the darkness of the jungle. As it lay there like an enormous lizard, the dark gray of its armored hide hardly showed against the shadows. On either side of the

the rails to his death before a locomotive when one bound to the side would save him. At last, as Will and Joe also began to shout the same words over and over again, the idea penetrated Jud's bewildered brain and he sprang to one side and doubled on his trail. His pursuer however specialized in doubling itself. Unable to turn rapidly on account of its great length, and seeing its prey escaping,

the alligator curved its body and the long serrated tail swung over the ground like a scythe. The extreme end of it caught Jud just above the ankles and swept him off his feet standing him on his head in a thorn-bush, from which he was rescued by Pinto and Will, who had followed close behind. The alligator made no further attempt at pursuit, but quickly disappeared in the depths of a marshy thicket.

"Whew!" said Jud, exhausted, sitting down on a fallen log and mopping his steaming face. "That



"A GREAT ALLIGATOR HAD BEEN LURKING IN THE DARKNESS OF THE JUNGLE"

forepart of the upper jaw, two cone-shaped tusks showed white as polished ivory, fitting into sockets in the lower jaw. Even as Jud looked, the upper jaw of the vast saurian was raised straight up, showing the blood-red lining of the mouth gaping open fully three feet. Then with a roar like distant thunder, the great saurian raised its body, as big as that of a horse, upon its short, squat legs and rushed through the brush at Jud with a squattering gait, which, however, carried it over the ground at a tremendous rate of speed for a creature eighteen feet long. It was Jud's first experience with an alligator, and with a yell he ran down the slope like a race-horse. Unfortunately for him, on a straight line downhill an alligator can run faster than a man, and this one began to overtake him rapidly. As he glanced back, the grinning jaws seemed right at his shoulder.

"Dodge him! dodge him!" yelled Pinto.

At first, Jud paid no attention, but ran straight as a deer will sometimes run between

was certainly a funny joke, Mr. Pinto. About one more of those an' you won't go any farther on this trip. You'll stay right here—underground."

The Mundurucu was very apologetic, explaining that he had not intended to do anything worse than startle the old man, while Will and Joe interceded for him.

"He only wanted to see you run," said the latter, slyly. "Nobody can run like Jud when he's scared."

"No, boy," objected the old trapper, "I was n't exactly scared. Startled is the right word. It would startle anybody to have a monstrophalus alligator rush out of nowhere an' try to swallow him."

"Certainly it would," agreed Will, gravely. "Anybody could see that you were n't scared, you looked so noble when you ran."

Peace thus being restored, the whole party returned to camp, where that night Professor Ditson, who was feeling better, gave a long discourse on the difference between crocodiles, alligators, and caymans.

"If that had been a crocodile," he explained "you would n't be here now. There 's one species found in South America and it 's far swifter than any alligator. Look out for it."

"I most certainly will," murmured Jud.

That night at supper, Pinto proceeded to roast in the hot coals the whole clutch of alligator eggs except the two which Jud had

dropped in his excitement. For the first time in a long life the old trapper refused the food offered him.

"I 've et monkeys an' dragons an' cannibal-fish without a murmur," he said, "but I draw the line at alligator's eggs. They may taste all right, but when I think of their dear old mother an' how she took to me, I 'm just sentimental enough to pass 'em up."

(To be continued)

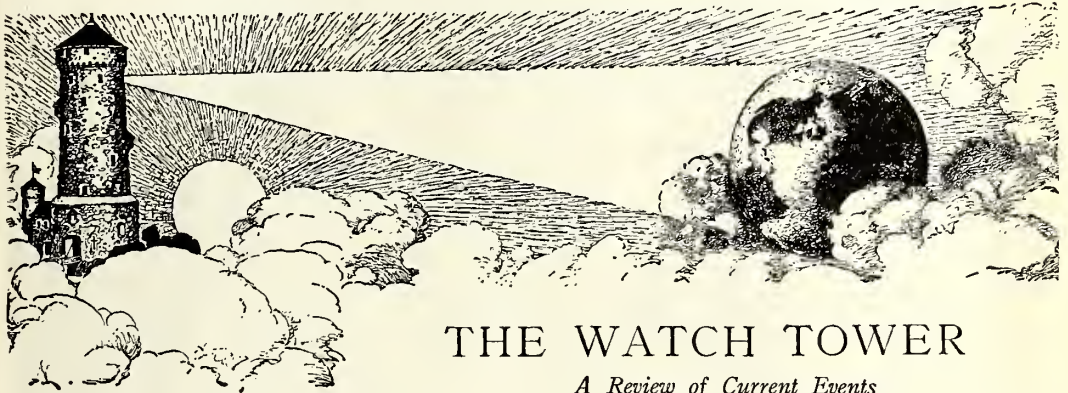

## THE WATCH TOWER

*A Review of Current Events*

By EDWARD N. TEALL

### THE PRESIDENT GOES TO COLLEGE

MOST folks who go to college spend four years there, and then get only a bachelor's degree; but in June President Harding went to Princeton for one day, and came away with the degree of doctor of laws. He went to the New Jersey college town on the pleasant business of dedicating a monument in memory of George Washington, and the soldiers of the Revolution.

The history of this monument may be said to go back to 1783, when the Continental Congress adopted a resolution calling for the erection of a statue to the Commander-in-Chief of the American armies. More than a hundred years later, some Princeton folks took up the idea, formed the Princeton Battle Monument Association, and with the help of Congress and the government of New Jersey raised the necessary funds. The monument stands in a beautiful little park, near the field where the Battle of Princeton was fought.

The Battle of Princeton was a small affair as to number of men engaged, but it was one of the few fields in which Washington was

personally at the front, and it had great influence in restoring American confidence, at a time when things had been going badly.

The monument is massive and beautiful, and carries this inscription:

Here Memory Lingers  
to Recall  
the Guiding Mind  
whose Daring Plan  
Outflanked the Foe  
and Turned Dismay to Hope  
when Washington  
with Swift Resolve  
Marched Through the Night  
to Fight at Dawn  
and Venture All  
in One Victorious Battle  
for Our Freedom

Saecula Praetereunt. Rapimur Nos Ultra  
Morantes.

Adsis Tu Patriae Saecula Qui Dirigis.

The Latin quotation means: "The ages pass away. We, too, are hurried on. O



Thou who guidest the ages, stay to guard our land."

IN Colonial times Princeton was a straggling village of less than a hundred houses along the ancient highway that ran from New York down through Newark, Elizabeth, New Brunswick, and Trenton to the Quaker City on the Delaware, and was the half-way stop. There were several inns and taverns—the Hudibras, the King's Arms, and the Sign of the College were some of them—where the great lumbering coaches drew up to change teams. There, good Mine Host offered excellent "refreshment for man and beast," and there the weary wayfarers got out to stretch their legs and "swap" news and views of public affairs from Boston to Virginia.

Up and down the dusty highway in front of the college rolled an endless tide of traffic; and as the war drew near and nearer, many a student, neglectful of his books, lounged in the tavern yard, or sat before the great roaring inn fire while winter winds howled over the bare mid-Jersey fields, and thrilled to travelers' tales of stirring events in New England and the South: of Boston tea-parties, of Patrick Henry's fiery speeches before the House of Burgesses, down in the Old Dominion. As the spirit of revolution spread abroad in the land, the resolve to submit to no "taxation without representation," the little town in the middle colony became a hotbed of rebellion, far more prominent and widely known than would have been expected from a place of its size. It had the dimensions and the courage of a David going forth to fight a Goliath. . . .

Out of the bitter campaigning of 1777, Nassau Hall came sadly battered. The stout old building was the scene of actual fighting in the Battle of Princeton; its walls long bore the marks of bullets and cannonballs, and the Hessian troops who were



Underwood & Underwood

PRINCETON BATTLE MONUMENT, THE WORK OF FREDERICK MACMONNIES, DEDICATED BY PRESIDENT HARDING

quartered in the building—turning the basement into a stable for their horses!—had torn up the benches and woodwork and used them for kindling. . . .

Hurrah! The war is over, the treaty of peace is signed! And faithful Princeton has her reward. The Continental Congress comes to hold its sessions here (1783), and the little Jersey town is the capital of the nation!

And now down the old highway from headquarters over at Rocky Hill comes clattering into the college town a cavalcade, small, scantily adorned with the pomp and panoply of peace, but sternly martial with

the training of long, hard campaigns; the Chief on his favorite roan charger, and his little escort of Continental troopers. Into the buzzing town they ride, where the taverns are crowded with visitors brought in by the stage-coaches; where students in black caps and gowns gather in the campus to await impatiently the coming of the hero of the day; and where the townspeople and farmer folk from all the country-side kick up a stifling dust into the sultry air of August—while in the college hall the members of the Continental Congress await with magisterial dignity the coming of their guest, that they may formally express to George Washington the nation's gratitude for his services.

Grouped by States, the members occupy the main floor of the hall, the college prayer-room; the galleries are packed with visitors of note and no note; the man who wears his hat, while all other heads are uncovered, is Elias Boudinot, President of the Congress. And now suddenly the whispering hall is hushed; suddenly again a true Princeton shout greets the entrance of the famous general. Then, with measured voice and solemn words, the president of the national legislature voices a nation's gratitude; and, modestly, George Washington replies. And it is all over; so simply was history made in those stirring times.

In this same old Princeton hall it was that, just a little later, Congress received the Dutch Minister, Van Berckel, the first ambassador sent to this country by a foreign power; and here it was that Congress received the first official and authentic news that the treaty of peace had actually been signed, and was on its way to America. Verily, faithful little Princeton had its reward for courage and patriotism! . . .

When next you go to visit Brother Tom or Jack in his room on the historic Princeton campus, or to cheer while he stoutly defends the Orange and Black against the onset of the Bulldog, get him to take you over to Rocky Hill—it's only five miles cross-country—and show you the headquarters where Washington stayed in 1783. And as you stand at a window of the old house and look out over the peaceful hills and valleys where, in 1777, the patriot and hostile armies stormed back and forth, fighting out the question of American independence, recall this little story:

Something more than twenty years ago the estate, Rockingham, at Rocky Hill, which had been Washington's headquarters,

was rescued from oblivion. The fine old colonial house had been allowed to degenerate into an Italian tenement. But even then, says Professor Collins of Princeton, in his book "The Continental Congress at Princeton," "amid all the squalor and filth, the Blue Room," Washington's reception-room and office, "was kept unused and immaculate. Its bare floor and plain walls, and the blue dado that gives it its name, were spotless, while in one corner stood a rude table on which day and night a taper burned."

Perhaps besides "Italian deference to tradition and a revered name," the glow of that taper was kindled from a spark of the fires of freedom that have ever burned clear and bright on the Princeton altar.

#### GERMANY TO-DAY AND TO-MORROW

IT'S quite a while, is n't it, since we've had anything to say about Germany? There has n't been anything very exciting to talk about in what was once Kaiserland. Germany is plugging along, doing pretty well.

There is discussion all the time about reparations, and France and England have come uncomfortably close to a serious falling-out over that extremely important matter. But the flurries pass, the payments are made, and—so far—the peace has been kept.

Germany is developing relations with Russia that may sometime make trouble—or that may, for all the "croakers" can really tell, be advantageous to both Russia and Germany, without hurting any one else.

Talk about a restoration of the monarchy flashes up now and then—as it naturally would; but it does n't amount to much, and it lets off steam.

The Germans are working hard, and for small pay. They are sending cheap goods into the world's markets, and American manufacturers and workmen have to compete with them. This helps to give some folks the pleasure of feeling badly about the nation beaten in the field, coming off best in the long run. It has also given the Republican orators in Congress a good argument for their high protective tariff.

So long as the world can be sure that Germany is working with honest desire to resume her place as an honored member of the family of nations, and not with secret intentions of continuing sometime her schemes of conquest and domination, every sign of progress in Germany is welcome.



### ON THE ROOF OF THE WORLD

EVEN in these days of radio it takes a long time to get news from some parts of the world. It was mid-June when we learned that three members of the Mr. Everest Expedition, Messrs. Mallory, Summerville, and Norton, had climbed in May to a height of 26,800 feet, within 2200 feet of earth's highest point above sea-level. Later a despatch came, saying that two members of the expedition were trying to complete the ascent. And then, on June 25, we learned that the last desperate attempt had gained only one hundred feet.

The story of the ascent is one of the glowing chapters in the history of exploration.



Times Wide World  
MOUNT EVEREST CLIMBERS  
REACHING 23,000 FEET

A preliminary expedition last year studied the possible lines of attack, and selected the one that offered the best hope of success. From most directions the ascent is utterly impossible by the presence of cliffs hundreds of feet high, with sides as straight as the walls of the Woolworth Tower. Anorth-western slope was finally selected as the most passable, and from a camp estab-

lished there the final climb was started.

From that point, it is likely, the difficulties offered by surface conditions are not worse than those encountered by climbers in the Alps. But it is one thing to meet those difficulties at heights of less than 20,000 feet, and another thing to strive to overcome them in the rarefied atmosphere of Mt. Everest. The oxygen bottle, with mask and tube, weighs more than thirty pounds. Probably the conquest of earth's highest point, if it is ever achieved, will have to wait for the discovery, or invention, of some way to supply oxygen to the lungs without the necessity of the climber carrying so much handicapping weight.

Some members of the expedition doubt if any human being will ever stand upon that lofty peak. Certainly they have done all that men of brains and grit could do! Their record of 26,900 feet, if the latest despatches are correct, exceeds by 2367 feet the best previous record made, by the Duke of Abruzzi, twelve years ago.

### GREAT AMERICAN WOMEN

A CHILEAN writer asked the National League of Women Voters to name the twelve greatest American women now living. The twelve were to be selected from representatives of as many different occupations as possible, and from women who had "made good" without help from fathers or husbands.

A New York newspaper offered this list, which we think will interest many of our readers; especially, of course, the girls: Geraldine Farrar, opera singer; Edith Wharton, novelist; Carrie Chapman Catt, suffragist; Molla Mallory, tennis player; Alice Paul, suffragist; Ida Tarbell, writer; Jane Addams, sociologist; Amy Lowell, poet; Minnie Maddern Fiske, actress; M. Carey Thomas, college president; Mary Pickford, movie star; and Agnes Repplier, essayist.

The newspaper that published the list remarked that we have no business woman like the Viscountess Rhondda of England, no such woman scientist as Mme. Curie of France.

Other names suggested for the honor of inclusion in the list were those of Eliza M. Mosher, physician; Frances Hodgson Burnett, author; Annie S. Peck, explorer; Mrs. H. H. A. Beach, composer; Isabel M. Lewis, astronomer; and Cecilia Beaux, painter.

The newspaper from which the list is taken—it is the "New York Times"—made this extremely interesting comment: "The twelve greatest women in the United States are women who have never been heard of outside of their own homes, and seldom appreciated there; . . . who at last go back to those private aspirations buried twenty-five years ago, discover that it is too late to do anything with them—and smile. They are the greatest women, but they are never heard of in their lifetime, and their memory lives only in their children's vague impression that Mother must have been rather clever before all her ideas got out of date."

This is not for the girls only, after all; it has a helpful suggestion for all of us who live ordinary lives, without fame or public

recognition—just doing the day's work day after day, in school or home, factory, shop or office, holding up our part of the load. We don't have to be great to be useful and worth while.

And—here is the special WATCH TOWER point of it all—it is exactly the great mass of plain, ordinary citizens, steady and loyal, that makes America safe and secure.

were in such bad shape that no investment in Mexico could be regarded as safe.

In June the Mexican Minister of Finance, Mr. de la Huerta, and the international commission of bankers brought to a successful close a long discussion of measures by which the republic's financial affairs might be set in order. It was decided that the Mexican Government should begin, next



Underwood & Underwood

"IN THIS TEMPLE, AS IN THE HEARTS OF THE PEOPLE FOR WHOM HE SAVED THE UNION, THE MEMORY OF ABRAHAM LINCOLN IS ENSHRINED FOREVER"

### LINCOLN'S SHRINE

IN all the world there is no more beautiful and majestic monument to the memory of a great benefactor of mankind than the Lincoln Memorial at Washington. This memorial, a temple-like building standing at the head of a lagoon in which its beauties are effectively reflected, was dedicated by the President in May.

Just above the statue of the Great Emancipator an inscription, written by Mr. Royal Cortissoz, is chiseled into the wall. It has the beauty of simplicity: "In this temple, as in the hearts of the people for whom he saved the Union, the memory of Abraham Lincoln is enshrined forever."

American boys and girls who have the good fortune to visit the nation's capital must see this national monument to the best and noblest man that boys and girls ever had for a hero.

### MEXICO MOVES AHEAD

SINCE 1914 Mexican affairs have been pretty badly muddled. The request of the Obregon government for recognition by the United States could not be granted while the country was still subject to revolutionary disorders, and—especially—while its finances

January, to resume payment of interest on its bonds. Interest on them, which has not been paid during the last seven or eight years, was turned into a separate debt.

Perhaps you are not a banker and don't expect ever to be a banker—or even, perhaps, to have money enough to involve you in financial affairs on so large a scale. And perhaps you wonder why THE WATCH TOWER should discuss financial matters like these. There is a very good reason. When a nation can't or won't pay its debts, the consequences spread far and wide. Other governments can not deal with it satisfactorily. Investors can not place their money in its enterprises safely. And the uncertainty and losses affect the prices of goods we all buy, and the supply of them in the market.

The United States Government has refused to do business with the Soviet government in Russia until it makes a definite statement of its intentions in regard to Russian debts and the safeguarding of foreign property and investments. National business matters are very much like those of individuals. You have to know whom you can trust; and when a man or a nation refuses to pay bills, other men and nations prefer to deal with some more reliable party.



A man or a nation that is in trouble and can not pay can make arrangements and get help to tide over the bad time; but a man or a nation that tries to side-step fair obligations inspires no confidence and deserves no trust.

By agreeing to the arrangement for payment of its honest debts the Mexican Government proves that it means to play fair,

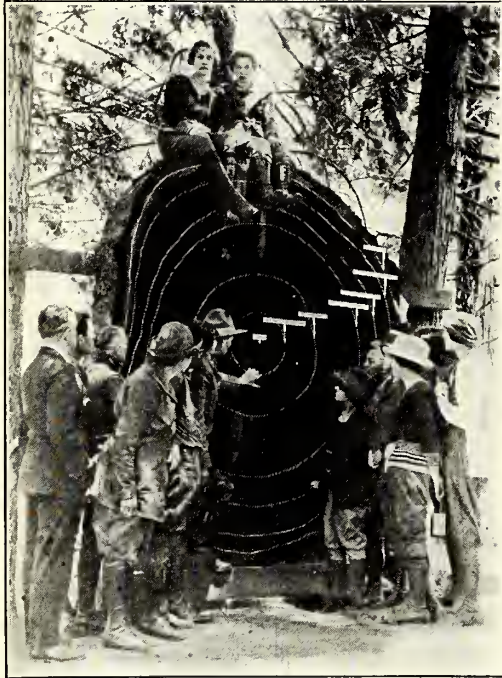

Times Wide World

GIANT TREE, 996 YEARS OLD. THE SPACE BETWEEN THE NATURALIST'S FOREFINGER AND THUMB MEASURES THE SPAN OF A MAN'S LIFE

and improves greatly its chances for early recognition by the United States Government.

### THE STORY OF A TREE

IT was, for THE WATCH TOWER, a current event when they cut down a tree in the Yosemite National Park and told us it had been standing for nine hundred and ninety-six years. Our interest is not to be discouraged by the fact that as the age of trees is counted in the Yosemite this is only a young tree—not even a middle-aged one, seeing that “Grizzly Giant,” the thickest of all those mighty trunks, has survived the storms of forty centuries! Any tree that has stood up for nearly a thousand years is old enough for us! In fact, it suits us better than the four-thousand-year-older, because it’s a wee

bit easier to stretch the imagination over its history.

This tree was five hundred and sixty-six years old when Columbus brought his men ashore, ’way off on the other side of the continent. It flourished when our Declaration of Independence was signed. It stood calm while the Civil War was fought. Its strength held all through the long way of our history.

Why, we could preach a sermon on that tree! The central idea would be the advantage of living your own life and ’tending to your own business. We don’t want to be too much like trees, but they do offer us a lesson in one kind of strength and success.

That old Yosemite tree must have seen many and many a brother go down in the storms because it was n’t sound and fit for just whatever it is that a tree has to do in the world.

### THROUGH THE WATCH TOWER'S TELESCOPE

SHIP subsidy, national bonus, tariff—the spring of 1922 brought busy days in Congress. The coal strike and the threat of a railroad strike were important among the obstacles on the path of the “return to normalcy.”

IRELAND meets and survives more crises than any other country we have ever heard of. The vote for members of Parliament in June was one of them. As this WATCH TOWER was written, reports were that the election had gone off pretty quietly, and that the result appeared to favor the treaty-and-constitution party. The proposed constitution offered Ireland the position of a dominion in the British Empire.

It is hard to keep track of things in China. But it looked in June as though Sun Yat-sen, president of the South China Government, seated at Canton, had been badly set back. All that we can be sure of is that most of the Chinese leaders favor a united China, but each one thinks the union ought to put his faction in first place.

SENATOR LAFOLLETTE attacked the Supreme Court, which he says is defeating the purposes of legislation by Congress. Congress passes the laws, and the Supreme Court tests their constitutionality. It would be a sad day for America if our people were ever to lose their faith in the Supreme Court.

## NATURE AND SCIENCE FOR YOUNG FOLK



Underwood & Underwood

A SMALL BOAT EQUIPPED WITH MECHANICAL CONTROL MACHINE

### PILOTLESS AIRCRAFT AND SEACRAFT

AMONG the most interesting of modern inventions are those devices by means of which the movements of boats and airplanes can be controlled entirely from the outside, so that they can be made to travel toward a given destination, though they carry neither pilot nor crew. Some of these devices are operated by wireless waves. Equally interesting, and even more advantageous, perhaps, for certain purposes, is the mechanical boat invented by Mr. E. M. Winkley of Rowley, Massachusetts. When this has been set going, it follows a predetermined course with perfect accuracy from start to finish, even though the course is by no means straight but consists of a number of "legs" running in different directions. Yet this modern "Flying Dutchman" has not even a ghost of a pilot on board!

To comprehend the principle upon which it operates, we must first consider the method by which a pilot steers a craft in foggy weather, when his faithful friends, the stars above, are no longer visible. In such a case, he has recourse to what is known as dead-reckoning. This means that he makes a careful calculation of all the elements that control the motion of the boat. These in-

clude the rate of speed at which it travels and the corresponding distance which it covers in a given time. These depend, primarily, on the power of the engine and the rapidity at which it is being driven, and, secondarily, on such modifying factors as winds, currents, and tides.

The navigator must be equipped with a chart showing not only the direction to be followed and the necessary twists and turns which he must make in order to reach his destination, but also such possible obstacles as rocks or sunken reefs; he must also be provided with a compass and a timepiece.

He first plots upon the chart the course to be followed, and then makes a minute calculation of the exact time required under the given conditions of wind and weather, currents and tides, to cover each leg of the course. If his calculations are correct, to begin with, and the changes of direction are accurately timed, he reaches his goal in safety, even though the weather is so thick that he can't see his hand before his face.

The Winkley steering device is an ingenious arrangement by means of which seacraft or aircraft—and for that matter, automobiles as well—can be made to follow a predetermined course laid out by this same sort of dead-reckoning. Its advantages in



war or in peace are obvious. In the former case, for example, an armored tank, an aerial torpedo, or a submarine loaded with high explosives could be sent with unerring aim toward a point to be attacked within the enemy's lines without risking the lives of any of our own men. For example, one of the most famous exploits of the Great War was the daring dash by the British to Zeebrugge, on the Belgian coast, in order to block the exit from a German submarine base. This was successfully accomplished, and one happy result was the undoubted saving of the lives of many of our American

vice, a steering device, and a stabilizing device.

A gyroscopic compass is a compass which maintains a north-and-south direction by reason of the rapid rotation of a gyroscope, the latter being an instrument based upon the same principle as a spinning top. As long as the rotation is sufficiently rapid, the axis of the gyroscope always points in the same direction. This is important, because it thus furnishes a base-line. A base-line is the fixed line which a navigator uses as a basis for his calculations in the dead-reckoning described above. One advantage of the gyroscopic compass, too, is the fact that it is not affected by the presence of any of the metal parts of the boat, which sometimes cause the ordinary magnetic compass to veer from its true direction. The timing device is a carefully regulated and adjusted time-piece. The steering device is an instrument, as its name implies, for swinging the craft into a new direction at the time appointed for it to start on a new leg of its journey. The timing device and the steering device must, of course, be synchronized; that is, they must be so adjusted to each other as to exactly cooperate in their action. The stabilizing device is not needed for an ordinary power-boat, such as is shown in our picture; it is intended for use when the apparatus is applied to submarines or to aircraft,—in which case, of course, we have three dimensions to consider, not merely length and breadth, but depth or height, as the case may be,—and holds the craft upon a steady keel.

It is very wonderful to see the precision of movement attained by a craft operated by this apparatus, which might be termed a sort of mechanical brain. Moreover, it is comparatively light, weighing less than one hundred pounds, so that it can be used on quite small boats. It is said to be absolutely proof against error except, of course, such possible errors of calculation as may be due to the human fallibility of the navigator who charts the course. M. TEVIS.

#### NOW GROW WHEAT NEAR ARCTIC CIRCLE

THE Alaska Experiment Stations of the United States Department of Agriculture have demonstrated that it is possible to raise locally a large part of the wheat needed by those living in the Territory. A recent report states that in the summer of 1921 a crop of 3500 bushels of wheat was produced in the vicinity of Fairbanks. This wheat,

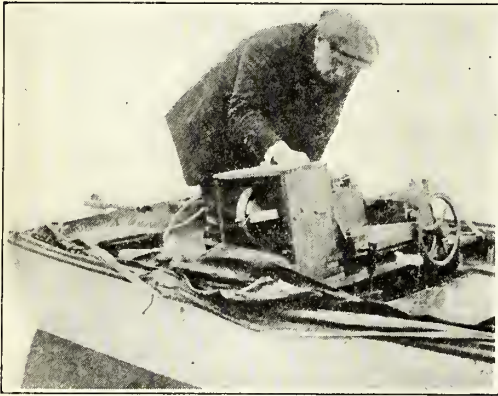

Keystone View Co.

A CLOSE-UP OF THE CONTROL SHOWING GYROSCOPE

troops, who might otherwise have been sacrificed to these hornets of the sea. But though this successful feat was accomplished in less than a quarter of an hour, nearly six hundred of the gallant sailors and marines who had volunteered to perform it were either killed or wounded. Yet the same thing might have been achieved with no loss of life had the craft used for blocking the submarine exit been steered to its goal by the Winkley device and without a man on board. The inventor, indeed, offered this invention to the United States Government in 1918, but, before the final tests could be made, the Armistice was happily declared.

But it is not only in time of war that human lives may be in peril; many is the brave sailor who has perished within sight of port when his ship was wrecked on some rock-bound coast in a tempest too severe for the life-boats to venture out. But by means of the Winkley apparatus, an unmanned craft might carry a life-line across the stormy surface to a sinking ship.

The apparatus in question consists of four parts—a gyroscopic compass, a timing de-

raised from seed originally imported from Siberia in 1914, is made into flour at a mill in Fairbanks and supplies the 1500 people who live there. The grain is hard and the flour of excellent quality.

Oats and barley, in addition to wheat, are being grown in the interior valleys. The aim of Alaskan agriculture is to grow sufficient food to supply all those engaged in industrial occupations in the Territory.

#### VICES AND VIRTUES OF THE CACTI

WE all know that the most worth-while people are not always the handsome ones, but those that have most "to them." This is just as true of plants, and a case in point is the cactus family, those queer, freakish, unfriendly plants which Nature has fitted to live where soil is poorest, sun hottest, and water scarcest. It might seem that not much was to be expected in these circumstances; yet the cacti, besides being remarkable to look at, are full of valuable qualities and possibilities.

They are a large family, of which only a few members are found in the United States, though virtually all are natives of this continent. But it is their variety that makes them fascinating—variety of size, shape, color, and, what is most to the purpose, of usefulness. In size they run from the inch-

some resemblance to trees and bushes, there are others like rows of organ-pipes, others that remind you of old, gray-haired men, or of long green snakes; others are like tiny



THE NEST OF THE CACTUS-WREN IN A CHOLLA

pincushions, others like barrels, posts, footballs, starfish, crabs, and one that looks like nothing so much as a lump of rough gray rock.

The one feature which has given the cacti



CHOLLA CACTUS ON A DESERT HILLSIDE

high *Mamillaria* to the giant *Cereus* of Arizona, which may reach to fifty or sixty feet. In shape, while there are cacti with

a bad name is their ferocious prickliness; but then, that is for necessary self-defense. In order to live through the long seasons of



drought, they need to store up lots of moisture when they can, and what chance would they have against the thirsty desert animals if they were not well armed? Well armed they certainly are, some like the "pancake cactus," with myriads of prickles almost too fine to see, others, like the cholla, with barbed needles two inches long, and the *biznaga*, with great four-inch spikes that can rip and gash like a wildcat's claws. The Indian pony that I rode on the desert, wise as he was in the ways of cactus, was not wise enough always to avoid being stabbed by some vicious *mancaca-ballo* (horse-lamer), or *cegador* (blinder), as the Mexicans call them.

But now look at the better side of the cacti. For one thing, they produce exquisite

a good substitute for string-beans; and an Indian on the desert once introduced me to what he called *ko-pash*, the young buds of a cactus, which I found to make a very fair

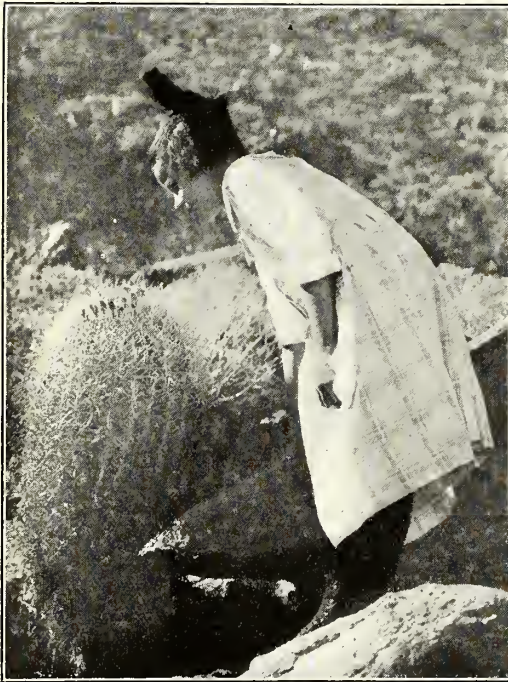

THE BIZNAGA, OR BARREL CACTUS

flowers, many of them never seen except by the chance traveler on the desert. They bear some good fruits, too—one which takes the place of lemons, another with a flavor like strawberries, another like cranberries, while one kind is known as "Barbadoes gooseberries." In candy stores you may buy cactus candy, looking something like crystallized pineapple and with a pleasant, delicate taste; and in Mexico you find in the markets "*queso de tuna*" or cactus-fruit cheese, very sweet and luscious. There are cactus vegetables, as well. One sort makes

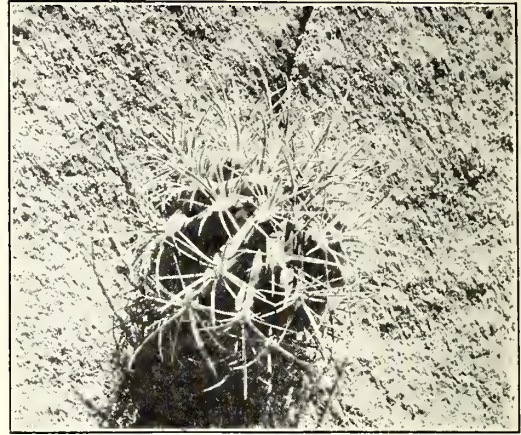

CACTUS THORNS THAT MAKE PHONOGRAPH NEEDLES

kind of Brussels sprouts. (My young girl friend in the picture is just making the acquaintance of this rather unpleasant-looking cactus: you can see the buds on the top.)

Even apart from food value, the cacti are full of practical possibilities. Before the discovery of America, the natives cultivated one kind on which lives the cochineal insect, from which they made a brilliant scarlet dye. Another, when hollowed out, may be used as a kettle in which to cook food. Others provide needles, brushes, and combs, and the long hard spines of the *biznaga* have been found to make excellent phonograph-needles. Then, as is well known by desert people, water can be found, in case of need, by cutting into the big "barrel cactus." And I always count it a virtue in the one species that is cruelest of all to men, that it makes a safe nesting-place for a little favorite of mine, the cactus-wren, who, with her nest deep in the heart of a cholla, can defy snakes and other enemies to do their worst.

J. SMEATON CHASE.

#### STRAW AS A BUILDING MATERIAL

A FRENCH inventor named Feuillette has had the brilliant idea of making use of straw as a building material. Straw, of course, has been used as a roofing material, in the form of thatch, for many centuries. It has the virtue of being a poor conductor of heat, thus tending to keep the house it covers warm in the winter and cool in the summer. It is, however, very inflammable, for which reason

it is unsuitable for roofing in towns and cities, however picturesque and comfortable in country villages. M. Feuillet, however, does not propose to use straw for roofs, but for the inner and outer walls of dwellings, the roof being composed of zinc, slate, or tiles, as usual. The framework of these houses consists of wood or metal, while blocks of compressed straw are used to fill in the spaces, instead of stone, brick, etc.

To begin with, a light foundation is laid down and covered with a layer of water-tight material to prevent moisture from rising by means of capillary attraction; the framework of the building is then set up and the spaces between the posts and beams filled in with the blocks of compressed straw. The width of these straw blocks is equal to the desired thickness of the walls, while their length corresponds to the distance between the upright posts of the framework. The two sides of the wall are then enclosed between fine-meshed wire netting which is afterwards coated with a suitable compound; the inner wall next receives the usual covering of plaster, while the outside is finished with rough-cast cement. These houses are cheap, easily built, and very uniform in temperature, thanks to the cushion of air enclosed in the interstices of the straw building-blocks. Such buildings are, of course, intended merely for villages, country cottages, and garages. It is expected that they will be specially useful in the devastated regions of northern France. Instead of straw, the filler may be composed of reeds, rushes, broom, brambles, and similar material.

DONOVAN MCCLURE.

#### APES THAT TEST MONEY

THE people of Siam are very fond of keeping monkeys of various kinds as pets. Owing to their close association with human beings, these creatures become very intelligent. One of the most remarkable things that these monkeys can do is to test money. In Siam, there is a large amount of counterfeit money, perhaps more than in any other country in the world. As a consequence, the lot of the merchants is a difficult one. They have, however, surmounted the trouble to a large extent by making use of apes to test the coins. Sitting by the side of each merchant is to be seen a solemn-faced ape. Every piece of money handed to his master is at once given to the ape. The animal tests the coin with his teeth. If it is good, he throws it into the money-box; but should it be bad,

he flings it to the ground, making weird noises to signify his anger. The strange part about the business is that no white person has ever yet been able to discover how the apes tell the good money from the bad. The merchants politely refuse to explain how the creatures are trained to carry out this useful office. The only sure thing about the affair is that the apes never make a mistake. Even the most carefully made counterfeit coin fails successfully to pass the examination of the apes. Those who make a practice of trading with bad money feel that it is hopeless to pass the coin where an ape is employed as cashier.

S. LEONARD BASTIN.

#### A CUBICAL BUBBLE

MOST people think that bubbles can not be anything but spherical; but by a little experiment it is easy to make one that is cubical in shape. First of all, prepare out of iron wire an outline cube measuring about three inches. Fix to the upper part of this a small handle as shown in the diagram. If very

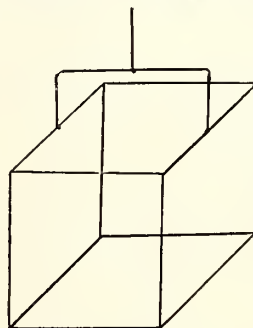

WIRE OUTLINE FOR CUBICAL BUBBLE

smooth wire is used, it is advisable to roughen the surface somewhat with a file. Mix a strong solution of soap and water, and add one third of glycerin to two thirds of the soapy mixture. Put the solution into a bottle, shake it well, and set it aside for a while. After an interval, a clear liquid

rises to the upper part of the container.

Place some of the solution into a cup and then immerse the wire cube. There should be a sufficient amount to cover the cube completely. Draw it out carefully and examine it. In the center there will be a curious, square sheet of film, every side of which is joined to the edges of the cube. Now put only the lower face of the iron wire cube into the liquid, and a remarkable change will come over the interior. Right in the center there will appear a small cubic bubble, whose borders are united to the wire frame. As can be seen, this cube is actually formed by the union of six pyramids with flattened tops. Every part of the film is bright with the most exquisite rainbow hues.

S. LEONARD BASTIN.



## FOR VERY LITTLE FOLK



"LOOK VERY CLOSELY, SOMETIME, AND YOU CAN SEE THEM BOTH"

### A FAIRY COMPROMISE

By CLARA I. JUDSON

ONE bright summer day, two little fairies met out in a big front yard.

One little fairy was named Shadow, because he was one of the fairies of Shadowland. He was dressed in soft, shimmery clothes of dull gray and brown, and so dark were his clothes and so quiet his manner that you would never have guessed he was there—at least, you would n't have guessed unless you looked *very* hard, and that 's something most folks don't do!

The other little fairy was named Sunbeam. He was dressed as brightly as the sunshine, and his manner was as gay and joyous as a summer breeze. As he slipped around over the earth, he got a welcome everywhere, and he always had a pleasant word and a bright smile for every one he saw. He really was a jolly fellow.

On this particular morning, Shadow had been working down in among the grasses, stretching tiny gray nets from stem to stem. "Now if only to-day stays cloudy," he said to himself, "I can make a lovely little home for myself here under this wonderful old elm-tree."

But he failed to reckon on our little friend, Sunbeam!

Just when Shadow was nearly through and was congratulating himself on the beauty of the home he had made, who should come slipping through the tree but little Sunbeam!

"Good morning, Friend Shadow," said Sunbeam, with a gay flourish of his golden cap; "and what are you doing here this morning?"

"I 'm making me a home here under this

elm-tree," replied Shadow. "See how I have woven my nets of gray? See how I have made my nest?"

"Yes, I do see," said Sunbeam, cordially; "but what are you going to do with it now that I am come?"

"Oh, dear!" exclaimed Shadow, in distress, "you don't mean to say that you are going to stay here and spoil my home! I was so sure that to-day would be a cloudy day! Can't you please leave some little place for me?"

Sunbeam thought a minute. "Indeed, I'd like to," he said agreeably; "but what am I to do? The grass under this old tree sent up word that it needed warmth and sunshine, and my Mater Sun sent me here to this very spot to spend the day. I wish I could go somewhere else; it seems to me I am always chasing you around, and I don't like it. But I have to obey Sun—so what can I do?"

And poor little Sunbeam looked really distressed and unhappy.

Shadow could n't stand that—he liked to see the Sunbeam happy; so he immediately forgot his own disappointment and plans and said, "Don't you worry about chasing me—of course, you can't help it, I know that very well. But I just thought maybe we could think of some plan, so we both could have a place here. Then the grass could have some sunshine, and I could have a little corner for my home. I'll declare, sometimes, in these bright summer days, I don't know where to go! I get fairly tired moving so often."

"Of course, we can make a plan," said Sunbeam, earnestly. "I'll tell you what we can do. You have half the space under this old tree, and I'll have the other half. You won't mind moving around a bit if



"SHADOW HAD BEEN WORKING, STRETCHING TINY GRAY NETS FROM STEM TO STEM"

you're sure of staying under this same tree, will you?"

"Indeed, I'll not!" cried Shadow. "I'll be glad for my half just anywhere!"

And so it was arranged.

Ever since that day, the space under the big old trees belongs half to Sunbeam and half to Shadow.

Look very closely, sometime, and you can see them both.



"OH, DEAR!" EXCLAIMED SHADOW, IN DISTRESS, "YOU DON'T MEAN TO SAY THAT YOU ARE GOING TO STAY HERE AND SPOIL MY HOME!"



# ST. NICHOLAS LEAGUE



BY MARJORIE E. ROOT, AGE 16  
(HONOR MEMBER)

To this midsummer issue of ST. NICHOLAS the boys and girls of the LEAGUE have contributed a generous budget of prose and verse and picture well worthy to rank in interest and merit with the main contents of the magazine. In winter or summer, through school-days or holidays, year in and year out, our young folk never fail to respond nobly to the opportunities offered by the LEAGUE competitions to cultivate their talents for writing, drawing, photographing, and puzzle-making, and always to the delight of their fellow-members and their own advancement. Rarely has this cheery fact, moreover, been better illustrated than by the stories, verses, and pictures that appear this month. For all who love the sea—and who does not?—there are up-to-date tales of how man marvellously overcomes or unflinchingly faces its dangers. Read, for instance, on the opposite page, that amazing incident of the *Lusitania's* sinking and the seemingly miraculous escape and reunion of two of her ill-fated passengers; and, on the next page the noble heroism with which an American naval officer, in a similar emergency, gave his life to save that of another.

By contrast to these epics of the sea, there are several admirable bits of description or little narratives in lighter vein, but of a rare human quality. And each of these little prose offerings is matched by an equally clever piece of verse. Lastly, there is the pictorial element—a fine array of excellent drawings and effective photographs, most of them of a timely nature for the season of holiday sojourns at the seashore or among the hills.



"A HEADING FOR AUGUST." BY EILEEN BLACKBURN, AGE 15. (SILVER BADGE)

## PRIZE COMPETITION No. 269

(In making awards contributors' ages are considered)

**PROSE.** Silver Badges, **Frances G. McDonald** (age 13), Canada; **John Basye Price** (age 15), California; **Katharine Burton** (age 14), Ohio; **Frances E. Hervey** (age 14), Pennsylvania; **Caroline E. Stafford** (age 12), Maryland; **Arthur C. Watson** (age 12), Louisiana.

**VERSE.** Gold Badge, **Eleanor F. Fisher** (age 14), Pennsylvania. Silver Badges, **Constance MacDougall** (age 13), New Jersey; **Elizabeth H. Parsons** (age 13), Connecticut; **Zarepha Sallume** (age 12), Michigan; **Patsy Kelley** (age 15), Pennsylvania.

**DRAWINGS.** Gold Badges, **Alice L. T. MacLean** (age 15), New York; **Helen Sewell Johnson** (age 15), District Columbia; **Howard B. French** (age 16), New Jersey. Silver Badges, **Eileen Blackburn** (age 15), New York; **Lois Gilbert** (age 14), Ohio; **Elizabeth Flinn** (age 13), Georgia.

**PHOTOGRAPHS.** Gold Badges, **Helen A. Sturm** (age 15), Ohio; **Madeleine Curtis** (age 14), France. Silver Badges, **Trowbridge H. Sweet** (age 10), New Jersey; **Eleanor Wayman** (age 15), California; **Marian Welker** (age 17), New York; **Letty Curtis** (age 14), France; **Bill Hayden** (age 13), New York; **Phillips L. Boyd** (age 17), Massachusetts; **Henry Bunting** (age 11), Wisconsin.

**PUZZLE-MAKING.** Silver Badge, **Isabelle Roberts** (age 16), Missouri.



BY HELEN A. STURM, AGE 15. (GOLD BADGE. SILVER BADGE WON MARCH, 1922)



BY MADELEINE CURTIS, AGE 14. (GOLD BADGE. SILVER BADGE WON DECEMBER, 1921)

"MY FAVORITE NEGATIVE"



BY MARIAN WELKER, AGE 17  
(SILVER BADGE)

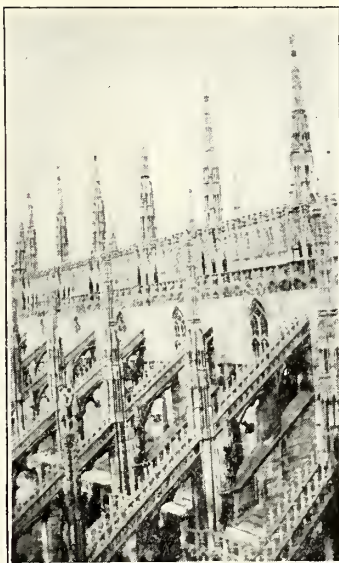

BY LETTY CURTIS, AGE 14  
(SILVER BADGE)

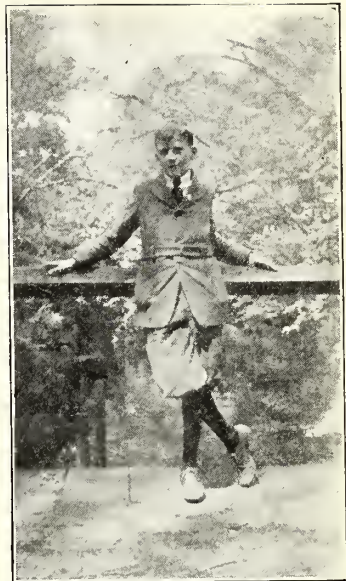

BY JOHN W. BODINE, AGE 10

"MY FAVORITE NEGATIVE"

## AN OCEAN ADVENTURE—A TRUE STORY

BY FRANCES G. McDONALD (AGE 13)  
(Silver Badge)

EVERYBODY remembers well the sinking of the *Lusitania*.

My aunt and two friends, Mr. and Mrs. Smith, were on board. They were at lunch when they were startled by hearing a steward yell, "Close the portholes!"

My aunt lost sight of Mr. and Mrs. Smith, and she and the man beside her started quickly to do as the steward had asked, but they found the boat tipped so much that they had to leave them and make for the door. When they reached the deck, the man with my aunt asked her if she thought she could swarm down a steel hawser, which was hanging over the side. She said "Yes." She had been taught to cling with her feet, so she managed pretty well, but the man who followed, clung with his hands and they were badly cut.

It was a long way between the hawser and the sea, so my aunt had to let go and drop; she went down so far that she thought she would never come up.

When she did she was picked up by stokers and was in their boat for hours, helping to bail the water out with one of her shoes.

When Mr. and Mrs. Smith left the dining-room, they said good-by to each other, for they thought they would never meet again. Mr. Smith put Mrs. Smith in a boat and waited until the last himself.

The boat Mrs. Smith was in capsized when the *Lusitania* sank, and she was sucked into one of the funnels by the water. When the water struck the furnace it exploded and she was shot up again, where she was picked up by a boat and eventually rescued by the same boat her husband was in. You can imagine their joy when they recognized each other!

## DAY-DREAMS

BY ELEANOR F. FISHER (AGE 14)  
(Gold Badge. Silver Badge won March, 1922)

WHEN off in meadows green I lie,  
Set free from every care,  
While gazing upward toward the sky,  
I see things wondrous fair.

Fairy courts and palaces,  
With moats and turrets tall,  
A mystic isle, a temple white,  
A fountain and a wall.

And clouds of crimson, pearl, and gray,  
Like fairy ships at sea,  
Sail o'er a sky of azure blue  
And bring fair dreams to me.

## A STORY OF THE SEA (A True Story)

BY JOHN BASYE PRICE (AGE 15)  
(Silver Badge)

FROM time immemorial there have been stories of sea-serpents. But nearly all of them have been explained by natural causes. A group of porpoises, a sea-lion, or a giant squid, each have been mistaken for a sea-serpent. There is one story, however, which can not be explained by reference to any known animal. The story is this:

In 1848, H. M. S. *Dædalus* was cruising off the coast of South Africa. Suddenly something was seen approaching the ship. It came very near the vessel and then was observed to be a long, serpent-like animal about sixty feet in length, with the head and neck about four feet long and sixteen inches thick. The head was more like that of a seal than that of a snake. The color was dark brown, with the throat yellow. After the captain and several officers and men had



observed it for some minutes, it disappeared. The captain made a report of the occurrence, and, together with a drawing made immediately after, sent it to the Lords Commissioners of the Admiralty.

The question at once arises as to what the thing was. Its appearance was testified to by too many respectable people for it to be a hoax. The shape of the head as shown in the drawing proves that it was not a serpent. A sea-elephant has been suggested as the solution to the problem, but the sea-elephant has a trunk, which would certainly have been seen if the animal had had one. It could not have been a squid, and the captain declared that it was not a seal. It would seem certain, therefore, that there is some monster in the seas which is unknown to science.

This may seem impossible, but remember the okapi, discovered in Africa in 1902.



"AN OBJECT OF INTEREST." BY ALICE L. T. MACLEAN, AGE 15  
(GOLD BADGE. SILVER BADGE WON OCTOBER, 1920)

### A TRUE STORY OF THE SEA

BY FRANCES E. HERVEY (AGE 14)

(Silver Badge)

MINE-sweeping, a dangerous occupation in itself, was made more dangerous by the treachery of the sea.

One morning in a rough sea, the trawler *Richard Bulkeley* was sailing along, sweeping mines, when an exceedingly serious accident occurred. It was occasioned by an exploding mine which destroyed the trawler's hull. Other trawlers in the vicinity had seen her disaster and rushed to her assistance. They succeeded in rescuing sixteen men and two officers, but the treacherous sea wrested six men and the commanding officer from possible rescue.

Commander Frank R. King, U. S. N., stood on the deck until, as he thought, every man had succeeded in escaping. He was about to jump from the doomed ship when a man, who had been stunned by the terrific shock of the explosion, struggled to the deck. The commander had a life-belt—the dazed man had none! Not hesitating an instant, Commander King unbuckled his precious life-belt and hastily fastened it about the other man.

Having succeeded in helping the stunned man to safety, Commander King turned to try and find a means for his own escape. But the sea at that moment gave a tremendous pull at the *Richard Bulkeley* and with a sudden final lunge she disappeared. In that rush of swirling black

water Commander King followed his ship. He had given his life that another might live!

It was for this reason that the secretary of the navy named a new destroyer the *Frank R. King*.

### DAY-DREAMS

BY CONSTANCE MACDOUGALL (AGE 13)

(Silver Badge)

DAY-DREAMS, day-dreams, castles in the air!  
Dreaming of the days to be without a thought of care!

Dreaming of a ship that sails upon a western sea,  
A ship that 's always sailing, a-sailing unto me.  
I'll have a castle great and tall upon a rocky crag,  
Above whose battlements shall float my emblem  
on a flag.

Below shall flow a river, majestic, wide, and deep;  
And round about, the snow-crowned hills their  
sleepless vigil keep.

Within the castle great and tall shall live a merry throng  
Of lords and ladies, who shall hold their feasts  
with jocund song.

And there 'll be tournaments in which the bravest  
knights take part;

In which the only weapons used shall be a Cupid's  
dart.

And in this land there 'll be no grief, nor sorrow;  
naught but mirth;

And every man shall have full share of all that he  
is worth.

And I 'll be lord of all this realm; its riches shall I  
win,

When sometime, in the days to be, my ship at  
last comes in.

### AN OCEAN ADVENTURE—A TRUE STORY

BY KATHARINE BURTON (AGE 14)

(Silver Badge)

WE have been going to Cape Cod for a number of years.

One afternoon (it was about the middle of summer), on the crowded beach, sat a nurse and a little boy three years old.

While his nurse sat chatting with a friend, the boy crawled down to the water's edge, where he saw a floating mattress a little way out. He thought it would be fun to get on it, so he crawled out into the water, unmindful of danger. When he tried to get on it, and finally succeeded, his weight made it move.

When he was some distance from shore, the nurse missed him. He was not in sight! Then she discovered him and she was terribly frightened. But she could not swim and could only shout for help.

There was no boat on the beach, so a man had to go to Hyannis, a town some distance away, to get a boat and rescue the child.

When they reached the little lad, he was near the edge of the mattress and was about to fall in the water. One of the men reached out quickly, picked the child up, and brought him safely aboard.

When they reached home, an anxious group awaited them on the porch of the house where the little sea-rover lived.

It is needless to say that the mother was deeply grateful to the people who had saved her child.



BY HENRY BUNTING, AGE 11  
(SILVER BADGE)



BY PHILLIPS L. BOYD, AGE 17  
(SILVER BADGE)



BY BILL HAYDEN, AGE 13  
(SILVER BADGE)

"MY FAVORITE NEGATIVE"

A STORY OF THE SEA

BY JESSIE SELLERS (AGE 15)

ONCE when Rudyard Kipling was quite a young boy, he was taken on a sea voyage by his father. Soon after the ship had got under way, Mr. Kipling went below, leaving his son with some sailors who were going to tell him stories and with whom he had begged to be allowed to stay.

When Mr. Kipling had been in his cabin about an hour, he heard a great commotion overhead, and one of the ship's officers rushed into his cabin, exclaiming:

"Your son has crawled out on the yard-arm, sir, and if he lets go, he will fall into the sea and be drowned!"

Mr. Kipling looked at the man very calmly, and replied:

"I suppose what you say is true, but if I know my son as well as I think a father should, I do not think he will let go."

With this, Mr. Kipling resumed his reading, while the exasperated officer gave him one look and tore up the stairs.

DAY-DREAMS

BY MOLLY BEVAN (AGE 17)

(Honor Member)

LYING half asleep in the waving meadow-grasses,  
Lulled by the song and the laughter of the  
stream,  
Some enchanting whisper in every wind that passes  
Speaks of things afar off and sets my heart a-  
dream!

Little fleecy clouds in the endless blue above me  
Are white ships sailing from some unknown  
shore—

White ships drifting with silver sails spread free,  
Weighted down with fairy gold and happy  
dreams of yore.

All summer long I dream amid the flowers,  
Golden dreams of long ago and ages yet to be!  
Perhaps the silver-cloud ships in some far-off  
happy hours,  
Will sail across the harbor and bring home my  
dreams to me!



BY TROWBRIDGE H. SWEET, AGE 10. (SILVER BADGE)



BY MABEL MEAD, AGE 17

"MY FAVORITE NEGATIVE"



A TRUE STORY OF THE SEA

BY HENRIETTA H. BRANNON (AGE 11)

WE sat in a pavilion on the sand, looking out over the ocean, on which sailed several steamers. Suddenly we heard a buzzing noise. Looking up, we saw a great biplane circling above us. It was close enough for us to see the pilot plainly. We watched the plane for some time as it circled about.

Then some one said, "There 's a hydro-plane!" Yes, there it was, dipping down into the water like a gull. It was very interesting to watch it with its boat-like contrivance hung below it. We soon forgot about the biplane.

Just then another great airship came into view. This time it was a dirigible, with a small car below it in which were several men. The sight we now saw was one never to be forgotten. The two planes were flying low over the water, the great balloon was floating through the air. Below them all, the steamers smoked peacefully on their way. The sight made us think of the many things which man has achieved.

DAY-DREAMS

BY MARGARET HUMPHREY (AGE 15)

(Honor Member)

WHERE the silver gleam of the rippling stream  
Glides into the forest dark,  
Where the brooklet sings, and the faint breeze  
brings

The lilt of a meadow-lark—

There I love to lie, watching clouds drift by,  
Building castles in the air,  
O'er a faerie sea, full of mystery,  
To a place that 's wondrous fair.

In a dainty boat I can gently float,  
Propelled by fancy's oars,  
To this land afar where the dream-folk are,  
With its shining, golden shores.

Here I wander slow through the long ago  
Where story-book people dwell.  
If I 'm good, perchance I may get a glance  
At the future!—Who can tell?



BY CONSTANCE CUMMINS, AGE 15



BY LOIS GILBERT, AGE 14. (SILVER BADGE)

BY HELEN JOHNSON, AGE 15. (GOLD BADGE. SILVER BADGE WON JUNE, 1920)

"AN OBJECT OF INTEREST"

There are flowers, too, of a brilliant hue,  
And birds that sing low and sweet;  
But I turn away, though I fain would stay,  
And back goes the faerie fleet.

To the world once more, to the brooklet's shore,  
Where is falling evening's chill;  
Day-dreams are gone, and the sun drops down  
Over the purple hill.

AN OCEAN ADVENTURE

(A True Story)

BY CAROLINE E. STAFFORD (AGE 12)

(Silver Badge)

DURING the War of 1812 my great-great-great-grandfather was commander of the privateer *Dolphin*.

The *Dolphin* at that time was sailing near Cape Saint Vincent, which is on the coast of Portugal, looking for English vessels which might prove valuable. On January 25, 1813, she suddenly sighted two ships in the distance, which, upon closer inspection proved to be two English merchant-vessels, the *Hebe* and a brig.

The men on board the *Dolphin* began immediately to prepare for a battle. Some loaded cannons, others cleared the deck of needless things, by either throwing them overboard or putting them in the cabin. Everybody, in anticipation of a battle, was astir doing something. At last when the English vessels were near, the *Dolphin* crept slowly between them, and suddenly fired the shot which began the engagement.

The battle raged for several hours, when the *Hebe* was forced to surrender, because her captain and eight men were wounded. The *Dolphin*, victorious, finally passed the British squadron in Chesapeake Bay and brought the two ships proudly into Baltimore. The enemy vessels proved to be richly laden and were very valuable prizes.

Captain Stafford treated his prisoners with great consideration, giving medical attention to the wounded and treating the others with kindness, landing them safely in Baltimore, with all their personal belongings intact.



BY DOROTHY HAGER, AGE 15

BY MARGARET M. HORTON, AGE 16  
(HONOR MEMBER)

BY HELEN BOWERMAN, AGE 15



BY HELEN MATHIS, AGE 13

BY ELEANOR WAYMAN, AGE 15  
(SILVER BADGE)

BY GEORGE BOWMAN, JR., AGE 13

## "MY FAVORITE NEGATIVE"

## DAY-DREAMS

BY ELIZABETH H. PARSONS (AGE 13)

*(Silver Badge)*

ALL the afternoon I lay  
 Dreaming, where the willows sway  
 Silvery, o'er the little stream  
 Where the golden pebbles gleam.

While the clouds above me sailed,  
 All the fields and woods were veiled  
 With the faint, green mist of spring;  
 Joy there was in everything.

As I saw each cloud flit by,  
 Downy white across the sky—  
 Dreams they seemed, day-dreams so shy  
 They only paused, smiled, and passed by.

## AN OCEAN ADVENTURE

BY ARTHUR C. WATSON (AGE 12)

*(Silver Badge)*

IN the year 1762 the *Laughing Lass* set out from Plymouth on a voyage to the Carolinas.

Among her passengers were two boys, Jack Munroe and John Stewart. Their families were going to settle in the town of Charleston.

One morning as the boys were sitting on the high poop-deck they heard a sailor cry, "Pirates on the port bow!" Sure enough! there was a ship flying the Jolly Roger.

The *Laughing Lass* was put about and all sail was ordered on, but the pirate vessel slowly drew alongside, and finally, the pirates fastened the two ships together with grappling-hooks.



Hardly had they done so when the sailors of the *Laughing Lass* delivered a volley that killed several pirates. Then the pirates boarded the ship and the fighting was hand to hand, the men using pikes and cutlasses.

Jack slid off the poop with the intention of helping the sailors, though he did not know exactly how, when he noticed that the pirate vessel was unguarded. Then an idea occurred to him. He sprang on to the pirate ship and quickly drew out his flint and steel and a box of tinder. To strike fire to the tinder and then to set the main cabin of the ship ablaze was a matter of a moment. Jack then jumped back to the *Laughing Lass*.

When the pirates found that their ship was on fire they leaped back to their own vessel. Then, while some of them fought the fire the others sailed the ship away.

During the rest of the voyage, which was uneventful, Jack was a hero.



"AN OBJECT OF INTEREST." BY HOWARD B. FRENCH, AGE 16  
(GOLD BADGE. SILVER BADGE WON AUGUST, 1921)

### DAY-DREAMS

BY ZAREPHA SALLUME (AGE 12)

(Silver Badge)

THE wind was fair, we sailed along,  
We heard the lilt of far-off song,  
The lilt of song so wild and sweet,  
That sounded light as fairy feet;

We sailed along o'er sparkling seas.  
Our sails were playing with the breeze.  
We laughed, as mermaids rose to sip  
The nectar from the lily's lip.

We sailed along until, at last,  
The Isle of Golden Dreams we passed;  
An isle where sun shines all the day,  
Whence summer never goes away.

A land where crystal fountains fall  
Against the towering castle wall;  
A land where roses, fresh in bloom,  
Burden the air with faint perfume;

And lakes, with lilies blooming free,  
That in their fairness smiled at me.  
We passed it by, that island fair,  
Its beauty vanished into air.

These longing fancies came to me,  
While watching ships sail out to sea.  
*Day-Dream* had called, I could not stay,  
And in her bark I'd sailed away!



"MY FAVORITE NEGATIVE." BY KATHERINE ROSS, AGE 11

### DAY-DREAMS

BY PATSY KELLEY (AGE 15)

(Silver Badge)

WHEN the beach was still and lonely,  
And the waves, so wild and free,  
Turned to restless ripples only,  
And the sunset lit the sea,

When each ripple glistened under  
Countless rays of rosy light,  
Then my soul grew great with wonder  
At the beauty of the sight.

And I dreamed of coming ages,  
Days when man would glorious be;  
Struggling upward, through the pages  
Of a grand eternity.

As I stood, with fancy roving,  
Storm-clouds stole across the sun;  
And the pine tops, restless, moving,  
Told of wrongs already done.

Then the world grew bleak and dreary.  
Fruitless, then, my fancies seem.  
Yet, at times, in doubt, I query:  
"Was it nothing but a dream?"

### SPECIAL MENTION

A list of those whose work would have been used had space permitted:

PROSE		VERSE	
Virginia Cunningham	Margaret Coleman	Lucille Breeding	June Whitney
Virginia Farrington	Lucille Breeding	Jane Prather	Margaret B. Oleson
Elizabeth McCullough	Winfred Storrs	Louise J. Quartes	Eleanor Jones
Oscar Handley, Jr.	Katharine W. Patton	Katharine W. Patton	Elinor Cobb
Margaret Williams	Margaret Atkins	Margaret Atkins	Rosalind Leale
Minnie Pfejferberg	Bertha Kennedy	Marion Jackson	Elizabeth Shaw
Clarence Peterson	George Wadleigh	Marjorie Dow	Nancy Hodgkin
Katharine H. Collins	Marjorie Dow	Luna Bard	Jeanette Thurston
Reginald J. Stanley	Luna Bard		Alice H. Frank
Betty Fry			Tillie Weinstein
Esther R. G rton			Evelyn Crow
Margaret Durick			Edward B. Black
Julia F. V. Veer			Dorcas E. Gallaher
Harriet Arnold			Elizabeth Brooks
Elizabeth Clarke			Beatrice Wadhams
Elizabeth Pomeroy			Madelon Burbeck
Moffatt			Sumner Benson
Jean Alton			Jane Hemingway
Elizabeth E. Hughes			Helen Louise
Lois Mills			Whitehouse
Shirley White			John Brewster Korn
Emily L. Brandt			Charlotte Elizabeth
Lorothy M. Jones			Varquhar
			Marion H. Turner
			Evelyn Evans
			Ann Sommerich
			Mary C. Reynolds
			Margaret Griffith
			Elizabeth Brainerd
			Henry Collins
			Phyllis Hodges

**DRAWINGS**

Marian Rogers  
Kathryn Schultz  
Margaret Westoby  
Elsie M. Falk  
Lois A. R. Lord  
W. Clark Hanna  
Lyle McIntire  
Elizabeth Field  
Lloyd Schultz  
Elizabeth Runble  
Helen E. Toennies  
Grace Herman  
Alice Ross Bennett  
Marian E. Frisbie  
Donald Mulvihill  
Sarah K. Stafford

Katharine Atkins  
Vincent Jenkins  
Benjamin C. Bowen  
Anna O. Todd  
Constance Cummins

**PHOTOGRAPHS**

Frances E. Robbins  
Marian B. Simonds  
Edith Callaghan  
Estelle E. Smith  
Sara Miller  
Ruth Lawrence  
Frances L. Edgerton  
Alice Seney  
Hazel Seligman  
Geraldine Droppers

Evelyn Horner  
Thankful Cornwall  
Virginia Thomas  
Laura B. Pierson  
Mary Scattergood  
Elizabeth Farthing  
James C. Perkins  
Isobel Bevan  
Gladys Duffy  
Virginia H. Miley  
Irma Harbeck  
Margaret Reynolds  
Constance Cartwell  
Christine Holland  
Josephine R. Howell  
Louise Abernathy  
Payton Kelly

**WHAT THE LEAGUE IS**

THE ST. NICHOLAS LEAGUE is an organization of the readers of the ST. NICHOLAS MAGAZINE.

THE LEAGUE motto is "Live to learn and learn to live."

THE LEAGUE emblem is the "Stars and Stripes."

THE LEAGUE membership button bears the LEAGUE name and emblem.

THE ST. NICHOLAS LEAGUE organized in November, 1899, became immediately popular with earnest and enlightened young folks, and now is widely recognized as one of the great artistic educational factors in the life of American boys and girls.

THE ST. NICHOLAS LEAGUE awards gold and silver badges each month for the best original poems, stories, drawings, photographs, puzzles, and puzzle answers.

**ROLL OF HONOR**

A list of those whose contributions were deserving of high praise:

**PROSE**

Virginia Stratton  
Jean M. Snell  
Dorothea Tucker  
Sylvia Allerhand  
Betty Dow  
Elizabeth U. Powell  
Mary Marum  
Martha McCowen  
Marjorie Meyer  
Louise Poreh  
Merrill Jones  
Mary Bryan  
Ruth B. Lyman  
George Corsun  
Ruth Wilkinson  
Maria Fletcher  
Beatrice Beach  
Dorothy Jenkins  
Frances Wilson  
Dorothy Horton  
Eugenia Coleman  
Isabel M. Burtis  
Monica Marie

**PHOTOGRAPHS**

Maxine Wiley  
Helen March Duer  
Elizabeth McSwain  
Eveline  
Cohn-Merlin  
Charlotte L.  
Groom  
Katherine Dines  
Marucci Capuzzi  
Virginia Hickok  
Jane Lee  
Catharine P.  
Turner  
Sara M. Foster  
Jacqueline Walther  
Jean Paton  
Josephine Steckel  
Caroline Sneed  
Edythe E. Cook  
Annie Gilllette  
Amelia Bachman  
Mary McR. Neale

**PHOTOGRAPHS**

Frances Kimball  
Frances L. Flagg  
Barbara Taylor  
Catherine Watson  
Elizabeth Greenleaf  
John Franks  
Minnie Bresovsky  
Elizabeth W.  
Tenney  
Dorothy D.  
Talman  
Blanche H.  
Gaillard  
Emily B. Learned  
Alice D. Love  
Helen H. Loeffler  
Mary McKenrick  
Harriet Dow  
Alpa Whitney  
Hildegarde  
Lehmann  
Adelaide M.  
Barton  
Martha Duncan  
Elinor Kendall  
Ruth H. Rowley  
Ruth Ropes  
Elisabeth Perkins  
Eloise Andrews  
Clare Andrews  
Dorothy Gaehr  
Cathella Wright  
Helen Ireland  
Maria Luisa de la  
Torriente

**DRAWINGS**

Haller  
Christine Cameron  
Elizabeth Norton  
Nellie F. Nickell  
Nancy Millett  
Janet Ross  
Sabra Frances  
Rollins  
Alethea Hanson  
John N. Brownrigg  
Walter Kealy  
Elizabeth D. Boies  
Jane Dick Meyer  
Rose Terry Niles  
Durward Stokes  
Nina Lowenstein  
Alice Winston  
Florence King  
Rose Pollack

Jean McKenna  
Janet D. Atwater  
Ellen L. Carpenter  
Elease Weins  
Virginia Quarles  
Betsy Spadone  
Lois Stephens  
Aretha Ferris  
Sylvester  
Gatewood  
Muriel F. Doe  
Walton Christian  
Lalia B. Simson  
Dorothy Dayton  
Mary Hitechock  
Welde  
Margaret Haley  
Marjorie E.  
Stephens

**PUZZLES**

Alma Miller  
Eleanor Thomas  
Virgil Lule, Jr.  
Doris Goldberg  
Ruth R. Rhinock

**PRIZE COMPETITION, No. 273**

**Competition No. 273** will close September 1. All contributions intended for it must be mailed on or before that date. Prize announcements will be made and the selected contributions published in ST. NICHOLAS for December. Badges sent one month later.

**Verse.** To contain not more than twenty-four lines. Subject, "The Wondrous Star."

**Prose.** Essay or story of not more than three hundred words. Subject, "A Christmas Surprise."

**Photograph.** Any size, mounted or unmounted; no blue prints or negatives. Young photographers need not develop and print their pictures themselves. Subject, "In Winter-time."

**Drawing.** India ink, very black writing-ink, or wash. Subject, "Getting Ready," or "A Heading for December."

**Puzzle.** Must be accompanied by answer in full. **Puzzle Answers.** Best and neatest complete set of answers to puzzles in this issue of ST. NICHOLAS. Must be addressed to THE RIDDLE-BOX.

No unused contribution can be returned unless it is accompanied by a self-addressed and stamped envelop of proper size to hold the manuscript or picture.

**RULES**

ANY reader of ST. NICHOLAS, whether a subscriber or not, is entitled to League membership, and upon application a League badge and leaflet will be sent free. No League member who has reached the age of eighteen years may compete.

Every contribution, of whatever kind, must bear the name, age, and address of the sender and be indorsed as "original" by parent, teacher, or guardian, who must be convinced beyond doubt—and must state in writing—that the contribution is not copied, but wholly the work and idea of the sender.

If prose, the number of words should also be added. These notes must not be on a separate sheet, but on the contribution itself—if manuscript, on the upper margin; if a picture, on the margin or back. Write in ink on one side of the paper only. A contributor may send but one contribution a month—not one of each kind, but one only; this, however, does not include "competitions" in the advertising pages or "Answers to Puzzles."

Address: **The St. Nicholas League,**  
The Century Co.  
353 Fourth Avenue, New York.

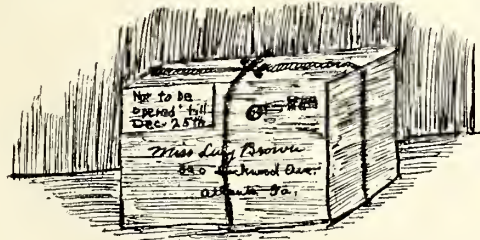

"AN OBJECT OF INTEREST." BY ELIZABETH FLINN, AGE 13 (SILVER BADGE)

**VERSE**

Evelyn Frost  
Nancy Hayward  
Eleanor Huntley  
Florence S. Young  
Virginia Dewey  
Elizabeth Dargan  
Phebe Lemon  
M. Willard Messler

Harriet L. Jones  
Dorothy Yeager  
Mariette E. Paine  
Jennette Terry  
Anne Meux  
Sallie C. McKenzie  
Anna C. Mudge  
Myra A. Sobel  
Jean Alice Gall

Leslie Friend  
Dorothy Ballin  
Frances D. Clark  
Benjamin F. Brown  
Margaret Waite  
Edith N. Cook  
Norma V. Stemm



# THE LETTER-BOX

LIMA, PERU.

DEAR ST. NICHOLAS: I enjoy your magazine very much. In the March number, there is a letter from Margaret Creelman, a cousin of mine, and my father used to read the same ST. NICHOLASES she tells about.

I have traveled a great deal for my age. I am now in Peru, a very interesting place. There is one city most wonderful of all—the old Inca capital of Cuzco. Mostly Indians live there and they dress so very queerly. They wear big flat hats and long skirts, and shawls of the most brilliant colors you ever saw—yellow, green, red, blue, and every color possible. Their skirts also are of different colors, but not mixed. All the streets are paved with cobbles, and it is very unpleasant to walk on. When you go to Cuzco you have to take a ship to Mollendo, and the ship stops a long way from shore. You have to go ashore in a launch, and when you get to shore there is a very high wall and you have to be taken up in a chair. It seems very funny, but sometimes, if the launch is not quite ready or if it is very rough, you swing about in the chair, and it seems as if you were going to be put in the sea instead of the launch. The trip in the train from Mollendo to Cuzco is very interesting. The train goes up and up until it gets to a height of 14,666 feet above sea-level, the highest point on that railroad, and then it goes down again, for Cuzco is only 11,000 or 12,000 feet.

I go to an English school, but I speak Spanish most of the time. I have no brothers or sisters, but I have lots of friends.

Your loving reader,  
ELISABETH DURHAM (AGE 10).

NASHVILLE, TENN.

DEAR ST. NICHOLAS: Although I have only taken you for six months, I have enjoyed you so much. The month of May I spent in the West. When I was at the Grand Cañon we took some sight-seeing trips. We went over to Hermit's Rest. I wanted my picture taken there, overlooking the Cañon. I had my ST. NICHOLAS in my hand, and I turned it around, so every one could see the title. Then I had my picture taken that way.

Your delighted reader,  
EVA STEVENS (AGE 11).

GRAND RAPIDS, MICH.

DEAR ST. NICHOLAS: I have taken you for several years, and have certainly enjoyed every one of your numbers.

My eldest brother is sixteen years old and he thinks himself quite dignified, but his dignity flees when he races with me to the mail-box to get you first.

I have several girl friends who enjoy you as well as I do, and when you are about due at my home they all call me over the telephone and ask if you have arrived. If you have, we all set a date to meet, so that we can read your stories together. I should like to join the LEAGUE very much.

With love, I remain your devoted reader,  
CAROLINE LEWIS (AGE 14).

WATERBURY, CONN.

DEAR ST. NICHOLAS: I have taken you for two years, and love you better every minute. I think you are the best magazine in the world, and so do my mother and father and younger brother.

I do love the LEAGUE and THE LETTER-BOX so much. I always save them for the last, so that I may enjoy them for a long time. Then, after I've read the whole magazine through once, I'll start back at the beginning again and read it all over several times.

I shall take you as long as I possibly can, and I always tell my friends about you, so they all love you too. A great many of them take you.

Best luck to you, dearest magazine in the world,  
Your affectionate reader,

LAURA PIERSON (AGE 14).

ROME, ITALY.

DEAR ST. NICHOLAS: I have taken you for two years and expect to take you for many more to come. My mother took you when she was a little girl.

You have followed me to France, Egypt, up the Nile, through Palestine and Syria to Constantinople, to Greece and back to Italy. I am taking care of a little Syrian girl in Nazareth and will send her ST. NICHOLAS as soon as she can read enough English. I think you are the nicest, best, most interesting magazine in all the world.

Your loving reader,  
BARBARA BEACH THOMPSON (AGE 12).

ZAMBOANGA, MINDANAO, P. I.

DEAR ST. NICHOLAS: I am a little girl, ten years old. I was born in Zamboanga and I have lived here ever since, with the exception of a few years which I spent in Japan, China, and the United States.

General Wood has visited Zamboanga two times and I have been introduced to him.

Mother saved the numbers of ST. NICHOLAS she got when she was a little girl. I like you very much and can hardly wait for the next one to come.

Your true reader,  
KATSY JURIKA (AGE 10).

ALLENWOOD, N. J.

DEAR ST. NICHOLAS: I have taken you for almost two years, and I like you very much. I like "The Blue Envelop," "The Turner Twins," and "The Hill of Adventure" very much.

I think you would like to hear about my home. I live in the country. It is very nice here in summer. We have three big geese and three little geese. Their names are Jimmie, Jack, Pete, Danny, Jake, and Moses. We have fifty big chickens and ten little chickens. We have two big cats, two little kittens, and a Maltese poodle.

I remain, your loving reader,  
WILLIAM W. COWARD (AGE 11).

PRINCETON, N. J.

DEAR ST. NICHOLAS: You are the best magazine I have taken. Nearly every boy I know takes you, and likes you very much.

Your devoted reader,  
DOUGLAS STUART (AGE 9).

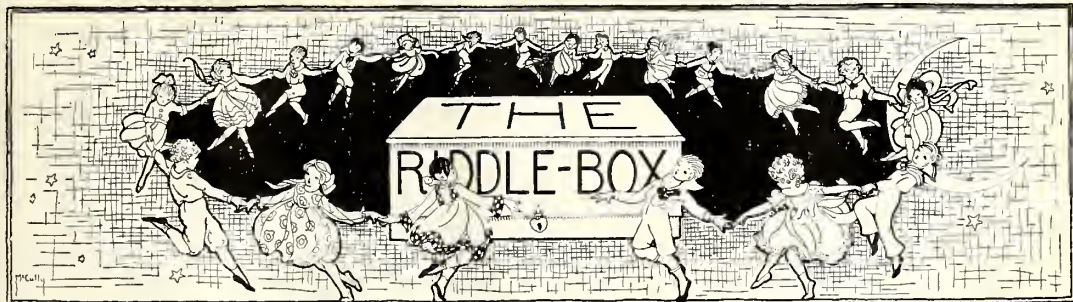

## ANSWERS TO PUZZLES IN THE JULY NUMBER

**A FRENCH ACROSTIC.** Initials, The Three Musketeers. From 1 to 5, Dumas; 6 to 14, D'Artagnan; 15 to 19, Athos; 20 to 26, Porthos; 27 to 32, Aramis; 33 to 41, Constance; 42 to 47, Milady; 48 to 55, Planchet; 56 to 68, Anne of Austria. Cross-words: 1. Traduee. 2. Hassock. 3. Earnest. 4. Tragedy. 5. Har-ness. 6. Respect. 7. Educate. 8. Egotism. 9. Maneale. 10. Uniform. 11. Seminal. 12. Kitchen. 13. Ethical. 14. Theater. 15. Erratum. 16. Espouse. 17. Rostrum. 18. Salient.

**DIAMOND.** 1. M. 2. Baa. 3. March. 4. Ace. 5. H. **OBLIQUE PUZZLE.** 1. P. 2. Ham. 3. Paced. 4. Meter. 5. Defer. 6. Redan. 7. Rages. 8. Nests. 9. Stout. 10. Surer. 11. Tenet. 12. Relay. 13. Talon. 14. Yodel. 15. New. 16. L.

**NOVEL ACROSTIC.** Primals, Napoleon; third row, Waterloo. Cross-words: 1. Newly. 2. Alarm. 3. Petal. 4. Opera. 5. Large. 6. Ellen. 7. Ozone. 8. Noose.

**TO OUR PUZZLERS:** To be acknowledged in the magazine, answers must be mailed not later than August 27 and should be addressed to St. Nicholas Riddle-Box, care of The Century Co., 353 Fourth Avenue, New York City, N. Y. Solvers wishing to compete for prizes must comply with the LEAGUE rules (see page 1117) and give answers *in full*, following the plan of those printed above.

**ANSWERS TO ALL THE PUZZLES IN THE MAY NUMBER** were duly received from Elizabeth Tong—Arthur Knox—John F. Davis—"The Three R's"—"The Days."

**ANSWERS TO PUZZLES IN THE MAY NUMBER** were duly received from I. R., 11—Kemper Hall Chapter, 11—John R. Hopkins, 9—Carlan S. Messler, 9—M. Willard Messler, 8—Gertrude R. Jasper, 5—Elizabeth S. Livermore, 5—Gertrude and Margaret, 5—Roman Kopee, 5—Gerard G. Cameron, 4—Yvonne G. Cameron, 4—Elizabeth Field, 3—Elizabeth Brooks, 3—Jean D. Noyes, 3—"E. Authors," 3—"Blaekie," 3—Ruth V. Skinner, 2—No name, III, 2—Kingsley Kahler, 2—Elizabeth Keith, 2—Marjorie Hoar, 2—Constance Lewis, 2—Jane R. Leopold, 2—Helen E. Haven, 2—Elizabeth Hawes, 2—Valerie Tower, 2—Charles Stanley, 2. One puzzle, E. T. Blossom—J. M. Sprague—E. Fahnstock—M. North—R. P. Lane—J. Rankin—M. M. Robinson—D. White—G. Grant—M. Mattis—H. Reeves—N. Wolff—K. Gregory—D. Jones—A. Koop—D. Gachr—I. L. Thro—H. L. Dorsey—S. Wildman—E. J. Bowman—J. Wesneski—H. Bergstresser—L. L. Evans—K. E. O'Connor—K. Kerlin—K. Higbee—R. Wilmot—O. Gassaway—N. Robinson—F. Vladimir—B. Duval, 1—M. Cowan—E. Rodenbaugh—D. Eggleston—D. G. Meyer—D. McWethy—A. Andrews.

### A POET'S PUZZLE

(Silver Badge, St. NICHOLAS LEAGUE  
Competition)

. . 14	. . 10	CROSS-WORDS: 1. The
2 . . . . .	5 . . . . .	father of the Roman gods.
. 7 . . . . .	16 19 17 . .	2. An epic poem attribut-
. . . . .	11 . . . . .	ed to Homer. 3. A Ro-
. . . . .	-1 . 21 25 . .	man emperor who built a
. 6 9 . . . . .	. . . . .	wall in Britain. 4. A
22 . . . . .	. . . . .	famous cataract. 5. The
. . . . .	23 . . 8 4 . .	most famous murderer in
13 . 18 . . . . .	. . . . .	all literature. 6. A name
. . . . .	3 . 24 . 20 . .	anciently given to a re-

gion on the western coast of the Balkan peninsula. 7. A native of a certain part of northern Italy. 8. The lover of Cressida. 9. The father of Antigone. 10. The goddess of vengeful justice.

When these names have been rightly guessed, the initial letters, reading downward, will spell the name of a famous poet. The letters indicated by the numbers from 1 to 5, from 6 to 13, and from 14 to 25 each name one of his poems.

ISABELLE ROBERT (age 16).

### DOUBLE DIAGONAL

All the words described contain the same number of letters. When rightly guessed and written one below another, the diagonals (from the left-

hand upper letter to the right-hand lower letter, and from the right-hand upper letter to the lower left-hand letter) will each spell the surname of a President.

**CROSS-WORDS:** 1. In flight. 2. To honor reverently. 3. To set at defiance. 4. A foe. 5. Sets of players in a game.

CARLTON B. GUILD (age 10), *League Member*.

### NUMERICAL ENIGMA

I am composed of thirty-nine letters and form a quotation, counseling prudent speech, from Haslitt.

My 7-23-36-30 is to care for. My 33-10-12-18 is an air sung by a single person. My 5-3-29-39 is a famous river. My 14-38-37-1 is a masculine name. My 13-32-20-27 is to desire. My 22-35-11-9 is a part of certain large animals. My 4-21-15-26-17 is to faint. My 34-28-6-25-31 is a kind of powder. My 19-8-16-2-24 is to rouse from sleep.

V. DAVIS.

### A CLASSICAL CROSS-WORD ENIGMA

My first is in Naples, but not in Rome;  
My second, in Rome, but not in Sparta;  
My third is in Sparta, but not in Phœnicia;  
My fourth is in Phœnicia, but not in Greece.

My whole was a cruel Roman.

VIRGINIA NEWCOMER (age 13), *League Member*.





In this puzzle the words are pictured instead of described. When the eight objects have been rightly named and written one below another, the central letters, reading downward, will spell a mountain, famous many years ago.

**CHARADE**

My *first* is man's support and stay;  
It aids his toil, it helps him pray:  
My *next* you see when seeing me:  
My *third* no man could hope to be.  
My *two* and *one*, as you'll recall,  
Appeared in writing on a wall,  
And none could fly from its decree,  
Because it was my *whole*, you see.

HESTER A. HOPKINS.

**TRANSPOSITIONS**

My *whole*, consisting of six letters, means a conflict. My first three letters may be so placed as to form a word meaning small flap; my last three letters may be so placed as to form a word meaning to permit. Together, these two words mean a flat object on which to write.

EUGENIA LEIGH (age 10), *League Member*.

**WORD-SQUARE**

1. One who goes by. 2. On fire. 3. Covered with slates. 4. Keeness and severity of remark. 5. To come forth from concealment. 6. To make amends for.

B. NEWMAN.

**GEOGRAPHICAL ZIGZAG**

All the words described contain the same number of letters. When rightly guessed and written one below another, the zigzag (beginning at the upper, right-hand letter and ending with the lower, left-hand letter) will spell a message sent by the son of a famous man to his brother.

**CROSS-WORDS.** 1. A sound in the state of Washington. 2. One of the United States. 3. A famous city and province of Belgium. 4. The "river of silver" between Uruguay and the Argentine Republic. 5. A country of Europe famous for its art. 6. The chief river of Russia. 7. A seaport of northern Africa. 8. A seaport situated on All Saints' Bay. 9. An arm of the

Atlantic near Greenland. 10. A large city of England. 11. An island connected with legends of Zeus and Minos. 12. The cape at the southernmost point of the United States. 13. A seaport in Kent, England.

MARY V. FULTON (age 14), *League Member*.

**DIAMOND**

1. In June. 2. Color. 3. A magistrate. 4. To incite. 5. In June.

G. R. H.

**KING'S MOVE PUZZLE**

1	2	3	4	5	6	7	8
T	B	B	A	T	N	A	M
9	10	11	12	13	14	15	16
O	T	E	H	H	T	I	S
17	18	19	20	21	22	23	24
R	O	A	T	I	E	A	L
25	26	27	28	29	30	31	32
M	D	L	T	Y	O	R	E
33	34	35	36	37	38	39	40
L	O	R	P	F	T	O	B
41	42	43	44	45	46	47	48
S	I	A	R	L	L	C	R
49	50	51	52	53	54	55	56
I	A	T	O	N	E	O	T
57	58	59	60	61	62	63	64
S	N	N	A	S	W	U	N

Begin at a certain square and move to an adjoining square (as in the king's move in chess) until each square has been entered once. When the moves have been made correctly, the names of five famous books may be spelled out. The initials of these five names will spell the name of the author. The path from one letter to another is continuous.

ELIZABETH GREENLEES (age 14), *League Member*.

# Beech-Nut Peanut Butter



**B**READ spread thick with Beech-Nut Peanut Butter—what reg'lar feller wouldn't sink his teeth in such a tidbit? After a good swim or a hot, dusty ball game, when your appetite is just fairly hollering out, *that's* when you want a slice—or two, or *three!*

How it does satisfy hunger—that rich, mealy, tasty peanut delight! And *good* for you, too. Each jar is fresh, sealed to keep in that famous Beech-Nut flavor. At most grocers.

BEECH-NUT PACKING COMPANY

*"Foods of Finest Flavor"*

Canajoharie

New York





# PAUL JONES GARMENTS



## The Charm of Simplicity

Natural color—natural clothes. These are the things that *nearly everyone* admires. "Paul Jones Garments are *truly beautiful*," writes a mother. Planned by the designers of the *very first girl's middy*. Paul Jones Garments are warranted without reserve and can be bought for as low as \$2.00.

You can get them at the good store in your city, or write us for the name of the dealer near you.

Helpful suggestions for Schoolwear and Sports use are in the interesting Paul Jones Style Book. Write for it. Address Dept. A-5.

# PAUL JONES GARMENTS

MORRIS & CO., Inc., Baltimore, Md.  
"Quality First"



## BOYS, YOU CAN MAKE BIG MONEY

selling THE BOYS' MAGAZINE each month. Write us today for 5 copies. *Send no money.* Address

THE SCOTT F. REDFIELD CO., Inc.  
7270 Main St. Smethport, Pa.

Every Youngster Needs and Wants This



**SCHOOL BAG, 50c**  
Strong and durable. Holds 4 books. These are army hand grenade bags, extra strong, with heavy canvas adjustable shoulder straps. All new. Start your kiddies' school year with one of them.

W. STOKES KIRK, Dept. 83,  
1627 N. 10th St., Philadelphia, Pa.



# TALES OF TRUE KNIGHTS

By

## George Philip Krapp

SIXTEEN of the best old tales, mainly from the Middle Ages, of faëry and chivalry and folk lore, beautifully retold by a Professor of English in Columbia University. He has given them a background, too—not a pedantic or dry one, but such as will give young readers an intelligent appreciation of how these old legendary stories grew out of the narratives of wandering minstrels and patient chroniclers. Some of them are: Sir Cleges; King Horn; Havelock the Dane; Adam Bell, Clim of the Clough and William of Cloudesley; Werwolf; and Gargouille and Romaine.

*Beautifully illustrated*

**\$1.75**

*At All Booksellers, or*

## THE CENTURY CO.

353 Fourth Avenue

New York City

# Feels good and prevents infection!

An after-shaving application of diluted Absorbine, Jr. leaves the skin cool, soothed and refreshed. It is the liniment with the clean, pleasant odor.

It is an effective antiseptic for razor cuts and scratches. It is cleansing, healing and prevents infection.

Its germicidal properties are excellent for conditions of sore throat; used regularly as a gargle it destroys germs that otherwise may cause serious trouble.

After brushing the teeth, use Absorbine, Jr. as a mouth wash. It keeps the mouth and breath sweet and clean; and destroys crevice hidden germs that cause decay.

This guardian of health is obtained at most druggist's, \$1.25, or postpaid. A liberal trial bottle, 10c, postpaid.

**Absorbine Jr.**  
THE ANTISEPTIC LINIMENT

W. F. YOUNG, Inc.  
360 Temple St., Springfield, Mass.

as a mouthwash



as a gargle

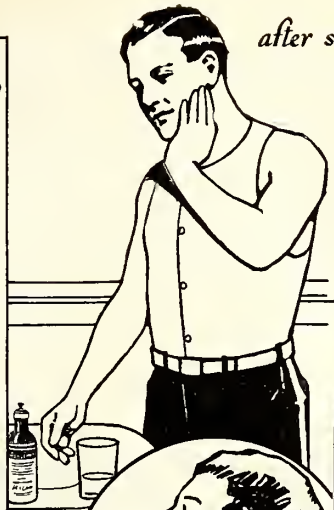

after shaving



**Moore Push-Pins**  
Glass Heads - Steel Points  
**Moore Push-less Hangers**  
To hang up things  
Ask your dealer to show them  
Sold Everywhere **10¢** per packet  
**Moore Push-Pin Co.**  
Wayne Junction Philadelphia

**KOKOMO SKATES**  
Are Young America's First Choice  
Ask your dealer for them.

**KOKOMO STAMPED METAL CO.**  
Kokomo, Indiana

## Reliability

is the key-word of the ST. NICHOLAS advertisements.  
You can also count on the quality of goods advertised in these pages.

## Ride A Ranger

The finest bicycle ever built. 44 Styles, colors, sizes; made in our new factory. SAVE \$10 to \$25 by direct from the factory purchase.  
Delivered free on approval, express prepaid, for 30 Days' Free Trial. 12 MONTHS to PAY, if desired.  
Tires best quality at factory prices, express paid. Lamps, wheels, horns, equipment and repairs at unusually low prices. Send No Money, do business direct with makers.  
Write today for free Ranger Catalog, factory prices and marvelous easy payment terms.

**Mead Cycle Company**  
Dept. A15 Chicago



# ST. NICHOLAS STAMP PAGE

CONDUCTED BY SAMUEL R. SIMMONS

## NEW ISSUES

AUSTRIA is very busy these days issuing new stamps. Probably they are needed, not for postal uses so much as to replenish the empty treasury by sundry sums extracted from the pockets of stamp-collectors. Yet, on the other hand, we learn that this country is to discontinue the issuance of newspaper stamps, of which there has been a long series. These stamps have always been low priced in the catalogue and therefore popular with the beginner and young collector, whose funds, alas! are limited. We picture two types of one of the later issues of Austria. Note how, with the depreciation of the krona, the face value of the set increases. We picture the

hand loom. The 5 M, red in color, has the picture of a blacksmith working at his forge. He is evidently much in earnest, his right arm raised with a striking hammer in his hand, while in his left hand are tongs which hold upon the anvil a piece of presumably red-hot metal.

## AIR MAIL

ONE of the greatest fascinations about stamp-collecting is to be found in its everbroadening scope. Its devotees are never permitted to lose interest. The fascinating game leaps forward continually to new phases. To the beginner, there is the interest of a general collection; he collects stamps from all over the world, no matter



15 and the 45 krona. Whether or not these ornamental central designs have some meaning, we do not know.

Lithuania sends us a set of new stamps. Two of these represent agricultural industries—the 20 Skatikū, blue in color, represents a man sowing grain. The solid background of color, the rising sun, reminds us strongly of the sower upon certain stamps of France. Yet the design really is entirely different. The 50 sk., brown, is not so forceful a stamp—the design has too much margin; it crowds the central picture of the reaper sharpening his scythe. The balance of the set are like the 40 sk., red, except that the higher values are in two colors, which make them very striking in appearance. Under the crowned portrait in the center is the word “Kestutis,” which we presume is his name. Can any of our readers tell us more about him? The whole set is printed upon a peculiar paper, very thin, and watermarked with a honeycomb design.

We also picture two stamps from a new series from Esthonia. The stamps are rather interesting in design, but the workmanship is so poor that it kills whatever of excellence there may have been in the original drawing. The 2M is green in color. The design at the top represents a woman working at what we presume is an old-fashioned

from what country. He even at times regrets his inability to acquire for his collection the stamps—if there are any—which are used in the moon, or in Mars and the other planets. His aim is primarily quantity, and the more stamps he acquires the better pleased he is. Beyond the beginner comes the specialist, the man who confines his collecting to the stamps of one nation,—or perhaps one issue, or specimens of a single stamp,—but who seeks completeness in his chosen line. He wants all minor varieties, all shades, plate-marks, and imprints, everything, in fact, which serves to increase his knowledge concerning his chosen field. He often carries this search on beyond the mere stamp into the field of cancellations. He will rejoice over a “red bar” or “blue bar” or “black bar” cancellation in his stamps of the 1847 issue of the United States. A “town cancellation,” or a stamp postmarked with the famous “kicking mule,” is a joy to his soul. It is of no use for the general collector to argue with the specialist that “minor varieties” are but as fly-specks on the plate, or to try to insist that “cancellations” are not stamps. All is in vain, and the specialist goes gleefully on his destined and chosen way. But each specialist does at least succeed in this: he widens the field of knowledge, and broadens stamp-collecting by opening a new phase of it—a new outlet for the restless energy of those who will not follow in the beaten track laid out by the vacant spaces in the printed album.

There has recently come to us the first issue of a new paper, a philatelic publication called “Air Mail,” published by Eugene Klein, the well-known stamp-dealer of Philadelphia. Think of it! A stamp paper devoted primarily just to those who collect the stamps that are issued only

(Concluded on second page following)

## THE ST. NICHOLAS STAMP DIRECTORY

is really a list of reliable Stamp Dealers. These people have studied stamps for years, perhaps they helped your father and mother when they first started their stamp collections. *St. Nicholas* knows that these dealers are trustworthy. When writing to them be sure to give your full name and address, and as reference the name of your parent, or teacher, or employer, whose permission must be obtained first. It is well also to mention *St. Nicholas Magazine*. Remember, we are always glad to assist you, so write to us for any information that will help you solve your stamp problems.



### TRIANGLE

Scarce FIUME (like illustration), also 50 other different stamps, China ship set, large \$1.00 U. S. revenue; millimetre scale, ruler and All For perforation gauge. Bargain lists and 50 to 60% approvals with every order. **FENNEL STAMP CO.** 9c  
Dept. S. Fullerton Bldg., St. Louis, Mo.

**STAMPS** 50 different Jamaica, Venezuela, etc., only 7c; 100 all different, 10c; 1000 all different, \$2.50; 100 different U. S. 25c; 1000 hinges, 10c; 50% approvals with every order. List Free. I buy stamps.

L. B. DOVER Dept. F. Longmont, Colo.

### BARGAINS EACH SET 5 CENTS

4 Iceland; 8 Finland; 20 Sweden; 8 Honduras; 8 Costa Rica; 10 Russia; 8 Dutch Indies; 4 Siam. Lists of 7000 low-priced stamps free.  
CHAMBERS STAMP CO., 111 G NASSAU STREET, NEW YORK CITY

### FREE

Packet of desirable stamps, exceptional quality to approval applicants furnishing satisfactory references.

H. C. ARGENBRIGHT, Box 352, Staunton, Va.

**80 STAMPS** 14c; Indore, Morocco, Trinidad, Georgia, Mozambique, etc. 100 diff. 12c; 500 do. 90c; 100 War 24c; 200 do. 50c; 20 Siam 36c; 50 Austria 18c; 50 Hungary 18c; 50 Colonials 18c.  
BROOKS, 43 Edmund St., Cambewell, Eng.

### FREE

10 Scandinavian, millimetre scale, gauge, book, lists, etc., to all sending 10c for 57 diff. Siam, Ceylon, Guatemala, etc., 200 diff. 25c, 300 diff. 75c., 100 diff. U. S. 25c.

HAWKEYE STAMP Co., Cedar Rapids, 49, Iowa.

### FREE

20 Diff. British Colonies for a request for my 1, 2, 1 and 2c approvals also the higher priced stamps at 50% Disct. with extra Discts. for prompt returns.

CHARLES T. EGNER, 1335 Pike St., Philadelphia, Pa.

## EVER TRIED US?

10c From **WHY NOT?** Good Stamps  
First Lot Free **APPROVALS** Fair Prices  
**MANLIUS STAMP CO.** MANLIUS, N. Y.

### WORLD'S LARGEST Wholesale and Retail Catalogue of Postage Stamps now ready. 128 pages.

Single stamps, sets, packets, albums, mixtures, supplies, etc.

**Price 10 cents. Worth \$5 to you. Send 10 cents today.**

**Bargain Sets** We offer these great bargains at low prices. No two stamps alike in any set. All fine. 50 Africa 24c; 15

Arg. Rep. 11c; 50 Asia 17c; 35 Austria 10c; 35 Bavaria 20c; 10 Brazil 5c; 100 Br. Col's 23c; 25 Bulgaria 25c; 20 Chile 11c; 10 China 7c; 50 Cuba 49c; 10 Czecho's 12c; 10 Egypt 7c; 7 Iceland 20c; 50 Italy 19c; 40 Japan 7c; 8 Liberia 25c; 17 Mexico 10c; 13 Nyassa 45c; 10 Paraguay 10c; 25 Persia 25c; 6 Reunion 5c; 20 Russia 10c; 7 Siam 15c; 10 Straits 7c; 30 Sweden 11c; 100 U.S. 20c; 10 Uruguay 8c; 50 French Col's 34c; 50 Portuguese Col's 35c. Following wonderful collections guaranteed to satisfy or your money back: 1000 varieties \$2.90; 1500 varieties \$5.45; 2000 varieties \$8.90. Postage extra. Remit in stamps or money order. We buy stamps. **MARRS STAMP CO., Dep't N, TORONTO, CANADA.**

## 75

**STAMPS.** Each from a different country — only 50c — send for packet No. 248, 100, all different, from Africa — only \$1.00, packet No. 223. Send for free price list — thousands of stamp bargains.

### SCOTT STAMP AND COIN CO.

33 West 44th Street New York City



**65c for 8c.** Abyssinian stamp, Guatemala Parrot stamp, Packet 30 varieties British Colonies, cat. 65c. Packet Hinges. Large mm. scale, perf. gauge and wmk. detector. Price list and finest 50% approvals all for 8c. **WE BUY STAMPS.**

**ALLEN SEARS, Inc.**

Dept. S, Suite 508 Kemper Bldg., Kansas City, Missouri.



### 158 Genuine Foreign Stamps

Mexico War issues, Venezuela, Salvador and India Service, Guatemala, China, etc. Only **10c** Finest Approval Sheets 50 to 60%. Agents Wanted. Big 72-page Lists Free. We buy Stamps. Estab. 29 yrs. **Hussman Stamp Co., Dept. 52, St. Louis, Mo.**

### QUICK SERVICE!

When you want stamps you want 'em quick. And I have just the kind you want; clean, well arranged, up to date approval selections at 50% disc. with extra discounts for prompt returns. The general collector will be delighted. Try them and you will say "How does he do it?"

D. M. WARD, 608 Buchanan St., Gary, Ind.

P. S. 3 Aguinaldo Philippine Stamps free to approval applicants.

65 Different Foreign Stamps from } including Africa, Asia, Aus-  
65 Different Foreign Countries } tralia, Europe, West Indies  
and our pamphlet, which tells you "How to make your collection of stamps properly." For only 16 Cents—A BIG BARGAIN.

**Queen City Stamp & Coin Company,**  
Room 32 604 Race St., Cincinnati, O.

Stamps 50 all diff., Africa, Brazil, Peru, Cuba, Mexico, Ceylon, Java, etc., and Album, 10c. 1000 Finely Mixed, 40c. 50 diff. U. S., 25c. 1000 hinges, 10c. Agts. wtd., 50%. List Free. I buy stamps.  
C. Stegman, 5940 Cote Brillante Ave., St. Louis, Mo.



(Continued on next page)



**STAMPS**—(Continued from preceding page)

**STAMPS—20 VARIETIES, UNUSED, FREE** to all sending for our approval sheets at 50% discount. Postage 2 cents. Mention St. Nicholas. **QUAKER STAMP CO., TOLEDO, OHIO.**

**FREE** 2 GERMAN AEROPLANE STAMPS to approval applicants. Reference required. J. R. NICHOLS, 2322 Loring Pl., New York City.

**DANDY PACKET STAMPS** free for name, address 3 collectors, 2c postage, with 50% apprs. 125 dif. U. S. inc, high values, 50c. U. T. K. STAMP CO., UTICA, N. Y.

**Stamps Free** Fine set War Stamps, Surcharged, Unused, Pictorials, British, French Col's with Big Price List, 2c postage. **MIDLAND STAMP CO., Toronto, Canada.**

**FREE** Packet of fine stamps for names and addresses 2 live collectors, and 2 cents postage. **HIAWATHA STAMP SHOP, Syracuse, N.Y.**

**STAMPS** 105 China, etc., stamp dictionary, list 3000 bargains, 2c. Album (500 pictures), 3c. **BULLARD & Co., Sta. A, BOSTON.**

**FREE** List of sets and approvals. **HUB POSTAGE STAMP Co., Inc., 345 Washington Street, Boston, Mass.**

**FREE** 7 beautiful French Colonials, to approval applicants. **FRANK HADLEY, Box 73, Plainfield, N. J.**

**200** diff. Stamps 18c; 100, 9c. 20 Persia 20c, Hinges 1000, 12c. Lists Free. **MICHAELS, 5602 Prairie, Chicago.**

**10 STAMPS FREE WITH TRIAL APPROVALS** (Cat. 20c) **F. E. THORP, Norwich, N. Y.**

**FREE** pictorial set (ten stamps) to new applicants of approval sheets. References please. **H. R. STEVENS, 334 Madison Street, BROOKLYN, N. Y.**

**20** different BRITISH COLONIAL stamps, **R. H. A. GREEN, 821 Main St., Evanston, Ill. 10c**

**DOMINICA** WARS.  $\frac{1}{2}$ d.  $1\frac{1}{2}$ d. Cat. 25c. Net 8c. **A. C. DOUGLAS, A.S.D.A., Lucan, Ont.**

**FOREIGN STAMPS FREE**—Big Variety Packet Foreign Stamps from all over the World. 2c postage. **GRAY STAMP Co., Station E., Toronto, Canada.**

**25** Gold Coast, Newfoundland, India, etc. **FREE** with trial approval sheets. 500 different stamps 90c; 1000 all different \$2.25. Hinges 10c per M. **F. J. STANTON, Norwich, N. Y.**

**FRENCH COLONIES FREE**—Set Used and Unused Pictures, Wild Animals, Native Chiefs, Scenery and big bargain List. 2c postage. **EMPIRE STAMP Co., Toronto, Canada.**

**1500** different stamps \$5; 1000, \$2.50; 550, \$1; 300, \$45; 200, \$20; 100, \$10. **F. L. ONKEN, 630 79th St., Brooklyn, N. Y.**

**BARGAINS**—Roumania No. 923-4, rare 75c. Approvals 60% disc. **LISTS FREE. B'WAY STAMP Co., 115 Nassau St., N. Y.**

**ST. NICHOLAS STAMP PAGE**

(Concluded from second preceding page)

for the transportation of mail through the air. It would hardly seem that this airplane service of delivering mail had reached sufficient proportions to entitle it to having a paper dedicated to its especial line of stamps. But such seems to be the case. From reading the paper, we gather that those who specialize in this line of stamp-collecting are eager to get all advance knowledge of the installation of new service routes. They desire particularly to obtain entire covers where the cancelation shows that the letter went on the "first trip" of the new route. We learn from this new publication many interesting little facts about this new branch of our chosen pursuit. Already there are in existence albums especially prepared for the holding of airplane stamps. There are priced catalogues of these issues, and histories of them. In fact, there has already accumulated quite a little bibliography concerning them. This paper, No. 1, Vol. I of "Air Mail" has a very interesting account of the French Balloon Mail, which was originated in 1870 by the French, who were then besieged in Paris by the Germans. The paper publishes a list of the dates of each ascension and the place of its landing. Since then, there have been many trips of airplanes of various kinds on which mail has been carried, and where the envelopes so carried were postmarked by specially designed cancelations. But to Italy belongs the honor of issuing the first stamps specifically for air-mail use. This was in May, 1917, for use between Rome and Turin. Austria followed suit in March, 1918, and the United States was third, giving us in May, 1918, the famous twenty-four-cent rose, which has in the center the large blue airplane. And now these airplane routes are being established all over the world. This new outlet for philatelic energy is growing apace.

**RARE POSTMASTER PROVISIONALS**

It doubtless will interest our readers to know some other prices at the Ferrari sale described last month. Most of them know that in the catalogue there are listed at the very beginning of United States a group of stamps called "Provisional Issues by Postmasters." These were actual stamps used for postage, but they were not a governmental issue. They appeared before the first regular issue in 1847. Yet while they were not really full-fledged postage-stamps, with the backing of a national issue, they are very interesting, especially to collectors here in our own country. Let us look again at the catalogue for No. 11A. This we find was a Provisional issued by the postmaster at Boscawen, New Hampshire. Again, the catalogue informs us that of this stamp only one copy is known. This Provisional stamp comes home to America, and the price paid for it was somewhat in excess of eleven thousand dollars. We might say also that the first stamp in the catalogue, "Scott's No. 1," the five-cent Alexandria on buff paper, another Postmaster Provisional, also was bought by an American, a dealer, for about six thousand dollars. We might go on with quite a long list of other stamps which sold for prices well into the thousands. But we have told enough to establish what is the most valuable stamp in the world.

# An "Eagle" Offer

HERE'S what Frank Craven, author and star in "The First Year," one of New York's greatest stage successes, and golf enthusiast, thinks of our combination offer of a year's subscription to THE AMERICAN GOLFER, THE SPORT PICTORIAL, and the Five-Volume Memorial Edition of sport stories by the late Charles E. Van Loan.

*Dear Grantland:*

*I want to tell you what a smart fellow I think I am in taking a year's subscription to The American Golfer, along with the Van Loan stories. I had read a number of them. Now I have finished them all, and to me they are like playing a golf course—better for doing a second time.*

*I have no hesitation in saying it is an "eagle" offer.*

*Sincerely yours,*

*(Signed) Frank Craven.*

The five volumes of sport fiction, forty-nine stories in all, are the following:

**FORE!**—Stories of the links.

**OLD MAN CURRY**—Racing stories.

**TAKING THE COUNT**—Stories of boxing.

**SCORE BY INNINGS**—Baseball stories.

**BUCK PARVIN AND THE MOVIES**—Moving picture stories.

THE AMERICAN GOLFER, THE SPORT PICTORIAL, is edited by Grantland Rice, the most widely read writer on sport subjects in the country. It appears every other Saturday—twenty-six issues a year—and alone sells for five dollars a year.

Fill in the coupon below and send in your order today.

CENTURION PUBLISHERS, INC.  
353 Fourth Avenue, New York City

S.N. 8-22

Enclosed find \$10.00, for which send me THE AMERICAN GOLFER, THE SPORT PICTORIAL, for one year (26 issues); and the 5-volume Memorial Edition, boxed and express paid.

*Magazine and Books may, if  
desired, be sent to separate  
addresses.*

Name.....

Address.....

Postage in Canada, 50 cents; foreign countries, \$1.00.





“AD”  
VENTURES of the

# IVORY HEROES

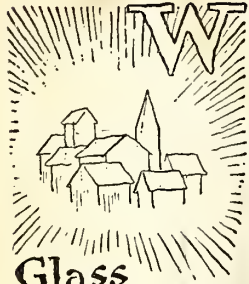
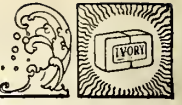

## Glass Houses. Chapter VIII.

THE houses all were made of glass; also the streets and floors! so, too, were roofs and furniture, the windows and the doors. But smoke and dust had come in clouds; the rain in floods had run, until the mud upon the roofs had quite obscured the sun. The folk had almost lost their sight from lack of light to use it, for if you do neglect a sense, you're very apt to lose it. Experience had taught our Gnif, and Bob and Betty, too, that here they'd found the very task for IVORY SOAP to do. In Betty's suitcase she had put some kerosene and bluing—

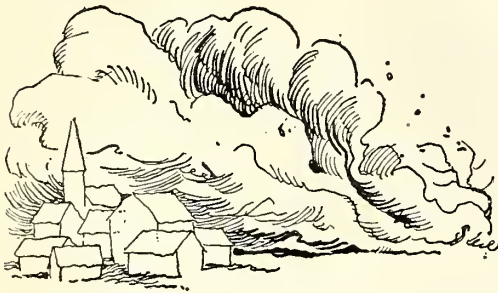

“In cleaning glass,” she had remarked, “there might be something doing.” They melted lots of IVORY SOAP, and added oil and blue, and then applied it to a roof to see what it would do. Ere long they heard some shouts within; a man came running out. The sun had pierced his gloominess and put the dark to rout. He called his neighbors all to help, and under Gnif's direction, they scrubbed that town both up and down, till it approached perfection.

The houses sparkled in the sun, reflected, scintillated. It was the fine achievement which that town had long awaited. They celebrated for a week with pageants, fires, and boats. They had some fine processions with a lot of IVORY floats. And when they pressed him for a speech, Gnif bade them all adieu, and said,

“It merely goes to show what IVORY SOAP can do.”

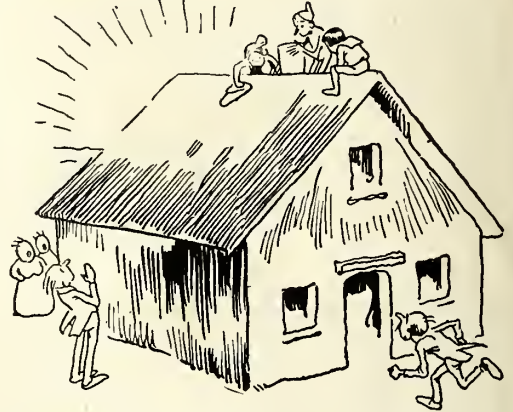

“And furthermore,” said little Gnif,  
“No one can ever hope  
To live in peace or purity,  
Without our IVORY SOAP.”

Don't you want to see how and when these marvelous adventures began? Then write to your friends, The Procter & Gamble Co., Cincinnati, Ohio, asking for a little book called “THE CRUISE OF THE IVORY SHIP,” by John Martin. It is a wonderful little bedtime book, given FREE to you.



**IVORY**  
IT FLOATS  **SOAP**  
99 <sup>44</sup>/<sub>100</sub> % PURE



# ST. NICHOLAS



THE CENTURY CO

353 FOURTH AVENUE, NEW YORK

THE CENTURY

AND ST. NICHOLAS



*Reynolds*





## *Two Good Bites* Which will he attend to first?



A cake of Baker's Sweet Chocolate for lunch and when he gets home a cup of delicious, wholesome Baker's Cocoa with his supper.

*Sweetmeat, food and stimulant in one.*

*"Practical experience long ago decided that chocolate is a good sustaining food."* — The Lancet, London, Eng.

**WALTER BAKER & CO. LTD.**

REG. U.S. PAT. OFF.

Established 1780

DORCHESTER, MASSACHUSETTS

*Booklet of Choice Recipes sent free.*

# WRIGLEY'S

## for Better Digestion



When you've eaten fully and have a stuffy feeling—or when your stomach is unruly and feels upset—**WRIGLEY'S** will bring relief and make you feel fit again.

It calms and soothes the stomach and nerves, aids appetite and digestion, keeps the mouth sweet and teeth clean.

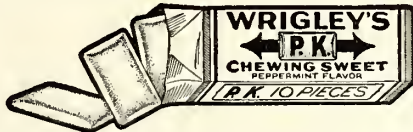

Wrigley's P. K. is the new double treat—peppermint sugar jacket over peppermint chewing gum.

Sugar jacket just "melts in your mouth," then you get the delectable chewing center with all the usual Wrigley benefits.



Save the Wrappers They are



Good for Valuable Premiums

C90



(The entire contents of this Magazine are covered by the general copyright, and articles must not be reprinted without special permission.)

## CONTENTS OF ST. NICHOLAS FOR SEPTEMBER, 1922

<b>Frontispiece: " Her face fairly beamed as Doug introduced his friends."</b>		
<small>Drawn by Edward C. Caswell</small>		
<b>Remarkable Sue.</b> Story .....	Ruth Kathryn Gaylord . . .	1123
<small>Illustrated by Donald Teague</small>		
<b>The Radio Message.</b> Story .....	George Ethelbert Walsh . . .	1128
<small>Illustrated by W. P. Couse</small>		
<b>Will He Dare?</b> Picture. Painted by M. S. Johnson .....		1133
<b>The Weaver of Dreams.</b> Verse .....	Henry C. Pitz .....	1134
<small>Illustrated by the author</small>		
<b>The Workshop of the Mind. VI.</b> .....	Hallam Hawksworth .....	1135
<small>Illustrations by Albert E. Sterner and Fromentin</small>		
<b>Taking a Hint from Hannibal.</b> Story .....	Merritt P. Allen .....	1141
<small>Illustrated by C. M. Relyea</small>		
<b>The Story of the Trolley.</b> Sketch .....	T. Commerford Martin . . .	1147
<small>Illustrated by H. W. Colby, Jay Hambidge, and from photographs</small>		
<b>The Thoroughbred.</b> Story .....	A. May Holaday .....	1155
<small>Illustrated by Edward C. Caswell</small>		
<b>The Biggest Top in the World.</b> Sketch .....	Harvey W. Root .....	1163
<small>Illustrations from photographs</small>		
<b>The Mystery at Number Six.</b> Serial Story .....	Augusta Huiell Seaman . . .	1165
<small>Illustrated by W. P. Couse</small>		
<b>Farmer Rabbit and Doctor Tortoise.</b> Picture. Drawn by Clifton Meek .....		1172
<b>Giving a "Show."</b> Sketch .....	Charles K. Taylor .....	1173
<small>Illustrations from photographs</small>		
<b>The Turner Twins.</b> Serial Story .....	Ralph Henry Barbour . . .	1175
<small>Illustrated by C. M. Relyea</small>		
<b>The Oddsocks.</b> Story .....	Morton Gibbons-Neff . . .	1183
<small>Illustrated by George Varian</small>		
<b>The Inca Emerald.</b> Serial Story .....	Samuel Scoville, Jr. . . . .	1189
<small>Illustrated by Charles Livingston Bull</small>		
<b>The Handicap.</b> Story .....	Brewer Corcoran .....	1196
<small>Illustrated by C. M. Relyea</small>		
<b>The Young Cowboy.</b> Picture. Drawn by Charles F. Lester .....		1203
<b>In the Blood.</b> Story. (Conclusion) .....	Kenneth Payson Kempton . . .	1204
<small>Illustrated by I. W. Taber</small>		
<b>Up by Stony Lonesome.</b> Verse .....	Eleanore Myers Jewett . . .	1210
<b>The Watch Tower.</b> A Review of Current Events. Illustrated .....	Edward N. Teall .....	1211
<b>Nature and Science for Young Folk.</b> Illustrated .....		1216
<small>The California Road-Runner (Edmund C. Jaeger) — A Wind-Tunnel for Testing Tiny Planes (George F. Paul)</small>		
<b>For Very Little Folk:</b>		
<b>Tom-Tot and the Dwarf.</b> Story. Illustrated by Harold Sichel .....	Edna Groff Deihl .....	1220
<b>The St. Nicholas League.</b> With Awards of Prizes for Stories, Poems, Drawings, Photographs, and Puzzles. Illustrated .....		1222
<b>The Letter-Box</b> .....		1230
<b>The Riddle-Box</b> .....		1231
<b>St. Nicholas Stamp Page.</b> Conducted by Samuel R. Simmons .....	Advertising Pages	



*The Century Co. and its editors receive manuscripts and art material, submitted for publication, only on the understanding that they shall not be responsible for loss or injury thereto while in their possession or in transit. Copies of manuscripts should be retained by the authors.*

In the United States, the price of ST. NICHOLAS MAGAZINE is \$4.00 a year in advance, or 35 cents a single copy; the price of a yearly subscription to a Canadian address is \$4.35. The price of a yearly subscription to a foreign address is \$4.60. We request that remittances be by money-order, bank check, draft, or registered letter. The Century Co. reserves the right to suspend any subscription taken contrary to its selling terms, and to refund the unexpired credit. PUBLISHED MONTHLY.

The half-yearly parts of ST. NICHOLAS end with the October and April numbers respectively, and the red cloth covers are ready with the issue of these numbers; price \$1.00 by mail, postpaid; the two covers for the complete volume, \$2.00. We bind and furnish covers for \$2.00 per part, or \$4.00 for the complete volume. (Carriage extra.) All copies of this magazine which are to be bound must be sent to our New York office. In sending the numbers to us, they should be *distinctly* marked with owner's name. Bound volumes are not exchanged for numbers.

All subscriptions for, and all business matters in connection with, ST. NICHOLAS MAGAZINE should be addressed to

### THE CENTURY CO.

Publication and Circulation Office, Concord, N. H.

Editorial and Advertising Offices, 353 Fourth Ave., New York, N. Y.

W. MORGAN SHUSTER, *President*  
DON M. PARKER, *Secretary*

GEORGE L. WHEELLOCK, *Treasurer*  
JAMES ABBOTT, *Ass't Treasurer*

#### BOARD OF TRUSTEES

GEORGE H. HAZEN, *Chairman*

W. MORGAN SHUSTER

GEORGE INNESS, JR.

(Title Registered U. S. Pat. Off.)

(Copyright, 1922, by The Century Co.)  
(Printed in U. S. A., and Entered as Second Class Matter, September 4, 1920, at the United States Post Office, Concord, N. H., under the Act of March 3, 1879. Entered at the Post Office Department Ottawa, Canada.)

Marietta Cox, Greencastle, Ind.



"We are advertised by our loving friends"

# Mellin's Food Babies

Thousands of mothers can testify that the Mellin's Food Method of Milk Modification satisfactorily solved their infant feeding problems. Do not deprive your baby of the good health to be obtained from the proper use of Mellin's Food and fresh cow's milk.

*Write today and ask us to send you a Free Trial Bottle of Mellin's Food and a copy of our book, "The Care and Feeding of Infants."*

Mellin's Food Co., Boston, Mass.



Robert E. Wright, Wooster, Ohio



Frances E. Cruikshank, Bristol, Tenn.



# ST. NICHOLAS

---

## NEXT MONTH AND TO COME

---

### Marooned in Crater Lake      ALFRED POWERS

Nineteen one-cent stamps offer the suggestion of a method of escape from a narrow ledge in Crater Lake, when *Jim Turner* finds himself alone and forgotten on the last day of the tourist season, and they also furnish the chief means.

### The Oldest Printing Establishment HENRY TUCK SHERMAN

A personally conducted "tour" of the famous Plantin printing-house in Antwerp, home of Europe's foremost publisher for three hundred years. Illustrated by Joseph Pennell.

### Felicia Explains — Finally MARGARET MACDONALD

To explain this story to you in advance would make *Felicia's* explanations unnecessary. All we shall say is that it is a clever story and well worth anticipating.

### Trapped by the Red Terror WALLACE HUTCHINSON

Another *Ranger Bill* story — how the famous forest ranger found that dumb animals had better judgment than he.

### The Lightning-Stone      ERIC P. KELLY

A good-luck piece seems to bring misfortune to this Polish boy for the moment, but in the end fortune smiles on him.

### Blazes, Bruce, and Bed-Springs      EDWARD MOORE

This boy's wit, combined with his knowledge of wireless, saves a town from destruction by fire.

# Back to Books

IT'S a bit difficult at the start, isn't it, to get into the swing of classes again? The out-of-doors is still too pleasant to leave, and it is hard to keep thoughts of camp and the fun enjoyed there from dividing one's attention.

ST. NICHOLAS understands this very well, for he is young himself. He is getting into his fiftieth year, to be sure, but he is still the chum of boys and girls and as spry as ever.

It is this keen understanding of the problems which face boys and girls that endears ST. NICHOLAS to them. His cheerful counsel is worth a dozen admonitions.

And so it is with school and his help with the every-day lessons. There's so much about ST. NICHOLAS that is informing that it fits right into the scheme of study. Many readers say that teachers ask them to bring their copies of ST. NICHOLAS to school, whereas other books and magazines — outside the prescribed text-book list — are often frowned upon. One North Carolina high-school girl writes: "When I took the April

number to school, Miss Taber, the Latin teacher, borrowed it to read 'A Live Latin Club,' and she said she was going to try the plan mentioned in it." A thirteen-year-old Idaho high-school pupil says: "You can't imagine what a help you are. In civics class we use you a lot, for your 'Watch Tower' is very interesting. Then, just a little while ago, our grammar teacher liked the English play, 'I'll Try,' which was published in the January, 1921, ST. NICHOLAS, so well that she let us give it for a public benefit."

And these are but two letters, picked at random from the budget of enthusiastic letters we receive every day.

You are a reader of ST. NICHOLAS, doubtless, but are you a member of that large and ever-growing family of regular subscribers? If not, you ought to be, for the *occasional* reader misses a great deal — the serials, especially. And in November we shall begin some new "to-be-continued" stories. Get your order in now, so that you will begin with the new volume and ST. NICHOLAS's new year.

THE CENTURY CO. { Concord, N. H., or  
353 Fourth Avenue, New York City:

S.N. 9-22

Gentlemen: Please find enclosed \$4, for which send ST. NICHOLAS for one year, beginning with the October number, to

Name..... Street .....

City..... State .....



# School Clothes for the Boy



**M**OTHERS of well dressed boys will look with favor upon these suits and coats. They have that careful tailoring that is usually found only in the clothes of fastidious grown-ups.

A—A distinctive suit because of the sturdy, bright, fine quality tweed of which it is made—and because of the little vest. Sizes 3 to 10. \$7.44, \$10.74, \$14.74

B—A fine looking Norfolk suit with two pairs of knickers. In either tweed or cassimer, the price range according to the quality of the material. Sizes 8 to 17. \$19.74, \$24.74, \$27.75



C—A big, warm, fine looking overcoat. Of all-wool overcoating lined with plaid. Priced according to the quality of the fabric. Sizes 16 to 18 years. \$24.74, \$29.75

D—Sport or school suit with inverted "golf pleat" back, two pairs of knickers, one with wide knee cuffs. Fine tweed or cassimers. Sizes 9 to 18. \$22.74, \$24.74, \$27.75

E—Small boy's overcoat with raglan sleeves. Made of soft, warm overcoating and lined with all-wool plaid. Tan, gray and brown mixtures. Sizes 4 to 10. \$17.74

F—This gray, tan or brown tweed midy suit, with two pairs of little straight trousers, is trimmed with white or black braid and has an extra white pique collar. Sizes 4 to 10. \$7.44

**R. H. Macy & Co.**  
HERALD SQUARE Inc. NEW YORK

# and for the Junior Girl



THESE little frocks and wraps have the charm of dignity in spite of their youthfulness. They will satisfy a young girl's fancy and a mother's discretion. Fabrics and tailoring of exceptionally fine quality make them excellent values at these very moderate prices. And serviceable garments they are, indeed, for the junior school girl.

1—The darker portion of this dress is of woolen crepe, the lighter of jersey. In the following color combinations—navy crepe and jade jersey, navy crepe and henna jersey, brown crepe and tan jersey. Sizes 12 to 16. \$9.74

2—Woolen crepe needs only silk braid to set off its charming texture. Tiny tailored pockets top the rows of braid. This little frock comes in navy, red, light brown and Copenhagen. For girls between 6 and 14 years of age. \$13.74

3—The contrast of velvet and crepe de chine is softened here by silken braid of clear, bright colors. Black with gray, brown with tan, navy with Copenhagen sleeves. 12 to 16. \$17.74

4—This frock of navy blue poiret towll has straight and slender lines and a gallant touch of woven silk braid, red, green and a thread of gold. Sizes 12 to 16. \$15.74

5—All wool Chinchilla lined with flannel makes a practical coat for the school girl between 6 and 16 years. Navy blue lined with bright red; deer, henna, brown lined with self color. \$15.74

6—A luxurious collar of natural racoon is the rich, warm feature of this well-tailored Polo coat. It comes in Copenhagen blue, brown and deer color. Sizes 8 to 16. \$23.74



R. H. Macy & Co.  
HERALD SQUARE Inc. NEW YORK



# To All Parents!

THE influence of the school is one of the vital factors in the forming of the character of every boy and girl. How important is it, then, that the right school is chosen at an early stage of the child's educational development.

☞ The children themselves should be first considered in the selection of their school. This seems like a perfectly obvious statement, but how many overlook it. Children do not like to be forced to attend a school in the selection of which they had no choice, any more than they like to wear clothes which are not their own. The boy or girl is the one primarily concerned, and their wishes should be first consulted, always supplemented, of course, by the parents' advice and counsel.

☞ But how, you say, can the children be made interested in the selection of their school? By starting them thinking about it. Let them read the advertisements, write for the catalogue and other information, compare the various schools with each other, etc., etc. By this means their interest and enthusiasm are aroused, and you can depend upon it that their final choice will be a wise one.

☞ The School Advertising Section of St. NICHOLAS magazine contains many excellent schools, located in many parts of the country, and varying in facilities, curricula, and opportunities for physical development. Let your children look over this section, and then, if they do not find the type of school they want, advise them to write to us and we shall be glad to help them in every way possible.

## The School Service Bureau, St. Nicholas Magazine

353 Fourth Avenue, New York City

ST. NICHOLAS SCHOOL SERVICE DEPARTMENT  
353 FOURTH AVENUE, NEW YORK CITY

S.N. 9-22

*Please have information about schools sent to me:*

My age is .....

Name of school I have attended .....

Name .....

Address .....

Location desired .....

Large or small school .....

Type (i. e. Boarding, Military, etc.) .....

Parent's .....

Signature .....

# GOOD SCHOOLS

FOR  
BOYS and GIRLS

## COLUMBIA PREPARATORY



### SCHOOL BOYS GIRLS



Preparation for all Colleges and Universities. Sponsored by University Presidents. Patronized by University faculties. Member University of State of New York.

Day and Resident—Primary to College

*Combining the most progressive methods of education with the cultural advantages of New York*

Ideal home life for refined, cultured girls and boys of all ages, under an experienced faculty composed of Europe's and America's most eminent teachers, who are masters in social and academic training. Separate departments for Art, Music, Dramatic Art and Junior Divisions.

DR. S. N. CLAWSON, *Principal*

301 W. 88th Street, Cor. West End Avenue  
New York



## Southfield Point Hall

A School for Girls. Beautifully situated on Long Island Sound at Southfield Point. Intermediate, general, and college preparatory courses. Music, gymnastics, athletics, and sports. Horseback riding, skating, skiing. 52 Minutes from Grand Central Station, New York. Limited enrollment.

JESSIE CALLAM GRAY, B.A., *Principal*

BERNICE TOWNSEND PORTER, *Assistant Principal*

10 Davenport Drive, Stamford, Conn.



250 Boys 22 Men

\$800,000 Equipment

89th year opens September 19th

## WORCESTER ACADEMY

WORCESTER MASSACHUSETTS

Rates: \$1000 single  
\$850 double

Junior School for young boys

For catalog address the  
Registrar, G. D. Church, M.A.

SAMUEL F. HOLMES, M.A., *Principal*

## Whiting Hall

### A Country Home School for Girls

from eight to sixteen, affiliated with the best preparatory schools. Twenty-six acres, modern buildings, new gymnasium, ideal location, high elevation — halfway between Boston and Worcester, near Longfellow's Wayside Inn. Outdoor sleeping and class rooms, if desired. Individual care. Teachers for all branches. Mistress of field games. House mother. Family life emphasized. Tenth year.

MR. ELBRIDGE C. WHITING, Amherst, Yale, MRS. WHITING, Wellesley, Prins.  
CONCORD ROAD, SOUTH SUDBURY, MASS.





## Miss Hall's

SCHOOL FOR GIRLS

In the Berkshire Hills, on the Holmes Road to Lenox. Forty-five acres. One thousand feet above the sea level.

Miss MIRA H. HALL, Principal  
Pittsfield, Massachusetts



## The Castle

Junior Department of Miss Mason's School  
For the little girl who wants a school like older sisters. Work and play directed for the steady development of the child from 6 - 12 years of age. Unsurpassed advantages. Near New York City. Rate \$1000. Catalog.

Miss C. E. MASON, Principal  
Box 725, Tarrytown-on-Hudson, N. Y.



## Lincoln School

A school for girls, offering country life with the advantages of the city. Preparation for college examinations, and general courses. Exceptional opportunity for outdoor sports. Horseback riding.

Miss Miriam Sewall Converse, Principal  
Providence, Rhode Island



## PAGE MILITARY ACADEMY

A Big School for Little Boys

A school whose military system is modified to meet the needs of growing boys. Thoroughness in primary and grammar grade work goes hand in hand with military training to inculcate orderliness, promptitude and obedience. Page will give your boy the right start toward earnest, successful manhood. The high, healthful location between city and ocean affords a beautiful home in a matchless climate.

You should have the latest Page catalog.

Address  
ROBERT A. GIBBS, Headmaster  
Route 7, Box 947  
LOS ANGELES CALIFORNIA

## Starrett School for Girls

Thirty-seventh year. Academic, college preparatory and special courses; also seventh and eighth grammar grades. Co-operative with the University of Chicago; prepares for Smith, Wellesley and Vassar Colleges. Member of the North Central Association. Full courses in all subjects offered by the best academic schools. European Trip — Summer 1923 — Credit given in History and Art. Exceptional advantages in Music and Art. A home school in elegant fire-proof building two blocks from Lake Front Park, Tennis Courts and Bathing Beach. Fall term begins Sept. 14.

Address Registrar, Box 28  
4932 Lake Park Ave., Chicago, Ill.



MASSACHUSETTS, Berkshire.

**CRESTALBAN** A school for little girls in the invigorating climate of the Berkshires. Thirty minutes from Pittsfield. 200 acres, 3 buildings. Number limited. Special care given to home training, character development, and health. Open-air classes. Outdoor sports.  
MISS MARGERY WHITING, Principal.

PENNSYLVANIA, Swarthmore.

**THE MARY LYON SCHOOL** A Country School in a College Town Preparatory for college. High scholastic standards. Music, Art, Languages, Home-making Sciences. Outdoor sports including canoeing. SEVEN GABLES — Junior School. WILDCLIFF — Graduate School. Write for catalogs.  
MR. and MRS. H. M. CRIST, Principals.  
Box 1542, Swarthmore, Pa.

MARYLAND, Catonsville.

## THE ROBERTS-BEACH SCHOOL

Limited number of girls, individual instruction. Strong college preparatory and general course. Outdoor life on ten-acre estate near Baltimore. Rooms with private bath. Box 900, Catonsville, Md.

NEW HAMPSHIRE, Concord.

## ST. MARY'S SCHOOL

A homelike school for girls. College preparatory and general courses.  
MISS M. E. LADD, B.L., Headmistress.

# BINGHAM SCHOOL, MEBANE, N. C.

ESTABLISHED 1793

AN IDEAL BOYS' SCHOOL IN PIEDMONT NORTH CAROLINA

Military organization, begun in 1861. High moral tone. Lovely lawns. Gymnasium. Athletic park. Bible and Physical culture emphasized. Honor System. Celebrated climate. Outdoor classes. Limited numbers. Sports in variety. 340 acres. Summer camp. A modern school with an ancient name, fame and history. Send for catalogue.

COL. PRESTON LEWIS GRAY, President, Box 8, Mebane, N. C.



# ABBOTT SCHOOL



☐ A boys' school in the beautiful, healthful hills of the Rangeley Region, 82 miles from Portland. Thorough preparation for college or business. High ideals of scholarship. Character and body building, maintaining the best traditions of New England Academies. Small classes insure close, personal touch of earnest masters.

☐ The physical development of boys is an important factor here. Exhilarating winter sports in the dry, invigorating air and an energetic outdoor life, together with gymnastic exercises and organized sports, combine to form sturdy bodies and happy minds. Gymnasium and fine athletic fields. Founded 1844. Upper and lower Schools.

Rate \$1200

Write for catalog

FARMINGTON, MAINE

## Woodland Park

Junior School for Lasell Seminary

Prepares for Lasell Seminary and other leading secondary schools. Careful direction under House Mother. Progressive methods of study and play. All the equipment of Lasell Seminary, with playgrounds, gymnasium and swimming pool. 15 Buildings. 30 Acres.

Camp Teconnet opens July 1.

Guy M. Winslow, Ph.D., Principal. Chas. F. Towne, A. M., Associate Principal. Woodland Road, Auburndale, Mass.



## The Hedges

NORTON, MASS.

The Junior School of **House in the Pines**. 30 Miles from Boston. For girls under fourteen. A large modern home. Sun parlors for class rooms. Play fields. Horseback riding. Swimming. A wholesome, simple life of study and play that makes the child quick to feel, eager to know, able to do.

MISS GERTRUDE E. CORNISH, *Principal*

# WILLISTON

JUNIOR SCHOOL

For Young Boys

Organized to develop the entire boy. Thorough work and graded athletics. Prepares for all leading preparatory schools. Home care, under House-mother, Head-master, and Special Faculty.

Rate \$700

Senior School prepares for college and scientific schools. A progressive school with 80 years of solid achievement behind it.

ARCHIBALD V. GALBRAITH, *Principal*  
Box N, Easthampton, Mass.

## SCHOOL INFORMATION

FREE catalogs and advice of experts on ALL Boys' or Girls' private schools (also camps) in U. S. Bureau maintained by the schools. No fees. Want for Girls or Boys? Call, phone or write

AMERICAN SCHOOLS ASSOCIATION

Times Bldg., Times Sq., N. Y.; also Masonic Temple Chicago



NEW JERSEY, Orange.

## MISS BEARD'S SCHOOL FOR GIRLS

A country school, 13 miles from New York. College preparatory, special courses. Music, Art, Domestic Science. Supervised physical work in gymnasium and field. Catalog on request.

LUCIE C. BEARD, *Headmistress*.

MASSACHUSETTS, Wellesley.

## TENACRE

A Country School for Girls 10 to 14. Preparatory to Dana Hall, 14 miles from Boston. All sports and athletics supervised and adapted to the age of the pupil. Finest instruction, care and influences. MISS HELEN TEMPLE COOKE, Dana Hall, Wellesley, Mass.

NEW YORK, Ossining-on-Hudson.

## OSSINING SCHOOL

For Girls. 54th Year. 30 Miles from New York. Academic and economic courses. Separate school for very young girls. For catalog, address CLARA C. FULLER, *Principal*. Box 9 N.



## Schools for Boys and Girls—Continued

CONNECTICUT, Cornwall.

### RUMSEY HALL

A School for Boys under 15. Yearly rate \$1300.  
L. R. SANFORD, *Principal*.  
L. OTIS H. SCHUTTE, M.A., *Headmaster*.

RHODE ISLAND, Providence.

### THE MARY C. WHEELER SCHOOL

*A Town and Country School for Girls*

College preparatory and General Course. Advanced Studio classes. Music. Secretarial Course. Farm Home for girls 10 to 14 years.

MASSACHUSETTS, South Byfield, Mass.

### DUMMER ACADEMY

A preparatory school for a limited number of selected boys. Ideal country location. Moderate fees. International reputation. 160th Year opens September 19.

PENNSYLVANIA, Rydal, Montgomery County.

**RYDAL** The Junior Department of the Ogontz School. A Home School for Girls 9 to 14. A teacher of strong personality, who has had unusual success in training little girls, is in charge. Enrollment is limited. Write for catalog.

MISS ABBY A. SUTHERLAND.

MASSACHUSETTS, Bradford.

### JUNIOR BRADFORD

A preparatory school for Bradford Academy. Directed study and play. Arts and crafts. All advantages of Bradford Academy equipment. For Booklets, address THE "PRINCIPAL," 139 Main Street, Bradford, Mass.

CONNECTICUT, New Canaan.

### STAMFORD MILITARY ACADEMY

Thorough scholastic and military training fostering the intellectual, physical and moral needs of developing boys. Personal instruction. Small classes. Manly sports encouraged. Extensive equipment. Ideally located in the Connecticut hills. Summer Camp.

WALTER D. GERKEN, A.M., *Principal*, New Canaan, Conn.

## Summer Camps

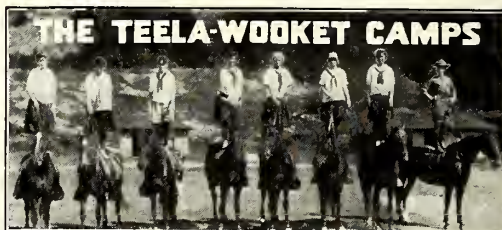

### THE TEELA-WOOKET CAMPS

**For Girls (under 20 years), Roxbury, Vermont**

A 300-acre wonderland in the heart of the Green Mountains. Athletic fields, private swimming pond, clay tennis courts, screened dining porch, sleeping bungalows, and a big assembly hall for plays, dances, music, and games around a big cheery fireplace. Famous for its fine saddle horses, free horseback riding, instruction, and wonderful camping trips. Separate camps for Juniors and Seniors. Enthusiastic counselors carefully chosen. Write now for illustrated booklet.

Mr. & Mrs. C. A. ROYS, 10 Bowdoin St., Cambridge, Mass.

## More New Books for Boys and Girls

### GOLF FACTS FOR YOUNG PEOPLE

By FRANCIS OUMET

THE "veteran" golfer, who has been amateur champion, victor in many hard-played matches, and is just as keen and expert a player as ever, gives to young people the advantage of his golf-wisdom, and the results of much observation, many friendships and wide contacts with the great game. He himself began golf young on an improvised course, and he understands the problems of youthful players: the pitfalls to be avoided, the difficulties under which they must sometimes develop their game.

*Illustrated. Price \$1.75*



### BROTHER ESKIMO

By ALAN SULLIVAN

A YOUNG Mowgli of the North," a professional reader called the hero of this book. He is carried away in his father's igloo on the ice-floe, far from any place he knows, with only his younger brother for companion. The strange life of the north, every condition of which is strange as dreamland to us, Mr. Sullivan knows well and describes accurately and fascinatingly. The two boys go through many adventures, in which wild animals play a large part, life itself depending upon their knowledge of the arctic creatures.

*Illustrated. Price \$1.75*

At All Bookstores  
Published by

**THE CENTURY CO.**

353 Fourth Avenue  
New York City

# The Book You've Been Wanting

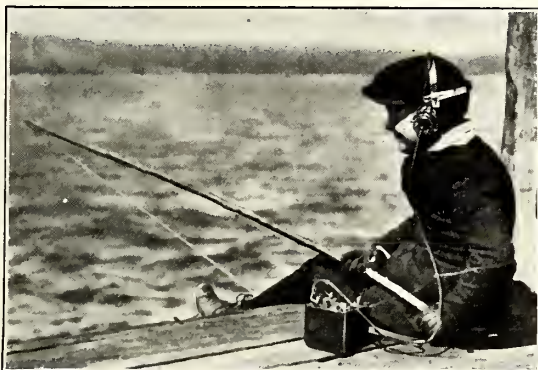

## THE COMPLETE RADIO BOOK

By Raymond Francis Yates and L. G. Pacent

**Q** DON'T YOU WANT to know radio better? — the thrilling story of its development from a ridiculed "crank" notion to the immensely popular and powerful thing it is today, when newspapers run columns and columns about it? Whatever other books you have about radio, if you are a real "bug" you want this one. It has chapters on the how and why of radio, with lots of diagrams, sketches and photographs; accounts of the latest wonderful things radio is doing all over the earth; a most fascinating history of the way radio was discovered and developed; and a Who's Who in radio of the greatest interest and value. No other radio book has so much of absorbing story-interest in addition to the scientific and practical part.

**Q** RAYMOND FRANCIS YATES is radio editor of "The New York Evening Mail."

LOUIS GERARD PACENT is one of the best-known radio engineers and inventors.

*The  
Century  
Co.*

353 Fourth Avenue  
NEW YORK CITY

I enclose \$..... for..... copies

THE COMPLETE RADIO BOOK

**\$2.00**

Send to.....

Address .....



# BY EDITH BALLINGER PRICE

**E**DITH BALLINGER PRICE was, not so many years ago, a young St. Nicholas League author. Her first published work appeared in that department when she was a young girl. It was very interesting work, and she had, besides, a double talent; for she is an artist, and illustrates the stories she writes. In but a few years she has come to be a very popular juvenile writer whose fifth book is just published — and it is, so far, her best.



## The Fortune of the Indies

A most exciting story of an old New England seaport town and of far-off China — a China of mystery and danger in which two boys have hair's breadth escapes. It is not merely a mystery story, however: it has the quality of charm that is native to the writer; it has the atmosphere of the old days of the clipper ships: it will appeal to plot-lovers and incipient style-lovers also.

*Illustrated by the author. \$1.75*

### BLUE MAGIC

A fascinating story of a crippled boy's adventures on the Nile and in Italy.

*Illustrated. \$1.75*

### THE HAPPY VENTURE

An especially charming story for young people of a plucky girl and boy and their little blind brother.

*Illustrated. \$1.75*

### SILVER SHOAL LIGHT

A story with plenty of thrill, of a summer's outing in a lighthouse on the New England coast.

*Illustrated. \$1.75*

### US AND THE BOTTLE MAN

A juvenile with a setting by the sea and a refreshingly original plot.

*Illustrated. \$1.75*

At All Bookstores  
Published by

**THE CENTURY CO.**

353 Fourth Avenue  
New York City

## *The Nature Books of Jean-Henri Fabre*

---

# A WONDER BOOK OF CHEMISTRY

This newly translated book by the great Frenchman will give any lively-minded, curious youngster a genuine insight into those mysteries of chemistry which, together with physics, form the foundation facts of our material world. Nothing is more marvelous than chemistry, and M. Fabre was a genius who felt and has conveyed the pure delight of its discovery, the intellectual joy there is in it. When chemistry can be made interesting to the point of being positively exciting — why should not eager young minds have wonder-tales that are true, and that are a true initiation into their world? This is a delightful, an excitingly interesting book. It is inevitably destined to prove a classic, and should be in the hands of every child.

*Illustrated, 8vo, 400 pages; price \$2.50*

### **OUR HUMBLE HELPERS— THE DOMESTIC ANIMALS.**

A particularly delightful book for children which will make every friendly animal more interesting and intimate.

*Illustrated, 8vo; \$2.50*

### **FIELD, FOREST AND FARM.**

Charming and useful lore of farming, gardening and fruit culture, set forth especially for young people.

*Illustrated, 8vo; \$2.50*

### **THE SECRET OF EVERY- DAY THINGS.**

Quaint and curious scientific information about the familiar objects of everyday life, charmingly presented.

*Illustrated, 8vo; \$2.50*

### **THE STORY-BOOK OF SCIENCE.**

A general account of the earth and its creatures which is as fascinating as it is accurate.

*Illustrated, 8vo; \$2.50*

## **ANIMAL LIFE IN FIELD AND GARDEN**

Stories of the more familiar wild life to be observed about country homes, treated from the standpoint of its relation to human life. Insect and mammal, bee and bat, make man's life easier or harder, his food scantier or more plentiful. "Uncle Paul" tells two little boys very surprising and entertaining stories of the creatures so important to man.

*Illustrated, 8vo; \$2.50*

---

At All Bookstores  
Published by

**THE CENTURY CO.**

353 Fourth Avenue  
New York City



## A Page of Barbour Books

# THE TURNER TWINS

By RALPH HENRY BARBOUR

**A** NEW STORY by Barbour is a great event to a large following of young people; and "The Turner Twins," his very latest, is in his jolliest manner, is chockful of fun, excitement and mystery, and makes the reader know as likable a group of characters as ever romped through a book.

The Twins were so much alike that no one could tell one from the other, and when having journeyed east from California they reached Hillman's School, they found the stage all set for their merry adventures. Hailed mistakenly as a football star, Ned philosophically accepted the situation, managed to conceal his colossal ignorance and won a place on the team. But it was his similarity to Laurie that saved him from disaster in the Big Game and only one other ever knew whether it was he or Laurie who kicked that winning goal and upheld the honor of the Turners!

That remarkable likeness helped again in the school entertainment and even Polly Deane, whose widowed mother kept the tuck shop, was startled. Polly was a great pal of the Twins, especially of Laurie, and it was Laurie who discovered the explanation of the mysterious sounds beneath the widow's cottage, solved the problem of what had become of old Coventry's money and so brought a happy Christmas to Polly and her mother.



*Illustrated. Price \$1.75*

### Other Books by Barbour

**Captain Chub.** Illustrations by Relyea. 12mo, 400 pages. \$1.75.

**The Crimson Sweater.** A capital story of athletics. Illustrated by Relyea. 12mo, 367 pages. \$1.75.

**Crofton Chums.** Illustrations by Relyea. 12mo, 338 pages. \$1.75.

**Harry's Island.** Pictures by Relyea. 12mo, 306 pages. \$1.75.

**Kingsford, Quarter.** Illustrated by Relyea. 12mo, 326 pages. \$1.75.

**Team-Mates.** Illustrations by Relyea. 12mo, 400 pages. \$1.75.

**Tom, Dick, and Harriet.** Illustrations by Relyea. 12mo, 384 pages. \$1.75.

### Books by Barbour and H. P. Holt

**The Mystery of the Sea Lark.** Illustrated. \$1.75.

**Fortunes of War.** Illustrated. \$1.75.

**Lost Island.** Illustrated. \$1.75.

At All Bookstores  
Published by

**THE CENTURY CO.**

353 Fourth Avenue  
New York City







"HER FACE FAIRLY BEAMED AS DOUG INTRODUCED HIS FRIENDS" (SEE PAGE 1160)

# ST. NICHOLAS

VOL. XLIX

SEPTEMBER, 1922

No. 11

Copyright, 1922, by THE CENTURY Co. All rights reserved.

## REMARKABLE SUE

By RUTH KATHRYN GAYLORD

WHEN Hilda Murray went back to college for her senior year, she carried with her a note from Aunt Louise: "Do find time to look up Sue Hubbard. She 's entering this year, and she 's really a remarkable girl. I want you to know her."

It was characteristic of Aunt Louise that she worded her sentence that way. After three years of college popularity, Hilda Murray was repeatedly begged to look up new girls; but the request was always couched the other way, and with the delicate emphasis of flattery: "I want her to know you."

The crowd of vivid girls who caught Hilda at the college gate and carried her off to register hung close about her room for weeks to follow. There are disadvantages in being "the most popular senior in college."

Hilda's room-mate voiced them: "Hil, you wretched thing, are you going to get off for Becca's tea to-night?"

"Tea—in Becca's room?" Hilda looked up from a clutter of note-books. "Oh, yes, I 'll try to get there. What 's up?"

"New girl. Becca's wild about her. Only wants your verdict to take her on."

Hilda was busy beyond all flattery. "I 'll get there if I can. If I don't show up before the end, tell her Physics Lab—or an Ec conference. It might be either."

Jo was in the very act of voicing Hilda's excuses when that lady dashed into Becca's room that afternoon. "Thanks, Jo; you were doing nobly, but I just did get here

after all! Tea, Becca? You know I love it. Oh, yes, and I do beg pardon, but— I 'm glad to know you. Suzanne Hubbard, did you say?" Munching a cookie, Hilda remembered suddenly. Sue Hubbard—the remarkable girl, of course!

"Entering senior," Becca murmured for her information.

Later, hurrying home across the campus, Jo reproached her. "You really went too far with her, Hil. She 's rather interesting, but you can't be sure just yet."

"I have reason to know that she 's rather —remarkable," Hilda shrugged. "Besides, I like the way she does her hair. It shows—well, temperament!"

Jo giggled despairingly.

Promptly Suzanne Hubbard was "taken on," and Hilda wrote home to her chum that she had found "a really remarkable girl, peppy and all that, you know." She had the grace to smile when she borrowed Aunt Louise's adjective.

"Bring her home some week-end," wrote Marj Frellick; "I 'll have a party and anything else you want."

Hilda's decisions were apt to be swift. Moreover, that coming week-end was miraculously free from quizzes. She penciled a hasty note, then scrawled a postal home and turned around—square into the arms of an adoring freshman.

Hilda saw a quick escape. "Oh, hello, Alice! Want to do something for me?"



Of course, Alice did—just ever so much. Hilda nodded gaily. "Take a note for me to Sue Hubbard. Know her?" Alice nodded wisely. "And hurry, won't you, Alice? It's important."

Alice hurried—so fast that Hilda remembered she had not inquired which dormitory. But there was always the college directory, and Alice was a faithful child. Moreover, Physics Lab was again calling.

Suzanne was rooming at the other end of the campus, and when Hilda found time to follow up the note with a more personal invitation, Suzanne's "single" stared an empty welcome. Hilda caught up the pad and pencil on the door and scrawled directions, "2:30 Sat. H. Murray."

On her way home, Hilda met another freshman. Freshmen were apt to lie in wait along her path. "Oh, Hilda, please! I want to thank you—"

Now Hilda hated thanks. "Don't say it," she urged, with a smile. The freshman was a pretty little thing, but evidently bashful. "How's the freshman world?"

"Oh, beautiful!" The freshman was eager. "But please, what train is it you're going on?"

From a chaos of physics computations and history reading, Hilda caught her straying thoughts. How did the child know she was going anywhere? The ways of freshmen were past finding out. "2:30," she nodded easily, and the freshman darted away.

Next morning there was a college note: "Thank you so much. I'll meet you at the gate. S. Hubbard."

Hilda frowned a bit over the writing. It certainly did not express Suzanne's temperament.

Then, through a whirl of lectures, meals, and packing, Hilda emerged in time for the train. Suzanne was not in sight. There was only a rather pretty girl who was coming toward her eagerly. "I'm here, you see!"

"Yes, I see." Hilda's smile was mechanical. "Seen Suzanne Hubbard round about?"

A dimple deepened in the girl's cheek, and Hilda remembered vaguely—this was the freshman who had thanked her for something or other. "I always call it Susan," she corrected, with a slight emphasis. "It's nice of you to ask me."

Ask her? Susan? Hilda sat down limply on her suitcase and stared at her. In that second she understood. There had been another Hubbard—Susan—in the freshman class. Suzanne had laughed about it, but

freshmen lived downtown, and Zanne had had no trouble over mail, she said. Alice had thought—

There was no time to figure out details. The train roared in. "Come," Hilda commanded. "Got your ticket?"

"I looked up where you lived in the directory," the girl explained.

With a start, Hilda came back to details. Deliberately, she smiled at Susan. "It's stupid of me, but I've been trying to remember where I met you—first, you know."

Susan reminded her. "I have n't seen you since, except in choir, of course. I was ever so much surprised when you asked me, but I love to come, and I suppose it's because your aunt knew my mother."

"Yes, yes." Hilda fumbled for her ticket. Then here was the remarkable Sue Hubbard bound for home with her! "I'm sure she does n't look remarkable," she thought. "I'll have to explain to Marj; she'll never get over it!"

Suddenly, Hilda's cheeks began to burn. A happy week-end it would be—explaining everywhere! And apologizing—Hilda caught herself. Why apologize? Susan Hubbard was pretty and she was the one Aunt Louise had meant all the time.

In her heart, Hilda was sternly just. It was downright mean to take the youngster home and pave the way with apologies. Marj and the rest would laugh and act queerly, and Susan might see and not understand. Well away from college, Hilda sat in the train and forgot that she was a popular senior. She was making up her mind to give Susan a happy week-end—the best to be had.

"I'll do it brown," she determined. Hilda Murray's "brown" promised everything.

But after all, Marj and her party were out of the question. Over the telephone, Marj plead in vain. "Hilda, honey, you're so horribly sudden about everything! I never dreamed you'd be home this week; and here I am up on the mountain. You'll just have to come up here and bring—"

Hilda cut her short. "Can't be done, Marj. I'll be home again before long. Besides, things changed the last minute, and I brought another girl instead."

She found Sue curled up in the window-seat. "Tell me, what would you rather do?"

"Just nothing," Sue answered comfortably, "or anything you like. I mean, I'll have a good time just being here with you."

"Let's go to the mountain to-morrow. There's a wonderful view of the valley."

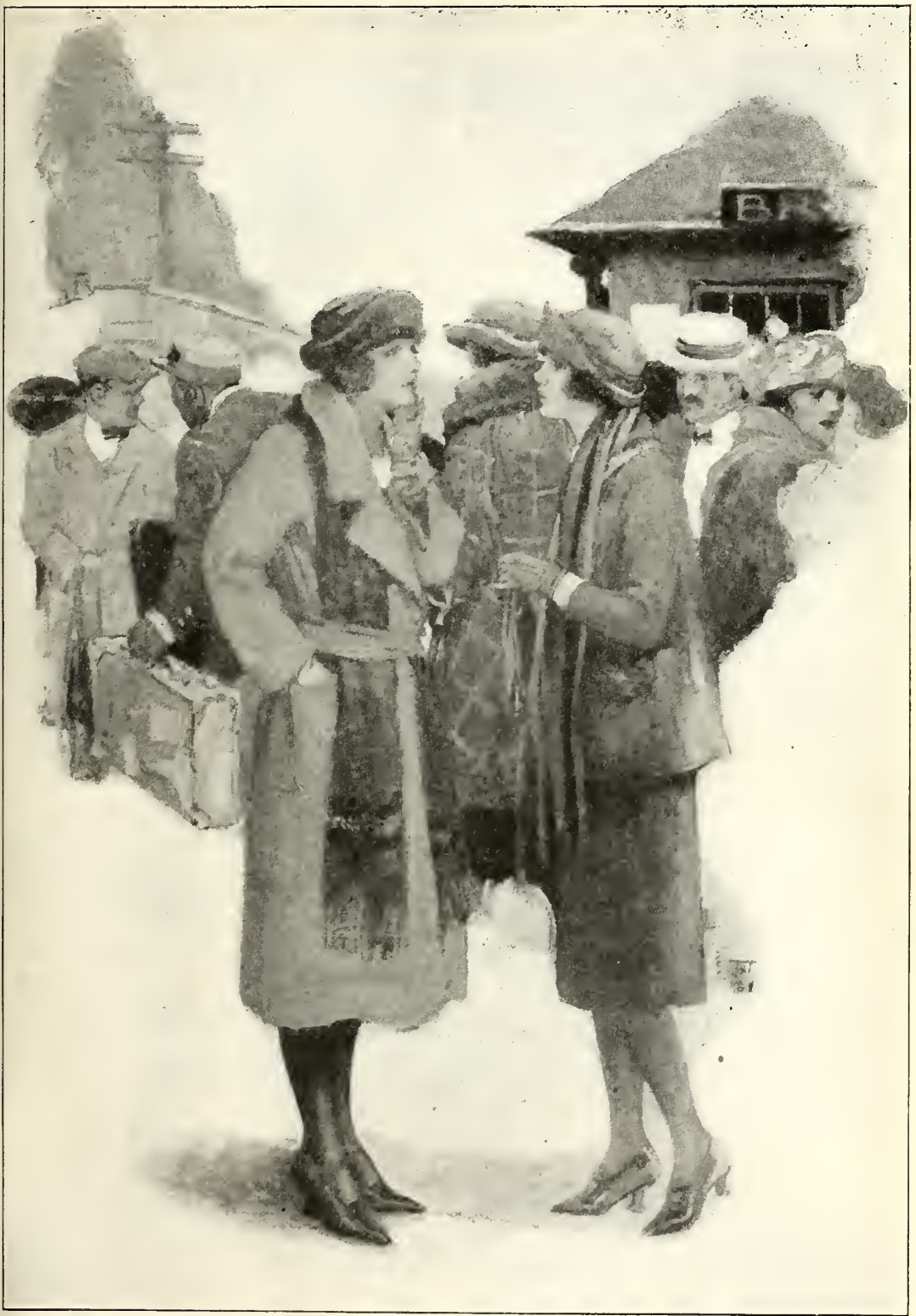

"THIS WAS THE FRESHMAN WHO HAD THANKED HER FOR SOMETHING OR OTHER"



Sue was used to tramping; Hilda knew that from the moment they swung off together. Moreover, Sue spoke but seldom, and Hilda liked to prowl along the trail with only the snapping of twigs for accompaniment.

At a crossing of paths, Hilda yielded to a sudden impulse. A moment later, they came in sight of a rambling mountain house where a crowd of young folks lolled about the veranda. The sound of singing and broken laughter drifted down, to the lilt of ukeleles. Hilda actually took a step toward the house. She wanted to join in the fun and be hugged and petted by Marj.

"Do you know those people?" Sue was asking.

Hilda turned swiftly. "Oh, yes, I know them. But I've changed my mind—we won't stop to-day." She put a hand on Susan's shoulder. "You would n't care about them, honey. Tell me, do you know any girls I do at college—except Alice?"

Sue lifted frank eyes. "I don't know Alice much of any, and nobody else at all. How do you do it?" The ukeleles throbbed in the distance as they started down the mountain. "Know so many people, I mean. They say you know more girls than any one else in college."

"Do they?" Hilda laughed. "There are times when I wish I did n't know so many."

"Oh, no!" There was horror in Sue's voice. "I'd give the world to know a lot of them. I think I could, too," she added simply, "if I could just get started. I don't know how to start."

Hilda reached for her hand. "Bless your heart, kiddie, I'll start you the minute we get back to college. It is easier when somebody helps a bit at first."

Hilda was vaguely conscious that she was laying out one more job than she had time for, but the delight in Susan's face led her on. "I'll be number one," she laughed, "and I'll guarantee that by the end of the year you'll know a hundred or two."

Sue gasped ecstatically. "A hundred—just *one* hundred—is a lot!"

Hilda thought swiftly of the hundreds she knew. She thought again of Suzanne and she puzzled a bit. Susan was a nice little thing, but certainly not remarkable. What in the world had Aunt Louise meant?

Mrs. Murray was watching from the piazza when they came in sight of home. "Oh, girls! could you get along somehow? Hilda, your father got a telegram—that business in New York, you know—"

"Of course; and you're going, too, for the ride." Hilda was firm. "No 'argifying,' Missis! Run along and pack your bag."

"It's so queer to leave you this way—"

"It'll be fun," Hilda assured her.

Next morning, over their breakfast, it was still fun. Susan, buttoned into a pink-checked apron, hovered about, making crispy toast, waiting on Hilda "hand and foot."

"You'd spoil me, if I was n't already," Hilda told her.

They slipped into church and found a pew near the door. "You'll like the soloist," Hilda whispered.

But she was not prepared for Sue's enthusiasm. At the first low note she sat erect, leaning a bit forward, almost breathlessly. The row of small children in front of them moved restlessly. Their mother motioned and threatened in vain. With a shiver, Hilda realized that the smallest girl had caught her breath to cry. It would ruin the music! The wail broke forth—paused.

With a sudden movement, Sue pushed past her, slipped into the seat beside the child, and bent her head to distract her attention. The sweet high voice sang on—without interruption.

"I hated to lose a word," Sue apologized, walking home again, "but the youngster would have spoiled it for everyone; and it was too beautiful to spoil."

With a touch of admiration, Hilda breathed, "It was dear of you to do it." It was all she could say. A queer little thought was tugging at her. Hilda Murray was realizing dimly that Sue had gone ahead of her, somehow. She smiled at her oddly now.

"My head aches a bit," she answered Sue's inquiry.

It was aching worse after lunch. "It just *must* let up for that four o'clock train!" she wailed. "If it does n't, you'll have to go alone. I won't let you miss your morning classes."

"I'm a wizard at headaches," Sue assured her. "If you'll mind me now—"

Hilda minded dumbly, and presently the room was dark and Sue's cool fingers were on her throbbing forehead. She hardly knew when Sue began to sing. It was a weird little tune, that rose and fell monotonously. Hilda dozed and woke again. "Sing some more." Obediently, Sue sang in a sweet, low voice that called to sleep.

An hour later, Hilda struggled to her feet. "I've been asleep and missed that train!"

"No, you have n't," Sue assured. "That is, you 've been asleep, of course, but there 's half an hour before the train, and the bags are packed. Here 's your hat."

Hilda took it and ran for the mirror. "Sue," she demanded, coming back, "how do you do it?"

Sue flushed, while she struggled into her own coat. "Sing, you mean? I wish I really could."

"To-morrow," said Hilda, briefly, "you 're going with me to Professor Harlow, and we 'll see if he thinks you 'really could.' But I did n't mean that. I meant, how do you—" the right words would not come. With a little cry, Hilda caught Sue close in her arms. "Sue Hubbard, I feel this minute as though I knew you better than all those hundreds of people up at college. How do you do it?"

"Do what?" puzzled Sue.

But Hilda only laughed. "Now we 'll run for that train."

Back in her own room, Hilda answered questions wildly. "Yes, I had the best time I 've had in years!"

Jo perched on the desk. "Zanne 's furious. She skipped a ballgame to come over here. That note you left on her door—"

"Mistake," said Hilda, coolly.

"Well, Zanne 's furious. Wait till you see her—and hear her! You always did say she had a temper—I mean, a temperament."

Hilda was unpacking. "Any other news?"

"Some more along the same line. That Alice Somebody-or-other was over here when Zanne was and she looked scared to death. She ran away, mumbling something about her fault. You told her to do some-

thing, and she made a mistake. That was all we could make out."

Hilda straightened. "There was n't any mistake. She could n't have done better!"



"THEY CAME IN SIGHT OF A RAMBLING MOUNTAIN HOUSE"

"But you just said there was!" Jo gasped.

Hilda laughed then. "Jo dear, to-morrow I 'll settle with Zanne the Furious One. Right now, I 'm going to 'phone Alice—and thank her. She 'll sleep better if I do."

"Well, if you are n't the queerest person I ever roomed with!"

"I always was," said Hilda, darkly, "but I 'm going to be queerer than ever!"





"HI, BILLY, OUR SUPPER 'S BURNING UP!" HE CRIED"

## THE RADIO MESSAGE

By GEORGE ETHELBERT WALSH

WITH their small portable radio set up and adjusted to receive bulletins from town, Billy Lane and Phil Lawton sat in front of their tent, smiling and absorbed, with their ears covered with pads that gave them a grotesque appearance, while the bacon burnt and the coffee bubbled over. They were oblivious to the sights and sounds around,—the woods filled with singing birds, the murmuring stream at their feet, the majestic mountains off in the distance,—a thing that had never happened before in their five years of camping on the lower fork of Yellow Creek.

It was nearing evening, when musical concerts, lectures, news of the day, and bedtime stories were being spread broadcast on the air, and the boys were listening in, forgetting for the time that they were in camp, miles away from civilization. Their faces were so rapt that they smiled at each other when their eyes met.

The odor of burning bacon and boiling coffee suddenly brought Phil back to nor-

malcy. "Hi, Billy, our supper 's burning up!" he cried, freeing his ears.

Billy did n't hear his voice, but his eyes and nose took in the situation, and with a sigh he cut a concert in the middle. When they had rescued the supper from the fire, they opened up conversation, that had been denied them while listening in.

"Say, that was great!" exclaimed Billy. "It was just like being back home—and we way up here in the woods! Music, concerts, speeches, news—everything!"

"It 's certainly a wonderful thing!" admitted Phil, with equal enthusiasm. "That concert was a peach!"

"And that lecture was worth listening to!"

"I picked up most of the day's news, too, just as if I'd been reading the evening paper."

Billy nodded, and, taking a mouthful of bacon, said: "Did you get the description of that bandit who held up a bank and stole a car for a quick get-away? I could almost recognize him from the description—five-foot-eight, dark hair, small mustache, scar

on left cheek, crooked nose, walks with a slight limp, dressed in brown suit and black cap."

"Yep! And he was headed for the woods," replied Phil. "Wonder if he 'll come out far 's this."

"Don't believe so. Anyway—"

Billy interrupted with a nod of the head. "Did you get the news of the motor-boat *Pelican* that broke its moorings, and the reward offered for its recovery. Supposed to be drifting along the coast. Now if that should come here—"

Phil shook his head and laughed. "Don't think we 'll lay eyes on that any more 'n we will on the hold-up man."

"Why not? The tide sets strong into this cove, and if the *Pelican* drifted this far, it might come in here."

"Yes, it might; but it is n't probable. Gee! I 'm tired! Guess I 'll go to sleep. That radio concert put me in fine spirits. Why, think of it, Billy! Sam Denton and Dan Wilson may have heard that same concert, and they in the city and we way out here in the woods. It 's wonderful!"

"Sure! One of the greatest marvels of the day."

They were both radio fans, and all winter they had been experimenting and working over their machines. When summer came and they left for their camp in the woods, to be joined later by Dan Wilson and Sam Denton, they had made preparations to set up their equipment right there at the lower fork of Yellow Creek. Its success had been so instantaneous that they had cause to be happy and jubilant.

Among the news of the day broadcasted from the central station had been, as we have seen, the report of a bank hold-up by a lone bandit and his escape in a stolen car. The chief of police had sent a description of the man out in the hope that some one picking up the news would see and recognize the bandit. There had also been the news of the lost motor-boat, which had been sent out for a similar reason, the liberal reward offered by the owner being calculated to stimulate the interest of any one on the coast who might listen in.

The boys were still talking in undertones of the music and concert when they rolled themselves up in their blankets for a night's sleep.

"I was dreaming of that concert, Phil," Billy began sleepily, on waking in the morning.

"So was I; but let 's forget it and take a dip before breakfast!" interrupted Phil.

They unrolled from their blankets and prepared for their usual plunge; but in the midst of this operation, Phil suddenly stopped and pointed. "What 's that, Billy?" he asked.

"A motor-boat! Why—why—"

They stared at each other, winking and blinking, wondering if they were still dreaming of the radio messages.

"Do you think it 's the *Pelican*?" Billy gasped finally.

Phil nodded. "It looks like her. Anyway, she 's drifting. We 've got to get out to her quick! Never mind the bath or breakfast. Hustle on some clothes."

They were wide awake and excited. If the lost motor-boat had been caught in the tide of the cove and brought to their very feet, they would have a wonderful day in saving her from drifting on the rocks; and then, with her anchored near by, they could live on her until the owner came down to claim her.

They had a canoe in camp, and when fully dressed they launched it and started to paddle out to the big, palatial motor-boat slowly drifting in on the tide. Half-way to it, however, their enthusiasm was checked a little by seeing another boat, a rowboat, headed for the derelict from the opposite shore.

"I guess we were mistaken," Billy muttered. "She is n't a derelict. There 's the owner rowing out to her."

They rested on their paddles and watched. Phil finally said; "She is n't anchored, and anyway, I believe that man is a camper like ourselves. We must beat him to it. The first aboard a derelict can claim salvage. Paddle hard!"

After that, it was a race for the big motor-boat, the boys paddling with all their might, and the man in the rowboat increasing his strokes as if entering into the spirit of the game. Billy and Phil won, and climbed to the deck of the drifting craft before the rowboat reached the stern.

"Hello!" a voice called to them from below. "What 're you doing on my motor-boat?"

The boys glanced at each other, chagrin and disappointment on their faces. The boat was not a derelict, after all, and the owner was climbing over the stern to take possession.

"We thought she was adrift," Phil apolo-



gized, as the owner came up. "We did n't know the owner was around."

"Well, that 's all right," replied the man, smiling. "I went ashore, and while I was there she must have dragged her anchor. She was adrift. Much obliged for trying to save her."

Billy happened to notice the name *Pelican* stamped on a life-preserver. "Are you Mr. Billings?" he asked.

"Billings! Billings!" the man mumbled, and then nodded his head vigorously. "Yes, that 's my name. But how 'd you know?"

"We got a radio last night," Billy explained, "saying Mr. Billings had lost his motor-boat *Pelican*; and when I saw the name on the life-preserver, I concluded you were the owner."

"Yes—yes—just so."

The man looked surprised and a little displeased. "You say you got that by radio? What 's that? Well, never mind." He stopped suddenly and scratched his head. "Say, by the way, do you happen to know anything about marine engines—how to run them, I mean?"

"Sure!" replied Phil. "I have a little motor-boat at home, and—"

"That 's good!" nodded Mr. Billings. "Come down and have a look at this engine. You see, I generally have my engineer to run the boat, and I 'm not as familiar as I might be with this motor. Let 's look it over together. Maybe you can help me."

The boys were only too willing, and the three went over the big marine motor together. In the end, they discovered exactly how to operate it; and when it started for them, Mr. Billings looked pleased.

"Now that 's fine! I can get back home in it—that is, if I had some one to steer. It 's deuced awkward to steer and run the engine too. It 's too big a boat for one man to control."

Neither Phil nor Billy were anxious to leave their camp even for a short time, but the prospect of running back to town on such a fine boat as the *Pelican* appealed to them and, after exchanging glances, the former said:

"If we could help you, Mr. Billings, we would be glad to go back with you. We could watch the engine, while you steered."

"Just the thing! Now if you 'll do that, I 'll reward you for your help. Where 's your camp?"

They pointed to it on the shore. "Well, now you paddle back there and get what

things you want, and then return. I 'll wait here for you. It won't take you long, will it?"

"No, sir, only about half an hour."

When they climbed back in their canoe, Mr. Billings watched them from the after deck.

They paddled without speaking until they neared the shore. Then Phil turned to his companion. "Billy, did you catch on?" he asked in a whisper.

"Sure! I recognized him first by the scar and then by his limp. He 's the bank hold-up man."

"What 's his game then?"

"Going to exchange his stolen car for the *Pelican*. He must have discovered the motor-boat about the same time we did. He knows people are searching for him on shore, but they won't be looking for him on the water."

"Where 's he left his car then?" asked Billy.

"Somewhere in the woods, I suppose. He had a bag in that rowboat—saw it with my own eyes."

"Then he 'll get away with it?"

"I don't know," murmured Phil. "That was all a ruse, pretending he did n't know anything about marine engines. I saw at a glance he was familiar with them. And he never intended to take us with him. He just wanted an excuse to get rid of us. Of course, he could have knocked us overboard, but it was easier to cook up an excuse to send us away pleasantly."

"Should n't we go back then?" exclaimed Billy, frowning. "We ought not to let him run away with Mr. Billings's boat."

"He won't run away with it right away," replied Phil, smiling triumphantly. "See that!" He held up a small brass pin. Billy nodded, but looked blankly at his companion.

"I unscrewed that from the carburetor when he was n't looking," added Phil. "I don't think he can start the engine until he gets a duplicate of this. It puts the whole motor out of commission."

"Good for you, Phil! That 's fine! But what 're we going to do next? We can't hold him here for long."

"We 're going to our camp," replied Phil, slowly, "and disappear in it. He 'll think for the next half-hour we 're packing up our things to return. That will give us half an hour. When he finds he can't start the motor he 'll get fussed and angry; but he



“NOW,” MUTTERED THE SHERIFF, “HE ’LL GET AWAY BY WATER!” (SEE NEXT PAGE)



won't suspect anything for quite a while. Before that—"

"What?"

"How far is it to the nearest settlement?"

"Anywhere from five to ten miles."

"Well, a good car ought to make that distance in less than half an hour unless the roads are rotten."

Billy blinked hard, trying to follow Phil's method of reasoning and finally asked, "But where do we get the car?"

Phil laughed outright. "Did n't our hold-up man come in a stolen car? Yes? Well, then it must be over there in the woods somewhere. If he has n't wrecked it, I think we can reach it in fifteen minutes. That will give us fifteen minutes to go to the nearest town before our half-hour is up. It 's altogether likely that the man will not grow suspicious for some time after that. He 'll think we 're delayed, packing longer than we said."

Billy's eyes lighted up with excitement. Phil's plot promised success; and when their canoe finally reached shore they were both prepared to act together. They entered the tent, but Phil immediately crawled out of the back part of it and disappeared in the woods.

His plan was to cross the creek, hidden by trees, and run over to the woods to see if he could find the car. If it was there, he was to return in it and pick up Billy just where the road crossed the creek at the bend back of their camp. Billy was, meanwhile, to show himself frequently in front of the camp, making a great show of packing up his equipments.

It was a well considered ruse, and it seemed to work well. The *Pelican* did not get under way. The man was evidently finding trouble with the engine and hunting around for a break in the wiring.

Ten minutes later, the time agreed upon, Billy sneaked out of the back of the tent, and hurried to the meeting-place. Phil was not there, and, growing worried, he started up the road in the direction the car would come. He tramped fully half a mile before he heard the whirring of a motor. Looking up, he saw Phil coming in a cloud of dust.

"Jump in!" he cried, slowing down.

"We 're late! Could n't find it for some time. Then had trouble starting her. Did the man suspect anything?"

"No," grinned Billy, "he was still fiddling with the motor. I packed up nearly everything in camp, and then unpacked them."

Phil stepped on the accelerator and the car leaped ahead. It was a high-powered modern roadster, and they made good time, slowing down only at curves and bad spots in the road.

When they rode into Tomkinsville and related their strange story to the sheriff, a posse of half a dozen men were quickly gathered, and Phil guided the car back to camp. Evidently their man had grown suspicious, for when they reached the spot he was leaving in his rowboat.

"Now," muttered the sheriff, "he 'll get away by water. Tarnation! why did n't we think to telephone for a boat to meet us here."

"I don't think he will," smiled Phil. "There 's our canoe."

"You can't catch him in that skin-boat!" sniffed the sheriff, in disgust.

"No, but once aboard the motor-boat I can start it going in five minutes. You forget about this part I removed from the carburetor."

"Well, I swan, you 're a smart one!" ejaculated the sheriff. "You go out there with two of my men and chase him ashore. I 'll follow in the car and be ready to nab him if he lands."

It was a very much surprised and chagrined hold-up man when half an hour later the *Pelican* bore down on him; and when he attempted to land from his rowboat, he ran plump into the hands of the sheriff. Whether he ever learned the whole truth of how he was trapped, it is difficult to say; but others did, and among them was Mr. Billings, the owner of the *Pelican*. As Phil and Billy modestly disclaimed any desire for a money reward for their work in saving the motor-boat, he sent them a radio set powerful enough to receive messages clear across the ocean. They never tire of using this, listening in to concerts and public lectures whenever possible; but often they smile at their old, discarded, home-made set, and pat it gently as one would an old friend.



### WILL HE DARE?

*Will the bobcat's fondness for fish, which he shares with all cats, large and small, tempt him to spring upon the savage and agile mink? A fresh salmon-trout is an alluring tidbit, and to surprise a mink in the very act of eating one is most tantalizing. But the least move on the cat's part would send the mink hurrying farther up the tree, which he can climb much faster than any cat. The trout might prove too heavy, and be dropped before the chase was over; though the mink, like its small relative the weasel, is very vicious, and would put up a fight for its food. It will be very hard for the bobcat to give up a prize which is almost within his paws; but he will probably rise from his crouching position, stretch in a very leisurely manner, turn, and vanish into the woods.*





The  
 Weaver of Dreams.  
 by Henry C. Fitz, Esq.

THE salt sea-wind is gusting in,  
 With whispered tales of danger-quests,  
 With tales of heaving, foam-flecked wastes,  
 And leaping, white-ringed billow crests.

It curls its moist and salty scent  
 Adown the twisted village lane,  
 And through each shop and raftered  
     house  
 It trails a dream of far-off Spain.

It whispers to the 'prentice lads;  
 Dull merchants sniff, and pale clerks stare.  
 They stop and stir uneasily,  
 Caught in the sea-wind's salty snare.

They see a dimly visioned shore,  
 White kingdoms over lilac seas,  
 A land forgotten of the sun,  
 A coast-line set with pillared trees.

They see strange ships with orange sails,  
 Blue harbors, too, and hill-ringed bays;  
 They hear the soft-voiced foreign speech,  
 The strumming harps, the chantey-lays.

So the tools are dropped, and the looms are  
     stilled,  
 While wonder grows in the teeming brain;  
 And dream by dream the vision grows  
 Of romance on the sunlit main.

Reluctantly, they shake their heads,  
 And finger their accustomed work,  
 And wonder why the brain plays tricks—  
 'Prentice boy and grocer's clerk.

How could they, with human eyes,  
 See where wave and foam begin,  
 The weaver of dreams, as he casts his snares  
 When the salt sea-wind comes gusting in?



# THE WORKSHOP OF THE MIND

By HALLAM HAWKSWORTH

## CHAPTER VI

### THE MYSTERIOUS STRANGERS IN THE LAND OF MIND

SOMETIMES—and I'll venture this has happened to every one—ideas and images come to us which seem as strange and unfamiliar as if they had strayed out of some one else's brain and lost their way into ours! Yet, on investigation, they are found to belong to years of our lives long past, and, apparently, long since forgotten.

Voltaire was once asked if he had any notion of the dwelling-place of these mysterious strangers in the land of mind, and how they could be living, all the time, as next-door neighbors to our every-day thoughts and still be wholly unknown to us.

"Aye," he replied in the words of the poet, "where sleep the winds when it is calm?"

But just as modern weather science has learned a good deal about the comings and goings of the winds that was unknown in Voltaire's day, so modern mind science has found out several things about these unknown guests and their movements, all very interesting and much of it of practical value.

### THE TREASURES STORED IN THE HIDDEN CHAMBERS

FOR one thing, these forgotten memories are usually of matters more or less trivial in themselves,—the big events of life are not apt to be forgotten,—but on their return, these trivial memories often bring to creative minds such a train of new ideas and are themselves frequently so transformed that it is said the creations of genius are largely the upwellings of the unconscious.

Let us look around a little in the hidden subtreasuries of the mind from which these things come. Here also, in the regions we are now exploring, it is our good fortune again to meet Professor Bergson. When we ask him about the return of these mysterious strangers from our yesterdays, he tells us that he shares the opinion of many other psychologists that the whole of our past life is preserved in our memories, although ordinarily we are so little conscious of the fact.

"Yes," he says, "even to the smallest details. Our memories, at any given moment, are like a pyramid of which we are conscious

only of the apex. For every memory concerned in our daily occupations, and of which we are conscious, thousands of memories are stored below, of which we do not even suspect the existence."

### HOW MRS. PIPCHIN WALKED INTO "DOMBEY AND SON"

DICKENS, as the result of his own experience as a writer, said he believed the impressions of childhood remain hidden in us all our lives. He found that, like other writers of fiction, he was constantly drawing on this savings-bank which he unconsciously started as a little boy. When "Dombey and Son" first came from the press he sent a copy to his sister.

"What does this mean?" she wrote, "In *Mrs. Pipchin* you have painted our old lodging-house keeper to the life, and you were only two years old at the time!"

Many of his story people, Dickens drew consciously from models of his own choosing; but the lodging-house keeper walked in as an entire stranger and turned into *Mrs. Pipchin* while he drew her portrait—wholly unaware that she was a memory of his childhood. And *Little Nell*—perhaps she, too, was a fond recollection of his early days at school.

Most of the characters that you meet in the works of the masters of English fiction had originals in real life, but many were unrecognized by the writer until he had reincarnated them by the magic of his pen. Of Scott's work it was said there was hardly any one he had ever known of whom his memory had not treasured up something that helped give reality to the people of his fancy.

It is seldom, however, that any character, complete and without change, is thus transferred to the written page. One character of fiction will be a composite of the characteristics of a dozen people known to the novelist in real life.

One of the most curious things about the reappearance of these residents of the hidden mind is that sometimes, after coming back into the light and having their pictures taken, they go into hiding again! They again vanish from the consciousness of the very mind in which they live. Thackeray, in



looking over back numbers of "Pendennis,"—like many other works of fiction, it first appeared as a serial,—found passages which he had as utterly forgotten as if he had never written them. When "The Bride of Lammermoor" was first put into Scott's hands in book form he did n't remember one single incident, character, or conversation. This kind of thing has even gone so far that novelists, after having killed a character earlier in a story, have resurrected him in a later chapter—just as Mr. Riley's little *Bud* did in his story of the bears.

But these creatures of the brain are as real to the novelist, while they are before him, as children of flesh and blood; and often as wilful. Scott says, in his introduction to "The Fortunes of Nigel," that his plots and plans were constantly overridden by the characters themselves. And Dickens declared:

When I sit down to write a story some beneficent power shows it all to me as I go along and tempts me to be interested. I don't invent,—really do not,—but see it and write it down.

"What, you ask, is my method?" wrote Mozart, in answer to an inquiry. "I do not myself know. When I am feeling particularly well and in a happy mood—perhaps in a carriage or while taking a walk after a good meal—thoughts come to me. Often during a sleepless night they come to me with a rush and best of all. All the finding and making goes on in me as in a very vivid dream."

It is on such experiences as these, among other things, that the superstition of "genius" has grown up; that is to say, of genius as something entirely different in its character and working from the ordinary mind. In the case of genius, it is called "inspiration"; in the case of ordinary mortals, it is called "getting an idea."

There are many authenticated instances going to show that the memories of every one's past are stored away and that, under certain circumstances, they come back. It is well known, for example, that people undergoing the experience of drowning and afterward being revived see their whole past as in a dream. A vestryman of the Episcopal church told me that he had had this experience three times in his life and that the vision itself was very pleasant.

Since the subsoil of our mental gardens has this remarkable faculty of absorbing everything, quite independent of our efforts, don't you see how it emphasizes the importance of the question of the kind of company we keep, either in the way of people or books?

TEACHING THE STRANGERS HOW TO WORK AND whether our submemory deposits are put to useful purposes depends on another thing. If the conscious mind forms the habit of "mulling things over," the subconscious workers—what Stevenson called his "brownies"—will, so it seems, frequently go on with the mulling, wholly unknown to us, and, when they have arrived at a conclusion, come up and hand it over! It was because of this that when Dickens sat down to write, some "beneficent power" showed it all to him, as he went along. In the language of a distinguished psychologist, "This unconscious self, like a benevolent stranger, works and makes provision for our benefit, pouring only the matured fruits into our lap."

It is quite as if these unknown guests, these benevolent strangers, met in "executive session"—all reporters excluded—and discussed questions of state or painted pictures or worked out problems in mathematics or untied knots for the lawyer or, like the board of directors of a corporation, passed upon business problems and gave the results to the conscious self. Have n't you often gone to bed in a state of puzzlement over something—in arithmetic or algebra, say—and awakened next morning with the solution all worked out in your head?

"Well, I'll sleep over that and give you my answer in the morning," is often the reply of the business man to a proposition that he can't just see his way through at the time.

"Night," said Napoleon, "is a good counselor."

"WAKE UP! WAKE UP! YOU 'VE MADE A MISTAKE!"

AND sometimes these counselors on the "night shift," after discussing the conclusions of the day counselors, refuse to "concur," as we say when the Senate takes similar action in regard to a bill passed by the House. Then this deliberative body of the night may wake Mr. Man up and tell him so, in cases where something has got to be done and done quickly. That is what happened to the sales manager of a certain large business concern. He dictated a letter to one of the men on the road quoting prices on a transaction amounting to something like a quarter of a million dollars; it was well over \$200,000, anyhow. The prices were only about half what they should have been, owing to a mistake in his calculations. But

wholly unconscious of his mistake, he went home, and, after a very pleasant evening during which he dismissed all business matters from his mind, he went to bed.

certain people, being stimulated to special activity by newly awakened interests—the appetites of the conscious mind; much as the subconscious action of the stomach is stimulated when we eat.

Fromentin, the French painter, poet of the Sahara, who developed a remarkable memory for form and color said:

The longer a thing is held in my memory, the more it is changed and the more valuable it becomes for the work I intend for it. In proportion as its exact form becomes altered, another form, partly real, partly imaginary, and at the same time more useful for my purposes, takes its place.

These are the words of Fromentin. But do you read something else between the lines? You will notice in the third paragraph above this, I said the process of digestion takes place in the minds of "certain people." Now I'll tell you who these certain people are. They are the people who think about how to improve themselves and their work. In this way they educate the subconscious mind to help; teaching it to go on with things even when the conscious self is asleep or at play or spending its pleasant evenings at home. The process is very suggestive of the way in which we educate certain "little brains" referred to in



TWO OF DICKENS' CHARACTERS—THE SCHOOLMASTER AND LITTLE NELL

At one o'clock in the morning he awoke suddenly with a vivid realization of what he had done and promptly telegraphed the salesman to whom the letter had been sent.

This process of digestion of ideas—to modify our metaphor of deliberative bodies—apparently goes on all the time in the minds of

Chapter III—the ganglia that control the legs, for example. When we take our first steps in this brave new world of ours, it requires a good deal of attention and practice to make even the short excursion from one chair to another, or from Mother's arms to the outstretched arms of Aunt Helen; but in time



these same legs get so that all we have to do is to tell them where we want to go and they take us there, the brains in the head, meanwhile, dealing with other matters connected with the journey.

So it is with the subconscious workers in minds with a purpose. (Notice Fromentin's phrase, "for my purposes.") But it is quite otherwise with minds without a purpose. They may do a lot of idle reading and take part in much idle talk and remember it almost word for word, but when they reproduce this talk what is there in it but a tedious series of "Sez he's" and "Sez I's?"

"It is a very great error," said Mozart, "to suppose that my art has been easily acquired. I assure you there is scarcely any one who has worked so hard at the study of composition as I have." This constant study and practice of any art, including the art of successfully conducting any business or profession, not only increases facility in thinking and skill in execution, but it furnishes leading and commanding thoughts that rule the people of our subconscious world.

#### "THE STRUGGLE OF LIFE" AMONG OUR IMAGES

AND just as in the world outside the brain, there is the constant struggle of life and the "survival of the fittest," so there is a struggle of life among the image people, the idea people, in the brain and a survival of the fittest—in the sense that the ideas survive that fit in best with whatever is our uppermost interest at the time. Taine puts it this way: "In the struggle of life in which all our images are constantly engaged, the one furnished with the most force treads down its adversaries."

Now, in this very situation—these wrestling-matches of rival memories, ideas, and tendencies in the brain and the victory of those to whom we give a helping hand—comes our great opportunity for self improvement and for "being somebody," as Lincoln's good stepmother said to him—finding our place and service in the world. After all, there is nothing so easy to change as one's mind. Have n't you changed yours many a time? This was in small matters, perhaps, but larger and more permanent changes only require a little more effort, a little more time.

You have heard Mr. Burbank spoken of as "The Plant Wizard," because he has changed black blackberries into white blackberries, taught the cactus to give up its thorns, doubled the size of potatoes, put new per-

fumes into flowers—things like that. And do you know how he did it? What the magic of it was? He simply set vast numbers of plants—blackberries, for example—growing in his nurseries and kept selecting and crossing those varieties, that by "spontaneous variation"—as the result of some mysterious struggle of qualities in the plants themselves—produced the qualities he wanted. He also crosses plants, of course, to combine desired qualities.

"I introduce color here," he says, "shape there, size or perfume, according to the product desired."

And he offers the following arguments, from his long experience, to show that the human plant is capable of similar treatment and results—more capable:<sup>1</sup>

A great force is necessary to change the aspect of minerals and metals; powerful acids, great heat, mechanical force. Less potent influences will work a complete change in plant life. . . . When we come to animal life, especially in man, the influence necessary to effect a transformation is extremely slight, . . . nurture, proper surroundings, selection, the separation of the best from the poorest. . . . Before all, bear in mind repetition, the use of an influence over and over again. This it is that fixes traits in plants—the constant repetition of an influence until it becomes irrevocably fixed and will not change.

All of which is very important business in the changing of plants; and still more so in the changing of one's mind. As Mr. Burbank says, "You can't afford to get discouraged." Sow the best seed you can get and keep selecting and selecting.

A phase of the working of the subconscious mind which no one has yet explained is that of persons who, with no previous training or knowledge, can solve problems in arithmetic and that almost instantly. Often these prodigies are mere children. A boy named Zerah Colburn could do such things at the age of eight. Being asked the square root of a number,—106,924, for example,—he answered, before the number could be written down, "327."

"What is the cube root of 268,366,125?"

Back came the answer, "645"—quick as a wink!

"How many minutes are there in 48 years?"

Again, before the question could be written down, came the answer, "25,228,800." And Zerah added, "The number of seconds, sir, is 1,513,728,000."

No end of things like that! It was apparent from the motion of his lips that some kind

<sup>1</sup>The Human Plant. The Century Co.

of calculating process was going on, but the boy could give no account of it. It was evidently very different from the methods we learn at school and which all of our great mathematicians employ.

Such cases as that of Zerah Colburn fulfill exactly the popular conception of a genius as one who gets results in quick and mysterious ways. But the methods of men who become great are quite the reverse. Zerah, on the other hand, did not grow up to be a distinguished mathematician; and this is true of all similar prodigies. Their performances are interesting as showing the capacity of these hidden other-selves of ours for doing marvelous things, but great men in all lines have achieved their results by the same methods used by ordinary men.

These great men often say, to be sure, that they do not know how their ideas come, but this simply means that they are so much more interested in the result than the process, that they can't remember. But the circumstances all go to show that they raise better things in their subgardens than most people do because they planted good seed and were better gardeners.

Another thing in regard to achievement ought to be spoken of here, I think, and that is that the mind of what we call the genius works best in an atmosphere of modesty. This statement may seem unwarranted when we recall that so many great men have been far from modest. A certain eminent French author, for example—one of the greatest men in the history of French literature, perhaps

—carefully preserved the pen with which one of his books was written; "for," said he, "posterity will value it as a souvenir." But remember he said this after working-hours.



THE ARAB FALCONER—FROM A PAINTING BY FROMENTIN

Like all other men, the genius does his best in proportion as he is absorbed in what he is doing—forgetful of self; the more his work approaches the conditions of the subconscious, in other words.

"Shakespeare," says Carlyle, "takes no airs for writing 'Hamlet,' and 'The Tem-



pest' understands not that it is anything surprising."

Coleridge, it is true, said Shakespeare "was not unaware of his greatness," and considered the sonnets as abundant proof of this. Such lines as:

Not marble, nor the gilded monuments  
Of princes, shall outlive this powerful rhyme.

But investigation in recent years shows that, in saying such things, Shakespeare was merely following a style of expression that was in vogue at the time. Fashion in dress, you know, is responsible for all sorts of queer things; and this is also true of the history of the styles in which men have dressed their thoughts. It is hard to conceive that a man so well balanced and who was so entirely free from vanity or egotism in his relations with his fellowmen, should have seriously indulged in this kind of boastful self-advertisement. It seems highly probable that he wrote such lines as those quoted in a spirit of good-humored mockery at this very practice; as when in the play upon his own name, "Whoever hath her wish, thou hast thy Will," he is known to have been mocking the wire-drawn conceits of brother sonneteers. His references to his growing "age" are known to have been written when he was only about thirty! It was Petrarch who set the fashion of assuming old age to give the proper atmosphere to certain verses, and later poets used the same device for the same purpose.

#### CAPRICIOUS WAYS OF THE MYSTERIOUS STRANGERS

IT is true, as Ruskin says, that all great men "not only know their business, but usually know that they know it. Yet they often have a curious undersense of their powerlessness, feeling that the greatness is not *in* them, but *through* them"—this on account of the more or less capricious action of the "mysterious strangers" we have been talking about. These strangers are most apt to return during periods of mental excitement, and those that come are related in their nature to the things one is excited about.

But yet, while they come in periods of emotion,—these mysterious strangers,—they also come in periods of perfect calm; they come when the mind is vigorous and active, but they also come when the mind is tired; when we make efforts to recall and combine thoughts, and when we give up making any effort at all. In the latter case, it is as if the idea you are looking for were

playing hide-and-seek. When you give up, out it steps, as much as to say:

"One, two, three for me! You had a hard time trying to find me, did n't you? But was n't it fun?" Just as friendly!

And speaking of friends, have n't you often noticed how, in the very act of telling a friend of something you could n't understand, the answer popped into your head before he could speak a word? You say, "What I don't understand about it is this—"

Whereupon the answer to this "this" makes its appearance, like a deferential butler in his swallow-tailed coat—"Excuse me, sir, did you ring?"

In all these sudden returns of forgotten memories, the law of association evidently plays an important part. The psychologist people say this is because things that come into the mind together are apt to remain connected, the brain-cells in which they are "stored" being joined together by little pathways called "synapses," from a Greek word meaning "union." So the activity of one cell tends thereafter to excite the others; much as when we get something in one eye, the other wants to cry about it!

But after all, this explanation does n't go much beyond the reply of the old colored attendant at the dining-room door at the hotel, when Dr. Eliot of Harvard asked him how he could remember peoples' hats so well and always hand back the right one to the right man.

"How did you know this was my hat?" asked the doctor—at least so the story goes.

"I did n't know it, suh."

"Then why did you give it to me?"

"Because you gib it to me, suh!"

#### YOU NEVER CAN TELL TILL YOU TRY

THE great practical fact for us is that the brain has this remarkable faculty and that in the land of mind, as in the land the farmer tills, there are untold possibilities in the subsoils, if we only cultivate them in the way the lives of men teach us to cultivate them—by industry, by enthusiastic interest in our work, by singleness of purpose. Listen:

"It seems to be accepted," [says Ribot] "that genius depends on the subconscious imagination, not on the other, which is superficial in nature and soon exhausted."

These are the deeps that lie below the old and true saying, "You never can tell till you try!"

An inspiring thought, is n't it?

# TAKING A HINT FROM HANNIBAL

By MERRITT P. ALLEN

UP one street came the small, stooped, gray-haired principal; up the other, a tall, deep-chested, blue-eyed junior; they met at the corner and fell into step toward the high-school building.

"Congratulations!" the principal said heartily. "I hear you have been elected to fill Barnes's place. Congratulations!"

"Thank you, Mr. Greene," the boy said with some embarrassment.

"You deserve the honor, Stanley."

The boy flushed a little. "I feel that there is not much honor in being captain of a high-school baseball team," he said. "The captain is no different from the other men."

"That is true in a measure," Mr. Greene agreed. "He plays the game under the same conditions, the same rules govern him that govern the others; but in addition, he carries the responsibilities of his position."

"I never thought that a captain had much responsibility," Stanley said. "Of course, if there is any kicking about decisions and things like that he represents his team; but aside from that, there is no special responsibility, is there?"

The little principal looked thoughtfully up over his glasses. "I think there is," he replied slowly. "You recall that the word captain is derived from the Latin *caput*, meaning head. The head directs and to a great extent is responsible for the actions of the body under it. It seems to me that, as we are too poor to have an athletic director, you are decidedly the head of the Milton team. Yes, Stanley, I think that you have a real responsibility."

The boy looked concerned at this. "But, Mr. Greene," he said, "you don't mean that the winning or losing of a game—the Auburn game, for example—depends more on me than on the others. I can only play my position."

They were at the school-house steps and the principal stopped and laid his hand on Stanley's arm.

"You now have two positions to play," he said earnestly, "second base and captain. The first you can play only occasionally, but the second you must play constantly. A captain leads his men in battle; but he should lead them no less in peace, or, when the next battle comes, they may fail. Do you see what I mean, Stanley?"

"Yes, sir; I think I do. Thank you," the captain answered.

And the more he thought about it, the more he became convinced that he did have a real responsibility. He did not take it too seriously, but he saw his position in a different light than did the others. When Barnes,



"DO YOU SEE WHAT I MEAN, STANLEY?"

the captain, left school in November, and the members of the Milton team assembled to elect his successor, no one thought that they were choosing a leader. A captain was necessary, and they put in Stanley because he was a good player and a good fellow—that was all there was to it. There, as in most schools, the captaincy of a team was a reward for athletic ability and all-around popularity; leadership, in the true sense of the word, was not considered.

But Stanley's conversation with Mr. Greene had opened his eyes. It had given him no inflated opinion of his own importance, for he was a sensible chap, but it did make him feel that the team's showing next



season, especially in the Auburn game, depended a little more on him than on the others. Auburn was Milton's deadliest enemy in sports, and that was *the* game. Formerly, it had been nip and tuck between these two high schools; but for the past five years the laurel had gone to Auburn because, so it was said, a wealthy Auburn alumnus had



"I THINK YOU 'RE AWFULLY NICE, STAN"

given his school a gymnasium, where the boys kept fit during the winter and thus had the jump on their rivals when spring came. Milton could not match this. In spite of themselves, her men became soft in the winter; and in the spring, having no regular coach, they rushed headlong into practice and half of them injured their arms at the start. This meant a loss of form that they could never recover in time to down Auburn. The last game had been lost 8 to 1—the worst ever.

Stanley's newly awakened sense of leadership told him that he must do something to remedy this condition of affairs; but it did

not tell him what to do. In fact, there seemed very little that he could do. They needed a gym and a coach, but he could not build the one or be the other. He thought of a dozen plans, and one after another they failed. It seemed inevitable that they must drift along in the same old way and go down under the Auburn avalanche next year.

During the mid-year vacation, Stanley spent a day in Auburn on a small business errand for his father. School was in session there, to make up for a week lost earlier in the year on account of an epidemic; and having an hour to spare in the late afternoon, he went up to the gymnasium to renew acquaintances. Being such intense rivals, the Auburn and Milton boys were, of course, the best of friends, and Stanley was hailed joyfully. At last, Cash, the Auburn captain, took him in charge, and they strolled about the building. For the most part, it was as quiet as a class-room; a few boys were reading, several were purely loafing, and four were playing pool. In passing, Stanley took a turn at the rings and horizontal bars, and found, to his surprise, that they were covered deep with dust. The punching-bag was soft and the wrestling-mat was rolled up in an out-of-the-way corner.

"How many hours a week must a fellow put in here?" he asked.

"Oh," Cash answered carelessly, "there's no rule now. Each does as much as he likes."

"Who is the director?"

"There is n't any, exactly. The prof is supposed to be, but he does n't show up once a month. It's our fault, I suppose, for we don't back him up as we might. What's the use this early in the season?"

Nothing more was said about it, but Stanley had been deeply impressed. It was plain as day that the Auburn boys felt no need of physical training. A long string of victories had made them confident, and they were resting on their laurels. Their unintentional air of superiority, had galled Stanley and made him more determined than ever to lead his team to victory.

The next day at noon he stood on the post-office steps with Phyllis Adams, a junior, reading a poster advertising a sleigh-ride to Tucker's Pond and a skating-party there that evening for seventy-five cents.

"I think you're awfully nice, Stan," Phyllis said, jokingly. "Take me, won't you?"

"Delighted!" Stanley agreed. "All you need do is furnish the money. I'm broke."

"That would be easy for me," Phyllis

said, "but the way to appreciate money is to earn it yourself."

"How, for example?"

"Well, let me see. Oh, yes; Mr. Brown wants help rolling logs down at the mill."

She turned to a man who was just emerging from the office. "Don't you, Mr. Brown?"

"Don't I what?" he asked smiling.

"Don't you want a bright young man to learn the log-rolling business?"

"I want all the men I can get, young or old, bright or dull," Mr. Brown said. "We are buried under logs down at the mill."

"There 's your chance, Stan!" Phyllis cried delightedly. "And be sure to pay him a dollar and a half to-night, Mr. Brown, the price of two tickets." And she was off down the street, laughing.

So it came about that Stanley rolled logs that afternoon for five long hours. He came up the hill in the twilight more tired than he had ever been in his life. Every muscle in his body ached, and the mere thought of skating made him groan. He had his dollar and a half, but not the slightest desire for more action that day. So after supper he called up Phyllis and told her that he was dying from overwork; and she, saucy as ever, replied that it made no possible difference to her as there were then three boys in the parlor drawing lots to take her. He sent his heartiest thanks to the three, and stretched out in a Morris chair by the living-room table, where his sister, a freshman, was studying her ancient history.

"Where are you at now, Sis?" he asked idly.

She looked up, glad of the interruption. "The Second Punic War," she said, "at the place where Hannibal won the battle of



"'FELLOWS,' HE CRIED, 'THEY ARE LAUGHING AT US BECAUSE WE ROLLED LOGS'" (SEE PAGE 1145)

Cannæ and then spent the winter in Capua. What a blunder he made!"

"I always thought Hannibal was rather brilliant."

"Oh, of course he was. But he was stupid, just the same, to relax and let his army get soft in that luxurious city. He was so cocksure of winning the war in the spring that



he did n't think it necessary to keep his men fit. That 's why, though he won victories later, of course, he did n't promptly follow up his success at Cannæ, and eventually lost the war. But all that winter after Cannæ, while he was loafing, the Romans were hustling and strengthening themselves; and they won in the end."

"Do you think that is always the case?" Stanley asked, sitting up.

"Certainly, when one side loafs and the other side works, there is no doubt about the outcome," she said wisely.

"Thanks," Stanley said simply, "you have given me an idea, Sis."

The following Monday after school he called the team together.

"Since you fellows elected me captain," he said, standing beside Mr. Greene's desk in the assembly-room, "I have been trying to think up a way by which we can make ourselves less of a joke this year. And I think I have it. Last week I was in Auburn. The fellows there are so sure of trimming us that they are n't trying to keep in shape. Their gym is nothing but a club-room. They are taking it easy like the old Carthaginians in Capua. After they licked the Romans at Cannæ, if you remember, they were so dead certain of winning the war the next spring that they went in for a good time the whole winter long in the city. But the Romans did n't loaf or spend their time mourning over what had happened; they made every minute of that winter count; so instead of the Carthaginians winning the war, they finally lost it.

"Now, then, I propose to take a tip from the Romans. The Auburn team are the Carthaginians—they are loafing in Capua this winter. Their gym is covered with dust; they are soft. We have a gym right here in town that is better than theirs, for you can't loaf in it—it is the mill-yard.

"It 's no joke," he continued, when some one laughed. "Last week I rolled logs there for half a day; and believe me, I got all the exercise I wanted and then some. My arms, legs, back, lungs, heart—every part of me worked hard. If I followed it up, I'd be hard as nails before spring. What more could a gym do for me? Nothing.

"That half-day's work gave me an idea. I saw the mill foreman, and he will be glad to take us on every afternoon for two hours for as long as we want to work. If ten of us will work for him until time for spring practice, then he will let us have one of

his office-men, Jim Campbell, the old Yale short-stop, to coach us the entire season. That will be our pay.

"Now, fellows, it 's up to you. If you care enough about victory to work for it,—*work for it*,—come on. In two months' time we 'll be as fit as though we had trained in a million-dollar gym; and when the season opens up, we will have the best coach in the State. But if you are too lazy to try, if you don't care enough about the school to sweat and ache for it, don't you dare whine when we get licked! What do you say?" He waited with flashing eyes.

There was a moment's silence, then, Morse, the big catcher, cried: "You 've got the right talk, Stan! I 'm with you. Come on, fellows, buck up and back the captain."

They did. They followed him to the mill-yard that afternoon, and five afternoons a week thereafter. At first they went because it was understood that a quitter would stand no chance of making the team; and later, because they saw the result of their work. To be sure, hands were blistered and muscles ached wickedly; but Jim Campbell came out of the office occasionally to see that the thing was not overdone, and, under his inspiring direction, peavey, pine logs, and keen air built up more and better muscle than any gym. When the boys felt themselves hardening under the work, they became enthusiastic and needed no more urging.

In the spring they threw themselves into baseball practice with a whoop, as you might say. Their optimism had kept pace with their physical advance, and they were confident of victory for the first time in two years. Virtually no time was spent in building up; almost from the first, Campbell had felt safe in working them hard, with the result that the opening game found them in mid-season form.

They progressed like a whirlwind, upsetting everything they met. Five games were as many victories. Auburn, with all her confidence, became anxious and sent a scout to fathom her rival's tactics. His report was not comforting to those who sent him—that Campbell had a machine that worked as smoothly as a college team.

"You ought to see 'em!" he exclaimed, with generous enthusiasm. "Those gawky children we ran away with last year are hard as iron. I saw Walden shoot one from center to the plate as easy as pie; and Stanley's home run did n't wind him any

more than walking across the street. The whole team seemed as fresh in the ninth as in the first." And he concluded, referring to their method of training, which was becoming famous, "We have got to dig as we never did before if we beat that bunch of lumberjacks."

Auburn did dig. All the men were made of the right stuff, and during the next six

score. Neither could Auburn increase her lead; but she held it.

The first man up in the ninth was Dorr, the Milton right-fielder, and he struck out. "That was easier than rolling a log," some wit shouted, and the crowd roared.

Stanley, already at the plate, took up the challenge. "Fellows," he cried, "they are laughing at us because we rolled logs.



"AS THE CATCHER RAN UP TO IT, STANLEY FLASHED BEHIND HIM—SAFE"

weeks each one came back with all his old-time pep. They had a wonderful season, which would have attracted more comment had it not been exactly matched by Milton; when the teams faced each other in June, each had played ten games and won ten victories.

The game was played on Auburn soil, and the field has been famous ever since, especially to those who saw the battle. Auburn scored three times in the first four innings, and Milton scored not at all during that time. "We 've licked 'em!" exulted the Auburn crowd; "we 've licked the lumberjacks!" Only the scout shook his head doubtfully. "If they catch up," he said, "and it comes to a test of endurance—"

But the visitors seemed unable to catch up. In the sixth, they pushed a man around to third; and in the eighth, they got three on bases and none out; but they could not

We 'll show 'em that it paid. Come on, let 's go!"

And they did go—three times around the bases before they could be stopped. It was a magnificent rally and tied the game 3 to 3. In the last half, their defensive work carried the game into the tenth inning. The scout was on his feet with the others, but his heart was heavy, for the test of endurance that he had feared was at hand.

Jim Campbell, with his mass of baseball knowledge gathered at Yale and elsewhere, sized up the situation and passed the word around to his team: "Keep them from scoring, at any cost. No matter if you don't score for a while. Sit tight, and they will break first."

There is no settling down to fight out the extra innings of a game. Spectators and players are keyed to the highest pitch, for the teams are locked in a clinch that can



only be broken by victory, and victory at such times hangs on a thread. A hit, a fumble, a wild pitch—and the battle is forever lost. It is the knowledge that the spectacular finish may come at any moment that makes the excitement so intense. That game was no exception. The tenth, eleventh, and twelfth innings flew by. No one had sat down since the ninth; even Mr. Greene, who had started the game on a comfortable seat in the shade, was now close behind the Milton bench, bareheaded, frantically pleading with his boys to "eat 'em up!"

Those who had expected Auburn to weaken first had been disappointed thus far; though, in the thirteenth, there was an instant when things looked black for her. Her pitcher, Ingham, who had played a splendid game, was touched for a single by Walden, who went to second when the catcher dropped the next ball, and a minute later reached third by a thrilling slide. One batsman struck out; another went out on a pop fly to first; then Gray, the heaviest Miltonian, put all his weight into a stinging drive between third and short. To stop it would be about like stopping a cannon-ball, but little Flagg, the Auburn short-stop, did not hesitate. He put out his bare hand, there was a wicked smack, and the ball dropped to the ground. He scooped it up in his glove and tossed it to third in time to catch Walden off. Flagg's hand was swollen for days, but he was a hero. The score was still 3 to 3.

To the crowd, Auburn seemed as strong as her opponent in the fourteenth inning; but Campbell saw differently. When the Auburn men came in from the field he studied each one carefully and found that, though they did not realize it, they were weakening. The pitcher's arm trembled slightly as it hung by his side, the fielders unconsciously stood with their hands on their hips to ease their aching back muscles, and weariness lurked in every eye. The strain was telling. Campbell looked at his own men and, while they were by no means fresh, he saw that they had some reserve strength.

Auburn was retired, and, before the fifteenth inning opened, Campbell gave the order to hit and run, run wild, take chances, make a supreme, desperate rally. Stanley, the first man up, leaped to the plate like a tiger, swung with all his might at the first ball, and knocked a clean single to right-field. He got the signal to steal, and was off while the pitcher was winding up. He

was not the fleetest man on the team, and earlier in the game might have failed; but the catcher, arm weary and a little less alert now, hesitated for a second, and in that second the Milton captain was safe. Gorton was at the plate, dancing and swinging his club like an Indian. The whole team seemed to be strung on wires, bursting with energy; Auburn appeared suddenly slow by contrast. Gorton drew a ball and a strike, then sent a twisting grounder a little inside of first, and followed it, yelling like a madman. The first baseman fumbled, recovered too late to put out the runner, and threw to third; but Stanley was already there, having started at the crack of the bat. And Gorton, who was a jack-rabbit to run, was half-way to second—he was there—and no effort had been made to stop him. The inevitable break, that time when mind and body can no longer cooperate, was coming, and it had hit the third baseman first.

The pitcher knew it, but heroically he faced the next batsman, Haynes. Haynes was a poor hitter, and after two strikes he popped one square into the hands of Bird at second, and Bird dropped it. Stanley was away from third like a shot and tearing for home, taking a desperate chance. Bird recovered the ball and heaved it at the plate; but it fell short, and as the catcher ran up to it Stanley flashed behind him—safe!

Milton 4. Auburn 3.

Then the break came. Confused, the catcher threw to second, where there was no runner, for Gorton was already at third and Haynes was holding first. Bird pegged to third, third fumbled, recovered, forgot his own man at sight of Haynes nearing second, and pegged back. Haynes was safe and Gorton nearly home. A wild throw to the plate. Another score for Milton. A nightmare of unreasonable errors for Auburn.

Finally, the pitcher, still fighting gamely, got the ball and held it; but all chance of victory for the shattered Auburn team was gone. In a pandemonium, the inning was played out some way and the game ended. Milton 7. Auburn 3.

"The result of skilful coaching and splendid physical endurance," the newspapers said next day.

"But," Jim Campbell modestly pointed out in a speech at the victors' banquet, "you would have had neither the coaching nor the endurance if your captain had thought that the war was lost after Cannæ. Three times three and a tiger for Stanley!"

# THE STORY OF THE TROLLEY

By T. COMMERFORD MARTIN

TEARFULLY, but bravely, the young wife handed to her boyish, inventive husband "Tom" the silk dress in which she had been married only eight years before. He needed it for insulation! It had been carefully folded away in lavender by the beautiful bride when, in 1827, Thomas Davenport, the active, but studious, village blacksmith of Brandon, Vermont, had so far forgotten his profound interest in the "galvanic magnet" of Joseph Henry as to fall in love and "settle down." Only a few miles away, Professor Henry was making, at the Albany Academy, his immortal discoveries in electromagnet induction and the principles of the telegraph; and one or two of his novel magnets had been taken to the Penfield Iron Works, near historic Ticonderoga, for sifting magnetic ore. Rumor in those rural districts even had it that such magnets could hold up an anvil, like Mahomet's coffin, twixt heaven and earth, and that dreaming blacksmith felt he must see it and get one. But trade at the Brandon forge was brisk, a little family began to grow up around it, and even a brick home was built. Going across Lake Champlain to Penfield one day, in 1833, to get iron needed in the shop,—though it could have been obtained nearer his village,—poor Davenport yielded again to the charm of those wonderful magnets. Their spell was so strong that he took the pitiful little eighteen dollars that he had brought with him to buy iron, and carried back instead an electromagnet and some batteries to excite it. How much more he needed that cheap little equipment! Impatient customers with broken buggies and lame horses might wait angrily around his door, while he, forgetting the smithy, handled the mysterious magnet reverently, a humble worshiper at the shrine of Nature's secret. "Like a flash," he says, "the thought occurred to me that here was an available power which was within the reach of man."

Yes, it was there, and his was the superb insight of genius to detect that brand-new fact. He was another Saul hunting for his father's strayed asses and finding a kingdom—another of the immortals selected in some superhuman way to be leaders of the human race—the power bringers.

Within a year, still neglecting his smithy

business, Davenport had built his first electric motor and discovered "the production of rotary motion by repeated changes of magnetic poles," which could be applied as a "moving principle for machinery." His patent of 1837, the first of its kind in America, set all this forth, so broad in its claims that it was said, in 1891, forty years after the patent had run out, that "if it were in force to-day, upon a fair judicial construction of its claims, every successful electric motor now running would be embraced within its scope."

Possibly by reason of poor insulation, the first little Davenport motor of 1834 did not work very well. Funds were fading away; nevertheless, another motor must be built, so into its insulation, around the tiny coils of wire, went the narrow strips of the delicate wedding-dress. From that time on, never again was Davenport to know peace of mind nor was his family to enjoy a quiet home of comfort. It is a pity that loyal Emily Davenport did not live to see how, in these later, happier years, the successors to her husband, by way of noble amends, have brought in countless little electric motors to relieve the burden of drudgery in the household.

Just about this time, Jacobi in Russia had begun also to obtain rotary motion from electromagnets; and in 1838, with the help of the Czar Nicholas, he propelled a small boat on the Neva at St. Petersburg. But meanwhile, Davenport was already employing the first "commutator" on his 1835 motor; and next year he made the memorable advance of building both motors and tracks, to show that a railroad could be run quite as well by electricity as by steam. Davenport was ever as full of ideas as he was short of money; and as one of its early passengers and critics, he had seen the pioneer steam railroad at work since 1831 between Albany and Schenectady. It would seem that he even talked over electric traction with the great Henry, who kindly warned him to go slow when he proposed to build motors up to a size of one horse-power in his competition with steam. Anyhow, when his native State, Vermont, had not one single mile of steam railroad, Davenport, all fire and enthusiasm, built his curiously prophetic little model of an electric road and boldly asserted that such was the better way to do it.



The car was shown traveling on a circular track twenty-four inches in diameter. It depended for "current" on primary batteries, —a dynamo for electric energy not then being available. The batteries were placed on a tray at the center of the circle, with contact through mercury cups; and thus was at once foreshadowed the central power-house idea of modern operation. Moreover, just like the cars of to-day, those primitive cars used the track for the return circuit; besides which, the motors were "shunt wound." Beyond all this, to raise capital for expensive trials and machines, Davenport organized, in 1837, his Electro-Magnetic Association, the first electric stock-company, in America, at least, and probably in the world. Such companies in the United States alone have to-day over a score of billion dollars in bonds and shares and are earning at least two billions a year from service to the public. Surely those "one-hoss shays" could wait outside the humble Brandon smithy while their suspicious owners watched the eager inventor building his motors and tracks that were so soon to show the way in putting horse haulage forever in the "discard!"

After Davenport, came a large group of foreseeing men who struggled bravely and cleverly with the problems of electric railroading; but none of them realized that their trouble lay in not having a cheap supply of electrical energy—"current." They depended on current from "primary" batteries in which acids attacked metals, and that method was, as it is now, very expensive. Burning up zinc in a battery, for example, could never compete in its results with burning up coal under a boiler, whether the steam drives a locomotive or operates an engine in a factory. Unfortunately, none of these early workers saw that Faraday's and Henry's discoveries in magnetic attraction and repulsion, reduced to a machine in Davenport's motor, could, if turned the other way round, so to speak, be the basis for that more wonderful machine, the modern dynamo, now called the "generator," to which the great applications of electricity all look as the source of current energy, no matter how they use it. It is not too much to say that the invention of the dynamo twenty-five years earlier would materially have changed the course of history.

Anyhow, while the steam locomotive, then entering upon its triumphant career, began to traverse continents with its seven-league boots, the feeble electric locomotive was left to a stern chase for fifty years. A baby is

not much more helpless than was the primitive electric-car motor, draining chemical primary batteries of their costly supply of vital energy. In Scotland, in 1838, an engineer named Robert Davidson tried out such an electric locomotive on the Edinburgh-Glasgow Railway. Patents on various modifications of the basic idea were granted in England and the United States, and many pretty little models of the Davenport type were exhibited by wandering lecturers. They rarely took in enough "gate-money" to pay for the hall hired in which to show their scientific freaks and curiosities; but they set young geniuses such as Edison thinking. About 1847-8, a famous American inventor, Moses G. Farmer, who twenty years later did arrive at a clear-cut vision of the dynamo, built an admirable experimental car—using battery power of course—which carried two passengers. Three years after, a brilliant man, Professor C. G. Page, successor to the great Henry at the Smithsonian Institution in Washington, ran a car over the railroad from that city to Bladensburg, Maryland, using the current from no fewer than one hundred cells of primary battery. He actually got up to a speed of nineteen miles an hour, and then the jars of the overworked batteries cracked under the unendurable strain. That was their finish, as well as the end of poor Page's costly attempts to get to Baltimore. It was not until forty years later that Leo Daft brought the successful electric car to the city of the Star Spangled Banner; and sixty years later that such cars shuttled swiftly between there and Washington in regular hourly trips.

It is to be noticed that all these early workers and experiments dealt with railroads—not with street-railways of any kind. Utterly unknown then were such modern necessities as the "trolley," the "L," and the "tube," all of which still lay many years ahead. Perhaps they were not greatly wanted in the unhurried days of old, when land travel, if not afoot, was done on horseback, or behind the horse in a coach; or sometimes by oxen, in towns of good size. Just as Paris, France, was one of the first cities in the world to have a public system for lighting its streets, so that "City of Light" was also the first to enjoy for a short time in the reign of Louis XIV the luxury of an "omnibus," akin to the stage-coach that plied on the ill-paved, robber-haunted highways across country. Pascal, in 1662, or Baudry, in 1827, may be called the "father of the omnibus," and thus

also of the street-car, which is nothing more nor less than a "bus" on rails. Another fruitful idea was embodied in the light railroads of the two Outrams, father and son, built in England for mines, and nicknamed "tramways" after them.

In 1830, the sprawling young city of New York had reached proudly a population of no less than 200,000 lively, active people, pushing "uptown" at the rate of several thousand more, and several "blocks" more, every year. It must have street transportation lines out to its newer suburbs, and hence that year the famous Broadway stages were started from the Bowling Green, competing in winter with big bob-sleighs. But ambitious Manhattan Islanders had no sooner thrilled with the excitement of dashing along by bus at six or eight miles an hour, than, in 1832, it had put at its service the first horse-car line in the world, that of the New York and Harlem Railroad, extending some two miles up Fourth Avenue from near the City Hall to Murray Hill, where now stands the Grand Central Terminal, noble gateway from which steam has been banished. Only electric locomotives are allowed to haul the thousands of trains that pass in and out of it daily.

Thus the omnibus and the "tramway" had been merged in the one vehicle on flanged wheels, which jogged over the uneven rails laid on stone ties—the first passenger street-railway. It was not until nearly twenty years later that New York City had another; and between 1850 and 1855 half-a-dozen American street-railways were built, although not until 1860 did England or Europe get its first street-railway, when an erratic American, George Francis Train, secured a franchise to operate one at Birkenhead. By that time, the United States had nearly forty, and over eighty more were built between 1860 and 1870. When the first census of street-railways was taken in the United States in 1890, no fewer than 769 were in operation. That great jump forward was wholly due to the fact that, as will now be told, electricity had come to its own. Forever were left behind, as badly defeated rivals, the horse and cable, steam or compressed air, in furnishing street-car service. It has been proved beyond all question that no agency but electricity can handle the surging millions of people massed in the great cities of the twentieth century. One hears a good deal about "jitney" gasoline busses as a means of transportation competing with the trolley. Any bright boy would soon figure out how many scores and scores

of thousands of jitneys would be needed in New York to carry those of its six million citizens who must travel daily. From them and people coming into town who travel over the six hundred miles of track are collected every twenty-four hours more than six million fares, giving the right on most lines to journey more than fifteen miles for five cents at a speed of twenty miles an hour. These cars of Greater New York carry yearly twice as many passengers as all the steam railroads of the United States. Try to form an idea of dealing with such a crowd on elephants or in the jinrickshaws of Japan! If it could

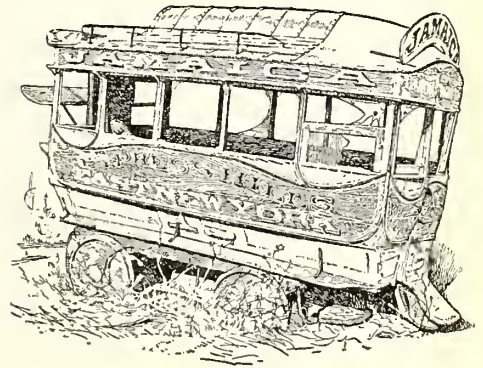

A RELIC OF THE OLD OMNIBUS DAYS

not be done to-day, how could it be done with twelve millions of people fifteen years hence?

One would like to tell here more about the dynamo, because it is the source of all current for its counterpart, the motor, but that is really "another story." No sooner was it discovered that, by spinning the armature coils of wire in front of the electromagnets, a ceaseless, inexhaustible supply of cheap current could be obtained from them, than all the modern electrical arts sprang into being.

About 1875, a poor mechanic, George Green, of Kalamazoo, Michigan, appears to have built one of the old-fashioned pre-dynamo outfits, with overhead wire taking current from a battery; and three years later he went at a bigger car, so that in 1879, at the dawn of the new era, he secured a patent with such broad trolley-claims as to make him seem to be a Moses at the frontier of the Promised Land he did not enter. Then, in 1877, came Stephen D. Field, who, living in hilly San Francisco, had the great idea that electric power could be used instead of the noisy, expensive cable, employed to propel cars on the steep inclines of that city.

Nephew of Cyrus D. Field, the famous,



untiring advocate of the Atlantic telegraph-cable, Stephen was a talented, harum-scarum inventor, as courageous as his uncle. He ordered a dynamo from Europe for his experiments, lost that at sea, then bought another, and soon "found himself busted" on the shores of the Pacific. Nothing daunted, the nervy young engineer came home East, full of the novel scheme, to round up friends and funds; and in 1879 he filed in the U. S. Patent Office what is called a caveat, followed up by a regular application the next year. These disclosed plans for an electric railway, using current from a stationary dynamo, delivered through a third rail or insulated conductor to the car-wheels and traffic-rails, which, divided into sections, formed the return circuit. Just Davenport over again—"and then some."

At this very time, the Siemens firm of Berlin, one of the first great builders of dynamos and motors in Europe, operated at a local exhibition near the river Spree, a little electric car, following up experiments made earlier by Dr. Werner Siemens and abandoned for the same reasons that blocked progress in America. Now, however, the little locomotive, with third-rail supply and track return, pulled briskly for a third of a mile its train of three cars and twenty passengers at a rate of eight miles an hour. It was as much a world sensation as airplane flights are now; and similar ventures were soon afoot as exhibitions in Brussels, Frankfurt, and Dusseldorf. On May 12, 1881, a permanent line, the first of its kind, was put in operation from Berlin to Lichterfelde; but it left out the third rail, the two track-rails being the plus and minus of the little system. And then the rush began in the Old World.

Overlapping the plans of Field and the experiments of Siemens, came the work of Thomas A. Edison, unwearied and fresh from his glorious triumphs with the quadruplex telegraph, the carbon telephone, the phonograph, the incandescent lamp, and a few other such trifles. This mighty hunter before the Lord, with so many hides in his pack, could n't resist the opportunity of further success offered by the electric railway. In the spring of 1880, trying out some ideas of a year before, he built back of his laboratory at Menlo Park, New Jersey, an interesting little road. Edison's first locomotive was, in fact, merely a lighting dynamo used as a motor, laid flat, instead of set upright; and the power from the armature shaft was simply applied to the car-axle by friction

pulleys, afterward changed to pulleys and belts. The two-track rails were the conductors, one set of wheels being insulated. It is noteworthy that the motor had a capacity of not less than twelve horse-power, and that, in describing the primitive road, the New York "Daily Graphic" published a sketch of a 100 horse-power locomotive which Edison even then, with wonted audacity, was planning for the Pennsylvania Railroad, to ply between Perth Amboy and Rahway. In fact, by the time President Frank Thomson of the Pennsylvania came out to risk his life on the ramshackle "road" at Menlo Park, Edison, to use his own language, "was getting out plans to make an electric locomotive of 300 horse-power, with six-foot drivers, with the idea of showing people that they could dispense with their steam locomotives." Henry Villard wanted it for the wheat-fields and the mountain divisions of his new Northern Pacific Railroad.

On one of the demonstration trips, "the train jumped the track on a short curve, throwing off Kruesi, who was driving the engine, with his face down in the dirt. Edison was off in a minute, jumping and laughing and declaring it was a most beautiful accident. Kruesi got up, his face bleeding, and a good deal shaken; and I shall never forget the expression of voice and face when he said, with some foreign accent, "Oh! yes, pairfackly safe!" That was the spirit which carried the new idea to victory! (Kruesi, as you may remember, was the first man to make a phonograph and to hear it talk.) Speaking of some other advances of the kind at that time, Edison remarks, "In the same manner, I had worked out for the Manhattan Elevated Railroad a system of electric trains, and had the control of each car centered at one place—multiple control. This was afterward worked out and made practical by Frank Sprague."

Electric elevated-railway practice was, as a matter of fact, first carried out in June, 1883, under the Field and Edison patents, at the Chicago Railway Exposition, around the outer edge of whose gallery, over a three-foot-gage track, ran "The Judge" locomotive of about fifteen horse-power. This was the first electric railway constructed in America for business purposes; and its surprising success was a great advertisement. It issued regular railway tickets, and in three weeks carried no fewer than 26,805 passengers over an aggregate distance of 446 miles. Rebuilt at the Louisville Exposition the same year,

it repeated its feat on the same scale. Several aspiring young inventors worked on it.

Away off in Belgium, in 1846, was born Charles J. Van Depoele, whose father was master-mechanic in the railway shops of East Flanders. Fascinated by the telegraph batteries lying around the shop benches, young Charles had soon mastered so thoroughly the principles of electricity that

in 1877, active management of the prosperous business; and then, with unconcealed delight, spent in experiments on electric lighting his profits from carving saints. He soon evolved a novel dynamo, and, with its current, lit up a big arc-lamp, whose lurid glare in the overhanging fog from the lake caused a nervous citizen to turn in a fire-alarm. In 1878, Forepaugh's famous circus



From a photograph

THE FIRST ELECTRIC RAILWAY, INSTALLED BY SIEMENS AT THE BERLIN EXHIBITION, 1879

when only fifteen he operated a crude electric light with current from forty Bunsen cells. But his father, impatient with such pottering, said he must have a real trade. Evident artistic ability led to his being apprenticed to a Paris cabinet-maker, who made furniture and carved altars and statuary. This did not hinder the young fellow from taking an electrical course later at Lille, where his family then lived. His enthusiasm even aroused the interest of the teachers, although it sorely disgusted his father. Sturdy young Charles, visiting a relative at Antwerp in 1868, and seeing his hopes blocked at home, slipped quietly away from that North Sea port and sailed for the United States, like many another Old World truant.

He headed for Detroit, which was then making its mark in artistic furniture, just as it has later done in automobiles. Young Van Depoele, who was an artist to his finger-tips, and also knew all about church fixtures, joined hands with a compatriot and founded a factory which at times employed as many as two hundred highly skilled craftsmen. He did so well that he was able to bring his parents to America. He took amusing revenge on his father by turning over to him,

came to town, and Van Depoele lit it up, of course, making an immense sensation; and in 1880 he had one of the very earliest American electric-light companies going at full blast.

A couple of years later, the company began to dabble in electric traction; and in 1883, it built two little roads, one of which, in the autumn of the year, ran for fifty days at the Chicago Inter-State Fair. Thus began Van Depoele's share in a new era of development. He built early roads in all parts of the United States and Canada, and when he died, in 1892, had taken out some 250 United States patents in all branches of electricity. Many improvements have been made in electric railways since those days, but his idea of the little wheel at the end of the trolley-pole—dubbed by the poet Holmes "the witches' broomstick"—still survives, as a running contact under the overhead wire, as the most economical and efficient method of picking up the current from the distant power-house.

Curiously enough, although Van Depoele has been called the "Father of the Trolley," he did not coin the word. It traces back to another pioneer, John C. Henry, a young telegraph-operator, with courage and ideas



of his own, one of which, now universal, was that of suspending the supply conductor-wire over the track by means of span-wire, supported, in turn, by the poles along the line. Henry's first traveling contact for a line out of Kansas City to Independence, some ten miles away, was a little four-wheel carriage, which gripped to and ran along the underside of the overhead supply-wire, feeding current to the car motor. It was virtually a child's toy-carriage turned upside down, and was hauled by a flexible cable, string fashion, connecting to the motor, which thus trolled it along. At first it was called a "troller." Then the street-car men and the passengers changed it to "trolley"; and that it has ever since remained as a general popular name for all electric street-railways.

As will be seen, inventors and their efforts were rapidly multiplying. Soon their name was legion. One or two others still stand out in the historic perspective of the new art, and their efforts must be noted briefly as they began to mark out distinct lines of experiment or success. Thus there was Leo Daft, a clever English photographer, who took the first large views made in America, and gave New York City its first power-circuits for operating electric motors. He picturesquely named his first electric locomotives after "Morse," "Volta," "Ampere," and "Benjamin Franklin." Beginning in 1883, Daft did some very interesting work on several roads, including the New York Elevated Railroad, and one, an Adirondack hill-climber, on Mount McGregor, where General Grant died, and where regular railroad coaches were hauled by electric power for the first time. Early in the spring of 1885, Daft began to equip the Hampden Branch of the Baltimore Union Passenger Railway Company. While this had a third rail with track return, it was probably the first regularly operated electric street-railway in the country.

In the early part of 1885, Professor Sydney Short, a young physicist at Denver University, began some interesting experiments out in the foot-hills of the Rockies. The "series" system was used, in which, as in the early arc-lighting, a constant current went through all the motors in series succession on the line. But after awhile it was found that the "multiple" was the way to do it, with the motors across the current circuit, like incandescent lamps; or, to use a simple comparison, like the rungs in a ladder between the two uprights. But Short, undiscouraged, went on

to great successes in "multiple" trolleys here and in England. He was very successful also with gearless motors, in which all energy-wasting gears between the motor armature and the driven car-axle are left out.

Yet one more method of operation and its crude "try out" must be here brought into the picture. Short had worked with a "conduit" system, or concealed feed-rail, to prevent any fatal human contact with the really deadly high-voltage current he was using. Evidently, this avoided the use of the overhead-wire method, which had many objections. Now, about the same time, watching the successful cable street-railways of the day, with cars, like monster buckets, hooked on to the stout wire rope traveling in the slotted road-bed, two young patent lawyers, E. M. Bentley and W. H. Knight, put into operation a proposed rival. It may be regarded as the prototype of all the "conduit" street-railways now operating successfully on many busy thoroughfares. The two-mile stretch of the Bentley-Knight system on the East Cleveland, Ohio, road gave new meanings to such words as "plow," "slot," "shoe," and "conduit." Operating quite well even through the deep snows of the lake shore in the hard winter of 1884-5, it has its worthy claim to have been also one of the earliest lines to collect a five-cent fare as a commercial electric street-railway.

A famous wit, crossing the choppy English Channel, was very seasick, when a friend besought him, as a Britisher, not to give way, saying, "Brace up! Britannia rules the waves!" "Then why does n't she rule them straight?" was the indignant inquiry. A brisk young lieutenant from Uncle Sam's navy now burst into the electric-railway field with the proposition that the way to operate electric railroads was to rule them straight. Made jury secretary of the famous Electrical Exposition at the Sydenham Crystal Palace, England, in 1882, Frank Julian Sprague had to use the smoky old London "Underground" a good deal, and at once wanted to run it electrically, as it now is. His clever plan was to have rigid rails overhead as well as underneath the car, all in one plane, and current contact with the overhead rails by means of an upward-pressing wheel or cylinder. With that began an inventive career unsurpassed in brilliance and success. Sprague came into the electric railway just at the moment when it needed some great achievement to sum up all that had been done before, to enlist capital, and to shape things for the long future. Re-

turning to America in 1883, Sprague entered the service of Edison, then improving his incandescent-lighting system. But the Dewey of the trolley was too full of his own ideas to be interested in those of any other man or to bother about orders from anybody. He cut loose! Napoleonic in temper and character, his moves and advances were made so swiftly that, almost overnight, the central-station industry found itself with the gift from him of the power-motors so badly needed for its lighting circuits.

Sprague had, as business partner, Edward H. Johnson, who had been in like association with Edison and, encouraged by the dazzling success of their power-motors, the two kindred spirits flung themselves into the trolley industry with no delay and precious little money. Some of Sprague's first work was done on the Manhattan "L"; but mischance would have it that the great financier, Jay Gould, a small man physically, stood near the car controller while the test car was being operated. An exposed safety-fuse "blew" with a startling flash, Mr. Gould tried to jump off at the risk of his life, and "subsequent proceedings" did n't interest him at all. Nothing daunted by ill-luck, Sprague at once took on a street-railway job, and soon had some minor work done neatly.

His great opportunity came at Richmond, Virginia. The contract taken there would have been staggering to any but a sanguine inventor willing to risk his very last dollar in

backing up what he believes in. Completion was called for in ninety days of a street-railway with twelve miles of track, a central power-plant, the overhead line, and forty

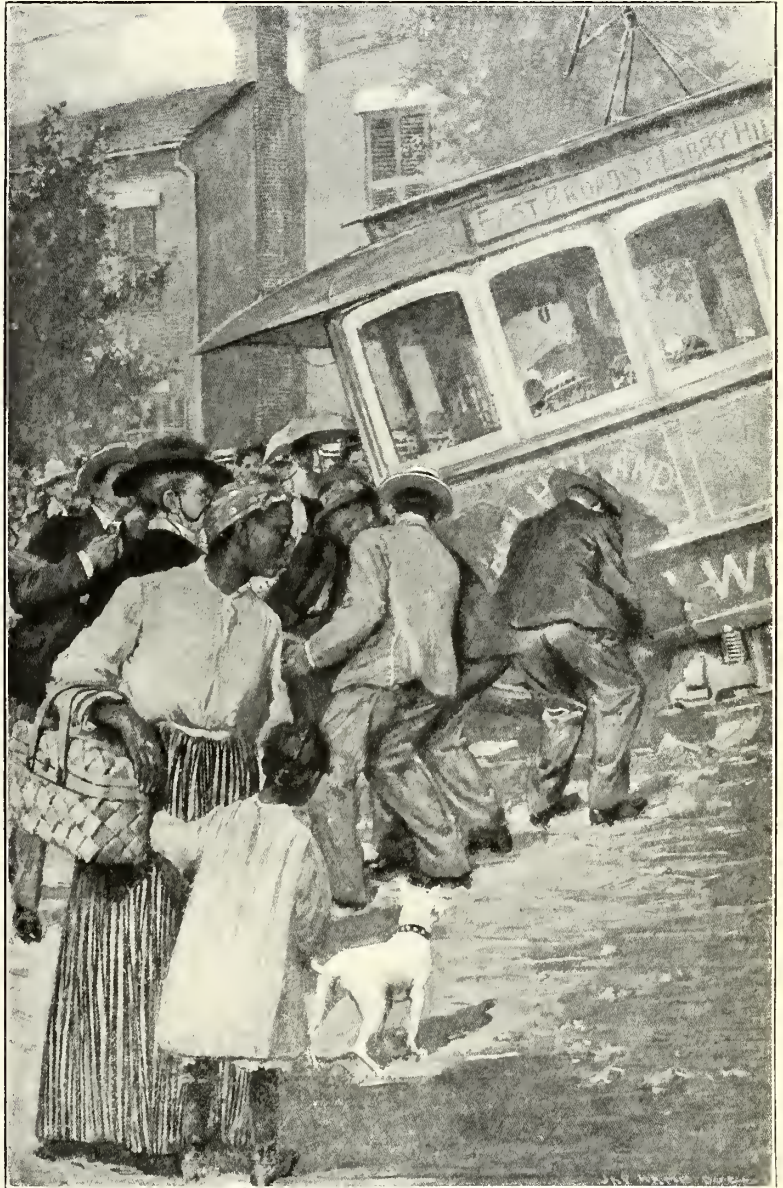

From "The Electric Railway," by Frank J. Sprague, in "The Century Magazine," August, 1905

A DERAILED ELECTRIC CAR—A FREQUENT INCIDENT OF THE EARLY DAYS IN RICHMOND

cars with eighty motors (one on each car-axle), and all the needed controllers and appurtenances. This was nearly as many motors as were then giving uncertain railway service throughout the world. Moreover, grades of eight per cent. were to be



tackled, and no fewer than thirty of the cars were to be in use at one time. The difficulties to be overcome were stupendous, and the young inventor had barely signed the contract when he was stricken with typhoid fever. He had mighty little shot of any kind left in his locker when in February, 1888, the road went into commercial operation. Its success was instantaneous, as was also the effect on the public, on capital, and the whole range of electrical application. Watching those mysterious cars climb up the steep, slippery grades of Richmond, an old colored man ejaculated his fervent blessing; "Fust dey freed de darky, and now dey freed de mule!"

A curious grouping had occurred around the trolley—blacksmith, telegraph-operator, photographer, naval officer, carver of wooden saints, patent lawyer, college professor had been needed in the combination of "all the talents" to which is owing the modern electric railway. Whatever may be the method of latter-day operation, including one or two variations and developments still to be noted, fundamental principles and appliances were now all clearly established, foreseen, or promised. Little or nothing could be added except by way of achievement. It was all in Davenport's feeble beginnings.

At first, electric street-cars ran singly, usually with one motor over the floor or chassis. Then the motor was slung underneath, on the car bottom or the axles. Sprague hit on the universal "wheelbarrow" method of motor suspension in 1885. Pretty

soon, owing to the enormous growth of traffic and increase in weight of the cars, with steel-girder frames, two motors were the approved practice, with the car often hauling the cars, even on the streets, in long trains, a dangerous practice, but the only way to carry the crowds of passengers unless there are elevated roads or subways, freeing the thoroughfare of such traffic. The train method has been a favorite with the numerous "inter-urban" trolley systems supplanting or supplementing ordinary steam railroads across country. The better to operate these trains, ingenious "multiple unit" systems, seen at their best on the "L" or in the subways, have been very successfully worked out by Sprague and by the late George Westinghouse, who applied the experience derived from his air-brake main-line methods.

And this brings us to a point where we may best leave the "story of the trolley" before it lures us into "another story," which is after all the same—that of the clever application of the identical inventions already noted to the operation of regular cross-continent railroads. America has already four per cent. of such lines electrically equipped, and the largest electric locomotives, rated at no less than 4200 horse-power. All the world is following suit, in England, Central Asia, India, Japan, Africa, and Australia, with no need for fuel of any kind, but whose coalless power-plants, driven by water-wheels, drink their ever-renewed energy from the spring, the dewdrop, and the melting glacier.

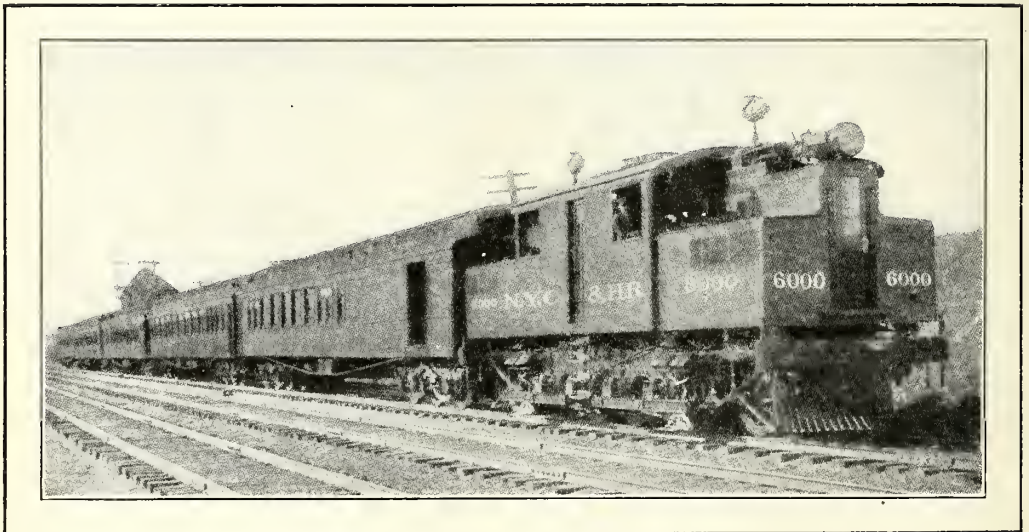

THE FIRST ELECTRIC LOCOMOTIVE, WEIGHING 100 TONS, FOR THE NEW YORK CENTRAL RAILROAD. OPERATED ON TEST TRACKS NEAR SCHENECTADY, N. Y., NOVEMBER 12, 1904

# THE THOROUGHBRED

By A. MAY HOLADAY

At Stanford, the final week of each term signifies a closed season for social events, and is further marked by midnight hours and is further marked by midnight hours with a sudden frenzied devotion to study.

On a morning near the end of a final week of cramming and "ex-es," a notice printed in huge letters on the Encina bulletin-board arrested the attention of all who passed through the lower hall.

SEMINAR TO-NITE  
POLITICAL SCIENCE II  
ROOM 261, C. CRAMER,  
8 P. M. 75¢.

From the bunch of second-year fellows grouped about the notice came deep sighs of mingled relief and satisfaction, as few were prepared for the "poly-sci ex," scheduled for the following morning. Carleton Cramer was a senior and, aside from being a "wiz" in that particular course, he seemed to possess an uncanny sense of the questions that would be asked; for he had compiled lists of questions given in all the poly-sci ex-es for years, and knew them forward and backward.

So it followed as a matter of course that room 261 was more than comfortably filled by eight o'clock that evening. In the hours that followed, Cramer expertly covered an entire term's work—eliminating improbable questions and dwelling upon important points with the zeal of a cub reporter covering his first assignment. Every ear was attentive, while pencils scratched busily at intervals. Seventy-five cents apiece was little enough to pay for all this information—if only they could retain it until to-morrow!

The hum of glee-club practice and the faint tinkle of mandolins drifted in through the open windows, followed by echoes of a "rough house" from down the corridor. And then all was quiet.

Toward midnight, attention began to waver; and it was then that Tubby Wells became keenly alive to an emptiness in the region of his stomach.

"Say—Cramer!" he called out in a hoarse whisper. "Hold off a minute, won't you, while I go down for a pot of coffee? It's my treat. We can't keep this up any longer!"

"I feel that way too," Douglas McNear confessed. "I'm getting a dickens of a headache!"



"Good work, Tub! Bring me a sandwich!"  
"Me too!"

Carleton Cramer straightened his tired shoulders and heaved a sigh of relief. "Recess for fifteen minutes," he announced professionally.

Tubby found Bill Towner in the act of locking up the little basement shop that supplied the Hall students with every want—from a shave to a sandwich. The fat sophomore was a favorite of Bill's and one of his regular customers.

"Just in time, eh, Bill? Gimme a pitcher of coffee and a dozen sandwiches—or pie if you're out o' sandwiches. And hustle, Bill! We're in seminar with only fifteen minutes' recess."

"Not studying!" Bill queried in a tone of mock dismay. "Feel bad anywhere?"

"You'll be the one to feel bad if you don't get a move on." Tubby jammed the sandwiches into his pockets and grabbed the pitcher of warmed-over coffee and the stack of cups.

He was greeted with exaggerated sighs of satisfaction from the seminar bunch, sprawled comfortably over the beds, the chairs, and the window-seat.

"Don't know what we'd do in Encina without Bill's shop on seminar nights," Dexter MacDonald mused as he bit into his sandwich.

"Yes, and every other night, too!" remarked Tubby Wells, gulping his coffee.

"Bill would have to shut up shop if it was n't for Tub," Doug McNear laughed. "Say, fellows, have you seen the latest edition of the 'Dippy'? It lists the chief



characteristics of one John Chester Wells, better known as 'Tubby.' Favorite occupation—resting; favorite expression—"When do we eat?" nickname—Hungry."

"Aw, fellows, lay off!" growled the subject under discussion. "Looks now as if I have plenty of good company."

Cramer thought it time to change the subject. "What do you fellows think of Fred Herron as president of Encina Hall? Careful—I'm on the nominating committee!"

Immediately there was an uproar of excited comment, voiced with the extreme frankness that characterized this group of sophs. From experience they knew that they could say just what was in their minds and trust the bunch to absolute secrecy.

"Herron's a Block-S man, and ever since he entered Stanford has gone in for athletics—"

"He's one of the most ambitious, hard-working seniors in the Hall; has good ideas, too—"

"But—don't you think he fights for his own ideas just because they *are* his ideas?"

"Always impresses me as a chap who is grand-standing for applause," was another blunt comment.

"Oh, I don't know. I never felt that way about Fred," Cramer defended generously. "Personally, I'd like to see him land the honor. He's a keen dresser, a whiz at athletics, and popular with the girls."

"I'll admit that Herron's the type to attract the girls," Dexter MacDonald quietly interrupted, "but what have *they* to do with the selection or election of Encina's president? The question is: What do we Hall fellows want in the chap we make responsible for Hall discipline? I say, we want a good sport who can govern *himself* first of all!"

"Right, old kid! Now you've said a whole train-load!" Bob Scott offered approvingly. "And any chap who banks on the soph support must remember that, before he can hope to dish out discipline to others, he must be enough of a sport to take the first helping himself."

"One of the eating-clubs will put up a man." Tubby was musing aloud from his comfortable station on the foot of the bed. "Then there's Herron—still—" His inflection implied what he had left unsaid. "Fellows, we need new timber! Why not a candidate backed by the sophs? Really, I feel sort of responsible—"

"Say, that's rich!" Cramer chuckled.

"Yes, is n't it!" Tubby was never at a loss

for a reply. "Nobody's done anything yet, eh, Cramer?"

"No. But Fred Herron seems to be going strong wherever I've heard any mention of probable candidates."

"Let's put up a candidate of our own. You know we've done a lot of things together, and when *we* back anything it's always a winner!"

"I've just been thinking," Dex began, rather hesitatingly, "of a chap who is everything we could wish in the way of a good sport. In fact, if he had n't been, he'd never have stuck it out here for three years, handicapped as he's been. He's an excellent listener, and makes *right* decisions—fair to both sides. His judgment is good. There is a possible objection: he is n't what you'd call popular, because he has never tooted his own horn enough; he's too confounded busy making hay while the sun shines from grass that grows under the other fellows' feet."

"Hear! Hear! Who is this paragon of perfection?"

"Lead him out!"

"A-b-s-o-l-u-t-e-l-y! Name him, Dex."

"He's a junior—Jerry Fraser; and fully merits his nickname—'Slats.'"

And then bedlam broke loose in room 261. Even Tubby, the imperturbable, was agitated into an upright position on the bed. Some one thrust a head through the doorway and demanded "less noise, or, by gum!"

"That dry ball!" Scotty exclaimed tragically, with all a boy's contempt for one who chooses to be studious rather than athletic.

"Aw, Dex, have a heart!" cried another. "All the pep he's got you could park on a quinine capsule."

"What's he ever *done* since he came to Stanford?" another questioned dryly.

Dex had anticipated some opposition and was not visibly discouraged. "If you fellows just knew Slats as I knew him in Richmond Hi! You have no idea of what he's been up against for the last three years. It would have floored most of us. When a fellow gets absolutely nothing from home but growls and whines because he is n't there helping to support the family— Well, I'll leave it to you, could he find much time to *do* anything besides earn the money that keeps him going and carry his fifteen hours of school work each term? Give him a chance. We need him. He's a real discovery, I'll say!"

"Of course, we're no end sorry for Slats; we just did n't understand how things were

with him," ventured Cramer, as he saw the chances of his friend, Herron, slipping a bit. "Still, in a case like this, we should n't let ourselves be swayed by sympathy for a chap."

beginning to fidget and the conversation must not be allowed to lag, lest time should be called.

"Why not give a swell party; invite the same girl for Slats and Herron; then let 'em scrap it out and the best man wins?" was the first brilliant suggestion, to be greeted with groans, jeers, and pillows.

"How 's for takin' the two of them up to the very top of the Coast Range and spillin' 'em out up there? The trip home would sure be a test of a good sport." But that suggestion did n't seem to "take."

Dex MacDonald's face wore a troubled look. Not that he objected to any sort of test; he was loyal enough to feel that Slats would come out with flying colors. But his thoughts kept straying back to Richmond, to the boy's poor little home, the uncongenial atmosphere, the discouragements he had met on every side. And here at Stanford, Slats had few intimate friends to throw a friendly arm across his shoulder as they walked along. Nothing ever

seemed to come his way. But as president of Encina, Slats would come in close contact with hundreds of fellows whom he had never known. It would be the making of him!

And then suddenly Dex's groping thoughts collided with a real inspiration. "I have it!" he cried confidently. "Let a soph get up a



"SIX PAIRS OF EYES APPRAISED THE TALL, LANK FIGURE" (SEE PAGE 1159)

"Slats does n't need sympathy!" Dex defended warmly. "All he needs is a fair show. Why, if a real test came, he 'd stack up as all wool and about two yards wide! Try him and see!"

"How?" To Tubby, all this was far more interesting than Poly Sci; but Cramer was



little party and invite Slats and Fred Herron, the two candidates for the test, and some girls—”

“Oh, man! We ’ll go to Sticky Wilson’s and a show afterward,” Merve Kane tossed off grandly.

“‘Sticky’ is the word, all right,” Doug McNear groaned reminiscently, “but why the ‘we?’”

“As a diplomat, Merv, you ’d be worth nothing—and lots of it! Where could you find any test there? As I was saying when you cut in, let them all *think* the party is to be the regulation sort; then the disappointment will be keener. It’s no trick at all for a fellow to be a good sport so long as things keep coming his way; but it’s the *unexpected* that tests his mettle, believe me! We ’d find out some things about the girls, too. Personally, I think it’s time they got something they did n’t expect. The members of ‘the 500’ are entirely too set up. They’re making door-mats of us fellows. With a Stanford co-ed, a party is n’t a party unless it’s just as she has planned it. Walk? A fellow’s a cheap skate if he even hints it! Now I’d suggest that Cramer, here, represent his friend Herron’s interests at the party, and see what kind of a sport he really is. Someway I can’t believe Herron will stand up under the test as Slats will.”

“Who ’ll be the soph to engineer the party?”

“Who has just had a check from home?”

Dex countered skilfully. Then he laughed, with the rest, at the deep silence. “We ’ll divvy expenses. The kind of party I mean won’t cost much, anyway.”

“I say let Dex be the soph.”

“Not on your life! I don’t need to test Slats. Where’s a doubting Thomas?”

“Doug McNear!”

“Just the one! He has the reputation of giving more swell little parties—”

“Here’s your program, Doug,” Dexter put in confidently. “Invite four of the same girls you had last time, as partners for the four boys—Slats and Herron, Cramer and yourself. We ’ll keep mum, and all except Cramer will naturally think this is to be another of your select little parties—until things begin to happen. We ’ll all trust to your sense of fairness, Doug, and if Slats does n’t convince you that he is a thoroughly good sport, no matter what your test, then I’m done!”

“The thing kind of grows on me. I—there’s a girl I want to test, too,” Doug added frankly, while a slow red tinged his

cheeks. Doug did everything well. Always well supplied with money, it was from choice that he lived in the Hall—the center of the democratic life at Stanford—rather than endure the restrictions of frat-house life on the Row. Nevertheless, Doug had many friends along the Row; and with the co-eds he was most popular, for he had never fallen short of their expectations.

Carleton Cramer arose. “Fellows, this promises to be a lark, and I’m glad to be in on it for various reasons, but—you can’t stage the affair until Saturday afternoon, so I say we finish this seminar.”

Doug stacked his coffee-cup on top of the pile. A grin spread over his face. “Nothing but a collision with a comet will keep me from carrying this thing through! Keep mum, all of you! I was just now holding onto an idea when, all of a sudden, I felt it squirm. It’s a warm one, too!” he chuckled as he picked up his syllabus.

But no one dreamed of the hidden traits of character that this lightly planned test would bring to light.

It was not until Friday evening that Jerry—better known as “Slats”—Fraser received his invitation to Douglas McNear’s party, and it left him weak from surprise. Had it come at any other time, he could not have accepted it, but exams were all out of the way; and, while his cash was low, he’d hustle all the morning and later make up for it—somehow.

No one could have understood how much this little party meant to Slats. It was the first social invitation of any kind that he had received for months, and gradually he had given up all hope of “getting in” with any of the congenial little groups whose good times he was never asked to share. How well they knew each other, and what a difference such intimacy must make in the life of a student!

In a school where the masculine element outnumbered the feminine four to one, it is the privilege of the fair co-eds to pick and choose; and at Stanford they, naturally, exercise their advantage to the limit—making dates for months ahead and carelessly breaking them if anything more attractive presents itself.

Knowing this, Slats was not surprised when Doug named the girls who had accepted his invitation on such short notice. No doubt, Doug had made his proposition sound attractive, and, judging by the past, they anticipated something elaborate. The four girls were Clara Kendall, popular and

attractive; Alicia Manning, who formed the exact center of the campus group in which she moved, lightly sipping the pleasures of life; Bess Blair, Alicia's shadow and shock-absorber; Betty Williams, a first-year girl. But in spite of her father's money and her own popularity, Slats felt that Betty was not a snob. He had long realized that a co-ed's favor would prove a too-expensive luxury; therefore he had never dared do more than bow to vivacious, brown-eyed Betty Williams, but that did not prevent his *thinking* about her. And now had come this opportunity of being with her for a whole afternoon!

After a full Saturday morning's work, Slats brushed his stubborn, reddish hair and his well-worn "best" suit with unusual care, and polished his shoes until they shone. As he approached the waiting group on the library steps, a quick glance told him that Betty was not there!

Six pairs of eyes appraised the tall, lank figure in the unmistakable "ready-mades" that contrasted somewhat sharply with their own tailored suits. The three boys, Fred Herron, Carleton Cramer, and Douglas McNear, gave him a cordial greeting. The girls greeted him rather coolly. Of course, this rather seedy-looking individual was their classmate and Doug's guest, still they did n't have to rave over him.

Suds helped to break the ice of the first awkward moments. Suds was a Scotch terrier, mascot of Encina Hall and true friend of every boy in the building. But with the girls, who did not fully appreciate his affectionate nature and the prints of his dusty paws on their shoes and dresses, he was not so popular.

"What is keeping Betty?" Alicia Manning murmured impatiently. Alicia was not accustomed to waiting. Then she turned to Doug. "I suppose you would n't give us a hint about this party even if we guess?"

"You might try," Doug teasingly suggested.

"A theater-party!"

"I'll say an automobile trip somewhere." Bess had visions of a luxurious limousine and the elaborate lunch at Sticky Wilson's later.

"What 's the difference where it is!" remarked Clara, practically. "It 's a joy to be out on a day like this. But where is Betty?"

An idea came suddenly to Alicia. "Why, of course! why did n't we think of it before! Betty is a DZ now, and the house has probably broken this date for her."

Jerry Fraser's hope of seeing Betty that afternoon quickly faded. The DZ's, nicknamed "Dizzies" by the male portion of the campus, demanded implicit obedience to all house rules and regulations. And breaking the dates of first-year members was just one of the little pleasantries indulged in by the older co-eds and sanctioned by the house.

"That settles it," said Doug, regretfully. "Let 's go."

Slats noticed the others pairing off. "Suds and I will be partners and chaperon the party." And he grinned, in spite of his keen disappointment. "Come on, you scallawag!"

Doug and black-eyed Bess Blair started on ahead, Herron and Alicia following, and Carleton Cramer bringing up the rear with Clara. Suds was in his element as he chased his partner in circles around the party.

"Where 's the car, Doug?" asked Herron, with a fixed, expectant smile. He thought he knew where Doug had parked it.

"Car! Who said anything about a car?" their host parried, as he led the way toward the Row.

The others followed politely, but wonderingly. What sort of party *was* this, anyway? But as they reached the end of the Row and turned into the back road that led toward the hills, a flying figure leaped into their midst. "Hello, folks!" she panted. "Did n't expect me, did you? Well, I 'm sick in bed in my room. Remember that, every one of you! And my room-mate is guarding the door," she finished with a giggle.

"Why, Betty!" Alicia's eyebrows raised in disapproval. "What if your sorority sisters discover the trick?"

"Let 'em! I 'm sick of being bossed. I feel just like a bird let out of a cage, so don't spoil it, Alicia."

Slats' drooping spirits had revived visibly. Now he 'd get to walk with Betty. But Cramer evidently had other plans.

"Come on, Betty," the senior urged. "We 're both on that Cosmopolitan Club program committee, you know, so let 's plan it now."

Slats obligingly stepped back with Clara, and found her jolly good company. The road into which they were turning was thick with dust, and the French heels and dainty dresses of the girls were entirely unsuited to a tramp in the hills, which now seemed to be Doug's objective.

Presently Bess remarked sweetly: "I understood this was to be a party, Douglas. Looks more like an endurance test."



"Endurance test! Already? Why, we're hardly off the campus yet."

"This hobo tramping is pleasant—like the toothache. If you had warned us, we might have worn clothes suited to an occasion of this sort."

Doug caught the veiled sneer in her voice. It was n't what she said, but the way in which she said it, that gave him an uncomfortable feeling.

In direct contrast was Betty Williams, who accepted all the little discomforts good-naturedly; and to see her, one would think this trip to have been of her own planning. Racing gaily ahead with Suds, her foot plunged into a hole in the mountain road and she fell, tearing an ugly, jagged rent in the front of her dress.

"First casualty!" she called back as she sprang to her feet and rescued her dusty hat.

"I'm mighty sorry, Betty!" Cramer sympathized, brushing off the dust with his handkerchief. "What a shame to ruin a new silk dress!"

"Oh, you silly! Don't you suppose it can be mended? If it can't, I'll embroider a flower over it. What's the difference, anyway? Don't you just love it up here—the redwoods, the ferns, the wonderful stillness, and everything?"

But to Alicia and Bess, the tramp was proving anything but enjoyable. Bess soon recalled the fact that one ankle always *had* been weak; and Alicia regretted various dates *she* might have made for the afternoon. Together they poured their indignation into the sympathetic ears of Fred Herron, who quietly tried to smooth things over. He could n't understand Doug's attitude at all—showed poor taste—mighty poor! Then, as his own discomfort gradually increased, he began openly to champion the girls' cause.

"Aw, Doug, call a halt and let's send down to Paly for a taxi! We fellows can stand it all right, but the girls are all tuckered out. It's a fine, large time we're having, but I hope you did n't expect us to traipse five miles up these hills just to view the scenery." His tone was sarcastic; his thin veneer of polish was beginning to show signs of cracking.

"Well—partly." Doug's tone pledged nothing. He turned to his companion—the girl who had largely occupied his thoughts during the term just past. She was just as pretty as ever, but somehow—to-day—"Tired, Bess?" he asked.

"Of course! Who would n't be?" Her

black eyes snapped warningly as she stared on down the dusty road.

It was then that Slats happened to glance over at Betty and caught the twinkle in an eye that plainly said, "You're ashamed and so am I." And suddenly the sun grew much brighter, and the world became, to Slats, an altogether different place.

A little later, when the party had stopped to rest beside the road, Slats exclaimed, he stretched himself comfortably on the grass, "Say, this is great!"

"You bet!" Cramer echoed, fanning himself with his sombrero. "We're soft, though ought to do this sort of thing oftener."

"Heaven forbid!" Alicia groaned, with a rueful glance at her shoes. "Get down, you horrid beast!" this to little Suds, who had playfully jumped against her dress.

Bess added in an audible whisper, "And to think I broke a date to motor to San Jose for *this*!"

Herron politely swallowed a yawn as he flicked the dust from his sleeves. There was a bored expression on his handsome face. Aloud, he wondered who or what had suggested this hiking party, anyway.

"I thought it would be a lark to give you all a surprise. Cheer up, we're almost there." Doug threw a searching glance toward Fred Herron. He was seeing things he had never seen before. Herron the president of Encina, with all the diplomacy and tact and understanding that the office demanded! Why, if he could n't even govern himself—Doug set his lips stubbornly. He'd see the thing through!

They stopped before a rustic cabin, almost hidden by the giant redwoods towering above it. Patient hands had transplanted wood ferns about the doorway and walks, and filled the rustic boxes with wild flowers. Smoke curled invitingly from the chimney.

"The summer home of a good friend of my stepfather's," Doug was hastily explaining. "Mrs. Richards is here and will chaperon us. Here at last!" he called out to the motherly little woman, who fairly beamed as Doug introduced his friends.

The rustic chairs proved a grateful haven to the weary hiking party. But as usual, Bess's critical glance began wandering over the big comfortable room, including the owner in its sweep. And as she nudged Alicia and whispered a comment on calico dresses, she did not notice the pained expression on Doug's face.

How hungry they all were! Mrs. Richards was explaining the delayed dinner. she Doug and I thought you 'd all enjoy life novelty of helping to cook it." ab: Lovely!" chimed Betty and Clara in Burus. But Alicia and Bess leaned wearily owl in their big chairs; they were hungry a looking would be a novelty, all right, fat they 'd had quite enough novelty for tfe day. They were going to rest. b: "I 'll get the wood," Slats offered quickly, lout I may have to eat ome of it if you girls pon't hurry with the 'inner."

"Let me peel the spuds," said Cramer. "I 'm a whiz at that."

"I 'll help you," Clara offered.

"Herron and I will extend the table with boxes and boards," Doug promised. "Come on, Fred."

Herron "came on," but without much enthusiasm. He was sure he had a blister on each heel, and his shoes were so confounded dusty; he 'd caught cold or something, too, and felt like the dickens. It was plain to Doug that Fred was not greatly enjoying the affair that had been planned in his honor.

After Slats had filled the big wood-box he found himself engaged in the pleasant task of slicing the ham and his fingers at the same time, while Betty stood by with the big skillet.

"Why, Jerry!" she exclaimed, "You 've torn your coat!" And she proceeded to mend it while the ham sizzled appetizingly, and Jerry's thoughts were a jumble of brown eyes, pink cheeks, and the thoughtfulness of a girl who would bother about a tear in a fellow's coat.

The dinner was an unqualified success. The mashed potatoes were a fluff of white, thanks to Clara, and the ham as delicious as turkey. Mrs. Richards's hot biscuits and honey met with instant approval, and

her blackberry pie was listed as Number One in Class A. Even the disdain of Alicia and Bess was not proof against a dinner like this. There was absolutely no style about it, still—they had to admit that it was good.

When they had all gathered in the front yard, a fine limousine in all its shiny newness came into view along the mountain road. The Hillman-Smiths from Burlingame!

Alicia crimsoned with embarrassment.



"SLICING HAM, WHILE BETTY STOOD BY WITH THE SKILLET"

Her first impulse was to hide. What if they should recognize her—and this frumpy little woman in the calico dress! Then an idea gripped her. She 'd risk it. She waved her hand and ran eagerly down to the road.

Mrs. Hillman-Smith's clear tones carried far in the mountain air. "Alicia! You did n't *walk* up here! Of course! We can take three of you."

There was n't much doubt in any one's mind as to the personnel of the three. And with a few hollow words for Doug and a chilly nod thrown in Mrs. Richards's direction, Alicia, Bess, and Herron hurried



toward the waiting car and were soon lost to view in a dust-cloud.

Doug and Cramer slyly exchanged a solemn, knowing wink, and then burst into shouts of laughter—much to the delight of Suds and the mystification of the rest of the party. But no amount of questioning could make them divulge the secret—which must always remain a secret.

"Slats, don't you think it's about time for us to start?" Doug asked, after a glance at his watch.

"Any time suits me. Of course, we can walk down faster than we came up."

"We're not going to walk," Doug grinned. "Like the Hillman-Smith's, we'll drive down in style. There's a fliv out in the shed."

"Know anything about a fliv?" Cramer demanded.

"Nothing but a few funny stories. But just trust your Uncle Doug!"

While the two girls were thanking Mrs. Richards for a delightful afternoon, Slats threw one long arm affectionately around Doug's shoulders, and with the other drew Cramer into the circle.

"I wish I could tell you fellows," he began, "what this day has meant to me. It was

mighty fine of you, Doug, to include me, and I'll never forget it—never!"

"It has meant more to *me* than to any one else," Doug muttered ambiguously as he slipped away for a final word with Mrs. Richards.

"Mother," he whispered to this "good friend" of his stepfather, "you've been wonderful to come up here in that frumpy dress to help me carry out my plans. She—she—did n't make the grade. Neither did Herron. He's what the fellows call a 'foul ball.'"

"Never mind, son; it has been worth while to find out which of your friends have a veneer of polish and which are genuine all through."

Doug brightened. "Slats is a brick! So are Betty and Clara. Look for me home next week-end, Mum. By!"

The future Encina president, all unconscious of the test to which he had been subjected, was assisting a brown-eyed girl into the back seat of the fliv. Cramer, noting her satisfied little smile, shot a meaning glance over at Doug.

"Clara and I will sit in front with you," he said briskly, and added, as he climbed aboard, "Now, old timer, let'er go!"



LOOKING THROUGH THE ARCHES OF THE "QUAD," LELAND STANFORD UNIVERSITY

# THE BIGGEST TOP IN THE WORLD

By HARVEY W. ROOT

THE biggest and most wonderful spinning-top in the world has just been finished. It is no toy, however, for it is too large for even the greatest giant in an old-time fairy tale to amuse himself with. The huge thing weighs one hundred tons—as much as two car-loads of coal—and is thirteen feet through, which is more than the height of two tall men.

Of course no string or rope could be used to set such a top in motion. Attached to the shaft, which runs through the center of the great mass of metal, is an electric motor of three hundred and fifty horsepower, or approximately the power required to run the elevators in a New York City hotel. When the current is turned into this motor it begins to move the top; and even though it is such a powerful driving force, it takes almost two hours to set the top going at full speed. So nicely is the top balanced, and so great a momentum does it gather, that if left to run down alone, after the power is turned off, it would take eighteen hours to come to a stop.

The engineers in charge of the top do not dare to let it revolve too fast, for fear the mass of metal will fly apart, but hold it down to a speed of eight hundred revolutions a minute. This is a speed which the engineers call slow, but it does not seem so to any one else, for at that rate if a fly could hold himself on to the rim of the big wheel, he would travel more than six miles a minute.

The big top can not be set up and spun anywhere. It has to have a carefully made

case in which to run. This case looks like a huge turnip, and is made of metal. The air is pumped from the inside of this case, forming a vacuum similar to the inside of an electric-light bulb. This is done to reduce friction to the lowest point and allow the top to run as easily as possible. The case is

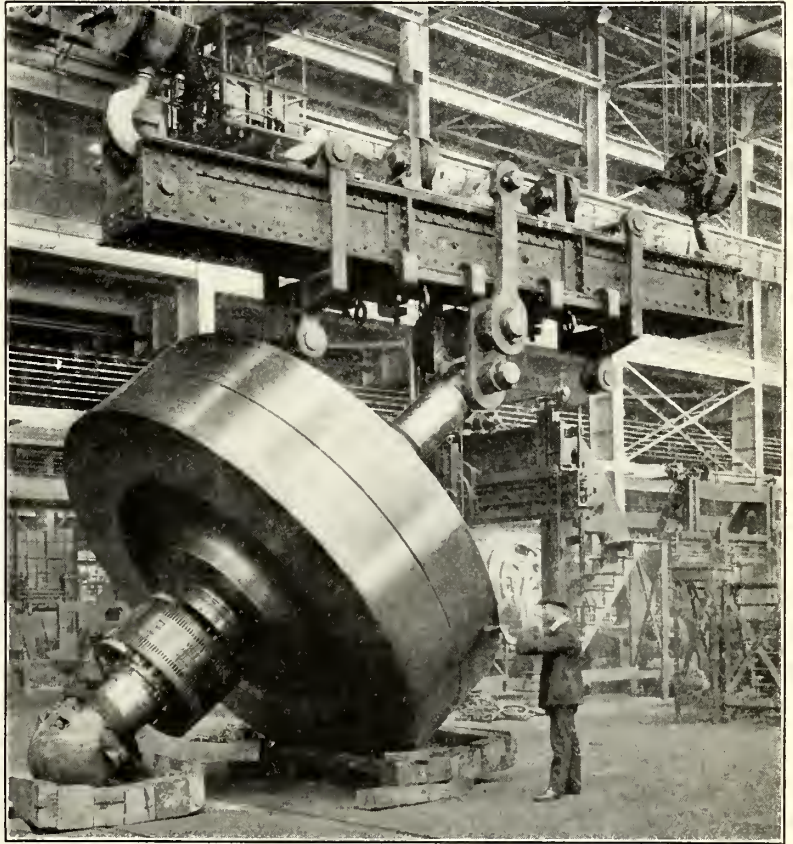

THE COMPLETED TOP, AS IT LAY IN THE SHOP WHERE IT WAS MADE

arranged so that while the top is running, case and all can be inclined at an angle, either forward or backward.

This provision for tilting the top while it is spinning is to enable it to do its work; for this huge affair, which took ten months to build and cost thousands of dollars, was not made as an interesting exhibit, but for serious every-day work—the prevention of seasickness.

Ever since men began to go to sea in ships, many have suffered from seasickness,



caused by the rolling motion of the boat. Many people can not travel even a short distance on a boat without being sick, and numbers of people dare not cross the ocean for fear of this trouble. All kinds of experiments have been tried, and millions of dollars have been spent, trying to find a way to prevent ships from rolling, but with little success until Mr. Elmer A. Sperry, scientist and inventor, discovered that it could be done with a big top spinning rapidly.

His invention, known as a "Sperry stabilizer," has been tried out on some freight-carrying vessels and on some pleasure boats. It has proved to be so successful that now this biggest top ever made, shown in the accompanying pictures, is to be installed in a passenger ship, the *Hawkeye State*. When she starts for Europe on one of her trips this summer she will have the big stabilizer fastened to her frame down in the hold, where, like a great giant standing astride the boat and pressing first with one foot and then with the other, it will prevent rolling; and then no one is likely to be seasick.

Strange to say, when the top stands perpendicular it has no effect on the ship, no matter how fast it is spinning; but let it be tilted at an angle, and it presses three hundred

tons on one side and lifts an equal amount on the other. It is this application of six hundred tons of energy which stops the rolling, just at the beginning, and this energy is controlled by a little mechanism which Mr. Sperry calls the giant's "brains." This is a small wheel known as a "gyroscope," which is kept revolving very rapidly and responds to the slightest roll of the vessel. By means of an electrical connection the brains set the big case to tilting, either forward or backward as may be required, as soon as the boat is three per cent. off level—which is too slight an angle for a person to notice. Just as soon as the top begins to tip, the forces in the spinning mass of metal exert their tremendous power on the vessel and prevent it from rolling. As the top swings first one way and then the other, it stops the effect of each wave on the ship, and therefore it never gets to rolling; for Mr. Sperry found that it is the combined effect of many waves that rolls a boat.

And, therefore, with this invention, in addition to the wonders of sailing under the water and through the air, the summer of 1922 will see people sailing to Europe on a vessel whose deck will always be level, no matter how rough the sea or weather.

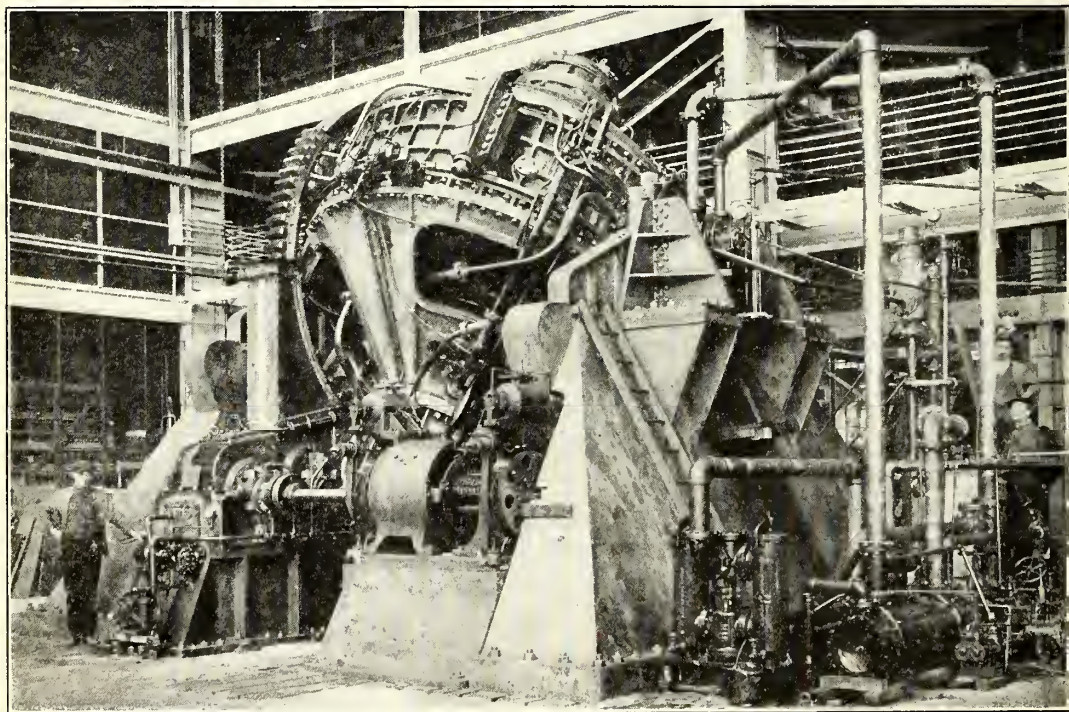

THE CASE WHICH CONTAINS THE BIG TOP, TILTED AT AN ANGLE

# THE MYSTERY AT NUMBER SIX

By AUGUSTA HUIELL SEAMAN

Author of "The Boarded-up House," "The Sapphire Signet," "The Dragon's Secret," etc.

## SYNOPSIS OF PREVIOUS INSTALMENTS

A CURIOUS chance had led the two cousins, Bernice and Sydney Conant, upon the mystery centering around the girl, Delight, at the old, deserted phosphate mine-pool, Number Six, in the wilderness of southern Florida. Delight seemed to be in the care of the Everglades guide, "Jerry Sawgrass" and his ignorant, but good-natured, "cracker" wife, who lived in the old farm-house at one side of the pool. Yet she clearly was no relative of theirs and she knew nothing about herself save that heretofore she had always lived with them in the Everglades. She confides to the cousins that she has in her possession some charred old papers that Jerry had once tried to burn; and from what she has overheard, she suspects there is something about herself that she does not know. She has learned to read what is written in these papers, but they tell her little. Finally, she confides them to her new friends, extracting a promise that they will show them to no one or reveal what she has told them. On reading the papers, the cousins find them to be the fragments of a journal relating mainly to scientific matters and the fauna and flora of the Glades. There are only two or three references to "the child Delight," and these only make the mystery greater.

Bernice and Sydney think that a lawyer from New York, a Mr. Tredwell, who is staying at their hotel, may know something about the affair, as they have discovered that Jerry seems much afraid of him and anxious to keep out of his way. Sydney proposes quietly to cultivate his acquaintance and find out what he knows. Then, next afternoon, when the cousins visit Number Six again to return the papers to Delight, they come upon a curious state of affairs!

## CHAPTER VII

### THE WHITE FLAG

WHEN at last they got around to the farm-house, Bernice was completely out of breath, but she managed to pant: "This is *very* risky, Syd!—Delight would not—like—it. They'll see us—sure as anything! What's the—matter, anyway? Are they—all away?"

"Just come along and see for yourself!" he retorted, and led her boldly up to the front veranda. Hesitatingly, she mounted the rickety steps.

"I suppose they're all away somewhere. But Syd, even if they *are*, we have n't any right to go into the house, have we? And, besides, they may come back any minute."

"Come along and don't fuss!" he ordered. "You'll see for yourself when we get inside."

Still doubting, she crept in after him and looked about. The first glance revealed nothing very different from what it had been on their earlier visit. There was the decrepit rocker by the empty fireplace; the rough table and two other chairs stood in their usual positions. But a closer scrutiny revealed the subtle difference. Though this furniture was still in evidence, there was not a single sign of any more personal belongings in sight. Various small articles they had noticed when they were there before were missing. A glance into the two little bedrooms disclosed the rude old beds bare of every vestige of mattress or covering. The

kitchen beyond possessed no trace of cooking or eating utensils. Then at last the truth dawned on Bernice.

"Sydney!" she gasped, "they've—*they've gone!*"

"Gone—cleared out—beat it!" he averred. "Must have done it in a dickens of a hurry—sometime between yesterday afternoon and this. Probably sometime last night. It would be most likely."

"But why—*why* should they have done it so suddenly—and Delight never said a word about it to us—yesterday?"

"Of course she did n't say a word—because the poor kid never knew a thing about it! I'd be willing to swear to that! Probably they were planning it and wanted to get her out of the way while they got ready, so sent her off on that long errand. Must have been some shock to her when she learned the news!"

"But I can't understand why they did it, —they've only just come here. Why move away so soon again?"

"Plain as the nose on your face! Jerry's afraid of that Mr. Tredwell—wants to get out of his vicinity—thinks, no doubt, that the gentleman will try to hunt him up. Naturally, he does n't feel safe here now."

"What *do* you suppose Jerry is afraid of him for?" cried Bernice.

"If we knew *that*, we'd probably know the explanation to a lot of this mystery," answered Sydney, sagely.



"Then why not try to find out from Mr. Tredwell? Why not ask him right out if he knows anything about it?" demanded Bernice.

"You forget—your promise to Delight!"

Bernice clapped her hand to her mouth. "Oh, I *did* forget for a minute! Why—why—but this is *maddening*, Sydney? How in the world are we ever going to solve the mystery when—when we're so hampered by a promise like that?"

"Perhaps it is n't intended we *should* solve it. Perhaps it's none of our affairs."

"But what about poor little Delight?" moaned Bernice. "For her sake, we surely ought not to give it up! *She* wanted to solve the mystery about herself. Think how she learned to read and all that, in order to do it. I'm just certain she must be heart-broken over this change." She glanced about the room again. "Perhaps they really have n't gone for good. See!—they have n't taken the furniture with them!"

"I've a very strong suspicion that this furniture went with the house and did n't belong to them, anyway. They would n't be likely to cart heavy things like this around with them in their wanderings. And if they were going in such a hurry, they could n't arrange to take it, of course. So *that* does n't mean anything."

Bernice continued to roam disconsolately about the forsaken rooms, hoping against hope to discover some clue to the mystery of this new development.

"Would n't you think Delight would have tried to get word to us in some way—to let us know she was going and where?"

"She undoubtedly had n't a ghost of a chance. Probably it was all sprung upon her when she got back here yesterday afternoon—maybe not till well toward night. What chance would she have to get word to us? I can just see them, scurrying around and packing up and loading their traps in the little mule-wagon (the mule's gone too, of course—I looked in the shed outside) and hustling off in the darkness. You can warrant your last dollar that they left at night and got well away from here before morning so they would n't be seen on the roads in this vicinity!"

"Sydney, where do you suppose they went? Would it be possible to trace them—to follow them?"

"There's only one place they're aiming at—the Everglades, of course!" declared Sydney. "That's the only spot where

Jerry is safe—where he's pretty sure he can't be followed or found. But it will take them some time to get there, traveling in that mule-wagon,—if they *are* going to travel that way,—and, of course, there are a dozen different routes they might follow. Yes, I presume they could be traced—until they get into the Glades. But who's going to trace 'em—and why? I confess that I have neither time nor opportunity nor sufficient cause to show for doing it."

They went out and sat on the rickety veranda, many of whose boards were half rotted away or completely missing. Out beyond the straggling orange-trees, the pool lay like a sheet of turquoise under the afternoon sky, but the charm of the spot had largely fled, as far as Bernice was concerned, now that the chief actor in the scene was gone. Suddenly she sat up very straight, inspired with a new idea.

"Sydney, I'm simply certain that Delight never went away from here without trying to leave some sort of a message for us! Can't you see how likely it would be? Not only because she was growing quite fond of us, but because we still have the package of papers that belong to her. Surely she would want them back sometime. She would try to let us know where she was going and—how to get them to her, perhaps!"

"Yes, it *is* likely," agreed Sydney, after thinking it over judiciously. "But just how she could manage it is rather a puzzle. She simply could n't send a message to us at Jasper—that's out of the question."

"She could write us a letter—she knows how to write. Why not?"

"She knows how to write—yes. But think of the difficulty of trying to get a letter to us. In the first place, she undoubtedly had no envelopes or stamps. These she'd certainly have to get somewhere, and it's altogether probable she had no money. Then how would she get it in a post-office without being discovered? No, I feel pretty certain it would never even occur to her to do it that way. But she *might* have written a note and left it around here somewhere, quietly, after the others were out of the way, hoping we'd find it when we came."

"Oh, *fine!*" cried Bernice, happy once more to have some thread, no matter how slight, to hold to. "I'm simply certain that is what she's done. Now let's get right to work and hunt this place over—thoroughly—and I know we'll come across it!"

They began systematically, each taking a

separate room, and went over every nook and cranny, hoping to come upon the looked-for missive. But the search was fruitless. Then Sydney suggested that they change off and each search the rooms the other had gone

here, the more I think of it, the more certain I feel that she *has* left a message *somewhere!* We know it 's not in the house—let 's just try to think where would be the most likely place she 'd put the thing. Come to think of it, the house would



"'BUT SHE MIGHT HAVE WRITTEN A NOTE'"

over, in case some hiding-place had escaped notice. This they did, with no more satisfactory result. The old house was empty of any clue that would lead to their further enlightenment. Again they went out on the veranda in despair and sat dangling their legs over the unrailed edge.

"It 's strange," said Sydney, after a long silence, "but in spite of not finding anything

palms in the florist shops up North, the kind that was always used as a decoration at weddings and parties. When she rode along the wild Florida roads lined with them, she said it was as if they 'd just been decorated for some festive affair.

This clump was larger than usual, the great leaves falling over in such a way that they formed a tentlike appearance.

n't be a good place, after all, for she 'd always have run the chance of having it discovered before they left. Of course, Jerry could n't read, and I rather doubt if the cracker woman could, either; but they 'd be sure to scent something queer about it."

They both sat with their heads in their hands for quite a while, thinking with deep concentration of the problem they faced. It was Bernice who had the first idea.

"Syd!" she exclaimed radiantly, "what geese we are not to have thought of it before! Delight expected to meet us down by the big palmetto clump across the pool. Of course, that 's where she 's left the message!"

Sydney merely gave a grunt, expressive of thorough disgust at his own density, and shouting, "Come on—quick!" set off at a run for the point indicated. In due time they reached the great, spreading, scrub-palmetto clump. Bernice always said that these clumps reminded her of the expensive



"Look out how you search in here," warned Sydney. "These clumps are a great retreat for rattlesnakes, especially in this warm spring weather."

They accordingly reconnoitered the ground with the greatest care before venturing to make their way far into the growth. But finding no unwelcome occupants anywhere about, they boldly penetrated to its very depths. Nowhere did there seem to be the slightest sign of a communication, but a sudden whoop from Sydney, around at the farther side, brought Bernice to him at a run.

"Look at that!" He pointed to a little twig, not more than five or six inches high, sticking out of the ground a few feet away from the edge of the clump. It would never have been noticeable except that a bit of white cloth had been tied to the top in such a way as to wave out bravely on the breeze, like a miniature flag or signal.

"Is n't it the queerest thing!" cried Bernice. "I sat here and gazed at that thing for fifteen minutes, while you were away, and while I thought it a little peculiar, it never dawned on me for a minute what it was really intended for. Of course, she meant to attract our attention to it in that way. Was n't it clever of her! But, come!—let's dig down under it and see what's there!"

This time their search had its reward. Down in the fine white sand, only a few inches under the surface, they came upon the message Delight had left for them. It was a note written on a small and not very clean scrap of paper—a piece of a paper bag, in fact. The writing appeared to have been done with a bit of sharpened and charred wood. Doubtless she had possessed neither pen and ink nor pencil. And while the spelling was correct, the letters were stiff and peculiar, showing a great lack of practice. It began with marked lack of ceremony.

"They are going away from here—for good. I do not know why, but I must go with them. Bernice, I love you. You have been my friend. You are both my friends. Keep the papers for me. They are safe with you, and I know you will not tell my secret. Perhaps sometime we will see each other again. If there is any way I can ever get a message to you, I will, but I do not hope for so much, for I know where we go—to the Everglades again. He says it is the only place we can live—and be safe. I do not know why this has come so suddenly. He did not intend to go back. Something strange must have happened.

"There is no time to write any more. I hope you will find this. Bernice, if you will dig down further you will find something I leave for you.

It is all I have to give. I wish you to have it. I was so happy with you. My heart is breaking, but I can do nothing but go. Good-by to you both. I will never, never forget you.

"DELIGHT."

They looked at each other without speaking when Bernice had finished reading it aloud. There was something deeply touching about the little message. It brought a lump into their throats. Bernice turned to dig down further in the hole where the note had been, and presently brought to light a long string of the light-blue glass beads that the Seminole Indian women are so fond of wearing. She laid it in her lap and looked at it for a long moment. Then she put her head down on her knees and sobbed quietly, while Sydney walked away a bit and whistled a loud tune to prevent himself from indulging in any unmanly show of emotion.

"There's no use, Syd," declared Bernice, getting up and wiping her eyes, after an interval, "we just can't let that dear little thing go like this. You can't begin to think what a—a hold she's taken on me. Why, I feel almost as if it were a sister of mine that was being dragged away and hidden for some unknown reason. I've made up my mind to one thing—I'll keep my promise to her, of course, literally, but I'm going to spend every moment from now on in solving this matter somehow or other. I'm simply sure it can be done!"

"Needless to say, I'm with you," agreed her cousin. "And what's more, I've a very distinct notion how it's going to be done!"

"Oh, have you, Syd?" cried Bernice, smiling up at him with eyes to which tears had again started. "That's great of you! What is your idea? I'm crazy to know."

"The first step is to pump Mr. Tredwell as skilfully as possible about what he knows of Jerry Sawgrass and then—"

"But, Syd," objected Bernice, "you don't even know Mr. Tredwell yet. How are you going to get acquainted with him, to begin with?"

"Don't bother your head about that detail, Miss Conant," replied her cousin, loftily. "The matter is already adjusted. Yours truly made that gentleman's acquaintance last evening in a long chat we had on the hotel veranda—after you had retired to your downy couch!"

"Sydney Conant!—and you never even told me! How did you do it and what did he say?"

"I was keeping it as a surprise. I got some information out of him that is going to be rather valuable, I expect. But I can't tell you now—it 's growing late and we 've got to be making tracks for home and I must do a little tinkering with that self-starter before we do. It was n't working right this afternoon."

Bernice slipped the beads into her handbag and trailed after him acquiescently enough, as they made their way to the car, but her mind was a seething caldron of questions and determinations and longing to meet again with Delight.

## CHAPTER VIII

### THE FORCE OF A PROMISE

ON the way home, Sydney gave Bernice an account of his interview with Mr. Tredwell the previous evening.

"He was sitting on the veranda, smoking, when I came out, after bringing you folks home from our bungalow. I did n't think of speaking to him—singularly enough, *he* opened the conversation with *me* by asking if I happened to have a match about me. I always carry a box around in my pocket, so I obliged him, and gradually we got to talking. It ended in my sitting down by him and remaining there till nearly midnight.

"He 's a very interesting man, has traveled all over, especially in Florida, and knows the State like a book. And, by the way, we found out that he had known your mother's father very well, had gone to the same college with him. Though he graduated two or three years later than your grandfather, he was quite a friend of his. They rather lost sight of each other in later years, for he went to Europe for a long stay. But he was very much interested and wanted to meet you and your mother. Queer—how small the world is, is n't it!"

"That 'll make it all the easier to get really acquainted with him, won't it?" interrupted Bernice.

"No trouble at all about *that!*" declared Sydney. "I 'll introduce him all around tonight. But that is n't all we talked about. By and by we got to discussing this town and the people in it and the queer specimens you see coming in from the wild outside districts. He began it by speaking particularly about a curious 'cracker' fellow who 'd tackled him that day for a job in the mines—said he was a 'good hand tuh make otheh

fellahs work and would like to be a fo'man'! Mr. Tredwell had a hard time assuring the chap that *he* did n't have anything to do with hiring the mine workers. Then he went on to speak of other queer characters he 'd come across, and suddenly, to my amazement, he asked me if I 'd ever noticed that half-Indian chap who came to town once in a while.

"I wondered just how much I ought to tell him,—how much I *could* tell him without breaking that promise to the kid,—but concluded it would n't do any harm to admit at least to *seeing* Jerry. So I said yes, I had seen him once or twice. He went on to say that he had reason to be more than usually interested in that particular person; in fact, would like very much to meet him and have a talk with him. Then he told me the incident of Saturday when he saw Jerry in line at the movie show and tried to get across to him and found him gone when he managed to reach the other side of the street.

"I asked him if he 'd ever met Jerry before and—what do you think he said? 'Yes, once, down in *Fort Lauderdale!*' See how that dovetails in with what little Delight told us? Remember her saying that Jerry left there once in a hurry and went deep into the Glades for a long time afterward? I spoke, quite casually, about Jerry being a rather famous guide and trapper in the Glades, and he said yes, so he 'd heard, but that there was something else that was singular about him besides that. And then—*then,*" here Sydney paused dramatically, "he up and asked me if I knew that Jerry had in his care a *girl* who, it was thought, did not belong to him!"

"I was really put to it how to answer him. If I admitted that I knew, it might involve Delight, and yet I could n't very well say I did n't. So I compromised by simply remarking, 'Is *that* so!' He went on to say that he had heard so when he was down at Fort Lauderdale, some years before, but when he met Jerry and had questioned him about it, Jerry had denied it flatly and then disappeared for good. But he said he had been asking some questions about the town here concerning the guide and found that it was rumored that he *did* have the child with him, though no one had seen her, and that he was also supposed to be married to a cracker woman. He said that he had n't discovered yet just where the man lived but when he did, he was going to try to have another interview with him.



"I did n't say a word about *my* knowing where Jerry lived, but just let him ramble on and tell me all he would. He went on to say that there were very serious legal reasons why he should talk to the fellow, that he had been trying to find him for years without success, and that it was utterly unexpected, coming across him in this region. He had certainly never dreamed of finding him anywhere but around the Everglades.

"Of course, I was absolutely handicapped by that promise to Delight, and could not tell him a thing I knew, partly because I have n't figured out yet whether his business with Jerry will bring more trouble to her or not, and partly because it did n't seem fair to the whole outfit at Number Six—or rather that were once at Number Six! I can not feel that there is anything really wrong about them, or anything like that, and I want to know more about what Mr. Tredwell is driving at before I give him so much as a hint—if I ever do! I did n't get any more out of him after that, for it was growing so late that we both decided to go to bed. But you can see now that we're in for some new developments, perhaps, through him. I'll stay to supper with you folks to-night at the hotel, and get a chance to introduce you all afterward."

In the pleasant twilight after supper, on the hotel veranda, they found Mr. Tredwell, sitting in a corner by himself, smoking the inevitable cigar, and apparently just enjoying the fading afterglow, glimpsed through the huge live-oak trees so heavily draped with Spanish moss. Sydney, walking by with Bernice and her mother, stopped to introduce them. Mr. Tredwell rose with alacrity, and, after the introduction, found them chairs. They discovered him to be a quite delightful and entertaining person, full of enthralling incidents of his many travels, which he could recount very realistically. Mrs. Conant and he spent some time in exchanging reminiscences of her father, and so, in a very short time, they all felt quite as if they had known one another all their lives.

It was not till the interview was nearly over that Mr. Tredwell electrified the two young folks by turning to Sydney and casually remarking: "Remember that half-Indian chap we were speaking of the other night? I found out quite by chance to-day that he is supposed to be living out somewhere near one of the old mine-pools known as Number Six, some twelve or fourteen miles from here. No one could give me just

the exact location—at least, not so that I could find it without some difficulty. I believe you have to leave the main road at a certain point and take some obscure trail through the woods. Now, I'm *very* anxious to get at him as soon as possible, for I can't stay in this region much longer. I have urgent business elsewhere. And more than that, my car is laid up with a broken connecting-rod and won't be ready for use short of two or three days. I was wondering whether you would, as a great favor, be willing to drive me out there to-morrow afternoon in your car, if you were n't otherwise engaged. It's a great deal to ask, I know, but I understood you to say that you knew the region around here pretty thoroughly, and I must confess I'd rather take the expedition with you than to go in a taxi. I don't want to start up any talk about the matter."

Sydney and Bernice glanced at each other with one startled look. Could anything be more singular than this particular request? Had it come a few days earlier, they would have been hard put to it to know what to reply. As it was, Sydney saw no reason why he should not cheerfully comply. The expedition promised rather interesting and unusual features, indeed!

"I'll be delighted to," he replied. "Won't we, Bernice? I've been out that way fishing, once in a while. I think I know how to get there without difficulty. We'll all go. Aunt Elsie, would n't you like to take the drive too? You have n't been out that way. We can stay in the car or ramble around and explore the pool while Mr. Tredwell has his interview."

But Mrs. Conant thanked them and refused, declaring she had made an engagement to go to Tampa with her sister-in-law next day. Nothing, however, could have persuaded Bernice to give up her chance to be one of this curious expedition, and so it was arranged that the three should meet at the hotel next afternoon at two o'clock.

When they were alone, just before Sydney left, he whispered to Bernice: "Is n't this the greatest piece of business you ever heard of—our taking him out to Number Six! Lucky thing the kid is n't there now! Say, he'll get some shock when he finds they've 'flew the coop' again, won't he? But don't you dare to show, by so much as the faintest sign, that you've ever been there before or have the least inkling about the thing. You will have to do a nice little bit of acting, I fancy!"

"Of course I won't show that I know anything about it!" declared Bernice, indignantly. "I would n't for Delight's sake, anyway. Gracious! I can hardly wait for the time to come!"

It was with a strange presentiment of impending complications that they set out on the following afternoon. Bernice alternated between wishing madly that Delight

pool and try their luck while Mr. Tredwell went round to the other side to find Jerry. He pointed out the old house in the orange-grove, saying he understood that must be where Jerry lived.

They watched Mr. Tredwell make his way around the edge of the pool, Sydney all the while apparently absorbed in adjusting his bait and making a cast. And they watched



"HE SUDDENLY CONFRONTED SYDNEY AND LOOKED STRAIGHT INTO HIS EYES"

had never extracted that promise from them, and in being thankful that they were not permitted to tell what they knew. But what she chiefly dreaded was being put in the position of having to answer embarrassing questions that could not be evaded. As, however, there was not the slightest use in borrowing trouble, she wisely decided to see how things turned out and not to worry beforehand.

The conversation during the ride was on general subjects, and when at last they reached the pool, Bernice inwardly thanked fortune that they had not once touched on the ticklish topic. Sydney halted at the spot where he usually parked the car, got out his fishing-rod, and announced that he and Bernice would stay on that side of the

him approach the tumble-down veranda, reconnoiter about a bit, and finally ascend to knock on the still half-open door.

"I feel as if I were standing over a mine that was just about to explode!" Bernice confided to her cousin.

"It makes me feel rather mean," added Sydney, "to think I know all the while what he's going to strike, and yet what in the world can I do? We're just bound hand and foot by that promise Delight extracted from us. Sometimes I think it is n't right,—as if it might be better for her in the end if we did not keep it. I don't know—it's a puzzle!"

They could see Mr. Tredwell standing patiently by the door, waiting for an answer to his knock. Then they saw him knock



again and, after an interval, a third time. At last they saw him push the door open, look about and walk in. And after that, nothing happened for a long time, so it seemed. They held their breath, almost, for the "coming explosion," as Bernice insisted on calling it!

Then they saw him emerge from the house and hurry around the pool in their direction—and they knew the struggle was on!

"It 's singular—*very* singular!" panted Mr. Tredwell, when he at last came around to where they were standing.

"What 's singular?" demanded Sydney, as nonchalantly as though he were not perfectly well aware of the facts all the time.

"That house—it 's absolutely *empty*! Are you sure this is the right place?"

"I think I can be *quite* sure of it," replied Sydney, cautiously. "It 's the only farmhouse around here for miles. And one day, not so long ago, I was out fishing at this pool and happened to notice that the house seemed occupied. Are you sure that it is empty—or are they temporarily away?"

"It 's uninhabited—no doubt of it. Some furniture is there, but not the slightest sign of any one really *living* in the place."

"Very queer that he should move away

so suddenly!" commented Sydney, more for the sake of saying something than for any better reason.

"No, it *is* n't strange!" exploded Mr. Tredwell, at last, in thorough exasperation. "It 's only about what I expected, as a matter of fact. Jerry has eluded me before, and I quite expected he 'd try to again. Only I thought that this time I 'd been too quick for him. Did n't think he 'd imagine it necessary to slip away so soon, as he was so well hidden here. He 's a slick article—the slickest thing I ever came across! He has given me the slip every time."

Sydney said nothing, except to murmur his regrets at Mr. Tredwell's disappointment. Later, he ventured to ask if that gentleman intended to try to trace the fleeing guide.

But Mr. Tredwell, deep in thought, paid no attention to this query. Instead, he suddenly confronted Sydney and looked straight into his eyes.

"Tell me," he commanded, in a tone that was not to be gainsaid, "did you ever happen, while fishing here, to have noticed a young girl, about this young lady's age," pointing to Bernice, "anywhere about that house or—or around this pool?"

So, at last, was Sydney brought to bay!

(To be continued)

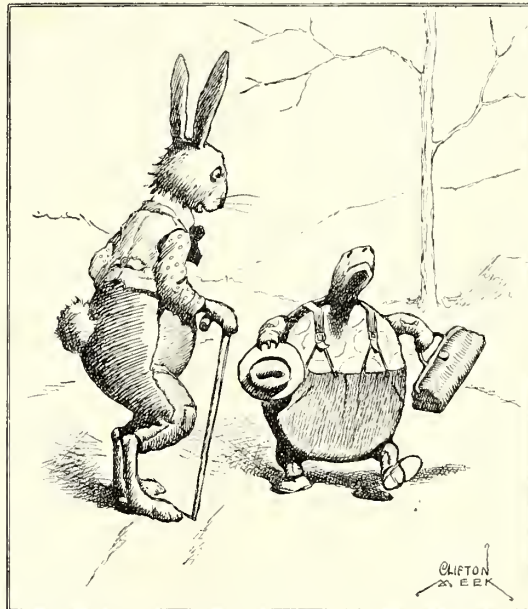

"I SHOULD THINK YOU WOULD GET A CAR, DOCTOR—YOU COULD GET TO YOUR PATIENTS SO MUCH QUICKER."

"YES, CARS ARE SPEEDY, BUT SOMETIMES THEY TURN TURTLE."



ONE OF THE DRAMATIC MOMENTS IN THE PLAY

## GIVING A "SHOW"

By CHARLES K. TAYLOR

WHEN you hear a teacher say, "We like to let a boy or a girl 'develop some project' in which he or she is interested," that, perhaps, sounds dull enough to some of you youngsters. The funny thing is that it is not dull at all. It is really very good fun, only boys and girls discovered it years ago—long before the teachers; since it really means doing something interesting and doing it all yourself.

"Huh!" I hear you exclaim in disgust, "why, we 're *always* doing things ourselves! Don't we make our own wireless sets, and our own cabins, and lots of other things?"

The fact is that you do, only some teachers have just discovered that it is valuable!

Now we can come down to our story. It all took place in a certain New Jersey academy, where, if a boy wants to do anything not on the schedule, he does it himself!

So some boys wanted to give a "show." For a wonder, this school never had given one. There was no stage. There was, however, a large "gym." So they got to work. A boy of fifteen wrote the show—songs and all. And it was n't half bad, either. It may be published one of these days, for it is the kind of show a boy would like to play in! It has a Scotch guard, it has Indians and a couple of massacres; and finally, of course,

the hero marries the beautiful Indian princess, who, by the way, was quite young, so the old chief said—only forty!

No, it was not a serious show. It was mock-serious, perfectly preposterous, in fact, though not an actor gave even a glimmer of a smile—not even when the lone pale-face survivor of the first massacre held up his hand and stopped the dumfounded braves with the remark, "You can't touch me—I have my fingers crossed!"

Well, I did n't intend to write the whole show down for you. I merely wanted to impress you with the fact that a fifteen-year-old boy wrote what he called the "libretto," and that that was very clever.

Then a boy of sixteen wrote the music—all of it. There were quite a few songs, and an "overture." Yes, and the music was very catchy, too, and may be published along with the rest of the show, some day. And when the time came, it was played by a regular orchestra, I'd have you know, violins, horns, bass-fiddle, and all. Now if you ask why the fellows in the show did n't do their own playing of the music, I can only say that all the school musicians were actors and could n't be orchestra at the same time.

Two more boys designed the stage and the





PAINTING THE PROSCENIUM ARCH

proscenium arch. Some high-brows talk of the modernist movement in stage design. These boys did n't know anything about the

modernist movement, or any other movement. But they did design an entirely original stage and arch of a beautiful and effective kind, as the photograph shows. These boys were fifteen and sixteen years old. The trees were flat brown. The lower background behind them was pale green. The background behind the upper branches was pale blue. The curtain was sky-blue.

Now, all the scenes were at night. And the only lighting was from a fire in the middle of the stage. So they made the background solid black,—with stove-pipe paint,—and when the auditorium lights were out, the figures stood out against that background like figures against a dark sky—figures lighted, as I said, only by the flickering fire-light. And the fire, I might add, was on eight inches of wet ashes, and these on sheet-iron; and buckets of water waited behind the wings for accidents that did not happen.

Stage carpenters, from twelve to sixteen years old, constructed a very strong stage and a highly scientific arch, using a semi-bowstring-span idea—a kind of wooden arch. In fact, the photograph gives a better idea of the construction than I can. You can see, too, that the stage slants a little upward toward the back.

A success? Rather! They had to give it twice! And as for the financing—well, folks who wanted to see the show had to buy tickets!

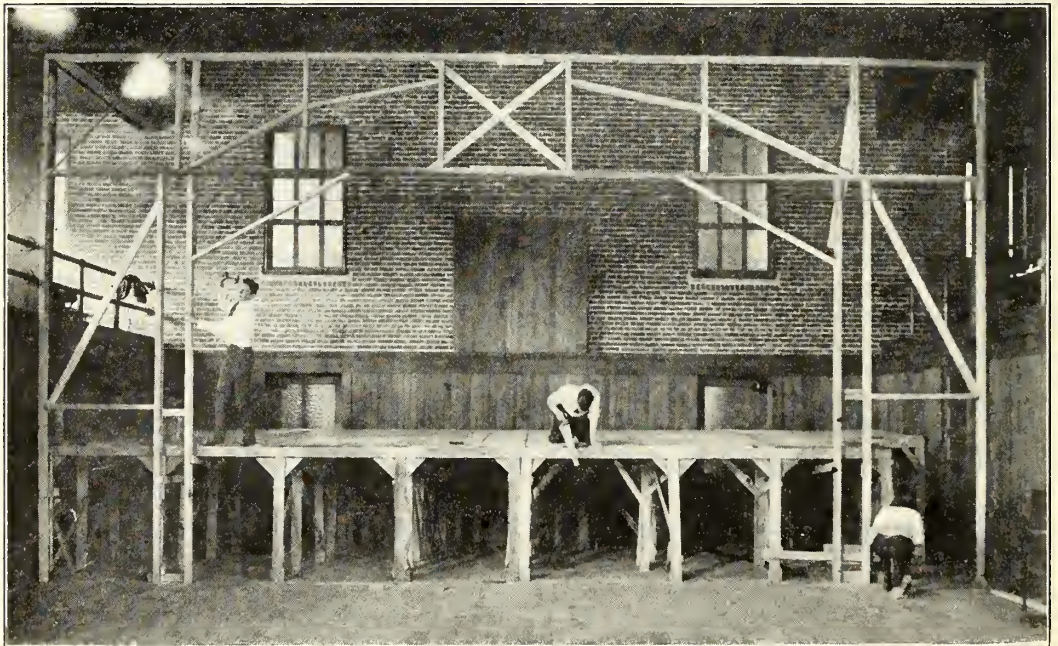

THE STAGE AND ARCH, SHOWING CONSTRUCTION

# THE TURNER TWINS

By RALPH HENRY BARBOUR

*Author of "The Crimson Sweater," "The Mystery of the Sea-Lark," etc.*

## SYNOPSIS OF PREVIOUS INSTALMENTS

WHEN the Turner Twins, Ned and Laurie, alike as two peas in a pod, enter Hillman's School in the autumn they decide that it is their duty to go in for sports. Ned, although without previous experience, joins the football candidates, leaving baseball for Laurie. Ned manages to conceal his ignorance, by earnest labor makes good as a second-team back, and secures a reputation as a clever goal-kicker. In the game before the final contest he is taken to the first team as a substitute and, sent on to kick a goal after a touchdown, succeeds very well. Predictions that he will be called on in the Farview game, however, give him stage-fright, and the morning of the contest finds him in ragged shape after a bad night. He goes for a walk after breakfast into the country, and, far from town and very tired, lies down and goes to sleep. When he awakes it is twenty minutes after the hour set for the game. Panic-stricken, he hastens back to the field, where the game has gone to the fourth period and where the score-board announces: Hillman's 7—Farview 9. Ned, watching from the crowd, sees his team advance the ball to within kicking distance of the enemy's goal, and a substitute, to all appearances himself, summoned from the bench. Amazed, he asks a man beside him who the player is. "Turner," is the answer. "Guess he 's going to kick a goal for 'em."

## CHAPTER XXI

### THE UNDERSTUDY

"BLOCK that kick! Block that kick! Block that kick!" chanted Farview, imploringly, from across the trampled field.

Yet above the hoarse entreaty came Hop Kendrick's confident voice: "All right, Hillman's! Make it go! Here 's where we win it! Kick formation! Turner back!" And then: "25—78—26—194! 12—31—9—"

But it was Hop himself who dashed straight forward and squirmed ahead over one white line before the whistle blew.

"Fourth down!" called the referee. "About four and a half!"

"Come on!" cried Hop. "Make it go this time! Hard, fellows, hard! We 've got 'em going!" He threw an arm over the shoulder of the new substitute. Those near by saw the latter shake his head, saw Hop draw back and stare as if aghast at the insubordination. Farview protested to the referee against the delay, and the latter called warningly. Hop nodded, and raised his voice again:

"Kick formation! Turner back!"

Then he walked back to where the substitute stood and dropped to his knees.

"Place-kick!" grunted a man at Ned's elbow. "Can't miss it from there if the line holds!"

Ned, in a perfect agony of suspense, waited. Hop was calling his signals. There was a pause. Then: "16—32—7—"

Back came the ball on a long pass from

Kewpie. It was high, but Hop got it, pulled it down, pointed it. Ned saw the kicker step forward. Then he closed his eyes.

There was a wild outburst from all around him, and he opened them again. The ball was not in sight, but a frantic little man in a gray sweater was waving his arms like a semaphore behind the farther goal. Along the space between stand and side-line a quartette of youths leaped crazily, flourishing great blue megaphones or throwing them in air. Above the stand, blue banners waved and caps tossed about. On the score-board at the far end of the field the legend read: "Hillman's 10—Visitors 9."

A moment later, a boy with a wide grin on his tired face and nerves that were still jangling made his way along Summit Street in the direction of the school. Behind him the cheers and shouts still broke forth at intervals, for there yet remained some three minutes of playing time. Once, in the sudden stillness between cheers, he heard plainly the hollow thump of a punted ball. More shouts then, indeterminate, dying away suddenly. The boy walked quickly, for he had a reason for wanting to gain the security of his room before the crowd flowed back from the field. At last, at the school gate, he paused and looked back and listened. From the distant scene of battle came a faint surge of sound that rose and fell and rose again and went on unceasingly as long as he could hear.

Back in Number 16, Ned threw his cap aside and dropped into the nearest chair.



There was much that he understood, yet much more that was still a mystery to him. One thing, however, he dared hope, and that was that the disgrace of having failed his fellows had passed him miraculously by! As to the rest, he pondered and speculated vainly. He felt horribly limp and weary while he waited for Laurie to come. After a while he heard cheering, and arose and went to the window. There could no longer be any doubt as to the final outcome of the game. Between the sidewalk throngs, dancing from side to side of the street with linked arms, came Hillman's, triumphant!

And here and there, borne on the shoulders of joyous comrades, bobbed a captured player. There were more than a dozen of them, some taking the proceeding philosophically, others squirming and fighting for freedom. Now and then one succeeded in getting free, but recapture was invariably his fate. At least, this was true with a single exception, while Ned watched. The exception was a boy with red-brown hair, who, having managed to slip from his enthusiastic friends, dashed through the throng on the sidewalk, leaped a fence, cut across a corner, and presently sped through the gate on Washington Street, pursuit defeated. A minute later, flushed and breathless, he flung open the door of Number 16.

At sight of Ned, Laurie's expression of joyous satisfaction faded. He halted inside the door and closed it slowly behind him. At last, "Hello," he said, listlessly.

"Hello," answered Ned. Then there was a long silence. Outside, in front of the gymnasium, they were cheering the victorious team, player by player. At last, "We won, did n't we?" asked Ned.

Laurie nodded as if the thing were a matter of total indifference. He still wore football togs, and he frowningly viewed a great hole in one blue stocking as he seated himself on his bed.

"Well," he said, finally, "what happened to you?"

Ned told him—at first haltingly, and then with more assurance as he saw the look of relief creep into Laurie's face. As he ended his story, Laurie's countenance expressed only a great and joyous amusement.

"Neddie," he chuckled, "you'll be the death of me yet! You came pretty near to it to-day, too, partner!" He sobered as his thoughts went back to a moment some fifteen minutes before, and he shook his

head. "Partner, this thing of understudying a football hero is mighty wearing. I'm through for all time. After this, Ned, you'll have to provide your own substitute! I'm done!"

"How—why—how did you happen to think of it?" asked Ned, rather humbly. "Were n't you—scared?"

"Scared? Have a heart! I was frightened to death every minute I sat on the bench. And then, when Mulford yelled at me, I—well, I simply passed away altogether! I'm at least ten years older than I was this morning, Neddie, and I'll bet I've got gray hairs all over my poor old head. You see, Murray as much as said that it was all day with you if you did n't show up. Kewpie was a bit down-hearted about it, too. I waited around until half past one or after, thinking every moment that you'd turn up—hoping you would, anyhow; although, to be right honest, Neddie, I had a sort of hunch, after the way you'd acted and talked, that maybe you'd gone off on purpose. Anyhow, about one o'clock I got to thinking, and the more I thought, the more I got into the notion that something had to be done if the honor of the Turners was to be—be upheld. And the only thing I could think of was putting on your togs and bluffing it through. Kewpie owned up that he'd been talking rot last night—that he did n't really think you'd be called on to-day. And I decided to take a chance. Of course, if I'd known what was going to happen, I guess I would n't have had the courage; but I did n't know. I thought all I'd have to do was sit on the bench and watch.

"So I went over to the gym and got your togs on and streaked out to the field. I guess I looked as much like you as you do, for none of the fellows knew I was n't you. I was careful not to talk much. Mr. Mulford gave me thunder, and so did Murray, and Joe Stevenson looked pretty black. I just said I was sorry, and there was n't much time to explain, anyway, because the game was starting about the time I got there. Once, in the third period, when Slavín was hurt, Mulford looked along the bench and stopped when he got to me, and I thought my time had come. But I guess he wanted to punish me for being late. Anyway, Boessel got the job. When the blow did fall, Neddie, I was sick clean through. My tummy sort of folded up and my spine was about as stiff as—as a drink of water! I wanted to run, or crawl under the bench, or something.

'You 've pleased yourself so far to-day, Turner,' said Mulford, 'now suppose you do something for the school. Kendrick will call for a kick. You see that it gets over, or I 'll have something to say to you later.'

"Nice thing to say to a chap who 'd never kicked a football in his life except around the street! But, gee, Neddie, what could I do? I 'd started the thing, and I had to see it through. Of course, I thought that maybe I 'd ought to fess up that I was n't me—or, rather, you,—and let some one else kick. But I knew there was n't any one else they could depend on, and I decided that if some one had to miss the goal, it might as well be me—or you. Besides, there was the honor of the Turners! So I sneaked out, with my heart in my boots,—your boots, I mean,—and Hop called for a line play, and then another one, and I thought maybe I was going to get off without making a fool of myself. But no such luck. 'Take all the time you want, Nid,' said Hop. 'We 'll hold 'em for you. Drop it over, for the love of mud! We 've got to have this game!' 'Drop it?' said I. 'Not on your life, Hop! Make it a place-kick or I 'll never have a chance!' 'What do you mean?' he asked. 'I mean I can't drop-kick to-day.' I guess something in my voice or the way I said it put him on, for he looked at me pretty sharp. Still, maybe he did n't guess the truth, either, for he let me have my way and let me kick.

"After that—" Laurie half closed his eyes and shook his head slowly,—“after that I don't really know what did happen. I have a sort of a hazy recollection of Hop shouting some signals that did n't mean a thing in my young life, and kneeling on the ground a couple of yards ahead of me. I did n't dare look at the goal, though I knew it was ahead of me and about twenty yards away. Then there was a brown streak, and things began to move, and I moved with them. I suppose I swung my foot,—probably my right one, though it may have been my left,—and then I closed my eyes tight and waited for some one to kill me. Next thing I knew, I was being killed—or I thought I was, for a second. It turned out, though, that the fellows were n't really killing me; they were just beating me black and blue to show they were pleased.

"Of course, it was all the biggest piece of luck that ever happened, Ned. Hop aimed the ball just right, and somehow or other I managed to kick it. Maybe any one would have done just as well, because I guess it

was an easy goal. Anyway, the honor of the Turners was safe!"

"You 're a regular brick," said Ned, a bit huskily. "What—what happened afterward? I did n't stay."

"Afterward, Hop looked at me kind of queer and said, 'I guess that 'll do for you, Turner,' and I beat it away from there as fast as I knew how, and Mulford sent in some other poor unfortunate. There were only half a dozen plays after that, and we kicked whenever we got the ball."

"Do you think any one but Hop found out?" asked Ned, anxiously.

"Not a one. And I 'm not sure, mind you, that Hop did. You see, he did n't *say* anything. Only he did call me 'Nid' at first, and then 'Turner' the next time. I have n't seen him since. I guess I never will know, unless I ask him. One thing 's sure, though, Ned, and that is that Hop won't talk."

"You don't think I 'd ought to fess up?" asked Ned.

"I do not," replied Laurie, stoutly. "What 's the good? It was n't your fault if you went to sleep out in the country. If any one 's to blame, it 's me. I ought n't to have hoaxed them. No, sir; if Mulford or any one says anything, just you tell them you fell asleep and could n't help getting there late. But I don't believe any one will ask questions now. They 're all too pleased and excited. But, gee, Neddie! I certainly am glad I made that goal instead of missing it. I 'd be a pretty mean-feeling pup tonight if I had n't!"

"It was wonderful!" mused Ned; "you putting it over, I mean. With all that crowd looking on, and Farview shouting—"

"Shouting? I did n't hear them. I did n't know whether there was *any* one around just then! I had troubles of my own, partner! Know something? Well, I think there 's the chap who kicked that goal." Laurie raised his right foot and displayed one of Ned's scuffed football shoes. "I guess I just sort of left things to him and he did the business. Good old Mister Shoe!"

Ned jumped to his feet and pulled Laurie from the bed. "For the love of lemons," he cried, "get those togs off before any one comes in!"

"Gee, that 's so!" Laurie worked feverishly, while Ned turned the key in the lock.

"A fine pair of idiots we are!" exclaimed Ned, as he ripped Laurie's shirt off for him. "Suppose Hop or Kewpie had come in while we were sitting here!"



Hillman's spent the rest of the evening in celebration. In the dining-hall the appearance of any member of the squad was the signal for hand-clapping and cheers, and when Ned entered, followed by Laurie, the applause was deafening. Ned showed himself to be a very modest and retiring hero, for he fairly scuttled to his seat, and kept his head bent over his plate long after the applause had died away. Then, stealing an unhappy glance at Laurie, he found that youth grinning broadly, and was the recipient of a most meaningful wink. After supper, in the corridor, the twins ran squarely into Hop Kendrick. Ned tried to pull aside, but Laurie stood his ground. Hop was plainly a very happy youth that night, although even when happiest he never entirely lost his look of earnest gravity.

"Well, we did it, Nid!" he said joyfully, clapping that youth on the shoulder. "That was a corking kick of yours, son!"

Ned stammered something utterly unintelligible, but Laurie came to the rescue. "Ned says it was the way you pointed the ball that won that goal, Hop."

Hop shot a quick glance at the speaker, and Ned declared afterward that there was a smile behind it. But all he said was: "Oh, well, pointing is n't everything, Nod. *Some one's* got to kick it!"

When he had gone on, Ned and Laurie viewed each other questioningly. "Think he knows?" asked Ned. Laurie shook his head frowningly. "You've got me, partner!" he answered.

And, because neither ever asked Hop Kendrick outright, neither ever did know!

There were songs and speeches and a general jollification after supper, ending in a parade of cheering, singing youths who marched through the town from end to end and at last drew up outside Doctor Hillman's porch and shouted until that gentleman appeared and responded. The Doctor's words were few, but they hit the spot, and when there had been another long cheer for him, and another long cheer for the team, and a final mighty cheer for the school, the happy boys called it a day and sought the dormitories.

Ned was just dropping off to sleep that night when Laurie's voice reached him through the darkness.

"Ned!" called Laurie.

"Huh?"

"Are you awake?"

"Uh-huh."

"Listen. It's a fortunate thing to be a twin."

There was a long moment of silence. Then Ned's voice came sleepily:

"'Cause if one twin can't, the other twin kin!"

## CHAPTER XXII

### THE BOYS MAKE A PRESENT

THE week or so succeeding the Farview game seemed like an anticlimax. The bottom had sort of dropped out of things and there was no immediate excitement to look forward to. The weather became as miserable as weather possibly could, the slight snowfall that followed the rain of Thanksgiving Day lasting only long enough to be seen by the early risers. Perhaps it was well that lack of events and inclement weather ruled, for Ned and a good many other boys in school were no worse for an opportunity to apply themselves, undisturbed, to their studies. Basket-ball candidates were called the first Monday in December, and the twins held a serious conference on the question of reporting. Ned, who felt rather flat since there was no more football, was half inclined to go in for the game, and would have done so had Laurie insisted. But Laurie voted that for the present the Turners had done sufficient in the athletic line, that the honor of the family demanded no further sacrifices on the altar of duty. So Ned abandoned the idea and talked of trying for the crew in the spring.

When December was a week old, the fellows set their gaze on the Christmas recess, which this year began on Wednesday, three days before Christmas, and lasted until the second of January. Eleven days are not sufficient to make advisable a trip across the continent and back, although the twins figured that, with the best of fortune, they would be able to reach Santa Lucia in time for dinner Christmas night. On the other hand, the missing of one connection would delay their arrival until the following afternoon, and, as Laurie pointed out, they were fairly certain to be held up somewhere on the way, and a sleeping-car was n't exactly an ideal place in which to spend the holiday! Besides, there was a noticeable lack of encouragement from home. It had been accepted beforehand that the boys were to remain at the school during the recess, and nothing in Mr. Turner's fortnightly letters hinted that he had changed his mind.

"I 'd just as lief stay here, anyway," declared Ned. "We can have a lot more fun. Maybe there 'll be a bunch of snow, and I 'm dying to try skeeing."

"You bet! And skating, too! And then there 's that other scheme. Must n't forget that, Neddie."

"You mean—"

cost and what we 'll need and everything. I say, we can get Bob to help us, too!"

"Rather! And three or four other fellows, I guess. Every one likes the Widow, and George says there will be five or six fellows here during recess. He was here last year, and he says he had a dandy time."

"Let 's get George this afternoon and get



"AT THE SIGHT OF NED, LAURIE'S EXPRESSION OF JOYOUS SATISFACTION FADED"

"Yes. Did n't you say we 'd do it during vacation?"

"Sure! It—it 'll take quite a lot of money, though, Laurie. And we 'll have presents to buy for Dad and Aunt Emmie and the cousins—"

"The cousins get Christmas cards, and that 's all they do get," interrupted Laurie, decisively. "That 's all they ever give us, and I 'd rather spend my money on something that 'll really—really benefit some one. I guess Dad 'll send us some more money, too, for Christmas—of course he will. We can do it, all right. I 've got nearly seven dollars right now. I 've spent hardly any money this month."

"All right. Some day soon we 'll go downtown and find out how much it 's going to

the thing started. We can find out the—the area and ask the man how much we 'll need."

"Sure! And we can buy it and store it at Bob's. Then all we 'll have to do will be carry it over the fence. Look here, Neddie. Why not do it before Christmas and make it a sort of Christmas present? Say we worked hard all day Thursday and Friday—"

"Great! Only if it snowed—"

Laurie's face fell. "Gee, that 's so! I suppose we could n't do it if it snowed—or rained—or if it was frightfully cold."

"They say it does n't get real cold here until after New Year's," said Ned, reassuringly. "But, of course, it might snow or rain. Well, we 'll do it in time for Christmas if we can. If we can't, we 'll do it for New Year's. I 'll bet she 'll be tickled to death. I say,



though! We never found out about the color!"

"I did," answered Laurie, modestly. "I asked Polly. She said white."

"White! Geewhillikins, Laurie, that makes it harder, does n't it? We 'd have to put on two coats!"

"Think so?" Laurie frowned. "I guess we would. That would take twice as long, eh? Look here; maybe—maybe I can get Polly to change her mind!"

"That 's likely, you chump!" Ned scowled thoughtfully. Finally he said: "I tell you what. Suppose we went around there sometime, and talked with Mrs. Deane, and told her how nice we think blue looks and how sort of—of distinctive! Gee, it would n't be any trick at all to make it blue; but white—" He shook his head despondently.

"Cheer up!" said Laurie. "I 've got the dope, partner! Listen. We 'll tell them that it ought to be blue because blue 's the school color and all that. Mrs. Deane thinks a heap of Hillman's, and she 'll fall for it as sure as shooting. So 'll Polly! Come on! Let 's find George and get the thing started!"

"Better get Bob to go in with us, too. He said something about wanting to pay his share of it, so we 'd better let him in right from the start. After all, we don't want to hog it, Laurie!"

A fortnight later the exodus came. Of the fourscore lads who lived at Hillman's, all but eight took their departure that Wednesday morning, and Ned and Laurie and George watched the last group drive off for the station with feelings of genuine satisfaction. Life at school during the eleven days of recess promised to be busy and enjoyable, and they were eager to see the decks cleared, so to speak, and to start the new way of living. Ned and Laurie had had plenty of invitations for Christmas week. Both Kewpie and Lee Murdock had earnestly desired their society at their respective homes, and there had been other less insistent, but possibly quite as cordial, invitations. But neither one had weakened. George half promised one of the boys to visit him for a few days after Christmas, but later he canceled his acceptance.

Besides George and the twins, there remained at school five other fellows who, because they lived at a distance and railway fares were high, or for other reasons, found it expedient to accept Doctor Hillman's hospitality. None of the five, two juniors, one lower middler, and two upper middle-

were known to the twins more than casually when recess began; but eating together three times a day and being thrown in each other's society at other times soon made the acquaintance much closer.

Meals were served at a corner table in West Hall, and during recess there were seldom fewer than three of the faculty present. That may sound depressing, but in vacation time an instructor becomes quite a human, jovial person, and the scant dozen around the table enjoyed themselves hugely. In the evening Doctor Hillman held open house, and Miss Tabitha showed a genius for providing methods of entertainment. Sometimes they popped corn in the fireplace in the cozy living-room, sometimes they roasted apples. Once it was chestnuts that jumped on the hearth. Then, too, Miss Tabitha was a past mistress in the art of making fudge, and on two occasions Mr. Barrett, the mathematics instructor, displayed such a sweet tooth that the boys lost the last of their awe and "ragged" him without mercy. Several times the doctor read aloud, choosing, to the boys' surprise, a corking detective novel that had them squirming on the edges of their chairs. Toward the last of the vacation, Laurie confided to Ned and George that he wished recess was just beginning.

To Ned's and Laurie's great disappointment, neither snow nor ice appeared, and the weather remained merely briskly cold, with sometimes a day like Indian summer. But I am getting ahead of my story, which really comes to an end on Christmas Day.

More than a week before the closing of school, the four conspirators had finished their preparations for the task that was to provide the Widow Deane with a novel Christmas present. In Bob's cellar were many cans containing blue paint, white paint, linseed oil, and turpentine. There were brushes there, too, and a scraper, and a roll of cotton rags provided by Polly. For in the end, it had become necessary to acquaint Polly with the project. Against Bob's back fence reposed all the ladders, of varying lengths, that the neighborhood afforded. Wednesday evening Ned and Laurie and George herded the other boys into George's room and explained the scheme and asked for volunteers. They got five most enthusiastic ones.

Nine o'clock the next morning was set as the time for beginning the work, and at that hour, nine rather disreputably attired youths

appeared in Mrs. Deane's yard, arriving by way of the back fence, and began their assault. The first the Widow knew of what was happening was when, being then occupied with the task of tidying up the sleep-

was what at first glimpse looked like a convention of tramps. They were armed with ladders and brushes and pots of paint, and they were already very busy. Across two trestles set on the grass-plot, the stolen shutters were laid as fast as they were taken down. One boy, flourishing a broad-bladed implement, scraped the rough surfaces. A second plied a big round brush, dusting diligently. Numbers three and four, as soon as the first two operatives retired, attacked with brushes dripping with white paint. In almost no time at all, the first shutter was off the trestles and leaning, fresh and spotless, against the fence. Every instant another shutter appeared. Mrs. Deane gazed in fascinated amazement. One after another she recognized the miscreants: the two Turner boys, George Watson, Mr. Starling's son, Hal Goring, the Stanton boy, and the rest; but, although recognition brought reassurance, bewilderment remained, and she hurried downstairs as fast as ever she could go.

Polly was on the back porch, a very disturbed and somewhat indignant Towser in her arms, evidently a party to the undertaking, and to her Mrs. Deane breathlessly appealed.

"Polly! What are they doing?" she gasped.

"You 'll have to ask the boys, Mama." Polly's eyes were dancing. "Nid, here 's Mama, and she wants to know what you 're doing!"

Nid hurried up, a dripping brush in one hand and a smear of white paint across one cheek, followed by Laurie. The others

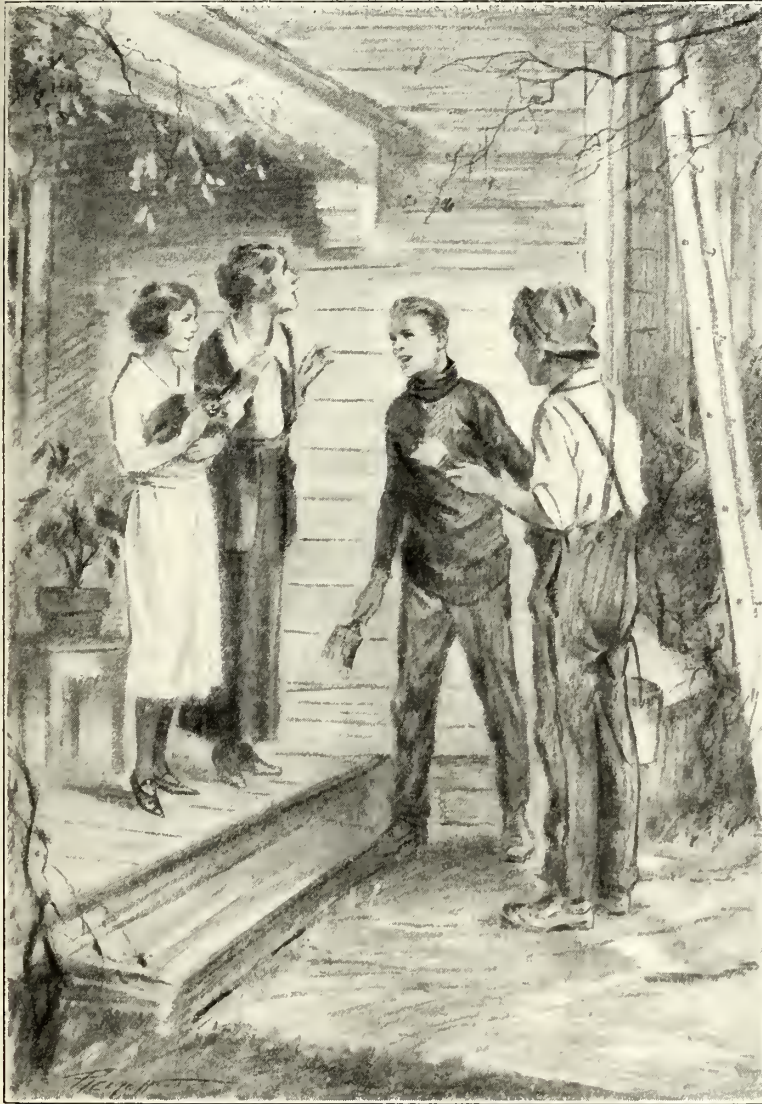

"BUT I DON'T UNDERSTAND, NID TURNER!" SAID MRS. DEANE, HELPLESSLY"

ing-room on the second floor, she was startled to see the head and shoulders of a boy appear outside her window. Her exclamation of alarm gave place to murmurs of bewilderment as the supposed burglar contented himself with lifting the two shutters from their hinges and passing them down the ladder to some unseen accomplice.

Mrs. Deane looked forth. In the garden



paused at their various tasks to watch smilingly.

"Painting the house, Mrs. Deane!"

"Painting the house! My house? Why—why—what—who—"

"Yes 'm. There 's the blue paint. It 's as near like the old as we could find. You don't think it 's too dark, do you?"

"But I don't understand, Nid Turner!" said Mrs. Deane, helplessly. "Who told you to? Who 's going to pay for it?"

"It 's all paid for, ma 'am. It—it 's a sort of Christmas present from us—from the school. You—you don't mind, do you?"

"Well, I never did!" Mrs. Deane looked from Ned to Laurie, her mouth quivering. "I—I don't know what to say. I guess I 'll—I 'll go see if any one 's—in the shop, Polly. Did you think you—heard the bell?" Mrs. Deane's eyes were frankly wet as she turned hurriedly away.

Ned viewed Polly anxiously. "Do you think she—does n't like it?" he half whispered.

Polly shook her head and laughed softly, although her own eyes were not quite dry. "Of course she likes it, you stupid boy! She just did n't know what to say. She 'll be back, after she 's had a little cry."

"Oh!" said Ned and Laurie in chorus, their faces brightening; and Laurie added apologetically, "Gee, we did n't want to make her cry, Polly!"

"That sort does n't hurt," said Polly.

Afterward Mrs. Deane said a great deal, and said it very sweetly, and the boys got more or less embarrassed and were heartily glad when she drew Ned to her and kissed him, much to that youth's distress, and the incident ended in laughter.

I 'm not going to tell you that the job was done as perfectly as Sprague and Currie, Painters and Paperhangers, would have done it, but you 're to believe that it was done much quicker and at a far less expenditure of money! And when it was finished, no one except a professional would ever have known the difference. Perhaps there was more blue and white paint scattered around the landscape than was absolutely necessary, and it always remained a mystery how Antoinette managed to get her right ear looking like a bit of Italian sky, for every one professed ignorance and Antoinette was apparently well protected from spatters. (It took Polly more than a week to restore the rabbit to her original appearance.)

When the early winter twilight fell and it

became necessary to knock off work for the day, the blue painting was more than half done and, unless weather prevented, it was certain that the entire task would be finished by the next evening. Mrs. Deane served five-o'clock tea,—only it happened to be four-o'clock tea instead,—and nine very, very hungry lads did full justice to the repast, and the little room behind the store held a merry party. Perhaps the prevailing odor of paint detracted somewhat from Mrs. Deane's and Polly's enjoyment of the refreshments, but you may be certain they made no mention of the fact.

That night the boys viewed the cloudy sky apprehensively. Laurie, who knew little about it, declared dubiously that it smelt like snow. But when morning came, although the cloudiness persisted most of the day, the weather remained kindly, with just enough frost in the air to chill feet and nip idle fingers and to give an added zest to labor. Very little time was wasted on luncheon, and at two o'clock the last slap of blue paint had been applied and the more difficult work of doing the white trim began. Fortunately, there were only eleven windows and two doors, and although "drawing" the sashes was slow and finicky work, with nine willing hands hard at it, the end came shortly after dusk, when, watched by eight impatient companions, young Haskell, one of the junior-class boys, with trembling fingers drew his brush along the last few inches of a front window, and then, because he was quite keyed up and because it was much too dark to see well, celebrated the culmination of his efforts by putting a foot squarely into a can of white paint!

When first-aid methods had been applied, he was allowed, on promise to put only one foot to the floor, to accompany the rest inside and announce to a delighted and slightly tremulous Mrs. Deane that the work was completed. There was a real celebration then, with more piping-hot tea and lots of perfectly scrumptious cream-puffs,—besides less enticing bread-and-butter sandwiches,—and Mrs. Deane tried hard to thank the boys and could n't quite do it, and Polly failed almost as dismally, and Laurie made a wonderful speech that no one understood very well, except for the general meaning, and nine happy youths cheered long and loudly for Mrs. Deane, and finally departed into the winter twilight, calling back many a "Merry Christmas" as they went.

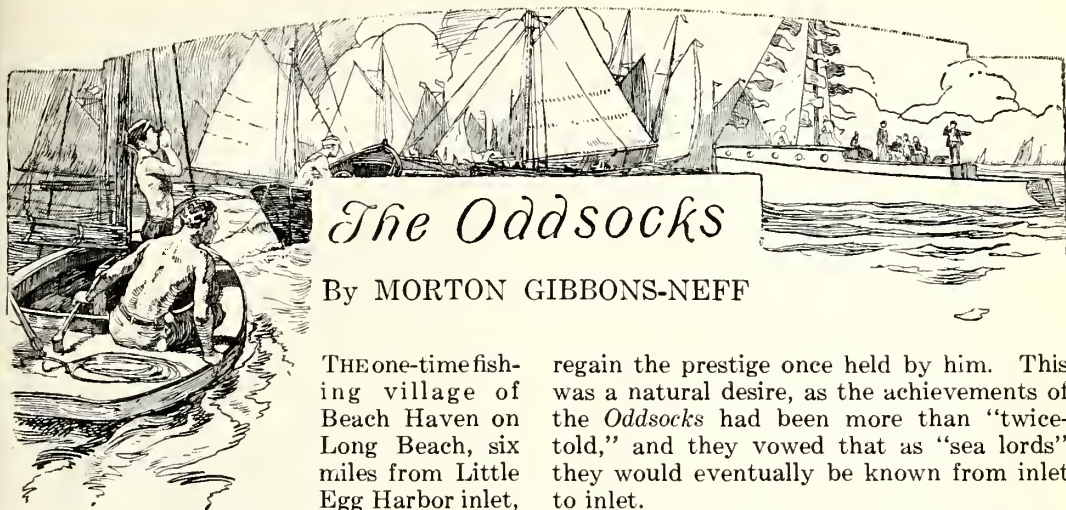

## The Oddsocks

By MORTON GIBBONS-NEFF

THE one-time fishing village of Beach Haven on Long Beach, six miles from Little Egg Harbor inlet, and now a summer

resort of no mean reputation, is possibly the most advantageously situated town on the Jersey coast for lovers of water sports. It is here that the racing of fourteen-foot gunning-skiffs, better known as "sneak-boxes," was conceived and to this day has been continued by both natives and cottagers.

In the late nineties, when a sneak-box was raced with only one sail and with no other preparation than a coat of stove-polish on her bottom, a lad by the name of Charles Griffin, then eighteen, built a "box" for the purpose of sweeping the honors of Tuckerton Bay, and the success of his endeavor is local history. The *Oddsocks*, a well-built fourteen-footer, for years showed her heels to all competitors, not only local entries, but to the ambitious mainlanders from Tuckerton, West Creek, Parkertown, and other bay-side communities, who annually tried to carry home the flag, which was then and is to this day symbolic of small-craft supremacy. Until 1900, her record, for the most part, remained unbroken; but with a new generation coming on, the design slowly changed, causing an increase in the sail area. This was too much for the *Oddsocks*. Griffin saw the "handwriting on the wall," and, being of an age when salt-water "duckings" and an occasional upset did not have the same appeal, he finally called an end to his racing days and housed the *Oddsocks* under his cottage, to rest on the laurels that she had won before competition made her obsolete.

"SUNNY" and "Toots" Griffin, sons of the redoubtable Charles, had taken up the racing game where he had left off, and were eager to

regain the prestige once held by him. This was a natural desire, as the achievements of the *Oddsocks* had been more than "twice-told," and they vowed that as "sea lords" they would eventually be known from inlet to inlet.

Boys of twenty and sixteen years respectively, they had been participating in the racing game for several years; but, try as they would, all endeavors to reach the pinnacle of success had met with failure. Their friends the Rackley boys, proud possessors of the *Tadpole* and *Bullfrog*, two of the fastest sneak-boxes on the bay, baffled their every attempt. Their own boat, the *Pelican*, was of fairly modern design, and, though fast in a good wind, was loggy in light air; and as the races of recent years had been held in the morning, before the usual afternoon blow set in, they invariably finished anywhere from third to seventh place.

At the end of the racing season of 1920, both boys realized that their ambitions would never be fulfilled by the *Pelican*. After much discussion, they finally decided, to the astonishment of their father, to rehabilitate the old *Oddsocks*. They took into consideration its antiquity, but, knowing her speed in light air, they figured that, with a bit of carpentry work plus a new set of sails, they would at least fare better than with the *Pelican*.

The winter months seemed longer than usual to the impatient boys. However, much of their restlessness was overcome in designing the new sails and engaging in other preliminary work of reclamation. When summer finally reappeared and the general exodus from the city to points along the coast began, the Griffins were among the first to leave. In previous years, the first few days after their arrival Toots and Sunny generally spent in looking up their old friends, but this year no one saw them except after sundown and then only for a brief time. There was some specu-



lation as to how they spent their days, but aside from being seen at the snugery, a boat basin one mile north of Beach Haven, and at times when occasional trips were made to the village hardware store, little was known of their whereabouts.

THE championship race had been scheduled by the racing committee of the Little Egg Harbor Yacht Club for Saturday morning, July 15; and though that date was still a week off, the cottagers young and old were waiting in eager expectation. Never in the memory of any one had the entry list been so large. Beach Haven was to be represented by fifteen sneak-boxes, while the mainland towns were sending over a fleet of nine, making a total of twenty-four boats in all. There was much discussion as to why the Griffins had not entered the *Pelican*, not because any one feared this particular boat, but Sunny and Toots were always counted on to swell the number of contestants; and to make matters worse, the boys were exasperatingly non-committal.

On the Friday night preceding the race, Sunny, unknown to any one except Toots, slipped into the committee-room at the clubhouse and added the *Oddsocks* to the long list of contestants posted on the bulletin-board. His entry was the twenty-fifth. With a feeling of satisfaction he left the room, knowing that within ten minutes tongues would be wagging and much speculation would be rife as to just what kind of boat the *Oddsocks* was, as surely no one would suppose she was the same old hulk sailed by Charlie Griffin back in '98.

SATURDAY dawned a typical summer day. With the sun well up and the heat on the rampage, all eyes were set for a light southerly wind with a taste of salt air, but the flags hung limp and not even a faint breeze stirred. Excitement, somewhat subdued by the seriousness of the work ahead, was prevalent among the crews of the contesting sneak-boxes. Although the time set for the race was still two hours off, sails of pleasure-craft were seen heading in from the west, each boat filled to capacity with backers of the mainland entries, while the cottagers and hotel guests were already showing signs of activity.

At the dock of the Little Egg Club, where the racers were moored, pandemonium had broken loose. The shouts of the crews resounded through the heavy, humid air. Every boat had been checked in except the

*Oddsocks*; and while some wondered where the Griffin boys were, few, in their excitement, gave vent to their thoughts, as there was too much to be done in the final "slicking-up" to worry about an old-fashioned phantom ship.

At the snugery two boys could have been seen stripped to their waists, hard at their work, with an occasional glance at an old watch, tilted against the side of the port wash-board.

"That finishes it, Sunny," said Toots, putting a final half-hitch on a piece of deck marlin.

"Yo, Jerry! bring your launch over; we're ready to go down." Jerry Prague, the boat-house tender of the snugery, in reply to the simultaneous beckoning of the boys, soon had a tow-line attached to the stern of the *Saucy Sally*, and the trip to the starting-line was under way. As they passed the yacht-club, a scant quarter of a mile from the starting-line, the much-looked-for southerly had sprung up, stirring myriads of sunlit ripples on the heretofore oily surface of Tuckerton Bay.

"Seems to me, Toots, that if this wind increases to a full-sail breeze, this old relic will at least have a fair chance to show that age has nothing to do with speed. The day could n't have been more ideal for our purpose."

"You're right," answered Toots; "but I certainly wish we had had an opportunity to try out this rig. It's a good fit, considering everything, but I'll be hanged if I know whether she's got too much sail ahead or aft, or whether she'll steer a lee-helm or keep driving into the wind. Rather important things to know about your craft, but we'll give her all she has, anyway."

It was n't long before Jerry cast off his line a few hundred yards from the judges' boat, which was bedecked with flags of all nations and carried a shining brass cannon aft for the purpose of firing the preparatory and starting signals. The moment the tow-line had been cast off, the jib and mainsail of the *Oddsocks* were set, and truly she looked well with her cream-white rig and new coat of paint. Just as though dim recollections of her past smote her wooden soul, she seemed to shiver and pause for an instant, then, under the guiding hand of Sunny Griffin, slid off to a half-sheet, slicing the water with her aristocratic bow. In a moment they were abeam the judges' boat, when Sunny eased the sheet and brought her up into the wind, her sails

fluttering and spanking, while her stays and halyards hummed to the accompaniment of the fresh southerly breeze.

"How 's the course, Mr. Rackley?" called Toots, cupping his hands to carry the inquiry.

"Cross the line south," came back the cheery reply, "round the can-buoy off Bond's, then north, northwest, through Long Point thoroughfare, and return."

"Same old course of ten miles," said Sunny, waving his thanks to Mr. Rackley, as he trimmed her in and headed east on the star-



"HOW SUNNY AND TOOTS GRIFFIN SPENT THEIR DAYS"

board tack. "The only thing I'm not awfully stuck on is this strong flood-tide. It means a long and grueling beat to Bond's, with short tacks on the flats to skip the tide, and, unfortunately, a comparatively short run with free sheet to the 'Point,' for, as Dad has often told us, this clipper does a merry tattoo on a beam wind and knocks 'em high when running free."

By the time the *Oddsocks* reached the flats, about a quarter of a mile from the stake-boat, the bay seemed literally swamped with sailing-craft of every description, miraculously dodging each other in their attempts to avoid collisions. The fourteen-footers, trim and natty, with sails that seemed far too large for safety, had all reached the scene, and while, some were tacking in and out among the sight-seeing "cats," many were content to lay to the wind, as if resting in anticipation of the long and hard contest.

Just as Toots was tightening up the peak halyard, a puff of smoke broke out from the

stern of the judges' boat, followed by a dull boom!

"There goes the first gun!" yelled Sunny.

Then, as soon as the smoke had cleared, the fight for position started. Twenty-five racers, each endeavoring to get away to a flying start, made a beautiful sight, zig-zagging here and there in an endeavor to secure a windward berth.

"Keep your eyes on your watch, old timer, for in another five minutes we'll be starting the job we've planned for eight months."

"Four minutes, three minutes, two minutes, one minute, thirty seconds," repeated Toots, at seemingly endless intervals. By this time, on bluffing about a Parkertown boat which was heading in on the starboard tack, the *Oddsocks* had obtained a commanding position; and just as the starting boom echoed across the water, the bowsprit of the octogenarian shot across the starting-line.

"We're off,—give her everything you have!" yelled Toots, trimming down the sheet until the mainsail looked like a flat expanse of ironing-board. Both boys perched to windward, with bodies flattened out along the cramped deck, wondered if they had n't undertaken the impossible to try and beat twenty-four up-to-the-minute racing sneak-boxes—but time for thought was limited—the fight had started.

The old boat was behaving beautifully. Careering, just so the water was lapping her lee rail, she stuck her nose into the fresh breeze with a vengeance.

At the slightest puff, Sunny's hand "ate her out" into the wind. She was pointing and footing well and seemed to be doing everything that was expected of her, when a hoarse bellow came from under sail, "Hard-alee!" As quick as a wink Sunny spun her around on the starboard tack, just missing a West Creek boat by inches. This unexpected manœuver placed the *Oddsocks* in semi-blanket and caused Sunny again to swing her on the port tack.

The entire fleet was hugging the flats closely, as the flood-tide had set in strongly and was racing up the bay at a four-mile clip. By the time Beck's farm was reached, they began to string out. Due to a forced tack plus a bit of sea-weed that was picked up by the center-board, the *Oddsocks*, although seeming to be



hard at it, was about twelfth, while the Rackley boats and the *Tabasco* were well to the front. A dapper little thirteen-ten box, hailing from Tuckerton and handled by George Marshall, had her nose to the front by a scant fifty feet and was footing it south as if propelled by an engine.

"Toots, ease off on that jib a fraction," said Sunny, as an unknown "box" began to lap the *Oddsocks's* stern to windward. Like a flash Toots responded; and though the stranger hung on, she ceased to gain. At Clam Cove, the half-way mark to the buoy, Marshall still lead, but was being pushed by George Rackley in the *Tadpole*. The fleet was stringing out more and more, but, due to sail alteration, the *Oddsocks* was holding her own and, in fact, had bettered her position by two and was going strong.

At 10.47 Marshall swung the outer mark, and immediately broke out his spinnaker. The *Tadpole*, four seconds back of him, did likewise. Then in the following order came: the *Tabasco* (B. H.), 10.47.59; the *Curlew* (Spray Beach), 10.48.00; the *Spanker* (Parkertown), 10.48.04; the *Isolde* (B. H.), 10.48.15; the *Virginia* (Tuckerton), 10.48.17; the *Bullfrog* (B. H.), 10.48.24; the *Alice* (West Creek), 10.49.00; the *Oddsocks* (B. H.), 10.49.10.

Every boat of the first ten around executed the turn with rare seamanship. In each instance the spinakers broke out a few seconds after the main-sheet was eased. The remaining fifteen boats were stretched out for some distance, but quite a few rounded the buoy within several minutes of the *Oddsocks*.

"Well, Sunny," said Toots, sitting in the cockpit with chin resting on the palm of his hand, "Marshall and the *Tadpole* have about a minute and a quarter on us by actual time, but nearer three minutes if the tide in their favor is counted, for we had to buck it for quite a while when they were running with it."

"You 're right, brother" answered Sunny, somewhat tired after his exhausting battle down the flats; "but remember, this craft is rated high before the wind, so if the 'dope' is correct, we should better our position a bit on the run up to Long Point."

Truly, the *Oddsocks* was in her element. With every inch of canvas drawing, save her jib which occasionally went flat on a cross current of air, she left a wake in her stern as if churned by a twin-screw power-boat. The *Perky*, a Parkertown boat, which rounded shortly after the *Oddsocks*, for a time threatened to blanket her, but by working to windward, Sunny managed to clear the danger and

it was n't long before the *Oddsocks* began to show a slick pair of heels. By the time Clam Cove was reached she had passed the *Alice* and was pressing the *Bullfrog* for eighth place.

The fair wind and strong tide soon had the leading boxes abreast of the stake-boat, where the spinakers were taken in and the balloon-jibs set, as the course was more quartering to the northwest. Unfortunately, the *Curlew*, on setting her balloon, lost the sheet of it, and the crew, on endeavoring to recover it, caused a grand and glorious upset, much to the disappointment of every one, as up to that time she had been sailing a splendid race. This automatically placed the *Oddsocks* in seventh place, as she had overhauled the *Bullfrog* after an exciting luffing match at the turn of the channel.

At 11.21.07 the *Tadpole* passed through Long Point thoroughfare leading the fleet. Then came the *Spanker*, Marshall, *Tabasco*, *Isolde*, and *Virginia* in the order named, with the *Oddsocks* but a stone's throw behind. Sunny passed the point at 11.22.00, or just fifty-three seconds behind the leading boat. This meant a net gain of thirty-four seconds on the run up from Bond's. Although this showing was not bad, in a sense it was disappointing, as they figured all "their powder" on this one leg. They certainly could n't hope to out-foot the leaders on the long drive back to the stake-boat, some three miles to windward. To make matters worse, as they cleared the thoroughfare, Toots discovered a bad leak at the base of the centerboard-well about a foot aft the mast-step. The water was coming in so fast that the pump, rather than the bailing-can, was resorted to. The necessity of plugging it with oakum caused Toots to crawl forward under the deck. This threw the *Oddsocks* off balance and, at such a time, was flirting with disaster. When the trouble had finally been remedied, they found they had lost about two hundred feet and once again had been overhauled by the *Bullfrog*.

The boys were desperate as they realized that only a miracle could save the day. As the tide was still running strongly the fleet was keeping well in on the eastern flats, resorting once again to short tacks to escape it.

There is a racing axiom that when a boat is falling behind, it is always advisable to spilt tacks, providing the skippers of the leading boats will permit such action. This was Sunny's chance. Without even saying a word to Toots, he kept on the port tack, heading directly across channel. When deep

water was reached the tide gripped the boat as if she were dragging ground. In an instant Toots yelled, "Put her about!" but Sunny paid no attention to the warning. For a period of about fifteen minutes they felt the

when we come about we shall be able to lay our course to the judges' boat, and at the same time will not buck much tide. Also, being so far to the west, we may pick up a southwesterly, which will let us ease the sheet before the line is reached. It may mean something."

The entire fleet evidently looked upon the Griffin boys' move with disdain, for not one of the twenty-three followed suit; in fact, the *Oddsocks* appeared to be sailing a race of her own. Not one of the cat-boats, following the race, came their way to wish them luck.

For a time the prospect looked very gloomy; for the *Tadpole*, Marshall, and the *Spanker* appeared to be making good headway and were fast approaching the finish-line. But just as things looked the darkest Toots saw the leading boats slow down, as if held in check by some invisible hand.

"Sunny, they're beginning to buck the north-flow eddies as they swing around the mid-channel buoy. Keep her going!"

To the followers of the race, the *Oddsocks* seemed entirely out of it. She was some distance to leeward, still on the port tack and growing smaller by the minute, while the remainder of the fleet,

especially the leading boats, were in plain view a short half-mile from the finish-line. A few loyal rooters for the *Oddsocks*, who occasionally directed their gaze to the west, saw the Griffin boat finally put about on the starboard tack.

All eyes were focused on the *Tadpole* and Marshall, who were having a gallant fight



"THE 'ODDSOCKS' SHOT ACROSS THE LINE—A WINNER BY TWO SECONDS!"

"drag" forcing them to leeward, but just as they were about despairing reaching shoal water before too much ground had been lost, the bow of the *Oddsocks* headed closer to the wind and the drag ceased. She had finally reached the west flats.

"I figure this way, Toots," remarked Sunny; "if we continue long enough on this tack,



for the lead, first one and then the other showing momentary supremacy. The *Spanker* and the *Bullfrog* were also close up, and threatened at any moment to gain the advantage. Excitement was intense. Closer and closer they came. The activity aboard the judges' boat indicated that the officials were preparing to time the contestants as they crossed the line. One hundred, ninety, eighty yards from the finish, battling the relentless tide—but still they came!

"Look!" cried a voice from one of the pleasure-boats. Every eye was turned to the point indicated, and there, in full majesty, with bellowing sails and glistening deck, the *Oddsocks* sped down on the finish-line from a point west-southwest. Would she make it in time? The *Tadpole* seemed to be only a scant five yards from the finish, moving slowly though steadily, with Marshall overlapping her stern. The *Oddsocks*, twenty yards to the west, headed from a point at right angles to the stern of the judges' boat, appeared to leap through the water. It

seemed too late; the Griffin boys were doomed to bitter disappointment, for Mr. Rac already had his hand on the lanyard of cannon and his eyes glued to the imaginary line. The tip of the *Tadpole's* bows slowly came within the line of his vision. Just then, the tide, with a vicious swirl, seemed to hold her suspended, and the fluky souly drove its blasts farther west and created a momentary calm in the vicinity of the *Tadpole*. The *Oddsocks*, favored by this fickleness, responded instantly to the puff of wind, and Sunny, seeing his chance, pushed the tiller hard to port, spinning the *Oddsocks* around with sufficient momentum so that she shot across the line—a winner by two seconds!

Everybody afloat that day will remember the wild scene that followed. The hilarious action of Sunny and Toots in diving overboard at the boom of the cannon, and the manly way in which the defeated skippers subsequently congratulated the winners at the club-house. Yes, it was a glorious and well-earned victory!

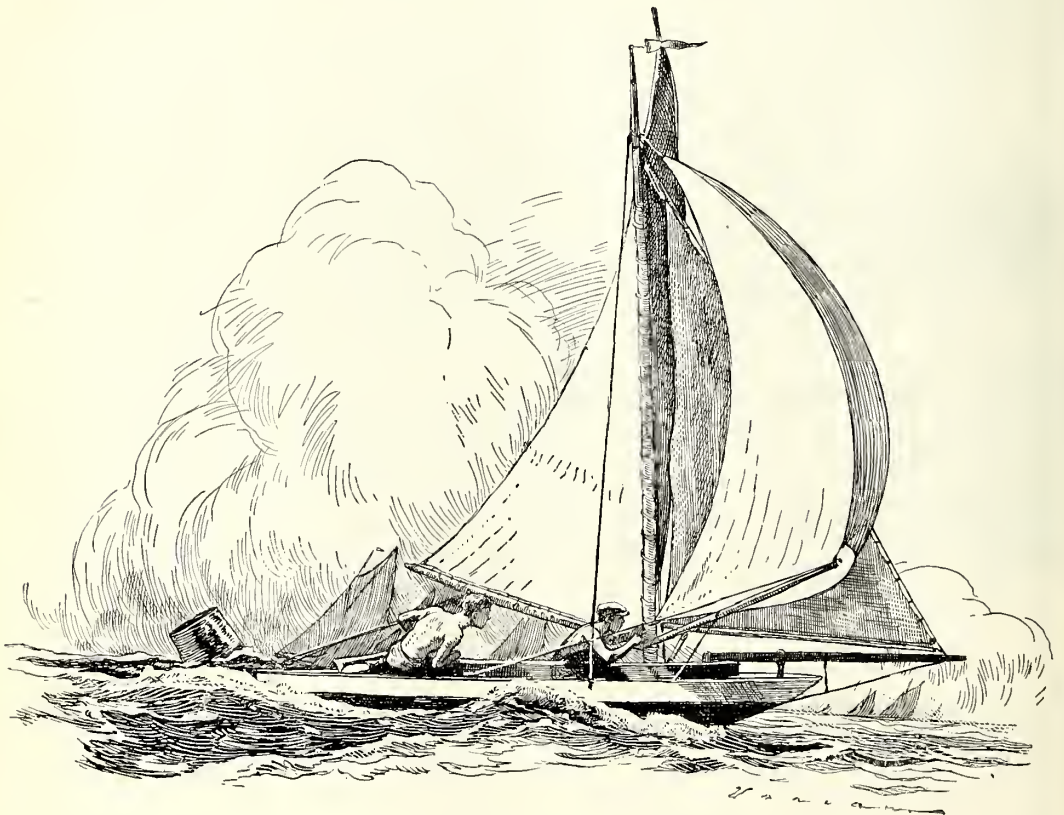

# THE INCA EMERALD

By SAMUEL SCOVILLE, JR.

*Author of "Boy Scouts in the Wilderness," "The Blue Pearl," etc.*

## SYNOPSIS OF PREVIOUS INSTALMENTS

PROFESSOR AMANDUS DITSON, the great scientist, has discovered the location of Eldorado, where for hundreds of years the Incas of Peru threw the best emeralds of their kingdom into the lake as an offering. The professor's ambition in life is to secure a living specimen of the bushmaster, the largest and most venomous of South American serpents. He calls on Big Jim Donegan, the lumber-king and gem-collector, and offers to lead a party to the lake if Jim will finance the trip, and to allow the lumber-king to have the emeralds, provided Ditson can keep the bushmaster. Jim promptly agrees to this, and Jud, the old trapper, Will, and Joe, the Indian boy, who together found the Blue Pearl for Jim Donegan, agree to go on the trip. Jud and Professor Ditson bicker as to who shall lead the expedition. A whip-scorpion decides the discussion in favor of the professor. They hear and see strange and beautiful birds in the forest, and Jud has an adventure with a black snake. They enjoy wild milk and honey, and Will studies the tropical butterflies, and at night vampire-bats break through the screen and he is badly bitten. The party travel by steamer to Manoa, the hottest city in the world. There they change to an Indian boat and travel down to Black River, which they enter by night, contrary to the Indian superstitions. Joe has a terrible experience with an anaconda, and Will is nearly swallowed by a giant catfish. They pass Treasure Rock and hear its story. Attempting to run the rapids of Black River, they are shipwrecked, and lose all of their equipment. They have an adventure by night with a jaguar, which Professor Ditson frightens away. Pinto, the Indian, makes for himself a blow-gun and the fatal urari poison; and under his direction, the party builds a new boat and starts on down the river. Pinto, Will, and Jud are treed by peccaries, Will is driven down to the ground by fire-ants, and his life saved by a sudden attack on the herd by a black jaguar. They come to the Falls of Urari, where the Slave Trail begins, which runs clear across the basin of the Amazon to the lost Lake of Eldorado. They meet a war-party of man-eating Muras. Joe turns out to be a blood-brother of the band, and receives from the chief the safe-conduct of the skin of the sacred Yellow Snake. On the shores of a forest lake they escape the attacks of three kinds of man-eaters, and Jud has a hairbreadth adventure with an alligator.

## CHAPTER IX

### THE PIT

FOR several days the treasure-hunters made their camp near the shores of the great lake, waiting for the slow healing of Professor Ditson's wounds. Here and there, through open spaces in the forest, they could see the summits of mountain-ranges towering away in the distance and realized that the long journey through the jungle was nearly over. Beyond the lake, the Trail stretched away along the slopes of the foot-hills, with plateaus and high pampas on one side and the steaming depths of the jungle on the other.

One morning, Professor Ditson felt so much better that Hen Pine, who had been acting as his special nurse, decided to start off on an expedition after fresh vegetables. Shouldering his ax and beckoning to Joe, for whom the giant black had a great liking, the two struck off from the Trail beyond the lake into the heart of the jungle. Before long, they saw in the distance the beautiful plume-shaped leaves of a cabbage-palm outlined against the sky. A full seventy feet from the ground, the umbrella-like mass of leaves hung from the slim, steel-like column of the tapering trunk, buttressed by clumps

of straight, tough roots, which formed a solid support to the stem of the tree, extending up ten feet from the ground. It took a solid hour of chopping before the palm fell. When at last it struck the earth, Hen cut out from the heart of the tree's crown a back-load of tender green leaves folded in buds, which made a delicious salad when eaten raw and tasted like asparagus when boiled.

As they turned to make their way back to camp, Joe saw something move on a near-by tree. Looking more closely, he noticed a crevice in the trunk, across which was stretched a dense white web. Behind this, crouched a huge spider. Covered with coarse gray and reddish hairs, its ten legs had an expanse of fully seven inches. The lower part of the web was broken, and in it were entangled two small birds about the size of a field-sparrow. One of them was dead, but the other still moved feebly under the body of the monster. Picking up a long stick, Joe started to rescue the fluttering little captive.

"Look out!" shouted Hen, who was some distance away. "That 's a crab-spider and mighty dangerous."

Paying no attention to the other's warning, Joe with one sweep of his stick smashed



the web and, just missing the spider, freed the dying bird, so that it fell to the ground. As he whirled his stick back for another blow, the terrible arachnid sprang like a tiger through the air, landing on the upper part of Joe's bare left arm, and, with its red eyes gleaming, was about to sink its curved, envenomed mandibles deep in the boy's flesh. Only the instinctive quickness of Joe's muscles, tensed and trained by many a danger, saved him. With a snap of his stick he knocked the spider flying through the air and into the underbrush.

"Did he get you?" shouted Hen, anxiously.

"I think not," said Joe.

"You'd most certainly know it if he did," returned the great negro, examining the boy's arm closely. Although it was covered with the loose, reddish hairs from the monster, there was no sign of any wound.

"That was a close call, boy," said Hen, carefully blowing the hairs off Joe's skin. "You am goin' to be mighty discomfortable from these here hairs; but if he'd done bit you, it might have killed you."

Hen was a true prophet. Some of the short, hard hairs became fixed in the fine creases of the skin and caused an almost maddening itching which lasted for several days.

The next day, for the first time since his meeting with the puma, Professor Amandus Ditson tried walking again. His left arm was still badly swollen and inflamed and his stiffened and bruised muscles gave him intense pain when he moved, but, in spite of Hen's protests, he insisted upon limping a mile or so down the Trail and back.

"If a man gives in to his body," he remarked impatiently, when Hen remonstrated with him, "he will never get anything done."

The second day he walked still farther, and the third day, accompanied by the faithful Hen, who followed him like a shadow, he covered several miles, exploring a path which ran through the jungle parallel with the Trail.

"Some one's been along here lately, Boss," said Hen, pointing out freshly broken twigs and marks in the earth.

"Probably the same hunting-party that we met before," returned the professor, indifferently. "They won't—" and he broke off his sentence at the sound of a little sick, wailing cry which seemed to come from the thick jungle close at hand.

"What's that?" said Hen, sharply, raising his heavy machete.

Without answering, the scientist turned off the trail and, raising the bushes, exposed the emaciated body of a little Indian girl about four years old. A tiny slit in the side of each nostril showed her to be a member of the Araras, a friendly tribe of forest Indians akin to the Mundurucus, to whom Pinto belonged. As she looked up at Professor Ditson, her sunken face broke into a smile.

"White man!" she whispered in the Arara dialect, which both Professor Ditson and Pinto understood. Then, pointing to herself with fingers so wasted that they looked like birds' claws, she whispered her own name, "Ala," the Indian name for those gentle, beautiful little birds which Europeans have christened "wood-stars."

The stern face of the scientist softened to an expression that even Hen had never seen there before. In spite of his injured arm, it was Professor Ditson who lifted up the little girl and carried her back to the camp. There the rest of the party found them when they returned with one of the plump curasows which Pinto generally managed to bring back from every hunt. From this, Hen Pine hurriedly made hot, nourishing broth, with which the professor slowly fed the starved child until she dropped off to sleep, holding tightly to one of his long gaunt fingers. Several hours later, the little girl woke up, seeming at first much stronger, and at once began to talk in a little voice faint as the chirp of a distant cricket. From her half-whispered sentences, the professor learned that her father and mother had both been killed in a foray of the Muras. Not many months after their death, Ala herself had fallen sick of one of the forest fevers so fatal to Indian children and had been abandoned by the tribe.

In spite of her starved condition, Ala was an attractive child. Instead of the usual shallow, shiny black eyes of Indian children, hers were big and brown and fringed with long lashes, and when she smiled it was as if an inner light shone through her wan, pinched little face.

At once she became the pet of the whole party, and although she, in turn, liked them all, it was Professor Ditson who always held first place in her heart. If he was long away from her, she would call plaintively, "*Cariwa! Cariwa!*" the Indian word for white man. Sometimes she would sing, in her tiny voice, folk-songs, which she had

learned from her mother, all about the wonderful deeds and doings of armadillos, agoutis, and other South American animals.

Before long, however, in spite of careful nursing, she began to sink rapidly. Then came days when she sang no more, but lay too weak even to taste the fruits that the boys were always bringing in to her from the forest. At last one night Professor Ditson, who always slept close beside her, heard a little far-away voice whisper in his ear,

buried her deep at the foot of a vast paradise-tree which had towered above the forest hundreds of years before the first white man ever came to South America and whose mighty girth will be standing when the last Indian of that continent has passed to his forgotten fathers. As Professor Ditson repeated over the little grave what part he could remember of the service for the dead, from the heart of the jungle sounded the deep, coughing roar of a jaguar as it wandered restless through the night.

The next day, camp was broken and once more the party followed the Trail through the forest. At first, the gloom and grief of the little Indian girl's death hung over them all. Then, little by little, the healing of the forest began to be felt. The vast waiting trees, the bird-songs, the still beauty of the flowers seemed to bring to them the joy and hope and faith which is the portion of wanderers among the solitudes and silences of earth.

The Trail still ran, a dividing line, between the steaming jungle on one side and



"THE OTHER BIRD STILL MOVED FEEBLY"

"White man, dear, dear white man!" and felt the touch of her hand against his cheek. A moment later, under the light of the setting moon, he saw that Ala had gone where there is no more sickness nor pain and where little children are safe forever.

Later on, when the rest of the party roused themselves before sunrise for another day, they found the scientist sitting grim and impassive in the star-shine, still holding the tiny cold hand of the little Indian girl in his. When old Jud found that clenched tightly in Ala's other hand was the shell of a tree-snail, all white and pink and gold, which he had given her days before, the old man broke down and sobbed as he looked at the peaceful little figure.

Under the light of Achernar, Canopus, and the other eternal stars which flared through the blackness of the tropical night, they

the plateaus and foot-hills on the other. Behind the latter towered range after range of mighty mountains, among whose chill heights were hidden forgotten Inca cities and the lost treasure-lake of Eldorado. On the mountain side of the Trail, the trees were set farther apart and belonged to families from the temperate zone, while here and there were small parks covered with short grass, with bare, treeless slopes beyond.

It was in such a country, after several days of travel, that Pinto, Jud, and the two boys started on a hunt, while the others made camp. They had been out less than an hour when the sharp eyes of the old trapper spied two strange animals feeding in an open space hedged in by thickets. They had long, banded tails, which clanked and rattled as they moved. Moreover, they wore armored hides, set with square plates



of bone and ringed around the middle with nine horny bands, while big pricked-up ears, like rabbits, and long sheep-eyes made them appear to the old trapper as among the strangest animals he had ever met.

"Armadillos," whispered Pinto, delightedly, as he too caught sight of them. "Spread out and we'll catch 'em both. Better 'n roast pig to eat."

In a minute the four hunters had made a wide circle around the unwary animals. It was not until they were close to them that the pair took alarm. Stopping their feeding, they suddenly squatted with their fore legs off the ground, much as a woodchuck might do. Instead of curling up like porcupines and trusting to their armor for protection, as Jud had expected them to do, they suddenly dropped on all fours and rushed and rattled down the slope toward the old trapper, like two small armored tanks, almost as fast as a rabbit would run. Jud was as much surprised as if he had seen a tortoise start to sprint. Going like race-horses, they bore down upon the old man.

"Hi! hi! stop! shoo!" bellowed Jud, waving both his arms over his head. "What 'll I do to stop 'em?"

"Trip 'em up," volunteered Will, from where he stood.

"Catch 'em by the tail!" yelled Joe. "Don't let 'em scare you."

In another minute they were upon him. Dodging his outstretched hands, their wedge-shaped heads plunged between his legs. Jud's feet flew up, and he sat down with a startling bump, while, rushing and clanking through the bushes, both of the armadillos disappeared in the depths of the thicket. The old man rose slowly and felt himself all over.

"I'd just as soon try to stop a racing automobile with my two hands as to head off a scared armadillo," he observed indignantly. "They got no right to run that way. Their business is to curl up an' be caught."

"Never mind, Jud," said Will, comfortingly; "you had the right idea, but you tackled 'em a mite too high."

That day, as they rested after lunch, Will wandered up toward the mountains, studying as usual his beloved birds. Along the pampaslike stretches of the plateaus and up among the hills, he found the bird-life very different from what it was in the jungle. It was Pinto who taught him the bassoon notes of the crested screamer, changing at

times to the long roll of a drum, and pointed out to him "John o' the Mud-puddles," the South American oven-bird, which, unlike the northern bird of the same name, builds a mud nest a foot or more in diameter, strengthened with hair and weighing several pounds. The birds mate for life, and have a quaint habit of singing duets while standing facing each other. Then there was another bird which Pinto called the "Firewood Gatherer," which built great nests of sticks in trees, dropping a wheelbarrow load of them under each nest. Of all the new birds, the boy liked the one called the "Little Cock" the best. These were ground-birds some nine inches long, with erect little tails, which stuck straight upward, and bristling crests on their heads. Looking like small bantam roosters, they scurried around through the brush, following the travelers inquisitively and giving every now and then a loud, deep chirp. Whenever Will would chase one, it would scurry off, chirping with alarm, but always returned and followed him through the grass and brush.

As the days went by, Professor Ditson became more and more uneasy, and, when camp was pitched, overtaxed his unrestored strength by hunting through dark nooks in the jungle and peering and prying among tangles of fallen trees or the rare ledges of rock which showed now and then among the waves of green. At last he told the rest of the party the cause of his anxiety.

"In a few days more," he said, "we shall begin to climb the foot-hills of Peru. Under my contract with Mr. Donegan, we were to collect a bushmaster before we began the search for emeralds. So I would suggest that we make our camp here and scatter out through the jungle until one of us is fortunate enough to discover a specimen of this rare and beautiful serpent. Let me beg of you, however," he continued earnestly, "to use the utmost care in catching a bushmaster. They are easily injured."

Jud's face was a study. "I will," he promised. "I'll bet there is n't any one on the continent of South America who will use any more care than me."

The next day the first hunt began. Armed with long, forked sticks, the six adventurers poked their way painstakingly through the thickest parts of the jungle, but without any success so far as bushmasters were concerned. Pinto aroused a fine specimen of a boa-constrictor, one of the smaller boas of



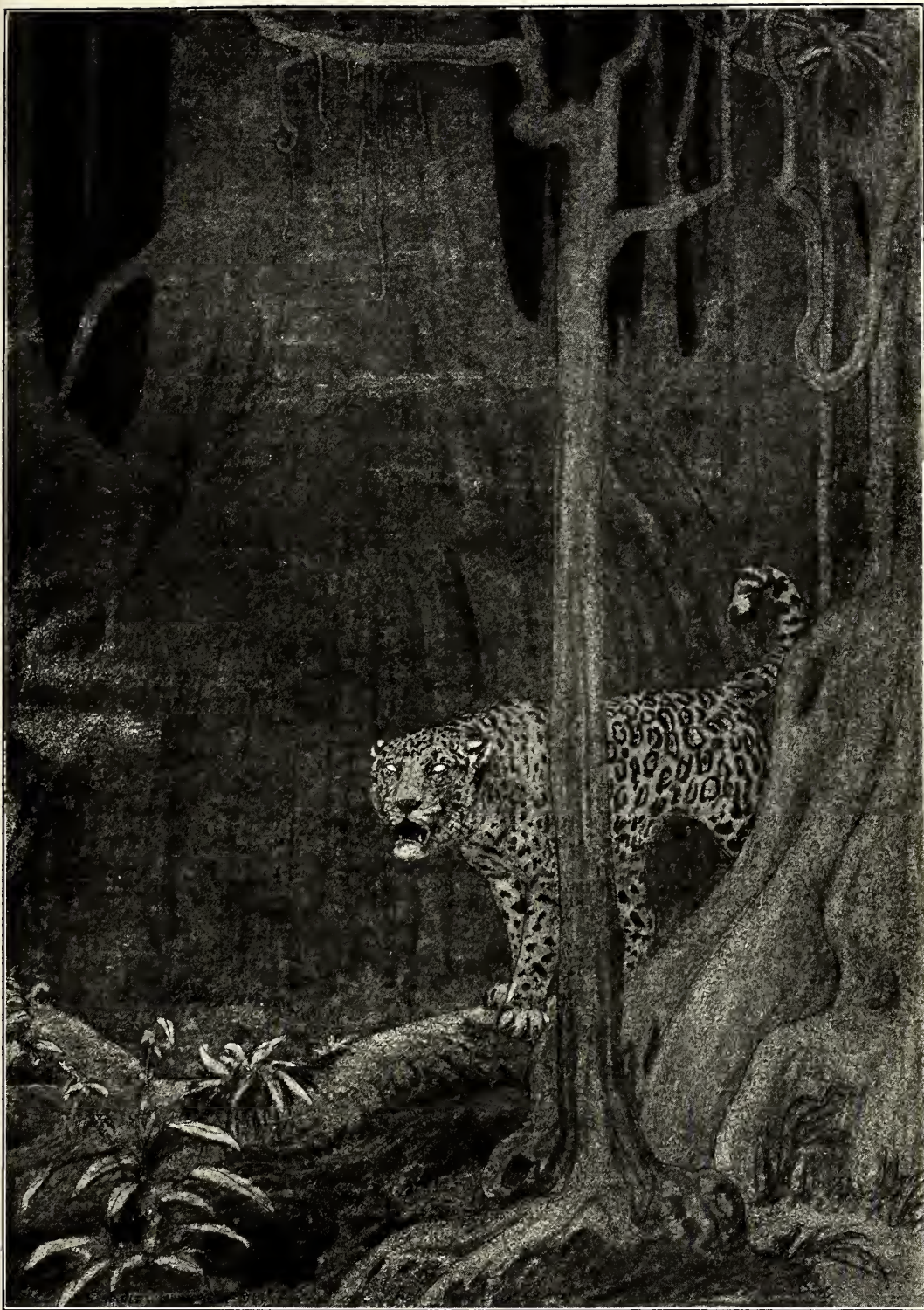

"FROM THE HEART OF THE JUNGLE SOUNDED THE DEEP, COUGHING ROAR OF A JAGUAR AS IT WANDERED RESTLESS THROUGH THE NIGHT"



South America, which flowed through the forest like a dark, shimmering stream. Jud scared up another hideous iguana, and it was a disputed question as to which ran away the faster.

Toward the end of the afternoon, Will found himself some distance from the others, following what seemed a little game-trail, which zigzagged back and forth through the jungle. At one point it led between two great trees, and there Will caught sight of a blaze on either side of the path. As he stepped forward to examine the marks more carefully, a dreadful thing happened. The ground from under his feet suddenly sank away without a sound, and the next moment he found himself at the bottom of a jug-shaped pit, some fifteen feet deep, whose sides curved in so sharply that not even a monkey, much less a man, could climb out. The opening had been covered over with the stretched skins of animals, stitched together and cunningly hidden under turf and leaves.

Although shaken and half-stunned by his sudden fall, the soft earth floor of the trap saved him from any serious injury. Far above he could see the light streaming in through the irregular hole which his weight had made in the covering which masked the pit. All too late Will realized that the blazes on either side of the game-path had been warnings for humans to avoid the pit-fall which they marked. The neck of the great earthen bottle was some five feet in width, but at the base it widened into a space fully double that distance across. As the boy's eyes became accustomed to the half-light below, he found that he could see the sides and the bottom of the pit more and more clearly and, scrambling to his feet, he started to explore its full circumference.

At his first step came a sound which no man born of woman has to hear more than once in order to stand stone-still—a fierce, thick hiss. Stopping dead in his tracks, Will moved slowly back until he was pressing hard against the earthen wall behind him. Even as he stopped, from the half-darkness before him, with a dry clashing of scales, glided into the center of the pit, with sure, deadly swiftness, the pinkish-yellow and black-banded coils of a twelve-foot serpent. From its eyes, with their strange oval pupils, a dark streak stretched to the angles of the mouth, from which a long, forked tongue played like a black flame. As the fierce head crested the triple row of many-colored coils, Will saw the curious hole be-

tween eye and nostril, the hall-mark of a deadly clan, and knew that before him was the king of all the pit-vipers—the dreaded bushmaster.

He stared into the lidless, fatal eyes of the snake, as they shone evilly through the dusk of the pit, until it seemed as if his heart would stop beating and icy drops stood on his forehead. He knew from his talks with Professor Ditson that bushmasters possess a most uncertain temper, and he feared that this one might instantly attack him. Once he tried to move to a point farther along the circumference of the earthen circle. At the first stir of his cramped muscles, the great snake hissed again and quivered as if about to strike. Will settled despairingly back, resolved to move no more; yet ever his thoughts kept running forward to the long, dark hours which were to come, when he would be alone through the night with his terrible companion. Then if, overcome by sleep or cramp, he should move, he feared horribly to be stricken down in the dark by the coiled death that watched him. Suddenly, as he set himself against making the least stir of a muscle, he heard from the jungle, clear to the broken covering of the trap, the same far-reaching whisper of death that had sounded when he was hunting with Pinto, and, with staring eyes, saw a black stream move sibilantly down the opposite wall of the pit, and realized that the blind, black ants of the jungle were upon him—and that there was no escape.

Slowly the head of the moving column approached the bottom of the pit, and Will remembered in sick horror how the ants had torn away shred after shred of living flesh from the tortured body of the agouti. As the insatiable, inexorable mass rolled toward him, the bushmaster seemed either to hear or scent its approach. Instantly its tense coils relaxed, and it hurried around and around three sides of the pit, lashing upward against the perpendicular walls in a vain attempt to escape. In its paroxysm of terror, it came so close to the motionless boy that its rough, sharp scales rippled against his legs. Only when the van of the ant-army actually reached the floor of the pit and began to encircle its whole circumference did the great serpent seem to remember Will's presence. Then, as if entreating the help of a human, it forced itself back of him, and, as the ants came nearer, even wound its way around Will's waist in an attempt to escape.

For a moment the fearful head towered level with the boy's face. Instinctively, Will's hand flashed out and caught the bushmaster by the neck. It made no attempt to strike, nor even struggled under the boy's choking grip; only the coiled body vibrated, as if trembling at the approach of the deadly horde. For a moment, the advance of the ant-army seemed to stop, but it was only because, in accordance with their tactics, the head of the column began to spread out until the base of the pit was a solid mass of moving ants and the black tide lapped at Will's very feet. Half-turning, and placing his ankles instead of his heels against the sides of the wall, the boy gained a few inches on the rising pool of death that stretched out before him, while the straining body of the bushmaster vibrated like a tuning-fork.

By this time, the opposite wall of the pit was covered and the whole circle of the base of the cone-shaped pit black and moving, except the little arc where Will stood. The ants were so close that he could see the monster heads of the leaders, and the pit was full of the whisper of their moving bodies flowing forward. Will shut his eyes and every muscle of his tense body quivered, as if already feeling their ripping, sheering mandibles in his flesh.

Just as the front line of the fatal legion touched his shoes, something struck him on the head, and he opened his eyes to see a liana dangling in front of him, while the light at the entrance of the pit was blurred by old Jud's head and shoulders. With his free hand, Will reached forward and seized the long vine, to find it ending in a bowline-knot, whose noose never gives.

"Slip it under your arms," called down the old trapper, hoarsely, "an' hang on! We'll pull you up."

It was only the work of a second to carry out the old man's instructions. Thrusting the loop over his head and under his arms, the boy gripped the tough vine with his left hand and, with his right, tightened his clutch around the unresisting body of the great bushmaster.

"I won't leave you behind for those black devils," he murmured, as if the snake understood, and tugged at the liana rope as a signal that he was ready to start. In an instant he was hauled aloft, just as the ants swarmed

over the space where he had stood. Fending himself off from the slanting walls with his feet, Will went up with a rush and through the opening at the top almost as fast as he had entered it. Close to the rope stood old Jud, with face chalky white as he watched the army of ants pouring down into the pit, while Hen, Joe, and Pinto, and even Professor Ditson, hauled with all their might on the vine.

Jud had become uneasy at Will's long absence and had tracked him to the entrance of the trap just as the army-ants reached it. His shouts had brought the rest, and it was Hen Pine who, with his machete, had cut the supple liana and knotted the noose which had reached Will just in time. Directed by Jud, his rescuers hauled on the vine so vigorously that the boy shot out of the pit and was dragged several yards along the ground before they knew that he was safe.

Jud hurried to help him up, but promptly did a most creditable performance in the standing-back-broad-jump.

"Bring your machete here, quick!" he shouted to Hen; "a bushmaster 's got the kid!"

"No," corrected Will, scrambling to his feet with some difficulty and waving off Hen with his unoccupied hand, "the kid 's got a bushmaster."

Professor Amandus Ditson was delighted to his heart's core.

"That is the finest specimen of the *Lachesis mutus*," he remarked, as he unwound the rough coils from Will's waist, "that has ever been reported. Whatever happens now," he went on, relieving Will of his burden, "the trip is an unqualified success."

"The man 's easily satisfied," murmured Jud, watching from a safe distance the professor grip the snake by the back of its neck and push it foot by foot into a long snake-bag which he always carried for possible specimens. When at last the bag filled with snake was tied tightly, it looked much like a long, knobby Christmas-socking. The professor swung it carelessly over his shoulder like a blanket roll.

"No snake ever bites through cloth," he remarked reassuringly. "Now for the Inca emerald!"

(To be continued)



# THE HANDICAP

By BREWER CORCORAN

HELEN COLSON ran from the tepee to flounce into her tent. "I begged and begged," she said, "but we 've got to take a papoose."

"Then we have," declared Bess Wilding, as if having a new girl for a tent-mate was no disappointment.

"And we wanted Jo Deering! It spoils our chance of being head tent this year."

"If we 'd got Jo, there would n't have been much competition," admitted Bess, slowly. "Her tennis, added to our paddling and your swimming, would have given us all the points for the cup. Maybe Miss Cameron saw that and is giving us a new girl as a handicap. But she 'll see that Jo gets one, too."

"She has," owned Helen. "Jo's mad, too. Now we 've got to fight against her instead of with her."

This time Bess laughed openly. "You 're a pair of old 'mug-hunters.'"

"You 've won two more than I," charged Helen. "You were just as keen about this scheme as Jo or I."

"And now that it 's wrecked, I 'm going to turn you into a trained seal. Instead of helping Jo, you 've got to beat her."

"But you 've got to play tennis; I can't dive."

"That 's why I 'm going to train you. You 're going to work and work. This tent 's going to win that cup if I don't do a single thing but keep you busy."

It was so like Bess that Helen began to smile. "Arrowhead 's a great camp," she declared, "and you 're the greatest old fraud who ever came here. What do you suppose our papoose 'll be like?"

"If I get my wish," owned Bess, "she 'll be about six feet tall. I don't want to paddle any races with you."

"You 'll have to."

"I 'm not going to weep until after my wishes fail."

"Have I got to fight your laziness as well as Jo's ability?" sighed Helen. "It 's too much of a handicap, even without having to educate some silly little papoose who does n't know that water 's wet."

"Maybe she won't be as bad as all that," comforted Bess.

"She 'll be worse! I feel it in my bones. She 'll be all ribbons and lace and fluffs and she 'll be afraid of spiders and sun-

burn and she 'll scream when a canoe tips. We 'd counted on Jo, and now we 're going to get a doll-baby as a handicap and I hate her already."

"I 'm sorry," owned a meek little voice from beyond the half-dropped flap. "Perhaps Miss Cameron will let me live with some other girls."

Helen gulped, gasped, sprang to her feet. "I—I—" she stammered. But Bess had already darted out. A second later she returned, her arm about the waist of their papoose.

Helen needed only one swift glance. Had she lived with her a year, she could not have described her future tent-mate more perfectly. She was all that Helen was not. Slight, graceful, almost unbearably pretty, with big deep blue eyes and gloriously golden hair. It seemed almost a crime to think of her laying aside her lovely clothes for the serviceable Arrowhead uniform.

But there was something so pathetic in the trembling lips, in the half droop of the shoulders, in the drag of the dainty feet, that Helen suddenly longed to do exactly what Bess was already doing. The papoose might not be an athlete, but she was certainly something that had to be loved and petted that very instant. "If you try to run away from us," Helen burst out impulsively, "you 'll find those pumps are no seven-league boots. I 've dreamed of girls like you, but I never hoped to have one for my very own."

"But I 'm not a doll," protested the papoose; "honestly I 'm not. I 'm—"

"Now forget what I said. I 'm an old bear who likes to growl before she 's hurt. Get her suitcase, Bess; then go to the store-room for an extra blanket."

For an instant the papoose looked at her out of those wide blue eyes. "Is it really cold in tents?" she asked innocently.

"Sometimes," Helen was removing her blankets from the best cot. "But we 'll keep you warm," she promised. "By the way, Baby, what 's your real name?"

"Amy Leeds. But," she added after a second's thought in which her lips began to twitch, "my father calls me just what you did."

Helen glanced at her. There was no

resentment here, anyway. The papoose was trying to be brave and game. And Helen could appreciate those things. Yet there had been a suggestion of quaver in the gentle voice which, somehow, gave her the impression that she was being laughed at. Yet when Amy sat down on the cot with a helpless little sigh, Helen dismissed the thought as absurd. The papoose wanted to be mothered. If Helen Colson never found a more disagreeable task than that, she felt life would be joyous.

But within a very short time, Helen found she was not to have her way in everything. Bess declared she also was a tent-mate of Amy's and, thereby, accorded full privileges and pleasures appertaining to the care, comfort, and petting of her whom they had already christened Babe.

Had Amy not been so entirely lovable, this "two-hens-with-one-chick" attitude would have become the joke of Arrowhead. As it was, most of the girls were ready to do quite as much, if not more, for the papoose. And Amy, after one day's struggle, surrendered helplessly. She could do nothing else. All that made the camp possible for her was a sense of humor so keen and subtle that it was entirely overlooked by her self-appointed protectresses. Had it not been for this, she might have been entirely spoiled, turned into a petulant, domineering, selfish little monarch over subjects who loved her not wisely, but far too well for her own good.

Even those who most envied Helen had to laugh when that worried swimming champion eased herself off the end of the wharf and looked anxiously up at the dainty figure above her.

"You probably can swim," she owned nervously, "but this water 's colder than the ocean, and I 'll catch you if you get frightened."

"All right." The next second the white arms went above the golden head and the graceful figure shot into the air—to twist into a perfect jack-knife dive. Helen, treading water, gulped a mouthful in sheer amaze. "Why did n't you say you were a wonder?"

she demanded. "Where did you learn to dive?"

"Oh, just places."

Jo Deering, on the float, could control herself no longer. "Hi, Helen," she called, "want me to throw you a life-preserver?"

Helen was off at racing speed. "You 're going to need one yourself," she promised.



"'I 'M SORRY' OWNED A MEEK LITTLE VOICE"

It started a sprinting race between float and wharf which Helen so needed for practice. Panting, they at last pulled themselves up onto the boards. "Maybe Babe 's a speed marvel," suggested Jo, wickedly.

Helen started to answer, thought better of it, and looked down at Amy, floating at their feet. "Do you know the crawl?" she demanded.

"Not a single little crawl," Amy smiled up at her. "All I know is the trudgeon and things."

"Is that all!" Jo's voice sounded heavy with disappointment, but her eyes danced. "Then Helen is n't out of a job, after all."



But Helen pushed her into the lake, ducking her twice to teach her proper manners; and before their private whirlpool had subsided, Bess had shepherded Amy back to the tent to dress for dinner.

Some of the old girls, who had had experience with Helen Colson's rather quick temper, wondered what would occur when she finally stalked tentward. But they did not know Helen half so well as they thought. As she entered the tent, she went straight to Amy. "Would you like to work up your diving and enter the contest next month? Bess is the only one you'd have to beat, and she'll help you."

"Of course I will," agreed Bess. "It's all in the tent, anyway, and Amy's better than I this minute. Who says we need Jo Deering?"

"No," announced Amy, promptly. "Do you think I'd do one single thing to disappoint either of you after all you've done for me? I won't go in the water again this summer if you talk like that."

"Oh, now, now!" laughed Helen. "I only suggested it 'cause I thought it might please you."

"It would n't please me to try to beat one of you, even if I could. I'm sorry I made that silly dive. You both think I'm such a helpless baby that I thought it would be fun to show you I could do something besides drown."

Helen threw one arm across Amy's shoulders. "Don't take it that way; please don't! You're exactly what we both want you to be, and it was a dandy joke. You need n't do a thing you don't want to do. Having you as a tent-mate is all Bess and I ask, and if you don't want to go into the contest, you don't have to. We'll take care of all that, and we'll take care of you and not let a girl say a thing to you about the tent's winning the cup or anything. Jo can have the old thing; Bess and I are satisfied with what we have now."

"We certainly are," Bess echoed. "And, even as it is, I believe we can win the cup for the tent anyway."

"Does it really mean a lot to you?" Amy asked suddenly.

For a second the two looked at each other, then turned to gaze into the troubled little

face. "Not half so much as some other things," retorted Helen, carelessly. "Oh, there's the dinner-gong!"

Amy went out, her brain in a whirl. She did n't know what to make of it all; she had n't the remotest idea what to do. She had never had any girl friends before. She knew these two had become real friends, but she had a dreadful suspicion that they were trying to make up, through kindness and tenderness, for the most unkind thing that had ever happened to her. Yet she had forgiven them that as completely as she had tried to let them accept her at their valuation. Now they appeared anxious to sacrifice themselves for her. She bit her lip and, because she had really grown to love them, decided she could make an equal sacrifice.

For that reason she settled down into a sort of tame butterfly existence at Arrowhead. Because she was always sweet, always happy, always ready to enter into any plan, her popularity grew. Nor did she taste bitterness again during that first month. When Helen won the swimming championship, none was so pleased as Amy over the tent's first leg on the cup. But anguish quickly followed joy. Jo Deering won the tennis tournament. Yet Amy's sorrow was really over Bess's disappointment at failure.

"Ought to have worked harder," mumbled the defeated one. "I've fallen down once; hope I don't do it again in the canoe-race."

"It was n't your fault," comforted Helen. "You knew you did n't have much chance. And we will win that race to-morrow. You can't beat this tent as long as we have Babe as a mascot."

"I wish—" Amy stopped abruptly; "I wish Jo'd sprained her silly old wrist," she finished lamely.

It was so like her, they had to laugh. But an hour later their laughter was a thing forgotten. Bess, romping with the crowd before the dining-tent, had slipped, fallen, and sprained her wrist. "Oh," she moaned, when they had finally got her to her tent, "how could I have been so clumsy and thoughtless!"

"What do you mean, dear?" Amy cuddled the injured hand against a soft cheek.

"The race to-morrow. I can't paddle now, and we had such a good chance. Oh,



"I'LL CATCH YOU IF YOU GET FRIGHTENED"

Babe, it means Jo's tent will get the cup and our names won't be on it at all."

The slender girl rose suddenly and faced her sorrowing tent-mates. "Does that cup really mean so much to you?" she asked quietly.

"Of course it did," groaned Helen. "All three of our names would have gone on it, and you were going to keep it for the tent till next year. We'd planned it as a surprise for you, but now Bess has spoiled it all."

"I did that when I lost the tennis tournament," gulped Bess. "It was going to be such fun, Babe! We'd planned a presentation ceremony and everything."

Amy looked from one to the other, her face white. "I—I did n't—" She stopped, her hands clenched into hard little fists. "It's just like you both," she said at last. "I've been nothing but the handicap you said I'd be, but I've done my best to be the thing I thought you wanted me to be. Now I'm going—"

"You're not a handicap!" Bess half sobbed. "You're the dearest thing that ever was."

"I've made friends, but I have n't made good for those friends," said Amy, evenly. "We're going to have that cup."

"But we can't get it now, Babe. Bess is out of the race."

"I'll take her place."

Bess gulped aloud, and Helen's face went white with real pain. "But, Babe," she explained gently, "you have n't touched a paddle since you've been here. Racing takes a lot of strength."

"I can try."

Helen drew a quick breath. The little face was so anxious, the big eyes so eager, the sweet lips so pleading, that she took the plunge. Amy wanted to try to do her share. Their own real disappointment was behind them now. Helen was not one to bring sorrow to one she had grown to love. "I'd like to paddle with you," she said without a quaver, "and all the girls will think it fine in you to take Bess's place. But it's a half-mile race, and a half-mile is a long way in a racing canoe, Babe."

"And you don't want people laughing at me," Amy exclaimed, suddenly flinging her arms around her. "Oh, Helen, if you won't believe I can do a single other thing, you do know I love you because you're so utterly loyal."

"I'd like to see any one even try to smile at you," mumbled Helen, to cover her real feelings.

"Then you're going to let me take Bess's place?"

"It is n't a question of letting, Babe; I'd love it." She meant it, every word. Cup, humiliation, nothing mattered now except that Babe must be given her own sweet way. "You stay here with Bess and I'll go and change our entry. Who says," she called back with a laugh that almost broke, "our tent won't win the cup!"

A protest, half pity, half amazement, started when Helen explained the situation to Jo and the rest, but she checked it in a flash.

"Babe wants to paddle," she said sharply, "and it's mighty game in her."

"I'll say Helen's the one who's game," Jo declared, as her rival stalked away. "She's the best waterman at Arrowhead, and it's going to hurt awfully to lose that race as they'll lose it."

Helen, as she went back to her tent, racked her brain for some way to prevent that same defeat. She knew it would be impossible for a novice to set the stroke. She even thought of carrying her as a passenger, but that would hurt Babe's pride, and, worse still, show that she had no confidence in her. No, the only way was to let her alone, permit her to do what she wished, and accept the consequences with a smile.

She thought Amy would want to discuss the race, and was never more surprised than when she refused to talk about it. "It'll only worry Bess," she explained, "and things will be all right somehow. They've been that way for me ever since I've been here. You've tried to make me feel I'm not a handicap; please don't make me think I am one now, Helen."

So Helen set her teeth, even when Amy refused to examine their canoe the next morning. But just before the hour of the



"ALL RIGHT"



race, Helen had her first shock. Babe picked out a pillow and started toward the lake. "What are you going to do with that?" she demanded.

"Just make myself comfy in that old canoe thing."

Helen gulped twice. "Oh!" she managed to say at last.

But Amy merely laughed. "Come along!" she called. "I want to find just the nicest paddle there is."

What was ahead loomed before Helen in all its horrible reality. A cushion and the "nicest paddle" for a real race! She had n't the heart to watch Babe pick out that "nicest paddle." Instead, she went to their canoe and a moment later Amy came dancing up.



"BABE STOOD A MOMENT HOLDING THAT AWFUL CUSHION"

"All ready?" she asked. "Now, Helen, stop worrying. If we tip over, I 'll get ashore; if we don't, you take that cup when Miss Cameron hands it to us."

"We have n't got as far as the finish yet, Babe. Take hold of the gunwale. And don't get your feet wet!"

"I 'll be careful. All right?" It was launched in a second, and Babe stood a

moment holding that awful cushion. Then it was plumped down in the bow, and a startled cry broke from Helen's lips as Babe stepped carelessly after it. But before she could warn her of the treachery of canoes, the knees were on the cushion, the straight little back resting lightly against the brace, and the Amy Leeds she had known for a month seemed suddenly to have been transformed, even before a gay "*Allons, Mam'selle!*" rang over the water.

"You—you—'ve been in a canoe before. Why did n't you tell me?"

"Why did n't you ask me?" The paddle poised, bit, there was a quick swirl in the water, and they were gliding up the lake.

"But you paddle like an Indian!"

A soft, pleased laugh came wafting back. "Why should n't I?" Babe asked. "Injun, she maak me de teach. De rivier, de rapide, de lac, she wan an' de same t'ing to me, Mam'selle."

"Oh, Helen!" Amy cried, "I love it so, being in a canoe again. Dad said I was getting to be nothing but a voyageur. That is why he sent me here—to be civilized."

But the starter's "Ready?" cut off Helen's thousand protesting questions. At her side she saw Jo, a queer look on her face, and on the other side, Frances, equally curious. "I don't understand it myself," she said.

"Go!"

There was a swish as the twenty paddles caught the water, a cry from far down the lake as the canoes leaped forward. Helen, swinging in perfect time with the lithe figure before her, felt a sudden relief, as if all responsibility had been lifted from her shoulders.

A hundred yards, and she was conscious of the golden head turning to look at the other canoes. The stroke fell off a trifle. "We 've got to beat Frances."

"You mean Jo."

"I mean Frances and Bab," repeated Amy. "They 're the better pair. Jo won't last." "Don't talk."

Again the gay, fluttering laugh came wafting back. "Maybe, yes, you lak eet should I sing, moi—de chanson wheech ole Pierre an' Injun Joe she sing whil' we maak de race pour la cabine chaque soir?"

"This is no joke, Babe. Look out!"

"I 'm watching." The rhythm never changed, but the long, swinging stroke lengthened a trifle. The creeping bow of Jo's canoe seemed to become stationary again. Fifty yards more and two canoes



"TWO MORE! ONE! LET HER RUN!"

began to trail. But Frances and Bab hung tight, and, as Amy watched their perfect swing, the laughter began to die in her eyes.

Half-way, and three canoes were far out in the van. Jo Deering had gaged the possibilities of Helen and Bess, but this new combination was a far different thing. Nor had she given Bab and Frances a thought. They had practised far up the lake and were ready to reap the harvest at her expense.

Now from the finish-line they could hear the excited cheers. The girls there knew something unexpected had happened. It was Bess who first recognized her tent-mates.

"It's Babe!" she cried. "It's little Babe!"

"Frances! Bab!"

"Jo's beaten. Oh!"

"Steady in the stern!" warned Amy. She had felt the canoe quaver in its forward rush; knew only too well what it meant to have it run out of balance. Frances and Bab had trained to make it a runaway race. Already they had carried Jo beyond the breaking-point. Was Helen weakening?

Amy's paddle did not vary in its reaching, greedy sweep. But her golden head turned. Bab's set face was not six feet behind. She

saw the water swirl and boil under the bite of her stroke; knew she, too, must spurt.

Her own arms were wearying. Had she had proper practice, it would have been a different thing. But now her lips were dry and the laughter gone from the blue eyes. She settled grimly to her work. The next she knew, Bab was not behind them but matching stroke with stroke at her elbow.

"Helen! Babe! Spurt, Bab!"

Amy heard the cries distinctly now. The finish was only just ahead. But it looked a very long way off. "Stroke!" she called sharply, and dared answer spurt with spurt. But Bab did not drop behind.

The small white teeth set as the paddle bit viciously to twist, flash, reach, and bite again. Bab, too, took chances now. It was the killing race Frances had planned to make. They had what they had wanted at hand; could they grasp it?

"Come on! Come on!" The girls at the finish were beside themselves. Arrowhead had never seen such a race. The old record was so badly smashed it would not even be a relic. "Babe, paddle!" pleaded Bess.

Amy thought that now she could see Bab's back. Were she and Frances stealing ahead?



They must be. Her skill had not been the equal of her desire. She was going to fail. The blue eyes blurred at the thought. Then, from behind that blur, rose a vision. A narrow lake, the virgin forest on every side, the peace of the still, chill evening; ahead, a cabin perched on a half-cleared promontory, and, in its doorway, the lank figure of old Pierre, staring lakeward, a queer, new expression on the weather-tanned face, an expression half of disbelief, half of pain—a look which told he saw a thing he did not wish to believe. And he was watching a girl in a canoe, a girl to whom he had taught the courage of the wilderness way, a girl who had never failed him before, but who was wavering now in her first great test. Of a sudden the blur lifted. Amy's head went up. Ahead, she saw the judges' boat.

"Now spurt!" she cried.

Helen called on every ounce of her reserve. Ten quick strokes, and the canoes were shooting bow to bow. "Spurt! Spurt!" Amy's voice had the urge of a whip. But they could not gain an inch.

Fifty yards ahead was the finish and pandemonium. Even Miss Cameron was bending far forward in the judges' launch. The little substitute was forgotten, the prize unconsidered, the trailers unnoticed, the coming record unthought of—only the climax of that desperate, killing race counted.

Amy could do no more. She knew she was giving all she had to give. There was the merest swing which told her Helen's stroke was losing its power. Babe might hold the tie; she could not break it. She dared to quicken her time, but dropped it down again after five flashing strokes. Helen had not been able to support her.

Of a sudden she heard a sharp cry. It was Frances, calling on Bab. In a flash, Amy understood. Bab was faltering. The pace she had set was demanding its price. Babe caught a quick, gasping breath. It was forty yards now on grit alone. Practice and experience had played their parts. The finish was a question of courage.

"Babe! Babe!"

Again it was Bess who pleaded. Amy heard her cry. Her back straightened and her paddle dug. The girl was calling to her tent-

mate to bring victory home—the girl whose place she was filling, the girl who had planned and worked and hoped to bring that cup to their tent for her. Over her came surging a new and greater need to win. It was not for herself alone she strove, but for the three. "Follow stroke!" she panted, and threw loyalty into the balance.

Thirty yards to go—twenty. Bab still clung desperate to her side. Five yards more, and the perfect rhythm of the four flashing paddles broke. "Now!" Amy's voice rasped. But her stroke stung the swirling water. "Now! Now!"

Helen, her head swaying, her eyes blind, tried to respond. Five more strokes and it would be over. Could she last?

"Stroke!"

"Helen! Amy! Frances! Come on!"

"Bab, oh, Bab! They've won!"

"They have n't. It's Bab!"

"Stroke!" It was little more than a gasp. Amy was furnishing more than half the drive, all the grit. "Two more! One! Let her run!"

For an instant the paddles trailed, then, slowly, were swung inboard. All about were cheers, as excited, as that wild, game finish. "Babe! Babe!" screamed Bess, and fifty girls tried to drown her joy in their delight.

But Helen drew quick, sharp gulps of breath. Already Frances and Bab had brought their canoe alongside. They tried to smile through parched lips. Down to the finish paddled Jo, a poor third. "Who won?" she panted.

"We did." Helen straightened slowly as the full meaning of her words sank home to her. "Oh, Babe!" she gulped. "We—you've won the cup."

"Go and get it," urged Bab. "Miss Cameron's calling you."

"Let's get Bess first," Babe said quietly. "I'm just taking her place, you know."

Helen laughed. "Yes," she agreed, "I know all that. You've been nothing but what I said you'd be—a handicap! Can you do anything else?"

"Oh, no," answered Babe, soberly, "nothing but get that cup for Bess and then get back to the tent. I don't much like this sort of thing. I'd rather be—be just a handicap."



# THE YOUNG COWBOY OR DON'T TIE YOUR LASSO!

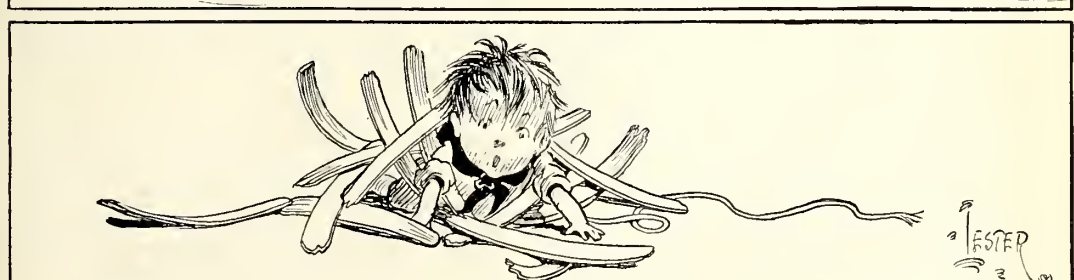
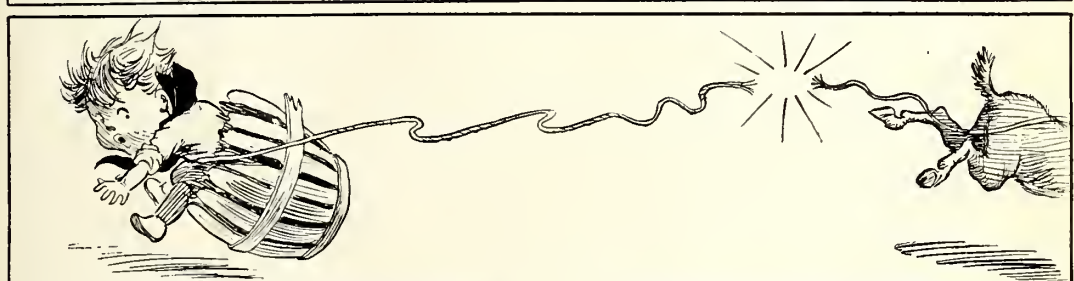
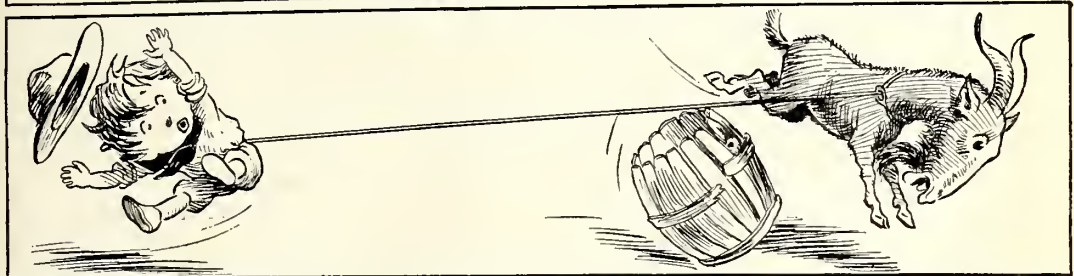
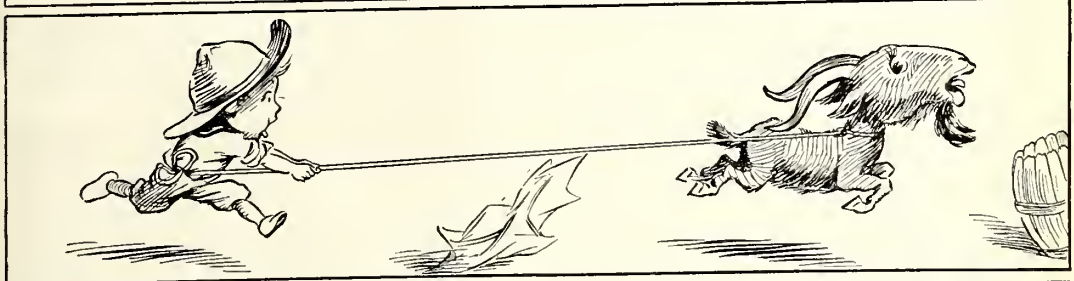
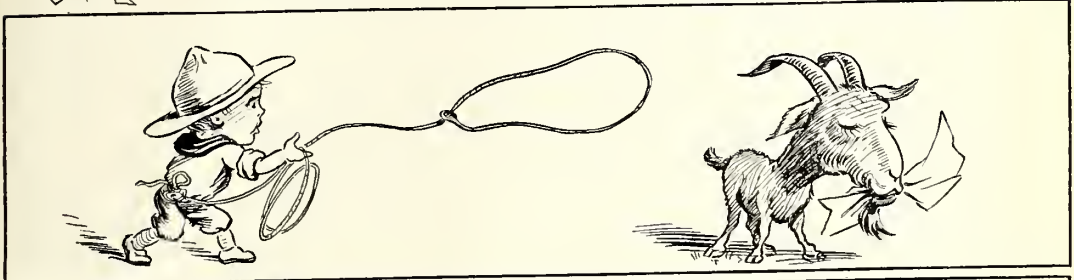

ESTER  
2



# IN THE BLOOD

By KENNETH PAYSON KEMPTON

## PART II

THERE was no sleep for Sam for a long time after that. For what seemed years he lay there in his burrow, staring into the dark, hearing the whispering voices of those two somewhere near him, as they laid their plans and made crude preparations for the voyage. In his own mind, there was no plan, although he cudged it for a sound one. This strange development might very possibly simplify matters; on the other hand, it might complicate them hopelessly. It would be better not to count on anything; to trust simply to any loophole emergency might offer.

"Finley lays t' make a haul on that fur," he heard them whisper. "Ain't I told you?"

"Yuh, you told me," came the sleepy answer. "Leave me get a snooze. They'll be none for me oncet we gets outside. I gets sick as a cat."

A vague bustle was beginning overhead. Sam heard the creak of new cordage, stampings up and down the deck, two shrill blasts of a towboat's whistle, and the *fuff-fuff-fuff* of her steam exhaust. The narrow rectangle that was the hatch showed now a ghostly gray; and through it once came his father's resonant voice, though strangely muffled, as if from a tremendous distance—"By, Mother—worry—home soon."

She would be standing on the pier end—that he knew, because many times before he had stood there with her. He knew how sickly gray the whole world looked outside; and how his father would stand on the *Etta's* weather quarter, and wave until the mist swallowed him, wave back at an answering red Paisley shawl that had waved and weathered twenty partings. A great lump rose up in Sam's throat and would not down.

With a hollow bang, they shut out overhead that narrow space of twilight. Men were running up and down as if the ship were afire. A slow, even, and rhythmic lilt and sway told him they were past the Light and standing into the open. And a gentle snore from somewhere very near reminded him that he was not alone in that funereal, floating vault.

Sam's eyes began to close in spite of him. Even the consciousness of his bedfellows grew less and less important. He insisted that he *would* stay awake, to let no oppor-

tunity slip that might arise. But sleep caught him in the middle of his vow.

He awoke to a tremendous hunger. Half dazed, he thought himself in the little attic room at home, and commenced to yawn and mutter and stretch comfortably. Then stark reality returned to him; and he lay in panic-stricken silence for a while, dreading the sounds that would tell him he had made his presence known to those two over there somewhere. But he heard again their heavy, even breathing. And the pangs of hunger gnawed him.

He shifted his position cautiously; confinement in that sand-hole cramped him. As he did so, his shoulder rubbed the floor above it, and he felt the board give!

Here indeed was a windfall! He stealthily tested other boards and found the butt-ends of them loose. He remembered, then, hearing of the custom: the men forward, having only scanty storage-room in the crowded forecabin, appreciate direct and easy passage to that ballast space beneath them. A bonanza indeed! For through the narrow crack his shoulder had made, came now the delicious warmth of the forecabin, and, floating on that warmth, a pungent, glorious smell of coffee and good beef stew!

For some time he lay listening, his head drawn in and under like a turtle's, his ear to that crack. He heard the tired breathing of sleeping men; knew they lay ranged in their bunks on each side the forecabin. Then a clock struck eight bells swiftly. And two men came stamping down the companionway from the deck.

They stood about interminably, pouring coffee (he heard it bubbling ecstatically from the pot!) and drinking it and talking. One observed that it was a great old night. So then Sam knew that he had slept the clock well nigh around—that it was just past midnight, and these two were coming down off watch—that the *Etta Deering* was already twenty hours on her three-day maiden sail.

They had to have their smoke before turning in, and they set about it leisurely, while the boy's mouth watered with the savor of that most enticing food. But finally he heard them kick off their boots and clamber into bunks. And soon after that, their own snores joined the chorus.

Then Sam got himself up on one knee. Feeling every inch of the way, he raised two board ends with his head and shoulder. By a mercy, nothing creaked or cracked or jarred. His upper body wormed into the dim-lit forecandle, right alongside his friend the stove; and with a final squeeze, he wriggled through.

He stood up and looked about him. On the stove there stood, beside the grime-scarred coffee-pot, a large kettle half-filled with a gently simmering stew; and fastened to the bulkhead just abaft the stove hung a large open cupboard, the lowest shelf of which held cups, a half an apple pie, a plate of formidable doughnuts. Sam smacked his lips, and immediately clapped a hand to his offending mouth lest some one should have been awakened.

Here was sound evidence that Henry Latham knew a ship's cook when he saw one. Here lay solid sustenance for a dozen midnight "mug-ups," should occasion or deep-water appetite demand.

The boy knew it; and he blessed the unknown, slippered, aproned, shaved, and greasy seaman's friend who had done this noble thing—blessed him and fell to, silently, like a wolf—for he was ravenous. No thought of the honesty involved assailed his conscience. In the first place, it was his father's ship; it was next door to his mother's pantry, whose huge doughnut crock and cake-box had always, figuratively speaking, been left ajar. In the second, and more important, the necessity of his goal—to reach Waite's office alive and soon, to bring evil to book and help law and justice to triumph—this imperative urge had obliterated almost every other thought from his mind. If a greater theft seemed necessary to the success of his plans, Sam would have made away with more than stew and doughnuts!

As it was, he had two huge mugs of scalding stew and the half of the apple pie. Then, as he was preparing for retreat, it occurred to him that he might possibly not get another chance, so he filled his pockets with doughnuts, leaving the plate as clean as the back of your hand. Whereupon, heaving a grateful sigh, he stooped, with natural difficulty, and began his return.

He had to go head first—there was no room to turn in his burrow. This made the matter rather difficult, necessitating skilful adjustment of those loose boards with his feet, after he had squeezed back through. But he managed the thing somehow, felt the

planking settle into place, and popped his head out again into the familiar dismal blackness of the hold. Then he drew a sadly battered doughnut from his pocket and began to munch it contentedly. After all, what more could a man desire?

And yet—of a sudden the idea came to him that the forehold was strangely quiet. When he had left it, those two over there somewhere had been snoring. He listened carefully, his jaws stopped halfway through a bite, and held his breath. Not an atom of sound broke the quiet. Could it be—?

Then with the unreasoning and absolute certainty of all sense-evidence mustered into one great impulse, came the knowledge of some human presence—right above him—in the dark. In one instant Sam Latham knew the depths of horror. An inarticulate cry rose in his throat—and there died.

For two sinewy hands closed beneath his jaw; and a lisping, husky voice hissed, "I got the feller! I got him!"

After the cry, silence fell again. In silence the whole black world swam and reeled, while that vise clamped on Sam's throat pressed home. For leaden minutes the boy writhed in the agony of his tortured, bursting lungs. The thing became unbearable, beyond all human endurance—

And then at length his body went limp. His last thought was of a vague regret—for something unaccomplished—he could hardly say just what. But it would not matter now. There probably was no need to worry over anything. The world was dropping away somewhere—smoothly—easily. It seemed pretty good just to sleep. Finley! Who's he?—Never mind—sleep—

THERE is no sweeter sight than the length and lift of a three-master beating sturdily to windward on her virgin cruise. She towers proudly into the sky and tilts a little, careening like a sea-gull set against the wind. The sun makes her new canvas shine like freshly fallen snow; it glistens on the varnish of her spars and rail, and brings out all the flat-white of her deck-house, bulwark, and coamings in sharp and vivid contrast with the emerald and turquoise just beyond. And every snap of taut sheet and halyard, every slightest creak and whine of stout and seasoned timber, sounds a challenge on the air. She is the nearest approach to perfection of which stumbling man is capable. No whole-souled human, seeing her riding there, can doubt that she knows it and exults



But Captain Henry Latham stood on the windward grade of his quarter-deck and regarded the world about him with a troubled eye. For all was by no means well with the *Etta Deering*. She had the fairest sort of weather—a steady southerly that spun her along at close to nine knots. Halfway Rock lay already on her starboard quarter; she would probably pick up Cape Ann sometime before night and possibly make harbor before noon of the next day. Yet—

"What did Cook say to that, Joe?" the captain asked.

The *Etta's* helmsman regarded a quiver in the luff of his towering mizzen-sail and set his wheel up half a spoke before replying.

"Cook, he says the feller lied. He 's set out plenty mug-ups for all hands twice over, he says, both nights since we cleared the river mouth. The other feller, that 's Ed Barrows, him that was on the mid-watch last night, he was plumb mad at not gettin' nothin' but slum when he come off at eight bells this morning. Plumb mad they both was, an' they 'd of started at it lick an' split had not ol' Brewer cracked a joke an' made 'em both look foolish."

The man paused and the skipper waited.

"Myself, I ain't no ways certain how or what or where the truth is. Cook ain't makin' it up—you and I both knows that. No more, likewise, is ol' Ed Barrows. Neither one of 'em 's anything but open an' honest as noonday.

"Well, sir, what 's the answer? Cook, he lays mug-ups a-plenty on the fo'c'sle shelf, an' Ed comes down four hours later an' finds the durn thing bare. What 's the answer?"

"Me, I calls it a mystery. 'Course, somebody 's took the grub. But who in blazes down there 's mean enough to snitch the hull durn outfit when he knows he kin get a barrellful of the stuff any ol' time, ef he wants, straight an' hot from the galley? Who is, Cap'n—you tell me!"

The skipper slowly shook his head. "You got me, Joe Smythe," he replied.

"An' myself likewise, Cap'n. But that don't help the mess none. They ain't no one in the bunch could of took that grub. *But some one has!* An' down below every man commences to suspicion the next one, an' look at him sideways when he ain't lookin'. Puts y' in mind of a pack of strange dogs all bunched together in the same room. Me, I calls it plumb uneasy. An' I begins t' see the *Etta* come short-handed mighty sudden an' mysterious, oncet she hits the dock.

"It 's a bad sign, a sign o' trouble. I seen a black cat crost the road 't ain't five minutes before I stepped aboard. I knowed then they 'd be trouble. Her fust trip, too—an' she such a trim piece!"

The old mariner's voice trailed off into dreary silence, and he turned again to the white expanse of canvas overhead, as if seeking there some panacea for his mental trouble. Latham had stood in silence, his arms crossed over his barrel of a chest, his feet braced against the *Etta's* buck and plunge, his white head, topped with its visored blue-felt cap, bowed deep in thought. But now he looked up quickly.

"I got it, Smythe," said he. "And I 'm a fool not to have thought of it before. It 's rats. They had a-plenty chance to come aboard whiles we lay to the dock taking ballast. They 're coming up through them loose floor-boards you fellers persuaded me to let the joiners lay in the fo'c'sle, and they 're causing the whole trouble. Rats—that 's the story!" said the skipper, with decision, and took to pacing along the weather rail as if to work off his excess relief.

"You might be right, sir," put in Smythe. "Me, I don't hardly think—"

"Right? Of course I 'm right! There is n't a thing else it could be, is there? There 's no reason why rats should n't have done it, is there? Of course it 's rats! And that 's the answer."

Smythe said no more. But his bleary eye, seeking again the luff of that snowy mizzen-sail, reflected no glint of assurance from the skipper's enthusiasm.

"It 's rats," repeated Henry Latham, to the world at large. "And when we tie alongside the dock I 'll get Waite's man with the sulphur candles. It 's rats," he told the shining binnacle. "We 'll smoke the varmints out."

SLOWLY, painfully, with infinite effort, Sam Latham drew a breath. He hated to do it; it was the very last thing in the world he wanted to do. He wanted to go on doing nothing—in the utter, restful darkness of oblivion. But through that darkness now for some little space of time a nameless longing had pricked him. He had shaken it off disgustedly, but it had always returned. "Draw in your breath," this foolish thing had whispered. "Draw in a breath and go on living." So at last, to be rid of the thing, Sam drew a breath. And it worked.

Not precisely smoothly. The boy's throat

felt crushed. When the air went by that place, in and out, it seared it like hot iron. But in his lungs the air was sweet and life-giving. And after a time his throat hurt less, or else returning strength enabled him better to endure it. He opened his eyes.

Still the forehold, that was sure. No crack of light pierced the heavy blackness on every side of him; and the damp new smell of sand and timber and the restless creak and groan and sway of a ship at sea—all these were the same as before. He lay, too, in his burrow; he could feel the sides of it encircling his body. But something was different.

He could not move. His hands were pinned closely at the wrists, his feet as closely at the ankles—both with stuff that felt like cloth. And a great wad of the same material, soft and evil-tasting, filled his mouth and was held in place there by a bandage which passed tightly over his lips and nose and was knotted behind his ears. He writhed a little, struggling to free himself. But it was no use; and swiftly, with full return to consciousness, black despair seized and held him.

Somewhere near he heard those two, his captors, whispering.

Again he heard the name of Finley. But the word meant nothing to his aching brain. Sheer mental agony dazed, befuddled him. And perhaps he might have slipped back into sweet unconsciousness, this time lasting, had not something happened.

There came, down there in that cavernous space, a gentle but insistent, grinding jar. Then, after a volley of stampings overhead, all sound and sense of motion ceased.

"She 's docked." It was the lisping voice. The sound went whispering back and forth across the empty hold. Deep silence fell, while three men waited for whatever was due—two of them in sleepy sullenness, the



"A THREE-MASTER BEATING STURDILY TO WINDWARD"

third one grown suddenly eager and breathless. For that loathsome, lisping voice had brought back the past into Sam's whipped, tottering brain. He remembered everything. And doggedly, with the iron will that was his father's, he began somehow to lay his plans.

A little shaft of vivid sunlight shot down into the forehold and lay smiling on the sand like a pool of gold. Sam heard vague voices



overhead, and saw in the now gray light around him two shadows slink like rats into the far and shadowy corners of the hold. Then footsteps rang sharply on the ladder-rungs.

Two men were coming down hand over hand. Sam craned his aching neck and saw their legs and backs. A cold sweat broke out on the boy's forehead, and out of the dusk his blue eyes gleamed a little wildly. The first man was his father.

They came down until they reached that pool of sunlight on the sand.

"Will two be enough?" asked Latham.

"Sure thing!" returned the other. "I got four here. We'll stick two in each hold."

Out of the corner of his eye Sam saw them stoop and fix two short, thick stakes securely in the sand. Then they struck matches and touched the flame to the upper end of each projecting stake, and with a weak blue sputter and hiss these things began to burn, sending up thin wreaths of clay-blue smoke into the still air. But the captain and his companion did not wait to watch or comment. As Sam looked again they were half-way up the ladder, glancing back hastily over their shoulders—to make sure the stakes were still alight, he thought. In another minute they were gone. And that little streak of sunlight was blotted out of existence. On the hatch cover, far above in the dark, men pounded. They were battened in.

To Sam, all this meant little. It had a vague, ugly look—that was all. He could see nothing really sinister in those two stubby things sticking into the sand, or in the thin blue smoke that circled weirdly over them. The battening of the hatch did not discourage him—he had his plan.

But out of the shadowy corners where those two had fled, there came a strangling cough that echoed and echoed in the ghostly haze. And after that a gasp, a choking cry that rose into a scream, hoarse and breaking with panic terror:

"It's dope sticks—sulphur dope sticks—poison—death—yah!"

Those two went clean amuck in the thin blue haze and silence, while Sam watched and listened and wondered. Like blinded, stupid brutes, they ran about in crazy circles, charging into bulkheads, stanchions, and each other, searching in the fog for those sputtering points of sickly blue, to stamp them out—and never reaching them. A grim sort of satisfaction swept the boy as he lay there, for his own eyes were well below the

level of the rising poison; his own lungs, guarded by the gag and bandage, did not feel its acrid sting and rasp.

And now the hunted wretches, mad with fright, had found the ladder and scrambled half-way up its length, and hung there in the still deadlier upper air, screaming, fighting one another in impotent fury, coughing terribly. Sam could not see them now. Something had begun to smart in his eyes, and he had shut them. But between the chattering screams, he listened for sounds from above that would mean rescue—listened a little fearfully, for a thin edge of acid was seeping through the cloth and seared his tender throat. But no sound came, and the boy remembered bitterly that all hands would go ashore.

Then the maunderings on the ladder died away in a pitiable gasping; and first one soft thud and then another told him those two had fallen senseless in the sand. The place became as still as death. And Sam Latham knew that if he was to go on living, if he was to save himself and reach Waite's office with his mission, it must be now, and swiftly, or it would be never.

He drew up his knees, dug his bound heels into the sand, and so pushed himself out of his burrow. He opened his eyes a tiny crack, saw in the ghostly fog a blue pin-point of sputter ten feet away, shut his eyes, and made for it—going always backward, raising his knees, pushing his body over the sand, wriggling, twisting, rolling. Finally he reached it, and, burying his face in the cool sand below it, raised his hands until the cloth between his wrists met the little flame.

An endless time he waited. A dry, hacking cough began to shake him; and when he lifted his head to peep at the flame, through half-closed lids, the candle and his two fists swam and circled dizzily. The cloth began to smolder, to scorch his hands and wrists, so that a new agony wrenched slowly at his nerves. But finally a loop of bandage fell apart—and with a snap and twist he tore his two arms free.

Sam clutched that stubby yellow cylinder before him; jerked it into the air; plunged its evilly sputtering end deep into the sand. Then he sat up and felt for the gyves about his feet. He found the knot, and with fast weakening fingers plucked it loose. His feet were free.

A strangely pleasant lassitude seemed to ease his cough and the bitter smarting of his eyes. He fought out of it, and went totter-

ing drunkenly on hands and knees across the forehold to his burrow. In he plunged, and wriggled madly through, sending the boards of the forecastle flying with a clatter.

Slumped there on the floor, he reached up feebly and snatched the bandage from his face, spat out of his mouth the soggy, noisome gag. Then for a blessed moment he lay back on the boards, drawing gusts of air into his starved throat and lungs.

new, fresh mask. Whereupon he went, head first, back into the burrow, crawled through it to the black cave beyond. He dared not open his eyes a crack, but stood up on his feet, his arms outstretched before him, and went feeling his way blindly across the sand. And by the grace of some protecting providence, his groping hand touched the ladder-rungs, and he felt a soft pile of something at his feet. Coughing tore him. Five



"SAM BEGAN HIS JOB"

But the end was not yet. Sunlight streamed through the open companion at the forward end of the forecastle; there at his side the black hole yawned. Two impulses tugged against each other in his brain. He wanted to follow both,—longed to with all his heart,—yet hesitated, fearing.

Swiftly came decision—singleness of purpose—a firm, unalterable resolution. As he got to his feet Sam smiled happily. It had occurred to him that he had seen his father make up his mind like that—swiftly, without looking back.

So he tore off a strip of gray blanket from the bunk beside him and fashioned quickly a

minutes longer in that place meant death.

Sam stooped; began his job.

Ten minutes later it was over. Two forms lay quiet, side by side, along the forecastle floor, their faces a horrible greenish blue—but breathing slowly. The boards were back in place. All the ports had been swung wide open. And Sam Latham—ragged, covered from head to foot with sand and sweat—was stumbling madly up the companion.

At the top he slammed the doors, slid the cover over, and slipped home the bolt. In another minute he was on the dock, a huge concrete affair to which he paid no slightest



heed. A watchman with a silver badge stopped and questioned him. But Sam ducked his arm and went plunging up the area, his soul laughing at the glorious sweetness of the air, the mellow sunlight.

A wondering policeman directed him toward the offices of the line in the Mutual. Luckily, it was not far. Sam had no eye for the towering buildings on either hand, no ear for the medley of sounds that clashed and honked around him. One thought dominated him. He lunged on desperately, fearing lest his trembling legs would refuse to carry him the distance. Somehow they managed it, and in a daze he found himself before a door marked "Private."

Without knock or introduction, with the hue and cry of an outraged office force hot behind him, he jerked open that hallowed door, slipped through and jammed it shut.

A small man, who he knew was Mr. Waite, was sitting at a great mahogany, glass-topped desk and looking across it at—the skipper of the *Etta Deering*. And as Sam opened the door he heard this small man say:

"Finley—dock superintendent—says—"

Then they turned and looked at the intruder. Sam's father gave a kind of smothered gasp, his eyes flashing sudden anger.

But the boy came steadily forward over the heavy green rug and stood by Waite and looked him squarely in the eye.

"If Finley's your superintendent, Mr. Waite, you better bounce him!"

The little man rose half out of the chair, his eyes fastened on the wretched figure standing there beside him. His lips formed themselves silently into a single questioning syllable. And swiftly, without preliminary or hesitation, Sam Latham told his story.

"You 'd better let him, Cap'n," Waite had said. "The way I see it, he 's bound to go, one way or another. And it will be some satisfaction to have him under your eye. If I were you, I'd jump at the chance. Come, come, Cap'n. You might as well give in. You can't stop a thing like this. It 's in the blood."

But so much had happened in the twenty minutes following his storming of the manager's office that when, at the end of that time, Sam found himself again on the street, it seemed years since he had left it to duck into the crowded doorway of the Mutual. And yet all sense of time was dulled by this great and wholly unexpected joy, which made him look around him at the crowds and cars and office-buildings—and giggle like a school-girl, for—

"It 's not hardly the thing," said Captain Henry Latham, taking the arm of his younger son and measuring steps with his, "it 's not hardly the thing for a master to be seen walking along shore with one of his own helmsmen. But we 'll go down the road a ways. I want to send a telegram. Just to let your mother know."

THE END

## UP BY STONY LONESOME

By ELEANORE MYERS JEWETT

Up by Stony Lonesome, close against the sky,  
There are long, lone meadows in the sun,  
And little scrubby cedars where the grass is sparse and dry,  
And winding, threaded paths the sheep have run.

Up by Stony Lonesome it is still, so still,  
For the hills hold peace upon their brows,  
And the cawing of a crow wakes the echo with a thrill,  
Or the faint *tonk, tonkle* of the cows.

Up by Stony Lonesome the road is overgrown,  
And dwindles into nothing by and by;  
And it 's there I walk enchanted, vision-wrapt and fairy-haunted,  
Up by Stony Lonesome and the sky.

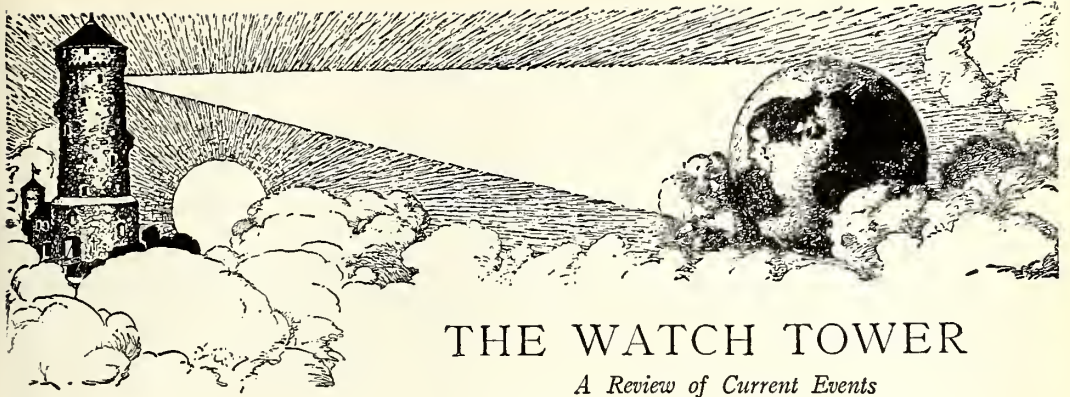

## THE WATCH TOWER

*A Review of Current Events*

By EDWARD N. TEALL

### BACK TO SCHOOL—HURRAH!

WE 'VE gone all the way round the sun again since last September, and it's time for another school year to begin—and for THE WATCH TOWER to say "Good luck!" to the army of boys and girls as they go back.

Just imagine what a sight it would be if all the school army had to pass a reviewing-stand on its way to work! Regiment after regiment would swing by, brigade after brigade, division after division. If they marched in ranks of one hundred, with files closed, it would take days for the entire enrollment to pass in review.

And *what* an army! An army not of death and destruction, but of hope and construction—an army of builders, building the America that is to be. Youngsters from the farms, the small towns, and the cities; some whose ancestors were early colonists, pioneers, and some whose parents were born in other lands; and all alike—we hope and trust—loyal to America, proud of her strength, her courage, and her love of justice, and all preparing to play their parts in her future.

Of the boys and girls who go back to school this month, some will stand later on one side, some on the other, of the various lines that divide us over questions of domestic and foreign policy. But the great thing for America is this: that the Army of Youth is all the time learning what it means for one to be an American, and acquiring the knowledge which, properly used, makes men and women strong and useful.

"Ten-shun! Forward—march!"

### TWO GREAT STRIKES

WE in America have made excellent progress in after-the-war readjustment. The only really effective obstacle to a revival of good

business conditions in this country was the one placed in our path by disagreements over wages. The railroad strike delayed the train of progress. The coal strike threatened to put out the factory fires and prevent production, to say nothing of the unpleasant likelihood that we should have to live in cold houses next winter.

Employers who would increase their own profits by giving their workers less than their service is worth are un-American, because they are not playing fair. Managers who can not make their businesses earn enough to pay the workers a good living wage are un-American, because they are not efficient.

Workmen who are not satisfied to take what their work is actually worth are un-American, because they seek special privileges. Workmen who try to prevent other men from taking the jobs they have given up are un-American, because they are interfering with other people's rights. They have the right to stop working if they wish to. Other men have an equal right to work wherever and whenever they wish to work.

In the time of slack production after the war, the business of transportation fell off. In order to draw more business and get the goods moving, lower rates were ordered. To enable the railroads to support themselves, the Labor Board ordered a cut in pay. War-time wages on the railroads were extremely high, and it was calculated that the new scale of pay would enable workers, at present prices of goods, to live as well as they had in 1915—and that means, better than they did a few years before that time.

But the railroad workers insisted that the cuts left them less than a living wage—and so they went on strike. Some of the railroads announced that after the strike the old



workers would be placed lower on the list than those who had taken their places; that is, they would have to begin all over again to make their record of length of service. There were threats; there was actual violence; and finally the President had to declare that the Government would, if necessary, run the roads itself. The railroads furnish an indispensable public service, vital to the nation's life; and no group of men can wreck that service.

Both the owners of the coal-mines and the union laborers in the mines had grievances. In their war, as in that of the railroad men, the prosperity of the country was threatened. And again, the Government had to consider the use of its power for protection of the national welfare. The President asked to have the mines run while the Government investigated conditions and acted as referee. Some of the operators were willing to accept the offer, some operators suggested a plan of their own, and the miners refused to arbitrate.

There is something wrong with the American people if difficulties, even so serious as these, can not be settled peacefully and fairly. There is always a possible arrangement fair

### WHAT ABOUT GERMANY?

THE assassination of Rathenau started people thinking harder than ever about Germany's future. Dr. Rathenau represented the best program for Germany's reconstruction—including reparation. He wanted to see Germany pay her bills and make good. Enemies of the republic killed him.

After his death Germany begged to be let off from part of her indemnity debt. She made her July payment, but declared she could not go on.

France presented the tart argument that Germany had spent a billion-plus dollars toward repairing war damages in France, while France herself had spent something like seven and one-half billions!

German guilt in the war can not be forgotten. Germany has been neither gracious nor graceful in her attitude toward war indemnities; if she had, it would be easier to give a favorable answer to her request for lightening of the load.

What can the other nations do? An extremely interesting offer was made by Great Britain: she would cancel France's war debt to her if France would cancel an equal



Wide World Photos

A REPUBLICAN DEMONSTRATION IN BERLIN, IN DENUNCIATION OF THE ASSASSINATION OF DR. RATHENAU

to all: to the employers, to the workers, to The People, represented by the Government. If we can't find and make that arrangement without destroying the prosperity that would surely be ours if we had no industrial wars—why, we are n't as sensible and efficient as Americans are supposed to be—that 's all!

amount from her own bill to Germany. This would give France an equal plus and minus in her accounts. It would relieve Germany, at England's expense.

Of course, England did not do this as a matter of charity. Undoubtedly, she expects to be repaid by her share in German trade.

Such an arrangement was bound to attract wide attention, for it seemed to offer a way to clear up the whole European tangle. It would help Germany to escape the menace of

Domingo and the restoration of native government. The plan had been approved by a number of Dominican men of influence, and Mr. Sumner Welles, of New York, was ap-



Keystone View Co.

A PANORAMIC VIEW FROM THE RIVER OF THE CITY OF SANTO DOMINGO

bolshevism, a danger to Europe more terrible than defeat by Germany in the war after the war—the fight for trade supremacy in the markets of the world.

#### PLAYING FAIR WITH SANTO DOMINGO

FIFTEEN years have passed since the United States undertook to control Santo Domingo's financial affairs, in order to make sure that the little nation's foreign debts would be paid. The treaty of 1907 confirmed an agreement made with the Dominicans in 1905, whereby the United States intervened to prevent the European powers from entering the island to collect by force what was owing to them.

We have traveled at a rate that makes 1907 seem now to belong with such "well and widely known" dates as 1066 and 1492. We might call it the year 7 B. W. Since then, while the war has been fought and the three first and hardest years of reconstruction passed, Uncle Sam has had a hand on the steering-wheel of the little island republic's ship of state.

Some critics of the Government's policy compare its action in establishing a military government in Santo Domingo with England's treatment of Egypt and Japan's of Korea (which *we* don't think are in the same class at all).

In June, the secretary of state announced that arrangements were being made for the withdrawal of American troops from Santo

pointed a Presidential commissioner with the rank of envoy extraordinary and minister plenipotentiary to go to Santo Domingo and learn what the island people would think of Mr. Hughes's plan.

In the summer of 1921, Admiral Robison, military governor of the republic, had announced that the American Government was ready to withdraw if it could be certain that orderly government would be kept up. There was some objection to the plan, and the evacuation was postponed.

This year, after conferences with a number of party leaders and officials of the republic, a new program was drawn up, calling for the appointment of a native provisional government to hold elections for a permanent government, and providing that the agreement of February 8, 1907, shall continue in force until Santo Domingo has paid the bond issues by which its debts were settled and the republic saved from bankruptcy.

The particularly interesting thing about this program is our Government's great carefulness in arranging to have the whole program rest on the will of the people of the island republic. The will of the majority was to be decisive, and the people were to be permitted to express their preference freely and fearlessly.

"Self-determination for small peoples" was one of President Wilson's ideals—and a good one. Perhaps some day, there will be so much common sense in this world and so much good will among men that the ideal will





Wide World Photos

THE FOUR COURTS BUILDING AFLAME DURING THE RECENT FIGHTING IN DUBLIN

become a reality. Meanwhile, we have to be thankful when large nations are willing to give the small ones fair play and use their power for friendly purposes, instead of selfish objects.

We believe the United States, with its Monroe Doctrine, is the right kind of a "big brother." Our relations with Santo Domingo promise to work out in a way that will support such a belief.

#### LETTER-CARRIERS OF THE AIR

THE record of the transcontinental air-service of the Post-office Department shows what progress has been achieved in making aviation useful in our daily life. In the year ended July 16, forty pilots flew 1,750,000 miles without a single life being lost. In the preceding year, seventeen pilots were killed while flying for Uncle Sam.

Nearly fifty million letters, weighing 1,224,500 pounds, were carried. The percentage of trips completed was 92.5, a substantial improvement over the preceding year's record of 83.

Division headquarters are at New York, Cleveland, Chicago, Omaha, Cheyenne, Salt Lake City, Reno, and San Francisco. Through mail, coast to coast, is put through in three days. The average speed is close to 100 miles an hour. At this exact rate, three days of twelve hours each would give 3600 miles. There are times when the planes, riding on a strong wind, do stretches as fast as three miles a minute.

There are other times when a mile in three

minutes would be thought a brilliant performance. Flying through a Rocky Mountain blizzard is no picnic—we have the fliers' own word for that! In all kinds of weather the planes cross mountains and deserts, and travel over forests and prairies.

No doubt there were some folks who thought the days of adventure were over when the transcontinental railroad was opened and the pony express went out of existence. And now the planes outspeed the trains by a day, and are beginning to run with almost the same regularity as they.

The next step will be to develop a system of guide lights, so that night flying will be possible.

The letter-carriers of the air are making a splendid record!

#### ANOTHER CHAPTER OF IRELAND'S STORMY HISTORY

DURING the summer there was civil war in Ireland. The Battle of the Four Courts was the beginning of a series of clashes between the National Army of the Free State and the irregular Republican forces.

Early successes of the Free State troops gave promise that the rebellion would fail.

We should certainly like to see Ireland independent and happy; and we can't see why, as a Free State in the British Empire, she should not be both. We regret that bitterness continues. We are sorry that the Republicans must be met with force.

But we believe also that the Free State—even with its great reservations of

power to the British Crown—is too great a forward step, once taken, as it has been, to be given up. And we hope it may speedily win a lasting peace among its own people.

### THE HAGUE—A “DUD”?

THE conference at The Hague, like the earlier one at Genoa, was a failure in one sense, a success in another. Neither meeting led to an agreement between the European Governments and that of Russia. Each meeting was concluded without new complications being created; each made clearer the nature of the great gap between civilization and the communistic “system.”

The Soviet Government, attacking capitalism,—the system of property rights,—wants capital. It is not willing either to pay Russia's old debts or to guarantee that new loans and investments would be protected so that those who furnished the money would be sure to get it back or to keep property they bought, like mills and factories. And the other Governments are, naturally, not willing to lend their people's money unless they know it will be safe.

So the conference at The Hague left us just where the conference at Genoa left us—except that our education in the weaknesses of communism was carried a bit farther, and it was made more clear that the rest of the world can afford to wait for Russia to come to her senses. She can not be comfortable and prosperous until she admits that two-and-two is four in Russia the same as in England or in America.

One positive good that has come out of these conferences is the fact that they have helped the European Governments to understand each other better and smooth off the rough surfaces of international policies.

### THROUGH THE WATCH TOWER'S TELESCOPE

TAKE a “squint” at Poland. She too has been passing through a crisis. She has been building up her industry and trade. Her troubles are mostly political. She has a presidential election coming on; and, with Russia and Germany for neighbors, her people are still nervous about foreign relations.

Mr. Paderewski, the great pianist, is talked of as a candidate for the presidency. Marshal Pilsudski is perhaps the strongest man in public affairs in Poland to-day.

IN mid-July the fiftieth anniversary of the creation of the Yellowstone Park Reserve, our first national park, was celebrated by the Wyoming folks. President Harding congratulated the nation on its possession of these



P. & A. Photos

GEN. SZEPTIEKA RECEIVING THE GREAT SWORD FOR CUTTING THE CHAINS AT THE FRONTIER BETWEEN POLAND AND UPPER SILESIA, SYMBOLIZING THE POLES' POSSESSION OF THIS TERRITORY

tracts of magnificent scenery, set aside for all time as the property of all the people.

THE Prime Minister and the Minister of Defense, of Canada, called on Secretary Hughes during the summer to discuss the possibility of a new agreement to take the place of the Rush-Bagot convention of 1817, limiting the naval strength of the two countries on the Great Lakes. The proposed agreement would also take care of the fisheries at the east and west ends of the long boundary-line. As far as we could make out, Secretary Hughes was entirely willing to have the Century of Peace repeated.



## NATURE AND SCIENCE FOR YOUNG FOLK

### THE CALIFORNIA ROAD-RUNNER

IF you have n't seen the California road-runner, you have missed some fun, for there is no bird more absurd and original in his looks and few more full of good-natured drolleries and amusing manners. He is built like a heron, except for his short legs, but, unlike that water-loving bird, chooses deserts for his home. He has wings, but scarcely has the power to fly; and though he does not look it, he is one of the fleetest of runners. When you look at this expressionless face, with its far-away look in the eye, you hardly can suspect him of being the comical jester he is, so full of sport and humor.

He is the one bird you never mistake for any other, with the bristle-tipped topknot which he raises and lowers at will, the reptilian-like face, with its deep-slit mouth, and the long tail, which so unmistakably registers his emotions.

The road-runner's speckled coat of feathers is a patchwork of varied colors. The feathers of the head and neck are dark steel-blue, those of the upper parts of the body are bronzy or coppery green, changing to purplish violet and green on the upper middle tail-feathers. The outer tail-feathers are steel-blue, with green and violet reflections. Everywhere, except toward the tail, the upper parts are streaked with white or brownish-white, especially the wings, this white-and-buff marking being produced by an odd, fringe-like fraying-out of the edges of the feathers. The peculiar bare space around the eye is beautifully marked with blue and orange. The only real somberness about him is the brown, tawny, and white that covers his breast, throat, and sides. Yet so intricate and wonderfully placed are the units in the mosaic of color, that the bird appears almost as brown or gray as the earth on which he runs. It is only when you are near him that you catch the iridescence and regal color-splendor of his coat.

This strange cousin of the cuckoo has earned his common name from his delight in sprinting along roadways, especially when pursued by horsemen or moderately slow-going vehicles. In the picturesque old days of California, it was no uncommon sight to see this bird, and his way of running a half-

mile or so in front of the fast-trotting horses was long remembered.

Another common name, chaparral-cock, is given in allusion to his living in the chaparral, of the semi-deserts.

The bird belongs wholly to the West. Formerly, he ranged from the plains of Kansas to the chaparral-covered hills of the Pacific Coast and from central California to Mexico, but he is rapidly becoming rare. Thanks to recent wise legislation, he has now been placed on the protected list of valuable, insect-destroying birds.

The road-runner makes no regular migrations, and you seldom see him except when he is alone. Only twice have I seen him with his mate. A sort of Bedouin is he, a thorough son of the desert, roaming free as the winds of heaven and impatient of the restraints of communal life. Nevertheless, the accusation of being a vagabond, like the shiftless coyote, can never be brought against him, for once he chooses his "stamping-ground," he seldom leaves it, preferring to stay year after year in the same vicinity.

Like a policeman, the road-runner apparently has his beats, and any one who watches him day after day will be surprised to note how regular and punctual he is in passing certain points at definite times. For two different winter seasons, attendance at college necessitated my passing along a hillside road every morning at seven o'clock. As regularly as I came, a certain road-runner was there on the road, roaming around, ready to let me chase him to the top of the hill, where, turning short, he would dash into the brush, to be seen no more until the following morning. I have always thought he did this in mere sport. An invalid on the Colorado desert called my attention to the fact that a road-runner passed her porch at 12:25 o'clock every day for over a week, never varying by more than a minute or two.

When on these daily feeding-excursions, the road-runner keeps close to the ground, running along at a silly gait and every few minutes stopping abruptly, as though a sudden idea had struck him, so as to make his tail grotesquely flop forward over his back. And then he gazes stare-eyed at you, as if he were in deep contemplation, his tail in the

meanwhile moving delicately up and down like the balance-arm of a scale.

This combination of magpie and cuckoo is a good sportsman, and at Annandale Golf Club, near Pasadena, so members of the club tell me, he is often seen chasing the golf-balls. His inquisitive and jocular nature also induces him at times to run after the ends of surveyor's chains as they are dragged over the ground by the chainmen. He will peck at the end of the chain, pick it up, and then drop it again with a look of surprise, as much as to say, "What an astonishing creature this is—nothing but shining bones!"

Persons who have tried to make a pet of



Courtesy of Museum of History, Science, and Art

THE CALIFORNIA ROAD-RUNNER

the "pasiano," as the Mexicans like to call this lanky, ludicrous, feathered wit, find him so mischievous that he often proves himself a source of endless annoyance. A Mr. Dresser of Matamoros, referred to by Dr. Ridgeway, who had one partially domesticated, found he could not let it remain in the house at all. "It would hide and steal everything it could carry off, and was particularly fond of tearing up letters and upsetting the inkstand. It was never caged or tied up, and would frequently pay the neighbors a visit, always returning before evening. The bird had a singular antipathy to a tame parrot, and whenever the latter was let out of the cage it would get into a rage and either go to the house-top or decamp to the neighbors."

In spite of his prankish, sportive nature, the Mexicans look upon the road-runner as a purveyor of good luck and a very desirable neighbor, and he is not unwelcome when he comes, as he often does after getting acquainted, to share a bit of grain with the barn-yard fowls.

The pasiano's appetite is as queer as his looks. He eats everything you would not

expect a bird to eat. With avidity he devours horned toads, crabs, grasshoppers, mice, centipedes, and even snakes, and cactus fruits he will not despise. Lizards, however, are his chief diet, and these he cleverly picks off the rocks, one stroke of his bill being sufficient to kill them. Where snails are abundant, he eats greedily of them, and naturalists tell of his habit of always carrying the snails to a particular spot before breaking open the shells and eating their juicy contents. Broken shells collected in small heaps in places frequented by road-runners are often found.

Late in May I saw a funny sight when, with a whirl of wings, a road-runner sprang down upon an ill-starred lizard and almost literally pinned him to the sand as he struck him with his bill. Though he had caught his game, to carry it away was not so easy, for, like all good lizards, it had disjoined, or at least lost, its tail in the onset. Quickly the road-runner picked up his prey—so much done. But he was now at a loss to know how, when his jaws were already pried wide apart by the reptile's body, he could pick up the wriggling, squirming tail. He looked at it, puzzled, and tried again and again to take it up without putting down the lizard. He seemed to be suspicious that the latter might then run away. So repeatedly the mandibles were pressed together until the lizard's bones were well cracked; then the obstreperous tail was picked up, and the bird, his head high in the air, hurried off to its young.

It is not every day that you run across the nest of this curious dweller of the desert, and I was filled with emotion when, by a rare chance, I found the mother sitting on a pile of the sticks, which formed the ill-made nest, placed some seven feet above ground in a juniper shrub. With her mottled and speckled plumage, she was so very inconspicuous that I should not have seen her had she not jumped off the nest as I approached.

What interested me, as the days went by, was not so much the rude home, lined with everything from a snake-skin to bits of refuse, or the four yellowish eggs within it, but the patient mother, who sat almost seven weeks on the nest, first with the eggs and then with the young. This was due to her strange manner of hatching the eggs. As though she dreaded caring at one time for a whole brood of awkward, gawky, gluttonous, clamoring youngsters of the same age, the eggs were laid at considerable intervals.



Thus the first of the brood were ready to leave the nest when the last ungainly birdlings were breaking from the shell.

How many insects, centipedes, and lizards disappeared down the throats of those lusty youngsters is hard even to imagine, they were always dreadfully hungry and were often fed.

There are many versions of the story which points out the chaparral-cock as a killer of rattlesnakes, but in them all there is the rattlesnake who is caught asleep and surrounded by a circlet of cactus-pads by a clever road-runner. The snake wakes up, and, realizing his plight, bites himself and dies. When you ask the narrator if he witnessed the incident himself, he always says he knows it is true, but ends up with, "Somebody else told me."

A reliable observer, whom I questioned very carefully, tells me an incident which seems more probable.

"While out rabbit-hunting, my attention," said the young man, "was drawn by the queer actions of a road-runner. He was repeatedly seen flying with something in his mouth, which, on close scrutiny, proved to be joints from the deer-horn cactus, a slender, much-branching species of the foothills. These he would drop in the trail ahead, and then would alight and engage in such queer antics as jumping up in the air two or three feet, flapping his wings, and screaming. Again and again he went through the same performance. As I came nearer, I witnessed a pallid, or yellow, rattler some three feet long, writhing in pain in a mat of cactus-joints, their needles in many places thrust through the body. For many feet these spiny joints were strewn through the brush, showing that the bird must have worked some time at his task of dropping the prickly pads on the snake, who was trying to crawl away from the nest he had been seeking to rob. The reptile was almost dead with exhaustion and wounds as I left him to his fate, and the road-runner was standing by, watching his cruel fun."

I have interviewed several desert travelers who tell of finding snake bones beneath piles of cactus-joints and of being unable to account for it. Perhaps the above incident will help to explain it.

There are three things in which the road-runner's poverty is great—his sense of smell, his power of flight, his power of song. The sense of smell in all birds is slight. Even vultures must depend on their sense of sight

for the detection of carrion, and in no degree on their sense of smell, as might be thought.

The road-runner, who relies on his trusty legs for making off when pressed by an enemy, has little use of his wings. He realizes what poor makeshifts of organs they are for sustained flight, and, like the ostrich, uses them only as aids in running or jumping. As he flees at top speed, however, he spreads his wings and finds them invaluable in maintaining poise.

The pasiano has no song, his only utterances being a loud forcible coo and strange whistling note (ōō—t) ending in a louder clattering, chipping noise, made by rapidly bringing his mandibles together. The whistle sounds as though it were produced when the breath was being drawn in—a sort of pumping noise.

When the road-runner looks at you, he always gazes steadily with one eye, his head being turned sidewise to you. Thus he gets the best possible view. The curious thing is that at the same time he is examining your appearance, he, with his other eye, may be scrutinizing and recording the image of another object. Thus he watches two fields of possible interest at the same time. He is, in other words, doubly watchful and doubly secure. Again, if he wills it, he can suppress the vision of one eye, ignore its sensations, and focus his entire attention on an object before the other eye. He makes himself blind in one eye at will for the purpose of attending better to the vision of the other. On the whole, the vision of birds is a hundred times more acute than man's, especially with respect to moving objects. They see a thousand things that our blind eyes never register.

EDMUND C. JAEGER.

#### 5 A WIND-TUNNEL FOR TESTING TINY PLANES

AS the fast passenger-train speeds you across a steel suspension-bridge, the thought may come to you, "How wonderful that these trusses bear this heavy traffic and never give way!" Naturally, you feel proud of the twentieth century and of the bridge, one of its great engineering feats.

Possibly you have not come to feel the same way about an airplane. Yet the processes by which aircraft are built have reached a fineness paralleled in no other vehicle and in few pieces of machinery.

At one of the big airplane plants at Garden City, Long Island, there is much equipment of this high scientific quality—for instance,

three wind-tunnels and the wind-tunnel model-shop.

A wind-tunnel is a device by which the scientist can show how an aëroplane will fly, without going to the trouble of flying or of telling it.

Imagine a huge tube 70 feet in length and also 17 to 17 feet in diameter, suspended by end-wires in a great room. At one end, on a platform, is a 400-horse-power motor with a specially designed propeller, which sucks the air through the tunnel at speeds which may approach 100 miles per hour.

You can go into this tunnel and see how it works. You enter the experimental chamber, the lower story of which is below the huge tube; then you climb a short pair of stairs and are in the tunnel itself.

Presently, there enters a member of the research staff with what looks like a toy—a beautiful aëroplane scarcely a foot and a half in wing-spread, with mahogany body and aluminum wings. He, too, mounts the stairs and gravely sets the plane on a steel pedestal projecting up into the tunnel from the lower floor of the experimental chamber.

"Just a balance," the scientist explains with regard to the affair; "weighs like the grocery-store scales, only much better; weighs wind-pressures instead of potatoes, and reads to one ten-thousandth of a pound."

He touches a lever and turns on the wind. There is a hum and a rush, but you feel nothing. "Put out your hand," says the scientist, his lips close to your ear.

The hand comes back as if parried by a giant. The experimental chamber is a dozen feet across—the rest of the tunnel seven. The air is passing so rapidly, however, that it comes through the chamber in a column instead of spreading out, and you can stand outside this core of wind and feel no rush of air at all, though, a foot away, the atmosphere is going as fast as a swift plane with a 20-mile wind on its tail.

All this may seem a bit childish. What can a toy, a balance, and a bit of wind do to make aëroplanes safe?

Everything. Science has gone far, far beyond *Darius Green*. It has not only proved that you can learn to fly *from* a barn, but *in* a barn. The miniature aëroplane is a model constructed to the scale of engineering plans for the contemplated machine. It is accurate in shape to the thousandth of an inch. The tunnel is also accurate. It has been built after a study of all important existing wind-tunnels, and is believed to be the largest

in the world. By means of model, air-flow, and balance, engineers can figure mathematically what will happen in the air when the full-sized aëroplane flies. The large planes have the same shape as the small models. Those in charge of the work can read the air-pressures on any part of the model, and the rushing of the air past the miniature plane is

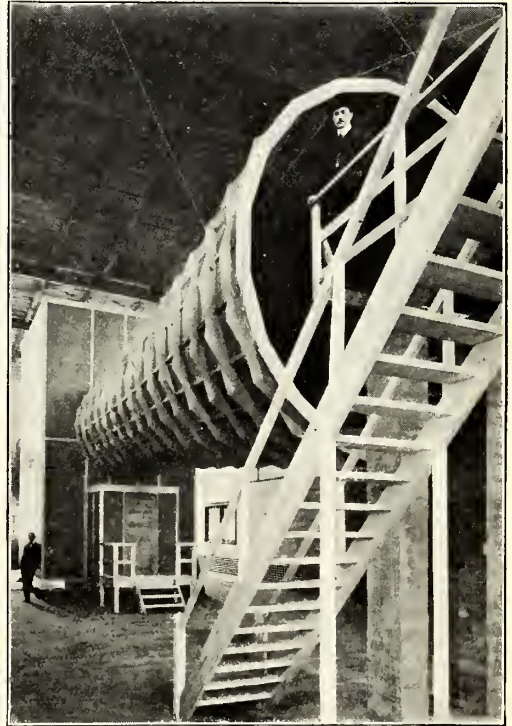

THE WIND-TUNNEL, 70 FEET IN LENGTH

equivalent, for all working purposes, to the rushing of an actual plane against the air.

The result is that the "trial flight" of one of the actual machines, produced after such exhaustive tests, is no longer an experiment. What the aëroplane can do can be prophesied exactly. The wind-tunnel has, to date, made 100 per cent. correct predictions as to the general behavior of these machines.

The wind-tunnel not only checks up on designs, but furnishes material for them as well. Shapes of struts, wind-driven air-pumps, problems in stability, head-resistance, lifting efficiency of wing surfaces, etc.—all are material for wind-tunnel work.

Thus science is working steadily to determine with perfect accuracy certain principles that have the greatest value in assuring the safety of the daring men who skim lightly through the air.

GEORGE F. PAUL.



## FOR VERY LITTLE FOLK



"HE LOOKED INTO THE MISCHIEVOUS BROWN EYES OF A DWARF"

### TOM-TOT AND THE DWARF

By EDNA GROFF DEIHL

BOY and Rover sat by the wood-fire, glancing intently into it. Boy had just whistled a long, low whistle. A whole host of tiny fairies suddenly stood balancing themselves the length of the sparkling log.

"Be quick!" said a twinkling one to another, who stood in front of the rest. "We must be off to the ball! Obey his summons by telling him the story of Tom-tot!"

Once upon a time, then the Fairy of the Raven Locks began, there was a little fellow named Tom-tot. Every one loved him dearly, but his grandfather, with whom he lived, loved him best of all.

Now his grandfather was very old and very deaf, and one day when Tom-tot said to him, "May I go into the green, dark woods behind the town, Grandfather?" his grandfather thought that he said, "Shall I go out and bring in some big hard wood and lay it down, Grandfather?" So he nodded his head "Yes," because he wanted to make a fire on the hearth, as it was growing colder.

Tom-tot went out into the big, dark, green woods behind the town, and lay down in the cool green grass. Pretty soon he heard the tiniest step behind him, coming out from

some deep bushes, and he looked around into the mischievous brown eyes of a dwarf, all wrinkled and curved and tanned. As his eyes met those of the dwarf, the wrinkled fellow said in a faint, quivery voice, all choked up with fun:

"Tom-tot, Tom-tot,  
You shall be what you are not;  
And you shan't be what you are  
Till shines out the evening star."  
And then, before Tom-tot could turn, he



"THE RABBIT KICKED UP HIS HEELS AND RAN AWAY"

found he'd become a woolly, brown bear!

Tom-tot ran hither and thither through the dark green woods, scarce knowing what to do. Pretty soon he met with a rabbit.

"Ugh!" said the rabbit, "where did you come from? There has not been a big brown bear in the cool green woods these many years? Who are you?"

And Tom-tot answered:

"I was Tom-tot;  
Now I am what I am not;  
And I have to travel far  
Till shines out the evening star!"

Then the little rabbit winked his ears and kicked up his heels and ran away to tell the other little creatures of the dark green wood all about the big brown bear.

Tom-tot wandered on until he met with a squirrel. The squirrel straightened out his bushy tail and ran quickly up a big oak, calling down, "Where did you come from, big brown bear? There has not been a big brown bear in the cool green woods these many years. Who are you?"

And Tom-tot answered:

"I was Tom-tot;  
Now I am what I am not;  
And things won't be regular  
Till shines out the evening star!"

Then the little squirrel ran higher into the branches of the cool green tree and chattered madly away to the birds all about the big brown bear!



"WHERE DID YOU COME FROM, BIG BROWN BEAR?"

Tom-tot wandered on and on in his bearskin until he came to a clearing. It was growing dusk and he sat down on a log to rest. By and by a little boy carrying a pail of water came along. When he saw the big brown bear he was most terribly frightened. He dropped the pail of water, and started to

run, calling out in his fright: "Where did you come from, big brown bear? There has not been a big brown bear in the cool green woods these many years? Who are you?"

And Tom-tot answered:

"I was Tom-tot;  
Now I am what I am not;  
And I shan't be what *you* are  
Till shines out the evening star."



"HE WAS MOST TERRIBLY FRIGHTENED"

The little boy started to run harder than ever. But just at that moment over the hills shone the evening star, and when the boy looked around, expecting to see a bear chasing him, a little boy called to him: "Don't be afraid. Now I am what I was. I'm Tom-tot,—just a little boy like you,—and we can both walk back to the village together."

When Tom-tot reached home his grandfather looked up at him and said, "Tom-tot, you are late. Light the wood logs you brought in to me."

Tom-tot looked around, wondering what his grandfather could mean. There in the corner was the very nicest pile of kindling, and on the very top log stood the mischievous dwarf, all wrinkly and curved, with a merry twinkle in his brown eyes, who said, "I brought the wood in for you, Tom-tot, while you were what you were not."

And with that he disappeared behind the pile of logs.



"ON THE VERY TOP LOG STOOD THE DWARF"



# ST. NICHOLAS LEAGUE

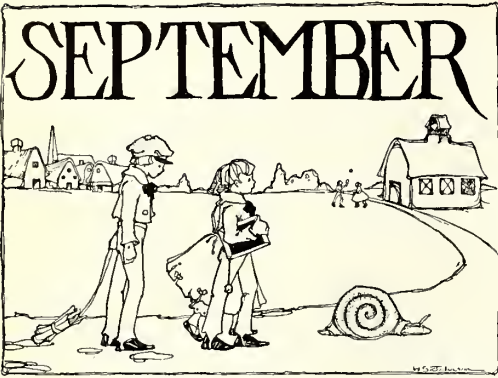

"A HEADING FOR SEPTEMBER." BY HELEN SEWELL JOHNSON, AGE 15. (HONOR MEMBER)

SCHOOL-DAYS draw near at a rapid rate, and before long the great army of LEAGUE boys and girls will be on its way to class-rooms—some of them, perhaps, after the fashion and at the pace of the children and the snail in the drawing on this page. Vacation days will soon be pleasant memories, recorded in many cases, no doubt, by photographs; a number of these cheerful holiday spots are shown in this September LEAGUE, and more of them will probably appear in later competitions.

To LEAGUE members, the thought of books and recitations should not be dismaying, for they are

so accustomed to doing things and doing them well. Take the subjects for each issue of the LEAGUE, for example. One might consider them on a par with assignments at school—they certainly call forth as much effort, and perhaps a greater degree of originality, and yet we are amazed to see, by the first of each month, the flood of contributions that have poured in.

We are happy that the LEAGUE means so much to our boys and girls; that they work and work for it, and richly earn the rewards it has to offer—rewards not measured entirely by gold and silver badges and honorable mention, but by the training so acquired in the art of expressing one's self, and in general culture and high ideals.

The contributions which appear on these eight pages this month are very much like the ones on the same pages last month, and the month before that, and so on back to January 1900, when THE LEAGUE first appeared—they are excellent! It is difficult to scatter praise fairly when each and every item is worthy of the whole of it. Under that interesting title, "A Test of Friendship," we find old stories retold and new ones ingeniously contrived. There is verse that sings itself and lures one "over the hills and far away," while the photographs beckon to the out-of-doors. Our artists show their usual skill and aptness in drawings of the subject "Going Away."

Truly, it is a good LEAGUE. Soon we shall have to coin a slogan, such as advertising men are always doing, and say, "When better things are done, LEAGUE members will do them!"

## PRIZE COMPETITION No. 270

(In making awards contributors' ages are considered)

**PROSE.** Gold Badge, **Emily Lee Brandt** (age 12), New York. Silver Badges, **A. Edith Osgood** (age 12), Massachusetts; **Margaret B. Walton** (age 14), Pennsylvania.

**VERSE.** Gold Badges, **Susan Clayton** (age 16), Georgia; **Donald Fay Robinson** (age 17), Massachusetts. Silver Badges, **Marion Thompson** (age 13), New Jersey; **Ruth Munson** (age 16), Michigan; **Carolyn Allen Davidson** (age 10), Texas.

**DRAWINGS.** Gold Badge, **Phyllis Reeve** (age 15), New York. Silver Badges, **Julia A. Pratt** (age 12), New York; **Patricia Seaver Thomas** (age 12), California; **Teresa de Arteaga** (age 12), Spain; **Lillian Aspell** (age 16), New York.

**PHOTOGRAPHS.** Gold Badge, **L. O. Field** (age 16), Wisconsin. Silver Badges, **Margaret Fegtly** (age 17), Arizona; **Lucretia C. Ramsay** (age 16), New York; **Robert K. Chisholm** (age 15), New York; **Bertha Schmidt** (age 13), Minnesota; **Anna Lange** (age 16), Honolulu; **Mary K. Folwell** (age 14), Pennsylvania.

**PUZZLE-MAKING.** Silver Badge, **Gertrude R. Jasper** (age 14), New York.



BY MARGARET C. BULLOCK, AGE 16



BY VIRGINIA MILEY, AGE 14

"MY MOST ARTISTIC PHOTOGRAPH"

## "OVER THE HILLS"

BY SUSAN CLAYTON (AGE 16)

*(Gold Badge. Silver Badge won May, 1922)*

IN the dim, eternal silence of the hour  
 Before the torch of heaven is held aloft,  
 While the gray gloom threatens  
 To circle round and crush out all the starlight,  
 I wonder what lies over there  
 Beneath the quivering star of love,  
 As it prepares to dive into the high-tossed waves  
 Of pines outlined in black against the sky  
 Over the hills.

The flush of morning floods the gloomy gray,  
 And the stars are drowned in overpowering glory;  
 But still I think of what must be  
 Over the hills.

A voice, in many tongues, calls,  
 Calls to me in accents bewitching,  
 Luring me to dream, till the heavenly gold has  
 fired the earth,  
 And with its last burnished flame ignites the  
 farthest hill.

That is the flame that burns my heart,  
 That sets the smoldering fires of high desire  
 To leap out into the great unknown  
 Over the hills.

Who knows but what life, love, pulsating liberty,  
 the everlasting,  
 Lie where the star of love falls, and the nameless  
 voice calls  
 Over the hills?



"GOING AWAY." BY PATRICIA SEEVER THOMAS, AGE 12  
 (SILVER BADGE)

## A TEST OF FRIENDSHIP

BY EMILY LEE BRANDT (AGE 12)

*(Gold Badge. Silver Badge won May, 1922)*

WILL and Horace were friends. Their fathers' plantations were adjoining, and the boys had been inseparable companions from childhood.

Then the Revolutionary War began. Will joined the Continentals, but, alas! Horace joined the British. After hot words, the two young Virginians parted.

Years passed by. Finally, one day during the siege of Yorktown, a prisoner was ushered into the presence of Sir Horace Carrington. "This is a spy. Here is the proof," said the guard, laying some papers before Sir Horace.

Sir Horace, having dismissed the guard, turned to the captive. "Will!" he gasped. "Horace!" was the reply, as they rushed to embrace each other.

"Are you a spy?" asked the Tory.

"Yes."

Horace turned pale, and, sinking into a chair,



"GOING AWAY." BY PHYLLIS REEVE, AGE 15. (GOLD BADGE  
 SILVER BADGE WON JULY, 1922)

remained for some moments in an attitude of despair. At last he arose, tore up the proofs, and threw them into the fire, exclaiming, as he turned toward Will, "You shall have a pass to your lines."

A rustle, and both men looked up. In the doorway stood Lord Cornwallis. Without hesitation, Sir Horace boldly said: "My lord, I wish to ask you to give my captive friend a pass to his own lines. It would be a great kindness to me."

Cornwallis was devoted to Sir Horace. With a care-worn countenance, his lordship gazed from Horace to Will. Finally, with an unpleasantly knowing smile that made the culprits tremble, he said, "Certainly I will." Seating himself at a table, he began to write. In a moment he held out the pass to Will, and the two friends, with profuse thanks, departed.

"Truly," exclaimed Cornwallis, "that was a double test of friendship!"

## A TEST OF FRIENDSHIP

BY MARGARET B. WALTON (AGE 14)

*(Silver Badge)*

"MAY! May! Oh, wait a minute!"

May Elliot stopped as she heard the call, and, turning around, waited smilingly for her friend to catch up. The girl who had sent her voice echoing down the long hall of the boarding-school now appeared. She was fair of complexion, with beautiful curly hair, and the kind of a mouth that just won't curve any way except up at the corners. Now she was panting for breath, her curls were flying around her face in beautiful disorder, and there was a roguish light in her eyes. Yes, Corinne Dexter was beautiful, and popular too—there could be no doubt of that.

"Whatever is the matter, Corrie? To hear you call, one might think that Lancaster Chapel had burned down over night!"

"Oh, May," came the swift answer, for Corinne had got her breath now, "I just could n't get my Latin, and I want you to lend me your paper. I know you've got it—you always have. Please let me take it, Maysie, if you want to save my life."



May stood stock-still in the hall. It had often occurred to her lately that Corinne was growing careless about her lessons. She was more and more apt to borrow some one's paper and copy it at the last minute. May loved Corinne, despite her carelessness, as, in fact, did all the girls.

"Corrie, I can't let you have it. Don't you see what a habit you're forming?"

Impulsive Corinne turned swiftly away. "I thought you were a friend of mine!" she cried angrily, and then disappeared.

As a matter of fact, May was a true friend. The test of real friendship was a hard one, but she passed it successfully. In after years, Corinne often thanked May for helping her to break her bad habit by meeting the test of friendship.

### OVER THE HILLS

BY DONALD FAY ROBINSON (AGE 17)

(Gold Badge. Silver Badge won November, 1919)

"WHAT lies over the knoll, Mother,  
Back of the cow-shed door?"  
"The next-door neighbor's farm, dear,  
And Whiting's grocery store."

"And what lies over the hill, Mother,  
Back of the neighbor's barn?"  
"Over the hill is the village square  
Where Grandmother gets her yarn."

"And what lies back of the mountains,  
Over the village square?"  
"Back of the mountains? That, dear,  
That is the world out there."

### A TEST OF FRIENDSHIP

(An Old Story Retold)

BY PHYLLIS DALE (AGE 13)

WHEN a king named John ruled England, there lived an abbot in Canterbury who every day had a hundred noblemen dine with him and fifty knights wait upon him.

King John heard about this, and so he ordered that the abbot should be brought to him.

"Unless you can answer me three questions," said the king, "your head shall be cut off, and all your riches will be mine."

The abbot begged that he give him at least two weeks to think, and this the king did.

On his way home, the abbot saw his shepherd going into the fields. He called to him and asked him if he could not help him. The shepherd said yes, everybody thought that he and the abbot looked alike, and that he would go up to London and see the king.

When he arrived at the palace the king greeted him and thought he was the abbot.

"My first question," said the king, "is how long shall I live?"

"You shall live until the day that you die, and not a day longer. And you shall die when you take your last breath, and not one moment before," said the shepherd.

The king laughed and said, "You are very witty. Let that pass. Now tell me how soon I may ride around the world."

"You must rise with the sun; and you must ride with the sun until it rises again the next morning. As soon as you have done that, you will find

that you have ridden around the world in twenty-four hours," said the shepherd.

"Now what do I think?" said the king.

"You think that I am the abbot of Canterbury. But, I am only his poor shepherd, and I have come to beg pardon for him and for me."

"And you have won pardon," laughed the king.

### A TEST OF FRIENDSHIP

(A True Story)

BY VIRGINIA KLEIN (AGE 11)

WE live in the country and have ponies, ducks, cats, and quite a few other animals. One day last summer we went down to see the pony, and in her manger, that she ate out of all the time, was the nest of one of our Japanese ducks, and close beside it was a mother cat and her kittens. In a very few days the little fluffy ducks had hatched, and there too was the mother cat and her darling little wee kittens.

Whenever the mother cat would go to get some milk, or go for a walk, the mother duck would sit and cluck and be just as motherly and good to the kittens as to the ducklings. She would always wait until the mother cat had come back before she would go, so that one mother would be there to look after the babies.

The mother cat would be just as kind to the ducklings as to her own children, and would lie down with the babies and go to sleep and rest until the duck would come back.

If the little ducks had been able to get out of the manger more easily, they surely would have gone swimming in the lake the day they were hatched, for some of our ducks have done this. But they had to grow larger, so that they could get out of the deep manger.

The pony continued to eat from the manger, and did n't seem to frighten the baby kittens or ducklings in the least, and they all grew up to be great friends.

### OVER THE HILLS

BY MARION THOMPSON (AGE 13)

(Silver Badge)

OVER the hills on my dashing steed,  
Over the hills so wide;  
Over the hills so green and gay  
On my pony Prince I ride.

Over the hills that once were green,  
But now are brown and gold,  
Over the hills I ride again  
As I used to ride of old.

Over the hills now white with snow  
My Prince and I do fly.  
The air is cold; the snow is deep;  
The wind is rushing by.

Over the hills we dash once more;  
A bit of green I spy;  
The wide world holds no queen to-day  
Who's happier than I!

Over the hills I love to dash  
And fly with lightning speed,  
At any season of the year,  
On Prince, my faithful steed.



BY BERTHA SCHMIDT, AGE 13  
(SILVER BADGE)



BY HELEN ROSENHEIM, AGE 11



BY ANNA LANGE, AGE 16  
(SILVER BADGE)

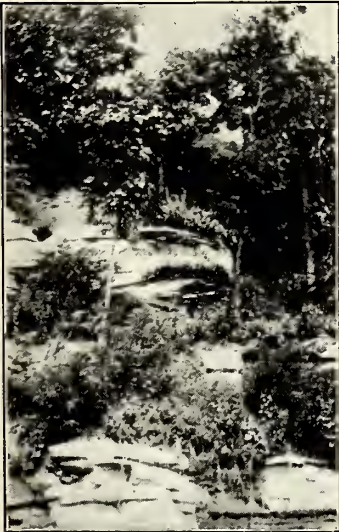

BY FRANCES KAUFFMAN, AGE 13



BY MARY K. FOLWELL, AGE 14  
(SILVER BADGE)



BY FRANCES HULLIHEN, AGE 11



BY MARGARET FEGTLY, AGE 17. (SILVER BADGE)



BY RICE S. ESTES, AGE 15

"MY MOST ARTISTIC PHOTOGRAPH"



## OVER THE HILLS

BY CAROLYN ALLEN DAVIDSON (AGE 10)

*(Silver Badge)*

OVER the hills and far away  
Is a land where the children are wont to play  
With the fairy folk from near and far,  
Whose queen is the child of the evening star.

They laugh and play 'neath the rosy sky,  
Till the dream ship comes, when away they fly  
To the Castle of Dreams, where they behold  
The wonderful visions of childhood unfold.

And all the night the little ones stray,  
Till over the hills, at peep of day,  
They come dancing and tripping, each hand in  
hand  
With a wee little sprite of the fairy band.



BY LILLIAN ASPELL, AGE 16  
(SILVER BADGE)



BY JULIA A. PRATT, AGE 12  
(SILVER BADGE)



BY MARY ELIZABETH JONAS, AGE 12

"GOING AWAY"

## A TEST OF FRIENDSHIP

BY A. EDITH OSGOOD (AGE 12)

*(Silver Badge)*

JERRY and Lad had always been friends, ever since Lad was a rollicking, furry puppy. And now he was a big gold-and-white collie, with a white, gold-tipped plume of a tail. Jerry was ten, and a small boy for his age. On account of his health, he had never been allowed to participate in the other boys' sports.

One warm afternoon, while Jerry and Lad were taking their usual walk through the woods, they passed the swimming-pond. The cool, quiet water looked so inviting that Jerry could not resist the temptation to wade in a short distance. Taking off his shoes and stockings, and rolling up his trousers, he told Lad to stay on the bank. Wistfully, the dog watched his master paddling joyously in the water.

And then, without a moment's warning, the

play turned to reality, for the treacherous stones slipped, and Jerry fell into the dark water, taking a large gulp of it into his lungs. Simultaneously, a gold-and-white streak flashed from the bank, and in five seconds had the boy by the coat. It was with much difficulty that Lad managed to tow the unconscious Jerry to the shore, but after desperate efforts, perseverance conquered. Then, tired and panting though he was, he ran as he had never run before to the house, and, with his urgent barking, quickly summoned aid.

Soon Jerry opened his eyes, and between the questions of his anxious parents, told the whole story. Lad had taken his test and passed with honors, and in that instant, while the dog looked at the boy with adoring eyes, and Jerry stretched out his hand to lay it on the tawny head, one more link was added to the strong bond of friendship between them.

## OVER THE HILLS

BY MARGARET G. TROTTER (AGE 14)

*(Honor Member)*

AT twilight, when the clear light slowly fades  
And frogs are piping in a pond, I look  
Across the valley to the dappled hills.  
Beyond, I can not see, nor have I been;  
They mark the boundaries of my world to me,  
And, after days of toil, I sit and look,  
Deaf to the sounds about me, and I rove  
In fancy far beyond encircling hills.  
A loon's cry throbs above the hushed night,  
Sad, desolate; I am recalled again  
From those far lands where I have never been.  
Again, they are obscured by high-piled clouds,  
While lightning flashes luridly illumine  
Their sides. I shiver, thinking now that I  
Were better sheltered in my peaceful home,  
Unbuffeted by those fierce storms which rage  
About the teeming world, beyond the hills.



BY LUCRETIA C. RAMSEY, AGE 16. (SILVER BADGE)



BY SALEM HYDE, 2ND, AGE 17

"MY MOST ARTISTIC PHOTOGRAPH"

A TEST OF FRIENDSHIP

BY RUTH ERNESTINE COOK (AGE 11)

ALL the animals were excited. Reddy Fox had proclaimed that he would be a friend to Peter Rabbit. Peter only chuckled as he heard this.

"That promise will soon be broken," he assured Johnny Chuck. "Reddy is sly, but I know his ways; we 'll soon see if he keeps that promise, shall we, Johnny?"

"But how?" Johnny asked.

"Out in the dump I saw some old cotton that would do very well for a mimic rabbit," Peter explained, "and we can make one and put it in front of Reddy's house. I 'll stand behind the big bush and talk to him; do you see?"

"I 'm sure I do, and I think it will be a great trick," Johnny said decidedly.

"I 'll go and get the cotton now so we can finish it by to-morrow evening," Peter called, as he scurried out of sight.

Next evening, two little furry creatures, with an apparently lifeless object between them, neared Reddy's home.

Suddenly a sound was heard—not much of one, just enough to alarm these furry little animals. Dropping the mock rabbit where Reddy could be sure to see it, they tripped into the shadows.

"Hello, Reddy!" exclaimed Peter, while Reddy thought it was the mock Peter, "I hear you have proclaimed a truce of friendship."

"Peter Rabbit, I 've got you this time!" he snarled; "I 've got you!"

But Reddy had a surprise coming to him, for the supposed Peter was, of course, made of cotton, and Reddy was disgraced forever.

OVER THE HILL

BY RUTH MUNSON (AGE 16)

(Silver Badge)

To the top of the hill and over, lass,  
Join hands and climb with me,  
For the sun rides high in the heavens blue,  
And the hours on swift wings flee.

What tho' the way be stony, lass,  
Tho' the road be long and steep,  
With a song and a heart for any fate,  
We go forth the tryst to keep.

At the top of the hill is glory, lass,  
Its flowers still wet with dew,  
While over the hill lies peace, lass,  
Content for me and for you.

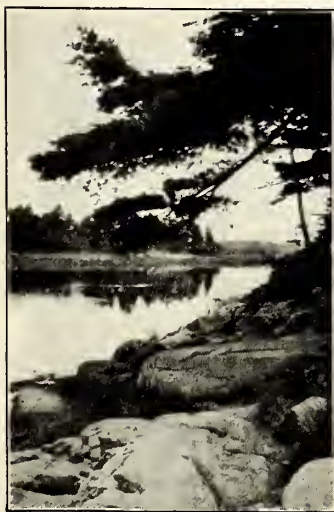

BY ROBERT K. CHISHOLM, AGE 15 (SILVER BADGE)



BY JULIA DODGE, AGE 13



BY CAROLINE N. HAZELTON, AGE 14

"MY MOST ARTISTIC PHOTOGRAPH"



## OVER THE HILLS

BY MARY SCOTT (AGE 8)

OVER the hills I love to roam,  
 Over the hills around my home.  
 Over the hills where cattle graze,  
 Over the hills in wonder I gaze.  
 Over the hills grow meadow flowers,  
 Over the hills come soft summer showers.  
 Over the hills some day I 'll climb to see the sights  
 so queer,  
 Over the hills and home again, back to Mother  
 dear.



"MY MOST ARTISTIC PHOTOGRAPH." BY L. O. FIELD, AGE 16  
 (GOLD BADGE. SILVER BADGE WON JUNE, 1922)

## A TEST OF FRIENDSHIP

(A True Story)

BY FLORENCE ROEVER (AGE 15)

IT was during the early part of the fourth century, B. C., that Pythias, a Syracusan, was condemned to death by the elder Dionysius, tyrant of Syracuse. He begged to be allowed to return home, so as to arrange his affairs and see his family. This he was allowed to do, on condition that his friend Damon would act as a hostage.

The day of the execution arrived, and Damon, sitting alone in his dungeon, was visited by Dionysius, who reminded him that the hour of his death was near. Damon remained undisturbed, saying that Pythias would return in time.

Hours and minutes flew by rapidly, and Damon was led forth to the place of execution. Suddenly, there was a great commotion in the crowd, and, dashing in, came Pythias, breathless and speechless.

True to his promise, and in the midst of the greatest difficulties, he had returned, just in time to save Damon from death. Struck by so noble an example of friendship, the tyrant pardoned Pythias, and asked to be allowed to join them in their sacred fellowship.

## A TEST OF FRIENDSHIP

BY MARTHA McCOWEN (AGE 11)

ONCE in Rome there was a poor slave named Androclus. He was treated so cruelly by his master that at last he decided to run away. He ran for a long way into a dense forest, until at last he sank down, feeling safe in the quiet solitude of the woods. Lying down in a cave, Androclus was soon sleeping soundly. After an hour had passed, he was awakened by a roaring which seemed to be drawing nearer every moment. Finally a lion rushed in. Androclus was very

much afraid, for he felt sure the lion would kill him. Then he saw that the lion was not angry, but that his foot seemed to be hurting him. Lifting the injured paw, Androclus found a thorn stuck deep in the lion's foot. With a quick jerk, he pulled out the thorn.

The king of beasts was very grateful to his benefactor, so for many days Androclus lived with his new friend, until one day, when the lion was out in the forest, some soldiers, who knew that Androclus was a runaway slave, passed through the woods; so they took him back to Rome.

Now there was a law that any slave who ran away should be forced to fight a hungry lion. So poor Androclus was brought out before a large crowd to pay this penalty. Then a door was opened and a half-starved lion rushed out. Androclus closed his eyes and fell to the ground. Suddenly, he was amazed to feel his face being gently touched by something soft and warm. Opening his eyes, he gave a cry of joy, for he had recognized his old friend, the lion of the cave.

The onlookers were greatly surprised when Androclus told his story. He ended by saying with a smile, "I was kind to him, so he refused to devour his old friend, no matter how hungry he was."

Then the people cried out, "Live and be free!" So Androclus and the lion went back to the forest to live happily together.

## "OVER THE HILLS"

BY RHODA MARY GONZALEZ (AGE 10)

OVER the hills of childhood,  
 When childish pleasures wane,  
 Into a new and different world,  
 Through sunshine and through rain,

Love and joy will pass you by,  
 Pain and sadness too;  
 Over the hills of childhood  
 A new world dawns for you.

## SPECIAL MENTION

A list of those whose work would have been used had space permitted:

PROSE	VERSE	
<i>Esther R. Girton</i>	<i>Frances Luce</i>	<i>Virginia Dewey</i>
<i>Miriam Abelson</i>	<i>Hoyt Hilton</i>	<i>Eleanor Byers</i>
<i>Bernard Leibson</i>	<i>Nancy Hodgkin</i>	<i>Virginia Clark</i>
<i>Ruth Atcheson</i>	<i>Molly Bevan</i>	<i>Shirley Woehler</i>
<i>Elizabeth B. Clarke</i>	<i>Elizabeth Botsford</i>	<i>Helen Calvoressi</i>
<i>Virginia Hammon</i>	<i>Alice H. Frank</i>	<i>Blanche Zellife</i>
<i>Marion D. Ward</i>	<i>Louise Hall</i>	<i>Geraldine</i>
<i>Margaret P.</i>	<i>Jane Custis</i>	<i>Fitz-Gibbons</i>
<i>Coleman</i>	<i>Bradley</i>	<i>Elizabeth Brainerd</i>
<i>Gertrude Green</i>	<i>Elizabeth Field</i>	<i>Elmira Horning</i>
<i>Elizabeth Evans</i>	<i>Elizabeth N.</i>	
<i>Hughes</i>	<i>Adams</i>	<b>DRAWINGS</b>
<i>Rose Ginsberg</i>	<i>Brenda H. Green</i>	<i>Jane Smith</i>
<i>Leo Sperting</i>	<i>Evelyn Crow</i>	<i>Elizabeth Goodwin</i>
<i>Pauline Garber</i>	<i>Eunice W.</i>	<i>Winifred V. Collins</i>
<i>Mary K. Shaw</i>	<i>Thompson</i>	<i>Florence Riefler</i>
<i>Florence H. Pierson</i>	<i>Margaret Humphrey</i>	<i>Mary Kent-Miller</i>
<i>Nancy Hamilton</i>	<i>Margaret Durick</i>	<i>Elease Weins</i>
<i>Elizabeth</i>	<i>Mary F. Mong</i>	<i>Edith Sollers</i>
<i>McCullough</i>	<i>Elinor Cobb</i>	<i>Florence Mack</i>
<i>Frances Durbin</i>	<i>Mary V. Lay</i>	<i>Elizabeth Tracy</i>
<i>Eleanor</i>	<i>Evelyn Jaffe</i>	<i>Mildred M. Harris</i>
<i>McCormick</i>	<i>Miriam Gantz</i>	<i>Ellen L.</i>
<i>Erma Williams</i>	<i>Jean Haynes</i>	<i>Carpenier</i>
<i>Clara Mears</i>	<i>Katherine Foss</i>	<i>Margaret L.</i>
<i>Harold Rhoades</i>	<i>Caroline Harris</i>	<i>Westoby</i>
<i>Mary Rumely</i>	<i>Virginia P.</i>	<i>Marjorie E. Root</i>
<i>Isabel Burtis</i>	<i>Broomell</i>	<i>John D. Elwyn</i>
<i>Elizabeth</i>	<i>H. Bowen White</i>	<i>Virginia Snedeker</i>
<i>Naumberg</i>	<i>Virginia</i>	<i>Dorothy E. Cornell</i>
<i>Dorothy Burnett</i>	<i>Middlebrook</i>	<i>Gladys Blakeley</i>
		<i>Arthur Draper</i>

PHOTOGRAPHS

Frances Susskind  
Jean Saliere  
Eleanor Dwight  
Jean E. Hays

Louise Eisenlohr  
Bettina Cramer  
Bertha Clark  
Alice D. de Forest  
Pearl B. Wells

Mary T. Shepard  
Jeannette Latta  
Sally Dennett  
Mildred Jackson  
Blanche Gaillard

ROLL OF HONOR

A list of those whose contributions were deserving of high praise:

PROSE

Lucille Ackerman  
Marjorie Burdett  
Alice M. Kistler  
Charlotte A. Raible  
Dorothea Tucker  
Selma B. Jones  
Phyllis B. Smack  
Elizabeth Stuart  
Dorothy Bull  
Kathryne E. O'Connor  
Alice Winston  
Clinton H. Reynolds  
Dorothy Timmons  
Alva Christiansen  
Verne Weed  
Charlotte B. Gottlieb  
Dorothy Crook  
Virginia Zollinger  
Margaret F. Weil  
W. F. Ball  
Mary Beals  
Eleanor Meeks  
Margaret True  
Austin Evans  
Ruth McL. Matfield  
Paul Yoder  
Florence B. Pollock  
Ruth S. Wheeler  
Ruth D. Alpert  
Winifred Merrill  
Helen M. Duer  
Claire McCullough  
Jeanne Muller  
Isobel McCreery  
Amy Dunhaupt  
Henry Escher, Jr.  
Ruth Wilkinson  
Edith Eardley  
George Corsun  
Marucci Capuzzi  
Madeline Kennedy  
Margaret Nichols  
Isabel F. J. Carpenter  
Walter A. Collins

VERSE

Elizabeth M. Swain  
Gertrude Herrick  
Theodora Gott  
Margaret L. Griffith  
Clarice Webb  
Betty Perkins  
Beatrice Wadhams  
Elizabeth Hardaway  
Arvella Wickerham  
Elizabeth Best  
Fannie Blank  
Dorcas E. Gallaher  
Luna Bard  
Martha Bragaw  
Betty Snowden  
Caroline G. Thompson  
Alice Hooper  
Bernice M. Bowen  
Eleanor Thiel  
Mary E. Luce  
Edward Samolinski  
Emily Frank  
Elizabeth Brooks  
George Oles  
Elizabeth M. Sanger  
Elizabeth Footer  
Helen A. Brooks  
Mary Caroline Bentley  
Maxine Wiley  
Charlotte L. Groom



"A HEADING FOR SEPTEMBER." BY TERESA DE ARTEAGA, AGE 12. (SILVER BADGE)

Mabel Gibberd  
Madelaine Karpeles  
Ruth Holly  
Edwards  
Margaret G. Clinch  
Frances Beggeman  
Donald Forsyth  
Helen West  
Edith G. Kline  
Ruth Harris  
Nancy Ellen Giguette  
Jennie Gussow  
Louise Hoff  
Esther Walcott  
Patricia Laurence  
Henry Nevin  
Alice Laster  
Helen L. Whitehouse  
Dorothy Kaufman  
Catheryn Heidelberger  
Ruth V. Dawson  
Eleanor Avery  
Ida Putz  
Marjorie R. Jackson  
Ruth Bentley  
Herbert Thomas  
Alice M. Johnson  
Lois A. Jameson

DRAWINGS

Lawrence Kittredge  
Sarah K. Stafford  
George Cunningham  
Wiggins  
Mary Newell  
Schultz  
Rubie A. Chapman  
Madeline Dyer  
Elizabeth Bush  
Harriet Anne Duell  
Harriet H. Witman  
Mary W. Hawke  
Muriel Doe  
Ward Randall, Jr.  
Milicent Laubenheimer  
Edmund Strudwick  
Lalia Simison

Thelma Kem  
William C. Putnam  
Elizabeth Runkle  
Elizabeth F. Flinn  
Esther Robinson  
Emelyn Wyse

PHOTOGRAPHS

Frances Robbins  
James C. Perkins, Jr.  
Faith H. Poor  
Mary McDowell  
Smith  
Frances Tomkinson  
Blanche Holland  
Eleanor Cruse  
Frances Kimball  
Hazel Kuno  
Elinor Horman  
Mary Reeve  
Janet Rosenwald  
Virginia Blake  
Muriel Ward  
Thomas N. Lombard  
George S. Read  
Josephine Howell

PUZZLES

C. LeRoy Custer  
Nancy West  
Martha Fisher  
John W. Bodine  
Dick Cosmos  
Cornelia B. Smith  
Helen S. King  
Gerard G. Cameron  
Betty Dow  
Frances D. Clark  
Allan Langerfeld  
Hope M. Wells  
M. Willard Messler  
Peggy Bower  
Virginia C. Rodney  
Margaret Cole  
Mabel B. Austin  
Mildred Cohen  
Catharine Beard  
Eunice Collupy  
George R. Kennedy

WHAT THE LEAGUE IS

THE ST. NICHOLAS LEAGUE is an organization of the readers of the ST. NICHOLAS MAGAZINE.

THE LEAGUE motto is "Live to learn and learn to live."

THE LEAGUE emblem is the "Stars and Stripes." THE LEAGUE membership button bears the LEAGUE name and emblem.

THE ST. NICHOLAS LEAGUE organized in November, 1899, became immediately popular with earnest and enlightened young folks, and now is widely recognized as one of the great artistic educational factors in the life of American boys and girls.

THE ST. NICHOLAS LEAGUE awards gold and silver badges each month for the best original poems, stories, drawings, photographs, puzzles, and puzzle answers.

PRIZE COMPETITION, No. 274

Competition No. 274 will close October 1. All contributions intended for it must be mailed on or before that date. Prize announcements will be made and the selected contributions published in ST. NICHOLAS for January. Badges sent one month later.

Verse. To contain not more than twenty-four lines. Subject, "The Changing Year."

Prose. Essay or story of not more than three hundred words. Subject, "Safety First."

Photograph. Any size, mounted or unmounted; no blue prints or negatives. Young photographers need not develop and print their pictures themselves. Subject, "The Pet of the Family."

Drawing. India ink, very black writing-ink, or wash. Subject, "A Welcome Visitor," or "A Heading for January."

Puzzle. Must be accompanied by answer in full. Puzzle Answers. Best and neatest complete set of answers to puzzles in this issue of ST. NICHOLAS. Must be addressed to THE RIDDLE-BOX.

No unused contribution can be returned unless it is accompanied by a self-addressed and stamped envelop of proper size to hold the manuscript or picture.

RULES

ANY reader of ST. NICHOLAS, whether a subscriber or not, is entitled to League membership, and upon application a League badge and leaflet will be sent free. No League member who has reached the age of eighteen years may compete.

Every contribution, of whatever kind, must bear the name, age, and address of the sender and be indorsed as "original" by parent, teacher, or guardian, who must be convinced beyond doubt—and must state in writing—that the contribution is not copied, but wholly the work and idea of the sender.

If prose, the number of words should also be added. These notes must not be on a separate sheet, but on the contribution itself—if manuscript, on the upper margin; if a picture, on the margin or back. Write in ink on one side of the paper only. A contributor may send but one contribution a month—not one of each kind, but one only; this, however, does not include "competitions" in the advertising pages or "Answers to Puzzles."

Address: "The St. Nicholas League," The Century Co.

353 Fourth Avenue, New York.



# THE LETTER-BOX

CRISTOBAL, CANAL ZONE.

DEAR ST. NICHOLAS: I live on the Canal Zone so it is quite different from the States. Here in Panama you meet nearly all the different races of the world. The negro predominates, because they were brought here by the United States Government to work on the canal.

My father works at the coaling plant, where they receive coal from colliers which bring it down from the States. Sometimes, when I go over with my father, I wish the great piles of coal were of snow instead.

We live near the beach, and in front of our house is a U. S. Government wireless station. The towers are only three hundred feet high; but at Darien they are six hundred feet high. Across a little bay from our house is an army post, a submarine base, and an aeroplane base.

I was born in a little town named Tavernilla in the Canal Zone, the last baby to be born there before the Government tore the town down and the water was let in. It is now in the middle of the canal.

Yours sincerely,  
GRETCHEN PALM (AGE 10).

IDAHO FALLS, IDAHO.

DEAREST MAGAZINE IN THE WORLD: I suppose you know what I'm going to tell you, but I shall say it anyway—that you are the dearest and best magazine I have ever read.

You can't imagine what a help you are. In civics class we use you a lot, for your WATCH TOWER is very interesting. Then, just a little while ago, our grammar teacher liked the English play, "I'll Try," so well that she let us give it for a public benefit.

We have been to Yellowstone Park four times and every time it seems more interesting than before. The last visit we made there we had a real adventure. We were all sleeping out in the open when we heard an awful noise, and lo and behold, a great big grizzly bear had visited us! However, I don't think it was so much us as the ham we had that it visited. All the men jumped out of bed and, in their pajamas, they started jumping and yelling to scare him. Mr. Bear climbed up the tree; then when we began shaking the tree, he jumped from that tree to another, from there he jumped into the Yellowstone River and swam across! I did n't know bears were acrobats, but I do now.

Wishing you "oodles" of prosperity,  
Devotedly,  
RUTH CALDWELL (AGE 13).

NASHVILLE, ARK.

DEAR ST. NICHOLAS: I can't express my appreciation of you. You were given to me as a Christmas gift about two years ago, and I like you better every number.

One month I took you to school with me, and all of the girls wanted to read you. (Your bright and beautiful covers would naturally attract any one.) They were all crazy about you; and after my teacher had read you, she was so pleased that she gave the room a year's subscription for Christmas.

I was very interested in "The Hill of Adventure," and was anxious to see how it was going to end.

Your devoted reader,  
MARY CALLAWAY RAMSEY.

CARROLLTON, MO.

DEAR ST. NICHOLAS: I have taken you since January and have never enjoyed any magazine half so much as I have you. My aunt gave you to me for a Christmas present, and never—no matter how long she had tried—could she have found a better present.

The reason that I enjoy you so much is because you help me in my school work. I am a freshman in high school.

The WATCH TOWER is very interesting. My father and mother enjoy the book as well as do my little brother and myself. I also enjoy all of the stories. "The Inca Emerald," I believe, is my favorite, because it is about South America. Year before last my uncle went to South America and had what he termed a very adventurous time. There were seven men who started out, and only three returned; the others died with jungle fever. My uncle had it, but recovered. He brought me back some llama,—called by the natives "yama"—rope, and also a copper ingot.

One of your many readers,  
MARIE ELIZABETH STIPP (AGE 14).

HAMILTON, BERMUDEA.

DEAR ST. NICHOLAS: You have been one of my favorite companions for five years, and I don't know what I should ever do without you. All your interesting stories I love equally well, and I read you from cover to cover, including the advertisements. I adore the LEAGUE too, and am proud to say that you have printed some of my stories.

I spent all of the past winter down here in Bermuda, and a more beautiful and interesting place could never be imagined. Really, the intense coloring of the sky and water is unbelievable, unless one has seen it, the latter being all shades of clear blues and greens, and, off the reefs, a pinkish-purple.

Among the many exquisite tropical trees and flowers we have here, are the magnificent clematis. They grow in great profusion all over the islands, and now being heavily laden with gorgeous shades of pink blossoms, the air is literally sweet with their intense fragrance.

There are a great many places of interest to see here, the old town of St. Georges, where lies buried in the "Somers Garden," the heart of Sir George Somers, who settled there in 1609, the coral-rock atolls, the fascinating caves with the marvelous stalactite and stalagmite formations, the tropical sea-gardens, besides many more wonderful phenomena.

I love to imagine, too, "Pirate Lore," as I live in a cottage built in 1653 by a buccaneering captain to entertain his wild comrades in!

Wishing you all success in the future, dear magazine, I remain,

Always your loving reader,  
ELIZABETH EVANS HUGHES (AGE 14).









*Madge Evans*  
**HATS**  
*for Little Ladies*

THESE are the smart Hats every girl 4 to 17 loves to wear! They make her look most charming; they wear longest; and are priced reasonably.

If you do not know the store in *your* locality that sells Madge Evans Hats, we shall be glad to send you its address.

MADGE EVANS HAT CO.,  
602 Broadway, New York City

*Send for This  
Charming Booklet—*

*Just write: "Dear Madge: Send me your new booklet, 'What Makes a Girl Popular,' and I promise to look for a Madge Evans Hat before buying my new Autumn Hat."*







*A. G. Spalding & Bros.*



## Ready, All-America?

Autumn and School and Foot Ball will soon be here.

Spalding stores are ready for the season.

The Spalding Official Intercollegiate Foot Ball No. 15 is the ball used in practically all important college matches.

Balls—Uniforms—Headgear—Jerseys—Shoes—every equipment for the player.

If you cannot call, ask us to send a catalogue.

**Spalding's Official Foot Ball Guide.**  
Edited by Walter Camp. Price 25c.

**How to Play Foot Ball. One of the most useful and practical books on foot ball ever published.** Price 25c.

### A. G. SPALDING & BROS.

New York, Newark, Philadelphia, Boston, Pittsburgh, Rochester, Albany, Buffalo, Syracuse, Baltimore, Atlanta, Jacksonville, New Orleans, Washington, Chicago, Indianapolis, Cincinnati, Cleveland, Columbus, Detroit, Louisville, St. Louis, Kansas City, Milwaukee, Minneapolis, St. Paul, Des Moines, Dallas, San Antonio, San Francisco, Oakland, Seattle, Los Angeles, Portland, Salt Lake City, Denver, Omaha, Montreal, Toronto.

# MARVELOUS MOVIES

for the HOME, SCHOOL, CHURCH

CLUB  
CAMP  
OFFICE

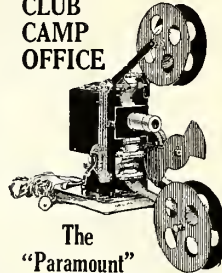

The  
"Paramount"  
Motion Picture Machine

(Patents pending)

complete, weighs only twelve (12) pounds.

The most beautiful and best constructed motion-picture machine for the price in the world. Shows the same clear, crisp movies the big theatres exhibit. Child or grown-up can easily operate the **PARAMOUNT** without any previous experience. Do not confuse this machine with toys at the same price. The **PARAMOUNT** is NOT a toy. It is a real, wonderful, guaranteed machine made of best materials by skilled workmen.

Just attach the electric plug to any electric current, turn the crank and the show is on. The entire outfit, complete, weighs only twelve (12) pounds.

Our Film Service is Available

Price - \$35.00

(Sent anywhere—ready for use)

Inquire at your nearest dealer. If he cannot supply you write us mentioning dealer's name and we will send you our free catalogue. Remember there is no substitute for the **PARAMOUNT**.

**PARAMOUNT MFG. CO.**

Box 1371, Dept. 54-C, Boston, Mass., U.S.A.

## YANKEE SPEED BIKE

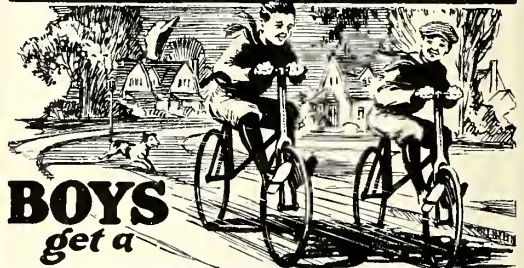

**BOYS**  
get a

## YANKEE SPEED BIKE

Here is a coaster that looks like a real bicycle—a coaster built for speed. Roller bearing wheels with wire spokes and rubber tires. Adjustable leather covered spring saddle. Beautifully enameled in green and red. Sizes for boys 5 to 14 years old. Price only \$6.00, express paid. Satisfaction guaranteed or money back.

### YOU CAN EARN ONE

A few boys in every city can pay for their Yankee Speed Bike by doing a little work for us. Ask us about it.

The Ad-A-Toy Corporation

1804 Columbus Ave.

Anderson, Indiana

**GOES LIKE THE WIND**

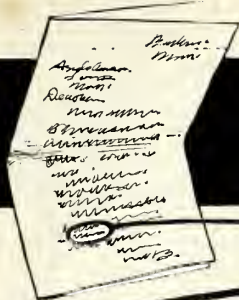

"Cutting teeth is made easy"

Oakland, Neb.  
Feb. 28, 1920.

Anglo-American Drug Co.,  
215-217 Fulton St.,  
New York, N. Y.

Gentlemen:

I am more than glad to tell you of the experience and result I have obtained from your wonderful Baby Medicine.

Our first baby cried and was so fretful. Nothing I could do seemed to relieve her and bring natural results until she was past twenty months; then I was told by a friend of Mrs. Winslow's Syrup. After a few doses, I could see a wonderful result.

Our second baby is now seven months old and has never given us a moment's trouble. The first and only thing she has ever taken was Mrs. Winslow's Syrup. She has four teeth and is always smiling and playing. *Cutting teeth is made easy* by the use of Mrs. Winslow's Syrup.

Most sincerely,

(Name on request)

# MRS. WINSLOW'S SYRUP

*The Infants' and Children's Regulator*

This safe, pleasant, purely vegetable compound keeps baby healthy and contented during the trying teething period, by regulating the bowels and relieving diarrhoea, colic, flatulency and constipation. Guaranteed non-narcotic, non-alcoholic. Open formula on every label. Write for booklet of letters from grateful mothers.

*At all Druggists*

ANGLO-AMERICAN DRUG CO., 215-217 Fulton St., New York

General Selling Agents: Harold F. Ritchie & Co., Inc.

New York, Toronto, London, Sydney



# Holeproof Hosiery



## For Brother Bill and Sister Sue

—and for all boys and girls who play hard, there is no hosiery quite like Holeproof. Climb, slide all you like, it won't tear or rip. And mother will be happy, too, for it saves her so much darning.

Mother will find that most stores carry Holeproof for boys and girls in full lengths, three-quarter lengths with roll tops, and half-hose in cotton, mercerized lisle, fibre-silk, and silk. But if it is not obtainable locally, write to us for price-list and purchase it direct.

**HOLEPROOF HOSIERY CO., Milwaukee, Wis.**  
Holeproof Hosiery Co. of Canada, Limited, London, Ont.

**ROCHE'S** HERBAL **EMBROCATION**  
RELIEVES SAFELY AND PROMPTLY

**CROUP**  
OR  
**WHOOPIING COUGH**

Also wonderfully effective  
in Bronchitis, Lumbago  
and Rheumatism.  
All druggists or

**W. EDWARDS & SON**      **E. FOUGERA & CO.**  
London, England      90-92 Beekman St. N. Y.



BACK TO  
SCHOOL ON

**KoKoMo**

KOKOMO STAMPED METAL CO. Kokomo, Indiana

## Ask Your Dealer —

for KoKoMo Ball Bearing Roller Skates with the truss frame construction and the "rocking chair" movement. They are "Young America's First Choice."

# SKATES

## What the Newspapers are Saying About W. F. Alder's

### "The Isle of Vanishing Men":

"THIS time it is the out-of-the-way island of New Guinea to which the author takes us in a most delightful book of his experiences. The island is inhabited by cannibals, and while he wished to go there to study the natives, an unexpected shipwreck made it impossible for him to get away. He lived right in the village with the cannibals and learned much about them that has never been told before. Every page of the book is full of interesting and incredible things."—*St. Louis Globe-Democrat.*

### "The Isle of Vanishing Men"

is published by

**THE CENTURY CO., 353 Fourth Avenue  
NEW YORK CITY**

And is sold at all bookstores

The price is \$2.00

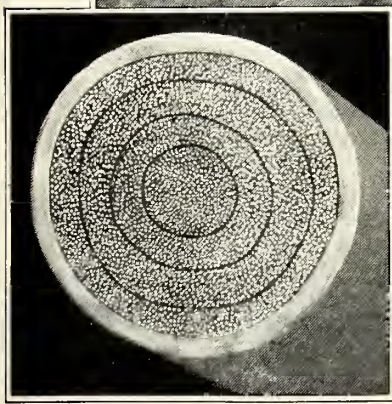
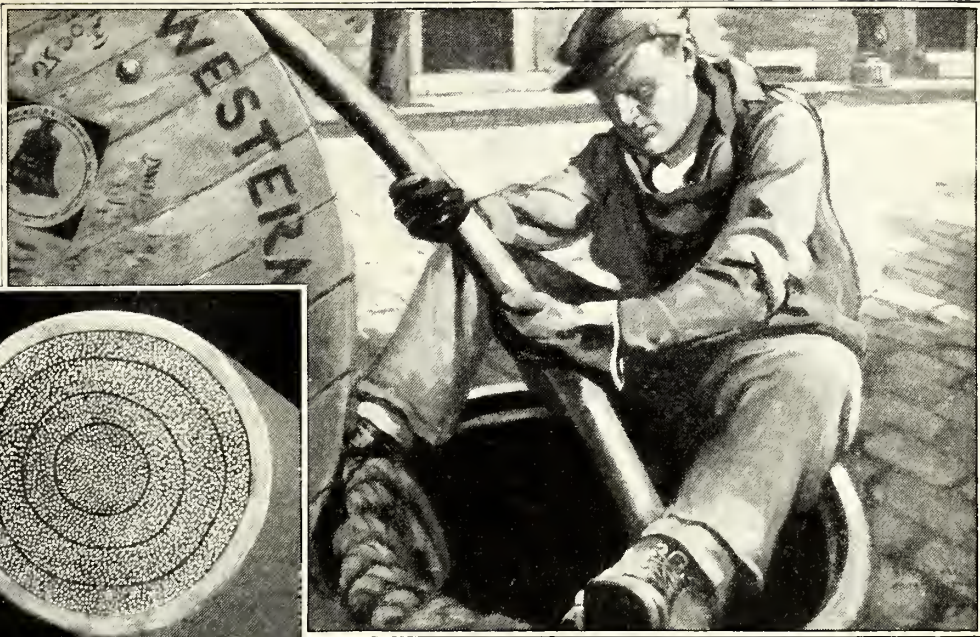

2400 telephone wires in a cable little larger than a man's wrist.

# Science keeps down costs

When the Bell System installed its first successful telephone cable, fifty wires was the largest number that could be operated in a single cable without "cross-talk" and other interference. Today it would require 48 cables of the original type to accommodate the number of wires often operated in one cable.

Without this improvement in cable, the construction of new underground and aerial lines would have cost the Bell System upwards of a hundred million dollars more than has actually been spent. In addition, the cost of maintenance would have been greater by eighteen million dollars a year. These economies in the Bell System mean a saving in telephone rates to each individual subscriber.

In all branches of telephone practice

science has similarly contributed to economy. Even in such a comparatively small item as switchboard cords, improvements have reduced the cost of renewal by four million dollars a year.

Every new telephone added to the Bell System increases the usefulness of all telephones, but this multiplication tends likewise to increase the complications and the expense of service. The scientists of the Bell System, to offset this tendency, are constantly called upon to develop new devices which simplify complications and keep down costs.

By virtue of a united system the benefits of these improvements are shared by all subscribers—and the nation is provided with the best and cheapest telephone service in the world.

" BELL SYSTEM "

AMERICAN TELEPHONE AND TELEGRAPH COMPANY  
AND ASSOCIATED COMPANIES

*One Policy, One System, Universal Service, and all directed toward Better Service*







Above, parts clipped together ready for covering  
At left, completed Airplane in flight

## Every Boy's IDEAL Airplane

A New, Quick and Easy Way for You to Make a Flying Model Airplane

HERE'S a new idea in Model Airplanes; nothing like it ever produced before. Every Boy can now have days of real fun flying his own Model Airplane without any trouble in building it. Just clip the ready-formed parts of "EVERY-BOY'S" Airplane together (no nails, wire or tools needed), put on the covering and your 'plane is finished. No fuss, no failure! Your 'plane will be ready for the air in two hours. A strong, sturdy 'plane that will stand hard knocks and with which you can have endless outdoor fun. 31-2 ft. wing spread; and guaranteed to rise from the ground and fly in the air under its own power.

"EVERY-BOY'S" Airplane comes all ready to clip together, with full assembling and flying instructions. Complete Outfit, \$6.00. Ask your Toy Store for "EVERY-BOY'S" Airplane; or we will fill your order direct upon receipt of price and guarantee satisfaction or money returned.

Catalog of IDEAL Model Aeroplanes and Supplies gives full description of "EVERY-BOY'S" Airplane and also contains interesting information about Model Aeroplanes and the easiest way to build and fly them. Sent postpaid for 5 cents.

**IDEAL AEROPLANE & SUPPLY CO.**  
65 Houston Street, West New York City

## You Need One for School



NOW you need a good timepiece, for school days. Most up-to-date boys have an Ingersoll.

Ingersoll Watches have made right timekeeping, at reasonable prices, famous. Tens of millions sold.

Sturdy, reasonable, reliable, Ingersoll Watches carry a sound guarantee. A new Ingersoll always costs comparatively little, in the event of possible loss, theft or breakage. A complete line from \$1.50 to \$9.

**INGERSOLL WATCH CO., Inc.**  
New York Chicago San Francisco



**Ingersoll**  
Yankee  
\$1.50  
With Radiolite  
Dial \$2.50

10 Buys  
\$100  
Millions  
Billions  
in use  
to-day



**Engel "Art Corners"**  
NO PASTE NEEDED  
Use them to mount all kodak pictures, post cards, clippings in albums

Made in Square, Round, Oval, Fancy and Heart of black, gray, sepia, and red gummed paper. Slip them on corners of pictures, then wet and stick. QUICK-EASY-ARTISTIC. No mugs, no fuss. At photo supply, drug and stat'y stores. Accept no substitutes; there is nothing as good. 10c brings full pkg. and samples from Engel Mfg. Co. Dept. 113-J 4712 N. Clark St., Chicago

## Wee Hoppy Toad Tales !

SPICY ANIMAL TALES that will delight the kiddies. Each tale has a moral. Attractively bound and illustrated. Children will read and reread these fascinating tales with ever-increasing enjoyment. Price 50 cents. Please Send Money Order. It insures safety for remitter.

**WILLIAM A. HENNESSEY**  
95 High Street Portsmouth, New Hampshire

## Delivered to You Free

for 30 days trial on approval. You can have your choice of 44 Styles, colors and sizes of the famous **RANGER Bicycles. Express prepaid. Factory-to-Rider** Prices save you \$10 to \$25 on your bicycle.

**12 Months to Pay** easily save the small monthly payments. Parents often advance first payment.

**Tires Lamps, wheels and equipment, low prices. Send No Money, do business direct with makers.**



**Mead Cycle Company**  
Dept. B15 Chicago

Write today for free Ranger Catalog, factory prices and marvelous easy payment terms

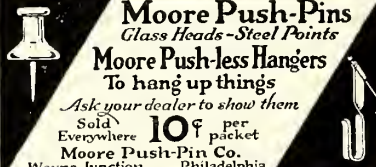

**Moore Push-Pins**  
Glass Heads - Steel Points  
**Moore Push-less Hangers**  
To hang up things  
Ask your dealer to show them

Sold Everywhere **10¢** per packet  
**Moore Push-Pin Co.**  
Wayne Junction Philadelphia

## BOYS, YOU CAN MAKE BIG MONEY

selling THE BOYS' MAGAZINE each month. Write us today for 5 copies. Send no money. Address

**THE SCOTT F. REDFIELD CO., Inc.**  
7270 Main St. Smethport, Pa.

## Reliability

is the key-word of the ST. NICHOLAS advertisements.

You can also count on the quality of goods advertised in these pages.

# ABINGDON

**B**OOKS are good companions for the in-between-times, the rainy days or quiet hours at the end of busy days. Across their white pages are flung tales of far-away peoples and strange adventures; pictures of other lands and of this big country where we live; stories of hero men and women.

How easily they come to our acquaintance between the covers of a book! Good books are just as full of stirring adventures as poor ones. Abingdon Books are tales you will be proud to show your friends on your own particular book-shelf.

Here are just a few of the many good books for boys and girls from the Abingdon Press. Any good bookstore has them for sale.

## *Treasures for Your Book-shelf*

### OVERLAND FOR GOLD

*By Frank H. Cheley*

"Mr. Cheley writes chiefly for boys—real American boys, and this book is a story of the Colorado gold excitement, the days of wagon trains, Indian attacks, desert, mountains and death. Action is found on every page, and its historical setting gives it value as well as charm."—Pittsburgh Leader.

Price, net, \$1.50, postpaid.

### THE BOY WHO LOST HIS NAME

*By Christine Ware*

"In this story that parallels 'The Man Without a Country' and is sure to interest boys, 'the boy' cheats in an examination, plays tricky baseball and bullies a schoolmate. His father punishes him by taking his name away. How the boy gets it back forms an absorbing story."—The Continent.

Price, net, \$1.00, postpaid.

### A TRAVEL BOOK FOR JUNIORS

*By Helen Patten Hanson*

"A very delightful book that would necessarily find a warm welcome in every Christian home is this book of travel. Vivid description in simple language of a boy's experience in Palestine and Egypt since the Great War, it will interest any student of the Bible. It is beautifully printed and contains thirty maps and illustrations. The author has the happy art of telling just what one wishes to know."—Boston Evening Transcript.

Illustrated. Price, net, \$1.25; by mail, \$1.37.

### IN NAAMAN'S HOUSE

*By Marian MacLean Finney*

This romance of the land of Israel is full of color and interest and makes the people of an almost forgotten yesterday live again in the throbbing today. In the center of this captivating story of adventure and love stands the captive maid, who, through a series of strange experiences, finds herself in the household of Naaman.

Price, net, \$1.75, postpaid.

### THE "LITTLE FOLKS" SERIES

*By Dorothy Donnell Calhoun*

Fascinating books for children, with a distinct educational value.

#### LITTLE FOLKS IN HISTORY

Mrs. Calhoun knows just how to write for children, and these sixteen fascinating stories, with the charm of romance and history, will be eagerly read by the little ones. Illustrated.

Four books. Per book, net, 50c.

#### LITTLE FOLKS IN ART

Happy the children in whose hands these books are placed. In a plain, clear, simple style they tell about the famous artists and the stories of the pictures themselves. Illustrated.

Four books. Per book, net, 50c.

#### LITTLE FOLKS OF THE BIBLE

Portrays child life from the Bible, and tells in a pleasing style the stories of Isaac, Joseph, Benjamin and other little folks we have learned to love in sacred history. Illustrated.

Four books. Per book, net, 50c.

#### LITTLE FOLKS FROM LITERATURE

David Copperfield, Lorna Doone, Paul and Virginia and others of the best juniors. . . . a collection of stories and poems which cultivate a desire for the best books. Illustrated.

Four books. Per book, net, 50c.

At the Better Bookshops

## THE ABINGDON PRESS

NEW YORK

CINCINNATI



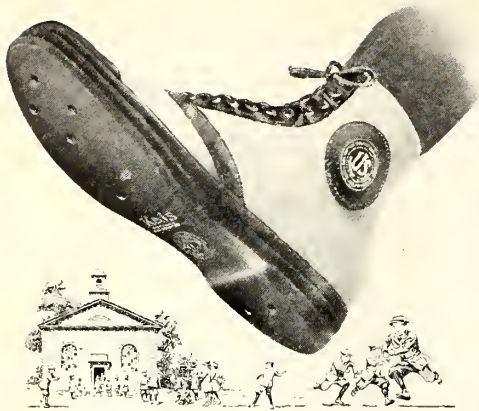

## Take vacation comfort back to school

**Y**OU need not start back to school in stiff heavy shoes. You will find all the fellows are still wearing their easy comfortable Keds every day.

The athletic-trim model above is one that is just right for school wear. It is made of a heavy tough canvas with suction soles or with corrugated or smooth soles. Sturdy reinforcements make it stand the gaff. This is only one of the many kinds of Keds made for boys and girls.

### *Why it will pay you to insist on Keds*

Keds soles are made of live, springy rubber grown on our own plantations. The tops are of fine canvas, light but strong.

Back of every pair of Keds are the skill and experience of the oldest and largest rubber organization in the world.

If your dealer does not have the type for your particular need, he can get it for you. But remember—Keds are made only by the United States Rubber Company. If the name Keds isn't on the shoes, they aren't real Keds.

Booklet, "Basketball," sent free if you write Dept. D-6, 1790 Broadway, New York.

**United States Rubber Company**



# Keds

*They are not  
Keds unless  
the name  
Keds is on  
the shoe.*

Trademark Reg. U. S. Pat. Off.

## Young People and Advertising

Why have scores of national advertisers been staunch supporters and steady users of ST. NICHOLAS for years?

**S**IMPLY because they realize the great potential buying power of these thousands of young readers. Our subscribers represent the best homes in the country, and the boys and girls in these families will soon be the influential citizens in their communities.

As a medium for advertising clothes, toys, books, etc., for boys and girls, ST. NICHOLAS stands alone. By appealing direct to the children you make the strongest possible bid for selling your product.

**ST. NICHOLAS MAGAZINE**

353 Fourth Avenue, New York City



## PHANTOM GOLD

By Kenneth Payson Kempton

☛ This is an absorbing story of the docks, the Atlantic coast and the open sea; and also of a boy who discovered through thrilling experience that all the pirates did not die with Captain Kidd.

☛ Those who saw "Phantom Gold" as a serial in *St. Nicholas* but did not read all of it will be glad to find the story in its entirety in book form. It is a book to read and recommend.

*Illustrated.* \$1.75



## WHISTLING JIMPS

By Edna Turpin

Author of "Treasure Mountain," etc.

☛ A fascinating story of the Alleghany Mountains, which the author knows intimately from years of living and working there. *Whistling Jimps* is a picturesque mountain boy who loves and is on friendly terms with birds and all the wild life of his native hills.

*Illustrated.* \$1.75

THE CENTURY CO.



## Mothers are Right

*Sensible Clothes are Smartest*

Who can add one bit to the natural beauty of girlhood?

Sensible, healthy looking Paul Jones Garments are just as smart as they are economical. You can get Paul Jones blouses of the finest materials that delight a young girl's heart for as little as \$2.00. Write for the latest Paul Jones Style Book with its suggestions for school wear. Address Dept. A-5.

MORRIS & CO., Inc.  
Baltimore, Md.

# PAUL JONES GARMENTS

"Quality First"





# ST. NICHOLAS STAMP PAGE

CONDUCTED BY SAMUEL R. SIMMONS

## THE MUSICIANS

PHILATELY is indebted to Austria for a beautiful new series of stamps. And not only are they worthy of note from an artistic point of view, but also for the reason that they are a departure from anything that we have had before in the way of



depicted. There is a sort of chronological order to be detected in the association of portrait and face-value. First is the 2½-kronen, a rich brown in color, showing the head of Joseph Haydn, who was born in Austria in 1732, and who became world-famous for his symphonies and

portraiture. We have had pictures of kings and emperors, statesmen and presidents galore. Now and then some one of prominence in other fields of importance has been shown. But here, honor is bestowed upon the arts—seven famous musicians of Austria are

other compositions. On the 5-kronen, dark blue, is shown a portrait of Mozart, born at Salzburg in 1756, the musical prodigy who played the piano at the age of four, and composed at the age of six. On the 7½-kronen, slate, is Ludwig van Beethoven. He was not born in Austria, but at Bonn, Germany, in 1770. However, as most of his life and musical work was associated with Vienna, and as he died and was buried in that city, perhaps Austria can have some claim to his fame. On the 10-kronen, violet in color, is Franz Schubert, who was born in the neighborhood of Vienna in 1797. He was, perhaps, the greatest composer of songs that the world has ever known. On the 25-kronen, dark green, is Anton Bruckner. He was not so world-famous as the musicians already mentioned, although he was the composer of many symphonies. He died in 1896. Now on the 50-kronen, red lilac, appears Johann Strauss, II, born in Vienna in 1825 and known as the "Waltz King." His name always suggests "The Blue Danube." The last of the series, 100-kronen, light brown, shows another less well known Austrian musician, Hugo Wolf. This writer of songs died not so very many years ago. As will be seen in the illustration, all the stamps in the series are of the same general design. At the top is the word "Oesterreich," and at the bottom is the value. In the centers are the portraits, surrounded by designs of very ornamental scroll-work. The whole effect is exceedingly artistic and pleasing. It has been a long time since we have seen such an attractive series of stamps. The face value of the stamps amounts to 200 kronen. This sounds rather expensive, but worse is to follow. It seems that this set was issued for some sort of charitable work. While there is nothing on the stamps to indicate their purpose, either postal or otherwise, we understand that while they may be used for postage at their face value only, yet the post-office sells them at ten times face, the difference being reserved for charity. Still, we should not be dismayed even at 2000 kronen. For this at the present rate of exchange amounts to only an insignificant sum as compared to its formidable appearance. We believe many a boy and girl will soon be the proud owners of this set.

## ANSWERS TO QUERIES

¶ ONE of our readers has a friend who claims to own a "Robinson Crusoe" stamp, and we are asked whether or not this statement is justifiable. In a way, the claim is a good one. In 1910, Chili surcharged four stamps "Islas de Juan Fernandez." While apparently these stamps were surcharged for that island itself, yet they were available for postage anywhere in Chili. Juan Fernandez is the prototype of *Robinson Crusoe*. ¶ We have been asked if we could give any information as to the meaning of the curious design upon the 1902 issue of Bulgaria. We have seen many copies of this stamp where the picture did not show very clearly. Then, too, the stamps are lithographed, which is not so clear-cut a printing as that of an engraved stamp. The design

(Concluded on second page following)

# THE ST. NICHOLAS STAMP DIRECTORY

is really a list of reliable Stamp Dealers. These people have studied stamps for years, perhaps they helped your father and mother when they first started their stamp collections. *St. Nicholas* knows that these dealers are trustworthy. When writing to them be sure to give your full name and address, and as reference the name of your parent, or teacher, or employer, whose permission must be obtained first. It is well also to mention *St. Nicholas Magazine*. Remember, we are always glad to assist you, so write to us for any information that will help you solve your stamp problems.



**TRIANGLE**

Scarce FIUME (like illustration), also 50 other different stamps, China ship set, large \$1.00 U. S. revenue; millimetre scale, ruler and perforation gauge. Bargain lists and 50 to 60% approvals with every order. **FENNELL STAMP CO.** **9c**  
Dept. S. Fullerton Bldg., St. Louis, Mo.

**SUDDEN SERVICE**

**STAMPS** 50 different Jamaica, Venezuela, etc., only 7c; 100 all different, 10c; 1000 all different, \$2.50; 100 different U. S. 25c; 1000 hinges, 10c; 50% approvals with every order. List Free. 1 buy stamps.

**L. B. DOVER** Dept. F. Longmont, Colo.

**BARGAINS** EACH SET 5 CENTS  
4 Iceland; 8 Finland; 20 Sweden; 8 Honduras; 8 Costa Rica; 10 Russia; 8 Dutch Indies; 4 Siam. Lists of 7000 low-priced stamps free.  
**CHAMBERS STAMP CO., 111 G NASSAU STREET, NEW YORK CITY**

**FREE** 10 Scandinavian, millimetre scale, gauge, book, lists, etc., to all sending 10c for 57 diff. Siam, Ceylon, Guatemala, etc., 200 diff. 25c, 300 diff. 75c., 100 diff. U. S. 25c.  
**HAWKEYE STAMP Co., Cedar Rapids, 49, Iowa.**

**SURPLUS STOCK** old U. S. Stamps, including many rarities, for sale at bargain prices. Send for price list.  
**P. R. ANDREWS, Sanford, Fla.**

**FREE** 20 Diff. British Colonies for a request for my 1, 2, 1 and 2c approvals also the higher priced stamps at 50% Discet. with extra Disets. for prompt returns.  
**CHARLES T. EGNER, 1335 Pike St., Philadelphia, Pa.**

**STAMPS—20 VARIETIES, UNUSED, FREE** to all sending for our approval sheets at 50% discount. Postage 2 cents. Mention *St. Nicholas*. **QUAKER STAMP CO., TOLEDO, OHIO.**

**FREE** 2 GERMAN AEROPLANE STAMPS to approval applicants. Reference required.  
**J. R. NICHOLS, 2322 Loring Pl., New York City.**

**DANDY PACKET STAMPS** free for name, address 3 collectors, 2c postage, with 50% apprs. 125 dif. U. S. inc. high values, 50c. U. T. K. **STAMP CO., UTICA, N. Y.**

**Stamps Free** Fine set War Stamps, Surcharged, Unused, Pictorials, British, French Col's with Big Price List, 2c postage. **MIDLAND STAMP CO., Toronto, Canada.**

**FREE** Packet of fine stamps for names and addresses 2 live collectors, and 2 cents postage.  
**HIAWATHA STAMP SHOP, Syracuse, N. Y.**

**Approval Sheets:** 50% Discount. Sent anywhere *St. Nicholas* goes.  
**FREDERICK B. DRIVER, Doylestown, Pa.**

**50c** in stamps free with order. Austria, 14 var., 10c; Canada, 8 var., 12c; Japan, 40 var., 12c.  
**FRED SEYFFARTH, 435 Ralph St., BROOKLYN, N. Y.**

**WORLD'S LARGEST** Wholesale and Retail Catalogue of Postage Stamps now ready. 128 pages. Single stamps, sets, packets, albums, mixtures, supplies, etc.  
**Price 10 cents. Worth \$5 to you. Send 10 cents today.** We offer these great bargains at low prices. No two stamps alike in any set. All fine. 50 Africa 24c; 15 Arg. Rep. 11c; 50 Asia 17c; 35 Austria 10c; 35 Bavaria 20c; 10 Brazil 5c; 100 Br. Col's 29c; 25 Bulgaria 25c; 20 Chile 11c; 10 China 7c; 50 Cuba 49c; 10 Czecho's 12c; 10 Egypt 7c; 7 Iceland 20c; 50 Italy 19c; 40 Japan 7c; 8 Liberia 25c; 17 Mexico 10c; 13 Nyassa 45c; 10 Paraguay 10c; 25 Persia 25c; 6 Reunion 5c; 20 Russia 10c; 7 Siam 15c; 10 Straits 7c; 30 Sweden 11c; 100 U. S. 20c; 10 Uruguay 8c; 50 French Col's 34c; 50 Portuguese Col's 35c. Following wonderful collections guaranteed to satisfy or your money back: 1000 varieties \$2.90; 1500 varieties \$5.45; 2000 varieties \$8.90. Postage extra. Remit in stamps or money order. We buy stamps. **MARKS STAMP CO., Dep't N, TORONTO, CANADA.**

**75 STAMPS.** Each from a different country —only 50c—send for packet No. 248. 100, all different, from Africa—only, \$1.00, packet No. 223. Send for free price list—thousands of stamp bargains.

**SCOTT STAMP AND COIN CO.**  
33 West 44th Street New York City



**65c for 8c.** Abyssinian stamp, Guatemala Parrot stamp, Packet 30 varieties British Colonies, cat. 65c. Packet Hinges. Large mm. scale, perf. gauge and wmk. detector. Price list and finest 50% approvals all for 8c. **WE BUY STAMPS.**

**ALLEN SEARS, Inc.**

Dept. S, Suite 508 Kemper Bldg., Kansas City, Missouri.



**158 Genuine Foreign Stamps**

Mexico War issues, Venezuela, Salvador and India Service, Guatemala, China, etc. Only 10c **Finest Approval Sheets 50 to 60%.** Agents Wanted. Big 72-page Lists **Free.** We buy Stamps. Estab. 29 yrs. **Hussman Stamp Co., Dept. 52, St. Louis, Mo.**

**QUICK SERVICE!** When you want stamps you want 'em quick. And I have just the kind you want; clean, well arranged, up to date approval selections at 50% disc. with extra discounts for prompt returns. The general collector will be delighted. Try them and you will say "How does he do it?"  
**D. M. WARD, 608 Buchanan St., Gary, Ind.**  
P. S. 3 Aguinaldo Philippine Stamps free to approval applicants.

**SNAPS** 150 different foreign, 18c. 60 different U. S. including \$1 and \$2 revenues, for 12c. With each order we give free our pamphlet which tells "How to Make a Collection Properly." **QUEEN CITY STAMP AND COIN CO., Room 32, 604 Race St., Cincinnati, O.**

Stamps 50 all dif., Africa, Brazil, Peru, Cuba, Mexico, Ceylon, Java, etc., and Album, 10c. 1000 **Finely Mixed, 40c.** 50 dif. U. S., 25c. 1000 hinges, 10c. Agts. wtd., 50%. **List Free.** I buy stamps. **C. Stegman, 5940 Cote Brillante Ave., St. Louis, Mo.**



(Continued on next page)



## ST. NICHOLAS STAMP PAGE

(Concluded from second preceding page)

### STAMPS—(Continued from preceding page)

**FOREIGN STAMPS FREE**—Big Variety Packet Foreign Stamps from all over the World. 2c postage.  
GRAY STAMP Co., Station E., Toronto, Canada.

**25** Gold Coast, Newfoundland, India, etc., FREE with trial approval sheets. 500 different stamps 90c; 1000 all different \$2.25. Hinges 10c per M. F. J. STANTON, Norwich, N. Y.

**ALL FOR 10c** 20 STAMPS FROM 20 COUNTRIES, 10 unused and 2 Malay (Tigers).  
**FOYE STAMP COMPANY** Detroit, Michigan

**FRENCH COLONIES FREE**—Set Used and Unused Pictures, Wild Animals, Native Chiefs, Scenery and big bargain List. 2c postage. EMPIRE STAMP Co., Toronto, Canada.

**STAMPS** 105 China, etc., stamp dictionary, list 3000 bargains, 2c. Album (500 pictures), 3c, BULLARD & Co., Sta. A, BOSTON.

Genuine U. S. and Foreign Stamps on approval at 50% discount.  
HUB POSTAGE STAMP Co., INC., 45 Bromfield St., Boston, Mass.

**FREE** 7 beautiful French Colonials, to approval applicants. FRANK HADLEY, BOX 73, Plainfield, N. J.

**200** diff. Stamps 18c; 100, 9c. 20 Persia 20c, Hinges 1000, 12c. Lists Free. MICHAELS, 5602 Prairie, Chicago.

**1500** different stamps \$5; 1000, \$2.50; 550, \$1; 300, \$45; 200, \$20; 100, \$10. F. L. ONKEN, 630 79th St., Brooklyn, N. Y.

**DOMINICA** WARS. ½d. 1½d. Cat. 25c. Net 8c.  
A. C. DOUGLAS, A.S.D.A., Lucan, Ont.

**4** different Morocco, Cat. 32c, for **14c**  
R. H. A. GREEN, 821 Main St., Evanston, Ill.

**10 STAMPS FREE WITH TRIAL APPROVALS**  
(Cat. 20c) F. E. THORP, Norwich, N. Y.

**FREE**—Scarce Abyssinian Stamp with your first application for approvals. Get yours before they are gone.  
IROQUOIS STAMP SHOP, 704 Keith Theatre Bldg., Syracuse, N. Y.

**FREE** 40 stamps from Australia, Portugal, Union of South Africa, etc., to applicants for our fine approvals.  
JOHN L. WILLETT, 2101 E. 89th Street, Cleveland, Ohio.

**FREE**—Packet containing Cyprus, etc., to app. applicants. Send names of 2 collectors. FRANK H. EWING, 2096 E. 89 St., Cleveland, O.

**Penny mint Approvals** Mint stamps, one cent each.  
THEODORE H. AMES, Bradley Beach, N. J.

### Have You Joined the Throng of Young Stamp Savers?

If not you are missing the opportunity of having a lot of fun, as well as the chance of learning a lot of valuable things about the different countries of the world. You will find that you will pick up information that will help you in your study of geography and history, and it won't be like studying at all.

Then, too, stamp collecting develops the powers of observation, and trains one in accurate and careful thinking.

It's easy to start. Just drop a line to one of the stamp dealers advertised here, and he will be glad to send you catalogues, approval sheets, etc.

represents the battle of Shipka Pass. ¶Perhaps no stamps bother the beginner so much as those of Hungary. If only all our readers could know (or remember) that the word "Magyar" means Hungary, it would save them a deal of trouble. One little lad sends us a stamp of the 1902 issue "with a bird and a crown upon it," and wants it identified. It too is from Hungary. The fierce, hawklike bird is the fabled "Turul," and the crown is the famous crown of St. Stephen. Notice that the little button or ornament at the top does not stand upright, but is tipped to one side. It is interesting reading to hunt up in the Encyclopedia the story of St. Stephen, and of this crown of his. ¶Girls collect stamps as well as boys, and they ask questions, too. One of them asks us what we think is the most beautiful stamp ever issued. That is so much a matter of taste that no doubt many would disagree with us. Indeed, some years ago we held a "Contest" on this very point, and no two answers gave the same stamp. Personally, we think that the twelve-cent Newfoundland (Scott's No. 27) is entitled to the honor. Recently, a competition was held in France to see what the opinion was there. The largest number of votes was for Belgium No. 1. Alas for our idea of beauty!—the Newfoundland stamp was nowhere near the top, if indeed it was voted for at all. ¶One of our readers is trying to learn all that he can about such trees as appear upon stamps. He calls our attention to the design on the first stamp of Nicaragua. Here are a series of mountain-peaks, on one of which is a pole or liberty-cap, while on another peak is a tree. Can any one tell us why the tree? Is it just a tree indigenous to Nicaragua, or perhaps something in the nature of an emblem? Or perhaps some specific tree associated with the history of Nicaragua—something similar to the "Charter Oak" of Connecticut? We should be glad for any information that can be given us.

\$32,000

THE sale of a British Guiana stamp for the record price of \$32,000 has attracted much attention not only within the sacred circle of stamp-collectors, but in the outer world as well. The daily press has commented upon this sale again and again. As many of our readers have written to us for a definite description of the stamp, we publish in Stamp Page a pen drawing of it from the Standard Stamp Catalogue, though those of our readers who own a copy of this book have doubtless already looked up the illustration there. These stamps were all initialed by some one in the post-office before they were sold. The curious scroll work at the left is this initialing—E. T. E. D.

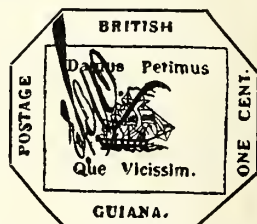

of it from the Standard Stamp Catalogue, though those of our readers who own a copy of this book have doubtless already looked up the illustration there. These stamps were all initialed by some one in the post-office before they were sold. The curious scroll work at the left is this initialing—E. T. E. D.

*The Philosopher-Vagabond Sees South America*

---



## WORKING NORTH FROM PATAGONIA

By **HARRY A. FRANCK**

*Author of "A Vagabond Journey Around the World," etc.*

**T**HE enormous continent of South America is traversed by Mr. Franck from its extreme south to its northeast corner — from Argentina to Venezuela. He sees the Rio de la Plata and the "turbid Amazon"; the pampas and the "Paris of the South," Buenos Aires; ancient Chile; the upstanding, progressive little republic of Uruguay; Rio, great Brazil, the Guianas and Venezuela.

This is an important and a fascinating addition to Mr. Franck's remarkable group of travel books. They are always welcomed, always popular, but the growing appreciation of the importance to us of understanding South America makes this one even more than usually timely and acceptable. Together with his "Vagabonding Down the Andes," it constitutes a complete picture of South America, physical, social, economic and political. The book has 650 pages and 176 illustrations from photographs taken on the journey by the author himself.

*Price \$5.00*

*By the Same Author*

## VAGABONDING DOWN THE ANDES

**T**HE companion volume to Mr. Franck's "Working North From Patagonia." In this book he tells of his adventures in the land of the Incas as he worked his way along and over the snow-clad Andes. He covers Colombia, Ecuador, Peru, Bolivia, etc.

*Profusely illustrated from photographs. Price \$5.00*

## ROAMING THROUGH THE WEST INDIES

**O**NE of the most delightful books Mr. Franck has written. He makes the reader know Cuba, Porto Rico, the Virgin Islands, Barbados, Santo Domingo, Haiti, Dominica, Jamaica, and many another memorable island asleep in the Caribbean.

*Charmingly and richly illustrated from photographs. Price \$5.00*

---

At All Bookstores  
Published by

**THE CENTURY CO.**

353 Fourth Avenue  
New York City



## The First Book Ever Done On The Laurentians

**T**HIS mysterious wonderland of the North, only thirty-six hours from New York City, is as foreign as France and as wild as in the days of Jacques Cartier and offers interests of infinite variety.



# THE LAURENTIANS

By T. M. LONGSTRETH

A DELIGHTFUL combination of travel, adventure and guide-book. It taps a new and inexhaustible land either for the tourist who would merely voyage in comfort up the Saguenay, for the canoeist on the lookout for new routes, for the well-read who have romance in their veins and cannot afford a trip to Normandy, or for the man who does not care to read and yet wants information on new hunting lands. It is preëminently for the person who, whether he is to visit foreign lands or not, likes to read about them and about the author's adventures in them.

Mr. Longstreth spent some time with the Chapdelaine family which appears in Louis Hemon's famous novel, "Maria Chapdelaine."

*Illustrated. Price \$3.50*

Also By Mr. Longstreth

## THE CATSKILLS

**F**OLLOWING his popular method, the author has produced another of his delightful and useful combinations of travel and guide books on that mountain playground nearest New York City, the Catskills. This is the region that John Burroughs loved so loyally and whose praises he sang for so many years. It is the land of Rip Van Winkle, the recreation ground for innumerable vacationists.

*Illustrated. Price \$3.50*

## THE ADIRONDACKS

**T**AKING with him a congenial companion, Mr. Longstreth wandered over the great Adirondack country; and his book is a charming record in the mood of Stevenson of the adventures of two travelers in that vast natural park. Incidentally, he gives all manner of information about roads, hotels, clubs, etc. In this, as in all his books, the author brings to the reader the very feel of the great out-of-doors.

*Illustrated. Price \$3.50*

At All Bookstores  
Published by

**THE CENTURY CO.**

353 Fourth Avenue  
New York City

# “I’m Coming!”

It was a boy who said it as he let the flood force his shanty-boat through the jam to save the two lads on the wreckage; but it was a man in supremely tested courage and firm nerve who came out of the tremendous experiences told in



## DRIFTWOOD

By R. S. Spears

THE BEST STORY OF THE MISSISSIPPI SINCE

### “Huckleberry Finn”

A story for boys and girls of the Mississippi in flood. Full of thrilling adventure and plucky, resourceful, level-headed work of rescue. There is in it something that makes grown-up readers, too, appreciate and praise the book. It is a vivid picture of the river life and river-folk. And behind all the tense, exciting action is a movement that lifts it far above the average, that makes it at the same time an adventure story of the finest and an epic of mighty waters in irresistible flood. A remarkable juvenile; a notable American book; a book to own.

*Illustrated. Price \$2.00*

I  
WANT

.....copies of

## DRIFTWOOD

for which I enclose \$.....

**THE CENTURY CO.**

353 Fourth Avenue

NEW YORK CITY

Name.....

Address.....





“AD”  
VENTURES of the

# IVORY HEROES



HERE was a naughty Comet once that wouldn't mind his mother, nor run in parabolic curves politely like his brother. But through the starry meadows he bumped friend and foe alike, until the solar system was about to go on strike. He thumped the stars, smoked up the moon with flaming, fiery tail; destruction spread behind him in a musty, murky trail.



Comets, fish, or fowl were all alike to him. He roped that saucy Comet and he hitched him to the moon, and all the force of IVORY might was turned upon him soon. They hosed him and they scrubbed him, and they covered him with lather made out of all the IVORY cakes that Yow and Snip could gather. The reason for that Comet's way of knocking things about was that his eyes were full of dust that he could not get out.

But when his shining face was washed he blinked with radiant joy, and said he now could be as good as any Comet boy. He'd travel in an orbit and he'd visit Mr. Sun once every thousand years, just as he always should have done. Our heroes started Comet out upon his proper track and promised that they'd be on hand the day he wandered back.

*And Gnif replied, "Our IVORY  
Is good for all commissions,  
From cleansing houses made of glass  
To naughty dispositions."*

Our IVORY heroes heard about this reckless sky marauder, and vowed they would reform him, e'er the woe was any broader. Around and 'round the heavens went that busy IVORY bubble until it spied the cause of all that smoking, bumping trouble.

You will recall how Gnif lassoed the Thrasher, fierce and grim; and tails of

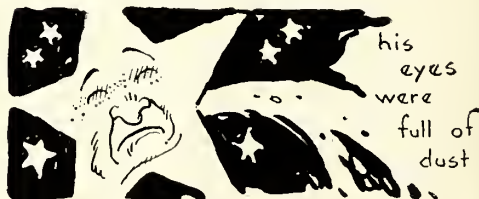

Don't you want to see how and when these marvelous adventures began? Then write to your friends, The Procter & Gamble Co., Cincinnati, Ohio, asking for a little book called "THE CRUISE OF THE IVORY SHIP," by John Martin. It is a wonderful little bedtime book, given FREE to you.



**IVORY**  
IT FLOATS



**SOAP**  
99 <sup>44</sup>/<sub>100</sub> % PURE





## “WASH”— Don't Scour Teeth!

You would not clean piano keys  
With any gritty, sandy stuff,  
For that would leave the ivories  
All full of scratchy lines, and rough.

Your teeth deserve more than the care  
Piano keys receive, by far;  
When brushing teeth you should beware  
Of gritty pastes that scratch and mar.

Use Colgate's Ribbon Dental Cream  
To clean your teeth the proper way;  
It makes the smooth enamel gleam,  
And is the best, the dentists say.

“Good Teeth—Good Health!” Let that come true  
For every girl and every boy;  
Use Colgate's night and morning, too,  
It has a flavor you'll enjoy.

Cut out the fourth stanza, mail  
it to us, with your name and  
address, and we will send you,  
free, a generous trial tube of  
Colgate's Ribbon Dental Cream.

**COLGATE & CO.**

Dept. 60

199 Fulton Street, New York



Colgate's cleans teeth thor-  
oughly—no dentifrice does  
more. A LARGE tube  
costs 25c—why pay more?





**PEP-O-MINT**  
**LIFE SAVERS**  
THE CANDY PRESERVED BY THE MOLE

MARY HAD A LITTLE LAMB  
WITH ONIONS IN HER STEW  
LIFE SAVERS TOOK HER  
BREATH AWAY  
SO SHE COULD  
BILL AND COO!

Pop-O-mint

Wint-O-green

Lic-O-ribe

Cl-O-ve

Cinn-O-mon



# ST. NICHOLAS



THE CENTURY CO

353 FOURTH AVENUE NEW YORK

THE CENTURY AND ST. NICHOLAS

HAROLD SICHEP



# Old As the Pyramids



WHEN you read in your history about the Pyramids and the Sphinx they seem older than anything else in the world. But the palm and olive oils, which are blended in Palmolive Soap you use each day, were discovered in these same days in ancient Egypt.

Of course the crude combination which satisfied these old-world users is far different from the fragrant, green cake which equips washstands in millions of American homes today. It possesses the same soothing, softening, beneficial qualities which have made these oils famous for centuries as cleansers and cosmetics.

Another great difference is the difference in cost. In the old Egyptian days these oils were

scarce and high-priced and only available for the favored few. Now they are imported in vast quantities, while the Palmolive factories work day and night to supply the demand. This puts Palmolive within the reach of all.

If you will send us your name and address on a postal card we will send you a miniature cake of Palmolive Soap, wrapped and labeled just like the big cake, together with an interesting book on how Palmolive is made. Address Dept. B-344.

THE PALMOLIVE COMPANY, Milwaukee, U. S. A.  
THE PALMOLIVE COMPANY OF CANADA, Limited  
Toronto, Canada

*Also makers of Palmolive Shampoo and Palmolive Shaving Cream*



# Beech-Nut Peanut Butter

*“More Foods of  
Finest Flavor”*

Bacon  
Beef  
Peanut Butter  
Macaroni  
Spaghetti  
Macaroni Elbows  
Macaroni Rings  
Vermicelli  
Pork and Beans  
Tomato Catsup  
Chili Sauce  
Prepared Mustard  
Jams and Jellies  
Marmalades  
and Preserves  
Ginger Ale

## CONFECTIONS

Mints  
Cloves  
Wintergreens  
Licorice  
Sweet Birches  
Cinnamons  
Menthols  
Fruit Drops  
Caramels  
Peanut Bars  
CHEWING GUM



**A**FTER a feller has had *just one taste* of Beech-Nut Peanut Butter he'll want it over and over again. Spread it thick on bread—one slice won't be enough. And it's *good* for you, too! That's because it's Beech-Nut, and you can depend on the quality. Comes in glass jars—always fresh and pure. Just the thing after a long hike or a skating party. Always ready to serve. Needs no preparation. Most grocers have it.



**BEECH-NUT PACKING COMPANY**  
CANAJOHARIE NEW YORK



# CONTENTS OF ST. NICHOLAS FOR OCTOBER, 1922

**Frontispiece: "He was marooned in Crater Lake!"** Drawn by Donald Teague

**Marooned in Crater Lake.** Story. Illustrated by Donald Teague, and from a photograph. Alfred Powers..... 1235

**The Workshop of the Mind. VII.** Hallam Hawksworth ..... 1243

Illustrated by Harold Sichel and from painting by Robert A. Hillingford

**Of Course You Would!** Verse. Illustrated by Reginald Birch..... Arthur Guiterman..... 1251

**Indian Summer.** Picture. From painting by Charles C. Curran..... 1252

**The Ride to Orchard.** Story. Illustrated by George Varian..... L. Dean-Hatch..... 1253

**Evening.** Verse..... Barbara Poole..... 1257

**The Mystery at Number Six.** Serial Story. Illustrated by W. P. Couse... Augusta Hulell Seaman 1258

**The Oldest Printing Establishment in Existence.** Sketch..... Harry Tuck Sherman... 1266

Illustrated by Joseph Pennell, and from a photograph

**The Princess Alone.** Story. Illustrated by Dorothy Hlope Smith..... Sherlock Bronson Gass... 1272

**The "Eagle" and the "Hen."** Story. Illustrated by C. M. Relyea..... Arthur W. Peach..... 1281

**Felicia Explains — Finally.** Story. Illustrated by Donald Teague..... Margaret T. Macdonald. 1285

**Trapped by the Red Terror.** Story. Illustrated by Enos B. Comstock... Wallace Hutchinson... 1292

**The Turner Twins.** Serial Story. (Conclusion). Illustrated by C. M. Relyea. Ralph Henry Barbour .. 1296

**The Forest Troubadour.** Verse. Illustrated by the author..... Henry C. Pitz..... 1302

**Planting Your Apple-seed**..... Hildegard Hawthorne... 1304

**Sir Cyril's Winning Shot.** Verse. Illustrated by the author..... Charles F. Lester..... 1306

**The Cone Gatherers.** Sketch. Illustrations from photographs..... Ethel Claire Brill..... 1308

**Golf for Boys and Girls.** Sketch. Illustration from a photograph..... Cecil Leitch..... 1313

**The Battle of the Trees.** Verse..... Edith De Blois Lasley... 1314

**The Inca Emerald.** Serial Story..... Samuel Scoville, Jr... 1315

Illustrated by Charles Livingston Bull

**The Merry-Go-Round.** Verse..... Mabel Livingstone..... 1321

**An Apt Scholar.** Verse..... Ellen Manly..... 1321

**The Watch Tower.** A Review of Current Events. Illustrated..... Edward N. Teall..... 1322

**Nature and Science for Young Folk.** Illustrated..... 1327

Trapping Insects by the Lure of Light (M. Tevis) — Why Leaves Fall (Mark Meredith) — A Deadly Parasite (S. Leonard Bastin) — A Mooring-Mast for Airships (George F. Paul) — The Petrified Forest on the Mountain-top (Bronte A. Reynolds)

**For Very Little Folk: The House that Peter Built**..... Nina Hatchitt Duffield... 1332

Illustrated by Marion T. Justice

**The St. Nicholas League.** With Awards of Prizes for Stories, Poems, Drawings, Photographs, and Puzzles. Illustrated..... 1334

**The Letter-Box**..... 1342

**The Riddle-Box**..... 1343

**St. Nicholas Stamp Page.** Conducted by Samuel R. Simmons..... Advertising Pages

 *The Century Co. and its editors receive manuscripts and art material, submitted for publication, only on the understanding that they shall not be responsible for loss or injury thereto while in their possession or in transit. Copies of manuscripts should be retained by the authors.*

In the United States, the price of **ST. NICHOLAS MAGAZINE** is \$4.00 a year in advance, or 35 cents a single copy; the price of a yearly subscription to a Canadian address is \$4.35. The price of a yearly subscription to a foreign address is \$4.60. We request that remittances be by money-order, bank check, draft, or registered letter. The Century Co. reserves the right to suspend any subscription taken contrary to its selling terms, and to refund the unexpired credit. PUBLISHED MONTHLY.

The half-yearly parts of **ST. NICHOLAS** end with the October and April numbers respectively, and the red cloth covers are ready with the issue of these numbers; price \$1.00 by mail, postpaid; the two covers for the complete volume, \$2.00. We bind and furnish covers for \$2.00 per part, or \$4.00 for the complete volume. (Carriage extra.) All copies of this magazine which are to be bound must be sent to our New York office. In sending the numbers to us, they should be distinctly marked with owner's name. Bound volumes are not exchanged for numbers.

All subscriptions for, and all business matters in connection with, **ST. NICHOLAS MAGAZINE** should be addressed to

### THE CENTURY CO.

Publication and Circulation Office, Concord, N. H.

Editorial and Advertising Offices, 353 Fourth Ave., New York, N. Y.

W. MORGAN SHUSTER, *President*  
DON M. PARKER, *Secretary*

GEORGE L. WHELOCK, *Treasurer*  
JAMES ABBOTT, *Ass't Treasurer*

### BOARD OF TRUSTEES

VOL. XLIX.

GEORGE INNESS, JR.

GEORGE H. HAZEN, *Chairman*

W. MORGAN SHUSTER

No. 12

(Copyright, 1922, by The Century Co.)

(Title Registered U. S. Pat. Off.)

(Printed in U. S. A., and Entered as Second Class Matter, September 4, 1920, at the United States Post Office, Concord, N. H., under the Act of March 3, 1879. Entered at the Post Office Department, Ottawa, Canada.)

SO MANY WONDERFUL GAMES BEING MADE, BE SURE YOU DO NOT MISS ANY



# GAMES

THAT CHILDREN LOVE TO PLAY

HERE is a collection of games of the many which the Milton Bradley Company design to make any little boy or any big boy happy. (We know one big boy whose hair is gray at the temples, and who has to wear "specs" to see, who confesses without shame he has never ceased to enjoy playing these children's games and hopes he never will.)

**Pirate and Traveler** is one travel game that comes in a big box. A well-made game, beautifully colored, giving a realistic chart of the world with pictures of the people and animals of each country. To play it, a spinner gives you your destination and you learn how to travel to the Orient, to India and Alaska, and the adventures on the way are full of thrills.

**Uncle Wiggily** Another big box full of fun. A game by Howard Garis, author of the Uncle Wiggily bedtime stories. Delights children because they can seem to actually live in these favorite stories of theirs.

**Spoof** A most unique card game, about which, the story goes, there is a legend connecting it with the ancient Incas of Peru who called a man a spoof who could not collect certain worldly possessions.

**Rumme** A card game with ten varieties of play which gives the child ten games in one.

**Logomachy** An old favorite that will never lose its popularity. This is the play way of spelling, and children of all ages delight in putting their new-found knowledge of spelling to some practical use.

*Bradley games are on sale at Novelty, Toy, Department and Stationery Stores everywhere  
Look for the Bradley Games Counter*

**MILTON BRADLEY CO.**

*Makers of the World's Best Games Springfield, Mass.*



# Bradley's

THE WORLD'S BEST  
GAMES





## "A Continental Dollar"

**S**T. NICHOLAS will begin in November a new serial story by Emilie Benson Knipe and Alden Arthur Knipe, carrying the above title.

ST. NICHOLAS readers need no particular introduction to these authors, for they have been writing serials for the magazine at intervals since 1912, when their first story, "The Lucky Sixpence," was published. That was followed by "Beatrice of Denewood," "Peg of the Ring," "Vive la France!" and "The Luck of Denewood," which was published in ST. NICHOLAS during 1921.

In "A Continental Dollar" we leave Denewood along the side-lines, so to speak, and follow the fortunes of Patty Abbott and her soldier brother Val. And an active pair they are! Trying times and narrow escapes keep you on edge for the next instalment, and there 's a secret message to be translated and a treasure to be found, as well.

Don't handicap yourself by allowing your subscription to expire *now*. Begin with the first paragraph of this interesting serial, and follow it to the end. You 'll agree that this one Continental Dollar is worth four of our present ones. And, in addition, you 'll get twelve numbers full of other stories and articles — 112 pages each month crammed with good things.

*Begin with the first number of volume fifty by sending the attached blank and four dollars to-day to The Century Co.*

THE CENTURY CO. { Concord, N. H., or  
353 Fourth Avenue, New York City:

S.N. 10-22

Gentlemen: Please find enclosed \$4, for which send ST. NICHOLAS for one year, beginning with the November number, to

Name..... Street.....

City..... State.....



# GOOD SCHOOLS

FOR

## BOYS *and* GIRLS

### Miss Hall's

SCHOOL FOR GIRLS

In the Berkshire Hills, on the Holmes Road to Lenox. Forty-five acres. One thousand feet above the sea level.

Miss MIRA H. HALL, Principal  
Pittsfield, Massachusetts

### PAGE MILITARY ACADEMY



A big school for little boys (as young as six but not over fourteen) where the little fellows get home care and training. Your boy will be safe here while he learns worth-while things. Sympathetic, intelligent guidance everywhere. Military training, modified to meet boys' needs, makes alert, erect and prompt. Let Page start your boy so he will go right. Lady teachers to fifth grade. House Mothers. Ask for the Page catalog. Address

ROBERT A. GIBBS, Headmaster  
Route 7, Box 947  
LOS ANGELES CALIFORNIA

NEW YORK, New York City.

### COLUMBIA PREPARATORY SCHOOL

301 West 88th Street at West End Avenue, New York  
Resident and Day. Boys and Girls. Kindergarten—Grammar—College Preparatory. For catalog address  
DR. S. N. CLAWSON, Principal.

MASSACHUSETTS, Bradford.

**JUNIOR BRADFORD** A preparatory school for Bradford Academy.  
Directed study and play. Arts and crafts. All advantages of Bradford Academy equipment. For Booklets, address THE "PRINCIPAL,"  
139 Main Street, Bradford, Mass.

RHODE ISLAND, Providence.

**LINCOLN SCHOOL** A school for girls, offering country life with the advantages of the city. Special preparation for college examinations and general courses. Exceptional opportunity for outdoor sports. Horseback riding.  
MISS MIRIAM SEWALL CONVERSE, Principal,  
Providence, Rhode Island.

CONNECTICUT, New Canaan.

**STAMFORD MILITARY ACADEMY**  
Thorough scholastic and military training fostering the intellectual, physical and moral needs of developing boys. Personal instruction. Small classes. Manly sports encouraged. Extensive equipment. Ideally located in the Connecticut hills. Summer Camp.  
WALTER D. GERKEN, A.M., Principal, New Canaan, Conn.

NEW YORK, Tarrytown-on-Hudson, "The Castle."

**MISS C. E. MASON'S** Suburban School for Girls  
Only 40 minutes from N.Y. City. Upper School for girls 13 to 25; Lower School for girls 6 to 13. All departments. Vocational training emphasized in Summer School. Preparation for leading colleges. For circular address Miss C. E. MASON, LL.M., Lock Box 725.

MASSACHUSETTS, Worcester.

**WORCESTER ACADEMY**  
250 Boys. 22 Teachers. Strictly preparatory for college and engineering school. Junior School for young boys. For catalog, address The Registrar, G. D. Church, M. A.  
SAMUEL F. HOLMES, M.A., Principal, Worcester, Mass.

CONNECTICUT, Cornwall.

**RUMSEY HALL**  
A School for Boys under 15. Yearly rate \$1300.  
L. R. SANFORD, Principal.  
LOUIS H. SCHUTTE, M.A., Headmaster.

RHODE ISLAND, Providence.

**THE MARY C. WHEELER SCHOOL**  
A Town and Country School for Girls  
College preparatory and General Course. Advanced Studio classes. Music. Secretarial Course. Farm Home for girls 10 to 14 years.

# Whiting Hall

## A Country Home School for Girls

from eight to sixteen, affiliated with the best preparatory schools. Twenty-six acres, modern buildings, new gymnasium, ideal location, high elevation—halfway between Boston and Worcester, near Longfellow's Wayside Inn. Outdoor sleeping and class rooms, if desired. Individual care. Teachers for all branches. Mistress of field games. House mother. Family life emphasized. Tenth year.  
MR. ELBRIDGE C. WHITING, Amherst, Yale, MRS. WHITING, Wellesley, Prins. CONCORD ROAD, SOUTH SUDBURY, MASS.



## WOODLAND PARK Junior School of Lasell Seminary

Prepares for Lasell Seminary and other leading secondary schools. Careful direction under House Mother. Progressive methods of study and play. All the equipment of Lasell Seminary, with playgrounds, gymnasium and swimming pool. 15 Buildings. 30 Acres.

Camp Teconnet opens July 1st

Guy M. Winslow, Ph.D., Principal Chas. F. Towne, A.M., Associate Principal  
10 Woodland Road, Auburndale, Mass.



MASSACHUSETTS, Norton.

**THE HEDGES** The Junior School of House in the Pines. Norton, Mass., 30 miles from Boston. For girls under fourteen. A wholesome, simple life of study and play that shall make the child quick to feel, eager to know, able to do.

MISS GERTRUDE E. CORNISH, *Principal*.

NEW YORK, Long Island Sound.

## SOUTHFIELD POINT HALL

A school for girls. Beautifully located on Long Island Sound. Intermediate, General and College Preparatory Courses. Music, Gymnastics, Athletics and Sports. Address JESSIE CALLAM GRAY, B.A. *Principal*, 10 Davenport Drive, Stamford, Conn.

MASSACHUSETTS, Northampton.

## WILLISTON JUNIOR SCHOOL

For Young Boys. Organized to develop the entire boy. Thorough work and graded athletics. The Senior School prepares for all leading colleges and scientific schools.

ARCHIBALD V. GALBRAITH, *Principal*, Box N, Easthampton, Mass.

MASSACHUSETTS, Berkshire.

**CRESTALBAN** A school for little girls in the invigorating climate of the Berkshires. Thirty minutes from Pittsfield. 200 acres, 3 buildings. Number limited. Special care given to home training, character development, and health. Open-air classes. Outdoor sports.  
MISS MARGERY WHITING, *Principal*.

## Summer Camps



## For Girls (under 20 years), Roxbury, Vermont

A 300-acre wonderland in the heart of the Green Mountains. Athletic fields, private swimming pond, clay tennis courts, screened dining porch, sleeping huts, and a big assembly hall for plays, dances, music, and games around a big cheery fireplace. Famous for its fine saddle horses, free horseback riding, instruction, and wonderful camping trips. Separate camps for Juniors and Seniors. Enthusiastic counselors carefully chosen. Write now for illustrated booklet.

Mr. & Mrs. C. A. Roys, 10 Bowdoin St., Cambridge, Mass.

PENNSYLVANIA, Swarthmore.

## THE MARY LYON SCHOOL

A Country School in a College Town Preparatory for college. High scholastic standards. Music, Art, Languages, Home-making Sciences. Outdoor sports including canoeing. SEVEN GABLES—Junior School, WILDCLIFF—Graduate School. Write for catalogs.  
MR. and Mrs. H. M. CRIST, *Principals*, Box 1542, Swarthmore, Pa.

MARYLAND, Catonsville.

## THE ROBERTS-BEACH SCHOOL

Limited number of girls, individual instruction. Strong college preparatory and general course. Outdoor life on ten-acre estate near Baltimore. Rooms with private bath. Box 900, Catonsville, Md.

MASSACHUSETTS, Wellesley.

## TENACRE

A Country School for Girls 10 to 14. Preparatory to Dana Hall, 14 miles from Boston. All sports and athletics supervised and adapted to the age of the pupil. Finest instruction, care and influences.  
MISS HELEN TEMPLE COOKE, Dana Hall, Wellesley, Mass.

## MACKENZIE JUNIOR SCHOOL

ON LAKE WALTON BOYS (6-14)

A Christian School with the home atmosphere. Splendid outdoor life carefully directed. Intimate daily habits closely supervised.  
Monroe, Orange County, New York (1000 ft. elevation)  
CLYDE B. MYERS, *Headmaster*

NEW YORK, Ossining-on-Hudson.

## OSSINING SCHOOL

For Girls. 54th Year. 30 Miles from New York. Academic and economic courses. Separate school for very young girls. For catalog, address  
CLARA C. FULLER, *Principal*, Box 10 N.

## Unclassified

# "STAMMERING Its Cause and Cure"

You can be quickly cured if you stammer. Send 10 cents, coin or stamps, for 288 page cloth bound book on Stammering and Stuttering. It tells how I cured myself after Stammering and Stuttering for 20 years. BENJAMIN N. BOGUE  
186 Bogue Building, 1147 N. Ill. St. Indianapolis





*“Come and see  
a regular pencil!”*

The boy who carries an EVERSHPARP carries his shoulders back and his head high. He has the best pencil made, and is proud of it. Clipped on his pocket, or suspended from a chain, EVERSHPARP says, “Here’s a fellow who is up to date.”

With one load of leads, carried in its magazine, EVERSHPARP can write a book as long as “Robinson Crusoe.” Extra leads, in seven grades, 15c per dozen. Durable materials and accurate workmanship make EVERSHPARP everlasting. Many styles, for girls, too, in gold, silver and enamel. Priced from 50c to \$50. Do not let any one sell you a pencil inferior to EVERSHPARP.

WAHL PEN, with the famous all-metal barrel that holds more ink, matches EVERSHPARP in design and quality. Ask for both by name. Sold everywhere.

Made in U. S. A. by THE WAHL COMPANY, Chicago  
Canadian Factory, THE WAHL COMPANY, LTD., Toronto

**EVERSHARP**

*Write-Hand Companions*

**WAHL PEN**

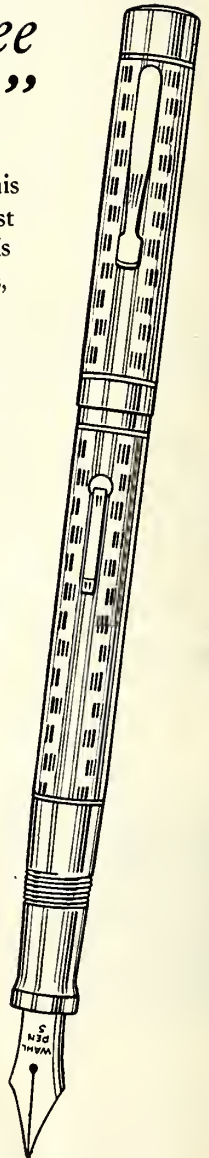





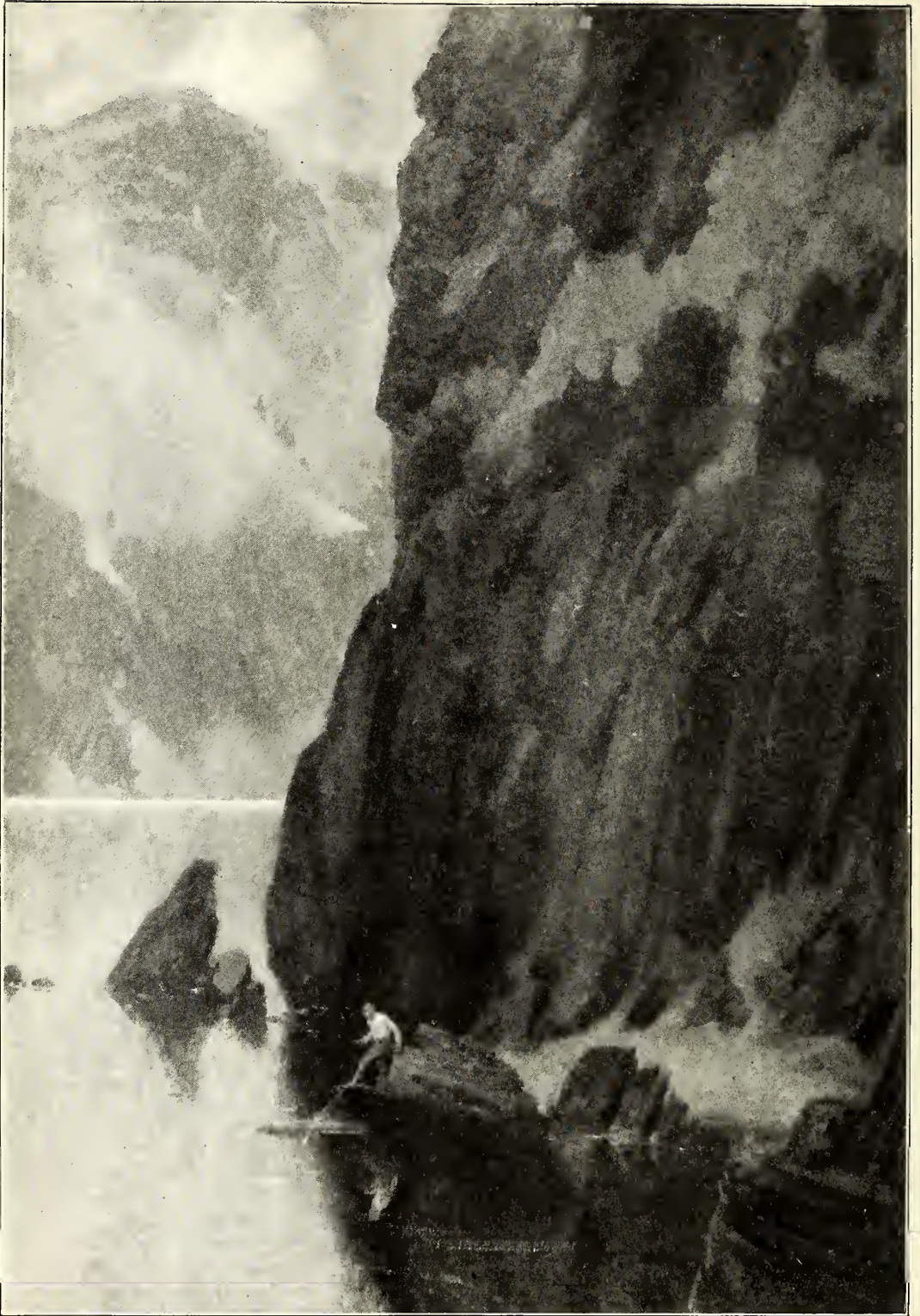

"HE WAS MAROONED IN CRATER LAKE!" (SEE PAGE 1236)

# ST. NICHOLAS

VOL. XLIX

OCTOBER, 1922

No. 12

Copyright, 1922, by THE CENTURY Co. All rights reserved.

## MAROONED IN CRATER LAKE

By ALFRED POWERS

IN October, 1910, before George Washington's profile had displaced the picture of Benjamin Franklin on the one-cent stamps, Jim Turner bought a book of this denomination at Medford, Oregon, securing only twenty-four of the green rectangles for twenty-five cents. But the protective book was well worth a penny when one was traveling and carrying stamps in a warm pocket. He tore out five of the stamps as postage for five scenic post-cards which he mailed, three for his aunt and two for Mrs. Harry Smith. Mailing post-cards was one of his duties as the only boy member of the two-car tourist party which included his uncle and aunt and Mr. and Mrs. Smith. He put the book with its nineteen remaining stamps in a hip pocket of his khaki trousers and promptly forgot all about it until two days later, at the edge of the blue waters of Crater Lake, when he had occasion to use it under circumstances that made those nineteen one-cent stamps of greater value to him than nineteen dollars or even nineteen hundred dollars.

When the man on mule back, who accidentally discovered Crater Lake, cast the first white man's gaze down the precipitous and far descending walls of that deep basin, it was his belief that the unruffled blue water, a thousand feet below, would forever remain inviolate to human touch—it would never slake thirst, or wash dirt from hand or face, or be navigated.

Yet Jim Turner, on that October day in

1910, had done all that the discoverer, seeing no possibility of man's descent down those sheer precipices, thought never would be done. Lying prone, with no cup but the lake itself, he had taken a drink of the cold, satisfying water. He had dipped up in his hat some of it with which to loosen the jelly that clung to his fingers from the sandwiches of his lunch. Finally, that morning at eleven o'clock, he had come in a rowboat to the tiny beach upon which he still stood, dismayed by a universal solitude, menaced by approaching night—deserted, alone!

At six o'clock that October evening he still remained there, the only soul anywhere about the edges of the lake, the unattainable rim itself virtually left unpeopled. The winds that rocked the firs far up on that rim descended to him with abated strength. But the cold crept down, piercing and numbing, so that he had to pace his cramped beach for warmth.

Gathering dusk had already changed the indigo water to black and was blurring the silhouette of Wizard Island out in the lake. The stars brightened and increased. He imagined they were visible to him earlier than to others, as he looked up from the darkening depths of that vast hole in which he stood. Those stars promised that the first snows, due at this season of the year, mercifully would not come that night.

Weather and chance could do with him as they pleased. He could not help himself.



He could not attract the help of others. He was marooned in Crater Lake!

All around, in a grim circle, rose the almost perpendicular walls, from eight hundred to two thousand feet high. In front of him extended the silent and now forsaken waters of the lake, two thousand feet deep. It was impossible to scale the one. It was equally impossible to swim the other.

As he paced up and down on the narrow strip of beach, with darkness closing in around him, Jim had opportunity to review the events that had made him a captive in that majestic prison.

With his uncle and aunt and the Smiths, he had reached Crater Lake on the last day of the season. The Lodge was already closed to guests, and a single caretaker of the property had been left to prepare everything against the approach of winter. Late in the season as it was, a half-dozen automobile parties had come up to look at the lake, for the bad weather, though expected at any time, had not yet set in. The man in charge offered to give this late-season group boat service on the lake until four o'clock in the afternoon. But he explained that this was the last time he would go down the trail and that, before returning to the Lodge, he would haul out the boats for winter.

But it was not this circumstance alone that had brought about Jim's plight.

On the long motor trip, he had been in the habit of riding sometimes in his uncle's car and sometimes in that of the Smiths. After the trip to Crater Lake the two cars expected to separate. His aunt and uncle intended to go back to Portland by way of Medford and the Pacific Highway, while the Smiths meant to tour the country a week longer, returning to Portland by way of Klamath Falls and Eastern Oregon. Jim was free to go with either, but perhaps for that very reason he was deliberating as to which it would be.

He was still postponing his decision when, at the edge of the lake, Mr. and Mrs. Smith took passage in one crowded motor-boat, his uncle and aunt in another, while he selected a rowboat with two cordial strangers, inclined, like himself, to fish for the famous trout of Crater Lake.

He was having some luck with the fish and was by no means ready to go, when his aunt and uncle hailed him from a motor-boat that drew up to take him aboard.

"Are you going with us or the Smiths?" they asked. "We are starting right away and expect to get to Medford to-night. The Smiths won't be leaving for a couple of hours. We have already told them our plans. They said to be at their car at four o'clock, if you are going with them. If you are not on hand at that time, they will know you have gone with us."

Jim was reluctant to give up his fishing, and this reluctance prompted his decision.

"I'll go with the Smiths," he said. "Take these three fish for your supper at Medford. Good-by. I'll see you next week in Portland."

"Good-by," returned his aunt and uncle. "Be sure to be at the Smiths' car not later than four o'clock. We won't see them again."

At a small recession in the universal wall, on a tiny shelf or beach, where the water was deep and where the fishing seemed even more promising than from the boat, Jim asked to be put ashore. He told the men in the rowboat that he would catch one of the launches as it came by and that they did not need to wait for him or bother to call for him later.

Glad of the chance for two hours more of fishing, he expected to catch the motorboat in which the Smiths were touring the lake. But this boat failed, after a long interval, to appear. He remembered now that it had come this way when it started out. He saw it, far on the other side of the lake, going in the direction of the landing and the foot of the trail. He shouted, but they did not hear him. He waved his hands and his handkerchief, but they did not see him. The boat disappeared from sight!

He expected that another boat of some sort would be along, but as he scanned the surface of the lake he saw none. None put out from behind Wizard Island. He looked at his watch. It was a quarter of four. He remembered what the caretaker of the Lodge had said—at four he would begin hauling out the boats for winter. Even now he was probably covering them with tarpaulin. No more oars would dip in the blue waters before the next summer. The deep silence would be unbroken by the *chug-chug* of a motor. Navigation had ceased upon the lake, which was being left to its long winter solitude.

He was stranded!

He began to shout at the top of his voice, but he was more than two miles from the boat landing, and the near-by walls caught

and returned his calls in echoes. He kept shouting until he was hoarse and his throat was sore. It did no good. Nobody heard him, nor was it possible for him to be heard.

The chance was no better that anybody would see him. The wall back of him went straight up for a hundred feet. From that point it slanted backward toward the rim. He had noticed this topography when he had approached it by boat in the morning. If the whole face of the wall had been perpendicular, there would have been more hope of attracting the attention of a possible observer from above. But the sloping upper part and the sheer drop at the bottom put him in a concealed position. He could no more be seen than some one leaning close against the side of a house could be seen by a person sitting on the ridge of the roof. He was completely out of the line of sight.

Nobody knew that he was shut up in that great caldron. His aunt and uncle thought he was with the Smiths. The Smiths thought he was with his aunt and uncle. It would be a week before they would see each other in Portland and find out that he was missing.

The caretaker of the Lodge would not be coming back down to the lake. He had made his final visit. He would be working back at the Lodge. There was no way to attract his attention.

Could he survive until his uncle found out what had happened, or was he doomed to a grave in the lake he had so long looked forward to seeing? He had two jelly sandwiches and two raw fish. He would not starve, but if winter set in, scantily clad as he was, he could not live through the cold of seven autumn nights. His imagination took a tragic direction. Maybe his aunt and uncle would never find him. The next summer, boats would pass by the little beach where he stood. The deep snows in the meantime would have come and gone. The people in the boats would be startled by what they saw there. The world would know that a boy had been left to perish in that great abyss of the Cascades, giving fresh fears to the Indians, who refuse to look upon its enchanted waters.

He recalled the Indian legends of the lake and of its sinister toll of savage life. He had read them idly in a folder. They now assumed an oppressive meaning. For an hour or more he was entirely miserable.

Then his thoughts began to take a more practical turn. If he could get over to

Wizard Island diagonally in front of him, he might signal successfully from its top. But three quarters of a mile or so of deep water intervened between him and it. He could n't swim it clothed; he doubted whether he could swim it at all. If he stripped and succeeded in getting across, there was no telling how long he would have to remain, exposed to the October chill of mountain nights, before attracting help. He would surely freeze.

Around the edge of the lake from where he stood it was more than two miles to the boat landing and the beginning of the trail. There would be a few short stretches of beach along which he could walk, or shallow water which he could wade; but for the most part, there would be deep water bordered by perpendicular walls offering no supporting hold for a cold and exhausted swimmer. Again, he would have to leave his clothes behind. The frigid October night that kept him walking his little beach for warmth reminded him that such a course would be suicide.

It would be better, he decided, to wait till his uncle began a search, rather than try to gain Wizard Island or the trail, with almost certain failure ahead in either attempt.

His mind worked round to the idea of a signal. He took an inventory of his possessions in the dark. He had two raw fish, as has been said, and two jelly sandwiches, wrapped thickly in newspaper. He had his watch, his jack-knife, one hundred feet of heavy three-ply trolling-line, with fifteen feet of leader, fifty feet of smaller fishing-line, with a short leader, and an alder pole that he had cut while coming down the trail that morning. For the purpose of getting a signal up to the rim, there seemed no value in all this. He included his clothes in the inventory. Although he had done so several times before, he felt again for matches, but found none. All he found in his pockets, in addition to his handkerchief, knife, purse, and watch, was what he remembered was a little book of one-cent stamps, which seemed worthless enough at that place and time. In his impatience at finding this stamp-book instead of matches, he had an impulse to send it sailing out into the lake. But he put it back in his pocket.

Upon reflection, he was less disappointed about the matches. He had nothing to burn except a small pine board which he had found upon his little beach, the newspaper in which his sandwiches were wrapped, the stamps, and possibly his green alder fishing-



rod, if it were whittled into fine enough shavings. Such scant fuel would not produce a flame that would be discernible over the thousand-foot precipice that shut him in, nor produce a volume of smoke that would rise to such a height before dissolving into the air. With a match, however, and this

and attempted to get some sleep. He dozed fitfully. Frequently he would have to get up to exercise his cramped and chilled legs and to thaw out his congealed blood.

In the morning he ate one of his two jelly sandwiches. He would eat the second one the next day; after that, the raw fish.



"AT LAST HE HAD SLIGHTLY MORE THAN TWO THOUSAND FEET OF STRING"

meager supply of wood, he might have been able to cook one of his fish.

He realized he could n't give a signal, for he had nothing to give it with—nothing that could remotely be worked into a signaling device of any kind. He would simply have to wait a week until his uncle began a search and trust that the Cascade storms would hold off.

His teeth chattered with the cold. The prospect of spending seven such nights as this was dismal enough.

His mind tired out with thoughts that got him nowhere, and his legs weary from pacing his small refuge, he sat down with his back against the wall, put his coat over his head,

He had no more idea of how he was going to get out of Crater Lake than he had had the night before. But he was more reconciled to his plight, and his mind, freed from panic, was clearer.

While rummaging in his pockets, he idly took out the book of one-cent stamps and turned through the green rectangles of the pictured Ben Franklin. He wet his finger and tested the gummed lower surfaces. This time he had no impulse to throw them into the lake. He would n't have traded the little stamp-book for ten thousand matches. He put it carefully back into his pocket as though it were a great treasure.

He had hit upon a possible way of giving a

signal. He meant to work out his plan with great care, taking all the time necessary. The man undoubtedly was still at the Lodge. He could scarcely have finished his work so soon. If this man's attention could be attracted, Jim felt there was a good chance that he would be rescued. But the only way was to get a signal above that thousand-foot wall that hemmed him in. It was n't likely that the caretaker of the Lodge, who was an old-timer in the region, would give any particular scrutiny to Crater Lake scenery. He might not find it convenient to walk down to the edge of the rim to look out over the magic blue waters of the lake. At best, he would be a passive observer. An occasional and indifferent glance across the lake, as he straightened up from his labors, was as much as could be expected from him. To catch and hold the man's eyes during one of their casual and roving inspections of the landscape—that was what Jim meant to do.

Gradually he was figuring it all out. He was certain he could do it if the wind would blow—blow only hard enough to ruffle the smooth water shut in by those protecting walls. The afternoon before, he had seen it shake the firs on the rim, like prune-trees under the hands of the harvesters, and had felt it descend a thousand feet to where he stood, not wholly becalmed. A breeze, a breeze—that, above all else, he wanted. That necessity alone was now absent from his inventory, which he took once more, this time with definite purpose.

Laying aside his remaining sandwich for the next morning's consumption, he smoothed out the newspaper that had wrapped it and its fellows. In one place a jelly stain had soaked through, moistening and weakening the fabric beyond all use, but this was in such a position that an unharmed area of paper two feet square could be secured. He placed the paper on a dry rock. He picked up the pine board, whittled off some shavings to test its soundness, and placed it beside the paper. To the collection on the rock he added his hundred feet of trolling-line, his smaller fishing-line of fifty feet, and the leader from both lines. On top of all he placed the little book of stamps as the crowning jewel of his possessions. If any one had been there to see, he would have wondered what purpose this miscellany was meant to serve.

The first thing Jim did was to untwist the three strands of his trolling-line, securing three hundred feet of cord instead of one

hundred. In the same way he got one hundred feet from his fifty feet of small line. The untwisting of the kinky and corkscrewing strands completed, he surveyed the resulting four hundred feet of stout cord, but regarded it as only a good beginning toward his complete needs.

He pulled off his high-topped boots, removed his long woolen socks, put his boots back on bare feet, and began unraveling the socks. These yielded two big balls of thread. But as he tested the strength of the yarn he was not satisfied. Reversing the process of the fishing-lines, he twisted the two strands tightly together until the two balls of yarn formed a double cord. This had cut the length in half, which was n't enough for his purpose. He drafted still another garment—he took off his sweater and reduced it likewise to twine, which he doubled and twisted as in the case of the yarn from the socks. At last he had, all told, slightly more than two thousand feet of string. This cordage manufacture, however, had consumed the whole day. Darkness came and forbade further labor.

Once more, sleep was difficult, in spite of the fact that it was greatly in arrears. He suffered from the cold more than he had the night before, for he was now deprived of his socks and sweater. The hours seemed interminably long, but he obtained a few brief periods of repose.

In the morning, while it was still dark, he ate his last sandwich; and as soon as it was light enough, he took his knife and whittled from the pine board three straight thin strips. Two of these splits were about twenty-three inches long. The third was about fifteen inches long. The two longer ones he crossed in the form of an "X," but with the intersection three or four inches from the center toward the upper ends. The third and shorter he placed horizontally across the other two, its center at their intersection. He lashed the joint with cord. Around the outside, in grooves previously cut in the six ends of the three sticks, he stretched the leader of his trolling-line, so that he had a strong and rigid six-sided framework.

With his knife, he cut from the newspaper a covering of the same shape as the framework, but with an inch margin all round.

On a smooth, dry place on his little beach he laid down the paper, and, over this, the framework of sticks and catgut. He then took out of his pocket the book of stamps.



With his knife he cut each of the nineteen stamps into four pieces, making in all seventy-six gummed seals, quite narrow, but long enough in each case to have much adhesive tenacity. With these stickers he fastened down the border of paper, which he folded over the catgut rim.

Crossing and adjusting three strings with great care and exactness, he fashioned a "bridle," and arranged a short pendant loop at the lower end.

To the crossed strings, or bridle, he tied one end of his two thousand feet of twine. He tore his handkerchief into strips, which he pieced into a string and which he tied in the center of the pendant loop. Then from his shirt, he slashed off a section of additional cloth and tied it to the lower end of the handkerchief string.

The signal was ready to carry upward its message of an imprisoned boy. Jim had built a kite!

A breeze to fly it was the next need. He held it up in front of him, but the pressure against it was hardly noticeable. Something of the calm of morning still prevailed. He looked across and up at his barometers on the rim,—the trees,—and saw by their comparative quiet that the wind had not yet come in from the mountain-tops. He would be patient until the afternoon.

At two o'clock, from a perch as high up as he could gain, he held the precious kite above his head. If it ever dropped into the water, all his labor would be lost. He held the kite up and threw it from him, but it dropped down, not to the water, for he gave it but little line, and besides, he held the tail in his hand. It seemed a lifeless thing.

Many times he tried. Always it dropped. It seemed without buoyancy. It was heavy and spiritless, without the grace and lightness of flight. His heart sank. It would not fly!

He adjusted and readjusted the bridle. He subtracted from and added to the tail. Still it fell like a shot bird. For an hour he tried.

In the meantime, the wind increased. The firs on the rim no longer stood still, but bowed and courtesied. Out from shore the surface of the water had lost some of its glassy smoothness. The reflection of the wall in front of him trembled slightly. The sweat that came out on his face from his anxiety and his labors was evaporated quickly.

He kept trying, and at last began to have periodical promises of success. Finally, a

breath of wind bellied the kite and tautened the paper against the sticks back of it. He threw it out several feet. A timely breeze that he felt against his cheek caught it. It shot out straight and even rose a little. He dropped the tail and gradually let out line. The kite darted from side to side, and once it made a quick dart downward like an airplane on a tail-dive—it was a dangerous moment. But it rallied like an airplane, though the tail dripped a few drops of water as it rose. Steadied by that tail, it climbed diagonally upward above the blue of the lake slowly toward the blue of the sky. It began to pull so strongly that Jim had a new alarm. But he let out string—two hundred feet, five hundred, a thousand, and at last two thousand.

It hung in the air at a great altitude, its tail, the crudities of which were softened by the distance, waving beneath it. It soared high enough above the sunken waters of the lake and far enough away from the encircling cliffs so that it could surely be seen from the Lodge, if there was anybody at the Lodge to see.

He took what remained of the newspaper, tore it into round pieces the size of saucers, punched a hole in the center of each, and strung them on the kite-string in his hand. From time to time he would let one of these loose and watch it scud up the string to the kite. He hoped these might help to guide the caretaker of the Lodge to the base of the string and to himself.

But it began to be dusk, and still no sign that anybody had seen the kite. After all, had the man fastened up the doors, prepared the building against the winter storms, and left? Had no stray and late-season tourist paused for a moment on the edge of the crater? He was beginning to debate whether to pull the kite in or risk leaving it up all night. He might have trouble or find it altogether impossible to get it to fly again in the morning if he drew it in. But if he left it out, there might be snow or rain, the wind might grow too strong or die down, the all-night pull might weaken the string, and any of these contingencies would be hazardous to the kite.

At last he heard the exhaust of a motor-boat in the direction where the trail led up from the lake to the Lodge. The staccato beats at first sounded a great distance away, but soon the *chug-chug* grew closer and friendly calls were added to the sounds of navigation.

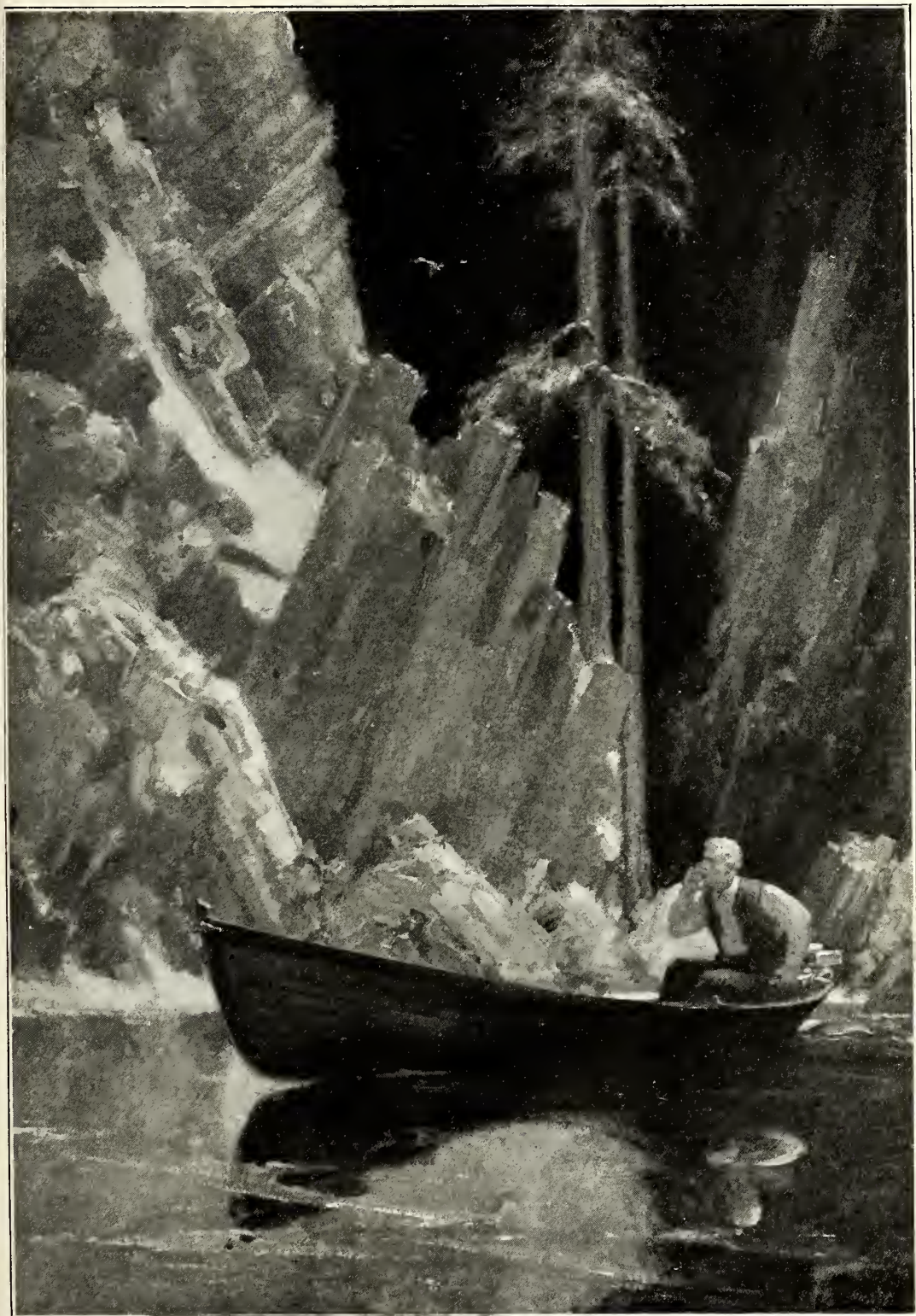

“‘WHERE ARE YOU?’ HE HEARD. ‘WHERE ARE YOU?’” (SEE NEXT PAGE)



"Where are you?" he heard. "Where are you?" repeated frequently and loudly.

"Here," answered Jim. "Here—over here!"

The boat came up to the little beach, and Jim, still holding the kite-string, greeted the caretaker of the Lodge.

"It 's a good thing you flew that kite," Jim's rescuer told him. "I never dreamed anybody was down here. I thought it was a bird at first. But I looked over there several times from where I was working at the Lodge and thought it was n't quite natural for a bird to do like that—to stay high up in the air above the lake in about the same place, not moving much and sort of hanging there like it was held up by a string from the sky. A smaller bird kept right underneath it. So I came down to the edge of the rim and got a closer look. You can imagine how surprised I was when I saw it was a kite and that the second bird was the kite's tail. I could n't figure it out. The only way I could explain it was that maybe somebody had left it flying without my noticing it before. I took a squint through the field-glasses that I brought along and saw pieces of paper mounting up to it, and remembered how we used to do that when I was a boy. So I reckoned somebody was down here at the bottom end of the kite-string, who was

signaling and who needed help pretty bad. It made me kind of shiver when I realized it was probably some one everybody had forgotten and left at some part of the lake where he could n't get back to the trail. So I beat it down here faster than I ever did before. Jim did you say your name is? Well, turn loose the string and let 'er go. It 'll probably land over on the other side of the lake somewhere. It saved your life and no mistake, for you might never have got out of here. Jump into the boat, Jim, and we 'll go. There 's a warm fire in the fireplace at the Lodge and something to eat. You must be about frozen,—here, put on my coat,—and I expect you could eat a whole ham.

"It sure was lucky," he went on, as he started the motor-boat, "it sure was lucky you flew that kite. But how did you make it, Jim? Where did you get your stickem? When I was a boy we used to make paste out of flour and water. Did you have a tube of glue or paste in your pocket, maybe?"

"No, I used postage-stamps," said Jim; "one-cent stamps," he added, as though two-cent stamps and the multiple image of George Washington might not have had the same result at all. "You see," he explained, "Ben Franklin's picture on the stamps suggested the idea of a kite to me."



Photograph by courtesy of the Department of the Interior

VIEW FROM CRATER LAKE LODGE, WESTWARD OF WIZARD ISLAND

# THE WORKSHOP OF THE MIND

By HALLAM HAWKSWORTH

## CHAPTER VII

### IN THE PLAYGROUNDS OF THE MIND

YOU had a good time this summer, did n't you? And how much you must have learned about "the tenants of the wood," and the tortoise and his shell, and the woodchuck and his cell, and the gray-hornet artisans—and all the rest of them.

My! the numbers of woodchucks I've met up here in the Berkshires this summer and the hornets and the bumble-bees—many of them face to face.

"Knowledge never learned of schools," said Whittier, and this was true when he said it; but fortunately, you and I live in a later and better day, when the teachers go to school to the children and to the play-spirit and the out-of-doors; when children and teachers go into the woods and fields together and bring the flowers and the frogs and the work of "the gray-hornet artisans" right into the school-room.

And—speaking of hornets' nests—the transfer of property from the original owners is quite an education in itself. How does Riley put it?

Another said, "A mile from there I wisht we 'd let it be!"

#### I. SOME BOYS YOU KNOW

DOES N'T it beat anything, the mad pranks boys play in vacation time? For instance, there's a certain boy I know of who took it into his head to blacken with burnt cork the face of the prime minister of England, at whose country-place he was visiting. So, with the help of another boy who was also a guest, he burnt the cork and together they waylaid the great man and attacked him.

Things were getting interesting when who should call but Lord Castelreagh and Lord Liverpool to consult the premier on some affair of state.

"Let them wait in the other room," said the premier, and he instantly returned to the battle; "catching up a cushion and belaboring us with it in glorious fun," as one of the boys said some time afterward, in relating the incident.

"We were, however, too many for him, and, after a ten minutes' fight, got him down and were daubing his face with the cork when he

said: 'Stop, that will do. I could easily beat you both, but we must not keep these grandees waiting any longer.'

"We were obliged to get a towel and a basin of water and wash him clean before he could receive his distinguished visitors. Things being put in order, the basin was hid behind the sofa and the lords were ushered in."

The premier was William Pitt, one of the greatest of England's statesmen and orators, the man who, in those historic debates, used to wither his opponents by the mere flash of his eagle eye. The other two "boys" were Charles, Earl of Stanhope, and his brother James—both distinguished men, as you can see by looking them up in the "Century Dictionary of Names."

The earl who tells the story, says:

Pitt not only delighted to play games with children, but liked this sort of practical fun, and used to riot in it with Lady Hester [Pitt's sister and wife of the earl], my brother James, and myself.

Play and work, work and play—these seem to be the "tick" and the "tock" of the pendulum of life; or, if we compare the human machine to a watch, play and work are the winding and unwinding of the mainspring.

The biggest minds seem to get the most fun out of the most ridiculous things. Who is that over there? See him; he's trying to balance a peacock feather on the end of his nose! If you have never heard about this odd amusement of his, you would certainly never guess that he is a philosopher—and a famous one too. It is Dugald Stewart, the eminent Scotchman, a professor in Edinburgh University, whose lectures covered a remarkable range of subjects—psychology, metaphysics, logic, ethics, natural theology, political economy, goodness knows what all! Yet he was n't ashamed of playing the boy in this way. He even used to get his friends to try it. A gentleman who called on one occasion found that he had induced Tytler, the historian, to come into the game. I'd like to know who won, would n't you?

Again, to continue this story of the play-days of the famous, we are in the drawing-room of the country-seat of an English lord; any number of fine people are there besides ourselves—members of the first families of the



realm. Up jumps my lord, and, to a dance tune of his own singing, does a lively step all over the room—here, there, everywhere. Then, with a smile, as he pauses for breath and looks around at the company convulsed with laughter:

“Oh, you don’t know what a luxury it is to an overworked brain to play the fool among one’s friends!”

This is Lord Eldon, one of the most eminent of the chancellors of the English bench, whose decisions have helped build up the mighty fabric of the law under which the whole English-speaking race holds its security of life and property.

Canning, another English earl, an eminent statesman and at one time governor of India, loved to play blindman’s buff. This, by the way, was one of Napoleon’s favorite forms of relaxation, of which he had several—for the great emperor was always up to something in his hours of ease. Did you ever hear how he once tried to drive a coach and four? One day he was with the Empress Josephine, his prime minister, and some distinguished foreigner in a state carriage drawn by four very spirited horses. The other occupants of the carriage remarked with admiration the easy skill with which the coachman, who was known as Cæsar, managed them.

“He does it well, to be sure,” said the emperor, “but I myself know perfectly the management of horses. I have, you remember,” he added with a smile, “had some little experience in this line in time of battle.” The spoiled boy of Fortune thought, you see, that he could do anything he chose to turn his hand to. So he proposed forthwith to put his ability in this direction to the proof. In spite of the combined protestations of the empress and the coachman and those of his prime minister and his guest, the conqueror of Europe climbed into the seat and took the reins.

It was only a few moments before the horses were completely out of control and, dashing wildly along, struck some obstacle,—a stone by the roadside perhaps,—spilled everybody, and knocked the emperor senseless. Being lifted from the ground, he quickly recovered consciousness, however, laughed heartily as his royal person was being dusted off, and then, picking up the whip which lay at his feet, handed it with a courtly bow to the coachman.

“‘Render unto Cæsar the things that are Cæsar’s,’” said he. “Let every man confine himself to his own business.”

There is a charming anecdote of another king of France, Henry IV—Henry of Navarre. The Spanish ambassador, calling to see him on some grave affair, found him on all fours playing horse for his children, one of whom was on his back, the other dancing along by the horse’s head. Looking up, “You are a father, Signor Ambassador,” said he, “so you will not object to waiting a little, I am sure, while we finish our morning ride.”

The kings and queens of the Land of Play, the children themselves, are thus, it is pleasing to reflect, often largely responsible for keeping their elders young. Take Dickens, as an instance, and how once upon a time he jumped out of his bed in the middle of the night and began dancing—practising certain steps in preparation for a party to be given for one of his children. He had been thinking over this dance, which was to be one of the chief features of the program, and was n’t quite sure if he had it properly in his mind. The great story-writer was always the heart and soul of these parties. Writing to a friend, he said:

The actuary of the national debt could n’t calculate the number of children who are coming here on Twelfth Night in honor of Charley’s birthday, for which I have provided a magic-lantern and other divers engines of a like nature. But the best of it is that Foster [Foster was an intimate friend and afterward his biographer] and I have purchased the entire stock-in-trade of a conjurer, the practice and display whereof is entrusted to me.

And, oh my dear eyes! if you could see me conjuring the company’s watches into impossible tea-caddies and causing pieces of money to fly away and burning pocket-handkerchiefs without hurting them and practising in my own room without any one to admire, you would never forget it as long as you live.

That’s the kind of jolly letters Dickens used to write to his friends. Friendship was like wine to his fine, sensitive nature, and it brought out the best there was in him. For them, in his letters or in conversation, he sketched characters with all the artistic touch you find in his novels—told stories, acted charades, played games, took part in amateur theatricals.

“Playing I am somebody else,” he said, “has charms so delightful that I feel a loss of, oh, I can’t say what exquisite foolery, when I lose the chance of being some one not in the remotest degree like myself.”

A good point, that, for us, it seems to me. To every child it comes as natural as anything to pretend to be somebody else—or several



"WE WERE, HOWEVER, TOO MANY FOR HIM, AND GOT HIM DOWN, DAUBING HIS FACE WITH THE CORK"

somebodies-else, even; and pretending you are somebody else, gets you outside of your every-day self. Thus your real self gets a rest. Something like that, don't you think so?

Take the case of the dear little brown-eyed miss at a country-place where I recently spent a week-end.

"Is that you, dear? Where is Marie—in town?"

"Oh, no, dear, she's spending the week-end at the Van Twilligan's. Can't you run down here in the machine?"

This was an imaginary long-distance conversation over the telephone, with my little miss impersonating both ladies, each in an entirely different manner and tone of voice.

When Dickens was in America his good spirits knew no bounds. Of his arrival in Boston, Fields, the publisher, says in his reminiscences:

How well I recall the bleak winter evening in 1842 when I first saw the handsome, glowing face of the young man who was, even then, famous over half the globe. He came bounding

into the Tremont House fresh from the steamer. He almost flew up the steps of the hotel and sprang into the hall.

"Here we are!" he shouted, as several gentlemen came forward to meet him.

What vigor, what keenness, what freshness of spirit possessed him!

Of Thackeray's exuberance during his visit to America, Mr. Fields says:

He seemed like a school-boy just released from his tasks. In the midst of the most serious topics under discussion, he was fond of asking permission to sing a comic song; or he would beg to be allowed to enliven the occasion by the instant introduction of a double shuffle.

His letters also bubbled over with all sorts of whimsicalities. Sometimes he would write in so fine a hand that it could be read only with a magnifying glass. He greatly delighted in writing notes in rhyme. Macaulay used to do the same thing in writing to his sisters. Here is a part of one of these letters:

Next Sunday I am going to Lord Lansdowne's at Richmond, so that I hope to have something to tell you. But, on second thoughts, I will



tell you nothing, nor ever will write you again, nor ever speak to you again. I have no pleasure in writing to undutiful sisters. *Why* do you not send me longer letters? But I am at the end of my paper, so that I have no more room to scold.

Ever yours,

T. B. M.

"I will tell you nothing, nor ever write you again, etc."

If I had n't already told you this was from a letter of the great Lord Macaulay, would n't you have said it was from some girl's letter to a chum, reproving her for not writing more or oftener?

By the way, did you write to your friends at home as often or as much as you promised? Or did you only intend to, as so many of us do in the long summer vacation? I know how it is. You ought to see the long letters I did n't write. We all ought to take a lesson from these famous letter-writers, who found so much amusement in making others happy at long distance.

When Darwin was in South America he asked one of the natives, a Gaucho, why his people did n't do more work, when there were so many things that needed to be done.

"Oh," said the Gaucho, stretching himself, "the days are too long."

So you see there is such a thing as overdoing this vacation business.

## II. HOW THE LEGS HELP THE BRAIN TO THINK

THERE is a Greek fable—is it in *Æsop*?—about a dispute among the members of the body as to which does the most work for the community—the little republic of which they form a part. I don't remember just how the story goes, but the upshot of it is that each part considers itself the most necessary to the well-being of the whole. The truth is, as you know, that there are only a few organs that are absolutely essential to life; but measuring life in deeds, not years, I should n't wonder if, among the "accessories" of this marvelous automobile of ours, the legs would walk away with the honors.

Take the brain itself. It does n't do its best work unless the legs are kept reasonably busy, and finally the whole body breaks down, and that is the end of everything. So it was with poor Thackeray, that great and versatile mind and most delightful of men. While Dickens and many other famous men were great walkers, Thackeray rarely walked—took little exercise of any kind. He had a remarkably strong physique, which gave

promise of a long life, but he used his brain too much and his legs too little.

Born into a family with plenty of money, he formed luxurious habits of eating and drinking, and never took to athletics or the out-of-doors, as most Englishmen do. The rule of "plain living and high thinking," he used to say, should read "high living and high thinking." To the loss and sorrow of the world, he was cut off in the fullness of his powers, dying alone in his rooms from an effusion of blood on the brain—apoplexy. It is to apoplexy that men of full habit, as Thackeray was, are especially liable. A golf-club has proved to be worth more than all the rest of his fortune to many an American millionaire. The game and the exercise and the companionship relieve a brain weary with its work, draw away from it the congestion of blood caused by too much thinking, and purify the blood for the service of the body as a whole.

But plain walking, without the golf-stick, has been largely responsible for some of the best treasures men have left us in their lives and work. Walking was the favorite exercise and pastime of Dickens. Seldom did a day pass, rain or shine, that he did n't do his eight, ten, sometimes fifteen miles and more. Often he went alone, but he preferred a congenial companion. Then he fairly ran over with humor, and as they went along the country roads he would frequently act the parts of characters in his novels.

Scott, in spite of his lameness, was fond of walking as well as riding. On Sundays he always walked. He said horses had as good a right as man to their day of rest. After he had read the church service he usually walked with the whole family—including his beloved dogs, of course—to some favorite spot, and there they spread on the grass the contents of a big basket.

Wordsworth was a famous walker. In the course of his rambles he must, it is estimated, have traveled 180,000 miles. "This exercise," said he, "stood to me instead of wine and all other stimulants, and to it I am indebted for a long life [eighty years] of unclouded happiness."

It was on these long walks among the beautiful scenes about Lake Windermere that Wordsworth composed many of his best-known poems, drawing, like a painter, directly from nature. Tennyson, that "swarthy giant," also composed while walking—set nature to music to the rhythm of his legs. It was on his walks in the fields and woods and

by the inland waters and the sea that on glorious mornings, "loud with the voices of the birds," he saw the lark become a "sightless song" and listened for the linnet's note "in the

leaf is whirled away" and "the rooks are blown about the skies."

Of Macaulay it was said that the only exercise in which he excelled was threading the crowded streets of London with a book in his hand. But this was merely a witty hit by one of his friends at his insatiable appetite for reading. As a matter of fact, he was always very fond of sight-seeing and was never so happy as when he could take his sisters—and after they were married and had children, these nephews and nieces—for a round of the great city. He used to keep up this sight-seeing until, as he said, he "could n't drag one leg after another." Of these walks, Lady Trevelyan—Hannah Macaulay—says in her husband's biography of her brilliant brother (one of the best biographies ever written and one you should by all means read):

In the morning he worked and studied. In the afternoon he always took my sister Margaret and myself for a long walk. We traversed every part of the city—Islington, Clerkenwell, and the parks—returning just in time for a six o'clock dinner. Then, after dinner, came our noisy mirth and his wretched puns, so many a minute, so many an hour.



"LET 'S TRY," SAID THE MAN, AS HE MOUNTED THE ANIMAL" (SEE NEXT PAGE)

pauses of the wind"; with the decline of day, watched the lily "fold all her sweetness up and slip into the bosom of the lake"; at twilight, the bats that "haunt the dusk." You can see that he was out at all seasons and in all kinds of weather too:

With earliest light of spring,  
And in the glow of fallow summertide,  
And in red autumn, when the winds are wild,  
and the sea-winds blow "shrill, chill, with flakes of foam"; autumn when "the last red

It is very common for men in all lines to do their best thinking "on their feet," as we say of the brilliant, extemporaneous flights of orators. Walking stimulates the even flow of blood throughout the system, so that the brain gets its share. It also, as we said in speaking of golf, draws blood away from the head when one has too much in that region—is "thick-headed," as we say. Many business men, when they have particularly important letters to dictate, get up and walk back and



forth. Napoleon used to do this, and as he often turned his back on his secretaries and never would repeat anything, it made it rather hard for them. One of the best-known of our big business men says that he and his partners, in the early days of the business, used to solve some of their knottiest problems in their walks to and from the noonday meal at their homes in the comparatively small city in which they lived at the time.

Some eminent men have preferred horse-back-riding to walking. And that reminds me of a story of a certain famous man and some boys and a donkey. This man was not only very fond of horses and riding, but he particularly prided himself on taking some animal no one else could control and making him do whatever he wanted—all without the use of whip or spur. One day he came upon some boys who, without saddle or bridle, were trying to ride a donkey. They were no sooner seated, however, than Mr. Donkey down with his head and up with his heels and sent them sprawling.

"Why, boys," said the stranger, in a bantering tone, "is it possible that none of you know how to ride?"

"We don't believe even you, sir, could sit him," replied one of the lads. (Being an English lad, he, of course, had a peculiar way of saying "ride him.")

"Let 's try," said the man, as he mounted the animal, who began to kick up his heels and lower his head as before. But the old tricks would n't answer with this passenger, who compelled him to go wherever he chose.

Laughing, he resigned the donkey to the boys, who were more impressed, no doubt, by the magic power of this strange man over the unruly little beast than if they had known he was the great Warren Hastings, ruler of India and builder of the vast Indian Empire of Great Britain on the foundations laid by Clive.

Of curious ways of using the legs for the service of the overworked brain, that of Cardinal Richelieu comes to mind. You may have seen him in a recent movie-play—cold, stern, with a face as pale as white marble and as hard; and you know that he was the real ruler of France in his time, and made her the foremost power in Europe. Imagine him in a room with his servants trying to see who could, by jumping, reach the highest spot on the wall. A courtier one day found him doing this.

Cardinal Mazarin, whose ability led Richelieu to designate him as his successor, was fond of shutting himself up in his room and jump-

ing over a series of chairs, arranged according to the degrees of difficulty in clearing them—like the hazards in a golf-course. If the cardinal had lived in these days, he would probably have taken to golf. (It is said, to be sure, that some men do not care for golf; but this seems doubtful.)

### III. WHEN WORK IS PLAY

BUT however that may be, it is true of both work and play that you can't get the best out of either unless you enjoy it. I question whether Buonamico got any more fun out of that little practical joke of his with the beetles when he was a boy than he did in after years out of his work as a painter in which he applied so well the principles he learned of the master on whom the joke was played. Do you know the story?

The master had the habit, in the season when the nights were long of calling Buonamico and the other boys before daybreak. The boys hated to get up, much as boys do under similar circumstances to-day, I understand. So Buonamico applied his artistic ingenuity to the problem of doing something about it. Finally, he hit upon a bright idea. He got thirty big beetles from an old cellar, fastened little candles on their backs, and, just before the hour when the master was accustomed to call the boys, opened his chamber door very softly and put them in through the crack.

Waking in the darkness of those Middle Ages and seeing the strange moving lights, the master, terrified, fell on his knees, called on all the saints whose names he could think of on the spur of the moment, and then jumped into bed, hid himself under the covers, and lay there quaking until daylight. He never again woke the boys until the sun was well above the horizon.

With a still greater artist of the Middle Ages, Leonardo da Vinci, his art was not only an absorbing occupation, but sometimes a source of amusement; as when a friend of his, an aged dresser of vines, knowing his interest in grotesque specimens of nature's art, gave him a lizard that he had found sunning himself on the garden wall. A lizard at best is queer enough, but this specimen was the very queerest that ever was seen. Yet, still to improve nature's quaint fancy, what does Da Vinci do but make it wings,—nature's humble disciple that he was, he made them out of the scales of other lizards—painted huge red circles around the eyes, and gave it a pair of horns and a beard!

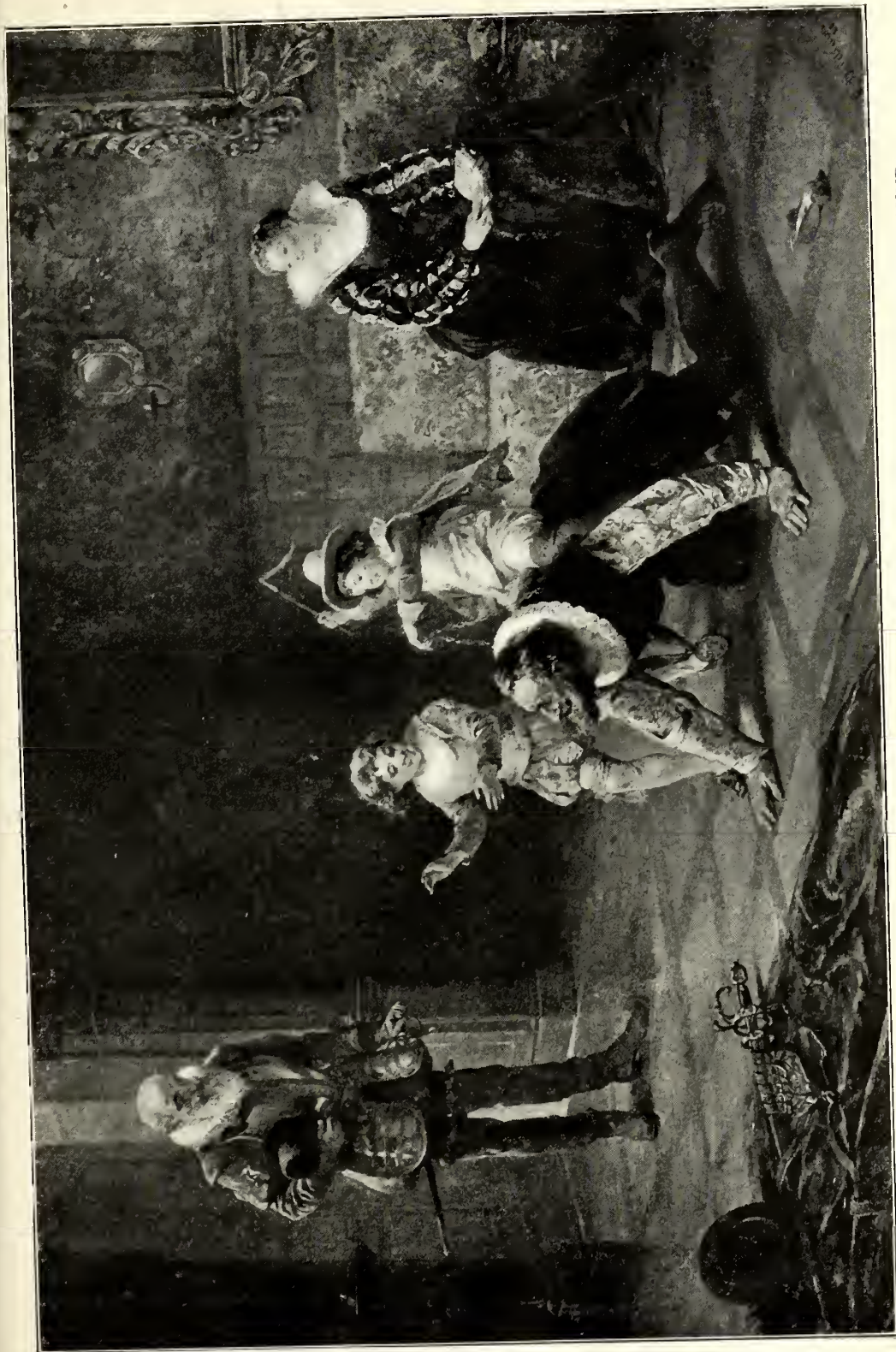

Painted by Robert A. Hillingford

“THE SPANISH AMBASSADOR, CALLING TO SEE KING HENRY IV ON SOME GRAVE AFFAIR, FOUND HIM ON ALL FOURS PLAYING HORSE FOR HIS CHILDREN” (SEE PAGE 1244)



“At sight of it people ran away.” Do you wonder, especially when you remember how superstitious people were in those days?

Another anecdote of da Vinci's interest in grotesque effects is, that in designing a monster coming out of his den among some rocks, he brought lizards, grasshoppers, serpents, bats, and the like to his studio. Ideas borrowed from the anatomy of all, formed into a kind of stock company, constituted the picture of the monster.

Of another youth who became an Old Master, it is related that in studying to be a sculptor, not satisfied with carving and modeling all day, nothing would do but he must draw all night. And when, with the draft made on his blood-supply by the brain and the lack of steam registers and janitor service in those days, his feet got cold in the course of the night, he put them in a basket of shavings and went on with his work. This was della Robbia.

Enjoyment of one's work prevents fatigue and sharpens all the powers of the mind. In taking exercise, it is n't a mere matter of using the muscles; interest in the walk or the game is necessary. The man with a little garden gets a good deal more benefit out of it, as far as body and mind are concerned, than the laborer in a market-garden; it is his plaything.

It is in the finding of the great fad, the great plaything, that boys who afterward become eminent men find themselves. Before that, they were just ordinary boys—some of them extraordinarily dull, so most people thought. Take, for example, a certain frail, English boy. He could make kites and wind mills and ingenious toys, but he stood low in his studies, and in one examination in mathematics, after he entered college, did so poorly that he almost flunked. But he finally became interested in astronomy, studied mathematics for astronomy's sake, and became none other than Sir Isaac Newton!

In the biographies of the men of every nation you will find similar instances. Fourier, a great French geometrician and physicist, was wilful, rebellious to all restraint, and apparently incapable of sticking to anything until his thirteenth year, when he accidentally discovered that mathematics is really a world of wonders. He immediately became a different boy, and later, an eminent man. Malebranche, the French philosopher, was a very ordinary youth until he picked up a volume of Descartes. The reading of it caused such a violent beating of his heart

that he was obliged to lay it aside for an hour. He had found himself! He discovered that he too was a philosopher! On which a French psychologist makes the remark:

Some, perhaps, will say such experiences are the marks of a dawning vocation, but what, indeed, is a vocation but attention discovering its way, its true bearings for the rest of life?

Here, as in the case of “attention” that Carlyle helped to make so interesting in Chapter II, the story of the birth of the word takes us into the depths of its meaning:

“Vocation, from *vocare*, to call,” says the dictionary.

Malebranche heard Descartes calling him from between the covers of that book:

“Come on in! This philosophy—as folks call it—this looking into the why of everything, is fine business!”

If there is one man in the whole history of science, from Aristotle on, whose name, if the matter were put to vote among other men of science, would probably rank first on account of the far-reaching effect of the truths he discovered and reasoned out, that man is Charles Darwin. In school the opinion of him was also unanimous, but to a quite different effect. This is from his autobiography:

When I left school I was considered by all my masters a very ordinary boy, rather below the common standard in intellect.

But he had a fad. He was, among other phases of his interest in the School of Out-of-doors, fond of collecting beetles, and it was the beetles that saved the day for him. He followed the beetles into the great Book of Nature, and there discovered—among several other important things, any one of which would have earned him a distinguished place—the most astounding of all nature's laws—the law of evolution, the method of creation of the whole world of living things!

Yet Darwin, like Newton, was a frail boy and all his life a frail man, but the study of Mother Nature's Puzzle Pages was at once his work and play. The capacity of being interested—intensely interested in something, some *one* thing—is hidden away somewhere in all children and is capable of you don't know what. Look around. Try this, try that, until you find what *your* some one thing is. Wonders can be accomplished when the energy and enthusiasm of play is concentrated into one ambition. There is such a thing as taking nature—your own nature, I mean—by storm. The increased

effectiveness which comes from enthusiasm—the play spirit—is so inevitable a thing, apparently, in the mechanics of nature, that we find it even in inanimate objects. For example, if the velocity of a stream flowing at a certain rate be doubled,—owing, say, to a heavy rainfall,—its effectiveness as a moving agent is not merely twice as great as it was before, but sixty-four times as great! So a boy who is “enthused” over his work—makes play of it—is not merely twice the boy he was, but, if the difference can be expressed in fig-

ures, sixty-four times himself—his ordinary self! To the enthusiasm of the boy carried over into the business of life, there are no hot days and no cold days. We have seen what the artist on the night shift did for his cold feet. Now listen to this little anecdote of Giotto and the King of Naples:

The king during a very hot summer said, “Giotto, now that it is so hot, I would give up painting a little, if I were you.”

“And so would I, if I were you,” replied Giotto.

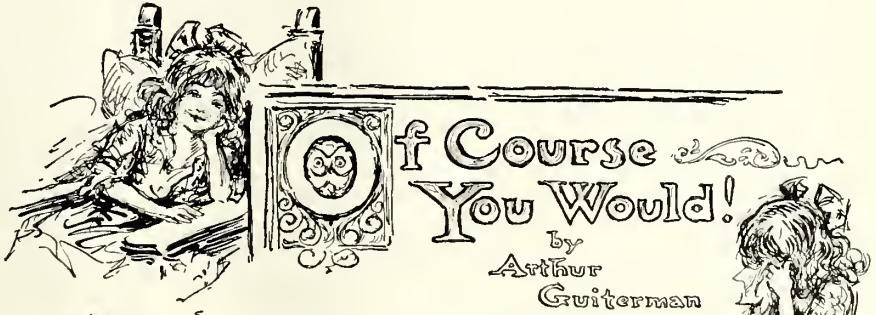

by  
Arthur  
Guiterman



Now would n't you smile  
At the elegant style  
Of an elephant walking on  
stilts?



And would n't you weep  
If a Barbary sheep  
Should lunch on your grand-  
mother's quilts?

And would n't you cry  
If a leopard should try  
To sing, and he did n't know how?  
And would n't you laugh  
If a flying giraffe  
Should light on the apple-tree  
bough!







"INDIAN SUMMER"

FROM THE PAINTING BY CHARLES C. CURRAN

# THE RIDE TO ORCHARD

By L. DEAN-HATCH

"WELL, Carter, you 'll take me across country to Orchard on the G. N. R., won't you? Now don't say you can't, because I simply must catch the seven o'clock train there. None here at Cadboro will get me to Chicago in time. And you 're the only fellow with 'git' enough in him to land me in Orchard before seven. Of course, I 'll make it worth your while—"

The man called Carter looked up, perplexity mingled with his habitually obliging smile. "I dunno, Mr. Portland. I 'd like to. But here 's this youngster I 've taken aboard 'fore you came—him, with all this junk—"

The junk referred to a box occupying half of the front seat of a battered automobile, along with sundry binder-blades, light sticks of new lumber, a mended auto-wheel, and various odds and ends of repairs and groceries piled into the back. There was barely room at the side of these last for a person to squeeze, and that room had already been engaged by the "youngster," who was myself.

The new-comer cast an appraising eye over the loaded car, and then divided a nervous glance between the empty street of a Western "shack" town and his watch.

"Any other time," went on Carter, scratching his gray-flecked hair, "there 'd be farmers in town, with cars, that could help us out. But in harvest you won't meet one of 'em in a ten-mile ride. Some farmer, too, is a-waitin' for every one of them repairs—"

Meanwhile, Mr. Portland, from surveying the street, had turned his square face and bushy eyebrows full in my direction, deliberately taking stock of a hitherto ignored opponent. He had the most eagle-like eyes of any man I had ever met. I knew that with one glance he already knew my eyes were gray, my trousers short, and my canvas grip of an age to be classed as a family heirloom.

I admit that I was in no mood for close inspection that day. I had not taken a sleeper from Chicago on, and had gone light on lunches, being reluctant to break the last ten-dollar bill folded flat in my purse, which alone stood between me and a tramp's life under naked prairie skies two thousand miles from home. Moreover, I was still only a boy of sixteen, although I had had to don long trousers because I had grown large and

tall so rapidly; and people were in the habit of looking to me for a man's part, especially after Uncle Tim's last long sickness had come on. And boys are extremely sensitive about awkward hands and matters of general appearance when eyed by polished, well-groomed men. Besides, I considered that this man Portland, for all his years and business urgency, was at least not in the strait of having to land a job on a farm before night in order to obtain a meal and shelter.

I decided to retain my foot in its former attitude of possession on the running-board of the old car.

Seeing retraction in neither of our faces, Mr. Carter's own showed signs of relenting. "I suppose I 'll have to fix you both out somehow. Thank fortune, my load 's bulkier than it is heavy."

Whereupon he set to work, rearranging his "junk" with a hand apparently grown adept with many emergencies. Both the man Portland and I lent what aid we could, and in a very short time some sort of niches had been made in which each of us might stow himself, and we were ready to set out. I occupied half of the front seat, holding on my knees the box which at first had been carefully packed there. Mr. Portland reposed in the back, with a brace of binder-blades resting on his shoulder and his club-bag supported by his feet.

However, Mr. Portland seemed extremely well pleased with his position. "I knew you could do it, Carter—never yet saw an occasion you were not equal to. If only I could lay hold of one or two dependable fellows like you in my business, I would n't be at my wit's end, as I am now."

"Dependable fellows don't grow on every bush, that 's a fact," sympathized the inventive Carter, taking a last look around for a forgotten wrench or radiator-cap.

"You 're right, they don't. There 's been a stampede of chaps along my way hunting for work this last while back. But you 've got to pretty well do it yourself, no matter how many of them you hire. Something goes wrong if I 'm out of the shop at Cadboro for a day. My business down in Wilders needs my attention this minute. And here 's this call to be in Chicago within twenty-four



hours. Life 's just one dilemma after another."

As we drove along I found myself getting interested in the man, not so much for what he said, as for the relieved way his grim face had cleared at the thought of reaching Orchard for the seven o'clock—as if this last were the conquering of one dilemma at least. It somehow set me thinking of Uncle Tim at those times when some burden had shifted from his work-weary shoulders and he took, as he used to say, a fresh lease on life.

Uncle Tim was all that I had ever known as a father. But he was now where fresh leases are not taken. And the old home where we all, Uncle Tim's children and I, had helped to make the burdens, had broken up and the children had themselves shifted east and west. Here was I, two thousand miles from home,—or what was left of home,—hunting work for my night's lodging. It was very different from the safe shelter where Uncle Tim had kept us all.

But I was young and full of hope. The fresh breeze racing past my ears was sunny as well as bracing. The strips of grain and chocolate-brown summer-fallow, spread about us on all sides, looked promising and substantial. Surely there was a place on the prairies for a boy with the body of a young giant and, I supposed, the average amount of brains.

It was probably because I was buoyed up by the intoxicating elixir of the fast drive through the fresh air that I for some time scarcely noticed the weight of the box on my knees. At any other time I should certainly have felt it unpleasantly heavy, for, on peering through a recent puncture in its side, I discovered it was filled with bottles—and by no means empty bottles at that. From time to time, also, I observed Mr. Carter casting solicitous glances at my burden.

It was true that the country through which we were passing had been voted dry, but I had not traveled half-way across a continent without ascertaining that an occasional leak will sometimes find its way into otherwise very well-drained territory. Boy that I was, I knew that in that box lay the secret of the seams in the man's kindly face, his frayed-out sleeve and the battered auto. Probably the secret, too, I thought, of why a man of such clever mechanical bent, as Carter seemed to be, was down on his luck enough to be banished to this new, out-of-the-way district.

We had gone, perhaps, some eight miles, when an extra fine stretch of wheat attracted my attention. Heavy, tall, and yellow, it stretched onward by the trail for a mile ahead.

"Great grain, that," observed Mr. Carter. "That one piece will lift the mortgage off of somebody's quarter-section, or go a long way toward it."

In looking very sharply at the piece as we sped by, my eye caught the intermittent, wayward bobbing of wheat-heads at the end of the strip nearest the trail, over which we were bouncing ahead at a somewhat reckless rate. In a second I knew quite well that that waving was.

"There 's cattle in that wheat," I told Mr. Carter. "What a pity! Both the stock and the grain will be badly damaged—if not ruined. The owners ought to be warned. Suppose you let me run in to that shack—there 's a telephone-wire going to it. I 'll sound a warning and be back in a jiffy."

But to this the hitherto compliant Carter proved obdurate.

"Portland is never going to see Orchard before seven if we don't stick to the trail and keep the old car moving. Somebody else 'll be sure to see the cattle. And anyhow, we can't take everybody's business on hand. 'T ain't calculated any of us can run the hull world."

No doubt, there was some truth in that. Mr. Portland evidently needed all his time. He was now eyeing his watch every five minutes. On the other hand, I could not help wondering what Uncle Tim would have said. In the old days at home, none of us would have dared hold up our heads in his presence if we had seen cattle in a man's grain without warning him. More than that, we would probably have been severely rebuked had we failed to help the man get them out.

I had just concluded persuading myself that the matter was entirely out of my hands, when "Bang!" went one of our tires. Almost simultaneously, Mr. Carter gave a dexterous twist to the wheel that brought the limping car out to the side of the trail. There was no doubt about it—we were winged!

In a trice the three of us were on the ground, working with bolts, jack, wrenches, and pump, and hunting out an inner tube from the tool-box. I could not help admiring the man Portland in this new extremity. His watch remained in his pocket. He never took time to utter a single word. He just

worked—worked like a Trojan. I felt myself becoming interested in a business which could so entirely engross a man of this stamp.

In the meantime, I did all I could to help with the tube. But the two others proved

Boyhood memories of Uncle Tim's rebukes seemed near to me that day—I took my chance. Setting my long legs racing, I tore over the prairie at a limber gait. But the ground had been cropped and was spongy.

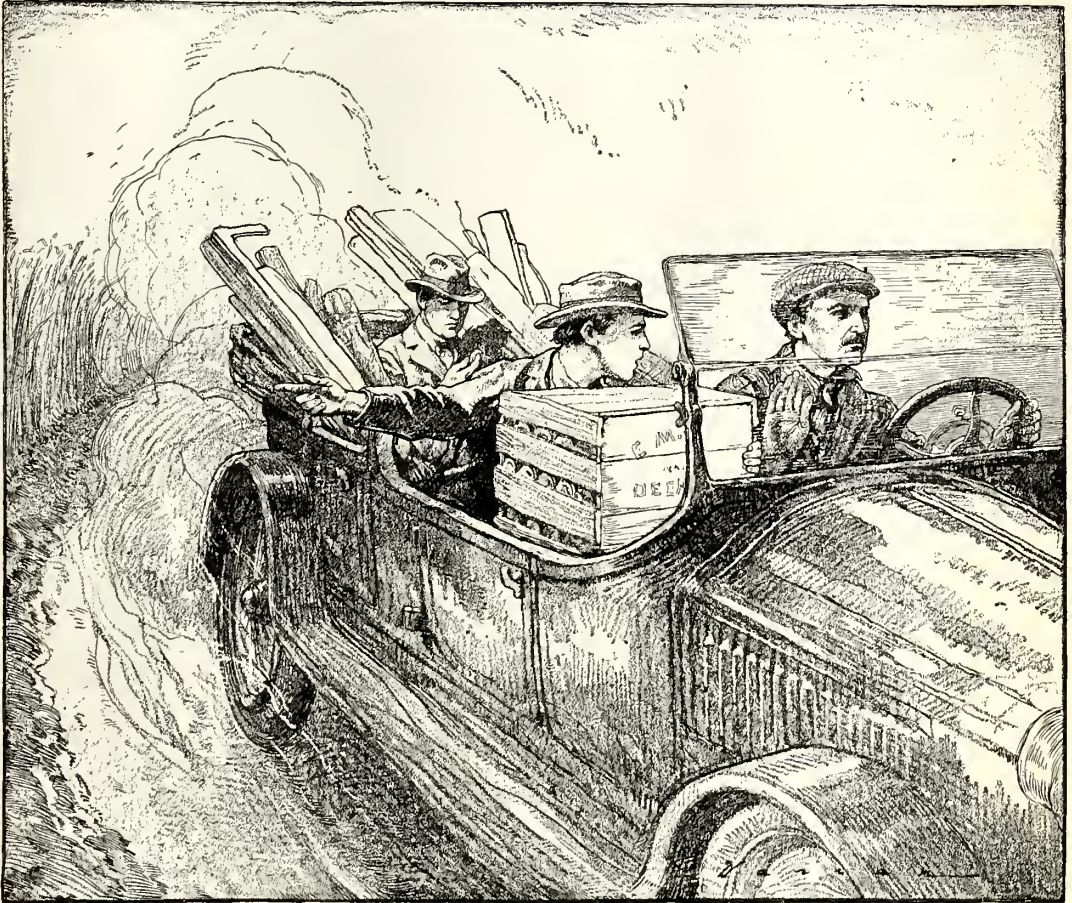

"PORTLAND IS NEVER GOING TO SEE ORCHARD BEFORE SEVEN IF WE DON'T STICK TO THE TRAIL"

so efficient that before long I found I was really in the way. It was at this moment the thought of the truant cattle recurred to me. I glanced at the shack. It was even nearer than when I had first spoken of it.

"I've a good notion to hop over there and warn them about that stock in the wheat," I suggested. "It's just a step. I'll be back before you're fixed up again."

"You'll find 'steps' rather deceivin' in this country," grunted Carter, over a wrench.

"If you go," clipped in Mr. Portland, with a squarer jaw than ever, "understand, you take your own chances. We shan't wait a second. You'll find your grip in that buck-brush—"

Distances proved deceiving, even as Carter had said. However, I made the grade, as I thought, in pretty fair time. Puffing and blowing with my run, I came upon a neat, brown-eyed young woman at the door of the shack and managed to make known my errand.

Rather contrary to my expectations, the brown-eyed person seemed not a whit sympathetic with my perturbations about either the crop or the cattle. Instead, she coolly reached a hand within the door, and, bringing out a very good pair of field-glasses, conned the landscape in a most matter-of-fact way.

"Yes," she remarked in an efficient tone,



"I sighted them not five minutes ago myself and 'phoned Mr. Miller. It 's his wheat—and stock too. Thank you very much, just the same," she added, as an afterthought, as she saw me returning to go.

Considerably crestfallen, I started running toward the trail again. I felt that the young woman's imperturbable efficiency had quite put my flustered haste to shame. My ardent effort had turned out anything but useful. In fact, it now seemed a trifle ridiculous. What could I tell the others?

Very soon it began to appear I would not be able to tell them anything, even should I desire. I had made but half the distance that lay between the shack and the car, when the roar of the starting engine droned to my ears. I experienced a throb of genuine dismay. With my heart pounding like a hammer from running, my muscles aching from drastic exertion of a very tired and hungry body, and the prospect of rescuing my grip from the buck-brush and finding my way through miles of unknown country, I felt my courage cooling very rapidly.

"You've sure made a mull of your chances!" I accused myself, with no little bitterness.

But as I at once observed that the humming automobile had not yet started, I renewed my pace, concluding that the good-natured Carter was delaying on my account. It was not until I had rolled breathless over the car door and the engine had sputtered ahead that I discovered what appeared to be a more potent cause for the delay. As I again scrambled under the box on the front seat, I noticed that a slat of its cover had

been loosened, the rent in the inside wrapping widened, and one of the bottles was bobbing helplessly, as if it had been hastily reinserted.

So Carter had taken advantage of my non-



"I 'VE GOT A PLACE THAT WILL FIT A CHAP HANKERING FOR RESPONSIBILITY!"

appearance to indulge in his fatal weakness! And the new anxiety of still more reckless driving was now to be added to those of a weak car, a lowering sun, and already one breakdown? And I, of course, I was the cause.

As this thought finally took possession of my mind, I caught myself involuntarily lifting my glance to Mr. Portland's face. His eagle-like eyes were directed full upon me,

snapping with anger, and his brows beetled and his chin protruded in a most alarming way.

"You young jackanapes!" he threw at me between his teeth.

I received the rebuke meekly enough. I now felt I deserved it. Uncle Tim indeed! What would he say to my pitting my judgment against older heads and causing important men to miss their trains?

Considerably humbled, I rode along in silence. In fact, everybody was silent. We tore, bumped, and rattled ahead, mile after mile, without a word. The grain-elevators along the other road were now visible, it is true, but still at a good distance, penciled like vague smoke-stacks on the sky rim. It was past six already, as I had discovered by a surreptitious glance at Mr. Carter's watch, as he held it for a moment in his free hand.

Once Mr. Carter waved an arm toward a group of buildings, intimating that there was where he thought a good harvest-hand was needed. But it would mean stopping the auto for a moment. This I implored him not to do. He was coming back this way, and what was one supper more or less compared to catching that train?

On we rushed, the red rose-pods and the buck-brush rattling against our very doors, past stretches of flying summer-fallow, of speckled stacks and grain yet uncut. We dashed over lumps and bumps and crept impatiently over corduroy-like road-beds elevated through half-dry sloughs.

And finally there sprang up before us, at a sudden turn, an elevator, mounting like a tower against the naked dome of the sky, while early red and green lights were twinkling in the offing. It was the G. N. R. And this was Orchard!

"I 'll carry your bag, sir!" I called, as Mr. Portland essayed to get on his benumbed feet. Carter had already run for the station. We met him returning to us at its door.

"She 's five minutes late!" he called out joyfully. "I 've set young Hunter writing off your ticket already. Look! There 's her headlight now."

I was just drawing a sigh of happy relief when a thumping clap came from somewhere on my back. Looking up, I discovered Mr. Portland, his eyes glowering piercingly into mine.

"Do you propose to look after other people's cattle as well as this man Miller's?" he demanded.

Feeling rather cheap, and not knowing what to say, I managed to say nothing.

"Because if you think you can, I 've got a place that will fit a chap hankering for responsibility. There 're a good many fellows hankering for the salary. But that is n't the part that interests me."

"But, sir," I protested, "I 'll have to confess I don't know anything about business—"

"You know a plowshare from a piece of binder, don't you! And when a farmer comes in for repairs, you know how to hunt the place over for the thing wanted, or help him to? The point is, will you have your eyes as open for my business as you did for Miller's?"

"I 'll serve you as well as I would Uncle Tim!" I said, with a great lump growing in my throat.

"Very well, Carter," he shouted, as the passing engine showered us with cinders, "take him back to Cadboro with you—you 'll be making your usual trip over, I suppose. Put him on the train for Wilders. There 's an office girl there will let him in the shop. I 'll be down next week."

---

## EVENING

By BARBARA POOLE

[Age 10]

WHEN the breeze is gently blowing,  
 When the sun has gone to rest,  
 When flowers close their colored cups,  
 When birds are in their nest,  
 When everything is quiet—  
 It 's the time I like the best.

When the hot day's work is over,  
 When the cool night shades draw nigh,  
 When dew has pearled the grasses,  
 When the stars have pearled the sky,  
 Then I see the moon,  
 The friendly moon sail by.



# THE MYSTERY AT NUMBER SIX

By AUGUSTA HUIELL SEAMAN

Author of "The Boarded-up House," "The Sapphire Signet," "The Dragon's Secret," etc.

## SYNOPSIS OF PREVIOUS INSTALMENTS

NOTHING could be much more mysterious than the discovery the cousins Bernice and Sydney Conant had made at the old, deserted phosphate-mine pool, Number Six, in the wilderness heart of south Florida. Who was the strange white child, calling herself Delight, who seemed to be in the care of the half-breed Indian guide of the Everglades, Jerry Sawgrass, and his "cracker" wife? She did not herself know; and, if Jerry did, he would tell no one, but kept her secluded from the world and ignorant of all but the years she had spent in the Everglades in his care. Once she had overheard a mysterious conversation about herself between Jerry and his wife, and found later some charred scraps of paper that seemed to relate to her. These she had allowed Sydney and Bernice to examine, under promise of strict secrecy about them; but when the cousins came back to the pool to return them to her the next day, they found the little old farm-house, where she had lived, empty and deserted. Suddenly, Jerry had decided to decamp, but where he had disappeared to in the night, with his wife and Delight, was something the two cousins could not fathom. They surmise that he has returned to the Everglades.

A New York lawyer who is staying at the same little hotel with them in the "phosphate town" of Jasper, supplies another link in the chain of mysteries. They have surmised, from various circumstances, that he is in search of Jerry and that Jerry is, for some reason, desperately afraid of an interview with him, to avoid which he has evidently fled back to the Glades. That night Mr. Tredwell himself proposes that they all go out the next afternoon and visit Number Six, as he has just ascertained that Jerry lives there and he wants to have an interview with him. Without disclosing to him the fact that they know Jerry and his family are no longer there, the cousins take Mr. Tredwell out to the mine-pool and watch him discover the truth for himself. They do not wish him to know of their connection with Delight, but suddenly, to their great consternation, he turns and asks them point-blank if they have ever seen a young girl about Bernice's age in the vicinity of the pool.

## CHAPTER IX

### CROSS PURPOSES

In the brief space of time before he answered, Sydney managed to keep his head and hastily review the possibilities. Delight had not, he considered, extracted any promise from them never to disclose the simple fact of their *knowing* her. The promise related mainly to the curious papers she had confided to them and to the history of her life as she had told it to them. Perhaps then there was no reason why he should not answer fully and truthfully Mr. Tredwell's query.

So while Bernice held her breath to the stifling point, he replied calmly: "Well, yes. As a matter of fact, we did see a—a young girl in and about the place. Also, there seemed to be a woman there. Perhaps that was Jerry's wife."

Mr. Tredwell ignored the latter side-issue. "You *saw* the girl!—and what was she like, may I ask? Did you ever get close enough to her to describe her?" His keen blue eyes seemed to bore into Sydney's very soul.

"She came around the pool to where we were," admitted Sydney. "She looked like an Indian at first glance—or a very dark cracker type—black hair, very tanned com-

plexion. But her eyes were quite beautiful, deep iris-blue with long lashes."

"Did she speak? Did she talk to you?" Mr. Tredwell probed still deeper.

"Why—er—yes. I was fishing and she was rather shy; but she got talking to Bernice and they had quite a conversation, I believe."

Immediately, Mr. Tredwell whirled around to Bernice. "What did she say, may I ask? How did she speak? Did she seem very—very ignorant?"

Bernice could have cheerfully scalped Sydney for thus involving her in the affair, but she replied bravely, "She seemed a very sweet little thing, gentle and shy and—and very attractive." Truth to tell, Bernice was somewhat irritated at this rather autocratic catechism and suddenly had a bold inspiration, so she ended with: "But may I ask why you are so interested in *her*, Mr. Tredwell? I thought it was Jerry you particularly wanted to see."

The effect on Mr. Tredwell of this sudden turning of the tables was instantaneous. "Oh, I—er—I—well, that is a matter I can't very well explain just at present!" he stammered. "To be frank with you, this matter is very—er—very involved. A legal difficulty—it would be—er—very indiscreet to discuss it."

For a moment he was silent, puzzled apparently as to how to proceed. He sensed the fact that the young people did not quite relish this cross-questioning, yet there were plainly admissions that he was still very anxious they should make. Sydney and Bernice said nothing and let him struggle with the difficulty without aid.

"There is one thing I should very much like to ask," he began again, presently. "Did she—did you, in the course of your conversation with her, discover what she was called—what was her name?"

The two young people glanced at each other in rather a panic. What was it best to answer to *this*? To disclose that, might be a decidedly damaging admission, especially if this man's intentions were not friendly. Yet how could they evade the truth? Sydney took the matter in his own hands.

"We asked her her name, when we told her ours, and she said she was called Dell, but that her real name was Delight."

The effect of this statement on Mr. Tredwell was very singular. His eyes opened wide for an instant, then he drew a sort of gasping breath and turned and walked off toward the pool. There he stood, with his hands crammed in his pockets, staring down into the limpid water, while the cousins eyed him uneasily and wondered what was coming next.

"Oh, are we doing *right*, Sydney?" murmured Bernice. "Ought we—to have told—so much?"

"Can't very well help ourselves. He has us cornered good and proper! But that was a great dig you gave him, Bernice! You quite bowled him off his feet for a minute. Don't worry about the thing. If I were only sure what his motives were, I'd know better how to answer. The trouble is, we don't know. We may be doing Delight a lot of harm, or we may be holding back when it's all for her good. I *wish* I knew. Here he comes back again!"

In the short interval of time Mr. Tredwell's manner had changed completely, and when he again approached them it was to take an entirely new tack. His manner was open and frank, but exceedingly firm.

"It may seem quite unwarranted for me to question you so closely," he began, "but there are reasons—the best of reasons—why I must sift this matter to the bottom. I—er—I,—do pardon me for this rather abrupt way of putting it,—I feel absolutely certain that there are aspects of this affair that you

are acquainted with and have not, for some reason, seen fit to disclose to me. Of course, I do not know why and perhaps have no right to ask. But you *would* oblige me very much if you would tell me whether you knew, before we came here to-day, that Jerry and the rest had—decamped?"

"Yes," admitted Sydney, manfully, "we did. But there—were—reasons why—why we felt we had no right to tell you so."

"Then you really *do* know more of this matter. May I inquire further if you know where they went—and by what route?"

Sydney drew a long breath. "That I—I can not tell you. I have no right!" I—we—have given a promise!"

"Not to *Jerry*, I hope!" flashed Mr. Tredwell.

"No—to—Delight!"

Mr. Tredwell appeared relieved at this admission. "I suppose I have no right to inquire, but I should very much like to know why she extracted that promise."

"I'm sorry, but I don't believe I can tell you that, either," replied Sydney, with some firmness.

"Then perhaps you would be willing to answer this: Do you know anything about this—child's relations with the other two she lived with. Were they—er—kind to her? Did she seem fond of them?"

"I think it is all right to answer that," agreed Sydney. "They were very kind to her, so I understand, especially Jerry. She called him Uncle Jerry, and said she was extremely fond of him. I do not think she felt the same toward the—his wife. They have only been married recently."

"Thanks. That at least gives me a new impression of things. May I inquire if you knew whether she—er—went away with them this last time—willingly?"

Again Sydney was obliged to hedge. This was very dangerous ground. "I—I can not tell you that!" he said firmly.

"I see," acquiesced Mr. Tredwell. Suddenly he changed his ground again, saying: "If I had a mind to, I think I could give you a little piece of information that would startle *you* quite a bit. On further consideration, I believe I *will* give it. Do you know this? Last Tuesday afternoon, you two sat in the east corner of the hotel veranda and had a long and animated discussion of this very affair, much of which I could not help but overhear, as my room is right at that corner. I had come back to the hotel in the early afternoon, not feeling



quite well, and lay down on my bed for a nap. After a while I woke out of a sound sleep and heard voices outside. I'm rather used to that, as my window opens right on the veranda and I'm forced occasionally to be an unseen third party to various conversations, much against my will. I tried to go to sleep again and not overhear what you said. But suddenly I caught the name Jerry and something about the Everglades; and then, I confess, I listened with all my ears, for it is of the utmost importance that I get to the bottom of this matter.

"Unfortunately for me, you spoke in rather low tones and I often lost quite important items. But I want to tell you very frankly that I gleaned enough to give me almost all the clues I need—*almost*, but not quite. I apologize deeply for having had to do this. I detest and despise the rôle of eavesdropper, but in this case, if you knew all the facts, I think you would say I was justified. I heard you, Sydney, announce that you were going to seek deliberately to cultivate my acquaintance, and I made the task easy, as I was equally anxious to cultivate yours."

He stopped short to mark the effect of his amazing disclosure. A bomb suddenly exploded in their midst could not have astounded them more. In a veritable panic of dismay, they gazed at each other. *Why* had they not been more careful! Why had they not realized that the hotel veranda was no place to discuss an affair so secret, that it might not be as deserted as it seemed! But there was no help for it now. One phase of the matter quite angered Sydney, and he demanded, in a tone of repressed annoyance:

"Why then have you kept *us* in ignorance of all this, since you have discovered what you did? Why did you not tell us right away that you had—overheard?"

"Turn about 's fair play!" laughed Mr. Tredwell. "You seemed determined to hold me off and pump me as hard as you could, without my realizing it. I determined I'd do the same and see what each could make out of it. But is n't it time we stopped working at cross-purposes? What is the advantage?"

"It is n't a question of 'advantage,'" answered Sydney, relaxing a bit. "Since you have been so frank with us, I may as well tell you that we have become deeply interested in the girl. She has confided to us as much as she knows of her history,

and I must say there seems to be a dark-brown mystery about it all somewhere. But she made us solemnly promise we would n't tell any one and we're not going to break our word. We don't want harm to come to her."

"If I were to assure you," began Mr. Tredwell, "on my word of honor, that no harm is going to come to *her* through my investigations, but only good, would it make any difference in your feeling about the matter?"

"Most certainly it would!" cried Sydney, brightening up; and Bernice nodded a vigorous assent. "Only—only I don't see how that's going to affect the matter of the *promise*. That'll have to hold good, no matter what the circumstances are—won't it?"

"Perhaps we can circumvent that in another way!" smiled Mr. Tredwell. "For instance, if I were to tell you a few things I overheard the other day, and you realized how much I knew, barring certain rather necessary details that escaped me, perhaps you might feel that it would not be violating her confidence to supply those details?"

"Well, I might have a try at it," volunteered Sydney, cautiously; "but I do not have to answer if I think best not to!"

"You're going to make a true lawyer!" laughed Mr. Tredwell. "I can see that right now. However, suppose I tell you that I understood from some of your remarks that this child Delight (and, by the way, I never caught her name that afternoon. It—it quite surprised me when I heard it!—this child had in her possession something—some journal or diary—that half gave her a clue to a mystery about herself. I gathered from what you said about it that it was something in the nature of a naturalist's notes, but I was still asleep, I imagine, while you were reading it. Am I correct?"

"Yes," acknowledged Sydney. "It can do no harm to admit that much."

"The notes themselves, I presume, you do not feel justified in showing me?"

"That is just what she made us promise not to do!"

"I see. Among those notes were there many allusions to—to the child herself?"

"Very, very few. What there were did not seem to—to throw much light on the mystery."

"The child herself does not know what they mean?"

"I don't believe she does. She thought maybe *we* could understand—make something out of the puzzle. But we could n't."

"Does this child Delight remember ever seeing any one around with them—with Jerry—in the Everglades?"

"She remembers Jerry's first wife—a Seminole Indian woman. Absolutely no one else."

"Ah! that's a point that is very important. Thank you for not hesitating to disclose it. One thing more. I have n't a doubt that Jerry has gone back to the Everglades. It's the only place where he's likely to think himself safe from me. I would very much like to inquire if, when this party left here, you had any idea what special route they intended to take? Perhaps the girl knew."

"No; to be candid with you, their departure was the greatest surprise to us. It must have happened the very night after Delight gave us the papers. When we went to return them next day, the place was deserted. Quite by chance we found a little note she had left for us, but she knew no more than we what route they would take. She bade us good-by, that was about all."

"I thought it rather singular," went on Mr. Tredwell, "considering what I knew of the whole affair, that you should be so willing to bring me here this afternoon. I did not realize that you already knew the birds had flown! But now I have a proposition to make. This Jerry Sawgrass must be traced—and followed. The matter is so important that I have decided to postpone other urgent business, that would have

taken me back to New York, and follow this up to the end. It is a matter that has long hung fire, in a legal sense, and ought to be settled at once. I am more than

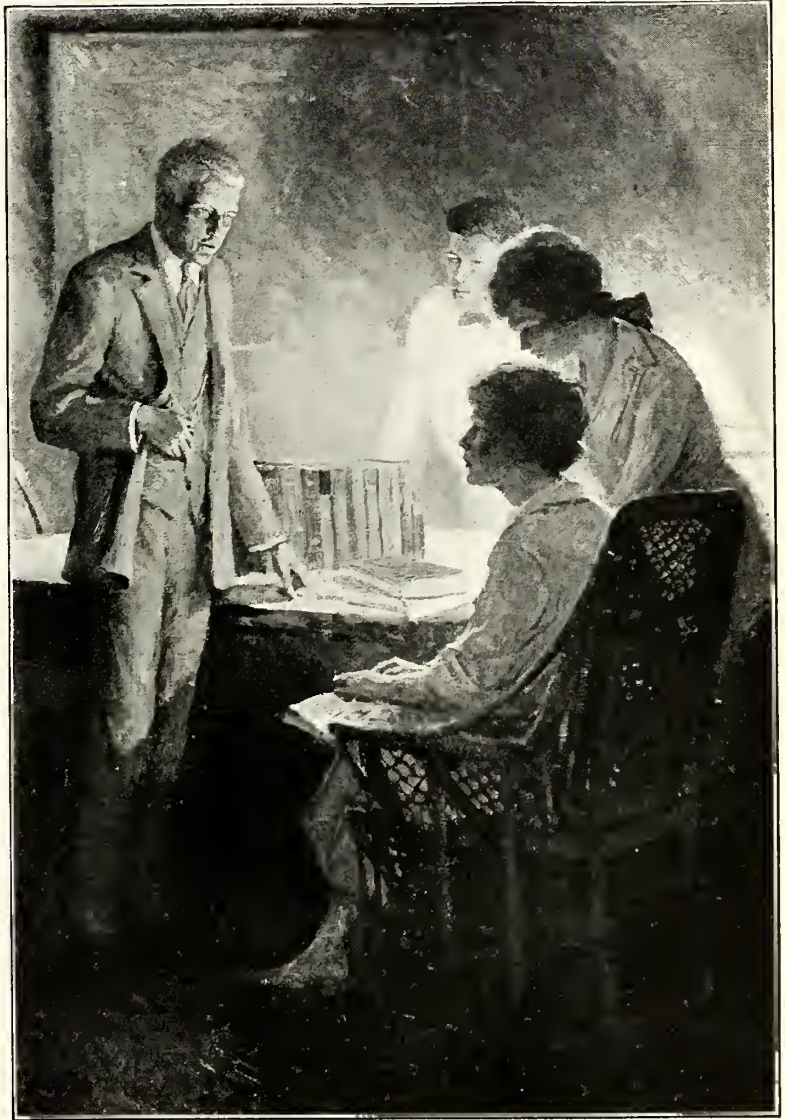

"THE MATTER OF THE EXPEDITION WAS BROACHED THAT NIGHT" (SEE NEXT PAGE)

fortunate to have come upon this clue. I had almost given up hope of ever solving the mystery.

"You two young people seem to have been lucky enough to gain the entire confidence of the principal actor in the drama. It is her welfare that is at stake, and Jerry is the factor that is blocking the whole proposition. Jerry we must get at, and, since you two are so deeply concerned with De-



light, how would this suggestion strike you? I invite you two and also Miss Bernice's mother to accompany me in my car (which I devoutly trust will be ready!) to take a few days' trip down into the region of the Everglades and see what we can discover in regard to the fugitives. What do you say?"

But the proposition was so astonishing, so beyond anything they had ever expected to happen, that they were both struck dumb. Their looks, however, were so eloquent that Mr. Tredwell laughingly remarked, "Well, as silence is usually construed to mean assent, I take it that the matter of the trip is settled!"

## CHAPTER X

### THE PURSUIT

THE return to the hotel was accomplished rather in a daze, as far as the young folks were concerned. It had been a bewildering afternoon, and the culmination had so taken their breath away that they were still incredulous that they could possibly have heard aright.

"I suppose, considering the circumstances, that it would be just as well not to acquaint Mrs. Conant with all our reasons for taking this trip, in case she agrees that you will all accompany me. It would be rather hard to admit another to share in this secret, and I do not see any objection to arranging things as if every one, except myself, were merely on a pleasure excursion. We will start day after to-morrow, if all goes well with that car of mine; and meantime, Sydney, you and I had better scout around and see if we can unearth any clue as to the direction the party took in making their escape. It ought not to be impossible to trace a trio as conspicuous as they would be—and in a mule-wagon, too. If it had been a car, now, the matter would be far more difficult. I would also advise that you bring along with us those papers Delight confided to you. I will not ask to see them till there is good and sufficient reason to do so and when you all agree that I am justified in having them shown to me."

The matter of the expedition was broached to Mrs. Conant by Mr. Tredwell himself that night. Owing to the fact that he had been a friend of her father, she was the more easily persuaded. And, added to that, a trip down through Florida in Mr. Tred-

well's luxurious car was a treat that no one could look upon without favor, especially as the life in a little phosphate-town hotel had long since begun to pall. To the great delight of the cousins, she gave her consent, and preparations for the excursion at once began.

The following morning was spent by Mr. Tredwell and Sydney, in the latter's car, in exploring all the region within the radius of a score of miles, striving to unearth any trace of the trail the fugitives had taken. It was, in the main, without any definite result. Several days had elapsed since the flight. More than that, as the earliest stage had doubtless been accomplished long after nightfall, probably few would have noticed a mule-wagon with its party of three—mule-wagons were not at all uncommon, even traveling after dark; and Sydney suggested that, in all likelihood, Jerry had clung in the main to unfrequented and poor roads and so kept out of sight.

Mr. Tredwell suggested that perhaps the owner of the old farm-house might afford them some clue, so they ascertained his name and hunted him up. He proved to be a doctor who lived in a near-by town. He acknowledged that the land on that side of the pool and the old farm-house belonged to him, that he had rented it to Jerry (who had given his name as "Mr. Simpson"), had been paid a month's rent in advance, and had heard nothing more of his tenants. He was surprised beyond measure to be told that they had gone. He knew nothing about who they were or where they had come from. He admitted that the old house was very dilapidated and that he had not expected to rent it at all, but was contemplating having it torn down when Jerry applied to hire it and establish his family there; and as he did not seem to object to its condition or require it to be repaired, he (the doctor) was only too glad to be able to rent it so easily.

There was no useful information to be gained in that direction, so the two turned their attention to another. They drove out to Number Six and examined critically every trail that led from the old farm-house, hoping to see, perhaps, the mule-tracks or the wagon-ruts left by the cart. But a heavy rain the night before had washed away every trace of recent marks, and left the two investigators as much at sea as before. At this point, Sydney and Mr.

Tredwell sat down on the edge of the dilapidated veranda to think it out.

"We might as well boil it down to its simplest form," decided Mr. Tredwell. "After all, whatever route he may have taken from here, Jerry's destination was the Everglades. It's only a question of the point at which he planned to enter. Let's reduce the thing to its smallest number of possibilities. We're over near the west coast. He would hardly, then, plan to take the long trip over to the east coast and enter by the routes in from there. The quickest and safest for him would, of course, be the nearest. Granted then, that he decides for the west entrances. If he pursued the usual course, Fort Myers, the Caloosahatchee River, and so forth, he would realize that he could easily be traced. He would undoubtedly try for a course farther in. He might even get over to the Kissimmee River, abandon his mule-cart, and go down the river by boat or canoe, through Lake Okeechobee in the same way, and so strike into the Glades from the north. Perhaps, looking at it from all sides, that is what he would be most likely to do. It would be the safest from observation. In any case, his progress is sure to be slow, unless he abandoned everything and took a train, say to Moorehaven on the Lake. But this, I'm certain, he would not do.

"Our best bet, therefore, is to get down, as speedily as possible, to Lake Okeechobee, and see if we can head him off there. His traveling will necessarily be very slow. In all likelihood, too, he will have to stop and get supplies at the southern end of the lake, before he enters the Glades. There's where we'll catch him. I propose, then, that we run over to the east coast and down as far as Palm Beach, striking in from there to the lower end of the lake."

"But is n't that going a long way around?" questioned Sydney.

"There's an old saying, 'The longest way round is the shortest way home!'" laughed Mr. Tredwell. "It applies particularly in this case, because the roads are better on that side and we can make quicker progress. Jerry, I figure, is ambling slowly down the Kissimmee River and keeping as much as possible out of sight. It will take him, at the very least, a week to reach the southern end of the lake, probably longer. If we push it, then, we'll be liable to reach the place long before he does, and welcome him when he gets there. I have ordered

the car to be ready at eight o'clock sharp to-morrow morning, and we ought to reach Melbourne, on the east coast, long before dark. By the next night we will easily have reached Palm Beach and can strike in from there."

So they arranged the matter and returned to the hotel. They had no sooner reached it than Bernice hurried to meet them and drew Sydney aside with an air of obvious mystery.

"What now?" he demanded, perceiving that she was boiling over with the desire to impart some news. "Anything interesting turn up?"

"Oh, Syd—you'll never guess! I've struck a clue, all by myself!"

"Good work! Let's hear what it is. If it's anything worth while, we ought to tell Mr. Tredwell."

"'Worth while' indeed!" sniffed Bernice. "It's about the worth-whilest thing we've found out yet. I've a great mind not to tell you—you're so snippy!"

"Oh, come off!" laughed Sydney. "You know what I mean! Goodness knows, we're in need of some clue—anything to give us a start!"

"Well, here's how it happened. Mother needed quite a number of little things for the trip,—things you can't get here,—so I took the bus over to Bartow to do a little shopping for her. While I was strolling about the town, waiting for the time for the next bus back, I happened to pass the place where the bus down to Arcadia starts. There was a big crowd getting in, and I had got almost by when—what do you think?" She paused exasperatingly.

"If you don't go on—double quick—I'll—I'll—" threatened Sydney, vaguely but menacingly.

"All right—all right! Well, I saw some one getting into that bus who looked strangely familiar. I could only see her back and she had a hat on. But something about her made me just stop short—and stare! Just before she got inside, she turned around to free her skirt, that had got caught on a nail or something—and—it was—the cracker woman!"

This time Bernice was thoroughly satisfied with the effect of her disclosure. Sydney grabbed her by the elbows and demanded excitedly:

"What?—not the cracker woman! You can't mean it!"

"Most assuredly—the cracker woman!"



mimicked Bernice. "No other. I could n't mistake her, even though I only saw her once. She was the last one in, and the bus started right off, so I had no chance to speak to her. But that 's my harrowing tale!"

"Golly!" ejaculated Sydney. "Where 's Mr. Tredwell?" and he was off before Bernice could get in another word.

This sudden and very fortunate discovery changed their entire program. If Bernice were not mistaken (and she declared she could not be), their wisest course was to pursue the cracker woman and not Jerry, so Mr. Tredwell decided. Why there was this strange split in the fleeing party, no one could guess. But since Jerry's wife had, in the one interview the cousins had had with her, been the most inclined to communicativeness, common sense pointed out that she was the one to pursue. Moreover, her route they could trace with a fair amount of accuracy.

"There 's not a moment to be lost!" cried Mr. Tredwell. "My car is ready now. I 've just been to the garage and found they had finished with it ahead of time. Let 's get dinner as quickly as possible and make tracks for Arcadia. We won't wait till to-morrow to start. Can you get your mother to fall in with this change of plans, Bernice?"

"Oh, I 'm sure of it! Mother is really all ready now. I 'll run up and pack our grips right away."

They had no definite plan as to just how they were going to trace Jerry's wife when they did get to Arcadia; but as they went bowling along in Mr. Tredwell's high-powered car that afternoon, he gradually worked out his scheme.

"My idea is to overtake the bus before it reaches Arcadia, if possible," he confided to Sydney, who was sitting beside him. "Of course, it has a big start on us, but it has to stop at all the towns in between, and we *may* be able to catch up with it. I do wonder what this woman's object was in coming over this way?"

"The only reason I can think of is that, as some one said she came originally from down Fort Myers way, perhaps she 's suddenly made up her mind to go back there for a time," replied Sydney.

Mr. Tredwell agreed that this could be about the only reason for the unexpected move on her part. They drove on, at what seemed to Bernice's mother a reckless pace,

and she more than once turned to her daughter to remark that she had not supposed Mr. Tredwell so inclined to break the speed laws. Bernice, however, who was holding her breath and watching the road ahead with fixed attention, declared, on her part, that they did not seem to be going half fast enough!

Town after town they drove through, always stopping to inquire if, and how long before, the Arcadia bus had passed that way. One other surmise troubled the three, and that was whether the object of their pursuit had got out at any one of these intermediate towns. But as Mr. Tredwell confided to Sydney, if she had, the only way to find it out was to overtake the bus before it got to Arcadia, follow it into that town, and note whether she was among the passengers. If she were not, they would know that she had left it earlier in the journey, and then it would be necessary for them to trace her back.

The golden afternoon sunlight at last began to wane. At Wauchula they learned that the bus had passed through three quarters of an hour before, which was a decided gain on the time at the last town. On they sped, the big motor purring rhythmically, the speedometer registering thirty-five to forty miles without intermission, except when they slowed for some sharp curve or passed another car on a narrow bit of road. At Gardner they were but twenty minutes behind the bus, and, as Mr. Tredwell remarked, were bound to catch up with it before it got to Brownville, when—there was an ominous veering of the car to the side of the road. Mr. Tredwell applied the brake and brought the machine to a stop. And to the excited inquiries of Bernice who was sitting in the back seat, Sydney had only one bitter comment:

"*Flat tire!*"

It took twenty minutes to change to one of the spares, which was, as Sydney remarked, a record for such a heavy car and a rear tire at that. But he whispered to Bernice that they had now probably lost the chance of getting in ahead of the bus, as they were a good forty minutes behind it, and likewise their best opportunity of tracing Jerry's wife, as they could not then be certain whether she had got off at one of the intermediate towns or had gone on by the next bus to Fort Myers. It was an exasperating accident.

At length all was in readiness once more, and they made another start. But the hope that had been so near fruition was now pretty well abandoned, and the best they could expect was to reach Arcadia before the time for a bus to leave for Punta Gorda and Fort Myers. If Jerry's wife was intending to make the latter point,

slid over, in some incomprehensible fashion, and lay with her side wheels in a deep ditch. No one was hurt, miraculously, except the driver, who had a sprained wrist. He tried to explain excitedly how he had done his best to pass a car that insisted on crowding him badly, and his right wheels had gone into the ditch before he could



"MR. TREDWELL BEHELD THE OBJECT OF THEIR LONG CHASE—JERRY'S WIFE!"

she might have to wait about till bus time and so be in evidence. But it was a rather forlorn hope.

Suddenly, at a turn in the road, Sydney looked ahead and shouted, "What 's that?"

It seemed a queer affair that they were approaching. A crowd of people appeared to be standing about in the road, and over at the side, keeled over into a ditch, was some great, bulky object whose form at first could not be distinguished from the car.

But as they got nearer, Sydney gave an astonished whoop! "*The Arcadia bus!* She's gone over into the ditch. Hope no one's hurt!"

It was a curious scene that they reached a few moments later. The big bus had

turned out. How the passengers had managed to extricate themselves was a mystery no one tried to explain. But there they stood, surveying the results with disconsolate patience and waiting for a relief bus, which was to come from Arcadia presently. The accident had occurred in the midst of a wooded stretch, wild and uninhabited, with "soup" (as Sydney called the boggy land) on both sides in the dense undergrowth.

Suddenly, Sydney, who had been searching through the groups of passengers with a keen eye, turned to Mr. Tredwell and whispered: "Over there, to your left, sitting on a log! Look!"

Mr. Tredwell did as he was directed, and beheld the object of their long chase—the cracker woman, Jerry's wife!

(To be concluded)



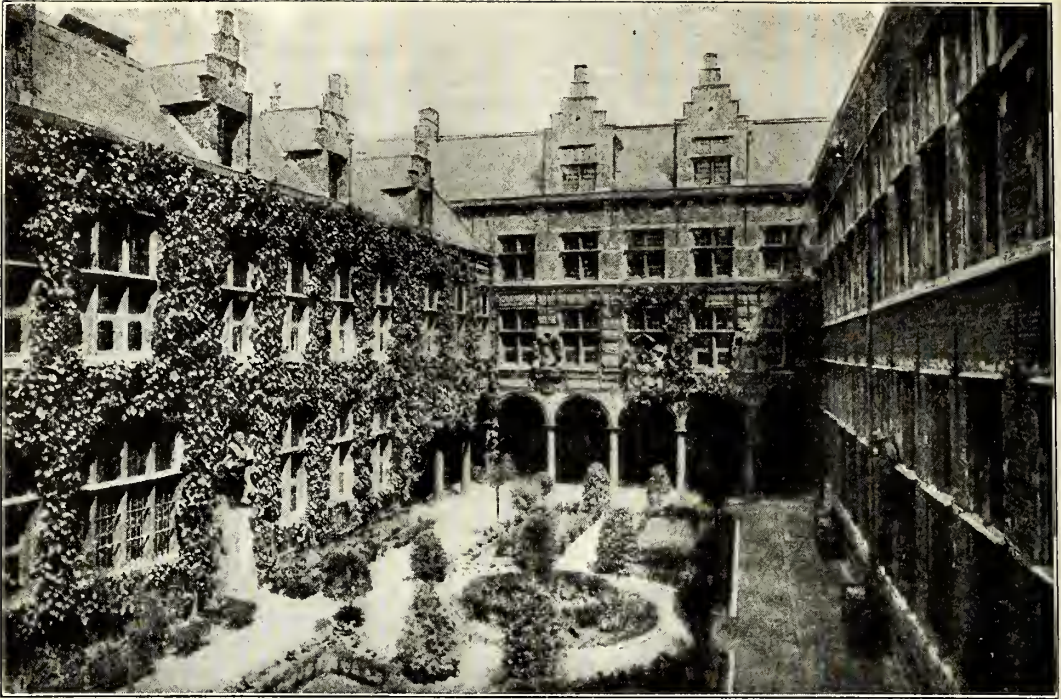

THE BEAUTIFUL INNER COURT OF THE PLANTIN MUSEUM

## THE OLDEST PRINTING ESTABLISHMENT IN EXISTENCE

By HARRY TUCK SHERMAN

WHEN we turn over the pages of ST. NICHOLAS each month, how often do we stop to think what we owe to the art of those who printed them, or what printing has done to civilize the world? Does it ever occur to you to think what we should be doing to-day if we had no printed, but only hand-written, books from which to get all our knowledge? We should indeed still be in the age of darkness, of ignorance and superstition. The publisher, the editor, and the printer are now just ordinary individuals of our everyday life, to whom we are so accustomed that we never think of their worth to society. And yet they teach the baby his first letters, the school-boy his first lessons. To them the business man appeals, through the daily newspaper, as soon as he is out of bed in the morning. Surely, we feel too little the debt of gratitude we owe to the printer, his industry, and his art.

In the time-honored old city of Antwerp, which, as you know, was the home of the

great painters, Rubens, Van Dyck, and Teniers, there stands to-day in an unaltered condition a lasting monument to the invention of Gutenberg—printing. It is the oldest existing printing and publishing establishment in the world, and one which has played a leading part in the history of the printer's art and of the progress of the world's civilization. It lived through all of those trying days of Spanish domination, and thus stood a witness to the great struggle for religious toleration. In the beginning, it could issue no books not approved and sanctioned by the religious authorities, and it lived to enjoy the fullest liberty of the press, which, as you know, is one of the triumphs of the people's struggle for freedom.

For three centuries the steady thump of presses and the tread of busy feet echoed and reëchoed through the long corridors, up and down the stairs, in the connected buildings which formed what was known as "The Sign of the Golden Compass." For three



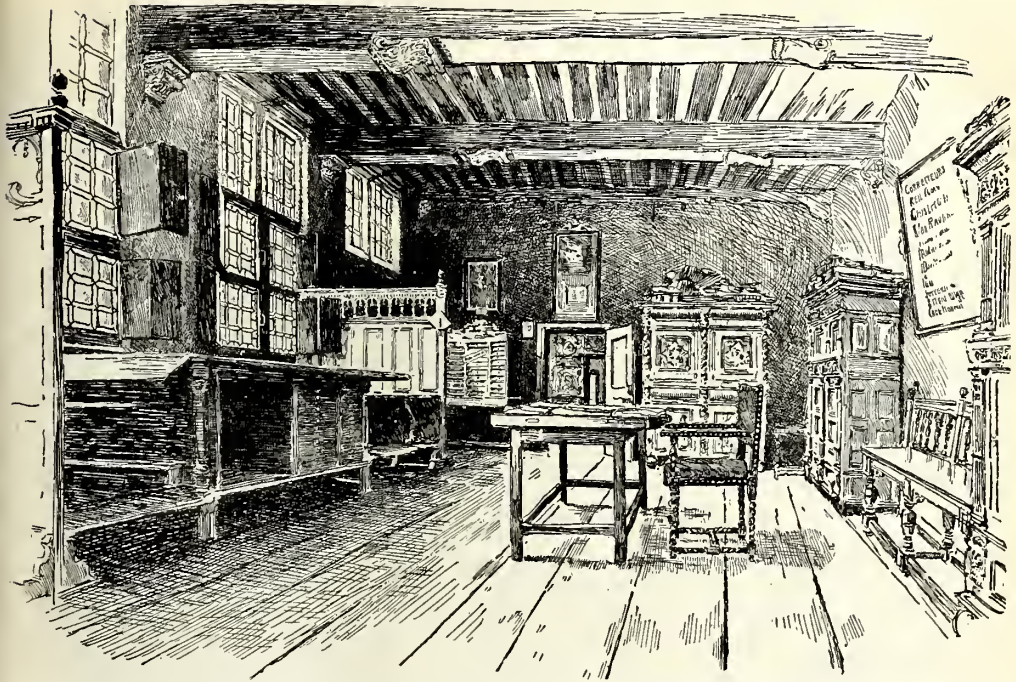

THE PROOF-READERS' ROOM, USED AS SUCH FOR THREE CENTURIES



ONE OF THE EDITORIAL ROOMS IN THE PLANTIN MUSEUM



hundred years the "illustrious printer" Christopher Plantin and his descendants carried on one of the most prosperous printing, engraving, and illuminating establishments in Europe, Christopher Plantin founded the house in 1555, and it was not until his direct descendant, Edward Moretus-Plantin, sold the buildings to the city of

was suspected of printing forbidden works. An order was given to have The Golden Compass searched, but no proof was found against him, and he was not again molested. Two years later his reputation was made, and he became famous throughout Europe, for King Philip II, of Spain, was then his best customer and, by his orders, Plantin pub-



"IN THE PLANTIN ESTABLISHMENT, THE PROOF-READERS WERE NOTABILITIES"

Antwerp, in 1876, with all their material, the library, collections, etc., that the presses ceased their work and the voices from the printing-rooms were hushed.

There probably never lived a more renowned printer than Plantin, who is claimed by the town of Tours, in France, the records of which show that one Christopher Plantin was born in a near-by village in the year 1514. After working as a book-binder and printer in France, he registered at Antwerp in the corporation or guild of St. Luke, in 1550, with the title of "Printer and Burgher." The first book bearing the stamp of Plantin's house, in 1555, is "The Education of a Young Woman of Noble Birth."

In 1556, we learn, the printer was in trouble. The country was under the heavy cloud of the Spanish rule, and, from the mere fact that he was a publisher of books, Plantin

lished the "Royal Bible" in five languages, a work which proved the most important ever undertaken or accomplished by any printer up to that time. Plantin was then commanded to print all church books for Spain and her dominions, and finally King Philip procured for him the privilege of printing for the Pope, which monopoly for The Sign of the Golden Compass proved to be the key to the prosperity of the family. It was not until 1801 that the Spanish dominions finally withdrew their monopoly from the establishment.

To wander slowly through the rooms and galleries, through the sleepy courtyard of this quaint and picturesque home of a well-to-do burgher of the sixteenth century, is to go backward on the tide of time for three hundred years. One wishes he might be dressed in doublet and hose, a feather in his cap and



a sword by his side, to be in harmony with his surroundings. In the press-room, one is still more forcibly carried backward, and, in imagination, the place peoples itself with busy workmen; the click of the compositor's type and the thud of the presses seems to become audible; there is a hurry and a bustle and a picturesque disorder. Suddenly, through the long corridor, coming from the direction of Plantin's study, we hear the murmur of voices, then the rustle of silken garments, and lo! King Philip himself, accompanied by his suite and the printer, enters the workshop. They vanish. Again, there is a rattling of arms, the sound of more boisterous voices, and Na-

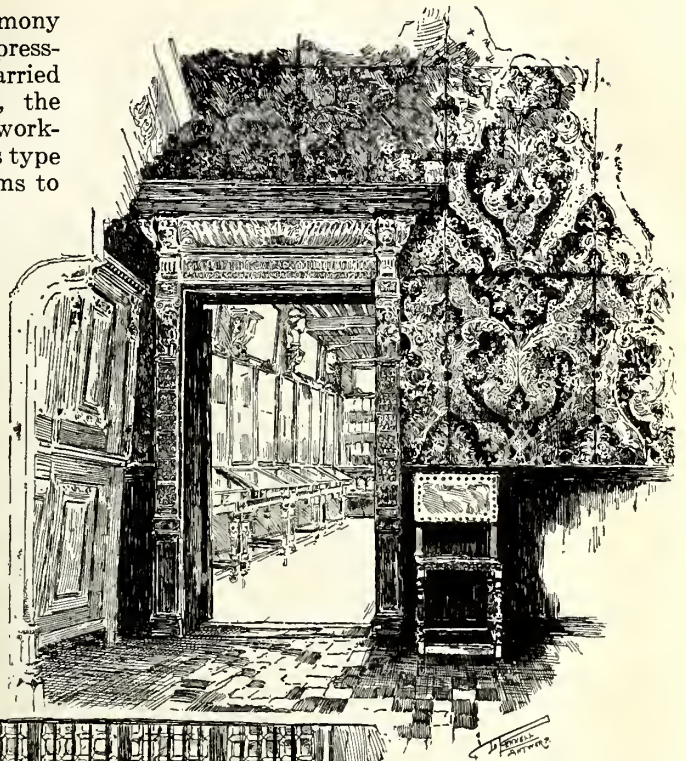

ENTRANCE TO THE ENGRAVING ROOM, IN BLACK AND GOLD

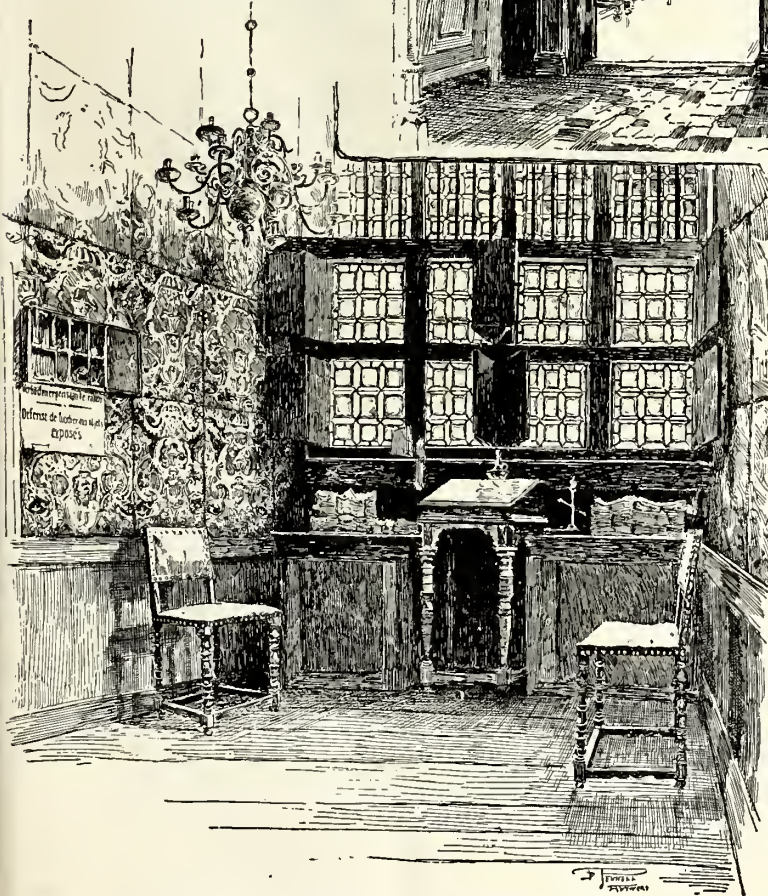

THE PRIVATE OFFICE OF CHRISTOPHER PLANTIN

oleon the Great, with his generals, accompanied by one of Plantin's descendants, visits the printing-house and himself turns the very

press that Christopher Plantin worked. We dream on in our fancy until we are roughly awakened by the sudden entrance of a party of tourists, whose clamor and indifference proclaim their absolute ignorance of the sacredness of the place. Not only was The Sign of the Golden Compass a printing-house, but the Plantins were the finest engravers of the period. The great artists Rubens, Van Dyck, Jordaens, were not above working for them, and keenly interesting are the bills for designing sent in by these famous painters. The collection of their water-color designs is of immense value, and the sketches made by Rubens for the



engraver are legion. There are designs for illustrating purposes, for illuminating, for frontispieces, each one a priceless work of art. The manuscripts from which Plantin did his first work are preserved intact as in the days when they were used.

But the little, quaint shop is what most

church publications, for in those days the prices were fixed by the magistrates and books could be sold only at that tariff. In the counting-room hangs the list of "Forbidden Books," among which, curiously enough, are two published by Plantin.

Nowadays, in a busy printing-office, proof-

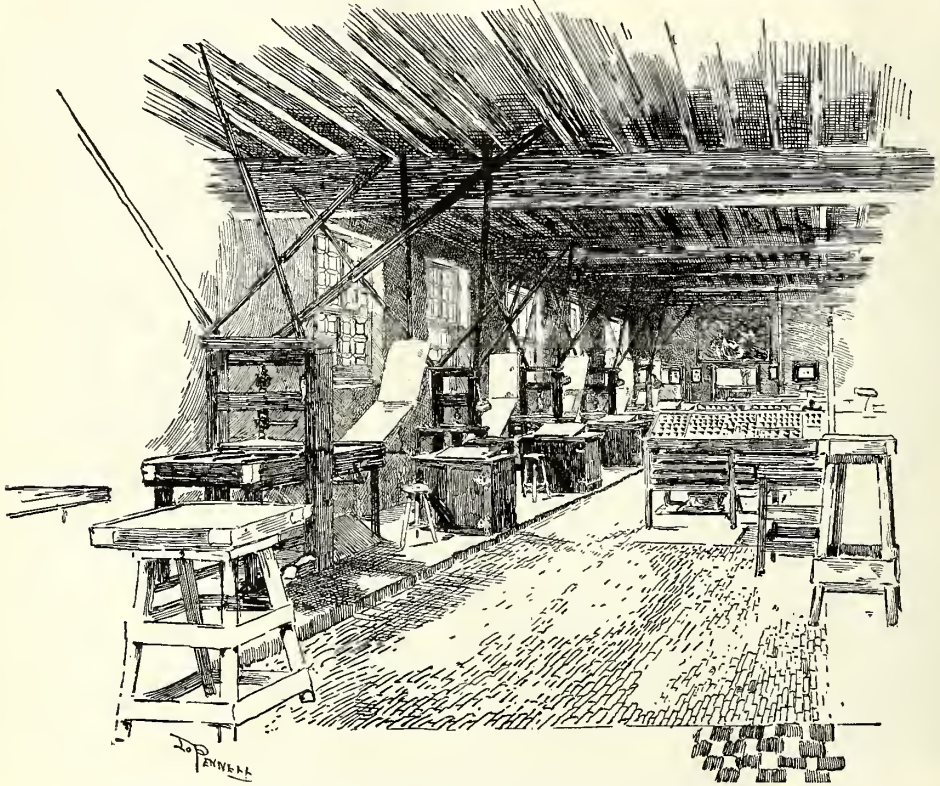

THE PRESS-ROOM, WHICH CONTAINS TWO OF PLANTIN'S ORIGINAL PRESSES

interests the younger visitors. Here the illusion is complete, and there is a stillness about the place that makes one hesitate to speak, for fear of raising the ghost of some sixteenth-century attendant, or call forth the shade of Plantin himself behind the very counter over which he served his customers three centuries ago.

Everything here in this sixteenth-century book-store is in its place, as if ready for the day's work, and we can easily imagine some matronly Dame Plantin handling and weighing out her coin at the window between the shop and the counting-room. On the shelves, rows of books are exhibited. The sales-book lies open on the small desk at the end of the counter, with the amount of the last sale entered. Behind the bookkeeper's chair hangs the calendar for the year 1593, and on the wall the price-list of school and

reading may be done on the end of a deal table, on the metal slabs used for setting forms, in any out-of-the-way corner or makeshift spot to be found at the moment; but, in the Plantin establishment, the proof-readers were notabilities, and not far from the little shop is the proof-readers' room, which served the same purpose for three centuries without a break. The principal piece of furniture here is an enormous, massive oaken table standing against the wall under the vine-framed windows, and in front of it is a great screen or partition of oak for the comfort of the readers, to keep off the draughts and to serve as a back to the bench on which they sat. At each end of the table is an adjustable leaf or desk. Large oaken chests and cabinets full of manuscripts and proofs and an old arm-chair complete the furniture. The chests and cabinets contain unbound leaves,



some of which have been corrected, while others are awaiting their turn, as if the workers were only out for their midday meal.

Leading from the proof-readers' room is a smaller one about ten feet square, the private office of generations of the same persevering, laborious family. It is in this room that business was transacted with King Philip himself, and where the dignitaries of the church and of many states were frequently received. The walls are covered with rich leather, heavily gilded, while the pigeonholes, with their files of documents relating to the current work of that remote period, remain undisturbed.

Upstairs, curiosity leads us to Plantin's bedroom, still furnished with the cold, oaken severity of those distant days. Then we go to the attic, where is located the original type-foundry, quite unchanged. This comprises two rooms furnished with the utensils and implements of the typefounder, all of which are in their original places ready for the day's work. There are the vises, the molds, the file, the dies, the new type, and the old ready to be remelted. The furnaces, crucibles, ladles, everything is in readiness

for the work which never begins, however, for we are quite lost to the fact that it is all now a museum very cleverly arranged to give the illusion of suspended activity.

Downstairs again, we go into the press-room, where stand two of Plantin's original presses, which differ but very little from the screw-presses used up to the beginning of the nineteenth century. From the press-room we pass out into the busy street and awaken to twentieth century reality.

The tide of travel from America to Europe runs toward Antwerp, as it does toward other great ports, and many visitors to that historic city leave it, ignorant of the fact that such a gem of antiquity exists. No boy or girl, man or woman who spends a day in Antwerp should fail to visit this vivid scene of burgher life in the sixteenth century, the impression of which is indelible. To write of all its treasures, of its valuable paintings, its carvings, specimens of engraving, of the architectural value of every beam, door-knob, window-pane, and latch-key would fill a volume. It is a priceless possession, unique and without a rival, worthy to be ranked among the first art treasures of the world.

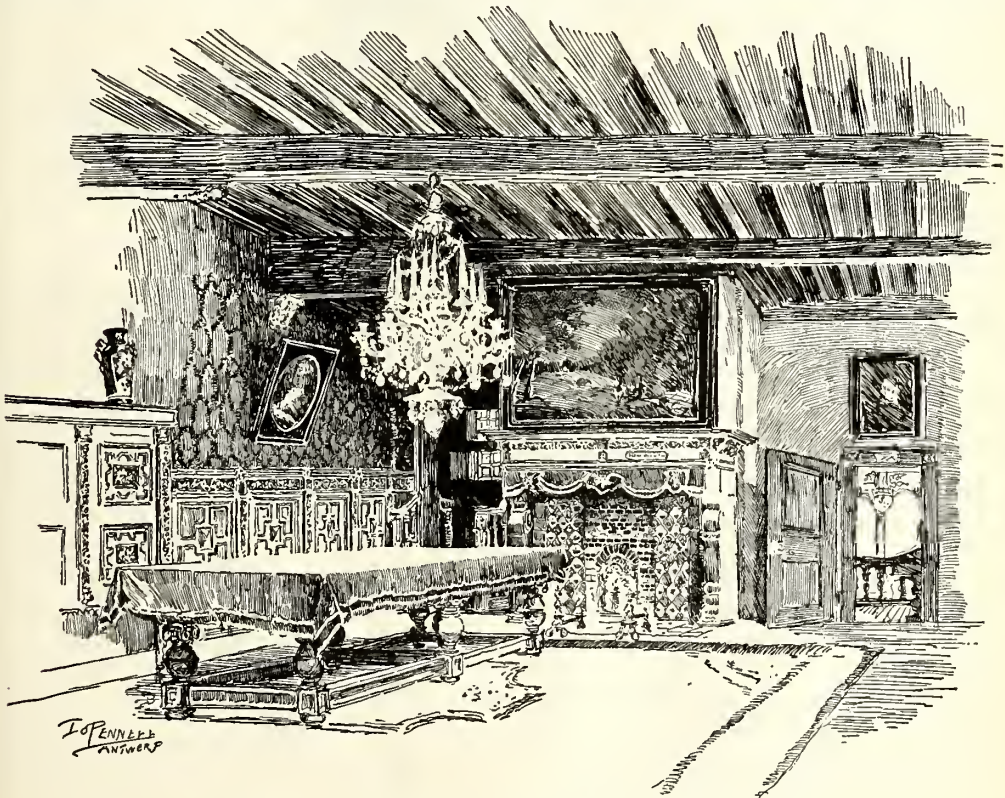

THE ROOM IN WHICH THE PROPRIETORS MET FOR CONFERENCE



# The Princess Alone

BY SHERLOCK B. GASS

ILLUSTRATED BY DOROTHY HOPE SMITH

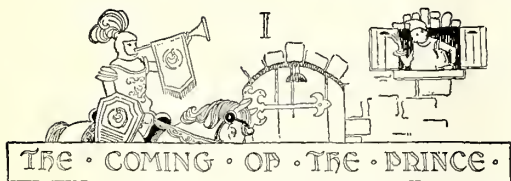

THE prince was coming—the brave young prince of the neighboring kingdom. A horseman, all clad in scarlet and gold, came galloping down the cobblestone street and stopped in the market-place.

“The prince is coming!” he shouted, and galloped away.

Soon the whole city was on tiptoe with joy, for the prince was young and fair. And it was whispered that before he should go back to his own kingdom he might choose for himself a wife.

In the great castle the king’s daughters knew that the prince was coming—and why he was coming. They jumped out of bed in joy and began to comb their yellow hair in the sunlight. Then the Princess Peas-blossom said to the Princess Clover:

“Shall we tell the Princess Alone?”

And they both laughed.

Now the Princess Alone lived by herself in the top of a high tower of the castle wall. And this morning she slept very late. She had been weeping all night, for her father and mother were dead, and her aunt the queen was unkind to her. Her uncle the king loved her, but he feared to be kind. That was why she lived by herself in the top of the high tower, with but one old servant to wait on her. And this was why she was called the Princess Alone.

The Princess Alone slept on in her high tower. Eight o’clock came, nine o’clock, ten o’clock, and a ray of sunlight fell upon her face. Up she jumped, and just as she put her foot upon the floor a bugle sounded at the castle gate.

She forgot her sadness and flew to the balcony. Down in the courtyard below she beheld a great company of horsemen, gay with spears and banners. And there

in the midst of them on a snow-white horse was the prince of the neighboring kingdom. Joy came into her face, for she saw how brave and happy he was.

Then the prince looked up and saw her, bright and fair in the morning sun. He stopped and gazed, and then bowed low over his horse’s neck.

Now the Princess Peas-blossom and the Princess Clover were on their own balcony. But the prince did not see them at all; and they were angry and went to their mother.

“Oh, Mother!” said the Princess Clover, “the prince did not see us at all. The Princess Alone came out on her balcony, and he saw only her.”

The queen kissed them and said, “Never mind, my dears, he shall not see her again.”



A GREAT feast was spread that day for the prince. When it was over, the king, as the custom was in those days, gave him the great keys of the castle and told him he might go wherever he chose. And the prince departed.

He cared nothing for all the rest of the castle, but went straight to the high tower, climbed the winding stairs, and unlocked the great door at the top. The room was very dark. He stood still and listened, and as he listened he heard some one breathing quickly, as though in fear.

“Oh, princess,” he said gently, “do not be afraid.” He heard a sigh in the darkness. “Who are you?” he asked; “and why were you not at the feast?”

“I am the Princess Alone,” she said simply, “and when I would have gone to the feast I found the door locked and the windows barred. I did wish to go to the feast,

for there came a prince to the castle to-day, and he was young and kind and brave, I know. For I saw him when he came, and I could have loved him. But here there is no longer any one who cares for me."

All this time the princess did not know that she was speaking to the prince himself.

"Poor little princess!" murmured the prince; "you make my heart sad. But perhaps it was well that you were not at the feast to-day. And I will tell you why. For if you love the prince, the prince loves you as well. He saw you on your balcony when he rode into the courtyard this morning and his heart went out to you. And he would like to go home to his own kingdom to-morrow and say to his father, 'Father, I need not go on with my journey, for here in the very next kingdom is the Princess Alone, whom I love. I wish to make her my wife.'

"But, dear Princess, mark this well—the prince may not choose whom he wishes for his wife. It is an old law in his country that the prince must journey abroad and seek far and wide for a wife who is a princess indeed, but one who knows and understands all sorts and conditions of men. She must have sympathy, and wisdom too. She must know the beggars and the butchers, and lords and ladies, and tinkers and sailors and all manner of people, rich and poor, high and low.

"And then in a year, after he has come home, all the princesses who wish it, may come to his father's castle and there be

judged in a great trial. And the princess who has the greatest sympathy, and also the greatest wisdom, will become his wife and his queen." For a little time they were silent in the darkness.



"THEN THE PRINCE LOOKED UP AND SAW HER"

"And now, dear Princess," he went on at last, "the heart of the prince will be sad. For though he knows that you have sympathy for all sorts and conditions of men, yet he fears that you do not understand them. How can a princess that lives alone in the top of a high tower know fishermen and shop-keepers, and soldiers and players



and shepherds. It is hard for a princess to grow wise.

"None the less," he continued, and there was a sound of hope in his voice, "at the end of a year, if you still love the prince, you shall come to his father's castle and take part in the great trial. But oh, little Princess! the prince's heart is sore, for indeed he loves you dearly."

And still the princess did not know who the stranger in the dark tower-room was.

"Kind sir," she said, "what you tell me has made me very sad and yet very happy. I know that I am not wise. I know nothing about tinkers and jugglers and soldiers and travelers. Yet I wish to thank the prince for his love. For indeed I am very lonely and have no one else to love me."

The prince turned, and, seizing the bar that locked the shutters, twisted it till it broke. The shutters flew open and the light streamed in. When the princess saw who was before her she gave a little cry, and trembled, half with fear and half with joy.

Then the prince came to her, and, taking her hand in his, said, "Dear Princess, how can I leave you!"

And he bent his knee before her and kissed her hand in homage. He opened a little casket, took from it a golden girdle, and hung it about the princess's waist.

"Grow wise, little Princess, and good-by," he said.

He kissed her hand again. They stood for a moment gazing down from the balcony. And below, on another balcony, they saw the Princess Peas-blossom and the Princess Clover looking up at them.

"Good-by," said the prince, and yet again, "good-by."

The Princess Alone watched him depart, not knowing whether she was most sad or most happy.



BEFORE the dawn of the next morning the Princess Alone was awakened by a rough voice near her bed. She had scarce time to grasp the golden girdle from under her pillow and hide it, before she was seized by

strong hands, dressed in a coarse dress and heavy shoes, and led forth from the castle. In the gray dawn she was hurried far away on the broad road that led out of the kingdom that should have been hers, and was told never to come back.

Thus began for the Princess Alone a long year of wandering, full of many strange adventures. Once she fell in with some charcoal-burners in a great forest, and lived with them many days. They were rough, but they were kind to her, and she learned their ways.

One day when they had all gone to a far city to sell their wares, and while she was sitting by her heap of charcoal in the market-place, she heard the sound of a bugle. All the people stopped their buying and selling and turned to watch. Then there came into the square a company of soldiers with bright helmets and polished shields. In their midst walked a prince—and it was her prince—with a beautiful princess by his side. They went about from stall to stall. But the beautiful princess would not speak to the people to whom the prince spoke.

By and by they came to her own stall, and the heart of the Princess Alone beat loud. And grief filled her heart, for she saw that the prince did not know her. A tear ran down her cheek, and left a fair white line where it washed away the dust of the charcoal.

Now there stood next to the prince a soldier, his polished shield resting on the ground. The Princess Alone looked into the shield and saw her own reflection. And she was so ragged and so black with dust that she did not know herself. She saw then why the prince did not know her, and her heart was comforted.

She knelt before the prince, and he said to the beautiful princess beside him:

"Do you not see, Princess, that the child has a fair skin beneath the black dust? Poor little thing!"

But the beautiful princess held her head still higher and turned away.

The prince, however, did not turn away. He took the Princess Alone by the hand and, slipping a ring from his own finger, put it upon hers. "Poor child," he said, "I will buy your heap of coals. The princess does not understand."

A soldier took her heap of coals and paid her. Then the prince and the beautiful princess passed out of the market-place.

## IV



## THE · BUCKLE ·

ONCE, in still another kingdom, when she had stopped at an ill-kept, deserted inn near the public square, the innkeeper told her that he was going on a long journey, and asked her to stay and keep the inn and care for his wife, who was lying sick in an upper room.

So the Princess Alone stayed and kept the inn and cared for the sick woman. She kept the inn so well that the people of the city began to come to it again.

But the poor woman grew worse and worse, and one day, when the Princess Alone stood by her bed, she seized the small hand that smoothed her pillow.

"My little nurse," she said, "beware of that man, my husband. When I am gone you must flee from this house. He is very cruel. Now kiss me and go about your work."

The Princess Alone would have fled at once, but the poor woman needed her, and she stayed.

All sorts and conditions of men now crowded the inn—peasants and merchants, lords and servants, men and women, bad and good, rich and poor, high and low. For many months she lived thus among them, and came to understand many things.

One day a messenger came from the king's palace telling her to prepare a great feast at the inn, for such was the whim of a stranger prince who was passing through. When the feast was ready she sent back the messenger and waited for the guests. Her heart beat fast, for she dreamed that the stranger prince might be *her* prince. And if it *was* her prince, she knew why it was his wish to have the feast in a public place. Yet she was sad, for she was grown wise with her knowledge of men and of the world, and she knew that the prince would not know her now in her cap and apron and coarse dress. And if he ever thought of her, he would think she was still a lonely princess in a high tower, shut away from all the world.

Soon there came the king and queen in their golden coach, and behind them came their daughter, laughing on the prince's arm,—her prince indeed!—and behind them many lords and ladies.

All through the feast the laughing princess talked to the prince. The little innkeeper thought that she was very good-natured. But once, when a maid brought her a steaming dish, the princess touched it and spilled a drop of food on the white cloth, and was very angry with the maid. "Stupid thing!" she cried.

But the prince saw that it was her own fault, and he frowned.

In the midst of the feast a cry was heard in the upper part of the house. For a moment all was quiet. Then a servant came down the stairs and whispered in the little innkeeper's ear, "Our mistress is dead."

The heart of the little princess beat with fear, for she remembered what her mistress had told her. But she could not flee till the feast was done.

Just as she was bringing in the last dish she looked up and saw on the stairs the man she feared. She looked into his face; and now, in her wisdom, she could see that he was cruel. She turned back toward the kitchen, but he came after her and seized her hand and would not let her go. She cried out and tried to break away from him, but he held her fast.

Then she saw the prince himself spring from his chair, and she saw the princess try to hold him back. But the prince drew away from her and sprang after the man and threw him to the floor. Then soldiers rushed in and hurried the man away.

The Princess Alone knelt, trembling, before the prince and kissed his hand. And the prince took a golden buckle from his shoe and gave it to her saying, "Poor little child!"

She looked up into his face and saw that it was very sad. Then the Princess Alone fled from the inn.

## V



## THE · NECKLACE · OF · PEARLS ·

AT last almost a year had gone by, and the Princess Alone had wandered far and had come to know many countries, and men and women of many kinds. But her heart was sad, for she had no home and no one to love her, save only the prince, perhaps. And whether even he loved her still, she could not know.



One day, as she wandered along the broad highway of a strange kingdom, a wagoner met her and asked her who she was. When he found that she was a stranger and homeless he took her to his mother's house. The house was hard by the castle wall, and his mother was keeper of the king's geese. But now she was very old, and she wanted some one to care for her and for her flock. And so the Princess Alone became goose-girl to a strange king in a far country.

Day after day she sat on the hillside and tended the geese. She was lonely, and yet she had nowhere else to go. Sometimes, as she sat there, she would make up songs and sing them. And at such times the geese would gather around her and quack softly.

One day, when the sun shone warm and the breeze blew cool and the meadow was fresh and green and the pond was bluer than the sky, her heart was so sorrowful that the song she made was sad:

"Oh, I have wandered long," she said,  
 "And I have toiled, and prayed, and wept;  
 My early hopes were strong," she said,  
 "And all my faith and vows I've kept.

"My prince has come to me," she said,  
 "And though he saw, he knew me not.  
 Oh, that my love should flee," she said,  
 "And all my longings be forgot!

"And yet I hold them fast," she said,  
 "For they are dearer now than then;  
 Though all my hopes are past," she said,  
 "And can I never love again!"

When she had ended her song the geese quacked softly; and looking up, she saw a tall shadow in front of her. She turned, and there, standing near her, was the prince—her prince! She uttered a little cry and sank back on the grass. And she knew now for the first time that she was in her prince's country, and goose-girl at her prince's castle.

The prince looked long at her, and then he said: "Little goose-girl, I have heard your song and my heart is sad with it. I too have a great sorrow. I love a little princess dearly, but I may not make her my queen. For I must wed a princess who is both kind and wise. And though my little princess is very kind, yet she lives alone in the top of a high tower, and I fear that she can never learn to be wise. As I stood here but now, I thought it was not you who sang, but my little Princess Alone. And your song touched my heart."

"Alas, sire," said the Princess Alone,

"it is indeed sad! I too love one whom I may never wed. But I am happier than you, for I know that my prince is near me. And I need never wed another."

"And do you love a prince?" he asked.  
 "He is my prince!" sighed the little goose-girl.

"High or low, it matters little," the prince said kindly. "And now there will come to the castle many princesses whom I have seen on my journey. Mayhap the Princess Alone will come. But alas! I have seen many princesses who are wiser than she, but none sweeter or so dear."

Then the prince stooped down and put a necklace of pearls about the neck of the little goose-girl.

"Poor child!" he said. "Your heart is kind and your words are wise. Would that my Princess Alone were as wise as you!"

Then he bade her good-by and went away.

## VI



## THE TRIAL

DAY after day, now, she saw the long cavalcades of the many princesses come winding over the highway and climbing the hill to the prince's castle. And one day she saw the cavalcade from her own kingdom, for she knew the banners that streamed from their spears. When they drew near she could see the poor old king—and the unkind queen—and the Princess Peas-blossom and the Princess Clover.

At a distance behind them limped an old, old woman leaning on a staff. When she came to where the goose-girl stood she stopped for a moment, and then came and sat down by her to rest her weary limbs. She said not a word, but suddenly the Princess Alone cried out and stooped over her and kissed her. For she saw it was Wanda, her old servant, who had cared for her when she had lived in the high tower. Then Wanda saw that it was indeed the Princess Alone, whom she had loved, and had long mourned for lost.

Now Wanda was filled with joy. For she had come without hope of seeing her lost mistress at the great trial. Yet she had come, for she had a token upon her that the princess's father had given her for the

Princess Alone to keep after he was dead. By this token, if anything should befall her, she would still be known as a king's daughter. But the Princess Alone had been stolen away without the token. And Wanda had mourned for her with a broken heart.

Wanda rose to her feet. And now she stood straight, with new hope in her old face.

"My little princess," she said, "the great trial will come to-morrow, and you will go to the castle and take part in it. I long to hear the tale of your wanderings and learn how you came to be here, keeping the prince's geese. But till the trial is over we shall have no time."

"Alas, I can not!" said the princess. "All the keepers know that I am but the ragged goose-girl, and they would turn me away from the castle gate. Besides, I have no gown that a princess should wear, and nothing to show that I am a princess. And alas! I have no wisdom to become the prince's wife. I have heard him say, with his own lips, that the Princess Alone is not wise."

Wanda waited in silence, and when the maiden was done she said: "Listen to me. I have a token that will let you in at the castle gate and show that you are a princess. And in my bundle I have the gown that was all that was left me of my Princess Alone."

"But," the princess answered, "if I should fail—would not that be harder for the prince to bear?"

Wanda stood for a moment in thought. "Listen," she said at last. "You shall go to the trial dressed as a strange princess from a far country whom the prince has never seen. Then, if you should not win, the prince need never know. But if you do win, then you can go to the prince in your own dress, and he will know you are the Princess Alone."

The heart of the princess misgave her, but she promised to be brave and do as Wanda bade her. Then Wanda went into the city and brought back a strange, sad-colored dress, and clothed her in it so that no one who had ever known her before would have known her now. The princess made a bundle and in it put the fair white gown of silk and the golden girdle and the ring from the prince's finger and the buckle from his shoe and the necklace of pearls.

Next morning, when the sun was high, Wanda took the bundle with her and drove

the geese to the meadow. And the Princess Alone went to the castle gate. When the keeper saw her token, he stared at her hard, but he let her in.

Straight she went to the great court-room. Already it was crowded. The princesses were seated in a row, all in their costly robes; and on the seat of judgment was the old king, the prince's father. For he was to sit in judgment over the princesses.

When the strange princess appeared before the other princesses they all laughed, for she was dressed in her sad-colored dress. But when she showed her token to the king he bade her take her place among the others. At that, all the princesses drew closer together, so that they might not be seated near her in her plain dress. And she had to go to the last seat of all.

As she passed slowly before them she saw her cousin Peas-blossom, and her cousin Clover, and the haughty princess of the market-place, and the laughing princess of the inn. And on the other side of the hall she saw her old uncle the king and her unkind aunt the queen.

Then the trial began, and it was held in this wise: this was the day in that kingdom when the king sat in judgment over all the men and women who were accused of doing wrong; but to-day, instead of the king, it was the princesses who were to sit in judgment. The king would then say whose judgment was the wisest of them all. And that princess was to be the wife of the prince.

Now the first person to be brought before them for doing wrong was a poor man dressed in rags. When he had told his tale and the accuser had told *his* tale, the first princess, who was the princess of the market-place, said, "Put him in prison."

The Princess Clover, who was next, said, "Cut off his hand."

The Princess Peas-blossom said, "Have him whipped."

And the laughing princess said, "Send him into a far country."

Thus, one by one, each princess passed a different judgment, so that the princess who sat next the Princess Alone could scarce think what to say.

But the Princess Alone had once been ragged and black and poor, and more than once, in her long year of wandering, had she been accused of wrongs she had not done. So she said to the man, "Come here and let me talk to you."

The poor man came before her.



"Tell me again why they have brought you here," she said.

"Oh, Princess," answered the man, "I am a poor wood-chopper, and my accuser says that I have gone beyond my part of the forest. But I did not, and that I am sure of."

"Who is your accuser?" asked the princess.

The accuser was brought forward. The princess asked him to show that what he had said was true. But he could not show that it was true.

And she said, "If the accuser can not show that what he says is true, then let the wood-chopper go free."

And the king said, "So be it."

Then all the princesses tossed their heads. But they took counsel each within herself, for they saw that they had been wrong and she had been right.

The next prisoner was then brought forward. He was accused of cruelty. And the first princess said: "Come here and let me talk to you. Why have they brought you here?"

"I am accused of cruelty," said the man.

"Who is your accuser?" asked the princess.

The man's wife came forward.

"Can you prove that he was cruel?" asked the princess.

The woman burst into tears and said nothing.

Then the first princess said, "Let him go free." And all the other princesses said to let him go free.

But the Princess Alone said, "Come here and let me look at you."

They brought the man before her and she looked into his face and saw that it was a cruel face.

"Is there no neighbor here," she asked, "who can say whether this man has been cruel?"

Three neighbors came forward and said that the man had been very cruel to his wife. Then the man's wife fell upon her knees before the Princess Alone and cried out, "Don't, don't! He will not be cruel again."

But the princess said, "Let him be scourged. And if he is cruel again, let him be scourged fourfold."

And the king said, "So be it."

Then the other princesses tossed their heads again, and now in anger, for they knew not what to say to the next who should be brought before them.

One after another the accused persons

appeared. But the other princesses had never talked to men and women outside their fathers' castles; and, this being so, they knew not what questions they should ask, and knew not what to make of the answers they got.

But the Princess Alone had talked to all sorts and conditions of men—servants and beggars and butchers and farmers and lords and ladies and shepherds and strollers and tinkers, good and bad, high and low, rich and poor, wise and foolish, and so she had come to have an understanding heart. She knew what questions to ask, and she knew what to make of the answers she got. And so it was that each time, when she had pronounced her judgment, the king said, "So be it."

When at last all the accused persons had been tried, the king stood up before his judgment-seat and said:

"There is a law in this country which says that the prince must marry a princess who is both kind of heart and wise. Sometimes this law is hard for the prince to bear. But now I think that this law has proved a great blessing. For this strange princess is the kindest and the wisest of all the princesses I have ever seen. And she shall be the wife of the prince."

Then he took the Princess Alone by the hand and led her to where the prince was standing.

The prince's face was sad as he knelt before her and kissed her hand. Then he rose and said, "Will you tell me your name, O Princess, and from what country you have come?"

"To-night I will tell you," she replied. "Not till to-night."

Then she turned and fled from the room.

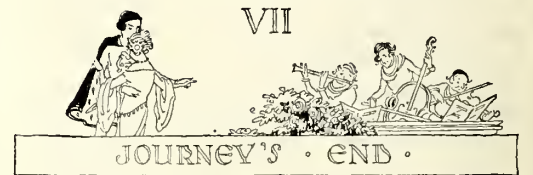

ALL the rest of the day the Princess Alone sat in the meadow and told to Wanda the story of her wanderings. And when she was done, her heart was so full of happiness that she sang a joyous song:

"Cool blows the wind from the hills;

Warm is the sun on the heather;

Gentle the voice of the rills,

And all in my heart is fair weather.



"HE SAW NOT A STRANGER PRINCESS, BUT HIS OWN BELOVED, THE PRINCESS ALONE"



"Hither sweet melodies float  
From the feast in the castle above me;  
The lilies lie fair on the moat;  
Thus may I on his heart, an he love me.

"Liquid the meadow-lark's song;  
Sweet breathes the air on the clover;  
Hurtles the shy deer along,  
As I in my quest—and it 's over."

When night came at last, they drove the geese home. Then Wanda dressed the Princess Alone in the gown of pure white, and put the golden girdle about her waist, the ring upon her finger, the golden buckle on her shoe, and the necklace of pearls about her neck.

When they heard the music from the open windows of the castle the princess climbed the steep hill, passed the keeper at the gate, and went in. When she entered the ball-room she looked quickly about for the prince. He was standing apart with his head bowed. She went to him, and, kneeling, held up the token. And the prince knew that this was the strange princess whom he must marry. He raised her gently to her feet.

The Princess Alone looked up into his face, but the prince's eyes were downcast and sad. Then his downcast eyes caught sight of the golden girdle that he had given to the Princess Alone in the top of the high tower. He uttered a cry, and, looking into her eyes, he saw not a stranger princess, but his own beloved, the Princess Alone. And they fell into each other's arms and wept for joy.

Across the room they heard a little cry, for the queen her aunt and her cousins Peas-blossom and Clover now saw who the strange princess was. And her uncle the king came to her and kissed her.

The prince, who had held her hand in his all this time, now saw on it the ring he had given to the little charcoal-burner in

the market-place of a far city. And he cried: "Oh, my Princess Alone! the ring on your finger I once gave to a poor little girl in the market-place of a far city. By what strange chance has it come to me again?"

"Ah," she said with joy, "truly you gave it in kindness to a poor charcoal-burner whom you saw in a far city. And I was that charcoal-burner."

Tears stood in the prince's eyes, and he fell on his knees humbly, to think of the suffering his princess had been through. Then his eyes fell upon the golden buckle of her slipper, and he cried, "And the buckle on your foot was taken from my own shoe, and given away in another kingdom."

"Ah," she murmured with pride, "truly you gave it in pity to the little innkeeper whom you saved from the hands of a cruel man. And I was that innkeeper."

The prince was lost in wonder and admiration and pity. He embraced her again, and his eyes fell upon the necklace of pearls about her neck. Again he cried, "My own princess! but a little time ago that necklace was given to a servant in my own household, for the sweetness of the song she sang in the meadow."

"And ah," she said, and her eyes were full of love, "truly you gave it to the little goose-girl, in your sympathy. And I was that goose-girl."

Then the amazement and love of the prince knew no bounds. For he knew that never was a man so blessed as he, after long sorrow and trial, and never a man with a bride so beautiful and so kind and with so understanding a heart.

And she came to be known as a great and wise queen. All her people loved her and called her the Princess Helene.

But the prince always called her *his* Princess Alone.

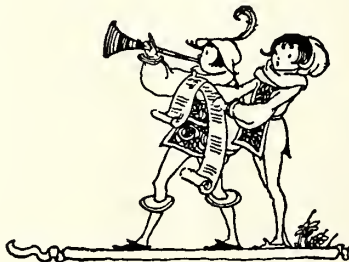

# THE "EAGLE" AND THE "HEN"

By ARTHUR W. PEACH

JUST after the bugle had blown for supper, while the boys were on their way to the big dining-room, two men, carrying leather cases, came hurrying through the tents and toward the cottage. All the boys stopped and looked at them with surprise. Camp Brent, a summer camp for boys, was three miles from the main highway around the lake, and visitors did not usually come on foot or appear to be in such a hurry. It seemed clear that something was in the air.

Ted Dillon happened to be near Mr. Lane, the director of the camp, when the older of the two men spoke:

"Mr. Lane, I am Doctor Field, from the village, and this is Doctor Ferguson, from the city hospital. We were on our way around the lake to Mill Village, where we have been called for an emergency operation in the case of a little girl; but our car broke down, and, as we are miles from another, we are wondering if you can not take us across the lake in your launch? It is more than twenty miles around the Neck, and if we can go right across, we can save time."

Mr. Lane looked sober. "I do wish we could help, but the launch is out of commission. The skipper is working on it now," he pointed down to the shore, where an old man could be seen working over the engine, "and I doubt if he can get it in shape. But something ought to be done. Now, we might put you in a canoe—"

Doctor Ferguson smiled. "Not my two hundred pounds. It would mean too long a trip, and we must get there just as soon as we can."

Ted had been listening anxiously, thinking of his own bright-headed little sister and what it would mean if she were very ill. Suddenly an idea occurred to him.

"Mr. Lane, a war-canoe could do it!" he said quickly.

Mr. Lane stared at him, and then jumped. "That's it, Ted! You have the idea. Doctor, we'll send you in the *Eagle*. I'll make arrangements right off."

Ted felt his heart sink. There were two big war-canoes in the camp, built on the lines of the great war-canoes of Indian days, that would hold eight paddlers on a side. They could be driven through the water

very rapidly, and, by resting different paddlers, a steady rate of speed could be kept up. One of the canoes was called the *Eagle*, a long, finely built canoe that had been bought that year; the other was an old canoe, a bit squat and flat, strong enough, but homely as the day is long. This one was called the *Hen*, and Ted was captain of the crew. Now it looked as if the *Eagle* was to have the chance to be of great service.

The bugle sounded from the tents, giving the call that drew the crew of the *Eagle* together. Ted could see them running to the tent of the captain, Brooks Gardiner. Suddenly, as he stood in thought, another idea came. He started on the run to find Mr. Lane. He found him in the kitchen, giving orders for a lunch to be put up for the crew of the *Eagle*. They would be out all night, and must start without their supper.

"Mr. Lane, why not let me take the *Hen*, too? We can put a doctor in each one. We can get them there faster; and besides, you know there are rocks in the Narrows. May we, please? I want to help."

Mr. Lane thought a moment and said quickly: "That is the best plan, Ted. Get ready."

Ted sprinted to the tents, found Ames, the bugler, and gave him Mr. Lane's order. The bugle shrilled its warning, and Ted's crew came hurrying from the cottage. Quickly he told them what was to be done. They listened eagerly, for they were intensely loyal to their own canoe. They had won positions on the crew the preceding year when the *Hen*, then known as the *Arrow*, had been the only war-canoe in the camp. When the *Eagle* came, they all decided not to give up their first love, and they were still the crew of the old war-canoe.

Ted was getting out his megaphone and sweater when Gardiner, captain of the *Eagle* crew came up. "What's this? You and that old tub going?" he said a bit crossly. "You don't need to. We can take the doctors across."

Ted looked up. "Gard, you're never willing to give another fellow a chance. Now, watch out! we're going across that lake like a hoop around a barrel; and my old tub is going to do her duty to-night.



You and the *Eagle* do the same, and nobody will have any fault to find."

"Oh, you can go, but you won't be needed."

"All the better then."

Ted gave the word, and his crew took their places. He went forward and put his searchlight in position, for he knew it would be dark before they reached the other shore, and he would need the light through the Narrows.

The doctors came down with Mr. Lane, who caught sight of the searchlight and turned to Gardiner. "Brooks, you will need a light—better get it."

Brooks had forgotten, and he scowled a bit as the *Hen's* crew joked him. He was still more disgusted when he saw Ted's smile. He smiled in turn, however, when a moment later the great city surgeon, after looking over the *Hen*, climbed into the *Eagle*.

Amid a chorus of cheers, the war-canoes started on their errand of life or death. The *Eagle* picked up a fast stroke of a racing type. Calmly, Ted gave orders for a slow, swinging stroke that he knew his crew could keep up for hours.

The *Eagle* drew rapidly ahead. Doctor Field turned to Ted. "They will get far ahead of us, lad, at that rate. Can't you speed up?"

"I can, sir, but I think we shall get there as soon as they do. We are using an Indian stroke for long trips; they are using a racing

stroke. I know the way, also," was Ted's quiet answer.

A cool wind, blowing across the miles of the lake, struck them as they turned the point. Far off, the western mountains loomed, majestic, calm, with the sun beginning to sink behind them. There was no



"WHAT 'S THIS? YOU AND THAT OLD TUB GOING?"

Soon the two crews were gathered at the wharf. Ted's crew stood with paddle blades up, waiting for the signal to get into the *Hen*. He had carefully trained his crew to do nothing without signals. Gardiner's crew had not been so well drilled, but they were a strong, husky group.

sound save the soft swish of the paddles as they fell, sank, and swept back in perfect time to Ted's counting voice.

The *Eagle* drew farther and farther ahead. Once Gardiner looked back and grinned; and Ted suddenly realized that Brooks, skilful as he was, beyond a doubt, and clever, had hoped to draw Ted into a sort of race and first weary him and then outdistance him.

"This is a bigger thing than a race to see if we can get there first," Ted said to himself. "It 's really a race against death."

So he did not change the stroke. Brooks looked back again, and Ted smiled to see that he had given the order which changed the racing stroke to a slower one.

Ted and his crew, regarding the old *Hen* as they would an old friend, knowing her ways, kept the long, swinging stroke going, and soon they began to crawl up on the *Eagle*. Brooks looked back with a scowl and tried to quicken his stroke; but his crew had not done the hard practising that Ted's had, and slowly Ted came up. Then he softly gave the word that changed his crew's stroke to a slower one—he would let Brooks lead the way if he wished.

The sun had set behind the mountains, and twilight was coming in its still, mysterious way. The wind rose a little and became a bit cooler. Through the growing dusk, the Point light burned dimly.

Doctor Field turned. "I suppose this lake has seen, in the years of old, many a war-canoe on its way," he said, looking off to the distant mountains.

"I often think so," Ted replied. "We have found arrow-heads, sometimes, in digging around camp."

He changed the stroke again, to rest his crew, but the *Hen* went forward without seeming to lose speed; and her bow crept close to the *Eagle*.

Ted could see that the *Eagle's* crew were growing weary; the sharp stroke they had used in starting had tired them, they had not trained as steadily as had his crew, so they were not in as good condition to stand the long grind.

In silence, save for the sound of the paddles dipping deep at either side and the soft *swi-ss-sh* of the water parting at the prows, both of the great canoes glided forward; and slowly the foot-hills above Mill Village began to loom through the twilight, darker than the rest of the horizon.

Then the stars came, golden bright overhead, and with them the night seemed to grow darker. Two more miles passed, and they drew near the Narrows—a wide gorge which was the quickest approach to Mill Village from the east, but dangerous in places with its hidden ledges.

As the black mouth of the gorge yawned, Ted gave the reverse signal, and the paddles, going deep, stayed the onward sweep of the great canoe. Then he gave the order for the lighting of the searchlight. A hiss, and its broad beam drove back the night with a rush. Gardiner, seeing it, halted his canoe, and soon his light aided in the battle against the darkness.

Once more the sharp signals, and the canoes glided forward. Ted was astonished to see that Gardiner had signaled a faster stroke than seemed necessary, and guessed the reason. The *Eagle* was to have the honor of beaching first at Mill Village.

"It 's a bit dangerous, though," Ted thought to himself, and kept his stroke to a slow, short dip. With his big steering-paddle he kept the *Hen* true. In and out through the gorge they went. The black rocks drove high into the air on each side, then fell away suddenly into little glens.

With a suddenness that startled him, the *Eagle* seemed to slow down, as if brakes had been applied, or some giant hands had reached up from the dark channel and grasped the canoe. A rasping sound came faintly back.

Sharply, he gave the reverse order, and his canoe came to a standstill.

A worried voice came back from the *Eagle*, echoing hollow from the rocky sides of the Narrows:

"We 're on a ledge!"

There was a sound of confused voices, then another shout:

"Water coming in here!"

Ted knew that every fellow in the canoe could swim like an eel, for no boy was allowed by Mr. Lane to go even into a row-boat until he had passed difficult swimming tests. But the doctor and his valuable instruments and the delay—

Clearly, Ted gave the full-speed-ahead signal. The paddles, which had been held upright, went down deep and hard, and the *Hen* seemed to jump from the water. A few strokes, and, at the reverse-signal, the canoe came to a halt.

Gardiner's face was haggard in the glare from Ted's searchlight. "If you 'll take





"IF YOU 'LL TAKE THE DOCTOR INTO YOUR CANOE, TED, WE CAN GET THE "EAGLE" ASHORE ALL RIGHT!"

the doctor into your canoe, Ted, we can get the *Eagle* ashore all right. It's a small leak, but I guess we're done for for the rest of the trip." The searchlight on his canoe had been busy. "There's a good landing-place just across. We've got some emergency stuff, and we'll camp there. I'm mighty sorry; I had the fellows go too fast; and I'd forgotten about this ledge. I should have known better."

Ted ran his canoe to the stern of the *Eagle*, then a little beyond. The sides were locked; and soon Doctor Ferguson was seated in front of Doctor Field. When Doctor Ferguson's weight was removed and two of the boys had stepped carefully out on the ledge, the canoe floated, and Ted saw that the *Eagle* would soon be resting on the rocky shore with its crew safe if not comfortable.

Once more Ted gave the word, and to the farewell call of Gardiner, "Good luck, fellows!" the old *Hen* began the last lap of her journey.

Ted was thankful that he had made so many trips to Mill Village for Mr. Lane. His searchlight, flaming through the dark-

ness, brought into view many familiar landmarks; and watchfully, steadily, Ted heeded their warnings thrust through the night like so many dark, guiding fingers. Evenly, tirelessly, the paddles fell as he counted the stroke. Then, rounding a rocky wall, the Mill Village lights twinkled above the searchlight's beam. A moment later, eight pairs of hands seized the side of the village dock, and the doctors, a little lame and cramped from their unusual journey, climbed carefully out.

Doctor Ferguson turned to them. "Boys, your canoe may be called the *Hen*, but I'll tell you one thing—if she is, she is a great old bird!"

The doctors hurried away into the darkness, and Ted swung the *Hen* around; then they started back to join the stranded crew of the *Eagle*, to help them patch the leak, or, if it could not be done at night, to build a rousing camp-fire and wait for the dawn; and Ted knew, from the tone of Gardiner's last words, that hereafter there was to be peace between the war-canoes and their crews—the *Eagle* and the *Hen* would dwell harmoniously together.

# FELICIA EXPLAINS—FINALLY

By MARGARET TAYLOR MACDONALD

I OUGHT to have guessed it! But even now when I look at Phil I can hardly believe that she 's—but I won't tell you. I'll let you see if you would have guessed it if you had been in my place. At the time, I was tempted to write it for my narrative-writing course, but Phil made me promise not to do it. Anyway, if I had, I should have had to think of a lot of boring things that won't worry me now,—things that Miss Jennings says show technique,—scenes and transitions and settings and atmosphere.

And speaking of atmosphere, my first meeting with Phil was just full of it. The time was our first day at college, and the place, 245 Adams Hall, which later was to become the famous "Emerald Alley." But just then it was a discouraging sight. It reminded me of a subway train, narrow and tunnel-like, with a window at one end where the opening into another subway train would be. It was almost as dark as a subway, too, but not quite dark enough to hide walls of seasick green, nor two yellowish oak bureaus ranged with mathematical precision directly opposite each other, so that one atrocity was reflected in the mirror of the other. Two stark iron cots, covered with stiff white spreads, were the only other ornaments in the room. On one of these cots, I had been hopelessly sitting for half an hour when Phil arrived, towed in by a white-sweatered-and-skirted junior who wore a reception-committee tag.

"This is your room-mate, Felicia Armstrong," announced the junior. "And you are—I don't quite remember your name—oh, yes, of course, Margaret Wyeth! I took you from the treasurer to the warden's office—no! from the warden's to the dean's office—well, from somewhere to somewhere else, did n't I? I guess it won't take you long to get acquainted. Please come and see me sometime. I'm Emily Lawrence, and I live in Dickenson, 427." And she departed, somewhat breathless.

Felicia came a little farther into the room and sat down on the other cot. My spirits had risen as soon as I saw her. I had been so afraid that I'd draw that impossible girl I had met at the station that morning.

There was no doubt about it—Felicia was darling looking. She was slight, with

dark, bobbed hair crinkled up on either side of an oval face. Her eyes were gray-blue and wide, and her nose was adorable. Felicia is the only one who laughs when I call it aristocratic. Her mouth—she was smiling a scared sort of smile at me—was very pretty, and, as I found out later, perfectly capable of a well-developed grin.

"I've just been to see the dean," said Felicia, a little gaspily, "and I was afraid that—I was afraid," she finished helplessly.

"I know," I answered with feeling, remembering the look the dean had given my record-card when she came to my math marks. "Were n't all those waiting lines terrific? I never went through anything so hectic in all my life!"

Felicia agreed. She had already come over to my side of the room and was sitting beside me on the cot. The junior had been right in her guess that we would n't be long in getting acquainted.

"Is n't this room dreadful?" she sighed. But it was a cheerful sort of sigh.

"I don't see how we can fix it up," I said. "There was a note on the door from the girl who lived here last year, and she wants to sell us her curtains. They're old rose, she says—" I looked sharply at Felicia, and wondered if we were going to have the same ideas on the subject of decoration. I was not disappointed in her.

"Oh, don't let 's buy them!" she cried. "Imagine old rose with these Paris-green walls! Let 's get some dark cretonne,—mostly green and a little orange, maybe,—one of those queer things, all birds and cauliflowers."

"And let 's have a window-seat with lots of cushions," I added. "And we can call our room Emerald Alley. That sounds awfully plutocratic, don't you think?"

We had almost finished planning the interior decoration of Emerald Alley when some one knocked.

We looked at each other and both said, "Come in!" at the same time. A tall girl, with wonderful golden hair, walked in. She wore a light summer dress, and had the air of one who "belonged." In other words, she did not look like a freshman.

"Is either of you Felicia Armstrong?" she asked.



"She is," I motioned. Felicia had been staring at the girl as if she had recognized some one.

"I 'm Polly Harrison, your advisor, so-called," said the girl, with a nice friendly smile. "I probably signed myself Mary when I wrote you this summer."

Felicia murmured something about receiving Polly's letter, and introduced me.

"I live right above you on the third floor," Polly told us, "and you must both come up and meet my room-mates. Have I ever met you before, Felicia?" She was looking rather closely at her. "Somehow your face seems familiar—"

Felicia blushed. "Perhaps you are thinking of Doris Armstrong, who graduated last year. We belong to the same family. They say there is a great resemblance."

"Are you Doris Armstrong's cousin?" Polly was plainly surprised. "Why—" and then it was her turn to look embarrassed. "You 're so very—" she stopped to pick her words, "*different* from Doris, somehow. That 's why I was so surprised. But I can see the resemblance, now that you speak of it. I did n't know your cousin. I was in several of her classes, though. She never talked much, but she certainly was clever to get through in three years, with Phi Beta, at that. Guess you won't have much trouble with exams if you 're like her."

Felicia had recovered completely from her embarrassment.

"Oh, but I 'll not be like her in that," she laughed. "You 'll find me dreadfully stupid, and I don't want to make Phi Beta—I want to have a good time. Doris was to go to Europe this year, to do graduate work in some musty old university," she added.

Polly changed the subject rather quickly, it seemed to me, and left us in a few minutes.

"Please come up and see me soon, both of you," she said at the door.

We had one more call, from my advisor, who was little and dark and looked younger even than Felicia. Her name was Millicent Warren, but she confided that ever since her freshman year she had been known as "Rabbit." When she too left she repeated at the door what we were to learn is the polite formula for ending a call upon a freshman: "Please come and see me soon. I live here in Adams, up in the north tower—five hundred and something, my room is."

We somehow or other got through the ordeal of walking down the long aisle of

the dining-room with its tables and tables of upper classmen on either side. "If I have to do this three times a day, I won't be afraid of my own wedding," I heard the girl in front of me say, and I had just the same sort of feeling.

After dinner came an exciting evening of



"HAVE I EVER MET YOU BEFORE, FELICIA?"

meeting people and being serenaded, just as our freshmen "bibles" had told us. By ten o'clock we were both ready for bed.

I had a very queer feeling when we turned out the light and the seasick-green walls faded to grayness.

"Are n't you the least bit homesick, Felicia?" I asked.

"No," Felicia explained gravely. "I have n't any family, you know, and I can't ever remember any. I was brought up by a great-aunt—the same as Doris's. And now there is only Doris. She is n't really much like a family. I—sometimes—I did n't get along very well with her." She laughed a stifled little laugh that seemed pathetic to me.

"Oh, I almost forgot that I have a guardian in China," she added. "But he 's

writing a book about conditions over there and won't be back for five years. I've never even seen him."

I did n't know exactly what to say, for it seemed almost like boasting to tell about a family of mother, father, three brothers, and a sister. But as the days went on and Felicia became Phil, and I, Peg, we both began to find out a lot of things about each other. I was interested in Phil's cousin, and I used to try to make her talk about Doris. Polly Harrison and Rabbit Warren, who had been in some of Doris's classes, also told me some things about her.

Phil told me that she and Doris had been brought up together in a gloomy old house by a gloomy old great-aunt. They spent most of their time studying under private tutors and traveling abroad under the eagle eye of Aunt Cordelia. Doris, Phil said, was very clever. When she was sixteen years old, she entered college because of some queer codicil in her father's will that said she had to. Aunt Cordelia was terribly against it, but at least she was conscientious enough to follow out her nephew's wishes to the letter. She would n't let Doris live in the college dormitories, however, but rented a big estate a mile or so away. Doris went to classes every day in a limousine, chaperoned by Aunt Cordelia's maid. Aunt Cordelia would never allow Doris to become intimate with any of the college girls because of an unfortunate incident—a shocking and disgraceful incident, according to Aunt Cordelia. While driving home with Doris one day, she was annoyed to see her niece had become so informal as to wave at one of the girls, and was horrified when she caught a glimpse of the girl's attire. The girl was bound for the hockey-field, clad in a white middie and bright-red bloomers. Her stockings were rolled beneath the knee and she wore an inadequately short leather coat. She was trying to balance a bicycle, hang on to a hockey-stick, and tie a band around her hair all at the same time. Aunt Cordelia never quite recovered from the shock.

Polly and Rabbit told me once that Doris came to class dressed always in peculiar-looking clothes—the sort of frumpy kind tourists wear. And she always wore a hat and gloves, even in the spring. They told me I must n't tell Phil, for it might hurt her feelings, but they thought her cousin was decidedly queer. "But geniuses always are," said Rabbit, "and Phil's a darling,

anyway, no matter what her cousin is. No one could really actively dislike Doris Armstrong," she added, as if she were afraid that she had prejudiced me. "She just was n't anything—innocuous, no personality, but a grind and a genius."

Rabbit was right about Phil. Her personality was n't a lacking thing as her cousin's had been. The class felt it right away, and Felicia Armstrong was elected vice-president at the first class-meeting.

Phil went out for everything. We tried out for hockey together, and, although she had never had a stick in her hand before, she practised so hard that they finally let her sub for the second team. I happened to make the first team, and I'll never forget the party Phil gave to celebrate the great event. She went out for dramatics, too, and did a lot of hard work on the make-up committee. In fact, her schedule threatened to become composed solely of non-academic activities.

I began to get worried. Phil had had several E's in Latin prose, and her last history-written had been a failure. And exams were coming. I even got up my courage to go to Polly, and asked her to talk to Phil. I thought Phil would take what amounted to a lecture from her better than from me. Polly did her best. Phil said she was awfully sorry and she knew she'd been foolish and she would try to work harder; but had n't Polly liked Romeo's make-up in the senior play?

"Hopeless!" said Polly's eyes to mine as she left us.

"Honestly, Phil," I said, after Polly had gone, "you ought to take what Polly said more seriously. Dickey Moreton was called to the dean's office yesterday and told she'd flunk if she did n't do better work in Latin. Now she has to tutor, and can't go out for anything."

Phil grew serious all of a sudden.

"Poor old Dickey!" she said. "I'll stop in her room and see if I can help any."

That was just like Phil. But how she could do anything where Latin was concerned, I could n't see.

However, every day, the hour before Dickey's tutoring lesson, she and Phil would put up an "engaged" sign, and, ostensibly, do Latin together.

"Phil certainly is a wonder," Dickey told me one day with admiration in her voice. "She makes things twice as clear as the girl who tutors me."



I did n't quite believe her until one day they worked in our room, Dickey's room-mates being engaged in repainting the furniture.

"Go ahead, you can't disturb me," I said—I was busy writing a letter home. But pretty soon I found myself listening to Phil's coaching with astonishment.

"Phil Armstrong," I said, when Dickey had departed to tutor, "if you know as much about Latin as that, how do you happen to get D's and E's all the time?"

Phil blushed. "Don't pitch into me, old dear," she begged. "I know I deserve it; but—well, you see I *can* do Latin prose if I put my mind to it."

Dickey pulled through the exam all right, —thanks to Phil,—and Phil herself got through everything with average marks. She pretended to be jealous of my one A in English. I was proud of it myself—so were my family.

"If I had a family who 'd be as glad as that, I 'd work for an A too—maybe," said Phil, when she saw the present Dad sent me.

I had the same queer selfish feeling I always had when Phil talked about a family. She seemed so absolutely alone—even that cousin of hers never wrote to her. "We agreed not to write," Phil explained to me. "We both hate it, and we really have n't any common interests."

I was determined that Phil should have the chance of seeing one family in action, and took her home with me Christmas and Easter vacations. She made a great hit with every one, and Malcolm fell for her hard—much to my delight.

At the end of our freshman year, Phil and I got jobs as counselors at the same camp and had a peach of a summer. We went back to college for sophomore year, which was nicer than the preceding one.

It was when we were juniors that I found out the thing that I should have guessed.

Phil had made the hockey-team that year, and stood a good chance of being made class president at the next elections. And there was junior prom hovering in the near future.

It was of the prom we were talking as we strolled back, hot and disheveled, from the hockey-game. I had been trying to get two of my brothers to come, but it looked as if only Malcolm could get away.

"If Malcolm can't bring another man along for me," I was telling her, "you 'll have to go with him alone."

"Why, I 'll do nothing of the kind!" said Phil, handing me her hockey-stick and tightening the green band that kept the hair out of her eyes. "That is n't Miss Carroll coming this way, is it?" she asked. The coats we were wearing were not of the length prescribed in the list of regulations "to be worn over bloomers on the campus."

"No, but we 'd better hurry and get inside," I answered. "If you won't go alone with Malcolm, we 'll divide him. You can have him for one half the evening, and I 'll have him for the other." We were entering the front door of Fortmount Hall.

"We-ll," Phil was saying, and suddenly she stopped short and looked straight ahead. Just before the entrance to the reception-room stood a gray-haired old gentleman, in a dark gray suit and gray spats. He was talking rather excitedly to one of the maids. His voice had a carrying quality.

"Miss Armstrong—Miss Doris Armstrong, I said. She 's a graduate student of the college," the old gentleman was saying.

"The only Armstrong in the college," the maid was consulting a small directory, "is Miss Felicia D. Armstrong. I think she 's from near Boston."

"Humph, there must be some mistake in the book," the old gentleman grunted, "there are n't—there can't be—"

Phil and I were standing quite still. She had gone white at the mention of her name.

"Some one looking for Doris," I began.

But Phil did n't answer. Instead, she grabbed tight hold of my hand and walked toward the old gentleman.

"Here 's Miss Armstrong now," said the maid, obviously embarrassed at Phil's attire.

"Are you Mr. Beresford?" asked Phil.

The old gentleman nodded and seemed greatly surprised—either because of our hockey costume or because of Phil's question.

"Won't you come into the parlor and I 'll explain. Please, Peg, I want you too," she added, as I turned away. "Mr. Beresford, my room-mate, Miss Wyeth." She dragged me into the room with her, and he followed. When we were seated, Phil looked straight at Mr. Beresford and began:

"I am Doris Armstrong," she said. She never even glanced at me, but went on hurriedly. "I—I have a good many things to explain, Mr. Beresford, and I 'm afraid you won't understand what I 've done and why I 've done it. I 'm not a graduate student here at all—I 'm a junior. And I 've been masquerading under one of my names,

Felicia, just so I would n't *have* to be a graduate student.

"Oh, it 's so hard to explain!" she gave a gaspy sigh. "I don't know where to start. I was only sixteen when I entered college, and I went through in three years. And when I graduated all I had was a Phi Beta Kappa key—not a single friend nor a single good time to look back on. I never lived

of life Father meant me to have when he left in his will that I must go to college. If you can only see what I mean—Oh, dear! I thought you were in China—" Phil was getting incoherent in her eagerness to explain it all. "If you could only understand—" she stopped suddenly, and looked sharply at Mr. Beresford's face.

"Why, I guess you do," she said slowly.

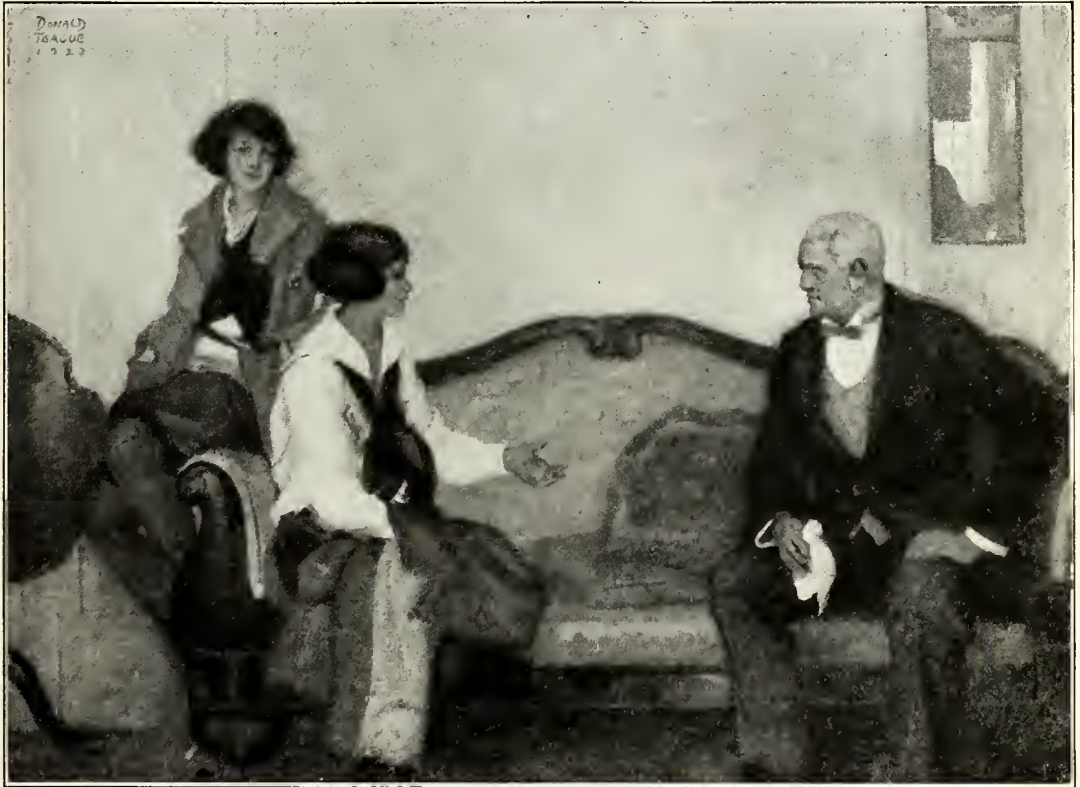

"PHIL WAS GETTING INCOHERENT IN HER EAGERNESS—'IF YOU COULD ONLY UNDERSTAND—'"

at the college—I came to classes in Aunt Cordelia's car, and all I ever saw of college was the inside of a class-room. So when Aunt Cordelia died, and I was left alone, I decided to do just what I wanted to do. I'd go back to college,—the same college,—and get out of it all I'd missed before. It was a risky thing to do, but I did it—and so far I've succeeded in what I set out for. I've had good times—and friends—" Here she flashed a doubtful smile at me. "And, oh, Mr. Beresford, if you only won't spoil it all by telling the faculty! I know it 's wrong and I'm living a lie, though I have managed not actually to tell any." Phil was getting tragic. "But it 's such a glorious life here. I know it 's the kind

I thought Mr. Beresford was going to blow his nose violently, as old gentlemen in stories generally do when they are affected. But he did n't. He just dabbed it gently.

"I'll keep your secret, Felicia," he promised. "It *is* the sort of thing your father wanted you to have—this sort of college life. And it 's all right! You've played a pretty good game too," he chuckled. "I take it that not even your friends know who you are."

He was looking at me, and all of a sudden I realized that I had been sitting with my mouth wide open for the last ten minutes.

"Not even Peg," breathed Phil.

At that minute we were interrupted by a young man who appeared in the doorway.



DONALD  
TRACY  
1921



"ARE YOU EVER GOING TO FORGIVE ME, PEG?" SHE ASKED"

"You missed a corking hockey-game, Dad," he announced. "But I got lost on the way back. Why—" he stopped as he caught sight of Phil and me on the couch, "if there is n't the little one who played left wing!" And he looked at me!

"Felicia, this is my son James. And this is her room-mate, Miss Wyeth. They are dining with us." He looked questioningly at Phil.

"If you 'll give us time to get out of these hockey things," Phil replied. "We ought to apologize for them, but when I saw you in the hall I could n't wait to speak to you."

Somehow or other we got out of the room, I half stumbling over my stick. When we reached our own room, Phil collapsed on the couch.

"Are you ever going to forgive me, Peg?" she asked.

"Forgive you, silly," I said, dropping down beside her. "Why Phil, I think it was the splendidest thing ever any one could do!"

"I 've almost told you a million times," said Phil. "But I was afraid you 'd think I was crazy. I knew you 'd never tell any one; it was just that—well, I don't know. I 'd almost begun to think Doris was another person. But if you really don't care—? Oh! it 's all turned out too wonderfully to be true."

Comprehension of a good many things was dawning in my mind, and while Phil was admonishing me to hurry and get dressed, I began to review things slowly.

"And that 's why you did poor work in Latin, and yet were able to put Dickey through her exam," I said, beginning to unlace my sneakers; "and that 's why you avoided all the members of the Greek and Latin departments like the plague." "Doris majored in Latin and Greek; did you ever hear of anything so deadly?" I quoted.

"Thank goodness, the professor I had for two years straight was away on leave of absence my freshman year!" broke in Phil. "And that 's why I bobbed my hair and bought the best-looking clothes I could find and entered myself as Felicia Armstrong at the college." Phil giggled rapturously. "You don't know how risky it was, though, Peg," she went on, "meeting all the people one had seen before. Why, I sat by Polly Harrison in art for a whole semester! And she, by the way, was the girl who shocked Aunt Cordelia that time."

"That 's why you would n't elect that

snap course in art," I went on; "and that 's why you never had any letters from Doris. But Phil, I don't understand yet how you could be so different from what every one said Doris was. How did you change so quickly?"

"I did n't change, really, Peg," said Phil. "I 've always been this me—the one that you know. Only this me was always being suppressed and being made into a Doris. I used to burst out now and then—but it never did any good. I ran away once,—in Paris,—but after they found me, I never was allowed to be alone a second for months. Aunt Cordelia's Scotch maid hung around like an old dragon. And when I got to college, I was afraid to do anything that Aunt Cordelia forbade for fear she 'd whisk me off to Europe again. Just seeing what I did of college was better than nothing." For a second a wistful little look crept over Phil's face—the kind of look that must have been on Doris's when she was *in* college, but not *of* it. "I 'm not criticizing Aunt Cordelia, really," Phil went on, "for she was trying to make me into a proper, ladylike, Victorian person, and she had a hard job. But I 'd have missed an awfully good time if she had succeeded, so I 'm not exactly sorry she did n't.

"Peg, I 'm so glad you know about it," she said, dismissing Aunt Cordelia from the conversation; "it 's such a weight off my mind! But we 'll have to be careful not to talk about it. If the faculty find out about it, I 'm lost!"

"Oh, Peg," she ran on, "I feel just as if I had a family now—being taken out to dinner by a real guardian. And Peg, I don't believe we 'll have to divide up a man for prom. I 'll go with Malcolm if you like, and I have a feeling that you 're going with Jimmy Beresford, if you only make proper use of this festive dinner."

I pretended not to pay attention to what she was saying, and began to think of all the times I should have guessed that Phil was Doris. If I could only tell Polly Harrison and Rabbit Warren—but of course I could n't. Phil, knowing my habits, made me promise never to try and publish this story until she was safely graduated—"and married," she added, as an afterthought.

No one ever did find out Phil's secret, and we did n't have to divide a man for prom. And I have Phil's permission to publish this story!



# TRAPPED BY THE RED TERROR

By WALLACE HUTCHINSON

*B-r-r-r! B-r! B-r! B-r-r-r! B-r! B-r!* sang the telephone at the Junction Ranger Station.

Heavy steps shook the rough pine floors. Hoarse voices called out strange orders. The beat of horses' hoofs—the tinkle of a bell—the click of a receiver—then silence.

All night long these discordant sounds had broken my sleep, until my nerves were on edge. Jumping out of bed, I pulled up the shade. The sun was shining blood-red over the tree-tops. A long pack-train, heavily loaded and led by a white bell-mule, was swinging out of the yard. Ghostlike figures hurried hither and thither in the smoky pall that clung to the ground and all but blotted out the near-by mountains.

Dressing hastily, I threw open the door and stepped into the station office. A gaunt figure in forestry-green uniform, with haggard face and bloodshot eyes, was standing in front of a large wall-map of the Clearwater National Forest and methodically sticking red- and black-headed pins into its surface.

"Morning, stranger! How 'd you sleep?"

"Pretty fair, thank you, Ranger Bill! You sure had a busy night! How are the forest fires coming along this morning?"

"Well, they might be better and they might be worse—depending on which way you look at it. There 's been twelve fires reported 'under control' in the last twenty-four hours, and I 'm just putting in these black pins to show which ones are out. Two of them there, over the pins with the little flags on them, were over a thousand acres each and bad fires. Then, too, I 'm glad to say, our pack-trains are all working close to schedule; there 's plenty of men on their way in to help fight fire; lots of grub and tools and bedding waiting for them here; telephone lines in good order, and everybody cheerful."

"Fine! I thought from all the racket—"

"Hold your horses a minute, son! I ain't only told you the bright side yet. Listen to this! The smoke-chasers say the thunder-and-lightning storm yesterday afternoon set more 'n ten new fires up on Moose Mountain and Indian Ridge—a hard country to get into on account of the heavy timber. These red pins I 'm sticking in mark the new fires to which men have already been sent; and if you 'll look close at the map, you 'll see a lot more red-heads where fires are burning, too.

But that 's not the worst of it: the pack-train going to Black Cañon got lost and had to ditch its load, and that 's probably gone up in smoke by now; and one of the men up at the Papoose Mountain fire got brushed by a falling tree, and we had to carry him out on a stretcher last night; the lookouts are yelling their heads off because it 's so smoky they can't see; that red sun this morning means a fine hot day, and if the wind does n't shift and bring rain, there 's going to be something popping this afternoon."

"Had n't you better turn in and get a bit of rest? I don't believe you 've had a good sleep for a week, from the looks of your eyes."

"It 's been longer than that, a heap longer, but I 'm going to stick it out till the fire inspector gets here from the Oxford Station to relieve me. He 's on his way now. I 'm a bit worried, too, about the men that left day before yesterday for the Cache Creek fire. That 's sure a bad country to get trapped in if you don't watch out, specially when the woods are full of smoke and fires are running everywhere. I tell you it puts the fear of God into a man to get in the path of the red terror of the forest. I 've been there, and don't I know!"

"I 'd like to hear that experience you had with the red terror, if you 're not too tired."

"Tired! Not a bit of it, only dead sleepy. I 'll tell it to you; perhaps it will help keep me awake.

"You see, it all happened this way," said Ranger Bill, hesitatingly. "On the twentieth day of August last year,—and I ain't liable to forget that date, ever,—I was at the Bungalow Ranger Station, ten miles from here up on the Clearwater River. Forest fires! Man, the woods were full of them! The whole country seemed to be burning up, and, with the steady spell of hot weather and lack of heavy rains, things were beginning to look mighty serious. As ranger in charge of this district, it was up to me to play boss, and, believe me, with all my experience at this game, I had my job cut out for me! Of course, I did n't do all the supervising—no one man could have handled all those fires alone; but knowing the country and everything, the other fellows kind of looked to me as leader, and I did my best.

"At times, we had between four and five

hundred men on the fire-lines, and ten pack-trains of twenty horses each burning up the trails bringing in tools and supplies to the fire-camps. Perhaps you think it is n't some job to keep an outfit like that working up to scratch. You 've seen what this country is like—rough mountains, virgin stands of big timber with dense underbrush, only trails to travel over, and fifty miles from nowhere. I tell you in those days there were times I never got a full night's rest for more 'n a month. Talk about the strenuous life, we rangers sure have it during the fire season!

"The particular day I 'm speaking of, three mighty bad fires had been reported in this region. These were located something like the bases on a baseball-diamond, with the Bungalow Station as home plate. The Fourth of July Creek fire was on the east, at first base, about five miles from the station; the Elk Mountain fire was holding down third base about the same distance to the west; and to the north some ten miles, the Sunrise Butte fire was raging around the second sack. Past the home plate and pitcher's box, veering off to the northeast midway between first and second, ran the Clearwater River, a right sizable stream. This was the setting for the little game in which yours truly was going to play a leading part before the sun went down—only I did n't know it then.

"The air around the station had been thick with smoke for days, so that we could n't see a thing of the surrounding country. The lookouts were mighty little use in that kind of weather, and no one knew exactly what headway some of the fires were making. We had fire-fighting crews on a good many of them, but there was n't enough men left that day to send to all three of the new fires, so I decided we 'd tackle the Elk Mountain blaze first, seeing the wind was coming from that direction.

"The twentieth had opened bright and clear, so I hustled a crew of men and a pack-train with supplies and bedding off to the Elk Mountain country with orders to establish a camp on the south side. That done, I decided to go on a scouting-trip to see what I could find out about the other two big fires. From previous experience I knew it would probably turn windy that afternoon, and conditions were just right for a bad crown fire. I don't suppose you ever saw a crown fire, running at race-horse speed one hundred to one hundred and fifty feet above the ground through the tops of the big trees and

showering the earth with flaming brands and crashing tree-trunks? It 's a terrifying sight—an inferno that makes your blood run cold and your heart almost stop beating. And dangerous—there 's nothing man or beast fears more in the forest than a crown fire.

"I got away from the Bungalow Station about eleven o'clock that morning, and struck off to the north on an old trail running a mile or more west of the river. My idea was to get up on the east slope of Elk Mountain and see if I could get the lay of the other fires. Speed was the main thing if I hoped to get back that night, so I kept hitting the grit at a lively pace for an hour or more. Suddenly, from an open spot where I had stopped to get my wind, I noticed a big cloud of smoke beginning to roll up, from the Elk Mountain fire, to my left and behind me. I could see that this fire was being driven by the wind down toward the Clearwater River; and if I tried to get back to the station, I 'd be liable to run into it head on. So I decided the best thing to do was to hurry down the trail to an old burn I knew of, before I got cut off from safety by the flames.

"Away I went on the dead run. As I rounded a bend in the trail that gave me a long view down the river, a sight caught my eye that stopped me dead in my tracks. It was a massive cloud of smoke several miles down-stream. After watching it a few seconds I could make out that it was a great fire being driven by a terrible wind or cyclone, and that it was headed directly my way. 'Well,' says I to myself, 'you 're jumping out of the frying-pan into the fire; and, since self-preservation is the first law of nature, I guess you 'd better hit for the river.'

"Down through the timber I went, falling over roots and logs, bumping against trees, tearing my clothes and scratching my face and hands on the underbrush. There was no trail to follow, and the straightest way seemed all too crooked to me. I was n't afraid, exactly, but somehow I did n't quite take to the idea of mixing with a couple of raging forest fires away off there by myself, and it was no time before I was crashing through the devil's-club on the river-bank.

"I don't know just how to describe that river," said Ranger Bill, soberly. "Of course, it was just an ordinary stream, deep in spots and shallow in others, and a hundred feet or more wide, but to me it meant safety first, safety last, and the only possible bridge between me and escape. Come to think of it, I never remember seeing a more beautiful



sight than the Clearwater River on that August day. I laid down and drank my fill, washed my scratched face and hands, and splashed around in it for pure joy. Now, I figured, I had at least a fighting chance with the red terror, but when I looked at the towering forest on either side of the valley, then at that little silver ribbon winding its way out of the mountains, and listened to the sullen roar of the onrushing fires, well—I just naturally got panicky.

"After reasoning with myself a bit I began to get back my nerve, so I set about to look for a safe place to hide out in. At the point where I came onto the Clearwater, there happened to be a sharp bend, above which the river ran through a rocky cañon one hundred or more feet wide, with perpendicular walls ten to fifteen feet high. Along one of these walls I found a large rock projecting from the bank and making a fairly decent shelter. Below the bend the wind was blowing the fire up the river, and above me it was blowing the fire down-river, so I figured that in the shelter of that rock was the best place for me to camp.

"For a little time things did n't look so awful dangerous, so I climbed up on the bank to watch the big fire that was coming up the valley. I've seen a good many fires in my day which most folks would call 'conflagrations,' but this one had them all beat. It must have been driven by a fifty-mile gale that was starting spot-fires a half-mile ahead of the main fire. The closer it came, the wilder it got. I could see great tongues of flame licking the tops of the trees, and the smoke was billowing up like thunder-clouds. By some sudden freak it completely jumped a small basin or flat about a mile wide, between two ridges, and then came roaring on again. The longer I watched that fire, the more uneasy I got, because I knew that when it reached me it would trap me like a man caught in a fiery furnace. But for the life of me, I could n't figure out anything to do but sit tight.

"I tell you, I saw some wonderful sights that day, and one of the most interesting was the wild animals. A couple of chattering squirrels first attracted my attention from the fire, and after them came a regular Barnum and Bailey circus menagerie. There were chipmunks, rabbits, mink, and martin without number. Every now and again I would catch sight of a buck, or a doe and her fawns, leaping over the brush. Coyotes sneaked through the timber close by. A big

grizzly crossed the river just below me, caught my scent, stopped, and then went lumbering off down-stream. Friend and foe traveled together in the big woods that day, with the red terror on the rampage. I would n't have believed it if I had n't seen it with my own eyes. All the animals seemed to be running from the upper fire toward the lower one, and I says to myself, you fellows are crazier than I am. But I found out later that I was mistaken.

"I'd been so fascinated by the down-river fire and the Noah's-ark procession that I clean forgot the blaze that was coming down-stream. All at once, a dense cloud of black smoke and gas settled down over me, filling my lungs and cutting off my breath. I made a dash for the stream and buried my face in the water. The gas wave only lasted a few seconds, but that was plenty long enough for me, as it left me groggy and gasping. I concluded I'd better be getting ready for the next attack, so waded up to my shelter and started building a rock wall, about four feet high, out into the river. I figured on laying in the water beside that wall, in a pinch, and getting a few whiffs of air whenever I had the chance.

"Except for an occasional gas attack, the fire coming down the Clearwater seemed to lose force after it crossed the ridge above me, but the cyclone of flame that was coming up-stream gained in fury. In a few more minutes the whole world seemed on fire. The forest was a seething inferno from ground to tree-top. The sky became dark as a dun-geon, then burst into lurid flame. Trees two to three feet in diameter were torn from the ground and tossed about like matches. At times, waves of fire would strike the river, raising great sheets of water and filling the air with spray. Gas cloud followed gas cloud. The water became warm from the hot boulders and burning logs that rolled into the river. The stream was clogged with burning, sizzling tree-trunks.

"Where was I during all this holocaust? Under water most of the time, beside the stone wall I built out from the big rock. I was scared plumb through and through, and I ain't ashamed to admit it either. Every minute I thought would be my last, with the trees crashing round me, but the big rock warded them all off, though one or two came close enough to splash me good with water. I nearly suffocated from gas and smoke, but I found there was a layer of fresh air just at the surface of the river, and that, together

with a wet coat pulled down over my head and face, brought me through alive. I reckon the worst of the fire did n't last over fifteen or twenty minutes at that particular point, but it seemed 'ages to me. I tell you, a man lives a long time in a few minutes when death 's staring him in the face.

"Along about sunset, after it was all over,

tried to sleep. I guess I must have dozed a bit, but every now and then some big tree, with roots burned off by the fire, would come crashing down and wake me with a start; or else I 'd be fighting all the animals in the woods, single-handed, or some fool dream like that.

"Early next morning I started back, but it was a long hike, over fallen trees and smoldering logs, for a hungry man, and I did n't get to the Bungalow Station until almost noon. I got another surprise there, too. All that was left of the station was the chimney—the fire had swept her clean. The boys had missed me all right, but they figured I was too old at the game to get caught by fire in a country I knew so well. Besides, they were plenty busy getting the horses and supplies to a safe place. Later in the day I came down to this station, had a good feed and rest, and, outside of a pair of badly inflamed eyes and nostrils, came through my big adventure in pretty good shape."

"That sure was a terrible experience! An ordinary man never would have come through alive. What do you suppose became of all the animals that went down the river?" I asked.

"Oh! they were n't as crazy as I thought," said Ranger Bill, with a laugh. "I discovered afterward, from the tracks, that they all got together in that basin the big fire jumped over, and probably came through without a singe. If I 'd have gone down the river like them, I might have escaped the fire too. You see, man, with all his supersense, ain't got half as much brains, sometimes, as the wild animals."



"A BIG GRIZZLY CROSSED THE RIVER JUST BELOW ME"

I crawled out of the water, wrung my clothes as dry as I could get them, and then just sat down and shook and shook. Nerves, I guess it was, and an empty stomach, because I did n't have anything with me to eat. I did n't dare to start for home 'count of the danger from rolling rocks and falling trees, so I went over to what looked like a safe place on the bank, scooped out a bed in the hot ashes, and laid down, clothes and all, and



# THE TURNER TWINS

By RALPH HENRY BARBOUR

*Author of "The Crimson Sweater," "The Mystery of the Sea-Lark," etc.*

## SYNOPSIS OF PREVIOUS INSTALMENTS

THE Turner Twins, Ned and Laurie, are students at Hillman's School, Orstead, New York, as is also Bob Starling, whose father has rented a residence near by. The former owner of the place, a miserly and eccentric man known as Old Coventry, is reputed to have had much money, almost none of which was found when he died, a few years before. Old Coventry's half-sister, the Widow Deane, lives in a little house at the rear of the Coventry lot, and conducts a shop dear to the hearts—and stomachs—of the students. Mrs. Deane and her daughter Polly, aged fifteen, are great friends of the Twins. In the autumn, while digging out the posts of an old arbor in the Coventry garden, preparatory to making a tennis-court there, Bob Starling's crowbar slips from his hands and mysteriously drops out of sight into the ground. Since Ned and Laurie live in California, they spend the Christmas vacation at school, as do several other boys, among them George Watson.

### CHAPTER XXIII THE SECRET PASSAGE

CHRISTMAS day dawned clear and mild, a green Christmas if ever there was one. And yet, in spite of the absence of such traditional accompaniments as snow and ice, the spirit of the season was there in abundance. Ned and Laurie, wakening early to the sound of church-bells, felt Christmas right from the first conscious moment. When they hastened down the hall for their baths, they could hear George and Hal Goring on the floor below uniting in what they fondly believed was song. Later, at breakfast, besides a perfectly wonderful repast in which chicken and little spicy sausages and hot, crisp waffles played leading rôles, the doctor and Miss Tabitha had placed at each plate a Christmas-card tied by a tiny blue ribbon to a diminutive painter's brush! Later on, there was to be a tree in the doctor's living-room. In fact, the tree was already there, and the boys had spent much of the preceding evening trimming it and placing around its base inexpensive gifts of a joking nature for one another and the doctor and Miss Tabitha and the two instructors who were there.

Laurie and Ned had exchanged presents with each other and had received several from home, not the least welcome of which was a check from their father. And they had bought small gifts for George and Bob. Also, though you need n't tell it around school, Laurie had purchased a most odoriferous and ornate bottle of perfume for Polly! So when, shortly after breakfast, Ned suggested that Laurie take Bob's present over to him, Laurie evinced entire willingness to

perform the errand. That he carried not one gift, but two, in his pockets was, however, beyond Ned's knowledge. A cheerful whistling from the back of the house drew Laurie past the front entrance, and he found Bob, attired in any but festal garments, swinging open the bulkhead doors. A pair of old gray trousers and a disreputable brown sweater formed most of his costume. At sight of Laurie he gave a joyful whoop.

"Merry Christmas!" he called. "I was going over to see you in a minute. Thomas is in bed with a cold or something, and I'm furnace-man and general factotum—"

"Factotum, you mean," laughed Laurie.

"All right! As you fellows say, what do I care? I don't own it. Now you're here, you can just give me a hand with this load of junk. Dad says it does n't look shipshape for Christmas." Bob indicated more than a dozen paint-cans, empty, partly empty, or unopened, and a mess of brushes, paddles, and rags that they had set there the evening before. "I suppose a lot of these might as well be thrown away, but we'll dump the whole caboodle down in the cellar for now."

"All right," agreed Laurie, cheerfully. "First, though, here's something that Ned and I thought you might like. It is n't anything much, you know, Bob; just a—a trinket."

"For me?" Bob took the little packet and removed the paper and then the lid, disclosing a pair of silver cuff-links lying in a nest of cotton-wool. As Laurie said, they were n't much, but they were neat, and the jeweler had made a very good job of the three plain block letters, R. D. S., that he had engraved on them. "Gee, they're

corking!" exclaimed Bob, with unmistakable sincerity. "I needed them, too, Nod. I lost one of a pair just the other day, and—" "I know you did. That 's why we got those."

"Well, I 'm awfully much obliged. They 're great. I 've got a couple of little things upstairs for you chaps. They are n't nearly so nice as these, but I 'll get 'em—"

"Wait till we finish this job," said Laurie. "Grab a handful and come on. Is Thomas very sick?"

"I guess not," replied Bob, as he followed the other down the steps. "He ate some breakfast, but Aunt thought he 'd better stay in bed. I had a great time with the furnace this morning. Got up at half-past six and shoveled coal to beat the band!"

"Where do you want these?" asked Laurie.

"Anywhere, I guess. Hold on; let 's dump 'em on the shelves in the closet there. Then they 'll be out of the way. Some day we 'll clean the cans all out, and maybe we 'll get enough to paint that arbor we 're going to build. Here you are."

Bob led the way to a small room built against the rear wall of the big cellar. Designed for a preserve-closet, its shelves had probably long been empty of aught save dust, and the door, wide open, hung from one hinge. It was some six feet broad and perhaps five feet deep, built of matched boards. Before Bob entered the cobwebby doorway with his load of cans, its only contents were an accumulation of empty preserve-jars in a wooden box set on the cement floor beneath a lower shelf at the back. There were eight shelves across the rear wall, divided in the center by a vertical board into two tiers. Bob placed his load on a lower shelf and Laurie put his on the shelf above. As he drew away he noticed that the shelf appeared to have worked out from the boards at the back, and he gave it a blow on the edge with the flat of one hand. It slipped back into place; but, to his surprise, it came forward again an inch or two, and all the other shelves in that tier came with it!

"Hey!" said Laurie, startled.

Bob, at the doorway, turned. "What 's the matter?" he asked.

"Nothing, only—" Laurie took hold of the shelf above the loosened one and pulled. It yielded a little, and so did the other shelves and the rear wall of the cubicle, but it was only a matter of less than an inch. Bob, at his side, looked on interestedly.

"That 's funny," he said. "Push on it."

Laurie pushed, and the tier went back a couple of inches. "Looks as if this side was separate from the rest," said Laurie. "What 's the idea of having it come out like that?"

"Search me!" answered Bob. "Pull it toward you again and let me have a look." A second later he exclaimed: "The whole side is loose, Nod, but it can't come out because the ends of the shelves strike this partition board! Try it again!" Laurie obeyed, moving the tier back and forth three or four times as far as it would go. Bob shook his head in puzzlement, his gaze roving around the dim interior. Then, "Look here," he said. "The shelves on the side are n't on a level with the back ones, Nod."

"What of it?"

"Nothing, maybe; only, if the back swung out, the side shelves would n't stop it! See what I mean?"

"Not exactly. Anyhow, it does n't swing out, so what 's the—"

"Hold on!" Bob sprang forward and seized the edge of a shelf in the right-hand tier close to the partition board, and pulled. It readily yielded an inch, but no more.

"Wait!" Laurie bent and pulled aside the box of jars. "Now!"

Then, as Bob tugged, to their amazement the right-hand tier swung toward them, its lower edge scraping on the cement floor, and the left-hand tier swung with it, the whole back wall of the closet, shelves and all, opening toward them like a pair of double doors!

"Gee!" whispered Laurie. "What do you suppose—"

"Pull them wide open and let 's find out," said Bob, recklessly.

When the two sides were open as far as they would go, there was an aperture between them some three feet wide. Beyond it was darkness; though, as they gazed, the stones of the cellar wall took shape dimly. Then Laurie seized Bob's arm.

"Look!" he whispered excitedly. Behind, where the left-hand tier of shelves had stood, was a blacker patch about three feet high by two feet wide, which, as they stared in fascination, evolved itself into an opening in the wall.

"Know what I think?" asked Bob, in low tones. "I think we 've found the miser's hiding-place, Nod!"

"Honest? Maybe it 's just a—a drain or something. Got a match?"



"There are some over by the furnace. Hold your horses!" Bob hurried out, and was back in a moment, and was standing at the opening between the doors with a lighted match held toward the opening in the wall. As the little light grew they saw that the stones of the wall had been removed from a space a foot above the floor and three feet high and some two feet wide. Around

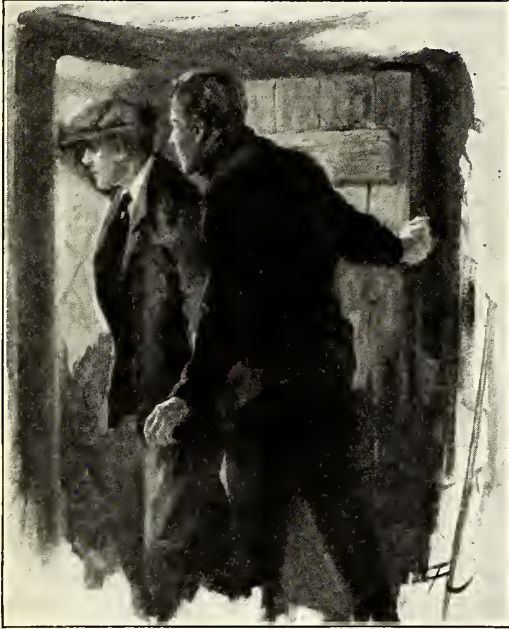

"LAURIE, LEANING PAST THE DOORWAY, RAISED THE LANTERN HIGH"

the opening so made, cement had been applied in the form of a smooth casing. The match flickered and went out, and in the succeeding gloom the two boys stared at each other with wide eyes.

"Would you dare go in there?" asked Laurie.

"Sure! Why not? It can't be anything but a sort of cave under ground. Wait till I get a candle."

"A lantern would be better," suggested Laurie, viewing the hole dubiously.

"That 's so, and there 's one here somewhere. I noticed it the other day." Bob's voice came from the cellar beyond, and Laurie heard him walking around out there. Then, "I 've got it!" Bob called. "There 's oil in it, too! Now we 'll have a look!"

Laurie heard the chimney of the lantern squeak as it was forced up and then drop into place again. Then a wan light came toward the closet, and Bob appeared, tri-

umphant and excited. "Wait till I turn it up a bit. There we are! Come on!"

They passed through between the doors, Bob leading, and stooped before the hole in the wall. Bob held the lantern inside, and Laurie peered over his shoulder. "Gee, it 's high," whispered the latter.

"Yes, and it is n't a cave at all; it 's a tunnel!" said Bob, in awed tones. "What do you say?"

"I 'll go, if you will," replied Laurie, stoutly; and without much enthusiasm, Bob ducked his head and crawled through. Past the two-foot wall was a passage, more than head-high and about a yard in width, stone-walled and arched, that led straight ahead farther than the light of the lantern penetrated. The walls were dry, but the earthen floor was damp to the touch. There was a musty odor, though the air in there seemed fresh.

"Where do you suppose it goes to?" asked Bob, in a hushed voice.

"I can't imagine. But it runs straight back from the cellar, and so it must pass under the garden. Let 's—let 's go on, Bob."

"Sure! Only I thought we were going to find Old Coventry's treasure!"

"How do you know we are n't?" asked Laurie.

"That 's so! Maybe he buried it under the garden."

Their footfalls sounded clearly on the hard-packed earth floor as they went ahead. Suddenly Bob, in the lead, uttered an exclamation, and Laurie jumped a foot and then hurried forward to where the other was standing. Beside him, its point buried in the floor of the tunnel, was the lost crowbar!

"What do you know?" gasped Bob. "We 're under the farther end of the arbor. That bar came through between those stones up here." He touched the crevice in the arched roof with a finger. "See the dirt it brought down with it? Well, that explains that mystery!"

"Yes, but—where does this thing go to, Bob?"

"Let 's find out. It can't go much farther, because the arbor was only about forty feet from the back fence."

But they went that forty feet and perhaps forty more before the wavering light of the lantern showed them a stout wooden door across their path. Formed of two-inch planking and strengthened with three broad cleats, it was hinged to a frame of concrete.

It was n't a big door, but it looked very formidable to the two boys who stood there and viewed it dubiously in the yellow glare of the lantern; for a big square iron lock held it firmly in place.

"Guess we don't go any farther," said Bob, dryly.

"Maybe the key 's here somewhere," Laurie suggested; and, although Bob scoffed at the suggestion, they searched thoroughly, but without success.

"We could bust it," Bob said; "only maybe we have n't any right to."

"I don't see why not, Bob. We discovered it. Let 's!"

"We-ell, but one of us 'll have to go for a hammer or something."

"Sure! I 'll go."

"And leave me here in the dark? I guess not!"

"We 'll both go, then. Hold on! What 's the matter with the crowbar?"

"Of course! I never thought of that! I 'll fetch it!" The light receded down the tunnel until it was small and dim, and Laurie, left alone in front of the mysterious portal, felt none too happy. Of course there was nothing to be afraid of, but he was awfully glad when the light grew nearer again and Bob returned. "You hold this," directed Bob, "and I 'll give it a whack."

Laurie took the lantern, and Bob brought the bar down smartly on the lock. Probably it was old and rusty, for it broke into pieces under the blow, and in another instant they had thrust the heavy bolt back. Then Bob took a long breath and pulled the door toward them. The hinges squeaked loudly, startlingly, in the silence. Before them lay darkness, and Laurie, leaning past the doorway, raised the lantern high.

## CHAPTER XXIV

### A MERRY CHRISTMAS!

"GUESS Laurie got lost," grumbled Ned, kicking one foot against the step and looking across the yard.

George laughed. "Guess you could find him if you went as far as the Widow's, Nid."

"Well, he ought to be back. It 's nearly time for the tree, is n't it?" Characteristically, Ned saved himself the trouble of determining the matter for himself, and it was George who looked at his watch.

"There 's most an hour yet. Let 's go and have a look for him. He and Bob are probably at Polly's."

But they did n't get as far as Polly's just then, for when they reached the corner they descried Laurie tearing along the side yard of the Coventry place. At sight of them he moderated his speed slightly and began to shout, waving both hands in a quite demented manner.

"What 's he saying?" asked George.

"Wants us to hurry," grumbled Ned. "We *are* hurrying, you idiot!" he continued, raising his voice. But he hurried faster, George at his heels, and met Laurie at the front gate.

"What 's your trouble?" he demanded. "House on fire? Bob got the croup? What is it? Can't you talk?"

"Can't tell you," panted Laurie. "You 've got to see—for yourself! Come on!"

He seized Ned by one arm and pulled him away and around the house and down the bulkhead steps, George loping after them. In the cellar stood Bob, disreputable in his old clothes and adorned with dust and cobwebs, a lighted lantern in one hand.

"Has he told you?" he cried, as the others piled down the stairs.

"Told me? He has n't told anything," gasped Ned, shaking himself free at last. "What is it?"

Bob laughed loudly and gleefully. "Then come on!" he shouted. He dashed into the preserve closet, Ned, George, and Laurie at his heels, passed from sight for an instant, and was seen again crawling through a hole in the wall. Ned and George showered questions as they pattered along the tunnel, but all they received in reply was insane laughter and a meaningless, breathless jumble of words. And then they were at the farther portal and Bob led the way through and they followed.

They found themselves in a small, cellar-like compartment scarcely four paces square. It was windowless, although, close to the rafted ceiling in the rear wall, two oblongs of brick set in the stone showed where at some time small windows had been. The floor was paved with flat stones. In one corner, the only objects there, were a small iron chest, its lid swung open and back, and a crowbar. The new-comers stared in amazement, the truth slowly dawning on them. It was Laurie who spoke first.

"Go and look!" he said excitedly.

Ned and George obeyed. Within the chest lay four heavy brownish envelops, fat, bound and tied with pink tape.



"Take one out and open it," said Bob, over Ned's shoulder.

Ned picked up one. Across one end was written in scrawly characters the inscription "Gov't."

"Government," explained Laurie, softly. "It 's full of United States bonds. Nearly a dozen of them. Have a look."

"Geewhillikins!" breathed Ned, in awe, as he drew the folded contents into the light. "Old Coventry's, do you mean?"

"Of course! Whose else? And there are three more lots. We have n't figured them up yet, but there must be fifty thousand dollars' worth!"

"Maybe they're no good," offered George.

"How do you mean, no good?" asked Ned, indignantly. "United States bonds are always good!"

"Well, the others—"

"They're railroad bonds, all of them, three different lots," said Bob. "I guess they're all right, too; don't you, Ned?"

"Right as rain! Why, the old codger—What's that?" he asked suddenly, looking ceilingward.

Laurie laughed. "That's what we wondered," he answered. "We jumped when we heard it first. Don't you know where you are?"

Ned looked around him and shook his head.

"Under the Widow Deane's house!"

"Wha-at! But Polly said there was n't any cellar!"

"She does n't know any better. Look above you. See where the stairway went? The old chap must have torn it away and boarded the hole up; and bricked up the windows, too. It must have cost him a pretty penny to do all this!"

"What—what are you going to do with it?" asked George, pointing to the chest.

"Why, hand it over to the lawyers, wherever they are, I suppose," answered Bob. "But first of all, we're going to take those bonds and dump them into the Widow's lap. I always said I'd hand it all over to her, when I found it. I never thought I would find it, but I have—or Laurie has, because if he had n't noticed that the shelves were loose we never would—"

"Besides," interrupted George, "she comes in for a share of the money. Come on, fellows! Let's do it now! Gee, it will be some Christmas present!"

"Won't it? Let's each one take a package," said Laurie. "We'll leave every-

thing just as it is for the lawyer folks. Come on!"

"Say, fellows, there's an awfully funny smell down here," observed George. "Sort of—sort of sweet, like—like violets or something. Notice it?"

"Yes, I noticed it before I got in here, though," said Ned. "Wonder what it is."

"Oh, places like this get to smelling funny after they've been shut up for a while," said Bob. "And I guess this place has n't been opened for two years, eh?"

"Of course not—not since Old Coventry died. Just the same, it's a mighty funny odor." And George sniffed again perplexedly.

Laurie, who had withdrawn to the door, unconsciously placed a hand in one jacket pocket, where, within a crushed cardboard box, some fragments of glass were all that remained of Polly's present! In prying open the lid of the chest he had brought the end of the crowbar against that pocket, and now the purchase was only a memory, albeit a fragrant one!

Some three minutes later, four flushed-faced and very joyous youths burst into the Widow Deane's shop. To the jangling of the little bell in the back room, Polly appeared, a very pretty, bright-eyed Polly this morning in a new Christmas dress.

"Merry Christmas!" she cried. "Merry Christmas, Nid! Merry Christmas, Bob! Merry Christmas, George! Merry Christmas, Nod!"

Perhaps Laurie should have felt hurt that his own greeting had come last; but he was n't, for a glance went with it that had n't accompanied the others! But although the boys answered the greetings in chorus, it was apparent to Polly that they were there for another purpose than to wish her Merry Christmas.

"Where's your mother?" demanded Bob.

"In there." Polly pointed to the back room, and without ceremony the four filed past and into the little living-room.

Mrs. Deane was seated in a rocker, her spectacles pushed down on her nose, a paper across her knees, and her eyes fixed in smiling inquiry on the doorway.

Bob led the way. On the outspread paper he laid a brown envelop. "Wish you a Merry Christmas, ma'am," he said.

Laurie followed, deposited his envelop beside Bob's, repeated the greeting, and drew aside to make way for Ned and George. The Widow looked inquiringly from the

stout envelops to the boys, smiling tolerantly the while. Boys were always up to pranks, and she liked them, boys and pranks both!

"What are these?" she asked, finally, when the fourth envelop lay in her lap.

Polly, looking over her shoulder, gasped as she read the writing on one of the packets,

"Of course," agreed Bob. "And we could hear you folks up here quite plainly. There goes my last hope of catching a ghost!"

"How many are there to share in the money, Mrs. Deane?" asked George.

"Dear me, I 'm not quite sure." She looked inquiringly over her spectacles at Polly. "Were n't there seven, dear?"



"'NOD! THEY ARE N'T— YOU HAVE N'T—'"

and her eyes, as round as round, looked across at Laurie.

"Nod! They are n't— You have n't—"

"Yes, they are!" cried Laurie. "See for yourself! Open them, Mrs. Deane!"

TEN minutes later, when the first excitement had somewhat subsided, Polly clapped her hands.

"Why," she cried, "now we know what those sounds were used to hear, Mama! They were Uncle Peter down there in the cellar! They were his footsteps! And only a little while ago I thought I heard sounds sort of like them! And that must have been you boys!"

"No, I think there are eight, Mama."

"Well, even then it is n't so bad," said George. "One eighth of sixty-two thousand—"

"Seven thousand seven hundred and fifty," announced Laurie, promptly. "And the bonds may be worth more than we figured, ma'am!"

"Well, I 'm sure," answered Mrs. Deane, "seven thousand dollars is seven times more money than I ever expected to see! I sha'n't know what to do with it." She looked quite alarmed and helpless for a moment, but Polly patted her shoulder reassuringly.

"You must invest it, dearest, and then



you won't have to keep this place any longer, because when I go to work—"

But instead of vanishing, the Widow Deane's alarm increased. "Oh, I could n't give up the store, Polly!" she gasped. "Why—why, what would I do with myself all day?"

"Yes 'm, that 's so!" declared Ned, heartily. "Gee, you could n't do that! Why, we would n't have any place to buy cream-puffs!"

"I guess I would keep on with the store," Mrs. Deane concluded, when the laughter had subsided. "I 'm afraid I 'd never be very happy if I did n't have you boys around. Well, it 's certainly very wonderful, is n't it, Polly?"

"It 's—it 's heavenly!" declared Polly. "This is just the most beautiful Christmas there ever was or ever will be! And I don't see how we can ever thank you all for finding—"

"Gosh!" exclaimed Laurie. "The doctor's

tree, fellows! We 'll have to beat it! We 'll leave the bonds here until to-morrow—eh?"

"But I want to see the tunnel and—and everything!" cried Polly.

"That 's so! We 'll come over after dinner. Come on, fellows! Neddie, come away from those tarts!"

"I was only looking!" sighed Ned.

Mrs. Deane and Polly went with them to the door. Down the street the deep-toned bell in the Congregational church was ringing; and farther away, other bells were joining in a chorus of glad triumph. Mrs. Deane, listening, held a very happy look in her face. On the sidewalk, Ned and Laurie dropped behind their companions, paused, and faced the doorway. There was a quick exchange of glances between them, and then, bowing, Ned began and Laurie finished:

"A Merry Christmas and well-filled bins"  
"Is the hearty wish of the Turner Twins!"

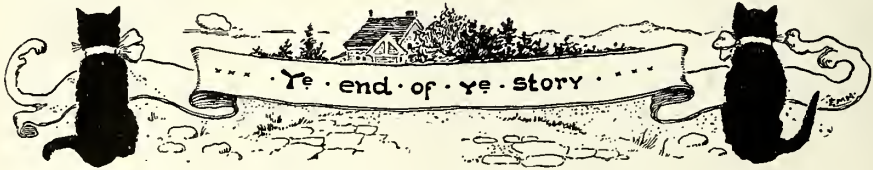

## THE FOREST TROUBADOUR

By HENRY C. PITZ

DOWN in the heart of the greenwood, beside the dim lake-shore,  
Is the trysting-place of the forest folk, and the forest troubadour.  
There, when the blue dusk deepens and the stars wheel on through space,  
The birds and the beasts and the forest folk creep to the trysting-place.

Then the greenwood piper, who comes, when the day is done,  
From the rim of the furthestmost valley, where the sunset gold is spun,  
Plays, as the wood aisles darken, a haunting, witchlike air,  
Till even the hawk is gentled and the gray wolf leaves his lair.

So bird and beast and forest child listen in silent awe,  
Forget their former enmity, forget the jungle law.  
Then fairy bows to goblin and toads creep from the rocks,  
And even the timid forest hares hobnob with the red-tailed fox.

And any venturesome human who finds the trysting-place  
And hears the piper's music is given heart of grace  
To understand the greenwood speech and to follow, unafraid,  
The darkest trail of the forest heart and the wildest woodland glade.





THE GREENWOOD PIPER



# PLANTING YOUR APPLE-SEED

By HILDEGARDE HAWTHORNE

DID you ever hear of Johnny Appleseed? That was n't his real name, but it is the name under which he is known, and under which he went for many years. A strange man, a wanderer, a lover of the open and the wilderness, yet with a vision in him—vision of coming farms and homesteads, of children growing up where the wild creatures ran, of country lanes and orchards, of villages and towns.

In the days when the frontier of our land ran very close to the Atlantic seaboard, Johnny Appleseed lived; and he lived close to that frontier, and beyond it. He tramped on beyond the farthest outposts of the white man's dominions, lived with the Indians, who loved him, and lived alone. He loved the land, he loved America, and he was stirred to do something to prove this love. Lacking money, lacking anything that seemed worth giving, he did what he could.

Wherever he went he planted the seeds of trees, and especially of apple-trees. He walked on toward the west, the unknown, mysterious country that swept away beyond his eyes toward the setting sun; and where he stopped to sleep or to rest, where he saw a likely valley or sheltered hillside, he planted his seeds. And the young trees sprang up after his footsteps; and while he was still planting seeds farther and farther to the west, the trees behind him to the east began to bear. Orchards grew, and the settlers, following Johnny Appleseed in the course of time, found fruit to eat, and saw in the spring the beloved pink and white of apple-bloom that spoke of home to them, so that they built their shacks near the young trees, and blessed old Johnny Appleseed for passing that way.

To-day, American apples feed the world, and are gathered from one ocean to the other. The men who followed Johnny and who have made the American apple so wonderful a fruit, planted in straight rows, and grafted, and sought in all ways to improve and beautify their crop. But they planted for themselves primarily. Johnny planted for America—planted for those who were to come after him, planted fruit he would never see come to its bearing, because he loved the land and it was all he could do for it.

We must all of us, in our life in this world,

plant for ourselves. But how about doing a little planting for America? How about putting in a few apple-seeds just for love of her? There are plenty of seeds that need planting, and that never will be planted unless the planting is done for the love of giving what is good to a land that is beloved.

America is never so much yours as when you do something for her. In giving time, thought, and effort you stimulate your love, and what you love becomes yours in a very special way. When, instead of thinking, "What can America do for me?" you think, "What can I do for America?" you begin to love your country with a real love. And America needs your love tremendously. There are thousands who *take* from America, to one who *gives* to her; if you make up your mind to be one of those who gives, you will be a real patriot, for that is true patriotism, true love of country.

Almost any part of America bears the traces of the despoilers, the destroyers. You can look about you throughout the country and side by side with construction and up-building runs the black witness of a selfishness that takes and takes and never gives.

From Maine to California, you can see, where forests once grew, how these forests have been destroyed. Mighty stumps and moldering trunks still attest to the magnificence of the trees that are gone. Whole tracts of country are barren, where these forests were destroyed and nothing put in their place, so that the rain and the winter frost broke and washed away the very soil, and rocks and desert lie where once splendid trees stood in their noble beauty. If the men who killed them root and branch had had something of Johnny Appleseed in their hearts, they would have used these forests wisely and with love, and to-day trees would stand where trees stood, and the wounded land be whole.

This destroying element in American life has done far more than kill off the great forests. It has poisoned great streams and small brooks, so that all the fish have died out of them, by turning noxious substances into the waters. It has blasted away lovely hills and left the scars behind. It has swept birds and animals out of existence. It has blackened and devastated whole stretches of

beautiful country, taken what it wanted and left desert and ugliness behind.

Much of this destruction is the result of ignorance and carelessness. But we have no right to be ignorant or careless where America is concerned. America is our business, our great, important affair. We need to take the pains to find out what she needs, and what we can do about those needs.

In Sweden, it is one of the customs of young people to plant trees where trees are needed. They will carry pine-cones with them on their tramps and plant them in places where they will grow well and where they will be welcome. Think how much of that we could do during our vacations, if we are city dwellers, or at the best seasons if we live in the country. It is good to know a little about forestry, and if you read a few of the pamphlets issued by the Government at Washington and that may be had for the asking by applying to the Forestry Bureau or the Department of the Interior, you will be greatly interested in the delightful subject. You will get many hints of what you can do and excellent information as to just what America needs in regard to tree culture and planting.

Two boys I know have undertaken to plant fish in the little streams of the country where they live. They can get the young fry free, with instructions as to what is to be done, and they have interested a lot of persons in their work. The streams are being posted, so that fishers will have no excuse if they take fish below the legal size or out of season. Those boys are doing a real service for their country.

In several States you can get trees to plant by applying through the proper channels, and proving that you have the land for the planting. On many a farm or country place, there are hillsides that would welcome young trees, pines or ash or others, as the case may be, and the work of putting them in is a labor of love, if you want to do something you can do, like old Johnny Appleseed so long ago.

One important way in which you can do your bit for America is in being strict with yourself as to keeping the various game laws. Conservation clubs for boys and girls will do a wonderful lot for the country. Such boys and girls grow up with a direct interest in America's wild life and beautiful scenery that will last through their own life, and will help to build up a national sentiment on the subject that is desperately needed. I have been in some of the most marvelously lovely

places in the whole world, here in this great land of ours, and, in these wonder-spots, there will be rubbish and litter and destruction left by tourists who have grown up with no love at all for America, and who therefore do not mind how they desecrate and spoil her beauty. In no other country in the world have I found that sort of thing. This is a state of affairs that you young people can cure, can utterly and absolutely conquer, if you take the thing into your own hands. If you refuse to make a mess of things, if you care enough to preserve and to guard, then America is safe.

Keep your outlook broad. If there is a question that means something vital to the future of America, a question that touches, let us say, Glacier Park in Montana, do not think that because you live in North Carolina or in Maine that it is none of your business. You are, first of all, an American. What touches any part of America touches you. You may never visit any one of the national parks. What of that? They are a glorious part of this America you love, and so they are worth your attention and service. The selfish, destructive element always threatens harm. No constructive work is ever finished. As you grow on toward voting age, as you become one of the managers of this land of ours, you can give some of your time and effort to studying this element of danger, and to learning what is being done to fight against it and what it is possible for you to do.

You see, you have to know. You can't just run blindly out and "do something for America." Even in planting a tree you must know how it is done, and where the tree will be most likely to flourish. Love, to be useful, must be wise.

There are thousands and thousands of you, young, ardent, generous. You are the sons and daughters of America, and she needs all your love and care. Much of your time must be given to solving the problems of your own existence, yet some could be given to solving her problems and to work for her. Even a little, from each of you, would mean a tremendous total.

Carry with you as you go on through life a pocketful of apple-seeds, or their equivalent. Perhaps you will not see the fruit of the trees you planted, but fruit there will be. What you do for America will be done for her, not for yourselves. Yet the doing will wonderfully enrich your own lives, for such is the law.



# SIR CYRIL'S WINNING SHOT

*A Ballad of  
Basketball*

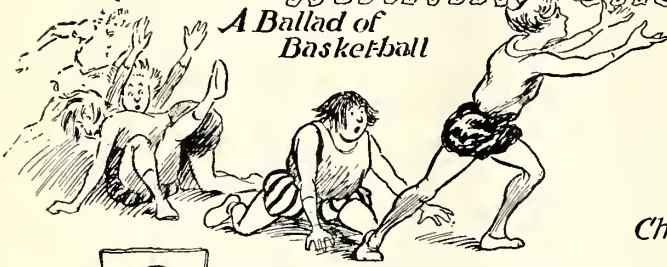

By  
*Charles F. Lester*

**O**

IN an early eve in autumn and a rather rutty road,  
Sir Cyril and his sire, the stout Sir Stephen, swiftly strode.  
"Make haste!" the youth exclaimed. Just then he tripped, I grieve  
to tell,  
And so (how apt!) the son went down just as the evening fell.

Now while Sir Cyril's getting up, perhaps I'd best get down  
To business and explain our hero's haste to reach the town.  
He was playing forward in the royal match at basket-ball,  
And a forward who is backward is, of course, no use at all!



Sir Cyril's team, the Bears, were playing off the final tie  
With the five of bold Sir Thingumbob (the Tigers, by the by),  
So at the Hall the seats were all quite crowded, I may state  
(Especially Lord Portleigh's—he weighed two-eighty-eight!).

The ladies all looked fine, of course (don't ask me what they wore!),  
And guesses at the score were made by maidens by the score.  
Some picked the Bears to win, because their costumes were so swell,  
While others chose the Tigers—they had *such* a stunning yell!

*Lord  
Portleigh*

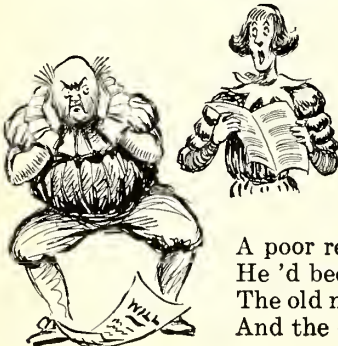

A poor relation, Count de Nix, was sitting with the king.  
He'd been his wealthy uncle's heir—until he learned to sing.  
The old man heard one song, then cut him off without a penny,  
And the outcome was, his income was quite limited—if any!

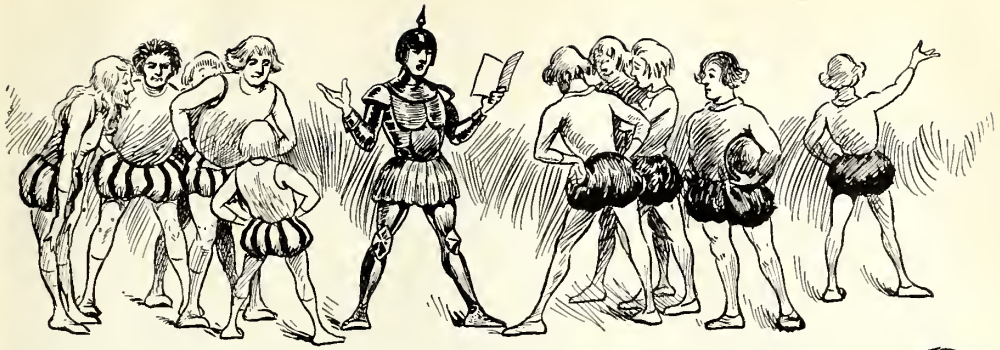

But come—the match! Don't think I'm making light of it (although 'T is sometimes done). The teams were there; the king was waiting;  
so

Sir Dink, the umpire, dressed in mail (he was a prudent man),  
Read the rules and blew his whistle—and the royal match began.

Lord Puffe, the Tigers' forward, was a whirlwind at the start,  
But could n't keep it up (he was too fond of apple-tart).  
His onset at the outset was an asset, I'll agree,  
But was offset by the upset when his wind got short, you see.



Lady Madelaine

Lord Ping, the captain of the Bears, was clever, but quite vain,  
And also most devoted to the Lady Madelaine;  
So, glancing up to win a smile (a foolish thing to try!),  
With his eye not on the ball, he got the ball upon his eye.

The match was hot! With shot on shot the play grew fast and rough.  
The ball is loose!—A desperate dash—Sir Cyril and Lord Puffe!  
Three seconds left—the score a tie!—Those tarts!—Alack-a-day!  
Our hero nips the ball and shoots!—The Bears have won the fray!



Whew! That last verse was strenuous! I feel exhausted, quite,  
So (hoping you are not the same) I think I'll say, "Good-night."  
But let me just suggest this bit of counsel ere we part—  
If you would win at basket-ball—beware of apple-tart!

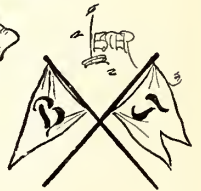



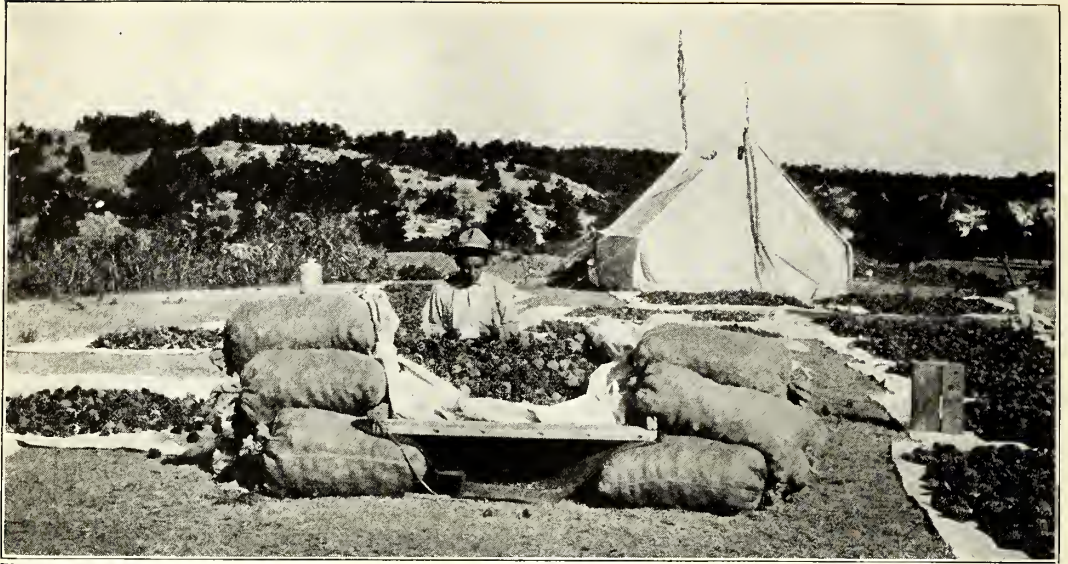

Photograph by courtesy of U. S. Forest Service

SORTING THE CONES WHICH HAVE FULLY OPENED FROM THOSE WHICH REQUIRE DRYING

## THE CONE GATHERERS

By ETHEL CLAIRE BRILL

DID you ever hear of harvesting pine-cones? "Of course," you answer, "squirrels always harvest cones." Many a time you have seen a squirrel run out to the end of a pine or spruce branch, nip off cones, drop them to the ground, and carry them away to his winter storehouse. But it was not squirrels I meant when I asked that question. Men harvest cones every autumn in the national and state forest reserves. They gather them for the same reason that the farmer gathers his seed-corn or seed-wheat.

The idea of raising forest trees from the seed, and taking care of the seedlings, to make new forests, seems extraordinary to you perhaps. But think of the thousands of things wood is used for, from boxes to houses, from matches to telegraph-poles. It is even ground into paper-pulp. Is it any wonder our native forests are being cut off so rapidly? And standing trees are even more important than felled ones. If the woods on the hills where streams have their head-waters are cut or burned off, the streams will descend in destructive floods in the spring and dry up in summer, when the moisture is most needed. A country that is bereft of its trees suffers from drought and is more subject to destroying winds and storms. The fertility of the

soil is injured and the beauty of the landscape spoiled. Yet we can not cease felling trees, for we must have wood for many purposes.

No trees are more important than the evergreens, the cone-bearers with narrow needle-like leaves—pines, spruces, firs, hemlocks. They grow in many kinds of soil and climate, from low land to the highest timberline in the mountains, from Maine to Florida, from Massachusetts to California, from Washington to Arizona. Their wood is used for a great variety of purposes, and the evergreen forests are disappearing rapidly.

Throughout this country there are millions of acres unsuitable for farming. There are rough mountain-sides that can not be plowed, sandy stretches and cut-over and burned-over land that can not be made to grow any useful crop but trees. The forest reserves, set aside by the Government of the United States and of the individual States, embrace not only fine forests, but also thousands of acres of desolate and unproductive land. Some of this land is true desert, but much of it will grow trees if given a fair chance. Cut-over land, where conditions are favorable, and some burned-over land, will sometimes seed and grow up

to good timber without help from man. But many tracts have been so thoroughly swept by fire or ruined by careless logging or sheep-grazing that they will not reforest naturally for many years, if ever. They must be seeded artificially or set out to young trees raised in a nursery. Moreover, there are, in natural forests, spots called "blanks" where, for various reasons, trees do not start, and thin places that can be greatly improved by seeding or planting.

The seeds of cone-bearing trees are not enclosed in a pod, hard nut, or fleshy fruit, like those of broad-leaved trees, but are borne on the surface of scales attached to a central axis and arranged spirally to form the cone. There are usually two seeds to a scale, placed in shallow depressions at the base of the inner side. In the green cones the overlapping scales are closed tightly, and often covered with sticky resin, to protect the immature seeds. After the seeds have matured, the scales pull apart and discharge them. There are some exceptions to this rule, for many of the ripe cones of the northern jack-pine cling unopened to the trees for several years, while those of the western lodge-pole pine, or "fire-pine," often remain closed until a fire sweeps the forest, and, by its intense heat, opens the

airplanes fly farther than three or four hundred feet, though occasionally one may be carried a quarter of a mile. The vitality of the tiny seed is fleeting, and unless it falls in exactly the right place, with all conditions favorable, its life is soon over. Even



Photograph by courtesy of U. S. Forest Service

CARRYING OUT PINE SEED FOR BROADCASTING

if a seed germinates, the tender little seedling is only too likely to be choked by other more swiftly growing plants, wither from too much sun and heat, or die from lack of enough sunlight.

The spruces and firs ripen their cones in one year, but pine seeds are not ready until the second autumn, and it is only at intervals of from three to five years that white and Norway pine bear good crops. Indeed, all the conifers are very irregular in their seed production. A good crop for any variety is called by foresters a "seed year," while the years when the cones are few, scattering, and poorly filled are known as "off years."

One of the tasks of the forester is to estimate the cone crop and discover whether it is of good quality. This must be done before harvest-time. Foresters and rangers go through the woods, noting whether the cones are large and healthy, and estimating the amount of white or Norway, yellow, sugar, or lodge-pole pine, white or red or Engelmann spruce, or whatever varieties the forest contains. By cutting into a few cones, the estimator can discover how well filled they are, and whether the little seeds are plump and healthy. He knows from past experience how many bushels of cones an acre of good-sized, mature trees will average in a good year, and the amount of seed to be obtained from each bushel. So he can calculate the number of pounds of

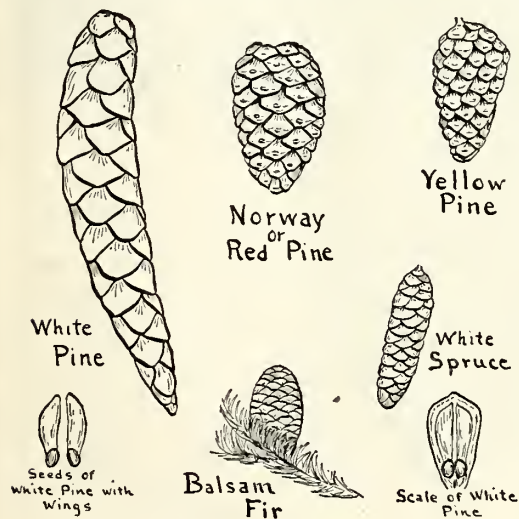

THE PINE-CONE FAMILY

cones and seeds the soil, at the same time that it destroys the trees.

Most conifer seeds are very small and light, and have attached to them thin, membranous wings, for these seeds are intended to be sown by the winds. Few of the little



seed to be gathered from the forest he is examining. After the investigations have been reported, the Forest Service decides in what forests the harvest of each kind of seed is to be carried on that year, concentrating the work in those spots where the greatest amount of good seed can be obtained at the least expense. For example, it was known, months ahead, that 1921 was to be a good year for Norway-pine seed in Minnesota, and, as Norway pine is a very important tree, which seeds less abundantly than other

issued by the forest supervisors, and, during the early part of September, the Indians begin their work. Strange harvesters, are they not, these dark-skinned, keen-eyed men, who travel with swift, noiseless, slouching gait over the forest-trails, undismayed by bad weather, rough ground, or heavy packs? And a strange harvest they are gathering—plump green and brown cones sticky with resin, the long, shapely white-pine cones, the shorter, stouter, thick-scaled ones of the Norway pine, the smaller,



Photograph by courtesy of U. S. Forest Service

RANGERS SCREENING CONES BEFORE SPREADING ON SHEETS FOR DRYING

pinus, plans were made to collect all the cones possible.

Most of the cone-gathering is done in September, but, for some kinds, the harvest may extend into October or even November. It is not always possible to tell from the outside of a cone whether the seeds are ripe. Cones that have begun to turn brown may have immature seeds, while inside those that are still green and resinous the seeds may be quite ripe. From time to time sample cones are gathered, the scales cut off with a sharp knife, and the seeds examined. As long as they are soft and milky they are unripe.

The forest rangers are busy men at all seasons, so, for the seed harvest, extra men must be hired. Indians make good harvest-hands. In the Minnesota forests, for instance, most of the gathering is done by Ojibwa Indians. The call for harvesters is

neatly shaped spruce cones, even the curved, irregular fruit of the jack-pine, all pungent with the evergreen odor.

There are three ways of collecting. The cones can be stripped from felled trees, picked from standing ones, or gathered from the ground and from squirrel hoards. Where logging is going on, the cones can be taken from the fallen trees, but it would scarcely pay to cut down a tree for its seeds. Curved knives, fastened to poles, are sometimes used to cut off the cones from the lower branches of standing trees, or the harvester may climb up and pick them off by hand or with short-handled knives.

Most of the cones collected from the ground are those cut off by squirrels, as those that fall of themselves before the scales open have been injured by insects or in some other way and do not bear good seed. The Indian gatherers of Norway-pine seed in

the Minnesota forests get most of their harvest from squirrel hoards. The red squirrel is a hard-working collector, busily biting off cones and storing them away as long as the supply lasts. He is a wise judge of cones, too,

ever, little, if any, injury is done the industrious little creatures. If a squirrel gathered only as much as he would need for winter, he might starve if his storehouse was robbed. But in a good seed year the little miser lays

up many times what he needs for food, and he does not put all his wealth in one place. He has many caches, sometimes in widely separated places. Even Indian cone-gatherers are not likely to find all his hoards. Moreover, the labors of his men enemies last only a few days or weeks. After the harvesters are through, there is still time for the busy squirrel to lay aside a good store for winter, and there remain on the trees plenty of cones not

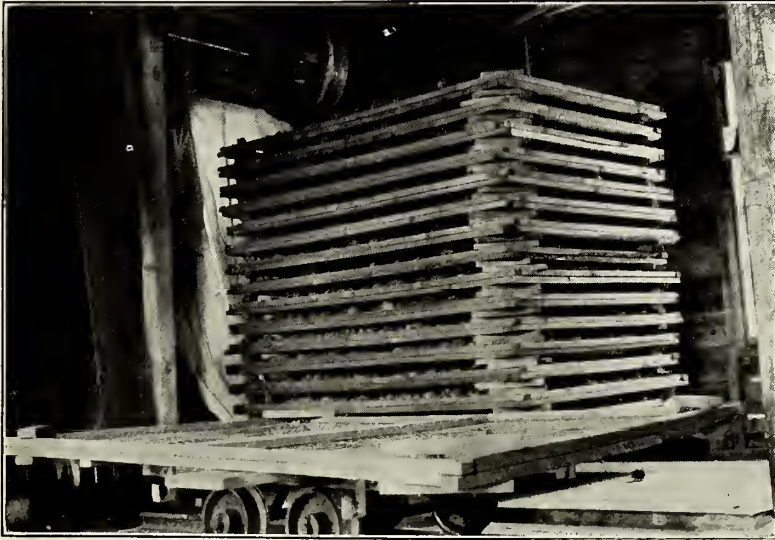

A CAR OF CONES ON ITS WAY FROM THE KILN TO THE SHAKER

and selects the plump, healthy, well-filled ones, cutting them at just the right time, when the seed is thoroughly ripe, but before the scales have begun to open. Squirrel storehouses are not easy to find. They are made in all sorts of places—by old, decayed logs, in springy and mucky ground, deep in forest litter, under bushes and the tops of felled trees, beneath the overhanging banks of streams, in almost any spot that affords good chance of concealment and safe-keeping. Sometimes a cache is revealed by scales, where the squirrel has been feeding, but often the hiding-places are at considerable depth and cleverly concealed under leaves and litter.

“What a cruel way to treat the squirrels,” you say, “to steal the food-supplies they have worked so hard to store away!” Really, how-

easily reached by a man, and good stocks of those varieties that the collectors in that forest are not seeking.

As the cones are collected before the scales open, they must be cured and dried. In some places, where the weather is very sure to be good, the drying is done in the sun, the cones being spread thinly on canvas



Photographs by courtesy of U. S. Forest Service

“CHURNING” THE DRIED CONES TO LOOSEN THE SEEDS



sheets that at night are drawn up at the corners and tied into bundles. Where there is much drying to be done or the weather can not be trusted, artificial heat is used. The drying-house is fitted with screen-bottomed trays, the mesh large enough to let the seeds drop through, placed one above another. For some kinds of cones it is better to use ovens where a higher temperature may be maintained, 135° for Norway-pine cones. When the cones are nearly all open, they are taken out of the trays and the seeds that remain in them threshed and screened out. To remove the wings, the seeds are sacked loosely and given a good kneading and rubbing, then put through a fanning-mill.

Most evergreen seeds are so small it takes a large quantity of cones to produce a pound of seed. A bushel of white-pine cones yields a little over a pound, of Norway cones about ten ounces, while sugar-pine, which has much larger seeds, averages a pound and a half, and lodge-pole pine only a quarter of a pound.

Among the important questions the Forest Service has to decide is where to sow the seed, what kinds give the best results in different soils and situations. White pine is the most valuable of our evergreens, but it requires good ground, while Norway is almost as valuable and can be grown in poorer soil. Jack-pine and scrub-pine are of much less value, but will grow in sand and gravelly soil, and spruce can be grown high upon mountain-sides, where pines will not grow at all.

The easiest way in reforesting is to sow the seed where the trees are to stand, and this is often done. The more valuable seed, however, such as Norway and white pine, is sown in nursery beds, and the seedlings raised with great care. The little trees grow slowly.

They are usually left in the seed-beds two years, then transplanted to another bed for a year or two more, before going to their destined place.

If this story of the gathering and planting of tree-seed has aroused in you some interest in the great work our Forest Service is doing, it has served its purpose. It would be a good task for the Boy Scouts, and the Girl Scouts, too, to help along the work of reforestation. Why not write to the Forest Service of the United States Department of Agriculture at Washington and ask for information about the planting and raising of trees that are native to your part of the country? For a few cents, the Forest Service will send you pamphlets telling you just what you want to know. Then select a bit of waste ground to seed, or prepare your nursery beds, and gather a supply of cones, nuts, or other tree-seed.

A few words of warning, though: don't gather more seed than you are going to use, follow instructions exactly, and remember that trees grow slowly. If you begin a nursery, be prepared to carry on the work for several years until your trees are large enough to care for themselves. Don't be discouraged if many of them fail to grow and flourish. Raising trees is like raising anything else, there are bound to be difficulties and disappointments. But if you go at it in the right spirit, you will find the work decidedly interesting. It will prove well worth doing if some day you can point to a grove of flourishing young trees, growing where no trees grew before, and say proudly, "Our patrol raised that grove from the seed." Try it, if you are sure you have the pluck and persistence to carry it through. If you are not sure, let it alone.



LODGES OF THE OJIBWA INDIANS, WHO GATHER THE CONES

# GOLF FOR BOYS AND GIRLS

*The Importance of Starting in the Right Way*

By CECIL LEITCH

Former British Women's Golf Champion

THE father of a young boy was heard to remark recently that he would not permit his son to play golf until he had left school, his reason being that he did not consider golf a suitable game for a child and believed in a boy playing cricket and football. He even went farther and stated that golf could be learned easily when his son had finished school. There are surely very few parents who would agree to this. Shortly after hearing the above opinion expressed we met a father who had already started his small daughter, aged five, to follow in his footsteps by giving her a club and a ball to play with. Most parents are anxious for their children to play golf, and to start in the right way. What is the right way for a child to learn to play golf? Should he have lessons from a golf professional, or pick up the game naturally?

Personally, I am in favor of the latter method, and it will generally be found that those who teach themselves become the better players in the end. The majority of children imitate the actions of their elders naturally, and if a child has opportunities of watching good golfers, he invariably becomes a fine player. We have innumerable proofs of this among the professionals who were originally caddies; and if we watch most caddies swing a club, we note that they generally do it with perfect action.

In choosing a youngster's first club I should always select a light iron. There are some teachers, perhaps, who would prefer a brassie, but I have always found that a boy or girl is inclined to top almost every shot with the latter. A stroke which sends the ball through the air has a certain fascination, and one can readily understand that this type of shot appeals to the youthful mind far more than the running ball.

Parents make a mistake in thinking that any old club, for which they have no further use, will do perfectly well for a child when cut down to a suitable length. It is most important that a youthful beginner should have a proper club, and not a clumsy head on a short shaft. A child's first club must be a perfect model of what he will use later. It is by no means uncommon to find a grown-up using

the club with which he first started, and using it particularly well and confidently. This would be impossible if the club had been a discarded, cut-down one.

Give a child a ball and a suitable club and



Underwood & Underwood

CECIL LEITCH PLAYING AT DEAL, NEW JERSEY

allow it to knock it about at will—with a few simple hints, such as keeping the right hand below the left and the eye on the ball. Nearly every beginner will argue that the reverse position of the hands is the more comfortable, but he must not be allowed to act accordingly. In the early days the young pupil will probably miss the ball more often than he hits it; but very soon "air shots" will be few and far between, and before long the ball will be hit cleanly and consistently. There is nothing more fascinating than watching the rapid progress of a young golfer, and the increasing keenness as the shots become longer. Although I hate to have to say so, I can not help admitting that boys, as a rule,



acquire much more smooth and convincing styles than girls. That there is absolutely no reason why this should be so is proved by two young English girls, who play at a well-known British golf-club. The short course at this famous club is a wonderful nursery, and the large membership of young golfers includes many promising players. One of these girls to whom I refer was a competitor in the girls' championship last year, and her perfect swing attracted the attention, and gained the admiration, of many severe critics.

Children living near this particular course little realize how fortunate they are, as few clubs allow juveniles to become members. My earliest golfing days were spent on a stretch of ground which has practically disappeared, as the result of an encroaching sea. It was there I started to play with one of the old-fashioned lofters and a guttie ball, accompanied on all occasions by my left-handed sister. Before long we were allowed to become members of the club, over whose links we had to learn how to deal with heather, sand, bent, and wind. To this severe training I put down my hard hitting. I mention these facts in order to point out that hard hitting is necessary, and every boy and girl should be encouraged to hit—not merely acquire a pretty swing. My own methods

are quite unorthodox and should not be imitated, but there are numerous players who combine force with style.

Seven years is the age at which a child should begin to handle a club; before that, a stick and a tennis-ball are suitable implements with which to train the eye and acquire a swing. Two small boys with whom we played in our earliest golfing days started in this way, and without a single lesson became fine players with splendid, powerful styles.

An adequate set of clubs for a child, up to the age of fourteen, is composed of a brassie, an iron, a mashie, and a putter. It is unwise for a young player to carry too many clubs, as he is inclined to become uncertain with them all and master of none. The better plan is to keep the number as limited as possible; then each club is regarded as a friend in which the player has absolute confidence.

Putting will probably be the department of the game in which a child will make the slowest progress, but this is not surprising, as it is almost entirely a matter of touch and quite a different stroke from any other.

As regards the grip, I have purposely refrained from giving an opinion, as this, to my mind, is a case of every one to his own taste, but the habit of putting both thumbs down the shaft is to be discouraged.

---

## THE BATTLE OF THE TREES

By EDITH DE BLOIS LASKEY

A HAZY autumn peace enfolds the crop-piled fields and farms,  
But there upon the forest slope the trees are all in arms!

The sumach Indian warrior chiefs, with feather crests aflame,  
Come leaping down the sunny glade, as once the Pequods came.

The maples charge in red and green, their highland plaids wind-blown—  
You almost see the bare knees gleam and hear the bag-pipes drone!

Where chestnuts blazon golden pride, they press to battle still—  
The chariots of ancient Greece careening down the hill.

The silver-armored birches their crusader pennants fly;  
And pines, like Egypt's archer host, stand black against the sky.

All khaki-clad, the stalwart oaks in veteran lines advance—  
They mind me of our own dear lads, who sailed away to France!

On, soldiers! Fight your bloodless war! For night will bring you soon  
To join the corn-stalk bivouac beneath the hunter's moon.

# THE INCA EMERALD

By SAMUEL SCOVILLE, JR.

*Author of "Boy Scouts in the Wilderness," "The Blue Pearl," etc.*

## SYNOPSIS OF PREVIOUS INSTALMENTS

PROFESSOR AMANDUS DITSON, the great scientist, has discovered the location of Eldorado, where for hundreds of years the Incas of Peru threw the best emeralds of their kingdom into the lake as an offering. The professor's ambition in life is to secure a living specimen of the bushmaster, the largest and most venomous of South American serpents. He calls on Big Jim Donegan, the lumber-king and gem-collector, and offers to lead a party to the lake if Jim will finance the trip, and to allow the lumber-king to have the emeralds, provided Ditson can keep the bushmaster. Jim promptly agrees to this, and Jud, the old trapper, Will, and Joe, the Indian boy, who together found the Blue Pearl for Jim Donegan, agree to go on the trip. Jud and Professor Ditson bicker as to who shall lead the expedition. A whip-scorpion decides the discussion in favor of the professor. They have adventures with birds, butterflies, and vampire-bats. Joe has a terrible experience with an anaconda, and Will is nearly swallowed by a giant catfish. They pass Treasure Rock and hear its story. They are shipwrecked, and lose all of their equipment. They have an adventure by night with a jaguar. They build a new boat and start on down the river. Pinto, Will, and Jud are treed by peccaries, Will is driven down to the ground by fire-ants, and his life saved by a black jaguar. They come to the Slave Trail, which runs to the lost Lake of Eldorado, and meet a war-party of man-eating Muras. On the shores of a forest lake they have adventures with a cougar, an alligator, and piranhas. They find a little Indian girl lost from her tribe. Jud is upset by an armadillo, while Will catches a bushmaster and escapes an army of carnivorous ants by a narrow margin.

## CHAPTER X

### SKY BRIDGE

AT the end of their next day's journey, the Trail began to swing away from the jungle, and thereafter led ever upward, skirting the foot-hills of the mountain-ranges beyond which lay the lost cities of the Incas. Three days after Will's escape from the pit he found himself once more in terrible danger. During the rest-period at noon, he had walked away from the rest of the party to see what new birds he might find. Not far from the camping-spot he came to where a colony of crested black-and-gold orioles had built long, hanging nests of moss and fiber among the branches of a low tree. Curious to see whether their eggs looked like the scrawled and spotted ones of the northern orioles, Will started to climb the tree. Before he was half-way to the nests, a cloud of clamoring birds were flying around his head, and as he looked up he noticed for the first time, directly above him, a great, gray, hornets' nest. Even as he looked, one of the circling birds brushed against it, and a cloud of enormous red wasps poured out. They paid no attention whatever to the birds, but flew down toward Will, who was already scrambling out of the tree at full speed. Even as he reached the ground two of them settled on his bare arm, and instantly he felt as if he had been stabbed by red-hot daggers. Never in his life had the boy known such agony.

Trembling with pain, he brushed the fierce insects off and rushed at top speed toward the camp. In spite of the heat, a racking chill seized him as he ran. His teeth chattered together, and waves of nausea seemed to run over his whole body, dimming his eyes and making his head swim. As he reached the rest of the party he staggered and fell.

"I've been stung by some big red hornets," he murmured, and dropped back unconscious.

"It's the maribundi wasp," said Professor Ditson, looking very grave, as he helped Hen undress the boy and sponge his tortured body with cold water. "Three of their stings have been known to kill a man."

By evening, Will was delirious. All night long, Hen and the scientist worked over him, and by the next day he was out of danger, although still in great pain and very weak. It was several days before he could walk, and then only with the greatest difficulty. At first every step was an agony, but Professor Ditson assured him that regular exercise was the best way to free his system from the effect of the maribundi venom.

Then death, which had dogged the travelers' trail for so long, peered out again at them. They had finished the first stage of their day's walk, and Will was lying white and sick under a tree trying to gain strength enough to go on. Ahead of them stretched a wide river with a ford showing, down to which the Trail led. Suddenly, from the depths of the near-by jungle, came a horrid



scream, followed by a chorus of baying notes, something between the barking of a dog and the howl of a wolf. As the travelers sprang to their feet, a shower of blood-red arrows, with saw-edged points and barbs fashioned from flinty strips of palm-wood, dropped all around them. Again the wailing, terrible cry broke the silence.

"It 's the jaguar-scream—the war-cry of the Miranhas," said Professor Ditson, quietly. "They are on our trail with one of their packs of wild dogs."

Even as he spoke, from the forest far below them a band of Indians broke into the open. Ahead of them raced a pack of tawny brown dogs nearly as large as the timber-wolves of the North.

Hen unsheathed his great machete, while Jud fumbled with the holster of his automatic.

"No! no!" said Professor Ditson, sharply; "we can stand them off better across the river. Hurry!"

Without a word, Hen picked up Will's limp body and raced ahead of the others around a bend in the Trail which hid them all for a moment from the sight of their pursuers. At the river the scientist suddenly halted, after a long look at the rapids which ran deep and swift on either side of the ford.

"Don't splash as you go through," he said quietly. "I 'll come last."

One by one the little party, headed by Hen with Will in his arms, waded carefully through the shallow water. As they went, Jud thought that he caught glimpses in the river of the squat, fierce forms of the dreaded piranhas; but if they were there, they paid no attention to the men who crossed with the utmost care. Just as Professor Ditson, the last of the party to leave the bank, stepped into the stream, there sounded with startling distinctness the same wild chorus which had come from the jungle. Once or twice in a life-time a hunter in South American forests hears the fearsome screech which a jaguar gives when it is fighting for its life or its mate. It was this never-to-be-forgotten sound which the Miranhas adopted for their war-cry. Down the slope not three hundred yards away came the hunting-pack. Right behind them, running nearly as fast as they, raced a band of some fifty Miranha warriors. As the fugitives looked back it was not the nearness of the wild-beast pack nor the fierce band of Indian warriors rushing down upon them which struck the color from the faces of Will and Joe. It was the towering figure of a man with a black bar of joined eyebrows

across his forehead and a scar on his cheek which twisted his face into a fixed, malignant grin.

"Scar Dawson!" muttered Will.

"Scar Dawson!" echoed Joe, despairingly.

As they spoke the outlaw seemed to recognize them, for he waved aloft a Miranha bow which he carried, and shouted hoarsely. By the time they reached the other bank, Will lay half fainting in Hen's arms.

"Fellows," he whispered, "I 'm all in. Hide me in the bushes here and you go on. There 's no sense in all of you sacrificing yourselves for me."

"We stay," murmured Joe, while Hen nodded his head and Pinto fitted one of his fatal little arrows into his blow-gun.

"Sure we 'll stay!" chimed in Jud, unslinging his automatic. "An' there 's seven Injuns who 'll stay too, unless I 've forgotten how to shoot. But what in the world 's the perfesser doin'?" he went on, peering out over the river.

Unheeding the tumult of howls and screeches behind him or the rush of the fierce hounds and fiercer men toward him, the eminent scientist was picking his way carefully through the ford. At the middle of the river, where the water ran deepest, he rolled up his left sleeve and, with his hunting-knife, unconcernedly made a shallow gash through the skin of his lean, muscular forearm. As the blood followed the blade he let it drip into the running water, moving forward at the same time with long, swift strides. Almost in a moment, the river below the ford began to bubble and boil with the same rush of the fatal hordes which had so horrified Jud and Will at the Lake of the Man-Eaters. As Professor Ditson sprang from the water to the edge of the farther bank, the water clear across the river seemed alive with piranhas. Unmoved, he turned to the rest of the party.

"That ford is locked," he said precisely. "For three hours it can not be crossed by man or beast."

Even as he spoke, the wild-dog pack splashed into the river. As they reached the deeper water and began to swim, the flash of myriads of yellow and white fish showed ahead of them. In an instant the water bubbled like a caldron, gleaming with myriads of razor-edged teeth. There was a chorus of dreadful howls as one by one the fierce dogs of the jungle sank below the surface, while only a few, gashed and bleeding, managed to swim back to the shore. From the farther bank came a chorus of wail-

ing cries as the war-party watched the fate of their man-hunting pack. Then, as if at some signal, the whole band threw themselves on their backs on the ground. Only the towering figure of the giant outlaw remained erect.

"What's happened to those chaps?" que-

Up and up they went until they disappeared from sight, only to come whizzing down again, from a seemingly empty sky, with such tremendous force and accuracy that they buried themselves deep into the ground just where the fugitives had been a minute before. Jud, who had lingered behind the



CHARLES LIVINGSTON BULL

"THERE WAS A CHORUS OF DREADFUL HOWLS AS, ONE BY ONE, THE FIERCE DOGS SANK BELOW THE SURFACE"

ried Jud, much perplexed. "I've been with Injuns nigh on to forty year, but I never see a war-party act that way."

As he spoke, Professor Ditson reached the summit of the slope where the rest of the party were standing and saw the prostrate band on the other side of the river.

"Hurry out of here!" he said sharply, gripping Will by the wrist and racing with him around a bend in the trail, followed by the others.

Their retreat was none too soon. Even as they started, each man of their far-away pursuers braced both his feet expertly against the inside horn of his bow and, fitting a five-foot arrow on the string, pulled with all the leverage of arms and legs combined, until each arrow was drawn nearly to its barbed point. There was a deep, vibrating twang which could be heard clear across the river, and into the sky shot a flight of roving shafts.

others, had a narrow escape from being struck by one of the long shafts.

"We'd have all looked like porcupines if we'd stayed there thirty seconds longer," he remarked to Joe, as he joined the rest of the party. "Them Miranhas are sure the dandy shots with a bow."

"Huh!" returned Joe, jealously, "that nothing. My uncle out in Akotan, where I come from, he kill a man with an arrow half a mile away, and no use his feet, either."

"That uncle of yours was some performer with a bow," returned Jud, cautiously. "Half a mile is good shootin' even with a rifle."

Further discussion was ended by Will. "Set me down, Hen," he demanded, "I think I am going to do a mile or so on my own legs."

"From here on, Pinto and I have been over this route," announced Professor Ditson. "Ten miles farther on is 'Sky Bridge.' If



we can cross that and cut it behind us, we 're safe."

Two by two the members of the party took turns in helping Will along the trail, which soon widened into a stone-paved road.

"This is one of the Inca highways," explained the scientist. "It leads from their first city clear to the edge of the jungle. Once," he went on, "the Incas ruled an empire of over a million square miles, equal to the whole United States east of the Mississippi River, but they never were able to conquer the jungle."

The road sloped up more and more steeply and the going became increasingly difficult, but Professor Ditson hurried them on remorselessly.

"The Miranhas never give up a chase," he said; "and if they have succeeded in crossing the river above or below the ford, they may be even now hard on our heels."

Before long they were in a wilderness of bare, stern peaks, whose snow-covered summits towered high against the horizon. At times the road zigzagged along narrow shelves cut in the faces of precipices and guarded here and there by low retaining walls built of cut stones laid without mortar, but so perfectly that the blade of a knife could not be thrust between them. The air became colder, and the scientist told them that often the temperature in these mountain valleys would vary as much as one hundred degrees within twenty-four hours. As they approached the crest of a great ridge which towered above them, Jud suddenly began to find great difficulty in breathing and complained of nausea and a feeling of suffocation.

"It 's the *soroche*, the mountain-sickness," explained Professor Ditson. "It will pass soon."

"I 'm the one that 's goin' to pass—pass out!" panted Jud.

Soon he became so exhausted that, like Will, he had to be half carried along the trail. "You an' me are a fine pair to fight Injuns," he whispered to the boy, who only smiled wanly in reply.

Beyond the ridge the road ran downward toward a vast gorge. From its dark depths rose and fell at intervals the hoarse, roaring bellow of a river rushing among the rocks a thousand feet below.

"It is Apurimac, the Great Speaker," said Pinto.

As the Trail led downward again, Jud began to feel better and before long he was able to walk without any help.

At length, far below them, looking like a white thread against the threatening blackness of the cañon, they saw swinging in the wind a rude suspension-bridge of the kind which travelers had used in these mountains ever since the days of the Incas. When Pinto, who knew the bridge well, learned that Professor Ditson intended to cross it at once he was much disturbed.

"No one, Master," he protested, "ever crosses it except at dawn before the wind comes up, nor should more than one at a time pass over it."

"To-day," returned the scientist, grimly, "you are going to see six men cross this bridge in the middle of the afternoon, wind or no wind; and what 's more, they are all going to cross together," and he waved his hand toward the road along which they had come. Against the white side of the mountain, which the Trail skirted, showed a series of black, moving dots, while down the wind, faint and far-away, came the tiger-scream of the Miranhas. They had found a way to cross the river, and once more were hard on the heels of the treasure-hunters. Along the Inca road the little party hurried at break-neck speed. At one place their way ran between a vertical wall of rock and a dizzy precipice. Farther on, it led down by rude stairs partly cut in the rock and partly built out of stones. At one point it made a sudden turn, with a low parapet built around it in a semi-circle to keep descending travelers from slipping off into the depths below from their own momentum. Once beyond this last danger-point, the fugitives found themselves before Sky Bridge itself. So deep was the cañon that from the river a thousand feet below the bridge seemed on a level with the clouds and well to deserve its name. It was made of two vast cables, woven out of braided withes, which stretched nearly a hundred yards from bank to bank of the gorge. Between and below these ran several smaller cables fastened to the upper two, which served as guard-rails. Sections of cane which were laid transversely across the three lower cables and tied on by strips of rawhide, formed the flooring, which swung four and five feet below the upper cables. From far below came the stern roar of the Speaker, and at the bottom of the sunless gulf gleamed the white foam of the river as it raged against masses of rent and splintered stone. Over the abyss the bridge waved back and forth in the gusts which all day long swept through the gorge. At times, when



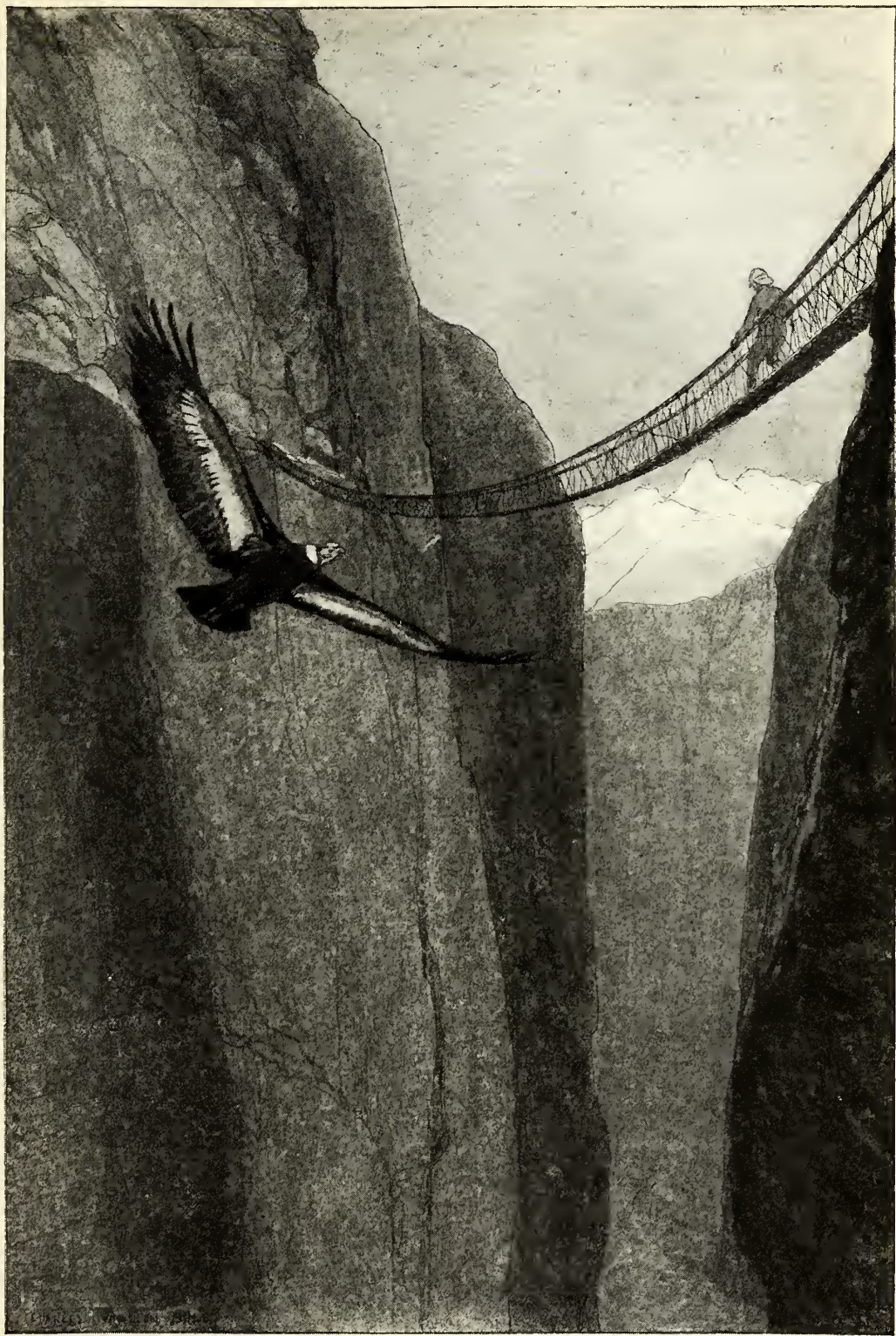

"THE CONDOR GAZED EVILLY UPON THE MAN CLINGING TO THE SWAYING BRIDGE"



the frail structure caught the full force of the wind, it swung fully ten feet out beyond its center, hung a second, and then dropped back with a jar that threatened to snap the cables or hurl into the abyss any one crossing.

Not for all the treasure of the Incas would any one of the party have risked the crossing. The fear of death, however, is a great incentive to brave deeds.

"I'll go first," said Professor Ditson, suddenly, "and see if it is possible to get over. Unless we cross this bridge within the next fifteen minutes, we are all dead men."

Without further speaking, the scientist stepped out upon the swaying bridge and gripped the twisted cables, firmly fixed in buttresses of stone. At first he shuffled along with short, cautious steps. In front of him the footway of wooden strips sloped away sharply clear down to the swaying center of the bridge. From far below, up through the mists which half hid the river, soared a bird the size of a pigeon. As it circled up through a thousand feet of space it seemed to grow and grow, until, by the time it reached the level of the bridge, rocking on mighty, motionless wings, it showed itself as the great condor of the Andes, one of the largest birds that flies. From its grim, naked head its cold eyes gazed evilly upon the man clinging to the swaying bridge, and then turned toward the little group huddled against the side of the precipice, as if counting them as additions to its larder of death. As the great vulture swept by, blotting out a stretch of sky as it passed, the wind hissed and sang through the quills of its enormous wings, taut and stiff as steel. Rocking, swaying, perfectly balanced in the rush of air that howled down through the cañon, the bird circled over the bridge and then, without a flap of its vast wings, dipped down into the depths below until, dwindling as it went, it disappeared in the spray of the prisoned river. No other sight could so have plumbed for the travelers the depths that lay beneath the bridge. For a moment the scientist clung sick and giddy to the swaying cables that seemed to stretch tenuous as cobwebs across the sheer blackness of the abyss.

"Come back, Master!" called Pinto. "No man can cross that bridge."

"No man will live who does n't cross this bridge," returned the professor, as the wind brought again to their ears the war-cry of the Miranhas. Bending double and clinging desperately to the ropes woven from tough maguay fiber, he edged his way down the

swaying slope, while the others watched him as if fascinated. At times the full force of the wind, as it was sucked down through the long cañon, swung the bridge out so far that he had to lie flat and cling for his very life's sake. When at last he reached the lowest part of the curve, instead of climbing on up to the safety of the opposite shore, the scientist deliberately turned around, and taking advantage of every lull and pause in the sudden gusts which bore down upon him, began the long, steep, slippery climb back to the point from which he had started.

"He 's riskin' his life twice to show us the way," said old Jud, suddenly. "Come on! I'm more ashamed to stay than I am scared to cross."

Foot by foot, clinging desperately to the sagging, straining cables, Professor Ditson fought his way back. When at last he regained the safety of the cliff-side his face was white and drawn and he was dripping with sweat, while his hands were bleeding from the chafing of the ropes; but there was a compelling gleam in his eyes, and his voice, when he spoke, was as precise and level as ever.

"I have proved that it is perfectly possible to go over this bridge in safety, and I believe that the cables are strong enough to hold the weight of us all," he said. "I will go first. Hen will go last. Don't look down. Hang on. Watch the man ahead, keep on going, and we'll get over—just in time." And he stretched his gaunt arm toward the Trail, where now the Miranha band was in plain sight not half a mile away.

Again he turned and started out over the bridge that swayed and swung above the death that roared for them far below. Without a word, but with teeth clinched grimly, Jud tottered after him, his long gray beard blowing in the wind. Next came Pinto, shaking with fright, but with a habit of obedience to his master stronger than his own conviction that he was going to his doom. Joe followed, and between him and Hen, who brought up the rear, was Will. As the full force of the wind struck the swinging structure, now loaded with their united weight, the taut cables and ropes creaked and groaned ominously while now and again some weakened fiber would snap with a sudden report like a pistol-shot. Down and down the first terrible incline crept the little train of desperate travelers. There were times when the bridge would swing so far out that only by clinging and clawing desperately at

the guard-rope could the travelers keep from being tipped into the depths below. When that happened, each would grip the one next to him and, with linked arms and legs, make a human chain which gave and swung and held like the bridge itself. At last they reached the low-slung center of the bridge and caught the full force of the wind which howled down the gorge like a wolf. For a long minute they lay flat on their faces as the bridge swung forth and back like a pendulum. As the gust passed, they heard close at hand the tiger-scream of the Miranhas rushing at headlong speed down the Trail as they saw their prey once again escaping. Up the farther slope, crouching low and gripping desperately, with twining hands and feet, the fugitives pressed on foot by foot. At the worst places, Will felt Hen's mighty arms holding him tight to the swinging ropes; and from ahead, Joe risked his own life time and again to stretch out a helping hand to his friend. By inches, by feet, by yards, they wormed their way up, until Professor Ditson was able to get a firm foothold on the side of the cliff, where a narrow path had been cut in the living rock. Even as he struggled to his feet, the war-party dashed around the sharp curve which led to the entrance of the bridge. With all their courage and relentless vindictiveness, the Miranha band hesitated to cross where the white man had gone. As Jud and Pinto joined Professor Ditson on the little platform of rock which towered above the cañon, they saw their pursuers actually turn their heads away from the deep that opened at their feet, after one glance along the narrow, swaying bridge by which alone it could be crossed. Then, with a fierce yell, they dropped their bows and, whipping out

long, narrow-bladed knives from their belts, fell like furies upon the tough woven cables anchored among the rocks. It was Jud who first saw that they were trying to cut the bridge.

"Hurry for your life!" he called down to Joe, who, holding on to Will with one hand, was slowly hauling himself up the last few feet of the steep ascent. Even as he spoke, the taut cables began to quiver and sing like violin-strings, transmitting with fatal clearness every cut and slash and chop of the destroyers at the other end. Will was half-fainting with the strain of the crossing, which his weakened body was not fitted to endure long. Jud's shout seemed to pierce the mist of unconsciousness which was slowly closing over his head and he struggled upward with all his might. In another minute, Joe was near enough to be reached by the party on the landing, and three pairs of sinewy arms gripped him and pulled him upward, clinging to Will as he rose. Below him, Hen, bracing both feet, heaved the boy upward with the full force of his mighty arms. Just as Will reached the refuge of the cliff, with an ominous snapping noise the bridge began to sag and drop. Hen gave a desperate spring and wound one arm around a little pinnacle of rock which stood as a hawser-post for one of the cables, while Pinto and Joe gripped his other arm in mid-air and pulled him to safety just as the far end of the bridge swished through the air under the knife-strokes of the Indians. As, doubled by its drop, the full weight of the cut structure fell upon the strained cables, they snapped like threads, and cables, ropes, and footway rushed down into the abyss with a hissing roar which died away in the depths a thousand feet below.

(To be continued)

---

## JINGLES

### MERRY-GO-ROUND

MERRY-GO-ROUND, go round, go round—  
 Merry-go-round, go round!  
 Johnny shall ride on a prancing horse,  
 Jack, on a hunting hound:  
 Baby shall ride in a gilded coach—  
 He is too small to stride—  
 Merry-go-round, go round, go round;  
 Give us a jolly ride!

*Mabel Livingstone.*

### AN APT SCHOLAR!

'RITHMETIC is just like play!  
 I 'm beginning it to-day.  
*One*, is me alone, says Mother;  
*Two*, is me and little brother;  
*Three*, is when we carry dolly;  
*Four*, is us and Sister Polly.  
 Hear me count—one, two, three, four!  
 Some day Mother 'll teach me more.

*Ellen Manly*



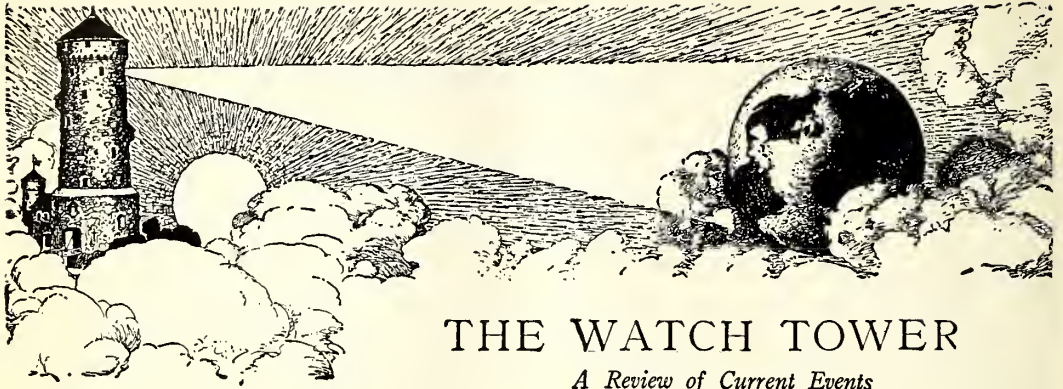

## THE WATCH TOWER

*A Review of Current Events*

By EDWARD. N. TEALL

### THE MINER, THE RAILROAD MAN, AND THE REST OF US

THE summer of 1922 was made memorable by two great strikes, those of the coal-miners and the railroad men. Progress in after-the-war readjustment was checked by these disorderly interruptions. For hundreds of thousands of workers can not lay down their tools, at a time when productive labor is even more than ordinarily needed, without threatening the nation's well-being. A civil war with armies in the field could hardly be more disastrous.

In the railroad strike, "seniority" came to be the issue about which the argument centered. Seniority is the ranking of the men according to length of service. If men are to be laid off, those at the bottom of the list are first to go. The higher a man stands on the seniority list, the safer he is against loss of work. You can easily see that this is a most important consideration.

Railroad men who went on strike, refusing to accept the Railroad Labor Board's ruling on wages, gave up their jobs—and forfeited the privileges they had earned by service. They were not driven out of their jobs; every effort was made to keep them at work, with assurances that fair play would be given. But the men refused to work, abandoned their jobs, and waited for the railroad managements to surrender to them and take them back on their own terms.

The railroads hired new men, and promised that *they* would be given seniority, and that strikers coming back would be placed at the end of the list, exactly as though they were new men. This seems to us not only fair and proper, but inevitable. And, once these

pledges were made to the new men, we do not see how the railroads could have afforded to break their word. To have done so would have been both unjust and foolish, for in later strikes it would be impossible to get new men to take the places of strikers if they were only to be hired temporarily.

Transportation is not only an essential industry, it is vital. Without it, the country cannot live. Food has to be brought into the cities, goods in trade have to be carried from place to place. Fuel has got to be transported from mine to furnace. This brought the two strikes, rail and mine, into close relationship as a concern of the national public.

The President tried to settle the two strikes. He was criticised by some for being tyrannical, too severe; and by others for being too "easy." Criticism of an umpire's decision from both sides makes it seem, to friends of fair play, presumably just.

In midsummer it was reported that business was good. The public was rather careless. People "in bulk" are slow to realize the need of alertness and action. When the mills are running, shops busy, markets active, we do not think what will happen to-morrow. But the money that business concerns receive to-day is in payment for services rendered and goods sold yesterday. To-day's work will bring in to-morrow's profits. And if we find, to-morrow, that there is nothing to work with,—or plenty to work with, but no way to move the goods to market,—why, then we know that day-after-to-morrow is apt to be a bad day for us! And you can laugh at a coal strike in August, but if the coal does not come out of the ground in summer-time, how are the bins to be filled when cold winds begin to blow?

The situation in midsummer of this year was as serious as anything this country ever faced. As this WATCH TOWER was written, there were few who would have cared to prophesy what might be expected by the time it would be read. We could understand only that America was being put to the test, and that it was a time for the sturdiest, clearest-thinking, and most loyal qualities of our national character to be called into play.

Perhaps you will be surprised at the suggestion THE WATCH TOWER has to make to its readers. We cannot say just what the Government ought to do, just what the union leaders and members ought to do, just what the great formless public ought to do. But we know that all these questions lead back to one center, and that is the individual citizen. And we do not know anything a citizen could do better calculated to make him or her a more useful citizen than

to go to the library and get a copy of "The Federalist," the papers of Hamilton, Madison, and Jay, first published when the Constitution of the United States of America was up for adoption by the States, and study those luminous pages carefully. After such study you will know better what true Americanism means for the worker, for the citizen, for the governmental officer.

### SHOULD WE CHANGE OUR SCHOOL SYSTEM?

OUR American institutions are made for the service of the people. Our methods of government are elastic. That is one reason why they sometimes seem to cause unnecessary confusion; it is also one reason why they are so strong, so satisfactory in the long run. They allow for expression of opinion, for full debate; and while the debate is on, we appear more or less to be floundering and blundering. But they also permit of compromise and adjustment, so that after the

debate is finished we can act in the way best suited to all the widely varying interests involved. A more rigid system might produce decisions and results more swiftly and more quietly, but the results would probably be less satisfactory.

Americans not only are not afraid of change, they seem to thrive on it. Our

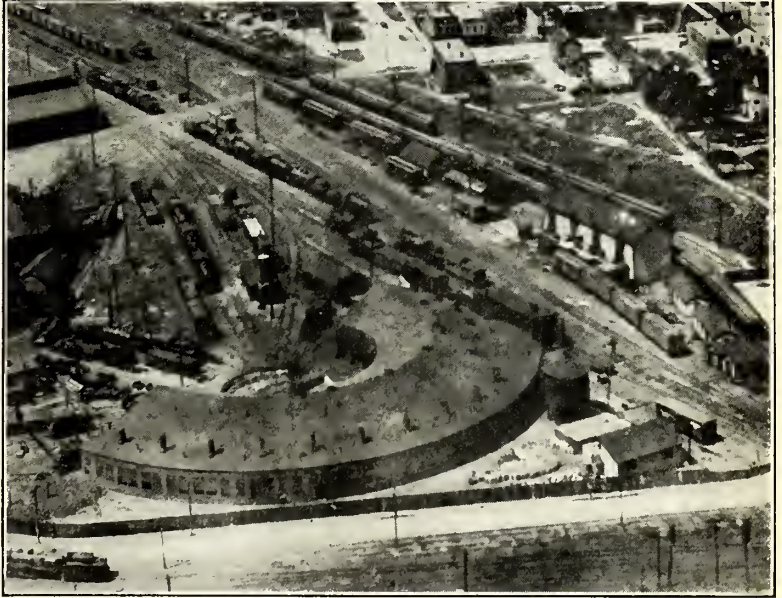

F. & A. Photo

ROUNDHOUSE IN CHICAGO, SHOWING ACCUMULATION OF CARS AND LOCOMOTIVES AWAITING THE REOPENING OF REPAIR-SHOPS

danger is not from fear of new things, but from the restlessness that makes men take up new ideas just because they are new, without thorough investigation. Just now there is a strong tendency for city governments to look to the state governments for authority, and for state governments to let the Federal Government rule, where the States themselves should decide and act.

Some of our readers will be pleased, some will be vexed, when we say that, in our view, the proposal for federal supervision of public schools is not desirable. There are too many bureaus and department divisions at Washington now. The States always have taken care of public education, and it seems to us that that is the best way.

The Towner-Sterling Bill, which had some public discussion during the summer, called for the creation of a department of education.

We are not such old fogies that the mere idea of a new department fills us with fear. No doubt there were persons who objected when the departments of labor and



commerce were organized. Those departments were created to take care of great national interests.

Somehow, education seems to us to call for different treatment. Perhaps we are wrong, perhaps we are right. We are not trying to tell our readers what they should think. We are only trying to get them to think carefully before taking a stand on this matter of universal concern. We believe the line between state responsibilities and federal responsibilities is getting blurred, and that it ought to be kept clear and sharp.

School departments are supported by taxes. When they are conducted by the States, they are closer to the people than when they are under national management. A federal department of education would be less favored by the States which now have good systems than by those whose schools are not so good, because the money collected from the citizens of all the States would be spent, no doubt, mostly in those States which have thus far done least for themselves.

We do not say that even this argument is final and conclusive, though we do attach great weight to it in arriving at our own conclusion. Possibly the strong States ought to contribute to the national total of strength by helping the weaker or less liberal States. This is in line with modern tendencies. Is it good Americanism?

#### ARTHUR GRIFFITH AND MICHAEL COLLINS

THE WATCH TOWER admires intelligence. It admires sincerity even more than intelli-



International

MICHAEL COLLINS AND ARTHUR GRIFFITH

gence. And it admires courage even more than intelligence or sincerity—or the two

together! Courage is the foundation of everything good in a man's life.

Arthur Griffith, president of the cabinet of the Irish Free State, had intelligence, sincerity, and courage. His death, August 12, was a shock to all who love patriotism.

Ten days later, Michael Collins, commander-in-chief of the Free State army, was killed by "irregulars," from ambush.

Griffith and Collins lived and worked for Ireland. At the time of their death the Republicans were cutting the cables between America and Europe, and Free State forces were completing a successful campaign in defense of the new freedom of Ireland.

Beyond these disturbances Griffith and Collins saw, we are sure, peace for Ireland; and we have faith that their dream will "come true."

#### CORN AND PROSPERITY

IN the springtime we hear that the crops will be bad. There is too much rain, or there is not enough rain. Early plantings are nipped by frost, or dried up by unseasonable heat. Farmers are in despair; consumers get ready to pay high prices for food.

Summer comes, the fields are green with growing wheat and corn, and still the papers are full of gloomy stories. Too much wet weather—the hay crop is doomed! Too much dry weather—grain is parched!

And then the summer passes, autumn is at hand, the Government studies the condition of standing crops and—predicts a wonderful harvest! It's an old, old story. This past summer's chapter came to a comforting close with reports of an expectable yield of three billion bushels of corn, the largest hay crop ever, the second greatest yield of potatoes in history, twice as many apples as last year, and plenty of wheat.

What a bin it would take to hold those two hundred million bushels of apples! How many corn fritters could be made from three billion bushels of loaded cobs? Forty million bushels of potatoes laid end to end—how many times would they reach to the moon and back? And if all those 679 million pounds of peanuts were one peanut, what a great peanut that would be!

It does "sort of" seem as though Nature were trying to be friendly and to help us along. And it seems as though we ought to manage better, with all these riches prepared for us, in getting them from the farms to the markets and from the markets to the con-



Copyright, Underwood & Underwood

GATHERING THE CROP IN AN OREGON APPLE ORCHARD

sumer's table. Some of the crops are perishable, and must be moved exactly when they are ready. California fruits ripened just when trains in the West were held up by the strike—or, to put it more fairly, trains were held up just when the rich crop was ready to be sent to the city markets of the East.

Some readers of *THE WATCH TOWER* who are planning their futures and do not feel attracted by the possibilities of school-teaching, or practice of law or medicine, or by shop or office work or engineering or professional baseball or preaching or newspaper writing or more ambitious literature, or aviation or soldiering or life at sea, might consider the opportunities that await the discoverer of new ideas in marketing.

Coöperative marketing has been tried. It consists of placing various producers' crops together, to be handled by a distributing agency which knows exactly what is wanted in the different markets, and sharing the returns in proportion to the percentage of each member's contribution. Such cooperation is practised among the fruit-growers of the Pacific Coast, and Eastern farmers have experimented with it rather satisfactorily. Potato-growers in New Jersey, for example, have found it helpful and profitable.

But this is a large country, and there are many regions of production and many mar-

kets in which the farmers compete. Along the line from the farm to the dining-room in the city there are many intermediate handlers of the foodstuffs. Each takes his bit of profit, increasing the final price. Each, presumably, renders some service; but there may be some cheaper and better way to get the fruits of field and orchard to the table.

Some of our *WATCH TOWER* boys and girls may be going to find that way. It would be a blessing to America!

#### CIVIL WAR IN ITALY

ON the last day of July, workmen in Italy proclaimed a general strike, in retaliation against the Fascisti's violent reprisals against the socialists in Ravenna. Not an easy sentence, that! But as you re-read it you will get the impression that it has been give-and-take in Italy; and the impression is quite correct.

In August the war between the Fascisti, upholding the Government, and the communists, opposing it, became so serious that five provinces were put under martial law. Hundreds were killed, thousands wounded. Finally, in mid-month, the Government issued a decree punishing 50,000 workmen who had taken part in the strike. Some of them were suspended, some dismissed.

Italy gave a demonstration of the method





Times Wide World Photos

PRINCE AXEL OF DENMARK, WITH  
HIS GRANDFATHER

International

PRINCE SUMI OF JA-  
PAN, A YOUNG  
ROYAL POET

Times Wide World Photos

THE FUTURE KING OF RUMANIA  
AND HIS MOTHER

YOUNG ROYALTIES WHO MAY FIGURE IN THE WATCH TOWER N—SAY—1942

of force in solving national industrial problems. It is a mighty expensive way to settle them.

THROUGH THE WATCH TOWER'S  
TELESCOPE

PERHAPS you smile when you read a newspaper head-line reporting that some group of Americans have formed a new organization to promote loyalty. "The war is over—what 's the point?" And then you see a head-line like this: "Soviet Leader Here to Stir Miners' War," and it begins to look different. It is a fact that agents from Moscow have been busy in this country, organizing communist societies. The day for Loyalty with a capital L (and a backbone) has not passed. We must actively defend America, still!

IN August, meetings were held in many of the large cities to celebrate the American Government's recognition of the Baltic republics, Lithuania, Latvia, and Esthonia, as states absolutely separate from Russia. Lithuanians in New York sent a message to President Harding, tendering "renewed pledges of devotion and loyalty to the United States, the mother of democracy."

THE Telescope refers you to the camera for some of its interesting discoveries this month. The three young royal personages shown, Prince Axel of Denmark, Prince Sumi of Japan, and little Prince Michael of Rumania, may be "written up" in THE WATCH TOWER of —say—1942.

A BELGIAN woman coming to this country with her young son to join her husband in Chicago got in eight hours ahead of the opening of the books for the Belgian 1922-23 quota, under the percentage immigration law. She had to go back to Belgium and return later. This seems like going pretty far with red tape, yet it may be that such strict enforcement is desirable, in spite of occasional inconvenience to new-comers. We ought to back our excellent restriction law with careful provision for rejection of ineligible persons before they start on their journey hither.

CHINA'S republican parliament met in August, after five years in which the gavel was laid aside and the sword and rifle used instead. At the very first session the members from the north and those from the south had a quarrel. The armies continued their argument in the field.

# NATURE AND SCIENCE FOR YOUNG FOLK

## TRAPPING INSECTS BY THE LURE OF LIGHT

THERE is an ancient proverb that the moth seeks the flame, and indeed it is a matter of common observation with all of us that a bright light attracts insects. This is particularly true of night-flying insects, since their vision is adapted to a dim light, and a very bright light, therefore, dazzles them and excites them, apparently, so that they fly directly into an open flame or strike violently against a covered one. Thus it is a common spectacle in towns surrounded by wooded areas to see the street-lamps surrounded by dancing swarms of insects; and often there is also to be seen a circle of solemn, but highly appreciative, toads squatted at the base of the post, enjoying the lavish supper thus provided.

A clever college-lad, James E. Cross, of Kenton, Tennessee, has made use of this long-observed fact to devise an ingenious insect-trap—a sort of Big-Bertha fly-trap. This invention, which has just been patented, consists, as our picture shows, of a large electric-light globe, surrounded by a large funnel connected with a flexible tube. At the base of the machine, suction is produced by a fan in the manner familiar to us in a vacuum-sweeper. An electric motor supplies the power for running the light and the fan. The globe illuminates a space of a thousand yards, and the insects within this space are attracted to its blazing light. Once arrived at the mouth of the funnel, however, they are irresistibly drawn within it and down the connecting tube by means of the powerful suction created by the fan. They are there collected in a suitable container, and can be readily destroyed by boiling water or other means when the "hopper" is full. Young Mr. Cross was led to invent this apparatus by a desire to help his father rid his cotton-fields of that terrible enemy, the boll-weevil. His apparatus was so successful in this, gathering up the pests literally by the bushels, that he now plans to make different models suitable to use in streets and in houses.

A curious parallel to the operation of this machine was observed by a friend of the writer at one of the big power-houses which draw energy by night and by day from the

stupendous floods of Niagara. Because of the heat from the great lights in the powerhouse, large electric fans are operated constantly in order to keep the machinery cool. Because of the attraction exerted by the lights upon insects, it is necessary to keep the doors and windows screened, and every

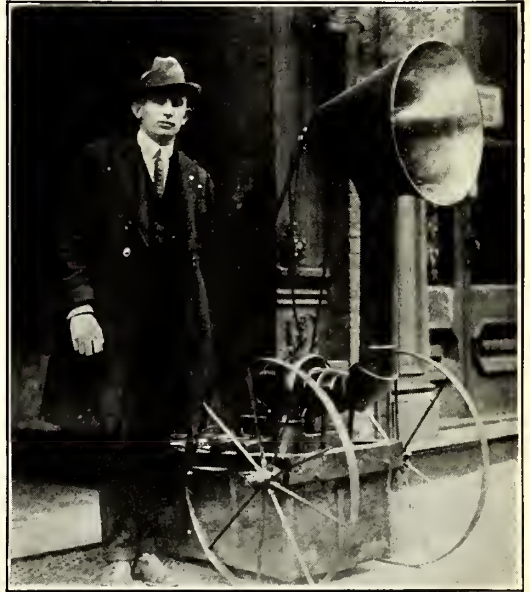

Keystone View Co.

"A BIG-BERTHA FLY-TRAP"

morning the ground is found covered with their dead bodies. Flying towards the light, they are caught by the suction from the electric fans inside and are held against the screens till exhausted.

## WHY LEAVES FALL

It is the poets who have taught us to consider the falling leaf as an emblem of decay and death, but there is no warrant for such an idea of nature. When the yellow leaf is caught by autumn gales and swirled far from its parent tree, or gently floats to earth through the still air, the process is but the prelude to new activities.

As the leaf lies upon the ground, myriads of microbes seize upon it and hasten its disintegration. What is of value is absorbed by the soil, and goes to form the nourishment of plant and tree that will blossom anew when spring returns. Here is no sad or use-



less death, but a natural process that makes for more life.

But what of the tree, shorn of its summer glory and now stretching its gaunt arms toward an inhospitable sky? Why must leaves fall? Nature is a wise mother and makes no blunders with her children. In the early days of spring the mysterious sap, so full of life-giving properties, began to creep upward. Gradually it spread to every branch and every twig, till it finally reached the opened leaves. The food that had been held in solution had been already taken up by the tree, and the leaves received the moisture not to keep, but to pass out into the air through the narrow openings in their upper and under surfaces. But this supply of sap could not go on forever. The source of supply would fail, the roots would become exhausted by their task, so there must come a pause. To leave the tree full of sap exposed to winter frosts would be to court disaster; as water freezes in the pipes and bursts them, so would the sap freeze in the branches and split them.

Accordingly, as the summer wanes, the tree begins to make ready for its annual rest. All that is of value in the leaf is withdrawn, and, in the process, the green coloring matter is changed to permit the formation of the gorgeous autumn tints. The sap sinks down into the branches and stem, to be stored in the roots and so keep the tree alive during the long winter days when no nourishment is being taken from the ground.

The leaf is now no longer of any use in its original position, and the tree has already prepared for the inevitable separation. A double layer of cells, called the separation layer, has been slowly formed between the leaf-stem and the branch, till at last it is complete, and the supply of sap effectually cut off. The leaf begins to dry and shrivel up, and the connection between leaf-stem

and branch is so weakened that the gentlest pressure brings about its fall.

When this happens, the cell layer divides, one sheet of cells remaining to heal the wound that would otherwise be left in the branch, while the other flutters to earth attached to the leaf-stem.

It is curious to note that some trees which lose their leaves in one land are evergreen in others. For example, the leaf of the plane-tree does not fall in Greece with the advent of winter, because there the climatic conditions are such that there is a plentiful supply of moisture all the year round. So, too, the peach is an evergreen in the oases of the Sahara, and the elder on the southern shores of the Black Sea.

MARK MEREDITH.

#### A DEADLY PARASITE

SOME of the most curious plants in the world are those that have adopted the habits of robbers. Perhaps the most singular of all is the dodder (*Cuscuta*), a parasite which sometimes becomes a dreadful pest to farmers. Although there are several kinds of dodder, the most destructive is that which attacks clover. Owing to the great rapidity with which the dodder grows, it is not uncommon for one plant to spread over square yards of ground and to destroy a great deal of the farmer's crop. The strange life history of this vegetable robber is an interesting one to follow.

The dodder that attacks clover is an annual, and all the winter its seeds lie in the ground. Here it may be mentioned that now and again the farmer may unknowingly sow dodder with clover seed. Farm seeds are not always very "clean" and often contain the seeds of various weeds. It is not until rather late in the spring that the dodder seeds begin to grow. From their point of view this is a good thing, for by



DODDER SHOOT SEEKING A VICTIM

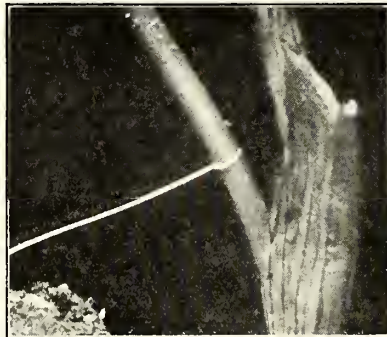

SECURING A HOLD



THE SHOOT DETACHED

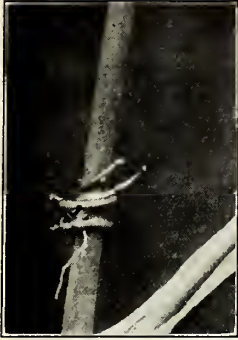

IT RAPIDLY ENLARGES



SEEKING FOR A FRESH HOLD



THE THREADLIKE SHOOTS INCREASING

then the clover plants will have made a good start.

When the dodder seed germinates, the first thing that happens is the appearance of a strange little club-shaped root. This buries itself in the soil. Then up comes a white thread, which grows with great vigor. It is worth noting that, apart from the moisture which it secures from the soil, the baby dodder lives entirely on the store of food packed away in the embryo. For a while the growth of the young dodder goes on very vigorously. The shoot may grow out to the length of a foot, or even more than this. All the time the upper part is working round in a twining fashion, just as if searching for something. Sooner or later it is likely that this stem will come in contact with some other plant. If this is a suitable kind for the attack, the robber will thenceforward be quite safe.

If, on the other hand, the dodder should be unable to find a host, it must die, for it can not lead a separate existence for more than a few weeks.



DODDER ATTACKING CLOVER STEM. (GREATLY ENLARGED)

The photographs which we use as illustrations show the manner in which a dodder attacks a clover plant. Notice how quickly the shoot of the dodder encircles the stem of its victim. Almost at once the parasite starts to develop suckers, which penetrate the tissue of the clover and begin to drain away the nutrient matter in the sap. As soon as the attachment is completed, the dodder plant dries up at the roots, and thenceforward it leads the life of a robber.

The rate of growth is prodigious, and soon even the strongest clover plant is overwhelmed. Not only is the draining power of the dodder very weakening, but the threadlike shoots increase so abundantly that the victim is practically smothered, for its leaves can not get light and air. All the while the dodder is extending in every direc-



THE PLANT TEN DAYS LATER

tion, and before its first victim has succumbed, the parasite has secured a fresh hold on neighboring plants. During the summer the dodder produces its clusters of white flowers, and these are followed by seeds.

An unusually wide distribution of the seed is brought about by the fact that it is shot with considerable force from the seed-cases as these become dry. So the life story of the dodder is completed.

S. LEONARD BASTIN.

#### A MOORING-MAST FOR AIRSHIPS

THE United States Army Air-service now has in use a new type of mooring-mast especially designed to be easily transported from place to place. It is made in four sections, each 18 feet long, and will properly handle ships from the smallest size, 35,000



cubic feet, to ships as large as the *Roma*, which had a capacity of 1,200,000 cubic feet.

It consists of a structural-steel tower securely held in position by steel cables. At the top of this mast is a cone-shaped buffer, properly pivoted; into this, fits the nose of the airship. A winch mechanism at the base of the tower reels in a cable that is passed up the center of the mast over sheave-wheels at the top and fastened directly to the nose of the airship.

The work of landing an airship and attaching it to the mooring-mast is relatively simple. As the airship comes near the mast, the mooring-line is dropped from an elevation of between 100 and 200 feet, and the

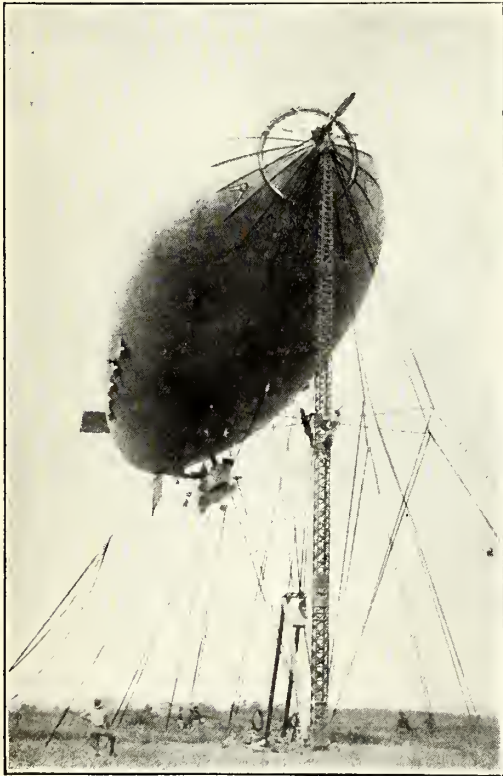

AIRSHIP ANCHORED TO THE MOORING-MAST

end of it is fastened to the end of the mooring-mast cable. With the winch in operation, the nose of the airship is steadily pulled up into the padded cone, and then the ship is anchored. Here it is secure from any damage from ordinary weather conditions. As this buffer is pivoted, the airship changes its position with any change of wind, as does a weather-vane.

GEORGE F. PAUL.

### THE PETRIFIED FOREST ON THE MOUNTAIN-TOP

UNLIKE the petrified trees of Arizona, which lie in the desert sands, the famous petrified forest of California is situated on top of a

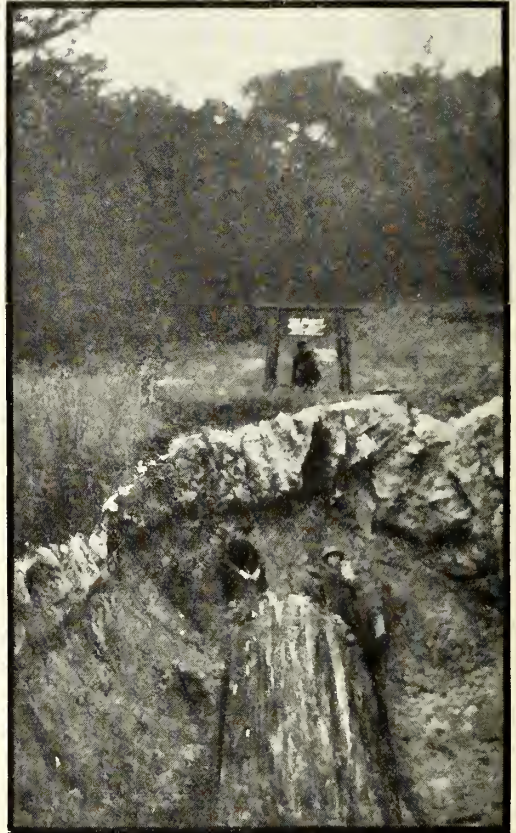

"THE GIANT," ONE OF THE PETRIFIED TREES PARTIALLY EXCAVATED

wooded elevation that rises a thousand feet above sea-level.

Calistoga, a hot-springs resort, is one point from which the petrified forest may be reached. It lies at the head of the Napa Valley, famed for its cherries and grapes, which are shipped in large quantities to the Atlantic Coast, while a few miles to the west lies the beautiful valley region that Jack London immortalized in his story, "The Valley of the Moon."

Napa Valley at this point is hemmed in on three sides by high mountains. Calistoga is thus the end of the railroad line, and travelers to points beyond must take the automobile stage. In this vicinity are found hot mineral springs, sulphur mud-baths, and at least three geysers that spout boiling water

at intervals of from thirty to forty-five minutes.

Two miles from Calistoga lies the prehistoric cause of the petrified forest, for Mount St. Helena, an extinct volcano, guards the northern end of the valley.

On a hot summer day this valley sentinel, with the sun beating down, looks anything but inviting—hot, metallic, and sullen; and the auto-stage that reaches the summit by a detour of about ten miles does not start until the cool of the afternoon. At one point near the summit of this dead volcano is a tablet placed by the Russians who once settled this part of California.

According to the scientists, Mount St. Helena, ages ago, was an active volcano; and all through the valley below, fragments of volcanic glass, known as obsidian, may be picked up in the fields. The Napa Indians fashioned it into spears, arrow-heads, and knives.

It was this volcano that, before the time of man, sent forth its terrible flood of lava and ashes, burying the giant Sequoias, the largest and most long-lived species of trees of the northern hemisphere.

Through the action of minerals, these buried trees became stone, or, as we say, petrified. Specimens, when cut and polished, make beautiful opalized gems for rings, pins, or brooches. They may be bought at the near-by "Forest Lodge," and each visitor on departing is given one of the rough specimens.

The owners of this petrified forest have built an inn that guards the entrance and have excavated about the buried Sequoias, erecting wire fences around them to preserve

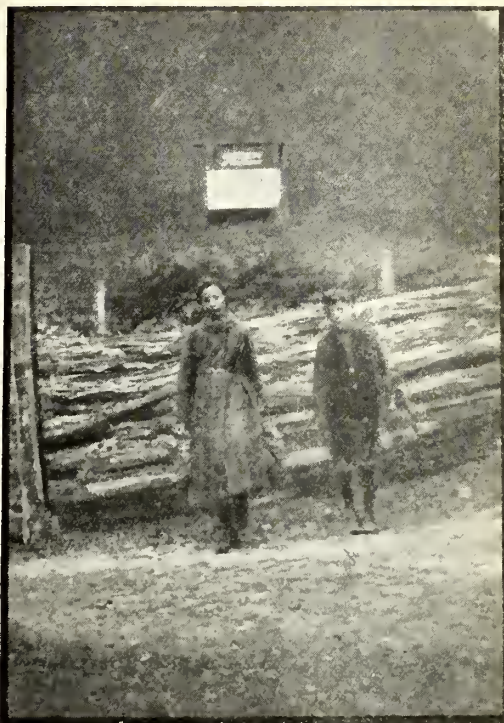

"THE QUEEN OF THE FOREST"

them from injury. Each tree has been given a distinctive name, such as "Queen of the Forest," "The Giant," etc.

One can not view the petrified forest and its surroundings without being impressed with the feeling of its great antiquity, and the reds and yellows of the madroño and manzanita on the mountain-sides lend vivid color to its natural beauty.

BRONTE A. REYNOLDS.



A PETRIFIED SEQUOIA, ITS END STILL BURIED IN THE HILLSIDE



## FOR VERY LITTLE FOLK

### THE HOUSE THAT PETER BUILT

By NINA HATCHITT DUFFIELD



#### PETER'S PROMISE

PETER PETER PUMPKIN EATER could n't please his darling spouse! Every day she plagued and pestered for additions to her house:



"MAKE IT HIGHER, BROADER, PETER!"

"Make it higher, broader, Peter, with some windows to the sun. Labor 's cheap in Cornfield Alley and I 'm sure it could be done. Let 's remodel it and paint it—it 's a poky thing, and plain; if 't were up-to-date and modern, then, my dear, we 'd entertain!"

Thus, the age-old plaint of woman pestered Peter's peaceful life, but like many a model husband he was bound to please his wife! So he made a solemn promise:

"Ere the frost of fall descends, you shall have your house, my lovey, and shall entertain your friends."

#### PETER'S HOUSEBUILDING

THROUGH the long and sizzling summer, Peter's planning grew apace, with the host of Cornfield fairies—architects—in friendly race. Raindrop Brothers took the contract to enlarge the outer walls:

"You will feel them bulge and broaden every time a shower falls!"

Sure enough, to great dimensions Peter watched his cottage grow, but his wife, to his amazement, soon pronounced it "bung-a-low."

Primly, Peter cut the windows with a corn-blade, sharp and green; made them broad and high and handsome, with a massive door between. Diamond windows for

the basement, in a prim and pretty row, solved the ventilation problem that was vexing Peter so. Sammy Sunsprite did the painting with his brush of golden sheen; left the surface gay and glowing, where it once was sober green.

"'T is, indeed, a charming dwelling—nothing like it could be bought. Now my wife will be quite happy,"—so the prideful Peter thought.

PETER'S PARTY

"Now, of course," said Mrs. Peter, as they rested in the shade, "we must have a lovely party. Seed-cakes, dear, and pumpkinade will be best, I think, to serve them," she confided to her spouse. "Anyhow, we 'll find it cheaper—the material 's in the house."

"It shall be a real housewarming; all the neighbors we 'll invite," answered Peter. "Why delay, dear? Let us have the thing to-night!"

So the friendly little Peter donned his best, and out he went through the streets of Cornfield Alley to proclaim his glad intent. Then the Cornfield folk and fairies—friendly hoppers, fireflies too, bouncing bugs, and pompous beetles hastened in—a happy crew!

ALL at once, there came a Creature called "the cow with crumpled horn"—followed by the freckled youngster who had found her in the corn. There he saw the monstrous pumpkin, where the revelers held their lark,

filled so full of flaming fireflies it was *glowing in the dark!* Through the open door and windows, fireflies lighted up the place,—made the pumpkin wink and twinkle like a fat and friendly face.



"IT WAS GLOWING IN THE DARK!"

"With my jack-knife I could make one in a jiffy, if I tried! Won't it be a jolly lantern with a candle stuck inside?"

. . . . .

WHEN you see a Jack-o'-lantern, with its saucy head a-tilt—pray remember, it was patterned from *the house that Peter built!*



"THEN THE CORNFIELD FOLK AND FAIRIES HASTENED IN—A HAPPY CREW!"



# ST. NICHOLAS LEAGUE



"WHEN THE CAMERA CLICKED." BY JANE I. NICHOLAS, AGE 14. (SILVER BADGE)

WITH this number of ST. NICHOLAS, the twenty-third year of the LEAGUE comes to an end. What a splendid year it has been, too! The members have "played the game" enthusiastically, fairly, and with wonderful results. Founded in Novem-

ber, 1899, on the eve of the twentieth century, the LEAGUE has grown in influence, inspiration, and interest every year. Boys and girls are daily enlisted under its banner, and these new recruits soon become seasoned veterans of the pen, brush, and camera.

Every instalment of the LEAGUE bears witness to the talent our boys and girls possess. We discover new geniuses in every competition, and feel like a modern Columbus—particularly this month of October, 430 years since his great discovery.

You'll enjoy each one of these eight pages as you turn and read through them, and discover for yourselves how interesting the whole budget is. For the active members of the LEAGUE, the last page, with its subjects for the next competition, will probably be the first one scanned; another instance of what is often the case, "the last shall be first."

As we look over the twenty-three years of the LEAGUE we are impressed with its wide range of subjects and the excellent way in which they have been handled. Subjects are, at best, little more than pegs on which to hang ideas, but these have served to support some admirable ones!

## PRIZE COMPETITION No. 271

(In making awards contributors' ages are considered)

**PROSE.** Gold badges, **Louise E. Alden** (age 16), Massachusetts; **Esther Girton** (age 14), Pennsylvania. Silver Badges, **Edith W. Huleu** (age 13), New York; **Edith T. Chauncey** (age 12), Maine.

**VERSE.** Gold Badges, **Lois Mills** (age 14), New York; **Eleanor C. Johnson** (age 14), New York.

Silver Badges, **Theodora Thayer** (age 16), Washington; **John McMillin** (age 12), Massachusetts;

**Myrtle E. Bullwinkle** (age 16), Vermont.

**DRAWINGS.** Gold Badges, **Marjorie A. Bly** (age 17), New York; **Yvonne Twining** (age 14), Canada.

Silver Badges, **Mary Kimball** (age 14), Missouri; **Elizabeth W. Enright** (age 14), Massachusetts.

**PHOTOGRAPHS.** Gold Badge, **Elizabeth Dargan** (age 13), South Carolina. Silver Badges, **Thelma B. Barr** (age 15), Illinois; **Caroline Humphreville** (age 10), Connecticut; **Edith Eardley** (age 11)

New Jersey; **Jane I. Nicholas** (age 14), California; **W. M. Behrend** (age 13), Rhode Island.

**PUZZLE-MAKING.** Gold Badge, **Walter Gutmann** (age 13), New York. Silver Badges, **Miriam Morse** (age 13), Missouri; **Alice Kerr** (age 14), Ohio; **Katherine G. Todd** (age 13), Louisiana.

**PUZZLE ANSWERS.** Silver Badge, **Cornelia M. Metz** (age 15), New York.

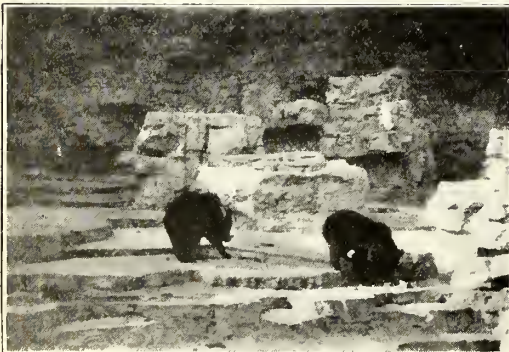

BY FRANKLIN MILLER, JR., AGE 9



BY EDITH EARDLEY, AGE 11. (SILVER BADGE)

"WHEN THE CAMERA CLICKED"



BY GWYNNE M. DRESSER, AGE 14. (HONOR MEMBER)

## "PLAYING THE GAME"

BY LOUISE E. ALDEN (AGE 16)

*(Gold Badge. Silver Badge won December, 1919)*

"I BELIEVE in honesty, sincerity, and the square deal; in making up one's mind what to do—and doing it."—ROOSEVELT.

WHETHER the game is baseball, basket-ball, tennis, or the greatest game of all, the game of life, there is only one way to play it—to play clean, to win fairly, to strive for a goal, and to "treat both those impostors, Triumph and Disaster, just the same."

Theodore Roosevelt, the delicate boy, the fearless Rough Rider, the strong President, and the American patriot played the game of life with a zest and vigor that should shame all of us who were born with healthy bodies. For although Roosevelt was handicapped with illness, in order to play the game and to give his best to the world, he determined to conquer his bad health. With remarkable perseverance, he did overcome it, and thus bequeathed to his countrymen and to the world the memory of a life lived as only a strong man with a sane mind and a healthy body could live it.

The books "Theodore Roosevelt's Letters to His Children" and his "Autobiography" vividly describe his victories over obstacles and his struggles in playing the game. Therefore, will not these books inspire the people of to-morrow as well as those of to-day to play the game of life?

Even now, many people are playing the game as Theodore Roosevelt did. Some are blind; others, deaf; and still more, lame; and yet they are playing life's game. Let us who are strong remember what they are doing, and with confidence join them in playing the game!

## THE TURN O' THE TIDE

BY ELEANOR C. JOHNSON (AGE 14)

*(Gold Badge. Silver Badge won January, 1922)*

THE tide is low and night is still and cool,  
The moonlight glimmers in a quiet pool  
And shines, all silv'ry white, across the sand.  
Deep shadows, velvet black, throng on the land.  
How still it is! Only the rippling waves,  
Born of the breeze, go whispering to their graves,  
Like slender, clinging fingers, which would reach  
A boulder gray beyond them on the beach.  
A moment more, they foam about the stone  
And claim it, seaweed covered, as their own.

Turn o' the tide! The magic of the night  
Enshrouds all things in mystery. The light  
Of many moons seems wavering in the sea—  
A thousand orbs, where only one should be.  
The waves creep on, with little swishing sigh,  
The beach is crescent-shaped. The tide is high!

## "PLAYING THE GAME SQUARE"

BY ESTHER GIRTON (AGE 14)

*(Gold Badge. Silver Badge won October, 1921)*

ARCHIBALD the Artistic had stolen Silver Serena's laugh! The news spread swiftly through Fairyland, causing dismay wherever it went.

Archibald the Artistic was the renowned painter of butterfly wings, a mischievous, but beloved, artist.

Silver Serena was an echo-elf, whose laughter was the joy and pride of all Fairyland, but particularly of her seven brother echo-elves.

"A HEADING FOR OCTOBER." BY DORIS E. MILLER, AGE 16  
(HONOR MEMBER)

Archibald the Artistic had discovered some Jerusalem cherries, and had invited Silver Serena to play croquet with him, using the small red spheres for balls. Silver Serena had gaily consented, and it was during the game that Archibald the Artistic had stolen the so-highly-prized silvery laugh.

All Fairyland was indignant. Archibald was a mischievous imp, as every fairy well knew, but never before had he done a thing like this. He had played many harmless pranks, but had never violated any important law of Fairyland. This was an outrageous crime. Small wonder that all Fairyland was aroused.

West Wind was sadly relating the story to a group of birch-tree dryads, when suddenly there sounded a silvery, clear laugh through the woods. West Wind exclaimed: "Silver Serena's laugh! That imp is hiding in this forest." Orders were promptly given to the breezes that they were to guard the forest and on no account allow Archibald to escape.

West Wind hurried to Sunset Gate, which was





BY M. AGNES MCPHILLIPS, AGE 13



BY SARAH DE FOREST, AGE 13



BY CAROLINE HUMPHREVILLE, AGE 10  
(SILVER BADGE)

"WHEN THE CAMERA CLICKED"

gleaming golden and crimson. Enough fairies soon volunteered to capture Archibald, and in a short time the repentant artist was a prisoner.

He was tried before Judge Goodfay, who sentenced him to sketch for a year for Jack Frost, a task which was far from being enjoyable.

So play the game square and do the right thing, for e'en in Fairyland, "your sin will find you out."

INDIAN SUMMER

BY THEODORA THAYER (AGE 16)

(Silver Badge)

THE sunny silent landscape stretches wide,  
Far on the distant hilltops fading dim  
Into a soft, blue haze. All nature rests  
After the summer's ceaseless struggle for life.  
Scarcely a sound disturbs the peaceful air,  
Save for the long monotonous, sleepy whir  
Of red-winged grasshopper, poising in the sun  
Above the yellow stubble, or the thump  
Of dead-ripe apple dropping from the tree.  
The brush along the little winding creek  
Is flaming orange-red, with here and there  
A mass of molten gold where willows gleam.  
And far above the quiet, tinted scene  
The blue sky stretches, cool and deep and wide;  
The crowning glory of a glorious world.

INDIAN SUMMER

BY ALINE FRUHAUF (AGE 15)

A MAIDEN with corn-gold hair  
Is dancing across our land;  
Her breath is the warm sweet air,  
And the ripe fruit falls from her hand;  
Her eyes are the lake's own blue  
Her laughter, the brook's—and as clear;  
She 's the Indian summer, it 's true,  
And the sweetest of all the year!

"PLAYING THE GAME"

BY EDITH W. HULEU (AGE 13)

(Silver Badge)

THE house was all in confusion, and Peggy sat in a corner and sulked. Mother was ill and had to go to the mountains for awhile. Peggy was to go to her Aunt Jane's farm. Just think! Peggy, who had always been spoiled in her lovely city home, living on a farm! Horrors!

Two days later found her at the little suburban town where her aunt lived. A flock of laughing children, dressed in bloomers and middies, romped in the fields. Peggy, in pumps and white silk stockings, a white skirt and pink sweater (it was 85° in the shade), sat on her bed writing. "Oh,

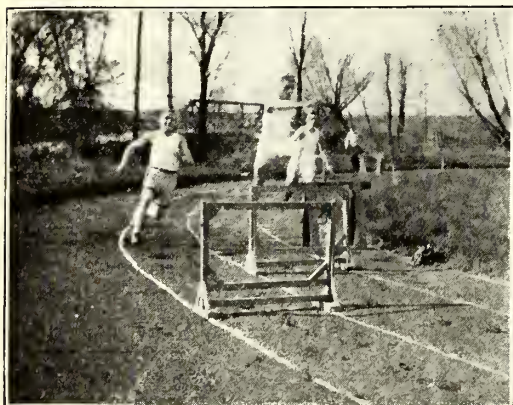

BY SALEM HYDE, 2ND, AGE 17. (HONOR MEMBER)



BY MARY H. ROBERTS, AGE 15

"WHEN THE CAMERA CLICKED"

Mother, I 'm so lonely, and every one 's so different,"she wrote.

The next day a telegram came. All it said was, "Try and play the game, Peggy. Mother."

Peggy sat thinking it over.

"It 's all my fault!" she burst out at last. "I 'm nothing but a prig! Now, let 's see if I have any decent clothes to wear."

She quickly donned a pair of bloomers, which her mother had wisely put in her trunk, a pair of old sneakers, and a middy. Rolling down her stockings as she went, she hurried out to play.

One night a week later, Peggy's mother was reading a letter from Peggy. She smiled as she read this paragraph to her husband:

"Just think, Mother dear, I am now wearing sneaks, bloomers, a middy, and socks (me with socks!), and I 've had my hair bobbed. I drink

### "PLAYING THE GAME"

BY EDITH T. CHAUNCEY (AGE 12)

(Silver Badge)

WE were sitting on the porch, my friend Judy Allen and I. "What shall we do?" Judy asked, for about the hundredth time. I answered that I did not know, and we relapsed into silence, for we were racking our brains for something to do.

Suddenly I was struck with an idea. "I have it!" almost shouted. "You know, your mother and my mother dressed as gipsies at that masquerade ball—well, we 'll put on those costumes and the wigs they wore and go out as gipsies. No one will ever know us." "Fine!" agreed Judy. So, after much pinning and sewing, we went out of the house, looking, for all the world, like two gipsies.



BY BETH WARD, AGE 12



BY ELIZABETH DARGAN, AGE 13. (GOLD BADGE. SILVER BADGE WON JULY, 1922)



BY THELMA B. BARR, AGE 15 (SILVER BADGE)

### "WHEN THE CAMERA CLICKED"

milk by the quart, feed the chickens, get up at 6:30, go to bed at 9:00, and *climb trees!* I play with the mayor's and the washwoman's children alike, and I *don't* want to come home except to see you. Mother, I believe I am learning to 'play the game.' PEGGY."

### INDIAN SUMMER

BY ELIZABETH GOW (AGE 13)

A PURPLE haze, a cobalt sky,  
The cries of the wild geese sailing high,  
The sparkling air, the willow shades  
Of mauve and mulberry in sunny glades  
Is Indian summer.

The hunter's moon, the halcyon days,  
One's only wish to wander through the maze  
Of tangled vines and crisping weeds,  
Hours slipping by like golden beads—  
All this and more is Indian summer.

We had n't walked far when we saw two bandits running toward us! They had pistols in their hands and were very rough looking. We started to run, but one of them yelled, "Stop or die!" We waited, shaking with fear, till they came up. Our wigs, which were naturally too large, because they were made for our mothers, fell off in our hurry to get away. The bandits, who by this time had caught up with us, stopped in surprise, laughed, and took off their masks. Then whom should we see but our brothers, Jack and Bob!

"Well, of all things!" said Jack, "they were playing the same game we were!"

### "PLAYING THE GAME"

(A True Story)

BY ELIZABETH BROOKS (AGE 14)

VERY early one morning soon after we arrived at our summer cottage, my aunt and uncle were awakened by a loud, continued rapping down-



stairs. Upon going down, they found a robin beating the window with his beak.

In a tree very near the east window was the robin's nest. As the sun rose he saw himself and also the tree reflected in the window; and, thinking it was another robin, he fought it to protect his family, which was the way he "played the game."

He was a fierce fighter, delivering terrible blows, and fought until he was exhausted, when he would fly back to the tree or the ground and rest, and



"AT WORK." BY ELIZABETH W. ENRIGHT, AGE 14  
(SILVER BADGE)

then make another fierce attack, but with the same results.

As we arose and moved about, the robin flew away. But the next morning and several mornings after, he came and fought as hard as before.

Finally, we covered the outside of the window at night, so that when the sun rose the robin could not see his reflection.

Although a bold fighter, he was a shy bird, and soon he and his mate left the nest and went away.

### THE TURN OF THE TIDE

BY JOHN McMILLIN (AGE 12)

(Silver Badge)

A STURDY runner from the north  
To haughty Sparta came,  
With a heavy, lagging footstep  
And a head bowed down with shame.

"Your chosen band is slaughtered;  
Leonidas, no more;  
Thermopylæ is taken—  
Can aught such loss restore!

Then sorrow was in Sparta,  
And sad the friends and wives  
Of those who there had battled—  
Of those who gave their lives.

But then again to Sparta  
Did the sturdy runner fly,  
With a step that showed no lagging  
And handsome head held high.

"Themistocles has triumphed,  
And Salamis is won,  
And Xerxes' plans are shattered,  
And the Persian march is done!

"Rejoice, rejoice, O Spartan!  
To Mars lift up thy voice—  
To Mars, the god of battle!  
Rejoice, O friends, rejoice!"

### "PLAYING THE GAME"

BY MARY SYDNEY BRANCH (AGE 13)

Full many a flower is born to blush unseen,  
And waste its sweetness on the desert air.

So in private life, many a one plays the game without credit or recognition. And our hearts are filled with pride as we read the biography of great men who have led a life of sacrifice and high endeavor and played the game to the end.

One of the most striking instances of playing the game is furnished in the life of the great novelist and poet, Sir Walter Scott. After he had written many works of genius and beauty, and had gained great popularity, a publishing firm, in which he had invested largely, failed, owing to the mismanagement of his partners. The debt of the firm amounted to about \$650,000.

Scott voluntarily assumed responsibility for the entire debt of the firm, rather than bear the ignominy of bankruptcy and permitting the firm's creditors to sustain a loss. Many men, in these circumstances, would have balked at assuming merely their share of the debt, but, Scott, although then almost fifty-five years of age, resolved to pay off the whole of the firm's obligations. He refused all offers of assistance from his friends, and courageously set to work with his pen to earn the money. Notwithstanding that he had a stroke of paralysis a few years later, followed soon after

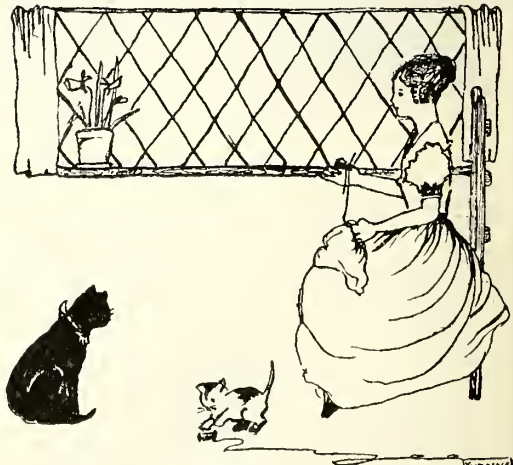

"AT WORK." BY YVONNE TWINING, AGE 14. (GOLD BADGE.  
SILVER BADGE WON OCTOBER, 1921)

by a slight attack of apoplexy, he fought bravely on, until death ended his heroic labors.

Oh, if we all, even in our humble way, could catch the spirit of Sir Walter Scott, and play the game to the best of our ability!



BY ELAINE WEGENER, AGE 13



BY MARGARET ATKINS, AGE 13



BY ELEANOR PHIPPS, AGE 13



BY FRANCES WORTHINGTON, AGE 13



BY MAC OLDS, AGE 10

## "WHEN THE CAMERA CLICKED"

## THE TURN OF THE TIDE

BY LOIS MILLS (AGE 14)

*(Gold Badge. Silver Badge won December, 1921)*

DID ever you watch from the top of a cliff  
 The turn of the wild free tide,  
 With silver water and golden sand  
 Stretching far and wide,  
 And tiny shifting currents, flecked with glistening foam,

Dashing against the black boulders there  
 Beneath the heaven's bright dome?

Oh, the turn of the tide,  
 Of the wild free tide,

On the eddying, shifting sand!

Did ever you watch in the moon's soft glow  
 The turn of the restless tide,

When the sea is as black as the sky above  
 And the light has long since died;

When the moon is reflected on the waves  
 In lines of silver-gold,

And the boulders black, like sentinels  
 Stand guard through ages old?

Oh, the turn of the tide, of the restless tide,  
 On the eddying, shifting sand!

Oh, the turn of the restless, wild, free tide  
 As it wears away the land!

## "PLAYING THE GAME"

BY ALICE STERLING (AGE 11)

MY great-great-grandfather was a missionary in the wilds of India, much loved by the natives because of his helpful ways. Except for his one servant, there was not a white person within miles of his abode.

For a week, there had been rumors abroad of a fatal sickness, which rumors finally came to the ears of the missionary one evening, when the servant broke into the hut crying, "Master, we must flee to-night, for the cholera is in this very village."

"John," said my ancestor, "take your donkey, and may God speed you to safety. As for myself, I shall stay and help the poor souls that now need me more than ever before. For," thought he, "should I, having taken it upon myself to do this task, give it up when danger threatens?"

For days he went among his people, cheering those who were sick and speaking words of comfort and hope to the dying.

One evening he noticed that he had a dizzy feeling. It was in vain to struggle against the dreaded sickness, for soon he sunk into a heavy stupor in which he lay for hours. Then the door opened quietly and John, the servant, entered, followed by two learned doctors. In some way, they had







BY MARY KIMBALL, AGE 14. (SILVER BADGE)

## ROLL OF HONOR

A list of those whose contributions were deserving of high praise:

### PROSE

Ruth Hannah  
Tranum  
Norma L.  
Sherburne  
Julia Fairchild  
Mary Stevenson  
Alice May Kistler  
Arlene McPheters  
Kathrine Jerome  
Edward L. Carroll  
Sarah Jane Taylor  
Martha McCowen  
Alice McNeal  
Leon Kalman  
Stewart North  
Shirley Armitage  
Edith May Witt  
Eleanor Martin  
Edith G. Kline  
Rose S. Lancaster  
Hazel Kuno  
Frances S. Miller  
Maria Fletcher  
Esther Espenshade  
Gladyes Barnes  
Mary Plagg  
Margaret Siegel  
Mary Hoyt  
Stoddard  
Mary Caroline  
Bentley  
Theodora Maltby  
Ruth Hincheliff  
Barbara Simison  
Lucy Coburn  
Sanborn  
Malvena Fried  
Alice Buell  
Florence Roeveer

### VERSE

Betty Fry  
Betsy Rosenheim  
Elizabeth Brooks  
Anne Marie Honier  
Elaine Babcock  
Elizabeth McSwain  
Sally Miller  
Susan Clayton  
Caroline G.  
Thompson  
Marian A. Clark  
Dorothea Griesbach  
Kathleen Tappen  
Elizabeth V. Wolf

Maxine Wiley  
Donald Forsyth  
Frances Conrad  
Graham Parker  
Singer  
Jeanette Plaut  
Agnes Hubbard  
Robert Rosenthal  
Jane Thayer  
Jean Moir  
Anita R. Cardoza  
Esther Walcott  
George S. Read  
Lois Taylor  
Anne L. New  
Peggy O'Callaghan  
Helen Louise  
Whitehouse  
Kathryn Eshleman  
Sam Herman  
Louise G. Isfort  
Ruth Hard

### DRAWINGS

Margaret B. Scott  
Margaret Haley  
Mary Daniel  
Moore  
Marion C. Smith  
Rosamond Lane  
Marjorie Nahl  
Elizabeth Wells  
Norman Hallock  
Elizabeth Ingorsoll  
George C. Wiggins  
Paul Kelly  
Wanda  
Petrunkevitch  
Myra Alice Sobel  
Betty Muir  
Elizabeth Flinn

### PHOTOGRAPHS

Albert H.  
Halberstadt  
Jack S. Booth  
Susan Hammond  
Violet A. Rankin  
Kate W. Nelson  
Marjorie Serrat  
Edith Reeve  
Frederick H.  
Gillmore  
Mabel Spoon  
Helen E. Taber  
Helen Loeffler

Lillian Gallion  
Rice S. Estes  
Lena C. Riley  
Alice Winston  
Elita Downey  
Wallace G. Teare  
Elizabeth D'Arcy  
Edna Bennett  
Margaret Evenson  
Isabel P. Brooks  
Sarah Miller  
Emily Randall



"AT WORK." BY  
BARBARA BRADLEY,  
AGE 12

### PUZZLES

George E.  
Utterback  
Rosina Shepardon  
Rosalind Howe  
Rubin Widess  
Sarah M. Parks  
Louise Einlaw  
Kenneth W. Dow  
Ah Quan Young  
Margaret C.  
Fassitt  
Ruth Rich  
Sarah H. Butcher  
Elizabeth Bentley  
Helen Ferguson  
Rose Dubriltze  
Muriel Hoehdorf  
Donald Johnson

## WHAT THE LEAGUE IS

THE ST. NICHOLAS LEAGUE is an organization of the readers of the ST. NICHOLAS MAGAZINE.

THE LEAGUE motto is "Live to learn and learn to live."

THE LEAGUE emblem is the "Stars and Stripes"

THE LEAGUE membership button bears the LEAGUE name and emblem.

THE ST. NICHOLAS LEAGUE organized in November, 1899, became immediately popular with earnest and enlightened young folks, and now is widely recognized as one of the great artistic educational factors in the life of American boys and girls.

THE ST. NICHOLAS LEAGUE awards gold and silver badges each month for the best *original* poems, stories, drawings, photographs, puzzles, and puzzle answers.

## PRIZE COMPETITION, No. 275

**Competition No. 275** will close November 1. All contributions intended for it must be mailed on or before that date. Prize announcements will be made and the selected contributions published in ST. NICHOLAS for February. Badges sent one month later.

**Verse.** To contain not more than twenty-four lines. Subject, "Beside the Fire."

**Prose.** Essay or story of not more than three hundred words. Subject, "A Nature Story."

**Photograph.** Any size, mounted or unmounted; no blue prints or negatives. Young photographers need not develop and print their pictures themselves. Subject, "An Attractive Subject."

**Drawing.** India ink, very black writing-ink, or wash. Subject, "At the Door," or "A Heading for February."

**Puzzle.** Must be accompanied by answer in full.

**Puzzle Answers.** Best and neatest complete set of answers to puzzles in this issue of ST. NICHOLAS. Must be addressed to THE RIDDLE-BOX.

No unused contribution can be returned *unless it is accompanied by a self-addressed and stamped envelop of proper size to hold the manuscript or picture.*

## RULES

ANY reader of ST. NICHOLAS, whether a subscriber or not, is entitled to League membership, and upon application a League badge and leaflet will be sent free. No League member who has reached the age of eighteen years may compete.

Every contribution, of whatever kind, **must bear the name, age, and address of the sender and be indorsed as "original" by parent, teacher, or guardian, who must be convinced beyond doubt—and must state in writing—that the contribution is not copied, but wholly the work and idea of the sender.**

If prose, the number of words should also be added. These notes must not be on a separate sheet, but *on the contribution itself*—if manuscript, on the upper margin; if a picture, *on the margin or back*. Write in ink on one side of the paper only. A contributor may send but one contribution a month—not one of each kind, but one only; this, however, does not include "competitions" in the advertising pages or "Answers to Puzzles."

Address: **The St. Nicholas League,**  
The Century Co.

353 Fourth Avenue, New York.



"AT WORK." BY JEAN MCCRUM, AGE 16



## THE LETTER-BOX

CLEMSON COLLEGE, S. C.

DEAR ST. NICHOLAS: I am so happy, I feel like dancing. I won you for a whole year as a prize in our music club. My teacher said she knew that I would rather have you than most anything else. She knows how much I love you and how I have been reading a friend's copy of you every month. That is not like owning you myself, and I think that explains why I am so happy. When I was told that you were the prize, I could not keep from jumping up and down.

Clemson College is the agricultural and mechanical college of South Carolina. My father teaches electrical engineering here, and we live on the college campus. We seldom have snow here, but we are so near the Blue Ridge Mountains that we often feel the cold winter winds.

A new and happy subscriber,  
ELIZABETH DARGAN (AGE 13).

KANSAS CITY, MO.

DEAR ST. NICHOLAS: I am not a subscriber, but I am a constant buyer of you. My friends, older and younger, say, "Oh, you're too old for ST. NICHOLAS MAGAZINE. Why, I took it when I was nine years old!" But nevertheless, they always pick it up when they are over at my house and read many of the stories and scan every page, it seems to me. I enjoy it immensely, although I am "too old."

I'm crazy about your stories, especially Augusta Seaman's mystery stories, and could hardly wait from month to month for the next number to come, so that I could go on with the thrilling "Mystery at Number Six."

I am surprised at the number of foreign readers you have, from Italy, Peru, and Mindanao. Mother said she always loved you when she was a little girl, and I'm going to tell my children the same thing.

Your reader always,  
MILDRED MUDGE (AGE 14).

SOUTH NORWALK, CONN.

DEAR ST. NICHOLAS: I see in THE LETTER-BOX so many praises sung to your honor that I doubt if very much could be added. However, I must say that, in my estimation, you are the best magazine on the market. I have received you for three years now as a Christmas present from a friend of mine. Last year she inquired of me whether I would not rather have something else for a present, but I replied "No," in as emphatic a manner as possible.

I live in a very pretty town here. It has always been my desire to live in New England, and I have now, for a year. It seems to me that there is some charm to New England that I have never found in any of the other States I have visited. On the edge of the town there are some woods and I love to spend the day in them picking the wild flowers. Such beautiful swamp-violets are found there!

I am most interested in "The Turner Twins" and "The Blue Envelop." I read a great many stories and novels, but it is so nice to read about boys and girls of my own age. Reading those comical rhymes about the king and his court, I

laugh until my sides ache. I love the ST. NICHOLAS LEAGUE pages!

One reason I like school vacation is because it gives me more time to pore over your dear pages.

Your enthusiastic reader,  
CONSTANCE LEWIS (AGE 14).

TEDDINGTON, MIDDLESEX, ENGLAND.

DEAR EDITOR OF ST. NICHOLAS: I have just recently taken up your magazine again, after not having had it for about a year, and I think it is much better than any other magazine I know.

My brother and I wait very anxiously every month for ST. NICHOLAS, and when it arrives there is a great scramble to see who shall read it first.

I like "The Mystery at Number Six," and also THE WATCH TOWER, which is very instructive.

All the back numbers are saved, because it is very nice to read them again during the long winter evenings. I think all readers will agree with me that every number is better than the last.

Yours faithfully,  
JOHN WALTON (AGE 11).

ORLEANS, MASS.

DEAR ST. NICHOLAS: We have taken you for six years and love you more and more. We are triplets, aged fifteen. We certainly do have good times together. At school we have great fun with new teachers, because they can never tell us apart.

We have just come home from Egypt, where we have been followed by you, dear ST. NICHOLAS. While there we rode on camels and were nearly jounced to death.

We remain, your loving readers,  
MARTHA, PEGGY, and HELEN HUNTLY.

PALIZADA, MEXICO.

DEAR ST. NICHOLAS: I enjoy you very much. I live one hundred and fifty miles southwest of Mexico City, in the mountains, and have spent five years in Chihuahua, and over one year here in Mexico State. There are many Indians here. They can carry heavy loads for fifty and a hundred miles. It is never warm here, and at the foot of the mountains it is never cold.

Your faithful reader,  
JOHN D. FULLER (AGE 10).

PORTERVILLE, CALIF.

DEAR ST. NICHOLAS: I certainly think you are the best magazine there is, and every one I know who takes you does, too.

I have just read "Splash," by George H. Corson, and was very much interested in it, as we have a swimming-pool of our own. It is 45 feet long and 15 feet wide. It deepens gradually from 3½ feet deep to 6 feet deep.

Neither my older sister nor myself knew a thing about the water when it was built, three years ago last July. Now we can both swim, dive, somersault, dive for pennies, swim under water, and do many other such things. I love the water.

My two-and-a-half-year-old sister can almost swim and is perfectly at home in the water.

Your ever interested reader,  
MIRIAM MILLER (AGE 11).

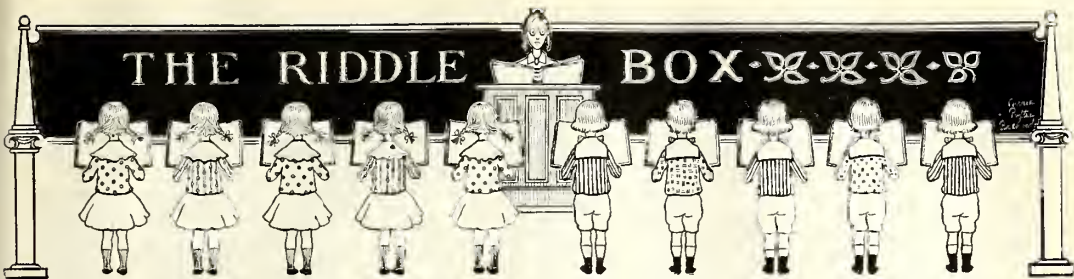

ANSWERS TO PUZZLES IN THE SEPTEMBER NUMBER

CHARADE. Cant-cloze.  
 DIAGONAL. Scambr. Cross-words: 1. Scythic. 2. Legend.  
 3. Orange. 4. Clairor. 5. Samba. 6. Seaman.  
 CROSS-WORD ENIGMA. Labor Day.  
 NUMERICAL ENIGMA. "To know the glory of life, you must help others."  
 ANCHOR PUZZLE. Centrals, "The Ancient Mariner." Cross-words: 1. Sty. 2. The. 3. Expense. 4. Equator. 5. Evangel. 6. Act. 7. Sir. 8. Met. 9. Ant. 10. Ate. 11. Imp. 12. Mar. re-mar-k's. 13. Transcription. 14. Exhibitions. 15. Reconcile. 16. Lct. 17. R.  
 PICTURED ANSWERS. 6. Watch. 3. Horse's bit. 1. Drum. 8. Cork.  
 DOUBLE ACROSTIC. Primals, Anne Boleyn; finals, Henry Tudor. Cross-words: 1. Arch. 2. Nice. 3. Noon. 4. Ever.

5. Body. 6. Oust. 7. Lieu. 8. Eked. 9. Yezo. 10. Near.  
 DIAMONDS CONNECTED BY A SQUARE. 1. M. 2. Ban. 3. Magie. 4. Nip. 5. C. H. 1. C. 2. Eli. 3. Clove. 4. Ivy. 5. E. III. 1. Chase. 2. Haven. 3. Avart. 4. Serve. 5. Enter. IV. 1. E. 2. Fig. 3. Eider. 4. Gem. 5. R. V. 1. R. 2. Met. 3. Revel. 4. Ten. 5. R.  
 ARITHMETICAL PUZZLE. David was 16, his grandfather, 64.  
 A MILITARY ACROSTIC. Initials, The Revolutionary War. From 1 to 16, George Washington; 17 to 26, Paul Revre; 27 to 36, Bunker Hill; 37 to 47, Valley Forge; 48 to 55, Redcoats. Cross-words: 1. Thicker. 2. Hollows. 3. Evident. 4. Revolve. 5. English. 6. Vehicle. 7. Observe. 8. Languid. 9. Utility. 10. Typical. 11. Imagine. 12. Offered. 13. Neglect. 14. Audible. 15. Ringing. 16. Younger. 17. Warrior. 18. Augment. 19. Rampart.

TO OUR PUZZLERS: To be acknowledged in the magazine, answers must be mailed not later than October 27 and should be addressed to ST. NICHOLAS RIDDLE-BOX, care of THE CENTURY CO., 353 Fourth Avenue, New York City, N. Y. Solvers wishing to compete for prizes must comply with the LEAGUE rules (see page 1341) and give answers in full, following the plan of those printed above.

ANSWERS TO ALL THE PUZZLES IN THE JULY NUMBER were duly received from Cornelia M. Metz—Frances Winfield—Gertrude R. Jasper—Elsa Talney—Gertrude Wagner—Glady's Phillips—Vera A. Skillman—Ruth Tangier Smith—William Pratt—Helen Melver—Helen A. Moulton—"Sun and Moon"—L. and K. Jones—"Allil and Adi"—John F. Davis—"The Three R's"—E. Holmes and C. Hazelton—Kemper Hall Chapter.

ANSWERS TO PUZZLES IN THE JULY NUMBER were duly received from Marion Nottage, 9—Chestine Knight, 9—"Little Boar's Head," 9—John S. Davenport, 9—Helen O'Carra, 9—Hortense A. Doyle, 9—Virginia Appar, 8—M. and M. Swift, 8—Allan D. Langerfeld, 8—Elizabeth Bentley, 7—Helen Sumner, 7—"Blackie," 7—Pauline Paxton, 7—Gordon R. Silber, 6—Charles Wood, 6—Helen Toren, 6—Enil Dessonneck, 5—Faith Warburton, 5—Wilfred Williams, 5—Helen L. Duncan, 5—Elizabeth Taylor, 5—M. T. Sledge, 4—Louise Thompson, 4—M. E. Outerbridge, 4—Frances L. Flagg, 4—Gertrude M. Seymour, 4—Jane A. Beattie, 4—Margaret Halsey, 4—Kingsley Kahler, 4—Winifred V. Root, 4—Margaret C. Jeffords, 4—Dorothy VanDeman, 4—Margherita Burnside, 4—Rachel P. Lane, 4—Doris Lieberman, 4—Carlan S. Messler, 4—D. Mills, 3—H. A. Böhme, 3—M. Wilson, 3—C. Mitchell, 3—G. C. Cameron, 3—I. Henry, 3—M. Rothschild, 3. Two puzzles, M. O'K.—R. C. A.—J. R.—N. P.—R. and H. B.—C. F. G.—H. S. S.—B. T.—S. B.—E. T.—H. M. B.—M. C. T.—L. P.—M. S.—H. F.—A. O.—C. W. MacD.—F. L.—J. L. L.—B. P.—G. B. K.—E. P.—A. H. P. Owing to lack of space, the initials of those who sent one answer can not be printed.

CROSS-WORD ENIGMA

My first is in March, but not in November;  
 My second, in November, but not in July;  
 My third is in July, but not in January;  
 My fourth is in January, but not in May;  
 My fifth is in May, but not in February;  
 My sixth is in February, but not in June;  
 My seventh is in June, but not in September;  
 My eighth is in September, but not in March,  
 My whole was an illustrious man.

certain musical instrument of four strings. 6. An Indian name for a woman. 7. To pursue for the purpose of killing or capturing. 8. To form by heating and hammering. 9. A retinue.  
 EMMA LOUISE MIESCHER (age 10), *League Member*.

FRANCES EMERSON (age 12), *League Member*.

ANAGRAM WORD-SQUARE

Rearrange the letters in the following words so as to make four new words which will form a word-square:

VENT, RASP, VANE, PEAR

K. D. MITCHELL (age 15), *League Member*.

FINAL ACROSTIC

All the words described contain the same number of letters. When rightly guessed and written one below another, the final letters will spell a familiar word.

CROSS-WORDS: 1. A flambeau. 2. An Asiatic country. 3. To sing in tremulous vibrations. 4. A month. 5. A common abbreviation for a

A TOWER PUZZLE

(Silver Badge, St. NICHOLAS LEAGUE Competition)

25	*	23	
10	*	16	
.	*	.	
.	*	5	
14	*	9	
4	*	.	
8	*	7	
.	*	.	
.	*	.	
3	*	27	22
1	.	*	6
18	17	.	2
11	12	13	24
15	20	19	.

CROSS-WORDS: 1. In tower. 2. Edge. 3. Away. 4. A newt. 5. A jewel. 6. A tree. 7. Consumed. 8. Turf. 9. To be indebted to. 10. The top of a wave. 11. A fine city. 12. A day of the week (six letters). 13. A small, shrill cry (six letters). 14. A fruit (six letters).  
 When these words have been rightly guessed, the central letters (indicated by stars) will name a famous structure. The letters indicated by the figures from 1 to 8, from 9 to 20, and from 21 to 27 name three other famous structures.

MIRIAM MORSE (age 13).



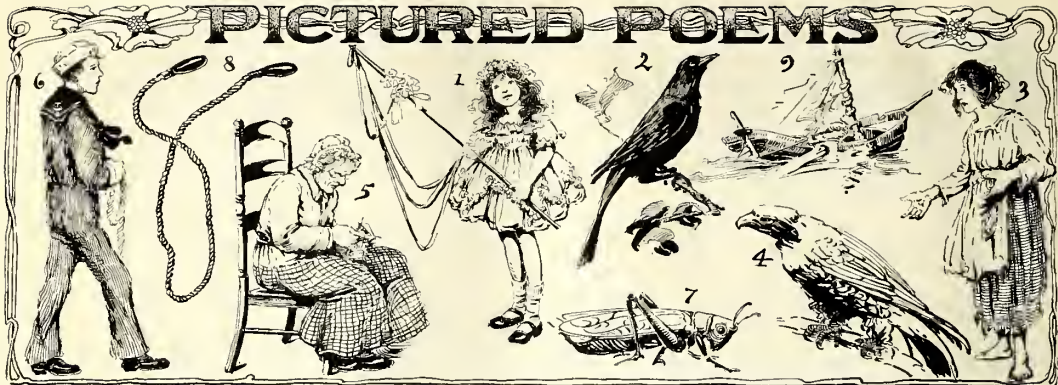

In the above illustration the names of nine poems are pictured. All the poems are by the same writer. What are the poems and who is their author?

### CHARADE

From out my *first* is water drawn,  
 (Some small red farm-house near).  
 My *second* are our relatives,  
 That to us all are dear.  
 My *whole*, a vegetable of size  
 Which children, far and near,  
 Have fun with on a certain day  
 That comes in every year.

ELINOR GOODWIN WELCH (*League Member*).

### SINGLE ACROSTIC

(*Silver Badge*, St. NICHOLAS LEAGUE Competition)

All the words described contain the same number of letters. When rightly guessed and written one below the other, one of the rows of letters will spell the name of a character famous in history.

CROSS-WORDS: 1. A state of profound insensibility. 2. A metal. 3. Obscure. 4. A kind of fuel. 5. A college officer. 6. A company of musicians. 7. To detest. 8. A bird, usually black. 9. A narrow way. 10. Playthings.

KATHERINE G. TODD (age 13).

### PI

Cotbore bigrns het sthevar  
 Twih palspe, durdy nad wronb,  
 Nad terse ni teh lepap cordhar  
 Hwit turif rea endbing wond.

REGINA C. KRUEGER (age 11), *League Member*.

### ADDITIONS

(*Gold Badge*, St. NICHOLAS LEAGUE Competition)

EXAMPLE: Add a number to an emmet, and make a dweller. ANSWER: ten-ant.

1. Add a sailor to a color, and make a Scottish fabric.

2. Add a covering for the head to a color, and make repugnance.

3. Add a termination to the organ of hearing, and make to become precious.

4. Add away to completion, and make to displease.

5. Add a speck to an era, and make feebleness of mind in old age.

6. Add away to suitable, and make equipment.

7. Add a rodent to a color, and leave a long, flexible stem.

8. Add the organ of hearing to a covering for the head, and make an insect.

9. Add to decay to a number, and make corrupt.

10. Add exterior to a shriek, and make clamor.

11. Add distant to a cold substance, and make a place for transacting business.

12. Add a near relative to a snare, and make a short poem.

13. Add to mistake to a common word, and make a commission.

14. Add an abbreviation of viscount to an epoch, and leave a face.

15. Add to mistake to an emmet, and make roving.

16. Add a limb to a termination, and leave a fable.

17. Add a small point to a beloved object, and leave a covering for the neck.

When these additions have been rightly made, the initials of the six-letter words will spell the name of a great American born in October.

WALTER GUTMANN (age 13).

### GROWING WORDS

EXAMPLE: 1. A letter. 2. Near. 3. Fit. 4. Portion. 5. To babble. ANSWER: t, at, apt, part, prate.

I. 1. A letter. 2. A near relative. 3. To copy. 4. A fruit. 5. A gem.

II. 1. A letter. 2. A verb. 3. An ornamental border to a picture. 4. Domesticated. 5. Intended.

III. 1. A letter. 2. An adverb. 3. Rested. 4. A place to rest. 5. To annoy.

RHODA TELFORD (age 11), *League Member*.

### NOVEL DOUBLE ACROSTIC

(*Silver Badge*, St. NICHOLAS LEAGUE Competition)

All the words described contain the same number of letters. When rightly guessed and written one below another, the initials will spell the name of a book known to young folk, and another row of letters will spell the name of the author.

CROSS-WORDS: 1. A popular language. 2. To sanction. 3. Real. 4. A large, edible fish. 5. Very thin fabrics. 6. A species of leopard tamed and used for hunting in India. 7. An eight-sided figure. 8. To turn to profitable account. 9. A fainting fit. 10. To implicate. 11. A remote planet. 12. Cunning or crafty.

ALICE KERR (age 14).



## Pictures of your pets with a **BROWNIE**

With this simply-operated, Eastman-made camera, it's good fun and good pictures from the start.

*Brownies (Box Type) \$2.00 up*

*Autographic Brownies up to \$17.00*

Eastman Kodak Company, Rochester, N.Y. *The Kodak City*



They are not Keds unless  
the name Keds is on the shoe



Sturdy sport shoes  
—with or without  
heels. Made of heavy  
white or brown duck,  
and stoutly reinforced

## Tough and Rugged— yet light and cool

The scraping and twisting on rough trails—the constant friction and strain on hard tennis courts.

Keds are made for just such wear. These are the shoes that stand up under the hardest tests of summer days.

There are Keds suitable for every purpose, indoors and outdoors, for sport and street wear. Behind every pair is all the skill and experience of the oldest and largest rubber organization in the world.

Keds wear longer not only because of the special rubber compound in their tough, springy soles, but because they are *strong all over*. Uppers of finest white or colored canvas, closely woven, yet cool and pliable. Made extra strong at every point of strain.

But remember, Keds are made only by the United States Rubber Company. If the name Keds isn't on the shoes they aren't real Keds.

Ask your dealer to show you Keds today. If he hasn't just the kind you want, he will get them for you.

Booklet, "Basketball," sent free if you write Dept. D-7, 1790 Broadway, New York.

United States Rubber Company



# Keds

Trademark Reg. U. S. Pat. Off.

# MARVELOUS MOVIES

for the HOME, SCHOOL, CHURCH

CLUB  
CAMP  
OFFICE



The  
"Paramount"  
Motion Picture Machine

(Patents pending)

complete, weighs only twelve (12) pounds.

Professional Construction Absolutely Safe

Our Film Service is Available  
Includes the Best Movie Stars

Price - \$35.00

(Sent anywhere—ready for use)

Inquire at your nearest dealer. If he cannot supply you write us mentioning dealer's name and we will send you our free catalogue. Remember there is no substitute for the PARAMOUNT.

PARAMOUNT MFG. CO.

Box 1371, Dept. 54-C, Boston, Mass., U.S.A.



## Gifts Galore for Kiddies and for Grownups, Too!

UNUSUAL gifts by the hundred are pictured and described in the 1923 Kellogg Gift Book. Every page offers timely, helpful suggestions. There's something just right—at the right price—for everyone you want to remember. Gift surprises aplenty await you in this interesting Gift Book.

### Descriptions of Items Shown Above:

B725 "Good Luck" jointed Missouri Mule.....	\$1.75
B320 Bridge Table Numbers. Per set.....	.75
Keytainer No. 355 (for 6 to 8 keys).....	.85
"    No. 356 (for 10 to 12 keys).....	\$1.10
"    No. 389 (for 14 to 16 keys).....	\$1.50
B145 Zephyr Play Ball.....	! .60

Send for Your FREE Gift Book NOW!

ROBERT W. KELLOGG

182 Bridge Street

Springfield, Mass.

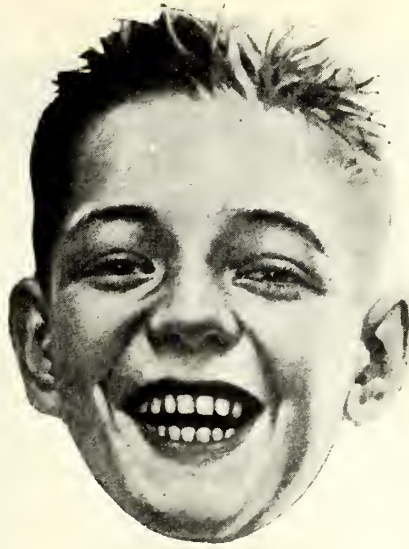

# Ives Trains

**A**N IVES Railroad System will make any boy smile. The Ives Railroad outfits suit any purse, too. They range from \$1.75 to \$50.00 in price. There are spring locomotives that whiz around an "O" gauge track and monster electrics, that operate on standard 2-gauge track which are exact copies of the latest New York Central models. The Ives Railroad Systems have a dazzling variety of bridges, tunnels, switches, passenger and freight stations, signals and railroad equipment lights. The cars like the locomotives are also exact copies. The freight cars are painted like the real ones on principal railroads—coal cars, tank cars, flat cars, lumber cars, cabooses.

Our beautiful 1922 catalog ablaze with color will tell

you all about these wonderful trains as well as the Ives Boats. Remember that the Ives Trains can be operated either indoors or out. After the indoor season their substantial construction makes them an ideal outdoor toy. You boys can build a railroad, running a spur track to the edge of a pond or brook, ship the freight to a miniature wharf and load it on an Ives merchant ship—an entire transportation scheme all with Ives equipment. No other manufacturer furnishes this complete outfit. It can all be bought in separate units.

Send 10c right now for our dandy 1922 catalog in colors, showing Ives Trains and Boats.

THE IVES MANUFACTURING CORPORATION  
219 Holland Avenue Bridgeport, Conn.

# Ives Toys

## MAKE HAPPY BOYS

### *Special \$15. Combination*

The Ives Electric Train Outfit 31 inches long, consisting of reversible locomotive with electric headlight, 3 cars with automatic couplers. 14 feet of track, station, tunnel, semaphore, danger signal and 6 telegraph poles. If your dealer cannot supply you send us the money and we will see that you are taken care of.

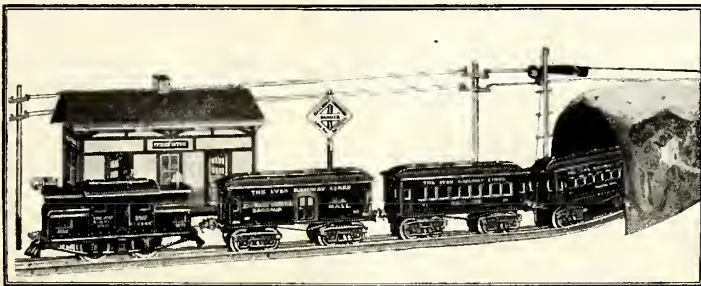





*A. G. Spalding & Bros.*

# Basket Ball

Spalding Quality is conceded superior by those who have had experience, and the boy who is taking up basket ball—or any athletic sport—should start right. His enjoyment, his best efforts, will be multiplied when he uses Spalding equipment. Always look for the Spalding Trade-Mark. It is your guarantee of the best.

The Spalding Official No. M Basket Ball is the official ball of the game since its origin. Balls—Uniforms—Jerseys—Pants—Shoes—everything for the player.

Catalogue of Basket Ball and all Fall and Winter sports equipment mailed free on request.

*Spalding's Official Basket Ball Guide—25 cents*

**A. G. SPALDING & BROS.**

New York

Chicago

San Francisco

STORES IN ALL LARGE CITIES

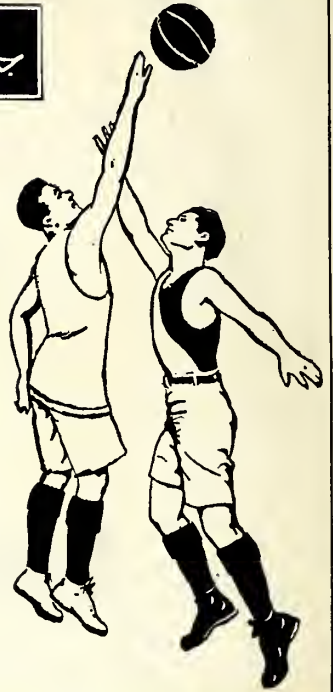

## PROFITABLE HOME WORK

Any Girl or Boy can earn a steady income in spare time coloring Christmas and Birthday Greeting Cards, Pictures, Mottoes, etc. It's fascinating and pleasant. Easily sold to friends, relatives and dealers. Our catalog contains 148 designs specially made for hand coloring. Sent free upon request.

FISHEL, ADLER & SCHWARTZ CO., Dept. 4  
338-340-342 East 59th St., N. Y.

**10 Buys** **Engel**  
**100** **"Art Corners"**  
Millions in use to-day

**Use them to mount all kodak pictures, post cards, clippings in albums**

**NO PASTE NEEDED**  
Made in Square, Round, Oval, Fancy and Heart of black, gray, sepia, and red gummed paper. Slip them on corners of pictures, then wet and stick.

**QUICK-EASY-ARTISTIC.** No mess, no fuss. At photo supply, drug and stat'y stores. Accept no substitutes; there is nothing as good. 10c brings full pkg. and samples from Engel Mfg. Co. Dept. 115-K 4713 N. Clark St., Chicago

## Ride A Ranger

The finest bicycle ever built. 44 Styles, colors, sizes; made in our new factory. SAVE \$10 to \$25 by direct from the factory purchase.

Delivered free on approval, express prepaid, for 30 Days' Free Trial. 12 MONTHS to PAY, if desired. Tires best quality at factory prices, express paid. Lamps, wheels, horns, equipment and repairs at unusually low prices. Send No Money, do business direct with makers.

**Mead Cycle Company**  
Dept. B15 Chicago

Write today for free Ranger Catalog, factory prices and marvelous easy payment terms



## CLASS PINS

FREE CATALOG GIVE NAME OF SCHOOL OR CLUB AND NUMBER IN CLASS

Either pin illustrated made with any 3 letters and 2 figures, one or two colors enamel. Silver plate, 20¢ ea., \$2.00 doz. Sterling silver, 40¢ ea., \$4.00 doz. Write for catalog of sterling and solid gold pins and rings.



Bastian Bros. Co. 447 Bastian Bldg., Rochester, N.Y.

**I**F you are looking for a school for your boy or girl turn back to the School Advertising Section in the front of the magazine. The schools advertised there are among the very finest in the land.

They are located in different parts of the country, and differ in kind of facilities, equipment, amount of tuition, etc. Drop us a line and we shall be glad to furnish you with further information.

SCHOOL SERVICE DEPARTMENT

ST. NICHOLAS MAGAZINE

353 FOURTH AVENUE NEW YORK CITY

# Quick to relieve the pain of burns!



In the kitchen during the absence of help, or to prepare a special dish, you are quite apt to forget hot handles and the imprisoned steam under a cover or behind an oven door.

In such emergencies Absorbine, Jr. affords prompt relief. It is an anti-phlogistic and stops inflammation and soreness. It is cooling, soothing and healing.

Absorbine, Jr. prevents infection

from cuts, scratches and bruises. After sudden or long continued exercise, its application prevents next-day lameness, stiffness and soreness.

In one convenient container you have both an antiseptic and a germicidal liniment. It is safe, of a clean, pleasant odor and without the usual liniment stain; especially desirable characteristics where there are children about.

At most druggist's, \$1.25, or postpaid. Liberal trial bottle, 10c., postpaid.

W. F. YOUNG, Inc., 360 Temple St., Springfield, Mass.

**Absorbine, Jr.**  
THE ANTISEPTIC LINIMENT

## WINTERGREEN

By JANET LAING

AN absorbing, jolly and refreshing love-story set in a little Scotch village on the rocky seashore, old and clean and individual. It is as amusing and human and thoroughly delightful as "When Bunty Pulls the Strings."

Price \$1.75

## SEA WRACK

By VERE HUTCHINSON

A POWERFUL love-story in which are combined keen characterization, rich personality, fine and poignantly-felt writing, and a setting strangely alive and memorable. Already a marked success in London, where the reviewers compare it with "Wuthering Heights."

Price \$1.75

The Century Co. 353 Fourth Avenue  
New York City

## Wolverine Sport

### A Real All Steel Coaster

Wolverine wagons are built for real service. Made like an automobile of all pressed steel parts securely braced and built to withstand years of hard usage. Just the wagon for the live boy. Roller bearings. Rubber-tired disk wheels. If your local dealer does not handle will ship direct. Made in three sizes. Sport size below, body 12 x 28, inside measurements.

\$8.50 East of Mississippi

\$9.50 West-Express Prepaid

*It's All  
Steel*

DAIL STEEL PRODUCTS  
COMPANY

2320 Main Street

Lansing, Michigan







*The New, 1922 OZ Book*  
**Kabumpo in OZ**

There are now 15 of the Famous Stories of the Fairyland of OZ. Kabumpo is an Elegant Elephant, and the account of his marvelous adventures makes the merriest and most amusing OZ Book to date.

*100 Wonderful Pictures 12 Full color pages*



**The Teenie Weenie Books**

By WM. DONAHEY

Different from all other books for children. All about the "Littlest People." Fascinating, interesting, unique.

*Delightfully funny pictures  
 8 Full pages in 4 colors*

Adventures of the Teenie Weenies  
 The Teenie Weenies Down the River  
 The Teenie Weenies Under the Rose Bush

AT ALL BOOKSTORES

The Famous OZ Books \$1.75 per volume  
 The Teenie Weenie Books \$1.75 per volume

Publishers — REILLY & LEE — Chicago

**BOYS, YOU CAN MAKE BIG MONEY**

selling THE BOYS' MAGAZINE each month. Write us today for 5 copies. *Send no money.* Address

THE SCOTT F. REDFIELD CO., Inc.

7270 Main St. Smethport, Pa.

**BOYS AND GIRLS!**

ARE you interested in saving stamps? It is really a fascinating pastime, and one that will give a lot of valuable information.

If you want to get started write one of the stamp dealers advertising a few pages further on, and he will be glad to send you some stamps, catalogue, etc.

**OORANG  
 AIREDALES**

*The 20th Century  
 All-Round Dogs*



**CHOICE PUPPY STOCK FOR SALE**  
*Twelve Famous Oorangs at Stud*

*Also*

**Oorang Dog Remedies**

**Oorang Dog Biscuits**

**Oorang Dog Supplies**

*Write for Catalog*

**OORANG KENNELS**

World's Greatest Airedale Breeders  
 Dept. 16 LA RUE, OHIO

**Moore Push-Pins**  
*Glass Heads - Steel Points*  
**Moore Push-less Hangers**  
 To hang up things  
*Ask your dealer to show them*  
 Sold Everywhere **10¢** per packet  
 Moore Push-Pin Co.  
 Wayne Junction Philadelphia

**The Importance of Bird Life**

By GEORGE INNESS HARTLEY

A POPULAR account of the economic significance and conservation of bird life. It will prove to most readers an astonishing revelation of the importance of bird life to human life. The book covers the subject fully in all its interesting ramifications and in many novel aspects. There are chapters on domesticated fowl; on pigeons; on the training of wild birds; on birds as food; on feathers and the feather industries; on birds and game; and the history of their protection and conservation.

*Illustrated. Price \$2.00*

**The Century Co.** 353 4th Ave. New York City

## He's a Happy Kid

When his folks gave him a genuine Patrick sweater he knew he had a REAL sweater just like his dad and Uncle Bob wear when they go hunting.

Such a sweater pleases any honest-to-goodness boy. It wears and wears, because of the highest grade, pure virgin wool used, "from sheep that thrive in the snow." Write for new catalog telling all about Patrick pure wool products.

Sold at best dealers everywhere.

"Bigger Than Weather"

F. A. PATRICK & CO. Duluth, Minnesota



## Pure Northern Wool



from  
sheep that thrive in the snow

## To Place An Advertisement in ST. NICHOLAS

means that you are bringing the name of your product to the attention of thousands of children and their families all over the United States. These children come from the best homes in the land, and will soon become influential citizens in their communities.

To impress on their young minds the qualities of your merchandise is a big step towards molding the opinion of future customers, as well as a wedge into a tightly closed pocketbook to-day.

A page in the advertising section of ST. NICHOLAS is an excellent investment, and one that pays a high rate of interest.

For further particulars, address

**ST. NICHOLAS MAGAZINE**

353 FOURTH AVENUE

NEW YORK CITY

## DIVER DAN



Is a Tub Time Joy



Children love this brave little fellow as a playmate in the bath tub. He's a merry-looking boy. Perhaps it's because he is well filled and fattened with cork. He goes through the water like a fish and little folks like to stay in the tub with him. Dan is sent anywhere, postpaid, for \$1.50. Ask for No. 1755.

## CHILD'S DESK SET and Writing Paper

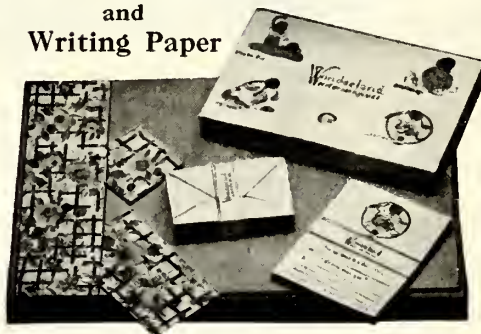

Any little boy or girl will love to own this set. Covered with gay crenonne. Set consists of desk pad, blotter, pen wiper and box of note paper and envelopes illustrated in color with designs of Ding Dong Bell, Little Miss Muffett, Curly Locks, and Jack, Be Nimble. Set complete for \$1.50, postpaid. Ask for No. 4421. Send for the Pohlsion Year Book showing scores of gifts for old and young.

POHLSION GIFT SHOP, PAWTUCKET, R. I.

## CLASS RINGS & PINS

Beautiful Catalogue sent free on request. We send samples on approval. Pin as shown, Silver Plate, 2 colors of Enamel, 3 letters and date, 25c each; 12 or more, 20c each. Sterling Silver, 45c each; 12 or more 40c each. Add 5% war tax.



METAL ARTS CO., Inc.  
7751 South Ave.

No. 686  
Rochester, N. Y.

## OUR MEDICINE MEN

By K\_\_\_\_\_, M.D.

A BRILLIANT exposé of the pompous pretensions and dangerous mistakes of the medical profession, by an eminent member who has made a special study of its actual practices, written in a style as sharply clear as the statements are shockingly surprising. The author knows his subject so well that he can be at once brief and entirely accurate. A thunder-and-lightning book which should clear the atmosphere.

Illustrated. Price \$2.00

The Century Co. 353 4th Ave.  
New York City



# ST. NICHOLAS STAMP PAGE

CONDUCTED BY SAMUEL R. SIMMONS



## NEW ISSUES

THERE have come upon the market recently very many new issues. Not only the new water-mark upon British Colonies and the new values appearing in the old designs, but also a number of new designs, some of which will be sure to interest every collector. We have selected a few of the most interesting ones to illustrate for the benefit of our readers. First of all, we show a stamp from a new country—"Barbuda." This somehow suggests Barbadoes and Bermuda. For many years, some of the most popular series of stamps, especially perhaps with older collectors, have been those issued by the West Indian group of islands. Not long ago this group was increased in number by stamps from the Cayman Islands. Then came a series of stamps from the "Turks and Caicos Islands." And now Barbuda makes its bow to stamp-collectors and presents its first stamp. The stamps of this island bear a surcharge in heavy black letters upon the Leeward Island issue. Naturally, therefore, when we look for Barbuda in our geographies we find it located among the Leeward Islands, not far from Antigua—an old friend to all stamp-collectors. Barbuda is a very small island and has hitherto supplied the postal needs of its few inhabitants with the stamps of either Antigua or Leeward Islands, which have been used more or less indiscriminately. Undoubtedly, this new set is more for financial necessities than postal. But for the sake of its association with the other fascinating stamps from the British West Indies, we welcome this latest arrival in the family, despite the increased drain upon the purse of the long-suffering philatelist. For many years to come Belgium will be very close to the hearts of us all. Whatever she does will demand our interest and attention. We show this month two stamps from that country. The first is for ordinary postal use. This

is the 25-centime, with a new portrait of King Albert. It is purple in color and not particularly attractive, as the workmanship is not fine, looking more like a lithographed than an engraved stamp. But the second new stamp from Belgium surely is a gem in philatelic eyes. One cannot help but note with patriotic pride that the exquisite engraving is the product of one of our own bank-note companies. The color is a soft brown or sepia. At the top is a portrait of King Albert in a small circular frame, while before the picture kneels a nude figure with bandaged head, looking upward at the king. In the right hand of this figure is a broken staff; in its left, a sword and a palm-leaf for victory. Above at the right is the word "Belgique"; and at the bottom and left is "Belgie." Before the figure is a tablet with the words "Pour les Invalides"—"Voor de Invaliden" and the figures of value—20 c.+20 c. (the stamp to be sold for double face-value). The whole is an exceedingly striking production. Czecho Slovakia sends us a new airplane stamp. It is a surcharged stamp—50 heller upon the ordinary 100 heller, green, of the type of Scott's Catalogue No. 156. The airplane surcharge is much like that used for catalogue No. 504, but with this interesting difference—the old value is obliterated with what at first appears to be two parallel bars, but a closer look shows them to be two airplane paddles. From Finland comes a Red Cross stamp in which every one will be interested, for the size, shape, coloring and design all combine to make it very attractive. First, the central oval and the word Suomi above it and Finland below it are in a soft, beautiful gray. Then on this gray background is printed the central cross in bright red. And then over these two, falling partly on the red and partly on the gray, printed in white, is the well-known Finnish lion, while at the bottom is the value in red 1 M + 50 P.

(Concluded on second page following)

## THE ST. NICHOLAS STAMP DIRECTORY

is really a list of reliable Stamp Dealers. These people have studied stamps for years, perhaps they helped your father and mother when they first started their stamp collections. *St. Nicholas* knows that these dealers are trustworthy. When writing to them be sure to give your full name and address, and as reference the name of your parent, or teacher, or employer, whose permission must be obtained first. It is well also to mention *St. Nicholas Magazine*. Remember, we are always glad to assist you, so write to us for any information that will help you solve your stamp problems.



### TRIANGLE

Scarce FIUME (like illustration), also 50 other different stamps, China ship set, large \$1.00 U. S. revenue; millimetre scale, ruler and All For perforation gauge. Bargain lists and 50 to 60% approvals with every order. **FENNELL STAMP CO., 9c**  
Dept. S. Fullerton Bldg., St. Louis, Mo.

**STAMPS** 50 different Jamaica, Venezuela, etc., only 7c; 100 all different, 10c; 1000 all different, \$2.50; 100 different U. S. 25c; 1000 hinges, 10c; 50% approvals with every order. List Free. 1 buy stamps.

L. B. DOVER Dept. F. Longmont, Colo.

**BARGAINS** EACH SET 5 CENTS  
4 Iceland; 8 Finland; 20 Sweden; 8 Honduras; 8 Costa Rica; 10 Russia; 8 Dutch Indies; 4 Siam. Lists of 7000 low-priced stamps free.  
CHAMBERS STAMP CO., 111 G NASSAU STREET, NEW YORK CITY

### BOYS AND GIRLS EARN XMAS MONEY

Write for 50 sets AMERICAN CHRISTMAS SEALS. Sell for 10c. a set. When sold, send us \$3.00 and keep \$2.00.  
K. NEUBECKER, 961 East 23d St., Brooklyn, N. Y.

**STAMPS** 100 All Different, 15c. 1000 Mixed, mostly European, 30c.  
List Free. Approvals upon request  
We buy collections.  
Bymor Stamp Co. Dept. D St. Louis, Mo.

**80 STAMPS 13c.** Trengganu Leewards, Timor, Brune I. Mauritania, etc. 10 Iceland, 16c. 10 Siam, 16c. 50 Austria, 18c. 50 Germany, 18c. 50 Bavaria, 25c. 50 Asia, 18c. 50 Colonials, 16c. 50 Hungary. Brooks, 43 Edmund St., Camberwell, Eng.

**1000 AMERICAN HINGES** and 100 different stamps for 25c. 12 Austria Dues or 20 Lichtenstien free to approval applicants. Lists free.  
ELWOOD D. WEBER, 812 South Avenue, Plainfield, N. J.

**FREE** 20 Diff. British Colonies for a request for my 1, 2, 1 and 2c approvals also the higher priced stamps at 50% Discet. with extra Discets. for prompt returns.  
CHARLES T. EGNER, 1335 Pike St., Philadelphia, Pa.

**FREE** 10 Scandinavian. millimetre scale, gauge, book lists, etc., to all sending 10c for 57 diff. Siam, Ceylon, Guatemala, etc., 200 diff. 25c, 300 diff. 75c., 100 diff. U. S. 25c.  
HAWKEYE STAMP CO., Cedar Rapids, 49, Iowa.

**STAMPS—20 VARIETIES, UNUSED, FREE** to all sending for our approval sheets at 50% discount. Postage 2 cents. Mention *St. Nicholas*. **QUAKER STAMP CO., TOLEDO, OHIO.**

**FREE** 2 GERMAN AEROPLANE STAMPS to approval applicants. Reference required.  
J. R. NICHOLS, 2322 Loring Pl., New York City.

**WORLD'S LARGEST** Wholesale and Retail Catalogue of Postage Stamps now ready. 128 pages. Single stamps, sets, packets, albums, mixtures, supplies, etc. **Price 10 cents. Worth \$\$ to you. Send 10 cents today.**  
**Bargain Sets** We offer these great bargains at low prices. No two stamps alike in any set. All fine. 50 Africa 24c; 15 Arg. Rep. 11c; 50 Asia 17c; 35 Austria 10c; 35 Bavaria 20c; 10 Brazil 5c; 100 Br. Col's 20c; 25 Bulgaria 25c; 20 Chile 11c; 10 China 7c; 50 Cuba 49c; 10 Czecho's 12c; 10 Egypt 7c; 7 Iceland 20c; 50 Italy 19c; 40 Japan 7c; 8 Liberia 25c; 17 Mexico 10c; 13 Nyassa 45c; 10 Paraguay 10c; 25 Persia 25c; 6 Reunion 5c; 20 Russia 10c; 7 Siam 15c; 10 Straits 7c; 30 Sweden 11c; 100 U. S. 20c; 10 Uruguay 8c; 50 French Col's 34c; 50 Fortngnese Col's 35c. Following wonderful collections guaranteed to satisfy or your money back: 1000 varieties \$2.90; 1500 varieties \$3.45; 2000 varieties \$8.90. Postage extra. Remit in stamps or money order. We buy stamps. **MARKS STAMP CO., DEPT. N, TORONTO, CANADA.**

## READY IN NOVEMBER — 1923 EDITION — SCOTT'S POSTAGE STAMP CATALOGUE

Send in your order now. Cloth \$1.50, with thumb index \$2.00, postage extra.



**65c for 8c.** Abyssinian stamp, Guatemala Parrot stamp, Packet 30 varieties British Colonies, cat. 65c. Packet Hinges. Large mm. scale, perf. gauge and wmk. detector. Price list and finest 50% approvals all for 8c. **WE BUY STAMPS.**

**ALLEN SEARS, INC.**

Dept. S, Suite 508 Kemper Bldg., Kansas City, Missouri.



### 158 Genuine Foreign Stamps

Mexico War issues, Venezuela, Salvador and 10c India Service, Guatemala, China, etc. **Only Finest Approval Sheets 50 to 60%. Agents Wanted. Big 72-page Lists Free. We buy Stamps. Estab. 29 yrs. Hussman Stamp Co., Dept. 52, St. Louis, Mo.**

**QUICK SERVICE!** When you want stamps you want 'em want; clean, well arranged, up to date approval selections at 50% disc. with *extra discounts* for prompt returns. The general collector will be delighted. Try them and you will say "How does he do it?"  
D. M. WARD, 608 Buchanan St., Gary, Ind.  
P. S. 3 Aguinaldo Philippine Stamps free to approval applicants.

65 Different Foreign Stamps from } including Africa, Asia, Aus-  
65 Different Foreign Countries } tralia, Europe, West Indies  
and our pamphlet, which tells you "How to make your collection of stamps properly." For only 16 Cents—A BIG BARGAIN.  
**Queen City Stamp & Coin Company,**  
Room 32 604 Race St., Cincinnati, O.

Stamps 50 all diff., Africa, Brazil, Peru, Cuba, Mexico, Ceylon, Java, etc., and Album. 10c. 1000 Finely Mixed, 40c. 50 diff. U. S., 25c. 1000 hinges, 10c. Agts. wtd., 50%. List Free. 1 buy stamps.  
C. Stegman, 5940 Cote Brillante Ave., St. Louis, Mo.



(Continued on next page)



**STAMPS—(Continued from preceding page)**

**DANDY PACKET STAMPS** free for name, address 3 collectors, 2c postage, with 50% apprs. 125 dif. U. S. inc. high values, 50c. U. T. K. STAMP CO., UTICA, N. Y.

**Stamps Free** Fine set War Stamps, Surcharged, Unused, Pictorials, British, French Col's with **BIG PRICE LIST**, 2c postage. MIDLAND STAMP CO., Toronto, Canada.

**FREE** Packet of fine stamps for names and addresses 2 live collectors, and 2 cents postage. HIAWATHA STAMP SHOP, Syracuse, N. Y.

**Approval Sheets:** 50% Discount. Sent anywhere St. NICHOLAS goes. FREDERICK B. DRIVER, Doylestown, Pa.

**ALL FOR 10c** 20 STAMPS FROM 20 COUNTRIES, 10 unused and 2 Malay (Tigers). FOYE STAMP COMPANY Detroit, Michigan

**FRENCH COLONIES FREE**—Set Used and Unused Pictures, Wild Animals, Native Chiefs, Scenery and big bargain List. 2c postage. EMPIRE STAMP Co., Toronto, Canada.

**STAMPS** 105 China, etc., stamp dictionary, list 3000 bargains, 2c. Album (500 pictures), 3c. BULLARD & Co., Sta. A, BOSTON.

**FOREIGN STAMPS FREE**—Big Variety Packet Foreign Stamps from all over the World. 2c postage. GRAY STAMP Co., Station E., Toronto, Canada.

**OUR ONE CENT** each approvals are hard to beat. Premium to new applicants who send a reference. KITCHENER STAMP Co., Kitchener, Ont., Can.

**HINGES**—1000 15 cents. Packet 1000 diff. stamps, \$3.00—500 diff. \$1.50—100 diff. 10 cents. C. F. RICHARDS, BOX 77, GRAND CENTRAL P. O., NEW YORK.

**AUSTRIA** picture gallery 15 var. 11c; 45 Fr. Col. new colors 22c; 40 diff. Port. Col. 25c; 9 diff. Newfoundland cat. 23c for 8c; 1000 hinges 9c. Bargain list free. R. H. MOWER, 12 Geary St., San Francisco, Calif.

**ARGENTINE \$1.00** (cat. 20c), Cuba \$1.00 (cat. 60c), the two for 15c. Approvals at reasonable prices. References please. H. R. STEVENS, 334 Madison Street, Brooklyn, N. Y.

**200** diff. Stamps 18c; 100, 9c. 20 Persia 20c, Hinges 1000, 12c. Lists Free. MICHAELS, 5602 Prairie, Chicago.

**1500** different stamps \$5; 1000, \$2.50; 550, \$1; 300, \$.45; 200, \$.20; 100, \$.10. F. L. ONKEN, 630 79th St., Brooklyn, N. Y.

**10 STAMPS FREE WITH TRIAL APPROVALS** (Cat. 20c) F. E. THORP, Norwich, N. Y.

**FREE**—50 diff. Br. Colonies to applicants for my 60% sheets. Extra premiums. D. SEROPYAN, 53 Jeff. Rd., Webster Groves, Mo.

**4 different Morocco**, Cat. 32c, for R. H. A. GREEN, 821 Main St., Evanston, Ill. **14c**

**NEW BRUNSWICK**, 2 different, 15c. 3 different, 37c. Newfoundland, 9 different, 8c. A. C. DOUGLAS, Luan, Ont.

**FREE** Packet of stamps with 60% approvals. Send reference. H. C. BUCHHOLZ, Norwood, Ohio.

**U. S. 1917**, 7, 9, 11, and 13 cent values, 4 for 10 cents. HUB POSTAGE STAMP Co., Inc., 45 Bromfield St., Boston, Mass.

**Free Stamps** Ask for money-saving approvals. John N. Borresen, Cedar Falls, Ia.

**100** DIFFERENT Stamps 10c; 1-cent approvals. K. DYER, 5 Tremont St., Provincetown, Mass.

**ORDER TO-DAY!** 50% APPROVALS. 2238 Park Ave., BUCKEYE STAMP Co., Cincinnati, Ohio.

**ST. NICHOLAS STAMP PAGE**

(Concluded from second preceding page)

Note, too, the unusual shape and size of the stamp. ¶From Germany we picture three new stamps. First, there is a new design of the post-horn type. There seems to be quite a series of these coming, but just how many we do not know. We show the two-mark value. The second is the new German air-post stamp. Notice the queer-looking bird in the center, with a body like an Easter egg and a head that looks like a turtle. Notice that while in the upper corners are figures of value, yet there is no coin mentioned, nothing to indicate whether the face-value is twenty-five marks or the same number of pfennigs. At the bottom are the words Deutsche Flugpost. The third German stamp is the most interesting of the three. Perhaps it should really be called a Bavarian stamp, as it is issued for the special purpose of commemorating the "Industrial Exposition" to be held in Munich from May to October of this year. It seems that prizes were offered for the best designs, and many well-known artists entered the competition. Here we have the design chosen. The central portion shows the boy monk of Munich on its heraldic shield. (It may interest our readers who have time to do so to read in the encyclopedia the story of this boy whose picture appears upon the coat of arms of the city of Munich.) At the top of the design are the words Deutsche Gewerbeschau Muenchen (German Industrial Fair, Munich) 1922. Below is the inscription, Deutsches Reich, and in the bottom tablet is the value, 1½ mark. There are to be six values in the series. ¶We show a new stamp from Lithuania, with the horseman and his steed, already so familiar on the stamps of this country. But it is the coloring which makes the stamp so striking, almost barbaric, in its splendor. The rising sun at the back is brilliant red, while its rays are white. The torch-bearer is in light purple, while the horse is in dark purple. Below is the name of the country, and in each corner is the figure of value, 10 auk sinu. ¶Japan sends us a cheery little stamp. We think it is just a dear. In the upper left corner is the royal chrysanthemum, with an ornate design at each side. Below that is the usual picture of Fujiyama and, lower still, the value, 20 sen. Notice how the right-hand side is taken up by a long up-and-down picture, the entire length of the stamp, showing a pine-tree with two deer under its branches, while above it is a Japanese inscription.



## THE HILL OF ADVENTURE

By ADAIR ALDON

**A**N intensely interesting story of the search for a long-lost brother in the Rocky Mountains. The high hills, the rugged life, the narrow trails, the foreign workmen, and the strike-lockout on the irrigation project add romance and thrills to a story rich in incident and character.

*Illustrated. Price \$1.75*

### AT THE SIGN OF THE TWO HEROES

*By the same author*

An exciting tale of three courageous lads and some villainous smugglers on the shores of Lake Champlain. *Illustrated. Price \$1.75*



## WHISTLING JIMPS

By EDNA TURPIN

**A**SPIRITED and delightful story of the picturesque people who live in the Blue Ridge Mountains. The adventures of Whistling Jimps and his city-bred girl friend, Page Ruffin, are sure to hold the interest of all older boy and girl readers.

*Illustrated. Price \$1.75*

### TREASURE MOUNTAIN

*By the same author*

A thrilling tale of the adventures of a fifteen-year-old girl among the mountain whites of Virginia. *Illustrated. Price \$1.75*

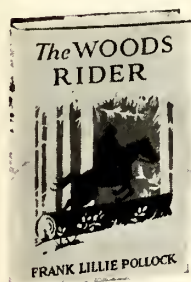

## THE WOODS-RIDER

By FRANK LILLIE POLLOCK

**A**N alluring story of bees and piney woods and pirates and danger in a delightfully new setting. The chief characters in this story are the same three young people who appeared in the author's "Wilderness Honey."

*Illustrated. Price \$1.75*

### WILDERNESS HONEY

*By the same author*

An adventure story set in the wilds of Canada, and incidentally a fascinating account of bee-raising. *Illustrated. Price \$1.75*

At All Bookstores  
Published by

**THE CENTURY CO.**

353 Fourth Avenue  
New York City





## THE PUSSYCAT PRINCESS

By EDWARD ANTHONY

**T**HE Pussycat Princess received from her royal father permission to go out into the world, taking whatever risks might befall, but for one night only. A great many things befall the Pussycat Princess on her first night out, and her adventurous lark makes an altogether fascinating and delightful story. Harry

Whittier Frees, the creator of the "Animal Mother Goose," etc., has illustrated this story with captivating photographs.

*32 full-page illustrations. Price \$2.50*

## THE CHILDREN'S BOOK OF CELEBRATED PICTURES

By LORINDA M. BRYANT

**A** WONDER-BOOK of famous pictures; fifty excellent full-page reproductions of masterpieces, with an account of the legend, historical fact, or fairy tale connected with each illustration, or some interesting anecdote about the painter. Entertaining and educational.

*Square quarto, 100 pages. Price \$2.50*

### SENTINELS ALONG OUR COAST

By

F. A. COLLINS

**A**N absorbing story account of the men and machines; a part of the biggest lighthouse service in the world, that guard 48,000 miles of coastline.

*Illustrated. Price \$2.00*

### PHANTOM GOLD

By

KENNETH PAYSON KEMPTON

**T**HE gripping story of a boy who found through thrilling experience that all the pirates did not die with Captain Kidd. A story of docks, the Atlantic coast and the open sea.

*Illustrated. Price \$1.75*

### DOG HEROES OF MANY LANDS

By

SARAH NOBLE IVES

**S**TIRRING stories of the heroic deeds performed by dogs through their devotion to their masters. And every one of the tales is true.

*Illustrated. Price \$1.75*

At All Bookstores  
Published by

**THE CENTURY CO.**

353 Fourth Avenue  
New York City



An old Favorite in a Gorgeous new Holiday Dress

# MASTER SKYLARK

By JOHN BENNETT

Author of "Barnaby Lee," etc.

¶ This story of Shakespeare's times, in which both he and Queen Elizabeth appear, has taken its place as one of those classics for young people which grown-ups also delight to read. It belongs in the class of books whose position is settled and whose interest is timeless. The story and its style are as appealing today as they were over twenty years ago, when the book was first published.

¶ "Master Skylark" has won its place alongside Kipling's "Jungle Books," Howard Pyle's "Jack Ballister's Fortunes" and five or six others that constitute the best books for young people ever written

in the English language. It has been translated into several languages and has been dramatized. It has been put on innumerable especially selected lists of juveniles year after year. It is today more popular than it ever was, and its popularity is steadily increasing.

¶ "Master Skylark" has fairly won the splendid new dress in which it now appears — has deserved the fine paper on which the holiday edition is printed, the larger type, the eight full-page illustrations in color, the many black and white designs at the beginning and end of each chapter and other decorations, all by Henry Pitz.

*Square quarto, 322 pages, with 8 full-page illustrations in color and numerous decorative figures in black and white*

Price \$3.50

At All Bookstores  
Published by

**THE CENTURY CO.**

353 Fourth Avenue  
New York City



## BY EDITH BALLINGER PRICE

**E**DITH BALLINGER PRICE was, not so many years ago, a young St. Nicholas League author. Her first published work appeared in that department when she was a young girl. It was very interesting work, and she had, besides, a double talent; for she is an artist, and illustrates the stories she writes. In but a few years she has come to be a very popular juvenile writer whose fifth book is just published — and it is, so far, her best.



### The Fortune of the Indies

A most exciting story of an old New England seaport town and of far-off China — a China of mystery and danger in which two boys have hair's-breadth escapes. It is not merely a mystery story, however: it has the quality of charm that is native to the writer; it has the atmosphere of the old days of the clipper ships. It will appeal to plot-lovers and incipient style-lovers also.

*Illustrated by the author. \$1.75*

#### BLUE MAGIC

A fascinating story of a crippled boy's adventures on the Nile and in Italy.

*Illustrated. \$1.75*

#### THE HAPPY VENTURE

An especially charming story for young people of a plucky girl and boy and their little blind brother.

*Illustrated. \$1.75*

#### SILVER SHOAL LIGHT

A story with plenty of thrill, of a summer's outing in a lighthouse on the New England coast.

*Illustrated. \$1.75*

#### US AND THE BOTTLE MAN

A juvenile with a setting by the sea and a refreshingly original plot.

*Illustrated. \$1.75*

At All Bookstores  
Published by

**THE CENTURY CO.**

353 Fourth Avenue  
New York City

## A Page of Barbour Books

# THE TURNER TWINS

By RALPH HENRY BARBOUR

A NEW STORY by Barbour is a great event to a large following of young people; and "The Turner Twins," his very latest, is in his jolliest manner, is chockful of fun, excitement and mystery, and makes the reader know as likable a group of characters as ever romped through a book.

The Twins were so much alike that no one could tell one from the other, and when having journeyed east from California they reached Hillman's School, they found the stage all set for their merry adventures. Hailed mistakenly as a football star, Ned philosophically accepted the situation, managed to conceal his colossal ignorance and won a place on the team. But it was his similarity to Laurie that saved him from disaster in the Big Game and only one other ever knew whether it was he or Laurie who kicked that winning goal and upheld the honor of the Turners!

That remarkable likeness helped again in the school entertainment and even Polly Deane, whose widowed mother kept the tuck shop, was startled. Polly was a great pal of the Twins, especially of Laurie, and it was Laurie who discovered the explanation of the mysterious sounds beneath the widow's cottage, solved the problem of what had become of old Coventry's money and so brought a happy Christmas to Polly and her mother.



*Illustrated. Price \$1.75*

### Other Books by Barbour

**Captain Chub.** Illustrations by Relyea. 12mo, 400 pages. \$1.75.

**The Crimson Sweater.** A capital story of athletics. Illustrated by Relyea. 12mo, 367 pages. \$1.75.

**Crofton Chums.** Illustrations by Relyea. 12mo, 338 pages. \$1.75.

**Harry's Island.** Pictures by Relyea. 12mo, 306 pages. \$1.75.

**Kingsford, Quarter.** Illustrated by Relyea. 12mo, 326 pages. \$1.75.

**Team-Mates.** Illustrations by Relyea. 12mo, 400 pages. \$1.75.

**Tom, Dick, and Harriet.** Illustrations by Relyea. 12mo, 384 pages. \$1.75.

### Books by Barbour and H. P. Holt

**The Mystery of the Sea Lark.** Illustrated. \$1.75.

**Fortunes of War.** Illustrated. \$1.75.

**Lost Island.** Illustrated. \$1.75.

At All Bookstores  
Published by

**THE CENTURY CO.**

353 Fourth Avenue  
New York City



## *The Nature Books of Jean-Henri Fabre*

---

# A WONDER BOOK OF CHEMISTRY

This newly translated book by the great Frenchman will give any lively-minded, curious youngster a genuine insight into those mysteries of chemistry which, together with physics, form the foundation facts of our material world. Nothing is more marvelous than chemistry, and M. Fabre was a genius who felt and has conveyed the pure delight of its discovery, the intellectual joy there is in it. When chemistry can be made interesting to the point of being positively exciting — why should not eager young minds have wonder-tales that are true, and that are a true initiation into their world? This is a delightful, an excitingly interesting book. It is inevitably destined to prove a classic, and should be in the hands of every child.

*Illustrated, 8vo, 400 pages; price \$2.50*

### **OUR HUMBLE HELPERS — THE DOMESTIC ANIMALS.**

A particularly delightful book for children which will make every friendly animal more interesting and intimate.

*Illustrated, 8vo; \$2.50*

### **FIELD, FOREST AND FARM.**

Charming and useful lore of farming, gardening and fruit culture, set forth especially for young people.

*Illustrated, 8vo; \$2.50*

### **THE SECRET OF EVERY- DAY THINGS.**

Quaint and curious scientific information about the familiar objects of everyday life, charmingly presented.

*Illustrated, 8vo; \$2.50*

### **THE STORY-BOOK OF SCIENCE.**

A general account of the earth and its creatures which is as fascinating as it is accurate.

*Illustrated, 8vo; \$2.50*

## **ANIMAL LIFE IN FIELD AND GARDEN**

Stories of the more familiar wild life to be observed about country homes, treated from the standpoint of its relation to human life. Insect and mammal, bee and bat, make man's life easier or harder, his food scantier or more plentiful. "Uncle Paul" tells two little boys very surprising and entertaining stories of the creatures so important to man.

*Illustrated, 8vo; \$2.50*

---

At All Bookstores  
Published by

**THE CENTURY CO.**

353 Fourth Avenue  
New York City

**A New Mystery Story**

**By the Author of "The Boarded-Up House"**

**By Augusta Huiell Seaman**



## **THE MYSTERY AT NUMBER SIX**

**N**EAR an abandoned Florida phosphate mine, still known as "Number Six," that has long ago turned into a beautiful pool, two cousins, a boy and a girl, stumble upon an inexplicable affair. This affair entangles them in the exciting adventures related in this story.

There is a young girl whose history and parentage have been kept a secret, and old Jerry Saw-Grass, her half-bred Indian guardian, who anxiously tries to avert meeting Mr. Tedwell, the New York lawyer. About these characters revolves the baffling mystery that is finally solved with the aid of the two cousins.

*Illustrated*

*Price \$1.75*

**By the Same Author**

**THE BOARDED-UP HOUSE.** About the mystery found in a deserted house.

*Illustrated. Price \$1.75*

**THE DRAGON'S SECRET.** Another of this author's thrilling mystery stories.

*Illustrated. Price \$1.75*

**THE SAPPHIRE SECRET.** A mystery story with a picturesque and historical background.

*Illustrated. Price \$1.75*

**THREE SIDES OF PARADISE GREEN.** The Imp and the two girls discover one of the most interesting places in the world.

*Illustrated. Price \$1.75*

**THE GIRL NEXT DOOR.** Tells the secret of the girl next door.

*Illustrated. Price \$1.75*

**THE CRIMSON PATCH.** A tale of spies, danger, and secret conspiracies.

*Illustrated. Price \$1.75*

**THE SLIPPER POINT MYSTERY.** How a summer visitor and the boatman's daughter solved the mystery.

*Illustrated. Price \$1.75*

**MELISSA-ACROSS-THE-FENCE.** About Melissa and the little boy in the grand house.

*Illustrated. Price \$1.50*

**Published by**

**353 Fourth Ave.**

**THE CENTURY CO.**

**New York City**

*On Sale At All Bookstores*



*A Delightful New Story*

*By the Authors of "The Luck of Denewood," etc.*

By E. B. and A. A. Knipe

# THE FLOWER OF FORTUNE



**A** THRILLING story of courage, generosity, independence, and love, set in the old New York of Dutch and English days. The plot concerns itself mainly with the Dutch inhabitants and the quaint picture the authors draw is wonderfully convincing and interesting.

The clear-eyed confidence of the heroine and the spirit with which she meets many difficulties and mysterious troubles will win sympathy, as the triumph and success which come to her, and the pretty love story of which she is the heroine, will be thoroughly enjoyed.

*Illustrated by E. B. Knipe. Price \$1.75*

*By the Same Authors*

**THE LUCKY SIXPENCE.** The first Denewood story. About a little English girl in the colonies.

*Illustrated. Price \$1.75*

**BEATRICE OF DENEWOOD.** The sequel to "The Lucky Sixpence."

*Illustrated by Relyea. Price \$1.75*

**THE LUCK OF DENEWOOD.** The third story of the popular Denewood series.

*Illustrated. Price \$1.75*

**THE LOST LITTLE LADY.** A mystery story set in New York during the Civil War.

*Illustrated. Price \$1.75*

**A MAYFLOWER MAID.** A girl's adventures among the early settlers.

*Illustrated. Price \$1.75*

**VIVE LA FRANCE!** An inspiring story of World War times.

*Illustrated. Price \$1.75*

**PEG O' THE RING, OR A MAID OF DENEWOOD,** in which Peggy of Denewood meets with many exciting adventures.

*Illustrated by Relyea. Price \$1.75*

*Published by*

353 Fourth Ave.

**THE CENTURY CO.**

New York City

*On Sale At All Bookstores*

---

## TO OUR READERS

¶ Now that the camping season for 1922 is over, ST. NICHOLAS is anxious to start collecting data in regard to the season's work. We should like to have our readers feel free to write us about their experiences at camp this summer. ¶ Tell us if you were pleased with your camp and, if you feel so inclined, kindly write to us about the particular features of your camp that you liked best of all. ¶ On the other hand, if you experienced anything that was not up to standard or in keeping with your ideas of a fine, high-class summer camp, please write us about this, too, and you may be assured that we shall consider your correspondence very personal.

CAMP SERVICE BUREAU  
ST. NICHOLAS MAGAZINE

---

# Golf an Old Man's Game!!!

When the National Open Champion, The National Amateur Champion and two other semi-finalists in the Amateur Championship are under twenty-one years of age, golf seems to be a pretty fair game for the boys.

Learn to play the game well, boys. Start young. THE AMERICAN GOLFER, THE SPORT PICTORIAL, tells you how to learn. Also it tells you, every two weeks, what is going on with the stars of the game, how and why they succeed.

Edited by Grantland Rice, the greatest sport writer in the country, this magazine is made to order for boys. Subscribe now. Use the coupon below.

CENTURION PUBLISHERS, INC.  
353 Fourth Avenue, New York City

S.N. 10-22

Enclosed find \$5.00, for which send me THE AMERICAN GOLFER, THE SPORT PICTORIAL, for one year (26 issues).

Name .....

Address .....

Postage in Canada, 50 cents; foreign countries, \$1.00.



It's Ten to One You Are  
Healthier Than You Think

# OUTWITTING OUR NERVES

By

JACKSON, M.D., and SALISBURY

THE most cheerful, the most readable, the most helpful, the most successful, the most enthusiastically endorsed book on better health that has been published in years. Doctors are prescribing it. The reviewing press has given columns to both the authoritative subject matter and the delightful style of the book.

It does not indulge in vain platitudes about worry and will power; it shows the real reason for worry and the blues. There are chapters on the Subconscious Mind, The Real Trouble, The Way Out, That Tired Feeling, Dietary Taboos, The Bugaboo of Constipation, Insomnia, Woman's Handicap, and others equally vital. Some of these chapters will revolutionize the habits of a life-time.

A great part of all disease is functional: organic disease is far less common. Functional diseases are curable and it is the great discovery of psycho-analysis that they are often removed by just understanding their nature and gaining a right mental attitude. "Outwitting Our Nerves" is an invaluable aid to the achievement of such an attitude. It reveals how many kinds of disease can result from mistaken mental attitudes; tells how not to be sick when there is no real reason for staying sick; how to face your difficulties, know what they are and how to deal with them; how to live, fully, bravely, happily.

33rd thousand. Price \$2.50

## Press Comments:

**The New York Evening Post:** There is not a shimmer of a doubt but that one-half the people in the United States could read this volume with profit.

**Boston Transcript:** It is a particularly practical book, certain of being useful to large numbers of people.

**The New York Times** (In a page review by Van Buren Thorne, M.D.): Contains explanations of the Freudian principles in their simplest form and is therefore invaluable to those whose knowledge of them is vague or confused.

**Pittsburgh Dispatch:** It is written in an admirable style, never ponderous, but as bright as the cheerful message it brings.

**Boston Herald:** Not just another book about a new kind of treatment, not just another psychic book, but a book of good sense, good reading and good medicine.

**Baltimore Evening Sun:** A scientific book, but its authors have the knack, which was so wonderfully developed by Professor William James, of putting the truths of science into clear, epigrammatic, idiomatic English.

**Buffalo Commercial:** We may thank the authors for the clear manner in which they have explained much that has to do with the discoveries of Freud.

At All Bookstores  
Published by

THE CENTURY CO.

353 Fourth Avenue  
New York City



Action and Color and Conflict

# WEST!

By CHARLES ALDEN SELTZER

Author of "The Two-Gun Man," etc.

A SWIFTLY moving Western story, with an engaging love theme and a conclusion that will please a host of new readers as well as the author's many old friends. Mr. Seltzer has never before so finely presented the spell of the open plains and the romance of the cow country.

*Illustrated. Price \$1.90*

## WINTERGREEN

By JANET LAING

A N absorbing, jolly and refreshing love-story set in a little Scotch village on the rocky seashore, old and clean and individual. It is as amusing and human and thoroughly delightful as "When Bunty Pulls the Strings," and Barrie's "What Every Woman Knows."

*Price \$1.75*

## SEA WRACK

By VERE HUTCHINSON

A POWERFUL love-story in which are combined keen characterization, rich personality, fine and poignantly-felt writing, and a setting strangely alive and memorable. Already a marked success in London, where the reviewers compare it with "Wuthering Heights."

*Price \$1.75*

## LETTERS TO A DJINN

By GRACE ZARING STONE

A FASCINATING narrative unfolding a charming love-story and giving the reader the color and flavor of alluring, romantic, far-away places in the Pacific. It is a series of letters with the charm of intimacy, the stimulus of spirited dialogue, and the carefree style of a jolly correspondent.

*Price \$1.75*

## ONE WORLD AT A TIME

By MARGARET FULLER

A N entrancing and exquisite story of plantation days in almost tropical South Carolina some twenty years after the Civil War. It carries the reader into a world that is strange, enticing, utterly other than the everyday of life.

*Price \$2.00*

**THE CENTURY CO.**

At All Bookstores  
Published by

353 Fourth Avenue  
New York City



*Five New Century Novels*

# THREE BLACK BAGS

By MARION POLK ANGELLOTTI

Author of "*The Firefly of France*," etc.

THIS gripping, appealing mystery story swiftly carries the reader in delighted suspense through plot and counterplot, through dangers innumerable and on to a most surprising and yet satisfactory conclusion. The story is set in France and Germany and revolves about a beautiful and resourceful American girl.

Price \$1.75



# WHISPERING SAGE

By HARRY SINCLAIR DRAGO  
and JOSEPH NOEL

AN absorbing love-story of the Western sage-brush country with strong plot-interest, swift movement, suspense, and a good deal more than the usual feeling of real life, real concern for the fate of genuine characters.

Price \$1.75

# MUMMERS IN MUFTI

By PHILIP CURTISS

THE highly amusing story of a relic of the Victorian age, who suddenly finds himself the owner of a whole theatrical production, and manager of a pretty, temperamental actress. Mr. Curtiss has never used his light, gay, sophisticated style on a more charming theme.

Price \$1.75

# THE REST HOLLOW MYSTERY

By REBECCA N. PORTER

THIS thrilling mystery story is set in a deserted California mansion, where a cold-blooded adventurer, two clever women, a famous scientist, and chance itself, play a game with the life and happiness of an extraordinary young man with whom every reader will sympathize.

Price \$1.75

# FIVE NIGHTS AT THE FIVE PINES

By AVERY GAUL

THE tale of a haunted house and the history of Mattie, whose last name was taken from a ship; a woman who lived a strange life shut off from the world in a sea captain's old house on Cape Cod.

Price \$1.75

**THE CENTURY CO.**

At All Bookstores  
Published by

353 Fourth Avenue  
New York City



# ATOLLS OF THE SUN

By *FREDERICK O'BRIEN*

Author of "White Shadows in the South Seas"  
and "Mystic Isles of the South Sea"

A FASCINATING record of the author's travels among those blazing coral wreaths upon the Equatorial Pacific known as the Dangerous Archipelago, which are among the most amazing habitations of man. Mr. O'Brien spent months among the Paumotuans, taking part in their daily lives.

Moreover, he tells of further adventures in the Marquesas Islands, and the reader meets once more Exploding Eggs, Vanquished Often, Daughter of the Pigeon, Seventh Man Who Wallows in the Mire, and others of those memorable figures that appeared first in "White Shadows in the South Seas."

*Illustrated. Price \$5.00*

**THE CENTURY CO.**

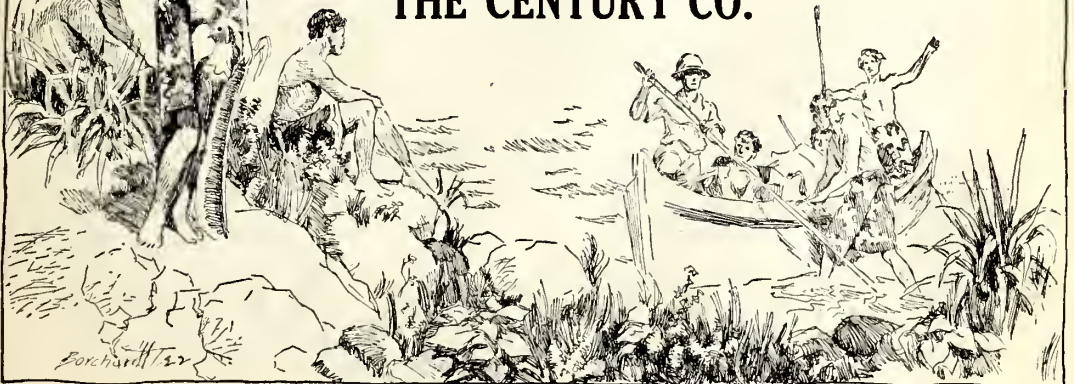

*Forchardt 22*





“AD”  
VENTURES of the

IVORY HEROES



## Cobwebs and Thunder Men

### Chapter X

SO having cleaned a comet up and sent him on his way our little IVORY bubblers were quite ready for some play. They wanted very much to find those cobwebs hanging high which “that Old Woman with her broom would sweep from off the sky.” “If there are cobwebs,” Betty said, “it’s very safe to say that there are other kinds of dirt that we should wash away.”

They found some dingy cupboards in the dim, unstarry places, where rain and thunder clouds had let the spiders spread their laces. *What do you think those cupboards held?*

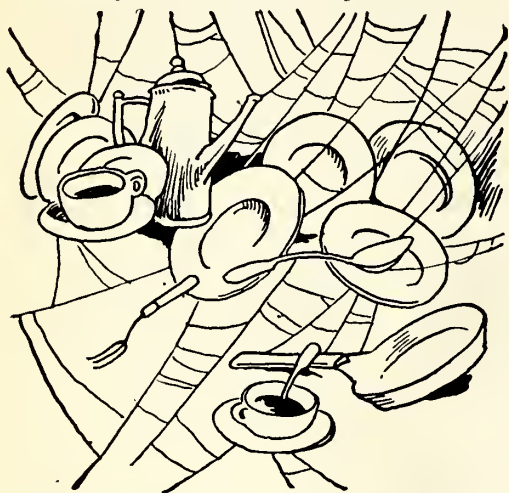

Why, long, uneven rows of unwashed dishes in such heaps the doors refused to close! The naughty Thunder Makers would not clean up

Then they hunted  
Thunder Men.



after meals—that’s how a Thunder Maker shows the naughty way he feels. Now, IVORY does dishwashing *best*—no soap can do it better, and Betty said she’d “clean things up,” and Gnif and Bobby let her.

Then they went hunting Thunder Men with Yow and Snip for scouts. They’d hunted just a little while when Betty heard their shouts. They’d rounded up the Thunder Men—a glowering, gloomy crowd, who came, but very sulkily and grumbling long and loud. Gnif made them scrub the cupboard shelves and wipe the dishes dry. When they were through there was no sign of cobwebs in the sky. Then Betty showed them IVORY SOAP and gave each one a cake. They grew quite chipper when they found what bubbles it would make. They promised they would not neglect their dishes any more while there remained a single cake of IVORY in their store.

*Yes, with a soap like IVORY,  
Dishwashing is but fun;  
Your work is finished perfectly  
When it is scarce begun.*

Don’t you want to see how and when these marvelous adventures began? Then write to your friends, The Procter & Gamble Co., Cincinnati, Ohio, asking for a little book called “THE CRUISE OF THE IVORY SHIP,” by John Martin. It is a wonderful little bedtime book, given *FREE* to you.



IVORY  
IT FLOATS



SOAP  
99 <sup>44</sup>/<sub>100</sub> % PURE





THE NIGHTMARE.  
Mother! I was dreaming  
that Jimmie stole my  
**JELL-O**







# Two Friends on Guard



for Sturdy  
Boys

Large tubes 25c—  
Why pay more?

**T**WO of the best friends a boy can have are Colgate's Ribbon Dental Cream and the tooth-brush.

Colgate's should be used twice a day by every boy who wishes to be strong and healthy. The boy who neglects his teeth and permits them to decay is likely to be stunted in his growth.

Girls, too, should give their teeth daily care, if they wish to be healthy and beautiful.

Colgate's cleans teeth the right way—*safely* and *thoroughly*. It is recommended by more dentists than any other dentifrice. The delicious flavor makes its use a treat, not a task.

Ask your parents to buy Colgate's—or send 2c in stamps for a generous trial tube.

COLGATE & CO., Dept. 60, 199 Fulton Street, New York















