

THE AMERICAN

ELEVATOR AND

GRAIN TRADE



LIBRARY
RECEIVED
MAY 19 1930

Printed in U. S. A. Entered as second-class matter June 26, 1885, at the Post Office at Chicago, Illinois, under Act of March 3rd, 1879 Established 1882

PUBLISHED BY Mitchell Brothers Publishing Co. } A MONTHLY JOURNAL DEVOTED TO THE ELEVATOR AND GRAIN INTERESTS. } One Dollar Per Annum SINGLE COPIES, 15 CENTS

VOL. XLVIII 431 South Dearborn Street, Chicago, Ill., May 15, 1930 NO. 11

Of Course

We want your business but we want it on a basis that will pay you as well as ourselves. We want it because we have proper facilities for handling it.

Don't be satisfied with slow returns or poor service; send your shipments to

McKenna & Strasser
GRAIN
Room 877, 538 South Clark
CHICAGO

GRAIN DRIERS
FEED MIXERS
FEEDERS
STEAM COILS
COOKERS
MOLASSES
HEATERS



ROTARY DRIERS
TRUCK DRIERS
STERILIZERS
FANS
STEAM TRAPS
OAT BLEACHERS
SPECIAL DRIERS

ELLIS DRIER WORKS

Division of G. L. M. Corp.
822 West Washington Blvd. Chicago

When You Want **QUALITY**
Dried Buttermilk
Dry Skim Milk

For Animal and Poultry Feed
Wire, write or phone us for
Fresh Product Direct from 60 Plants
Packed in 100-lb. Paper Lined Sacs
Prompt or Deferred Shipments

FEED FORMULAS
FEED PLANT EQUIPMENT
FEED SYSTEM ENGINEERS

S. T. EDWARD & CO.
INC.
110 N. Franklin St., Chicago, Ill.
Phone Randolph 1547

SELL or RENT Form Lifting JACKS

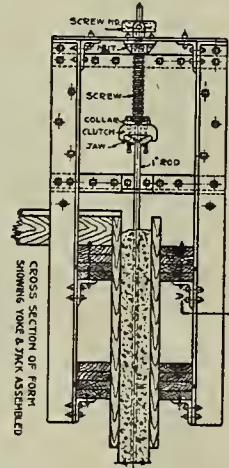

Grain
Elevators,
Silo Coal Pit
Construction
Blue Prints
Furnished

NELSON MACHINE CO.
WAUKEGAN, ILLINOIS

CALDWELL ELEVATOR DRIVE



HERE is a new standardized elevator drive, built to operate centrifugal discharge, perfect discharge or continuous elevators requiring 3 to 15 horsepower.

The entire line is standardized and carried in stock. The arrangement of the drive unit is shown in the accompanying illustrations.

The first reduction from the motor is a fully enclosed worm gear speed reducer to which the motor is connected through a flexible coupling.

The second reduction in speed is through a roller chain and sprocket, also providing a flexible connection between the reducer and headshaft.

Send for a copy of Book No. 1086.

H. W. CALDWELL & SON CO.
LINK-BELT COMPANY, OWNER

CHICAGO 2410 West 18th Street NEW YORK 2676 Woolworth Bldg. DALLAS, TEXAS 1101 Mercantile Bank Building Offices in Principal Cities C-121D



Reliance Construction Company

Furnish Plans, Estimates and Build
COUNTRY GRAIN ELEVATORS

Our long experience as a builder of elevators insures you an up-to-date house. Write today.

Board of Trade Building, INDIANAPOLIS, IND.

"THE CLIMAX" SCOOP TRUCK

CAPACITY { 200 Lbs. Coal
 { 2 1/2 Bushels Grain

Can easily add Twenty-five cents an Hour to the value of a man's time who uses it in unloading Coal or Grain from box cars. Hence, in two weeks' use the Scoop-Truck will pay for itself and cost you nothing for its use thereafter. It will last for years and save the wearing out of a dozen common scoops in doing a like amount of work. Hundreds have tried it and will certify to the truth of these statements. Why not order now, and let the Scoop-Truck be giving itself to you?

Patented July 30, 1907

PRICE: \$15.00 F. O. B. cars at factory
Detroit Scoop Truck Co., 993 Osborne Place, Detroit, Mich.

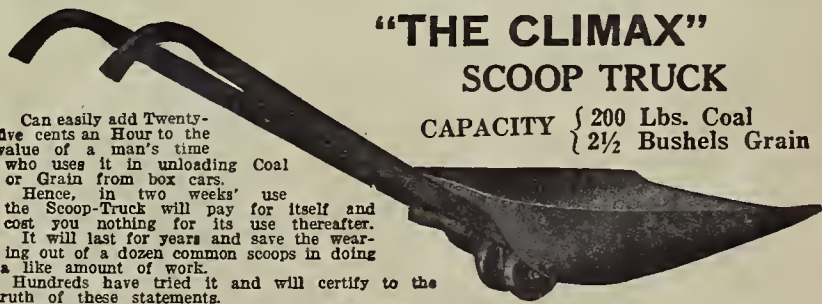

DIAMOND RUBBER CO. INDUSTRIAL NEWS

Diamond Grain Belts

Keep Things Moving at St. Joseph



Left—Photo shows the latest addition to The Quaker Oats Company's plant at St. Joseph, Mo., completed last October by The Leonard Construction Company. Equipped with Webster machinery.

IN THE package building group of The Quaker Oats Company's St. Joseph plant, Diamond Grain Belts are on the job, working steadily.

The latest improvements in this plant, completed last fall by The Leonard Construction Company, include the following Diamond-made belts, as part of the equipment:

Three bin floor conveyors, 42" 4-ply, 32-oz. duck, totaling 1,132 ft.

Two dumper house conveyors, one 42"

5-ply, 32-oz. duck, 162 ft. long; one 48" 5-ply, 32-oz. duck, 63 ft. long.

Three additional Conveyors 36" 4-ply, 32-oz. duck, totaling 598 ft.

The selection of Diamond belts by acknowledged experts, for use in the most modern and efficient plants in the country, is the best possible proof of their unquestioned quality, and their steady, reliable performance.

The purchase of Diamond Grain Belts insures economy also, for they give many long years of service.

THE DIAMOND RUBBER COMPANY, INC.

Distributors in most principal cities. Branches as follows:

Akron / Atlanta / Kansas City / New York / Philadelphia
Boston / Dallas / Chicago / Los Angeles / Seattle / San Francisco



CRACKELS—an appetizing, new cereal, a composite of corn, oats and wheat. Product of The Quaker Oats Company.

Diamond

RUBBER BELTING



HOSE • PACKING

One of World's Largest Elevators

SANTA FE ELEVATOR A

*Is Fully Equipped with WEBSTER transmission
and conveying machinery*



Santa Fe Elevator A in Kansas City operated by the Davis-Noland-Merrill Grain Co. ranks among the world's largest elevators, having an unloading capacity of 200 cars and a loading capacity of 250 cars within a normal working day. Its total storage is 6,000,000 bushels.

This huge house is equipped throughout with WEBSTER machinery. It is one of the most economically operated houses in the world and WEBSTER equipment is largely responsible for its economy in operation.

*WEBSTER equipment is patterned with care and well designed,
and the most durable that can be manufactured
It is the standard for elevator equipment.*

For Over 50 Years

The names of Webster and Weller have been familiar to the grain trade as manufacturers of high grade machinery. During this period most of the large, as well as the smaller Elevators have depended on us for their elevating, conveying and power transmitting machinery.

That it has served its purpose well, is attested by the fact that when an elevator increased its capacity, Webster or Weller machinery was usually specified.

Because it is better fitted and more carefully designed it reduces installation costs and difficulties; also reduces renewal and repair bills.

A Few of Our Products

Apron Conveyors	Elevator Boots	Power Shovels
Belt Conveyors	Elevator Casing	Car Pullers
Chain Conveyors	Elevator Heads	Dock Spouts
Mixing Convey- ors	Bag Elevators	Pulleys
Screw-Conveyors	Elevator Spouts	Hangers
Bucket Elevators	Malleable Chain	Sprockets
Elevator Buckets Etc.	Friction Clutches	Gears

For equipment plans for your project, consult with us.

WEBSTER MFG. CO.—WELLER MFG. CO.

Plant at Tiffin, Ohio

Plant at Chicago, Ill.

General Offices

1856 N. Kostner Ave.

Chicago, Ill.

Webster Brinkley Co.
Seattle, Wash.

Webster-Inglis, Ltd.,
Toronto, Ont., Can.

The Michigan City Foundry Co.
Michigan City, Ind.

Sales Offices

Buffalo

Cincinnati

Cleveland

New York

Philadelphia

Pittsburgh



"Eureka" - "Invincible" Grain Cleaning Machinery

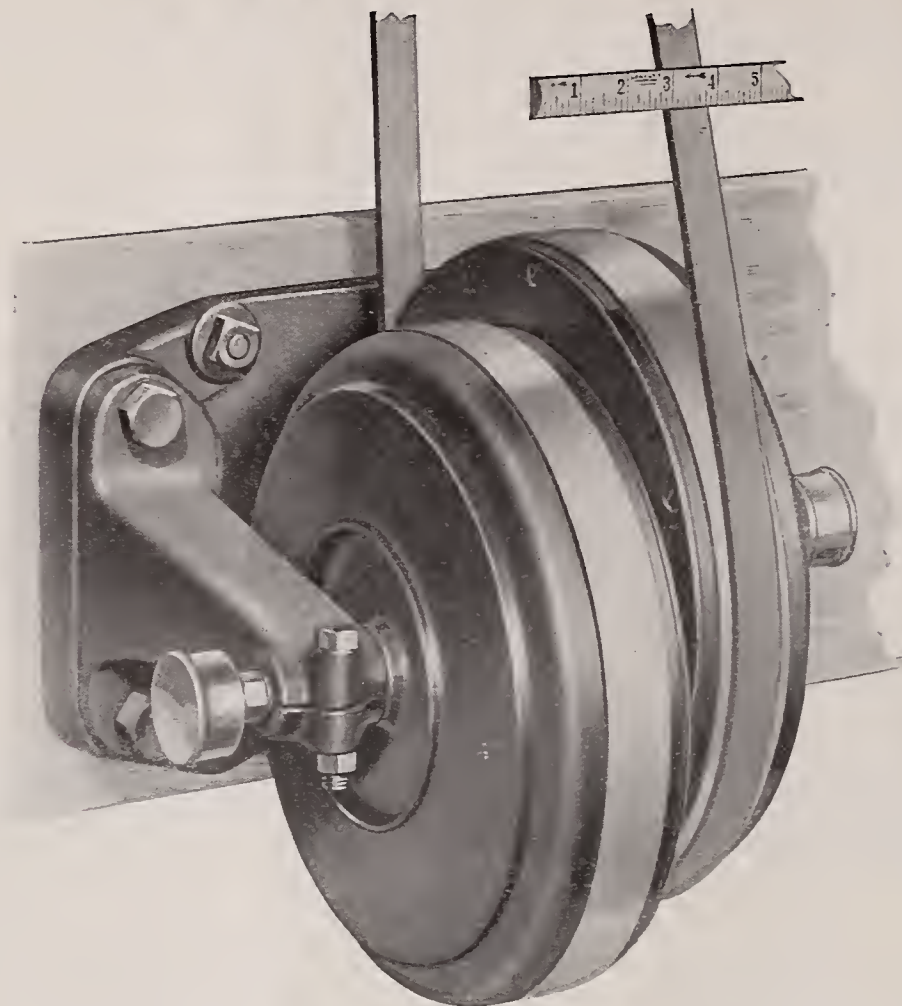

Driven
By One Inch Belt

Only
Two Moving Parts

"EUREKA" BUHLER DRIVE

WHAT IT IS

A patented oscillator which when attached to the shoe of a separator entirely does away with the customary eccentric shaft, the eccentrics, connecting rods and counterbalances, post boxes, collars and pulley heretofore used for imparting motion to the sieves of Separators, Graders and Shoes. It is applicable to both new and old "Eureka" and "Invincible" machines and to many old ones of other makes.

WHAT IT DOES

Removes every vestige of vibration. Balances shoe automatically, hence no bracing required. Stops all noise—absolutely silent. Reduces power consumption enormously. Increases capacity greatly. Insures more satisfactory screenings extraction. Takes care of itself—never needs adjusting. Upkeep costs nothing—repair bills eliminated. Cleaner and safer than eccentrics.

AND SO EASY TO ATTACH

A handy-man can install it in a few hours; just bore four holes and bolt the "Eureka-Buhler" to shoe. Easily driven by open belt with $\frac{1}{4}$ H.P. motor or by countershaft; no $\frac{1}{4}$ twist drive or idler or tightener required.

Write for Catalog AE 125

S. HOWES CO., Inc.

INVINCIBLE GRAIN CLEANER CO. SILVER CREEK, N.Y.



"EUREKA" - "INVINCIBLE" GRAIN CLEANING MACHINERY

NO CASH TO PAY FOR THE MIRACLE MOLASSES PROCESS!



Pay for this wonderful cold molasses process entirely out of your profits. We have found that the credits we have extended in the sale of the MIRACLE MOLASSES PROCESS are 100% good — everybody makes money and is enabled to pay for the process out of their profits.

So if you have the grinding equipment—it does not matter what kind of grinding machines you may have—we will sell you the size MIRACLE MOLASSES PROCESS you may need without any cash payment and give you two years in which to pay for it.

If you have no grinding equipment we will sell you the most efficient, largest producing and best built hammer mill, THE MIRACLE ACE HAMMER MILL, on terms that will enable you to soon pay out on it.

Remember our Service Department will tell you all you have to know about making sweet feeds, all about how to do, for the first time, custom sweet feed milling. There are no secrets about this business. We will show you how you can make better and cheaper sweet feeds than are or can be shipped into your community—no competition to fear.

Here is your opportunity to get into the most profitable part of modern day milling—more millions have been made out of manufacturing the balanced sweet feed ration than ever were made out of flour milling.

Write us at once, today, about your situation and requirements, let us send our booklet the "Miracle Sweet Feed System," and follow it with one of our engineers to figure on your installation.



ANGLO AMERICAN MILL CO.

240-266 Kennaday Ave.

Owensboro, Ky.

The World's Largest Builders of Grain Grinding Machinery

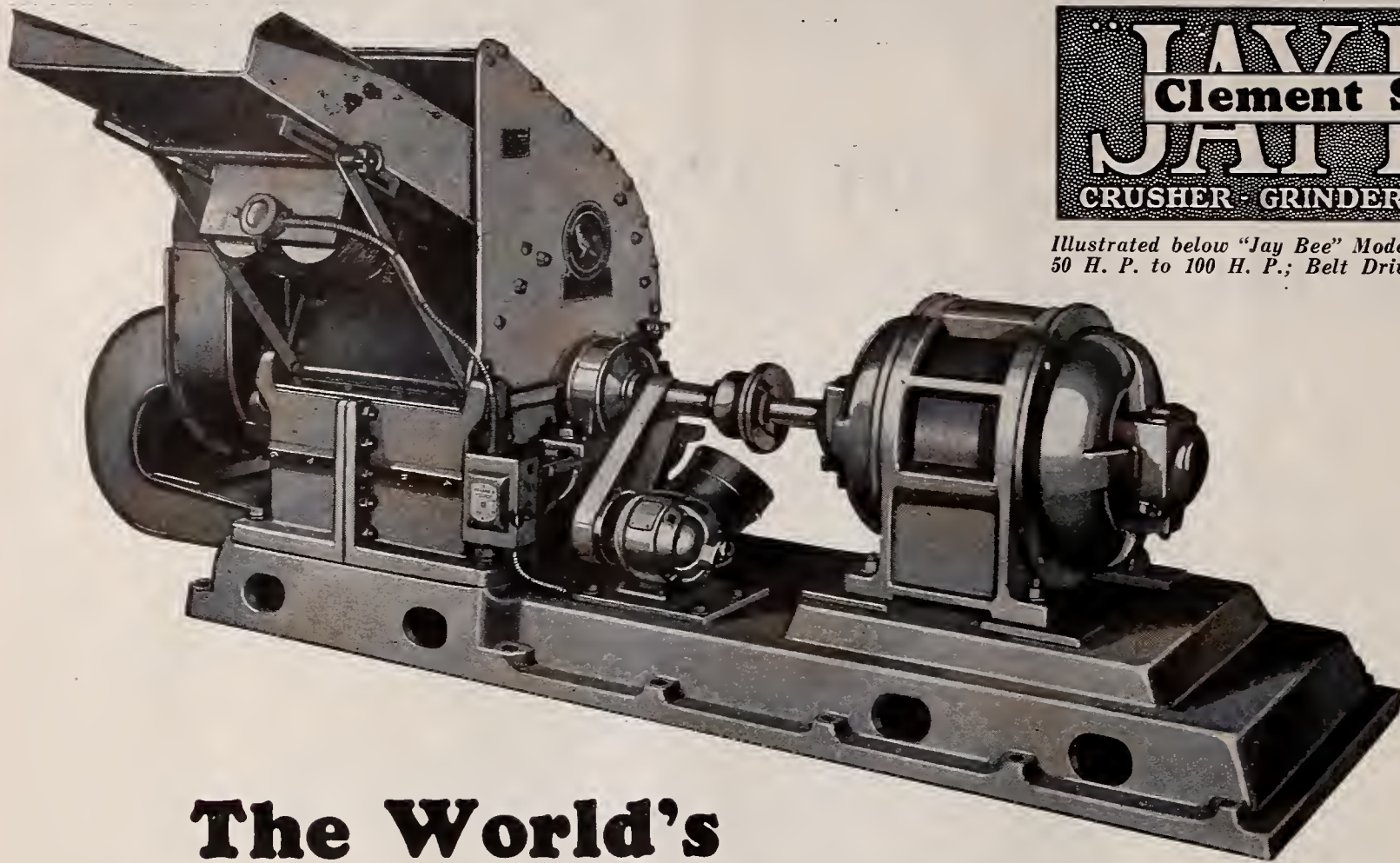

Illustrated below "Jay Bee" Model "W": Direct Connected 50 H. P. to 100 H. P.; Belt Driven 50 H. P. to 75 H. P.

The World's Undisputed Low Cost Big Capacity Champion Feed Grinder

Feed Grinders Come and Go—but wher ever installed, the "Jay Bee" "stays put."

Regardless of All Competitive Claims about capacity, operating and maintenance expense the fact remains that the "Jay Bee" is going into plants where other mills have been tried out and failed to make good. This is proved by the fact that there are more "Jay Bee" mills operating in the milling industry than all other hammer mills combined.

Success in Selling "Jay Bee" Mills is dependent only upon efficient and economical operation. It is this kind of grinding that has lifted millers and custom grinders out of the rut and made successful, money-making businesses—it is "Jay Bee" unequaled quality grinding that keeps these establishments making money for their owners and serving their customers better than ever—it is "Jay Bee" dependability which makes possible expansion in the most profitable way, and which makes possible the creating of profitable new grinding establishments in communities not having a custom milling plant.

Prove These Statements Yourself. Go into any community, and you will find this predominance of "Jay Bee" mills over all other hammer feed grinders. If the "Jay Bee" were not better than all other hammer mills this would not be the case.

If You Want Real Grinding Satisfaction—if you want to start grinding feed for all the profit you can make—if you want to expand your already established business, and operate it on a more economical and profitable basis, the "Jay Bee" is the mill you need.

Whether You Have a Small or a Large Plant we have a "Jay Bee" mill to meet your exact needs. The "Jay Bee" is made in sizes and styles for every grinding requirement: From 12 H.P. to 100 H.P. for belt, V-belt and direct-connected drives. Write for literature and complete details.

Manufactured by the Bossert Corp., Utica, N. Y., the world's largest hammer mill manufacturer.

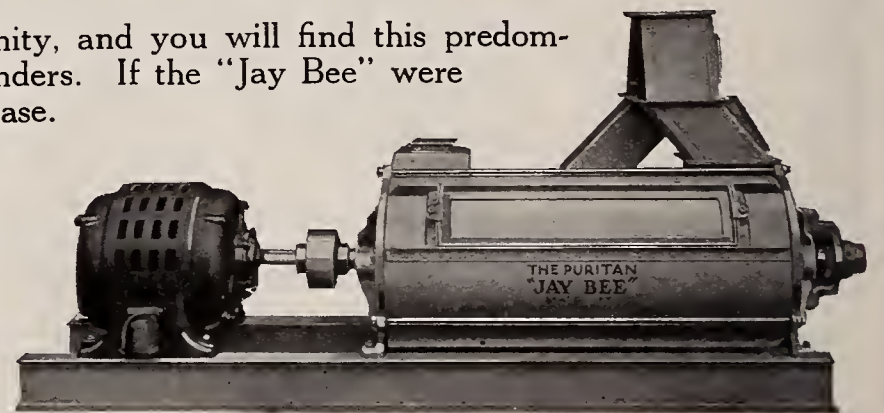

Puritan "Jay Bee" Molasses Mixer

The only Molasses Mixer made that will mix cold molasses in any proportion without balling the feed. As nearly perfect as science and mechanical skill can produce. Its efficiency and capacity are in keeping with the undisputed superiority of the World Famous "Jay Bee" mill.

J. B. SEDBERRY, Inc., 74 Hickory St., Utica, N. Y.

J. B. SEDBERRY CO., 819 Exchange Avenue, CHICAGO, ILL.

**JAY BEE SALES CO. 319-325 Live Stock Exchange Bldg., Kansas City, Mo.
311-312 Terminal Warehouse Bldg., Omaha, Neb.**

TETRAFUME

(Registered)

the wonder insect killer

Kills Weevil and Moths also Kills Rats and Mice

RIDS YOUR PREMISES OF THESE PESTS

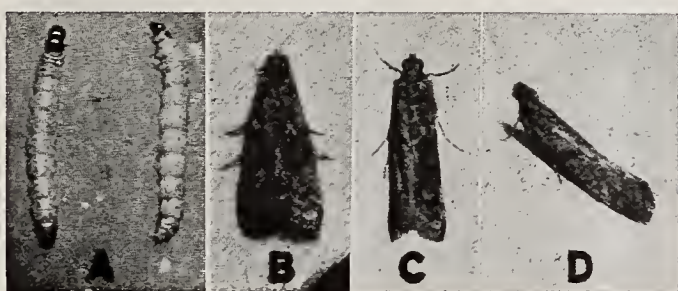

It Is Non-Inflammable—Non-Explosive—Approved by Fire Insurance Companies

Harmless—Stainless—Leaves No Odor

Also cools grain so it will not heat in bin or car

High moisture content—
from rains and combine
—help to breed weevil
and other insects. For
protection keep a drum
of Tetrafume constantly
on hand.

Guide No. 540 I6. January 7, 1930—Laboratories' File MH2077.

Douglas Chemical & Supply Co., Mfr.,
829-831 Southwest Blvd., Kansas City, Mo.

Fumigant.

Composition of product is regarded as a trade secret and is on file at Laboratories. It
is intended for use as a fumigant.
Marking: "Tetrafume" on containers.

LISTED—Fire—Non-combustible—Non-flammable.

REEXAMINATION SERVICE.

See description of Reexamination Service on guide card.

This card is issued by Underwriters' Laboratories.

The falling off in exports
of grain, mixed feeds,
flour and other grain
products is attributed to
weevil infestation.

See reproduction of approval by Underwriters' Laboratories.

TETRAFUME IS DEATH
TO THIS FELLOW AND
HIS TRIBE



Write today for
further particulars
and price list.

DOUGLAS CHEMICAL & SUPPLY CO.

901-903 Southwest Boulevard

KANSAS CITY, MO.

Associate Member Grain and Feed Dealers National Association.
Nebraska Grain Dealers Association.

A discount of 10 per cent from list price
will be allowed on all orders—having
this coupon attached to same,
during the next thirty days.
American Elevator &
Grain Trade,
May, 1930

DOUGLAS CHEMICAL & SUPPLY CO.
829 Southwest Boulevard, Kansas City, Mo.

Throw Away Your Antiquated Grease Lubricated Idlers
and Install Modern Anti-Friction Equipment

B-M BELT CONVEYOR IDLER

CAST IRON OR
STEEL ROLLERS

ANTI-FRICTION

ROLLER OR
BALL BEARINGS

(PATENT PENDING)

WHY?

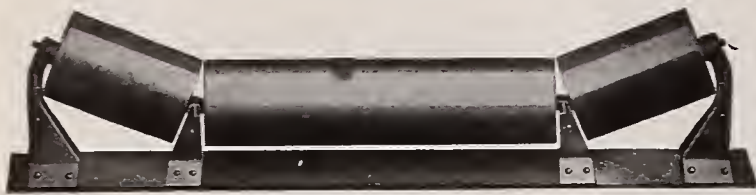

Put this unit right into your present stands

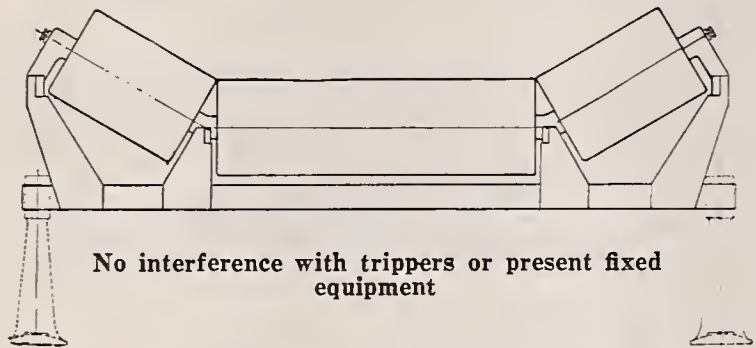

No interference with trippers or present fixed equipment

BECAUSE

Save 50% in power.

Cut cost of maintenance and lubricant expense to almost the vanishing point.

Decrease strain on and increase life of belts.

Eliminate injury to belts.

Use lighter duck and fewer plies in new belts.

REDUCE FIRE HAZARD.

Make replacements at once or gradually as suits conditions.

The saving in power, lubricants and maintenance will offset cost of installation.

AND LOOK AT THE HOUSE BEHIND THE INNOVATION!

A concern whose name has—for

75 YEARS

Been accepted as standard in specifications for high grade milling machinery and having a standing that will always be guarded and maintained.

BARNARD & LEAS MANUFACTURING CO.

MOLINE

ILLINOIS

Everything for Elevating, Conveying and Milling Equipment

HUGH P. ROBBINS

Special Sales Engineer

Old Colony Building

Chicago, Illinois



Do you know what these *leaks* cost you?

The new Randolph catalogue offers you, without cost, an easy way to determine for yourself the actual money loss in your plant due to leaks such as are illustrated in the above cut. Send for a copy of this catalogue. It is free—write today.

When you buy Randolph Driers you buy Originality—never copies
—and you are fully protected by patents.

O. W. RANDOLPH COMPANY
TOLEDO, OHIO, U. S. A.

Hess Direct Heat Driers

Have all the advantages and flexibility
of Hess Steam Heat Driers

WITHOUT

Expense and Bother of Steam Boilers

Simple to Install Simple to Operate Automatic

HESS DRIERS ARE PATENTED

WE DO NOT INFRINGE THE PATENTS
OF OTHERS. WE GUARANTEE THIS.

HESS WARMING & VENTILATING CO.

1207 South Western Avenue
CHICAGO, ILLINOIS

HESS DRIER COMPANY OF CANADA, LTD.

68 Higgins Avenue, Winnipeg, Manitoba



1,000 Bushel Hess Direct Heat
Drier and Cooler

Crowell Elevator Company
I. C. Railway Elevator, Omaha, Nebr.

LET US PLAN A GRAIN DRYING PLANT FOR YOU



Manchester Ship Canal Elevator
Manchester, England
Capacity 1,500,000 Bushels
Completed 1914



Buenos Aires Elevator Co.
Buenos Aires, Argentina
Capacity 750,000 Bushels
Completed 1920



John S. Metcalf Co.

Grain Elevator Engineers

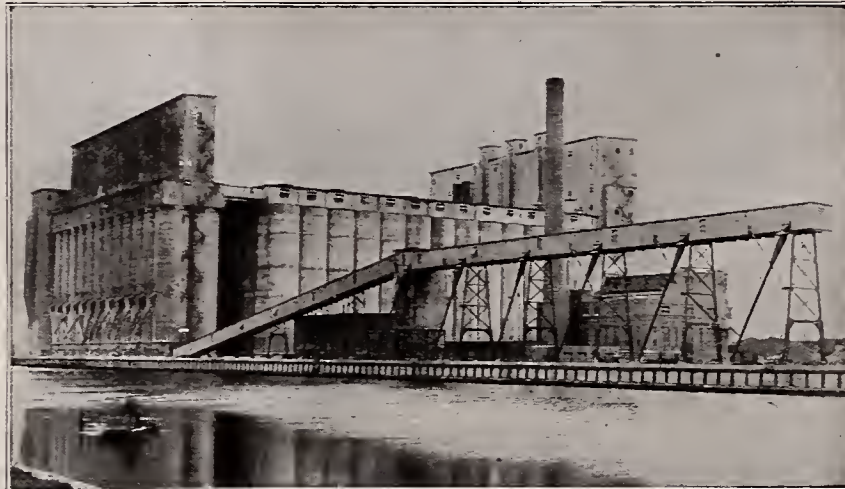

Chicago & North Western Railway Elevator
South Chicago, Illinois
Capacity 10,000,000 Bushels
Completed 1920

OFFICES:

- Chicago, Illinois - - - 111 W. Jackson Blvd.
- Montreal, Canada - - - 460 St. Helen Street
- Sydney, Australia - - - - - Pitt Street
- London, England - - - - - 17 Dartmouth
- Vancouver, B. C. - - - 837 W. Hastings St.



Harbour Commissioners Elevator No. 2
Montreal, Quebec
Capacity 2,600,000 Bushels
Completed 1912



Sydney Terminal Elevator
Sydney, Australia
Capacity 6,400,000 Bushels
Completed 1921



MONARCH

Built Elevators
Assure You
Economical Design
First Class Work
Efficient Operation
and
Satisfaction
Let Us Submit
Designs and Prices

One of the Modern Houses Which Has Made a Record
for Rapid and Economical Handling
CONCRETE CENTRAL, BUFFALO, 4,500,000 Bu.



MONARCH ENGINEERING CO. - - - BUFFALO, N. Y.



The Barnett & Record Company

GENERAL CONTRACTORS

Designers and Builders of

Grain Elevators, Flour Mills and Heavy Structures

Reinforced Concrete and Steel Ore Dock constructed at Superior, Wisconsin, for the Allouez Bay Dock Company. Entirely Fireproof.

Write for Designs and Estimates

OFFICES:

Minneapolis, Minn. Duluth, Minn. Fort William, Ontario

**MACDONALD
ENGINEERING
COMPANY**

CONSTRUCTING ENGINEERS

Designers and Builders of

**GRAIN ELEVATORS, FLOUR
MILLS, WAREHOUSES, ETC.**

We Have Specialized in

**CONSTRUCTION IN THIS FIELD FOR
MORE THAN 40 YEARS**

Sketches and Estimates Gladly Furnished

MAIN OFFICE
One La Salle Street, Chicago

NEW YORK SAN FRANCISCO TORONTO

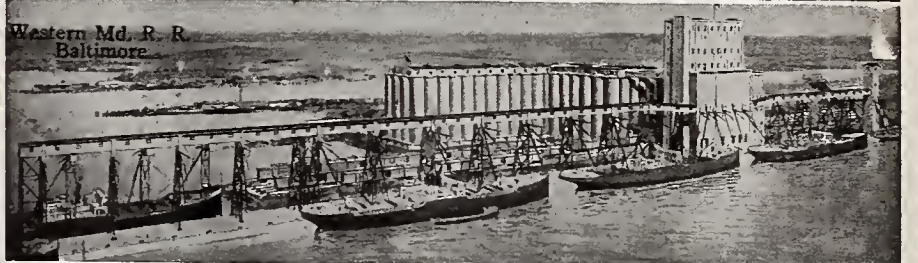
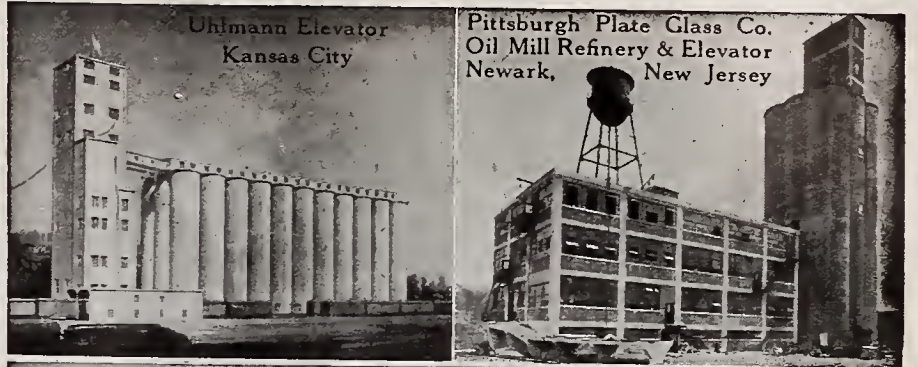

JAMES STEWART CORPORATION

W. R. SINKS, President H. G. ONSTAD, Vice Pres. and Gen. Mgr.

ENGINEERS AND CONTRACTORS

FISHER BUILDING — 343 S. DEARBORN ST.

CHICAGO, ILLINOIS

Phone Harrison 8884

THE MOST EFFICIENT GRAIN ELEVATORS IN AMERICA
ARE EQUIPPED WITH

KELLY PNEUMATIC TUBE SYSTEMS

KELLY PNEUMATIC TUBES ARE
INSTALLED IN
QUAKER OATS PLANT, ST. JOSEPH
QUAKER OATS PLANT, CEDAR
RAPIDS
ILLINOIS CENTRAL ELEVATOR,
OMAHA
A. E. STALEY, DECATUR

STANDARD AND SPECIAL TUBES
AND CARRIERS TO MEET EVERY
REQUIREMENT

EXPERIENCED ENGINEERING
SERVICE AT YOUR COMMAND

ESTIMATES PROMPTLY FURNISHED
ON CASH CARRIERS
PACKAGE CARRIERS
PNEUMATIC TUBES
LIGHT ELEVATOR AND
BELT CONVEYORS

KELLY CASH AND PACKAGE CARRIER CO.
422 NORTH WESTERN AVENUE
CHICAGO, ILL.

L. A. STINSON CO.

Engineers and General Contractors

**ELEVATORS, MILLS AND WAREHOUSES
COMPLETE**

332 So. La Salle Street Chicago, Ill.

General Overhauling and Improvements

FEGLES CONSTRUCTION CO., Ltd.

ENGINEERS -:- CONSTRUCTORS

FORT WILLIAM, ONT. MINNEAPOLIS, MINN.

*DESIGNED for the years
ahead—an advance we
propose to maintain.*



N. M. PATERSON CO.

2,500,000 Bu. Elevator

FORT WILLIAM, ONT.

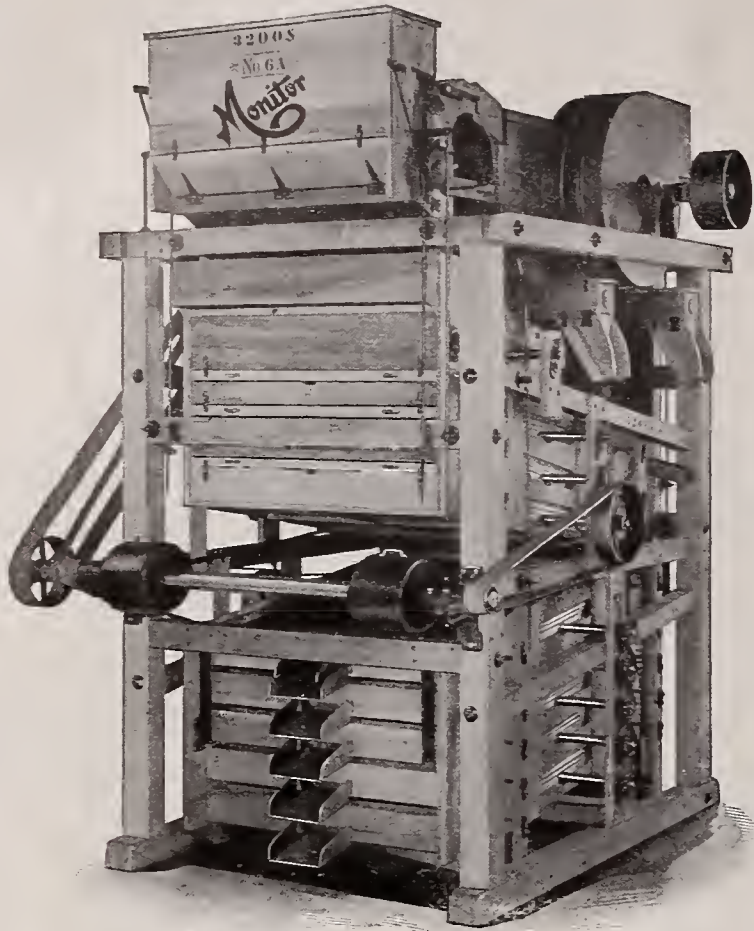

Of Considerable Value

The screenings from your grain cleaning operations are quite apt to contain items of considerable value, were they by themselves. Whole wheat, broken wheat, oats, barley, buckwheat, flax, mustard—all have a definite market value of their own and most of them are found in all screenings.

The MONITOR Screenings Separator will reclaim each of these, separately and profitably.

Ever spread out a handful of your screenings to see what is there? We suggest that you do this. It may open up a new source of considerable profit.

You Are in Business for Profit, We Take It

HUNTLEY MFG. CO.

Department E

BROCTON, N. Y.

(FORMERLY AT SILVER CREEK, N. Y.)

OUR REPRESENTATIVES, AT YOUR SERVICE

CHICAGO
A. D. McPherson, 410 Utilities Bldg.
MINNEAPOLIS
A. F. Shuler, 222 Millers & Traders
Bk. Bldg.
KANSAS CITY
F. J. Murphy, 732 Board of Trade

ROCHESTER, N. Y.
B. L. Brooks, Powers Hotel
CANADIAN PLANT
Tillsonburg, Ontario
VANCOUVER, B. C.
Will Hill, 414 Seymour St.

LOS ANGELES
Humphrey Mfg. Co.
J. J. Ross Mill Furnishing Co.
Portland, Ore.—Seattle, Wash.
DAYTON, OHIO
W. B. Sutton, 337 W. Hudson Ave.

PHILADELPHIA, PA.
C. Wilkinson, P. O. Box 147,
Lansdown, Pa.
HIGH POINT, N. C.
C. T. Burton, 529 White Oak St.
SAN FRANCISCO
John R. Gray, Inc., 726 Harrison St.

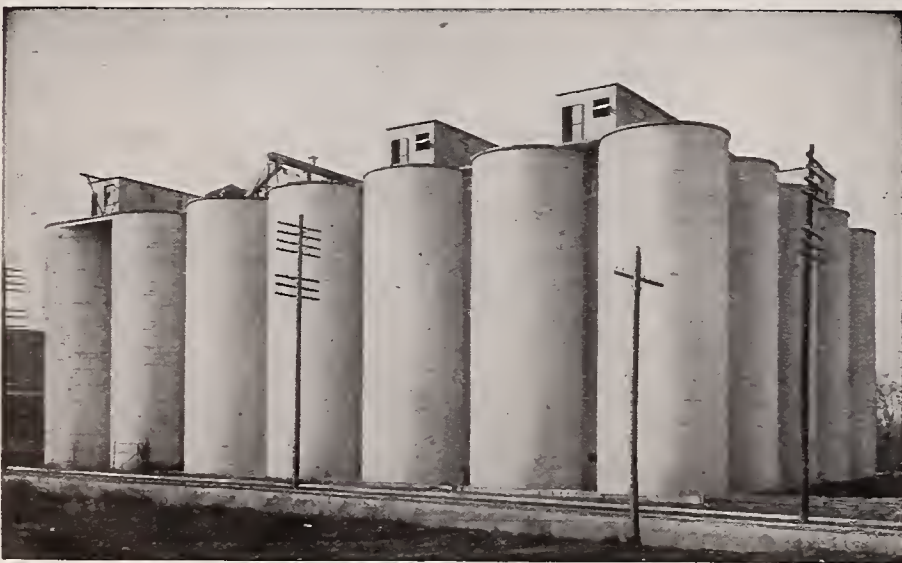

CAPACITY 800,000 BUSHELS

THOSE CONCERNED

Or even casually interested in concrete grain storages notice and usually comment on the accurate alignment, smooth walls, and clean cut appearance of

POLK SYSTEM BINS

We Design and Erect

Send us your inquiries.

POLK GENUNG POLK CO.

FORT BRANCH

INDIANA

JONES-HETTELSATER CONSTRUCTION CO.

Designers and Builders

MILL BUILDINGS :: ELEVATORS
FEED PLANTS

708-9 Mutual Building, Kansas City, Mo.

Plans and Specifications

For Elevator Construction

For Machinery Installation

For the speedy and efficient completion of your new storage project.
Money can be saved and results insured by this service of:

Horner & Wyatt

Consulting Engineers to the Milling and Grain Trade
468 Board of Trade Bldg. Kansas City, Mo.

ROSS B. WILSON

CONSULTING ENGINEER

TO

THE GRAIN ELEVATOR TRADE

332 SO. LA SALLE ST.

CHICAGO, ILL.

PHONE WEBSTER 7126

AIN'T IT THE TRUTH?

"It's easy to convince yourself that your troubles are greater than those of other people,"

and the Elevator Superintendent who is obliged to operate his elevator without the

ZELNY THERMOMETER SYSTEM

needs no further evidence of his troubles to convince anyone storing grain that he has lots of trouble, but he won't receive much sympathy from the Elevator Superintendents who have the

ZELNY THERMOMETER SYSTEM

for they don't have the same troubles and know that if the Superintendent passing out the self pity stuff would insist on having his bins equipped with the

ZELNY THERMOMETER SYSTEM

his greatest troubles would be over and his nights be restful, his days shorter and his work a pleasure. All mill and elevator owners are interested in saving money and making working conditions as easy and pleasant as possible consistent with economy, why not suggest the

ZELNY THERMOMETER SYSTEM

to your President and let him make inquiry of those who have it? He will be surprised and so will you. Our Catalogue No. 6 contains a list of users all of whom have more than one installation. If you want a catalogue or want your President to have one our address is

ZELNY THERMOMETER COMPANY

542 S. Dearborn St.
Chicago, Ill.

Two Birds With One Stone

Lacing, Mechanically Correct: Each hammer-clinched steel tooth of Alligator Steel Belt Lacing holds its width of belt in a powerful compression grip like a tiny vise.



THE great surplus of strength of this smooth hinged joint gives length and reliability of service, unexcelled, in any type of belt and practically any service.

The sectional steel hinge pin (patented) absorbs friction in the joint.



Belt End Protection

Thrown In Sealing the belt end with the powerful compression grip prevents internal friction and ply separation at the joint. Alligator Steel Belt Lacing prevents belt end troubles and increases the life of belting.

Kill two birds with one stone!

Eleven sizes. Sold throughout the world

FLEXIBLE STEEL LACING CO.
4627 Lexington Street Chicago, U. S. A.
In England at 135 Finabury Pavement, London E. C. 2



Only a
Hammer
Needed

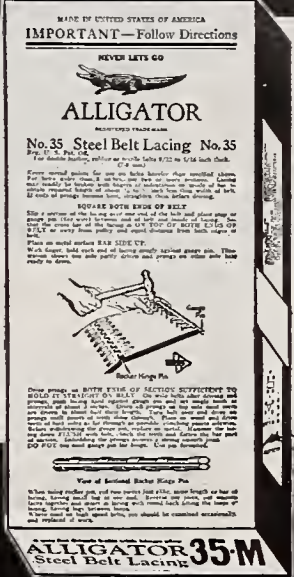

Note the Alligator Stamped on the Lacing and the Yellow Labeled Box for Your Guidance in Buying

Easy to
Install

Requires
Little
Space

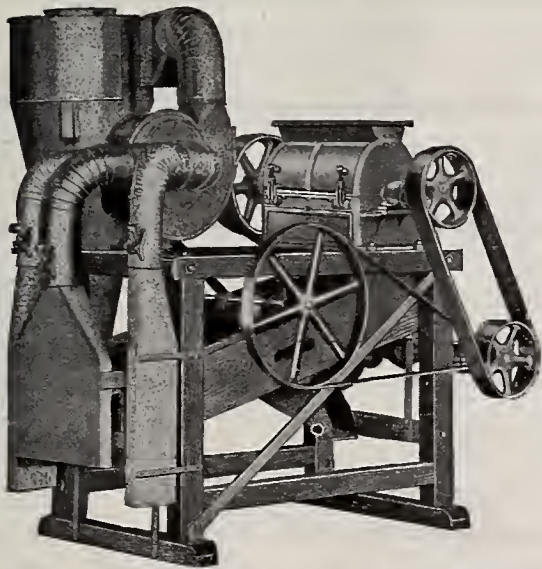

Makes Three
Distinct
Grades of
Quality Steel
Cut Corn

Produces
Small Quan-
tity of Offal

The Ball Bearing Top and Bottom Screen Monarch Corn Cracking Outfit

Five machines in one designed to produce steel cut corn (three grades) of unsurpassed quality. Equipped with Monarch Patented Top and Bottom Screen Cutter, three sieve grader aspirating legs, metal fan and dust collector. Driven by one main belt, easy to install, takes little space and requires very little power to operate.

A quality machine that makes a quality product and priced to make it a profitable investment for every mill and elevator.

Write for new booklet



Sprout, Waldron & Co.

1203 SHERMAN ST., MUNCY, PA.

THE MONARCH MILL BUILDERS

Chicago Office
9 S. Clinton St.

Kansas City Office:
612 New England Bldg.

A Perfect WORM GEAR HEAD DRIVE AT VERY REASONABLE PRICES

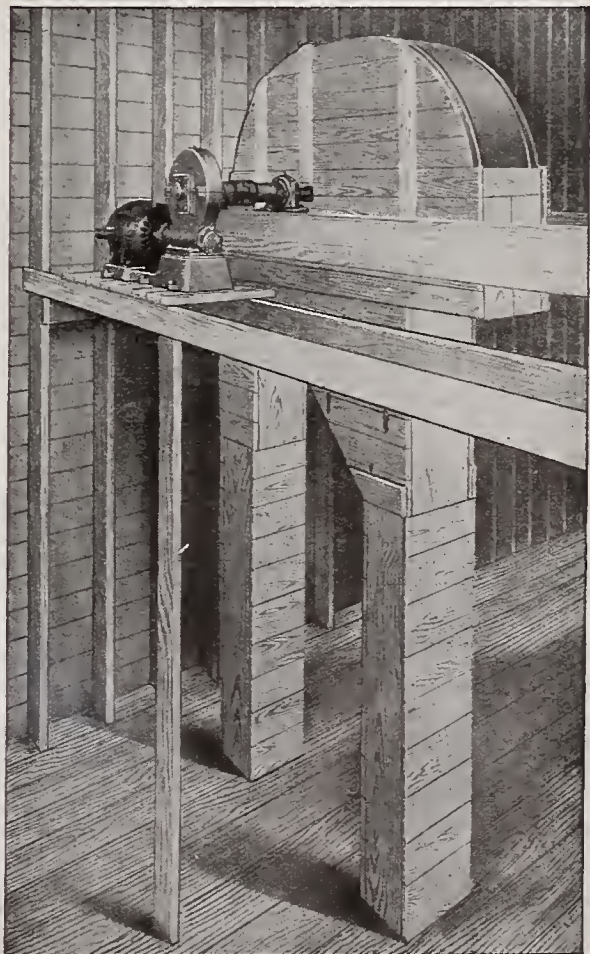

Union Iron Works, Decatur, Ill.

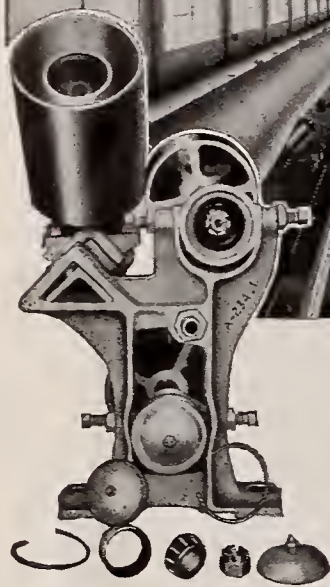

EHR SAM
TIMKEN-EQUIPPED
CONVEYOR
INSTALLATIONS

THE illustration above shows an "Ehrsam" Timken bearing-equipped conveyor—and the lower illustration shows an "Ehrsam" heavy duty self-propelling tripper—both just recently installed in an addition to a large southwestern elevator. Additional "Ehrsam" equipment was installed too. For the name "Ehrsam" stands for quality elevator equipment in the industry.

J. B. Ehrsam & Sons Mfg. Co.
ENTERPRISE, KANS.

Manufacturers of Machinery for flour mills, Cement Plaster Mills, Grain Elevators, Salt Plants, Coal Handling and Rock Crushing Systems, Fertilizer Factories, Power Transmission, Elevating and Conveying equipment.



**MORE LIGHT ON
FEED MILL PROFITS**

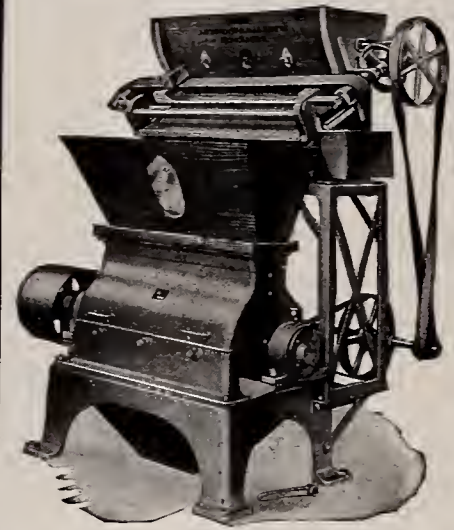

Many feed mill operators have been guided to the more profitable milling of scratch feeds through the assistance of the Wolf Rotary Cutter.

It provides maximum, clean-cut grain with minimum meal and delivers a finished product with less power in one operation.

It is inexpensive to install and highly economical in operation.

It provides true shearing action and allows for a change of knives and screens in a few minutes, not hours. It never needs adjustment.

To successfully meet present day progress and competition in the production of scratch feeds the answer is—The Wolf Rotary Cutter.

THE WOLF COMPANY

68 Commerce St., Chambersburg, Pa.

Manufacturers of a complete line of flour and feed mill machinery.

Offices and Representatives throughout the United States.

THE WOLF COMPANY, 68 Commerce Street, Chambersburg, Pa.

Please send me more information on the Wolf Rotary Cutter mentioned in your advertisement in the April 15th issue American Elevator & Grain Trade.

Name

Address

City

State

BOOKS FOR GRAIN DEALERS

MILLING KINKS, contains 169 illustrated handy devices of great value to the practical elevator operator and miller. Price...\$1.00

SHAFTING, PULLEYS AND BELTING, by Herbert E. Collins. An invaluable work for mills and elevators, or any other place where machinery is installed; well illustrated. Price\$1.50

FEEDS AND FEEDINGS, by Prof. W. A. Henry. Illustrated, 613 pages. Price\$4.00

WALLS, BINS AND GRAIN ELEVATORS, by Milo S. Ketchum. Illustrated, 556 pages. Price\$5.00

ROPP'S CALCULATOR, new and improved edition, with complete grain tables, and other invaluable discount and stock tables. Price.....\$1.00

FUMIGATION METHODS, by Prof. Willis G. Johnson. A complete practical treatise on the fumigation of elevators, mills, etc.; 313 pages; illustrated. Price...\$2.00

Any of the above sent postpaid on receipt of price

**MITCHELL BROS.
PUBLISHING CO.**
431 S. Dearborn St. Chicago, Ill.



**There Is a Good Profit in
Every Barrel of**

Semi-Solid Buttermilk

**for the DEALER who sells it
and the FEEDER who feeds it**

WIS E Dealers, Millers and Feed Grinders, both large and small, realize that is necessary to sell a product that will give their customers perfect satisfaction and still make a good profit for their business.

And Semi-Solid Buttermilk does just that—it satisfies your customers because it keeps their poultry and hogs in good health and raises production to a point that it increases their income materially and it makes you a better profit than the same money invested in most any other commodity you sell.

We Help You Sell

To make selling easier for you there is a constant stream of advertising literature, booklets, circulars, pamphlets, letters and magazine advertising going forth each month to pave the way for your selling. Also the helpful assistance rendered you by our own sales organization. Selling Semi-Solid Buttermilk increases your other sales because it helps all other hog and poultry feeds make good. It's a boon to your customers and to your business.

*Write to us today for our proposition
in your territory*

CONSOLIDATED PRODUCTS COMPANY
2400 Lake Park Ave. • Chicago



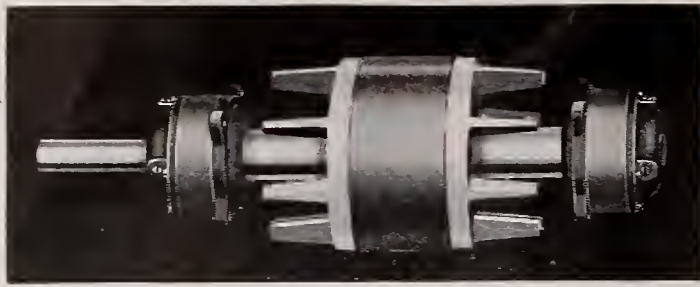

Complete rotor showing the sturdy shaft and large, completely sealed ball bearings.

This motor has sealed ball bearings!

Bearings stay clean always—Need greasing only once a year

Bearings sealed permanently against dust and dirt! No wonder Fairbanks-Morse Type QLS (line start) Motors are widely used by grain men. Dust cannot cause bearing wear and failure because bearings are protected perfectly, even when the rotor is removed. Sealed ball bearing construction keeps operating costs low and greatly increases motor life. Greasing is necessary only once a year—and then takes but a few minutes.

You get other advantages, too, when you buy Fairbanks-Morse Type QLS Motors for your drives. Because of the "line start" (across the line) construc-

tion, starting current is less than that of a standard motor of similar rating. Control is simplified, as no intermediary control device is necessary. F-M design and quality construction assure you a motor that will serve dependably and economically for years.

Write for interesting information, or let an F-M engineer explain how F-M Type QLS Motors will help you to cut operating costs.

FAIRBANKS, MORSE & CO.
900 S. Wabash Ave., Chicago
32 branches at your service throughout the United States

Self-aligning, double-row ball bearings mounted in sealed shell which excludes dust and dirt.

FAIRBANKS-MORSE MOTORS



F-M Type QLS Ball Bearing Induction Motor

EA22.24

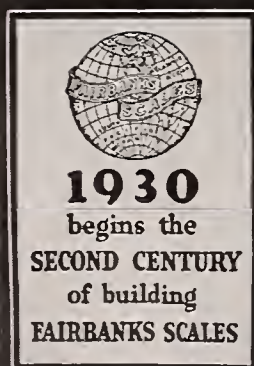

A monthly journal devoted to the elevator, grain, hay, feed and seed interests.

Official paper of the Illinois Grain Dealers Association.

Established in 1882.



Published on the fifteenth of each month by Mitchell Bros. Publishing Co., 431 So. Dearborn St., Chicago, Ill.

Subscription price, \$1.00 per year. English and Foreign subscription, \$1.75 per year.

Established in 1882.

The House That Cake Built

Igleheart Bros., Inc., Build Vincennes Elevator to Handle Cake Flour Mill Demand for Wheat

Each year the annual consumption of wheat for cake flour goes up a notch and each year progressive milling and elevator concerns are capitalizing on the increase. It is estimated that Americans eat \$1,300,000,000 worth of cake a year made from 5,500,000 barrels of flour. This means that nearly 25,000,000 bushels of wheat are used exclusively for cake production each year, a good part of which passes through the Igleheart Bros., Inc., elevators located in the midst of the Indiana wheat country.

The company's newest plant at Vincennes, designed and built by the James Stewart Corporation of Chicago, is used mainly for the handling of wheat to supply the 450-barrel Atlas Mills, one of the four mills owned by Igleheart Bros., a subsidiary of the General Food Corporation since 1926. The three other plants are at Evansville and have a combined capacity of 2,300 barrels of flour and a storage capacity of 1,350,000 bushels.

It is at the Vincennes mill that the most popular of the Igleheart Bros. cake flours, "Swans Down" made from Soft Winter wheat, is manufactured. Needing a larger storage space at Vincennes to take care of increased flour production, the company decided to erect its newest unit there, work being completed last July in time for handling the 1929 crop.

The elevator is a very compact structure with a storage capacity of 400,000 bushels and is of reinforced concrete. The storage is made up of 18 circular concrete bins, 114 feet high, with an interior diameter of 15 feet. Bins are arranged in three rows of six tanks spread longitudinally and connected with walls, thus providing interspaced bins. The complete plant consists of a trackshed for receiving by cars, truck and wagon dumps for receiving from farmers, a cleaning house, storage tanks, and a drier.

On the side facing the railroad tracks is a structural steel two-rail trackshed covered with corrugated metal which houses the car shovels, receiving pit, and car puller. Grain doors are removed from loaded cars by means of a power-driven grain

door remover and the grain is shoveled into a receiving hopper by means of an automatic power shovel. From the receiving hopper the grain is carried by a 14-inch screw conveyor to one of the lofter legs, where it is raised to a huge garner over a 2,000-bushel Fairbanks Hopper Scale, weighed and spouted to another lofter leg, and then elevated to the top of the receiving house where it is placed in cleaning bins or put directly into the storage tanks.

Below the hopper scale is a 24 by 48-inch Scalperator, arranged so that grain coming from the scale can be scalped as received, the scalped grain going

Manufacturing Company, over the driveways.

The grain is cleaned as rapidly as it is received and the screenings are spouted down and bagged on the receiving level for the farmers, thus determining the dockage of each load. The cleaned grain is dropped into 9-inch screw conveyors which deliver it to the lofter leg.

One of the receiving pits is equipped with a diverting mechanism so that when cob corn is dumped into it the corn discharges to a Western Corn Sheller, the shelled corn and cobs going into a special large sheller leg which elevates the material, discharging it to a No. 33 Western Gyration Corn Cleaner. The cleaned shelled corn is then spouted directly to one of the lofter legs.

Grain to be reclaimed from storage is drawn out of the bottom of the bins and conveyed through two 14-inch screw conveyors to a shipping or turning leg, elevated to where it can be weighed and shipped through a car spout or put back in storage. In the basement are two 6-inch screw conveyors; one to convey screenings from the screenings bin to the mill for grinding into feed and the other for taking the cleaned wheat from any of the six bins used for supplying the mill.

The dust collecting system consists of a number of units. The dust collectors for the cleaning machines are placed so that they can discharge into a screenings bin of 2,000 bushels' capacity, or in case the dust is to be returned to the farmer it can be by-passed and discharged with the screenings

as it is returned to them.

A dust trap is provided ahead of the direct connected motor-driven fan to remove all grain and coarse materials before it is discharged into the cyclone. The dust collecting and sweeper systems are operated by a 15-horsepower 1,200 r.p.m. General Electric Motor.

A 450-bushel per hour Randolph Direct Heat Grain Drier is used, being located above the driveway. It is supplied through a garner which is reached by either the receiving or lofter legs. When the grain is dried it may be spouted to the dump



IGLEHEART BROS., INC., ELEVATOR, VINCENNES, IND.

to the lofter leg. A 2,000-bushel capacity screenings bin is provided underneath the scalperator for the accumulation of screenings.

Two driveways lead into the dumper house for receiving grain from farmers, each drive having a Fairbanks 20-ton Truck Scale and a truck dump. Grain is dropped from the trucks or wagons into receiving hoppers below the driveway and spouted by gravity to elevator legs of 1,250 bushels' per hour capacity, there being one for each driveway. These legs are placed so as to discharge directly into No. 8 Monitor Grain Separators, of the Huntley

house lofter legs or to the lofter legs in the storage, where it is elevated and spouted or conveyed into the various bins for storage. The drier is complete and is equipped with automatic draught and temperature control by the Zeleny Thermometer Company of Chicago. Drier and cooler fans are driven by means of two 7½-horsepower motors through silent chain drives.

The general machinery was supplied by the Weller Manufacturing Company of Chicago.

SMUT LOSSES SERIOUS IN INTERMOUNTAIN WHEAT

By J. F. WELCH, Grain Supervisor

During the last five years there has been a continuous year-to-year increase of smutty wheat in the Hard Red Winter wheat crops of the intermountain region.

According to the records of the Ogden (Utah) Grain Exchange inspection department for the crop years beginning with 1925-26 when 46.8 per cent of the receipts of Hard Red Winter were graded smutty, this condition has increased from year to year as follows: 49.7 per cent in 1926-27, 54.8 per cent in 1927-28, 56.0 per cent in 1928-29, and then jumped to the unprecedented high figure of 78.5 per cent during the first six months of the 1929-30 season.

This latter percentage of smutty wheat has never been nearly approached in a Hard Winter wheat crop in any part of the country as far back as the records of Federal Grain Supervision go, and has only been exceeded twice which was in the Soft Red Winter wheat crops of the Pacific Northwest for the seasons of 1924-25 and 1926-27.

The highest percentages of smutty Hard Red Winter wheat ever reached in the other winter wheat regions of the country during this five year period were 39.8 per cent of the receipts at Omaha during 1925-26, 22.2 per cent at Kansas City in 1926-27, and 42.5 per cent of this class of wheat at Portland, Ore., during 1924-25. Furthermore, the intermountain country is the only producing area that shows a steady increase of smut infection in this kind of wheat. The receipts of smutty Hard Red Winter wheat at Kansas City and Omaha both show decreasing tendencies during this five year period, and the Portland receipts show a very substantial decline from the high point of 41.5 per cent in 1925-26 down to only 11.9 per cent in 1928-29.

Just what conditions, climatic or otherwise, there may be that are causing this smut contamination to grow steadily worse each succeeding year in spite of reported widespread seed treatment, has been made the subject of considerable inquiry on our part from those on the ground and in close touch with the situation.

Our inquiries, mostly addressed to county agents of the Hard Red Winter wheat producing sections of southern Idaho and northern Utah, brought many and varied possible causes. All of them informed us that seed treatment has been extensively practiced in their respective communities during most of these five years and particularly so during the last two or three years. It is quite evident, however, that the methods of treatment have been inadequate in some form or another.

The principal inadequacy of this apparent ineffective treatment seems to be, in the opinion of many persons, the use of low grade copper carbonate. We are informed that much 18 per cent copper has been used during these years without very satisfactory results in most of the localities reporting. This factor, together with the frequent use of an insufficient amount of dust to each bushel of seed, and the further use, in some cases, of heavily smutted wheat for seed purposes, is blamed by many for failure to arrest the progress of this increasing smut infection. Several county agents report that steps have been taken to introduce a better grade of copper carbonate into this region, that is, about a 50 per cent metallic copper and that much better results are expected through the use of this higher grade material.

Another cause advanced by some is the increasing

use of combine harvesters. It is contended that these machines more generally distribute the spores over the land than does a stationary thresher, and that through the harvesting season being more prolonged because the farmers are using combines for as large an acreage as possible, the smut showers are continued throughout several months in the fall. This is thought to contaminate the soil badly.

One loss that is incomputable but, nevertheless, very real, is the effect that smut has on the weight per bushel of wheat. Smutty wheat is lighter test weight than wheat of similar plumpness which is not smutty so this represents a very serious loss, though one that cannot accurately be computed into dollars and cents.

A PERISCOPE FOR CORN

Fred G. Smith, chairman of the educational committee at the Chicago headquarters of the Federal Grain Inspection service, reports that several licensed inspectors are finding the Sioux City type corn tester a great aid in determining the "total damaged" factor. Supervisor Wright and Inspector Larson, of the Sioux City (Iowa) Grain Exchange, are credited with the development of this time saver.

The setup, as shown here, consists of a tray or board 18 inches square with a 4 by 12-inch opening cut in the center.

Into this aperture is fitted a piece of plate glass

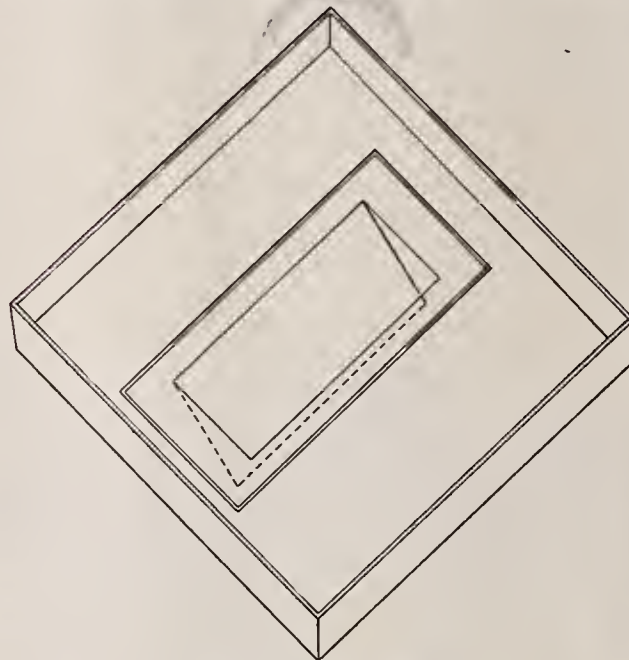

DAMAGED CORN TESTER

mirror in such a way that one of the long edges is flush with the top or surface of the board, and the opposite edge flush with the bottom or back of the board. A piece of beaver board 18 inches square is tacked to the bottom or back of the board. On the top or surface of the board is nailed a piece of ¾-inch, three-ply panel board 18 inches square with a hole cut in the center 6 by 14 inches, into which is fitted a piece of ¾-inch plate glass. A strip or moulding is put around the edges of the board or tray projecting above the surface of the board ¾-inch on the back and two sides and flush with the surface on the front.

A portion of corn (250 grams) is placed on the tray in the space back of the glass. Then, by sliding 25 or 30 kernels at a time over the glass, the damaged kernels can be easily determined by the reflection of the under side of the kernel in the mirror glass below.

DESERT GRAIN FOR DROUGHT-STRICKEN CHINA

A dispatch from Peiping, China, to the *Christian Science Monitor* daily, discloses that seed which will yield wheat in the arid regions of China and so serve to prevent famine was recently explained to the Peiping Rotary Club by L. M. Outerbridge, who has completed interesting agricultural experiments at Fenchow in Shensi Province.

The purpose of the experiments was to find a

seed suitable to the Shensi and Kansu provinces, where drought has been a plague for centuries. For several reasons it has been impracticable to undertake artificial irrigation in these regions, and many crop failures have been reported due to delayed rain.

Mr. Outerbridge showed by means of photographs that the new drought-resisting seed produces bountiful crops where the old native grain succumbs.

All experiments were carried out in ways feasible for the peasants to imitate, and for this reason the use of foreign machinery was ruled out.

The new seed grain, which was selected for its deep root and thick leaves, has the ability to wait for late rains without withering. Careful research into soil conditions and experimentation with many seeds were required before this particular plant was selected for this territory.

Samples of seeds from many parts of the world were tested to discover grain suitable for the arid conditions. Last year co-operative tests were conducted on more than 100 farms and the result showed that certain drought-resistant seeds, sown side by side with the local seed, produced bountiful crops, which in some cases exceeded four times that of the customary seed.

Mr. Outerbridge explained that \$40,000 donated for the relief of the famine victims would feed only 7,000 people for one month, whereas the same sum of money invested in the new seed would plant 12,000 acres, thus producing sufficient grain to feed 25,000 people for one year.

PLAN SUMMER CROP MEETS

Co-operative extension administrators and specialists in agricultural economics will for the first time hold regional meetings to develop more effective and practical methods for putting into the hands of farmers information relative to the agricultural outlook, C. B. Smith, chief of the office of co-operative extension work, United States Department of Agriculture, announced May 8.

State representatives attending the annual agricultural outlook conference held at the Federal Department of Agriculture last January proposed the plan for these regional meetings. They expressed the opinion that regional conferences will facilitate the development of outlook information related more closely to the problems of the regions and that this will enable co-operative extension workers to be more helpful in developing a program for adjustment of agricultural enterprises.

The Western States Regional Extension Conference, which will meet at Bozeman, Mont., the week of August 11, has provided for discussions of outlook material and plans. A central states meeting is scheduled for September 25, 26 and 27, at Ames, Iowa. Arrangements for a meeting in the cotton states of the South and Southwest are not yet completed. The northeastern conference will immediately follow the annual national outlook conference.

McCALL, CEREALIST, PROMOTED

Max A. McCall, for the last six years assistant head of the office of cereal crops and diseases in the Bureau of Plant Industry, United States Department of Agriculture, has been named principal agronomist, in charge of this office, according to an announcement by Dr. W. A. Taylor, chief of the bureau. Mr. McCall has been acting in charge of the office for the last three months.

"Both as an investigator and as an administrator, Mr. McCall has demonstrated exceptional ability," Dr. Taylor said. "His training and his years of experience in agricultural research and administration constitute a solid background for the work he will direct. His ability to co-operate effectively with other workers and to inspire his associates to a high degree of efficiency, and the success which he has attained in all his lines of endeavor, have been noteworthy."

Mr. McCall was born in Kansas in 1888.

New Orleans . . Funnel for the Grain Surplus

The announcement this month by the United States Grain Stabilization Corporation that it has disposed of all its cash wheat holdings at the seaboard and Gulf, reflects one of the good uses to which the grain handling facilities of the Pelican State's chief port are being put. The factors which enable New Orleans to be a rapid relay station for grain are discussed here.

THERE are a lot of big things—and a lot of little things—in and around New Orleans, La., to interest the grain trader. The big things, including five elevators with a combined storage capacity close to 6,000,000 bushels, have received wide publicity in the past, and before any review of current developments concerning them, it may be in order to glance at a few of the interesting details.

One of the most useful and unadvertised details of the Gulf grain trade is the Pelican grain trier, illustrated on this page. It was developed in New Orleans to meet a demand peculiar to the type of trade which involves ship and barge loading. By means of a long canvas shoe on one end of the trier, a cross-section of grain that is moving through a spout can be secured with a minimum of time and trouble. Incidentally, the photograph reproduced here was taken by Fred G. Smith, chair-

for example, at a single unit of the New Orleans port—the public elevator. Four shipping legs there have a combined capacity of 100,000 bushels per hour; two receiving legs, 25,000 bushels per hour each; one utility leg, 10,000 bushels per hour; and a marine leg of 18,000 capacity.

The four conveyor gallery belts can carry 100,000 bushels per hour, and 13 other belts have a combined carriage rating of 670,000 bushels per hour. Eight unloading sinks can hold 16,000 bushels—and in conjunction there are seven 2,000-bushel Fair-

Elevator is a modern sacking plant also served by the public belt railroad. It has a bin capacity of 20,000 bushels and a sacking capacity of 7,200 bushels an hour. In addition to the marine leg at this plant, the board also owns and operates a marine leg of the same capacity at the Stuyvesant docks, where two export elevators of 1,000,000 and 1,500,000 bushels capacity are leased from the Illinois Central Railroad and operated by the board



SAMPLING EUROPE-BOUND GRAIN WITH A PELICAN GRAIN TRIER

of port commissioners. These elevators likewise are equipped for complete and efficient services and are operated as public utilities, on equal basis for all users. There are seven loading berths here, so that the board actually operates 10 grain loading berths. The two marine legs are the only facilities of that character at any port of the Gulf of Mexico.

The New Orleans Public Grain Elevator, owned and operated by the port commission, has a storage capacity of 2,622,000 bushels, and is a facility open to railroads and shippers on equal terms to all. It is one of the most completely equipped grain terminals in the United States, with an enviable reputation for efficiency and cleanliness.

This plant is served by a creosoted timber wharf 2,090 feet long, offering five berths for shipping—one for the discharge of barges or ocean vessels at the marine leg, one for loading at the sacking plant, and three for loading under the spouts. The



SUCTION LEG DRAWING GRAIN FROM BARGE TO NEW ORLEANS ELEVATOR BINS

man of the educational committee of the Federal Grain Supervision headquarters, Chicago, during his recent trip to the Louisiana port. Another of his pictures gives a close-range view of a suction leg at work hoisting grain from the hold of a river barge.

In these days of exportable grain surpluses, ports such as New Orleans are in a unique position. The worse the situation is, the more the grain there is over and above domestic requirements, the more business is turned their way. One of the catches in the proposition though, is the fact that handling charges at the ports can so add to the cost of the grain that sales at the low prices offered by foreign buyers may be unprofitable.

Every transfer operation at seaboard must be executed with efficiency if the grain is to be funnelled abroad at a profit. To meet this situation, New Orleans elevators have been equipped to store, process and handle grain speedily and cheaply.

Consider the apparatus and generous capacity,



JOE HELWICK, VETERAN GRAIN INSPECTOR OF NEW ORLEANS, LA.

banks Hopper Scales. The drying units have a capacity of 4,400 bushels per hour and have been put to good use in the past season. Conditioning equipment includes two Monitor Oats Clippers of 1,500-bushel capacity each, a 3,500-bushel Monitor Separator, and eight disc separators. Grain temperature is under constant check by means of the Zeleny Thermometer System. Automatic sacking scales are in the elevator and on the elevator



PARTIAL VIEW OF THE NEW ORLEANS WATERFRONT SHOWING I. C. ELEVATORS AND SECTION OF DOCKSIDE CONVEYOR GALLERY

wharf. A modern laboratory, fully equipped for grading grain according to the official grain standards, is convenient for use of Grain Inspectors and Federal Supervisors.

Electric power is used for the entire operation of the plant and each unit is operated independently. In addition, the plant is equipped with the journal alarm system, rope strand signal system, and telephones, throughout plant and pneumatic tube from unloading shed to scale floor and foreman's office.

Operated in conjunction with the Public Grain

elevator itself is of reinforced concrete and absolutely fire-proof. A complete dust collecting system, supplemented by compressed air, makes dust accumulation impossible.

All weighing is done by licensed weighers and warehouse receipts issued by the elevator are based on those weights. Grain is inspected always before it is received into elevators, and again before delivery is made.

Unloading capacity of this elevator is 200,000 bushels a day from railroad cars, and 80,000 a day from barges or steamships. Loading into ships or

barges is performed at the rate of 100,000 bushels an hour.

Some idea of the large scale operations at this plant is given by these annual budget items: Elec-



INTERIOR OF GRAIN INSPECTION HEADQUARTERS
AT NEW ORLEANS

tricity, over \$30,000; fire prevention, \$8,000; insurance, \$7,000; machinery repair, etc., \$25,000.

In the last fiscal year, the New Orleans public elevator derived total earnings of \$401,622. Storage charges netted \$112,992; sacking \$29,000; drying \$34,000; cleaning \$2,650; loading \$3,930; elevator \$211,982; stenciling \$812; scouring \$66; miscellaneous handling (grain doors, etc.) \$5,400.

While scouring revenue amounted to less than \$100 in the last fiscal year, during the previous 12 months, revenue from that source was \$3,390.

NAT C. MURRAY TELLS HOW HE DOES IT

Among the best-known crop reporters of this and all other countries, Nat C. Murray, statistician for Clement, Curtis & Co., Chicago, holds a high place. The following statement by him as to how crop estimates are made, is of interest.

"Crop condition figures relate only to prospective yield per acre, and not to total production, which is the yield per acre multiplied by the acreage. A low condition with a large acreage may forecast as much production as a high condition with a small acreage. For this reason total quantity forecasts are more important than condition estimates alone.

"In considering the wheat crop, the yield per acre is dependent upon three factors: First, stand or number of stems or stalks to a given area; second, the size of the heads on the stalks, or rather, number of grains per stalk; and third, the size of the grains or berries. Everything which affects the final outcome of the crop does so through its influence on one or more of these factors. Early condition reports made soon after planting relate only to stand, or density of stalks or stems; as the season advances condition reports more and more take into consideration the probable development of heads, as well as to the stand; other things being equal, a strong vigorous stem in its early stages of development indicates large heads, and vice versa. The size of the kernels, whether plump or shrivelled, is an important factor in the yield per acre, but can not be reflected in condition estimates until after the season is well along. In 1926 the

July 1 Government forecast of Winter wheat was 568,000,000 bushels, and the August 1 estimate was 626,000,000, the increase being due mostly to ideal filling conditions in the last month toward maturity. This, of course, was exceptional.

"Variation in weather conditions is by far the most important cause of variation in yield per acre from year to year. Government crop reporters have estimated that over a series of years deficient moisture is the cause of more loss from a normal yield of wheat, than any other cause of loss. Taking the United States as a whole, and including both winter and spring wheat, the causes of depreciation from a normal yield, and their percentage of total loss, in the order of their importance, is as follows: Deficient moisture 40.7 per cent; plant diseases 13.1 per cent; frost or freeze 11.8 per cent; insect pests 8.4 per cent; excessive moisture 7.8 per cent; hot winds 7.1 per cent; hail 3.8 per cent; all other causes 7.3 per cent; total 100.0 per cent.

"A high moisture content in the soil during the early growth causes a relatively large number of spikelets per head, and a high water content at time of heading increases the number of developed blossoms per spikelet.

"It has been shown that wheat takes up the greater portion of its food in the early stages of growth, stores it up, and draws upon it later for the development of the grain.

"The chief plant or fungus diseases which affect the yield of wheat are rust, scab and smut. Of these black rust is most destructive, but mostly on spring wheat. The chief insect enemies of wheat are hessian fly and chinch bug. Both of these insects thrive best in dry weather."

Elevator Accounting

Saving Dollars by Reducing the Number of
Errors From Inaccurate Bookkeeping
to a Minimum

By HAROLD HEDGES

Assistant Professor, University of Nebraska

AN ADEQUATE accounting system is an important factor in influencing the success of a business organization. I do not wish to over-emphasize it nor do I wish to under-rate its importance. It is not a substitute for management, but it can be made a very valuable aid to management. The mere keeping of the records is not the all-important thing; it is the use made of the records that really counts. I have heard it said that there are two types of farmers keeping records on their farm business. There are in the one group those who think the prime essential is to get down in their records every single transaction. They have a beautiful set of books but that is as far as it goes. In the other group are farmers who keep what records they feel will meet their needs, analyze them and make use of the conclusions in conducting their farm business. The farmers in the first group are bookkeepers, pure and simple; those in the second group are business men.

I am not going to attempt to describe the bookkeeping forms or the details of an accounting system that a grain elevator organization should have. I believe it will be of greater interest if I dwell on essentials in accounting and discuss why an organization should have such records.

One essential in accounting, regardless of the type or form of the records, is accuracy. A certain business service in its regular publication attempted to impress (and successfully, too) the necessity of accuracy in the business world and I quote from their concise statement: "Recognizing the fact that 'to err is human' by no means saves us from the necessity of bearing the consequences of our errors. In every business, errors of various sorts are constantly being made. If any man asserts that he never makes mistakes, we should consider that such a statement furnishes better ground for

distrusting his veracity than for trusting his judgment.

"But errors are costly. Not only was valuable time wasted in committing the error, but usually much more of the same must be spent undoing it and doing it right. An error that escapes detection and goes out, may cost a heavy loss in time, money, reputation and good will. Goods may come back, must be repaired or replaced. Not only is labor and material wasted, but there is the trouble and expense of the accompanying correspondence, and, in spite of all efforts, a more or less dissatisfied customer at the end. Examples may be multiplied, but the wastefulness of errors is inescapable.

"Accuracy is cheap at almost any price. It is probably cheaper to check things over several times than it is to pay the penalty that mistakes exact. Modern efficiency with high-price labor demands speed, but in any work in which the human element is important, speed comes too high if purchased at the expense of accuracy. In attaining efficiency, the reduction of error is often as important as the reduction of motions.

"A subtle form of inaccuracy that is especially tempting consists of loose and indefinite statements. They appear to avoid positive misstatements. At best, such statements are valueless; at worst, they create misunderstandings and cause confusion. It is cheaper in the end to wait until definite information can be supplied.

"...Let us bend our efforts to effect a saving by reducing the waste and loss that result from oversights, blunders and errors. Definitely, when the next error occurs, you will find it well worth while to run it down, find the cause, and take measures to prevent that sort of mistake from occurring again."

Accuracy pays in dollars and cents. I have a

specific instance in mind of an organization under the manager who did not appreciate the importance of accuracy and good records. An audit of the books revealed a total of nearly \$200 in minor errors (losses to the association) due to carelessness in figuring the value of products received from patrons. Patrons were constantly dropping in to have errors corrected. A change in management and the hiring of a manager who appreciated the importance of accurate records resulted in a decided reversal in practice, and errors were few, indeed.

The accounting problem is a serious one in the small elevator. Often it is left to the manager to find time from other duties to handle the books. If a bookkeeper is employed, he is usually inexperienced and has no technical training. The large elevator organization ordinarily has the means to employ experienced help—an accounting staff familiar with the methods of internal controls and checks to avoid errors.

A second essential is that the accounting system be adequate—sufficient for the needs of the organization. Is it enough simply to know what the profit and loss is for the year? It is important to know whether charges for services rendered have been sufficient to cover costs of the services. However, more can be, and usually is, expected of the accounting system. For one thing, it furnishes the data from which the history of the organization may be written. Comparisons of each year's records with those of previous years should give some inkling of the points of strength and weakness in the business and the progress if any that has been made.

It is usually sufficient in many types of organizations if records of values alone are kept. In an elevator, I feel it is very important that accounts be kept on a quantity basis as well as in terms of value—in dollars and cents. Since handling operations make up a large part of the elevator business, records of the quantities of commodities handled is important to find out how well the job is done.

Differences in the general type of the organization call for differences in the accounting methods. In a co-operative organized on the patronage dividend plan, the need for more adequate records than those of a private concern is apparent. The volume of each member's business is the basis for the distribution of savings so it is necessary to have some

system for recording each member's transactions with the association. The books of the co-operative business should be adequate to permit a complete financial report at specified periods, usually annually, to the membership. A concise, yet complete, report that is understandable to one not versed in accounting practices, goes a long way in maintaining the confidence of the membership.

Questions are bound to arise occasionally between individual patrons and the manager over certain transactions. The manager who can turn to his records, refer directly to the patron's account and get the details of the transaction from the entry that has been made is not going to raise any doubts in the mind of that patron about questionable procedure. Instead, the correction can be quickly made, doubts removed and a satisfied customer will walk out of the office.

I have already made the point that managers can make valuable use of the records of their organizations to locate points of strength and weakness in their business methods. This question may suggest itself to the manager, "How does my business compare with those of others engaged in the same nature? Perhaps a comparison of my records with those of others engaged in the same business

would give me light on where I could make improvements." Such comparisons can be made only when there is uniformity in the accounting records, or when business organizations have an association which can care for matters of mutual concern, or when outside research agencies, such as the college of agriculture, make studies.

One more point I want to discuss briefly is the matter of the outside audit. The by-laws of most co-operatives call for a regular audit of the records of the organization. Some managers resent the examination of their records by outside auditors, but the majority welcome the audit as a means of verifying the accuracy of their accounts and welcome the auditors as a source of valuable suggestions on points of strength and weakness in their business. Auditors, as a rule, have contact with many concerns engaged in the same business, and with other concerns as well. Consequently, they are in a position to determine the methods and practices that get the best results.

The modern auditing service feels a responsibility beyond checking the accounts of an organization and preparing financial and operating statements on the business. They feel it their duty to point out to managers and officers any points

of weakness and make suggestions to remove the source of weakness. Furthermore, they consider it part of their duty to suggest those things which they have learned from other organizations that may be of value to their client.

A number of associations of co-operatives and other business organizations maintain auditing services that have done and are doing effective work but all their possibilities have not been realized by any means. They have been responsible for the introduction of better records in many a concern. They have served to bring down the cost of auditing service to all concerns. Their auditors, by reasons of their contacts, have been able to make many valuable suggestions on business methods and practices. Such auditing service may appear costly to the management of an elevator but there are many intangible benefits resulting which may be hard to measure but nevertheless are of inestimable value to the organization.

I have by no means exhausted this subject of accounting methods in this brief discussion, but I hope I have called to your attention the need and the value of an accurate, adequate accounting system supplemented by a thorough and regular audit service.

Giving the Elevator Its ♦ ♦ Annual Spring Cleaning

By C. W. GUSTAFSON
Mutual Fire Prevention Bureau

THE grain elevator is a type of plant which is called upon to carry on the larger part of its year's operations during a comparatively short period. During this period when threshing is at its height and the farmers are busy hauling grain to the elevators, often from dawn until long after dark, the elevator machinery is being operated at top speed. There is little time to do much repairing or overhauling beyond that which is absolutely necessary to maintain operations. Consequently, every elevator owner should give his house a thorough overhauling before the coming grain season arrives, in order to avoid shutdowns for repairs when there is a long line of wagons and trucks waiting at his plant to be dumped.

Important as is the proper overhauling and repairing of inside machinery and equipment, the outside premises should not be neglected. An elevator whose yard is littered with car-lining paper, old lumber, dried weeds, and with car doors thrown about indiscriminately presents anything but an inviting sight. Such a house advertises a certain shiftlessness on the part of the owner and the farmer may decide that he can expect the same shiftlessness in the business methods of the manager with the result that his business is likely to go to a more progressive competitor.

Let us point out just a few of the matters which should have the consideration and attention of every elevator owner within the next few weeks so that the elevator will be prepared to take care of the trade efficiently.

In this work, the matter of prevention of possible sources of fire should not be overlooked. It is a fact that the things which go toward the improvement of efficiency and cutting of operating costs usually tend to reduce fire hazards. So, in this program of spring repairing and overhauling, the matters of efficiency in operation and prevention of fire go hand in hand.

Let us look at the outside premises. Weeds, particularly when dried, represent a serious fire hazard through their easy ignition by locomotive sparks and careless smokers. Therefore, all weeds should be cut and hoed out and further growth retarded by use of a solution of common salt. Gather up all refuse such as paper, old lumber, and similar materials which usually accumulate during the winter season and burn them at a safe distance

from the elevator and other buildings. In this work do not forget to clean up under and about the driveway approach. Pile car doors in neat piles at a distance of at least 10 feet from the elevator. Fill in any holes in roadways leading to the elevator with gravel. For remember, a poor roadway on the elevator premises loses trade. This is important because an inviting exterior is an advertisement in itself and nothing is more inviting than a good driveway flanked by a clean yard.

While we are on the outside of the house, let us

it off and expose the cribbing to the weather. Look the roofs over, repairing any leaks that are found and renailling where necessary. As a definite fire prevention move, the owners of shingle-roofed houses should replace shingle roofs with roofs of metal or approved composition. By doing so, a very appreciable saving is made in the fire insurance rate which soon absorbs the cost of making the improvement. If the elevator has wooden siding, a further improvement can be made by covering the house with a good grade of metal, not forgetting the eaves, windows, door frames and sills where locomotive sparks are prone to lodge. This also earns a credit in the insurance rate which goes a long way toward paying for the work.

No up-and-coming elevator owner can afford to operate an elevator which is not protected against lightning. Lightning is one of the most active hazards in connection with elevator properties for the elevator usually stands out as the highest



AN ATTRACTIVE EXTERIOR MEANS INCREASED SALES

look the foundation over carefully. A weak foundation causes undue settling of the house with resultant misalignment of shafting and machine drives. Therefore, it is important that foundations be repaired if found to be defective. If the foundation is of the open type, board and iron clad it up to the ground, or at least screen it, using a heavy screen on a substantial frame. An open foundation invites accumulations of refuse of an easily ignitable nature as well as providing access to convenient lodgings for tramps.

If the siding of the elevator is found to be loose, renaill it before the spring and summer winds blow

building or object in its neighborhood, thus presenting an admirable target for destructive lightning discharges. The installation of lightning protection is now relatively inexpensive. If the house is completely iron clad and has a metal roof, effective protection can be secured by grounding the corners in the proper manner. If the house has wooden sides or a composition or shingle roof a standard lightning rod installation is needed. Your mutual insurance office will gladly supply you with complete specifications for this work and will furnish you with the names and addresses of lightning rod installers operating in your territory. If

your elevator is not yet protected, get in touch with your mutual insurance office immediately and arrange to have the work done at once.

Now let us enter the elevator and make a general inspection. We usually find that while casual housekeeping has been maintained during the winter months, a good cleaning is needed. Remove all worthless sacks and burlap, accumulations of junk, get rid of sacks of screenings which take up valuable room, and arrange the good sacks in neat piles. Now give the house a good cleaning from top to bottom with particular attention to out-of-the-way corners, on beams and ledges and similar places not generally reached.

Bearings should be thoroughly cleaned and inspected. If found to be worn excessively, rebabbit them. Clean out oil holes and wells and fill with a good grade of oil. Supply dust caps where necessary. Fortunately those who were foresighted enough to replace the plain babbited bearings with dust-tight, self-aligning ball or roller bearings need have little concern for bearing hazards as they need only supply such bearings with grease about two or three times each year. Such anti-friction bearings also effect a very appreciable saving in power due to the marked reduction in friction load, as well as eliminating the hot bearing hazard which so often necessitates the shutting down of machinery when the elevator is busiest. During overhaul-

him to give the entire installation a careful inspection and do whatever is necessary to place the equipment in proper condition. This usually necessitates complete cleaning of all open type motors, the checking of air gaps on plain bearing motors, the inspection of bearings, and a complete inspection of the wiring and control and protective devices such as fuses and overload relays. If the wiring is old and of the obsolete open type, rewire in rigid iron conduit and replace all obsolete control devices with the new efficient and convenient types. Consider replacing the old open motors with the new totally-enclosed dust tight motors, at least when replacements of old or when new motors are purchased. Your mutual insurance office will supply complete specifications for changes in existing installations or for new installations free of charge upon receipt of the necessary information. It is important that you avail yourself of this service when any changes are contemplated in order that the work be done correctly and in such a manner that you may have the benefit of a lower fire insurance rate through improvements made.

If gasoline, kerosene, or oil engine power is used, there are several points which should not be neglected. The first pertains to the location of the engine. Engines of these types are hazardous and should not be located in the elevator proper. A fire resistive power house is the best solution,

and resulting fires and explosions. Be sure fuses are of proper size and not plugged or bridged.

There is no better time than this to make a careful inspection of all fire extinguishing equipment. It is during the busy period, when machinery is being operated at capacity and when there are likely to be many visitors, that there is particular danger from fires. The old reliable water barrel and buckets have proved their worth in so many cases that they have established their position as the most valuable fire extinguishing agent in country elevators. Therefore, see that there are an adequate number of barrels in good condition, that all barrels are filled with a solution of calcium chloride, and that there are at least two good buckets at each barrel ready for use. Chemical extinguishers should be tested and filled with the proper liquid if necessary. Carbon tetra chloride extinguishers of the hand pump type are very valuable in an elevator, particularly for use on electrical equipment, and in engine rooms for oil fires, and what is very important, in driveways for use in extinguishing possible fires originating in auto trucks.

Post "No Smoking" signs in prominent places as a means toward prevention of fires caused by careless smokers. Your mutual insurance office will supply suitable signs free of charge upon request. They will also supply signs calling attention to the necessity for shutting off the motors of trucks while dumping grain. This is an important precaution as ignition of spilled gasoline by hot exhausts or back-fire is not uncommon.

To help the grain industry reduce fire hazards and improve general operating conditions, the mutual fire insurance companies maintain engineering service departments whose services are obtainable without charge. Numerous publications on a wide diversity of subjects treating on construction and installation are available from your mutual insurance office. These include the electrical code, giving complete regulations for the installation of electrical equipment, regulations for the installation and operation of internal combustion engines, a treatise on anti-friction bearings, a discussion of dust disposal containing suggested designs of dust houses with illustrations, construction of cob burners with illustrations, the construction and operation of filling stations, regulations for the installation of lightning protection, regulations for the installation of grinders, regulations for the installation and operation of air compressors, and many others.

When overhauling your elevator, or in building an addition or a new house, write your insurance office and tell them of your plans. Often it is possible for them to make suggestions which will result in more efficient and safe operation, as well as saving you many dollars in insurance premiums.

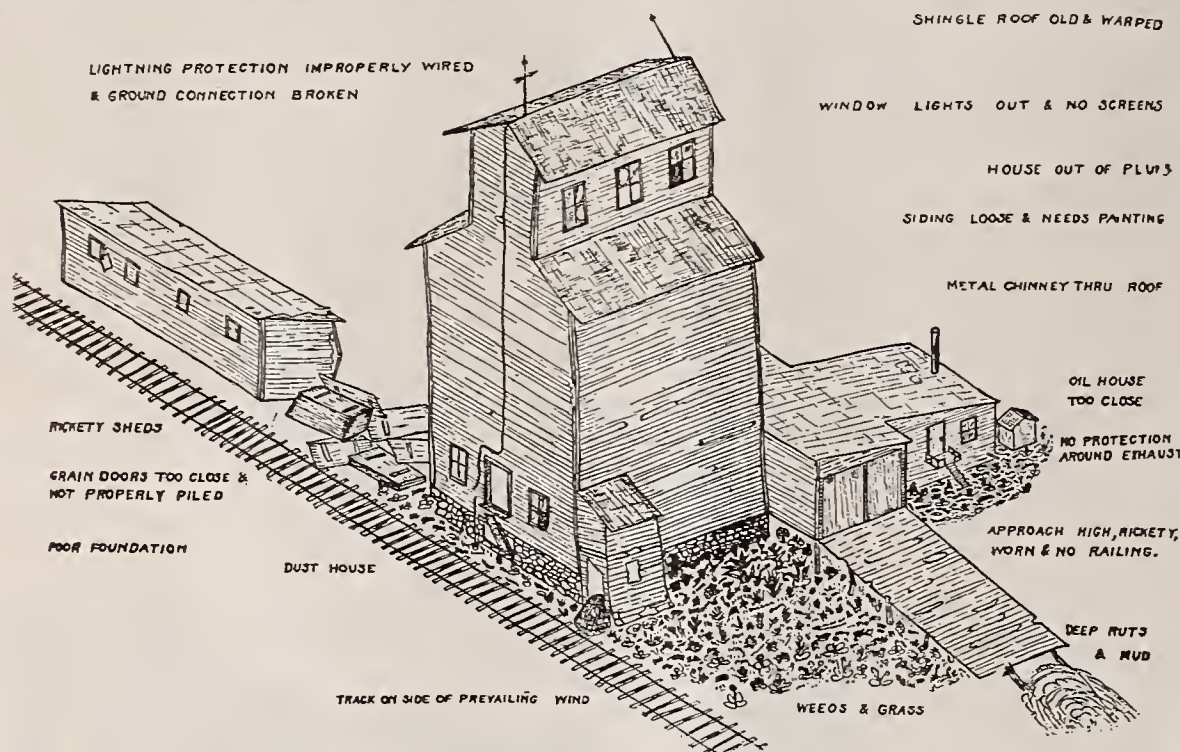

SUCH A DISPLAY OF CARELESSNESS DRIVES AWAY PROSPECTIVE TRADE

ing operations, consider replacing the plain bearings with anti-friction bearings and join those who are singing the praises of anti-friction bearings. If it is not desirable to equip the entire house, begin on the hazardous head and boot bearings as many have done to give ball or roller bearings a trial. Such procedure usually is convincing with the result that the change-over is extended to every bearing in the plant. Your mutual insurance office or the Mutual Fire Prevention Bureau, 230 East Ohio Street, Chicago, Ill., will supply you gratis with a booklet presenting the advantages of anti-friction bearings together with testimonial letters from those using them.

Machinery and line-shafting should receive particular attention. See that shafts are properly lined up so that there will be no binding to cause hot boxes and waste power. Clean out fan cases or cleaners, the heads and boots of elevators and, of course, check all bearings as outlined in the preceding paragraph. If new machines are being purchased specify that they shall be equipped with ball or roller bearings so that advantage may be taken of the saving in power, the reduction in maintenance expense, and freedom from the hot bearing fire hazard. Check over elevator legs to see that cups are running freely without striking the legs, and that the correct tension is maintained on the belts.

If the elevator machinery is driven by electric motors, call in a competent electrician and instruct

preferably one that is located outside of the elevator, detached if possible. The construction of such a building to house the engine is probably one of the most important improvements and investments which can be made as a heavy charge is made in the fire insurance rate when such engines are located inside of the elevator or in an attached combustible power house. Inspect the exhaust pipe of the engine to see that it has a clearance of at least twice the diameter of the pipe from combustible material. The back-fire hazard of carburetion engines is a serious matter if steps have not been taken to protect against it. It has been found that effective protection is secured when the air intake of the carburetor is piped to the outside of the building or at least to a point three feet from the engine. Then if the engine back-fires, the flames are confined within the pipe rather than being permitted to ignite the fuel or vapors surrounding the carburetor. Give the engine a thorough cleaning.

Electric light wiring, particularly if of the open type, is hazardous unless properly installed and maintained. Therefore, instruct your electrician to inspect it thoroughly. If of the open type, rewire it in rigid conduit. Throw out old and worn cotton covered extension cords and purchase the approved rubber jacketed cord which will last a life time. Provide lights on extension cords with an approved guard and outer globe to protect against breakage

COUNTRY FIRM WINS

Arbitration Committee No. 6 of the Grain and Feed Dealers National Association has awarded \$192.51 to E. F. Burlingham, Forest Grove, Ore., in his complaint filed against the General Commission Company, Kansas City, Mo. Messrs. Armstrong, Dial, and Smith, committee members, reported:

"As set forth in argument and evidence, this controversy surrounds a delivery of a car of kaffir corn to Forest Grove, Ore., via the Southern Pacific Railway at Portland, Ore., as provided by a contract made through Fay Malone, broker at Portland, on February 6, 1929. On February 25, 1929, the car arrived at Forest Grove in a heating condition and was so reported to the defendant. After the exchange of several telegrams, the plaintiff agreed with the defendant to apply the kaffir corn on the contract with \$6 a ton discount. The defendant agreed to accept a settlement for the car of kaffir corn at a discount of \$6 a ton and later refused to abide by the agreement, as is clearly shown by evidence.

"We hereby find in favor of the plaintiff for the sum of \$192.51 and assess the costs of this arbitration to the defendant."

Efficient Handling Accounts For This Company's Success

LINED along the right of way of the Rock Island railroad from the Panhandle of Texas through western Oklahoma, the silent sentries of the Riffe Bros. Grain Company annually stand guard over 10,000,000 bushels of grain, a part of the golden avalanche that pours into this section of the country. Like war-time guards these staunch elevators fulfill their duties with dispatch, each caring for an average of 1,000,000 bushels of grain in the course of a year.

Until recently there were but eight in this chain of elevators which helps handle the Oklahoma and Texas crops but a ninth structure was erected only a short time ago and a tenth is expected to reach completion by the time this edition goes to press. The newest plant, which is to be finished by May 15, is located at Goodwell, Okla., in the midst of a rich wheat country. Here wheat can be purchased at a comparatively low figure and shipped to buyers all over the country via the rails of the Rock Island.

The unit erected just prior to this one is at Stratford, Texas, and is a beautiful building of reinforced concrete composed of 10 tanks and capable of storing 125,000 bushels of grain. Over 750,000 bushels of wheat and corn, the only grains handled by the Stratford unit, are received and shipped in a year, slightly less than the average of the entire group of elevators. It has a shipping capacity of 50 cars which is possible with extreme ease and

for coal and feed are handled in addition to grain, is systemized.

Placing all its elevators along the same length of track is another indication of the manner in which the company saves time and labor. In this way, anyone may visit or inspect the 10 plants in a very short time. It is possible to start at either the southwestern or northeastern end of the chain and see the entire group of plants inside of a day. By this arrangement, any elevator becoming overstocked, or in danger of being overstocked, can be relieved in a few hours by merely shipping the surplus grain to a less congested unit. This means



RIFFE BROS. TEXHOMA ELEVATOR

The City of Texhoma is Located on the Texas-Oklahoma Boundary, But the Above Grain Unit is on the Texas Side

a more even distribution of work throughout the plants.

All the company's elevators are kept in excellent repair and as soon as machinery shows signs of wear and is not delivering at capacity it is either fixed or, if it is thought to have outlived its usefulness, replaced. This insures against loss of time at a critical moment when worn-out and re-patched equipment has a habit of breaking down, often resulting in the loss of many precious hours. Nothing is gained by lax care of machinery, the company officials contend, while there is much to gain by proper care. Using antiquated machinery is not saving and ultimate replacement is necessary anyway.

It is during the harvesting and marketing of the Winter wheat crop that the Riffe Bros. elevators are taxed the most, for Texas and Oklahoma are two of the largest Winter wheat producing states in the country, Oklahoma being outranked in production only by Kansas and Nebraska. According to the latest figures available, Oklahoma produced 59,576,000 bushels of wheat and 70,150,000 bushels of corn in 1928 while Texas, the fifth largest wheat grower, produced 22,176,000 bushels of wheat and 99,162,000 bushels of corn. In addition to drawing grain from these two sections, the surplus of other near-by states, like Kansas and Colorado, is available so there is never a scarcity of grain.

The increased export facilities of Texas' two largest grain ports, Houston and Galveston, is expected to have a favorable effect on the company's business for while little exporting is done by Riffe Bros., the erection of large terminals at these Gulf ports means that grain from all over Texas and Oklahoma will move much faster than formerly when thousands of cars loaded with grain were known to stand, waiting for ships that never came in. This meant that much of the crop was in poor condition when it was finally shipped to other markets and consequently brought a lower price. The

new 6,000,000-bushel Galveston elevator, the largest port terminal in America, is being built to insure maximum handling speed and will be able to transfer 200,000 bushels of wheat an hour into boats. While not as large as the Galveston unit, the Houston plant when completed will be able to house 3,500,000 bushels, which means that a total of 9,500,000 more bushels of grain can be handled than was previously possible. This gives Riffe Bros., and all other southwestern elevator concerns, an enlarged market.

The 10 company elevators are located at the following points along the Rock Island: Stratford and Stevens, Texas; Goodwell, Optima, Hooker, Tyrone, Mauner, Hough, Baker, and Texhoma, Okla. The last-mentioned town is located on the boundary line dividing Oklahoma and Texas and although the Riffe Bros. elevator there is not "half on one side of the line and half on the other", as certain oddly-situated buildings are reputed to be in various



125,000-BUSHEL PLANT AT STRATFORD, TEXAS

speed with a minimum of manpower because of the efficient and modern machinery used. This is a criterion of the entire plant's equipment, for everything is strictly up to date and nothing is left to chance.

Two electric motors take care of the power problem, developing 30 horsepower which is sufficient to operate the plant, even at top speed. All weighing is done by 10 automatic scales.

The operation of this elevator, like the others controlled by the Riffe Bros. Grain Company, is on a highly-organized system. There are no lost motions; everything is made to count. Efficiency without undue censorship of the employe's actions is the rule, and everyone adheres to it closely. There is little waste and even the sideline business,

state boundaries, its employes' come from both states. An interesting fact concerning the sites of these 10 elevators is that they are near no large city, the nearest Texas city of any size, Fort Worth, being about 350 miles away, and the closest Oklahoma city, Enid, 130 miles away.

300 CHEMICALS AS GRAIN FUMIGANTS

Wanted: A fumigant for insect-infested grain that will be better and safer than carbon disulphide. This was the problem placed before the chemists and entomologists of the United States Department of Agriculture. It turned out to be a big job.

Before the investigators finished they made more than 6,000 tests and killed more than 100,000 insects, every one of which was counted before it was killed in the test tubes, in the laboratories, or in a fumigation vault. In the tests the workers used more than 300 compounds or mixtures of chemicals which they thought might prove fatal to insects such as infest grain foodstuffs, carpets, and clothing.

The rice weevil is difficult to kill. So the investigators selected this weevil to provide a stiff test for their fumigating mixtures. They counted weevils into vials by tens, buried the vials in wheat in glass flasks, and added measured doses of chemical mixtures. Then they left the weevils for 24 hours and counted the survivors.

Some of the fumigants that killed all the weevils are dangerous to use. Others are too expensive. Finally, the choice narrowed to two or three of the most promising compounds. Ethylene oxide and ethyl monochloroacetate proved slightly more effective than carbon disulphide. Three parts of ethylene dichloride mixed with one part of carbon tetrachloride is regarded as highly promising because it is effective, cheap, less dangerous to human life and property than carbon disulphide.



Published on the Fifteenth of Each Month
BY

Mitchell Brothers Publishing Co.

OFFICE:

Manhattan Building, 431 South Dearborn St.
CHICAGO, ILL.

A. J. MITCHELL.....Business Manager

New York Representative: E. M. Roberts, 587 Riverside Drive
Telephone Edgcomb 7172

Subscription Price - - - - \$1.00 per Year
English and Foreign Subscription 1.75 " "

ADVERTISING.

This paper has a large circulation among the elevator men and grain dealers of the country, and is the best medium in the United States for reaching persons connected with this trade. Advertising rates made known upon application.

CORRESPONDENCE.

We solicit correspondence upon all topics of interest connected with the handling of grain or cognate subjects.

Official Paper of the
Illinois Grain Dealers Association

CHICAGO, ILL., MAY 15, 1930

THE COLORADO CRITIC

FRANKLY criticizing the Federal Farm Board from a business viewpoint as a departure from traditional national economic policy, Daniel A. Millett, investment banker and stockman, of Denver, Colo., advocated the repeal of the Agricultural Marketing Act and downward revision of the tariff as a substitute remedy, at the eighteenth annual convention of the United States Chamber of Commerce this month. He said, after an analysis of the act and reviewing the problems in the administration of it:

The setting up of what practically amounts to a new department of government under this act, must of necessity entail increased governmental expense. I am well aware that the act is hopeful, that under the operative agencies established a profit will be earned which will carry the load. On the other hand, many well-informed people believe that unless great care is exercised the entire revolving fund of one-half billion dollars will finally be lost, and under the express encouragement in the law itself to make loans beyond safe banking practice, to build and operate warehouses, to operate upon the open commodity markets of the world, it does not seem reasonably possible that other than loss can result, no matter how faithfully the men charged with the administration of the law perform their duties. The pressure and incentive to financial success are absent.

Not only is there the question about the loss of the public treasury money through operations; there is also the expense of maintenance of the organization. Frankly, it has seemed to me that the Department of Agriculture, as organized, could perform all of the sound functions placed on the shoulders of the farm board, with comparatively little additional expense. When I say sound functions, I refer to the dissemination of scientific agricultural knowledge and economic possibilities as to world production, consumption, demand and marketing. I believe the Depart-

ment of Agriculture could do the work of organizing co-operatives, which would be the farmers' own co-operatives, because they would have to be financed by the farmers, not by the Government.

It is important to note that Mr. Millett's opinion is based on facts aside from the fact of the act's discrimination against private initiative. It is true that the law in question may logically be condemned as unsound without reference at all to backhand swipe it gives the grain trade.

STORAGE FACILITIES AS A WHEAT PRICE FACTOR

WHILE newspaper reporters have been twisting weather reports into all kinds of shapes in an effort to explain why wheat prices have sagged to the dollar mark, traders are admitting that a most potent influence serving as a drag on prices is the question of grain storage facilities for the new crop.

The latter theory is tenable, although it cannot be denied that rain reports from the Southwest have been responsible for some of the decline in ticker figures. In certain sections of Texas, Oklahoma, and Kansas, however, the drought preceding the rain was so severe that no amount of moisture could make up for the damage at this late date.

But the likelihood of congested storage conditions in the near future cancels whatever optimism one can extract from the weather bulletins. If more wheat is not exported during the months of May, June and July than in the corresponding months of last year, storage congestion will be unprecedented. Elevator building in the Southwest has been going on steadily, but much more is needed before the capacity rating will match requirements.

MAY-JULY WHEAT PRICES

A NOTABLY high level of visible supplies in North America, an unprecedentedly small post-war volume of international trade, and a sharp decline of wheat prices from early January to the middle of March were the outstanding features of the world wheat situation during the period from December, 1929, to April, 1930, according to the May survey of the wheat situation, published by the Food Research Institute, Stanford University, California, in the last issue of "Wheat Studies." The movement to Europe was strikingly small; and since export supplies available were large, the causes of the notably small movement must be sought principally in the European situation.

Available evidence suggests that in Europe a combination of circumstances—a mild winter, relative cheapness of rye and the feed grains, business depression, and the good quality of the domestic wheat crop of 1929—made for relatively small consumption of wheat both for food and feed. Importers purchased sparingly. This situation appears to be the dominant cause of the small volume of international trade and, in combination with the heavy stocks in North America, contributed greatly to the price decline of the

period from January to March, although other factors were also operative. Russia appeared on the world market as an exporter of wheat.

The record of past years and recent developments in the present suggest certain features of the world wheat situation that may become prominent in the closing four months of the crop year 1929-30, subject inevitably to the changing prospects for 1930 crops. The volume of international trade during 1929-30, as measured by net exports of wheat and flour, now seems likely to reach only around 660,000,000 bushels or less, the smallest in post-war years. A crop scare might prompt a larger movement.

World exports in the April-July period may reasonably be expected to exceed those of December-March, modifying the average post-war seasonal movement. European importers early this spring seem not to have been in as favorable a position for curtailing purchases as they were in early December.

The movement of wheat prices in the May-July season will presumably respond more sharply to changes in new crop prospects than to other influences. But if the world wide business situation and the feed grain situation improve, if import demand becomes more active, and if the growing crops do not encounter unusually favorable weather conditions, prices may tend to rise despite continuing heavy North American stocks.

EXPRESSING CONFIDENCE

IN THE face of the threat to privately owned business, as represented by the activities and declarations of the Federal Farm Board, elevator companies are again going forward in a program of capacity expansion.

This fact reflects, perhaps, a belief that is widely accepted by the trade this spring, and this belief is that repeal or drastic modification of the Agricultural Marketing Act is inevitable. Thus, the farm board and its agencies are looked upon as temporary, rather than permanent hazards.

The Milwaukee *Journal* paints the picture a trifle too rosy when it declares that "not in recent history has there been such an expansion of building for grain storage." It is true, however, that a reaction has set in against the government-in-business scare. Dealers are more opposed than ever to Uncle Sam in the role of competitor, but their morale has been strengthened and their routine of expansion resumed after a spectacular demonstration that, as a grain dealer, Uncle Sam is definitely clumsy.

Federal Farm Board spokesmen, its chairman included, have been at no pains to conceal their contempt for grain-trade protestants against the Agricultural Marketing Act. Sarcastic references to the grain trade have been common. In view of the fact that the grain trade somehow has been able to survive these verbal onslaughts, we are seriously considering hauling out and polishing off that quaint old adage concerning a barking dog.

EDITORIAL
MENTION

Last fall, S. R. McKelvie, wheat member of the Federal Farm Board, declared its agencies would handle 500,000,000 bushels of the 1930 crop. From present indications, it will be entitled to a pat on its official back if it handles over half that volume.

Recent articles condemning the Agricultural Marketing Act include those published in *Harper's* and the *Atlantic Monthly*. The clipping bureau hired to clip favorable comments on current farm relief projects is having an easy time of it.

Wayne Dinsmore, secretary of the Horse Association of America, says the grain surplus is due to the decline in horses. As he reads of wheat sinking to a dollar, a certain expression comes over his face, as two years ago he wagered that wheat would go 75 cents a bushel within five years. We showed his letter to a mounted policeman outside our office, and he said Mr. Dinsmore probably was right, but that personally, he'd like to be transferred to the motorcycle squad.

A Chicago daily drew a round of our personal applause with this brief published comment: "To Senator Nye, of North Dakota, goes the grateful tribute of all who enjoy a well-mixed metaphor. The excerpt that follows is from the Congressional Record's report of the senator's discussion of grain traders and the farm board: 'I feel confident that the purposes of this troop of pirates in the grain trade, these economic leeches in the Northwest, these barnacles on the grain-marketing ship, will be unhorsed and diverted from their purposes.'"

Here in the Middle West, where bulk handling is as common as daylight, it is almost startling to get an inquiry such as H. G. Corker sends us. From 51 Maple Avenue, Goodwood, South Australia, he writes: "I would like to know how you people in the U. S. A. handle your wheat crops in bulk. Kindly advise." We didn't know just where to begin and after we began, we didn't know where to stop. Is there, by chance, some reader who knows how to handle bulk wheat so well that he can tell how in a short, snappy letter?

For several years grain inspectors have conducted a campaign relative to the even loading of cars, stressing the advantages of having grain of the same quality throughout the load in order that representative samples may be easily secured. How the industrial world considers this question of sampling in other lines is summarized by Dr. Charles B. Dudley, president of the American Society for Testing Materials: "The purchaser has a right to assume that every bit of the material making up a shipment meets the requirements of the specification, since this is what he contracted for and expects to pay for. It should make very little difference, therefore, what part of the shipment the sample comes from, or how it is taken. Aver-

age samples made up of a number of sub-samples are only excusable when the limits of the specification are so narrow that they do not cover the ordinary irregularities of good practice in manufacturing or loading."

While Chairman Alexander Legge of the Federal Farm Board is striving to reduce wheat and other surplus crop acreage, other Government agencies will continue to encourage agricultural development in new areas. Officials of the other agencies, notably the reclamation bureau of the Interior Department, are forced to go forward with their programs in the hope of recovering the Government's money from so-called "revolving funds." Mr. Legge has expressed his opposition to the development of new reclamation enterprises, but he has about as much chance cutting the Interior Department's acreage as he has of reducing that of the farmers.

CROSS SECTION NOTES ON
THIS ISSUE

How could the Federal Grain Stabilization Corporation get along without the St. Louis Merchants Exchange personnel? See St. Louis news letter on Page 675.

Pneumatic messenger service for modern elevators: Page 669.

Accounting principles to serve the needs of elevator managers: Page 660.

Dehydrating as applied to the hay trade of Louisiana: Page 679.

A picture of the world's worst run elevator: Page 662.

A pelican grain trier—among the grain trade details mentioned in the illustrated article beginning on Page 659.

The answer of American Business to the Federal Farm Board as reflected in the United States Chamber of Commerce resolution: Page 687.

A modern mill elevator in the Hoosier State: First Page.

"A periscope for the use of grain inspectors in corn markets: Page 658.

"Ifs" on which depend a rise in wheat prices—see "May-July wheat Prices" on preceding page.

Liberally furnished with grain-trade epigrams: G. M. Flaherty's story on Page 670.

Convention addresses and notes of the Illinois grain dealers' congress at Decatur: Beginning on Page 683.

The United States Department of Agriculture has submitted to the Senate its final report regarding the effect of suspending, between February 26 and October 31, 1927, certain daily reports required to be made to the Grain Futures Administration concerning the operations of large traders in grain futures. Dr. J. W. T. Duvel, head of the Grain Futures Administration, in commenting upon the results of the suspension as set forth in the formal report to the Senate, said: "The reports upon operations of large traders have been regarded always as essential to effective regulation of the futures

markets and to prevent manipulation of grain prices. Unfortunately, this view was not shared by all interests in the speculative grain trade, and for years there have been broadcast statements and reports to the effect that these reports were keeping large speculators from operating in the wheat futures market who otherwise would be heavy buyers and whose support, if the reports were dispensed with, would result in higher prices to producers. Most of the known large speculators have been in the markets at the very time these claims were being pressed most urgently, but without an actual test it could not be determined definitely how many unknown interests there might be who would enter the markets if the reports were dispensed with. When the principal grain exchanges themselves were persuaded into representing officially to the Secretary of Agriculture, early in 1927, that the reports in question were responsible for the low price of wheat and that improvement would result from their suspension, the then Secretary of Agriculture, Wm. M. Jardine, decided that the most satisfactory way of determining the facts was by actual trial and demonstration. Accordingly, the reports were dispensed with, effective February 26, 1927, and were not again required until November 1. The department's investigation disclosed that during the eight months the reports were suspended the greatest number of speculators, large enough to be affected by reporting requirements, that were in the Chicago wheat futures market at one time was 39; that during January and February prior to the suspension there were six days when 39 speculators large enough to be reported were in the wheat market at the same time, but that during the entire eight months the reports were dispensed with there were only two days when that many were in the market at the same time. The report further shows that during the period of suspension there were seven speculators who acquired a net position in all Chicago wheat futures of at least 2,000,000 bushels. Six of these seven were in the market before the reporting requirements were suspended, but instead of supporting the market each was 'short' when the reports were suspended and had been for some time. One of the seven came in later on the 'long' side, but was not a new trader. Considered collectively, the group of seven had a short position in the wheat market during six of the eight months of the suspension and only one of the seven did any buying for long account immediately following suspension, and he was on the long side for only a few days before selling his holdings. This group of seven, which, considered collectively, was net short slightly more than 7,000,000 bushels, the day before the suspension, practically doubled its short commitments by April 19, when it was 13,430,000 bushels net short. By actual demonstration the claim that the removal of reporting requirements would attract large buyers and enhance prices was shown (according to the Government's interpretation) to be unjustified, and the eight-month suspension, by settling this important question, is regarded (by the Government) as having served a useful purpose." The words in parentheses are ours, all right.

J. G. McKILLEN
Buffalo

NEWS OF THE TERMINAL MARKETS

E. M. COMBS
Chicago

NEW SEATTLE MARKET BROADCAST POPULAR AMONG GRAIN MEN

The early morning broadcasts of the Seattle Grain Exchange, begun over a month ago on radio station KOMO, giving the opening and "present" market quotations as well as a digest of market news from Buenos Aires, Liverpool, Winnipeg, Minneapolis, Chicago, and Seattle, are becoming quite popular among coast grain men. This service is in addition to the final market news letters broadcast over the same station.

The addition to the regular market schedule was made in response to the request of radio listeners who wanted up-to-the-minute information concerning the movement of wheat values on the Seattle futures market and the prominent grain centers of the United States, Canada, and other foreign exchanges.

For the past year or more the Seattle Grain Exchange through its committee on public relations has prepared a daily market letter immediately following the close of the grain markets, which has been broadcast by KOMO, but the rapidly increasing interest on the part of producers and buyers in the Pacific Northwest has justified the new schedule arrangement.

The time of broadcast of the early market information necessarily varies from day to day, as it must be placed between regular feature programs, but it usually goes on the air some time between 9:30 and 10 a. m.

FORESEES LOW WHEAT PRICE IF FARM BOARD PLANS SUCCEEDS

If the theory of co-operative marketing on which the Federal Farm Board is now working is ultimately carried through and the existing grain exchange system is demoralized, farmers of the future will not get the money for their grain that those of the past have, declared A. L. Flanagan, newly elected head of the Milwaukee Chamber of Commerce, in his inaugural address.

"I wonder if the farmer and the public generally know that grain is handled on the smallest margin of profit of any other commodity and yet is the most liquid, or easiest to turn into cash without sacrifice," he said. "The commission man gets \$10 for soliciting, selling, and financing a car of grain worth \$1,000. Compare that with the \$100 to \$500 that is made on any other commodity or article you may wish to mention. And yet some politicians who do not know or understand what a great benefit to the farmer and the nation the grain exchanges are, would with a stroke of a pen scratch us from the commercial make-up of this country."

President Flanagan feels that the grain trade is going through a critical period, one that is testing its soundness and showing it to be the only satisfactory way of marketing grain.

"It is my judgment," he stated, "that a marketing system built up by over 100 years' of experience and built on the highest, soundest, and most honest business ethics possible with its buyers and sellers of grain for so many purposes and its futures markets for the protection of producer and consumer alike, *will not perish!*"

"It will mean, however, that we must all watch our overhead carefully, work harder, and in due time the Government will be convinced that the grain trade is performing a service to the producer and consumer alike at the smallest handling cost of

any other commodity in the world and a service that neither they nor the nation can do without, if prosperity in this country is to continue."

LIST OF COMMITTEES

The complete list of committees has been given out and Milwaukee members are advised to see the following chairmen when in need of assistance: Committees of the board of directors—A. L. Jacobs, finance; L. J. Keefe, furniture and rooms; Joseph Mueller, grain to arrive; P. P. Donahue, market reports; J. V. Lauer, membership; O. R. Eickert, rules and regulations; Herbert H. Ladish, supplies; and Edward LaBudde, transportation. General committee heads—E. H. Hiemke, grain inspection and weighing; barley cash closing, W. F. Lodde; corn and oats cash closing, W. R. Madden; wheat and rye cash closing, A. E. Lauer; membership, W. C. Holstein; publicity, A. E. Bush; weather reports, W. Young, Jr.; business conduct, H. H. Peterson; commerce and manufacturers, G. P. Miller; grain, A. L. Flanagan; auxiliary, R. G. Leistikow.

E. E. McCONNELL, NEW CORN EX- CHANGE PRESIDENT, FINDS TIME FOR FISHING

By ELMER M. HILL

E. E. McConnell, prominent Buffalo, N. Y., grain broker and commission merchant, and newly elected president of the Buffalo Corn Exchange, proves a very interesting and entertaining character to interview.

Mr. McConnell's past history sounds a good deal like an Alger book, for he is among the grain men who have "worked their way up from the bottom."

For 16 years, this man has been president of his own company, without partners or outside interference of any kind—he has weathered the trade ups and downs, and declares he is well satisfied with conditions in general.

However, a good number of years before this, Mr. McConnell learned to take orders, so that he would know how to give them. His first grain and feed

job was a humble one, for Mr. McConnell started out as a messenger boy for the Cleveland Grain Company, Indianapolis, Ind. As he learned more about the feed and grain methods of those days, he was promoted from job to job, until he found himself on the road for that concern. One position led to the other, and Mr. McConnell benefited by varied experiences in all stations of the trade.

Then turning his interests more toward the Great Lakes region, he associated himself with the Eastern Grain Corporation of Buffalo, where he served in many capacities, and made widespread acquaintances.

Finally it came his turn to be listed as one of the pioneers and leaders, with the result that he now has offices on the twelfth floor of the Chamber of Commerce Building and divides his time between the office and exchange floor.

With regard, particularly, to Buffalo's grain, feed and milling trend, Mr. McConnell says:

"I believe that the flour milling and manufacturing of dairy feed, chick feed, mash and so on has developed to a point today, where it is only a question of either first or second place in the milling industry here. This indicates, I think, that we are almost the largest center of dairy and chick feed manufacturing in the world."

It is not difficult to understand why this man has been so successful, inasmuch as optimism is not only a part of his daily work, but a part of Mr. McConnell himself.

"It has been my happy privilege," says Mr. McConnell, "to witness Lake Erie traffic grow, from year to year. From this window, I watch the departure of the first boat in the spring, and see the last to make port in the late fall. A sight of this kind, is to me not only interesting to the eye—but food for thought, and I frequently catch myself day-dreaming a bit about the Lake Erie traffic of—tomorrow!"

Mr. McConnell recognizes the "all work and no play—" adage, and is a member of the Buffalo Canoe Club. During the summer months, he spends some time on the lakes. However, his principal hobby is fishing, and it is quite safe to say that he knows when and where they bite—inasmuch as he has been following them up here and elsewhere for a good many years.

Although lake traffic has been threatened with a rather tardy opening, Mr. McConnell sees a good season ahead, and holds that the market prices are running along more or less in a normal manner at this time.

CANNOT REFUSE CAR AFTER INDEFINITE TIME EXTENSION

In a case featured by "negligence and careless handling" by both parties, the Huttner-Foster Company of Minneapolis was ordered to pay to the Tri-State Grain Company of Shenandoah, Iowa, the sum of \$155.83. Arbitration committee No. 5 of the Grain and Feed Dealers National Association, which granted the decision, decided that when a buyer grants an indefinite extension at the expiration of a contract he must accept a car shipped within a reasonable extension of time.

The Huttner-Foster Company, defendant in the case, was under contract to accept three cars of No. 1 Hard wheat from the Tri-State Grain Company, but owing to an unavoidable delay only two cars were received within the time stipulated in the agreement. The defendants, when informed by



E. E. McCONNELL

the plaintiff that the third car would not be shipped on time, agreed to grant an extension of time but no definite date was set. A week later the defendants wired that they were cancelling the one car not shipped and refused to accept delivery.

The committee decided that the extension was granted and that the application of the third car on the contract was entirely proper so the Huttner-Foster Company must pay the Tri-State Grain Company \$137.48.

A second decision was returned against the defendant for \$18.54 because of a difference in price in the account of sales which clearly was in error, making a total of \$155.83 which the Huttner-Foster Company was obliged to pay. Costs of the trial were divided equally between the disputing parties.

NOMINATE WINCHESTER NOYES FOR N. Y. EXCHANGE PRESIDENCY

The New York Produce Exchange Nominating Committee has officially announced the nomination of officers and managers to be put before the members for election on June 2, 1930, who are: For president, Winchester Noyes, of J. H. Winchester & Co.; for vice-president, A. C. Field, of Field & Morgan; for treasurer, John E. Seaver, of Seaver & Seaver; for Board of managers, to serve two years, J. A. Robinson, of Robinson & Armstrong; T. R. Van Boskerck, of George W. Van Boskerck & Son; Arthur Dyer; Carl F. Andrus, of C. W. Andrus & Son; R. W. Capps, of Zimmerman, Alderson, Carr Company; and L. C. Isbister, of Isbister & Schied; for board of managers, to serve one year, Samuel S. Lerner, of G. & A. Seligman; for trustee, gratuity fund, R. M. Morgan, of Field & Morgan.

Mr. Noyes, nominated for the presidency of the exchange, was born in Brooklyn, N. Y., on March 14, 1878. He is a grandson of James H. Winchester who founded the steamship brokerage firm of J. H. Winchester & Co., in 1866. Mr. Noyes is thus the third generation to be at the head of the old company with which he has been connected since 1899. During that year he began to represent the concern on the floor of the New York Produce Exchange and has been an active member ever since. He has always taken a lively interest in the affairs of the exchange, having served on various committees and on the board of managers for nine years. He is also a member of the New York Maritime Exchange.

William Beatty, in terminating his third term as president of the New York Produce Exchange, states that during that time he has worked incessantly for the inauguration of a securities market on the exchange and is retiring from the presidency with a great feeling of satisfaction in seeing the phenomenal success of the securities market, in which he had every confidence from its inception. Mr. Beatty has been an active member of the produce exchange for 31 years and has served on the board of managers and on many committees and he now feels the exchange should have a younger man at its head.

A. C. Field, who has been nominated for the vice-presidency, is also in every way well fitted for this office as he has served on the board of managers, and also for six years as chairman of the grain committee and on several trade committees.

YELLOW CORN MOVING AT PEORIA

Since our last letter the market has been running along in a rather respectable way with corn the principal grain handled here. It has been comparatively easy to get enough corn headed this way to keep our industries going and also to supply quite a large amount of the better Yellow grades, for shipment. The industries are using now approximately 75,000 bushels of corn daily. There has been a good demand here for all sorts of corn and the sample grade corn has met with rather good results for the shippers. There is a vast difference in the value of sample grade corn, running all the way from 50 to 73 cents. The 50-cent type is, of course, very poor, badly damaged, and sometimes very hot and musty. The better grades have been selling at about same relative basis as in other primary markets, taking freight differences into consideration.

The movement of corn right now is not at all heavy and the arrivals in all markets are bordering on being light. It looks as if there might be a little more selling by farmers unless market has too much of a break, in which case we doubt if any farmers would sell corn. It is held at country points by farmers who are able to hold it if they want to. However, we presume the Peoria market will adjust itself for changes for either a high or low in other markets.

Oats arrivals have increased somewhat during the last few days but we see no indication of any great amount of oats being held anywhere and it looks as if, with more than two months until the new crop makes its appearance, that prices should do better. They are certainly low right now but the trade generally is dull. A while back there was about 1,250,000 bushels of oats in Peoria elevators and this now is down to almost nothing.

Agricultural prospects throughout Illinois look very good indeed at the present time. Corn will all be in the ground within a few days and the growing oats are said to look fine.—P. B. & C. C. Miles, mid-May letter.

WILLIAM S. MILES DIES

By IVAN L. REVEAL

The Peoria Board of Trade paid unusual tribute to the memory of William S. Miles, secretary of the firm of P. B. & C. C. Miles on April 17, by suspend-



THE LATE WILLIAM S. MILES

ing operations upon the announcement of his death. Highest tribute to his character and standing in the business world was paid by B. E. Wrigley, president of the exchange, Homer H. Dewey, N. R. Moore, and other of his associates. A memorial expressing the sorrow and the sense of loss sustained by the Peoria Board of Trade was adopted at the Saturday session.

A desperate fight against double pneumonia was lost by Mr. Miles when he was claimed by death on the morning of April 17, at his home, 435 Moss Avenue, Peoria. For several days oxygen had been used to keep up his strength. He had been ill one week, first with influenza and later with pneumonia.

Mr. Miles was active in many community enterprises. He was keenly interested in music and was a charter member of the Orpheus Club, a Peoria musical organization. He served for four years as a member of the Peoria Board of Education, and like his father, was honored by being elected president of that body. He had also served as president of the Peoria Board of Trade, and was chairman of the golf committee for the convention of the Grain and Feed Dealers National Association in Peoria last fall. He was a member of the committee appointed by the city council to lend advice in the building of the river terminal, for the city of Peoria.

He was born in Peoria, June 2, 1876, the son of Philo B. Miles, and Maria H. Miles. After graduating from high school there he entered Princeton

University where he received an A. B. degree in 1899. He then became associated with the grain firm of P. B. and C. C. Miles of which his father is the senior member, and continued with this firm until his death.

On June 7, 1904, he was married to Miss Bertha E. Heidrich of Peoria. Mrs. Miles and one son, William S. Miles, Jr., survive him. He is also survived by his father, Philo B. Miles, and one sister, Mrs. Frederick M. Birks of Peoria.

Mr. Miles was active in fraternal circles and was a member of the York Rite and Scottish Rite Masonic bodies. In the affairs of the Grain and Feed Dealers National Association, he had taken an active part for many years.

MONTREAL RECEIPTS AND SHIPMENTS

Receipts and shipments for February and March, which have been held up for a long time, have finally been released from Montreal by J. Stanley Cook, secretary.

The February figures for 1929 and 1930 are as follows:

	Receipts		Shipments	
	1930	1929	1930	1929
Wheat, bus..	525,531	574,978	13,989	62,562
Corn, bus....	25,710	26,231	920	3,584
Oats, bus....	242,130	376,809	18,497	52,837
Barley, bus..	86,006	71,293	4,983	3,075
Flaxseed, bus	16,700	31,566
Hay, bales...	23,531	55,940
Flour, bbls..	109,851	117,558	47,117	86,723

The March figures for 1929 and 1930 are as follows:

	Receipts		Shipments	
	1930	1929	1930	1929
Wheat, bus..	390,951	216,530	15,668	157,997
Corn, bus....	16,500	21,440	1,299	7,263
Oats, bus....	176,551	361,393	10,531	60,928
Barley, bus..	32,783	110,749	15,081	10,463
Flaxseed, bus	54,640	65,100
Hay, bales...	31,255	40,356
Flour, bbls..	153,462	106,289	75,163	96,402

VOTE TO AMEND KANSAS CITY RULES

The Kansas City Board of Trade directors voted to recommend the following change in the rules and add the following new section to article 3: "No warehouse receipt more than six months old shall be valid for delivery on a futures contract unless said receipt shall bear an endorsement showing that accrued elevator storage charges have been paid up to date of delivery; such indorsement may be made at the option of the holder by the regular warehouse issuing the receipt, or by the secretary of the board of trade upon payment to him as agent of the warehouse company. The proposed change is for the purpose of establishing a time limit on accrued storage charges for deliveries on futures contracts."

WHEAT RECEIPTS SHOW INCREASE

Our receipts of wheat have shown a decided increase the last two days but this is occasioned from the fact that the farm board is taking advantage of some vacant Indianapolis storage. We are having, however, a fairly good demand for good Soft Red Winter wheat. No. 2 Soft Red Winter wheat sold here yesterday at equal to 10 cents over the May delivered Ohio River rate points.

Corn receipts have held up surprisingly well and only during the last few days have they shown a decided decrease. We have a very good demand for good White and Yellow corn. Off grade corn and especially corn that will have to be dried is selling at pretty sharp discounts and is in very poor demand.

Oats receipts have been rather heavy and at times a little burdensome. The demand has been erratic but in spite of the good movement in our direction spot oats have sold nearly every day at better than the commission above bids for shipment. However, the last few days oats receipts have shown a decided falling off.

We look for decidedly light receipts until after corn planting and if prices continue much lower we may not see much, if any, after the corn planting movement.—Cleveland Grain Company, letter of May 10.

GRAIN FUTURES SHOW INCREASE ON CHICAGO EXCHANGE

An increase of 170,827,000 bushels was manifest on the Chicago Board of Trade grain futures market last month when 1,610,109,000 bushels were traded as compared with 1,439,282,000 bushels the preceding month. The total was divided among the various grains in the following manner, March figures being shown in parenthesis for comparison: Wheat, 1,259,039,000 bushels (1,028,026,000); corn, 252,347,000 bushels (297,395,000); oats, 48,563,000 bushels (38,599,000); and rye, 50,160,000 bushels (75,262,000).

Average open contracts on the Chicago exchange for April, "short" side of contract only being shown, there being an equal amount on the "long" side, were: Wheat, 161,151,000 bushels compared with 146,314,000 in April, 1929, and 172,168,000 in March, 1930; corn, 49,962,000 bushels against 68,315,000 in April, 1929, and 49,827,000 in March, 1930; oats, 25,410,000 bushels in contrast to 25,671,000 in April, 1929, 30,327,000 in March, 1930; and rye, 21,150,000 bushels compared with 8,971,000 in April, 1929, and 15,512,000 in March, 1930. The average open contract for all grain at Chicago in April was 257,672,000 bushels against 249,271,000 in April, 1929, and 267,834,000 in March, 1930.

MARKET RESTRICTED BUT STEADY

Very light movement of old wheat, mostly of inferior quality is weevily or heat damaged, and naturally is bringing rather low prices. New wheat in this state is coming along very nicely and looks as though we are going to have a bumper crop. We have had good rains and warm weather in the past two weeks and we do not believe we have ever seen the crop look more promising.

Receipts of corn are dropping off a little, while farmers are busy planting the new crop, which is going in under excellent conditions with an increased acreage, and we hear of new corn already peeping through the ground in several sections of the state. Cash corn here has been in good demand at prices equal to other markets for the good corn, but the poor corn is still selling in this market to better advantage than in any other market, freight differences considered. We look for a good demand to continue unless receipts get burdensome.

Receipts of oats are increasing while the demand is only fair. No one seems particularly anxious to take on any unless he has immediate use for them. The new crop is coming along nicely. Weather the past few weeks is seemingly just made to order for oats and there also is an increased acreage of them, in fact the country today looks like a picture. Our market has kept pace with other markets on the price of old oats and we look for a fair demand to continue.—*Mueller Grain Company, Peoria, Ill., letter of May 12.*

MARKET HOLDING WELL IN PITTSBURGH

Corn receipts are fair, and generally showing up better in quality, especially Indiana and Illinois receipts. This corn is testing No. 2 and No. 1, and moisture test 13½-15½ per cent. Consignments of corn can be recommended, and stocks here are light. Some No. 3, No. 4, and No. 5 corn is arriving, and it is placed on the market at about two cents discount for each grade down. All consignments should be billed for Pennsylvania Railroad delivery. The market values here are in line with other markets, and some cars bring a slight premium.

Oats stocks are the lightest of the season, and receipts have been light, also. There are more oats offering from country points in the past week, but there seems to be quite a little improvement in the demand, which is taking care of the increased offerings.

Rosen rye is in fair demand, but only an occasional car needed.

If the grain trade would forget about the grain Stabilization Corporation for a while, and get over their unreasonably bearish attitude, it would be a whole lot better for everyone concerned. It occurs

to us that there has been enough dissension of bearish opinion to demoralize the trading. Everyone concerned in the grain and feed trade, from the consumer up, is so saturated with ideas of extremely low prices being possible that they are not in the humor to do business normally. We sincerely trust it will not be long now until a decided change of heart is seen along this line.—*Harper Grain Company, Pittsburgh, Pa., letter of May 13.*

CHANGES IN MEMBERSHIP

Chicago.—The following have been admitted to the Chicago Board of Trade: Henry P. Russell, of Russell, Miller & Co.; Elwood P. McEnany, of the All States Trading Company; Elmer P. Kayser, of Gorman, Kayser & Co.; J. Harsen Halsted, of W. H. Story & Co.; Martin J. Hogan, of the M. J. Hogan Grain Company; Edward E. Tanner, Jr., and Willard B. Cook. Memberships transferred were those of John L. Luebbing, J. Leonard Repogle, Frank L. Kidder, Walter F. Schultze, estate of Thomas H. Story, Norman M. Weiss, and the estate of Martin J. Hogan.

Duluth.—J. R. McLean was admitted to the Duluth Board of Trade.

Kansas City.—Vincent O'Dowd, of the Arcady Farms Milling Company, was admitted to the Kansas City Board of Trade while Wallace C. Bagley, of the Updike Grain Company withdrew his membership.

Minneapolis.—Mullin & Dillon Company was admitted to the Minneapolis Chamber of Commerce.

New York.—The following have been admitted to the New York Produce Exchange: Simon Kern, of the Bunge North American Grain Corporation; William B. Cassell, of W. B. Cassell & Co.; Bryant M. Gilman, of Alexander W. Herman & Co.; Ferdinand L. Salomon, of F. L. Salomon & Co.; William M. Wolff, of Abrahams, Hoffer & Co.; Roy W. Cowan, of Fitzer & Emmons; Alfred V. Leaman, III, of Richard W. Clark & Co., Inc.; Morris Weis, of Irving Weis & Co.; Edward Gordon, Jr., of the Potter Transportation Company; S. L. Schott, of S. L. Schott & Co., Inc.; B. J. Ferris; Winslow Little, and Isidore Weill.

TERMINAL NOTES

Grain men and millers from all over the country will attend the formal opening of the Chicago Board of Trade on June 9.

The navigation season opened at Chicago last month and a fleet of boats steamed out across Lake Michigan laden with grain for eastern points.

Edward Netre, member of the board of directors of the Baltimore Chamber of Commerce, has been drawn as a member of the May term of the Federal Grand Jury.

M. H. Ladd has been re-appointed chief weigher of the Milwaukee Chamber of Commerce and Allen A. Breed has been re-named chief inspector for the ensuing year.

Statisticians at Oklahoma City have forecast Oklahoma's 1930 wheat crop at 39,700,000 bushels, as compared with the 1929 crop of 44,458,000 bushels, a decrease of 4,758,000 bushels.

President Flanagan of the Milwaukee Chamber of Commerce represented his exchange at the national gathering of the United States Chamber of Commerce in Washington, April 28 to May 1.

Daylight saving went into effect in practically all grain exchanges depending on Chicago quotations, even in cities remaining on standard time, and will continue until the latter part of September.

The Kansas City Board of Trade will award two silver trophies to the winners in the junior and senior divisions of the students' crop judging contest at the Kansas State Agricultural College.

Four all-steel barges and floating elevators, each with a capacity of 50,000 bushels, have been brought to the port of Baltimore by the Pennsylvania Railroad and will be put in service in the near future.

Hearing was opened early in the month in New Orleans on the petition of the Texas and Pacific

railroad and other Louisiana carriers in their attempt to have set aside the decision of the interstate commerce commission in the Texas ports-New Orleans port relationship case.

The new building fund for the Chicago Board of Trade building which will be completed soon had reached \$1,421,667.28 the middle of last month. The membership retirement fund was placed at \$288,687.57.

Chicago stocks of grain in public and private elevators early in the month were as follows: Wheat, 20,354,000 bushels; corn, 3,231,000 bushels; oats, 1,949,000 bushels; rye, 7,088,000 bushels; and barley 305,000 bushels.

The Chicago Board of Trade, like many other exchanges throughout the country, was closed on Good Friday and several members stayed away Saturday and Easter Sunday as well, making it a three-day vacation.

Railways of the Oklahoma and Texas grain belts are making preparations for handling a large grain crop, according to R. W. Edwards, district manager at Galveston of the American Railway Association car service.

Included among the speakers at the thirtieth annual convention of the Western Grain Dealers Association in Des Moines last month was C. Vincent, member of the Omaha Grain Exchange. His subject was, "Orderly Marketing of Grain."

The Chicago Board of Trade has agreed to concede elevator operators the right to install cleaning machinery in public storage houses in order to get the operators to permanently guarantee warehouse receipts calling for specific grades of grain.

Since April 24 the Chicago offices of the Cleveland Grain Company have been located at rooms 1201-03 in the new board of trade building. Other companies are also installed there although the building has not been formally opened yet.

The Fort Worth Grain and Cotton Exchange will move about October 1 to a new building now under construction one block east of the present location. The trading room, inspection department, and laboratory will occupy the entire nineteenth floor.

The internal revenue bureau announced a few days ago that a refund of \$53,017 had been made to John C. Shaffer, grain man and Chicago newspaper publisher, because of an over-assessment on his income tax. Proving that there is a Santa Claus.

W. E. Mullin and L. J. Dillon, two experienced grain men of Minneapolis, will engage in the grain business there as the Mullin & Dillon Company with offices at 914-16, Flour Exchange Building. A general grain business will be conducted, receiving and shipping.

J. C. Ackerman, former vice-president and treasurer of the Midwest Grain Company, has opened offices on the Omaha Grain Exchange. The Midwest Grain Company dissolved by voluntary consent recently when its president, L. L. Quinby, accepted the general managership of the Farmers West Central Grain Co-operation.

Notwithstanding the set-back by the dry spring, southwestern Kansas will have a big wheat crop this year, in the opinion of C. C. Isely, official of the new Dodge City terminal elevator. "We have just passed through the driest five months this section has ever had between November and April and yet our prospects indicate a wheat crop that would have been a record breaker 15 years ago," he said.

The Early & Daniel Company of Cincinnati, Ohio, reports that it is handling more grain at the present time than it ever did in any previous year at the same period. The trade is not buying in large lots, the company states, but it is buying small lots for immediate shipment. The demand is expected to continue as the smaller trade has no supply of grain on hand.

At a meeting held last month, directors of the Chicago Board of Trade declared Rock Island Elevator A irregular because the building is to be demolished by the city of Chicago as a result of

straightening the Chicago River at that point, and the changes in the river have made it no longer possible for vessels of ordinary draft to conveniently approach the elevator.

V. L. Nigh, chief grain inspector of the Fort Worth Grain and Cotton Exchange, sent as a special gift to J. A. Peterson, manager of the Western Maryland Company elevator in Baltimore, a pair of horned toads. The report that the amphibians are ex-members of the Fort Worth exchange has been denied by Mr. Nigh.

R. I. Mansfield, of the Barlett-Frazier Company, Chicago, addressed members of the Toledo Produce Exchange on May 1. He said that the trade will be somewhat upset by farm board activities and the large North American surplus, but the worst is now over and there should be a change for the better within the next 60 days.

The export committee of the Oklahoma City Chamber of Commerce, of which A. J. Zuebieta, export sales manager for the Oklahoma City Mill & Elevator Company, is manager, entertained H. P. MacGowan, United States trade commissioner at Panama City. The purpose was to discuss Oklahoma trade in Central and South American countries.

Three barge loads of wheat, comprising 130,000 bushels, cleared from St. Louis late last month for shipment to New Orleans. This was the first clearance of grain of the 1930 season on the barge line. The shipment consisted of wheat being transferred from the terminal markets of Omaha, Kansas City, and St. Louis to Gulf elevators by the Federal Farm Board.

A car of corn was received at the Kansas City market recently which showed a moisture content of 40 per cent. This is believed to be the highest moisture test shown on any car of corn ever received in that market. The car was shipped from Lebanon, Neb., tested 45 pounds per bushel, was sour and heat damaged, and sold for 40 cents a bushel.

Transactions in wheat futures on the Kansas City Board of Trade, April 22, were 8,257,000 bushels, the second largest day on record, being exceeded only by July 18, 1929, when the total was over 10,000,000 bushels. The large trade was due principally to the purchase of 6,000,000 bushels of cash wheat by the Grain Stabilization Corporation from local elevators.

SPEED AND PRECISION OF ELEVATOR TUBE SYSTEMS WIN PRAISE OF MANAGERS

Unless there is a man around a terminal elevator whose services cost only 20 cents an hour, a pneumatic tube system to carry documents from track level to the headhouse is bound to be a profitable investment. This is a fact that has been demonstrated beyond doubt by tube operation in many modern elevators.

As perfected, the tube system is simplicity itself. Consider, for example, the installations of twin tube systems in the Illinois Central Elevator at Omaha, Neb., the Staley plant at Decatur, Ill., or the Quaker Oats plants at St. Joseph, Mo., and Cedar Rapids, Iowa. A 1 or 2-horsepower motor and blower are all that is required to run these time-savers. The carriers, to hold the tickets, etc., are shot up and down from car dump to weighmaster, at about 40 feet a second—or approximately 25 miles an hour. The tubes are of steel, and will last as long as the elevator itself. Each tube is a "one-way street", so there is no interference in sending with receiving.

The modern type of such apparatus is well illustrated by the installations of the Kelly Cash & Package Carrier Company, Chicago, Ill., the firm which supplied the elevators previously mentioned. M. J. Kelly, who established this business 25 years ago, points out that the vacuum principle in this system practically eliminates the need for repair or overhauling. If a leak develops, the suction

automatically attracts small objects from the surrounding air, and the leak is sealed before it gives any trouble.

The Kelly company, as a rule, has its own engineers install the equipment, and the economy of this procedure is shown by the fact that no complaints ever have been received. R. J. Kelly, son of M. J. Kelly, who founded the concern, has installed several twin tube units for elevators. The business of this firm includes many industries. Its tubes are in almost every type of plant from steel mills to mattress factories.

This concern specializes in furnishing prompt service as to quotations, general plans and installation. Every inquiry gets the consideration of a responsible executive, and each order is followed through to the point where the customer is thoroughly satisfied.

Bearing out these assertions are the statements of the construction engineers and elevator operators dealing with the Kelly concern. They give unqualified endorsement to the Kelly systems in operation at their plants.

Mills as well as elevators have taken advantage of pneumatic messenger service. Tubes may connect the mill laboratory or office with the grinding floor. Horizontal setups are just as efficient as the vertical units.

Inquiries to the Kelly Cash & Package Carrier Company may be made direct to its plant and office at 422 N. Western Avenue, Chicago, Ill.

GROWERS' PROTEST ADDS TO FARM BOARD WORRIES

The Federal Farm Board this month has been accused of discrimination against northwestern wheat growers by the Pullman Grain Growers, Inc., of Washington. The accusations, following closely the action of the United States Chamber of Commerce in denouncing board policies, were contained in telegrams sent to Alexander Legge, board chairman.

Asserting that northwestern wheat producers had been "held up at every stage of the game," the growers asked:

"Why have our people been told they could receive loans on the 1929 crop, basis \$1.13 terminal, until June 30, and why was the date changed to April 30?"

Further, the protest read:

"The wheat growers of the Northwest have been discriminated against. We have been continually advised that all members of the grain growers would be taken care of through federal aid. Ninety per cent of the farmers joined the organization with the distinct understanding that all would receive emergency aid.

"Country bankers carried the farmer under the same assurance. Much of this grain would have been marketed March 1 at higher values than at May 1.

"The action of the farm board in curtailing loans will result in dumping millions of bushels of wheat on the market.

"If the farm board will break its word this early in the game, what assurance have we that they will take care of us in the coming crop that is 60 days away."

NEW CO-OPERATIVE A "MODEL" MARKETING MACHINE

The grain marketing plan of the new million-dollar North Pacific Grain Growers Co-operative Association has been approved by the Federal Farm Board and is looked upon as a model set-up for other grain co-operatives that are to be affiliated with the Farmers National Grain Corporation recently established under the direction of the board. The new association is the outgrowth of a movement started among grain producers of Washington, Oregon, Idaho and western Montana.

The plan of organization calls for a co-operative stock corporation organized under the laws of Delaware. It will have an authorized capital stock of

\$1,000,000 consisting of 50,000 shares at \$20 per share. Stock in the corporation may be sold only to local co-operative elevator, warehouse, or other grain-handling associations on the basis of the average volume handled annually. At the discretion of the board of directors of the North Pacific Grain Growers Co-operative Association, farmers in localities not served by affiliated co-operatives may subscribe directly for the capital stock. These direct stock subscriptions will be transferred to the local association as soon as one affiliated with the regional organization is formed. Each share of stock will have one vote. Then the regional association will subscribe for its pro rata share of the capital stock of the Farmers National Grain Corporation, the big central selling agency with headquarters in Chicago, and will be entitled to nominate and elect directors to serve on the national's board. Where farmer-owned warehouse or elevator associations exist and are not organized co-operatively, assistance will be given to put them in shape to affiliate so they will become eligible to subscribe for stock in the regional association.

TRIPLE-OPTION SALE

As soon as practicable after organization of the regional association, attempt will be made through the local associations to obtain as many signers as possible to the standard marketing contract between the growers and his local association, requiring delivery of the grain to the local association on a triple-option basis. These options are: (1) Sale upon day's price prevailing at time of delivery; (2) deferred sale with storage privileges with a definite time limit, and (3) seasonal pooling basis. The contract will operate for an indefinite period, but provides for a two weeks' annual withdrawal period. Contracts will also be drawn up between each local association and the regional organization requiring delivery of all grain received and a contractual arrangement effected, between the regional and the Farmers National Grain Corporation covering the handling and sale of all grain by the latter.

The local elevator or warehouse association will receive from the regional association, wherever needed, assistance in financing its daily operations in grain and also fixed capital loans. In return the local association will contract to deliver all the grain it receives, either contract grain or purchased grain, to the regional association. The local association will deliver all pooled grain received, and sell all purchased grain received, to the regional association. The regional will deliver all pooled grain to the Farmers National Grain Corporation for sale by the latter. The regional will sell all grain purchased by it from locals to the Farmers National Grain Corporation on the day's market basis.

COUNTRY VERSUS TERMINAL TRADER: IT'S A DRAW

The Fruen Grain Company, Presho, S. D., owes the Boyd-Conlee Company, Spokane, Wash., \$49.24, and Boyd-Conlee owes Fruen \$49.24.

That is the decision of a Grain Feed Dealers National Association arbitration committee (No. 6) after hearing the evidence in the complaint filed by the Dakota firm against the western company. The case arose out of the interpretation of a telegram in which 33 tons of oats were offered by the Fruen company. It was not clear whether the price was 39½ cents a bushel or 39½ dollars per ton.

The committee held that both parties shared in bringing about the misunderstanding. "There is no evidence of careful and explicit wording in the telegram making the quotation," said the arbiters, "and none showing care or a desire to be fully understood in making the wire of acceptance."

The plaintiff placed a net value of \$935.75 on the oats; the defendant valued the same grain at \$837.27, making a difference of \$98.48, half of which was ordered paid to each party by the other. Arbitration costs also were halved between complainant and defendant.

YOU might like to know, first of all, how I came to be in the grain business. It was all due to a chance remark by the late E. E. Doty, then president of Belden & Co., Inc., grain and bean firm of Geneseo, N. Y. He was paying a visit to the elevator in Charlotte, Mich., one of the four Michigan houses operated by his company, and headquarters of my husband, Mr. Flaherty, who then was manager of the trade in the Wolverine State.

At that time Mr. Doty found me assisting in the office, learning the difference between an order-notify and a straight bill of lading, learning that it takes 60 pounds of wheat to make a bushel, while it takes only 32 pounds to make a bushel of oats. I shall never forget the mistakes I used to make. One mistake I recall was in figuring the wheat check for one of Eaton County's prominent farmers. He brought it back the next morning to Mr. Flaherty. He only knew me as the office girl and made a loud complaint to my husband to the effect that "the trouble with these girls was they had their minds on the fellows."

But to get back to the chance remark. Mr. Doty seemed surprised to find me working in the office, looked at me sharply and said, "If anything ever happens to Frank you can run the business." At the time I never expected that prophecy to come true but here I am, and I have been at the grain and bean game on my own for the past four years. So you see I find nothing unusual in a woman being in this business, for I think any woman who found herself similarly situated would have done the same thing.

The one thing I had to be grateful for was that I served the years of apprenticeship and grew up with the business and had the opportunity to be associated with Mr. Flaherty and Mr. Doty, for when Mr. Flaherty suffered a breakdown in 1926 it was up to me to care for Mr. Flaherty and three growing boys, and carry on for Belden & Co. After all, necessity is the best urge to success and I have found that if a woman is willing to put her shoulder to the wheel, men everywhere are willing to assist her. So much for how I happen to be in the business.

And now I assume you want to know my reaction—for plenty of experience is what anybody gets in business. Really, the only excuse for being in business is to make a profit, but the by-product is happiness in achievement or grief in failure. One gets plenty of both so there is little danger of any grain dealer getting that sad affliction, a one-track mind.

Do you know, I have never yet seen a conceited grain dealer? The grain man is constantly aware that powers outside himself determine his fate and this awareness seems to keep him humble.

My first year was the famous wet harvest of 1926 and I had the good fortune to meet Frank Richey, of Dowagiac, Mich. I told him what a novice I was and his practical suggestions and sound advice, so timely given, saved me severe losses that season. Just after the wheat was cut it started to rain and Mr. Richey called me on the telephone early one Monday morning and advised me to get the moisture tester working. It was a timely tip.

You know to operate an elevator nowadays you have to be a specialist and not of the Chic Sale variety either. You must know some chemistry, some mathematics, be a market analyst, a trader, and have a fair knowledge of your fellow man. And combined with these qualifications, you must have plenty of sand. I have found that out.

An elevator is the connecting link between farmer and miller and the problems of one vitally concern the other. I shall come back to that later. I sometimes think we forget the romance of business in concentrating on our cares and our duties. We let our anxieties, particularly in a year such as this has been, overshadow us, and make us forget that business should be a glorious adventure. The distribution of food is the most important thing in the world, according to Jane Addams, and it is an old bromide that bread is the staff of life. Think of the responsibility millers have in making the

A Lady's Experience in Managing Several Elevators Serving Michigan's Grain and Bean Trade

By G. M. FLAHERTY

finest flour to nourish human life; the responsibility we, as grain dealers, have in shipping the finest of graded wheat. When we come to see our responsibility perhaps we can pass on to the farmer the pride he should take in growing only the finest of wheat.

Have you ever noticed the glow of a man's eyes when he runs his fingers through new grain? Midas gazing at his gold felt no more joy than I have seen light up the eyes of men looking at new wheat.

We operate four elevators in Michigan and one of my first resolutions was to earn a reputation for shipping good grain. I think it pays to be a crank

A man-size grain-trade job successfully handled by a woman is an accomplishment that should challenge the attention of a great many he-men dealers who rely on mere masculinity, rather than progressiveness, in the prosecution of their business.

At Charlotte, Chester, Eaton Rapids, and Onondaga, Mich., are located the grain and bean elevators managed by the lady who is author of the material published here. She has proved herself a progressive dealer, not only by the successful conduct of the trade established by her husband, but by her aggressiveness in building up sideline businesses to meet changed conditions. Retail feed lines are merchandised at two of her stations, and an unusual type of gas filling station, run on the Charlotte property, capitalizes its central location.

Far from a boastful attitude is taken by Mrs. Flaherty. She says: "I feared my sex would be a handicap in business when I first took it up. But experience has proved that business men will go out of their way to assist in making successful a woman who shows willingness to play the game according to the rules."

in grading grain and I have trained my assistants to put off-grade wheat where it belongs in a bin by itself and sell and ship it for what it is and not try to get by with a hopper-full of poor stuff by burying it in a carload of good wheat. The hypocrite gets found out speedily in the grain game and there is no permanent place for the "gyp shipper."

I exhibit with pride the fact that in all the grain I have shipped to Toledo I have had but one car misgrade. I was so badly chagrined that I paid that city a visit for I am from Missouri when it comes to a rejection. The Government inspector was most courteous to me and we drove across the city and walked up and down the railroad tracks locating the car. I saw for myself that my elevator man had tried to get away with something. Just one hopper-full of smutty wheat in a beautiful car of white wheat, but what a smacking I took in discount! It might just as well all have been smutty. Which was apropos of one of Mr. Doty's maxims: "Avoid losses and profits will take care of themselves."

So much for grading wheat. Now we come to the meat of the kernel. The grain business is going

through a period of transition and the dealer who recognizes the present problems and looks forward with imagination toward solving them is going to be the one who will remain in business. He must be constantly alert to the fact that any line of business is constantly changing. All he has to do is to keep in step with what is going on and attempt to be one or two jumps ahead.

The staff of life has always been dependent upon a process of evolution. You know the mills of the gods grind slowly but they grind exceedingly fine. And that brings us back to the statement I made that any problem which affects the farmer affects in turn the elevator, the miller, the baker, the store, and lastly the consumer. Any change in the process of any of these steps is passed on to its successor or passed back to its predecessor.

When I first became familiar with the grain business farmers brought their grain to market in a wagon. The marketing was fairly evenly distributed over the year. When the farmer needed money for his taxes or any other necessities he brought a load of wheat to town. Last harvest time in our country the farmer threshed his grain in the fields, rushed it to market in trucks day and night, and swamped storage and railroad facilities. The elevator man did in three weeks what normally would have been a year's business. The present Michigan elevator is not equipped to meet this changing condition.

Hence the operator who is on his toes recognizes this change and is going to make some attempt to meet this changing condition. Mergers seem to be the order of the day and the change may come about in that way. Who knows? Perhaps Mr. Legge does. At any rate we all know that change is a painful process.

The farmer today is a well-informed man. He reads the newspaper, has a radio and automobile and has greatly improved his living conditions. He wears up-to-date clothes. Only one thing remains the same—he is always dissatisfied. But after all, it is the dissatisfied person who gets ahead.

Mr. Doty told me back in 1926, "Mrs. Flaherty, there is just one chance I am taking when I put you in charge of our Michigan business. Will the farmer deal with a woman? I am going to take the chance and bet on you."

The fact that I am still in business proves that farmers will deal with a woman; however, I appreciate the fact that I had an advantage stepping into an established business, for my husband was favorably known to the farmers of our county. I find the farmer is just a human being like the rest of us and that if you are fair in your dealings with him he will stay with you.

One of the most valuable examples on how to get along with folks was unwittingly demonstrated by two of the best-known politicians in our locality, Doc DeFoe, editor of the *Charlotte Republican*, and Frank Green, postmaster at Otivet. The two were dining in our local hotel and I stepped over to speak to them and noted when they gave their orders they specified roast pork and applesauce. Doc added, "Make the applesauce double."

I wish I could recall all the witty remarks farmers have made in my office. I remember one very tall customer, six feet three and a great cigarette smoker. He told me he had smoked since he was only 13 years old, otherwise, he said, he probably would have been quite tall.

Little everyday happenings about a country elevator help to keep life interesting; but if the day gets too dull, Mr. Walton is sure to call up and ask if Mrs. Jesse James is in. Mr. Walton tells me he is collecting money to buy me a horse to complete my outfit. I shall enjoy it, for one should get a kick out of life.

I think it is time to mention those necessary evils, the jobbers. They are my good friends, but I can't resist making them a suggestion. I think they should carry a slogan at the top of their market letters. I suggest Emerson's saying, "Speak what you think today in words as hard as cannon balls and tomorrow speak what tomorrow thinks in hard words again, though it contradict everything you said today."

NEWS LETTERS

MILWAUKEE

C. O. SKINROOD - CORRESPONDENT

CORN trade was the particular bright spot in the grain business at Milwaukee for the past month, the receipts of this commodity soaring to more than 1,040,000 bushels for April as compared with a supply of only approximately 785,000 bushels for the corresponding month of last year. Other coarse grains too, came along with some fair gains in offerings for the past month. Wheat trade, on the other hand, took rather an important slump for the past month with receipts of only approximately 178,000 bushels.

The rate of interest on advances at the Milwaukee Chamber of Commerce for the month of May has again been fixed at 6 per cent. This is the same rate that has prevailed for the last several months. Bankers at Milwaukee report materially easier money conditions in the last few weeks.

A large delegation from Milwaukee went down to Washington to attend the meeting of the Chamber of Commerce of the United States. Among those delegated to go were A. L. Flanagan, the president of the Milwaukee Chamber of Commerce.

One of Milwaukee's best known grain traders for many years is dead—Charles R. Lull at the age of 71. His death took place in Los Angeles. Mr. Lull was born in Troy, Walworth County. He started work as a telegraph operator for the Northwestern Railroad at West Allis and a little later he went into the grain business there. However, by 1893 he had moved into Milwaukee and had become a member of the Milwaukee Chamber of Commerce. He had thus been a member of the grain board for about 37 years.

He was survived by a widow, a daughter, and his son, Raymond, whom he bequeathed a life membership in the Milwaukee Chamber of Commerce.

The Milwaukee Chamber of Commerce is again back on daylight saving schedules in line with the Chicago Board of Trade. While the rest of Milwaukee is still talking about daylight saving, the grain men have taken the bull by the horns and gone on daylight savings basis as usual.

One of the largest estates left in Milwaukee in recent months was that of Christian Kurth, president of the Kurth Malting Company who died on March 6, 1929. The inventory of the estate has just been announced. It shows that the total estate was more than \$1,350,000. The Kurth Malting Company was one of the largest malting concerns in the country.

Frank J. Phelan, one of the leading grain dealers of Milwaukee, who has been operating here for some 20 years and who has a grain concern under his name, has been elected a member of the Chicago Board of Trade. He has purchased a seat on the Chicago exchange, paying \$18,000 for it, according to reports.

Owners of malt, hops and bottle equipment stores are much concerned over the ruling of the United States supreme court that the distribution of such lines is illegal under the Volstead law. This gives the prohibition officials the right to seize any material or any equipment which is intended for brewing. However some Milwaukee dealers in these lines say they have been up against such scares before and that these supplies have many other uses besides those of making illegal beverages. These dealers assert that this is entirely a question of intent and that it cannot be proved that these goods are being sold merely for the sake of producing illegal beverages.

A. L. Flanagan, president of the Milwaukee Chamber of Commerce, came back from the meeting of the United States Chamber of Commerce at Wash-

ington much impressed by the kicks against the farm marketing administration and he believes that congress will have to pay attention to the complaint of the National Chamber. Mr. Flanagan expressed the greatest respect for Alexander Legge and for his ability but he stated that grain market has been so muddled under the farm marketing act that the United States has virtually lost much of its export outlet.

With the opening of navigation many vessels have gone out and this has materially relieved grain storage conditions after the accumulations of the entire winter. The total of grain held has been sharply trimmed down to only about 4,357,000 of bushels and this aggregate is being reduced as each vessel leaves loaded with grain. The holdings of grain at Milwaukee are still very largely oats, the total of this grain being in excess of 2,480,000 bushels.

The Donahue Stratton Company will have space for 2,000,000 more bushels of grain with the addition being built and the Froedtert Grain & Malting Company is also increasing its capacity by 1,500,000 bushels.

Grain stored for manufacturing purposes is subject to local assessment and does not come under the occupational tax law according to a decision of the Wisconsin State Tax Commission. The decision was given as a result of the application of the West Bend Malt Company for a refund in taxes. Grain assessed under the occupational tax law is exempt from state and municipal taxation. The tax commission said that the grain held for future use in manufacturing and not for storage while in transit may be assessed for state and local taxation. The occupational tax law was prompted mainly by the possibility of shipping grain out of the state to avoid taxation.

Elevator operators have received letters from the Federal Farm Board asking if there is any space available here for the storage of grain. No terms were offered. The farm board wanted to know how much space there was available and what price would be asked for it.

Kurtis R. Froedtert, prominent maltster, was injured in an auto accident but recovered promptly.

NEW YORK

C. K. TRAFTON - CORRESPONDENT

FURTHER indication of the growing interest in the securities market on the New York Produce Exchange among dealers in bonds and stocks is furnished by the bulletin board which now bears the applications of five representatives of such concerns wishing to participate in the trading: Irving Sussman, with L. H. Herman; Thomas E. Burns, of Theodore Prince & Co.; Charles W. Seager, of Founders Securities Trust; Milton Deutsch of G. W. Fanning & Co.; and Niel F. Christensen.

The final month of the season of the produce exchange bowling league was featured by a new high score for the year, 246 by H. J. Dahl. Other winners for high actual scores were: Kaiser, 225, and Lee, 222. The same members won the prizes for high gross scores. Other good games were: Therrien, 218; Frey, 216, 214; Rasmus, 214; Galloway, 212; Fritz, 212; Lee, 211; Trafton, 211; McKinney, 206; Brendel, 203; Terry, 201; and Connor, 200.

B. J. Ferris, specialist and commission merchant, was elected to membership in the produce exchange late in April.

The volume of business in the securities market on the produce exchange showed a fair increase during April, the total number of shares being 1,515,703, compared with 1,119,990 during March

and 915,753 during April, 1929. Broadening of interest in the market is indicated by the fact that a new record for the number of different issues traded in, 85, was established on April 25, while on the twenty-third a new record for the volume of bond business was made, \$167,000. When trading was started on December 19, 1928, 207 stocks were listed and this number had increased to 744 by April 30, 1930, while the number of bonds listed increased from 35 to 129. In addition to these issues having been listed for trading, the listing committee has examined available data on more than 10,000 issues. The number of members qualified for trading is now between 150 and 160.

Joseph Seifer, for 16 years an active member of the grain and feed trades on the produce exchange, mostly with B. F. Schwartz & Co., Inc., and predecessor companies, is now associated with L. L. Pinus, grain and feed brokers.

William Barry Cassell, of W. B. Cassell & Co., packing house brokers, was elected to membership in the produce exchange early in May.

Reflecting the inactive state of business generally, the market for tickets of membership in the New York Produce Exchange was very quiet during the past month. Temporarily, the tone was somewhat firmer, but subsequently a slightly easier feeling developed. Early in the period regular tickets sold between \$9,700 and \$10,000, but at a public auction on the exchange floor on May 6 one was bid in at \$8,200. Later bids were reported of \$8,500 with sellers asking \$9,500. Associate memberships sold at \$5,500 and then at \$5,000, and sellers are now asking the higher price with buyers at the lower.

Harold J. Henderson, for the past 10 years connected with the old produce exchange firm of Montgomery & Jenkins and later its successor, Straub & Barry, the last year-and-a-half as a partner, has severed that connection and hereafter will act as solicitor and trader in the grain, oil and securities markets for Coleman & Co.

James D. Norris, assistant treasurer of the Norris Grain Company, on the Chicago Board of Trade, was among the late April visitors on the produce exchange.

As an indication of more general eagerness among investment houses to take part in the securities trading on the local exchange, it was noted that the board of managers admitted eight representatives of such houses to membership last month: Bryant M. Gilman, of Alexander W. Herman & Co.; Ferdinand L. Salomon, of F. L. Salomon & Co.; William M. Wolff, of Abrahams, Hoffer & Co.; Roy W. Cowan, of Fetzer & Emmons; Alfred V. Leaman III, of Richard W. Clarke & Co., Inc.; Morris Weis, of Irving Weis & Co.; Winslow Little, and Isidore Weill.

Edward Gordon, Jr., of the Potter Transportation Company, Inc., ocean transport, who recently resigned his associate membership in the produce exchange, has been elected to regular membership.

As a fitting windup of the season and as a mark of appreciation to those non-members who had assisted in the production of their annual entertainment, the New York Produce Exchange Bowling League gave a shore dinner April 29 at Karatsonyi's Hotel, Glenwood Landing, Long Island. Practically the entire membership attended and enjoyed an excellent repast followed by very interesting professional entertainment. The only speech was a brief announcement of the season's prize-winners by President Lambert which was as follows: High average with handicap—Charles Connor, grain trade trophy and desk set; and second, George B. Schold, traveler's toilet kit. Actual high score—Henry J. Dahl, bridge table and chairs. A similar prize went to John Frey for best average of splits made. Bowling balls were won by A. F. Therrien for best strike average and by A. A. Rasmus for best record of clean games. High score with handicap—H. F. Grothusen, Orr trophy and suit case; and second, W. B. Terry, bottle set. Spare average—R. J. Kaiser, golf clubs. Actual high average—C. K. Trafton, traveling bag. Subsequently the annual meeting

was held at the exchange and all officers were re-elected for another term. They are: President, Charles P. Lambert; vice-president, John Frey; treasurer, A. A. Rasmus; secretary, E. S. Galloway. A motion was passed to appropriate \$25 to purchase a prize to be contested for at the annual spring tournament of the exchange golf association.

The movement to promote sociability and good-fellowship among the members of the produce exchange, especially during their leisure hours, which was given such a strong impetus by the formation of the bowling league five years ago, will be speeded up this month when the baseball game between traders in the securities market and representatives of various commodity lines takes place at the grounds of the Jersey City International League Club on May 17. It is expected that about 200 exchange members and their friends will make the trip to the park in chartered buses which will later take them to the Hermitage in Jersey City for dinner and entertainment. Another event, on May 15, is the annual spring tournament of the golf association at the Wheatley Hills Golf Club, East Williston, Long Island.

S. L. Schott, of S. L. Schott & Co., Inc., was elected to membership in the produce exchange last month.

Simon Kern, of the Bunge North American Grain Corporation, was elected to membership in the produce exchange at the mid-April meeting of the board of managers.

LOUISVILLE

A. W. WILLIAMS - CORRESPONDENT

KENTUCKY has suffered severely through April and May by an unusually prolonged spring drouth, April having been the driest April in more than 40 years, while May hasn't shown any improvement. The farmers have a lot of land plowed, in which they will plant corn, tobacco, late seeds, etc., if rains come and conditions are favorable.

It is reported that the wheat prospects are not nearly so good as they were, as wheat is not developing as it should. Much corn is still unplanted. Shortage of tobacco plants will retard tobacco acreage, a good thing in view of prospects of over production earlier. It has been so dry that farmers have had to haul water to wet down their tobacco seed or plant beds.

It is further reported that the large bluegrass and orchard grass seed growing sections of Kentucky show poor prospects for seed crops this year. Central Kentucky bluegrass cleaners advanced prices \$3 to \$4 per 100 pounds, and then withdrew prices from the market. The new crop is not stripped until mid June.

Wheat has moved from public or private storage to elevators at the grinding mills, and today there is but little wheat paying storage charges to elevator operators.

Distillery business is about through until next fall. Just one plant is now operating, and that one in a limited way, with its run nearing completion.

There has been just a fair demand for corn and oats over the past 30 days. Feed has been in fair demand, but prices are working lower again after having been stronger for a time. Poultry feeds have been especially good; dairy feeds fair; horse feeds fair. Millfeeds have been a trifle scarce due to lack of flour orders, and have commanded good prices. Hominy feed, corn feed meal, alfalfa meal and cottonseed meal have all been in fair movement. Pigeon feed has been normal; hog feed better as a result of less low grade corn available; and sheep feed has been better this spring than usual.

Hay demand has been very slow. Good grades of Timothy, or Light Mixed hay have been fair, but Heavy Clover Mixed, or Clover, along with Alfalfa has been dull. Prices have been firmer due to farmers being busy on the farm, and hauling but little stock.

Egg producers have been quite disgusted with prices paid for fresh eggs this year, loose No. 1 eggs bringing them but 17 or 18 cents, as offerings have been large and storage demand has slumped. Cream producers are also complaining over low prices paid for butterfat. A lot of farmers have been flaying the press and county agents, contend-

ing that the state needs reduced production in poultry, eggs and butter, instead of arguments for an increase.

The Kentucky Public Elevator Company reported very light holdings of grain for customers, with but 20,000 bushels of wheat; 80,000 of corn and 10,000 of oats, or about 1/5 of normally busy season storage.

A lot of seed corn has been sold this year at prices of \$2.25 a bushel and up to jobbers, as but little seed corn was available on the farms.

Frank Flowers is back at the office of Oscar Farmer & Son, after being away over the winter period on account of illness. Mr. Flowers returned to the office shortly after the death of Ed Farmer in the spring. The business is being carried along as usual by the estate.

Joe Marshall, sales manager of the Kentucky Feed & Grain Company, left May 5, for 30 days in the southern territory, principally in Alabama and Georgia districts.

James A. Wallace, feed, grain and coal dealer, also a banker and politician, from Irvine, Ky., was acquitted by a jury in the Franklin Circuit Court, Frankfort, Ky., of altering election returns in a state primary in which he was a candidate some years ago. In 1928 he was convicted and sentenced to 12 years. The Court of Appeals ordered a new trial, in that incompetent testimony was introduced in the original hearing.

The lowly cottonseed hull has been high and scarce, due to late season feeding demand, and the newly developed use of stained or green cottonseed hulls for use as fairways in miniature golf courses. Hulls, which were selling a few weeks ago at \$7 a ton bulk, \$10 sacked; are now \$17 bulk and \$20 sacked.

With the opening of the spring racing season at Louisville on May 10, George Korfhage, Amos Yager, and W. P. Miller, three of the leaders in handling the race track feed demand, found business much more active. Lexington completed its spring meeting just ahead of Louisville.

John R. Watts, seed and grain dealer, operating warehouse and elevator, remarked that things had been very dull, and would remain that way until the weather returned to normal.

E. P. White, Farmers Seed Association, handling seed and feed, on Jefferson Street, near Floyd, on January 1, of this year went on a cash basis, reported much larger business this year than last, and that he wouldn't ever go back to loose credits under any conditions.

H. H. Lewis, of the Lewis Implement & Seed Company, jobbers of feeds, seeds and implements, has been in Florida for several months, and will remain until about June 1.

C. D. Ross, Ross Seed Company, remarked that business was at a standstill, waiting on planting weather, but that there would still be some business on cow peas, soya beans, cane seed, millet and Sudan.

The Ballard & Ballard Mills, Louisville, large producers of a wide line of manufactured feeds, have recently announced an addition to its line in the form of rabbit feed. The company has pigeon, poultry, horse and mule, dairy, sheep, hog, and similar feeds, other than wheat and corn feeds in its line.

J. L. Scobee, for a number of years manager of the Louisville Cottonseed Products Company plant, has been transferred to Macon, Ga., and E. G. Yancey, of Little Rock, has taken charge at Louisville. The Louisville plant is a division of Buckeye, in turn owned by Proctor & Gamble.

J. P. Marshall, father of J. L., and Joe Marshall, of the Kentucky Feed & Grain Company, has been confined to his home for several weeks as a result of being struck by an automobile. For three weeks he was in a hospital. The old gentleman for years came to the plant every day, and took an active part in its management.

The Owensboro Milling Company, Owensboro, Ky., suffered fire loss estimated at \$100,000, with insurance of \$63,000 early the morning of May 9, the elevator, flour mills and a quantity of grain being destroyed. Wilbur Simpson, general manager, attributed the blaze to shorted wires. The elevator plant was closed at six o'clock the previous evening. The flour mill ran until midnight. Mr. Simpson went through the engine room in locking up, and saw nothing to indicate spontaneous combus-

tion. The blaze was discovered at 4:00 o'clock, and by the time the fire department arrived the elevator was a roaring mass of flames. Last December the Owensboro Grain Company plant burned with loss estimated at \$150,000.

OMAHA

B. O. HOLMQUIST - CORRESPONDENT

A TOTAL of \$818.10 was subscribed in the grain exchange building for the Red Cross Relief Fund for victims of the recent tornado at Tekamah, Neb. Of this amount, \$250 was subscribed by the Omaha Grain Exchange, \$106.10 by employes of grain interests and other tenants of the building, and \$463 by individual grain companies.

Applications for membership in the grain exchange have been filed by the Equity Union Grain Company of Kansas City, a farmers' company, and by the Farmers West Central Grain Co-operative, Inc., which is a division of the national set-up of farmers' co-operatives fostered by the Federal Farm Board. C. H. Kenser, formerly of Kansas City, will be manager of the Omaha branch of the Equity Union Company, which will engage in a general commission and merchandizing business. The manager of the Farmers West Central Co-operative is L. L. Quinby, formerly president of the Midwest Grain Company of Omaha. Mr. Quinby has been connected with various Omaha grain firms in the past and his experience in the grain business in this market dates back more than 20 years.

Frank Sorensen, formerly head of the Vincent Grain Company, is now assistant general manager of the Miller Cereal Mills. Mr. Sorensen has been connected with the grain business in Omaha for about 20 years, starting in as bookkeeper for the Beal-Vincent Grain Company, which was succeeded some years ago by the Vincent Grain Company. For the past several years, Mr. Sorensen has headed the company and will continue to retain a financial interest in the company which will be managed by C. N. Ogden.

John C. Ackerman, who was associated with L. L. Quinby in the Mid-west Grain Company, will continue in business under the old firm name. F. P. Liles and T. F. Drummy, former officers of the company, are now in the employ of the Farmers West Central Co-operative.

E. W. Taylor, president of the Nye & Jenks Grain Company, is in Chicago acting in an advisory capacity with the farm board in the matter of appraisal of elevator properties. Mr. Taylor has retained his interests in the local company as it is understood his connection with the farm board is to be only temporary.

Among those from Omaha to attend the convention of the Western Grain Dealers Association at Des Moines on April 28 and 29, were F. H. Hall, A. H. Bewsher, Doyle Hart, H. C. Christiansen, Ray Sage, W. L. Shepard, C. O. Lyle, B. O. Holmquist, and C. Vincent. Mr. Vincent was on the program of the convention, making a very interesting talk on "Orderly Marketing of Grain."

Under the direction of Secretary J. N. Campbell, the Nebraska Grain Dealers Association, is holding a series of meetings in different sections of the state for the purpose of giving information on grain grading and other problems of the country dealers. Up to date, meetings have been well attended by both country dealers and representatives of terminal markets. It is worthy of note that quite a number of farmers have attended these meetings which is evidence of the growing interest on the part of the farmer in problems of marketing and distribution.

The West Coast is still popular as a vacation resort for Omaha grain men. Among those who have returned recently are E. P. Peck, H. R. Clark, J. L. Welsh, J. B. Adams and W. J. Hynes.

E. S. Miller has retired from active management of the Miller Cereal Mills. His son, Max A. Miller, has assumed direction of the company, which is well known as a large manufacturer of corn products, including corn meal, grits, corn flakes, movie "snow," etc.

Reports from all sections of Nebraska indicate that growing conditions the past few weeks have been almost ideal. The early April drouth did very little damage and this has been more than made up for by good rains since. During early May tor-

nadoes have been reported in several sections but damage to crops from this source has been negligible. Wet weather is delaying corn planting at the present writing but there is still ample time for planting in time to assure a matured crop before frost next fall.

* * *

E. L. Cahill, of the Burns Grain Company, left recently on a vacation trip to Excelsior Springs, Mo.

* * *

Stocks of wheat in Omaha terminals are now reported as considerably less than a year ago and this is also true of oats. Corn stocks are still somewhat larger than last year's but are decreasing rapidly as there has been an excellent demand for Nebraska's high-quality corn from all directions.

INDIANAPOLIS
H. M. RUDEAUX CORRESPONDENT

THE movement of grain during April was just about normal, with demand fair from all points east and south. A large portion of grain from this market has been sold to feed manufacturers, and small interior feed mills. The movement of wheat to the Indianapolis market has been heavy for the past 10 or 15 days, and is being stored here. The demand for top grades of corn has been very good, especially corn from southern Illinois points which is of better quality than corn from Indiana points. Oats are dull and without spirit, and the movement has been light although quite sufficient to supply the demand.

* * *

The reports on the wheat crop are optimistic, certain sections report the crop in good shape, with fair to good stand, while other sections report the crop short and stand very poor, with some fields being turned under and prepared for corn. The northern part of the state reports conditions good but acreage short, and in all possibilities the crop as a whole, will be well below normal.

* * *

Indianapolis was represented at the convention of the United States Chamber of Commerce in Washington, D. C., by Otto P. Deluse, president of the Indianapolis Board of Trade; William H. Howard, the board's secretary, and Edward B. Raub, counselor. Mr. Deluse held the proxy of the Illinois Grain Dealers Association and cast its vote at the Washington session.

* * *

The Farmers Grain Company of Carlos, Ind., filed reorganization papers under the name of Farmers Grain Company, of Carlos City, Ind.; objects, buy and sell grain and cereal products. Directors, H. T. Frazier, Otto Gordon, A. C. Engle, R. G. Miller, Harry Miller, U. G. Retter and Clyde L. Gatey.

* * *

Reported consideration of Indianapolis as a location for the headquarters of a branch office of the Farmer's National Grain Corporation, Grain Stabilization Corporation, organized by the Federal Farm Board, has not come to the attention of officers of the Central States Grain Association, one of the affiliated companies, which maintains headquarters in the Indiana Farm Bureau offices. C. E. Huff, president of the corporation, was quoted as saying that five district offices will be established, and that Indianapolis and St. Louis, Mo., are among the locations under consideration.

* * *

O. L. Means, 71, of Acton, Ind., who for many years operated grain elevators at London, Fairland and Brookfield, and a general store at Rossville, died Tuesday, May 6. Burial took place at Acton Cemetery on Thursday. He is survived by the widow, and brother John Means of Pleasant View, Ind.

* * *

The Domestic Feed & Grain Company will move to their new warehouse at 630 South Capitol Avenue, just as soon as repairs and alterations are completed. The company will carry in stock a complete line of all kinds of feeds, flour and remedies. Ed. Logan will be in charge of the new warehouse.

* * *

According to Fred K. Sale, secretary of the National Hay Association, reservations are coming in far better than was anticipated and it looks like the convention which will be held in Columbus, Ohio, July 7-8 at the Deschler-Walick hotel, will go over with a big bang.

* * *

There has been an unusual demand for top grades of hay during April, and prices have gone out of sight. The demand has fallen off considerably in the past 10 days due to southern Alfalfa being

harvested and, from reports the crop is beyond expectations. Feeds have been moving more freely and in larger lots. Mill feeds have been scarce owing to light milling operations, while the demand for all kinds of poultry feeds has been very active. Chick feeds especially are in excellent demand.

* * *

Horace E. Kinney, prominent in grain circles and one of the oldest members of the Indianapolis Board of Trade in point of service, is reported much improved and able to be up and about his room.



HORACE E. KINNEY

Mr. Kinney was stricken with heart disease several weeks ago and has been in a critical condition.

* * *

According to Frank N. Wallace, state entomologist, there will be nothing done to control the corn borer, and farmers will follow the advice that has been given them if they choose to do so. If they are unwilling to co-operate in holding the insect in check, it is likely that the infested area will be larger.

BUFFALO
ELMER M. HILL CORRESPONDENT

OPPPOSITION to the activities of the Federal Farm Board and the principles outlined in the Agricultural Marketing Act are voiced by the Buffalo Corn Exchange in a statement issued by E. E. McConnell, the new president of the organization. The objections are based on the principle of less government in business, and the corn exchange of Buffalo says it will use every effort to see that American business is protected and not interfered with by the Government.

"This exchange stands for American individualism and believes in unrestricted competition in all lines of business," says Mr. McConnell. "We believe in leaving entirely to economics, the elimination of individuals or systems in the marketing of any commodity wherein such individuals and systems are within their moral and legal rights.

"The corn exchange quotes authority in stating that the present recognized system of marketing grain is economically sound, evidence of proof being the many years of its existence without indictment. Today it is recognized as the most complete and successful marketing system in the world."

* * *

Frederick P. Armstrong, president and treasurer of the Whitney-Noyes Seed Company, of Buffalo, is dead. Born in Portland, Maine, in 1871, Mr. Armstrong received his early education in the public schools of that city and moved to Lockport, N. Y., in 1890. He became identified with the Whitney-Noyes Seed Company in 1906 as treasurer of the corporation. Besides his widow, he is survived by three sons and a daughter.

* * *

The first cargo of grain to arrive in Buffalo this year was aboard the steamer *E. M. Bunce*, an ocean-type carrier of the Mid-West Transportation Company which poked its nose behind the breakwater

April 21. The *Bunce* brought 100,000 bushels to be unloaded at the Seneca Elevator. The steamer *Peterson* was the second to arrive and the *Lake Chelan* of the Boland & Cornelius fleet came in third with a cargo of corn for the Monarch Elevator.

* * *

The plant of the Chautauqua Seed Company, near Fredonia, N. Y., was destroyed by fire with a loss of approximately \$15,000, partly covered by insurance. A. E. Lucas is president of the company.

* * *

The Welland Ship Canal connecting lakes Erie and Ontario on the Canadian grain route to Montreal was formally opened April 21.

* * *

Frank A. Worth, credit manager of Spencer Kellogg & Son operating the Kellogg grain elevator, was elected a member of the board of directors of the Credit Association of Western New York at the annual meeting of the organization. Mr. Worth is a former president of the association.

* * *

Thomas C. O'Brien, who for the last five years has been manager of the Abell Forwarding Company, in connection with the Marine A and Marine B elevators, has been appointed vice-president of the Superior Forwarding Company, and general manager of the Superior elevator. Mr. O'Brien, who is the son of Thomas J. O'Brien, president of the Marine Forwarding Company, served his apprenticeship in the grain business at the Husted Milling Company, of Buffalo. He was assistant superintendent of the mill at the time it was destroyed by a dust explosion in July, 1913. Later Mr. O'Brien went to New York as superintendent of the Erie grain elevator at Jersey City and remained in charge of that plant during the period of the war. In 1921 he was transferred to the export department of the Armour Grain Company, on the produce exchange in New York City. He came to Buffalo as assistant manager of the Williamson Forwarding Company and remained with that company until the sale of the Superior Elevator in 1925, when he assumed the management of the Abell Forwarding Company. He is a director of the Buffalo Trap & Field Club and a member of the Genesee Valley Club at Leicester, N. Y.

* * *

George M. Blackmon of Jamestown, who resigned as one of the equity co-receivers for Jay H. Pratt & Co., Inc., seed dealers of Forestville, is succeeded by Royce A. Kelley of Rochester while Mr. Blackmon is retained as counsel for the receivers under an order signed by Federal Judge John R. Hazel at Buffalo. The balance sheet of the company as of March 31 shows total assets of \$113,078 and the net worth of the business was reported to be \$10,605. The court authorized the receivers to continue the business until June 15, 1930. The Associated Seed Growers, Inc., of Chicago is the complainant in the equity action against the Forestville company.

* * *

George F. Sowerby, who for 16 years was president of the Western Elevating Association and former manager of the Niagara elevator, is dead. He was 79 years old. Mr. Sowerby was born in Perry, N. Y., and came to Buffalo in 1884 to act as manager for the Niagara Elevator, a position which he held until the sale of the elevator to the New York Central Railroad in 1900. He was president of the Western Elevating Association for 16 years and also was one of the organizers and a director of the Metropolitan Bank of Buffalo and served as a director of the Third National Bank. He is survived by his widow and a daughter, Mrs. Walter de la Plante.

* * *

Construction at state expense of a grain elevator for operation in conjunction with the municipal pier in the outer harbor at Buffalo has been recommended to the City Council by Frank C. Perkins, president of the council. The state grain elevator, the council president explains, would function along the same lines as the one now in operation at Gowanus Bay, Brooklyn. Supporting the project is Ralph D. Hayes, commissioner of canals and waterways in the New York state department of public works. It was said the canal would help to swell grain traffic over the state barge canal in the event that the Federal Government takes over the Erie and Oswego canals as suggested in administration circles at Washington.

* * *

Lawrence Tremaine of the Hecker H-O Company, was elected a director of the Buffalo Exporters Association at the annual meeting.

* * *

A steady, growing demand for grain in the East is seen in the report of the Buffalo Corn Exchange issued May 5. Close to 1,000,000 bushels of grain were taken from waterfront elevators during the previous week and there likewise has been a steadily increasing movement of grain to the Atlantic seaboard by barge over the New York state canal and also by rail. Storage grain in Buffalo elevators May 5 were 17,779,583 bushels and grain afloat in the harbor at the same time totalled 2,460,161

bushels. Of the grain in elevator storage, Canadian wheat topped the list with 5,766,849 bushels with American wheat second, 5,112,389 bushels. Canadian wheat afloat also topped the list at 1,296,602 bushels.

* * *

Buffalo Elevators, Inc., owners of the Great Eastern elevator, has brought suit in Supreme court at Buffalo against the Wilson Transit Company, and the Great Lakes Transit Corporation, operating steamship fleets on the Great Lakes for \$7,000 damages. The elevator company claims ships owned by the two lake lines damaged an elevator leg and part of the dock along the elevator.

* * *

Denunciation of the Federal Farm Board for alleged undue interference with private business in the grain and feed industry featured the meeting of the Northwestern States Feed Manufacturers Association at the Hotel Buffalo, May 7. Representatives of a large number of feed mills and grain interests were present at the conference called to draft a new form of long term feed contracts.

* * *

The will of Albert G. Jones of Busti, N. Y., who for many years conducted a grain and feed business in that community, has been admitted to probate, revealing an estate valued at upwards of \$40,000. The property is left to a daughter, Fanny Jones.

* * *

Eugene B. Collard, one of Buffalo's prominent feed and grain brokers and member of the Buffalo Corn Exchange, was elected president of the Buffalo Flour Club at the annual meeting of the organization held in the Hotel Buffalo. Mr. Collard succeeds H. E. Tweeden. The Buffalo Flour Club includes in its membership leading feed, flour and grain interests in the Buffalo area. Other officers elected include: E. M. Kain, division freight agent of the Erie Railroad at Buffalo, vice-president; and F. J. Shonhart, assistant manager of the Cargill Grain Company, of Buffalo, secretary and treasurer. Twelve years ago, Mr. Collard entered the feed and grain brokerage business in Buffalo, opening his offices in the Chamber of Commerce Building. Even today Mr. Collard is one of the younger men in the trade. He enjoys a wide acquaintance not only in the Buffalo feed trade but throughout the East.

* * *

Special attention was focused upon loans of the Federal Farm Board to cooperative marketing associations. E. P. Elmore of Oneonta, N. Y., secretary-treasurer of the association complained that the board has loaned the Grange League Federation Exchange \$50,000 with which to establish a system of co-operative marketing. He said this type of loan represented an entirely unwarranted entry of Government in competitive business.

KANSAS CITY

KENNETH FORCE CORRESPONDENT

THE Kansas City Board of Trade on April 15 supported opponents of the railroad consolidation program formulated by the Interstate Commerce Commission. A statement, prepared by R. A. Jeanneret, president of the board of trade here, was filed with the senate committee on interstate commerce in Washington.

The statement called attention to the fact that the Kansas City grain trade had been opposed before to railroad consolidation. It pointed out that last year Kansas City received a total of 97,297 cars of grain. This movement was handled by 12 lines of railroads serving Kansas City.

The Couzens resolution to delay carrying out a consolidation program until congress had been given an opportunity to act was favored by the statement. "Our observation," the statement read, "of the consolidation movement is that in most instances it furnishes an opportunity to the New York bankers and other security handlers to make a profit by readjustment of the securities and that only in a minor number of instances do the consolidations serve, or are they intended to serve, the public interest.

"Every consolidation of carriers that are engaged in competition with each other to any extent whatever is detrimental to the public interest and should be avoided. The shipping public everywhere realizes fully that railroad competition is a thing to be desired and preserved."

* * *

Plans for an extensive campaign for enlarging the membership of the four leading Kansas co-operative grain marketing associations were outlined at Manhattan, May 9, by the advisory committee of the newly formed Kansas-Colorado Grain Warehouse Corporation. The corporation will act

as a regional grain storage agency to function between the individual co-operatives and the Equity Union Grain Company, Farmers Union Jobbing Association, Farmers Co-operative Commission Company, and the Kansas Cooperative Wheat Marketing Association. Due to the late start in the formation of the warehouse organization it is not expected to become a factor in grain storing on the new crop, it was said. Plans for the purchase or building of new grain storage facilities in Kansas are being discussed for the future, however.

* * *

Governor Reed of Kansas has opposed the Federal Farm Board's acreage restriction objective. That restriction should be the very last resort in any program of farm relief, was his contention in a letter to Alexander Legge, chairman of the farm board last month. He pointed out that restriction is not calculated to place agriculture on the same economic basis as industry. He is for the farm board but doesn't approve of its restriction policy.

In a letter to J. C. Mohler, secretary of the Kansas state board of agriculture, the Federal Farm Board chairman, Alexander Legge, hopes personally to present to wheat growers of Kansas his views concerning proposals for a reduction in crop acreage. In his letter to Mr. Mohler, he agrees with the latter's suggestions that the best approach to the problem would be a series of meetings in Kansas throughout the summer months.

* * *

Wallace C. Bagley, of the Updike Grain Company, has sold his membership in the Kansas City Board of Trade and is retiring from the grain business. He has no definite plans for the future, but said he "was getting out of what is left of the grain business." Erich P. Frank of the Uhlmann Grain Company is an applicant for membership in the board of trade on transfer from the Bagley membership, the sale price being \$8,000, including a transfer fee of \$500.

* * *

Vincent O'Dowd, of the Arcady Farms Milling Company, was elected to membership in the Kansas City Board of Trade on transfer of V. E. Combs who recently resigned from the same company.

* * *

Goffe & Carkener, Inc., local grain commission merchants, announce the opening of a branch office at Woodward, Okla. The office there will be connected with the main office here by private wires. The addition of the new branch brings the company's total of branch houses to 10. The company has other branches at Wichita, Hutchinson, Garden City, Hoisington, Salina, Clay Center, and Goodland, Kansas; Hastings, Neb., and St. Joseph, Mo.

* * *

Total transactions in Kansas City wheat futures during April were 75,441,000 bushels; corn, 20,606,000 bushels. A year ago wheat trading amounted to 62,303,000 bushels; corn, 23,787,000 bushels. Open interest in wheat futures average 20,917,000 bushels, which establishes a record. Open interest in corn was 7,696,000 bushels.

* * *

The Rodney Milling Company is excavating for an addition which will double the grain storage capacity of the milling company. The work, which has been just started, will add 250,000 bushels to the grain storage facilities of the company, bringing the total to 500,000 bushels. The company expects to have the new unit completed in two months, which would have it ready for the big summer grain movement. L. S. Myers is vice-president and general manager of the company.

* * *

E. D. Midkiff, assistant engineer of the Purina Mills, May 1 gave an address on "The Operation and Maintenance of Feed Mills" at the Finlay Engineering college here. His talk was one of a series of lectures given students of the school by experienced engineers.

* * *

Harry C. Hensley, for 12 years extension assistant professor of home economics at the University of Missouri, Columbia, is to become senior economist of the fruit and vegetable section of the Federal Farm Board, May 20.

* * *

Howard E. Bagnall, employe of the J. G. Peppard Seed company, has purchased a Monocoupe airplane from Blaine M. Tuxhorn and plans to use the machine in his business.

* * *

Captain Bertrand Rockwell, 25 years ago a grain dealer at Junction City Kansas, died May 15. He established his grain business there following the Civil War in which he fought. He retired 25 years ago and came to Kansas City.

* * *

The Murray elevator, now under lease to the Norris Grain Company, will change hands in June when the lease expires, according to Fred C. Hoose, vice-president and local manager of the Norris company. The elevator was built in 1901 by the Chicago, Burlington & Quincy Railroad, its present owners. It has a capacity of 2,500,000 bushels. The Norris company owns and operates another ele-

vator. Mr. Hoose said that the company might find it necessary to add 1,000,000 bushels of storage room to its own elevator in the near future, but that no definite plans had been made. The Murray elevator now is having its annual weigh-up. At present it contains a little more than 2,250,000 bushels of wheat and a few bushels of barley.

* * *

Louis U. Jeanneret, 71 years old, for 45 years a jeweler in Kansas City and the father of R. A. Jeanneret, president of the Kansas City Board of Trade, died on May 9. Mr. Jeanneret was born in Switzerland and came to this country in 1878 with four brothers.

* * *

One of the missions of the farm board is to educate the public to eat more white bread and therefore consume more wheat, according to Samuel R. McKelvie, who was in Kansas City last month. Americans, he said, are consuming less wheat per capita than 20 years ago. "In opposition to some medical statements, we have the word of the highest medical authorities in the country that white bread is most wholesome," he said. "If we were consuming as much per capita as we were 20 years ago there would be 100,000,000 more bushels consumed."

* * *

Kansas prospects for wheat this year are 135,000,000 bushels, according to the monthly report of the state board of agriculture.

* * *

Farmers living along Mulberry Creek near Salina Kansas, which was flooded during the second week of May, complained that the fish were damaging their wheat crop. One farmer said that a school of carp broke down the plants in many places in his overflowed field. Another farmer threw a club into a field and killed a 19-pound channel cat fish.

BALTIMORE

ROBERT C. NEU CORRESPONDENT

THE Interstate Commerce Commission has denied the petition filed by the Baltimore Chamber of Commerce for a reopening of the Baltimore export and import differential case, in which it was contended that the present differentials do not fully reflect the advantages and economies of the port of Baltimore, as compared with the charges at New York.

* * *

The name of Dudley G. Roe, Jr., of Sudlersville, Md., is posted as an applicant for membership in the Baltimore Chamber of Commerce.

* * *

John J. Frederick, who was for years connected with the export grain firm of Barnes-Jackson Company, of this city, has become associated with the grain commission and forwarding house of Dennis & Co., Inc., one of the best known concerns in this market.

* * *

Blanchard Randell, Jr., former president of the Baltimore Chamber of Commerce, represented this organization at the meetings of the Chamber of Commerce of the United States at Washington, D. C., April 28-30.

* * *

T. Murray Maynadier, chairman of the Grain Committee of the Baltimore Chamber of Commerce, who recently submitted to an operation for the removal of an infected finger, is again regularly looking after his business.

* * *

The following have been named as delegates on behalf of the Baltimore Flour Club to the annual convention of the National Federated Flour Clubs at Chicago, Ill., May 26 and 27: J. Ross Myers, A. W. Mears, and Charles Minnigerode.

* * *

The chartering recently of two British steamers to load full cargoes of wheat at Baltimore would seem to indicate more life to the export situation.

* * *

The sympathy of the trade goes out to Secretary J. B. Hessong, of the Baltimore Chamber of Commerce, whose eldest daughter died on April 22.

* * *

C. Wilmer Watkins, well known in the Baltimore grain and feed trade as head of C. B. Watkins & Co., is at the Maryland General Hospital recovering from injuries sustained in an automobile accident on April 27. Besides cuts and bruises, he suffered a shattered knee cap.

* * *

Recent out-of-town visitors on the floor of the Baltimore Chamber of Commerce were: Oscar Moore, sales manager, Sparks Milling Company, Alton, Ill.; A. F. Hagedorn, of Washington, D. C.;

E. C. Warner, of Chicago, Ill.; J. T. Easson, of New York; Thos. Darby and Lloyd Jones, of Montgomery County, Md.; A. F. Sidebotham, Pacific Coast manager, Furness, Withy & Co., Ltd., of San Francisco, Calif.

* * *

The Pennsylvania Railroad Company has put into service in the Baltimore Harbor four all steel barges and floating elevator, each of 50,000-bushel capacity, for auxiliary service at its export grain elevator at Canton.

* * *

Robert C. Clark, for 48 years in the service of the Baltimore & Ohio Railroad Company, and affectionately known as "Pap," celebrated the sixty-seventh anniversary of his birthday on April 29. Mr. Clark has spent the greater part of his business life in the grain elevator office of the Baltimore & Ohio in the Chamber of Commerce Building, and is therefore known throughout the grain trade. His friends remembered the occasion, and on the morning of his birthday he found his desk covered with boxes of cigars, useful things to wear, and flowers.

* * *

J. A. Peterson, superintendent of the Western Maryland Grain Elevators, this city, received from Chief Grain Inspector V. L. Nigh, of the Fort Worth Grain and Cotton Exchange, on April 24, a pair of live horned toads. In his letter to Mr. Peterson, advising him of the unusual consignment, Mr. Nigh said: "The ground hog scared these toads back into their holes and two Texas cowboys waited for three days and nights for their reappearance. We have trained and domesticated them, and they are now harmless."

* * *

Richard C. Wells, head of the grain, hay and feed house of R. C. Wells & Co., of this city, has recovered from his recent illness, and is again a daily attendant on 'Change here.

* * *

Charles J. Landers, head of C. J. Landers & Co., grain and feed merchants of this market, is confined to his home by a painful carbuncle on his chest.

ST. LOUIS
FAIRMOUNT CORRESPONDENT

ON APRIL 29 the St. Louis Grain Club spent a pleasant afternoon and evening, this being one of its many outings. Many of the members enjoyed golf and the remainder amused themselves in various other sports.

* * *

E. M. Flesh, formerly administrator of the United States Grain Corporation, is a frequent visitor on our floor. Mr. Flesh is a director in the Mississippi Valley Trust Company and has his office there.

* * *

We are pleased to announce that D. T. Moore, who was connected with the J. C. Shaffer Grain Company of this city and Chicago, on April 30 accepted a position with the United States Stabilization Corporation of Chicago. Mr. Moore is well and favorably known on this market, having been buyer for Valier & Spies Milling Company for some time.

* * *

Josh Chilton, an executive of the stabilization corporation of Chicago, was a visitor on the merchants exchange on April 26. Mr. Chilton looks as natural as ever and the membership was glad to see him.

* * *

It is with much regret that we advise that W. Engle, president of the J. H. Teasdale Commission Company has associated himself with the United States Stabilization Corporation of Chicago. We miss Mr. Engle very much.

* * *

It is with regret that we announce the death of W. H. Horton of Memphis, Tenn., the father of Major J. B. Horton of this city and a member of the merchants exchange. Mr. Horton departed this life on April 14, 1930. He was for many years prominent in the grain trade at Memphis, being a member at one time of the firm of Buchanan & Horton of that city. Mr. Horton was 82 years old and had not been active for over a year.

* * *

Carl J. Currie of the Park & Pollard Company of Boston, Mass., is an applicant for membership on transfer from T. F. Maher.

* * *

The following members of the St. Louis Merchants Exchange attended the Illinois Grain Dealers convention at Decatur, on May 6 and 7. They all report having an exceedingly good time and heard many interesting discussions: Frank M. Ward, W. A. Malkemus and wife, Charles A. Wilson, Bert Collins, Oliver H. Schwarz, Ward A. Brown, C. H.

Williamson, Frank B. Waddock, N. P. Nelson, Louis F. Schultz, W. E. Hotchkiss and wife, A. H. Beardsley, S. A. Whitehead, F. J. Sommer, F. H. Barckley, H. L. Bandreau, Edward C. Seele, Claude A. Morton, Benjamin F. Jostes.

* * *

Thomas O'Meara, accountant for the Continental Export Company, accepted a position with the United States Stabilization Corporation on April 26. We regret to see Mr. O'Meara leave St. Louis.

* * *

W. J. Connor, a brother of J. J. Connor, a grain merchant on the Merchants Exchange floor, is now with the United States Stabilization Corporation at Chicago.

* * *

Ollie Wright, accountant for the Marshall Hall Grain Corporation, is temporarily with the United States Stabilization Corporation of Chicago.

* * *

Joe Lamy and A. C. Robinson, former residents of St. Louis and former members of the Merchants Exchange were visitors here on April 12. Both these gentlemen are prominently in the pits at Chicago.

* * *

It is with much pleasure that we mention James M. Adam, manager of the grain and feed department of the Anheuser Busch, Inc., of this city. Our association with Mr. Adam is as a buyer of corn for the Anheuser Busch Corporation on the floor of the St. Louis Merchants Exchange.

Mr. Adam came to St. Louis five years ago as a



JAMES M. ADAM

stranger; many had heard of him as a grain man in Chicago, but none had his personal acquaintance. We find him a friendly, courteous gentleman with quiet dignity and a very pleasant personality. He is affable toward all with much firmness in his business transactions. Jim, as he is known to his friends, seldom can be induced to raise a bid except on a sharp advance in the futures, although he is at all times a large buyer of corn.

Mr. Adam is highly regarded by his St. Louis friends who admire his sterling qualities as a business man. Before coming to St. Louis, Mr. Adam was connected with the Rosenbaum Bros. Grain Company of Chicago, Ill., for 31 years—in fact this was his first business association, starting in with them as a young man. During the war he was an officer in the marines.

Mr. Adam is a Mason affiliated with the Blue Lodge at Oak Park, Ill. He is happily married and has four children, three boys and one girl of which he is duly proud. He is a family man and his greatest pleasure and hobby is his association with his family. He is also a member of the Presbyterian Church.

The St. Louis Merchants Exchange is proud indeed in having Mr. Adam as a member.

* * *

The consolidation of the Hall Milling Company and the Bernet, Craft & Kauffman Milling Company was announced on April 17. The consolidated company will be known as the Commonwealth Flour Mills, Inc., and will act as a holding company for the two mills. The total milling capacity of the consolidated mills will be 5,300 barrels of flour a day, making it one of the largest milling firms in the St. Louis district. The office of the new company is at

340 Planters Building. The new company will have a capitalization of \$2,000,000. The consolidation will involve no change in the personnel or policy. The Hall Milling Company owns a 3,200-barrel mill in East St. Louis, Ill., and has storage capacity of about 750,000 bushels. The Bernet, Craft & Kauffman Milling Company owns a 2,100-barrel mill at Mt. Carmel, Ill., with storage space of 400,000 bushels. The officers of the new company are P. M. Marshall, president; A. E. Bernet, first vice-president; R. M. Walker, A. C. Bernet and P. S. Wilson, vice-presidents; F. H. Bernet, secretary and H. A. Berkemeyer, treasurer.

GRAIN NEWS FROM BOSTON

By L. C. BREED

C. C. Lewis, president of Lewis Grain Corporation of Buffalo, and former head of the Buffalo Corn Exchange, recently was a visitor to the exchange.

* * *

Business was suspended on the Boston Grain and Flour Exchange in the observance of Good Friday, and very little trading was done on Saturday which was a local holiday in the celebration of the anniversary of the battle of Lexington.

* * *

Arthur T. Safford of Safford & Smith and Harry Taylor, both of whom are well known members of the Exchange, recently returned home from the South by automobile.

* * *

The third annual exhibition of paintings by members of the Business Men's Art Club of Boston, recently was held at the Boston Art Club. Among the artists displaying their work was Charles M. Cox of C. M. Cox Company.

* * *

St. Louis quotations on future trading in bran and standard middlings are being shown on a special board at the Exchange. They are received by special wire and transactions are taking place, the volume of which is expected to gradually increase.

* * *

Stanley E. Newton of the Sennot Grain Company, with offices in the Exchange building, and who was a member of the Boston Grain and Flour Exchange, was found dead beside his automobile in a garage. He evidently was the victim of carbon monoxide poisoning. He resided in Lynn and his funeral took place April 8.

* * *

The Berkshire Farmers Exchange, Inc., of Pittsfield, Mass., has been incorporated. Edgar A. French of Boston is president.

* * *

Torrence Vary Company, Lynn, Mass., has been incorporated to deal in flour, grain, hay, etc. The capital stock is 700 shares without par value. Frederick W. Spearin, president, Fred C. Spearin, treasurer.

* * *

The movement that is underway to bring about an increase in the terminal facilities of the port of Boston, is gaining much attention. Recently Frank S. Davis, manager of the Maritime Association of the Boston Chamber of Commerce, and Mayor James M. Curley appeared before the Ways and Means Committee of the Massachusetts Legislature in support of the proposal to erect a grain elevator on state-owned land in South Boston.

* * *

Several business organizations in New England are co-operating in calling the All-New England Export Conference to be held under direction of the New England Council in Boston, May 14.

* * *

Owing to favorable weather conditions, the business of the Boston seed dealers is very active, and they have been obliged to prolong working hours in order to handle their trade.

* * *

Boston wholesale grain dealers state that trade for April in grain reached in volume that of an average month in spring though it was so to speak, a hand-to-mouth sort, the retailers preferring to buy little and buy often. In feed, however, business did not reach the average volume, mainly because the mild weather admitted of farmers putting their cows to pasture to a considerable extent. The price of feed declined for awhile and then took an upward turn. Large shipments of mill feed continue to arrive from Argentina. There is very little Canadian bran and middlings being offered. There is a steady demand for chicken wheat, the price of which is lower than other kinds of feedstuffs.

* * *

The receipts of hay at Boston during the month of April were 110 cars. Straw, 4 cars. Though trade is not active, the small receipts render prices firm. Shipments of hay from Canada, through-billed to England, continue to arrive.

* * *

Receipts of grain at Boston during the month of April, as tabulated by the Boston Grain and Flour Exchange, were as follows: Corn, 1,250 bushels; oats, 34,400 bushels; rye, 1,100 bushels; barley, 400

bushels; malt, 5,265 bushels; mill feed, 1,541 tons; corn meal, 822 barrels; oatmeal, 14,846 cases and 430 sacks.

* * *

Stocks of grain in regular elevators as of April 26, were as follows: Wheat, 1,717,436 bushels; oats, 4,506 bushels; rye, 1,280 bushels.

* * *

During April the following export shipments were made: Oatmeal to London, 8,085 cases; Liverpool, 2,600 cases. Hay to London, 727 bales; Liverpool, 854 bales.

* * *

Among the visitors to the Exchange during the month of April, outside of New England, were the following: C. C. Lewis, Buffalo, N. Y.; Leo G. Burke, New York City; C. B. Dreyer, St. Louis, Mo.; C. S. Woolman, Chicago, Ill.; W. H. Buott, Seattle, Wash.; E. Furgeon, Montreal, Canada; George E. Roberts, Chicago, Ill.; J. B. Stouten, Buffalo, N. Y.; J. A. Lenz, New York City; Frank G. Ely, Chicago, Ill.; B. H. Hill, Chicago, Ill.

FELIX J. WELLER DIES

Funeral services for the late Felix J. Weller, former president of the Weller Manufacturing company, Chicago, Ill., have been arranged for Saturday, May 17. Mr. Weller died May 10, at Riverside, Calif., where his body was cremated. The ashes are being brought to Chicago for burial at the Rose Hill Cemetery.

The deceased was one of the two Weller brothers who established the Weller company and for many years acted as its chief executives. The brother of the late Felix J. Weller died several years ago. Both of the men were widely known in the grain trade and milling industries.

LARGE PART OF POOR WHEAT IS GOVERNMENT OWNED

A considerable amount of the 1,247,000 bushels of wheat in Chicago elevators, which the South Chicago Elevator Company, a subsidiary of the J. C. Shaffer Grain Company, announced in April as being out of condition, is Government owned, according to a statement issued by officials of the Grain Stabilization Corporation.

The announcement came as a result of an investigation into the condition of wheat in storage at Chicago by a committee of leading bankers who are holding notes on the grain as collateral. Rumors also continued to circulate that other grain in storage might be deteriorating with warm weather approaching to give added alarm to the possibilities of heating.

John Stream, an official of the Shaffer Company, stated that the grain in question was not seriously damaged but that the notice had been given of its condition as a protection to his concern which was to be visited by the investigating committee soon. It served as a warning, he said, that the holders of receipts on the grain were responsible for its condition which had come about through no fault of the warehouse management.

REGISTERED SEED IN CANADA'S GRAIN TRADE

Due largely to the efforts of the Canadian Seed Growers' Association (according to the claims of that organization's friends), good reliable seed is perhaps more readily available at the present time than has been the case of any time in the past. This association made up entirely of growers has had as its objective, for a period of 25 years, the building up of reliable seed stocks of standard varieties, and the production of this seed in quantities sufficient to meet the popular demand. Seed that comes up to the requirements of Canadian Seed Growers Association, and bearing a government seal is known as registered seed. Such seed is pure as to variety to the extent of 99.9 per cent, and furthermore is practically free from weed seeds and seeds of other kinds of grain.

The establishment of both large and small seed cleaning centers in some sections of the country, centralizes the cleaning and marketing of large quantities of registered seed, and supplies another

medium through which high quality seed can be obtained.

When the purchaser is not prepared to pay the comparatively small difference in price between registered seed and ordinary seed, it is sometimes possible to locate seed that traces back to registered seed. When this is done, however, there is entirely no guarantee regarding the purity and quality in general of this stock, but it is often the case that this seed may be better than ordinary seed.

High quality seed of the registered grades can therefore be purchased either from the growers or from reliable seedsmen in Canada, who usually carry large stocks of this seed representing the standard varieties recognized by the Canadian Seed Growers' Association.

SOVIET SEED SHORTAGE

The number of co-operative farms, tributary to the 100 per cent co-operative marketing system in Russia, is growing like a snowball, according to Carroll Binder, Moscow correspondent of the *Chicago Daily News*. This month the number of kolhoses, collective organizations, is 63,000. Only 56,000 by April 15 were predicted in official estimates.

"Meantime," cabled this correspondent during the second week of the month, "economists are preoccupied with the problem of finding seed and other supplies for the kolhoses. About 90,000,000 acres have been cultivated, but the state has supplies on hand for less than 60,000,000. Only 24 per cent of the seed sought had been collected by February 1."

GRAIN WORLD

DURANGO'S RECEIPTS AND SHIPMENTS

According to the most reliable estimates, the corn harvest in the Durango district of Mexico was less than 40 per cent of normal this year, the Department of Commerce is informed in a report from Vice-consul Ellis A. Bonnet. Although native corn is preferred for food, only a small premium will be paid and merchants declare that it is possible to sell American corn in Durango for slightly over \$100 (pesos) per metric ton (about \$1.35 per bushel). Durango corn is now selling in Torreon for around that price and is approaching that price in Durango, but it is not expected to go much beyond that limit, except for possible short flurries.

Six cars of corn were received in Durango during the quarter ended December 31, and 28 cars were shipped from that city during the same period; some corn is produced in the immediate vicinity of Durango, and loaded at the station, but the foregoing figures indicate that reeserve stocks held over from last year have been expended while prices were high. Ample corn was held for local consumption.

NEW ELEVATOR CHARGES

Assistant Trade Commissioner Clark at Johannesburg, Union of South Africa, reports that the Durban Chamber of Commerce has been recently notified that, with the beginning of the 1930-31 maize season, the following elevator charges will be in effect:

Maize deposited from the beginning of the season up to September 30: 10 days free storage; 2d. per 200 pounds for the next 40 days or part thereof; and thereafter 2d. per 200 pounds for every 10 days or part thereof up to 120 days. For a period in excess of 120 days, 1d. per 200 pounds for every 30 days or part thereof.

Maize deposited from October 1 to May 31: 10 days free storage; 2d. per 200 pounds for the following 40 days or part thereof; thereafter ½d. per 200 pounds for every 10 days or part thereof up to May 31. Previous season's maize will continue to be charged for as heretofore.

Effective May 1, 1930, harbor shed storage charges for bagged grain and grain products, for export, are to be revised as follows: Ten days free; then 2½d. per 2,000 pounds for 10 days or part thereof for the next 40 days; thereafter 3d per ton.

IN "MAIN STREET'S" HOME TOWN

By H. W. JEFFRIES

Sauk Center is said by those who claim to know to be the town Sinclair Lewis had in mind when he wrote "Main Street," that best seller of a few seasons ago. Long before Mr. Lewis had any idea of making the principal street in this town famous and the most talked of thoroughfare in the country, Charles H. Eyler had been operating an elevator and feed business there. While Mr. Lewis was grinding out his observations on small town life, Mr. Eyler was busy grinding feeds for his trade.

His property consists of two buildings, both of



CHARLES H. EYLER'S ELEVATOR, SAUK CENTER, MINN.

frame construction. The usual type of chemical hand extinguisher is used for fire protection although his location right near the Great Northern depot is such that a prompt response can be had from the local fire department in case of need. The elevator measures approximately 40 by 50 feet with a height of 40 feet. Near this is a combination warehouse and feed mill, in which a Munson Mill is located. This well known grinder uses two electric motors of 25 horsepower; which are direct connected to it. A smaller motor supplies power for the elevating machinery.

All grinding is done on a custom basis. Farmers for many miles around come in on the splendid highways found here to have their oats, corn and barley ground. Mr. Eyler is assisted by two employes, one of whom is in charge of the elevator and the other in charge of the grinding. Both coal and wood, as well as flour, are handled as sidelines



WAREHOUSE AND FEED MILL OF CHARLES H. EYLER

and two brands of the latter are stocked. These are Pillsbury's "Best" and Ervin's "Best," the last named brand being made in the nearby town of St. Cloud. Fairbanks, Morse & Co., Chicago, supplied a wagon scale, which is located between the two buildings.

IMPORTATION and transit of wheat and wheat flour in Belgium are made subject to a special authorization to be delivered by the Belgian Minister of Agriculture and the Minister of Industry and Labor, according to royal decree, published in the *Moniteur Belge*.

CORN is, next to wheat, the most important field crop in Hungary. The increased preponderance of peasant farming in Hungarian agriculture has tended to stimulate corn production, but on account of the precarious climate yields fluctuate widely. It is probable that disappearance of corn in Hungary will tend to increase in response to the demands of a growing animal industry.

THE AMERICAN ELEVATOR AND GRAIN TRADE

May 15, 1930

677

APRIL RECEIPTS AND SHIPMENTS

BALTIMORE—Reported by James B. Hessong, secretary of the chamber of commerce:

	Receipts		Shipments	
	1930	1929	1930	1929
Wheat, bus.	546,135	765,158	1,378,675	1,523,147
Corn, bus.	57,720	77,906	86,837	86,837
Oats, bus.	62,003	130,638	69,895	69,895
Barley, bus.	3,573	576,556	838,530	838,530
Rye, bus.	4,170	1,156
Malt, bus.	43,355	37,466	8,090
Mill feed, tons	803	921
Hay, tons	122	36
Flour, bbls.	63,384	67,703	8,507	7,590

CHICAGO—Reported by Lyman West, statistician of the board of trade:

	Receipts		Shipments	
	1930	1929	1930	1929
Wheat, bus.	863,000	1,141,000	1,230,000	797,000
Corn, bus.	6,886,000	4,901,000	4,318,000	5,842,000
Oats, bus.	1,986,000	2,022,000	1,944,000	2,248,000
Barley, bus.	389,000	612,000	193,000	242,000
Rye, bus.	4,000	306,000	695,000	11,000
Timothy Seed, lbs.	926,000	471,000	1,160,000	778,000
Clover Seed, lbs.	1,112,000	959,000	494,000	484,000
Other Grass, Seed, lbs.	1,349,000	1,111,000	1,112,000	1,246,000
Flaxseed, bus.	15,000	19,000	14,000
Hay, tons	5,325	7,224	1,166	778
Flour, bbls.	918,000	980,000	499,000	512,000

CINCINNATI—Reported by J. A. Hallam, chief inspector of the board of trade:

	Receipts		Shipments	
	1930	1929	1930	1929
Wheat, bus.	166,400	119,000	221,200	161,000
Corn, bus.	471,000	432,000	424,500	431,200
Oats, bus.	320,000	144,000	214,000	150,000
Barley, bus.	6,400	11,200	4,800
Rye, bus.	1,400	1,400	7,000	4,200
Grain sorghums	1,400	1,400
Mill feed, tons	300	330
Hay, tons	6,451	9,174

DENVER—Reported by H. G. Mundhenk, secretary of the grain exchange:

	Receipts		Shipments	
	1930	1929	1930	1929
Wheat, cars.	186	178	24	21
Corn, cars	467	517	197	157
Oats, cars	22	51	5	9
Barley, cars.	23	34	1	6
Grain sorghum, cars.	3	3
Beans, cars.	179	97	59	42
Hay, cars	75	97

DULUTH—Reported by Charles F. MacDonald, secretary of the board of trade:

	Receipts		Shipments	
	1930	1929	1930	1929
Wheat, bus.	1,445,637	3,464,634	701,335	6,197,670
Corn, bus.	20,624	16,660	559,799
Oats, bus.	9,351	51,970	3,000	349,248
Barley, bus.	42,444	417,554	118,000	1,299,841
Rye, bus.	39,285	243,826	3,160	515,382
Flaxseed, bus.	3,438	21,436	4,150	47,852
Flour, bbls.	147,020	295,865	76,870	217,600

FORT WILLIAM, ONT.—Reported by E. A. Ursell, statistician of the board of grain commissioners:

	Receipts		Shipments	
	1930	1929	1930	1929
Wheat, bus.	1,595,845	9,690,838	1,958,781	17,126,640
Corn, bus.	4,843	3,115	7,445	3,115
Oats, bus.	386,726	2,971,297	275,179	3,173,035
Barley, bus.	142,174	1,679,931	407,396	3,370,451
Rye, bus.	69,259	394,407	353,028
Flaxseed, bus.	24,198	31,913	25,548	173,379
Mixed grain, 50 lb. bus.	11,522	108,413	141,647	25,120

GALVESTON—Reported by George E. Edwardson, chief of the cotton exchange and board of trade:

	Receipts		Shipments	
	1930	1929	1930	1929
Wheat, bus.	313,788	501,617
Corn, bus.	98,341
Barley, bus.	53,000
Kaffir corn, bus.	4,285	169,307

HOUSTON—Reported by W. J. Peterson, chief grain inspector and weighmaster of the merchants' exchange:

	Receipts		Shipments	
	1930	1929	1930	1929
Wheat, bus.	278,221	80,000

INDIANAPOLIS—Reported by William H. Howard, secretary of the board of trade:

	Receipts		Shipments	
	1930	1929	1930	1929
Wheat, bus.	212,000	114,000	234,000	87,000
Corn, bus.	2,008,500	1,230,000	1,540,500	1,123,500
Oats, bus.	1,236,000	894,000	1,172,000	1,004,000
Barley, bus.	1,500	1,500	6,000
Rye, bus.	3,000	3,000
Flour, bbls.	44,872	37,127

KANSAS CITY—Reported by W. R. Scott, secretary of the board of trade:

	Receipts		Shipments	
	1930	1929	1930	1929
Wheat, bus.	4,300,830	2,475,540	2,321,420	3,024,700
Corn, bus.	2,763,000	2,191,500	2,479,500	2,070,000
Oats, bus.	864,000	348,000	618,000	206,000
Barley, bus.	110,400	59,200	96,000	17,600
Rye, bus.	9,000	25,500	6,000	9,000
Kaffir-Milo corn, bus.	295,900	425,700	116,000	336,000
Hay, tons	16,260	14,292	9,972	8,172
Flour, bbls.	45,825	42,900	770,100	672,475

LOS ANGELES—Reported by M. D. Thiebaud, secretary of the grain exchange:

	Receipts		Shipments	
	1930	1929	1930	1929
Wheat, cars.	236	241
Corn, cars	300	258
Oats, cars	27	9
Barley, cars.	152	78
Cereal, cars.	65	67
Beans, cars.	16	14
Rice, cars	65	54
Cottonseed, cars	42	39
Linseed, cars.	29	18
Kaffir corn, cars	32	83
Hay, tons	53	488

MILWAUKEE—Reported by H. A. Plumb, secretary of the chamber of commerce:

	Receipts		Shipments	
	1930	1929	1930	1929
Wheat, bus.	178,640	334,480	153,067	162,250
Corn, bus.	1,040,440	785,880	1,340,988	1,119,500
Oats, bus.	561,720	354,570	1,209,720	839,611
Barley, bus.	719,325	808,800	212,350	246,960
Rye, bus.	14,000	26,750	9,150	20,440
Timothy seed, lbs.	93,550	30,000	389,780	210,635
Clover seed, bus.	158,660	261,290	1,321,470	1,207,175
Mill feed, tons	40	2,120	9,440	7,510
Flaxseed, bus.	858	118,714	1,430	10,010
Malt, bus.	15,200	17,100	342,000	304,000
Hay, tons	72	396
Flour, bbls.	94,850	175,700	5,600

MINNEAPOLIS—Reported by G. W. Maschke, statistician of the chamber of commerce:

	Receipts		Shipments	
	1930	1929	1930	1929
Wheat, bus.	4,449,530	5,529,670	2,856,440	3,217,820
Corn, bus.	916,490	276,830	762,060	689,290
Oats, bus.	908,570	1,521,230	1,889,250	1,156,500
Barley, bus.	1,238,450	1,107,940	1,101,950	1,254,890
Rye, bus.	459,890	417,600	336,660	236,330
Flaxseed, bus.	132,570	254,780	146,230	167,590
Hay, tons	1,316	1,335	394	248
Flour, bbls.	22,908	19,857	990,207	879,711

MONTREAL—For February and March receipts and shipments, see terminal markets section.

NEW ORLEANS—Reported by S. P. Fears, chief grain inspector and weighmaster of the board of trade:

	Receipts		Shipments	
	1930	1929	1930	1929
Wheat, cars	7	44	585,236	304,124
Corn	29	97	14,228	567,393
Oats	26	71	17,148	70,806
Barley	6	65,000	17,660
Rye	1

RIVER BARGE RECEIPTS

	1930	1929
Wheat, bus.	4,997
Corn, bus.	31,756	144,531
Oats, bus.	10,001	15,031

NEW YORK CITY—Reported by H. Heinzer, statistician of the produce exchange:

	Receipts		Shipments	
	1930	1929	1930	1929
Wheat, bus.	2,206,300	3,011,600	4,966,000	3,184,000
Corn, bus.	135,000	100,500	8,000
Oats, bus.	178,200	472,000	40,000	40,000
Barley, bus.	13,600	1,018,200	83,000	1,298,000
Rye, bus.	25,500	72,000	34,000	61,000
Clover seed, bags	335	2,380	1,710
Flaxseed, bus.	24,000	255,500
Hay, tons	2,825	1,813
Flour, bbls.	1,276,106	1,308,850	380,000	422,000

OMAHA—Reported by F. P. Manchester, secretary of the grain exchange:

	Receipts		Shipments	
	1930	1929	1930	1929
Wheat, bus.	979,200	732,800	2,529,800	842,800
Corn, bus.	2,284,800	679,000	3,001,600	1,321,600
Oats, bus.	742,000	576,000	904,000	766,000
Barley, bus.	4,200	21,000	2,800	37,800
Rye, bus.	48,000	28,800	48,000	46,400

PEORIA—Reported by J. R. Lofgren, secretary of the board of trade:

	Receipts		Shipments	
	1930	1929	1930	1929
Wheat, bus.	81,600	103,200	80,400	112,800
Corn, bus.	2,036,100	1,488,450	1,098,550	621,150
Oats, bus.	512,600	421,400	612,000	400,200
Barley, bus.	359,800	218,400	91,000	50,400
Rye, bus.	1,200	2,400
Mill feed, tons	29,410	27,700	48,230	48,160
Flour, bbls.	209,595	242,800	192,700	217,600

PHILADELPHIA—Reported by L. J. Riley, assistant secretary of the commercial exchange:

North American overseas shipments have been running only a little over half as large as last season. Shipments during the first week in May, however, were the largest since early in the season, according to trade figures. Export sales, as reported by the trade, are averaging around 3,000,000 to 4,000,000 bushels a week, which would indicate continued small weekly exports. Southern Hemisphere shipments continue of moderate volume with 2,465,000 bushels reported shipped from Argentina and 1,904,000 from Australia during the first week in May. Small amounts are still being shipped from Russia and Black Sea ports. European port stocks at the first of May were of moderate volume, stocks in Continental ports amounting to about 3,600,000 bushels and United Kingdom stocks to about 10,000,000 bushels.

United States wheat is still meeting active competition from other foreign wheats in European markets. United States and Argentine wheats were being quoted at practically the same price in English markets May 9 with 62½ pound Rosa Fe reported offered at London May 9 at \$1.13½ and No. 2 Hard Winter at Liverpool at the same price, both for May shipment. Western Australian wheat sold at London during the week at \$1.21½ and No. 1 Canadian Manitoba at \$1.22¾ per bushel. French wheat was reported sold c.i.f. England, Holland and Italy at around 98 cents per bushel. Native wheat was quoted at Paris at \$1.23½, German wheat at Hamburg at \$1.96⅞ and native Durum wheat at Naples at \$2.09⅝ per bushel.

CASH WHEAT FIRMER

Domestic cash wheat markets have held materially firmer than futures during the past month with good mill demand absorbing the light current arrivals. Prices of Hard Winter wheat are below \$1 per bushel in the principal markets, No. 2 Hard Winter ordinary protein being quoted at Kansas City May 9 at 95-95½ cents per bushel. A premium of one cent per bushel was being paid for each ½ per cent protein above 12 per cent. Relatively larger premiums are being paid for Soft Winter wheat than for Hard Winters, reflecting the small supplies of this class of wheat of good milling quality. No. 2 Soft Red Winter wheat was selling May 9 at St. Louis at \$1.10-1.13 and at Cincinnati at \$1.09½ per bushel.

Cash Spring wheat markets were independently firm with 12 per cent protein No. 1 Dark Northern quoted May 9 at Minneapolis at two cents to five cents over the July price of \$1.01⅞. Durum wheat is also selling at steady prices at this writing with No. 1 Amber quoted at Duluth May 9 at 94-97 cents per bushel. Canadian cash wheat markets have strengthened along with the domestic markets and No. 1 Manitoba Northern was quoted May 9 at Winnipeg at \$1.05⅞ per bushel. Pacific Coast markets continued weak and the lowest price of the season to date was reached at Portland, Oregon, on May 8, when wheat for May delivery was quoted at \$1.00½. The slow export inquiry and limited domestic outlet have been principally responsible for the weakness in the wheat markets in that territory.

FEED GRAINS LOWER WITH WHEAT

Feed grain prices declined with wheat during the past month but the loss was less pronounced, because of the strengthening influence of relatively light offerings and a continued active demand. Supplies of both corn and oats are well below those of a year ago. Farm stocks of corn at the first of May, according to private trade estimates, were 40 to 45 million bushels smaller than a year ago and about the same as at the first of May two years ago. Market stocks were also smaller. Farm supplies of oats were around 50,000,000 bushels below those of a year ago but about 30,000,000 bushels larger than the small stocks on farms May 1 two years ago. Market stocks of oats, however, are about 5,000,000 bushels larger than at this time last season.

Corn was bringing five cents to six cents per bushel less at the principal markets May 9 than a month ago but there was an active demand from feeders, industries and shippers which absorbed the current offerings and took some grain out of storage stocks. No. 3 Mixed corn was selling at Chicago

May 9 at 77¼ cents, at Kansas City at 73-74½ cents, and at Minneapolis at 68½-70½ cents. No. 3 Yellow was bringing 78¼-79½ cents at Chicago, 76½-78 cents at Kansas City and 74½-79½ cents at Minneapolis. Oats prices declined three cents to four cents during the month and No. 3 White were selling May 9 at 40¼-41½ cents at Chicago, 36½-37¾ cents at Minneapolis and 41-41½ cents at Kansas City.

Domestic barley markets have shown very little change during the past month. Malting grades have been readily taken in central western markets and feed grades have been in fair request. Market stocks were reduced about a million bushels during the month and on May 3 were about the same as a year ago. Domestic buyers have been taking practically all of the offerings as export demand for United States barley has been negligible except for certain California grown barleys.

ANOTHER CONFERENCE IN PROSPECT

The resolution asking for the repeal or amendment of the Agricultural Marketing Act, which originated with the Minneapolis Chamber of Commerce and was endorsed by the grain exchanges of Chicago, Duluth, Kansas City, Omaha, Buffalo and others, was introduced at the recent meeting of the United States Chamber of Commerce at Washington, and started some fireworks.

Alexander Legge of the farm board and Secretary of Agriculture Hyde defended the act stoutly, but the chamber passed the following resolution:

We reaffirm the earlier declaration of the Chamber of Commerce of the United States made through referendum vote of its membership upon a carefully matured report of a representative committee, in supporting the principle that the producers of agricultural commodities should have the benefits which cooperative marketing of their product along sound economic lines can confer; in pointing out that all agricultural credit requirements could not be met by full employment and adoption of existing credit facilities to local and commodity needs, rather than by the creation of new credit facilities; and in advocating a federal farm board to assist agricultural producers and their organizations in solving the problems peculiar to agriculture.

The legislation which was enacted in June, 1929, was in contravention of the chamber's proposals in its provision of new credit facilities in the form of large sums of money from the public treasury to be used under the Act as the farm board might decide. During the business crisis of some magnitude which has occurred during the last six months these funds have been brought into use in various ways.

We recognize the emergency considerations which may have impelled this resort to the Federal treasury, but the experience which has been gained now permits an appraisal both as to immediate effect and long-range results.

The anticipated benefits to the farming interest as a whole had not been realized. On the contrary there has been impairment of the marketing structure and prevention of support which otherwise would have been given to the marketing of agricultural products which were affected by the use of public monies. Without benefit to agriculture there has been imposed unbearable hardship upon business enterprises unable to maintain their position against discriminatory competition from the Government.

We accordingly express our continued opposition to the use of Government funds in providing capital for the operation of agricultural cooperatives, and for the buying and selling of commodities for the purpose of attempted stabilization. We condemn as a policy of government the employment of public funds for the purpose of participation in business in competition with established agencies and support the proposal for an amendment of the Agricultural Marketing Act to repeal the authority of the Federal Farm Board to use Federal funds for such a purpose.

We advocate the continuance of the Federal Farm Board as a proper agency, conducted at Federal expense, for the gathering and circulation of authoritative information, for ascertaining conditions of overproduction, for advice as to its prevention, and for assistance toward the solution of the numerous and important business problems affecting agriculture both in production and in marketing.

We believe it is desirable to apply sober and devoted study to methods by which co-operative organizations on their resources may find their warranted place, without the present danger of undermining marketing facilities and thus unfavorably affecting farm prices. We therefore recommend that the chamber with adequate preparation call a conference of wide representation, including farm co-operative leaders, to study and define measures of sound and effective aid to agriculture.

TRADE NOTES

Effective at once, Link-Belt Company's Baltimore, Md., office will be located at 913 Lexington Building. The telephone number remains the same—Calvert 5741. H. D. Alexander is in charge of this office.

Elevator owners throughout the country are gradually becoming convinced of the risk in stored grain. Heating in bins can occur through many causes other than high moisture content. During the month of April the Zeleny Thermometer Company of 542 S. Dearborn Street, Chicago, installed the Zeleny System in 17 bins for the Enid Terminal Elevator Company at Enid, Okla.

The Macdonald Engineering Company of Chicago, announces that M. E. Crosby, with a wide experience in cement plant and grain elevator work, is now associated with the company as chief engineer. The Macdonald Engineering Company has changed its Chicago address, and now occupies the entire forty-seventh floor of the new One La Salle Street Building, on the corner of Madison and La Salle.

The Douglas Chemical & Supply Company of Kansas City has had a more than usually busy spring, filling orders for "Tetraflume," that non-inflammable ticket to Kingdom Come for every weevil, moth or rodent with which it comes in contact. Mr. Douglas was at Decatur meeting his friends at the Illinois convention. Others have found it extremely profitable to get in touch with the Douglas company when troubled with weevil or moth, and no doubt you would also.

A surprising number of elevators and feed mills have recently been reported as changing their power from gas and oil engines to electric motors. Fairbanks, Morse & Co., of Chicago have been particularly busy with orders for such equipment as their Fairbanks-Morse Type QLS (line start) Motors are particularly adapted to elevator service, for the bearings are permanently sealed against dust and dirt, and one greasing a year is all the attention they require. This not only saves time and labor, but frees the mind of all anxiety as to motor lubrication.

CELEBRATE CENTENNIAL OF MODERN WEIGHING

To commemorate the invention of the modern platform scale by Thaddeus Fairbanks in 1830 business and industrial leaders of the nation, as well as many foreign countries, will gather in the historical city of St. Johnsbury, Vt., on July 4 to pay tribute to the memory of Thaddeus Fairbanks, "father of modern weighing," who gave to the world its first accurate standard of weights 100 years ago.

Announcement of a three day celebration of the centennial of the invention of the modern weighing machine beginning July 4, was made recently in Chicago by W. S. Hovey, president of Fairbanks, Morse & Co., which is the outgrowth of the small scale manufacturing business started 100 years ago at St. Johnsbury by Thaddeus Fairbanks and his brothers Erastus and Joseph P. Fairbanks on an investment of \$4,000.

Former President and Mrs. Calvin Coolidge will be guests of honor at the celebration which has the sponsorship of the Vermont Historical Society, the New England Advisory Council and the Chamber of Commerce. Mr. Coolidge has a keen personal interest in the affair for the reason that he was at one time a student at the St. Johnsbury Academy which was sponsored and supported by Thaddeus Fairbanks.

The principal feature of the program will be an historical pageant depicting the progress during the last century in the evolution of the modern weighing machine and its profound influence upon human welfare and world commerce. There will also be a notable exhibition of original patent models of scales invented by Fairbanks, which have been borrowed from the patent office.

HAY, STRAW AND FEED

IN LOUISIANA anything will grow luxuriously but when it comes to harvesting it the rain gods have a word to say. With an annual rainfall of over 60 inches there are difficulties presented in curing crops, especially Alfalfa and other hay or forage crops.

The finest Alfalfa can be grown in Louisiana and five crops are easily cut, but curing it is altogether another matter. In fact it is so impossible to cure the crop that it does not pay to grow it. The result of this handicap in regard to rainfall is that most of the feeds are shipped into the state.

The Warriners, a prominent and wealthy family of New Orleans, decided that there must be a way to get around this handicap of excessive rainfall. The family includes the father and three sons with an amount of energy that is not always found in the South, who went out 60 miles west of New

New Dehydrating Plant for Alfalfa



does Colorado. Harvesting goes on in both rain and sunshine—everything is done by tractors. The cut hay is brought into the dehydrating plant directly from cutting—no shocking or stacking—it is dehydrated and the most beautiful color imaginable is retained in the dried and cut hay. There is an appetizing odor about hays so dehydrated that is

secured in hays harvested in the ordinary way. It would seem from reports that have come in from feeders all over the southern part of the states of Mississippi, Louisiana, and Texas that there are certain nutritious elements in these dehydrated feeds that are not found in other kinds of feeds.

The feed mill equipment was furnished by the Anglo American Mill Company and consists of Miracle Ace Hammer Mills, Miracle Batch Mixers and a 20,000-pound No. 4 Miracle Molasses Process, and other subsidiary equipment—in fact, this entire mill was designed by Anglo American Mill engineers.

The great success of this firm, known as Warriner Farms, has brought attention to the results to be obtained by dehydrating. One of the recent direct results has been the formation of the Mason Mills, Inc., at Pauls Valley, Okla., where a similar



DEHYDRATING PLANT AT WARRINER MILL



WARRINER FEED PLANT NEAR THIBODAUX

Orleans, in that fertile part of the state known as the Sugar Bowl, and purchased three plantations of approximately 6,000 acres, one of them being the White plantation, formerly owned and operated by Justice White of the United States Supreme Court. On the White plantation six miles from the town of Thibodaux, they have built an enormous dehydrating plant and a modern feed mill.

On this enormous acreage they are raising Alfalfa and soy beans. They have entirely eradicated the bugbear of harvesting. They cut their five crops of Alfalfa just as though they had no more rain than

difficult to describe, but it is so appetizing that everyone mentions it as a dish that is almost fit for the table. From the dehydrating plant the hay goes to a hammer mill and is blown up into a storage house and from this is taken into the mill and processed into various kinds of sweet feeds.

This plant has been operating only about one year but in that time the big W brands of feeds have established themselves in every market where they have been introduced. Cutting the Alfalfa or soy beans before they mature enables them to retain a larger proportion of protein than is ever

dehydrating plant and mill is now being built. The Anglo American Mill Company engineers designed this plant and it will be equipped with an entire line of the Miracle Sweet Feed System machines. This plant will be ready for its first cutting within a very short time.

Dehydrating has opened an entirely new field of feed manufacturing, and offers not only feeds of unusual nutritious qualities but finished feeds at a lower price production than has heretofore been possible all of which is good news to feeders in general.

FEED COSTS AND RETAIL EGG PRICES

Profits in poultry bear a close relation between feed costs and poultry and egg prices, says a contributor to the bulletin of the Ohio Agricultural Experiment Station at Wooster. Of the total cost of producing poultry and eggs on Ohio farms, from 50 to 60 per cent is feed cost. The price of feed varies from month to month and year to year, while the other important items of cost, labor, and overhead remain fairly constant. Profit in the poultry industry depends on the margin between cost of production and the amount received for the products. The price received for eggs and poultry may be low, yet if feed prices are correspondingly low the margin of profit may be as great or even greater than in a period of high feed and poultry prices. In years when feeds are scarce and poultry products are low, the amount of feed that a given amount of poultry products will buy will be small. In years when the opposite is true the ratio of feed prices to the price of poultry and eggs will be high.

The ratio of poultry feed to the price of eggs and poultry would indicate that 1929 was the most profitable year for the Ohio poultry producer since

1922. Feed prices for 1929 were average or slightly below average while the price of both eggs and poultry were above average. The price for eggs and poultry during 1929 was accompanied by an increase in the number of chicks raised, which was reflected somewhat in a lower price for live poultry during the last few months of the year.

The feed-egg cost ratio is likely to be more favorable for feeders in 1930 than in 1929, due to lower grain prices.

ALFALFA MEAL PRODUCTION DIMINISHES

Production of alfalfa meal in the United States during March, 1930, totaled 22,871 short tons, according to reports received from meal manufacturers by the United States Department of Agriculture. This production was only about half that for the previous month and less than was reported for March during either of the past two years. This season's production to date is 24,725 tons less than for the corresponding period last year but 37,298 tons above the production from July through March two years ago.

GROUND OATS FOR GENERAL FEEDING

In spite of the decrease in the number of horses, formerly the chief and practically only consumers of oats, that grain is steadily increasing in popularity. N. C. Murray of Clement, Curtis & Co., finds that in comparing oats and corn acreages for the first and the third decade of this century, oats acreage increased 32 per cent, as against 7 per cent for corn.

Due to the fact that in so many communities feed grinders are available, oats can now be used to feed cattle and young stock, and even poultry, when it was out of the question before grinding became common practice. Stocks of oats remaining on farms on May 1 were estimated at 176,000,000 bushels. Only in the far West and in Nebraska is the present supply greater than the prospective demand until harvest, compared with last year.

Fine ground oats or oat groats are a part of so many standardized feed formulas that there is every prospect that the demand will steadily increase, irrespective of the usefulness of the horse as compared with automobiles, trucks and motorized farm equipment.

STOCK FEEDS SEIZED IN EAST

Twenty-six seizures of stock feeds were made under the Federal Food and Drugs Act in the eastern inspection district of the Food, Drug and Insecticide Administration of the United States Department of Agriculture during the year ending December 31, 1929, according to W. R. M. Wharton, district chief. The Eastern district includes all the Atlantic Coast States and Vermont, Pennsylvania and West Virginia.

The seizures covered 10 consignments of cottonseed meal, 2,145 sacks in all, 14 consignments of mixed feeds and miscellaneous feed products totaling 2,833 sacks, and 2 shipments or 35 sacks of beef scrap. In addition to these seizures 27 citations to hearings were issued to manufacturers and shippers on charges of violating the act, 2 cases have been referred to the solicitor of the Department of Agriculture for prosecution, and others may follow.

The principal violations encountered, according to Mr. Wharton, were deficiencies in protein and fat, excessive crude fiber, and labels and tags bearing improper declarations of ingredients of the feeds.

A MILLION FOR MACARONI

More than \$1,000,000 are to be spent by members of the National Macaroni Manufacturers Association in increasing the sales of macaroni products. The first million of the fund already has been oversubscribed. This may materially increase wheat consumption in this country.

A recent investigation, conducted preliminary to the launching of the national co-operation advertising campaign, shows that macaroni products are served in the average American home on the average of only once a month; and that housewives, in general, know only two ways of preparing macaroni for the table.

The advertising campaign will extend over a period of four years and has been planned by the association under the direction of G. O. Browne, in co-operation with an Indianapolis advertising company. F. J. Tharinger, Milwaukee, Wis., is president of the National Macaroni Manufacturers Association and M. J. Donna, Braidwood, Ill., is secretary-treasurer.

HAY MARKET LIGHT

Offerings of hay during the week ending May 9 were seasonably light at all markets, due to limited old crop supplies and the first cutting of Alfalfa being delayed in many sections by unfavorable weather for curing and baling. Demand was also limited and quotations showed little change at most markets, according to the weekly hay market review of the United States Bureau of Agricultural Economics.

Timothy markets held about steady with moderate receipts and a fair demand. Offerings were somewhat heavier and largely of the medium and lower grades at Boston but quotations on all grades were unchanged. Arrivals were liberal the forepart of the week at New York and prices declined slightly but demand improved at Brooklyn where prices advanced \$1 to \$2 per ton. The accumulation was absorbed and quotations the last of the week in New York proper were unchanged from the previous week. Timothy of the better grades was in demand at Pittsburgh at steady to stronger prices. Increased receipts forced Timothy prices down \$1 per ton at Cincinnati the first of the week but lighter offerings toward the close permitted a recovery to about the previous week's levels. Clover remained \$1.50 lower. Receipts were considerably heavier at Atlanta but consumption also increased as dry weather shortened pastures and quotations were only slightly lower. Offerings were moderate at Birmingham and prices held about unchanged.

Receipts were too light at Minneapolis to make a market. However, an occasional car was received on previous to arrive purchases. Demand was slow but sufficient to absorb the moderate offerings at steady prices. Receipts at Chicago the first half of

the week were heavier, being equal to the total offerings for the previous week, but were retarded somewhat toward the close by inclement weather and pressure of spring farm work. The quality of arrivals was fair to good. Moderate offerings of top grade from northern Michigan sold readily at that market at premiums over State hay. Receipts at Kansas City, although not heavy, were slightly larger than for the previous week but the quality was generally poor and price concessions were necessary to move the lower grades. The upper grades however held steady due to a good demand from shippers and retailers.

Alfalfa offerings continued light with old crop supplies about depleted in all principal producing sections and unfavorable weather for curing and baling holding back offerings in Oklahoma and California. The demand, however, was only moderate and quotations were unchanged to slightly higher at most markets. Arrivals at Kansas City were less than half those for the previous week, but apparently equal to trade requirements and quotations were unchanged. No new crop hay was offered in that market the past week due to unfavorable weather for making hay in Oklahoma and high cost of transportation from New Mexico and Arizona. Top grade Alfalfa moved readily at Omaha at somewhat higher prices but brown and low grades were slow sale.

California Alfalfa markets advanced 50 cents per ton due to damp and rainy weather which hindered loading and hauling somewhat. An improved demand from dairymen, particularly for the better grades, was a strengthening factor at Los Angeles. Feeders and buyers for the grinding trade, however, showed little interest and mixed and low grade offerings were slow sale. San Francisco reported a quiet market with light receipts, particularly of the old crop, which commanded considerable premium over new crop offerings. Fairly good sales to eastern markets were reported at around \$32 per ton, delivered New York or Boston.

FEED RATES PROTESTED

The charge has been filed with the Interstate Commerce Commission by the Ralston-Purina Company, Inc., St. Louis, Mo., that the rates of the Atlanta, Birmingham & Coast Railway on less than carload lots of oyster shells from Nashville, Tenn., to points in Alabama, Georgia, Florida, Kentucky, North and South Carolina, Tennessee and Virginia are unreasonable.

The complaint of the Pillsbury Flour Mills Company, Minneapolis, against the Akron, Canton & Youngstown Railway has been scheduled on the current docket of the Interstate Commerce Commission.

The company asks for a cease-and-desist order, and reparation on rates applied to shipments of feed by-products, flour, grain, and miscellaneous products originating at points in Minnesota, Iowa, Kansas, Oklahoma, Nebraska, Colorado, Wyoming and Texas.

Establishment of "reasonable" rates is requested, and also an interpretation, by the commission, of any rates allowed to stand.

FEED MARKET REVIEW

Feedstuffs markets presented a mixed price picture during April, according to the feed market review of the United States Bureau of Agricultural Economics. Lateness of pastures, small supplies of feedstuffs in most positions, and advancing dairy products prices were the principal causes for an unusual display of market strength around the middle of March. Bran prices advanced \$6 to \$7 per ton from the middle of March to the close of April at the principal distributing markets, while linseed meal and cottonseed meal advanced \$4 to \$7 per ton. Hominy feed showed about the same firmness as other feeds to the middle of April and then turned downward, influenced by the weakness in feed grains. Gluten feed and meal held steady during April but alfalfa meal prices declined slightly and were largely of a nominal character. In contrast to April's strong market, the situation early in

May was weak and unsettled with a general slackening in demand. This, together with improving pastures and declining feed grain prices, more than offset the influence of the small available supplies of feedstuffs.

The sharp price advance in wheat feeds during practically all of April was confined mostly to bran for delivery within a very short time. Dairymen took a fairly large tonnage of bran as feeding became more profitable with the improved dairy product prices, but it was also true that on account of late pasturage low stocks needed replenishing. Shorts and middlings did not advance as much as bran, due to a slow demand from spring pig feeders and the competition with cheap corn, oats, and corn by-product feeds. Shorts were slow sale even at the same prices as bran, which moved readily in certain central western markets at the close of April. Prices of wheatfeeds declined sharply early this month, partly as a reaction from April's higher prices and partly because of the better pastures and lower feed grain prices.

The outturn of offal has not been so important a factor as demand so far this season. Production of wheat millfeeds since the beginning of the season has totaled practically the same as last year. However, March and April production was heavier than in the same months last year.

Supplies of linseed meal have been unusually small but prices were about the same per ton in the past month as in April of the two previous years, but prices have declined so far in May. Production during the quarter ending March 31 was the smallest for that quarter since 1922 and only totaled about 150,000 tons. Of this, about 68,000 tons were exported which left only around 82,000 to be shipped to consumers.

Cottonseed meal is costing more than a month or a year ago. The small supplies of linseed meal, shortage of feed supplies in the Southwest and low prices of cottonseed meal induced consumers to use around 150,000 tons more than they did last year. As a result, stocks of cottonseed and cottonseed meal are the lightest in recent years. It is little wonder that cottonseed meal prices have advanced in recent weeks while other feeds have declined.

Gluten feed and meal production appears to have been fairly well in line with fair but scattered demand, as prices have not changed in the past month. However, they are nearly \$5 per ton less than a year ago. The outturn of this feed as indicated by wet-process grindings is about 11 per cent under last year, but April production was heavier than in February or March and more than in April last year.

Hominy feed advanced early in April but declined towards the close of the month with corn prices, heavier production and a slackening in demand. During summer months this feed follows corn prices quite closely.

The small supplies of alfalfa meal have been sold at steadily declining prices, despite the fairly strong market for alfalfa hay and the lightest March production in recent years.

N. Y. FEED PRICES RISE AND DIP

By C. K. TRAFTON

Developments in the New York feed market during the last 30-day period were largely of a seasonal nature. In fact, climatic changes and especially the abrupt reversal from very low to very high temperatures was a more potent influence than usual. This applies particularly to the wheat feeds which continued to advance early in the period and reached "peak" levels toward the end of April and subsequently declined roughly \$1 to \$2 per ton. The early strength was due to the belated opening of lake navigation as a result of the very cold weather which delayed arrivals from Buffalo and the Northwest; some Duluth shipments, as a matter of fact, being tied up until May 2.

The holding-up of these supplies offset for the time being the continued liberal imports from South America, the smaller receipts from Argentina being made up by large arrivals from Brazil. At any rate, demand for wheat feeds was better than usual late

in April, but the resultant higher prices stimulated increased grinding and larger offerings from all quarters, including Canadian, while the much warmer weather not only served to release the water traffic, but also resulted in much more cattle being put out on pastures, thus materially restricting consumption of feeds. Spring bran, for immediate rail shipment, after selling up to \$37, fell to \$35, while quick lake and rail shipment is quoted at \$34. Standard middlings averaged about a half-dollar less throughout. Red Dog sold at \$39, and is now \$38.50.

South American bran, origin not stated, is offered for May-June-July-August arrival in New York at \$27.50 duty-paid f.o.b. cars, with middlings at a half-dollar less. Corn goods had a seasonal decline in keeping with the easier grain markets. There was a moderate trade in white hominy, all rail, at \$36.50 and later at \$36, with lake and rail now quoted at \$35. Demand for yellow hominy is slow as usual in this district, but at the same time there is very little offered and the nominal rail basis is \$35.50, with no lake and rail offers noted.

Linseed oil meal was very quiet and without important change, 32 per cent being quoted at \$51, and 34 per cent at \$53. Domestic beet pulp, although not freely offered, was available at a half-dollar concession, i.e., \$44.85 N. Y. rate points, and hence the imported variety failed to advance from the previous basis of \$36, duty-paid f.o.b. cars for choice light gray.

LOSSES CANCEL HAY PRICE GAIN

Seasonal developments featured the action of the New York hay market during the period under review, the advent of much warmer weather finally bringing about decreased consumption and a material enlargement of river arrivals, the combination causing a partial reaction after prices had advanced quite sharply.

At the outset arrivals were very light and with the railroads unloading very slowly, top prices were readily obtainable for all hay really coming up to grade. This was especially true of small bales which sold on even terms with the large for a time. The shortage was especially marked in Brooklyn and many buyers there came over to the Manhattan yards where prices averaged about \$1 lower. After mid-April, river arrivals began to increase, but temporarily the market retained its firm tone and peak prices of \$31 to \$32 were established for really choice No. 1, while no sound hay was to be had below \$21. With river hay piling up and stocks accumulating at rail yards toward the end of the month, sellers became more eager, especially in Manhattan where prices reacted \$1 to \$3, with Brooklyn still relatively short and paying a premium.

A \$1 discount was re-established on small bales which made up a large proportion of the arrivals and especially of the fairly large quantity coming in from Canada when prices were at the top. The decline shut off further offers from that direction, but experience and conservative distributors look for still lower prices as they expect continued liberal receipts of domestic hay, especially No. 2 or lower grades.

A TRIBUTE TO F. B. WISE

With the death of F. B. Wise in New Orleans, La., a month ago, the rice industry of the United States and particularly the Rice Millers Association lost an able servant and a man who was beloved by all who knew him. Mr. Wise was stricken with appendicitis and was taken to Touro Infirmary a week before his death but the operation to save him was performed after the appendix had ruptured.

Furman Bryant Wise was born in Hyman, S. C., on February 6, 1888, and obtained his early education in his native state. After his preparatory work he entered Clemson College and graduated there in 1908 with the degree of Bachelor of Science.

After his graduation from Clemson College, Mr. Wise taught school for two years and it was during this time that he first went to the State of Louisiana where he was later to go and spend the last

years of his life. After teaching for two years, Mr. Wise entered the University of Wisconsin and graduated in 1911 with the degree of Master of Science.

After his graduation from the University of Wisconsin he entered the employ of the United States Department of Agriculture and was placed in charge of the rice standardization work which was then in the Bureau of Plant Industry. He remained in this work until 1919 and it was during the time that he was with the United States Department of Agriculture that his work attracted the attention of the rice industry as a whole and particularly the rice millers.

Mr. Wise was the author of several published articles on rice and was the author or co-author of some bulletins issued by the Department of Agriculture. He also formulated the first grades for milled rice issued by the Department of Agriculture, which were the first definite standards to be used in the United States for the grading of milled rice.

In 1919 Mr. Wise left the employ of the Department of Agriculture and became secretary-treasurer of the Rice Millers Association and in 1920 he established the rice grading service which has become the largest of its kind in the South. The success of the service in the beginning was due very largely to the faith which buyers and sellers had in the integrity of the man under whose direction the service had been established and the grading was done.

In obtaining and compiling statistics Mr. Wise had rare ability and his geniality, diplomacy, and keen insight into the problems of the rice milling industry made him a man of inestimable value to his employers. Men as versatile as Mr. Wise are hard to find and the rice millers of the South will feel their loss keenly.

Mr. Wise had a host of personal friends in and out of the rice industry and these friends will miss his ready wit, his wholesome character, and his loyalty. He is survived by his wife, his mother, who lives on the old plantation at Hyman, S. C., three sisters, and one brother.

SEVENTH VITAMIN CLAIMED FOR COTTONSEED MEAL

Cottonseed meal, commonly used as a cattle feed, has been found to be a substance rich in Vitamin G, the anti-pellagra vitamin, and by far the cheapest source of this vitamin, Dr. W. W. Skinner, of the Bureau of Chemistry and Soils, United States Department of Agriculture, announced May 10.

Results of nutrition studies on cottonseed meal for the last year were reported to the American Oil Chemists' Society at New Orleans by Henry Stevens, who has been in immediate charge of the work. The studies are being conducted jointly by the Department of Agriculture and the National Cottonseed Products Association.

"In addition to being rich in Vitamin G, Stevens found cottonseed meal to be an important carrier of Vitamin B, the anti-beriberi vitamin," Dr. Skinner said. "Yeast is considered by chemists to be the richest known natural source of these two vitamins, and the work of Stevens has demonstrated that commercial cottonseed meal, even in the unrefined state, is the only substance that even approximates yeast as a source of both of these vitamins. Yeast is now used as a specific in the treatment of pellagra, but the cost of yeast is high to sufferers from the disease."

Stevens used rats in his first tests of the nutritive value of cottonseed meal. The results indicated that this meal is an unusually rich source for Vitamins B and G, and this unexpected discovery led him to further studies in an effort to determine how the vitamin content of cottonseed meal compares with other materials. This work led to the conclusion that cottonseed meal ranks next to yeast in content of Vitamins B and G.

Pellagra is a disease resulting from improper diet, and is fairly common in many parts of the South. In 1926, Dr. Joseph Goldberger of the Public Health Service, demonstrated that this disease is due to the lack of specific substance in the diet.

This substance, which is of unknown chemical composition, is known as Vitamin G, and is found in lean meat, fish, eggs, and milk.

No experiments have been conducted with farm animals to determine their need for Vitamin G, but investigations by the department and state experiment stations have shown that cottonseed meal in moderate quantities is an excellent feed for cattle.

FEED RATE COMPLAINTS

The Globe Grain & Milling Company, Los Angeles, Calif., has filed a new rate complaint with the Interstate Commerce Commission, involving feed as well as grain shipments.

The complaint is in connection with shipments of feed, whole grain, and miscellaneous grain products under transit in Los Angeles for final delivery at California points. The cars were prepaid on a basis of 50,000-pound minimums. The Southern Pacific Railroad demanded the "surrender of transit" at the minimum of 60,000 pounds, and upon the grain firm's refusal, assessed full local rates. Reparation is asked.

The Noble & Reid Grain Company, Hamburg, Iowa, has filed complaint with the Interstate Commerce Commission against the C. B. & Q. Railroad, asking for just and reasonable rates on wheat and corn between points in Iowa, Nebraska, and Missouri.

GOVERNMENT REVIEWS FEED GRAIN PRODUCTION

The total 1929 production of the three feed grains, barley, corn and oats, in the United States amounted to only 100,610,000 short tons compared with 110,540,000 short tons in 1928, and 102,670,000 short tons in 1927. The 1929 European production, however, was 70,190,000 short tons against only 58,561,000 short tons in 1928, and 57,216,000 short tons in 1927, according to the Government's May report on foreign crops and markets.

BARLEY

The 1930 area sown to barley in 10 countries stands at 27,589,000 acres, an increase of 1 per cent over the area sown by the same countries last year. The winter barley crop in Hungary and the Balkan countries is reported to be developing well recently on account of the mild, rainy weather.

It was officially reported that the area sown to barley in the U. S. S. R. up to about the middle of April was 95 per cent of the intended area in the Crimea, 60 per cent in Northern Caucasia, 53 per cent in the Ukraine, 19 per cent in the lower Volga, and 18 per cent in the central black-soil region.

Several revisions have recently been made in 1929 production figures so that the total for the 42 countries reported is 0.1 per cent above that for 1928. The European total is 9.7 per cent above that of the preceding year, due to an increase of nearly 5,400,000 bushels in the previous figures for Czechoslovakia, though there was a decline of about 150,000 bushels in the earlier estimate for the Netherlands. The earlier figure for Morocco was increased by nearly 9,000,000 bushels to 47,316,000 bushels, though some trade reports consider this figure a little high. The third official estimate of the 1929-30 barley crop in Argentina is 16,121,000 bushels, an increase of nearly 500,000 bushels over the second estimate, but about 4 per cent below that of the preceding year.

Exports of barley from the United States, Canada, Argentina, and the Danubian countries from July 1 to the latest dates available total 90,524,000 bushels, a decrease of 15.2 per cent from the shipments during the same periods of the preceding year. United States barley exports during the week ended April 26 were the largest weekly shipments since the beginning of March. There was little change in prices. No. 2 barley at Minneapolis remained at 55 cents per bushel, 9 cents below the price for the corresponding week last year.

Stocks of barley in store in the western grain inspection division of Canada on April 25 amounted

to 21,455,000 bushels compared with only 13,644,000 bushels on the same date last year, and 7,569,000 bushels in 1928. Receipts of barley at Fort William, Port Arthur, and Vancouver from August 1 to April 25, 1929-30, amounted to 15,196,000 bushels, while shipments during the same period totaled 4,597,000 bushels.

The demand for barley in the United Kingdom at the beginning of May was reported slow after active buying of Danubian varieties. The weekly average consumption during the first quarter of 1930 was only about 60 per cent of the weekly average during the preceding quarter, but 12 per cent above the average for the corresponding weeks of last year.

It was estimated, according to Vice-consul Frederick H. Henrotin, that about half of the 1929 barley crop in Morocco was still unsold at the beginning of March, 1930, and that a large portion of it was stocked at the ports in the hands of merchants. Large shipments were made during the year to the Souss territory, where there was a crop failure.

OATS

The 1930 area sown to oats in seven countries reported stands as previously reported at 46,042,000 acres, an increase of 3 per cent over the area sown by the same countries last year. Owing to the adverse conditions of the winter, the area under oats in the Irish Free State is said to be smaller than usual.

Recent revisions in the 1929 production estimates have increased the total for the 38 countries reported to almost 95 per cent of the 1928 harvest. The European total is now 8.7 per cent above that of 1928, due to an increase of nearly 8,800,000 bushels over the previous estimate, although there was a decrease of 3,000,000 bushels in the earlier figure for the Netherlands. The earlier estimate of Morocco has been increased by about 250,000 bushels, while the third official estimate of the 1929-30 oats crop in Argentina is 1,300,000 bushels above the second estimate, and nearly 5 per cent above that of 1928-29.

Exports of oats from the United States, Canada, Argentina and the Danubian countries from July 1 to the latest dates available amount to 26,364,000 bushels, a decrease of 46.1 per cent from the shipments during the same periods of the preceding year. United States oats exports continued very small during the week ended April 26, and prices declined slightly. No. 3 White oats at Chicago dropped one cent to 42 cents per bushel, which was five cents below the price for the corresponding time last year.

Stocks of oats in store in the Western Grain Inspection Division of Canada on April 25 stood at 11,558,000 bushels against 19,322,000 bushels on the same date last year, and 11,742,000 bushels in 1928. Receipts of oats at Fort William, Port Arthur, Vancouver, and Prince Rupert from August 1 to April 25, 1929-30, totaled 3,691,000 bushels, while shipments during the same period amounted to 7,160,000 bushels.

It has been estimated that there is a surplus of 40,000,000 bushels of oats over ordinary requirements in Germany this year, and 56,000,000 bushels more than two seasons ago, when during the April-June quarter Germany was a net exporter of about 1,000,000 bushels of oats. There was presumably a considerable carryover of oats from last season. Oats were reported dull in Denmark at the middle of April, and there seems to be considerable doubt what the price of Germany oats will be during the coming months.

CORN

There was a marked reaction to cooler weather in the grain sections of Argentina during the week ended April 28, according to the United States Weather Bureau. The mean temperature in the corn zone was 61 degrees, or exactly normal, while the precipitation continued heavy, 1.6 inches being reported. A representative of Broomhall's *Corn Trade News* reported about the middle of April that the Argentine corn crop had suffered most in the low yielding zones, and that it is probable that the best yielding areas will compensate for the losses

in the poor areas. He still believes that there will be an exportable surplus of nearly 296,000,000 bushels. There has been an increase of about 1,000,000 bushels in the earlier estimate of the 1929 corn crop in Morocco, which raises the total for the 22 countries reported to 3,485,611,000 bushels, or 1.7 per cent above the 1928 harvest.

Exports of corn from the United States, the Danubian countries, Argentina, and the Union of South Africa from November 1 to the latest dates available amount to 99,677,000 bushels, a decrease of 12.6 per cent from the shipments during the same periods of the preceding year. United States corn exports during the week ended April 26 were the largest weekly shipment since early in March, while Argentine shipments amounted to about 2,750,000 bushels, the same as a week earlier.

BEANS

BULLETIN EXPLAINS CONTROL FOR PEA AND BEAN WEEVILS

Bean dealers should stand ready to advise their customers on the weevil problem in the light of the newest weevil control methods. Every year when planting time comes many farmers and gardeners are surprised to find that their seed beans or peas are ruined by weevils even though the seed has been kept in tightly closed containers. At one time there was a popular belief that weevils developed spontaneously from the germ of the seed, but this idea has gradually given way as the facts in the life history of the weevil have become more generally known. These facts are fully explained in a revised publication of the United States Department of Agriculture, Bulletin No. 1275-F, "Weevils in Beans and Peas."

Beans and peas may become infested with weevils while growing in the field. Female weevils lay eggs in or on the pods, and the young grubs work their way into the seed by burrowing out a hole no larger than a pin prick, too small to be seen by the unaided eye. After the seed is harvested and put in storage the weevils continue breeding at a rapid rate. Infested seeds in bulk usually heat, thus producing the temperature and moisture conditions most favorable for the rapid development and vigorous breeding of weevils.

Infestations in beans and peas can be quickly and effectively stamped out, says the bulletin, by fumigation with carbon disulphide, carbon tetrachloride, or hydrocyanic-acid gas, and by means of heat or cold storage. Weevils can be prevented from continuing to produce new generations in storage by mixing dust or air-slaked lime with the seeds. This remedy tends to dry out the seeds and kill the grubs within them. It also prevents those weevils that succeed in developing from leaving the seeds. Copies of the bulletin, 1275-F, may be obtained, as long as there is a supply available for free distribution, from the Office of Information, Department of Agriculture, Washington, D. C.

BEAN SEED INOCULATION

Bulletin No. 372, published by the University of Wisconsin at Madison, cites records showing that inoculating of pea seed, similar to that applied to beans, resulted in increasing production per acre from 117 to 843 pounds.

Beans and peas, inoculated with bacteria at the time of planting, increase the harvest substantially. The tiny, laboratory-born bacteria cling to the seed coat at planting time, and later established themselves in the nodules formed in the sprouting period and draw down nitrogen from the air.

U. S. BEANS FOR U. S. S. R.

George W. Hendry, of the University of California at Berkeley, lists nine bean varieties as among those which are being tried out, under government supervision, on the communists' farms of the Union of Socialist Soviet Republic. They are: Lady Washington, Blue Pod, Blackeye, Cranberry, Bayo, Garbanzo, Red Mex, Horse, and Henderson Bush Lima.

All of these are grown on the Pacific Coast, and several of them are expected to be produced successfully by Russian farmers.

The American elevators now being erected in the U. S. S. R., will serve as concentration points for Russian beans and peas, as well as grains.

CITES BEAN STORAGE LAWS

H. A. Haring, in his book on Warehousing, calls attention to the various degrees of liability incurred by bean dealers in various sections. He says:

"The law, as is logical, protects the warehouseman against injustices. He is, for example, not held liable for the natural deterioration of perishable goods, nor for loss of weight due to evaporation of contained moisture. In some instances, he is not held liable for the ravages of vermin.

"In California and the Southwest, he is liable for the bean weevil which matures, in those sections, in stored beans after five or six months, whereas in Michigan and Wisconsin he is responsible for damage to beans caused by vermin or insects (the bean weevil in northern sections not maturing under storage conditions).

"He is not liable for heating (fermenting of corn) in elevator storage, whereas for heating of wheat and other grains his responsibility is almost absolute."

NEW FEED BRANDS

"OLD VD DUTCH" for poultry and stock feeds, etc. Henry W. Von Damm, doing business as F. H. Von Damm, Brooklyn, N. Y. Filed December 28, 1929. Serial No. 294,195. Published April 8, 1930. Claims use since January 1, 1929.

"BLUE RIDGE" for horse, cattle, chicken, and hog feeds. Shenandoah Milling Company, Inc.,

HEAVY DUTY LOGGING RATION

BLUE RIDGE

Old Dutch

Shenandoah, Va. Filed March 11, 1930. Serial No. 297,154. Published April 22, 1930. Claims use since 1917.

Not Subject to Opposition

"HEAVY DUTY LOGGING RATION" for stock feed. Josey-Miller Company, Beaumont, Texas. Filed February 11, 1930. Serial No. 295,901. Published April 8, 1930. Claims use since July 1, 1924.

Trademarks Registered

269,585. Stock and poultry feed. General Mills, Inc., Minneapolis, Minn. Filed July 15, 1929. Serial No. 287,133. Published January 28, 1930. Registered April 15, 1930.

269,707. Poultry and stock feeds. Wilkins-Rogers Milling Company, Inc., Washington, D. C. Filed December 5, 1929. Serial No. 293,303. Published February 4, 1930. Registered April 15, 1930.

Trademark Registrations Renewed

78,162. Grass seeds, garden seeds, and seed grains. Registered May 31, 1910. Cargill Elevator Company. Renewed May 31, 1930, to Minneapolis Seed Company, Minneapolis, Minn., a corporation of Minnesota, assignee. Registered April 15, 1930.

78,376. Seed grains, grass seeds, and garden seeds. Registered June 7, 1910. Cargill Elevator Company. Renewed June 7, 1930, to Minneapolis Seed Company, Minneapolis, Minn., a corporation of Minnesota, assignee. Registered April 15, 1930.

78,377. Seed grains, grass seeds, and garden seeds. Registered June 7, 1910. Cargill Elevator Company. Renewed June 7, 1930, to Minneapolis Seed Company, Minneapolis, Minn., a corporation of Minnesota, assignee. Registered April 15, 1930.

Illinois Grain Dealers Association Meets

M. J. Hogan was chosen to succeed L. A. Tripp as president of the Illinois Grain Dealers Association in Decatur, May 6 and 7. All other officers were re-elected and are: First vice-president, F. W. Stout; second vice-president, H. R. Meets; secretary, W. E. Culbertson; treasurer, M. J. Porterfield. The new directors chosen include J. A. Gilles, L. A. Tripp, R. A. McClellan, and F. S. Ware.

Members of the Illinois Grain Dealers Association who met at Decatur, May 6 and 7, for their thirty-seventh annual convention are firmly convinced that the Federal Farm Board isn't going any place and that it won't take a long time to get there. Charles Quinn, secretary of the Grain and Feed Dealers National Association, speaking on the afternoon of the second day, voiced the sentiments of attending grain men when he declared the farm board had two alternatives—and neither were anything to cheer about.

They can either hoard all the grain and build up a record surplus, Mr. Quinn said, or they can cut down the farmers' wheat acreage. And the first procedure is doomed to failure while the second is impossible.

While it is customary to have the mayor on the program for a "few opening remarks" it is not quite so customary to actually have him appear, for he usually delegates this important duty to his thirty-third assistant. But Mayor Smith of Decatur,



L. A. TRIPP

being a conscientious gentleman, gave the address of welcome according to schedule, inviting the grain men to make themselves at home, which they did.

The official program was opened by President L. A. Tripp, whose address follows:

PRESIDENT'S ADDRESS

In compliance with the provisions of our by-laws we are here for our thirty-seventh annual convention. Another year has been added to the history of our association. It is with a feeling somewhat akin to regret that I present to you this annual message which will be my valedictory attempt along these lines. For two years it has been your pleasure for the speaker to serve as your presiding officer and I appreciate the confidence bestowed.

Year 1929

The past year like many others has been crowded with many problems confronting the grain trade and the major part are still unsolved. The country is now emerging from trying conditions. It is only just beginning to recover from the depression in certain lines of business long continued and altogether unparalleled. Progress, therefore, will naturally be slow, but let us not be impatient. Rather let us exercise a just patience and one which in time will surely bring its own high reward.

Farm Bill and Board

We now have both a farm bill and a farm board and the discussion of the advantages and disadvantages have been carried on from time to time by practically all our newspapers and various trade papers. At times it almost seems we are applying the measure with printers ink rather than actual operation. I have no fear for the future of the grain trade. While I discern in its present condition the necessity that always exists for the faithful devotion of the trade, the history of its past assures me that this will be, as it always has been through every attack and emergency, still onward and upward. It has never suffered from any trial or been unequal to any test. No Government controlled or directed business

will ever be operated as economically as private business. I would recommend that our resolutions committee prepare a suitable resolution, expressing our position to any activities of the farm board which encroach on the rights and property of the already established grain trade and our support and aid to those things which go to the help and improvement of the agricultural industry.

Rights of the Grain Trade

The grain business is a legitimate, competitive, and necessary service. It must be rendered by some private agency, co-operative or otherwise, and a reasonable margin of profit must be secured to insure the continuance of same. Therefore, let us take courage, maintain the rights of the grain trade and uphold our standards.

Evils Within

There is a great work to do and much to be accomplished in eliminating unfair and unethical practices between grain dealers in the various lines and I feel that more harm is being done from within rather than those from the outside. I wish again to commend our secretary, Mr. Culbertson for his untiring efforts in promoting local meetings to bring closer relations between dealers and more pleasant business conditions.

Accident of Secretary

It was the misfortune of our secretary to fall upon the ice last January and fracture his right leg which has been some hindrance to his personal visits upon the members. Mr. Culbertson tendered his resignation upon meeting with the accident but after submitting it to the directors it was decided that with the aid of his assistant, Mr. Patzer, as much or more could be accomplished for the association by retaining Mr. Culbertson as secretary rather than appoint some one not familiar with the work. I am pleased to say, as you can see, he has sufficiently recovered to attend our annual convention and in the near future will again meet you in your places of business with his word of cheer and valuable help and assistance.

Grain Trade Discussion

There are many phases of the grain trade I could bring to your attention and discuss them at some length but I deem it unfair to take up your valuable time, as I do not know of any part or angle that has not been touched upon by our grain papers and I assure you we have ample talent to follow on our interesting program who can handle these matters to your entire satisfaction.

Conclusion

I wish again to thank the officers, directors, committees and members for their assistance and co-operation and will close by wishing you joy, happiness and prosperity for 1930. I thank you.

This address was followed by the annual report of the secretary, read by W. E. Culbertson and is as follows:

SECRETARY'S REPORT

What's ahead for the grain trade, is the question foremost in the thoughts of every grain dealer with whom I have talked since the passage of the Agricultural Marketing Act. The farm board, through Mr. McKelvie, the member representing grain, has stated that "it is expected to eliminate the country elevator as a grain merchant," however, I believe the answer rests with the American farmer, and I further believe his answer will be "Business as Usual." It should be borne in mind that the farm law does not represent a genuine farm request but something passed along by the politicians, and while the farm board may desire to do away with the country elevators as grain merchants the farmer may not. The farmer knows it is just as necessary for him to have a place to take his grain and sell it as it is to have the land upon which to grow it. Today our system of grain marketing has no equal anywhere in the world when it comes to stability and efficiency. The Federal Trade Commission says grain is handled and marketed at less expense than any other farm commodity, yet it is this system that the farm board desires to destroy in order that an idea of co-operative marketing may be tried.

Speaking of co-operation, the extremely exaggerated statements made with reference to the possible results of co-operative activities are nothing short of criminal. Within certain very definite limits and with certain kinds of commodities the co-operative idea has some possibilities. We have some successful examples of co-operative enterprises and, on the other hand, millions of dollars have been lost by farmers through co-operative activities. There is no magic in the word "co-operation." A co-operative activity to be successful must enjoy honest and efficient management and must operate with due regard to sound business principles. The independent grain dealer competing with a co-operative elevator has no right to complain if, given an equal opportunity, he is unable to survive in such competition. All he asks is an equal opportunity from a competitive standpoint, a fair field, and no favors, but for the Government to subsidize the co-operative is most unfair. To render the greatest service to the public individual initiative and enterprise should never be supplanted by monopolistic control. There is no reason why citizens generally should be taxed to furnish Government funds to subsidize and experiment in marketing that the farm board admits cannot succeed unless it can persuade the farmer to cut down his production and to permit its agencies to act as his conservator.

Your association, a member of the Chamber of Commerce of the U. S. A., requested that body, by resolution and through our delegates, to go on record as opposed to the Government engaging directly or indirectly in business in competition with established agencies, and I am very glad to be able to report that such action was taken and a report of the chamber of commerce meeting will be given you this afternoon by one of our representatives, O. P. Deluse.

The farm board is not the only matter with which the country grain dealer needs concern himself in looking to the future. He must get along with his

competitor. He cannot get away from competition. He must in all his dealings with his competitors be fair and square. He cannot double-cross him. No person should be in the country grain buying business who is so selfish he cannot stand to see his competitor do a profitable business, or who cannot put confidence in his fellowman. It is not always possible to agree in politics or in religion, but it is seldom that business men cannot agree if they are but willing to meet the other half way. No one is in business just for his health or for pastime, but to make a return upon his invested capital and to supply a needed service in the community. It is not only far more profitable, but a great deal more pleasant, when men engaged in the same line of business agree to operate on a business basis rather than on the idea of personal animosity. The chief trouble with the country elevators is that there are so many that will not permit themselves to see this. I have always held to the belief that local meetings are the real ground work of our organization, and I dare say that no one has, during the past few years, worked harder than myself to get the dealers to take an interest in these meetings or to promote more friendly relations between everybody in the trade. In some respects I have met with success, but in the most important factor to the success I had hoped for, I have not, namely, in getting the dealers to affiliate with our organization, and I would like to suggest that at some session of this convention time be taken to discuss means for the building up of the membership of the association, for it is only through the dues of the members that the necessary finances to carry on this work are to be had.

During the year we have advised the membership from time to time, through bulletins, of those matters affecting them as grain dealers; attended to the ordinary routine of association work, and the publishing



W. E. CULBERTSON

of our thirty-seventh annual directory; adjusted disputes and misunderstandings between members; have suffered a slight loss in membership yet maintained our finances practically the same as a year ago, as you will note from the following statement:

Receipts

Balance on hand May 1, 1929.....	\$1035.04
Membership dues	\$5100.00
Directory advertising	1855.00
Sale of directories.....	55.00
Total	\$7010.00

Disbursements

Postage	\$ 267.59
Annual convention	89.25
Office rent	100.00
Telegraph, telephone and express....	56.43
Officer's expense	12.00
Printing	34.75
Office supplies	37.96
Secretary's expense	651.79
Printing of annual directory.....	\$25.70
Dues to National Association.....	220.00
Dues to Chamber of Commerce of the U. S. A.	30.00
Salaries	4695.00
Total	\$7020.47

Balance on hand May 1, 1930..... \$1024.57

In conclusion I want to thank the officers and members for the splendid co-operation given me at all times, and especially for their sympathy and consideration while I have been an invalid.

The treasurer's report was read by M. J. Porterfield and is contained in substance in the secretary's report. It showed a balance on hand of \$1,024.57 on May 1, 1930, as compared with \$1,035.04 on hand last year at the same time.

Harry Allen followed with the report of the finance committee after which B. P. Hill, chairman of the executive committee, gave the shortest talk

of the convention. He said that the grain trade had been running so smoothly that the executive committee had held no meetings and therefore had nothing to report.

In the afternoon Millard R. Myers of Chicago, nationally known authority and writer on grain co-operatives, addressed the grain men on "Governmental Grain Activities."

"While the independent grain dealers of Illinois have always looked upon farmers elevators as keen competitors in local trading territories, they realize that a pooling program such as that being forwarded by the federal farm board, which would take away local control of the farmer elevators, would at the same time jeopardize their own business," he said.

Mr. Myers criticized co-operative Government marketing efforts based on individual farmer membership campaigns, stating that they are undermining farmers elevators, leaving nothing substantial in their place.

"The pools have so far been a failure" he said. "and there is a check for \$1,000 toward the foundation of a grain marketing institute if any man can show a successful grain pool which has not cost the farmers from one to 50 cents per bushel by returning them a lower average price than was paid by local grain buyers in their respective territories."

Opening his address with quotations made by both President Herbert Hoover and former-President Calvin Coolidge, that when a government enters any field of business, it closes the door of opportunity for everybody else. Mr. Myers said that is exactly what has happened in grain. "and we seem to be just started. Corporations with millions of bushels of grain on hand have been and are in fear of bankruptcy and confiscation. The same condition exists throughout the entire trade."

Explaining the failure of the Government farm board plan, Mr. Myers said that agricultural co-operatives must grow from small beginnings, and sighted such co-operative developments in England and Scotland which have lived more than 100 years, and are still sound.

Parallels to these in this country he pointed out, are the farmers elevators co-operatives in the surplus grain states, which are likewise sound, having been developed by farmers themselves, without high-powered promoters, membership dues or Government subsidies.

They have grown steadily in power and influence over a period of 30 years, he said, until now they represent an investment of \$100,000,000, at 5,000 grain stations, and are handling 700,000,000 bushels of grain annually.

The majority of farm board members, on the other hand, Mr. Myers stated, are of co-operative experience confined to pools and contract methods of marketing cotton, fruits and tobacco. Alexander Legge, chairman of the board, is a manufacturer of monopolistic experience while S. R. McKelvie, grain representative, is only a farm paper publisher.

The result, the speaker pointed out, is that the leaders of the Governmental grain activities, such as the Farmers National Grain Corporation and the Grain Stabilization Corporation, are directors of pools, equities and union marketing organizations.

"Independent grain dealers." Mr. Myers concluded, "like all others in business in agricultural communities, recognize that their success, now as always, depends on their ability to serve their community acceptably."

O. P. Deluse, president of the Indianapolis Board of Trade, and representative of that organization at the recent gathering of the United States Chamber of Commerce, gave some interesting sidelights on the chamber meeting. His talk follows in part:

O. P. DELUSE ADDRESS

After six or seven years of unprecedented prosperity and progress, our country together with the balance of the world has hit an economic depression which is the worst we have encountered in many years.

It came practically overnight, brought about by the cumulative effect of mass and speed production, efficiency to the extreme degree, and an unbalanced ratio of supply and demand. The stock market breakdown was only an indicator of the economic hurricane which has hit us squarely. Our contribution to this disturbance or collapse can be understood when we realize that with 10 per cent fewer workers in 1928 than in 1919 there was an increase of 32 per cent in industrial output.

Between 1923 and 1928, out of 17 leading industries only two, the electrical and automobile, showed an increase in employment. The 24,000,000 autos wrecked the street cars and interurbans and hit the railroads hard; electric heaters and cookers, oil burners, and hydro-electric power has nearly wrecked the coal industry; washing machines and electric ironers have made inroads on laundries. Radios, Frigidaires, autos, and modern luxury appliances bought on long time, or the instalment plan, not alone absorbed current earnings, but anticipated earnings for several years, and the shifting tendency to speculate in stocks, for quick action, not yield, has diverted real estate and fundamental investments.

Our per capita production in the case of agriculture has increased over 15 per cent through modern machinery and advanced farming ideas. And our business, that of the agricultural producer and distributor has suffered, not for six months, but for several years.

The depression being world-wide, foreign buyers are obtaining bargains and the oversupply, restless and necessary to liquidate, is being sold below cost of production by other nations. Wool, cotton, rubber, cop-

per, sugar, tin are at lowest levels and many producers have been driven to bankruptcy.

The politicians, seeking to carry out promises for farm relief, frequently made during the past few years, hurriedly passed the so-called farm relief bill. In order to refresh your memory, and that we may have a clear picture, I will call your attention to the fact that two bills were passed by congress and were vetoed by the president. Finally, the present law was passed, signed by the president, and is now effective. Under this law the farm board took office on July 15. The primary purpose of the act is stated in Section 1. It is very plain, and I will read it:

"Section 1 (a). That it is hereby declared to be the policy of congress to promote the effective merchandising of agricultural commodities in interstate and foreign commerce, so that the industry of agriculture will be placed on a basis of economic equality with other industries and to that end to protect, control, and stabilize the currents of interstate and foreign commerce in the marketing of agricultural commodities and their food products—

"(1) by minimizing speculation.

"(2) by preventing inefficient and wasteful methods of distribution.

"(3) by encouraging the organization of producers into effective associations or corporations under their own control for greater unity of effort in marketing and by promoting the establishment and financing of a farm marketing system of producer-owned and producer-controlled co-operative associations and other agencies.

"(4) by aiding in preventing and controlling surpluses in any agricultural commodity, through orderly production and distribution, so as to maintain advantageous domestic markets and prevent such surpluses from causing undue and excessive fluctuations or depressions in prices for the commodity."

To make effective this act, \$500,000,000 was appropriated by congress. Under the loan provisions of the act, the board may loan to established co-operatives money on commodities. It may also loan on facilities up to and not exceeding 80 per cent of the appraised value at a rate of interest not to exceed 4 per cent. 3% is the per cent rate on money that the board has loaned up to this time.

And upon this structure the farm board has setup a complete organization, including legal, financial, economic, and distributing service.

The chairman of the farm board some time ago was



O. P. DELUSE

quoted in *Forbes* magazine as having said, "Our fundamental purpose is to organize agriculture as other great industries are organized; to educate the farmer to the wisdom and profit of joining in a well-managed marketing agency."

What Has Happened?

Now, what has happened? The farm board set in motion machinery which was to organize co-operative elevators and create regional, state, and national organizations; admittedly, not alone in competition with independent distributors but with intent to urge farmers and producers to join the co-operative institutions and without consideration of the independent elevator men or distributors of grain.

Only those co-operative institutions which qualify under certain rules and regulations are admitted to the favored circle. To those institutions financial assistance will be advanced at a rate of interest not exceeding 4 per cent. But these institutions must sell or ship their grain to markets and elevators designated by the national association. The farmers have been urged by high-powered solicitors to sign a five-year contract to deliver their grain to the co-operative elevator of their community. He will be advanced certain sums on his grain delivered and will have to wait for final settlement until all grain is sold and the expenses of handling is deducted. In other words, the farmer and producer will again furnish the produce, livestock or grain, and wait for his final payment until settlement is made by the co-operative organization. The co-operative elevator will either hold the grain or ship it to points designated by the regional organization, which is under the control and direction of the national organization. After grain has moved through the hands of four or five organizations it is but natural to assume that the carrying charges, transfer fees, dockage, insurance, weighing charges and extra-ordinary overhead will consume much of the selling price.

It seems to me that the farmer will be paying a heavy tax for the privilege of having the Government indirectly in the grain business. The set-up is tremendously expensive, as anyone must realize. This enterprise will not be operated as economically as private business.

The farm board has not alone advanced millions and millions of dollars to co-operative institutions, but early this year went directly into the buying and selling of futures as well as cash grain. It is said that the Government at this time has over 100,000,000

bushels of wheat in storage and that they have traded in many millions of bushels in the future market. The mere presence of Government influence in the futures market depresses rather than stabilizes farm prices because it destroys the reliance of individual judgment as to values and it frightens from the market trading and speculative buying which can no longer venture its judgment in the face of the unknown and changing policies of the Government forces. The price of grain and other products continued to shrink and finally the farm board, in desperation, urged and recommended that the producers reduce their crops, or acreage, not less than 10 per cent. The board said production must be restricted. This is the last desperate attempt to reduce the crops in order that the price be increased and is an admittance that the immutable law of supply and demand is the only influence that can increase prices. And here we have a situation which is the very reverse of that policy which has guided the Government in the Department of Agriculture for the past 50 years, namely, to increase production through scientific methods of farming.

Farm Board Policies Unsound

There are two major reasons why the present set-up and policies of the farm relief board are unsound: (1) Prices cannot be forced upward in a world market or be in interference with the economic law of supply and demand; (2) the enormous investments of private capital in plants and distributing organizations throughout the country, conceded and admitted by the Federal Trade Commission to be the best grain marketing system in the world, must be considered. The men now engaged in the business, with their capital investments, properly fear the working of the act. It is admitted that in the long run we cannot compete with our Government, *although we are supporting and supplying the taxes and funds which are being used for our undoing!*

The farm board is not only the adviser, but it is the banker, builder, buyer, and seller and finally will be dictator of our industry. We should not lay down but we must fight this unjust, uneconomic movement.

The farmers, the producers, and even the co-operative institutions themselves will not endorse a movement calculated in its final analysis to destroy other industries and especially one which has served and which is necessary to their own progress. The law, in my judgment, is manifestly class legislation.

In my humble opinion, a greater service and assistance can be rendered to the farmers and producers by reducing their taxes and the cost of farm machinery and the commodities which they use in their business.

I think the time has come when we should take the farmer into our confidence, sit down with him and discuss this matter of farm relief as reflected in the bill. Recall his past experiences with grain pools and marketing organizations. Furnish him with data, information and facts. Give to the farmer every service. Let's fight for him and our own rights, defending what we have.

I am proud of our business. We have been the farmers' and producers' best friend throughout the years. We have given service, counsel and financial assistance and in every manner we have measured up to the highest standard of honorable business relations and ethics.

It is un-American to destroy or confiscate another's property without just compensation and I am sure that fair play and justice will finally prevail.

In the evening the convention banquet was held in the Masonic Temple. The entertainment during the dinner was rather unusual, featuring several select dances by members of Miss Annette Van Dyke's pupils at the Millikin Conservatory of Music in Decatur.

FINAL SESSION

The final day's session opened at 9 a. m. Wednesday with a talk, illustrated with stereoptican slides, by a representative of the Federal Grain Inspection headquarters. He was followed by Lacey F. Rickey, associate in grain marketing at the University of Illinois, whose address covered the different phases of marketing grain.

Charles Quinn continued his attack on the farm board's "unsound economic" policies, declaring it the "horns of a dilemma". He pictured the board as being in a hopeless situation.

J. A. Schmitz, weighmaster of the Chicago Board of Trade, concluded the convention talk's, speaking on scales. It follows:

J. A. SCHMITZ' ADDRESS

"Weighed in the balance and found correct." No doubt all of us would be pleased to have such a report made about our every action. From our earliest knowledge of the doings of the ancients we learn that the demand for correct, just, weights has gone hand in hand with the demand for justice; politically and religiously. Fair dealing in all things has always meant correct weights, even back in the dark ages when weights and scales were most primitive, the knowledge of weighing apparatus was small and the standard units of weight was even more arbitrarily fixed than now. Yet, then as now, weights and scales were major subjects, much discussed, although, because of the limitations of both the scales and the weights, there use was largely restricted to the weighing of gems and precious metals. Very early in the history of mankind we find the scale used as a symbol to depict Justice; "honest weight" meant "just weight," neither too much nor too little. A just weight was one that gave the exact value of the thing weighed within the limits for accuracy of both scale and weights. Now, while the jewelers and money dealers were using the scale in their commercial transactions, the philosophers and priests made use of the balance and the weights in an allegorical way to illustrate the measurement of things spiritual and moral. The gods of those times were pictured as measuring the achievements and spiritual qualities of the new entrants into the celestial kingdom by the balance. And, in connection with the use of these instruments, special emphasis was placed on the fairness of the weighings and on the correctness of the balance for we have from ancient literature the following:

"I have not taken from the balance."
"I have not nullified the plummet of the scale."
The quotation frequently made that a false weight is an abomination to the Lord, finds ready acclaim even in this busy prosaic age.

It may be somewhat surprising that so little progress in weighing was made during all the years that

May 15, 1930

have followed its first use. However, a scale is a machine and therefore its progress had to await the coming of the machine age. The first written historical record which we have of the progress of weighing is in the bible in the story in which Abraham purchased a burial place for his wife, Sarah, from the Sons of Heth for 400 shekels which were weighed in the balance. This shekel was a predetermined weight.

Rapid Progress in Late Years

In the last 25 years, progress in scales has been so rapid that often well cared for scales became obsolete before they reached old age. Scales are no longer in the vanguard, they are in the front ranks, for now we have a scale for every need, scales that will weigh, within a small tolerance, the largest locomotive, and scales that are so sensitive that we have difficulty in securing men whose touch is fine enough to operate them. So much for scales.

Now, concerning the art of weighing. Needless to say, good scales are essential to correct weights. However, accurate scales alone do not assure correct weights, for unless certain essential duties are performed in connection with the physical operation of a scale, the weighing results will be unsatisfactory. What these essential duties are depend upon the commodity that is to be weighed and upon the condition under which the weights are to be obtained. For instance, "accurate weight" in the case of grain means the weighing of all the grain contained in the car. Should such a car be weighed on a track scale, the tare weight must be as accurately weighed as in the gross, and unless this is so and unless all the grain is first removed from the car, and all the cooperating material removed in the process of unloading is returned to the car to assure a correct tare weight, the weight arrived at will not be accurate. What I wish to convey is, that no matter how close the reading of the weight recording mechanism of a scale may be, "correct weight" is not secured unless you perform each of these other essential tasks.

The primary functions of a department of weighing such as is maintained by the Chicago Board of Trade is to modernize the facilities and to improve the

to a much greater extent to the bad effect of rust and the maintenance cost is therefore excessive. On the other hand, if in addition to a well-drained pit, a shelter shed or other covering is provided for the scale, and the main bearings are packed with grease, its life will be greatly prolonged and its continued accuracy will be very much extended. The maintenance cost of such a scale will be reduced to the minimum of the actual wear of the scale parts, and the effect of rust will become a minor rather than a major matter.

Inadequate foundation: Much has been said and written about the need of adequate foundations, and yet, it would appear that in spite of the many admonitions concerning this important item there is still a tendency to under-rate the importance of solid foundations, carried down to or below the frost line. Then too, the matter of providing a solid base upon which to place the scale beam and its fixtures is another item that is all too often overlooked. Let it be emphasized here, that solid unyielding bases must be provided for all scale parts, otherwise permanent accuracy cannot be expected.

Improper setting and poor workmanship in assembling: Just as the level of the levers is important, so is also the plumb of their connections indispensable to the accuracy of scales. Careless installation and setting of scales make for inaccurate weights. The best type and make of scales will not weigh accurately unless all the parts are properly assembled.

Lack of care and maintenance: All scales, irrespective of manufacture or kind must be accorded a certain amount of care and attention. All too often scales are almost entirely neglected, it being assumed that when installed they will continue to function practically until the end of time, and such items as cleaning and inspecting the various scale parts and platforms are left for the too infrequent visits of the scale inspector. Accumulations of dirt hasten rapid deterioration of the scale parts.

In conclusion, let me say that like care in the selection, installation and maintenance, should be given all other scales in so far as the suggestions made are applicable to them.

Following a "round table" discussion of the problems of the country grain dealer and committee reports, new officers were elected, after which the convention adjourned.

Convention Notes

THOMAS LAMB of Bement, Ill., 83 years old, and for 27 years manager of the local Lamb elevator, was the patriarch of the convention. He was forced to stand and receive the greetings of the assembled membership.

* * *

DECATUR'S three golf courses—the Country Club, Sunnyside Club, and Southside Club—were open to the visiting delegates and over half of them made arrangements to play at least one round. Members of the association were also admitted to the Decatur Club and the local Elks Club.

* * *

SECRETARY W. E. CULBERTSON was so far recovered from his fractured leg, caused by a fall on the ice last winter, that he was able to appear on crutches. He was warmly welcomed when he arrived.

* * *

OVER 400 members registered at the Hotel Orlando, convention headquarters. This is about the same number that attended the 1929 gathering, held May 14 and 15 in Peoria.

* * *

REAL summer weather prevailed during the entire meeting, the thermometer hovering above 80 almost all the time except in the evenings which were warm enough to make walking and driving a pleasure.

* * *

C. L. CANNON'S representative, speaking on the final day, said there are three commandments for car inspection—even loading, no high loading, and no plugged cars.

* * *

YOU can't keep a good man in the background and Charles Quinn, who is secretary of the Grain and Feed Dealers National Association and has been for the past 17 years, was given his chance to flay the Federal Farm Board which he did with accustomed vigor.

* * *

AMONG those who contributed to the evening's entertaining during and following the banquet on May 6 were Miss Helen Rice, the Crough Brothers, the Aeolian quartet, Bradshaw and Miller, Rollin Staley, Miss Janeth Meredith and the dancing class of Miss Annette Van Dyke.

* * *

DIRECTORS held over from last year are B. P. Hill, N. L. Hubbard, L. B. Walton, C. T. Rees, and G. E. Mellen.

* * *

BUSINESS sessions were held in the ball room of the Hotel Orlando, there being one at 10 a. m. and another at 2:30 p. m. on Tuesday, and the concluding one at 9 a. m. on Wednesday. The banquet was held in the Masonic Temple.

* * *

ACCORDING to figures given out by the Decatur Chamber of Commerce, more than 96,000,000 bushels of corn are grown within a radius of 80 miles of Decatur annually. More than 50,000 bushels of corn are ground daily in Decatur mills.

* * *

HOSTS at the convention were the Decatur Milling Company, Evans Elevator Company, Hight Ele-

vator Company, J. C. Schaffer Grain Company, Shellabarger Grain Products Company, A. E. Staley Manufacturing Company, and the Union Iron Works.

* * *

A SPECIAL bridge luncheon was given at the Sunnyside Golf Club Tuesday afternoon, May 6, for the ladies. A tour of the city for all delegates was arranged for late in the afternoon of the same day.

* * *

IN WELCOMING the delegates, Mayor Smith warned the convention that the local police department had just purchased a new, commodious patrol wagon and pointed with pride to a large artificial fresh water lake within the city limits. He suggested that the members draw their own conclusions. His talk was full of humor and good will and was enthusiastically received.

THE BEMENT GRAIN COMPANY—A CO-OPERATIVE

By THOMAS LAMB

Oldest Member Illinois Grain Dealers Association

The Bement Grain Company opened its offices for business January 1, 1903. As its business grew it bought the plant in Bement, Ill., of a private competitor and later built a new elevator, equipped it with all necessary machinery. It even erected a house for the manager, three miles east of town near a Wabash switching point. The co-operative law was passed in 1915 and in 1919 the Bement Grain Company voted to become a co-operative.

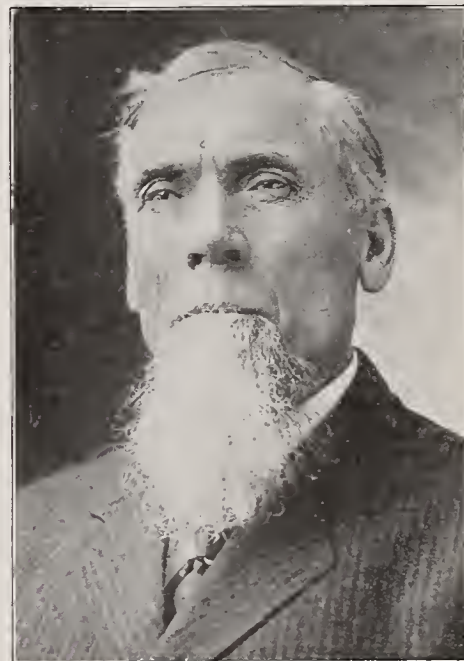

THOMAS LAMB
Manager of the Bement Grain Company

Under its new charter it has prospered and has rendered a true co-operative marketing service to its members.

In 27 years of business, the company has handled in excess of 400,000 bushels of grain a year. It has paid 167 per cent on its capital stock and 150 per cent in stock dividends. It has paid out in patronage dividends during the 11 years of co-operative service, \$28,000, an average of over \$2,000 per annum; this is in addition to the annual dividend of 6 per cent on the capital stock.

The Bement company can point with pride to its record of business which shows a well-balanced financial condition that qualifies it for true co-operative service. It should be borne in mind that a co-operative concern is run by and for the producers of grain. Among the distinguishing points is an ample but reasonable issue of capital stock. This assures against an excess of profit being paid to capital. The same applies to the limitation of dividends paid to capital. The patronage dividend is the reward that comes to the grain producer whose interests the co-operative organization is ordained to promote. The private dealer emphasizes the margin upon which business is run. It is important, but co-operatives insist that the equitable distribution of profits is the cornerstone of co-operation. If the Bement Grain Company had been run as a private concern, the \$28,000 which it returned to grain producers would have gone as a private profit into the bank account of the private dealer.

FOREIGN oats imported to Sweden, it is reported, will be dyed red under a proposed regulation of the government.

SUPPLIES of wheat in foreign producing countries are nearly 300,000,000 bushels less this month than in February, 1929.



J. A. SCHMITZ

methods used in handling and weighing grain to and from cars, to the end, that weights independent of the interests of either party to a transaction will be available for settlement purposes. Plainly, it is the duty of the weighing department chief in regulating the details of his office and employees to see that regulations are adopted and enforced that are requisite to protect all interests concerned. Be it remembered that the shipper by selling his grain on the basis of terminal weights assume the liability of loss through possible leakage and theft in transit as well as possible errors, waste and bad practices at the terminal points of weighing. It is the shipper's right therefore to demand the use of modern equipment and modern methods when weighing his grain at points where settlement weights are determined. On the other hand, while a weighmaster is not by any means always irrepensible in the matter of shortage, he may often be unjustly blamed. A terminal grain weighing bureau may properly be termed a "trouble department" in the sense that it comes in contact with many of the troubles to which the grain trade falls heir. Many of these troubles, in varying degrees of severity, will always be with us, but the causes of some of them can and ought to be remedied. A discussion, in detail, of all of the various items that have a bearing on weights and weighing would consume more time than is allotted this morning. I do, however, wish to briefly touch upon several things I deem especially important and that is the selection, installation and care of wagons and motor truck scales.

The question often asked, concerning this type of scale, "What is most important, correct installation or proper maintenance and care?" is, in reality, not debatable, for unless both of these subjects are handled with equal importance, satisfactory weights are not assured. While it is true that sometimes well installed and properly located scales will give good weighing results without proper care, and, while it is also true that sometimes the effects of poor installation are in a measure counteracted by careful maintenance and care, provided, that the errors in installation are not of a character that preclude accuracy, continued, permanent, satisfactory performance of these scales is not assured unless well selected and properly designed scales are correctly installed, and further that they are carefully maintained.

Most Common Errors

The most common errors in installation may be briefly classified as follows:

Poor location: Scales so located that the scale pits cannot be properly drained. Such scales are subjected

ASSOCIATIONS

KANSAS GRAIN DEALERS PLAN SUMMER MEETING

The grain dealers' pet antipathy—the Federal Farm Board—is scheduled to receive proper attention at the thirty-third annual convention of the Kansas Grain Dealers Association in Hutchinson, Kan., May 20 and 21. Not only the speakers but the entire group of members in attendance will be given an opportunity to divulge their opinions for all subjects are open to "pertinent discussion."

It is planned to open the program with an address of welcome by George Gano, president of the Hutchinson Board of Trade, after which Roy W. Cox will present the thanks of the visiting association. With these details disposed of, the business of the convention will begin, President J. H. Voss of Downs, Kan., reading the president's annual address, and E. J. Smiley the secretary's report. Opening day talks include those by John Fields, president of the Federal Land Bank at Wichita, C. D. Morris of the Western Railroad Committee, and Ted Branson, president of the Salina Board of Trade.

Speakers on the second day's program with their subjects include "The Problems Facing Purchasers of Mortgaged Grain," by A. L. Oswald, and "How to Meet Present Day Conditions and Why Elevator Companies Fail," by W. G. Hopkins. The resolutions of the National Chamber of Commerce of the United States will be presented by J. J. Kraettli. A three-reel motion picture showing vividly every process of the handling of a car of grain from the time it is loaded at country elevators until it is discharged on board ship will follow. R. D. Jarboe, Federal Grain Supervisor, who explains the pictures, declares it is a "four star" production.

Committee reports and election of officers will conclude the convention program.

MC DOWELL MADE HEAD OF CALIFORNIA GRAIN GROUP

Gail M. McDowell, well-known Pacific Coast grain and feed man, was elected president of the California Hay, Grain & Feed Dealers Association at the sixth annual convention in Los Angeles, April 25 and 26, succeeding Edward L. Dial. L. V. Korvel was chosen vice-president and I. J. Strommes secretary for the ensuing year. The new directors were chosen as follows:

Grain division: J. B. Outseen, G. B. Hill, and T. V. Cox; feed division: George Anderson, H. N. Laine, and Ralph Boone; hay division: W. E. Starr, C. E. Berringer, and Gordon Russell.

E. L. Dial of San Francisco was in the chair at the opening session, reporting the year's association activities and outlining future progress. H. L. Laine of Los Angeles reported that 40 new members had been secured during the year.

Barley and wheat are now being harvested in the Imperial Valley, and the condition of these two grain crops, with Alfalfa hay, is of the utmost economic importance and interest to every member, as well as to farmers and bankers. A very comprehensive report was presented by Philip O'Connell, for J. W. Schuler, Stockton.

Henry G. Turner, president of the Grange Company, Modesto, reported on the subject of clean seed, reflecting the work of the California Seed Council.

The report of the mixed feed committee was presented by Mr. Corbell, for George B. Murphy, committee chairman, of Petaluma. The report as accepted recommended that all ingredients listed on the tag should appear in the order in which they predominate; that feeding directions or advertising may now be printed on reverse side of analysis tags, and that copies of analyses of all samples collected by the state from any manufacturer would be furnished said manufacturer on request, if desired. It was the unanimous opinion that the enforcement of the feedings act should not be transferred from the state board of health to the department of agriculture.

Francis E. Whitmer of San Jose gave a very interesting and comprehensive report on credits and the bankers' analysis of financial statements.

The hay conference report was presented by D. Macaulay, chairman of the hay committee. The committee recommended some changes in the uniform hay contract, reported the progress of Federal hay inspectors and told of the work of local committees that have been appointed to investigate dairy conditions, such as butter fat values, contagious diseases, etc. Conditional sales contracts, ex-

tension of credits and other problems affecting the marketing of hay were reviewed.

Mr. O'Connell, presenting the grain conference report, said: "The committee recommends that this association work in conjunction with the California Warehousemen's Association toward ridding country warehouses of weevil; that all warehouses of the state be asked to cooperate with both associations toward that end; that every endeavor should be made by warehouses to see that all old crop weevil-infested lots of grain are moved out. We feel that warehouses should take advantage of this request before more drastic measures are taken by legislative means."

The convention convened again Saturday morning with the following special committee reports: H. N. Maddaford, on the California Economic Research Council; O. H. Blassingham, uniform contracts committee report; D. Macaulay, state and national legislation, and Welles T. Ross, on the California Hay, Grain and Feed Dealers' Association recordation measure test case, which has just been appealed to the supreme court.

FEED MANUFACTURERS MEET MAY 22 TO 24

Delegates to the twenty-second annual convention of the American Feed Manufacturers Association to be held at the French Lick Springs Hotel, French Lick, Ind., will not be weighed down under numerous business sessions. During the three-day meeting, from May 22 to 24, there will be no afternoon or evening sessions, all business being transacted in the morning prior to 12:30, which has been set as the "deadline" for adjournment. All sessions are open to the public and anyone interested in any angle of the feed industry will be welcome.

President D. W. McMillen of Fort Wayne, Ind., will open the convention with the annual address by the president to be followed by the reports of Secretary L. F. Brown, Treasurer W. R. Anderson, and Traffic Manager R. M. Field. Arthur W. Clark of Geneva, N. Y., is also on the opening day program, his talk being on "Present Day Feed Problems." There will be discussions on these addresses and reports until adjournment. At 8 p. m. the annual banquet will be held, featuring Captain T. Dinsmore Upton of Muskegon, Mich., whose subject will be "Funny Side Up."

The Friday morning session will convene at 10 a. m., the first speaker being R. M. Bothke of Wooster, Ohio, in charge of nutrition investigation at the Ohio Agricultural Experiment Station. His talk, "The Place of Minerals in Poultry Feeding," will be followed by an address by Henry A. Wallace of Des Moines, Iowa, editor of *Wallace's Farmer* and *Iowa Homestead*. "Even This Shall Pass Away." Again there will be discussion until 12:30 when everyone will pack up their golf bags and journey to the local country club to compete in the annual association golf tournament. While the men are doing this the ladies' bridge party will be in progress.

No talks of especial importance are on the Saturday business schedule which will conclude with the election of officers, followed by meetings of the newly elected board of directors and executive committee for organization.

The association is endeavoring to secure reduced railroad rates on the certificate plan which would mean a 50 per cent reduction in train fare provided 150 certificates are issued.

WESTERN GRAIN DEALERS HOLD THIRTIETH ANNUAL MEETING

J. R. Howard, former president of the Federal Farm Bureau and now special representative of the farm board, told members of the Western Grain Dealers Association at their thirtieth annual convention in Des Moines, Iowa, April 28 and 29, that the world has gone "wheat wild" in the face of decreasing consumptive demand. Recounting increased production figures from Europe, Canada, Australia, and South America, Mr. Howard said:

"We may still be able to export small amounts for another year or two, but the prospect of any material volume is a mirage. The good old days of supplying a world market are gone because the market is gone. Thus it is evident that we must cut production to about domestic needs or accept a feed value price for all our wheat. A 200,000,000-bushel surplus of wheat used for feed in competi-

tion with corn might change the agricultural geography of the nation."

Mr. Howard's talk, coming on the last day of the meeting, stirred up considerable comment. Certain members felt that Mr. Howard, who is a native of Iowa, is naturally "corn-minded" and so cannot see a bright future for wheat. Others sided with the speaker, feeling there is much truth in his remarks.

The convention, which was held in the Hotel Fort Des Moines, brought out a good attendance of grain men throughout the West. Many good speakers were on the program, including, in addition to Mr. Howard, Bert T. Dow, president of the Grain and Feed Dealers National Association, W. B. Combs of the Federal Grain Department, J. A. Schmitz, R. C. Bentley of Ames College, and C. Vincent of the Omaha Grain Exchange.

The Monday business session opened with an address of welcome by George Hamilton, secretary of the Des Moines convention bureau, followed by the president's annual address, delivered by H. W. Talbott. D. O. Milligan then read his report as secretary-treasurer. After the appointment of committees the meeting adjourned until afternoon when talks by N. H. Mongeau, manager of the Farmers Elevator Company, Elmore, Minn., on the Minnesota storage law and its operation, and by W. B. Combs on "Grain Inspection Equipment" were heard. C. Vincent was also on the afternoon program, speaking on "Orderly Marketing of Grain." The day's session concluded with a general discussion.

Dining and dancing followed in the evening in the main ball room of the hotel. Arthur Brayton, editor of the *Merchants Trade Journal*, gave what he called a "pep" address, after which the Grain Dealers Minstrel, under the direction of Leon Garber, performed.

The final day's session came to order at 9:30 a. m., the first speaker being J. A. Schmitz, weighmaster of the Chicago Board of Trade, whose topic was "Scales and Scales Inspection." R. C. Bentley discussed the "Intra-State Movement of Grain from Surplus to Deficit Areas," after which a survey of electric power voltage and power costs in Iowa elevators was presented by J. C. Westerfield, insurance expert. Transportation problems came in for consideration at the afternoon session and formed the subject of an address by C. D. Morris, railroad official. The concluding talk, which stimulated so much comment, was then delivered by Mr. Howard.

Association Briefs

THE Northwestern Ohio Farmers Grain Dealers Association held its regular monthly meeting in Fostoria on May 5. Oscar Slosser, who heads the state company organized to handle the farm board affairs in Ohio, was host for the evening.

FORMAL announcement of the fifty-second annual meeting of the Ohio Grain, Mill and Feed Dealers Association has been made by W. W. Cummings, secretary. Headquarters will be in the Commodore Perry where special convention rates have been secured. The date is June 19 and 20, and many fine speakers are on the program.

MEMBERS of the Topeka Board of Trade joined in a meeting of country grain dealers called by E. J. Smiley, secretary of the Kansas Grain Dealers Association, at the Hotel Kansan, April 17.

THE Nebraska Grain Dealers Association is holding a series of meetings in different sections of the state for the purpose of giving information on grain grading and other problems of the country dealers. Meetings are being attended by both country dealers and terminal market representatives.

A GOOD attendance was reported at the thirtieth annual convention of the Western Grain Dealers Association at the Hotel Fort Des Moines in Des Moines, Iowa, April 28 and 29.

THE Indiana Grain Dealers Association, through Secretary Sale, announces that members may obtain the Government bulletin, "Control of Insect Pests in Stored Grain" by writing association headquarters at Indianapolis. It was from this bulletin that the article, "The Unseen Foe of Stored Grain," which appeared in last month's *American Elevator* and *Grain Trade*, was prepared.

VERY fancy affairs, these invitations to the twenty-second annual American Feed Manufacturers Association convention at French Lick, Ind., May 22 to 24. Secretary Brown has even included the conventional "R. S. V. P." which gives the appearance of a wedding invitation or something equally as tragic.

GETTING cut rates for railroad fares to various convention points is usually more difficult in the summer than it is during the colder parts of the year, for a great number of the attending members

May 15, 1930

prefer to drive rather than go by train. This often makes it impossible to get the required quota—150—which the railroads demand before reduced fares can be secured.

W. O. SAND, secretary of the Farmers Co-operative Grain Dealers Association, has returned home after completing his audit of the Cimarron Co-operative Exchange.

THE Panhandle Grain Dealers Association holds its annual convention in Amarillo, May 22. The Oklahoma Grain Dealers Association will convene at Enid, May 23 and 24, and the Texas Grain Dealers Association will meet in Fort Worth, May 26 and 27.

FOR complete details of the coming convention of the American Feed Manufacturers Association at French Lick, Ind., May 22 to 24, see preceding page.

FABLE: Once there was a 1930 convention where nobody had anything to say about the Federal Farm Board and its policies.

"ALL subjects are open to pertinent discussion," says the tentative program for the Kansas Grain Dealers Association meeting this month, thus giving the boys in the rear a chance to say something besides, "I second that motion."

GRAIN men failing to attend meetings of their associations this summer are passing up a chance to swap views on the current topic of conversation, the F. F. B.

THAT mid-year convention of the Indiana Grain Dealers Association is getting closer all the time—if you don't believe it, consult your calendar. The time is June 18 and the place is Indianapolis. An attendance of 350 is hoped for.

CONVENTION CALENDAR

May 20-21:—Kansas Grain Dealers Association meets in Hutchinson, Kan.

May 22:—The Panhandle Grain Dealers Association meets in Amarillo, Texas.

May 22-24:—American Feed Manufacturers Association meets in French Lick Springs Hotel, French Lick, Ind.

May 23-24:—Grain Dealers Association of Oklahoma meets in Enid, Okla.

May 26-27:—Texas Grain Dealers Association meets in Fort Worth, Texas.

May 27-29:—Pacific Coast Seedsmen Association meets in Hotel Huntington, Pasadena, Calif.

June 13-14:—Pacific Northwest Grain Dealers Association meets in Lewiston, Idaho.

June 16-17:—Montana Farmers & Independent Grain Dealers Association meets in Havre, Mont.

June 16-17:—Central Retail Feed Association meets in Schroeder Hotel, Milwaukee, Wis.

June 18:—Indiana Grain Dealers Association meets in Indianapolis, Ind.

June 19-20:—Ohio Grain, Mill and Feed Dealers Association meets in the Commodore Perry Hotel, Toledo, Ohio.

June 19-21:—Southern Seedmen's Association meets in the John Marshall Hotel, Richmond, Va.

June 23-24:—Farm Seed Association of North America meets in King Edward Hotel, Toronto, Ont.

June 25-27:—American Seed Trade Association meets in the King Edward Hotel, Toronto, Ont.

July 7-8:—National Hay Association meets in Columbus, Ohio.

October 12:—Terminal Grain Weighmaster Association meets in Hotel Sherman, Chicago, Ill.

October 13-15:—Grain and Feed Dealers National Association meets in Hotel Sherman, Chicago, Ill.

October 14:—Chief Grain Inspectors National Association meets in Hotel Sherman, Chicago, Ill.

AFRICAN WHEAT DUTIES UP

Effective this season the Union of South Africa minimum tariff rates on imported wheat, applying to imports from Canada and the United Kingdom, were increased to two shillings per 100 pounds. S. H. Day, American trade commissioner at Johannesburg, reports further, through the United States Department of Commerce that the maximum tariff rate on wheat applying to imports from this country are increased to 2/2 (two shillings and two pence) per 100 pounds.

BREWERY barley duties, as well as wheat tariffs were increased in Germany, effective April 25, 1930, to \$3.57 per 220.4 pounds.

GRAIN TRADE PATENTS

Bearing Date of April 15, 1930

Feed Grinder. Tom Tamen, Lakota, Iowa. Filed July 23, 1928. No. 1,755,037. See cut.

Claim: A grinding device comprising a pair of spaced discs having laterally projecting teeth in an interfitting relation, each disc being divided uniformly into sections, said teeth being arranged in concentric circles with the teeth in each circle being uniformly spaced, each section having an initial series of teeth on each section being arranged in a straight line trans-

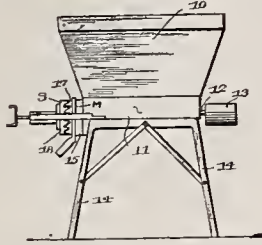

versely of the concentric rows, the succeeding teeth in the innermost concentric rows being disposed in staggered relation with the teeth succeeding the initial series in the outer concentric rows, the leading edge of each tooth being sheared off at an angle.

Roll Construction for Grist Mills. Edwin A. Hall, Daggett, Mich. Filed April 20, 1928. No. 1,754,270. See cut.

Claim: In a roll construction for grinding mills, a pair of parallel spaced non-circular shafts, a reduced threaded spindle formed on each end of each shaft, a plurality of independent operatively beveled disks, arranged on one shaft, a pair of end disks arranged on said shaft, the inner face only of each end disk being beveled, a series of oppositely beveled independent disks arranged on the other shaft for alternately

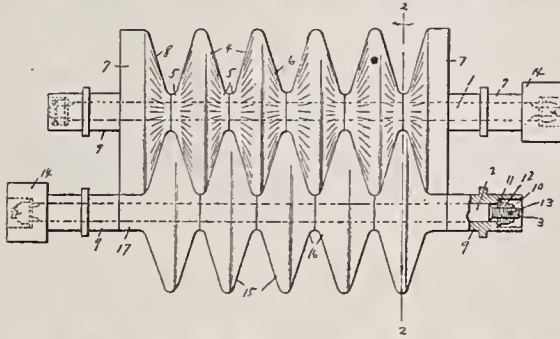

fitting between the disks on the first mentioned shaft, the end disks of the second series having hub extensions on the outer side thereof with which the peripheral edges of the endmost disks of the first mentioned series engage, sleeves having non-circular bores disposed over the respective ends of each shaft, the outer end of each sleeve being formed with an enlarged socket into which the respective spindle extends, a ring surrounding each spindle in each of the sockets, and a nut threaded on each spindle to hold the respective ring against the inner end of the respective sockets as and for the purpose described.

Bearing Date of April 22, 1930

Method of and mechanism for grinding and separating materials. Walter J. Clement, Utica, N. Y., assignor to the Bossert Corporation, Utica, N. Y., a corporation of New York. Filed April 7, 1928. No. 1,755,573. See cut.

Claims: 1. A mechanism of the class described comprising a substantially cylindrical casing, a rotary shaft arranged coaxially of said casing, a plurality of hammers carried by said shaft to swing in circular paths in said casing and adjacent to the inner face thereof, said casing having its inner face extending outwardly beyond its cylindrical outline through a portion of its

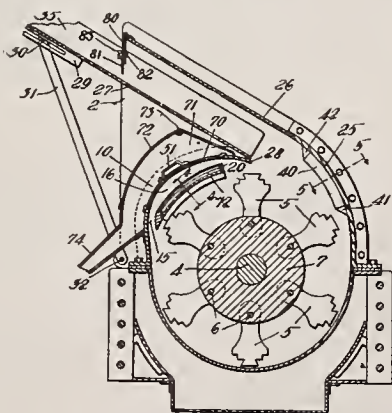

circumference, a duct extending lengthwise within said casing out of the paths of said hammers at said outwardly extended portion and defining therewith a passage for material out of the path of said hammers, the outer face of said duct having openings through which material in said passage may be drawn, and means for exhausting air from said duct.

Bearing Date of April 29, 1930

Method of treating alfalfa, clover, and other hard-shelled seeds to promote prompt germination and remove weed seeds therefrom. Harry R. Warren, Chicago, Ill., assignor to Warren-Teed Seed Company, Chicago, Ill., a corporation of Nevada. Filed November 15, 1928. No. 1,756,497.

Claim: In a method of treating seeds of the same kind but of varying degrees of hardness to secure uniform germination, the steps of soaking the seeds in a glucose solution, separating out the seeds that are

swelled by such soaking, moderately scarifying the remaining seeds, soaking the scarified seeds in a glucose solution, separating out the seeds that are swelled by such second soaking, and drying the separated seeds, whereby a glucose coating is left thereon.

Grain-cleaning process and machine. Thomas E. Forster, Wichita, Kan., assignor by direct and mesne assignments to the Forster Manufacturing Company, Wichita, Kan., a corporation of Kansas. Filed December 22, 1927. No. 1,756,246. See cut.

Claim: A process of cleaning smut and the like from grain comprising the steps of producing a high-velocity air current in a cylinder having a smooth imperforate inner surface and violently whirling said current circumferentially of the cylinder, feeding grain into said cylin-

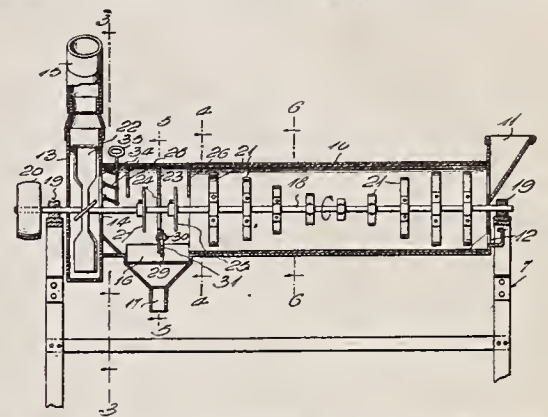

der, and relatively controlling the air current and the grain feeding to cause all of the individual grains to be violently whirled and carried in suspension by said current.

Method of treating seeds to secure uniform germination. John L. Kellogg, Chicago, Ill., assignor to Warren-Teed Seed Company, Chicago, Ill., a corporation of Nevada. Filed November 15, 1928. No. 1,756,488.

Claim: In a method of treating seeds of the same kind, but of varying degrees of hardness, to secure uniform germination, the steps of soaking the seeds in a color-fixing liquid, separating out the seeds that swell as the result of such soaking, scarifying the remaining seeds in the presence of a liquid, soaking the scarified seeds, and then separating out the seeds that swell as the result of said last soaking.

GRAIN WORLD

A FEDERAL CORN BOARD

The Berlin office of the United States Department of Commerce reports that in connection with the German Reichstag's farm relief program, a corn monopoly has been established by the government. Corn grown in Germany or corn imported from abroad may be handled, under the terms of the act only by the Federal Corn Board.

This regulation applies to ground corn and shredded corn, as well as to the whole grain. A concern which desires to sell imported or inland corn must offer it to the Federal Farm Board; this applies also to a concern which wants to use corn for manufacturing purposes, i.e. for the manufacture of starch, the distillation of alcohol, etc.

The Federal Farm Board must purchase corn from merchants and co-operative societies. In exceptional cases only is the Board allowed to import corn direct. For the purchase of corn the Federal Corn Board has to pay a reasonable price. If necessary an arbitration court decides finally whether the price offered by the board is reasonable or not. Exportation of corn is allowed only with permission of the Federal Corn Board.

The government is to fix the sales price of corn. It is also entitled to fix minimum quantities of corn to be sold to single purchasers. As long as this law is in force, the autonomous tariff rate for corn is 2.50 marks per 100 kilos. The corn law is effective this spring, and remains in force for two years, i.e. until March 31, 1932, unless extended by the government.

ITALY'S WHEAT IMPORTS

Trade Commissioner Spencer at Milan reports that the Italian director-general of customs announces that imports of wheat for the first nine months of the present grain year have been 19,549,945 bushels ending with March 31, 1930. The amount of wheat imported in the same months of the preceding year was 62,006,970 bushels.

The record wheat crop that Italy produced in the past year is, of course, responsible for this decrease in imports of this food commodity. Since Italy's average annual imports are about 84,000,000 bushels of wheat, it is apparent that even if the normal quantity is imported in the three remaining months of this year, which seems most improbable, Italy will have reduced her imports by at least 50 per cent.

A MINISTERIAL ordinance published April 25 in Berlin extended the ban on imports of American barley until December 31 of this year. The ban is not applicable, however, to No. 2 barley from Canada or from certain sections of the United States.

THE final estimate for the Argentine wheat crop is 135,938,000 bushels; oats yielded 68,211,000 bushels; barley, 16,076,000; and rye, 4,330,000 bushels.

FIELD SEEDS

GOTHAM SEED SEASON ENDS WITH PRICES HIGHER

By C. K. TRAFTON

A "weather market" was the description frequently given by distributors of seeds in the New York market during the period under review, the volume of business being affected by freakish climatic changes. When conditions were adverse, however, they merely served to retard business temporarily, and actually caused some prolongation of the season. On the whole, as very satisfactory conditions prevailed ultimately, the season for spring seeds was generally reported as fully up to normal in virtually all respects.

As a consequence, stocks of nearly all descriptions were materially reduced, and as similar reports of generally light stocks came from all along the seaboard, holders maintained a very firm attitude right up to the close, there being no sign of the scalping which is sometimes witnessed toward the end of a season when the trade is anxious to avoid carrying over burdensome surpluses. As a matter of fact, with one or two exceptions, prices show gains of from one-quarter cent to five cents compared with those current a month ago. At the outset buying was delayed somewhat by rains, after which came a remarkable return of wintry weather with temperatures below freezing; in some cases at the lowest levels in 60 years, and with snow in some sections. With remarkable suddenness mid-summer weather appeared with the mercury at record-breaking altitudes.

On the whole, movement of seeds was reported as very general and as the demand for Clovers gradually slackened in this immediate vicinity, the call for grasses improved steadily. A continued good general inquiry from the New England states kept the market lively early in May after demand from more southerly sections had been largely satisfied.

Timothy, with a gain of 3 to 3½ cents, was the real leader as far as market interest was concerned. Increasingly emphatic reports were received regarding the extreme depletion of stocks in producing sections and as there was an unusual demand in all eastern markets stocks all along the seaboard were reduced materially. As a consequence holders have advanced to 10½ to 11 cents, and from present indications, as some authorities see it, it looks as though still higher prices might be seen before another crop is harvested. Exports for the period were about 1,235 bags, against about 1,325 for the previous period.

White Clover also advanced three cents, or to 28 cents, although arrivals increased to about 595 bags, against about 395 for the preceding month.

Red Clover, domestic, gained one-half cent, while imported is one cent higher, although the latter was the one item which failed to move as well as usual at this season. Arrivals were only about 350 bags, against 2,525 during the month previous.

MILWAUKEE SEED NOTES

By C. O. SKINROOD

Demand for the late grown seeds such as soy beans and millet has been fair according to Milwaukee handlers. Much of this demand is yet unfilled as the buying season will extend for several weeks more. Soy beans bid fair to be popular this year with the boosting of this class of seeds by the College of Agriculture at Madison.

Dealers in Milwaukee report that the principal demand for seeds this season has been almost entirely concentrated on the Red Clover and on the Alsike seeds. These were down in price the most as compared with last year and this caused the principal buying to be concentrated there.

The Alfalfa seed demand in the state of Wisconsin this year was not as large as expected according to the Milwaukee handlers, who say that because of the low prices of Red Clover and of Alsike, the demand which usually appears for Alfalfa was absent. Alfalfa growing campaigns were conducted in the past winter and spring in many Wisconsin counties but they did not seem to have much effect in stimulating demand for the Alfalfa seed.

The most striking change in the seed market for the past month was the advance in the Timothy market. The demand for this seed had not been especially good at Milwaukee and there was no sign of any great call for it. But all at once the price

climbed about \$2 per hundredweight, to \$8, having been selling previously around \$6 or less for the ordinary grades. Milwaukee seed handlers stated that there was more of a depletion of the supply of Timothy seed over the last few months and the supplies were actually much less in the market than had been estimated. Hence, it took only a comparatively small amount of buying to force the price up. Even at that, the rise in Timothy seed came as a considerable surprise.

The May prices at Milwaukee on the leading seeds are holding steady with the exception of the rise in Timothy seed. The Timothy range has been mostly from \$8 to \$9. The Red Clover has been selling largely around \$22 for the choice class of seeds. Alsike has been quoted at approximately \$21 or a shade higher. Sweet Clover has held steady around \$8 to \$9, which is the usual price level. Alfalfa ranges from \$23 to \$27 with the choice northern grown seed a little higher than the range named. White Clover seed is mostly nominal.

An excellent demand for Sweet Clover seed was reported by Milwaukee handlers for the past season. The price of seed has not varied much, the seedsmen say, and hence there is a steady demand in this class of seeds year after year which goes on regardless of fluctuating prices in other lines of seeds. Due to the promotion of Sweet Clover planting by the University of Wisconsin College of Agriculture there are thousands of Wisconsin farmers who want a certain acreage in Sweet Clover at all times so that there will be plenty of feed for summer pasturage when the regular pastures are low in grass.

The demand for seed corn for the season at Milwaukee was only fair. Predictions had been made there would be a decisive scarcity in this field. But the demand proved to be only ordinary. One factor in the market was the comparatively large amount of seed corn in the state carried over from a year ago. Another factor was apparently the idea that many farmers are now making sure of their own seed corn by careful picking and curing so that they will not have to go into the market and buy corn for seed. At any rate the demand slumped off and there was no sign of concerted buying. Seed corn is being quoted around \$1.85 to \$3.25 in the Milwaukee market.

Prof. R. A. Moore, the seed specialist of the Wisconsin College of Agriculture estimates that the total sales of Wisconsin pure bred seeds will be around \$3,000,000 for the 1929-1930 season. The sales of seed corn by the various raisers of the experimental association are estimated around \$1,000,000. He also believes that the sales of barley will be found heavy this year with a demand for some 20,000 bushels of the new smooth-awned barley which is just growing popular and about 200,000 bushels of the standard pedigreed barley which has been distributed for many years. Prof. Moore also estimates that the sales of seed oats for the past season totaled many thousands of bushels.

Great interest is being taken in the state in Smith Hughes 100-bushel corn club which is being sponsored by the Wisconsin Experiment Station. The requirement of the members of the club is that members must be able to raise 100 bushels of shelled corn to the acre. Boys entering the contest must buy some seed corn which is Wisconsin pure bred to be eligible to membership. Although this yield of 100 bushels of seed corn seems high according to the experts of the Wisconsin College of Agriculture it is not impossible to get such yields.

INDIANA SEED NEWS

By W. B. CARLETON

Both wholesale and retail seed dealers in towns and cities in Indiana report trade greatly improved over a month ago. The fact is trade in most sections during the spring season has shown a great improvement over the corresponding period of last year. Corn planting in the southern and central parts of the state was started in April, but in many instances planting was delayed greatly by the fact that the ground was too dry to work.

Lack of rainfall prevented the farmers getting their corn in. Weather reports show that April was one of the driest months for many years back and the amount of rainfall was considerably under

normal. The acreage of corn however, is expected to be about the same in Indiana this year as in former years. As stated in previous letters to the AMERICAN ELEVATOR AND GRAIN TRADE, a great problem with the Indiana farmers this year has been to get good seed corn. Many county agents, together with farm bureau officials have co-operated with the farmers in getting good seed corn. The dry weather in central and southern Indiana during the month of April is said to have damaged the growing wheat crop to a certain extent. Many wheat fields look "ragged" and in some instances wheat fields have been plowed under by the farmers and planted in corn and cowpeas.

A wheat development project in eight counties in southern Indiana to cover a period of five years, which has been worked out between Purdue University at Lafayette, and milling concerns, in hopes of developing varieties of wheat that will produce more to the acre, retain the hardness of the hard varieties, and still have the milling qualities of Soft wheat was presented for discussion between prominent wheat growers and county agents held at Evansville the last week in April. The development project has been made possible by southern Indiana millers who have financed a fellowship in Purdue University to be known as the Southern Indiana Millers' fellowship in crop improvement, according to John L. Igleheart, Purdue university has given its co-operation to the proposed plan and has agreed to supervise the laboratory work.

Soy beans have a regular place on the program of the Indiana farmer and should not be considered as a competitor of other legumes such as Red Clover, Mammoth Clover, Alfalfa and cow peas. K. E. Beeson, of the soil and crop department of Purdue University, told Posey County farmers at Mt. Vernon in an address recently. Three-fourths of the soy bean acreage is cut for hay each year in Indiana and despite the fact that the acreage is increasing rapidly, the proportion cut for hay remains about the same, Beeson stated. Soy beans are valuable, he said, to furnish protein for feeds.

Meadows in central and southern Indiana are looking fairly good just now, although a good soaking rain would greatly benefit them, according to recent reports. The meadows came through the past winter in fairly good shape. It is believed that the yield of Timothy in the state will be as good as that of last year. Indiana farmers are turning more and more to the raising of Alfalfa and the acreage will be increased this year, reports indicate.

SUNFLOWER SEED STOCKS UNUSUALLY LARGE

Sunflower seed stocks of dealers who make a specialty of this seed are estimated this spring at approximately 12,000,000 pounds by the United States Bureau of Agricultural Economics. This quantity does not include, except in a few cases, stocks held by poultry feed manufacturers, which presumably will be consumed almost entirely in their feeds before new-crop seed is available. Inasmuch as poultry feed manufacturers make the bulk of their sunflower seed purchases in November, October and December, in that order, and usually buy but little during April to August, inclusive, relatively small quantities of this seed would normally be purchased by them during the next four or five months. The carryover of sunflower seed into the new-crop year is expected to approximate the normal annual requirements (10,600,000 pounds) of 120 of these manufacturers. It suggests the feasibility of greatly curtailing the acreage to be planted this year.

Ninety-five poultry feed manufacturers, replying to a special inquiry, dated March 27, regarding sunflower seed stocks and requirements indicated that their present stocks were about 15 per cent larger than usual and that they intended to use only about 5 per cent more sunflower seed than usual in their feeds. The majority (54), however, indicated that their stocks were normal, 26 reported that they were above normal, and 15 that they were below normal.

Apparently low prices for sunflower seed will not have so much effect upon the proportion used in poultry feeds as one might suppose, judging from the reports of poultry feed manufacturers. Of the 16 manufacturers who expected to use more sun-

(Continued on Page 692)



ELEVATOR AND GRAIN NEWS

EASTERN

The Department of Public Works plans to build a 1,000,000-bushel grain elevator adjoining the New Haven railroad yards in South Boston, Mass.

The Berkshire Farmers Exchange, Inc., Pittsfield, Mass., has been incorporated with a capital of \$100,000. Edgar A. French of Boston, is president.

Officials of the New York Central and the Delaware & Hudson railroads are studying the feasibility of building grain elevators at Albany, N. Y., to forestall the diversion of grain traffic to Canada following the opening of the Welland Canal.

OHIO AND MICHIGAN

W. A. Linkhart has equipped his elevator at Sabina, Ohio, with new elevating equipment.

The Sherwood (Ohio) Elevator Company has improved its elevator equipment with a corn cutter, grader, corn sheller, and a feed grinder.

The Fostoria (Ohio) Milling & Grain Company will increase the storage capacity of its plant to 600,000 bushels this spring. The new unit will consist of 10 large concrete storage tanks.

A Fairbanks Ball-bearing Motor has been installed in the elevator of the Evert Milling Company at Sears, Mich. Starters with automatic low voltage and overload time limit relay protection control the motor.

The National Milling Company has let contract to the McDonald Engineering Company, Chicago, for the construction of its new 2,250,000-bushel storage unit which it will build at Toledo, as reported in a former issue.

The Hagan Grain Company, Bennington, Mich., is building a warehouse addition to its elevator and installing a 10-horsepower motor to replace its engine power. The motor will be enclosed in a fire-resistive enclosure.

The Cleveland (Ohio) Grain Company announces that it will rebuild its elevators, which burned recently, and will handle about 10,000,000 bushels of grain yearly. A site in Cleveland or one of its suburbs will be selected.

Robert G. Palmer, who has been operating at Belding, Mich., under his own name and as the Belding Grain & Produce Company, has leased his elevator to C. H. Runciman, of Lowell, Mich., and has sold his business to the King Milling Company, of that place.

WESTERN

The Burns (Mont.) Grain Company has closed its plant.

Plans are being promoted for establishing a co-operative elevator at Fort Benton, Mont.

The Big Horn Marketing Association plans to build a bean cleaning plant at Powell, Wyo.

The Northwest Grain Association plans to open offices at Great Falls, Mont. John McVay is manager.

The Davenport (Wash.) Mill & Elevator Company, which has been closed for two years, is now in operation.

The Winter-Truesdell-Diercks Company, Minneapolis, Minn., has closed its elevator at Opheim, Mont., until the movement of the new crop.

The Chamber of Commerce, Spokane, Wash., announces that additional grain storage of 1,000,000 bushels is practically assured for that city this fall.

The Dock Commission of Portland, Ore., has announced plans for a 1,000,000-bushel grain storage addition to the public elevator. The new unit will be completed sometime in September.

The Ritzville (Wash.) Elevator Company has covered its house with corrugated sheet iron, and has made other improvements, consisting of a concrete platform, a wheat pit, and a hopper scale.

The elevator at Cody, Wyo., formerly owned by J. R. Olson, has been taken over by a group of farmers. The company has been incorporated for \$20,000. O. E. Knight is president, and E. E. Newton, manager.

The Washington Co-operative Egg & Poultry Association, Spokane, Wash., is building a two-story warehouse and grain elevator. Cost of building and machinery is estimated at \$50,000. The new building will adjoin the present warehouse and

mill. The elevator will have a capacity of about 45,000 bushels. Meyers & Telander have the contract. James F. Thomas is manager of the association.

The Stockett (Mont.) Grain Company has been incorporated with a capital of \$20,000 to buy and sell grain and operate elevators. Incorporators are Vernon Van Koten, Wolfgang Raunig, John Yuhas, and Stephen Mayernik, of Stockett; and John Pettapiece of Eden.

The Wendell (Idaho) Elevator Company is now occupying its new warehouse and office building, which has been equipped with new machinery. Construction will start soon on a new elevator, to replace the one which burned early in the year. It will be completed in time for the new crop.

IOWA

F. D. Mohnike has protected his elevator at Wever with lightning rods.

The Dinsdale (Iowa) Grain & Lumber Company has protected its plant against lightning.

G. R. Spurgeon, who has bought the Adams elevator at Galva, will take possession July 1.

The Farmers Elevator Company at Slifer has changed its power from gasoline to electric.

Sufficient stock has been sold to assure the erection of a new elevator at Kiron, it is reported.

R. A. Reese, of Des Moines, and H. L. Moorehead have organized a grain business at West Branch.

The T. B. Hord elevator at Genoa (Seymour, p.o.) has been closed until the movement of the new crop.

Plans are being promoted for the organization of a co-operative elevator and feed store at Williamsburg.

The Corwith (Iowa) Co-operative Grain Company and the Farmers Grain Company have recently merged.

The Farmers Elevator Company, Hobarton (Algonia p.o.), is repairing its elevator and putting in a new foundation.

Two large gasoline tanks and a gasoline truck have been added to the equipment of the Modale (Iowa) Elevator Company.

The Howard County Equity Association has bought the Hunting elevator at Elma which it will move to its present site.

The Farmers Elevator Company is operating its new elevator at Morrison which replaces the one destroyed by fire in January.

George Livermore, after operating a grain business at Swea City for 25 years, has closed both his elevators because of ill health.

The North Iowa Grain Company has taken over the business of Davis Bros. & Potter who operated the Dunkelbarger elevator at Nevada, Iowa.

The L. W. Hess elevator at Traer has been sold to the Farmers Elevator Company for a consideration of \$3,250. Mr. Hess has moved to Center Point.

The Chamber of Commerce announces that a new elevator is to be built at Burlington. C. A. Johnson, grain dealer at Oakville, is seeking a site in the North Bottoms.

MINNESOTA AND WISCONSIN

The Atlas Elevator Company, Marshall, Minn., has installed a 10-ton coal scale.

It is rumored that the Milwaukee railroad may build a large grain elevator at Milwaukee, Wis.

The elevator of the Eagle Roller Mill Company, Porter, Minn., has been repaired and equipped with a new boot tank.

The Edmonds-Londergan Company has improved its elevator at Steen, Minn., with new boot legs, head distributor, electric motor drive, and cups.

The Pioneer Land & Loan Company will build an addition to its elevator at Warren, Minn., using lumber from the old mill which it is wrecking.

The Farmers Elevator & Supply Company is spending \$4,000 in improvements on its elevator at Canby, Minn. A new feed grinder will be added to the equipment.

The Farmers Union Terminal Association will begin construction shortly of a 1,000,000-bushel grain elevator at Minneapolis, Minn. The company also

plans to double the capacity of its elevator in St. Paul by the erection of a 1,000,000-bushel addition, as previously reported.

The Kiel (Wis.) Community Mercantile Company has recently been re-organized to deal in grain, feed, and flour. Incorporators are H. Wessel, G. Mattes, and L. Spindler.

Because of the small acreage of wheat grown in that section, the Vergas (Minn.) Northland Grain Elevator has closed its house which has been operating for 26 years.

The Froedtert Grain & Malting Company is considering the addition of 19 storage tanks to its elevator at Milwaukee, Wis. The new units would have a capacity of 1,000,000 bushels.

The Harland Flour & Feed Company has reopened the elevator of the Cargill Commission Company at Waseca, Minn. The plant is being remodeled and equipped with new machinery. Ray Roesler is in charge.

The Mullin & Dillon Company has been recently organized to operate a general grain business at Minneapolis, Minn. The firm is composed of W. E. Mullin and L. J. Dillon. They will have offices at 914 Flour Exchange.

THE DAKOTAS

A farmers co-operative elevator company is being organized at Bowdon, N. D.

The farmers of Mellette County plan to build a \$30,000 elevator at Wood, S. D.

John Henning has protected his elevator at Lake Andes, S. D., with lightning rods.

Robert Yaggee has equipped his elevator at Yankton, S. D., with lightning rods.

The Flandreau (S. D.) Grain Company is installing a 15-ton scale in its elevator.

The Powers Elevator Company has closed its house at Hebron, N. D., for the season.

The Farmers Elevator Company is covering its house at Badger, S. D., with galvanized iron.

Von Seggern Bros. have protected their West elevator at Gregory, S. D. against lightning.

The Wells Grain Company, Edgeley, N. D., will rebuild its elevator which burned recently.

Lightning rods have been placed on the elevator of the Farmers Grain Company at Bonesteel, S. D.

The Farmers Elevator Company is repairing its house and rebuilding its coal plant at Colton, S. D.

The Sexauer Elevator Company plans to install additional electrical equipment in its elevators at Onida, S. D.

C. C. Wyman & Co., grain merchants at Minneapolis, Minn., has purchased the business of the W. C. Mitchell Company at Minot, N. D.

The Farmers Equity Union, Rhame, N. D., has let contract for construction of a new elevator to replace the one which burned last winter.

The Shannard Elevator Company, of Bridgewater, is operating the elevator of the Hirsch Grain Company, Tripp, S. D., which it recently bought.

The lumber from the old Spencer (S. D.) mill, which is being torn down, will be used in rebuilding the elevator of the Hoese-Lueth Grain Company.

The Zarba Land & Elevator Company has protected both its elevators at Herrick, S. D., with lightning rods, and has placed a metal roof on one of them.

The 35,000-bushel grain elevator, at Wilmot, S. D., formerly operated by the Getchell-Tanton Company, has been taken over by Norbert Lang of Benson, Minn.

The Farmers Exchange at Lowry, S. D., plans to operate its two elevators as one unit and is having them moved together. Contract has been let for new foundations.

Contract for the 85,000-bushel elevator which the Tri-State Milling Company will build at Belle Fourche, S. D., as previously reported, has been awarded to the Hickok Construction Company. The elevator will be of reinforced concrete construction and will be equipped with modern machinery.

A new 60,000-bushel modern grain elevator will replace the plant of the Farmers Co-operative Elevator Company at Simcoe, N. D. The old house is being wrecked. The Hogenson Construction Com-

pany has the contract for the new elevator which will be equipped with modern grain handling and cleaning equipment, a three-room office, fireproof vaults, and other improvements.

Peter Erickson, of Miles City, Mont., will start construction shortly of a \$15,000 grain elevator at Kadoka, S. D. Mr. Erickson recently sold his elevator at Miles City.

The Farmers Union Terminal Association of St. Paul, Minn., plans to build elevators of 500,000 bushels capacity at Williston, Minot and Fargo, N. D., and Fairmont, Minn. M. W. Thatcher is general manager.

The Alamo (N. D.) Farmers Co-operative Elevator Company has improved its elevator with new roller bearings and a 10-ton dump scale. All of the machinery will be re-set and the whole plant overhauled.

The Clear Lake (S. D.) Farmers Elevator Company has let contract to the T. E. Ibberson Company for the construction of a new 32,000-bushel elevator to replace the one which burned in March. The elevator will be iron-clad and equipped with motor power, scales, and other improvements.

INDIANA

The Farmers Federation, of Rockville, has an option on the Reichard Bros.' mill.

The Farmers Elevator Company at Monticello is considering the feasibility of putting its elevator on a co-operative basis.

Earl Walker has taken over his father's interest in the elevators of J. M. Walker & Son, which has operated at Middletown for several years.

Ed Teagarden, owner of the elevator at Saratoga, which burned, is moving his elevator at Deerfield to Saratoga. The elevator at Deerfield is now being dismantled.

The Farmers Grain Company, of Carlos, has filed reorganization papers under the name of Farmers Grain Company, Inc., to buy and sell grain and cereal products. Directors are H. T. Frazier, Otto Gordon, A. C. Engle, R. G. Miller, Harry Miller, U. G. Retter, and Clyde L. Catey.

Directors of the Berne (Ind.) Grain & Hay Company announce that they will rebuild their elevator which burned a few days ago. New grinding and mixing equipment will be installed in the new house. The company is still conducting its feed and coal business as the warehouse and coal bins escaped damage.

The Farmers Co-operative Company of Indiana, with headquarters at Indianapolis, is purchasing several elevators, including the properties of Crabbs-Reynolds-Taylor at Crawfordsville, Cherry Grove, Linden, Wingate, Lafayette, South Raub, Taylor Station, Crane, West Point, Riverside, Battle Ground, Ash Grove, Smithson, Reynolds, and Francesville.

SOUTHERN AND SOUTHWESTERN

The Spearman (Texas) Equity Exchange is contemplating the building of an additional grain storage unit.

The Perryton (Texas) Equity Exchange plans to build a grain elevator of 200,000 or 300,000 bushels' capacity.

The McConnell Grain Company, Kings Mill, Texas, is building a grain elevator which will be completed in July.

The Harvest Queen Mill & Elevator Company, Plainview, Texas, has increased its capital from \$250,000 to \$600,000.

The Texas Wheat Growers Association has contracted to build a 25,000-bushel grain elevator at Hale Center, Texas.

Lightning rods have been placed on the elevator of the Farmers Union Company Co-operative Exchange at Red Rock, Okla.

Included in the Oklahoma-Texas Wheat Growers' expansion program is a 25,000-bushel elevator which will be built shortly at Dimmitt, Texas.

The Farmers Co-operative Elevator Company, Buffalo, Okla., may lease its elevator to the Oklahoma Wheat Pool Elevator Corporation.

Fifteen elevators are to be built in the vicinity of Dalhart and Morse, Texas, according to T. H. Wilhelm, general freight agent of the Rock Island railroad.

The Oklahoma City (Okla.) Mill & Elevator Company will rebuild shortly its elevator which burned on April 9. New grain handling machinery will be installed.

The Roberts Construction Company, Sabetha, Kan., has contract for the construction of a 25,000-bushel elevator at Vega, Texas, for the Texas Wheat Growers Association.

The Oklahoma Wheat Pool Elevator Corporation has taken over the elevators of A. H. Clausing at Covington and at Lucien, Okla. The transfer will be completed June 1. Mr. Clausing will continue

as manager of both houses and will also continue to conduct his feed business at both places. The Pool plans to acquire 140 rural elevators. John Manley, Enid, Okla., is general manager.

The Feeders Mill & Elevator Company, Fort Worth, Texas, has recently been incorporated with a capital of \$7,500. Incorporators are H. B. Mobley, W. V. Garrett, and A. B. Garrett.

The Lemons-Thompson Grain Company has been incorporated with a capital of \$70,000 to operate at Amarillo, Texas. Incorporators are M. W. Lemons, J. D. Thompson, and W. N. Thompson.

The McLean & Pittman Grain Company has taken over the E. W. Harrison Elevator Company's business at Hereford, Texas, which was conducted by E. W. Harrison who died some time ago.

The Milam Grain & Milling Company, New Orleans, La., is making alterations and building an addition to its plant. J. M. Werling, 2909 St. Bernard Avenue, is receiving bids on the work.

The 500,000-bushel grain elevator which is to be built at Helena, Ark., in connection with the Government barge line service, previously announced, is to be built by the Missouri & Northern Arkansas Railroad.

T. P. Duncan and associates, Wichita Falls, Texas, have taken over the 30,000-bushel grain elevator at Ralls, Texas, formerly operated by the Alexander Grain Company. J. H. Wilson will continue as manager.

The Groom (Texas) Elevator Company is building a 25,000-bushel frame and iron-clad elevator at Boydston, Texas. The new elevator will be equipped with an eight-bushel scale, pulleys, cups, and other modern machinery.

The Channing (Texas) Elevator Company is building a 25,000-bushel frame and metal elevator at Hartley, Texas. Earl Shepherd is building the house which will be equipped with modern and fast grain handling machinery.

The Roberts Grain & Seed Company announces plans for the erection of a new 25,000-bushel elevator 10 miles west of Morse, Texas, on the Morse-Dalhart line of the Rock Island. The elevator will be completed in time for the new crop.

A \$12,000 grain elevator is being built at Canyon, Texas, by Felix Neff. The Star Engineering Company, Wichita, Kan., has the contract. Modern equipment will be installed in the plant which is scheduled to begin operations in June.

The Oklahoma Wheat Pool Elevator Corporation announces that it will build elevators of 25,000 bushels' capacity each at Abell, Adrian, and Bovina, Texas. The company plans to spend \$100,000 in the building and purchase of elevators in the Texas Panhandle.

The Farmers Co-operative Elevator Company, Enid, Okla., plans to build a grain elevator at Imo (Enid p.o.). The company has recently been incorporated with a capital stock of \$35,000. Incorporators are L. L. Lamunyon, E. W. Perry, of Enid, and F. W. Pream, of Waukomis.

The Nashville (Tenn.) Warehouse & Elevator Company is reconditioning its elevator which burned last year. The improvements will cost about \$50,000. The elevator's capacity is 500,000 bushels, and with its completion the company will have a total storage capacity of 1,100,000 bushels.

ILLINOIS

Paul R. Cushman is repairing the grain elevator at Cushman, which he recently bought.

The elevator of U. B. Memmen & Son, Minonk, has been equipped with an additional air dump.

Claude Hatch announces that he will build a new elevator at Greenview to replace the one which burned some months ago.

Bader & Co. has recently purchased the elevator of W. S. Long & Son at Rushville. Franklyn Long will continue as manager.

The Illiopolis (Ill.) Grain Company has succeeded the Illiopolis Farmers Grain Company. C. S. Scott and W. C. McGuire are owners.

The Sterling-Rock Falls Co-operative Marketing Association, which is being organized at Sterling, plans to build an elevator as soon as a site is secured.

The Winchester (Ill.) Farmers Elevator & Mercantile Company has installed new machinery in its plant. A sheller and a cleaner are included in the new outfit.

Work is progressing on the new elevator which the Schultz-Baujan Company is building at Beardstown. The new house is located on the C. B. & Q. Railroad and will be 148 feet high.

The George E. West Grain Company, Loda, has been incorporated with a capital of \$8,000. The company succeeds George E. West. Incorporators are George E., George Harold, and John Mirton West.

The Ohlman (Ill.) Grain Company, Inc., has leased the Moxley elevator at Rosewood, which it

will operate from Ohlman under the name of the Ohlman Grain Company, Inc. J. P. Leiss is manager of the company.

MISSOURI, KANSAS AND NEBRASKA

W. N. Miller has improved his elevator at Yutan, Neb., with a truck dump.

The C. S. Laird elevator at Ingalls, Kan., has been sold to the Ingalls Co-operative Exchange.

The R. & A. Grain Company has protected its plant at Ransom, Kan., with lightning rods.

Harrington & Cummings have equipped their elevator at Lillis, Kan., with lightning protection.

Lloyd O. Ruyle announces that he will rebuild his elevator which burned recently at Armour, Neb.

The Citizens Grain Company is building a 22,000-bushel grain elevator five miles east of Moscow, Kan.

Lightning rods have been placed on the plant of the Brenham (Greensburg p.o., Kan.) Mercantile Company.

Electric motors and a head drive have been installed in the plant of the Western (Neb.) Elevator Association.

The Citizens Grain Company is operating the elevator at Deshler, Neb., formerly operated by the Hebron Grain Company.

An electric motor and a head drive have been added to the equipment of the Farmers Elevator Company at Lindsay, Neb.

The Farmers Union Co-operative Association is installing an overhead traveling electric truck dump in its plant at Otoe, Neb.

The Clark, Rocklage & Fowler Grain & Produce Company, Richmond, Mo., is occupying its new building, recently completed.

The Lexington Mill & Elevator Company has leased the Gothemburg (Neb.) Mills which it will conduct as one of its elevator branches.

The Gering (Neb.) Mill & Elevator Company plans to reorganize as a co-operative unit and affiliate with the Farmers National Grain Corporation.

The Osborne County Farmers' Union Co-operative Association, Portis, Kan., is building an elevator which is to be completed in time for the new crop.

The Nebraska Consolidated Milling Company has let contracts for the erection of four large grain storage tanks adjoining its plant at Grand Island, Neb.

The Lowry Grain Company and the Warren Grain Company have repaired their plants at Sanford, Kan. They will, hereafter, operate under one management.

The Grain Belt Elevators, Wright, Kan., have sold their 37,000-bushel house to the Wright Co-operative Company which now has a total storage capacity of 50,000 bushels.

Ryan & Flynn, Omaha, Neb., are contractors for the new 180,000-bushel elevator which the Fowler (Kan.) Equity Exchange will build, as previously reported.

Chalmers & Borton has supervision of construction of the 550,000-bushel grain elevator which the Jennings Grain Company will build at Hutchinson, Kan., as previously reported.

The Hall-Baker Grain Company will operate the Murray elevator in Kansas City, Mo., this year. The company will then have a total storage capacity in Kansas City of 5,500,000 bushels.

George E. Gano has completed arrangements for erecting an elevator at Tennis Station, between Garden City and Scott City, Kan. The structure will be completed in time to receive the new crop.

The Missouri Pacific Railroad has let contract to E. Ahlskog Company, 409 S. Dearborn Street, Chicago, for construction of a 2,076,000-bushel addition to its elevator at St. Louis, Mo. Estimated cost is \$700,000.

Contract for the 50,000-bushel grain elevator which the Clyde Co-operative Association plans to build at Medford, Okla., as previously reported, has been let to the A. F. Roberts Construction Company, of Sabetha, Kan.

The Industrial Engineering Company was the lowest bidder for construction of the new elevator which the Co-operative Equity Exchange will build at Cimarron, Kan., as previously reported. Estimated cost is \$45,000.

The Co-operative Elevator & Supply Company, Meade, Kan., has let contract to Chalmers & Borton, Kansas City, Mo., for construction of its new 125,000-bushel grain elevator, previously reported. Estimated cost is \$45,000.

Contract has been let to the Industrial Engineering Company for the construction of a grain elevator at Dighton, Kan., for the Farmers Co-operative Elevator & Mercantile Association. Cost is estimated at about \$50,000.

The Wallingford Grain Company announces that it will add storage units of 375,000 bushels capacity

to the Public Terminal Elevator at Wichita, Kan. Contract for construction has been let, and the new addition is to be completed in time for the 1930 crop. With the new units, the company will have a total storage capacity of approximately 750,000 bushels.

The Minneola (Kan.) Co-operative Exchange has let contract to the Burrell Engineering & Construction Company for the building of its 150,000-bushel elevator, announcement of which has been previously made. Estimated cost of the new project is \$50,000.

The Hamilton County Grain Corporation has been organized at Syracuse, Kan., and is building a modern 30,000-bushel iron-clad elevator which will be completed in time for the new crop. The elevator will have a daily loading capacity of 20 cars of grain.

The Butler-Welsh Grain Company, Nebraska City, Neb., announces plans for enlarging its elevator from 340,000 bushels to 1,250,000 bushels. J. B. Berger, manager, says that contract will be considered soon and that the improvement will take place within the year.

The Rodney Milling Company, Kansas City, Mo., has let contract for the construction of a 250,000-bushel storage addition to its plant. The new unit will consist of eight concrete tanks which will be completed in time for the new crop. The new addition will bring the company's total storage capacity up to 550,000 bushels.

CANADA

The Canadian Terminals System, Ltd., plans to build a 2,500,000-bushel elevator on Catarqui Bay, Kingston, Ont. H. I. Price is vice-president and general manager. The Canada Steamship Lines, Ltd., is now building an elevator at this point, as previously reported.

The 5,500,000-bushel grain elevator which the government is building at Prescott, Ont., is to be completed by August 1, according to report from assistant trade commissioner at Ottawa. The legs unloading from the upper lake boats will have an hourly capacity of 35,000 bushels, according to the specifications.

Bids were received up to May 13 by the Department of Railways and Canals for the construction of a 2,500,000-bushel grain elevator at Ft. Churchill, Man. A deep water dock will also be constructed. The elevator and dock are to be completed by the fall of 1931. C. D. Howe Company is the engineering firm.

Plans are being promoted for the construction of 5,500,000 bushels' additional storage at Vancouver, B. C., part of which will be completed in time for the new crop. Elevator No. 1, leased to the James Stewart interests, is to have an additional unit of 2,000,000 bushels. Elevator No. 2, leased to the Alberta Pool Elevator Company, is to have a 1,000,000-bushel addition; and Elevator No. 3, leased to the United Grain Growers, Ltd., is to have a 2,500,000-bushel unit.

Hay Straw and Feed

S. A. Jerdee plans to build a feed grinding outfit at Arkdale, Wis.

H. A. Hanschel has installed a feed grinder in his plant which is located at Cannon Falls, Minn.

Charles Rummey has taken over the feed business of H. Marcus at Muscoda, Wis.

The Hamlet (Ind.) Grain & Feed Company has equipped its plant with a batch mixer for mixed feed manufacture.

J. S. Watts & Son have taken over the feed business of Clarkson & Sons located at Springdale, Ark.

The Farmers Elevator Company, Grundy Center, Iowa, has installed a new grinding machine in its feed department.

The Weart & Lysaght Company, Cherokee, Iowa, has added an oats huller to its feed equipment.

The Taintor (Iowa) Co-operative Elevator Company has added to its equipment a new feed mixer.

A pneumatic system for handling meal has been installed in the elevator of Oscar Berga at Amboy, Ill.

A 50-horsepower feed grinder has been installed in the plant of Albert M. Bohnert & Son at Jasper, Ind.

A new feed grinder has been added to the plant equipment of A. M. Bohnert & Son at Evansville, Ind.

The Monarch Elevator Company announces that a feed grinding mill may be opened at Halstad, Minn.

The Farmers Elevator Company, of Ruthton, Minn., is operating its new feed plant, recently installed.

The Rapier Sugar Feed Company, Evansville, Ind., is building a frame warehouse and store building.

John M. Lindbloom, Frank Whitehead, and Samuel Dunlap have opened the Pioneer Feed & Seed Company at Mt. Vernon, Wash. Mr. Lindbloom conducted a feed business at Mt. Vernon some time ago.

The International Sugar Feed Company, of Minneapolis, Minn., has established a branch at Florence, Neb.

Chris and E. J. Mosher, of Goshen, have installed and are operating a feed grinding outfit at Westville, Ind.

A 30-horsepower feed grinder has been installed in the plant of the Farmers Elevator Company at Richmond, Mich.

New feed grinding equipment has been installed in the feed plant of A. W. Pulley & Sons at American Fork, Utah.

The Conroy (Iowa) Lumber & Grain Company has installed a new feed grinder and oats huller in its new addition, recently completed.

The Sioux City (Iowa) Feed Company has been incorporated with a capital of \$25,000. Incorpo-

rators are E. McHahn, A. B. Scollard, and G. E. Rhodes.

The elevator of A. Tosch & Son, Capac, Mich., which was recently taken over by the Almont (Mich.) Elevator Company, has been equipped with a 30-horsepower feed grinder with magnetic separator attached.

Carl C. and John S. Coulson, former owners of the Napavine (Wash.) Feed Company, plan to establish a feed business at Klamath Falls, Ore.

Jack Maki has sold his feed, hay, and flour business at Ely, Minn., to the Merchants Warehouse Company of Hibbing, which is conducted by M. Salminen & Sons.

The Rapier Sugar Feed Company, Owensboro, Ky., manufacturers of sweet feeds, has completed a new warehouse at the junction of Dixie Bee and Boonville highways.

The Archbold (Ohio) Seed & Feed Store, Inc., has been chartered to deal in seeds and grain and also to grind grain. Incorporators are Eli Luginbill, Sylvanus Luginbill, and Ivan W. Werder.

The Dakota Feed & Seed Company, Watertown, has purchased the Garrick Grain, Feed & Fuel Company of Webster, S. D., which it will operate as a branch. A. A. and J. C. Garrick will be in charge.

The Merchants Warehouse Company, Hibbing and Chisholm, Minn., is installing feed grinding and feed mixing machinery in the plant of the Eveleth (Minn.) Flour & Feed Company which it recently bought.

OBITUARY

ARMSTRONG.—Frederick P. Armstrong, president of the Whitney-Noyes Seed Company, Buffalo, N. Y., died April 20 at the age of 59 years. Mr. Armstrong had been an official of the company for 25 years. His widow and four children survive him.

BOSWORTH.—M. E. Bosworth, auditor of the Monarch Elevator Company, Moorhead, Minn., died in Fargo, N. D., on April 5. His widow, a son, and a daughter survive him.

BROWN.—J. Crosby Brown, veteran member of the Commercial Exchange at Philadelphia, Pa., died suddenly on April 1.

CROWE.—Patrick Crowe, president of the Ady & Crowe Mercantile Company, feed manufacturers at Denver, died April 23, following an illness of three months. Three children and three nephews survive him.

DOUGLASS.—T. J. Douglass, pioneer grain dealer of Los Angeles, Calif., died at Birmingham, Ala. He was 78 years old. Mr. Douglass was one of the organizers of the McDonald Grain & Milling Company. Two sons and a daughter survive him.

EDWARDS.—Robert L. Edwards, a Government grain elevator and warehouse inspector since 1926, died recently as the result of a fall in an elevator shaft in Kankakee, Ill. He was 32 years old.

EISNER.—David I. Eisner, veteran member of the Produce Exchange, New York, and retired grain dealer, died April 17 of injuries received in an automobile accident. He was 81 years old. His widow and two sons survive him.

FRITZE.—George Fritze, 92, former member of the Chicago Board of Trade and founder of Leet & Fritze, a brokerage firm now extinct, died.

GREER.—Thomas B. Greer, member of the grain firm of Gardner & Greer, Memphis, Tenn., died recently following an illness of several months. He was 63 years old. His widow and two children survive him.

HOBENSACK.—William Hobensack, member of the Philadelphia Commercial Exchange for 35 years, and dealer in grain, millfeed, and flour, died April 11 at his home in Ivyland, Pa.

HORTON.—William H. Horton, retired grain and feed dealer of Memphis, Tenn., died April 14, at the age of 82 years. His son, J. B. Horton, is with J. B. Horton & Co., grain dealers, at St. Louis, Mo.

KERCHEN.—Nicholas S. Kerschen, grain dealer at Marysville, Kan., died late in March at the age of 61 years. Mr. Kerschen had been manager of the Farmers Elevator Company, of the Marysville Mill, and later established his own business. Two sons survive him.

LEAMAN.—C. H. Leaman, manager of the Saskatchewan & Western Grain Company, and member of the Winnipeg Grain Exchange, died recently while driving in his automobile. He was 62 years old. His widow and a daughter survive him.

MALONEY.—The death of John J. Maloney was erroneously reported in a former issue instead of

the death of Mrs. John J. Maloney. Mr. Maloney is a grain broker in Winnipeg, Man.

McQUEEN.—Hugh Randolph McQueen, retired grain broker, died April 19 at his home at Passaic, N. J. He was 71 years old.

MEANS.—O. L. Means, who operated elevators for several years in London, Fairland, and Brookfield, died May 6 at his home in Action, Ind. His widow and a brother survive him.

MILES.—William S. Miles, secretary of P. B. & C. C. Miles, Peoria, Ill., died April 17 of double pneumonia. His widow and one son survive him. (See further details elsewhere in this issue.)

MURPHY.—Walter H. Murphy, member of the Chicago Board of Trade, died April 14 at Park Ridge, Ill. He was 60 years old. A daughter and two sons survive him.

NEWTON.—Stanley E. Newton, of the Sennott Grain Company, and member of the Boston Grain & Flour Exchange, died recently of monoxide poisoning. He was buried from his residence in Lynn. (See further details elsewhere in this issue.)

PACKER.—George H. Packer, member of the Produce Exchange, New York, and connected with the traffic department of the Lehigh Valley Railroad, died recently at his home in Bound Brook, N. J.

ROCKWELL.—Captain Bertrand Rockwell, formerly a grain dealer in Junction City, Kan., died April 15 at his home in Kansas City, Mo. He was 86 years old. Captain Rockwell started in the grain business in 1865, and retired several years ago.

RUEGEMER.—R. J. Ruegemer, agent for the Cargill Elevator Company at Richmond, Minn., died a few weeks ago. His widow and an infant son survive him.

RYAN.—Michael J. Ryan, member of the Chicago Board of Trade, died a few weeks ago.

SOWERBY.—George F. Sowerby, who operated elevators for several years in Buffalo, N. Y., died April 25 at the age of 79 years. His widow and a daughter survive him.

THOMSON.—James W. Thomson, member of the Chicago Board of Trade since 1898, died at his home in Chicago on April 19. Mr. Thomson was associated with the Rosenbaum Grain Company for 30 years. He was 70 years old.

WALLER.—Aaron Waller, grain dealer at Henderson, Ky., died recently of pneumonia. He was 68 years old.

WELLER.—Felix J. Weller, former president of the Weller Manufacturing Company, Chicago, Ill., died May 10 at Riverside, Calif. (See further details elsewhere in this issue.)

WIEMER.—John Wiemer, of the Wiemer Grain Company at Allen (San Jose p.o.) Ill., died recently.

WILEY.—M. O. Wiley, manager of the linseed meal sales department of the Fredonia (Kan.) Linseed Meal Company, died recently.

FIRES—CASUALTIES

Lamont, Alta.—Fire recently destroyed the Brooks elevator.

Dana, Iowa.—Fire recently destroyed the C. C. Buck grain elevator.

Paris, Ky.—Warehouse M of Brent & Co., Inc., was destroyed by fire on April 28.

Hay Springs, Neb.—The Merchant elevator was damaged considerably in a recent fire.

Hollis, Kan.—Fire destroyed the elevator of the Campbell Grain Company on April 11.

Decker, Man.—Fire destroyed the elevator of the N. Bawlf Grain Company of Winnipeg.

Bernice, Okla.—The Lindsay elevator and mill burned on April 22 causing a loss of \$10,000.

Onida, S. D.—Fire severely damaged the north elevator of George P. Sexauer & Son on May 3.

Watson, Mo.—Fire destroyed the elevator of O. H. Bayless on April 22, causing a loss of about \$4,000.

Frantz (Geneseo p.o.), Kan.—A severe wind completely wrecked the elevator of W. C. Groth on May 6.

Terrell, Texas.—A feed warehouse of Matthews & Austin Grain Company burned, causing a loss of \$1,000.

Bixby, Minn.—The R. E. Jones & Company's elevator, containing 9,000 bushels of grain, burned on April 7.

Vining, Minn.—The Farmers Elevator Company's house, containing 7,000 bushels of grain, burned recently.

Bee, Neb.—Fire destroyed Rudolph Strunc's feed and seed house, and other buildings, causing a loss of \$9,000.

Kary (Elgin p. o.) N. D.—The elevator of M. J. Cullen, of Bismarck, burned early in April, causing a loss of \$6,000.

Hitchcock, S. D.—The elevator of the Atlas Elevator Company, Minneapolis, and 10,000 bushels of grain burned recently.

St. Boniface, Man.—Explosion and fire damaged the plant of the Soubry Grain & Feed Company, causing a loss of \$12,000.

Shawnigan Lake, B. C.—McLaren's grain warehouse was destroyed in a fire which swept the business district of Shawnigan Lake.

Charlotte, Mich.—Fire damaged the plant of the L. H. Shepherd Grain, Bean & Milling Company, causing an estimated loss of \$25,000.

Southam, N. D.—Fire destroyed a few weeks ago the elevator and 15,000 bushels of grain belonging to the Woodworth Elevator Company.

Marion, Ohio.—Fire recently destroyed the grain elevator at Marion, Ohio, owned by Henry G. Dehring, of Toledo. Estimated loss is \$15,000.

Stuttgart, Ark.—The Almyra (Ark.) Elevator & Rice Mill Company sustained a loss of \$30,000 in a fire which recently burned its rice mill near Stuttgart.

Genoa, Ohio.—Grain elevators and coal yards, located near Genoa, and owned by Henry G. Dehring, of Toledo, were destroyed by fire, causing a loss of \$15,000.

Ozark, Ark.—Sossamon's seed house near his gin on Gar Creek was destroyed by fire in April. Estimated loss is \$500. The house contained seed valued at \$150.

Bigelow, Minn.—The J. J. Kramer elevator and contents, corn crib containing 400 bushels of corn, and a warehouse containing several barrels of oil, burned recently.

Oklahoma City, Okla.—One of the elevators and its contents at the plant of the Oklahoma City Mill & Elevator Company was considerably damaged by fire on April 9.

Butler, S. D.—The S. S. Anderson grain elevator burned to the ground on April 13. New feed grinding equipment and about 500 bushels of grain were included in the loss.

Fredonia, N. Y.—The plant of the Chautauqua Seed Company, and a quantity of seeds and supplies, suffered a loss of \$15,000 recently. Insurance partially covered the loss.

Minneapolis, Minn.—Fire recently destroyed two warehouses of the Northeast Feed Company. The fire, which is thought to have started from a bonfire, caused a loss of \$10,000.

Berne, Ind.—The elevator of the Berne (Ind.) Hay & Grain Company was destroyed by fire on April 16, causing a loss of around \$25,000. A carload of wheat and a quantity of other grains and

seed burned. The fire started in the electric motor starting box. Insurance partially covered the loss.

Dallas, Texas.—Benjamin Chantaca, wheat inspector for the Perry Burrus grain elevator at Dallas, Texas, was injured recently when he fell 90 feet down an elevator shaft.

Lawrence, Kan.—A dust explosion in the bakery plant of the Bowersock Mills & Power Company

FIELD SEEDS

(Continued from Page 688)

flower seed than usual, eight indicated that the increase would be 25 per cent or more above their normal requirements. Nineteen manufacturers expected to use less sunflower seed than usual, while 60 reported that they would use about the same quantity as usual.

DEALERS REPORT

Reports from large dealers in sunflower seed in the most important producing districts and from others indicate a marked decrease in the 1930 sunflower acreage in Illinois, Missouri, and California, especially in the last two States, where a reduction of 50 to 75 per cent or more is in prospect. This reduction is due to low prices for the 1929 crop and discouraging outlook for prices next fall, in the face of a large carryover.

Weather conditions during the rest of this month and next month will determine pretty largely whether the growers of sunflower seed will carry out their intentions to abandon this crop in part or entirely for other crops. In recent years production of this seed has been increasing at a faster rate than consumption, with the result that a larger surplus has occurred from year to year. Last year approximately 15,000,000 pounds was produced, or over 4,000,000 pounds in excess of the annual requirements, in the aggregate, of practically all the important poultry feed manufacturers in the United States.

SEED OPTION OFFERED TO HOOSIER POOL MEMBERS

The Central States Grain Association, Inc., a cooperative marketing association, with its principal office at Indianapolis, Ind., offers the following selling option to members signing its new marketing contract:

"The grower may retain grain for feed, and seed to be sown by himself; or feed or seed to be sold directly to other growers.

"The grower expressly warrants that he is now in a position to control said crops and has not heretofore contracted to sell, market or deliver any of his said grain to any person, firm or corporation, except as noted at the end of this contract. Any grain covered by such existing contracts or crop mortgages shall be excluded from the terms hereof for the period and to the extent that the lien-holder so legally enforces his right to possession thereof."

SEED DEMAND REPORTED GOOD

The demand for seeds continued fairly good during the forepart of May, as weather conditions were generally favorable for farm work and further progress was made in planting. Although the peak of the activity for the season had been passed for the early sown kinds, the late demand was strong for some of the grasses. Prices generally were firm or higher. Exports were of fair size but arrivals at principal ports were rather light, according to the Hay, Feed and Seed Division of the Federal Department of Agriculture.

Reviewing the situation for the month of April, the United States Bureau of Agricultural Economics points out that general seed trade showed improvement during the first week. Prices were firm, especially for the clovers most of which continued to advance during the second and third weeks. Likewise the grasses came into good seasonal call and prices advanced sharply toward the end of the month, in sharp contrast with the weakness displayed a year ago. Prices for most seeds advanced during the month but declined slightly in the case

spread to the adjoining frame elevator and caused an estimated damage of about \$2,000.

Ainsworth, Neb.—Property of E. P. Skillman, consisting of three grain houses, 4,000 bushels of oats, 200 bushels of corn, and considerable lumber, was destroyed by fire, causing a loss of several thousand dollars.

San Jose, Ill.—Fire damaged the John Weimer grain elevator at Allan Station, near San Jose, causing an estimated loss of \$20,000. The house contained no grain as it had not been in operation since Mr. Weimer's death.

Owensboro, Ky.—Fire destroyed the elevator, flour mills, and a quantity of grain of the Owensboro (Ky.) Milling Company on May 9. Estimated loss is \$100,000 covered by \$63,000 insurance. Defective wiring is thought to have caused the fire to start.

of the seed grains as the demand for them came to a close. Cool weather prevailed over most of the northern half of the United States during most of April. In the Southwest the drought was broken.

A fairly good call for Red Clover continued in parts of the East, especially in New England; but in some markets very little business was passing. Prices for domestic were unchanged. Imported, quoted at \$16.50, was up 50 cents per 100 in one market. April imports amounted to 315,700 pounds compared with 1,125,800 last year and 580,300 pounds two years ago. For the 10 months ended April 30, imports reached a total of 2,064,000 pounds, not including 323,000 pounds to be entered after staining, compared with 7,159,800 last year and 4,390,200 pounds two years ago.

Alsike Clover was in fair request. Prices averaged about 10 cents lower. April imports amounted to 1,480,800 pounds, compared with 817,900 last year and 1,312,200 two years ago.

White Clover continued rather dull. Imports for April amounted to 120,400 pounds, compared with 243,900 last year and 219,200 pounds two years ago, and for the period July 1 to April 30, they amounted to 2,078,900 pounds, compared with 2,031,200 last year and 1,301,700 pounds two years ago. Sweet clover was in diminishing call at unchanged prices.

Alfalfa demand tended to ease off further. Imports for the period July 1 to April 30 amounted to 337,000 pounds, compared with 1,145,300 last year and 766,500 pounds two years ago.

Timothy prices remained firm as a strong demand continued in some markets. During week about 43,200 pounds left one Atlantic port for Great Britain. Redtop demand continued strong. Prices made an average advance of 45 cents. During the week about 7,700 pounds left one Atlantic port for Germany.

Soy beans were fairly active in some markets but cowpeas were rather slow although slight improvement was shown. Stocks are of fair size. Seed corn demand continued strong, especially for the late varieties, as planting progressed under favorable weather conditions. In some of the northern localities planting started earlier than usual. The seed grains were dull as the active call for them was about over for this season.

LEGGÉ HEADS SEED CAMPAIGN

A special drive for seed wheat trading was started last month in Chicago by Alexander Legge, chairman of the Federal Farm Board.

In conference with Mr. Legge at Chicago was Dr. J. L. Coulter, chief economist of the Federal tariff commission. The plan evolved by them calls for a systematic campaign to persuade farmers to abandon wheat acreage and take on the production of flax and barley. Seed for the latter crop is being exchanged for seed wheat at an attractive rate of exchange.

The tariff commission economist some time ago outlined to the farm board the seed trade suggestion as a practical way to get immediate action on a wheat acreage cut program. He suggested that a reduction of 2,000,000 acres in Minnesota and the Dakotas would approach the 10 per cent cut urged by the farm board.

If the board would help the farmers get seed to plant 1,000,000 of these acres to flax and the other million to barley, rye, and oats with alfalfa and sweet clover, he said, the reduction would be accomplished with profit to the farmer and benefit to the soil.

So forcibly did Dr. Coulter's idea appeal to the farm board that Mr. Legge asked the author to loan his services for a two weeks' trip to help put it into

effect. He accepted and after meeting Mr. Legge in Chicago proceeded to confer with authorities in the Northwest.

Prior to his appointment on the tariff commission Dr. Coulter was head of the North Dakota Agricultural College and is familiar with wheat conditions in the Northwest.

Just how far the farm board will go financially toward buying and exchanging seeds with the farmers, at a possible loss to itself apparently has not been determined but indications at the Washington offices are that it stands ready to contribute a sizable sum.

SEED TESTING URGED

Fred K. Sale, secretary of the Indiana Grain Dealers Association, discusses the necessity of testing seed corn in a special bulletin to members this month.

"Such tests as have already been made for seed corn," he says, "have proven very unsatisfactory. Generally speaking, seed corn selected before the zero weather of November 29, and properly dried, is giving good germination tests. Much of the corn selected after that date is found to be dead or very weak in vitality. In some parts of this state it is questionable that sufficient good seed corn will be available. Grain dealers should immediately assist their farmer customers in making proper tests of their seed corn, or at least immediately urge that proper tests be made. If necessary, determine your local needs for seed corn and buy good certified seed for your customers."

SEED SOURCE VITAL TO BEAN TRADE PROGRESS

Use of viable seed was recommended by W. J. Zaumeyer, of the Department of Agriculture, as the most satisfactory way of controlling the bean diseases of anthracnose, bacterial blight, and mosaic, in a recent address before the bean section of the National Canners Association, meeting in Chicago.

"Seed source is of utmost importance," said Mr. Zaumeyer. "When diseased seed is planted and proper weather conditions prevail for development of the disease, the affected seedlings may act as centers for much of the secondary spread. If this factor can be eliminated it is evident that the amount of dissemination will be greatly reduced. It is a fact that certain sections of the semiarid West where much of the canning-bean seed is grown produce a crop that is free from one or another of the diseases."

The large seed companies operating in the Middle West are appreciative of the importance of clean seed and are co-operating in every possible way to reduce the percentage of diseased seed. Since the canners in general are equally interested in the importance of clean seed, it is believed that with their continued co-operation a steady improvement will be made.

CORRECT LABELING CHIEF OBJECT OF HOOSIER SEED LAW

The Indiana Seed Law is essentially a correct labeling law. The law does not prevent the sale of poor seed. It merely requires that definite information be placed on the label in order that the purchaser may decide for himself whether he wishes to use good seed or poor seed. In order that the necessary information may be available the law requires that the seed be labeled with official Indiana State Labels showing the minimum percentage of purity and germination and the maximum number of each of the noxious weed seeds per pound.

The purpose of the law is to give the purchaser sufficient information to enable him to buy good

seed and also to protect the honest and reliable seed dealer and farmer from the practices of the unscrupulous, dishonest and careless seedsman. The wholesale seedsman is required to attach at least one state label to each package of seed delivered to the retail seedsman. The retail seedsman is then required to place sufficient labels, properly filled out, on each package to cover the full weight of the seed before the seed is offered or exposed for sale.

NEW RYE: PEDIGREE 5

A new high-yielding variety of rye characterized by uniform light colored kernels has been developed by B. D. Leith, at the University of Wisconsin, and has been released to a few co-operating farmers in the important rye producing areas of the state. It is expected that seed from these increase fields will be available for dissemination this year. The new variety goes under the title "Pedigree 5."

In the development of this improved variety Mr. Leith has made use of the principles of inbreeding and rigid selection. Emphasis has been placed on plants which will retain their vigor when self-pollinated, which will produce large sized heads and stiff straw, and which will be superior to the common strains of rye in that the tendency to produce sterile unfilled heads is very greatly reduced. Because Wisconsin rye millers prefer light colored rye instead of green, selection was made for white kernels.

'BETTER TEST THAT SEED CORN' FEDERAL SEED EXPERTS WARN

It is imperative that corn belt farmers test the seed corn they intend to plant in 1930, says the United States Department of Agriculture. Otherwise serious losses are probable. Preliminary reports already reveal serious injury to corn intended for seed and so handled that it would have been excellent in ordinary seasons. Other corn intended for planting which received no special care is known to be utterly unfit for seed.

This condition, say specialists of the department, has been brought about by the wet fall followed by temperatures well below zero. Some corn did not dry enough, even when hung in well-ventilated places. Consequently it could not stand the hard freezing. Furthermore, the low temperatures extended farther south than usual so that seed corn as far south as Oklahoma and Arkansas must be considered questionable until tested.

The sooner a germination test of the seed corn intended for planting is made, the better, warn the authorities.

SEARCH FOR SOYBEAN SEED IN JAPAN IS SUCCESSFUL

W. J. Morse, forage-crop specialist, Bureau of Plant Industry, United States Department of Agriculture, who has been in Japan for several months collecting new varieties of soy beans, reports that to date he has collected more than 5,000 lots, representing every type of soy beans grown in Japan.

A large number of soy bean introductions have been sent into the United States by the Foreign Plant Introduction Office of the department in the last 20 years. Now the crop has established itself as one of major importance in this country, with a value of \$70,000,000 for 1929. Due to increased utilization as a forage crop, for production of soy

bean oil and meal, and as a human food, it seems likely that the soy bean will continue to grow in importance in the United States.

Soy bean oil is becoming an important item in the manufacture of soap, paints, linoleum, rubber substitutes, and glycerin in this country. When properly refined, the oil may be used in almost any foodstuff in which a vegetable oil is used. In China one of the principal uses of soy bean oil is for human food, but it is also used in the manufacture of soap, varnish, printing ink, paints, candles, waterproof goods, and for lighting and lubrication.

With increase in the demand for soy bean oil from American industries, efforts are being made by the Department of Agriculture to develop varieties with a high oil content. Where the beans are grown as a forage crop, especially for hogs, there is a demand for varieties with a low oil content, as the oil has a tendency to cause the meat to be soft, especially where large quantities of the beans are fed.

Samples from every lot of seed collected by Mr. Morse will be planted at the United States experiment farm at Arlington, Va., this spring, and when the seed is harvested tests will be made for oil content. In this way it is hoped that selections may be made which will ultimately develop into varieties with a wide range of oil content. Mr. Morse writes that the Japanese use the soy bean in a number of ways in their diet. They grind the beans and make flour, they serve the green beans as we would green lima beans, and they cook the dried beans in a manner similar to navy beans. Besides this, they make soy sauce, soy bean curd, beverages, and bean sprouts from the soy bean. He believes that the use of soy beans as a human food in this country will increase steadily.

Mr. Morse has spent some time in Tokio, studying the Japanese methods of utilizing soy beans. While he expects soy beans to grow in favor as a feed for livestock and food for people, he feels that the largest future development of the crop in the United States will be in the utilization of the oil and meal in industry. Samples of the seed collected in Japan will be sent to some of the state experiment stations for trial, but will not be available for distribution to individuals.

A SEED SCHOOL

The net result of the North Dakota Seed Growers' School is an extra 500,000 bushels of pure seed. Agencies co-operating with the school are the Northwestern Crop Improvement Association and the North Dakota Agricultural College. Over 500 North Dakotans are now listed as pure-seed wheat growers. In 1928 there were only 218 such growers registered.

This state is planning on crop improvement through good seed. This is the foundation of producing good crops, yet of course the North Dakota

BUYERS AND SELLERS

Bag Lots or Carloads

Alfalfa, Clovers, Grasses, Field Seeds

ED. F. MANGELSDORF & BRO.

Wholesale Field and Grass Seeds

ST. LOUIS, MISSOURI

SEEDS BETTER SEEDS; BETTER CROPS
PRUNTY SEED & GRAIN CO.
14 South Main St. SAINT LOUIS

CHAPMAN'S Red Top

MEAT SCRAPS - - 50% PROTEIN

Digester Tankage - - 60% Protein—Great Specialty

SIDELINES FOR ELEVATORS

Special Odorless Bone Meal—Salt

RAW BONE MEAL — CALCIUM CARBONATE



50% Protein



60% Protein

Write or Wire
RIVERDALE PRODUCTS CO.

Offices: 105 West Adams Street, Chicago

Agricultural College promotes good culture and develops knowledge of soils, the same as other states. North Dakota, however, is the only state that has a seed school for farmers. The big expansion of certified growers from 92 in 1927 to over 500 in 1929 is looked upon as a real achievement.

SEED CARRIES NEMATODE GALLS

The nematode disease of wheat and rye is controlled most readily by sowing only uninfested seed on uninfested land. The fact that the nematode galls may be carried for great distances in seed grain is another argument for the use of pure seed from the stocks of regular dealers.

The nematode disease of wheat and rye occurs in six states (Maryland, Virginia, West Virginia, North Carolina, South Carolina, and Georgia) and is gradually spreading. It may be present in many localities where it has not yet been recognized.

The disease may be recognized in grain or seed by the presence of hard galls, which often are mistaken for weed seeds or other impurities. These galls contain the nematodes (tiny worms) which attack wheat, rye, emmer, and spelt. The nematodes do not live more than one year in the soil in the absence of crops of wheat, rye, emmer, or spelt.

The Henry Field Seed Company, Shenandoah, Iowa, is reorganizing and increasing its capital to over \$1,000,000.

SITUATION WANTED

WANTED

Position as manager for a farmers' elevator company. Have had 10 years' experience in elevator work and can give best of references. Can come at once. A. P. RANKIN, Claire City, S. D.

WANTED

Position as manager of country elevator, farmers or line company. Prefer Iowa or Illinois. Can give best of references and bond; 20 years' experience. E. J. FUNK, Garden City, Kan.

\$100 Reward Paid

for information which results in employment with salary attached. Experienced, successful record as country buyer and traveling auditor of line elevators. Prefer connection handling flour and feeds or other side lines. Middle West but can go anywhere at once. References. Address W. B. Burns, Y. M. C. A. Hotel, Chicago, Ill.

For Sale

MACHINERY

FOR SALE

Car loader, air blast new; very best on the market. Reasonable. Write or wire STANDARD MILL SUPPLY COMPANY, 502 Waldheim Bldg., Kansas City, Missouri.

BARGAIN FOR QUICK SALE

Standard 500-bushel hopper scale with 24-ft. extension rod down to beam on third floor below. In perfect order and cheap. HOLYROOD MILL COMPANY, Holyrood, Kan.

FOR SALE

Pulleys, 1,000; all sizes, solid cast iron, wood and steel split. Elevator belts and buckets and supplies. STANDARD MILL SUPPLY COMPANY, 502 Waldheim Building, Kansas City, Mo.

ELEVATORS AND MILLS

PRICED TO SELL TO SETTLE ESTATE

Wisconsin grain elevator, potato house, hay house, coal buildings, etc. On C. & N. W. R. R., direct to Chicago and St. Paul. In good farming county. MRS. J. NIEBUHR, Fall Creek, Wis.

MUST SELL TO SETTLE AN ESTATE

South Colorado 30,000-bushel elevator and feed mill, in the best agricultural section in U. S. Doing a good business. Wonderful climate for T. B. or Asthmatic people. Soft artesian water. If interested, write M. SONDES, Center, Colo.

Miscellaneous Notices

WANTED

To hear from owner having elevator or other business for sale. Give particulars and cash price. Write JOHN BLACK, Box 30, Chippewa Falls, Wis.

WANTED

Experienced grain buyer desires position with responsible grain company or individual. Competent to handle side lines. References. WM. ALEXANDER, Spencer, S. D.

PORTLAND, OREGON

Is an ideal location for that new mill and elevator of yours.

Portland is in the heart of the agricultural region of the Pacific Northwest. It also has an abundance of cheap, hydroelectric power for manufacturing purposes, good ocean and railway shipping facilities and a fair supply of skilled labor, practically all of which is non-union.

Portland is also an ideal place to live. It has a mild climate, good water and plenty of nice hotels, apartment houses and homes. Also good schools, theaters, libraries, clubs and parks.

I would be pleased to serve you in the location, design and construction of that new mill of yours.

HENRY BLACK

Complete Building Construction

383 Pittock Block Portland, Oregon

Telephone Broadway 8060

Iron Workers, Cement Workers, Bricklayers, Carpenters, Roofers, Plumbers, Electricians, Cabinet-makers, Painters and Paperhangers; also Real Estate Bonds and Mortgages.

B **ENGINEERS & BUILDERS** **B**
of
GRAIN ELEVATORS,
FLOUR MILLS,
AND ASSOCIATED
BUILDINGS.
BURRELL
ENGINEERING & CONSTRUCTION CO.
21ST FLOOR
DAILY NEWS PLAZA
CHICAGO - ILLINOIS **B**

Save Time and Energy

If you have occasion to convert grain weights into their equivalents of bushels, you will find all calculations worked out for you in

Ropp's Calculator

Price \$1.00

Mitchell Bros. Publishing Co.

431 So. Dearborn St.

Chicago, Ill.

**BOARD
OF
TRADE**

CHICAGO

**GRAIN
RECEIVERS**

Lamson Bros. & Co.
Grain
1874 Commission 1930
Merchants
Fifty-six Years of Service in the Grain Trade
166 W. Jackson Boul.
and
439-445 S. Clark St.
Chicago

DOERN-SCARRITT-HANNAH CO.
FORMERLY
POPE & ECKHARDT CO.
(ESTABLISHED 1873)
COMMISSION MERCHANTS
111 W. JACKSON STREET
CHICAGO

SEVENTY-SEVENTH ANNIVERSARY YEAR
J. H. DOLE & COMPANY
ESTABLISHED 1852
George S. Dole, President Frank Haines, Sec. & Treas.
Commission Merchants, Grain and Seeds
We solicit your consignments and hedging orders in futures
327 South La Salle Street, Chicago, Ill.
Branch Offices: 15 Board of Trade, Peoria, Ill.
303 Merchants Exchange Bldg., St. Louis, Mo.

We Buy
Wheat—Corn—Oats—Barley
Send Samples
The Quaker Oats Co.
Cereal Millers
Grain Dept. 80 East Jackson Boulevard
CHICAGO

Rosenbaum Grain Corporation
Grain Merchants—Exporters—Importers
332 South La Salle St.
CHICAGO, ILLINOIS
Cash and Futures Private Wires

E. W. BAILEY & CO.
COMMISSION MERCHANTS
GRAIN, SEEDS AND PROVISIONS
843-47 Rand McNally Bldg. CHICAGO

H. M. PAYNTER
With ROGERS GRAIN COMPANY
Grain Commission
Correspondence Solicited
Postal Telegraph Building CHICAGO

RUMSEY & COMPANY
FOUNDED 1867
COMMISSION MERCHANTS
538 S. CLARK ST.,
CHICAGO

**Robinson Telegraphic
Cipher**
REVISED EDITION
Cloth Binding \$2.00
Leather Binding 2.25
**MITCHELL BROTHERS
PUBLISHING COMPANY**
431 S. Dearborn Street Chicago, Ill.

J. C. Shaffer Grain Co.
GRAIN MERCHANTS
CHICAGO

Clement, Curtis & Co.
Illinois Merchants Bank Bldg., Chicago
Members of all principal Exchanges.
Private wire service to all leading cities
in this country.

**MERCHANTS'
EXCHANGE**

ST. LOUIS

**GRAIN
RECEIVERS**

Nanson Commission Co.
(INCORPORATED)
GRAIN AND HAY
202 Merchants Exchange
ST. LOUIS Consignments a
Specialty
Write Us for Full
Information on
St. Louis Markets

Toberman Grain Company
GRAIN, HAY AND SEEDS
A long established house, energetic, enter-
prising and alert for your interests.
Let us handle your consignments
300 Merchants Exchange St. Louis, Mo.

**"THE CONSIGNMENT HOUSE
OF ST. LOUIS"**
GRAIN, HAY and GRASS SEEDS
Picker & Beardsley Com. Co.
125 MERCHANTS EXCHANGE

CORN
EXCHANGE

✂ **BUFFALO** ✂

GRAIN
RECEIVERS

Send your consignments to
Seymour-Wood Grain Co.

BUFFALO,

N. Y.

Lewis Grain Corp.

A good firm to consign to

Corn—Oats—Soft Wheat—Barley

BUFFALO

NEW YORK

J. G. McKillen, Inc.,
RECEIVERS

Consignments a Specialty

BUFFALO

NEW YORK

McConnell Grain Corporation

Strictly Commission and Brokerage

Buffalo

New York

YOU Can keep in touch with
the news and reports of
the Grain and Elevator
world by reading the "American
Grain Trade."

SUBSCRIBE NOW—\$1.00 A YEAR.

PRODUCE
EXCHANGE

✂ **TOLEDO** ✂

GRAIN
RECEIVERS

EVERY SHIPPER Should Receive

Southworth's daily bids—

WHEAT, CORN, OATS, RYE

Southworth & Company, Toledo, Ohio

JOHN WICKENHISER & CO.

Wholesale Grain Dealers

TOLEDO, OHIO

We make track bids and quote delivered prices.
Solicit consignments of Grain and Clover Seed.

Members Toledo Produce Exchange and Chicago
Board of Trade.

Robinson's Telegraphic Cipher

REVISED AND ENLARGED EDITION

Cloth Binding\$2.00
Leather Binding 2.25

MITCHELL BROS. PUBLISHING CO.

431 S. Dearborn St., CHICAGO, ILL.

BOARD
OF
TRADE

✂ **INDIANAPOLIS** ✂

GRAIN
RECEIVERS

The Cleveland Grain Co.

OPERATING FIVE TERMINAL ELEVATORS

Mighty Good Consignment Service

Ed. K. Shepperd, Manager

H. E. Kinney Grain Co.

COMMISSION—BROKERAGE

A Card Ad

in the
"American Grain Trade"

has Excellent Display and
is Always Easy to Find.

CHAMBER
OF
COMMERCE

✂ **MINNEAPOLIS** ✂

GRAIN
RECEIVERS

CEREAL GRADING COMPANY
GRAIN MERCHANTS

Milling Wheat Any Protein Required

Choice Milling Rye

Feeding Grains All Kinds

We have remodeled and enlarged our Elevator "L" and now have about 1,000,000 bushels capacity and can give our trade better service than ever before. If you want good grain and quick service, write or phone us for prices.

612 Chamber of Commerce, Minneapolis, Minn.

Robinson Telegraphic Cipher

Revised Edition

Cloth Binding\$2.00
Leather Binding 2.25

**MITCHELL BROTHERS
PUBLISHING COMPANY**

431 S. Dearborn Street

Chicago, Ill.

BOARD
OF
TRADE

KANSAS CITY

GRAIN
RECEIVERS

BOOKS FOR
GRAIN DEALERS

WALLS, BINS AND GRAIN ELEVATORS, by
Milo S. Ketchum. Illustrated, 556 pages.
Price\$5.00
ROPP'S CALCULATOR, new and improved edi-
tion, with complete grain tables, and other
invaluable discount and stock tables.
Price\$1.00
ROBINSON'S TELEGRAPHIC CIPHER, re-
vised and enlarged. Price.....\$2.00
UNIVERSAL GRAIN CODE, and Feed Mill
Supplement. Price\$3.00

Any of the above sent postpaid
on receipt of price.

MITCHELL BROS. PUBLISHING CO.
431 S. Dearborn St. Chicago, Ill.

GET OUR BIDS TO ARRIVE



CONSIGNMENTS

BOARD
OF
TRADE

PEORIA

GRAIN
RECEIVERS

Louis Mueller, President F. W. Mueller, Sec. & Treas.
MUELLER GRAIN COMPANY
(Incorporated)
Receivers and Shippers **GRAIN**
We Solicit Your Consignments of Grain
Room 39-41 Chamber of Commerce, Peoria, Ill.

P. B. & C. C. MILES
Established 1875 Incorporated 1910
PEORIA, ILL.
Handling Grain on Commission
Our Specialty

W. W. Dewey & Sons
GRAIN COMMISSION
26 Chamber of Commerce
PEORIA - - ILL.

GRAIN
&
HAY
EXCHANGE

PITTSBURGH

GRAIN
RECEIVERS

HARPER GRAIN CO.
Wabash Building
Modern elevator facilities
at your command.

FUMIGATION METHODS

By PROF. WILLIS G. JOHNSON
A complete practical treatise on fumigating grain elevators, flour mills, ware-
houses, etc. 313 pages. Well illustrated. Price \$2.00.
MITCHELL BROS. PUBLISHING CO., 431 S. Dearborn St., Chicago

GRAIN
RECEIVERS

OTHER MARKETS

GRAIN
RECEIVERS

CRAWFORDSVILLE, IND.

CRABBS REYNOLDS TAYLOR CO.
Crawfordsville, Ind.
GRAIN
Clover and Timothy Seeds
Get in touch with us.

The Real Market Place

for grain men is centered in
the advertising columns of the

“American Grain Trade”

LEADING GRAIN RECEIVERS IN ALL MARKETS

BUFFALO, N. Y.

Lewis Grain Corporation, grain merchants, consignments.
McConnell Grain Corporation, commission and brokerage.*
McKillen, Inc., J. G., receiver.*
Seymour-Wood Grain Co., consignments.*

CEDAR RAPIDS, IOWA

Wilder-Murrel Grain Co., wholesale, grain, seeds, feeds.*

CHICAGO, ILL.

Bailey & Co., E. W., commission merchant.*
Brennan & Co., John E., commission merchants.*
Bridge & Leonard, hay, grain.*†
Clement, Curtis & Co., commission merchants.*
Doern-Scarritt-Hannah Co., grain and seeds.*
Dole & Co., J. H., commission merchants.*
Hoit & Co., Lowell, com. grain, seeds.
Lamson Bros. & Co., commission merchants.*
McKenna & Strasser, com. merchants.*
Norris Grain Co., grain merchants.*
Paynter, H. M., grain commission.
Quaker Oats Co., wheat, corn, oats, barley, rye.
Rosenbaum Grain Corporation, grain merchants.
Rumsey & Co., grain commission.*
Shaffer Grain Co., J. C., grain merchants.*

CLEVELAND, OHIO

The Cleveland Grain Co., receivers and shippers.*†
Shepard, Clark & Co., receivers, shippers, grain, millfeed, buckwheat.*

CRAWFORDSVILLE, IND.

Crabbs-Reynolds-Taylor Co., grain, seeds.*†
*Members Grain and Feed Dealers' National Association.

DECATUR, ILL.

Baldwin & Co., H. I., grain dealers.*

DENVER, COLO.

Ady & Crowe Mercantile Co., grain, beans and feed.

GREEN BAY, WIS.

Green Bay Elevator Co., receivers and shippers of grain, flour and feed.

GREENVILLE, OHIO.

Grubbs Grain Co., E. A., wholesale grain, wheat, corn, oats.*

INDIANAPOLIS, IND.

The Cleveland Grain Co., grain dealers.*
Kinney, H. E., Grain Co., grain, hay, feed.*†

KANSAS CITY, MO.

Moore-Seaver Grain Co., corn and oats.*

MILWAUKEE, WIS.

Kamm Co., P. C., grain merchants.*

MINNEAPOLIS, MINN.

Cereal Grading Co., grain merchants.*
Cargill Elevator Company, milling wheat.*

OMAHA, NEB.

Uptike Grain Co., receivers and shippers.*
Trans-Mississippi Grain Co., grain merchants.*
Butler-Welsh Grain Co., grain commission merchants.*
Omaha Elevator Co., receivers and shippers of grain.*

†Members National Hay Association.

PEORIA, ILL.

Cole Grain Co., Geo. W., receivers and shippers.*
Dewey & Sons, W. W., grain commission.*
Miles, P. B. & C. C., grain commission.*†
Mueller Grain Co., receivers and shippers.*

PITTSBURGH, PA.

Harper Grain Co., grain commission.

ST. LOUIS, MO.

Mangelsdorf & Bro., Ed. F., seeds.
Nanson Commission Co., receivers, shippers.*†
Picker & Beardsley Com. Co., grain, hay.*†
Prunty, Chas. E., grain and seeds.
Toberman Grain Co., grain, hay, seeds.*†

SIDNEY, OHIO

Custenborder & Co., E. T., carlot grain.*
Wells Co., J. E., wholesale grain, seeds.*

SIoux CITY, IOWA

Flanley Grain Co., grain receivers.
Terminal Grain Corporation, grain receivers.

TIFFIN, OHIO

Sneath-Cunningham Co., grain and seeds

TOLEDO, OHIO

De Vore & Co., H. W., grain, seeds.*
Southworth & Co., grain and seeds.*†
Wickenhiser & Co., John, grain dealers.*

WINCHESTER, IND.

Goodrich Bros., wholesale grain, seeds, hay.*†

WOOSTER, OHIO

The Wooster Milling & Grain Co., grain dealers, operating 11 elevators.*

“FEEDS AND FEEDING”

By W. A. HENRY and F. B. MORRISON of the Dept. of Agriculture, University of Wisconsin

An invaluable book of reference which every feed manufacturer and dealer should have to solve his own and the farmer's problems.

Contains formulas of feeds for many purposes and instructions for making scientific rations from any combination of ingredients at hand.

770 pages — \$4.00

MITCHELL BROS. PUBLISHING CO., 431 S. Dearborn St., Chicago, Ill.

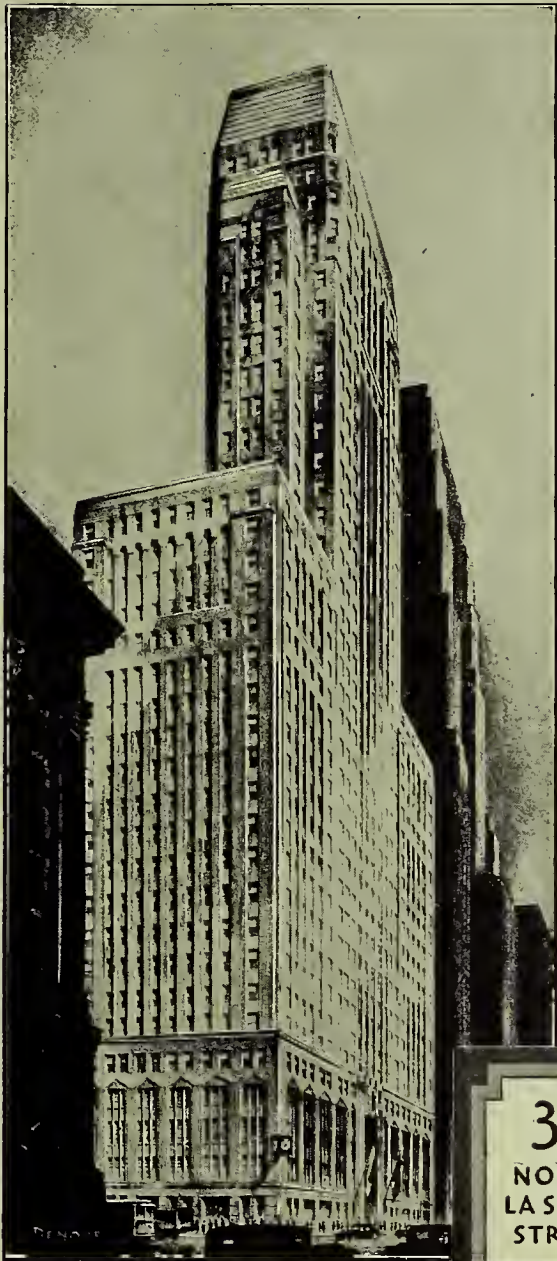

Completely Equipped
to Serve You

FOREMAN-STATE NATIONAL BANK
FOREMAN-STATE TRUST AND SAVINGS BANK
CHICAGO

RESOURCES EXCEED 200 MILLION DOLLARS

DON'T WAIT
FOR THE
ENGINE and
SWITCHING CREW



INSTALL A
WELLER CAR PULLER

Move the cars when you are ready. Operates at the touch of a button.
Sizes to pull from 1 to 30 cars
Send for Car Puller Circular

Send us your inquiries for
GRAIN HANDLING EQUIPMENT
WEBSTER MFG. CO.-WELLER MFG. CO.
1856 N. Kostner Ave. CHICAGO, ILL.

LIGHTNING
DESTROYS

THOUSANDS OF DOLLARS
WORTH OF PROPERTY
ANNUALLY

Buildings Properly Protected
Are Safe

Ask Your Mill Mutual Insurance Office for Details
of Construction and Insurance Savings

Or Address the

Mutual Fire Prevention Bureau
230 E. Ohio St. Chicago, Ill.

Make Feed Grinding More Profitable!

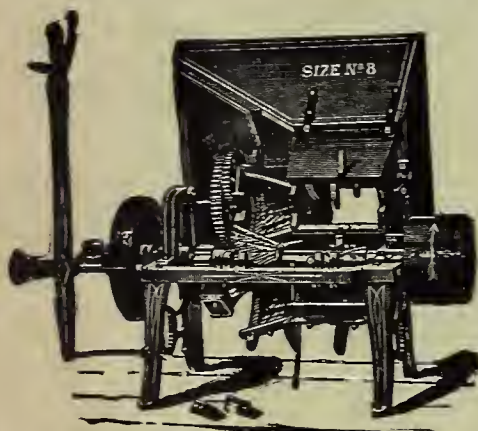

Bowsher's "Combination"
Mills do this

Because their large capacity, cone-shaped grinders and positive self ear feeders are properly designed to direct every ounce of power energy to the actual reduction of the grain.

Crush and Grind ear corn, husked or unhusked, alone or mixed with any kind of small grain in any desired proportion. Reduce the material to any fineness desired for feeding purposes.

11 Sizes, 2 to 25 H.P.

Sold with or without Sacking Elevator.

The N. P. Bowsher Co., South Bend, Ind.

THE CUTLER STEAM DRYER
IN SUCCESSFUL USE OVER 50 YEARS DRYING

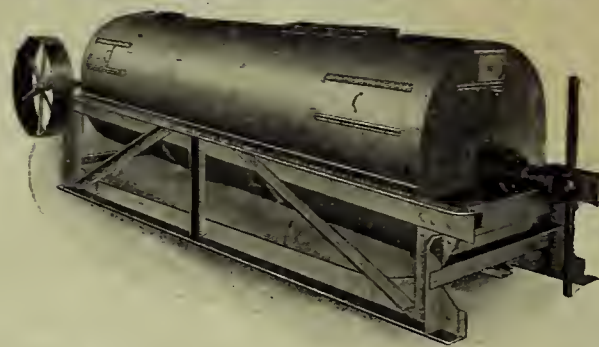

CORN MEAL, HOMINY,
STARCH
ALL CEREAL PRODUCTS
AND VEGETABLE
OIL-BEARING SEEDS
ALSO SAND, COAL
DUST, GRAPHITE,
CLAY, ORES, ETC.

SOLD BY ALL
MILL
FURNISHERS

CUTLER DRYER CO., North Wilbraham, Mass.

Great Western Wheat Washer and Drier

Earns
Money
Rapidly

A New and
Improved Machine

Write us

Manufactured by

GREAT WESTERN MFG. COMPANY
LEAVENWORTH, KANS. KANSAS CITY, MO.

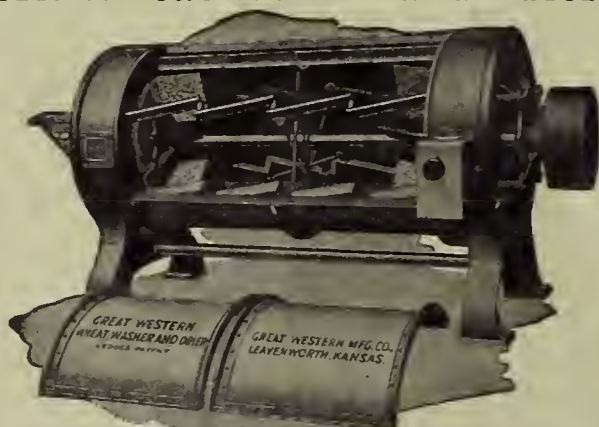

When you "hop on a Humphrey"
you save time,
energy and promote
efficiency

Humphrey
Employees'
Elevator

Write—
Humphrey
Elevator Co.

800 Division St., Faribault, Minn.

