

THE · RAILWAY
LOCOMOTIVE

VAUGHAN · PENDRED

M. INST. MECH. E. M. I. & S. INST.

WESTMINSTER SERIES

LIBRARY
OF THE
UNIVERSITY OF CALIFORNIA.

Class

The D. Van Nostrand Company

intend this book to be sold to the Public
at the advertised price, and supply it to
the Trade on terms which will not allow
of reduction.

The "Westminster" Series

THE RAILWAY LOCOMOTIVE

THE RAILWAY LOCOMOTIVE

WHAT IT IS AND WHY
IT IS WHAT IT IS

BY

VAUGHAN PENDRED, M.Inst.Mech.E. M.I. & S.Inst.

(1)



NEW YORK

D. VAN NOSTRAND COMPANY

23 MURRAY AND 27 WARREN STREETS

1908

TJ605
P5

GENERAL

CONTENTS

SECTION I

THE LOCOMOTIVE ENGINE AS A VEHICLE

CHAP.		PAGE
I.	FRAMES	1
II.	BOGIES	15
III.	THE ACTION OF THE BOGIE	27
IV.	CENTRE OF GRAVITY	33
V.	WHEELS	40
VI.	WHEEL AND RAIL	54
VII.	ADHESION	58
VIII.	PROPULSION	66
IX.	COUNTER-BALANCING	73

SECTION II

THE LOCOMOTIVE AS A STEAM GENERATOR

X.	THE BOILER	84
XI.	THE CONSTRUCTION OF THE BOILER	91
XII.	STAY BOLTS	97
XIII.	THE FIRE-BOX	102
XIV.	THE DESIGN OF BOILERS	114
XV.	COMBUSTION	121
XVI.	FUEL	127
XVII.	THE FRONT END	136
XVIII.	THE BLAST PIPE	144
XIX.	STEAM	152
XX.	WATER	158
XXI.	PRIMING	162

CHAP.		PAGE
XXII.	THE QUALITY OF STEAM	169
XXIII.	SUPERHEATING	171
XXIV.	BOILER FITTINGS	180
XXV.	THE INJECTOR	187

SECTION III

THE LOCOMOTIVE AS A STEAM ENGINE

XXVI.	CYLINDERS AND VALVES	198
XXVII.	FRICITION	209
XXVIII.	VALVE GEAR	213
XXIX.	EXPANSION	217
XXX.	THE STEPHENSON LINK MOTION	223
XXXI.	WALSCHAERT'S AND JOY'S GEARS	230
XXXII.	SLIDE VALVES	236
XXXIII.	COMPOUNDING	239
XXXIV.	PISTON VALVES	246
XXXV.	THE INDICATOR	250
XXXVI.	TENDERS	263
XXXVII.	TANK ENGINES	271
XXXVIII.	LUBRICATION	282
XXXIX.	BRAKES	285
XL.	THE RUNNING SHED	288
XLI.	THE WORK OF THE LOCOMOTIVE	294

STANDARD WORKS ON THE LOCOMOTIVE ENGINE	305
INDEX	307

LIST OF ILLUSTRATIONS

FIG.	PAGE
1. STEPHENSON'S INSIDE AXLE BOX	5
2. STEPHENSON'S STANDARD LOCOMOTIVE, 1838	7
3—16. THE DEVELOPMENT OF THE BAR FRAME	9
17. AXLE BOX	11
18. COMPENSATING LEVER	12
19. BISSELL BOGIE	15
20—21. GREAT NORTHERN SWING LINK BOGIE	16
22. FLANGING PRESS	18
23. OPEN END BOGIE	19
24. CLOSED END BOGIE	19
25. STANDARD BOGIE, GREAT EASTERN RAILWAY	20
26. STANDARD BOGIE, GREAT EASTERN RAILWAY	21
27. DETAILS BOGIE, GREAT EASTERN RAILWAY	21
28. SWING LINK BOGIE, GREAT WESTERN RAILWAY	22
29. TRAVERSING LEADING AXLE, LANCASHIRE AND YORKSHIRE RAILWAY	24
30. MR. BALDRY'S RULE FOR FINDING THE CENTRE FROM WHICH TO STRIKE THE CURVE OF A RADIAL AXLE BOX	25
31. CENTRIFUGAL EFFORT	34
32. TIRE-ROLLING MILL	41
33. TIRE SECTIONS, LANCASHIRE AND YORKSHIRE RAILWAY	46
34. STANDARD TIRE AND RAIL, GREAT EASTERN RAILWAY	47
35. ADAMS' ELASTIC WHEEL	54
36. CENTRIFUGAL COUPLES	75
37. RIGG'S DIAGRAM	77
38. WIRE TEST FOR HAMMER BLOW	81
39. SECTIONAL DIAGRAM OF BOILER	85
40. RADIAL STRESS	91
41—44. EXPLODED BOILER	100
45. GIRDER STAY	102
46. BELPAIRE BOILER, "STAR" CLASS, GREAT WESTERN RAILWAY	104
47. FIRE HOLE	107
48. EXPANSION SLIDE	114
49. DRUMMOND'S WATER TUBE FIRE-BOX	118
50. SMOKE-BOX, LONDON AND SOUTH WESTERN RAILWAY	140
51. SMOKE-BOX, SOUTH EASTERN AND CHATHAM RAILWAY	141

FIG.		PAGE
52.	SMOKE-BOX, SOUTH EASTERN AND CHATHAM RAILWAY	142
53.	STANDARD FRONT END	149
54—55.	BALDWIN SMOKE-BOX	150
56.	HEAT PEG	153
57.	THE PEABODY CALORIMETER	166
58—60.	THE SCHMIDT SUPERHEATER	175
61.	AMERICAN THROTTLE VALVE	180
62.	THROTTLE VALVE DETAILS	181
63.	SAFETY VALVE	183
64.	RAMSBOTTOM'S SAFETY VALVE	184
65.	SECTION OF INJECTOR	191
66.	SELF-STARTING INJECTOR	194
67.	SLIDE VALVE	200
68.	CYLINDER WEAR	202
69.	ACTION OF CONNECTING ROD	204
70.	JOY'S VALVE GEAR	205
71.	CROSS-HEAD, GREAT EASTERN RAILWAY	207
72.	GAB GEAR	214
73.	STEPHENSON'S LINK MOTION	216
74.	EXPANSION CURVE	218
75.	ANGULAR ADVANCE	223
76—78.	WAINWRIGHT'S REVERSING GEAR	226—228
79.	WALSCHAERT'S GEAR	232
80.	JOY'S GEAR	233
81.	SMITH'S PISTON VALVE	248
82.	THOMPSON INDICATOR WITH OPEN SPRING	251
83.	INDICATOR DIAGRAMS	255
84.	PICK-UP APPARATUS, LONDON AND NORTH WESTERN RAILWAY	265
85.	FEED WATER-HEATER, LONDON AND SOUTH-WESTERN RAILWAY	269
	COLLISION AT BINA, GREAT INDIAN PENINSULA RAILWAY	272
86—87.	FINDING THE CENTRE OF GRAVITY OF A TANK ENGINE	274—275
88—89.	DERAILMENTS	278—279
90.	RAMSBOTTOM GRAVITY LUBRICATOR	283
91—93.	TRACTOMETER DIAGRAMS	298, 299
94.	IVATT'S SPEED DIAGRAM	301

INTRODUCTION

THE literature of the railway locomotive engine is already so copious that I think some explanation of how this book came to be written is desirable.

It forms one of a series of volumes, the idea of publishing which originated with Messrs. Archibald Constable & Co. In the present day specialisation is universal, and in no profession does it prevail more than in that of engineering. This will not appear remarkable when we recognise the enormous range of subjects with which the engineer has to deal.

The "Westminster" series is intended in a sense to bridge over the gaps left by specialisation. Thus the marine engineer may have but a very slight knowledge of electrical engineering, and the civil engineer may be comparatively ignorant concerning the locomotives which run on the railways which he makes. But engineers should have—the younger members of the profession in particular need to have—a great deal of information in common, and all perfectly understand technical language.

Speaking then of my own work, I may say that I hope engineers in any branch of the profession who may read this book will find in it information which they did not possess before. The books which have hitherto been written about the locomotive engine are all either strictly specialised or very "popular." None of them go far into the life of the locomotive engine. The technical treatise deals with the locomotive almost altogether as a machine. Its parts are described, but the reasons why they assume particular shapes, and why one shape is better or worse than another are not dwelt upon, and nothing is said about the daily life of the engine. To use a metaphor, the locomotive is handled by its authors anatomically, not physiologically.

I have in this volume attempted, I hope with some success, to

break new ground. Of the history of the locomotive I have written next to nothing. I have endeavoured to describe the modern locomotive, using the words in the generic sense, and to explain why it is what it is.

That I have left much unsaid that might have been said with advantage is a very evident proposition. My excuse lies in the dimensions of this book, and the fact that it is not intended to be in any sense or way a complete treatise on railway locomotives. My purpose has been to make the locomotive intelligible; to show what it means; the mechanical and the physical phenomena on which it depends for its action, and the objects carefully kept in view by those who design, construct, and employ it as one of the most useful servants of mankind. I do not think this has been done before with anything like the same simplicity of intention.

There are very wide differences in externals, but in essentials all locomotives without exception, are the same. They are survivals of the fittest. The conditions of working are comparatively inflexible; and the more closely any type of locomotive conforms to these conditions the greater are the chances of its success. Yet the influence of nationality and climate have made themselves felt; and various designs may be regarded as indigenous to particular countries. The British locomotive is, above all others, simple, strong, and carefully finished. It is intended to last as long as possible. The American locomotive is the incarnate spirit of opportunism. It is intended to meet the wants of the moment; a long life for it is neither desired nor sought. It is held that before an engine can wear out it will be superseded by something bigger, and more suitable to new requirements and conditions. In Europe complication is favoured rather than disliked. The workmanship is as a rule admirable; but simplicity is the last thing studied. In all cases the national character appears to stamp itself on machinery of every kind.

I have treated the modern locomotive from three points of view, namely, as a vehicle, as a steam generator, and as a steam engine. A certain amount of overlapping is unavoidable, but it will not confuse the issues.

I am deeply indebted to old friends and acquaintances for valuable assistance. I have only had to ask for drawings and information to obtain them. Among others, I must mention Mr. J. A. Aspinall, General Manager, Lancashire and Yorkshire Railway; Mr. G. Churchward, Great Western; Mr. Dugald Drummond, London and South Western; Mr. J. Holden, Great Eastern; Mr. G. Hughes, Lancashire and Yorkshire; Mr. Ivatt, Great Northern; Mr. Wainwright, S. E. and C. Railway; Mr. G. Whale, London and North Western; and Mr. Theodore N. Ely, Chief of Motor Power, Pennsylvania Railroad.

I have not attempted to quote all the books, British and foreign, and papers read before such bodies as the Institution of Civil Engineers, or Institution of Mechanical Engineers, which have helped me; but I have given at the end of this volume a short list of the names of works which can be studied with advantage by those who wish to know more about the locomotive engine.

Finally, I may say that in writing I have carefully kept in view the needs of the student. I have endeavoured to make the study of the locomotive attractive. Unfortunately, it lends itself in many ways to mathematical treatment; and, the mathematics of the locomotive are very far from being a good introduction to its study. It may be added that in practice they play but a secondary part; and this principally because they do not always fit in with existing conditions. Anyone who has the chance of standing on the running board of an express engine moving at fifty or sixty miles an hour, and watching the behaviour of the valve gear, will understand just what I mean.

I have endeavoured, as I have said, to tell my readers what the modern locomotive is and why it is what it is. For this purpose, I have only required a comparatively small number of diagrams, and I have not illustrated any types of locomotive. Photographs will be found of these by the hundred in other volumes, where they serve a good purpose no doubt. They would be superfluities in this book.

VAUGHAN PENDRED.





THE RAILWAY LOCOMOTIVE

SECTION I

THE LOCOMOTIVE ENGINE AS A VEHICLE ¹

CHAPTER I

FRAMES

No characteristic of the locomotive possesses so much importance for the travelling public as its performance as a vehicle. By far the larger proportion of the serious, or even terrible, accidents which occur in the present day on railways in this country are derailments.² The train runs off the track, and is more or less smashed up according as the speed is high or moderate. It is certain that in nearly all cases it is the locomotive that first leaves the line; carriages are occasionally derailed,

¹ The locomotive was first dealt with as a vehicle by the late D. K. Clark, in "Railway Machinery," published in 1855.

² Among the more recent may be mentioned the derailment of a Great Western express near Loughor, South Wales, on October 3rd, 1904, 5 killed and about 50 injured; on December 23rd in the same year a Great Central train was derailed at Aylesbury, 4 killed and 4 injured; January 19th, 1905, Midland train derailed near Cudworth, 8 killed and 20 injured; September 1st, 1905, train derailed at Witham Junction on the Great Eastern, 11 killed and 40 injured; July 1st, 1906, American boat train wrecked at Salisbury, South Western Railway engine upset on a curve, 28 killed and 12 injured; and October 15th, 1907, London and North Western train derailed on a curve at Shrewsbury, 18 killed and many injured.

but the fact that each is tied by the draw-bar to the coach next in front and next behind it tends powerfully to prevent the escape of the wheels from the rails. Indeed, there are well-known instances in which a pair or more of wheels have left the track, run for a while on the sleepers, and then been pulled back to the rails and continued running very little the worse. No one has ever heard of an engine getting off the road and on again automatically. Furthermore, if an engine runs badly, it may break rails and injure the road in various ways, as will be explained further on. A bad road is an unsafe road, and so, although the engine's defects may not be those which induce derailments directly, they may be exceedingly mischievous in other respects.

The locomotive is subjected to two classes of disturbance, the one external to it, the other internal. The object of the designer is to combat or get rid of both, and as we proceed it will become evident that the task is by no means easy to perform.

It must be steadily kept in mind that the locomotive and the permanent way are but two parts of the same machine. The rails bear precisely the same relation to the engine that the V grooves of a planing machine do to the sliding table. Good planing cannot be done unless the grooves and slides are in order; and smooth, safe travelling is impossible unless the engine and the road are both in excellent condition, and in as nearly as may be perfect mechanical adjustment. If the road is bad, uneven, and weak, the disturbing effects may be so great as to mask defects in the engine. On the other hand, the road may be so excellent that the inherent defects of the engine may be forced into prominence, the internal factors of disturbance then masking such defects in the track as may still exist.

Let us deal with the external disturbing forces first.

If the track was dead straight and absolutely smooth, level and rigid; if the wheels were quite cylindrical and carefully balanced, then a vehicle might be run at any speed without the least danger. No force would solicit it to jump off the rails or overturn. These conditions represent the maximum limit of

safety. Just in so much as these conditions remain unfulfilled will the probability of derailment or upsetting be augmented. In practice the maximum limit can never be attained. The rails are never wholly smooth, level, and unyielding, and any vehicle intended to run on them with safety must be provided with expedients by which the effect of the imperfections in the track on the stability of the machine will be minimised. The influence of imperfections may be divided into two sections, one vertical, the other horizontal. Thus the rails not being dead level, the wheels have to run up and down so many steel waves more or less long and seldom coincident on both rails. To reduce the jumping motion springs are placed between the axle boxes and the body of the vehicle. To neutralise the effect of horizontal imperfections a certain amount of lateral flexibility is imparted to the vehicle. Curves may be regarded as horizontal defects in the permanent way; and to help the locomotive to deal with the centrifugal effort the outer rail is raised above the level of the inside rail by an amount fixed by the radius of the curve and the speed at which it is traversed. These are general principles; we may now proceed to consider them in more detail.

Every locomotive consists of a framework or *chassis* supported by springs on wheels. The framework carries in its turn a boiler, and an engine with two, three, or four horizontal or nearly horizontal cylinders, two being the usual number. The framing may be regarded as the link between all the various parts of the whole locomotive. There are two types of framing, namely, the plate frame and the bar frame. The latter is very little used in this country; the former very little used in the United States. In certain cases it is not easy to say to which type the framing belongs; but these are very exceptional.

The plate frame is a rectangular steel structure, composed mainly of two plates extending from the leading to the trailing end of the engine. Their depth and thickness vary in different designs; but it may be taken generally that the plates are 1 inch to $1\frac{1}{4}$ inch thick, and 18 inches to 2 feet deep. They are secured to each other by cross plates and angle steels. These main frames are usually supplemented by secondary frame plates much

lighter and narrower, on top of which rests a flat steel plate, known as the "running board," along which the driver can walk, and so oil and inspect his engine while it is running. Little or nothing of the main frame can be seen in many engines, because it is concealed by the wheels, splashers, running board, &c.

It is of the utmost importance to the good and safe running of the engine that the framework shall always remain quite rigid; that the angles between the longitudinal and the cross plates shall be true right angles; and that, in a word, no twisting in any plane shall take place. If the track were a dead level there would be no risk of twisting; but it is not level, and one corner of the engine may be raised by a wheel on a ridge, while another is lowered because the nearest wheel is in a hollow. Changes in the amount and direction of the stress occur every moment. The stresses are far too complicated to permit of mathematical treatment. The designer never attempts to calculate their amounts. He adapts the proportions, and method of riveting or bolting, which have been found by experience to be the best. Any considerable change in design involves something of an experiment. Risks are got over, however, by the simple expedient of making things very strong.

Frames may be either "inside" or "outside." In the first case the journals of the axles are inside the wheels. In the latter case they are outside the wheels. The distance between the bosses or hubs of the wheels cannot for a line of 4 feet 8½ inches gauge be more than 4 feet 5½ inches, and with inside cranks this reduces the length of the bearing or journal within narrow limits. If the journals are placed outside, then the bearing can, of course, be made as long within reasonable limits as may be desired; the load per square inch is reduced, and a substantial advantage gained. But the cross breaking stress on the crank axle is augmented; and besides, with coupled engines, cranks fitted on the ends of the axles become necessary, and the design of the engine ceases to be compact. With inside frames no crank arms are used, the pins being secured in radial prolongations of the wheel bosses.

So long as engines remained small, and particularly with

single engines, either the outside bearing or a combination of the outside and inside bearings remained in favour. The combination was in a way a compromise. Two short journals were used, one inside, the other outside the wheel, which was then so far supported that even if the axle broke anywhere but in a journal the wheel could still carry its load, and the engine would not be derailed. The advent of the big coupled engine, however,

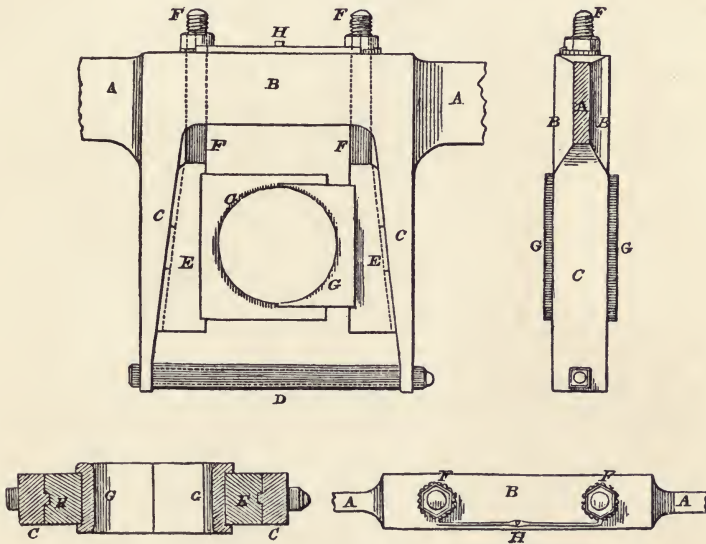

FIG. 1.—Stephenson inside axle box.

gave the *coup de grace* to outside bearings, and they are very seldom seen now except on old locomotives. But from the first there was trouble. The crank axles of those days were not very trustworthy forgings, and as far back as 1838 we find Robert Stephenson putting in no fewer than four inside frames, which were thus described by Mr. W. N. Marshall many years ago. This description and the illustrations, Fig. 1, are worth producing, because the inside frame to sustain the crank shaft against the thrust and pull of the connecting-rod is still used. The axle box also shows the system of wedges for tightening the

bearings on the shaft, and also in the horn-plates. All driving axle boxes are fitted with wedges to take up wear between the axle boxes and the faces of the horn-plates, but only a single wedge is used, as the small longitudinal displacement cannot affect the running of the engine.

“Four wrought iron frames A A, $3\frac{1}{2}$ inches deep and $\frac{3}{4}$ inch thick, are fixed between the smoke-box and the fire-box to afford additional strength to the engine by securing firmly the back plate of the smoke-box in which the cylinders are fixed, and which has to bear the whole strain of the working of the engine. These inside frames have also bearings in them for the cranked axle, and hold it steadily against the action of the connecting rods, by which it is strained alternately in opposite directions. They are attached to the smoke-box by means of T-shaped pieces of iron, which are riveted on to the inner and side plates, and are bolted to the ends of the frame. The two middle frames are made to approach each other, and are welded together at the back end, so that there are only three bearings on the cranked axle. The inside bearings shown in Fig. 1 are formed by thickening the frame plate A to $2\frac{1}{2}$ inches at B. It is made into two inclined limbs C C, and between which are placed the two bearings G G, by which the axle is embraced. These are tightened and adjusted by means of wedges E E, taken up by screws and nuts F F. The lower ends of C C are united by a tube D placed between them, and a bolt and nut passed through it.”

The plate frame possesses a good deal of lateral elasticity through a small range, and this is of use. In the early days of locomotive engines, Messrs. Sharp, Roberts & Co., Atlas Works, Manchester, built hundreds of engines the side frames of which were ash planks about 3 inches thick, secured between two iron flitch plates. For the comparatively small locomotives of the period these frames were most excellent. Fig. 2 is an elevation of a standard type of engine constructed by Robert Stephenson & Co. It was closely followed in design by Sharp, Roberts & Co. The illustration is given here because the general features of the design were copied for many years, and the arrangement of the springs is used to this day. A few engines are

still running with them ; indeed, at one period the ash side frame was in extensive use. In the present day, however, only the plate and the bar frame are used. This last was introduced by Mr. Bury, of the firm of Bury, Curtis & Kennedy, about the year 1833. As its name denotes, it is built up of a number of rectangular bars, either welded together or secured to each other with rivets, dovetails, and, in most cases, bolts. These

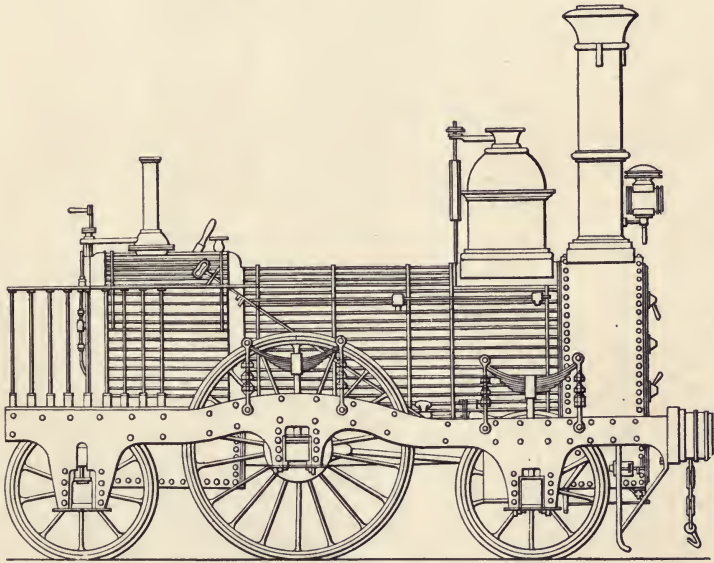
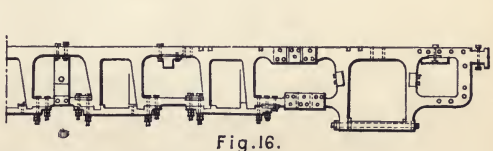
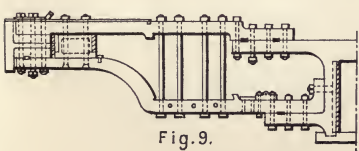
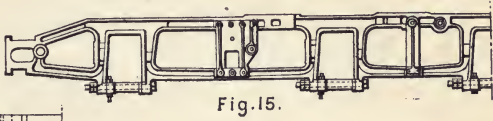
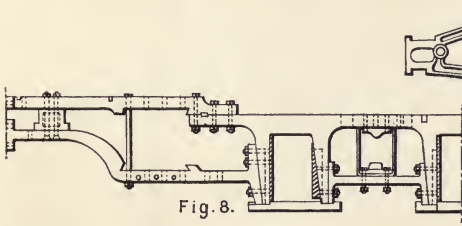
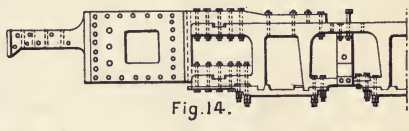
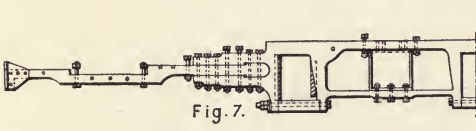
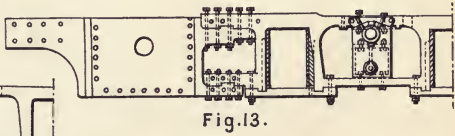
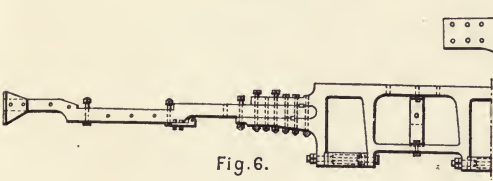
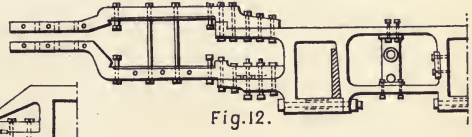
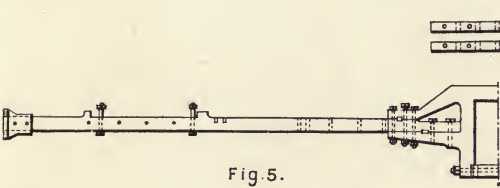
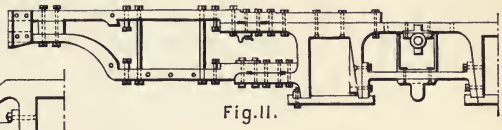
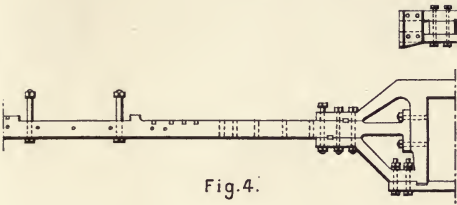
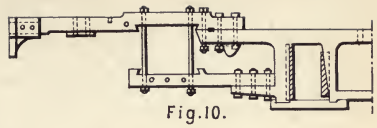
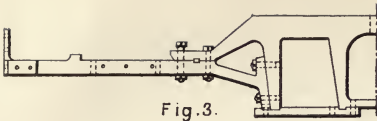

FIG. 2.—Stephenson standard locomotive, 1838.

last are turned dead true, and are made tight driving fits for the holes into which they are put. In the early days the United States possessed no rolling-mills which could make plates fit for side frames. The average smith possessed skill enough to build up frames from bars forged under a water-driven tilt hammer. So the bar frame found favour, and although the United States can supply steel plates of any required dimensions now, the bar frame is still retained. It is a very good frame, and possesses some advantages over the plate frame, but it is expensive to

make and very costly to repair. The plate frame is so simple that its essentials and its qualifications for the work it has to do can be understood in a moment. This is far from being the case with the bar frame, and an account of some of the modifications which it has undergone is introduced here because its history sets forth almost directly the nature of the stresses to which the framing of a locomotive, no matter how constructed, is exposed, and the way in which development proceeds. For the drawings the author is indebted to the pages of the *Railroad Gazette*. In the United States the bar frame has always been made in two pieces as shown in Fig. 3, the front end carrying the cylinders and the back piece the horn blocks for the axle bearings. Bury almost invariably forged his frames in one piece, which he could easily do because the engines were small, and it must not be forgotten that when the plate frame first came into being it was made of iron in three lengths with two welds. The modern frame is a continuous plate of steel. The great trouble has always been with the joints. In Fig. 3, which explains this, is shown the arrangement used in the earlier days—say 1845. The key was supposed to save the vertical bolts some shear. While the cylinders were small this plan answered fairly well; with larger cylinders the bolts stretched and the nuts worked loose. Then came Fig. 4, with the principal bolts a hard driving fit, and in double shear. Double keys were used, but they twisted, and did not then help the bolts. This was followed by Fig. 5. Still the longitudinal alternating stresses were too much for the joint. Then came Figs. 6 and 7, all still depending on bolts.

In some designs the frames had double bars—they are called “rails” in the States—as seen in Figs. 8, 9, 10, 11, and 12. In these it is clear that bolting had been carried as far as possible, and for the more modern big engines a somewhat different method of construction has been adopted, as shown in Figs. 13 and 14. Here the two front bars or “rails” have been united in a single deep slab, to which the cylinders are bolted. The first frames made in this way had the fastening to the main frame made as in Fig. 13, but they have to some extent been superseded by the plan shown in Fig. 14.



FIGS. 3-16.--The development of the bar frame.

Seeing how unsatisfactory in certain respects the built-up bar frame has been, at least for large locomotives, it is not surprising that attempts have been made to do away with it. The United States locomotive designer is obstinately determined not to have the plate frame, and he has turned his attention to the production of cast steel frames in whole or in part. One is illustrated in Fig. 15. The back ends of the frame being spared the worst of the longitudinal stresses are very much what they always were. One is illustrated in Fig. 16. It must be understood that the engravings given here do not represent every kind of bar frame in use. It lends itself to wide diversities of treatment, and is much favoured on several European railways.

The plate frames are secured to each other by cross plates, usually four in number—that is to say, one at the trailing end, another just in front of the fire-box, the leading head stock carrying the front buffer beam, and a very heavy, strong framework supporting the bogie. There is besides the “spectacle plate” or “motion plate,” which is a steel casting supporting the outer ends of the piston-rod guides, and the valve motion. The cylinders are in the present day usually cast in one piece, and being bolted between the frames, stiffen them still further. As has been said, the stresses to which the framing is exposed are very great. Thus, in large engines, that due to the steam effect on the pistons may reach as much as fifty tons. Then there is not only the weight of the boiler and the water in it, but the various stresses set up by the arrested momentum of the boiler when the engine lurches or rolls.

For the bar frame it is claimed that it is on the whole lighter than the plate frame, and that various parts may be more conveniently secured to it, while it gives unexampled facilities for access to the mechanism. But it has been found essential to stiffen it by plates bolted to the frame and to the boiler, a practice which has been almost given up in this country, as grooving is very likely to take place where the stiffening plate is riveted to the boiler shell. This grooving is the result of minute bendings backward and forward of the boiler plate just where the frame plate is riveted to it.

The frame has to be fitted with wheels and springs. The axles revolve in boxes, either made entirely of gun metal or of pressed steel lined with brass or gun metal. The practice of making axle boxes of cast iron has long since been given up. At one time they were forged under a steam hammer; but about 1872 the late Mr. John Haswell, locomotive superintendent of the Austrian State Railways, invented and constructed a very powerful hydraulic forging press in which axle boxes, cross heads, and such like were pressed out of white hot steel billets, at the rate of about half a minute for each. An axle box is shown diagrammatically in Fig. 17.

To the plate frames are bolted steel castings or forgings called horn plates, in which the axle boxes can move up and down through a range in Great Britain usually of about 2 inches, in France, often of nearly twice as much, the springs being longer and more flexible than in Great Britain. When plate springs are used, they either rest

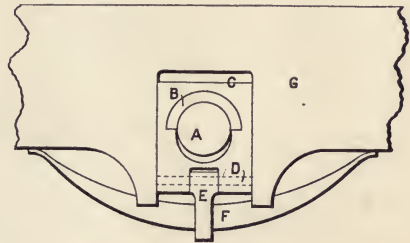

FIG. 17.—Axle-box.

directly or through the medium of struts on the tops of the axle boxes as shown in Fig. 2. In some cases, however, the springs are placed under the axle boxes and secured to them by links, as in Fig. 17. Here A is the axle, B brass, C axle box, F the spring, the ends of which are supposed to rest on rubbing plates under the frame. The spring is coupled to the axle box by the links E and the pin D. An example of the overhead spring is given in Fig. 2. Coiled springs are favoured, because they save space. They are invariably worked in compression.

In the United States almost always, in this country frequently, the ends of springs are coupled to each other by what are known as balance beams or compensating levers. An example is shown in Fig. 18, which illustrates a portion of an American bar frame locomotive. A is a compensating lever; at C is seen the end of another lever. In this way stresses are eased, and

the engine runs more smoothly. For let it be supposed that each spring works by itself, and has no connection with its fellow; then it is easily understood that when a wheel is passing over the summit of a wave in the rail, a large part of the load will be taken off a neighbouring wheel in a hollow, and a corresponding stress will be thrown on the whole frame, &c. If, however, the ends of the springs are coupled by a balance beam, then a portion of the extra load on the first spring will be transferred to the second, and the engine will run with more flexibility. The risk of breaking springs or axle boxes is besides much

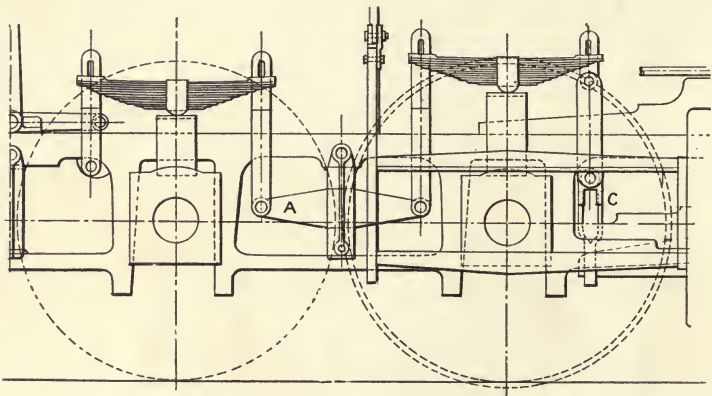

FIG. 18.—Compensating lever.

reduced. Many engineers in this country hold, however, that on a first-class road balance beams are quite unnecessary; and, by imparting too much resilience to the engine as a vehicle, tend to promote rolling and pitching, and even to make it unsafe at high speeds. When, however, an engine encounters a steep incline which does not “melt into the level” as it ought to do, the leading springs may have so much extra load thrown on them that they will break. Again, in running off the incline on to the level again an extra load may be thrown on the driving wheel springs. The evil has in some cases been so pronounced that the road has been improved by modulating the incline at the instance of the locomotive superintendent.

So far only vertical stresses have been considered, and the vehicle has been supposed to traverse only a dead straight road. We have now to regard it from another aspect. Railways abound in curves, and these have to be traversed at various speeds, sometimes very high.

The smallest locomotives, such as are used by contractors on civil engineering works, alone have four wheels and no more. Until a comparatively recent period all but exceptional engines were carried on six wheels. The practice then arose of carrying the leading ends on a four-wheeled bogie, and this gave eight wheels. A further increase in length brought in a fifth pair under the footplate. An addition in size gave six coupled driving wheels instead of four. The practice has recently grown up of indicating the number of wheels thus: 2—4—2, which means 2 leading, 4 driving, and 2 trailing wheels. Again, 4—2—2 means a 4-wheeled bogie, 2 driving wheels and 2 trailing wheels, and so on. In goods engines as many as twelve coupled wheels are used, for the most part in the United States, where at certain seasons of the year trains carrying as much as 2,500 to 3,000 tons of grain are hauled at speeds of ten or twelve miles an hour from eastern corn lands to western seaports.

The so-called wheel base of a locomotive is the distance from the centre of the leading to the centre of the trailing axle; the wheels are all firmly secured on the axles by forcing them on by hydraulic pressure, so that they must turn together. The end-wise play of the axles in their bearings, and of the boxes in the horn plates, is but a fraction of an inch. When the engine stands on a curve, in order that all the wheels may fit it the frame ought to bend to the same radius as the curve. This is impossible, yet it would also be a mechanical impossibility for a rigid vehicle with six wheels to get round a rigid curve if the flanges of the wheels fitted the rails closely. The difficulty is overcome in various ways. In the first place the rails are always about half an inch wider apart than the distance between the flanges. This distance is increased to about an inch on sharp curves. Secondly, one or more pairs of wheels about the mid-length of the engine are sometimes made "blind," that is to say,

they are without flanges. Thirdly, one or more of the axles are provided with boxes which can slide right or left in the horn plates, a couple of inches each way. They are kept normally central by strong coiled springs; and lastly, there is the bogie.

Any reader interested is advised to set out a curve on a drawing-board and set out a vehicle on it. He will see that no matter how many wheels the vehicle has, it will do its best to arrange itself as a chord to the arc. Now a four-wheeled vehicle can always do this without trouble, and the axles will approximate in position to radii of the curve. In this country it may be taken that the minimum radius of curves traversed at any but the very slowest speed is about 6 chains, or say 400 feet. Let our four-wheeled vehicle be a bogie with a wheel base of 6 feet; it will be seen that to all intents and purposes both axles are radii to the curve, with an approximation to the truth so close that the difference must be measured by small fractions of an inch. Such a curve, therefore, could be traversed by the bogie almost as easily as if the track were straight. If now we take an engine with four wheels coupled near one end, and support the other end on a bogie, all the axles will virtually radiate to the centre of the curve. But a horizontal centre line drawn through either a pair of coupled wheels or a pair of bogie wheels will be a tangent to the curve, as the engine frames extend for several feet in advance of the leading pair of driving wheels, and, being a tangent to the curve, it follows that a central line prolonged along this tangent cannot fall on the centre of the bogie, but at some place outside it. Thus to get the best results the whole bogie must be able to move inwards, or, what comes to the same thing, the engine frame must be permitted to retain its tangential position while rounding the curve.

CHAPTER II

BOGIES

At first sight the bogie appears to be a very simple thing whose action can readily be understood. In point of fact, however, this is not the case, and the bogie plays so important a part in the present day that both the theory of it and practice with it

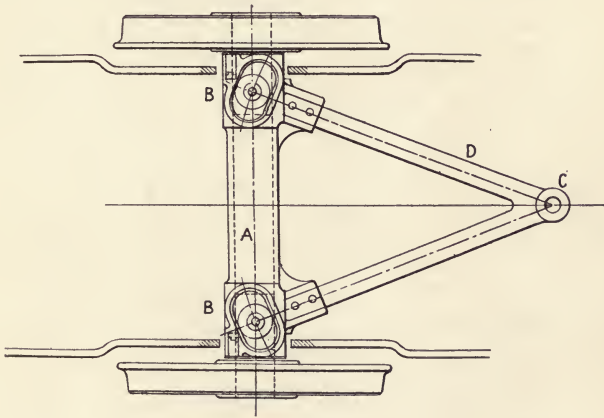
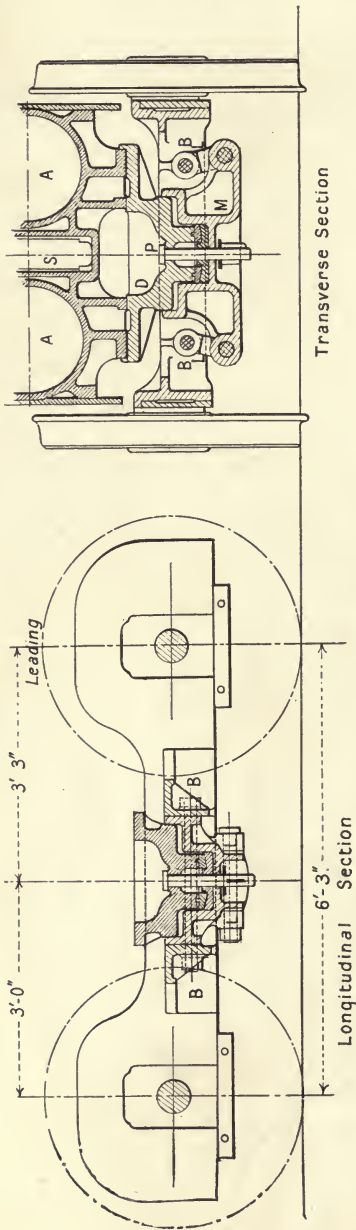

FIG. 19.—Bissell bogie.

deserve very careful consideration. It originated in the United States. It is claimed for it that it was an English invention, because small four-wheeled coal mine trucks were called "bogies." But in the United States what we term "bogies" always were and are still called "trucks." The first railways made in America were very bad indeed, much worse than English railways, and the four-wheeled locomotives were continually running off the road, particularly on curves. It was decided then to copy



Figs. 20 and 21.—Great Northern swing link bogie.

the ordinary horse-drawn vehicle and fit locomotives with a species of fore carriage. For convenience this was made at first with four wheels, while the engine proper had but two. No traversing gear was required, because the leading end of the engine could follow the bogie round the curve. After a time it was found that coupled wheels were necessary. Traversing then became essential, and Mr. Bissell, an American engineer, invented the "Bissell truck," which had two wheels while the locomotive had four. His was a very clever device much used at one time in the United States, and still enjoying favour there. The accompanying diagram, Fig. 19, will tell the reader almost at a glance what it is. It is a plan of an improved "pony" used on the Great Northern Railway. As first used the pony had, as stated above, but one pair of wheels. Afterwards four wheels were employed and it ceased to be a pony. In this country it was fitted to all the locomotives

designed by the late Sir John Fowler for the Metropolitan Railway. We have only to substitute a bogie with four wheels for the single pair in Fig. 19, and the description will apply. A frame A enclosed the axle; to the back end of the frame was bolted a heavy flat bar triangle or tail D; through the eye on the end of this passed a bolt C; and round this bolt as a pivot the truck could describe an arc, swaying to the right and left. It was essential, however, that it should always tend to keep in the centre line of the engine. To ensure this, the axle casing was fitted at the forward end with flat transverse plates provided with inclined planes. The cross beam under the engine was fitted with similar planes B which rested on those first named.¹ Whenever the bogie moved to the right or the left it had to lift the leading end of the engine, which, tending to slide down the inclined planes, always returned the truck to its normal position as soon as the locomotive, having passed over the curve, entered the straight again. In the United States a somewhat different arrangement is in use. The leading end of the engine is hung by links from the bogie, which virtually shorten, as the engine moves to left or right, in a way quite obvious. The modern bogie is only a modification of the original. Figs. 20 and 21 show a bogie on the Great Northern Railway fitted with swing links.

A A are the cylinders, S the valve chest. The cylinders, and with them the leading end of the engine, rest on a heavy casting D circular in plan to allow the bogie to turn round the pin P. This iron casting rests in turn on one of steel M. This casting has no power of traversing—it may be regarded as part and parcel of the engine. B B shows one of two cross beams. The entire weight of the leading end of the engine is supported by four links L L, and will always tend to return to the position shown, just as a pendulum seeks its lowest position. Traversing is obtained very simply in this way. A saucer-shaped steel plate is pinned on the bottom of the upper casting, and a

¹ In the Great Northern pony, the spring pedestals rest directly on the tops of the axle boxes E. The circles show the enlarged ends of the pedestals made of brass to reduce friction.

similar plate is laid under it in M. This permits the bogie to rock. One corner may rise while another falls, in a way that will be explained further on.

It is desirable that the reader should clearly understand what a complete bogie is like, which it is not easy to do from sectional drawings. To this end Figs. 23 and 24 are given. The bogie frame is usually a built-up structure like an engine frame. If, however, it could be produced with a less number of riveted and bolted joints a substantial advantage would be gained. The Leeds Forge Company, Limited, has for years turned out great quantities of flanged furnaces, &c., the flanging being done by an hydraulic press in a way which will be understood from the annexed diagram (Fig. 22).

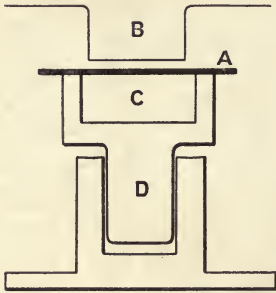

FIG. 22.—Flanging press.

Here A is the plate to be bent, let us suppose, to the shape of the lid of a pill box. C is the hollow top of a hydraulic press of which D is the ram. B is a fixed circular block, just as much smaller all round than C as the plate is thick. The flat circular plate is heated to a dull red heat and placed as shown.

Then the ram is pumped up, and the plate is forced into C, curling up all round the edges without crumpling or buckling. Of course a trough could be made in the same way by using a long mould and several hydraulic rams. The system is in use all over the world; but certain firms make a speciality of pressed work. The Leeds Forge Company includes bogies of all kinds. Figs. 23 and 24 illustrate two standard wagon bogies made of pressed steel. Fig. 23 is an open-ended bogie; the sides are united by the cross beams near the middle. On the top of these is bolted a casting with a circular boss. A similar boss is bolted under the wagon body, which rests on it, a pin being dropped through both round which the bogie swivels. As there is a bogie at each end of the wagon no traversing motion is required. On each side frame are seen bearing blocks on which a part of the weight is carried. The axle boxes and the coiled springs in compression

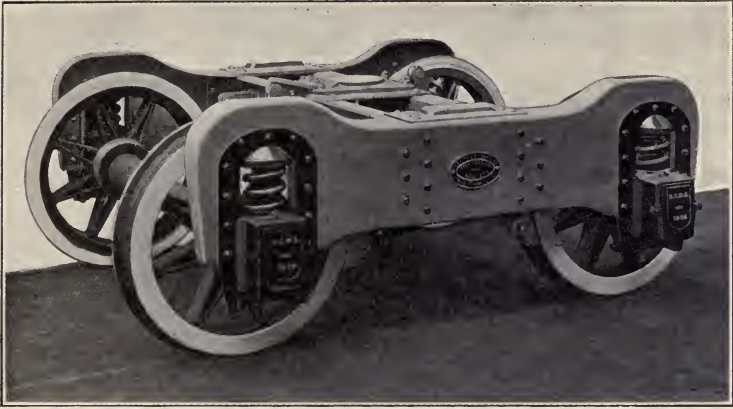

FIG. 23.—Open end bogie.

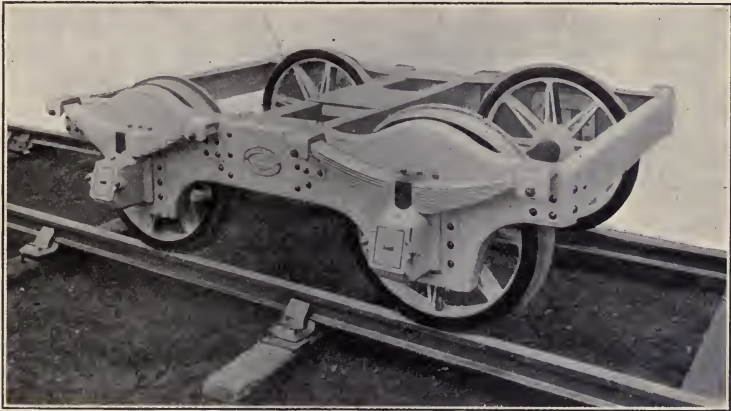

FIG. 24.—Closed end bogie.

which transmit the load to them and the horn plates are all very clearly shown. Fig. 24 is a wagon bogie with closed ends and leaf instead of coiled springs. It is not fitted with brakes; the open-ended bogie, Fig. 23, is. The hinged hanger gear for them can be seen bolted to the cross beams. An enormous number of

pressed steel bogies is in use; the Leeds Forge Company alone has made 15,000 of them.

Figs. 25, 26, and 27 illustrate a standard engine bogie designed by Mr. James Holden, locomotive superintendent of the Great Eastern Railway. Traverse is controlled, not by metallic springs,

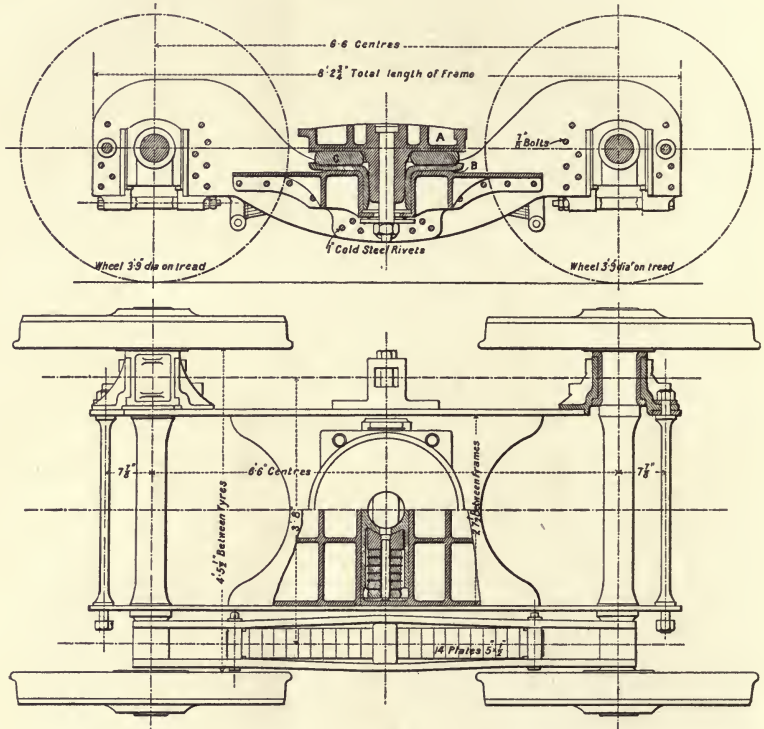

FIG. 25.—Standard bogie, Great Eastern Railway.

but by indiarubber discs, which Mr. Holden prefers because they deaden the shock when an engine takes a curve. Engines fitted in this way ride very easily. Sliding takes place on the surface B. There is a cushion of indiarubber, C, between A and the sliding portion above the top of the surface B. The amount

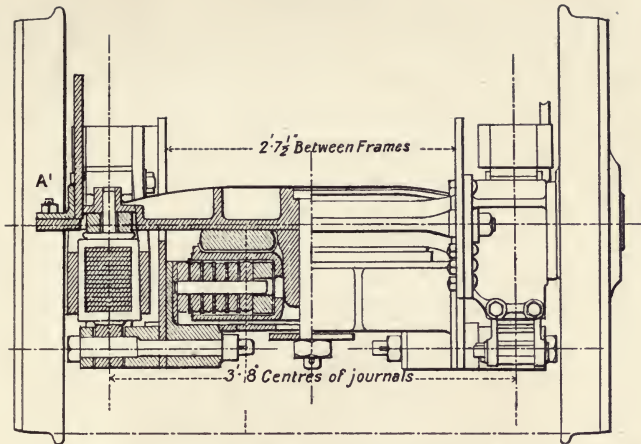

FIG. 26.—Standard bogie, Great Eastern Railway.

of traverse is $1\frac{1}{2}$ inches. The slide is controlled by the six india-rubber pads shown in the sections. The casting A is bolted

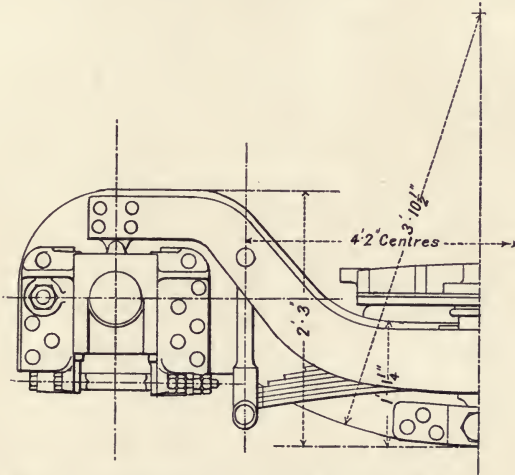

FIG. 27.—Details bogie, Great Eastern Railway.

to the main frame, A¹ being one of the bolts used for this purpose.

On the Great Western Railway Mr. Churchward uses a bogie

which is a modification of Mr. Ivatt's on the Great Northern. Swing links are employed to give traverse. Fig. 28 illustrates this bogie as fitted to Mr. Churchward's latest design, the four-cylinder simple engines of the Star class working the heavy long-run West of England express. A strong casting A, closely resembling an old Greek seat or stool, with four curved legs, of which two are shown by B B, is bolted to the front end of the engine and drops down between the bogie frames. Four links C unite A with the bogie. So far we have the ordinary swing link. The difference lies in the use of double suspension pins D D,

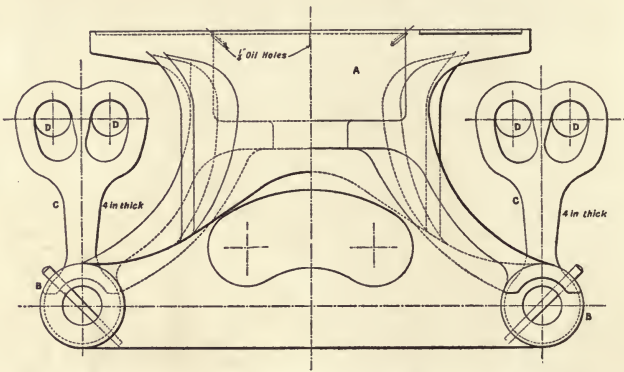

FIG. 28.—Swing link bogie, Great Western Railway.

one in each of the elongated holes. On the straight the engine is carried on both pins. When a curve is taken the lower end of C is swung on a curve to the right or left. The link then leaves one pin and is carried only by the other. The condition is then one of unstable equilibrium, and the front end of the engine being raised it tends to fall and restore the link to a bearing on both pins D D. The Great Western bogie is fitted with the vacuum brake, the mechanism for which crowds all the available space, and this arrangement is found more convenient than the two inclined links of the Great Northern. The pins D D run fore and aft between two cross beams uniting the two side frames of the bogie.

Three typical bogies have now been illustrated. Those used on other railways only differ from these in details, as, for example, the use of coiled or leaf traverse springs instead of indiarubber pads.

Reference must be made here to a very noteworthy express locomotive designed by the late Patrick Stirling while locomotive superintendent of the Great Northern Railway, about 1872, which represented an exception. A number of engines built to this design carried on the express traffic of the line for several years with the utmost success, until, indeed, they were overcome by the increasing weight of the trains which they were called upon to haul. They had "single" driving wheels—that is, only one pair—8 feet 1 inch in diameter, with new tires, and outside cylinders 18 inches diameter by 28 inches stroke—at the time probably the largest locomotive cylinders in the world, certainly the largest in Great Britain. A pair of trailing wheels 4 feet 1 inch in diameter was placed under the footplate. The leading end of the engine was carried on a four-wheeled bogie, with wheels 3 feet 11 inches in diameter and 6 feet 6 inches between the axles. This bogie was altogether remarkable and excellent. It had no traversing arrangement; no springs to restore it to the normal; no complications of any kind, and yet it did, up to a certain point, all that the most complex bogie can do. It swivelled on a pin like other bogies, but this pin was not put in the centre of its length, but 6 inches nearer to the hind than the front axle. If the pin had been placed in the centre of the length of the bogie then the leading wheels could not follow the curve, because the leading end of the engine would pull the whole bogie outward. As, however, the pin was placed far back, then the centre point in the length of the bogie could move inwards, which is precisely what the traversing gear already described is intended to permit, and the moment the curve had been traversed the bogie would automatically set itself normal to the road. For very sharp curves the amount of traverse which can be had in this way is, however, not sufficient, but on the Great Northern these engines ran with a minimum of resistance. D. K. Clark, writing of them, says: "The bogie leads better in having the

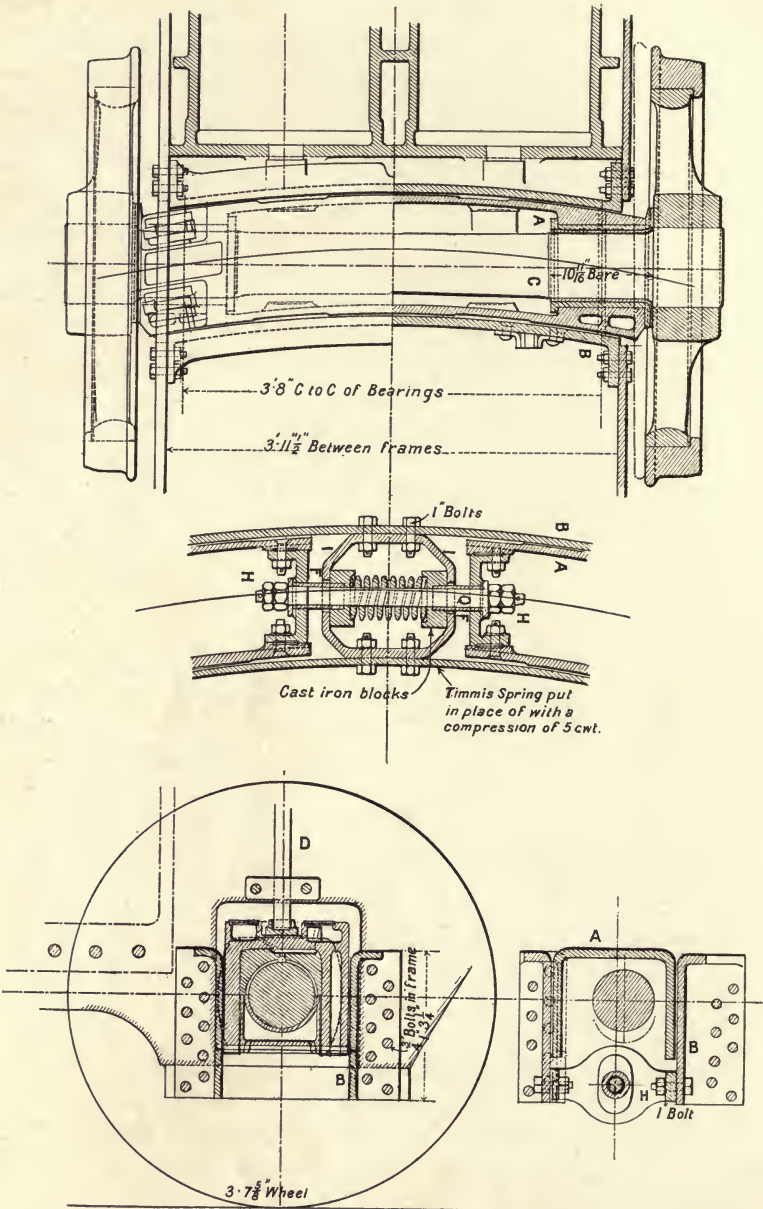

FIG. 29.—Traversing leading axle, Lancashire and Yorkshire Railway.

leading wheels better in advance than if the pivot were equidistant between the axles. Not only do the leading wheels turn to the curve with greater facility, but the hind bogie wheels make less transversal movement towards the outer rail, and in so much the guiding of the engine is eased."

The place of the bogie is in some cases taken by the traversing axle box, which has assumed several forms. One of the best was that invented by the late W. Bridges Adams, and successfully used on many railways, among others the London, Chatham and

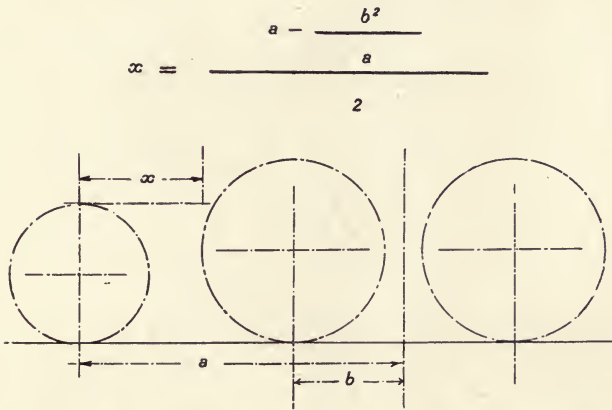

FIG. 30.—Mr. Baldry's rule for finding the centre from which to strike the curve of a radial axle box.

Dover, and the Metropolitan extension. Fig. 29 illustrates a traversing leading axle as used now on the Lancashire and Yorkshire Railway. The axle C is enclosed in a curved casing or inverted trough A, which carries at each end the axle box. The spring strut is shown by D. Its lower end drops into a brass foot or pedestal which rests on the flat top of the axle box, which moves under it as the engine takes a curve. A is in the same way enclosed in a trough B, which is part of the cross framing of the engine under the smoke box. Suitable guiding faces are provided on and in the two troughs; consequently the leading wheels can move freely right and left in a curve the length of the radius of which is that of the curve of B. To regulate and

control the amount of the traverse, and to supply the necessary effort required, as just explained, to get the engine round a curve, a species of box E is fitted on the lower part of B, so as to clear the axle. In this is placed a coiled spring. Through the spring is passed a bolt G, the ends of which are secured, as shown, to cross heads H H bolted, as shown, to A. Cast iron blocks are placed at each end of the coiled spring, and on these it bears. Brass ferrules F F are interposed at each end, between the cast iron block and the cross head. The spring is put in with some initial compression. If now the axle traverses, the ferrule at one end will be pushed in with the cast iron block away from I, and the coiled spring will be compressed. Of course the same thing occurs in reverse order if the curve is reversed. This arrangement is typical of many others—in all the principle is the same, the difference is in details. The rule for finding the centre from which the curve of the axle casing is struck is given by Mr. Baldry; x is the length of the radius wanted. The diagram, Fig. 30, explains itself.

CHAPTER III

THE ACTION OF THE BOGIE

LEAVING now the construction of the bogie, let us consider what it does, how it behaves on the road, its merits and demerits.

In theory the bogie facilitates the movement of an engine round a curve. The entire weight of the leading end of the engine is distributed over four wheels instead of two, and the bogie's action is to consolidate the track by sending the sleepers down to their bearings on the ballast in advance of the driving wheels. All this is meritorious to a very high degree; and it has been plainly stated that the bogie greatly reduces the chance of derailment, and indeed enables curves to be traversed which without its aid would be quite inadmissible. So long as speeds are moderate all these propositions may be accepted as true.

It is, however, a fact worth notice that in former years derailments seldom occurred with serious results. The cause of them was almost invariably obvious. A rail was broken or the ballast was defective, or points were wrongly set. The worst accidents were collisions. In the present day the worst accidents are due to derailment, and in notable instances no satisfactory explanation has been forthcoming to account for the engine leaving the rails. There are large numbers of locomotives still running which have not bogies; they appear to be exempt from mysterious derailment.¹ Under the circumstances it is not unfair to say that the

¹ It is right to say here that many engineers maintain that there are no such things as mysterious derailments, and that in far the greater number of cases when an engine leaves the rails the fault lies in the permanent way and not in the engine. The whole subject is dealt with statistically further on.

excellence of the bogie is open to question. We shall see presently, when we come to consider the internal disturbing forces of a locomotive, how these affect the bogie. For the moment we must confine our attention to the external forces. We have seen that these are of two kinds, vertical and horizontal. Of course it is obvious that various combinations of both can take place. The first is due to the absence of uniform level in the rails. However carefully the platelayer may attend to packing up the sleepers, the road always sinks under the tread of an engine, and rises again when it has passed; the amount of sinking is a variable quantity. Again, the rails spring between the sleepers under the tread of the engine. The rail tables are not dead true. The result of all this is that, as has already been said, the locomotive continually moves on a road full of waves of varying altitudes and lengths. It is true that they are very small waves. It is none the less certain that they make themselves felt—how much felt the traveller in a luxurious carriage little knows. A full appreciation of the good and bad qualities of the permanent way of any railway can only be got by standing on the footplate of a locomotive for a couple of hours while it runs at various speeds.

In by far the larger number of locomotives the entire weight of the leading end of the engine, say sixteen tons, is carried on a bolster crossing the bogie frame, in such a way that it acts at the centre of the bogie frame only. Each of the four corners of the bogie will represent four tons, and that—less the weight of the wheels and springs—is the weight pressing down each axle box on the journal. This load is transmitted outwards from the fore and aft centre line of the locomotive. There is nothing whatever, so far, to prevent any one corner of the bogie from rising or falling. If the right-hand leading wheel goes down half an inch, the centre of the leading end of the engine bearing on the bogie bolster would fall half as much, and so on. The behaviour of a four-wheeled bogie on the road is very interesting. As fitted to passenger coaches nothing is easier than to watch it when two suburban trains run side by side. As a rule a leafed spring is fitted over each axle box. It will be seen, however, that



these springs never bend. The bogie is continually on the jump as a whole, wheels and all, but it plays about the centre pivot. The axle-box springs are of no use; and, indeed, some bogies are made without them, elasticity being obtained by the springs between the cross bolsters of the carriage frame and the bogie near the centre. It has never been disputed that the ease with which all the four wheels take the same load and transmit it to the rail is an excellent thing. Bogies relieve the stress on the permanent way, and for that reason are in favour with the civil engineering staff of railways; but it will not do to forget that this very freedom of motion may be a direct source of danger. It will not do to leave the leading end of the engine to wander from side to side. The bogie itself, too, is liable to "get across the road." Its wheel base is short, and unless special precautions are taken it may "wobble"—there is no better word—as it runs, and the wobbling may throw the flanges of the wheels to the right and left alternately with such violence that the wheel may escape from the rails. Many engineers, therefore, insist that the wheel base of a four-wheeled bogie shall be made at least half as long again as the gauge is wide. In this country and in the United States 6 feet is a very usual wheel base, but on the Continent, and notably in Austria, a wheel base of as much as 9 feet is favoured.

It is right at this point to bring a fact into prominence which is frequently overlooked—it is that all the principal parts of a locomotive possess a great deal of mass; in popular phrase, they are very heavy. Mass is the complement of momentum, and the stresses set up in starting and stopping motion are correspondingly severe. Thus, if from any cause, such as crossing points, &c., the leading or trailing end of a bogie is violently flung right or left, although the distance traversed may not exceed three-quarters of an inch, yet there will be quite momentum enough to cause a jerk and a recoil, and it may easily happen that a very free and easy bogie may give a very unsteady, lurching engine at high speed.

Hitherto we have been considering the behaviour of a bogie on a straight line. We have now to consider the behaviour of the

bogie on a curve, a thing of the utmost interest in its relation to the rest of the locomotive. The modern bogie is always, as we have seen, permitted to traverse under the engine. If the bogie is quite free to traverse across the engine it is clear that it can do nothing to guide the engine round a curve. That duty would then devolve on the driving wheels, or at all events on the wheels next behind the bogie. But the bogie is never quite free. It is always returned to the central position by inclined planes, swing links, or springs shown in the illustrations. A compromise is, in short, effected between perfect freedom of traverse and absolute restraint of lateral motion; and the result is that the bogie guides the leading end of the engine round curves. To do this requires an effort, the amount of which varies as the square of the speed and the radius of curvature. In popular language, the bogie has to overcome the centrifugal force acting on the engine. Inasmuch as a good deal of confusion of thought exists about all this, even among very well informed persons, it is necessary here to go into some explanatory details.

It is an axiom of dynamics that a body moving freely in space under the action of a single force will describe a straight line. If it is to describe a curve of any order another force or forces must also act upon it. An engine traversing a curve does not want to fly outward, but to move straight on. It is not that the engine would leave the line, but that the line leaves the engine. The effort of the engine is to pursue a straight course which is always a tangent to the curve; there is no effort at radial departure made by the engine.¹

The bogie then must keep on sluing the leading end of the engine round the curve, while the trailing end is similarly worked on by the other wheels. To calculate the centrifugal effort of every portion of a locomotive on a curve would be a tedious and a profitless task. In practice the whole "mass" of the engine

¹ It is for this reason that a locomotive running at speed is never derailed radially. It runs off the line obliquely, and in many instances a derailed engine has continued its course for several yards along the sleepers quite close to the rails. This is just what might be supposed to happen if by any agency the rails were suddenly pulled away to one side from beneath the wheels.

is supposed to be concentrated at the centre of gravity, and the centrifugal stress can be determined by a very simple calculation,

$C = \frac{W V^2}{32.2 R}$. Here C is the centrifugal effort which must be over-

come to make the engine follow the curve, W is the weight of the engine, V^2 its velocity in feet per second, R the radius in feet of the curve. In other words, the effort required to keep the engine moving round the curve is equal to its weight multiplied by the square of the velocity and divided by 32.2 times the radius of the circle of which the curve forms a part.

Let us suppose that the curve has a radius of 600 feet, and that the engine is running at thirty miles an hour, or 44 feet per second, and its weight is fifty tons. Then the effort required to keep it on the rails and prevent it from flying off at a tangent will be approximately five tons. If the speed were sixty miles an hour then the necessary centripetal effort would be twenty tons, and so on. Now the effort must be distributed among the wheels, and only those whose flanges can get access to the rails can take it up. It may easily happen that the distribution is not uniform. Thus, if an engine is fitted with six wheels and a four-wheeled bogie, both the bogie-wheel flanges resting against the inner side of the outer rail will act. So will the first and last wheel of the six wheels, but the middle-wheel flange cannot touch the outer rail unless one or both of the other two are fitted with a traversing arrangement or its equivalent, such as a blind tire. It will be seen that while "blinding" tires gives freedom of motion round a curve it also augments the stress on the flanged wheels.

Although it simplifies calculations to refer the whole effort to the centre of gravity of a locomotive, really the stresses are distributed about it in a very complicated way impossible to follow as a whole. Thus, for example, we have to keep in mind that the complete engine has not only to get round the curve, but that it is also continually rotating round its own longitudinal centre of gravity. Very complicated mathematics are involved, and the result after all is fortunately not needed. The general rule to be observed is that as many wheels as possible shall act

on the outside rail to resist the tangential effort of the engine to leave the line. It is, however, often assumed that if the leading wheels radiate to the curve, the engine will follow just as a motor car does when steered to right or left; but the analogy is far from perfect, because first, in the motor car, there is only one pair of wheels to follow the lead, and the differential gear permits the outer wheel to move just as much faster than the inner wheel as corresponds to the extra distance which it has to pass over; but besides this, the motor car is subjected to centrifugal effort just as the locomotive is, and the effort may suffice to skid the car across the road, producing side slip which is the analogue of derailment.

CHAPTER IV

CENTRE OF GRAVITY

So far, although the subject has been treated as though the whole effort has been concentrated on the centre of gravity of the engine, nothing has been said concerning the position of that centre. For anything to the contrary it might be at the rail level, and the outward thrust of five tons named above might be supposed to be exerted directly on the inside of the rail. In point of fact the conditions lack this simplicity. The vertical centre of gravity is somewhere between 4 feet and 5 feet above the rails, according to the design of the engine. The centrifugal effort consequently tends not only to make the engine leave the rails, but to upset it. Overturning will take place, if at all, on the outer rail as a pivot, and complete upsetting cannot occur until a vertical line drawn through the centre of gravity falls outside the rail. Regard the triangle C E F, Fig. 31, as a solid block standing on a table. Then C represents the base, on the width of which, as compared with the height, the stability of the triangle depends.

At one period in the history of the locomotive it was held to be good to keep the centre of gravity low, because upsetting was feared; but it has long been recognised that while the chances of an engine overturning are very few, a rise in the centre of gravity confers substantial advances, which may now be considered.

In the diagram, Fig. 31, let the arrow A indicate the centrifugal effort supposed to be concentrated at the rail level. Let this effort be represented by screw jacks, A and D, laid on their sides, one for each wheel, tending to force it off the rail. The resistance to derailment will then be measured by the stress with

which the wheel presses down on the rails due to gravity¹ and it will be resisted by the chairs and keys supporting the outer rail, B.

Next let the screw jacks, as represented by the arrow D, act at a level 4 feet 6 inches above the rail; we then have, instead of a single stress, two. The first as before horizontal, and the second exerted along the inclined line E. It is easy to see that, by the ordinary laws of the composition and resolution of forces, the whole derailing effort is concentrated along the line E. The

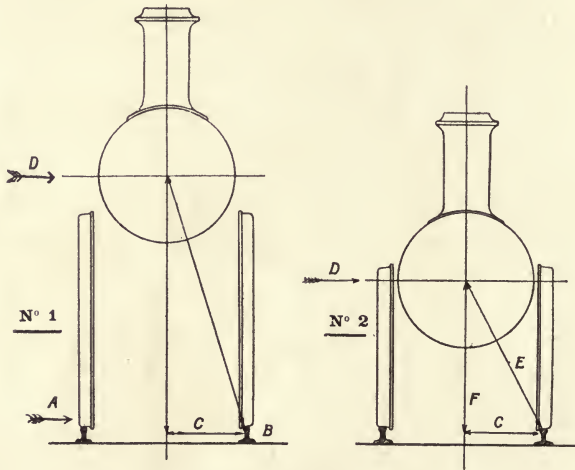

FIG. 31.—Centrifugal effort.

result is that the load on the outside wheel is much increased, that on the inside wheel much diminished. The effort to burst the track is reduced, and the resistance to derailment augmented. But it must not be forgotten that while the chances of derailment are minimised the risk of overturning is increased. Mr. John Audley Aspinall, while chief mechanical engineer of the Lancashire and Yorkshire Railway, of which line he has been general manager for some years, in the course of a report on the

¹ In the sense that the greater the weight, the greater the effort required to force the flange over the rail.

type of locomotive most suitable for high speed, presented to the International Railway Conference some ten years ago, wrote: "The oscillations of an engine with a high centre of gravity will be longer than those of a low engine. It will also ride easier, owing to the elasticity of the springs being brought more into play. This is also conducive to the reduction of side shocks and the stresses in the wheels and axles are minimised. It must not, however, be overlooked that the higher centre of gravity, when passing round a curve, causes the load on the inner rail to be diminished, and as the front end of the engine is liable at any time to be thrown violently to the inside it will have a tendency to leave the road if the super-elevation of the outer rail is excessive. The effect produced by raising the centre of gravity will be readily understood if the reader will compare No. 1 and No. 2 and the relation which C bears to E in each."

Other things being equal, the lower the centre of gravity the greater the chance of derailment due to centrifugal effort, and the less the chance of overturning, and *vice versâ*. Now in practice curves traversed on main lines at high speeds have radii so great that the chance of overturning is very small, and a high centre of gravity gives an engine which runs easily and does not stress the road sideways. The reason is that the vertical component of the centrifugal effort tends as shown to compress the outer and relax the inner springs. In other words, if the derailing effort were concentrated at the rail level, there would be no resilient resistance offered to it; but the elevation of the locus of effort bringing the springs into play eases the movement round the curve. For the mere purpose of explanation or calculation it is assumed that every portion of the engine traverses a true curve in a determinate circular path. In practice, however, this is very far from being the truth. A locomotive always gets round a curve in a series of jerks, so to speak. It is as though the permanent way represented a polygonal instead of a circular path. Why this should be, and the influence of small matters of detail in design and construction, must now be explained. To do this it is necessary

to consider the effect of an expedient universally adopted to add to the safety and improve the running of railway vehicles round curves. The outer rail is raised above the level of the inside rail, the amount of super-elevation is given by the formula $E = W \frac{V^2}{1.25 R}$. Here E is the super-elevation in inches, W the gauge in feet, V the velocity in miles per hour, and R the radius of the curve in feet. For moderate curves plate-layers work to a rule which is sufficiently exact for ordinary railway practice. They stretch a 66 feet tape as a chord of the curve, and then measure the distance between the tape and the rail at 33 feet; that distance is the super-elevation. The purpose served is precisely that with which a cyclist turning a corner or racing round a circular track inclines inwards. Racing tracks are indeed very steeply inclined when the turns are sharp. Unfortunately the super-elevation that is suitable for one speed must be too great for a lower speed, and too little for a higher speed, and that not only as the speed, but as the square of the speeds. In practice the super-elevation is "jimmered"—that is to say, a compromise is arrived at, the tendency being to make the super-elevation too great. So far nothing has been said about wheels. They will be more fully considered presently. For the moment it is enough to say that when tires are new they are slightly conical. The inclination is usually one in twenty. The object is to keep the flanges away from the road as much as possible. Let us suppose that the difference in the inner and outer diameter of a 6-foot wheel is 0.4 inch, then the circumference will be a little over 1 inch greater inside, next the flange, than outside, and the difference between the two circumferences will be about 2 inches. The outside wheel on the curve therefore has a longer distance to traverse per revolution than the inside wheel, and this of course tends to compensate for the trouble due to the wheels being rigidly secured to the axles, but in practice we find that, thanks to the super-elevation and the coning, the wheels continually slip across the rail tops, moving outwards and then inwards. In a word the whole traverse of a curve is always effected, as stated

above, in a series of jerks, the violence of which depends on the condition of the road, of the tires, of the axle boxes and springs, and of the good or bad qualities of the design. In some cases the engine "rides" like a coach, the slipping being almost imperceptible, in others the action is very disagreeable and injurious to the track.

One more adverse influence has to be explained, that is to say lurching or rolling. It can best be illustrated by a practical test. If the reader will stand on a railway platform and watch an engine coming towards him at speed he will see at once what takes place. Indeed, if the road be not in perfect order and the engine well designed, he may now and then feel a little surprise that derailment does not take place. But the essential condition of safety is that the wheels should not lift off the rails. The rolling and jerking and pitching all take place, be it remembered, above the wheels. These last are always practically, at least in so far as all but the drivers are concerned, in contact with the rails. The movements of the engine above them are at once controlled by the springs and due to them, and therefore the "springing" of an engine is a very nice question of design, as on it a great deal depends. Diversities of opinion exist as to the amount of resilience permissible. The maximum range of motion allowed in an axle box in this country is, as has already been stated, about 2 inches; abroad it is almost always 3 inches, not infrequently 4 inches. But balance beams or compensating levers profoundly affect the range.

So far we have confined our attention to the engine only, but the engine when at work is either coupled to a tender or a train. In the former case, two buffer heads, actuated by a powerful cross spring or two helical springs under the tender, rest against the transverse hindermost plate of the engine framing. The tie bar between the engine and tender is secured by a pin dropped into eyes in a casting under the footplate provided for them. The result is that the engine and tender resist lateral bending effort, and so the stress when passing round a curve is increased. The same thing happens when a tank engine is tightly coupled to a train.

A review of all the conditions shows that a locomotive engine and tender are specially contrived to run straight on straight roads; and that although devices are provided to permit the lateral flexure required to traverse a curve, yet that all these are, regarded from one point of view, of a nature to favour derailment, and that so powerfully that a mistake might easily render it impossible for a locomotive to traverse curves of even great radii without risk. Thus, for example, a long six-wheeled engine tight to gauge could not get round if the controlling springs of a traversing axle were too stiff and unyielding. It may be added that the conditions are so variable and complicated that minute calculation is set at defiance, and the lateral resistance put in is settled by the results of experience, and it is never made greater than will just suffice to meet the conditions.

Before leaving this section of our subject it is worth while briefly recalling to the reader's notice a few important facts. In the first place, as has been already set forth in Chapter I., if a railway were absolutely level and smooth, and the wheels truly cylindrical, springs and bogies would not be needed. At the most, indeed, india-rubber blocks interposed between the axle boxes and frames to deaden vibration could satisfy all the vehicular conditions. Secondly, the railway of reality is curved. It is not level and it is not smooth. The task of the designers and builders of locomotives is not only to produce a machine which can pull a train, but to reduce to the lowest possible point the effects of the external disturbing agencies due to the imperfections in the road. It is not enough in getting out a design to put in sufficient boiler power, an excellent engine, and so on. The locomotive as a machine which has to traverse an imperfect road at a very high speed is a much more important consideration. It will not do to say of a given engine that it is more economical of fuel than any other on a given line, if it is feared that it will run off the track if driven at more than 50 miles an hour. This, it may be added, is in no way a fancy picture; many engines of the kind have been built. Take, as an example, the Great Liverpool, a very powerful engine designed by the late Mr. Thomas Crampton many years ago. The engine could not

be used because it broke the rails. In the present day, a wide difference exists among locomotives doing the same work at the same speeds, some being much lighter on the permanent way than others. It has been said of a big engine that "she never got through a week without breaking a rail." Too much stiffness, too much flexibility, bad springing, bad distribution of weight, and various other factors which will be dealt with when we come to consider the internal disturbing forces of a locomotive contribute to the unhappy result.

CHAPTER V

WHEELS

OBVIOUSLY, the wheels of a vehicle are an important part of it. It is time now to speak in some detail of those of a locomotive. In the earlier history of locomotives they were made of cast iron, round which a wrought iron tire was shrunk on; the tires were rolled in straight bars, cut off in lengths, scarfed at the ends, bent into rings and welded. They frequently broke at the weld. It is said that in the early days of the London and Birmingham Railway a driver of an up train at night, when passing Tring, felt the engine jump, but nothing more happened except that she ran roughly the rest of the trip to London. On going round with his lamp at Chalk Farm he found that one of the driving-wheel tires had come off. The journey was completed on the wheel centre. The tire was found in the ditch next day near Tring. Very dreadful accidents have resulted from broken tires.

Many years have elapsed since a method of producing tires of solid steel without a weld was invented, and tires so made are invariably used now. A suitable steel billet or ingot is forged into the shape of a cheese under a heavy steam hammer. Through the centre of this steel cheese a succession of punches, larger and larger, are driven until the cheese has become a very thick ring. This is heated and placed on the beak of a special anvil, and forged out until it is perhaps half the finished diameter, and is then put on to the central vertical roller of a very powerful machine.

There are various tire-rolling machines in use. It will suffice to illustrate one of the latest type, which is made by Messrs. P. R. Jackson & Company, Limited, Salford, Manchester. In the space at disposal it is impossible to illustrate the details of a

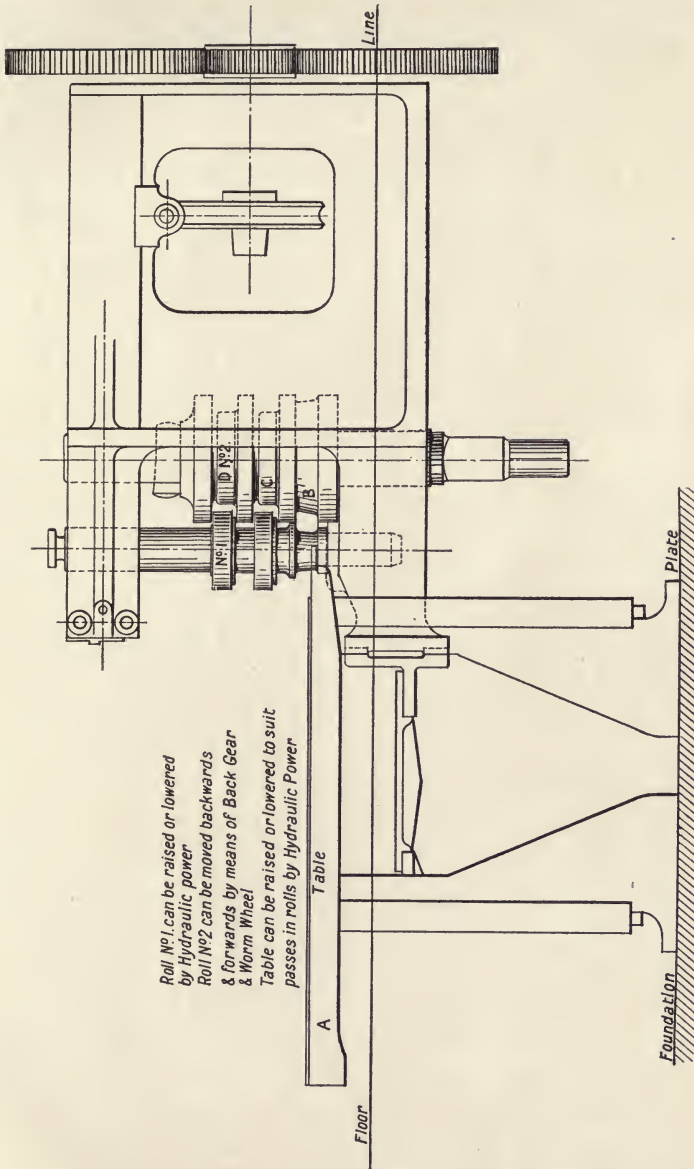

*Roll No 1 can be raised or lowered
by Hydraulic power
Roll No 2 can be moved backwards
& forwards by means of Back Gear
& Worm Wheel
Table can be raised or lowered to suit
passes in rolls by Hydraulic Power*

FIG. 32.—Tire-rolling mill.

very large and complex machine ; only the outline is given on page 41, Fig. 32. It is 20 feet 6 inches long on the floor line, and about 15 feet high from the base. The tire, whatever its diameter, is laid on a horizontal circular table A. The tire is first roughed out between the two rolls to the section marked B ; then the table is raised and the tire is passed through the grooves C, and again through the grooves D, and so finished. Described more in detail, these mills roll tires up to 9 feet diameter. The tires are rolled on a horizontal table, the rolls being vertical, and having two to four grooves for roughing and finishing the tire at one operation. The table carrying the tire is adjustable vertically to suit the rolls. This adjustment is quickly made through a hydraulic cylinder and suitable gearing. The table is fitted with rolls for carrying the tires, and with a movable carriage moved back by the tire as it enlarges, and carrying a top roll, assisting to keep the tire true ; also with side rolls working on slides. A very sensitive gauging apparatus is provided for indicating the size of tire, the pointer and index being on the front side of the main frame. The levers and handles are also on the same side and placed as most convenient for use. In some cases the main or large roll is cast complete and the grooves turned in it, the roll then being changed for different sections, or, as is now more general, the centre of the roll is a forged steel shaft, and loose rolls for the various sections are put on it. These loose rolls are readily changed for the various sections. The smaller roll working inside the tire is quickly raised and lowered by a hydraulic cylinder. The large roll moves in and out a distance of 21 inches, allowing for the changing of the loose rolls and the greatest thicknesses of tire blooms. The roll is carried by bearings at top and bottom on strong slides worked by screws in the main frame. The slides have a slow speed for the rolling pressure and a quick speed for bringing the rolls up to the work and for reversing. The roll is turned by a large bevel wheel at the foot, driven by a steel bevel pinion on the shaft running under the main frame to the driving wheels at the engine.

The mill consists of a cast iron main frame, fitted with strong

slides and screws for moving the main roll shaft in and out, the slides forming the bearings for the roll. The main frame carries the bearings for the small roll, and is provided with a bracket and hydraulic cylinder for lowering and raising this roll in and out of the tires. The frame also carries a double cylinder engine, 8-inch cylinders with quick spur gear and slow worm gear for working the slides (carrying the roll shaft) in and out. The roll shafts are of steel, the shaft for the large or main roll, *i.e.*, the roll working on the outside of the tire, being 13 inches in diameter at the bottom bearing, and it can be made up to 11 inches diameter of top bearing. The shaft for the smaller roll, *i.e.*, the roll working on the inside of the tire, can be made up to 11 inches diameter in the top bearing. The large roll shaft is also supported on a cast iron sliding footstep and stand, and is provided with a steel bevel wheel about 6 feet diameter and steel pinion about 2 feet 9 inches diameter, 5-inch pitch, 14 inches wide.

The positive screw motion for forcing the rolls together during the rolling ensures an even thickness and full section and true rolling of the tire, which is said to be lacking in mills with only a hydraulic forcing motion. The hydraulic motion is found to be more or less yielding, and to give unequal thicknesses and hollow places on the surface of the tire. About 100 wagon tires can be made per day.

As far back as 1835, John Day invented and patented a method of making railway wheel centres which was universally adopted and remained in use until a comparatively recent period. He welded up, in wrought iron, T-shaped pieces, each of which formed a portion of the circular rim, one spoke and a part of the hub or boss. The whole was gradually welded up by highly skilled wheel-smiths. The hub being first completed, the ends of the portions of the felloes—the heads of the T's—did not abut against each other, filling pieces called “gluts” being welded between them. Very great care was required to secure sound welds and a good finish, the forgings undergoing little dressing-up after they left the smith's shop. The hubs were bored to fit the axle, and turned up to a true circle. The tire was subsequently

shrunk on. The wheels were forced on to the axle by hydraulic pressure and put in a tire lathe, by which they were made truly cylindrical. Very beautiful workmanship distinguished most of these wheels. About the year 1860, M. Arbel, a French iron-master, greatly simplified the whole process. The separate parts were stamped out in dies and then grouped. The whole was raised to a welding heat. A white-hot cylindrical plate of iron was put under and another over the inner ends of the spokes, and the whole placed under an exceedingly powerful hydraulic press and welded up at one blow, so to speak. Large driving wheels required two heats to finish them. In 1862, in London, Herr Krupp, of Essen, exhibited cast steel disc driving-wheels. That is to say, the place of the spokes was taken by a disc, not flat, but slightly curved in and out to give elasticity. They were marvellous castings for the period, or indeed for any period. What they cost, who can tell? It was claimed for them that they did not raise as much dust as spoke wheels. They were tried in Germany, but nothing came of them.

For many years the wrought iron wheel has been given up. It was very expensive to make and so full of centres of danger in the numerous welds that it was easily superseded by cast steel as soon as the steel founders had overcome the difficulties which attend the production of all steel castings. These difficulties are largely the result of the very high temperature at which steel melts. One consequence is that the metal when poured attacks the surface of the mould, melting the sand, and so not only injuring the surface of the finished casting, but developing gases which are occluded in the steel, producing blow holes and honey-combing. The history of steel founding is for many years a history of failure. By degrees troubles have been overcome, and steel castings can now be had with as much certainty of soundness as those of cast iron. To the late Mr. Francis Webb, locomotive superintendent of the London and North Western Railway, the world is indebted for an exceedingly beautiful method of casting steel wheels. The moulds are mounted horizontally on whirling tables, and as the metal is poured in at the centre, the moulds revolve, and by centrifugal effort the metal

is forced outward into the minutest cranny of the mould, and sound castings result. For locomotives and tenders the use of cast steel centres is now all but universal. Some very ingenious machinery has also been introduced for cutting felloes and spokes to shape, or, more strictly speaking, taking off the rough surface of the casting, and so imparting that finish of which British engineers are proud.

In all cases the wheels are fitted with separate tires. These are usually 3 inches thick in the tread, before they wear. They are put in the lathe and turned up from time to time as they wear until they are reduced to about one half their original thickness, when they are sent to the scrap heap and replaced by new tires. The wheel centre never wears out, and breakages are very rare. It is a matter of the last importance that the tires shall be firmly secured on the wheels. The shrinking on is a very simple matter. The tire is bored out a small fraction of an inch too small in diameter to go on the wheel centre cold. The usual allowance for shrinkage is as follows: for 4 feet internal diameter, .042 inch; for 5 feet, .049 inch; 6 feet, .058 inch, which are the thicknesses of wires, Nos. 19, 18, and 17, Birmingham wire gauge. The centre is laid flat on a large circular cast iron slab similar to that which may be seen outside village smithies, and used for putting tires on wooden cart wheels. Close by is a reverberatory furnace, in which tires are heated while resting on a sand bed to little more than the temperature of boiling water. A couple of labourers take out a tire with the aid of a small crane, and brushing away dirt they drop it down on the wheel centre. If it is a shade tight the blow of a heavy wooden pounder sends it home. As it cools it contracts, and seizes the wheel centre. In some cases the tire is heated by a ring of gas jets, urged by a moderate blast. This is cleaner and much less likely to set up oxidation of the surfaces than in the furnace. For some sections of tire, as will be understood further on, the process is reversed. The tire is laid on the plate and the cold wheel centre is dropped into it. Much care is taken that the boring of the tire and the turning of the wheel centre shall be so managed that the tire shall not be stressed when in place to

much more than about one-third of its elastic limit. The difference in diameters is expressed, as stated above, in terms of a fraction of an inch per foot in diameter of the wheel. The fraction varies with the nature of the steel used, and indeed with

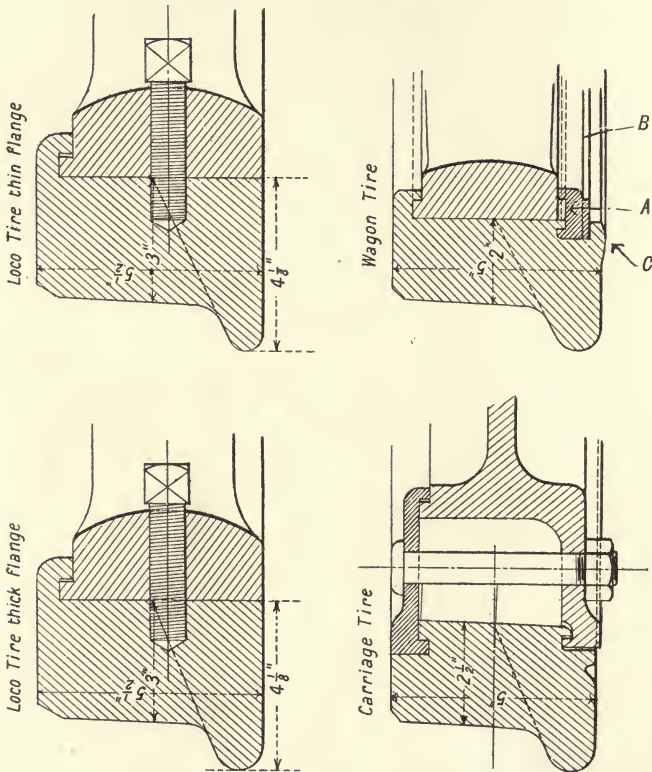

FIG. 33.—Tire sections, Lancashire and Yorkshire Railway.

the views of the wheel maker. Usually the amount of contraction allowed for is the result of practical experience rather than of theoretical estimation. It would not be safe to rely on friction to hold a tire on, and particularly a driving-wheel tire. The most obvious way of securing the wheel centre and the tire is to rivet them together, and this was the method used almost

universally for several years. The holes in the tire were made larger outside than in, and taper rivets with counter-sunk heads were used so that the tire could be trued up several times, the tapered rivet of course retaining a good hold. But the tires often broke through the holes, riveting was given up as dangerous, and numerous very ingenious devices were invented

and patented for securing tires without boring holes in them. Some of these are illustrated in the drawings of wheel sections on pp. 46, 47, and 52. The illustrations given in Fig. 33 are sections of standard engine, carriage, and wagon tires on the Lanca-

shire and Yorkshire Railway. The thin flange is used on middle wheels to give more clearance on curves for reasons already fully explained. The engine tire is secured by about a dozen screwed set bolts and an outer lip, the object of which is to prevent the wheel from being forced outward through

the tire, as in rounding curves. The wagon tire is given because it illustrates a very popular method of securing tires. Here the wheel centre is dropped into the tire, which has an outer lip just like the engine tire. Then a ring A is put in—there is sufficient clearance between it and C. This is then forced home by the ring B, which is of soft steel. One end is put in place first and driven home. The rest is then gradually forced into place, and then C is beaten down on it all round with swages

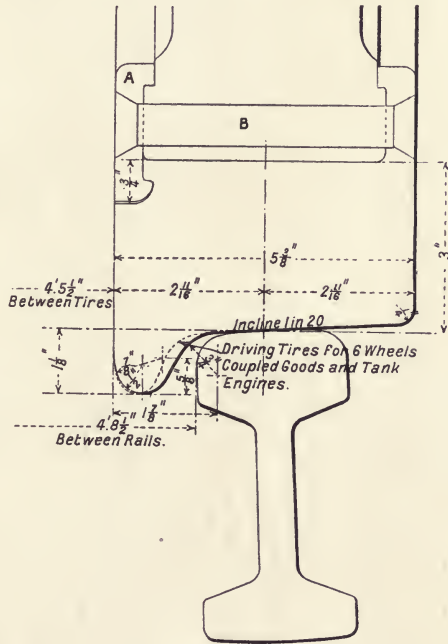

FIG. 34.—Standard tire and rail, Great Eastern Railway.

the tire, as in rounding curves. The wagon tire is given because it illustrates a very popular method of securing tires. Here the wheel centre is dropped into the tire, which has an outer lip just like the engine tire. Then a ring A is put in—there is sufficient clearance between it and C. This is then forced home by the ring B, which is of soft steel. One end is put in place first and driven home. The rest is then gradually forced into place, and then C is beaten down on it all round with swages

THE RAILWAY LOCOMOTIVE

RAILWAY.	TIRE	A.	B.	C.	D.	E.	F.	G.	H.
BARRY	{ Loco....	5½	3½	3	5	—	159	—	1½
	{ Carriage	5½	2½	½	5	2	123	—	1½
	{ Wagon	5½	2½	½	5	2	150	—	1½
BELFAST AND NORTHERN COUNTRIES	{ Loco....	5½	3½	15	7	—	17	119	1½ and 1½
	{ Carriage	5	2½	10	7	23	16	—	1½
	{ Wagon	5	2½	10	7	23	16	—	1½
BREGON AND MERTHYR	{ Loco....	5½	3½	15	7	—	131	—	1½
	{ Carriage	—	—	—	—	—	—	—	—
	{ Wagon	—	—	—	—	—	—	—	—
CALEDONIAN	{ Loco....	5½	3½	15	13	—	2½	127	1½
	{ Carriage	5	2½	10	13	2	113	—	1½
	{ Wagon	5	2½	10	13	2	113	—	1½
CAMBRIAN	{ Loco....	5½	9	1½	13	27	122	1½	1½ and 1½
	{ Carriage	5½	2½	10	13	27	17	—	1½
	{ Wagon	5	2½	10	13	27	17	—	1½
DISTRICT	{ Loco....	5½	3½	15	7	—	113	—	1½
	{ Carriage	5	2½	10	7	—	113	—	1½
	{ Wagon	5	2½	10	7	—	113	—	1½
EAST AND WEST JUNCTION	{ Loco....	5½	3½	15	7	—	13	17	1½
	{ Carriage	5	2½	10	7	2	14	—	1½
	{ Wagon	5	2½	10	7	2	113	—	1½
FURNESS	{ Loco....	5½	3½	15	12	—	13	5	1½
	{ Carriage	5	2½	10	12	2	115	—	1½
	{ Wagon	5	2½	10	12	2	115	—	1½

WHEELS

GREAT CENTRAL	Loco.... Carriage Wagon	5½	3½	—	—	—	—	127	1½
		5	2½	0	—	—	—	132	1
		5	2½	1	—	—	—	132	1
GREAT EASTERN	Loco.... Carriage Wagon	58	3½	1½	1½	1½	14	15	15
		5	2½	½	—	—	—	113	1
		5	2½	½	—	—	—	132	1
GREAT NORTHERN OF IRELAND...	Loco.... Carriage Wagon	58	3	1	13	13	151	147	1½
		5	2½	½	—	—	—	164	1
		5	2½	½	—	—	—	151	1
GREAT NORTHERN OF SCOTLAND	Loco.... Carriage Wagon	5½	3½	1½	7	7	2½	13	1½
		5	2½	½	—	—	—	116	1
		5	2½	½	—	—	—	132	1
GREAT SOUTHERN AND WESTERN	Loco.... Carriage Wagon	5½	3½	1½	7	7	153	147	1½
		5	2½	½	—	—	—	132	1
		5	2½	½	—	—	—	132	1
GREAT WESTERN OF ENGLAND...	Loco.... Carriage Wagon	5¾	3	1½	7	7	2	13	1½ and 15
		5	2½	½	—	—	—	132	1
		5	2½	½	—	—	—	132	1
GLASGOW AND SOUTH WESTERN	Loco.... Carriage Wagon	58	2½	1	13	13	17	132	1½
		5	2½	½	—	—	—	132	1
		5	2½	½	—	—	—	132	1
HIGHLAND	Loco.... Carriage Wagon	5½	3½	1½	7	7	113	119	1½
		5	2½	½	—	—	—	132	1
		5	2½	½	—	—	—	132	1
HULL AND BARNSELY	Loco.... Carriage Wagon	5½	3½	1	7	7	115	113	1½
		5	2½	½	—	—	—	132	1
		5	2½	½	—	—	—	132	1

RAILWAY.	TIRE.	A.	B.	C.	D.	E.	F.	G.	H.
LANCASHIRE AND YORKSHIRE ...	{ Loco....	5 $\frac{1}{2}$	3 $\frac{1}{2}$	1	7 $\frac{1}{2}$	—	1 $\frac{13}{16}$	1 $\frac{5}{8}$	1 $\frac{3}{32}$
	{ Carriage	5	2 $\frac{1}{2}$	5 and $\frac{1}{2}$	1 $\frac{13}{16}$	—	1 $\frac{13}{16}$	—	1 $\frac{1}{16}$
	{ Wagon	5	2 $\frac{3}{32}$	8	1 $\frac{1}{16}$	—	1 $\frac{13}{16}$	—	1 $\frac{1}{16}$
LONDON, BRIGHTON AND SOUTH COAST	{ Loco....	5 $\frac{1}{2}$	3 $\frac{1}{2}$	1	1	—	2 $\frac{5}{16}$	2 and 1 $\frac{3}{32}$	1 $\frac{9}{32}$ and $\frac{31}{32}$
	{ Carriage	5	2 $\frac{3}{32}$	3 $\frac{1}{2}$	3 $\frac{1}{2}$	—	1 $\frac{10}{16}$	—	1 $\frac{5}{32}$
	{ Wagon	5	2 $\frac{3}{32}$	3 $\frac{1}{2}$	3 $\frac{1}{2}$	—	1 $\frac{13}{16}$	—	1 $\frac{5}{32}$
LONDON AND NORTH WESTERN...	{ Loco....	5 $\frac{3}{4}$	3 $\frac{3}{4}$	1 $\frac{1}{2}$	7 $\frac{1}{2}$	—	1 $\frac{7}{16}$	1 $\frac{7}{16}$	1 $\frac{1}{4}$
	{ Carriage	5	2 $\frac{1}{4}$	6	3 $\frac{1}{2}$	—	1 $\frac{11}{16}$	—	1 $\frac{31}{32}$
	{ Wagon	5	2 $\frac{1}{10}$	3 $\frac{1}{2}$	1	—	1 $\frac{10}{16}$	—	1 $\frac{11}{16}$
LONDON AND SOUTH WESTERN...	{ Loco....	5 $\frac{1}{2}$	3 $\frac{3}{4}$	1 $\frac{1}{2}$	1 $\frac{13}{16}$	—	1 $\frac{7}{16}$	1 $\frac{7}{16}$	1 $\frac{9}{16}$
	{ Carriage	5 $\frac{1}{4}$	2 $\frac{3}{8}$	1 $\frac{1}{2}$	1	—	1 $\frac{7}{16}$	—	1 $\frac{1}{16}$
	{ Wagon	5 $\frac{1}{4}$	2 $\frac{3}{8}$	1 $\frac{1}{2}$	1 $\frac{5}{16}$	—	1 $\frac{7}{16}$	—	1 $\frac{1}{16}$
LONDON, TILBURY AND SOUTHWEND	{ Loco....	5 $\frac{1}{2}$	3 $\frac{3}{4}$	1 $\frac{11}{16}$	1 $\frac{11}{16}$	—	1 $\frac{13}{16}$	—	1 $\frac{9}{16}$
	{ Carriage	5	2 $\frac{3}{8}$	1 $\frac{11}{16}$	1	1	1 $\frac{11}{16}$	—	1 $\frac{11}{16}$
	{ Wagon	5	2 $\frac{3}{8}$	1 $\frac{9}{16}$	1	1	1 $\frac{11}{16}$	—	1 $\frac{11}{16}$
MIDLAND	{ Loco....	5 $\frac{1}{2}$	3 $\frac{3}{4}$	1 $\frac{1}{2}$	1 $\frac{5}{16}$	—	1 $\frac{7}{16}$	1 $\frac{7}{16}$	1 $\frac{13}{16}$
	{ Carriage	5	3 $\frac{1}{4}$	—	—	—	1 $\frac{7}{16}$	—	1 $\frac{11}{16}$
	{ Wagon	5	—	—	—	—	1 $\frac{13}{16}$	—	1 $\frac{13}{16}$
MIDLAND GREAT WESTERN OF IRELAND	{ Loco....	5 $\frac{1}{4}$	3	1 $\frac{1}{4}$	3 $\frac{1}{4}$	—	1 $\frac{11}{16}$	1 $\frac{7}{16}$	1
	{ Carriage	5	2 $\frac{1}{2}$	1 $\frac{1}{16}$	3 $\frac{1}{4}$	—	1 $\frac{10}{16}$	—	1
	{ Wagon	5	2 $\frac{9}{32}$	7 $\frac{1}{8}$	3 $\frac{1}{4}$	—	1 $\frac{11}{16}$	—	1
NORTH BRITISH	{ Loco....	5 $\frac{1}{2}$	—	—	—	—	1 $\frac{7}{16}$	1 $\frac{1}{2}$	1 $\frac{9}{32}$
	{ Carriage	5	—	—	—	—	1 $\frac{13}{16}$	—	1 $\frac{1}{16}$
	{ Wagon	5	2 $\frac{3}{32}$	—	—	—	1 $\frac{10}{16}$	—	1 $\frac{31}{32}$

WHEELS

NORTH EASTERN	{ Loco... Carriage Wagon	5 $\frac{1}{2}$ 5 5	3 $\frac{3}{4}$ 3 $\frac{3}{4}$ 2 $\frac{3}{4}$	1 $\frac{11}{16}$ 1 $\frac{11}{16}$ 1 $\frac{11}{16}$	1 $\frac{13}{16}$ 7 8	— 1 —	2 1 $\frac{13}{16}$ 1 $\frac{13}{16}$	1 $\frac{11}{16}$ — —	1 $\frac{3}{8}$ 1 $\frac{3}{8}$ 1 $\frac{3}{8}$
NORTH LONDON	{ Loco... Carriage Wagon	5 $\frac{3}{4}$ 5 5	3 $\frac{1}{2}$ 2 $\frac{1}{2}$ 2 $\frac{1}{4}$	1 $\frac{1}{16}$ 1 $\frac{1}{16}$ 1 $\frac{1}{16}$	1 $\frac{1}{4}$ 1 $\frac{1}{4}$ 1 $\frac{1}{4}$	— 1 $\frac{11}{16}$ —	1 $\frac{1}{8}$ 1 $\frac{7}{8}$ 1 $\frac{7}{8}$	1 $\frac{1}{8}$ — —	1 $\frac{3}{8}$ 3 $\frac{1}{8}$ 1 $\frac{1}{4}$
NORTH STAFFORDSHIRE	{ Loco... Carriage Wagon	5 $\frac{1}{2}$ 5 5	— — —	— — —	— — —	— — —	1 $\frac{15}{16}$ 1 $\frac{15}{16}$ 1 $\frac{15}{16}$	1 $\frac{3}{4}$ — —	1 $\frac{1}{8}$ 1 $\frac{3}{8}$ 1 $\frac{3}{8}$
PORT TALBOT DOCKS	{ Loco... Carriage Wagon	5 $\frac{1}{2}$ 5 5	3 $\frac{3}{4}$ 2 $\frac{1}{2}$ 2 $\frac{3}{4}$	1 1 1	1 1 1	— 1 —	1 $\frac{7}{8}$ 1 $\frac{5}{8}$ 1 $\frac{5}{8}$	1 $\frac{11}{16}$ — —	1 $\frac{1}{8}$ 1 $\frac{1}{8}$ 1 $\frac{3}{8}$
RHYMNEY	{ Loco... Carriage Wagon	5 $\frac{3}{4}$ — —	3 $\frac{1}{16}$ — —	5 — —	7 8 10	— — —	1 $\frac{29}{32}$ — —	1 $\frac{23}{32}$ — —	1 $\frac{9}{32}$ and 1 $\frac{27}{32}$ — —
SOUTH EASTERN, CHATHAM AND DOVER	{ Loco... Carriage Wagon	5 $\frac{1}{2}$ 5 5	3 $\frac{3}{4}$ 2 $\frac{3}{4}$ 2 $\frac{3}{4}$	1 1 1	1 $\frac{13}{16}$ 1 $\frac{13}{16}$ 1 $\frac{13}{16}$	— 1 —	1 $\frac{7}{8}$ 1 $\frac{7}{8}$ 1 $\frac{7}{8}$	1 $\frac{11}{16}$ — —	1 $\frac{9}{16}$ 1 $\frac{3}{8}$ 1 $\frac{3}{8}$
TAFF VALE... ..	{ Loco... Carriage Wagon	5 $\frac{1}{2}$ 5 5	3 $\frac{1}{2}$ 2 $\frac{1}{2}$ 2 $\frac{1}{4}$	1 1 1	1 $\frac{1}{2}$ 1 $\frac{1}{2}$ 1 $\frac{1}{2}$	— 1 —	1 $\frac{1}{2}$ 1 $\frac{1}{2}$ 1 $\frac{1}{2}$	— — —	1 $\frac{1}{2}$ 1 $\frac{1}{2}$ 1 $\frac{1}{2}$
<i>Suggested Standard Tive Sections</i>									
	{ Loco... Carriage Wagon	5 $\frac{3}{4}$ 5 5	3 2 $\frac{1}{4}$ 2 $\frac{1}{4}$	1 $\frac{1}{4}$ 1 1	7 8 9	— 1 —	1 $\frac{7}{8}$ 1 $\frac{7}{8}$ 1 $\frac{7}{8}$	1 $\frac{1}{2}$ — —	1 $\frac{1}{8}$ 1 $\frac{1}{8}$ 1 $\frac{1}{8}$

and sledge hammers. An exceedingly firm job is made in this way.

Fig. 34 is a section of a standard Great Eastern Railway tire. A ring A is dropped in here as in the wagon tire, Fig. 33, but it is secured in its place by counter-sunk rivets, B. When a tire has to be removed the rivet head at one end is drilled off, and it can then be driven out. If the tire were broken in half a dozen places it could not leave the wheel.

The thinning of the flange for the central pair of wheels in a six-coupled engine is shown by the dotted lines. The standard section of the Great Eastern main line rail is also given. The slight inward "cant" always used in order that the coned tire may get a fair bearing all over the rail table is to be noticed.

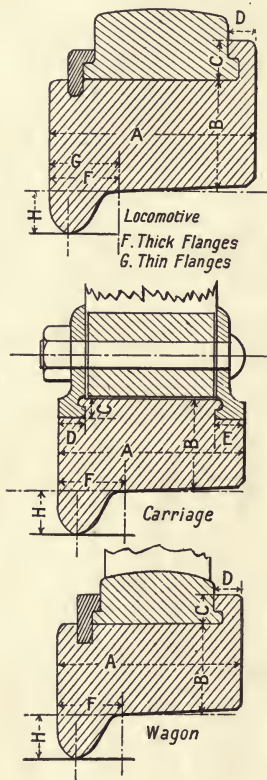

The difference between wheel-tire sections on various railways is not very great, and recently a standard section has been proposed by the Engineering Standard Committee. The accompanying table, for which the author is indebted to Mr. George Hughes, mechanical engineer-in-chief of the Lancashire and Yorkshire Railway, explains itself. It will be seen that it includes not only locomotive tires, but those of coal and goods wagons. The figures which it contains have never been made public before. They give minute information as to the dimensions adopted on thirty-two, that is to say all, the principal railways in the United Kingdom. The three sections given on this page accompany the tables.

Returning now to the construction of wheels, it may be said that the practice of securing tires by steel screwed pins passing

through the felloes and some way into the tire has become quite usual. It is very simple and cheap. The screwed studs are a tight fit and seldom or never work loose. When a tire has to be renewed they are easily screwed out. The tire is heated by a ring of gas jets until it is sufficiently expanded, when it is lifted off. It will be enough to add here that probably as many as fifty different practicable methods of securing tires on railway wheels have been patented, if not tried, on various railways at home and abroad.

CHAPTER VI

WHEEL AND RAIL

THIRTY or forty years ago, while rails were still made of wrought iron, the weights of locomotives gradually increased. The load on driving wheels at last reached as much as nine tons on each. The result was that rails began to give way. They split along the top, and their ends "were beaten into besoms." Numerous devices were schemed to get over the

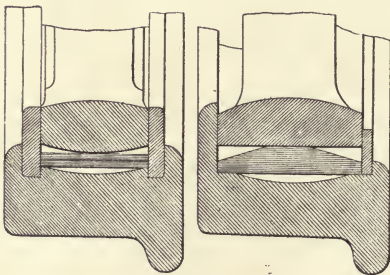

FIG. 35.—Adams' elastic wheel.

difficulty. We need only now concern ourselves with one. It was agreed that if a railway wheel was itself elastic the rail would be spared much hardship. A modern driving wheel weighs with the tire complete from three-quarters of a ton to one-and-a-quarter tons, according to the diameter. This is dead weight and not, like that of the engine, spring-carried. In the United States a Mr. Griggs mounted his tires on hardwood wedges driven between the felloe and the tire, with the immediate result that he greatly prolonged the life of his tires. In this country Mr. Bridges Adams, the inventor of the traversing axle box already referred to, invented and patented about 1858, and, what is more to the purpose, fitted engines and waggons with, the wheel shown in Fig. 35. It is stated that he got excellent results. A steel ring or rings was interposed between the tire and the centre. The ring was supposed to give way slightly under the tread of the wheel. The system got a fair trial on

several lines, with the result that the lives of the iron tires then used were more than doubled. All devices of this kind were, however, rendered unnecessary by the universal adoption of steel rails, which will not split, and steel tires. It is worth notice that these last were looked on with much doubt at first by locomotive superintendents, as it was held that a hard steel tire could not get a good grip of a hard steel rail. There was some truth in the argument, but not much. The mention of it leads directly, however, to a very important question which is best considered here, although it has only indirectly to do with the locomotive considered as a vehicle—a very expressive word first applied by a French engineer, Count Pambour, namely “adhesion.”

It is not necessary to do more than call attention to the fact that a locomotive depends for its motion along the rails on the same causes as those which determine the movement of a bicycle or a motor car. The engine tries to turn the driving wheel round. This it cannot do unless the wheel moves forward, because of the friction between its rim and the road. Now if we confine our attention to a driving wheel and a rail we shall find much that repays consideration. The surface of the tire is very hard—so hard that it can scarcely be cut by a file, and turning a tire up is a tedious process, and can only be carried out by special tools. The surface of the rail although softer is also hard. The hard and rigid tire rests on a hard and rigid rail—what is the contact surface between them? Absolute hardness and stiffness would entail a line contact across the rail table, because a geometrical circle can touch a straight line or double tangent only at a geometrical point. In practice, of course, some give and take occurs. The tire flattens and the rail bends a little, and so contact becomes more than a line. As far back as 1845, Mr. Samuelson carried out some experiments on the Eastern Counties Railway—now the Great Eastern—to ascertain the area of contact. He used gold leaf slips pushed under a driving-wheel in front and behind, and measured the distance between them. The weight on the rail was, however, only about three tons. In 1865 the author made

some experiments on the same railway, by Mr. Sinclair's permission, with the same object, and with several locomotives having driving wheels 5 feet to 6 feet 6 inches in diameter, and carrying loads of five to five-and-a-half tons on steel tires in fair order. A part of the rail being well cleaned, the engine was brought over the spot and two slips of thin stiff paper, or in some cases thin sheet iron only $\frac{1}{1000}$ of an inch thick, were placed on the rail, one in advance and the other in the rear of the vertical line descending from the axle through the locus of contact of the wheel and the rail. These slips were then brought together as closely as the wheel would permit. That is to say, they were wedged between the tire and the rail until the distance between these was so small that the slips could go no further. It is obvious that so long as the tire is removed from the rail by the smallest conceivable fraction of an inch no contact exists. It is also clear that the curve of the tire near the point of contact and the rail very nearly approximate to parallel lines. That is to say, the curve of the tire and the rail table includes so small an angle that we are justified in making a considerable deduction from the length of contact surface as determined by these experiments. A mean of six experiments gave $\frac{3}{8}$ inch. The length of surface of true contact was, however, not more than half this, or say $\frac{3}{16}$ inch. The breadth of surface of contact measured by the bright ribbon worn on the rail table would be about $1\frac{1}{2}$ inches, and the whole area of contact say a fraction over one square inch. In this case, however, the rail was of iron, and did not weigh more than about 68 lbs. to the yard; the rails of the present day weigh from 90 lbs. to 105 lbs. per yard, and the whole road is incomparably more rigid than anything existing in 1865. There is every reason to think that, at all events with fairly new tires and new rails, the surface of contact may not exceed half a square inch. Now the total load on the rail, including the weight of the complete wheel, with its axle, axle box, and spring, will be anything between eight and nine tons. Consequently the stress between wheel and rail will be at the rate of at least 8 by 2, or sixteen tons per square inch, and may reach very much more, as well as much less, when the

engine, running at high speed, is also rolling on its springs. There is besides another and very important factor exerting its influence on the relations between wheel and rail which will be understood when the internal disturbing forces are dealt with. How, it may be asked, can a rail table escape being crushed by a load so heavy as sixteen tons to the square inch, which is close to or above the elastic limit of many rail steels? The tire is so hard that it may escape. The only explanation is that the portion of steel which carries the load is supported by the metal all round. It is, so to speak, in the same position as would be a steel peg driven into a hole in the rail. It cannot spread or move in any direction, and therefore the rail table is not torn to pieces all at once, but is slowly disintegrated.

It has been necessary to consider this point at considerable length because two factors of great importance are involved. In the first place, the weight that may be placed on any one pair of wheels is limited by two considerations. The first is what will the rails stand? the second is what will the bridges stand? Both these are affected by the performance of the locomotive as a vehicle.

CHAPTER VII

ADHESION

THE author has written to little purpose if he has not made it clear that the pressure of a wheel on a rail continually varies. Now the better the design of the engine the less will this variation be. Thus, the use of balance beams will assuredly distribute weight, rendering the whole machine more flexible vertically. But it may be taken as proved that, in this country at all events, a load of twenty tons must never be exceeded on two wheels, and that in good practice eighteen tons is considered the maximum. It will be seen presently that if the load could be doubled, or even increased by 50 per cent., important advantages would be gained. As for bridges they could be strengthened, but it would be impossible to make tires or rails that could endure the additional stress. The rail tables would give out for the reasons stated above, and the tires, however hard, would be very short-lived.

In practice it is the rule to put the greatest possible weight on the driving wheels, because this weight determines the efficiency of the locomotive as a hauling machine. The conditions prevailing between wheel and rail are quite outside those of ordinary friction, in that the loads carried are excessive. It has become the custom, therefore, to speak of locomotive "adhesion," the word being used in a sense quite different from that given to it in dictionaries; what is its co-efficient we shall see further on. It must be kept steadily in mind that if the phenomena of locomotive adhesion had no existence engines with smooth driving wheels would possess no power of locomotion. Adhesion is as necessary as steam in the cylinder or coal in the fire-box. It lies at the root of every calculation and enters into every

formula intended to determine the tractive power of a locomotive. Again, after a certain point has been reached, raising pressures or increasing the size of cylinders or boilers—the augmentation, in short, of every element that represents energy—will not confer the least practical advantage. On the foothold, so to speak, of an engine depends its hauling power. Adhesion means foothold, no more and no less. What its relations are to ordinary friction has been the subject of many discussions; that it is akin to statical friction is clear, because the tire is always at rest however fast the train is running with regard to the rail, unless the wheel slips. It would, however, be mere waste of time to try to draw a parallel between the two. Railway authorities have long since made up their minds and settled on a co-efficient for adhesion which has proved to be of sufficiently general application, and so nearly accurate that the design of any locomotive can so far be based on it with satisfactory results. In this country the co-efficient is one-sixth. This means that, unless the force tending to make the wheel revolve measured at the point of contact with the rail is greater than one-sixth of the vertical stress between wheel and rail, the wheel will not slip. Thus, if the load is nine tons, then the turning moment must exceed 1.5 tons, or the wheel will not slip. In the United States it is usual to take the co-efficient at one-fifth or a little more. Climate exercises a very important influence on adhesion. The co-efficient is highest when the rails are quite clean, dry, and moderately warm. Under a tropical sun the co-efficient is a little reduced. When a rail is thoroughly wet and washed clean the adhesion does not suffer much. In fog or damp weather, particularly if the rail is dirty, as it is sure to be near cities because of smoke, adhesion almost vanishes. The wheel spins round on the rail without moving the engine. Various devices have been schemed for augmenting adhesion, one of which—the coupling of driving wheels—must be considered here, because the use of coupled wheels affects the performance of the locomotive as a vehicle, and modifies its design very considerably.

As we have seen, by degrees the outside bearing was given up, and in the present day the inside bearing alone is almost always

used in Great Britain for passenger engines. Exceptions may, however, be found in other countries. Statistics carefully collected by the late William Adams on the North London Railway showed that steel crank axles with inside bearings would run about 120,000 miles without failure, while those with outside bearings had a life of only about 60,000 miles.¹ With the much larger cylinders and heavier pressures of the present day the disparity in endurance would no doubt be much greater.

In pursuit of greater adhesion, two, three, or more pairs of wheels are coupled so that they must all revolve together. The coupling might be effected by cogged wheels or by chains, but a far more simple and elegant device is used. In each driving wheel a crank pin is fitted, and a rod extends from crank pin to crank pin. The pins at opposite sides of the engine are set at 90 degrees apart, so that if all the pins at one side are in a horizontal line, and so on the dead centre, all those at the other side are fully "alive." The result is that, as we have said, any number of wheels may be coupled. The adhesion of the locomotive is, therefore, proportionately augmented; for let it be supposed that an engine has four driving wheels 6 feet in diameter, each pressing on the rail with a weight of eight tons—no coupling rods are on—then the weight for adhesion is 16 tons, and the co-efficient of adhesion being $\frac{1}{6}$, we have $\frac{16}{6} = 2.66$ tons.

If now we put on coupling rods, we get the adhesion due to the second pair of wheels, which is also 2.66 tons, and the total adhesion is now 5.32 tons, and so on. It must not be supposed, however, that this advantage can be secured without paying for it. It is well known that the resistance of the locomotive regarded as a vehicle—or, as it is sometimes, though not with strict accuracy, called, the rolling resistance—is augmented by coupling rods. Various estimates of the resistance have been made. The late Patrick Stirling, of the Great Northern Railway, often asserted that coupling rods always meant an extra fuel consumption of something over one pound of coal per mile, or say 5 per cent.

¹ These mileages do not apply to modern practice with steel crank axles.

When two axles only have to be coupled, the inequalities of the road—either end of the rod can rise or fall—have no effect. If three are coupled it is essential that a joint shall be put in the coupling rod to permit the axle centres to rise and fall above and below this horizontal line. The trailing end of each section of the coupling rod is extended past the crank pin, and an eye is forged in it, between the jaws of which the leading end of the following section of the coupling rod is secured by a pin put through the eye. This secures flexibility in a vertical plane. The crank pins are got up dead true by grinding, and the bearings are in the present day brass bushes lined with white metal, and forced and pinned into eyes at each end of the side rod. Adjustable coupling rod ends have long since been given up in this country. When they get too slack the bushes can be driven out and replaced by new bushes. The side rods are invariably made in the present day each of a single steel forging. Formerly they were made in three pieces of the best forged scrap iron, that is to say, there were the two heads, one for each end, and a middle length. There were thus two welds in each rod, and breakages constantly occurred at the welds. Then an improvement was effected by making each head in one piece with half the length of the rod, and this saved one weld. But this is all now ancient history. The stresses which a side rod has to withstand are severe. A very moderate knowledge of geometry will suffice to show that every portion of a side rod describes as regards the engine a circular path, and is consequently submitted to centrifugal effort. There are besides tensile and compression stresses. There is as a result some form of rod which will give the maximum strength with the minimum of material. What this form is has been ascertained by mathematicians. Their investigations would be out of place here; but the reader who cares for further information may be referred to the *Engineer* for January 16 and 23, February 20, and March 6, 1903, where he will find the whole subject elaborately treated at great length in a series of papers by Mr. Parr.

Some designers use fish-bellied rods, but the favourite rod, at all events for fast work, is a straight parallel bar, with a channel

cut in each side of it in a milling machine, so that it is in cross section a double-flanged girder in miniature; such rods are very handsome and very good.

Although mathematics would be out of place in this book, it is very easy to convey an idea of the amount of the stresses which a side rod has to endure. In a four-coupled engine, assuming that the adhesion is the same for all wheels, then if, as is very usual, the distance from the centre of the coupling rod pins from the wheel centre is the same as that of the crank pin centre from the centre of the axle, then the stress on the coupling rod will be equal to one half the total effort of the steam on the piston, the other half being intercepted by the driving wheel just in front. An 18-inch piston has an area of 254·5 square inches, and if the pressure is 150 lbs., then the total effort on the piston = 38175 lbs. or seventeen tons; one half of this is 8·5 tons. Now the stresses are both push and pull, push when the crank pins are below the centre, pull when they are above them. The latter is easily dealt with. A bar in tension with a sectional area of 3 square inches would be ample. But the push or thrust is quite another matter, for the bar must be stiff enough to act as a strut and withstand the tendency to bending. But the centrifugal stress is much more serious. Let us take the case of a four-coupled engine with 6-foot driving wheels, running at a little over sixty miles an hour. The crank length for the coupling rods is 12 inches. The circle described by the coupling rod pins and therefore by every portion of the rod is 2 feet in diameter, or one-third that of the driving wheel. Now the velocity of the 6-foot driving wheel rim is 88 feet per second, as regards the engine, with which fact alone we have to do. The coupling rod rotates at one-third of the speed, or say 30 feet per second. The centrifugal effort per pound weight of rod is by the rule already stated a fraction under 28 lbs. If the rod weighs 250 lbs., then the tendency to fly away from the crank pins would be a little over three tons, and twice in each revolution the rod will be in the condition of a girder, say 8 feet long, and carrying a distributed load of three tons. This transverse stress tends of course to break the rod. It will be readily understood that it is

of all things desirable that the rod should be made as light and as stiff as may be.

It has been stated above that the addition of coupling rods augments the resistance of the locomotive as a vehicle. The reason remains to be explained. The side rod compels all the coupled wheels to revolve at the same speed; but they would not if left free all make the same number of revolutions in running from, say, Euston to Birmingham, unless for one thing their circumferences were identical; but this they cannot be, for two reasons: in the first place, however accurately they have been turned to the same diameter to begin with, they will wear unequally. But, in the second place, it must be remembered that the tires are conical, not cylindrical, and that some of the flanges are pressed against the outer and some against the inner rail in rounding a curve; slipping must therefore take place, not only as between the outer and inner wheel, but as between one pair of wheels and another. This slipping is due to the coupling rods. But beyond all this, the coupling of wheels causes resistance in a way not easily explained, perhaps because the *modus operandi* is not very clearly understood. In the old sea-going days when ships sailed, and pursued and were pursued, it was well known that to get the maximum speed [the utmost possible flexibility was needed in the hull and rigging; and we read of chased schooners and luggers whose crews unwedged the masts, and even sawed deck beams through to let the hull "work." Now in something the same way, the more flexible and less rigid the locomotive as a vehicle is, the less will be its resistance. Coupling rods are more or less inimical to this flexibility. They deprive the wheels of their individuality. The go-as-you-please element is eliminated. To realise what this means it is necessary to travel first on the foot-plate of an engine with only a single pair of driving wheels and then on that of a six-coupled engine. Much can be, and is, done, of course, to render coupling as unobjectionable as possible, but it is always regarded as a necessary evil—a something to be got rid of, if only it were possible.

It has been said above that various expedients to get rid of coupling rods have been proposed and tried. Two only need be



mentioned here. The first consisted in putting sharp sand on the rail in front of the driving wheel. Unless rails are very "greasy" this will usually bring up the co-efficient of adhesion to at least one-seventh, probably to one-fifth. The sand is sometimes merely dropped on the rail through a pipe in front of the driving wheel. To this plan there are various objections; one is that sand is wasted. Instead of lying on the rail where it is wanted it falls off. Another is that suddenly, just when wheels are revolving at a high speed on a very slippery rail, one will be pulled up by sand and the other will not. The result is a very heavy stress on the crank axle, which has not infrequently been twisted across. Again the sand is apt to fall on to the oiled plates on which the tongues of crossing switches work, and cause so much friction that the signalman cannot move them. In the present day, therefore, it is usual to fit a small steam jet at each side of the engine which blows a fine jet of sand right into the place under the wheel where it is wanted.

Even in the present day there are many single driving wheeled engines at work, and they have always given so much satisfaction, they are so easy on the road, and economical in fuel, that their use has been abandoned with the utmost regret. It is worth while to digress here to say a few words about in many respects the most beautiful locomotives ever built. These were the single driver, outside cylinder engines, to which reference has already been made, designed by the late Mr. Patrick Stirling, while he was locomotive superintendent of the Great Northern Railway.

This engine weighed only 39 tons, distributed as follows :

Leading bogie wheels	7 tons.
Trailing	„	.	.	.	8 „
Driving wheels	16 „
Trailing	„	.	.	.	8 „
					39 „
Total	39 tons.

As to the performance of these engines, which conducted express traffic for many years between King's Cross, Leeds, and York, it will suffice to say that trains of from 16 to 20 coaches

represented normal loads. As many as 28 coaches have been taken and schedule time kept. These weighed 10 or 12 tons each, or say one-half the weight of a modern coach. From King's Cross to Potter's Bar, 13 miles, the work is all uphill—the sharpest curve 15 chains radius. The tractive effort of the engine would probably reach at slow speeds about 9,000 lbs. The load under the driving wheels would be 35,840 lbs., so that the co-efficient of adhesion must have reached about 0·25, which could only have been got on a dry road and with sand. Many engineers, however, believe that the co-efficient is better under a large than it is under a small wheel. Some years ago Mr. Ivatt greatly improved these engines by adding domes to them. These permitted the water to be carried at a higher level in the boiler, a matter of much importance in climbing long hills, because the feed can be cut off and the heat stored in the water used in the cylinders. When the hill was surmounted the boiler could, of course, be filled up again

CHAPTER VIII

PROPULSION

WE have now, it is believed, considered all the external disturbing forces of a locomotive engine, the principle of their action and of the methods adopted in combating them. Any reader with a mathematical turn of mind will not fail to perceive that all the questions involved admit of mathematical treatment, but everything of the kind would be out of place in a book such as this which is intended to explain in general terms why the locomotive engine is what it is. Thus the reason why the front or leading end of an engine is carried on a four-wheeled bogie instead of on two wheels has been set forth, but no attempt has been made to treat the questions raised as geometrical problems to be solved algebraically.

At the outset it was stated, it will be remembered, that the locomotive regarded as a vehicle was subjected when running to two classes of disturbing forces—the first external to it, such for example, as the imperfections of the road on which it moves; the second, internal. The first it has in common with all railway carriages, vans, wagons, &c., and indeed all vehicles traversing streets or highways. The internal disturbing forces are quite different in character, of great importance, and not so easily dealt with as the external forces.

At this point it becomes necessary to explain precisely how a locomotive is propelled—a matter concerning which entirely erroneous ideas are generally held. Thus the accepted explanation is that the driving wheel pushing back against the rail, the crank-axle bearings push forward continuously against the engine frames, the amount of the push rising and falling with the position of the crank and the pressure on the piston, but always

being forward in the direction in which the train is moving. The author believes that he was the first, many years ago, to publish a statement of the true facts in the *Mechanic's Magazine*.

The author may be permitted to quote here from a paper on "The Adhesion of Locomotive Engines," which he read before the Society of Engineers in 1865. The facts have been in no wise altered by the lapse of time :—

"For the purpose of illustration, we will assume the case of a locomotive engine with a single pair of drivers 6 feet in diameter ; the cylinders, outside, a minute fraction less than 16 inches in diameter ; the pistons having a stroke of 2 feet, and an area of precisely 200 square inches. For the present, let it be further assumed that one cylinder only is in action, the other being uncoupled, and the pressure throughout the stroke taken at 50 lbs. per square inch above the atmosphere, back pressure, &c. Suppose now that this engine is at rest on the rails in such a position that the crank stands up vertically, the crank pin being directly above the centre of the axle, and the piston approximately at half stroke. If now we turn on steam behind the piston, we shall find that it is urged forward with a force equal to 10,000 lbs. The crank pin will also be urged in the same direction with a similar force, less the small amount of loss due to the obliquity of the connecting rod, which loss we may totally disregard in the present investigation. The wheel we shall assume to have so much adhesion that no slipping takes place ; we may then regard that spoke directly in the vertical line below the crank axle as constituting with the crank a lever of the second order, in which the load to be moved (the engine) is placed between the power (applied to the crank pin), and the fulcrum (the rail) : the axle journal will then be thrust against the forward brass with a force greater than that due to the strain on the piston by an amount exactly equivalent to the proportion existing between the distances intervening between the crank pin and the rail, and the axle centre and the same point. The engine would, therefore, tend to advance with a force equal to 13,333·33 lbs., and were there nothing to be deducted these figures would represent the

gross tractive force of the machine while the crank remains vertical. But from this total we must subtract the retarding force operating on the hinder lid of the cylinder, amounting, of course, to a stress precisely equal to that on the piston, or 10,000 lbs., and we find that the gross effective force of traction is reduced to 3,333 lbs., the force at the rail, or that to be resisted by adhesion being precisely the same. The hauling power of the machine, therefore, is only due to the lever action proper to the wheel and crank, and so far it is certain that the advance of the machine is a consequence of the pressure of the crank axle on the forward brasses."

"But the crank is above the axle only during one half-revolution, and during the other half the state of affairs changes materially. Suppose all things arranged as before, the crank, however, being directly below the wheel centre instead of above it, steam being admitted in front of the piston. This last tends to move backwards in the cylinder, or in a direction contrary to that in which we wish the engine to move. This pressure is communicated directly to the crank pin, and were the wheel free it would revolve—but the wheel is not free. It now acts the part of a lever of the third order, the power (the force on the crank) being applied between the load to be moved (the engine) and the fulcrum (the rail). The crank shaft is, therefore, thrust, not against the forward brass, but against that which is behind, with a force proportional to the distance intervening between it and the rail and the crank pin and the rail. A little calculation will show at a glance that the stress on the pin being 10,000 lbs., the retarding thrust on the axle brass will be one-third less, or 6,666 lbs., while the force to be resisted by adhesion will still be 3,333 lbs. Under these conditions the machine would retrograde were it not for the force exerted by the pressure of the steam reacting from the piston on the forward lid of the cylinder, amounting to 10,000 lbs., from which, deducting 6,667 lbs., we have 3,333 lbs., as before, for the tractive force of the machine at that moment."

"From the foregoing it is clear that a locomotive is propelled during the forward stroke by the pressure on the axle brasses and

retarded by that on the hinder cylinder lid; while during the back stroke, the propulsion of the machine is due to the pressure on the forward lid of the cylinder, the strain on the axle brasses directly opposing its advance. So far we have only considered the case of an engine with a single cylinder, nor is it necessary that we should enter at any length into the phenomena presented in ordinary practice. It will be seen that the introduction of the second cylinder and piston acting at right angles to the first complicates the relations of the stresses to which the machinery is exposed without materially altering their character. Thus the engine is alternately forced forward on its path by a cylinder lid located at one corner and a shaft bearing placed in the mid length of the framing. If the thrust on the axle boxes were steadily exerted in the direction in which the engine proceeds, crank axle, brasses, and guides would give little trouble; as it is they require constant attention."

To make what takes place still clearer, let us imagine the crank pin on the dead centre. At the end of one stroke the brass will be thrust back when steam enters the cylinder, and the front cylinder cover will be thrust forward, the two efforts being equal and opposite. When the piston is at the other end of the stroke the conditions and efforts will be the same, but in the reverse direction. All the circumstances are analogous to those of rowing. The rower exerts forward effort on the rowlock, and a backward effort against the stretcher. The propelling force is the difference between the stress on the rowlock and that on the stretcher.

Summing up, we find that the crank axle brass is pushed and pulled at every revolution backwards and forwards. If longitudinal slackness existed, the axle boxes would knock in the horn plates, and to prevent this a driving-wheel axle box is always fitted with a wedge for taking up wear. See Fig. 1.

If we trace out the motion of the piston it will be readily perceived that in space it is continuously moving faster and slower than the engine. This subject has been dwelt upon because unless the relations between the piston, cylinder covers, driving wheels, and rails are fully understood much that follows will be incomprehensible.

Now, so far the engine has been dealt with as though there was only one cylinder and piston; but there are two, and their lines of action are on different vertical planes, and the motions are not simultaneous, but rhythmical. The cranks are at an angle of 90° with each other. The result is that as the engine advances along the rails it is propelled, as has been just stated, first by a cylinder cover at one side, then by an axle box at the other side, then by two axle boxes, then by two cylinder covers, then by a cylinder cover at the other side. The tendency is to set up a sinuous motion in the engine. The magnitude of this lateral movement depends on the distance of the cylinder from the longitudinal centre of the frame; and the earlier outside cylinder six-wheeled single-driver locomotives "wiggled" along the road to such an extent that some of them were termed "boxers" by the drivers, and to this day an engine is said "to box" when the leading end beats backwards and forwards. In some engines, indeed, a peculiar action takes place when the train is running on a straight piece of track. A rhythmical motion takes place, and the engine begins to "wander," swaying slowly from side to side across the road in a very alarming fashion. The moment a curve is reached wandering ceases, and it can always be stopped by shutting the regulator for a moment and so throwing the engine "out of step."

We have then, in the position of the cylinders and the mode of action of the piston and crank, one internal source of disturbance.

We have so far neglected the effect of the angular action of the connecting rods. The engine tends to revolve round the crank axle with precisely the same energy as the crank axle tends to revolve under the boiler. When the engine is running forward the cross head is pressed against the upper guide bar, and tends to lift the leading end of the engine by an amount which varies from nothing at the end of the stroke to a maximum when the piston has made a certain advance; what this point will be depends on the pressure in the cylinder. Let the length of the connecting rod be 7 feet, and that of the crank one foot, then by the composition and resolution of forces it can be shown that at a point near the middle of the stroke one-seventh of the

whole pressure on the piston will be exerted in lifting or attempting to lift the leading end of the engine. An equal effort will tend to force the crank down on the rail; thus, let the piston be 18 inches in diameter and 24 inches in stroke, and the connecting rod 7 feet long, if the net pressure in the cylinder at a point a little in advance of half stroke is 50 lbs. on the square inch, the thrust or pull of the piston rod will be about 9 tons, and the upward effort on the slide bars will be $\frac{9}{7} = 1.287$ tons nearly, but the lifting effort varies in amount continuously, and so we have introduced what many writers regard as a distinct factor of disturbance. It is worth while to consider whether it is or is not, because there is a principle involved. Let us take the case of an engine carried on six wheels, without a bogie. The load on each leading wheel is six tons, the weight of each wheel is, say, half a ton, including its spring, axle box, and half the axle; the total load is then 13 tons under the leading wheels.

Now it will be seen that any lifting effort exerted above the axle box can be resisted only by, in this case, six tons, the wheel, axle boxes, axle and springs, regarded as so much dead weight, remaining unaffected. There is then at each side of the engine six tons holding down the guide bar. The upward lift on the guide bar exerted by the cross head represents only, as we have seen, less than $1\frac{1}{3}$ of a ton, and would have no effect whatever as a disturbing force were it not for the fact that the external disturbing forces come into play and prepare the way, so to speak, for this particular factor. We have already referred to the "rolling" of an engine. Experiments made some years ago in France have shown that an engine may roll so much that the whole of the load is taken off the leading springs and axle box at one side first and then the other, and the wheels kept the track only because of their own weight. It appears again that when an engine is running round a curve the centrifugal effort may take a very large percentage of weight off the inside wheel. In that case, again, the slide-bar thrust might be very much felt, tending to exaggerate rolling, and so promoting unsteadiness. When a bogie is used the conditions are somewhat different—

rolling has little or no effect on the bogie-wheel loads. Indeed, one of the advantages of the bogie is that it is exempt from the influence of internal disturbing forces up to a certain point, which will be considered presently. On the whole, then, although it is right to include cross-head thrust as an internal disturbing factor, care must be taken not to exaggerate an importance which is under any circumstances small.¹

¹ On the London and South Western Railway certain locomotives were many years ago built by Mr. Beattie. They were six-wheeled four-coupled outside cylinder engines; all the wheels had inside bearings. They rolled so much that outside bearings were put on the leading axles, and the springs were fitted under the lower guide bars, as there was nowhere else to put them. The expedient was quite successful.

CHAPTER IX

COUNTER-BALANCING

WE have now to consider a much more important source of disturbance than any named yet.

When a body of any shape revolves, it tends to turn round its centre of gravity. Rankine has put this fact so admirably that the author cannot do better than quote from the treatise "On the Steam Engine and other Prime Movers," page 27, second edition, 1861: "The whole centrifugal force of a body of any figure, or of a system of connected bodies, rotating about an axis is the same in amount and direction as if the whole mass were concentrated at the centre of gravity of the system. When the axis of rotation traverses the centre of gravity of the body or system, the amount of the centrifugal force is nothing, that is to say, the rotating body does not tend to pull its axis as a whole out of place. The centrifugal forces exerted by the various rotating pieces of a machine against the bearings of their axles are to be taken into account in determining the lateral pressures which cause friction, and the strength of the axles and framework. As these centrifugal forces cause increased friction and stress, and sometimes also by reason of their continual change of directions produce detrimental or dangerous vibration, it is desirable to reduce them to the smallest possible amount; and for that purpose, unless there is some special reason to the contrary, the axis of rotation of every piece which rotates rapidly ought to traverse the centre of gravity, that the resultant centrifugal force may be nothing. It is not, however, sufficient to annul the effect of centrifugal force that there should be no tendency to shift the axis as a whole; there should also be no tendency to turn it into a new angular position. To show, by the simplest

possible example, that the latter tendency may exist without the former, let the axis of rotation of the system, shown in Fig. 36, be the centre line of an axle revolving in brasses at E and F. At B and D let two arms project perpendicularly to that axle in opposite directions in the same plane, carrying at their extremities two heavy bodies H and C. Let the weight of the arms be insensible as compared with the weights of those bodies; and let the weight of the bodies be inversely as their distances from the axis; that is, let $H \cdot \overline{HB} = C \cdot \overline{CD}$, let H C be a straight line joining the centres of gravity of H and C and cutting the axis in G; then G is the common centre of gravity of H and C, and being in the axis the resulting centrifugal force is nothing. In other words, let a be the angular velocity of the rotation, then the centrifugal force exerted

on the axis by H = $\frac{a^2 H \cdot \overline{HB}}{g}$; the centrifugal force exerted

on the axis by C = $\frac{a^2 C \cdot \overline{CD}}{g}$, and these forces are equal in

magnitude and opposite in direction, so that there is no tendency to remove the point G in any direction. There is, however, a tendency to turn the axis about the point G, being the product of the common magnitude of the couple of centrifugal forces above stated into their leverage; that is the perpendicular distance \overline{BD} , between their lines of action. That product is called the 'moment of the centrifugal couple'; and is represented by $Q \cdot \overline{BD}$, Q being the common magnitude of the equal and opposite centrifugal forces. That couple causes a couple of equal and opposite pressures of the journals of the axle against their bearings at E and F, in the directions represented by the arrows; and of the magnitude given by the formula

$Q \cdot \frac{\overline{BD}}{\overline{EF}}$. These pressures continually change their directions

as the bodies A and C revolve; and they are resisted by the strength and rigidity of the bearings and frame. It is desirable when practicable to reduce them to nothing, and for that purpose the points B, G and D should coincide, in which case

the centre line of the axle E F is said to be a permanent axis."

The meaning of this passage should be fully mastered by the student ; what follows is based on it.

In the locomotive engine we have a crank axle, and it is quite clear that that axle is out of balance ; or if we take a pair of driving wheels mounted on a straight axle, these alone will be out of balance because of the crank pins.

Let us picture to ourselves a crank shaft caused to revolve in a lathe between the centres, and it will be seen at once that the conditions resemble those laid down by Rankine, and that not only will the axle tend to revolve round a centre of gravity, but about two centres, one proper to each crank ; the consequence is that a peculiar "wobbling" motion would take place unless the bearings held it steady, and that then the bearings would have thrusts and pulls to withstand which would vary in magnitude as the square of the number of revolutions made per minute.

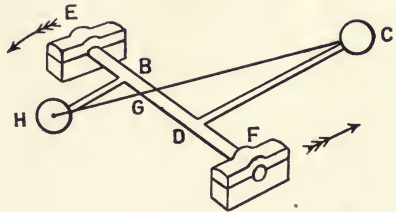

FIG. 36.—Centrifugal couples.

At first sight it seems to be enough to balance the crank, say by back-weights, as is done in marine engines, and indeed in some locomotives, but this will not suffice. The forces to be balanced are much greater than that due to the weight of the crank.

We have the piston rod and cross head moving in a straight line, and the connecting rod, each portion of which describes a path varying from a straight line to a circle, according to its position in the length of the rod. Now the piston rod, &c., have momentum and inertia. It is not necessary to go here into the mathematics of the problem in detail.¹ It is enough to say that Mr. Arthur Rigg, in his treatise on the steam engine,

¹ Those readers who may wish to see the problem treated mathematically cannot do better than consult a paper, "The Counter Balancing of Locomotive Engines," by Edmund Lewis Hill, read and discussed at a meeting of students of the Institution of Civil Engineers, January 30, 1891.

showed, it is believed for the first time, that the influence of the reciprocating masses of a steam engine may all be dealt with as though the weights were concentrated at the centre of the crank pin. Their effect is to cause the crank axle to try to revolve round a centre which is not identical with its mechanical centre; and taking four positions only for illustration, to make the crank axle bearing push forward, accelerating the engine; push backward, retarding the engine; push downward, augmenting the apparent weight on the rail; and push upward, reducing the load on the rail.

It must be steadily kept in mind that we have two disturbing forces to deal with, first the weight of the crank cheeks, pins, and eccentrics. This can be dealt with by putting balance weights on the wheel bosses or inside the rims; and inasmuch as these weights would be symmetrically outside the cranks, and the cranks would be symmetrically inside them, the common centre of gravity would fall about the middle of the length of the crank axle, and there would be no centrifugal couple produced, and the axle would revolve harmoniously in its bearings. Balancing of this kind is very old. Among the first engines built by Bury, Curtis and Kennedy, the wheels were made of cast iron with wrought iron tubular spokes; the bosses had balance weights cast on them. The second disturbing force is the momentum and inertia of the piston, cross head, piston rod, and connecting rod. The effect of these factors on any high-speed engine is well known. Their effect on a locomotive is usually made the subject of rather abstruse mathematical investigation. For instance, Makinson, on "The Internal Disturbing Forces in a Locomotive," a paper which was read before the Institution of Civil Engineers, which will be found in vol. ccii. of the Transactions, page 106, may be cited, or Mr. Hill's paper, already quoted. Happily the whole problem admits of being stated in general terms with quite sufficient accuracy for ordinary purposes. Although the parts move in straight lines and ovals they can be treated, as has just been said, as if they revolved round the centre of the crank axle; thus in the accompanying diagram, Fig. 37, we have a crank

axle A, a crank B, and a crank pin C. Now the effort of a piston, connecting rod, &c., may be regarded as the same as that which would be produced if a symmetrical ring D, equal to the reciprocating portions in mass, that is to say, in weight, surrounded the crank pin. This simplifies the matter enormously. Thus, let us suppose that the total weight of the reciprocating parts is 500 lbs., that the engine has 6-foot driving wheels, and runs at sixty miles an hour. Then the speed of the crank which is one foot long, as regards the engine is 29.3 feet per second, and by the rules already given the centrifugal effort or "force," as Rankine calls it, will be, in round numbers, nearly six tons. When the crank is horizontally forward the axle is forced against the axle box, urging the engine onward; and when the crank is horizontally pointing backwards, then the engine is retarded by a similar amount. To understand what really takes place, let us consider the piston at the termination of the forward stroke. It has to be made to move backward at once with a velocity accelerated from nothing to about 1,000 feet per minute, and the crank has to drag the piston away from the end of the cylinder. In the same way, when acceleration ceases about mid-stroke, the piston, &c., pushes on the crank which has to retard it and bring it to rest. The amount of push and pull will be modified by the pressure of the steam in the cylinder in a way sufficiently obvious.

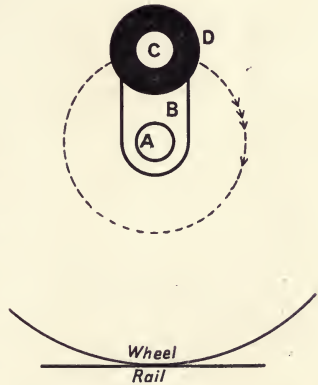

FIG. 37.—Rigg's diagram.

It will be seen now that after all allowances have been made we have very serious disturbing forces to deal with. The general result of the combination is to make the engine move by jumps instead of going steadily forward, and inasmuch as the influence of want of balance is not symmetrical, because the cranks are not opposite each other, but at angles of 90 degrees, the whole effect on the engine is to set up a violent fore and aft oscillating

movement, which is not only objectionable and even dangerous, but inimical to speed. Although much was done in a rule of thumb way before D. K. Clark took the subject up, it may be safely said that he was the first to introduce the systematic use of balance weights in the driving wheels of locomotives, and this he did after many experiments, putting, in 1856, balance weights into the driving wheels of the *Canute* on the London and South Western Railway. The engine had already had the dead weights balanced by 85 lbs. bolted inside the rims of the driving wheels. Mr. Clark added 186 lbs. for each wheel. "The engine runs so much more steadily and freely with the new balance weights as to take the engine men by surprise. On the first day after the alteration, the stations were considerably overshot by the engine, although steam was shut off and the brakes applied at the usual distance from the stations. The saving in fuel by the improving of the counterweights of the engine was estimated at 20 per cent."

It must be kept carefully in mind that balance weights¹ are used for two purposes—in the first place, to deal with dead weights; in the second place, to deal with the forces due to the reciprocation of the moving parts. Now it so happens that the useful action of these latter compensating weights is limited to a portion of each revolution, while centrifugal force is constant all through each revolution. The consequence is that the weights put in to deal with reciprocating masses are superfluous for large portions of each revolution, and they are not only superfluous, but mischievous. What we want in any case is not their centrifugal energy, but their momentum, which is quite a different thing.

Thus their centrifugal effort when they are at the top of the wheel tends to lift the wheel off the rail, and again when it is at

¹ The words "balance weights" are misleading. We have the small weights necessary to balance the rotating masses, and properly so called; but the remaining and much larger weights are not intended to "balance" anything; they are really compensating weights intended to neutralise the effect of momentum and inertia in the reciprocating masses on the rest of the engine; thus when a piston is flying backward the compensating weight is flying forwards.

the bottom it tends to force the wheel down on the rail: the result of the first is to tend to cause slipping; the result of the second is what is known as "hammer blow," very destructive to the rail. To reduce the mischief as much as possible in practice the custom is to balance all revolving weights and only three-fourths of the reciprocating weights with inside cylinder engines. With outside cylinder engines the balancing is a little more complete, the moving parts being generally lighter. The result is that the inertia and momentum of the reciprocating parts are not quite compensated, but, on the other hand, the mischief done by centrifugal effort is reduced; and indeed complete compensation is not necessary, because compression at the beginning of each stroke tends to bring the piston quietly to rest, and lead—that is, the admission of steam before the crank reaches the dead point—helps the piston away from the end of the cylinder. While on the whole compensation is quite satisfactory, it must not be forgotten that it is bought at a price; centrifugal force comes in as a factor which would be gladly spared, and has indeed been eliminated in a way which will be explained further on.

The balance weights usually take the form of the new moon. The reason why will be explained when the locomotive as a steam engine is considered.

In former practice the cast iron balance weights were placed between the spokes just under the rim and secured by two flat wrought iron segmental plates riveted through the cast iron, one outside, the other inside. In modern engines they form part of the steel wheel centre, being cast with it. Sometimes they are hollow and lead is poured into them so that precisely the proper weight can be provided. For reasons which cannot be explained here, in some cases the centre of gravity of the weight is not diametrically opposite to the cranks; in others it is divided. Thus the cranks are balanced by "back weights" as in marine engines, which are in effect prolongations of the crank cheek backwards. Again, the coupling rods have to be taken into account. Obviously they balance some of the weight. But their presence introduces further complications. Several

designers divide the balance and compensating weights among all the driving wheels, contending that in this way hammer blow is minimised. But generally only the weight of half the side rod and the crank pin is balanced in a coupled wheel.

Although compensation and balance weights are always provided, and rightly so, as if they described circular paths, it must be remembered that they only do this as regards the engine. Their true path in space is a cycloid, and this as regards the rail has, it is held by some engineers, an effect on the relations between wheel and rail. Thus they point out that the effect of hammer blow does not take place immediately under the balance weight, but before it has reached the rail. Experiments show that the place of what may be termed impact varies with the speed and other conditions, so that it is by no means easy to say what is really the best angle with the cranks at which to fix the weights. Mathematical investigations have not given results which necessarily coincide with those obtained in practice. There is in consequence no such thing as absolute uniformity; and balancing and compensating are carried out very much in the way that experience has shown to give the smoothest running engine without much regard to theory.

In the United States the effect of hammer blow has received far more consideration than in this country. Rails are not made with the same care as in Great Britain, and a sharp controversy has gone on between the locomotive superintendents and the rail makers, the latter asserting that it is hammer blow that splits and breaks the rails.

In order to supply some information on the subject a number of experiments were carried out on the testing plant of the Pennsylvania Railway at the St. Louis Exhibition. It will be remembered perhaps that this testing plant consisted essentially of a set of wheels, the distances between which could be adjusted, and fitted with very powerful dynamometer brakes. The engine to be tested was run into the shed, and its wheels were supported on the brake wheels which revolved when the driving wheels turned. The locomotive was prevented from running off the brake wheels by its draw bar, which was secured to a

tractometer, the other end of which was secured to a strong anchorage. This plant was in the main a reproduction of that designed by Professor Goss for the Purdue University. A very similar plant has now been in use for nearly two years at the Great Western Railway Works, Swindon.

In order to settle what the effect of the balance weights might be, Professor Goss, by whom the experiments were carried out, adopted the ingenious expedient illustrated in the accompanying

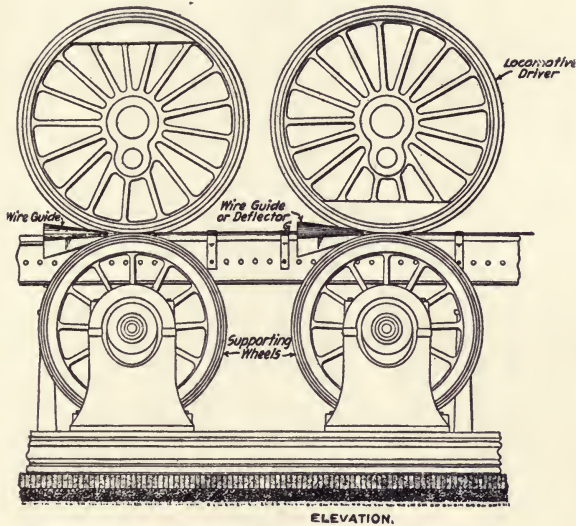

FIG. 38.—Wire test for hammer blow.

engraving, Fig. 38. Annealed steel wires $\cdot 06$ inch in diameter were passed between the driving and the brake wheels, and subsequently measured with a micrometer calliper at intervals of 5 inches. Guide pipes $\frac{3}{8}$ inch in diameter were used to lead the wires to the point of contact between the wheels. Before being used the wires were carefully straightened, cut to lengths 3 feet greater than the circumference of the driving wheel, and rubbed bright with emery cloth. Behind the points of contact of the driving and supporting wheels were galvanised iron cones placed

to throw the wires away from the machinery after passing the wheels. A small groove was cut across the driving-wheel tire in the same plane and on the same side of the wheel as the outside crank pin. This gave a reference mark on the wires so that the wheel positions could be determined. It would be impossible to go into a consideration of the results obtained at any length. The conclusions of the most interest reached by Professor Goss are that wheels balanced according to the usual rules, which require all revolving parts, and from 40 to 80 per cent. of all reciprocating parts, to be balanced—this latter portion being equally distributed among the wheels coupled—are not likely to jump the track through the influence of the weight. Where a wheel is lifted through the action of its balance weight its rise is comparatively slow and its descent rapid. The maximum lift occurs after the counterbalance has passed its highest point. The rocking of the engine on its springs may assist or oppose the action of the counterbalance in lifting the wheel. It therefore constitutes a serious obstacle in the way of any study of the precise movements of the wheel. The contact of the moving wheel with the rail is not continuous even for those portions of the revolution where the pressure is greatest, but is a rapid succession of impacts. There is reason, however, to believe that the lifting does not affect the wheel as a whole, but is the result of vibration, which in its turn is a consequence of the elasticity of the metals concerned, namely, the surface of the tire and the rail.

These experiments go to show that the received theory that a driving wheel rolls quietly on a rail with an insistent pressure varying rhythmically throughout each revolution is not quite consistent with the facts, the phenomena of the relations of wheel and rail being complex instead of simple.

The reader has, it is believed, been now placed in possession of the principal facts concerning the locomotive as a vehicle. He has seen something of the forces to which it is subjected, and of the methods adopted in dealing with them. But it must be carefully kept in mind, particularly by the student, that the mathematical inwardness of the subject remains for his

consideration, and that even the observed facts have not been completely set forth. Thus, for example, the influence of elasticity in the roads on the locomotive has not been considered, and yet elasticity is a thing that has to be carefully provided in permanent way. For reasons already stated, and indeed restated, a complete consideration of the locomotive as a vehicle would be out of place in this volume.

SECTION II

THE LOCOMOTIVE AS A STEAM GENERATOR.

CHAPTER X

THE BOILER

It is probable that as many as fifty different types of locomotives are at work to-day on the railways of the world. If we except a small number of motor railway coaches, which have vertical boilers, all have boilers presenting the same general features. We have at one end a box with a round or flat top, at the other end another box with a chimney set on top of it, and the two boxes are connected by a cylindrical barrel. It will be seen at once that the form and arrangement lend themselves admirably to being carried on wheels. We have only to look at a locomotive and try to adapt a vertical or rectangular boiler to the engine framing and wheels to arrive at the obvious conclusion that it is not possible to improve on the general design. In fact, the external characteristics of the locomotive may be said to have been fixed for us by conditions which cannot be altered; and that is the reason why, notwithstanding the many attempts which have been made to modify the external characteristics of the locomotive, they remain in the main what they were to begin with.

As this book is not historical, it will be enough to say that from the day when George Stephenson ran the *Rocket* at the Rainhill competition on October 6, 1829, to this moment, the locomotive boiler has remained unaltered in principle, and this notwithstanding the fact that various modifications have been

proposed and tried. The locomotive engine boiler will therefore be dealt with as it is and not as it might be.

We have, as has been said above, at one end a rectangular box with a flat or circular top. Inside the box is placed another made of copper, or of steel plates, with a space between the two boxes which is filled with water. The first, or external fire-box, is riveted to a cylindrical "shell" or "barrel." To the other end of the shell is secured the smoke-box; the internal fire-box is united to the smoke-box by a great number of tubes about 2 inches in diameter. The boiler is filled with water to such a height as will drown the fire-box and the tubes. A

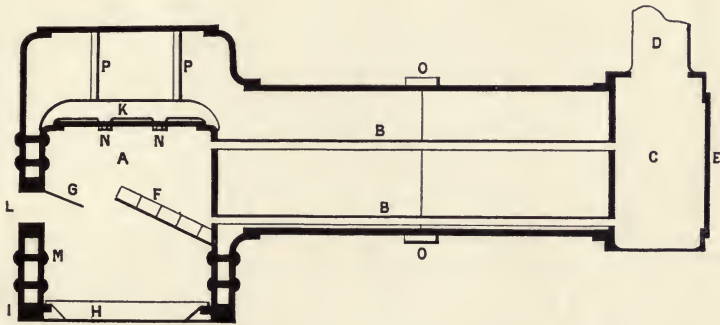

FIG. 39.—Sectional diagram of boiler.

grate is fixed in the bottom of the fire-box, and a fire being lighted on it, the smoke and gas pass from the fire through the small tubes and into the smoke-box, and thence up the chimney. The heat is communicated to the water through the walls and roof of the fire-box, and the metal of the tubes. What is left goes to waste up the chimney. The accompanying diagram, Fig. 39, shows a locomotive boiler in section. Here A is the internal fire-box. B B are two of the flue tubes and C the smoke-box, D the chimney, E a door giving access to C. A brick arch is shown at F and a deflector at G to beat down the air entering through the fire door on to the burning coal. H is the grate, I the foundation ring, K bridge stays, sometimes reinforced by sling stays P P, L is the fire door, M screwed stays.

Before considering in detail the construction of a boiler, it will be necessary to say something of what goes on inside it, because it is this that settles the interior characteristics of the boiler, just as the fact that a locomotive engine is a comparatively long narrow vehicle has settled its external appearance.

The first thing to be done is to burn coal; the second to absorb the heat given off during the process, and use it to make steam. What is subsequently done with the steam will be discussed when we come to deal with the locomotive as a steam engine. It has been dealt with as a vehicle. It is now to be dealt with as a means of turning water into steam.

It is a curious truth that in this extremely scientific age next to nothing is known concerning the conversion of any liquid into a vapour or gas. The whole literature of the subject is represented by two or three pages of Ganot's "Physics." The question is much too large to handle adequately here, but it cannot well be passed over when we bear in mind that the durability of a boiler, its safety from explosion, and the good and bad qualities of the steam, are all matters of the utmost importance, presenting problems which depend for their solution on a knowledge of how steam is made to the best advantage and what it really is.

The received theory is that steam while in the saturated state, that is, with no free heat, is nothing more than water with its molecules driven asunder by heat. When steam is superheated, it becomes a gas like air, that is all. As an apt expression of the received concept of the formation of vapours—steam and gas—nothing can be better than the following extract from an article by Mons. L. Houllevigue in the *Revue de Paris*, of April 1, 1903, translated by Chief Engineer B. F. Isherwood, United States Navy, for the *Journal of the Franklin Institute*.

"Physicists saw matter formed of molecules or aggregated molecules isolated from each other and pursuing each other in incessant movement like the particles of dust vibrating in the sunbeam, and from this eddying mass they saw escaping waves, that propagated themselves in space by means of an infinitely rare medium, which was to the lightest of known bodies, hydrogen, what the density of hydrogen was to the density of the heaviest

metals. Gases, especially, appeared as microscopic projectiles darting in every direction and continually bombarding, without loss of force, the sides of the vessel that contained them, only to rebound again and recommence their eternal movement. The heat contained in the gases took from similar impacts a more precise significance; it showed the present energy of all these moving corpuscles. If the gas be cooled, the velocity of the projectiles diminishes, their trajectories flatten, then all the corpuscles collapse, but still retain eddying movements; this is liquefaction. Then, in measure as more and more energy is taken out of them, the vibrating molecules make less and less extended movements, and the liquid contracts in cooling. Very soon the increasing nearness of the molecules to each other enables them to make among themselves new interactions, their relative positions become nearly invariable, and the liquid solidifies; but the resulting solid is still animated with life-like shiverings; it could still be cooled down to the point at which its molecules would repose, inert, one upon the other; and then the matter would be dead."

Here we have the whole process of the conversion of, say, ice into superheated steam stated in inverse order.

Man produces more steam than any other manufactured article. It is quite impossible to ascertain with certainty what weight of coal is burned annually in making steam for the factories, mines, railways and ships of Great Britain. There is, however, reason to believe that not short of 60,000,000 of tons. Allowing that each ton of coal will make seven tons of steam, we have then an annual output of no less than 420,000,000 of tons of steam for this country alone, or forty-two times the weight of iron we make. All this is manufactured by the aid of costly apparatus, and with a certain amount of risk of life, limb and property.

Allowing 35 cubic feet to the ton, the water converted into steam, as stated above, would amount to 14,700,000,000 cubic feet, which would fill a lake 100 feet deep and over $2\frac{1}{2}$ miles long and 2 miles wide. The quantities are stupendous, yet, as has just been said, next to nothing is known of the nature of the material, steam. The author is quite prepared to find this statement

treated with incredulity. It will be said that everything is known, that the literature of the subject is profound and practically complete. These statements, however, it will be found on examination, apply not to steam, but to the apparatus by which it is made, namely, boilers and furnaces; and to that by which it is used, namely, engines. If nothing had ever been written about iron but treatises on the blast furnace, the converter, the mill and the cupola, no one would say that the literature of iron and steel was complete. Let us draw an analogy between the blast furnace and the steam boiler. Into the first we put coke and ore and limestone and air, and out of it we get pig-iron and gas. Every step of the process by which the iron and gas are obtained has been made the subject of careful inquiry. Into a boiler we put water and we take out steam. But of the inwardness of the process practically nothing is known. Things are taken for granted, and when phenomena present themselves out of the common we are told either that they have no real existence, that they are quite usual, or that it is not worth while to pursue an inquiry. A great deal has been written about the conductivity of boiler plates, to name one thing, but no one cares to inquire how or why the heat is passed into the water, or what it does when it gets in.

The accepted explanation advanced by scientific men has been given above. Somewhat different views have recently been advanced by physicists in the first flight of scientific research; but these do not admit of being briefly stated, and their extended consideration would be out of place in this book.

Descending from the more or less transcendental region of pure thermodynamics to practice, let us consider how the heat generated by the combustion of fuel and imparted to the water is distributed. In other words, to crystallise our ideas the facts must be stated quantitatively. This has never been done in more detail or more lucidly than by Benjamin Isherwood in his splendid "Researches in Steam Engineering." For convenience of reference his table has been reproduced on the next page. It will be seen that he has used the old thermal unit 772 instead of the modern unit 774, but the difference is of no importance, and

some uncertainty even now exists as to the precise foot-pound value of the heat required to raise one pound of water 1° F. Incidentally it may be pointed out that minute and precise as Isherwood's statement is, it gives no clue, and pretends to give no clue, to the way in which water is converted into steam. At first

Distribution of heat in the conversion of 1 lb. of water at 32° F. into steam at 212° F.		H Thermal units. $D \div 772.$	D Dynamical Equivalents. $H \times 772.$	Per cent. of total Heat.
Total heat of steam of 212° from water at 32°		1,146·600	885,175·200	100·000
Heat in water.	{ Increasing the temperature of the water from 32° to 212° and lessening the cohesion of the water between 32° and 212°	180·898	139,653,359	15·776
	{ Increasing the volume of water between 32° \times 212°	0·0018	1·4406	0·0002
Heat in steam.	{ Destroying the cohesion of the water (<i>i.e.</i> , converting it into steam from the boiling point)	893,666	689,910,025	77·940
	{ Increasing the volume of the water from that which it had as water at 212° to that which it had as steam at 212°	72·0341	55,610,374	6·2820
		1,146·600	885,175·200	100·000

sight it may appear that if we really understood all about it, the fact would have no practical value, but this is not the case. There are peculiarities in the performance of different locomotives which await explanation. There are explosions, such as that at St. Lazare, in Paris,¹ that remain wrapped in mystery; and it

¹ On the 4th of July, 1904, at 11 a.m., the boiler of engine No. 626, at the time standing in a cutting outside St. Lazare Terminus of the Western Railway of France, exploded with extraordinary violence. It was literally

seems to be by no means impossible that if we possessed more knowledge, improvements of real value might be introduced in our methods of making steam. As the reader proceeds, it is hoped that the relation between what has just been read and the facts of the everyday life of the locomotive engine may become more apparent than they are for the moment.

blown to bits, the fragments, some of them very small, being projected to great distances, falling in the neighbouring streets. No one was killed, though a few people were hurt by falling glass and flying gravel. The damage to property was estimated at £80,000. At first it was believed that Anarchists had put a bomb in the fire-box, as there was no one on the foot-plate at the time. The theory was untenable, and three special independent inquiries were carried out. Each reached a different conclusion. To this day the explosion remains unexplained. The interested reader will do well to consult the "Bulletin de la Société d'Encouragement" for July 31st, 1905, where he will find complete details and illustrations.

CHAPTER XI

THE CONSTRUCTION OF THE BOILER

WE may now proceed to consider in detail the construction of the locomotive boiler. No better boilers are made than those produced in Great Britain and Ireland. The railway companies take care that the material and workmanship of the boilers made in their own shops shall be the best possible; and the splendid reputation possessed by our locomotive engine building firms all over the world is sufficient testimony as to what they can do.

We have to do, in the first place, with the stresses to which a boiler is exposed. The simplest case is that presented by the barrel or cylindrical shell. In calculating the stress, the curved area of the plates is to be treated as though it was flat, as shown in the accompanying diagram, Fig. 40, wherein the dotted line shows the shell as it is and the two full lines the areas giving the stress. Let us suppose that the shell is 48 inches in diameter and that it is divided up into rings each one inch long. Then the area we require is 48 square inches, and the effort of the pressure, 100 lbs. per square inch, tending to separate the halves of the boiler, is 4,800 lbs. on each inch of its length. Now the effort may be supposed to be concentrated at the point C in each section, and is, of course, resisted by two thicknesses of the shell, one above, D, the other below, E. Let the plates be half an inch thick; then the sectional area to carry the pressure will be one inch, and the stress per square inch of section of the shell plates will be 4,800 lbs., or a little over two tons. The total bursting stress in a large modern boiler, with a barrel 14 feet

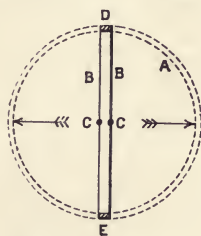

FIG. 40.—Radial stress.

long and 5 feet in diameter, carrying 220 lbs., is in round numbers 900 tons. If the plates are half-inch thick, then the stress will be 13,200 lbs., or approximately 6 tons per square inch of sectional area.

The facts have been stated in this elementary way, because many persons, students especially, find some difficulty in understanding how radial pressures act, and are disposed to think that the whole surface should be taken into consideration.¹

The formulæ for calculating bursting pressures are, of course, very simple. They will be found in most treatises on steam boilers and various text-books.

Let d = the diameter of the boiler in inches; t = the thickness of the plate in inches; s = the ultimate strength of the metal in tons per square inch; and p the pressure in pounds per square inch.

Then $d p$ is the total pressure on a 1-inch length of both sides together; $2 t$ is the sectional area of both sides; and $2 t s \times 2,240 = d p$.

$$\text{Then } p = \frac{4,480 t s}{d}; \quad t = \frac{d p}{4,480 s^1} \text{ and } s = \frac{d p}{4,480 t}$$

It must not be forgotten, however, that a boiler shell is not made up of solid plates, but of rings riveted together, and as no riveted joint, no matter how made, can be as strong as the solid plate, a deduction must be made. That is to say, the tensile strength of the solid plate must be multiplied by the fraction co-efficient proper to the system of riveting employed. Thus, the joint may be single or double riveted, or it may have a single butt strap, or two butt straps, one inside, the other out. In the diagram, Fig. 39, at O a single butt strap is shown. In a general way it may be taken that the strength of a single riveted joint is 56 per cent. of that of the solid plate, while a double riveted joint has a co-efficient of about 78 per cent.; but there are various qualifications depending on the way in which

¹ Some years ago an inventor, reasoning in this way, took out a patent for a corrugated piston, the expanded surface of which would be much greater than that of a plane piston. The advantage to be gained he explained with some care.

the rivet holes are made. The Board of Trade rules for marine boilers go most elaborately into the question. The following formulæ are quoted from the rules as laid down in Trail's "Hand-book for the Guidance of Engineers, Surveyors and Draughtsmen," written in 1888. Certain modifications have been made since, which, however, do not affect the formulæ. If the plates and the rivets and the workmanship comply with the stipulations laid down, then the percentage of strength of any joint or other particulars of the joint may be found by the following formula:—

p = pitch of rivets in inches.

d = diameter of rivets in inches.

A = area of one rivet in square inches.

n = number of rivets in one piston (greatest pitch).

% = percentage of plate left between rivets of greatest pitch.

% = percentage of rivet section as compared with solid plate.

% = percentage of combined plate and rivet section when the number of rivets in the second row is twice that in the outer row.

c = 1 for lap or single butt-strap joint.

c^1 = 1.75 for double butt-strap joint.

T = Thickness of plate in inches.

Then to find the percentage strength of any given joint:—

$$\frac{100 (p d)}{p} = \% \quad (1)$$

$$\frac{100 \times 23 \times A \times n \times c}{28 \times p \times T} = \% 1. \quad (2)$$

Fortunately the Board of Trade has nothing to do with locomotive boilers. If they were made in conformity with the formula given above they would be very much heavier than they are. A very large factor of safety is provided mainly because of the corrosion which takes place at sea, and not on land. The locomotive boiler again does not work for weeks at a time without examination. The boiler is under constant supervision, and the most watchful care is exerted to secure immunity from explosion. The result is that scantling can be reduced without risk in a way that would not be admissible at sea. But the Board of Trade

rules have been given here because they are of general value as guides to those engaged in the designs of any boilers, locomotive, marine or stationary, which have riveted joints.

The boiler barrel is made up of two or three rings according to its length. The plates are cut to the proper length, and their edges are planed. They are then bent between three rolls until the ends of each plate meet, and they are secured together by two butt straps, one inside, the other out, double riveted. In some cases the rings are secured end to end by narrow hoops and a double row of rivets for each hoop. The whole inside of the barrel is then flush from end to end. In other cases the rings are telescopic; that is to say, each is pushed about 3 inches into the one behind it, the largest ring being next the fire-box. This is a good plan, because it increases the water space next the fire-box. There are two or three methods of securing the barrel to the fire-box, but a minute description of these would be out of place here.

So far no one has yet had the courage to risk welding longitudinal seams. Flues for stationary and marine boilers are now almost always welded. But the stress being external tends not to open, but to close their seams. The circumferential seams are exposed to precisely one half the stress, the longitudinal strength of a tube with closed ends being to the circumferential strength as two to one. To make this quite clear, let us suppose a tube 8 inches in diameter, the sectional area of which is 50 square inches; the pressure inside is 100 lbs. on the square inch. Then we have $100 \times 50 = 5,000$ lbs. tending to pull the tube asunder endways. The circumference of the tube is (omitting fractions) 25 inches. The thickness of the plate is 0.5 inches. Then the sectional area of metal resisting the stress is $\frac{25}{2} = 12.5$ square inches. The bursting stress for length = 1 inch = 800 lbs., and the area of metal to sustain it is one inch. But the longitudinal effort is 5,000 and $\frac{5,000}{12.5} = 400$, or just one half the bursting stress.

We come next to the flat surfaces of the inside and outside

fire-boxes, and the staying of these constitutes the most important structural problem that has to be solved by the locomotive superintendent. No part of the complete machine gives so much trouble or causes so much anxiety as the boiler, and it is not too much to say that 90 per cent. of this is due to the fire-box. The nature of these troubles will be considered in some detail before any attempt is made to explain the special means taken to elude or otherwise get over them. Take, for instance, an internal fire-box which is 6 feet long, 5 feet deep, and 3.25 feet wide. The area of the flat crown of this box is, in inches, $72 \text{ by } 39 = 2,808$.¹ Let the pressure be 200 lbs., then $2,808 \text{ by } 200 = 561,600 \text{ lbs.}$, or 250 tons. Each side has an area of $72 \text{ by } 60 = 4,320$ square inches and $4,320 \text{ by } 200 = 864,000 \text{ lbs.}$, or more than 385 tons. How many persons realise as they stand beside a locomotive that stresses so enormous represent the effort of the steam to escape? 900 tons to rip the shell open; 385 tons to force out the flat side of the fire box; 250 tons to drive the fire-box down on the rails, and blow the rest of the boiler through the station roof. Is it wonderful that the boiler of a locomotive should claim and get from day to day more attention than any other part of the machine?

We have now to consider how these enormous stresses are carried. In the barrel they only put the metal in tension, and being quite simple they can be dealt with easily enough. It suffices to provide a sufficient section of metal and adequate riveting. It is far different with the flat surfaces. There is so far as the vertical portions of the fire-box are concerned, only one method of support available, namely, tying the plates to each other by stay bolts, and tying the front plate of the fire-box to the plate at the leading or smoke-box end of the barrel. There are two methods in use for supporting the top or crown of the fire-box: first, screwed stays attach it to the top of the outside fire-box; secondly, girders are placed on the top of the inside box, to which it is secured by screwed bolts. Both these systems are illustrated.

¹ This is virtual area, being that of the rectangle formed by the foundation ring. The top of the fire-box is almost always wider than this.

Numerous experiments have been made to ascertain the pressures that flat plates of iron, steel and copper will sustain when supported by screwed stays. The results, however, of practice—in other words, those obtained in the regular performance of their work by locomotives—have resulted in the almost universal spacing of stay bolts 4 inches apart, centre to centre, the bolts being $\frac{7}{8}$ inch diameter. Now these bolts are an endless source of trouble, expense and even danger. They are short, the distance between the two plates stayed varying from $2\frac{1}{2}$ inches as a minimum to 4 inches as a maximum. The inside fire-box being of copper, which has a co-efficient of expansion of $\cdot 1722$, while the outer box is of steel with a co-efficient of $\cdot 1145$, and the inner box being besides always hotter than the outer when the fire is alight, it follows that the inside box rises inside the outer box, it may be by as much as 0.25 inch. This cannot take place without bending the stay bolts, or the plates in which they are set; and inasmuch as this tendency does not take place once for all, but goes on continuously as the temperature of the furnace varies, in time the stays become “fatigued” and break. The only ways of ascertaining whether they are broken or not is by sounding the heads with a hammer—by no means a certain test—or by finding a bulge in the plate. In some cases a hole about one-eighth of an inch in diameter is drilled down the centre from the outside of each stay, but not quite through. If the bolt breaks, water will escape violently through this hole. The breakage of a large number of stays at once has caused some frightful catastrophes, the engine often turning a somersault. Inventors have not been idle, and various patents have been taken out for imparting flexibility to the bolts. These as a rule contemplate a reduction in the sectional area of the bolt. One inventor cuts four slots longitudinally in the bolt. These are made with a small circular saw, and the slots are deeper in the middle than at either end. The ordinary practice is, however, to make the stays on the same principle as a Palliser armour-plate bolt, a principle involving so much and of such wide application that it claims some explanation here.

CHAPTER XII

STAY BOLTS

IN the early days of armour plating the targets consisted of beams to which the plates were fixed by bolts about 3 inches in diameter. The heads were tapered and counter-sunk into the plate. The screwed ends and the nuts, under which large washers were placed, were inside the ship's side, so to speak. When a projectile struck the plate a number of the nuts always flew off, the bolts breaking through the threads; and to say nothing of the mischief they were quite capable of doing among a crew, it was only necessary to hit a plate two or three times, and it would fall off altogether. Various attempts were made to get over this radical difficulty. Elastic washers were put under the nuts with indifferent results. Then Captain Palliser, an artillery officer, solved the problem by reducing the diameter of the bolts somewhere about the middle. A reduction in section, no matter how effected, had the same result. Thus boring holes down the centre of the bolts had the same effect as turning them down outside. This is the reason why the crank shafts and crank pins of marine engines are hollow. But this is not all. The effect of cutting a screw thread on a bolt is about the same as if it were nicked all round. Thus an armour plate bolt being screwed, would in effect be nicked, and would break generally just where the last thread of the screw joined the solid. Captain Palliser turned his bolts down in such a way that the screwed part was always "proud" of the rest of the bolt. Thus if the thread of a 3-inch bolt was one-fourth of an inch deep, then the body was turned down until it was something less than $2\frac{1}{2}$ inches in diameter. In most cases the fire-box stay bolts of locomotives are made in this way, but it is doubtful if an adequate return has

been obtained. The Palliser principle works to admiration in dealing with sudden stresses or shocks, but it does not appear to be equally efficacious when a bar under steady stress is bent frequently through very small angles. At all events, stay bolts are still prone to break; and it is held by many engineers that the best chance of success lies in providing a wide water space, which gives a long bolt, and making the bolts thicker. As much as $1\frac{1}{8}$ inch over the threads has been adopted with success. When a stay is renewed it is almost always necessary to enlarge and retap the holes, and then stays of $1\frac{1}{4}$ inch over the threads are put in. In the United States no stay bolts less than $\frac{7}{8}$ inch diameter are used in locomotive fire-boxes, and then only for 150 lbs. pressures. Both in the United States, in this country and on the Continent various materials have been tried. In America the preference is given to treble-refined iron, but then copper boxes are almost unknown in the United States, mild steel taking the place of the more expensive metal. In this country, although steel is used to a limited extent, it has not met with general favour, and the stay bolts are almost always of copper. Various bronzes have been tried, and for the lower rows of bolts bronze is still being used to some extent. Lately recourse has been had again to Bowling or Lowmoor Iron. The strength of a fire-box is largely dependent on the riveted heads of the stay bolts, and these are very liable to be worn away by the friction of the fuel against the sides of the box.

It is worth notice that although theoretically the bending stresses are the same at each end of the bolt, yet that it is usually at the inside of the outside plate that fracture occurs.

The pulling stresses on the bolts are very moderate. Each has to support an area of $4 \text{ by } 4 = 16$ square inches. With a pressure of 200 lbs., this gives 3,200 lbs. as the tension. If the bolt has been turned down to $\cdot601$ inches area and we take the ultimate strength of copper at 16 tons or 35,840 lbs. per square inch, then $35,840 \times \cdot601 = 21,600$ lbs. as the breaking strength of each bolt, and $\frac{21,600}{3,200} = 6\cdot4$ which is the factor of safety when the boiler is new. Apparently this is enough, but as it is

unquestionable that deterioration begins from the first day, few engineers regard it as sufficient, and for these higher pressures larger diameters or closer spacing is always adopted. Stays as much as $1\frac{1}{4}$ inches diameter spaced $3\frac{1}{2}$ inches centre to centre, have been used.

How long a stay bolt will last is a vexed question. According to some authorities, long before fracture is likely to take place, the rivet heads will have been worn off and the stay begin to leak. A great deal of this difference of opinion seems to be due to varieties in the quality of the coal used on different lines, methods of firing, and, above all, the characteristics of the metal of which the stay is made. An explosion which occurred on the Hull and Barnsley Railway last September is so instructive and bears so directly on what has just been said, that particulars of it may well find a place here. The three engravings, Figs. 41, 42, 43, show the construction of the fire-box and the effect of the explosion. The crown was supported by sling stays G G for about two-thirds of its length. Thence onward by three transverse bridge stays, E, the ends of which rested on angle irons riveted to the inside of the outer fire-box; the water spaces do not appear to have been more than $2\frac{1}{2}$ inches wide. The fire-box seems to have always given trouble, no matter for surprise when the great depth of the thin sheets of water at the sides of the box are considered. Fig. 44 is very instructive, showing as it does how the inside ends of the stays disappeared. The riveted heads first went, then leakage took place and caulking began, and the unfortunate stays had their ends beaten down in the plate until they lost their hold, and this took place in less than two years. The engine (a goods tank) was standing in a siding when, about 3 a.m., it exploded; the driver who was on the footplate was killed, the fireman who had gone to a signal box a little way off was not hurt. The Board of Trade report states that "The explosion was caused by the failure of a group of stays, about 30 in number, situated near the bottom of the left-hand side of the fire-box in the 2nd, 3rd, 4th, and 5th rows, counting from the bottom, the attachment of which to the copper plate had become most defective. The clenched heads of these

EXPLOSION FROM A LOCOMOTIVE BOILER ON THE HULL & BARNSELEY RAILWAY AT WATH.
THE DIAGONAL SHADING SHOWS THE PART OF THE FIREBOX TORN AWAY.

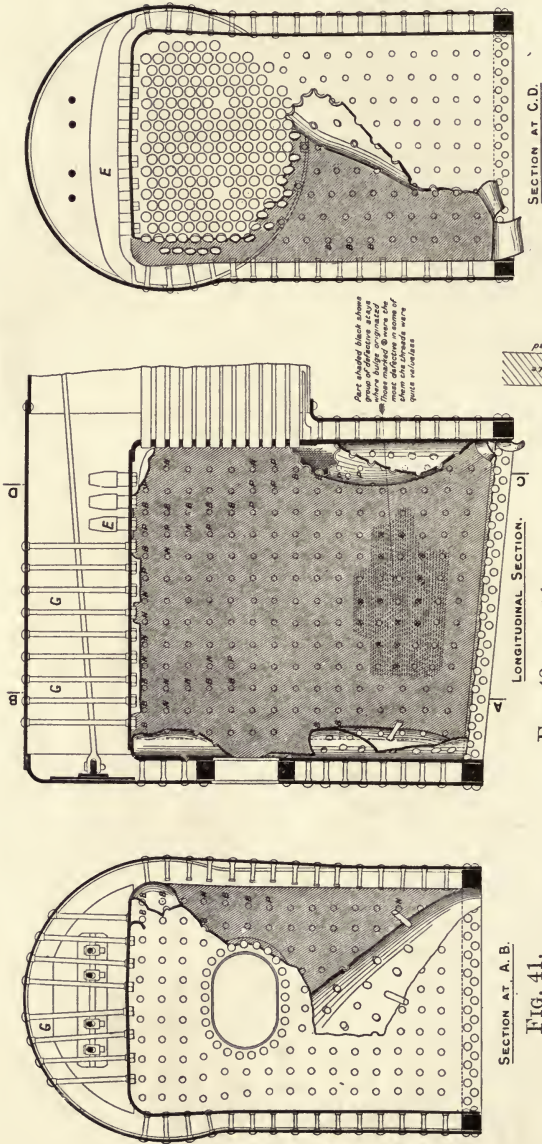

SECTION AT C.D.
FIG. 43.

LONGITUDINAL SECTION.
FIG. 42.

SECTION AT A.B.
FIG. 41.

Stays marked with letters dense broken ones. These marked K appear to be new fractures. Those marked B, old fractures, and those marked P were partly broken before the explosion occurred.

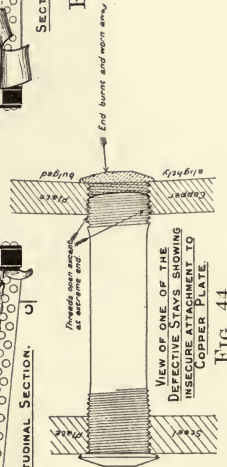

VIEW OF ONE OF THE DEFECTIVE STAYS SHOWING CONNECTION TO COPPER PLATE.
FIG. 44.

stays were completely wasted away, and this part of the fire-box side was in consequence dependent for support on the screwed parts of the stays in the stay holes, but owing to the repeated hammering and caulking of the ends to make them steam tight the threads had been seriously damaged and the stays had become too short, the ends being below the fire surface of the plate. In this condition they were unable to support the plate, and the latter was forced over the ends in the form of a bulge. Once the bulge started the surrounding part of the plate appears to have slipped easily and rapidly over the adjacent stays, many of which also were without proper heads, the scalding steam and water escaping through the stay holes into the fire-box and thence to the atmosphere. When the bulge had extended the full length of the side of the fire-box to the back plate and tube plate, these crumpled in and the bulged side appears to have begun to tear away at the two upper corners simultaneously, and after completely tearing along the top, it was driven downwards, hinging along a line level with the top edge of the upper row of rivets attaching the bottom part of the side to the foundation ring, and it appears to have held on at this part until the plate itself had bent through an angle exceeding 180 degrees from its original position. The plate was then blown to the left-hand side of the boiler, its flight in that direction being due to the bottom edge remaining attached to the foundation ring until the last. The failure of the side stays described above occurred with extreme rapidity, the whole operation lasting probably less than a second."

CHAPTER XIII

THE FIRE-BOX

WE have now to consider more in detail how the crown sheet or top of the fire-box is supported. In the older type of engines the outer shell is always semicircular. The metal is in tension, and no staying is required. Two methods of supporting the inside box have been mentioned. The first, and by far the most common, consists in bridging the top with girders, and slinging, so to speak, the crown sheet from these girders. Formerly the

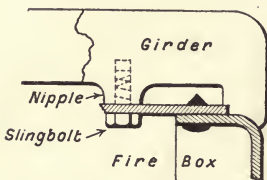

FIG. 45.—Girder stay.

girders were always made each of two wrought iron flitch plates, riveted together with distance pieces between. The sling bolts came up between them, and the nuts were carried on large washer plates spanning both bars. In the present day cast steel bars are used.

These have nipples on them which are bored and tapped, and into these the sling bolts are screwed as at N N, Fig. 39. The ends of these girders, no matter how they are made, are extended downwards and very carefully bedded on the fire-box in a way which will be best understood from the sketch, Fig. 45. In most cases—invariably in this country—the girders run fore and aft instead of transversely. Seeing that the shorter a beam is the stronger it is for a given section, this appears to be a mistake. The long girder has not been retained without a reason however. The internal fire-box is always built up of a single sheet of copper—which may be as much as 8 feet wide by 18 or 20 feet long—a front plate known as the tube sheet, and a third known as the back plate. The system is rendered necessary by the fact that the tube sheet is nearly twice as thick as any of

the other plates. The back plate and tube plate are flanged inwards all round, and the plate forming the sides and crown is riveted over these flanges in the way shown in Fig. 45. On the flanges rest the toes of the girders, which transmit their load down the vertical plates, which are stiffened by the stays and the tubes, so that they cannot buckle. Ultimately in this way the stress is transmitted to the foundation ring. If the girders ran across they would find no adequate bearing for their toes; but besides this, as holes fitted with screw plugs are provided in the upper part of the outside back plate, clearing rods can be passed between the girders to remove deposit from the crown of the fire-box in a way that would be impossible with the transverse girder. It is also thought that the circulation in the boiler is better with longitudinal girders. The strength of these girders is generally calculated by the formula for a beam of uniform section, supported at each end and carrying a distributed load.

Let w = the load in pounds,
 b = breadth of beam in inches,
 d = depth of beam in inches,
 l = length of beam in inches,
 c = a constant, usually 16,000,

Then
$$\frac{16,000 \times d^2 \times b}{l} = \text{safe load.}$$

Of course when the girder consists of two flitch plates, b will equal the sum of their thickness.

The reader will probably have noticed that many of the locomotives of the Great Western and Great Central Railways have boilers with large rectangular structures over the fire-box. The illustration Fig. 46 of one of Mr. Churchward's boilers (p. 104) shows this very clearly. The side plates of the outer fire-box, instead of forming a semicircle as just described, are carried up and united by a flat at the top, in so far representing in shape the inside fire-box. This design was the invention of Mons. Belpaire, a Belgian engineer, and it possesses several advantages. It gives a large steam space, and it entirely dispenses with the heavy bridge girders. The method of staying is the first referred to on p. 95. The crown of the inside fire-box

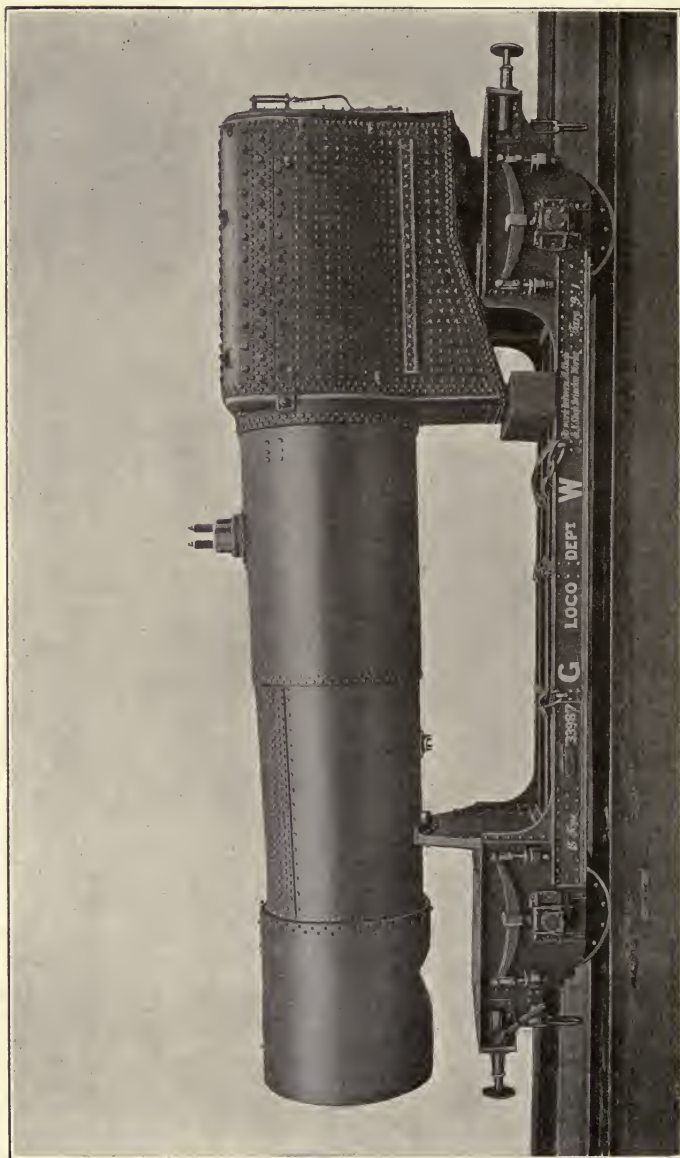

FIG. 46.—Belpaire boiler, "Star" class, Great Western Railway.

is supported by screwed stays just as the sides are, only the stays are much longer. The flat sides of the outer box are supported by transverse stay bolts. Some modifications in the size and arrangement of the stays have been introduced by different makers, but with these we need not concern ourselves.

Attention has been directed to the prejudicial action of expansion and contraction. It is the usual practice, as already stated, to tie the bridge stays each by two slings, P P (Fig. 39), to the semicircular crown of the fire-box. However tightly these may be screwed up when cold, as soon as the box is heated, by rising it leaves the slings slack, and they can then give no real support. The idea is, however, that they prevent the gradual crumpling down of the front and back plates under the toes of the girders, and that in any case they will help to prevent the blowing down of the crown plate should the side stays give way and permit the fire-box plates to buckle in. It does not appear, however, that there is any recorded instance of this. When a crown collapses the girders or the slings break. Unless care is taken in fitting the slings they may do much harm. It is right to state here, however, that many engineers hold that the rising of the inner box only takes place when steam is being got up, and that when the boiler is fully heated the slings to the roof are again tight. But the fact remains that the co-efficient of the expansion of copper being much greater than that of steel, the crown of the inner box must be higher up in the boiler when it is hot than when it is cold. To this it is replied that the outer crown rises a little by expansion while the roof girders spring or deflect downwards a little under the load, and so the slings come into use. Whatever force may be allowed to these arguments as mere expressions of well considered opinion, the fact seems to remain that girder sling stays prevent the gradual crushing down of the tube plate, which in process of time makes the holes oval and renders it almost impossible to keep the tubes tight. No doubt the parts under stress fight it out among themselves and adjust their differences. We may take as proved that the all but universal employment of these girder slings is not the result of fashion or prejudice; they are of use or they would not be fitted.

A very simple boiler has been made by slightly curving the top of the inside box and staying it directly to the curved top of the outer box, some of the stays, of course, radiating, as in Fig. 41. But the stays then prevent the inner box from rising when expanding, and a heavy stress is put on the foundation ring, tending to buckle the plates at the root of the fire-box. At first sight, the Belpaire arrangement would be open to the same objection, but it is not, because the plates are flat and pliable, and stresses are taken just as they should be taken. Two objections have been urged against the Belpaire design; one is that it is very ugly, which we may pass over; the other is more serious. It is, that the external fire-box interferes with the driver's view. On the continent the objection does not apply, because a footplate at least a foot wider than that which the loading gauge permits in this country is admissible.

The reader is referred to detailed descriptions of the locomotive for information about the various methods in use for supporting such plates as the back plate above the inside fire-box, and the smoke-box tube plate above the tubes. It is enough to say here that longitudinal steel bars running from end to end of the boiler in the steam space are often used.

Mention has been made of the foundation ring, sometimes called "the bottom rail," by which the space between the inside and outside fire-box is filled up at the bottom. It has already been shown in section, Fig. 39. It is in the present day almost invariably a rectangular steel casting softened by annealing. When it has been roughly fitted it is ground all over to remove scale and impart a true surface. It is put in place and holes are then drilled through it and the inside and outside boxes, and rivets subsequently put through these secure the boxes to each other; afterwards the seams are caulked on the outside. Foundation rings, if well made and fitted and properly riveted, give little trouble.

A firing hole is provided in both the inside and outside fire box. The space round this must be filled up. At one time, a ring precisely similar to the foundation ring, but much smaller, was used in the same way, see Fig. 39. For some

reason, not quite clear, the inner seam between the copper and the ring was very liable to leak. One improvement consisted in dishing the copper plate, so that only a thin ring was required. This checked leaking, but the copper was found liable to groove or crack in the dished part, and the method shown in the accompanying sketch, Fig. 47, invented by the late Mr. Webb, of the London and North Western Railway, finds much favour. The inside fire-box is bent outwards all round in the form of a truncated cone. The back plate of the outside box is dished in like manner to fit it. The inside fire-box without the foundation ring, can be dropped in as far forward as it will go, and is then pushed back until the inner cone slips into the outer one. A special tool for drilling the plates in place for the rivets is used.

Some diversity of opinion exists as to the quality of the copper in a fire-box. Many engineers specify for "pure" copper. This appears to be a mistake, for pure copper is very soft and will not withstand the attrition of the burning coals. The consequence is that the lower parts of the boxes are worn thin, and have to be renewed. It is a much safer practice to specify for "best" copper, which is by no means the purest. The specification in use on the London and South Western Railway is given here.

"The copper is to be of the very best quality manufactured, and to be of the exact dimensions, both as regards form and thickness, as given on the drawings or list supplied.

"The copper plates are to be properly annealed, and a piece taken from each plate must stand the following tests, viz. :—

"The ultimate tensile strain to be not less than fifteen tons per square inch, with an elongation of not less than 40 per cent. in 2 inches.

"A piece 6 inches long is also to be bent double when cold without showing signs of fracture at the heel of the bend.

"A duplicate test piece to be sent to Nine Elms to be tested.

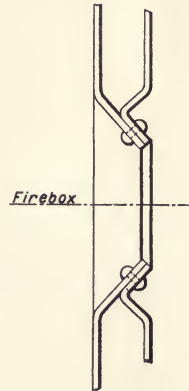

FIG. 47.

“ Any question arising must be referred to the Chief Mechanical Engineer, whose opinion and decision are to be taken as final and binding.”

The grate H, Fig. 39, which in this country is always made of thin wrought iron or steel bars, wedge shaped in cross section, is carried on bearers, resting on studs screwed into the copper box. A great many patents have been taken out for improvements in grates, and some of very ingenious construction are in use in other countries. They are usually of the “ rocking ” type, and are intended to break up slag, and keep the air spaces clear. They are not used in this country, because the coal is good and clean.

Great diversity of practice exists as regards fire doors. No two railways use the same kind of door. It has to be so small that the amount of air passed through the fire hole can be regulated, and it must be under the control of the driver with one hand, as he opens it for every shovelful of coal put in by the fireman, closing it again immediately. A long chapter might be written on fire doors alone, the quality of the coal and the method of firing mainly determining its construction.

In the early years locomotive furnaces had no ash pans. The dropping of red-hot cinders on the road was found to be objectionable, and a plain “scoop” of sheet iron was placed under the box. This caught the cinders; but it did more, its open mouth caught the air, which rushed up through the fire-bars and greatly promoted combustion, too much so indeed. Then a flap was fitted in front, controlled by a rod from the foot-plate, and the fireman found himself provided with a very efficient means of regulating the draught. When the engine was standing, by closing the damper he could save fuel and prevent waste of steam. But further experience showed that the ash pan might be made to play a more important part. The combustion of the fuel is effected partly by air admitted through the grate bars and partly by air admitted through the fire hole. The latter is regulated by the fire door, the former by the ash pan damper. Long since the ash pan became a somewhat elaborate contrivance. In the United States the dampers are sometimes worked

by steam cylinders. The following description of the ash pans designed for use on the London, Brighton and South Coast Railway is taken from a paper which was read before the Institution of Civil Engineers by Mr. Stroudley. Speaking of the Gladstone class of express engines with four coupled drivers and a pair of trailing carrying wheels under the foot-plate, he said: "Care has been taken to provide these engines with means for effecting perfect combustion of the fuel, and to prevent the emission of sparks. To do this, they have been fitted with an air-tight ash-pan, which has an angle across the opening for the damper at the back. Water is allowed to escape into this to quench the ashes, and so keep the firebars cool and in good order. A deflector-plate is placed across, above the opening for the damper, pointing inwards, and this throws the cinders which fall near the opening towards the centre of the ash-pan. The opening itself is covered to within $4\frac{1}{2}$ inches of the top, with a perforated plate mounted on hinges; this allows the air to pass into the ash-pan, and prevents large cinders from falling out. A damper, having a handle convenient to the driver, is arranged to shut practically air-tight, giving him the means of adjusting the amount of air. These contrivances, combined with the comparatively extensive grate and heating-surface, and with large blast nozzle, entirely prevent the emission of sparks. The ashes carried forward into the smoke-box would pass through a sieve having $\frac{1}{8}$ -inch mesh; the average quantity being, for the heavy passenger or goods engines, about $2\frac{1}{4}$ cubic feet per 100 miles run."

All the air for the grate is admitted at the back, not the front, of the ash pan.

The flue tubes, B B, Fig. 39, which run through the boiler barrel, are usually 2 inches in diameter and 8 to 11 feet long in this country. In the enormous boilers which have come into vogue in the United States they are 14 to 20 feet long and as much as 3 inches in diameter.

In British practice, they are usually spaced $\frac{3}{4}$ of an inch apart. In some boilers, tubes have been used only $1\frac{1}{2}$ inches in diameter inside, spaced but $\frac{5}{8}$ inches apart. This is bad practice,

because evaporative efficiency depends, as will be shown when the actual working of a boiler is dealt with, on much besides heating surface. The late Mr. W. Adams, many years ago, when locomotive superintendent of the North London Railway, startled the world by introducing 1-inch water spaces—a wholly unorthodox innovation—with 2-inch tubes. Instead of losing in power his boilers steamed much better than before, and the tubes did not leak.

Flue tubes are made of copper, brass, mild steel, or mild steel with a length of about one foot of copper brazed on to them. The holes in the smoke-box tube plate are always bored from $\frac{1}{16}$ inch to $\frac{1}{8}$ inch larger than those in the fire-box tube plate. The leading end of the tube for a length of 2 or 3 inches is swelled out to fit the larger hole; the purpose of this is to facilitate the taking out of a tube, which always has a little scale on it. This will pass through the larger hole.

As an example of modern practice a Lancashire and Yorkshire Railway tube specification is given here:—

“Copper tubes must be solid drawn and seamless, perfectly sound and well finished; free from surface defects, and also capable of withstanding expanding and bending, without showing the least sign of splitting, or cold shortness. The ends must be left ‘hard,’ or ‘half hard,’ throughout, because, if the ends are annealed, the junction of the hard and soft metal becomes a plane of weakness, and the tube invariably collapses there. The thickness must be 10 I. W. G. = 0·133 inches, for 12 inches from the fire-box end, and then taper from 10–12 I. W. G. in a length of 18 inches. The remainder parallel 12 I. W. G. thick; to be swelled $\frac{1}{16}$ at the smoke-box end to facilitate withdrawal. The weight per lineal foot is as follows:—

“DIAMETER OUTSIDE.

1 $\frac{5}{8}$ in.	...	1·98 lbs.	
1 $\frac{3}{4}$ „	...	2·15 „	A maximum of 10 per cent.
1 $\frac{7}{8}$ „	...	2·31 „	above each, and 5 per cent.
2 „	..	2·47 „	under will be allowed.
2 $\frac{1}{8}$ „	...	2·63 „	

“They must be free from dirt inside and out, each tube must be branded, and capable of sustaining an internal pressure of 800 lbs. per square inch and an external pressure of 250 lbs. per square inch.”

As to the popularity of various materials, the author is indebted to the North British Locomotive Co., Hyde Park Works, Glasgow, for the following facts. Of the last 834 locomotives built by the Company, 566 had brass tubes, 61 had copper tubes, 89 had steel tubes, 118 had iron tubes. On the Great Western Railway mild steel tubes have been used exclusively for some years. In the United States steel or iron tubes are always used.

The quality of the tubes and the way in which they are fixed in the plates is of very great importance. The leakage of tubes is a matter of almost daily occurrence, and when it is at all considerable it is very mischievous.

For many years the tubes were always fixed in the same way. They were put in place, and then a smooth tapered “drift” was hammered into them. The metal was in this way expanded and the joint between the tube and the plate made good. To maintain tightness, a ring called a ferrule, about 2 inches long and one-eighth of an inch thick, made of wrought iron or steel, and slightly tapered, was then driven into the tube. The smoke-box end was not considered to need ferrules, because it was of iron, not copper. If a tube leaked afterwards the ferrule was driven in a little further. Sometimes the tube plate was cracked in this way; more often a tube was split. It was no uncommon thing to see an engine running with a dozen tubes plugged at each end with hard wood plugs, which were carried as part of the tool-box outfit. The “expander,” invented by Mr. Dudgeon, wrought a great improvement. The expander is a small circular frame in which are put a number of little hardened steel rolls. These can be forced apart by a tapered steel drift. The tool is provided with a heavy cross handle, by which it can be caused to revolve. It is placed in the end of the tube, the drift driven in by a tap with a light hammer, and the whole turned round by the cross handle. The little rollers then revolve inside the tube and literally roll out the metal, expanding the tube in a way

quite different from the action of the plain drift, and hardly ever splitting a tube. Tube-fitting in this way has become a very simple and straightforward job, requiring little skill, while drifting in the old way was a work demanding much practice and skill if the result was to be satisfactory.

If instead of plain rollers grooved rollers are used, then the tube ends can be swelled out on both sides of the plate. A beading tool on the same principle turns over the end of the tube and so prevents it from being pulled through the plate. Ferrules are still almost always used at the fire-box end, not to keep the tube tight, but to save the ends from destruction by the attrition of the minute hard cinders which are drawn through by the powerful draught.

Tube leakage is a disease from which the locomotive boiler is very likely to suffer. It is due to expansion and contraction. The tube expands, and if neither the fire-box nor the smoke-box plates will give way, the tubes slip in the holes. They are also liable to expand diametrically to such an extent that they dilate the holes in the copper tube plate beyond the elastic limit of the metal. The result is that when they cool they are slack enough in the holes to leak. Various methods of dealing with longitudinal expansion have been tried. One used by the late Mr. W. Stroudley on the London and Brighton Railway consists in cambering the tubes a little more than one diameter. Thus an 11 foot tube, 2 inches in diameter, would be uniformly curved by about $2\frac{1}{4}$ inches. When the tube expanded the camber increased for reasons sufficiently obvious. In other cases the smoke-box tube plate has had flexibility imparted to it by making it with a corrugated ring all round. The best and simplest plan, however, consists in making the front plate so large that a good margin exists all round between the tubes and the rivets by which it is attached to the shell.

The accompanying table may be taken as representing average practice of the best kind. Some makers turn out rather heavier, others rather lighter boilers with almost the same amount of heating surface. It must not be forgotten that pressures over 180 lbs. remain the exception and not the rule. Pressures of

200 lbs. and upwards entail difficulties in manufacture and maintenance. The boilers are heavier and require more staying, and they wear out sooner in the fire-box. Altogether it remains a disputed question whether an increase of pressure above 180 lbs. is justified commercially.

WEIGHT OF LOCOMOTIVE BOILERS.

The weights given are of complete boilers with fire-bars, but without any mountings.

WORKING PRESSURE 160 LBS. PER SQ. INCH.

Heating surface	976 sq. ft.	..	1,592 sq. ft.	..	1,956 sq. ft.
				tons cwt.		tons cwt.		tons cwt.
Weight of boiler and fire-bars	..			10 10	..	12 10	..	15 5

WORKING PRESSURE 170—180 LBS. PER SQ. INCH.

Heating surface	1077 sq. ft.	..	1,349 sq. ft.	..	1,931 sq. ft.
				tons cwt.		tons cwt.		tons cwt.
Weight of boiler and fire-bars	..			10 10	..	13 0	..	17 0

CHAPTER XIV

THE DESIGN OF BOILERS

THE smoke-box appears to be a very innocent addition to the boiler; not a thing about which much controversy can exist, yet it may be doubted if any other portion of the locomotive has been made the subject of keener disputes, or more varying practice. For a full explanation of the reason why, the reader must wait until a consideration of the locomotive at work comes up. For the moment it must suffice to point out that it is of extreme importance that sparks should not be ejected up the chimney which might set fire to crops at the roadside in dry weather; while on the construction of the box, and on what is inside it, depends in considerable measure the economy or the reverse of the boiler.

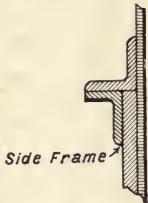

FIG. 48.

Usually the front tube plate and the front plate of all are rectangular below, and they rest on the cylinder castings when these are inside; or they are united by a flat horizontal plate. The bottom of the box is always filled in with fire bricks, set in fire clay, on which the hot cinders and ashes which come through the flue tubes are deposited. The boiler is invariably secured in the side frames at the smoke-box end. This is done in various ways, but it is always done. The fire-box is fitted with two angle steels riveted to it. The heads of the stay bolts in the wake of the side plates are countersunk to form a flush surface, or holes are drilled in the angle so as to fit over the stay bolt-heads, and the fire-box outer shell fits closely between the frames, to which are also riveted two angle steels on which those of the boiler rest, as shown in the sketch, Fig. 48. A few bolts passing



through oval holes and a slack fit are sometimes put through the angle irons, or a species of clip is put over both. As the boiler expands and contracts the angle steels on the fire-box slide backwards and forwards on those on the frames and straining is thus avoided.

To large numbers of boilers domes are fitted. These are short cylinders of steel, with tops bolted to them, sometimes made of cast iron, sometimes dished out of steel plates. The domes have large curved flanges at the bottom, by which they are riveted to the barrel. As a large hole is cut out in the barrel, a strengthening ring is fitted inside and the rivets pass through the three thicknesses of plate.

In some cases the dome is made large, and is regarded as an important factor in providing steam space. The steam, too, was always taken off by an internal steam pipe which opened higher up, above the general water level in the dome. The modern big engine boiler is so high that there is no room for a high dome, and that which is used plays rather the part of a convenient casing for the regulator valve than an addition to the steam space.

In the designs of boilers considerable differences exist. So long, however, as they are of moderate size, that is to say, with a heating surface of 1,200 to 1,400 square feet, and grates with 18 square feet or so of surface, they are all very much alike. The standard modern English locomotive is of the 4—4 type, that is to say, it has a four-wheeled bogie in front, and four coupled driving wheels; the cylinders are 18 or $18\frac{1}{2}$ inches diameter, the stroke 26 inches, and the working pressure 160 lbs. The driving wheels are 6 feet, or 6 feet 6 inches in diameter; the side coupling rods about 8 feet long. Between these there is no difficulty in getting in a fire-box 6 feet long. Mr. Drummond, chief mechanical engineer of the London and South Western Railway, has not hesitated to use side rods ten feet long, and they have been quite successful.

The shape of the internal box is modified by various considerations which have greater or less weight with different designers. The normal outer box for engines of the 4—4 type cannot have a

greater width at the bottom where the grate rests than 4 feet 1 inch, the gauge being 4 feet $8\frac{1}{2}$ inches. If from this we deduct the thickness of four plates, the inside and outside fire-box, two at each side—say, $2\frac{1}{2}$ inches, we have left, allowing a $3\frac{1}{2}$ inch water space at each side, 3 feet $2\frac{1}{2}$ inches for the width of the grate; with a $2\frac{1}{2}$ inch water space it may be 3 feet $3\frac{1}{2}$ inches wide. By reducing clearance, a little here and a little there, the absolute width of the box may be slightly increased so as to give a grate 3 feet 4 inches wide with a $2\frac{1}{2}$ inch water space. The idea is, of course, to get the largest grate area possible, but it will be shown further on that an increase or decrease of two or three inches in the width of a grate is of no importance, while an extra inch given to the water space may be of the utmost value. There is, indeed, excellent reason to believe that when pressures of 200 lbs. or over are used, the water spaces should in no case be less than 4 inches wide. It has been shown already that the longer the stay bolts are the better, because they are more flexible. But it is imperative that the circulation of water should be thoroughly efficient to prevent the plates from becoming over-heated. Copper, there is every reason to believe, deteriorates in quality when exposed for long periods to severe stresses when heated. The metal is always hotter than the water in the boiler; the temperature proper to 240 lbs., absolute—225 lbs. safety valve pressure—is 397° F. That of the inner face of the plate is perhaps twice this, and may be much more unless fairly “solid” water in rapid movement is in the water space.

So far the fire-box has been spoken of as though it was in all respects rectangular with the exception of the bending at the corners. This view is, however, incorrect, if we except very small locomotives. It has been pointed out that the width of the lower portion of the external fire-box cannot much exceed 4 feet, while that of the internal box can only be about 3 feet 3 inches. If now the inner box were carried up straight it would be impossible to get in a sufficient number of flue tubes; accordingly, the inner box is wider at the top than the bottom, and in this way a barrel even 5 feet in diameter can have all the tubes it will accommodate, say 300, put in.

But this is not all. The enormous engines now in use are fitted with grates as much as 9 feet long. These must be placed over the axle of the last pair of wheels and with this object the grate is made in two portions, one horizontal, next the fire door, and the other steeply inclined. The fire-boxes inside and out are cut to fit. This is very clearly seen in the photograph of a Great Western boiler on page 104. In certain cases the front portion only of the box is curved, the width required to accommodate the tubes being obtained by "pocketing out" the side sheets. The advantage is that more water space is left in the "legs" at each side. It is essential in some respects that when a boiler is large the fire-box should be deep. Now for reasons that will be explained, sunken or deep boxes do not make steam as freely as shallow boxes. To improve the deep box, Mr. Dugald Drummond, Chief Mechanical Engineer of the London and South Western Railway, some years ago put transverse water tubes into the fire-box, an experiment which answered so well that a large number of the most powerful express engines on the line have been fitted. A cross section of a fire-box is given on page 118, Fig. 49. The tubes A A are of very mild steel set on a slight incline, and are "rolled" into the inner box side plates just as though they were flue tubes. Access is got to them by doors at each side. These doors are carried on hinges for convenience, but the hinges have nothing to do in the way of securing them. The doors are made with faced joints, which are bolted to steel, faced, rectangular castings B B bolted in their turn to the outside of the fire-box shell. Through a certain number of tubes are passed stay bars C C so that the outer shell is properly braced. It can be proved that if a tube containing water is put on a slight incline, say one inch to the foot or even less, provided it is not more than twenty-four diameters long, it cannot be over-heated, the circulation within being very ample. The endurance of the Drummond tubes seems to be almost phenomenal. Their average life is eight years and two months and their average mileage is 306,992. After 200,000 miles they are clean inside and as good as new, and this although they are exposed to the highest temperature in the fire-box, which nearly approaches that of a

steel melting furnace. In the section it will be seen that bridge girders are not used. The crown of the fire-box is slung to the

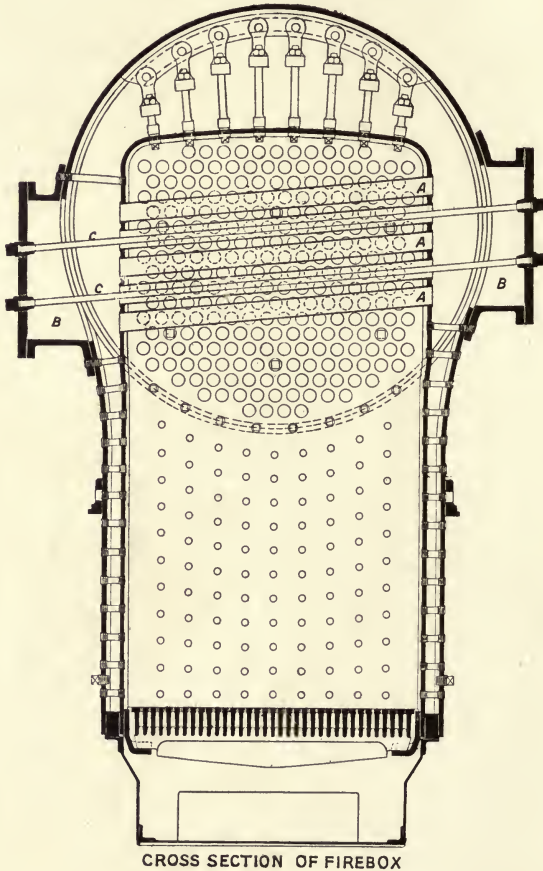

FIG. 49.—Drummond's water tube fire-box.

outer roof plate. But it will also be seen that the slings being in couples and fitted with nuts resting on cross pieces, the internal fire-box is quite free to rise when the fire is first lighted, simply lifting the nuts off the cross bars. With the advent of

pressure the nuts come down again to their bearings. In this way the principal objection to the sling stay is removed.

One other type of fire-box has to be described. In this country the best coal in the world is available for locomotives, and we have as yet built but a few boilers which can compete in dimensions with those of some freight engines in the United States. So long as the fire-box is placed between the frames, the maximum grate area cannot well exceed 28 square feet. This means a grate nearly 9 feet long, which is not easily fired. In Belgium much of the locomotive fuel is "dead slack." It is little more than coarse dust, and being moistened it is not much unlike black mud. This is burned by being spread out thinly on enormous grates—as much as 70 square feet in a few cases—50 square feet is quite common. Engines may be much wider in Belgium than in Great Britain, because Belgian platforms either do not exist at all or are very low. The fire-box does not go between the frames but rests on top of them. A width of as much as 9 feet being given to the external fire-box, grates 6 feet wide and 9 feet long become possible. There are two fire doors because the grate could not be kept covered from one. In this country a few locomotives of the "Atlantic" or 4—4—2 type have been built in which the external fire-boxes are about 6 feet wide. The grates stand over the trailing wheels, which are of comparatively small diameter. The details of construction do not demand any special description. They are in all respects similar to those already dealt with.

Incidentally, it may be mentioned that various attempts have been made to get rid of the flat-sided firebox. Thus circular corrugated furnaces similar to those in a marine boiler have been tried on various railways with but moderate success. It is very improbable that the normal box will be displaced by innovations.

It is assumed that the reader has now formed an adequate conception of not only what the locomotive engine boiler is, but why it is what it is. We have next to consider what it does, the nature of the work it performs, and how it does it. It is worth while, however, to repeat that there is no other type of steam

generator so suitable for being carried about the country at a high speed on a wheeled vehicle. Into none others could so much heating surface be put of just that kind best fitted to absorb the energy of a furnace working at a temperature not attained in any other boilers, save those of torpedo boats, and giving off huge volumes of intensely hot gas. It is not so much that the locomotive boiler is excellent, as because it is the only practicable boiler that it enjoys universal favour. It is in nowise too much to say that it is to the locomotive boiler we owe the success of the railway systems of the world.

CHAPTER XV

COMBUSTION

It is advisable here for the sake of completeness to put before the reader a few general facts concerning combustion. They ought to be known, although they are little considered in the everyday life of a railway.

The burning of coal means the chemical combination of oxygen, carbon and hydrogen, with the evolution of heat, carbonic oxide, and water in the form of steam. With the various other combinations of carbon, hydrogen, and oxygen, which take place we need not here concern ourselves. They have interest, of course, for the chemist, but not for the locomotive superintendent, the engine driver or fireman.

In most text-books it is taught that the whole of the energy comes from the coal, in which it has been stored up by the sun's rays acting on trees and plants millions of years ago, but no attempt is made to say how energy exists in the inert black substance. That remains one of the insoluble mysteries of nature. It may, however, not be out of place to advance here the theory that the energy does not reside in the coal, but in the gas with which it combines. Thus the molecular energy—that is to say, the energy due to the motion of its molecules—is much greater in oxygen than it is in carbonic acid gas. But this gas is the result of the combination of oxygen with the carbon. The difference appears as heat. If we turn to hydrogen, we find that probably of all known substances it possesses the highest molecular dynamic energy. Accordingly, when it combines with oxygen, water is formed which has little or no molecular energy, and the result is the liberation of the largest quantity of heat that can be obtained by direct combustion.

Leaving, however, the region of theory and turning to that of fact, the following figures, which show the heat of combustion with oxygen of one pound each of the substances named, in British thermal units are given, and also what is perhaps more to the point, in pounds of water evaporated from and at 212° F. The required weight of oxygen is also given. The figures are the result of a series of experiments carried out by MM. Favre and Silbermann some sixty years ago. Certain corrections have been made since, but they are unimportant refinements.

Combustible.	Pounds of Oxygen.	Pounds of Air.	Total B.T.U.	Evaporation.
Hydrogen gas	8	36	62,032	64.2 lbs.
Carbon imperfectly burned to CO... ..	1½	6	4,400	4.55 ,,
Carbon completely burned to CO ₂	2⅔	12	14,500	15 ,,

Rankine deduced from these figures the following formulæ for general application :—

Let C H and O be the fractions of one pound of the compound which consists respectively of carbon, hydrogen and oxygen, the remainder being nitrogen, ash, and other impurities. Let h be the total heat of combustion of one pound of the compound in B.T.U. Then

$$h = 14,500 \left\{ C + 4.28 \left(H - \frac{O}{8} \right) \right\} \quad (1)$$

Let E denote the theoretical evaporative power of one pound of the compound in pounds of water evaporated from and at 212° F. Then

$$E = \frac{h}{966} = 15 \left\{ C + 4.28 \left(H - \frac{O}{8} \right) \right\} \quad (2)$$

The facts of interest, as concerned with locomotive performance, are mainly that combustion should be so carried on that no CO shall be made. This end can be attained in theory with ordinary coal by admitting a minimum of 12 lbs. of air per

pound of coal. In practice, however, no complete union of all the oxygen can be obtained; and the minimum quantity of air requisite is about 18 lbs. per pound of coal. At 62° this would occupy a volume of about 235 cubic feet; then if a locomotive is running at 60 miles an hour and burning 30 lbs. of coal per mile, the volume of air admitted to the fuel will not be less than, in round numbers, 7,000 cubic feet. But at $2,000^{\circ}$ F. a pound of air occupies 62 cubic feet, instead of 13 cubic feet, and so the volume which has to be withdrawn from the fire-box through the tubes is not less than 33,480 cubic feet per mile and per minute. Inasmuch, however, as the gas is rapidly cooled in its passage through the tubes, it contracts in them, and thus, although 33,480 cubic feet enter at the fire-box end of the tubes, probably not more than 16,000 or 17,000 are delivered into the smoke-box.

It must be carefully borne in mind that these figures are simply approximations. They are based on the weight of air used and do not include the volume of CO, for example, which replaces an equivalent volume of air. They are given here only in order that some idea may be formed of the quantities which must be dealt with in the ordinary working of a locomotive engine. Thus we see that while some 33,000 cubic feet have to get into the tubes, only about 17,000 have to get up the chimney. In order that this end may be attained means must be provided for exhausting the smoke-box, so that the external pressure of the atmosphere under the grate bars and at the fire door may be greater than that at the top of the chimney. This result is secured by turning the exhaust steam from the cylinders up the chimney. It was the employment of the exhaust in this way that enabled the "Rocket" to beat all its competitors at the Rain-hill trials; and a very keen discussion at one time took place as to who invented a device which has proved of crucial importance to the railway system. Indeed, it is in no way second in value to the tubular boiler, which without the blast pipe would be useless. It is true that forced draught by means of a fan might have been adopted; but it could not compare in general efficiency and activity with the blast pipe. What the blast pipe

is, and how it works, will be considered when we come to the smoke-box. The two original claimants for its invention were Davie Giddies, a friend of Trevithick, and George Stephenson. The honour of inventing it is also claimed for Trevithick himself. In the "Life of Richard Trevithick," written by his grandson, Francis Trevithick, published in 1872 by Messrs. Spon, will be found, on p. 154 of Vol. I., a letter which refers to a locomotive for common roads, which was built to Trevithick's designs in 1802. A passage in this letter has been construed to mean that the exhaust steam was used to produce a draught; but as it stands the passage is quite unintelligible. On p. 125, however, of this volume is a description of the famous Camborne engine, the first locomotive that ever conveyed passengers, and we are told that "The exhausted steam having done its work in the cylinder at a pressure of 60 lbs. to the inch, passed into the chimney as a steam blast causing an intensely hot fire, and in its passage it heated the feed water."

There is reason to believe, however, that it was in no sense any one's invention. The obvious way to get rid of the exhaust is to turn it up the chimney. Thus, leaving Trevithick out, it is known that this had already been done in Hackworth's engine of the "Puffing Billy" type. Its action in promoting combustion in the "Rocket" seems to have been a discovery rather than the result of a direct act of invention. It is of interest to add that it is fairly certain that the knowledge that a steam jet would entrain air and so induce a draught was possessed by the old Greeks and Egyptians. More to the point, however, is the fact that in 1594 Sir Hugh Platt published an enquiry and a description of "a round ball of copper or of latten (brass) that blowes the fyre verie stronglie by the attenuation of water into ayre." The ball or balls were to be "hung in the chimney directly over the fyre to cure smoky chimneys, for being so hung the blast arising from them carries the loitering smoke along with it."

For many years after railways began to play an important part in the world's work locomotives were fired with coke. Most of the railway companies manufactured their own coke. Fifty

years ago coke ovens still existed near New Cross, the property of the South Eastern Railway Company. It was just the fuel for the locomotive boiler. The tubes kept clean, there was no smoke and no soot. It was believed that flame could not pass through a tube only $1\frac{1}{2}$ inches or 2 inches in diameter, and coke made little flame. Engines on the best lines were spotlessly clean. Drivers and firemen wore white clothes in summer. When the steam was shut off the supply of air diminished and much carbonic oxide was evolved. This escaping up the chimney at a high temperature caught fire the moment it reached the outer air. At night engines arriving at say, Rugby, came in with a long trail of lambent blue flame from their funnels. The sight was pretty, but not comforting to those whose luggage was stowed, as was then the custom, on the roofs of the carriages.

Coke was an expensive fuel, and about the year 1860 a determined effort was made to substitute coal for it. Patents were taken out by the dozen, and large sums of money were expended by the railway companies with very indifferent success. They could not burn bituminous coal without sending torrents of smoke into the air, and the engines did not make steam. The trouble was, however, at last got over by very simple means. Across the fire-box was thrown a fire brick arch supported at the ends on studs screwed into the copper plates, as shown at F in Fig. 39. The forward face of this arch came below the ends of the tubes. The rear side was pitched rather above the level of the top of the fire door. Into the fire hole was fitted a sheet iron scoop deflector, G, Fig. 39. When the train was running, the fire door was left partly open, and the ash-pan dampers were more or less closed. The products of combustion could no longer rush straight into the tubes. They had to curl backward to get to the upper side of the bridge. Now the bridge very quickly became white hot, and kept up the temperature of the gases; but these encountered a rush of air, which the scoop beat down on them and the surface of the blazing coal below. The result was that the space above the brick arch became full of a brilliant white flame, and no smoke worth mentioning came out of the chimney.

With various modifications, principally in the construction of the fire door and of the bridge, as for example the use of toggled instead of plain wedge-shaped bricks, this is the system invariably adopted on all railways everywhere to-day where coal is burned with a minimum of smoke. The arrangement is represented diagrammatically in Fig. 39.

CHAPTER XVI

FUEL

It would be mere waste of space to reproduce here any of the elaborate tables which have been prepared from time to time setting forth the constituents of coal. The railway companies purchasing coal by the 100,000 tons at a time do not much concern themselves with analysis unless coal from a new seam should be brought to their notice. The locomotive superintendents purchase particular coals or leave them alone as the result of experience; and the selection is based on quite other considerations than a chemical analysis, which might be quite misleading. Nevertheless, on all the great railways coal testing is continually carried on in the laboratories as a check on the results of practice, and to make it as certain as the analytical chemist can that the companies get full value for their money. Various characteristics of the coal have to be kept in mind, and as a good deal of misconception appears to exist, it is worth while here to state the facts as they are.

Coal is only a means to an end. That end is the production of steam. The price paid by the railway company for its steam depends largely, but of course not altogether, on the performance of the coal. Let us suppose that a given coal costs ten shillings a ton, and that it is so good that each ton of it will make ten tons of steam.

A different coal is to be had, however, which will make only eight tons of steam per ton. This coal it will be said is inferior to the first. So it is in one sense, but it may be selected notwithstanding by the railway company because it costs only seven shillings a ton. With the expensive coal seven shillings will only supply seven tons of steam. The second-rate coal will give

eight tons for the same money. Here then we have one factor in the work of selecting coal.

But not only has the cost of steam to be considered, but the rate at which it is made. Thus a coal in other ways desirable on the score of price, might be quite unfit for express work, when the power of the engine is taxed to the utmost and steam must be made as quickly as possible. The cheaper coal might, however, answer very well for goods and slow passenger trains. The dear coal might be a necessity for one class of traffic, and cheap coal quite suitable to another.

In the present day, moreover, there is a factor so important that it in a way overshadows all others. The coal burned on long continuous runs, such as are now fairly common on most lines, must be free from any impurity which will cause clinkering. Lime is a great offender in this respect. Again, a trace of iron will cause the formation of "birds' nests"—rings of clinkers like india rubber umbrella rings—round the ends of the tubes in the fire-box, which obstruct the draught. At sea and on land, fires can always be cleaned, but no cleaning can take place with a running locomotive. If clinkers form on the fire bars they may indeed be broken up, but the steaming power of the boiler will be seriously affected. Time cannot be kept with a "dirty fire." The coal used on these long runs is known by experience to be good. Nothing that can be done in the laboratory can give the same certainty of the attainment of a desirable result.

Another quality essential to a good locomotive coal is its keeping power. Large quantities are of necessity stored by the railway companies. The coal parts continuously with its more volatile constituents. No coal a year old is as good as coal fresh from the mine. Some of the Welsh steam coals, in other respects the best coal in the world, deteriorate rapidly by "weathering." Some of the bituminous coals will keep for years with little loss. It is practically impossible to gather from chemical analysis whether a coal will keep well or not; experience is the only certain guide. Yet another factor is the mechanical structure of the coal. Thus, some coals, otherwise excellent, are exceedingly friable. They fall into dust the moment they enter

the furnace, and go through the bars or up the chimney. They are besides bad to handle, being brittle and producing a large quantity of slack and dust when put in or taken out of wagons or tenders. Others again swell up in the fire, and check the passage of air.

It will be seen that while the selection of a coal is simplified so long as it is obtained from certain seams whose quality is well known and whose reputation is kept up, it is by no means easy when new supplies are offered in the half-yearly competition for railway coal contracts.

We now come into a region of pure empiricism, namely, the process of burning the coal whatever may be its quality. We have seen how much air is needed, in theory—what the actual quantity used is no one knows, because it cannot be measured. The firing of a locomotive is skilled work. To get the best results is an art not to be acquired in a few months, and never acquired at all by some men; and the reason is that there are factors in operation which are quite inexplicable on any known theory, and which can only be utilised or combated by men who thoroughly comprehend what they are doing.

It is to be understood that we are speaking now of express locomotives hauling heavy passenger trains at high speeds. As a rule, the boilers of these engines are worked very nearly to their utmost capacity. It is, therefore, inevitable that the fire shall be kept in the best possible condition for steam-making. What is that condition? It is not unlikely that it is different for every engine. But leaving this on one side, only a general answer can be given. It is a matter of common knowledge with all those who have to do with the generation of high temperatures by the direct firing of coal, that it is possible to attain certain conditions which result in maximum efficiency; and that these conditions can be quite easily upset by trifling changes apparently quite inadequate to the results they bring about.

Applying this to a locomotive, we find that everything is going well; she is keeping time; the pressure gauge is steady, and the water at the proper level; suddenly the steam begins to fall. To all intents and purposes, the fire is apparently as it was. The

mischievous may have been wrought by putting a couple of shovelfuls of coal too far forward under the bridge. Why this should be so harmful no one knows. The mere levelling of the surface of the fire may have an important effect. One day an engine will steam well, another day all the efforts of the most skilful fireman "will not get her out of the sulks." The locomotive sets science at defiance. Just as the best powers of a horse or a yacht are only put forth in obedience to the will of someone who knows just what to do and how to do it, so does the locomotive depend for its efficiency on the driver and fireman—a fact either not known at all to the general public, or but faintly appreciated.

Inasmuch as the hauling power and speed of a locomotive engine depend on the quantity of steam that can be made in a given time, a primary consideration is the rate at which coal can be burned. If, for example, one engine can burn 30 lbs. a minute, and another engine 60 lbs. it is clear that, other things being equal, the latter engine is twice as powerful as the former. Now the quantity that can be burned in a given time depends on the amount of air that can be supplied to the furnace. So far no one knows how quickly coal will combine with oxygen. When the coal is in the condition of dust it will burn so fast that it explodes. Awful catastrophes have taken place in coal mines because of the chance ignition of the dust which filled the air in the workings.¹ The weight of air which enters the fire-box depends on the resistance to its entrance and the force available to overcome that resistance. This force is supplied by the establishment of a partial vacuum in the smoke-box. Other things being equal, the larger the grate the less the resistance to the passage of air. The products of combustion have to get into the tubes and rush through them. The combined area of opening through the tubes at the fire-box end is called the "calorimeter" of the boiler. It must not be confounded with an instrument, also called a calorimeter, by which the wetness of steam is measured and about which more will be said presently. Let us suppose that a given boiler has 200 flue tubes, each 2 inches in diameter inside. The cross sectional area of each is 3.14 inches and $3.14 \times 200 = 628$

¹ Dusty mines are carefully watered in the present day as a safeguard.

square inches. This is much less than the area through the grate bars ; very much less than the area of fire hole combined with that of the grate opening. It would be wrong, however, to suppose that it is too small. So far is this from being the case that it is only with the greatest difficulty that an equal distribution of the products of combustion among the tubes can be secured. They invariably follow the line of least resistance. It may be taken that in general they will select the highest tubes and will avoid those at the sides, but as will be shown presently, there are exceptions.

Draught is measured in inches of water. The horizontal prolongation of one leg of a U-shaped glass tube passes through the side of the smoke-box. When the engine is running, the exhaust establishes, as we have seen, a partial vacuum in the smoke-box. The water falls in one leg of the vacuum gauge and rises in the other. The difference in level is measured in inches and fractions of an inch. Under ordinary working conditions it varies between about one inch and seven inches. In 1893, Mr. J. A. Aspinall read a paper before the Institution of Mechanical Engineers recording draught experiments which he had carried out. These go to show, as was to be expected, that the air pressures vary all through the locomotive boiler. From 5 up to as much as 18 inches of vacuum have been measured in the chimney ; 3 to 7 inches in the smoke-box ; and 1 to 3 inches just over the brick arch. With a vacuum of 3 inches in the smoke-box, 60 lbs. of coal per square foot of grate per hour were burned. There seems to be reason to suppose that the rate of combustion varies directly in any given engine as the square root of the air gauge height. Mr. Paul holds that applying this rule to Mr. Aspinall's results, a vacuum of 3 inches in the fire-box would enable $60 \times \sqrt{3} = 105$ lbs. per square foot per hour to be burned.

The weight of the coal burned is always expressed in terms of square feet of total grate area and hours. Thus, let us suppose that an engine with 17 square feet of grate is running at 30 miles an hour, and burning 30 lbs. of coal per mile. As a mile is traversed in two minutes, the consumption is 15 lbs. per minute

and 900 lbs. per hour. Then $\frac{900}{17} = 53$ lbs. nearly. The consumption is 53 lbs. per square foot of grate per hour.

Nominally coal can be burned at nearly three times this rate by the aid of fans; but a considerable quantity then goes out of the chimney in the shape of cinders and large sparks. If we look into a locomotive boiler furnace through blue glass to save our eyes from the blinding glare, it will be seen that the surface of the fire is covered with dancing incandescent fountains of fine coal carried up by the force of the inrush of air through the fire-bars. If the draught is strong enough cinders may be seen snatched up and thrown over the bridge to enter the tubes. One hundred pounds of coal appears to be the maximum that can be burned without much waste per square foot per hour. These high rates of combustion are accompanied by extremely high temperatures. It is quite possible that as much as $3,000^{\circ}$ F. may be reached in the heart of the fire with good coal, and $2,500^{\circ}$ F. anywhere in the fire-box. When cast-iron fire bars were used, it was not at all an uncommon event to melt half a dozen down, and bring a run to an abrupt conclusion. The risk is diminished in the present day by using wrought iron or steel fire-bars, which are very infusible. Excellent fire bricks are required for the arch, which is severely tried, not only by the extreme heat but by the jolting of the engine. One way of expressing the power of a boiler is in terms of pounds of water evaporated per hour per square foot of grate surface; thus, if the 53 lbs. of coal spoken of above made 370 lbs. of steam, then it would be said that the boiler was capable of evaporating 370 lbs. of water per hour per square foot of grate.

The next factor is the heating surface, that is to say, all the inside of the fire-box and of the tubes. If there are 60 square feet of heating surface to one of grate, then the evaporation would be $\frac{370}{60} = 6.16$ lbs. of water per square foot of heating surface. These figures are given simply for the sake of illustration. What the real figures may be will be set forth presently.

As the hot products of combustion pass through the tubes

they are cooled down. Entering the tubes at, say, 2,000° F. they leave them at, say, 700° F. The greater the difference in temperature between the gas and the water in the boiler the more rapid will be the loss of heat by the gas. It follows, therefore, that the heating surface of the tubes is more effective near the fire-box than it is near the smoke-box. It has been said, with a fair approximation to the truth, that one-half of all the steam made in a locomotive boiler is produced by the fire-box and the first three inches of the tubes.

To ascertain facts, the engineers of the Chemin de fer du Nord carried out a series of experiments which have long been regarded as classical. These experiments have been recorded by MM. M. C. Couche and Paul Havrez in 1875 and 1876. The boiler of a small locomotive was divided by thin plate iron partitions into four sections. The first plate next the fire-box was only $3\frac{1}{2}$ inches from the tube plates. The fire-box was 3 feet square, with 9 square feet of grate and a heating surface of 60.28 square feet; the tubes were 125 in number, 12 feet 4 inches long, and about $1\frac{7}{8}$ inches diameter. The boiler barrel was divided into four sections, each 3 feet and a fraction long. Each section could be tried separately under steam of the ordinary working pressure. The draught was got by steam from another boiler. The conditions of the trial could be varied by plugging the tubes. The total heating surface with the tubes all open was 792.43 square feet; with one-half plugged, 424 square feet.

The result of this series of trials showed that from two-fifths to one-half of the whole quantity of water was evaporated in the fire-box section, which was about one-tenth of the whole surface. The table on page 134 gives some of the principal results, the fuel being (1) coke and (2) briquettes.

These figures are very instructive. They show that the efficiency of the tubes depends very much on the weight of hot gas passing through them, and on the nature of the fuel burned. It will be seen that in all cases the briquettes gave the best results; and this particularly when the consumption was least. The explanation of this is worth stating, because the fact is not without its influence on locomotive boiler design.

It has been incidentally mentioned above that at one time it was believed that flame would not pass through a small tube. In treatises on smoke prevention one still finds an analogy established between the safety lamp and a locomotive boiler. The safety lamp may become filled with gas flame, the gas—fire damp—passing through the gauze ; but the flame will not explode the mixture in the mine because flame cannot pass through

Weight of fuel burned per foot of grate per hour.	Quantity of water evaporated per hour per 60 degrees to steam at 60 lbs. pressure.				
	1st section.	2nd section.	3rd section.	4th section.	5th section.
COKE :					
	lbs.	lbs.	lbs.	lbs.	lbs.
48·5 lbs.	20	5·6	2·9	1·28	·72
85·7 ,,	23·6	10·6	5·8	3·44	2·47
BRIQUETTES :					
53 lbs.	23·5	5·4	2·5	1·33	·83
109 ,,	38·9	14	6·8	4·32	2·81
BRIQUETTES :	WITH HALF THE TUBES PLUGGED.				
	lbs.	lbs.	lbs.	lbs.	lbs.
43 lbs.	26·5	9	4	2·1	1·31
94·3 ,,	44·7	21	10·6	6·34	4·76

small orifices and so cannot get out of the lamp. This is, however, only one of those half-truths whose propagation has done so much harm in the world. It is only true of the lamp if it is shielded from a strong current of air ; otherwise the flame will be forced through the gauze with perfectly appalling results. Whether flame will or will not pass through the flue tubes of a locomotive depends in like manner altogether on the draught and on the diameter of the tubes. A moderate vacuum in the smoke-box will pull flame for as much as 6 feet through a 2½-inch tube.

In a locomotive worked to its maximum power there is little doubt that flame may extend a long way even in a 2-inch tube. If it did not then it would be mere waste of material to use, as is done abroad, tubes as much as 14 to 20 feet long with bituminous coal. The tubes in M. Couche's boiler were 12 feet 4 inches long. It will be seen that the last 3 feet or so added so little to the total result that it might have been suppressed, at all events with coke as a fuel, with apparently small loss. The reduced cost of the boiler and its diminished weight would probably have gone far in the way of compensation. It will be noticed that the briquettes were under all conditions better than the coke. Now there were no special smoke prevention appliances, and briquettes usually make much smoke. The probability is that the tubes were filled for a portion of their length with red-hot flame. The flame from a coke fire (if any) is blue, and of the Bunsen burner character. But the Bunsen flame gives out little or no radiant heat. The late Sir William Anderson years ago called attention to the circumstance that smoke prevention appliances to steam boilers, while often successful in one way, failed in another. A dull smoky flame filling flues radiates heat with great power, which clear flame does not; and the result was that while the economy of a boiler might perhaps be increased, its steam-making power was diminished. In the United States, tubes as much as 3 inches in diameter and of great length are used in the mammoth engines of which so much is heard. It is fairly certain that only the presence of flame in them renders the great length of them economical.

CHAPTER XVII

THE FRONT END

WE have now to consider the results obtained in everyday practice, and this cannot better be done than by reference to direct experiment.

Perhaps the most complete experiments of the kind ever carried out were those made by Professor Goss, of Purdue University, U.S.A., with an engine known as "Schenectady No. 1," a second engine known as "Schenectady No. 2," and at the St. Louis Exhibition.

With "Schenectady No. 1"—a fairly typical American locomotive—as much as 181 lbs. of Indiana block coal were burned per square foot of grate surface per hour; 1,037 lbs. of water were evaporated per square foot of grate, and 14.93 lbs. per square foot of heating surface per hour, representing 518 i.h.p. Taking a normal rate of combustion, namely, 64 lbs. per foot of grate, the evaporation was 507 lbs. and 7.20 lbs. The latter is the more important figure, because the power of a locomotive is very usually estimated by its heating surface. A normal English locomotive with 1,500 square feet of heating surface may be counted upon to convert $7 \times 1,500 = 10,500$ lbs., or 1,050 gallons of water into steam per hour. If the engine uses 30 lbs. of steam per effective horse-power per hour, that is to say, at the rails, then we have 350 h.p. available for haulage, including, of course, the engine and tender. This is, however, far from representing the maximum effort of which such an engine would be capable. The coal used by Professor Goss was soft and of indifferent quality. Judged by the conditions laid down above, the best result obtained was only 7.67 lbs. of steam per pound of coal, and that was in only one experiment. The

average was under 6 lbs. With English or Welsh coal, 8 lbs. might be reckoned upon, which could give one-third more steam, other things remaining equal, and about 465 horse-power.

At the Louisiana Exhibition, the De Glehn compound engine, very similar to "La France," put to work on the Great Western Railway, evaporated 8.83 lbs. of water per square foot of heating surface, the temperature of the feed being taken as 212° F., and the boiler was rated as 680 horse-power, and the total heating surface 2,656 square feet, if the inside of the tubes is taken, and 1,646 square feet if the outside. The difference is due to the fact that the boiler is fitted with Serve tubes, so called after the inventor, which have eight longitudinal ribs inside them.

We now come to the consideration of the leading end of the boiler—that section of it on which the chimney stands. It is an obvious cylindrical continuation of the barrel of the boiler, and is known as the smoke-box. Until recently it was short—just long enough to accommodate the flange by which the chimney is bolted to it; but of late what is known as "the extended smoke-box" has been introduced from the United States. It reaches out far in front of the chimney. The back plate of the smoke-box is, as has already been stated, the front tube plate. In the front of the smoke-box is a large circular door made with great care and accurately fitted, so that when closed and bolted no air may leak in. The bolts are moved by a central handle which in turn can be locked by a second handle on the same spindle. The door is required to give access to the tubes so that they may be swept or "run." The tool used is a long rod with an eye at the end through which some oakum or a strip of canvas is threaded. Ashes which collect in the smoke-box are removed from time to time through this door.

The smoke-box is included in what has come to be known as "the front end." It plays a part not less important than the fire-box in the daily life of the locomotive; and, as has already been stated, its construction and action have from an early period in railway history been made the subject of keen controversy and many inventions. The functions of the smoke-box cannot,

perhaps, be better described than in the following extract from Professor Goss's recent book on "Locomotive Performance," detailing the results of experiments carried out since September, 1891, at Purdue University, Lafayette, Indiana, U.S.A. "The term 'front end' refers to all that portion of a locomotive boiler which is beyond the front tube plate. It includes the extended shell of the boiler which forms the smoke-box, and in general all mechanism which is therein contained, such as steam and exhaust pipes, netting, diaphragm, and draught pipes. It also includes the stack [chimney]. The front end as thus defined is to be regarded as an apparatus for doing work, receiving energy from a source of power and delivering a portion thereof in the form of a specific result. The source of power is the exhaust steam from the cylinders, and the useful work accomplished is represented by the volumes of furnace gases which are delivered against the difference of pressure existing between the smoke-box and the atmosphere. That the power of the jet may be sufficient, it is necessary that the engines of the locomotive shall exhaust against back pressure. The presence of the back pressure tends to lower the cylinder performance, and it is for this reason that designers of front ends have sought to secure the required draught action in return for the least possible back pressure. In other words, the effort has been to increase the ratio of draught to back pressure, which ratio has been defined as the efficiency of the front end. The office of the front end is to draw atmospheric air into the ash pan, thence through the grate and fire; to draw the furnace gases through the tubes of the boiler; thence under the diaphragm and into the front end; and to force them out into the atmosphere. In order that this movement may take place a pressure less than that of the atmosphere is maintained in the smoke-box, so that when the locomotive is working there is a constant flow from the atmosphere along the course named and back to the atmosphere again. The difference in pressure between the atmosphere and the smoke-box is spoken of as the draught, and under normal conditions of running is represented by from 4 inches to 10 inches of water." As a result of a multitude of experiments

carried out with the locomotive "Schenectady No. 1," Professor Goss gives the following table:—

PERCENTAGE OF TOTAL DRAUGHT REQUIRED.

Miles per hour.	To draw air into fire-box.	To draw gases through tubes.	To draw gases under diaphragm.
20	22·6	41·1	36·3
30	30·1	33·6	36·3
40	30·4	32·0	37·6

All this is excellent as far as it goes, but it does not go far enough. It is not throughout of general application, and to practice in this country much does not apply at all.

The diaphragm is a baffle plate introduced to beat down the cinders and sparks and prevent their flight up the chimney. Diaphragms find no place in English locomotives. Again, as has already been explained, a large percentage of all the air required comes in through the open fire door, which offers little resistance. The major part of the work done by the exhaust in an English locomotive is expended in overcoming the friction of the tubes, and the netting or other devices used to prevent the ejection of sparks and cinders, and in the lifting and propulsion of the products of combustion up to the top of the chimney. The products of combustion and the air taken together will represent, say 20 lbs. per pound of coal burned. Let this be 40 lbs. per mile, and the speed a mile a minute, then we shall have 800 lbs. If the engine is indicating 500 horse-power, and using 25 lbs. of steam per horse-power per hour, we shall have 208 lbs. of steam to add, that is to say, about 1,000 lbs. of air and steam to be lifted per minute and blown out of the chimney top at a high velocity. Again, Professor Goss worked with an engine standing in a shed, and consequently took no account of the effect which may be produced by the rush of air through the front of the ash pan, which may easily amount to several inches of water. At sixty miles an hour, or 88 feet per second, the pressure of the air on a flat surface is about 17 lbs. per square

foot, or about 3 inches water pressure per square inch. This is the force of a full gale.

The designers of smoke-boxes in this country are trammelled by legal restrictions which either do not exist at all in the United States, or only in a lesser degree. It will not be far

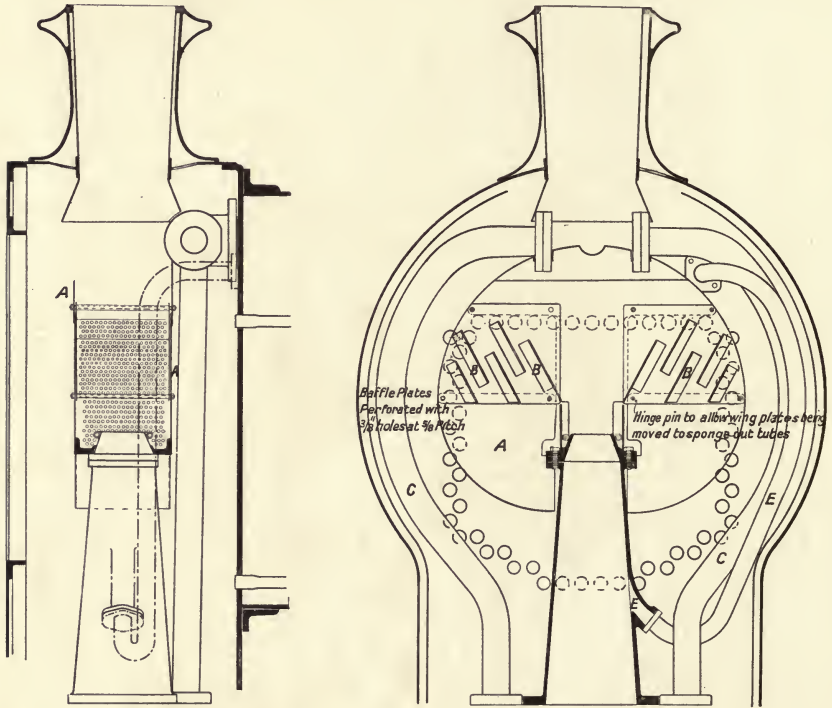

FIG. 50.—Smoke-box, London and South Western Railway.

from the truth to say that the first consideration with the designer here is that the locomotive shall not be likely to set fire to fields of standing corn, stacks, hay-ricks or woods past which it runs; the second is, that the production of black smoke may be avoided; the third, that the back pressure in the cylinders may be as small as possible, and the fourth, that the distribution of heat among the tubes shall be quite equal.

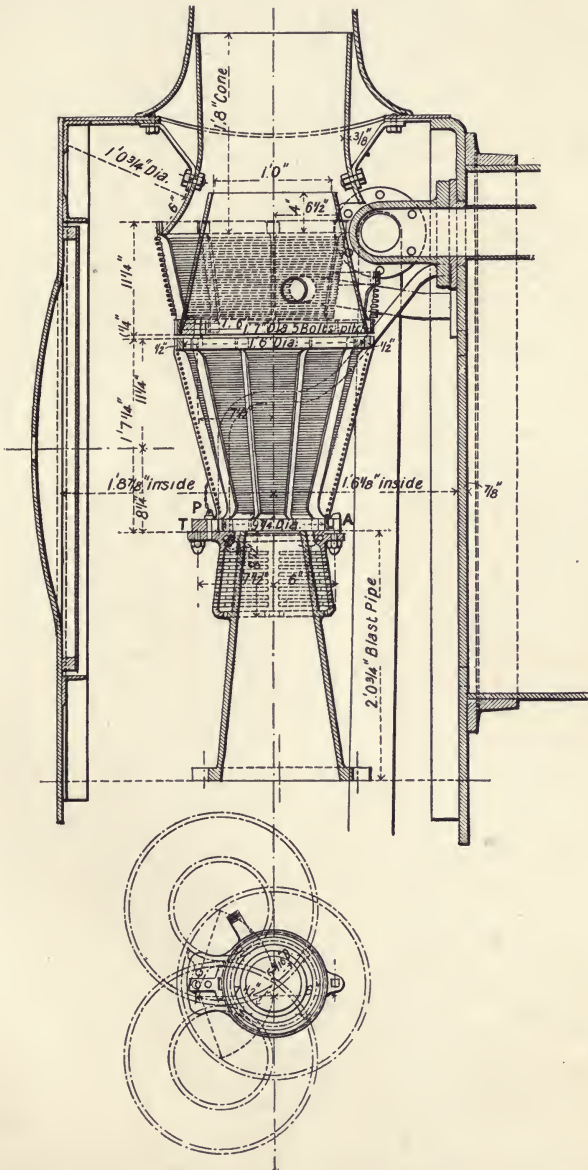

FIG. 51.—Smoke-box, South Eastern and Chatham Railway.

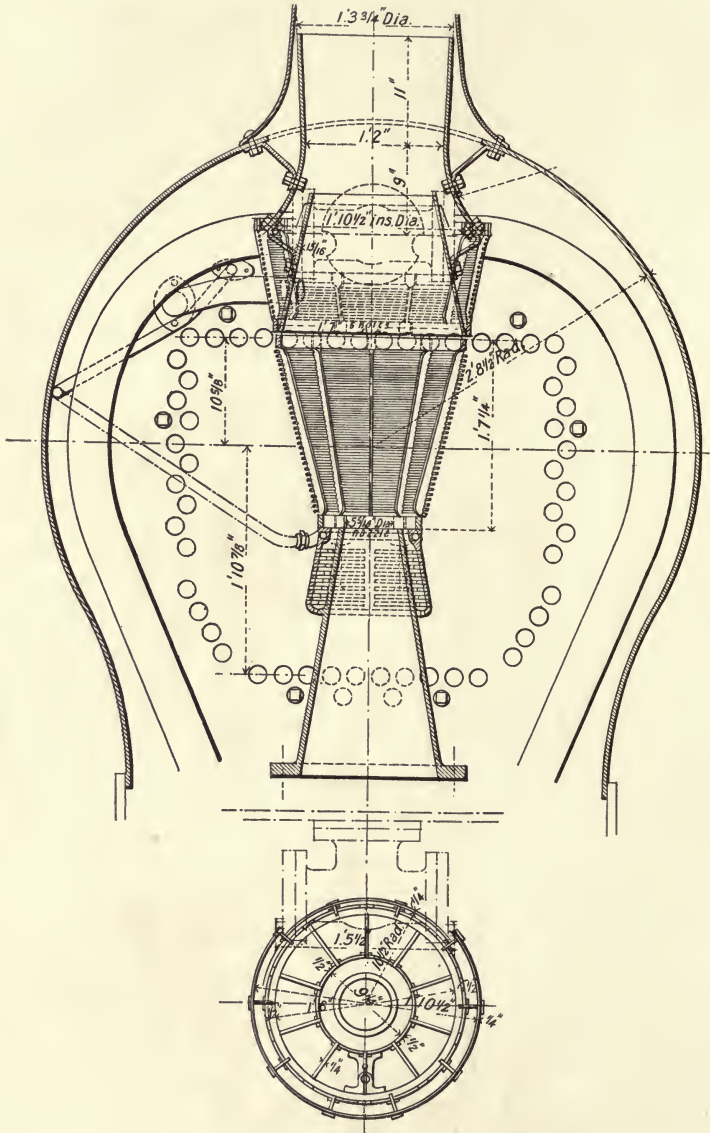

FIG. 52.—Smoke-box, South Eastern and Chatham Railway.

As to the first point, it has usually been found sufficient to place a flat grating in the smoke-box above the level of the tubes. Against the bars of the grating cinders strike, and are either broken so small that they can do no harm if they pass through, or else fall to the bottom of the box. A second device is the invention of Mr. D. Drummond, of the London and South Western Railway, which is illustrated on p. 140, and may be thus described, Fig. 50. In the smoke-box are placed two plates of thin steel A A. Between these plates are fixed others B B, closely perforated; C C are the two main steam pipes, E E is an ejection pipe for the vacuum brake. The hot gases fill the smoke-box, and only escape by passing through the perforations in B B from the sides of the smoke-box. Not only is this a most efficient spark arrester, but it is found that the effect of the blast on the fire is made more uniform, with a resulting economy not only in coal but in fire-boxes. Some are now running on the South Western Railway which have been in use for about nine years, in very heavy traffic. Figs. 51 and 52 illustrate Stone's spark arrester, which has been adopted by Mr. Harry Wainwright, Chief Mechanical Engineer of the South Eastern and Chatham Railway, for all his fast passenger engines. The conditions on these lines are very exacting because the coal used is at once dear and not very good, much of it running small and given to making sparks. The drawing requires little or no explanation. A double cone is fitted to the base of the chimney up the centre of which, carried on the ring T, the exhaust passes. The cone is made of a frame of ten bars, each $1\frac{1}{4}$ inch wide by $\frac{1}{4}$ inch thick. In the edges are notches, round the cone in these notches is wound a continuous steel wire $\frac{1}{4}$ inch thick. The notches are spaced wider and wider apart, counting from the bottom. Round the blast pipe is a brass ring as shown, in which slots are cut, these carry the suction action of the blast well down in the smoke-box. In order to give access to the tubes the whole lower cone may be turned round to the right or left on a pivot P by taking out a single pin A. This spark arrester works very well. Mr. Wainwright is perfectly satisfied with it after an experience extending over several years.

CHAPTER XVIII

THE BLAST PIPE

It has already been pointed out that the products of combustion will take the most direct course they can find to the outer air. They will follow the line of least resistance. The object of the designer is therefore to make all lines of resistance alike, and this seems to be very fairly done by the diaphragm plate. Indeed, Professor Goss tells us that a most elaborate set of experiments failed to detect any differences in vacuum in the space between it and the tube sheet. When the diaphragm is omitted, as in this country, there is good reason to believe that the central and topmost tubes pass more gas than the outer and lower tubes. It does not appear, however, that this seriously militates against the efficiency of a boiler.

The method of operation of the blast pipe has already been explained in general terms. A complete examination of the problem which it presents would be out of place in this book; but much that is at once interesting and ought to be known by those who wish to understand the locomotive remains to be said. The steam which has done its work in the cylinders is discharged up the chimney, in some cases through one pipe, in others through two pipes. In any case the pipes are two more in name than in reality. The blast pipe proper rests on a box which is a portion of the cylinders and to which it is bolted. It is usually somewhat oval in cross section at the bottom, and tapers slightly to the top where the "nozzle" is bolted on. This is always bored out truly cylindrical, and is made as large in diameter as possible, that is to say, between 4 inches and $5\frac{1}{2}$ inches. A greater diameter than 5 inches is exceptional. The larger the diameter the better, because the back pressure in

the cylinders, which is so much waste, depends for its amount more on the diameter of the blast nozzle than on any other factor. The smaller the nozzle, the greater is the velocity with which the exhaust steam issues, and the more powerful is its action in establishing a minus pressure in the smoke-box. Therefore, when an engine is found to steam badly, in the last resort a nozzle of less diameter than that in use is put on. This augments the back pressure and decreases the power of the engine; but the increase in the quantity of coal that can be burned in a given time more than compensates for this loss. So that an engine which will not keep time with a $4\frac{1}{2}$ inch blast nozzle may very well do so with a $4\frac{1}{4}$ nozzle. This is one of the many facts which show how sensitive a machine the locomotive is. There are, however, other factors besides diameter to be considered. It is essential that the nozzle shall stand absolutely under the centre of the chimney, so that a vertical line may be drawn through the centres of both. Care must also be taken that the blast is not projected against one side of the chimney more than the other. In some cases, particularly with outside cylinders, the blast from one cylinder hits one side, and from the other cylinder the other side of the chimney, although there is only a single nozzle. This means loss of efficiency, and to avoid it a partition usually extends some way up the vertical portion of the blast pipe. Again, the height of the nozzle in relation to the tubes is of much importance. If it is low it will usually be found that the lower tubes have the better draught. If it is high, then the upper tubes. Then the relation of the blast nozzle to the base of the chimney has to be considered. Sometimes raising the nozzle improves the draught, sometimes lowering it has that effect. Then the form of the pipe has an effect. Various blast pipes have been tried, such as Adams' Vortex pipe, a concentric pipe with the exhaust from one cylinder passing through the inner ring and the exhaust from the other cylinder through the outer ring and so on. It may be said that on the whole the advantage derived from these inventions has been too small to enable them to supersede the plain pipe to any extent. But advantage has been derived from supplements,

so to speak, to the blast pipe. Thus, in smoke-boxes of large diameter, "petticoat" pipes are sometimes fitted with advantage. These are intended to diffuse the "pull" of the exhaust and equalise the draught among the tubes.

In all cases a "blower" is fitted, which usually takes the form of a ring round the top of the exhaust pipe, which is perforated with a number of small holes. Through these, by opening a cock in the cab, steam can be blown up the chimney to create a draught when the engine is standing. The blower is used when getting up steam; in stations to prevent smoke; and is always turned on just before steam is shut off to prevent flames coming out through the fire door, by which the men on the footplate would be burned. Indeed, men have been killed in this way.

Until a recent period, the chimney was always a pipe of some length, as much, for example, as 5 feet, and it was wholly outside the smoke-box. But of late years huge engines have been built with boilers of great diameter, and the limits of height in tunnels and under bridges have reduced the apparent length of the chimney until it has been defined as "a frill round a hole in the top of the smoke-box"; in such cases the chimney extends down some distance into the smoke-box.

A curious fact is that on the continent of Europe no such uniformity of blast-pipe practice exists as in this country. There are, perhaps, fifty different kinds of pipe and arrangements of the smoke-box in use, and while it is claimed for each that it is the best possible, all seem to answer their purpose equally well. Thus, on the Austro-Hungarian State railways, the blast nozzle stands just inside the base of the chimney, a semi-circular grating just above the tubes acting as a spark arrester. On the Eastern Railway of France, the chimney is flared at the base, the blast pipe is level with the top of the smoke-box, and is rectangular instead of circular. The "nozzle" is fitted with two flaps or doors which can be brought together or separated by a rod from the footplate, so that the draught can be adjusted to the demand for steam. An express engine on the Paris, Lyons and Mediterranean line has been fitted with a nearly similar adjustable nozzle, while inside the chimney is placed a

long second tube up which the steam blower is turned. On the Belgian State railways rectangular chimneys are still in use. The list might readily be extended, if it were necessary, which it is not.

It is impossible to look at locomotives with understanding and not perceive that the chimneys vary remarkably in form and dimensions. The old rule was that the chimney should be the same diameter as the cylinder, and as long as possible. Thus, an engine with 16-inch cylinders had a chimney 16 inches in diameter. Not that there was any real connection between these proportions. The tendency in the present day is to keep down diameter. Thus, while an engine with 1,100 square feet of heating surface may have a 17-inch chimney, one with 2,200 feet will have a chimney no larger, possibly indeed smaller. It might indeed be argued from modern practice that no relation existed between boiler power and the dimensions of the chimney. There can, however, be no doubt that some forms and sizes of chimney are better than others, but apparently the difference is not great. Professor Goss carried out at Purdue University the most elaborate set of experiments intended to give data for standardising dimensions ever undertaken. The experiments were got up at the instance of the *American Engineer*, published in New York; and a very strong committee of representative railway engineers carried them out with the aid of Professor Goss on a locomotive known as "Schenectady No. 2," a more powerful engine than "Schenectady No. 1." It would be beyond the scope of this book to give more than the result of the inquiry as decided by the committee. This may be stated in six equations.

When the exhaust nozzle is on the centre line of the boiler

$$d = \cdot 246 + (\cdot 00123 H) D. \quad (1)$$

Here d is the diameter of the chimney in inches, H its height in inches, and D the diameter of the front end, that is to say the smoke box, in inches.

Tapered stacks were tried. It was assumed that they would act somewhat like a "diverging nozzle," and prove more efficient than straight tubes. The experiments enabled the important

conclusion to be drawn that a tapered stack of $13\frac{1}{2}$ inches diameter gives maximum results for all heights between the limits of $26\frac{1}{2}$ and $56\frac{1}{2}$ inches. The diameter of the tapered stack does not need to be varied with change in height. Hence, we may write for all locomotives and all heights of stack where the exhaust nozzle is on the centre line of the boiler

$$d = \cdot 25 D. \quad (2)$$

Here d is the least diameter of the tapered stack and D the diameter of the front end of the boiler.

It must be kept in mind that the foregoing equations only apply when the nozzle is on the centre line of the smoke-box. In this country it is almost invariably higher, that is, nearer the root of the chimney. Nor is practice in the United States, much less in Europe, invariable as to the position of the exhaust nozzle. Therefore, the committee carried out further experiments with varying heights of nozzle, from the results of which Professor Goss prepared the following general equations:—

For straight stacks:

When the exhaust nozzle is below the centre line of the boiler

$$d = (\cdot 246 + \cdot 00123 H) D + \cdot 19h. \quad (3)$$

When the exhaust nozzle is above the centre line of the boiler

$$d = (\cdot 246 + \cdot 00123 H) D - \cdot 19h. \quad (4)$$

For tapered stacks:

When the nozzle is below the centre of the boiler

$$d = \cdot 25 D + \cdot 16h. \quad (5)$$

When the nozzle is above the centre line of the boiler

$$d = \cdot 25 D - \cdot 16h. \quad (6)$$

Here d is for (3) (4) the diameter of the stack in inches. For (5) (6) it is the diameter of the "choke" or smaller part: H is the height in inches which should be the greatest possible; D is the diameter of the smoke-box in inches, and h the distance between the centre line of the boiler and the top of the exhaust pipe. These particulars by no means cover the whole ground traversed by the committee, but they are quite sufficient for the purpose of this volume. The inquiry appears to supply the

latest available information. As has already been pointed out, so much variation in practice occurs that it is doubtful that it has been altered to any considerable extent. As a result of the investigations, Professor Goss suggests a standard front end, the general arrangement of which and the chimney are given in Fig. 53. Here T is the front tube plate and K a diaphragm, the object of which is to beat down the cinders and sparks issuing from the ends of the tubes; W is the blast nozzle. The diaphragm finds no place in English locomotives. In America it appears in various forms, sometimes as a thin plate of iron, at others as a stout wire netting. It is invariably so made that it can easily be removed in order that the tubes may be swept. It may be taken as proved that the diaphragm checks the draught about as much as the fuel on the grate, but it appears to be a very efficient spark arrester.

Professor Goss gives the following rules as applicable to the standard front end:—

- Make H and h as great as possible.
- „ $d = \cdot 21 D + \cdot 16h$.
- „ $b = 2 d 02 \cdot 5 D$.
- „ $P = \cdot 32 D$.
- „ $p = \cdot 22 D$.

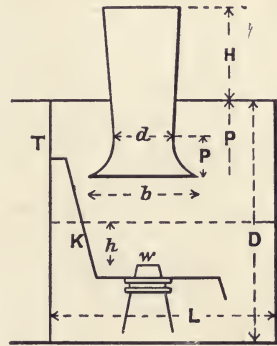

FIG. 53.—Standard front end.

Figs. 54 and 55 are longitudinal and cross sections of the front end of a 4—4—2 Baldwin compound "Atlantic" of great size shown at the St. Louis Exhibition. The grate surface is 49·5 square feet, the external heating surface of the tubes is 3016 square feet, that of the fire-box 190 square feet, and the boiler pressure is 220 lbs. There are 273 tubes $2\frac{1}{4}$ inches diameter and 18 feet 9 inches long. The chimney for this enormous boiler is only $15\frac{3}{8}$ inches diameter at the smallest part, which is just $\frac{3}{8}$ inch larger than the high pressure cylinder. There are four cylinders, two 15 inches and two 25 inches diameter, with a stroke of 26 inches. By the old rules the chimney would have been 25 inches diameter.

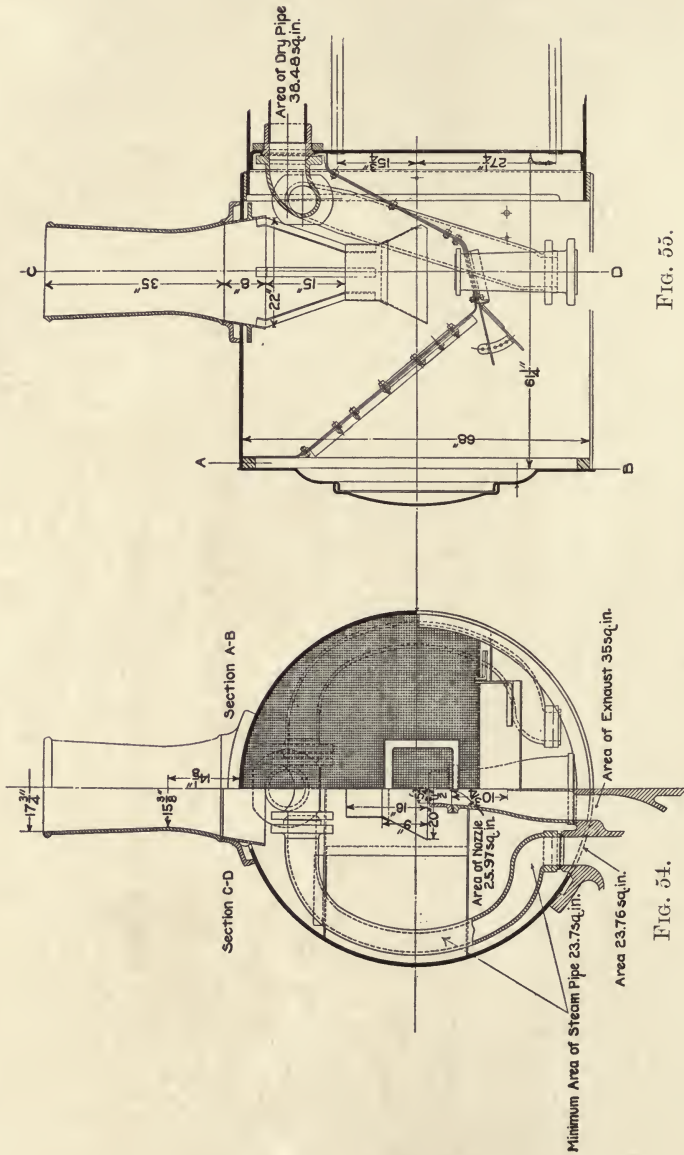

FIG. 55.

FIG. 54.

Baldwin smoke-box.

The diaphragm next the tube plate is of thin iron plate, the remainder of it of stout wire netting as shown in Fig. 55. The gases have to go to the front of the smoke-box before they can reach the chimney.

A few words remain to be said as to the theory of the blast pipe. It has already been explained that the friction of the exhaust steam drags the products of combustion with it, and that, furthermore, they find their way into it and mingle with it. This they do because the jet not only exerts no lateral pressure, having no tendency to expand in the ordinary sense of the term, but because its pressure is actually less than that of the vacuum in the smoke-box, in the same way and for the same cause that the pressure of a fan-blast is always least at the point in the wind-trunk nearest the fan case.

But there is reason to believe that another factor also plays a part, which has been overlooked. If left to itself, the external atmosphere would rush down the chimney into the smoke-box to fill up the vacuum. Now just at the extreme top of the chimney the blast acts to push the air away. Its influence extends indeed for some distance above the stack to form a second vacuum outside the smoke-box, into which the gases, of course, rush. Experiments carried out by Mr. Aspinall go to show that at the very top of the stack a negative pressure equal to as much as 10 inches of water may exist.

The reader has now had placed before him in a succinct form sufficient information to enable him to form a fairly complete idea of the way in which coal is burned in a locomotive. He will have seen that simple things as the putting of coal through a fire hole and the issue of heated gases, steam, and, perhaps, smoke from the engine chimney may appear to be, they are really only the initial and terminal stages of a series of complex processes on the complete working out of which depend the success of the locomotive engine. While the general reader may rest content with what he has learned in this connection, it is hoped that the student will only find that his appetite for further information has been stimulated.

CHAPTER XIX

STEAM

WE have now seen what goes on at the fire-side of the heating surface. We have next to consider what takes place at the water side. Before going further, it will be well to give a short statement of the pressures and temperatures, &c., most commonly met with in locomotives. The reader will, perhaps, scarcely need to be told that the temperature at which water boils bears, so long as the water is pure, an unalterable relation to the pressure. In the accompanying table fractions have as far as possible been

PROPERTIES OF SATURATED STEAM.

Boiler Pressure.	Temperature. Degrees Fah.	Total Heat from Water at 32°.	Latent Heat.	Weight of one Cubic Foot.	Volume 1 lb. of steam. Cubic Feet.	Cubic Feet of Steam to One of Water.
lbs.				lbs.		
150	366°	1193°	856°	·3695	2·71	169
160	371°	1194°	853°	·3899	2·56	159
170	375°	1196°	849°	·4117	2·43	151
180	380°	1197°	847°	·4327	2·31	144
188	382°	1198°	845°	·4431	2·26	141
195	386°	1199°	842°	·4634	2·16	135
205	390°	1200°	839°	·4842	2·06	129
215	394°	1202°	836°	·5052	1·98	123
225	398°	1203°	834°	·5248	1·90	119

omitted, and the nearest round numbers used. The figures refer to what is known as dry saturated steam, that is to say, to steam free from water carried in the form of spray or priming. The pressures given are those which are read on steam pressure gauges, and are not the absolute pressures, which are 14.73 lbs. higher.

The heat produced by the combustion of the coal in the fire-box has to be transferred to the water in the boiler, and to do this it must pass through the metal of the plates and tubes. Precisely how the transmission takes place is not known. In effect, the side of the plate next the fire is made hotter than the side of the plate next the water, and heat goes through; the water side of the plate being in turn hotter than the water, the transmission continues. This is all apparently very simple, but the process is really complex.

It is assumed that the plate resists the transmission of heat through its substance, and that the fact that one material is a better conductor of heat than another is due to variation in the amount of the resistance. Hence, we find it argued that copper plates being much better conductors of heat than iron or steel, they are preferred by astute railway engineers to steel or iron plates. There is, however, no basis of truth in this theory. Steel fire-boxes are almost always used in the United States. They have been tried in this country. Careful experiments, and indeed long-continued practical trials, show that copper possesses no advantage whatever over iron or steel. It is used because it is much more durable than any other material; and when a copper fire-box is worn out it can be sold as old metal at from 50*l.* to 70*l.* a ton, according to the state of the market, while an old steel fire-box will hardly pay the cost of breaking it up.

The efficiency of a fire-box plate does not in practice depend on its conducting powers at all. It does depend on its receiving and emitting powers. It has been shown by Peclet and others that a square inch of copper in a fire-box can "conduct" about twelve

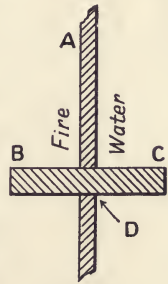

FIG. 56.

times as much as it can absorb or emit. Thus, let A in Fig. 56 be the side of a fire-box, in which is fixed a pin $6\frac{1}{2}$ inches long and 1 inch in diameter. A length B of 3 inches of the pin is in the furnace and a similar length C in the water, and it is a little over $1\frac{1}{8}$ inch in diameter. Its cross-sectional area at D is therefore 1 square inch. The surface which it offers to the fire is 11.6 inches, and that to the water the same. Now, it is impossible to melt the 3 inches of pin in the fire, simply because all the heat that the 11.6 inches of surface can absorb can be conducted through the square inch section of pin in the plate, and the water will take up the heat, provided the pin is clean, and so the pin is kept cool.

A knowledge of this fact led Mr. Charles Wye Williams, a very eminent engineer in the early portion of the last century, to put "heat pegs" in the furnace plates of boilers. He thus very largely augmented their power; but the invention was doomed to failure because it was impossible to keep the pegs clean and free from deposit on the water side, and so plates and pegs were involved in one common ruin.

We may rest content, then, that the transmission of heat has in practice nothing to do with the conducting powers of the plate, while it has everything to do with its emissive and absorbing powers. Now these depend on two factors. The first is the way in which the heat is applied to the plate; the second is the completeness, or the reverse, of the contact of the water with the plate.

It may be stated without fear of contradiction that the best results will be got when the flame or hot air impinge directly on the plate to be heated, that is to say, the flow of the products of combustion ought to be at right angles to the surface. The impingement of the flame leads, furthermore, to a breaking up and mixing of columns or bodies of hot gas. The parallel flow of hot air or even flame along a surface to be heated is not so effective. This is no doubt one reason why a tube plate does so much work, the products of combustion strike it directly when rushing to the tubes.

All this holds good to a still greater extent as regards water,

Water is to all intents and purposes a non-conductor of heat. Any quantity of it can only be heated throughout by convection, that is to say, only the film in immediate contact with a hot plate is heated. Fortunately, water expands, and the hotter water being lighter than the cold rises, and is replaced by cold water, which is in its turn heated. This process is termed convection. It may be taken as certain, that unless every drop of water in a boiler comes into contact either with the heating surface or with steam, it will remain cold. Water, it is well known, cannot be raised in temperature from above downwards. In marine boilers the heat is always supplied at a height of at least 3 feet above the bottom of the boiler. The result is that steam may be up and the engines at work for an hour or two while the water at the bottom of the boiler is quite cold. This stresses the boiler plates severely, as the plates in the steam space are expanded by the heat, while the bottom plates are not. The rolling and pitching of the ship at sea sets the water in motion, and so equalises temperature. But it is the custom nowadays to use what is known as a "hydrokineter," which is simply a jet nozzle near the bottom of the boiler. A pipe from the steam space leads down to this, and as soon as steam is up to ten or twelve pounds pressure it is sent through the jet into the cold water, where it condenses and heats up the stagnant water, putting it in motion at the same time. In large vessels, as steam is always up in some one boiler to supply electric light, &c., steam of full pressure is taken from this and blown into the bottoms of the other boilers as soon as the fires are lighted. In the locomotive it is true that there is no stagnant water; none the less does the incapacity of water to conduct heat play a very important part, as will be understood in a moment.

Reference has been made to Mr. Charles Wye Williams, who, it may be added incidentally, was one of the first to make Atlantic steam navigation a success. He was a most competent authority on boiler furnaces and the prevention of smoke. In the year 1860 he published a very curious book, in which he set forth the theory that water can never be heated at all. The application of heat at once transforms it into steam, and this steam is diffused

through the main body of the water, just as carbonic acid gas is in a bottle of "soda water." A thermometer put into the water is heated by the steam in it. It may be said of this theory that it is very difficult to disprove it—a difficulty augmented by the circumstance, already pointed out in a preceding chapter, that no one knows anything with any completeness of knowledge as to how water is converted into steam, or the true difference between dry saturated steam and water.

It will be seen from what has been said that a steam boiler cannot be worked without circulation. Thus we find that the claims of various inventors of boilers always include a statement that the "circulation is excellent," or "the best possible," or "violent." In point of fact, circulation is really a curse instead of a blessing, but it cannot be done without. In the locomotive boiler good circulation is essential not only to success, but to safety. The heating surface must be kept wet, that is to say, the water must be in direct contact with it at all times. If the crown sheet of the fire-box of a locomotive, with a heavy fire on, became dry, about thirty seconds would suffice to make it red hot, when it would be so weakened that it would collapse, with the most disastrous results.

Now, so long as the boiler is kept sufficiently full there will be two or three inches of water over the crown sheet, and as there is free access to it from the boiler barrel, and the steam generated can rise straight from it, we seldom hear, if the water is good, of the failure of this plate. But the case is entirely different with the "water legs," that is, the space round the bottom of the fire-box, and with the tube sheet. It has already been explained that at the sides of the fire-box the space filled with water is sometimes only $2\frac{1}{2}$ inches wide, seldom more than $3\frac{1}{2}$ inches. This is the portion of the fire-box in direct contact with the burning fuel. The ebullition in these narrow water spaces must be very violent, the access of water to them not easy. They are in point of fact full of a mixture of steam and water in the condition of foam rather than of solid water. The plates are no doubt in a constant condition of over-heat, and it is not surprising that cracking and buckling and deformation of the plates between the

stay bolts should be rife. Water legs should never be less than 4 inches wide. The attempt to make the grate a little wider by narrowing the water legs is a mistake.

As to what really takes place in the water-legs, some direct information exists. In the course of a paper on "Large Locomotive Boilers," read by Mr. G. T. Churchward, Chief Mechanical Engineer of the Great Western Railway, he said that, "with modern high pressures, the rate of evaporation is so much increased that the provision for circulation which was sufficient for the lower pressures formerly used, is doubtless insufficient." The general theory is, that cold water being put into the barrel near the front end, sinks to the bottom under the tubes, and flows back, entering the "water-legs," and passing round the back of the fire-box where it rises and flows over the top of the box forward. Mr. Churchward's experiments showed that in the main this view was accurate, but a little alteration in the firing has the effect of changing the direction of the currents and even of reversing them. This is a fact of much greater importance than appears at first sight. It is one explanation of the extraordinary way in which a small mistake in firing may cause loss of pressure in a hard-pushed boiler.

The tubes are spaced at distances varying between $\frac{3}{4}$ inch and $\frac{5}{8}$ inch, according to the views of the designers. When it is considered that the temperature at the tube plate is probably the highest in the fire-box, it is easy to understand that here again we have a place in which it is impossible for "solid" water to exist. It is in this way that the constant liability of tubes to leak can be explained. It may, then, be accepted as a deplorable fact that until we get to a point a couple of feet forward in the barrel, nothing but a mixture of steam and water is available to keep the plates from being overheated. The condition has to be accepted; but it is responsible for rapid wear and tear, which add largely to the cost of maintaining locomotives in good order.

CHAPTER XX

WATER

So far all water has been spoken of as though it was invariably equally good and suitable for a locomotive boiler. But not only is this not the case, but water which will answer very well with pressures of 150 lbs. may be quite unfit for boilers carrying 200 lbs. It is almost impossible to command a supply of pure soft water all over a great railway system. Nearly all the water available is more or less "hard," that is to say, it carries salts of lime, or magnesia, or both in solution. Now unfortunately these salts are more soluble in cold than in hot water, and the result of raising the temperature is to cause the deposit of the lime on the heating surfaces. The boiler of the locomotive becomes "furred" like the inside of the domestic tea-kettle. The lime is not only an exceedingly bad conductor of heat, but there is reason to believe that its emissive powers are also low, and a very moderate thickness of it accumulated on a fire-box plate will secure the overheating and more or less rapid destruction of that plate. It is held by some persons that if the circulation is rapid, deposit will not have time to attach itself to the metal. This is, but only in a very small way, true. It holds good of water-tube boilers—provided the tubes are short in proportion to the diameter, and the water is not heavily charged with lime; but there is no circulation round a locomotive fire-box powerful enough to save the situation. The true way out of the difficulty lies in getting rid of the lime before it enters the boiler. On a few railways, however, much good has been done by change of water. Thus, when locomotives are worked for some time in a district where the water is bad, they are then sent to another district where the water is soft and good. In

two or three days the deposit will be loosened by the soft water and can be washed out as mud. Locomotive boilers are always washed out at intervals of two or three days, or a week, or even more, according to the quality of the water, as will be explained when the daily life of an engine is dealt with.

A long account of the chemistry of water-softening would be quite out of place here. It will be enough to say that lime is kept in solution in the water by the presence of free carbonic acid, CO_2 . If now more lime is added, the acid is neutralised and the whole of the lime, namely that originally in the water and that added, are thrown down together in settling tanks. Various systems are employed.

The general principle of neutralising free carbonic acid must be modified in various ways to suit special conditions. What will do very well for the treatment of the water supply of a large town, where space for filtering tanks and plenty of time are available, will not suit railways. Lime must be supplemented, usually with caustic soda or soda ash, and the water must be heated to secure rapidity of action. The system devised by Messrs. Archbutt and Deeley, and used on the Midland Railway, may be taken as typical. The process is completed in about three hours, so that only comparatively small settling tanks are required. The water is sent in by an injector and mixed with a solution of slacked lime and soda ash which have been boiled together. Air is blown by another injector through a series of perforated pipes at the bottom of the tanks which effects a thorough mixture, not only of the reagents, but of the mud left in the tank with the fresh water. This mud seems to cling to the new deposit and carry it down to the bottom of the tanks as soon as the blowing in of air ceases. The softened water is drawn off from the surface by a floating delivery pipe, and has subsequently a small quantity of carbonic acid from a coke fire blown into it, to prevent any trifling percentage of lime which may remain in the water from settling in the feed-pipes or injector nozzles of the engines. From time to time the sludge which accumulates in the tanks is cleared out.

In some cases where the water is fairly good much benefit is

derived from putting a few pounds of caustic soda into the tender tank every day. Quite a small quantity suffices to render the deposit in the boiler soft, so that it can be readily washed out.

Assuming that the water is sufficiently purified, we have next to consider what is the best way of putting it into the boiler. This does not refer to the pump or injector by which the feed water is forced in—apparatus which will be dealt with further on—but to the locality of its introduction. The following statement, made by Mr. James Stirling at a meeting of the Institution of Mechanical Engineers, in the course of the discussion on Mr. Churchward's paper on "Large Locomotive Boilers," read in February, 1906, covers most of this ground and is highly suggestive:—

"With regard to feed-water, he believed he had fed water into locomotive boilers in almost every way possible to think of. He had delivered it through the smoke-box tube plate, sending it straight back to the fire-box under the impression, as was natural, that the ebullition being most violent at the top of the fire-box and in the immediate neighbourhood of the tube plate, that the current of water must necessarily flow to the smoke-box end and come back to the fire-box under the tubes; the results were very satisfactory as to steaming. The next thing was to deliver the water over the top of the fire-box in front of the tube plate, but that only created fouling of the tubes where they could not be got at in washing out. He then fed the water in at either side of the fire-box, with the result that all the stays began to leak forthwith. The next and the last thing was to feed the water in the old-fashioned place, namely, in the side of the first plate from the smoke-box of the boiler, and he there had a command of the fouling, and could get the hose-nozzle at it on washing-out days and clear it away; in that way he managed to keep his boilers fairly clean. Those dealing with locomotive boilers knew that the moment the water reached the heat it immediately precipitated any lime or deleterious matter that might be in it."

If cold water is sent into a boiler it can do much harm by

setting up local contractions, and so causing leakage. That is the explanation of the fact stated above, that when the feed was put in at the sides of the fire-box the stay bolts leaked. An attempt is often made to raise the temperature before the water enters the boiler, both to save the plates and to economise fuel. As far back as 1850 a pipe was carried from the boiler to the bottom of the tender tank; when steam began to blow off at the safety valve, a cock in this pipe was opened and the steam blown into the tank, thus raising the temperature of the feed water and avoiding waste. Subsequently Mr. Stroudley turned a portion of the exhaust steam into the tender. Mr. Drummond has a special apparatus for this purpose, the description of which must be postponed until tenders are dealt with.

The injector, which will be described presently, always raises the temperature of the feed. Sometimes the feed pipe is carried along inside the boiler for several feet, the temperature of the feed water inside rising within it. The true solution of the difficulty, however, lies in sending the feed water into the steam space as spray. It can then exert no chilling effect, and much if not all the lime will be deposited as a fine powder which can be washed out. Experiments made in this direction have been quite successful. There is, however, what may be termed a popular delusion that if cold spray were turned into the steam space it would at once condense all the steam. This is quite a mistake. A small quantity of steam would undoubtedly lose its heat, but the boiler would at once replace the steam condensed, and the net effect on the quantity of steam available for the engines in any unit of time will be the same, whether the cold water goes into hot water or into the steam space. An equally grave error is based on an erroneous theory of the injector, according to which the injector cannot send water into steam. It will be shown further on that the injector will work equally well no matter into what the water is forced. Mr. Churchward has been carrying out experiments on the Great Western Railway on the introduction of feed water into the steam space; certain constructive difficulties have been encountered, but nothing affecting the soundness of the principle.

CHAPTER XXI

PRIMING

NOTHING has been said so far about the quality of the steam. To the general public no doubt all steam is the same. But the engineer understands that the quality of steam has a wide range. Good steam is almost entirely free from water and dirt, and can only be had from clean water, heated in a clean boiler. Bad steam is wet—"priming" goes on in the boiler. The water in the boiler is dirty, and so is that in the steam—doubly or trebly dirty. The steam may carry with it fine mud, fine sand, now and then hard lime, which has a disastrous effect on the engines. But even when the water is clean, if a boiler is hard pressed priming may take place, and to such an extent that the trains cannot keep time. The causes of priming are very imperfectly understood. A small quantity of oil or grease in the feed water will make the water "foam," and priming will go on until the grease has been got rid of. On the other hand, in the old days before surface condensers were used, and marine boilers were fed with sea water, syringes were carried which could be screwed on to small clack-valve boxes near the water level, and melted tallow was forced into the boiler which was giving trouble, and almost always stopped the priming.

Although a clean boiler will not prime, the water always lifts in a locomotive boiler while the throttle valve is open. It is for this reason that while a locomotive is running, the glass water gauges are almost always full to the top. When steam is shut off ebullition ceases at once for the time, and the water falls a couple of inches. The steam space in a locomotive is restricted, and two different systems are used to get dry steam. According to the first, the entrance to the pipe which supplies the cylinders

is placed as far above the level of the water as possible in a dome on the top of the boiler. According to the second system, the steam pipe runs the whole length of the barrel of the boiler, quite close to the top, and in the top of the steam pipe are drilled small holes, or else a number of transverse cuts are sawn in it, through which the steam has to enter, the rear end of the pipe being stopped up by a plug screwed in. In this way the steam being drawn not from one spot, but from, so to speak, the whole steam space, the lifting of the water is diminished, and the steam kept dry. The perforated pipe has, however, gone out of use, not so much because it was inefficient as because the regulator or throttle-valve box has to be placed in the smoke-box, where it is not wanted, and is indeed very much in the way.

It may be asked, How is it known that a boiler is priming? When the priming is profuse there can be no doubt about it, because hot water is blown through the cylinders out of the chimney. But there are all degrees of priming, from a fraction of 1 per cent. up, and a good deal of ingenuity has been expended in devising means of measuring the amount of pure water in any stated volume of steam. It cannot, however, be said that the results are quite satisfactory. In point of fact, the precise estimation of water, or degree of wetness of steam, is very far from easy, because a great many chances of error have to be guarded against. Three different methods have been tried. The first and simplest consists in putting a good deal of salt into the boiler, and then condensing a known weight of steam drawn from the main steam pipe. If the boiler primes it must prime salt water. The water resulting from the condensation of the steam is evaporated in a shallow pan, and the salt left at the bottom is weighed. A simple calculation too obvious to need stating then gives the percentage of water in the steam. The fundamental objection is that the presence of the salt may itself set up priming, and is besides bad for the boiler. A refinement of the process consists in using very little salt and adding to the condensed steam in a test tube a solution of nitrate of silver, which if salt be present gives a curdy or flocculent deposit. The

system has been used to a limited extent with water-tube, but never with locomotive boilers.

The second system seems to have been first used some thirty years ago by Mr. Barrus, an American engineer. The principle involved is very simple. The total heat in a pound of steam is much greater than the total heat in a pound of water of the same temperature. If now we turn any known weight of steam into cold water the temperature of the water will be raised, and the drier the steam the greater will be the rise in temperature. Thus the total heat in one pound of steam at an absolute pressure of 165 lbs.—boiler pressure 150 lbs.—is 1192·9 from water at 32° F. and the total heat in water of the same temperature is 366°. Now if we condensed one pound of steam to water at 32°, 1192·9 British thermal units would be given up. If we cool down one pound of water through the same range of temperature, 366 thermal units will be given up, and any mixture of the water and the steam will give up less than the one and more than the other. So if we mix one pound of steam with one pound of water the total available heat will be $1192·9 + 366 = 1529$ units, whereas if the two pounds of fluid drawn from the boiler had been pure dry steam there would have been 2,386 units available. All we have to do then, is to ascertain how much less than 1,193 units is given up by each pound of steam drawn from the boiler, and a very simple calculation will give the percentage of water present.

In practice a small wooden cask is placed near the boiler on the platform of a weighing machine; in the cask is a known weight of water. The temperature is taken by a thermometer. Communicating with the boiler or the main steam pipe is a tube fitted with a stop cock. To the end of this tube is attached a piece of india-rubber piping. All being ready, and weights being placed in the scale to overbalance the cask and its contents by a certain amount, steam is blown through the pipe to warm it up and clear it of condensed steam. The end of the india-rubber pipe is then plunged into the water in the cask and steam is allowed to flow until enough of it, say 5 lbs. or 10 lbs. or 20 lbs., has been condensed to turn the scale. The

steam cock is then closed. The rise in temperature and the increase in weight are carefully noted, and a simple calculation gives the percentage of priming. An improved form of apparatus was devised by Mr. Barrus, but the chances of error are so great that it is impossible to regard the results as certainly correct within 3 per cent.

The Barrus system has been entirely superseded by the throttling calorimeter invented by Mr. Peabody, also an American engineer, which with care will give very accurate results. It depends for its action on entirely different phenomena.

If the reader will turn to the table of the properties of steam given on page 152, he will see that as the pressure and temperature rise, so does the total heat, only very much more slowly. Let us take, as before, our pound of pure dry steam at 165 lbs. Its total heat we have seen is $1,193^{\circ}$ F. Let now this steam fall in pressure, without doing any work, to that of the atmosphere = 14.7 lbs. Its temperature will then be 212° F., and its total heat $1,146^{\circ}$ F., and we have $1193^{\circ} - 1146^{\circ}$ F. The difference is 47° . What becomes of this? Rankine was the first to show that if the steam contained no free water the 47° F. would superheat it. We may further deduce that if it did contain water then that water would be all converted into steam unless there was too much of it. If the reader has followed so far he will have no difficulty now in seeing that it is only necessary to take the temperature of the steam before and after the fall in pressure to ascertain the percentage of water present. As the specific heat of steam, that is to say, the quantity of heat required to raise it one degree Fahrenheit in temperature, is to that of water as .48 to 1, the 47° available would raise the temperature of one pound of steam by nearly twice as much.¹ The calorimeter in its most improved form is illustrated by Fig. 57.

The steam is allowed to expand without doing any work by

¹ The true value of the specific heat of steam cannot be regarded as settled; inquiry is still proceeding. There is reason to believe that it varies with the pressure. The figure given is, however, quite accurate enough for the present purpose.

passing through a small orifice in a thin plate at I. The main steam pipe is shown at G, and the collecting pipe at F. It enters the steam pipe as shown, and much discussion has taken place as to the best way to admit the steam into F. With this we need not concern ourselves. A is a so-called drip box, which is intended to remove some of the priming water if it is plentiful. This is collected and measured, its height in the drip box being

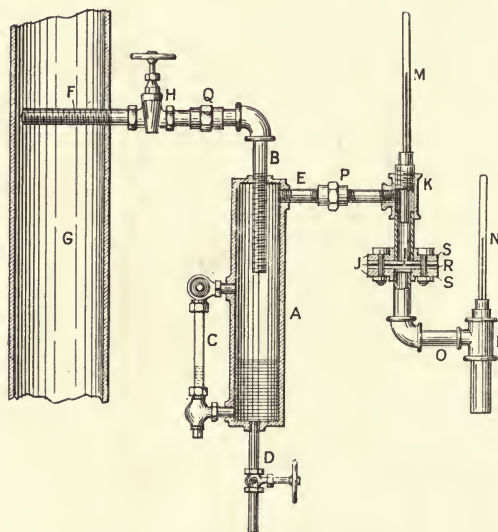

FIG. 57.—The Peabody calorimeter.

shown by the glass water gauge C. The discharge cock is shown at D. The steam passes from the top of the drip box by E P into K, into which is screwed the thermometer M. The thin plate is shown by R. J and S are flanges between which R is bolted. The expanded steam passes through O into L and thence into the atmosphere. N is a thermometer similar to M. The difference between the reading of the two thermometers expresses the quality of the steam, in other words the percentage of water in it. It is not necessary to give here a general equation. In practice, nothing in the way of an elaborate calculation is

necessary. Mr. Barrus gives in Vol. XI. of the Transactions of the American Society of Mechanical Engineers the following instructions for using this instrument:—

“In order to compute the amount of moisture from the loss of temperature shown by the heat gauge, the number of degrees of cooling of the lower thermometer (N) is divided by a certain co-efficient, representing the number of degrees of cooling due to 1 per cent. of moisture. This co-efficient depends upon the specific heat of superheated steam, which, according to Regnault’s experiments, is 0.48. In other words, the heat represented by 1° of superheating is 0.48 of a thermal unit. This quantity cannot be applied exactly to the form of instrument under consideration. The quantity to be used varies somewhat according to the degree of moisture. For an instrument working under a temperature of 314° F., by the upper thermometer, and with a cooling by the lower thermometer from 268° to 241°, the quantity was found to be about 0.42. When the cooling, however, was from 266° to 225°, the quantity to be used was found to be about 0.51. The experiments have not as yet covered a sufficient range to determine the exact law which can be applied to every case, but it seems probable that the specific heat is more or less constant until the temperature by the lower thermometer approaches the point of saturation for the low pressure steam, while beyond this point the specific heat rapidly increases. For the present, it is assumed that the quantity 0.42 is the proper one to apply whenever the temperature by the lower thermometer is above 235°, and that in cases where the temperature is below 235°, the quantity to be used is an increasing one, reaching perhaps to 0.55 when the temperature drops to 220°.

“One per cent. of moisture now represents the quantity of heat determined by multiplying the latent heat of one pound of steam, having a pressure corresponding to the indication of thermometer M, by 0.01, and this product is to be divided by 0.42 (provided the lower temperature is not below 233°) in order to express it in terms of degrees of superheat. For example: when thermometer M shows 312°, the latent heat is 894 thermal units, and 1 per cent. of this is 8.94; dividing

by 0.42, the number of degrees of superheat corresponding to 1 per cent. of moisture is found to be 21.3. For several other temperatures, which cover the ordinary range that would commonly be used, the necessary co-efficient is given in the following table:—

Temperature by Thermometer M.	Co-efficient.	Temperature by Thermometer M.	Co-efficient.
270	22.0	320	21.1
280	21.8	330	21.0
290	21.7	340	20.8
300	21.5	350	20.6
310	21.3	360	20.5

Certain corrections have to be made for radiation from the calorimeter itself, and curiously enough it has been found that when the steam is very wet so much water remains in the drip box that the steam going into the instrument proper is actually drier than is steam which does not deposit any sensible quantity in the drip box.”

CHAPTER XXII

THE QUALITY OF STEAM

WE may now turn to the results obtained in practice from the modern locomotive boiler as ascertained by the calorimeter. In this country nothing has been done in this way. Indeed, the only information on this point which covers a sufficiently wide range of locomotives has been supplied by tests carried out at the St. Louis Exhibition of 1904, to which reference has already been made in these pages. The importance of the figures will be better appreciated when we come to deal with superheating and its effects on the economical efficiency of locomotives.

It is very constantly assumed that locomotive engine boilers do not supply dry steam. That is to say, it is asserted that it never contains less than 5 per cent. of water. The St. Louis experiments do not bear out this proposition. In all eight engines were tested; of these four were passenger and four were goods engines. The following table gives the results of tests made with the Peabody throttling calorimeter just described:—

Loco. Number.	Maximum.	Minimum.
GOODS.		
1499	·9903	·9877
734	·9871	·9837
929	·9846	·9445
585	·9845	·9828
PASSENGER.		
628	·9986	·9936
2512	·9859	·9812
3000	·9835	·9499
585	·9823	·9626

The decimals express the percentage of steam in ten thousand parts of the mixture of steam and water supplied by the boiler. The maximum percentage of water, it will be seen, is about 5·5, the minimum a shade over 1 per cent. It must not be forgotten that these results were obtained from very dissimilar boilers working under dissimilar conditions, and, therefore, may be taken as thoroughly representative. But it must also be kept in mind that the boilers were very clean, and were supplied with water of excellent quality.

A complete explanation of the causes of priming has not yet been framed; why, for example, dirty water should prime and clean water will not is not known.¹ The theory of the matter is that surface tension has something to do with it. This means that the bubbles of steam have a comparatively tough envelope of water, which rises through the main body. When the bubble bursts this water is scattered in all directions, and remains suspended in the steam. Again, when water is boiling in an open vessel it will be seen that a multitude of little fountains of spray rise from the surface and fall back again. The water in these may be readily entrained and carried away by the steam if there is a strong current moving in any particular direction, as, for example, to the opening of the regulator.

¹ Water-tube boilers supplied with pure clean rain water will prime, and with distilled water will not. Locomotive type boilers supplied to H.M.S. *Polyphemus* primed so much on board that they had to be taken out. They were worked with water from surface condensers. They were subsequently put up on land and used for driving dockyard machinery with similar water, and gave no trouble whatever. Abundant examples of the capriciousness of boilers could be supplied.

CHAPTER XXIII

SUPERHEATING

A CONSIDERATION of how far, and in what way, the economical and absolute efficiency of a locomotive are affected by the quality of the steam must be postponed until we come to deal with the engines. It is open, perhaps, to question whether superheaters are part of the boiler or part of the engine. The author holds it to be most convenient to adopt the first view, and to regard all that affects the quality of the steam as delivered to the engine as part of the generating apparatus.

Before describing superheaters it is necessary to explain what they are intended to do.

It will be understood from what has gone before that saturated steam is an unstable fluid. It is not easy, indeed, to realise how unstable. It is always on the point of reverting to its original condition of water. Now, when any percentage of a given weight of steam liquefies it surrenders all its latent heat, and if only the heat could be utilised, then liquefaction might do very little harm. It can be shown, however, that such utilisation does not take place in practical work; and it becomes expedient, therefore, to impart stability to the steam. If we reduce the temperature of dry saturated steam by withdrawing heat some of it will condense. If, however, the steam possesses a sensible temperature greater than that due to its pressure, then no condensation can take place until such a time as the whole of this additional temperature has been withdrawn. Thus, let us suppose the case of one pound of steam, with an absolute pressure of 165 lbs. per square inch. Its temperature is 366° F., the total quantity of heat in it is 1,193°, its volume is 2.71 cubic feet. If now we withdraw nominally one-tenth of the total heat, then

one-tenth of the steam will be reduced to the condition of water, and so on. But 0·1 means 119°, omitting fractions. If, however, we had added to the steam beforehand the equivalent (depending for its amount on the specific heat) of 119°, then the withdrawal of one-tenth might take place—there would be a reduction in temperature, but no condensation. This is the principle on which the value of superheating depends.

The figures given above must be regarded only as illustrative, for the conditions of superheating are much more complex than may appear at first sight. Thus, one of the immediate effects of superheating is to increase the volume of the body of steam superheated¹; it has been shown by Fairbairn that the volume augments much more rapidly at first than it does subsequently. One explanation of this fact is that the water suspended in the steam is evaporated first and that the steam so produced goes to add to the volume, and that once that has been effected, expansion takes place purely as if the steam were a gas. Again, as has been already pointed out above, considerable uncertainty exists as to what the precise specific heat of steam gas is. Probably it is about 48°, or rather less than one-half that of water. The specific heat of dry saturated steam is 305°, that is, the quantity by which the total heat of saturated steam is increased for each one degree of added temperature. The expression 305 is used in a compound sense, taking account as it does of the changes both of volume and pressure which take place in the generation of saturated steam. Regnault's experiments gave the specific heat of steam-gas—that is to say, of steam out of contact with water in any shape—as 475 under constant pressure, or upwards of one-half more than that of saturated steam. Recent researches, however, seem to prove

¹ A sharp difference of opinion exists among engineers as to whether the increase of volume has or has not any economic value. On one side it is maintained that such a reduction of temperature always takes place in the engine that the increase of volume disappears; on the other, an eminent authority, Dr. v. Garbe, of the Prussian State Railways, and the apostle of the Schmidt system, maintains that superheating, or, as he calls them, "hot steam, locomotives," must have larger cylinders than saturated steam locomotives in order to utilise this augmented volume.

that the more correct co-efficient is $\cdot48$. To complete this statement, Rankine lays it down that the total heat required to convert a given substance from a state of great density at a given temperature, T_0 , to the perfectly gaseous state at a given temperature, T_1 —the operation being completed under any constant pressure—is given by the equation

$$h = a + c^1 (T_1 - T_0),$$

where a is a constant and c^1 is the specific heat of the substance in the perfectly gaseous state under constant pressure. Thus, to convert one pound of water at 32° into steam-gas at 212° requires $\cdot1092 + \cdot475 \times 180 = 1,177$ units of heat, being more than the quantity required to make saturated steam in the ratio $\frac{1,177}{1,146} = 1\cdot028$. Here $a = 1,092$ and $c^1 = \cdot475$.

The principal utility of these equations lies in showing how much heat must be added to steam to convert it into a comparatively stable gas. In so far as regards the locomotive, however, their value is in the main academical; because, in the first place, heat which would otherwise be wasted is supposed to be utilised, and because, in the second place, the results obtained in practice do not bear any traceable relation to the figures given. The conditions are far too complex to permit such relations to be established. In a word, superheating has hitherto been carried out by rule of thumb, derived from rough experiments. The general result is that no matter how the superheating is effected, the hotter the steam the better in so far as economy of fuel is affected. As to its effects on rubbing surfaces in the engine, that is another story to be told further on.

Although various methods of superheating have been devised and even patented, there is only one in use. The steam flowing from the boiler to the engine is made to pass through pipes in which its temperature is raised. Now it so happens that while wet steam will absorb heat rapidly, dry steam will not. Indeed, it is by no means easy to superheat steam beyond some 30 or 40 degrees. To make the superheating apparatus worth having, however, the temperature of the steam should be raised at least

200 degrees, so that 150 lbs. boiler steam must have a temperature of $366^{\circ} + 200^{\circ} = 566^{\circ}$ F. But Schmidt wants much more than this; he likes 650 to 700 degrees. Where on a locomotive engine can space be found for the required pipes? Here the inventor comes in. Four or five different systems have been tried. Of these only one appears to have come as yet into anything like regular use, namely, the Schmidt. Several others are still in the experimental stage—the Notkin, American, Cockerill, Cole & Vaughan, and Horsey may be mentioned. It will suffice if we confine our attention to the system first named, because so far it is the only one in regular use. It was introduced by M. Schmidt on the Prussian State Railways as far back as 1898. Originally the place of a number of the lower flue tubes was taken by one large tube about a foot in diameter. In the smoke-box were fitted at the sides inverted U-tubes. These were cut off from the smoke-box by partition plates. The steam was taken in at one end of the U-tubes and delivered to the engine from the other end, superheated by the hot gas passing through the large tube, and rising at each side to the top of the smoke-box and thence up the chimney. The arrangement was not very successful, and has been superseded by one quite different.

This cannot be better described than in the words of Herr Robert Garbe, Chief Mechanical Engineer of the Prussian State Railways, who has recently dealt with the whole subject in a series of articles contributed to the *Engineer*. It will be seen from Figs. 58, 59 and 60 that the ordinary small tubes in the upper part of the barrel of the boiler are replaced by two or three rows of larger size. In the figures there are three rows of eight tubes of 4.88 in. internal and 5.23 in. external diameter. Within each of these are four smaller tubes spaced at equal distances, connected together at their fire-box ends by cast steel return bends to form a single continuous passage, so that the steam passes four times along the length of the superheater tubes. Near the fire-box the outer tubes are contracted to 4.48 in. to allow of a freer movement of the water near the tube plates, into which they are expanded in a special way. The ends of each

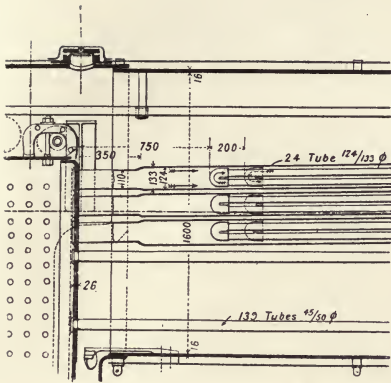

FIG. 58.

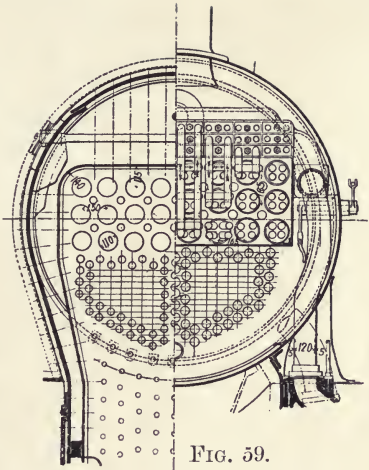

FIG. 59.

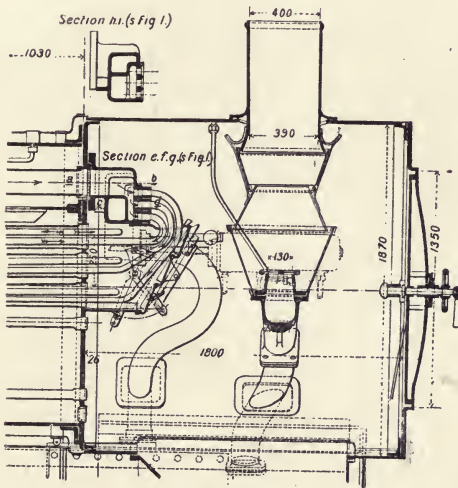

FIG. 60.

The Schmidt superheater.

group of superheater elements on the smoke-box side are expanded into flanges, which are connected to the steam collecting box by screwed joints arranged either horizontally or

vertically, the joint being made tight by copper asbestos packings. The former arrangement involving a semicircular return bend for the superheater tubes, has the disadvantage of requiring an extra long smoke-box, but as it causes a better utilisation of the heat it is retained on the Prussian lines up to the present. The cast iron superheated steam collector, Fig. 60, which is made of the same metal as the cylinders, is so divided and connected with the boiler and the valve chest that the steam from the former must pass through the whole of the superheater system before reaching the engine cylinders. The fire gases being divided between the lower normally arranged boiler tubes and the larger upper tubes containing the superheaters, give up their heat partly to the surrounding boiler water and partly to the steam circulating in the superheater. The regulation of the flow of the gases through the superheater is effected by a system of dampers, which are kept open by steam pressure as long as the regulator valve is open, but are closed when the latter is shut either by a spring or a counterweight. When the engine is standing or running without steam the flame is entirely diverted from the superheater tubes, which would otherwise become red hot. The position of the dampers can also be varied while the engine is under steam by a hand wheel and rod on the footplate, so that the superheating may be regulated independently of the automatic arrangement. The latter, placed outside the smoke-box on the left-hand or fireman's side, is a small steam cylinder whose piston is connected by levers with the damper flaps. There is a pipe connection between the valve of the small piston and the valve chest, so that when the regulator is open and steam is admitted to the cylinders the piston travels forward, opening the dampers, which are closed by the counterpoise as soon as the pressure is taken off by the closing of the regulator.

The removal of soot and ashes from the large smoke tubes may be most readily effected by steam or compressed air either from the fire-box or the smoke-box, but preferably from the former. As a rule, air at ten atmospheres is the best cleaning agent both for these and the ordinary boiler tubes. If

steam is used the cleaning should be done while the boiler is still hot.

The Notkin superheater is very similar in all respects, except that instead of using very elongated U-tubes the inventor employs two concentric tubes, placed in special fire tubes 3 inches in diameter. The outer concentric tube is secured to one half of a steam chest and the inner tube to the other half. The steam passes down the annular space between the two tubes from one half and returns up the centre tube to the other half of the steam chest, whence it goes on to the cylinders.

The Pielock superheater, so called after the inventor, has been fitted to locomotives on the Royal Prussian Railways, and been tried in the United States. It consists of a steel chamber placed in the barrel of the boiler far enough forward to prevent the tubes being overheated. Into the ends of the box the boiler tubes are made tight by rolling them, the expander being placed at the end of a long steel staff which passes down the tubes. It is not necessary that much care should be taken to make the joint tight, as the pressure is nearly the same inside the superheater and outside. It is only required that the water shall be kept out. The box is divided inside by diaphragm plates parallel to the tubes in order that circulation may be secured inside it. The steam is collected at the top of the dome, passes down into the superheater, and then rises again to the regulator valve box and thence to the engine. The total heating surface taken inside the tubes in a normal locomotive is 1,753 square feet, the total heating surface of the superheater inside is 283.79 square feet or .16 of the whole tube surface. At the St. Louis Exhibition, the quality of the steam, before it entered the superheater at all, was excellent, the moisture never exceeding one half per cent. The lowest superheat was 161° F. and the highest 192° F. Curiously enough, the amount of superheat did not seem to be much affected by different rates of combustion or evaporation. The explanation is that when more steam was passed through the superheater the fire was hotter and, of course, the gas in the tubes. As the steam pipe from the superheater passed through the boiler the temperature of the steam

was reduced. It is clear, therefore, that there was loss of heat before the steam reached the engines. The Pielock superheater is fairly efficient, but it is argued about it that on the whole as much in the way of evaporation is lost as the superheater can gain. The more cogent argument against it is said to be the fact that the flue tubes are liable to rapid corrosion inside the superheater.

It was not to be supposed that such an innovation as superheating would be accepted without question, and very keen discussions have taken place concerning not only the respective merits of various systems, but the theoretical and actual value of superheating. When superheating was first proposed in locomotives it was maintained that the heat which was wasted up the chimney could be utilised and in this way superheating could be had for nothing. It was very soon stated, however, that a smoke-box temperature of at the most 700 degrees could not raise the temperature of the steam to anything like the necessary amount.¹ Therefore, as has been shown, in the preliminary Schmidt heaters, a large proportion of the gases was conveyed through a flue tube of considerable diameter to the smoke-box. This did not answer, and now nearly all locomotive superheaters save the Pielock differ from each other only in details. Into enlarged flues are put small pipes, one end of each pipe receiving steam from the boiler, the other end delivering steam to the engine. No waste heat is utilised. The steaming power of the boiler is diminished because the heating surface of large flue tubes is less than that of the more numerous small tubes which could be put into the same space. As, however, the economic efficiency of a boiler is, other things being equal, measured by the smoke-box temperature, and this does not appear to be augmented by the presence of a superheater, it may be taken for granted that the only loss incurred will be in the ability of the boiler to make steam. This means that an engine with a superheater would

¹ It is however claimed that the Baldwin smoke-box superheater raises the temperature as much as is really necessary with the waste gas only. The claims made are so conflicting as regards the temperature which represents all-round maximum economy that the author reserves all expressions of opinion on the point.

not be able to draw trains as heavy or as fast as it would be without the superheater, although the cost of coal per ton per mile might remain unaltered. On the other hand superheated steam being more efficient than ordinary steam, the balance is restored, the power of the engine is increased, and an economy of fuel effected. How much, remains a bone of contention among railway engineers, the dispute being strengthened by the lack of uniformity in results obtained on different railways. In this country, very little has been done, because it is maintained that the large addition to the first cost of the locomotive, and the heavy expenditure on the upkeep of an apparatus so liable to wear and tear and corrosion cannot fail to neutralise much of the economical advantage that it may be able to bestow. So far the experience obtained on Continental lines has not been regarded as convincing. The size of the smoke-box, too, is increased, as is the weight on the leading bogie. The kind of work done in this country is different in many respects from that performed by Continental locomotives. Our coal is very much better, and on the whole, cheaper ; and lastly, we have the somewhat sentimental objections held by British engineers to anything savouring of complications, which are for the most part favoured rather than condemned in Europe.

CHAPTER XXIV

BOILER FITTINGS

WE come now to the several adjuncts or appurtenances with which the boiler is fitted. Although these always serve the same purpose they vary widely in design and the details of their construction. None of them, perhaps, is so obvious to the railway

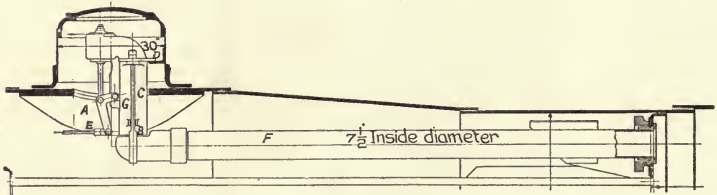

FIG. 61.—American throttle valve.

traveller as the regulator, a handle on the back plate of the fire-box, which seems to possess a magic power of calling the enormous machine into life. It derives its name from its function, which is to open or shut a valve inside the boiler, which controls and regulates the supply of steam to the cylinders. When the boiler is fitted with a dome of any kind, this valve is always placed within it. When there is no dome the valve is placed, as a rule, in the smoke-box. If not, then just inside the front tube plate.

The valves are of two kinds. They are either double-beat valves, or sliding valves. The first type is almost invariably used in the United States. Figs. 61 and 62 give the general arrangement and a section to an enlarged scale of an American regulator valve. It will be seen that the valve is of the double-beat equilibrium type. It is entirely surrounded by steam,

which tends to force the upper valve down on its seat and lift the lower valve off it. A bell-crank lever A is arranged in such a way that by pulling on the lower extremity E the valve is raised from its seat, and steam is admitted to the cylinders. A rod E extends from the bell-crank lever to the back plate of the fire-box, where it traverses a stuffing box, and is jointed to a transverse lever which is moved by the engineman pushing it in to shut off steam; pulling it out turns steam on.

The "dry pipe," that is, the steam pipe inside the boiler, is shown at F; the whole valve box is supported inside the dome on the angle-iron ring B, Fig. 62, by a flange D, Fig. 61. At B is a conical ground joint fitting a seat in a flattened portion of F. The surfaces are drawn together steam tight by the bolt C. The fulcrum of the bell crank is at G.

The valves are not perfectly balanced, because in the first place it is desirable that there should be a tendency to keep the valve closed, and in the second, the lower valve has to be passed through the seating of the upper valve to get it into place. In the valve illustrated, the upper valve is 6 inches diameter and the lower valve $5\frac{3}{8}$ inches. The area of the upper valve is 28.27 square inches, that of the bottom valve 22.7 square inches. With a boiler pressure of 200 lbs. the top valve is held down with a force of about 5,654 lbs., or over 2.5 tons. The lower valve, however, tends to lift off its seat with a force of 4,540 lbs. The difference is 1,114 lbs., and at first sight it would appear that the engine driver would have to pull very hard indeed to get the valve off its seat. But this is not so. In the first place he has considerable leverage to help him and the moment the valve is opened a hair's breadth the valve is in equilibrium. In the

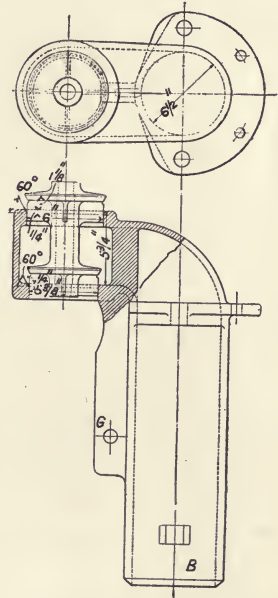

FIG. 62.—Throttle valve.

second place, the rod, where it passes through the stuffing box before referred to, is more than an inch diameter. If it has a square inch of sectional area then the steam pressure inside the boiler will tend to push the rod out, so assisting the driver with an effort of 200 lbs. By making the rod still larger we can go on restoring, so to speak, equilibrium. But it must be kept in mind that the resistance to opening the valve only exists so long as it is shut; as soon as it is opened at all the pressure inside and outside the valve box becomes nearly the same. The thrust on the rod is then unbalanced, and the valve as soon as opened a little would be forcibly lifted as far as it would go. To prevent this the lever on the back of the fire-box works in an arc, known in the United States as a "gate"; this is provided with notches into which drops a detent working on the edge of the regulator lever. In this way, the valve may be set open much or little. Sometimes the lever is fitted with a fly nut, by which it may be secured in any position.

In some cases the bell crank is so set that the regulator handle has a very greatly augmented leverage at first, so that the valve can be opened by a small effort just enough to admit steam to the engine and so establish equilibrium.

In this country the double-beat valve is little used, the sliding valve being preferred. The main steam pipe is fitted with an elbow rising into the dome. The mouth of the pipe is stopped by a vertical plate, in which are two or more rectangular holes or ports; on this plate slides another with similar holes. When the holes coincide, steam is admitted to the cylinders. The plate can be moved up and down in either of two ways. According to the first, a bell crank and rod are fitted precisely as just described. The horizontal limb of the bell crank then moves the sliding plate up and down. More usually a "winch" handle is used, and an arm on the long spindle is jointed just under the dome to the valve. A partial revolution of the regulator handle then suffices to put on or shut off steam in a way with which every one who has seen a locomotive started is familiar. In all this there is little room for variety. One improvement may be mentioned in the valve. It consists in placing a subsidiary

sliding plate on the back of the principal valve, which plate has a small hole in it. When steam is shut off, there is, of course, a heavy pressure on the back of the sliding valve which makes it hard to open the regulator. Now the first effect of moving the regulator handle is to act on the subsidiary valve, which offers little resistance. This admits steam at once to the main steam pipe between the cylinders and the regulator. This equalises the pressure on both sides of the larger plate, which can then move quite freely. On the London and South Western Railway, Mr. Drummond has entirely done away with the stuffing box. A collar on the regulator spindle has a face ground to fit the inner end of the brass casting through which the spindle passes. The pressure of the steam thrusts the collar against the casting, making a steam-tight joint.

Safety valves are important, although good firemen seldom give them much work to do. They do not require minute

description. The first safety valves were always loaded directly by a lever of the second order. They were, as they are still, conical brass or gunmetal valves resting on seats of the same metal. They constituted ornamental features, being carried on fluted columns, standing a couple of feet above the top of the boiler. The loading was always effected by a spring balance as shown in Fig. 63, and the area of the valve, the length of the lever, and the graduation of the spring balance index were so adjusted to each other that the figures on the index plate B showed the pressure when the valve blew off. Now, the index hand was carried by a stout stud, and it was quite possible by turning the adjusting nut by which the pressure at which the valve lifted was regulated, to set the stud hard against the top of the slot in which it moved. Then the valve could not lift at all. Engine drivers with trains a little too heavy were in the habit of so setting safety valves fast in order to get more pressure. Even when an explosion did not follow, the boilers were strained and the tubes caused to leak. Ferrules, as at A in dotted lines, were then fitted on the screws

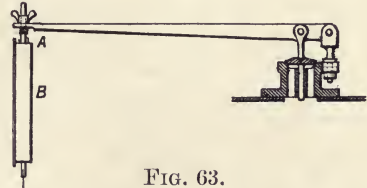

FIG. 63.

of the spring balances, so that they could no longer have the indexes set up against the tops of the slots. Then the engine-men loaded the lever direct with anything, such as a couple of links of wagon chain. To meet this, Mr. Ramsbottom, when Locomotive Superintendent of the London and North Western Railway many years ago, invented a most ingenious valve, which is largely used now, and was used to the almost total exclusion of all other valves up to a recent period. It is illustrated in Fig. 64. Two valves of precisely the same size are placed side by side on top of short pillars; between them is a stout coiled spring, one end of which is hooked into an eye between the two pillars, and the other into a hole in the middle of a lever. Projections or horns on the lever bear on the centres of the two conical valves. It will be understood in a moment that the one spring loads both the valves, and must be twice as strong as if it loaded only one. A diameter of a little over three inches, with an area of ten inches, is a very common size for a safety valve.

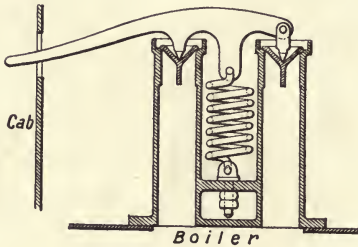

FIG. 64.

If the pressure is 150 lbs. then each valve must be held down under a force of $150 \times 10 = 1,500$ lbs. or for the two valves, 3,000 lbs., and the spring must be strong enough to apply this pressure. The end of the lever is prolonged into the cab, and the driver can always be certain that a valve is not sticking, because by pulling down the end of the lever he takes all the load off the valve furthest from him, and by lifting it up all the load off the valve next to him.

At first sight it would appear that this valve could not be overloaded, as the load was settled for good in the workshops by adjusting the lengths of the horns on the lever. But, even so, the engine-men were not beaten. They overloaded the valves by putting shot into the excavation in the tops of the valves. When there was no steam in the boiler, by pulling down the lever they lifted the horn on the outer valve and the shot ran in under

it. The same process produced a like result with the other valve. The effect was the same as lengthening the horns; the tension of the spring was increased, and in this way 10 lbs. or 20 lbs. were added to the pressure. All loose shot was carefully removed, and until the valves came to be specially examined the fraud was never detected. Mr. Webb, Mr. Ramsbottom's successor, then fitted the valves with a casing so constructed that shot could not be put into the valves, and he offered a reward of £5 to any man who could overload the valves; the money was never claimed.

Within the last few years it has been deemed desirable to fit more than two safety valves to the very large boilers now in use, and something more compact than the Ramsbottom valve became desirable. Therefore, we now find three or even four valves loaded direct, each by a coiled spring, and grouped in one casing. No easing gear is needed, because the valves are constantly under observation, and it is almost impossible that they should all stick. On some lines "Pop" valves have been tried. They are so called, because instead of rising gradually as the pressure increases after they have begun to blow off, they lift suddenly with a "pop" and blow off hard for a minute or so until they have reduced the pressure about 3 lbs., then they shut suddenly until the pressure again rises, and so on. This intermittent action is very noisy and objectionable in railway stations. It alarms passengers, and does no good, so pop valves have never found much favour with locomotive superintendents. The pop action is got by so shaping the valve and valve seat that the area on which the steam can act is augmented by the rising of the valve.

It is essential that the precise level at which the water stands in the boiler should be known. In old times—and indeed, to this day in America—three "pet" cocks, or "try" cocks, were screwed into the back of the fire-box about 3 inches above each other. If when the lower one was opened steam came out, then the water was too low. If when the top one was tried water came out, it was too high; when it was just right, steam came out of the top cock, water and steam out of the middle cock, and water alone

out of the lower cock. The indications thus supplied were not easy to read, because the hot water flashed into steam at once. The whole system was dirty and inefficient, and has long since been superseded by the glass water gauge, which is too familiar to require illustrations. The tube is made of a very special hard glass with a minimum of alkali in it, which will not dissolve under the high pressure to which it is exposed. Soft glass in high pressure steam will become cloudy and corroded in a few hours. The glass tube is passed through a stuffing box at each end, in which it is packed by india-rubber rings, which permit free movement. Any attempt to confine the tube is certain to result in breakage. It is usually about half-an-inch bore. Since very high pressures have been introduced, it is usual to box the gauge up in a shield made of pieces of thick plate glass, because a broken gauge tube is apt to fly and wound the driver or fireman. In some cases gauges are fitted with ball valves at the top and bottom, which remain at rest in little pockets unless the glass gives way. Then the violent rush of steam above and water below lifts the balls, and blowing them on to seats, the steam and water are automatically shut off. When the driver shuts the stop cocks the automatic valves fall away again to their normal position.

We have now got the boiler complete, with all the appurtenances which concern the outflow of steam from it except the whistle, which does not require description; and we have, lastly, to consider the means by which water is put into it.

CHAPTER XXV

THE INJECTOR

A LOCOMOTIVE will evaporate, according to its size and its load, from three to seven tons of water per hour, and as this has to be forced into the boiler with certainty and regularity just as it is wanted, it will be seen that the efficiency of the feeding apparatus is of the last importance. For many years the water was invariably pumped in. Two horizontal plunger force pumps were fixed inside the frames, one at each side, the plungers being moved by the cross heads on the piston rods. Now and then short-stroke pumps, worked off the crank shaft by eccentrics, were used. The steam locomotives on the Metropolitan and District Railways were thus fed. No recently built engines, however, are fitted with feed pumps save under special circumstances, and it is unnecessary to say more about them than that they presented no particular features of any kind calling for description. The system was inconvenient because no water could be put into the boiler while the engine was standing. It was not at all unusual to have to uncouple a locomotive from its train, and run it up and down the line for half a mile, both pumps going for all they were worth, until the boiler was replenished, and then couple it up again to its train. A simpler plan was to jam the brakes hard on the tender wheels, then to oil the rails and the rims of the driving wheels, which of course were not coupled, and then to turn on steam and let the driving wheels revolve, both pumps being at work. When the boiler was satisfied the brakes were taken off, and a couple of shovelful of sand on the rails enabled the engine to move ahead. Later, engines were often fitted with small donkey feed pumps.

Locomotive boilers in the present day are always fed by injectors. The injector is an instrument so remarkable and so

paradoxical in its action that it cannot be dismissed in a few words. It has been made the subject of much mathematical investigation, to which it lends itself so badly that no satisfactory theory has been established which will account for all the phenomena which it presents. Enough is however known to enable an entirely adequate explanation of its action to be given.

A comparatively small quantity of steam supplied by the boiler is passed through the injector and picks up cold water from the tender, heats it, and forces it into the boiler. The paradox is that steam of, say, 150 lbs. pressure should come out of the boiler, and then find its way in again, carrying the feed water with it, against the same 150 lbs. pressure. Here we apparently eat our cake and still have it. It is not remarkable that on its first introduction engineers refused to believe in it. Articles indeed were written to prove that all the laws of the conservation of energy would have to be remodelled if the injector really worked, and much more to the same effect. The injector works, however, and no one now thinks that it upsets any law. On the contrary, it is a beautiful embodiment of laws lying at the root of all thermodynamical facts.

How the injector came into existence is not accurately known. It originated with M. Henri Giffard, a French engineer, in 1858. So far as available information goes it was a discovery, not an invention. He brought it over to this country, and Messrs. Sharp, Stewart & Company, very eminent locomotive engine builders of Manchester, acquired the sole rights, and for many years constantly effected improvements. The expiration of the original patents threw the injector open to the world. Several firms took up its manufacture, and it is to-day a very different instrument from what it was originally. The first locomotive in this country to be fitted with an injector was the "Problem," an engine with outside cylinders and a single pair of driving wheels, 7 feet 6 inches in diameter. Sixty of these engines were built by Mr. Ramsbottom at Crewe for the Northern (Holyhead and Crewe) section of the London and North Western Railway in 1862.

When a jet of steam is permitted to strike against an obstacle

it loses its velocity, and its momentum reappears as pressure. It is only necessary to hold a board in front of a jet of steam to prove this.¹

Let us suppose that a bullet-proof plate is supported by a spring at the back, and that a rifle is fired at it. The plate will be driven back and move forward again every time it is struck.

Let us now further suppose that instead of a single rifle the plate is fired at by small machine guns; the bullets will now impinge on the plate so rapidly that it will not move forward at all. The spring will be kept permanently compressed, and we shall have to all intents and purposes the momenta of the bullets converted into pressure. Now the molecules of steam, however small they are, possess momentum, and so, as has been said, they, acting as so many tiny bullets, produce pressure on any surface against which they strike.

The force with which each bullet strikes is expressed by the equation $E = \frac{M V^2}{64 \cdot 4}$ where E is the stored-up energy in the bullet, M its mass and V^2 the square of its velocity. The meaning of this is that if a bullet had a velocity of 1,000 feet per second, and weighed one-tenth of a pound, then at the moment of striking it represented energy sufficient to lift 1,537 lbs. a foot high, or 18,444 lbs. one inch high, or 184,440 lbs. one-tenth of an inch, and so on. The fact with which we have to deal is that energy augments, not as the velocity, but as the square of the velocity. Next let us suppose that two bullets of equal weight moving at the same velocity in opposite directions encounter each other. It is clear that they would be flattened or shattered. Neither would give way and retire before the other. If, however, one of the bullets moved faster than the other, then the slower bullet would be overcome, and we may then suppose the two bullets

¹ The accepted theory explaining why gases exert pressure on the inside of the vessel containing them is that the molecules of which the gas consists are in extremely rapid motion, continually striking against and rebounding from the wall, just as a billiard ball rebounds from the cushions. The number is so enormous that individual impacts cannot be distinguished, and the average effect is to produce pressure.

moving together at a less speed than either possessed before, in the direction of the flight of the bullet with the greatest velocity.

To put this in another way, let us suppose that a jet of steam is suddenly turned into a swarm of hailstones. If the steam was moving at, say, 3,000 feet per second, it is clear that the hail would continue to move at just the same velocity.¹ In the same way, if the steam were turned into water, the velocity of the water would be that of the steam, and if the water was turned into another body of water it is clear once more that it would set up a violent current in that water.

So far nothing has been said about getting water into the boiler. Let us suppose, however, that our jet of steam, on its way to the nozzle through which it flows, comes in contact with cold water. The result will be that it will be condensed, but, as has just been shown, it will not thereby cease its onward flight. It will transfer its momentum to some of the cold water, which will then join the condensed steam, and by dint of sheer momentum the two will force their way into the boiler. The steam will play the part of gunpowder, and the water will act as a bullet, producing, as we have explained for machine-gun bullets, a pressure which suffices to overcome the resistance offered by the water under pressure in the boiler, and so the boiler is supplied, and water thus propelled will enter a steam space just as freely as it will a water space. All this is so far sufficiently simple and obvious; but the discovery of a principle and the putting of that principle into practice are two very different things.

The first injectors made were very uncertain in their action, very large, and required many adjustments to induce them to start and to keep them going. These troubles have been got over in large part by the introduction of what is known as the diverging nozzle, and in part by the use of very simple and yet

¹ This is not strictly correct because of the reduction in volume, but the inaccuracy is of no consequence here. The reader is referred to any good text book of physics for the mathematics of the flow of gases and liquids under varying conditions.

very efficient automatic self-adjusting devices which do what the fireman had to do at first but very much better. The theory of the diverging nozzle is set forth with much prominence in most treatises on hydraulics and all treatises on steam turbines, to which the reader who desires further information is referred. For our present purpose, it is enough to say that it gives a more powerful and compact jet than can be had without it. The accompanying engraving, Fig. 65, shows an injector as used on locomotives thirty years ago, and one quite efficient and able to work. The steam enters at A and passes through the diverging

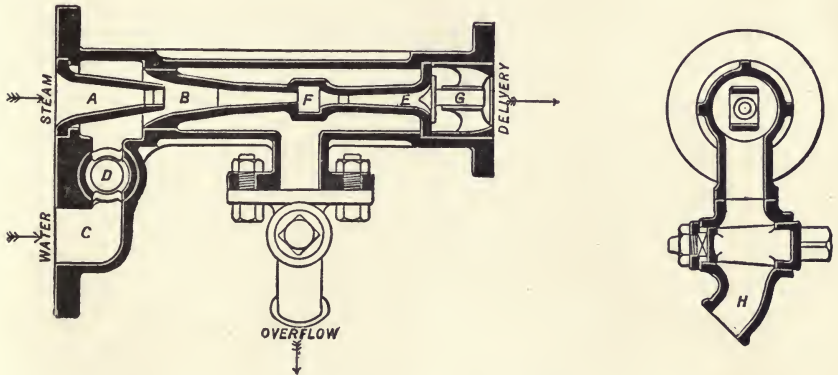

FIG. 65.—Section of injector.

cone B. Through C cold water from the tender enters. D is a cock for regulating the supply. In dealing with draught it has been shown that the exhaust steam draws the products of combustion with it and sends them up the chimney. Now in just the same way the steam leaving A draws in water, is condensed, and drives it forward through the second nozzle, which is contracted because the steam being rapidly condensed the volume to be passed through E is much diminished. The condensed steam and feed water leap across the gap F' and enter the cone E, which it will be seen is an expanding nozzle at the end of which is a check valve G, intended to prevent the return of water from the boiler when the injector is stopped. E is expanded in order

that the velocity of the steam may be reduced and its "energy of translation" converted into pressure. B and E are united by two bridges in a way that will be understood from the cross section of the overflow cock H.

It may be asked, Why not make the two cones B and E continuous? The answer is that the injector will not always start. The water is indeed driven into E, but not with force enough to get into the boiler. Usually this is because too much water gets in at C and drowns the instrument. To provide for this, the overflow cock H is fitted, through which the surplus water escapes until the supply of water has been exactly adjusted to the steam. It may be that only the proper quantity of water goes in, but there is too much or too little steam. When all the proper adjustments are made, the injector sings, and the only loss of water is represented by a few drops which escape now and then at H.

The injector illustrated will not lift cold water, because it cannot make a sufficient vacuum in C. The difficulty is got over by the simple expedient of reducing the diameter of the steam nozzle, so that it is smaller than the discharge cone E. This was formerly effected by putting a conical spindle into A. Once the injector was started, the cone was gradually withdrawn to permit the entrance of sufficient steam.

A defect in all the earlier forms of injectors was that they were liable to be thrown off by jerks, which caused the water to surge in the tender, or in the feed pipes or boiler. When this happened, the fireman had to make all the adjustments over again, which was not an easy task on a jumping footplate. Accordingly various inventors sought a remedy, and now all injectors on locomotives are of the self-starting self-adjusting type. The modern injector is not very much larger than a champagne magnum, and requires no attention of any kind. To start it, the fireman has only two handles to turn, one on the tender which lets water into the injector, and the other on the back of the fire-box, which admits steam. Two injectors are always fitted. It is a usual though not an invariable practice to make one of these very nearly but not quite sufficient to keep the boiler

supplied. At the beginning of a run it is started, and is not meddled with while the train is running. The rest of the feed is put in by the other injector, which is used or disused by the fireman according to the rate at which evaporation goes on in the boiler.

It may be asked what effect the temperature of the feed water has on the instrument. The answer is that unless it is cold enough to condense the steam, the injector will not work. The critical temperature for ordinary injectors is about 120° F. At this temperature the quantity of water injected is about 20 per cent. less than at 50° F. The higher the boiler pressure, the colder must be the feed water. As to the actual amounts fed, the makers of injectors guarantee those set forth in the following table :—

Boiler Pressure.	lbs. of Water delivered per lb. of Steam.
60 lbs.	19
90 „	16
120 „	14
200 „	10

It is not necessary to describe in detail the construction of a number of the injectors used on locomotives. There are a great many by different makers. Sufficient has been said to give the reader an adequate idea of the theory of this very curious instrument, a theory, it may be added, which is neither so complete nor so sound as is desirable. All that the injector has to do is to overcome the static head of the water or of the steam which is measured by the pressure on the boiler side of the check valve. In effect there is a close analogy between the hydraulic ram and the injector. The necessary momentum being obtained not from gravity but from the impulse supplied by the steam.

Any account of the injector would be incomplete unless it took account of the recent modifications which have made the instrument self-starting. One example, an injector made recently

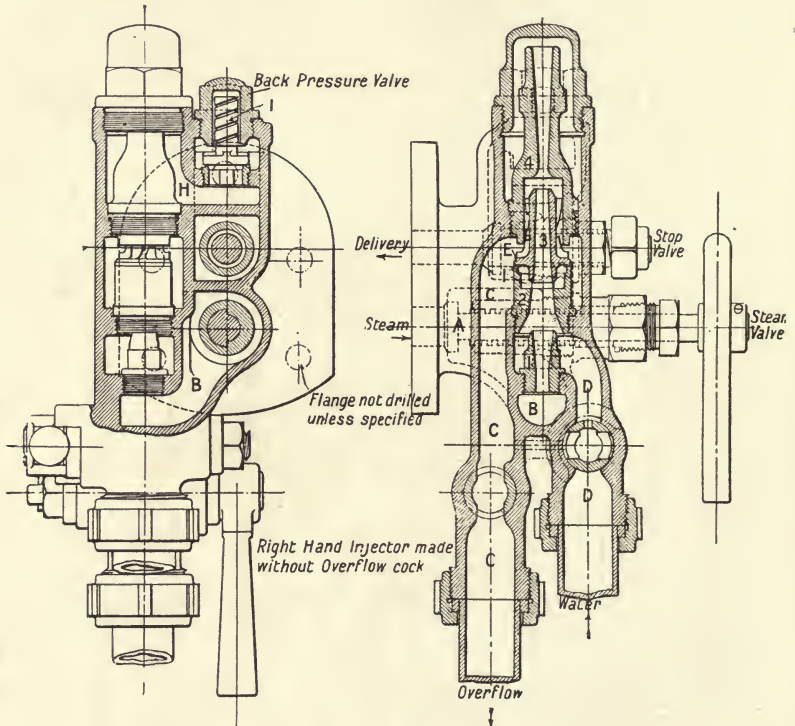

FIG. 66.—Self-starting injector.

for locomotives by Messrs. Gresham & Craven of Manchester, is illustrated by Fig. 66.

Let it be remembered that the action of an injector depends upon the fact that the velocity of a jet of steam discharging into the combining tube is twenty to twenty-five times that of a jet of water issuing from a boiler under the same pressure, and that the enormous reduction of the volume of the steam, during

condensation by the water, concentrates the momentum of the jet upon the area of the delivery tube, which is but a small fractional part of the orifice from which it issues, leaving a large margin of available energy.

This action has been ingeniously likened to a pump with a continuous piston equal to the area of the steam nozzle forcing a continuous ram equal to the lesser area of the delivery throat, the ram in this case being a small bar of "solid" water.¹

The cones in the Gresham injector are made in four parts, viz. :—No. 1, Steam Cone ; No. 2, Lifting Cone ; No. 3, Combining Cone ; No. 4, Delivery Cone.

An internal steam pipe from the dome of the locomotive conveys steam to the injector steam valve A, which upon being opened admits steam to the steam nozzle 1 by the passage B. The steam issuing from the steam nozzle lifts the base of the combining cone 3, which is free to slide in its guide, off its seat, and passes out freely through this opening to the overflow passage C, and on to the pipe of the injector. In so doing, it creates a partial vacuum in the water pipe D, and the water rises to the injector. The water coming in contact with the steam, travels with it through the lifting cone 2, and gradually condenses it.

The velocity of the steam being now, as previously explained, largely transferred to the water, the latter passes from the lifting cone 2, and through the combining cone 3 (which is now drawn back on to its face at E, owing to the high vacuum created in the chamber F by the passage of the jet), and these two cones, 2 and 3, become one combining cone, *i.e.*, the cone in which the steam and water combine. After passing through this combining cone the jet flows out at the overflow space G and down the passage and overflow pipe C until such time as it attains sufficient velocity to carry itself past this space and

¹ The word "solid" is not out of place. Dr. Le Bon, the great French physicist, cites the case of a jet of water used to drive a Pelton wheel. The head is 1,600 feet. The jet is 1 inch in diameter. It is absolutely impossible for the strongest man to cut through this jet with a sword, but the sword can be broken in the attempt.

enter the delivery cone 4. When it reaches this point its velocity is so great that it is sufficiently powerful to pass by the passage H, and lift the back pressure valve 1, and so enter the boiler.

The boilers of locomotives are invariably carefully clothed or "lagged" for three reasons. First to prevent the radiation of heat, secondly for protection from the weather, and lastly for the sake of appearance. The earliest engines were "rattle-boarded," the lagging consisted of narrow strips of wood beaded, and tongued with hoop iron, secured round the boiler with hoops, very often of brass kept polished. The fire-boxes of Bury's engines, which were semicircular in plan, were carried up in the shape of domes to give steam room, and covered with copper. Hence the name of "copper nob" which they obtained in the north. In France, while the boards were retained, they were covered with thin sheet iron, and in some cases in passenger engines with brass sheets, which were kept bright. This was all very well while coke was the fuel, when coal came in brass went out. Subsequently felt was interposed between the boards and the boiler, and the whole covered with Russia iron. When pressure rose the system would not answer, the felt was scorched and the boards caught fire. In the present day the lagging generally consists of some preparation of asbestos, often put on in the form of mattresses, and covered outside with sheet-steel plates. Abroad these plates are often left without paint, their natural oxide coating serving with the aid of a little oil to prevent rust. In this country they are always heavily painted and varnished, each railway having its distinguishing colours. The cost of painting and varnishing is a heavy item. It has been stated that Mr. Samuel Johnson saved the Midland Company several thousand pounds a year by substituting red oxide of iron for more expensive pigments. This is the reason why Midland engines are dull red. Mr. Webb used black on the London and North Western, relieved in the case of passenger trains by lining. The goods and coal engines he kept all black, and they were called by the profane "Webb's flying hearses."

The loss by radiation from an unclothed boiler is considerable

and with efficient lagging not great. Professor Goss gives the following table:—

Power lost by Radiation.				Horse power.	
Bare boiler at rest	12
„ „ running at 28 miles an hour	25
Covered boiler at rest	4·5
„ „ running at 28 miles an hour	9·3

Much depends on the external temperature. The maximum possible loss for an unlagged boiler seems to be about 10 per cent., and for a clothed boiler 4 per cent.

SECTION III.

THE LOCOMOTIVE AS A STEAM ENGINE

CHAPTER XXVI

CYLINDERS AND VALVES

IN all that concerns the work done by the engines of a locomotive they may be treated precisely as though they were stationary engines on land. By "work done" must be understood the development of power. The effect produced on the locomotive as a vehicle has already been mentioned; it will be dealt with again further on. The thermodynamic laws; the heat exchanges; the effects of expansion, compression and wire drawing, are just the same for the engines of a locomotive that they are for a stationary or marine engine working without a condenser. The engines do not know that they are travelling through space at high velocities, instead of working on fixed frame plates in a factory. The principal difference, indeed, between them and stationary engines is that the latter as a rule can run in only one direction, while the engines of a locomotive must be capable of turning round equally well in either direction. In this respect they resemble a marine engine; the fact complicates the valve gear, as will be explained further on.

Locomotives are always propelled by the action of steam pressing on pistons reciprocating in cylinders, which pistons cause the revolution of an axle by means of cranks and connecting rods. There are no locomotives in existence propelled by rotary engines or turbines. Up to a comparatively recent period

locomotives were divided into two classes only—inside and outside cylinder. Subdivisions are now necessary, because locomotives are made with both in combination. In this country although outside cylinders are freely used, inside cylinders have always been preferred. In the United States on the contrary the outside cylinder has been so favoured that very few inside cylinder engines have been built.

Although in the present day the construction and mode of action of a simple steam engine are very generally understood, it is desirable to say a few words here for the benefit of the non-technical reader who desires to comprehend thoroughly what the locomotive engine is.

The simple steam engine consists of a cast iron cylinder, bored out smooth and truly circular inside, in which moves backward and forward a cast iron piston in the edge of which are turned grooves. In these are placed elastic rings of steel or brass, which press outward against the side of the cylinder and prevent the passage of steam. The steel rod which is secured to the piston by a collar and nut, goes through a hole in the cover at one end of the cylinder. It passes through a stuffing box, which is filled with packing, so that no steam can escape round the rod as it moves backwards and forwards. The outer end of the piston rod is fitted with a cross head, which travels in guides to compel the rod to move in a straight line. To the cross head is jointed one end of the connecting rod, the other end of which lays hold of the crank pin, and as the piston moves backwards and forwards the connecting rod alternately pulls and pushes the crank pin and makes it rotate. When the piston is at each end of its stroke the crank is on a "dead point," but the revolving momentum of the driving wheel carries the crank over the dead point, and keeps the engine going, and besides, there are always at least two engines acting on cranks at right angles to each other, so that when one is on the dead point the other is in full activity. In this way, the driving wheels are made to revolve, and propel the locomotive. Steam is brought to bear on opposite sides of the piston alternately in the following way:—In the cylinder at each end is

made a port, which by a curved passage communicates with the valve chest. In this are two ports, one for each end of the cylinder, and between them a third port which communicates as directly as possible with the blast pipe already described. The ports are opened and closed by the slide valve, which is in effect a shallow box with very thick ends and sides. The cast iron face in the valve chest in which are the ports is made quite flat and smooth, and on it rest the ends and sides, also flat and smooth, of the slide valve. The valve chest is full of steam which presses the valve down on the port face or seat. The exhaust port is always open to the slide valve inside. As that moves backwards and forwards it includes

first one cylinder port and the exhaust port, and then the other cylinder port and the exhaust port. When this last happens the steam in the cylinder escapes through the box-slide valve and exhaust port up the chimney.

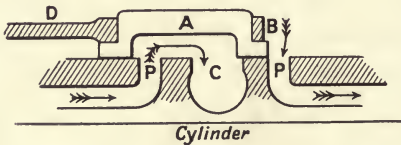

FIG. 67.

At the same time the slide valve opens the port at the other end of the cylinder, so that steam rushes in and fills the cylinder, and so on alternately for both ends, and the piston is moved backwards and forwards, the driving wheel revolves, and the exhaust steam escapes up the chimney and causes a draught in the fire-box.

The accompanying sketch, Fig. 67, will make what has just been said clear at a glance. A is the slide valve in section, B the bridle, a rectangular frame on the end of the valve spindle D dropped loosely over the valve, P P are the steam ports, and C the exhaust port.

The first locomotive had only two simple cylinders. In the present day we find engines with two, three, and four cylinders arranged in different ways. However by far the larger number of locomotives in this country have two cylinders only, fixed between the frames. In the United States always, and in other countries almost always, locomotives have outside cylinders.

On the whole, for very good reasons, the inside cylinder is to be preferred. The favour shown to outside cylinders is due partly to caprice, in part to certain national conditions. Thus it is beyond doubt that French engineers, and, indeed, continental engineers, generally, "like to see the works." They claim that all the parts of an outside cylinder engine are more under observation, and can be more readily cleaned and examined, and kept in repair than those of an inside cylinder locomotive. In Europe and America "pits" are unusual. That is to say, the excavations between the rails over which a locomotive can stand and in which men can work erect on the machinery. Again, a cranked axle is not required, and greater length of bearings can be had. In Europe there are scarcely any passenger platforms, and engines can be made much wider than in this country, which means that there is plenty of space available for outside cylinders. Here cylinders up to 19 inches in diameter have been used outside, but the arrangement is more cramped than it is abroad. It is, of course, true that the platforms are not necessarily on a level with the cylinders. But it would not do to let the cylinders overhang the platform.

In the United States, the outside cylinder is peculiarly suited to the bar frame. In the same way the inside cylinder goes naturally with the plate frame. We shall deal with the inside cylinder engine first.

We have two flat frame plates, spaced about 4 feet 1 inch apart, between these must be fixed the cylinders. If these are 18 inches in diameter they will occupy, allowing 4 inches for the cylinder walls, 3 feet 4 inches, but ports cannot be worked in a thickness of 1 inch. Allowing 3 inches for each cylinder inside we have 3 feet 8 inches, which leaves only 5 inches for two slide valves, if they are placed vertically between the cylinders. This is cutting things so fine that, although 18 inch cylinders with the valve chest between them have been used, it may be taken that 17 inches is the largest diameter which can be adopted. When greater dimensions are necessary, the valve chests are placed on the tops of the cylinders, or right underneath them.

On the Western Railway of France locomotives were at one time running with the cylinders inside. The valve chests were outside and came through rectangular apertures cut in the plate frames. The whole of the valve gear was outside, although a crank shaft of the normal kind was used. In the United States slide-valve chests are invariably on top of the cylinders, the slide valves being actuated by rocking shafts. In this country top valve chests are usually so inclined that the valve spindles point directly to the centre of the diameter of the crank shaft.

Formerly, the cylinders were always cast separately, each with its valve chest, and each was made with a heavy flange on the outside to take the side frame, and on the inside to match the other cylinder. These flanges were all planed and faced up dead true. The two inside flanges were placed in apposition, and secured to each other by a number of $1\frac{1}{4}$ inch bolts turned truly cylindrical, and so tight a fit in carefully drilled holes in the flanges that they had to be driven home with a heavy hammer. The two

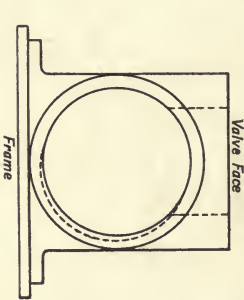

FIG. 68.

cylinders thus became ostensibly one. In the same way the two outside flanges were bolted one to each side frame. Excellent as this arrangement is, however, it was found that in practice the cylinders tended to work loose from each other, and from the side frames, and in the present day the cylinders are almost always cast together in one piece. The foundry work is a little more expensive and there is more risk of making "wasters," but the result is much more satisfactory.

Cylinders are always cast of a special mixture the precise nature of which is usually kept as a secret in every foundry. The object is to get a tough cast iron which will not crack, and yet will be just as hard as will only permit it to be bored with some difficulty. Cylinders wear oval, but curiously enough, not on the bottom, as might be imagined, because it has to carry

the weight of the piston, but at an angle such as shown by the dotted line in the accompanying sketch, Fig. 68.

While the front ends of the cylinders are open for their full diameter in order that the pistons may be put in, the back ends are made with openings of not more than half the diameter, which are closed by permanent lids, which are cast in one with the stuffing boxes. The opening at the back end is provided because it facilitates moulding in the foundry, and through the opening is passed the bar which in the boring machine carries the cutter head, in the edge of which are the steel boring tools. The modern boring machine is invariably double. It has two horizontal boring bars accurately parallel, and both cylinders are bored at the same time. The boring bars rotate at such a velocity that the speed of the boring tool is about 20 to 30 feet per minute, depending on the hardness of the cylinder. The harder it is the slower the cut. Two cuts usually suffice, one a roughing cut and the other a smoothing cut. The front cylinder cover is usually cast convex, and with ribs to give it strength. It may have to support a load of 20 to 30 tons. Its flanges are carefully faced and scraped up, as are the flanges of the cylinder, and a steam-tight joint is secured by screwing up the nuts, which work on studs screwed into the cylinder flange, sometimes a little very thin red lead and oil are smeared on the metal faces, and when the cylinders are old and the lids have been taken off and put on several times, it may be necessary to interpose a ring of thin brown paper which has been soaked in boiled linseed oil, in order to make the joint tight. To reduce clearance the piston is cupped to fit the convexity of the cylinder cover.

Formerly the stuffing box in the back cover was packed with hemp soaked in tallow. In the present day, it is almost always packed with white metal rings. White metal is an alloy of tin, lead and antimony. A great number of patents have been taken out for metallic packing. This packing consists of a number of coned segments which are put into the stuffing box and surround the rod. As the "gland" is screwed down it will be seen that the cones act to force the packings against the rod on the one

hand and the sides of the stuffing box on the other. In some cases, a coiled spring is used to press the segments together. When the lubrication is attended to properly, packing of this kind gives no trouble and remains quite tight for several months.

As the connecting rod works at various angles throughout each revolution, the piston rod must be guided. The accompanying sketch, Fig. 69, explains why. When the crank A is vertically up the connecting rod is pulling, as shown by the arrow. If the length of the rod be taken as the pull then that pull is represented by two forces; the one measured by the length of the crank tending to pull the crank down in the direction of the arrow, the other precisely equal in amount

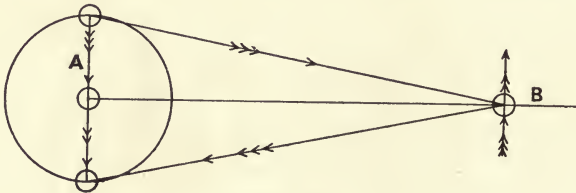

FIG. 69.

at the other end of the connecting rod tending to lift the cross head and piston rod up. If the pull on the cross head was 25,000 lbs., and the connecting rod five cranks long, then the pull tending to rotate the crank would be 20,000 lbs., and to push the crank down 5,000 lbs., and to lift the cross head up 5,000 lbs. In the same way, when the crank was vertically downwards the connecting rod would now push as denoted by the arrow, and tend still to force the crank down and the cross head up with a force of 5,000 lbs. It will be seen that the guides must withstand very heavy vertical stresses.

There are three systems of guiding cross heads in use. According to the first form, rectangular steel bars are placed in pairs, one pair at each side of the piston rod. Two long cast iron blocks slide between these bars. A pin passes through both blocks and the cross head between them, and on the pin

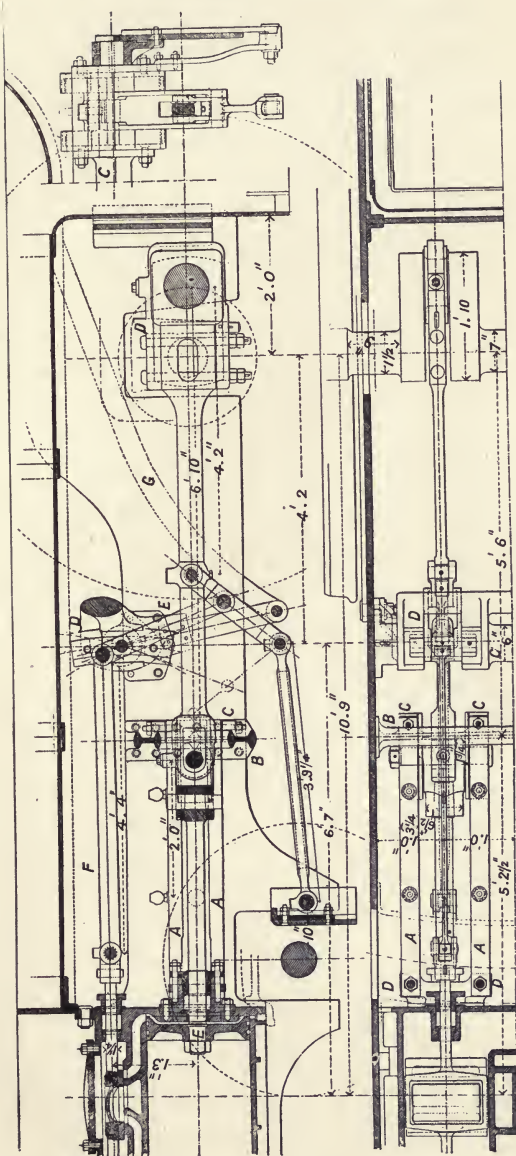

Fig. 70.—Joy's valve gear.



works the small end of the connecting rod. The arrangement is illustrated in Fig. 70, which shows a very excellent engine with Joy's valve gear, designed several years ago for the Great Eastern Railway by Mr. James Worsdell. AA are the guide bars. Across the engine, about 3 feet further back than the ends of the cylinders, a "motion plate" BB is bolted between the frames. This is always, in the present day, a steel casting shaped to be as strong and yet as light as possible. In the casting are four openings, through two of which the connecting rods pass, through two the valve-gear rods.

On the face of the motion plate are provided four "snugs," through each of which is a hole. The stuffing box is also provided with snugs DD, and to these the slide bars are secured by a bolt and nut at each end. Between the bars and the snugs are placed copper plates. When the engine is being erected these plates can be reduced in thickness by filing, so that the distance between the slide bars can be regulated with the most minute accuracy. This form of guide, with certain improvements and modifications, is still very popular for inside cylinder engines with which alone we are now dealing.

The second arrangement is simply a variant of that just described; only two guide bars are used. These, instead of being at the sides, so to speak, of the piston rod are fixed one over, the other under it, sufficiently far apart to clear the connecting rod as it rises and falls. The cross head is grooved on the edges to fit the slide bars. At one time this arrangement was very much used for outside cylinder engines, to which it is well adapted.

The third and last system is a modification of a marine engine guide, the "slipper" guide. It has long been a favourite with Mr. Drummond, of the London and South Western Railway, and Mr. James Holden, Chief Mechanical Engineer of the Great Eastern Railway, used it almost to the exclusion of all other systems. Fig. 71 is a longitudinal section of a cylinder with the piston, cross head and connecting rod as fitted on the Great Eastern Railway; it will be seen that only a single heavy bar guide is employed. This is fixed above the piston rod, and on it slides the "slipper," really a species of box; B is the motion plate.

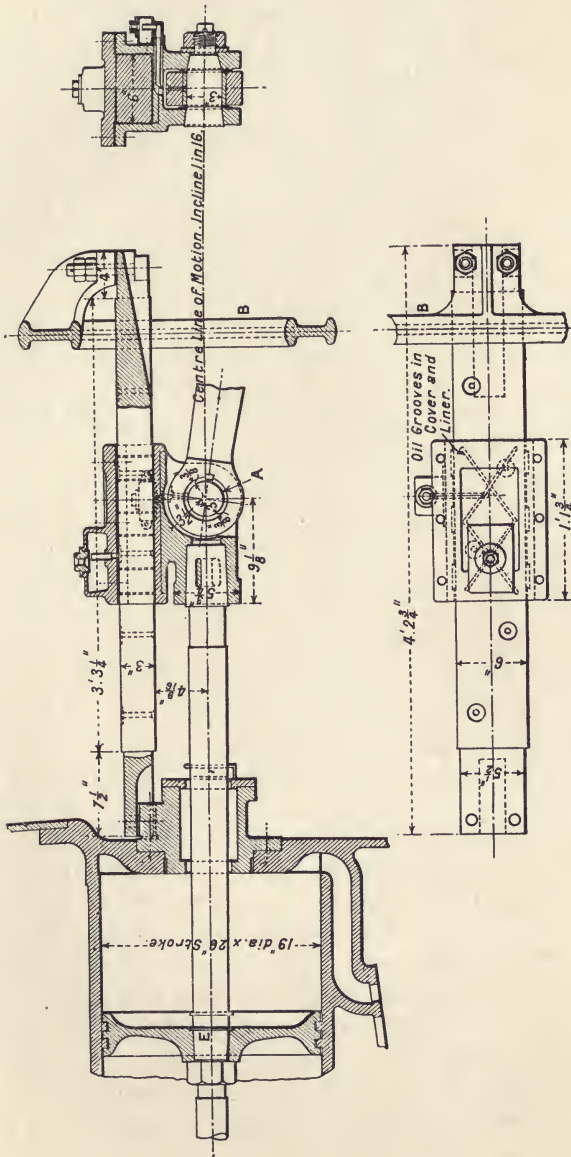

FIG. 71.—Cross head, Great Eastern Railway.

When the engine runs chimney first the thrust due to the obliquity of the connecting rod is always, as we have seen, upwards and is taken by the solid part of the slipper. When the engine runs backwards the flat plate bolted on the top takes the stress. The whole arrangement is cheap, easily fitted up with great accuracy, and easily lubricated. The rubbing surfaces are very large, and the results had with it are so satisfactory that all the engines on the Great Eastern Railway are made with it. In the larger engines the piston rod is prolonged as shown and passed through a stuffing box in the leading cylinder cover. This takes some of the weight off the bottom of the cylinder. It may be added here that when superheated steam is used the rod must be carried through the front cover and provided with a guide to prevent the piston cutting the cylinder.

The small end of the connecting rod lays hold of the cross head pin, which is of steel hardened on the outside. Many years ago the late Mr. Francis Webb, of the London and North Western Railway, seeing that the amount of movement round the pin made by the bearing on the connecting rod is quite small, did away with all power of adjustment, and forced into the end of the connecting rod a solid bush, which fits the pin accurately. This bush is shown at A in Fig. 71. The wear is extremely small. When the bush has become too slack on the pin, wearing oval and beginning to knock, it is forced out of the rod by hydraulic pressure and replaced by a new bush. Previously, connecting rods were fitted at both ends alike with brasses which could be closed up on the pin by a tapered wedge, known as a cotter, D, Fig. 70. This was far more expensive and liable to get out of order than the bush, but it is still in use on some lines. As for the "big end" of the connecting rod—that which grasps the crank pin—there are many patterns in use, but the principle is always the same. We have either the strap with a wedge cotter, or what is known as the marine big end, so called as it is almost invariably used in marine engines. Here the two brasses of the connecting rod are held together by a cap and two bolts with nuts.

CHAPTER XXVII

FRICTION

BEFORE proceeding further it is desirable to call attention to the question of friction. It is a very interesting fact that some of the loads carried by journals and brasses in locomotive engines are far heavier than can be regarded as safe in other machinery. That heating occurs so rarely is due to accurate workmanship, the use of white metal, efficient lubrication, and, above all, to the rush of the engine through the air, which carries off the heat. The bearings are in one sense too small for their loads, because the gauge—4 feet 8½ inches between the inner faces of the rails—is too narrow for the large engines now in use, although it answered very well on the Stockton and Darlington and Wylam colliery lines on which the first “Puffing Billy” ran. The diameter of a crank shaft and of the various journals on it may be increased, but its length is fixed by the distance between the inside faces of the main frame, which is precisely 4 ft. 1 in. The accompanying table gives the dimensions of a crank shaft suitable for an engine with 17 inch cylinders, 24 inch stroke, four coupled wheels 6 feet 7 inches in diameter, and 160 lbs. boiler pressure :—

CRANK AXLE.

	Ft.	ins.
Diameter at wheel seat	0	9
do. at bearings	0	7½
do. at centre	0	7
Distance between centre of bearings	3	10
Length of bearing	0	9
Diameter of crank pin	0	7½
Length of crank pin	0	4½

As has been said, with larger engines the diameters will be greater, and with smaller less. The figures given are, however, sufficient for our present purpose. The actual effective bearing surface of a railway axle journal may be taken at $\cdot 3$ of its total surface. Now, the total surface of a bearing $7\frac{1}{2}$ inches \times 9 inches is 212.4 inches, and three-tenths of this is in round numbers 64 inches. The load on each main bearing may be taken as 7 tons, or 15,680 lbs. and $\frac{15,680}{64} = 245$ lbs. per square inch, which is quite a moderate load.

The conditions, however, as regards the crank pins are quite different. Taking the average cylinder pressure as only, 75 lbs. we have for a 17 inch cylinder a pull and push on the crank pins of about 17,000 lbs., and 32.4 as the available bearing area in square inches. Now, $\frac{17,000}{32.4} = 521$ lbs. as the load, which is very heavy. When the engine is starting from a station or climbing a bank it may very easily reach twice this with a boiler pressure of 160 lbs.

It may be said, Why not make the crank pins longer? The position of the centre of the length of the crank pins is fixed by the distance between the centres of the cylinders, therefore the crank pins must be lengthened symmetrically, if at all. This means that either the main bearings must be shortened, or the crank webs reduced in thickness. Now, crank axles almost always break through the webs when they break at all, and for this reason when webs are rectangular or oval in shape they are always fitted with wrought iron or steel safety hoops shrunk on. Various expedients have, however, been tried to get over the difficulty. Mr. James Worsdell, when Locomotive Superintendent of the North Eastern Railway, made the crank webs circular discs. In this way we get plenty of metal at the weakest part of the web, and are enabled to thin it down, and so lengthen the crank pins. Abroad, a curious arrangement known as the half-crank has been used. The driving wheels are inside, not outside the frames, and the crank shaft does not pass through the wheel. The outer end of the crank pin is secured in the boss of the wheel,

and in this way some additional length is obtained, but it does not appear that the game is worth the candle.

The crank shaft of a locomotive is very expensive. It is forged out of solid steel, a roughly round bar with two lumps of metal on it. These lumps have gaps cut in them, either by slotting out the metal with a thin tool, or by a cold band saw. The crank pins and bearings are all subsequently finished in the lathe. In marine engines, for many years, the built-up crank shaft has been used with great success. The crank webs are separate pieces, as well as the crank pins and the plain portion of the axle; all the holes are drilled and the parts turned with minute accuracy, and the whole axle is then put together under hydraulic pressure. The result is a cheap crank shaft, thoroughly sound and good. Mr. D. Drummond has used this type of crank axle for some years on the London and South Western Railway. Built-up cranks are also coming into favour in America.

Pistons are usually made of tough cast iron, although steel is not infrequently employed, and in certain cases the piston and its rod are forged in one piece. The securing of a piston to the rod presents some difficulties; practice in the matter varies. As a rule a tapered hole is bored in a boss in the centre of the piston. The piston rod is coned at the end to fit the hole, into which it is drawn very tightly by a nut placed on the screwed end of the piston rod beyond the taper. Some designers turn a collar on the rod, as at E, Figs. 70 and 71, against which the piston is forced. Others only use a set-off at the base of the cone. If the cone is too tapered the piston may be split. The nut is always liable to work back; many engineers maintain that the only way to secure it with certainty consists in riveting over the end of the rod. Lock nuts and cotter pins have been tried, but not, it would seem, with all the success desirable. On some lines the tapered portion of the rod is screwed into the piston. The piston packing is always very simple. Many years ago Mr. Ramsbottom introduced on the London and North Western Railway three plain steel rings, each cut through in one place. These rings are about $\frac{3}{8}$ inch square, and are slipped each into one of three similar grooves turned in the circumference of the piston,

and their own elasticity is sufficient to keep them pressed steam-tight against the cylinder walls. Ramsbottom rings are still very and deservedly popular. They had not been long before the world before a precisely similar arrangement—in all respects but one—known as Swedish packing, was introduced. The difference lay entirely in the breadth of the rings. Two, from $\frac{3}{4}$ inch to 1 inch wide and about $\frac{3}{8}$ inch thick, are used, as shown in Fig. 71. This packing, or some slight modification of it, is to be found to-day on nearly every railway in the world. When the steam is superheated very special arrangements are required. It may be added, perhaps, that many other packings have been invented, patented and tried. But the advantage, if any, which they have is too small to get them into use.

CHAPTER XXVIII

VALVE GEAR

THE action of a slide valve, and the way in which steam is admitted to, and discharged from, a cylinder has already been explained in a rudimentary way. In practice the valve gear of the locomotive has been made the subject of much invention, and of papers and disquisitions in every European language, which would fill volumes. Simple as the operation seems to be, yet so much depends on its satisfactory performance that it has always proved an attractive subject for consideration. The problems presented, thermodynamical and mechanical, lend themselves freely, and indeed temptingly, to a mathematical treatment which would be out of place in this volume. But much can be said quite apart from mathematics to make it clear not only what the valve gear of a modern locomotive is, but why it is what it is.

We have seen that the normal slide is moved backwards and forwards on its seat, placing each side of the piston alternately in communication with the steam chest in which the slide valve works, or with the exhaust nozzle.

Among the numerous inventions which have been intended to cause the movement of the slide valve, only three are in regular extensive use. These are known as Stephenson's link motion, Joy's radial gear, and Walschaert's gear. The first two are extensively used in this country. On the Continent, Walschaert's gear is the favourite; in the United States, Stephenson's.

In the first locomotives working the Liverpool and Manchester Railway, that is to say, the real progenitors of the modern railway engine, motion was imparted to each slide valve by two

eccentrics. An eccentric is neither more nor less than a crank with a crank pin of great diameter. The "throw" of an eccentric, that is, its virtual crank length, is measured from the true centre of the eccentric disc to the true centre of the crank axle. As the eccentrics could not be put on the crank axle because of the cranks, if they were each made in one piece, they are made in two parts, secured together by sunken bolts. Each eccentric rod had at the end what was known as a "gab" or notch, which dropped on a pin at the end of the valve spindle. One of the eccentrics was set for going ahead, the other for going backwards, and levers were so arranged that the driver on the footplate could lift the go-ahead gabs off the valve-spindle pins and drop the go-astern gabs on when he wished to reverse his

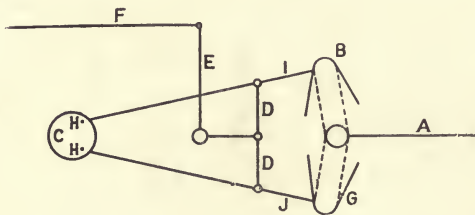

FIG. 72.

engine, and *vice versa*. But it was quite certain that, when the go-ahead gabs were lifted off, the valves would be in such a position that the go-astern gabs would not drop on. A very simple expedient got over the difficulty. The gabs were made with long horns as shown in Fig. 72 at B G. The distance between the horns being greater than the travel of the slide valve, it mattered nothing at all what position the slide valve might be in. It was only necessary to push down the eccentric rod hard, and the horn would slide along the spindle pin, and move the valve until the gab dropped on to it. At the first, two reversing levers were used, one for moving the go-ahead, and the other the go-astern eccentric rods. Then a bell crank was added, and a single reversing lever F raised one and dropped the other pair of gabs. The next important invention consisted in simplifying the whole arrangement by turning the go-astern gab upside down, and coupling the two rods I J, by two links D D to the bell crank E, which was moved by a single reversing lever on the footplate by the rod F. In the sketch, A is the slide-valve spindle, B and G

the horned gabs, C is the crank axle, H H the centres of the excentrics. A single movement then sufficed to lift one gab out of gear and to lift the other in.

The reader will see that so long as the gab was retained, the travel of the slide valve must remain constant. There was no means of varying the quantity of steam admitted to the cylinders but the regulator. What this involves will be explained presently. In the early years of railway history little thought was given outside a very narrow circle to the expansive use of steam in locomotive engines. However, even in its improved form, the gab gear was not quite satisfactory. It was noisy. It wore out rapidly. If there was any steam in the valve chests the resistance was so great that the horn would not move the valve, and when the engine was running fast it was not pleasant gear to handle.

Various inventors sought improvements, and finally arrived the link motion. The genesis of this is doubtful, and a keen controversy exists as to the way in which it came into being.

So far as can be ascertained, a pattern maker named Howe showed Robert Stephenson a model of an invention which, to judge from the drawings existing, would not work. He used extremely short excentric rods, and coupled their ends by a slotted bar or link. Into the slot was put a pin on the end of the valve spindle, and by moving the link up or down, either one excentric or the other drove the valve. But the rods were so short that the excentrics could not get round. Nevertheless, here in one way was the rudimentary idea of the link motion. In 1898, Mr. W. P. Marshall read a paper before the Institution of Civil Engineers on "The Evolution of the Locomotive Engine." Speaking of valve gear, he writes: "In 1841, when I was Locomotive Superintendent of the North Midland Railway, I was making trial of different valve motions for Mr. Robert Stephenson, and on the 15th December, 1841, Mr. Stephenson came into the locomotive office, Derby, on the way back from Newcastle, and said, 'There is no occasion to try any further at scheming valve motions, one of our people has now hit on a plan that beats all the other valve motions,' and he then explained the slotted link. In 1842 an

engine with the link motion was delivered by Messrs. Stephenson & Co. to the Northern Midland Railway." No particulars are available of this engine, but the probability is that the motion was very like that now in use.

The entire episode is very curious. It illustrates the way in

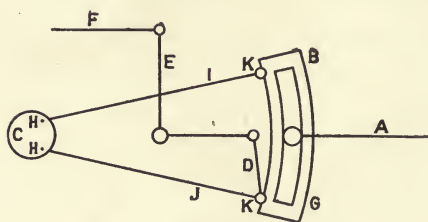

FIG. 73.

which the obvious is sometimes missed. If the reader will examine Fig. 72 he will see that if the ends of the horns were joined together the links D D might be dispensed with. Instead of the gabs being in one

piece with the rods, pin joints would be needed at K K. If, further, the horns were closed in as shown by the dotted lines, the link was at once obtained. To curve it to the radius of the excentric rods would follow as a matter of course, and the link motion as shown in Fig. 73 would then be complete. The gear is always identified with Stephenson, and it seems probable that while he was, so to speak, put on the track by Howe, he really followed much the line of reasoning just sketched out, and so produced a valve gear which is immortal among mechanical devices.

CHAPTER XXIX

EXPANSION

It is desirable here to interrupt the description of valve gear, and deal with general principles, because until these are mastered the reason why valve gears are not all alike will not be apparent.

It is assumed that the majority of readers understand the great principles of thermodynamics sufficiently well to appreciate the nature of the advantages gained by working steam expansively. Nevertheless, in pursuance of the scheme of this book, it is necessary to offer here a few words of explanation.

Let us suppose that a gear is in use, and that the cylinder is, when the piston reaches the end of its stroke, nearly full of steam. It will not be of much less pressure than that in the boiler. Suppose the capacity of the cylinder is two cubic feet, and the cylinder pressure at the moment the exhaust opens is 75 lbs. per square inch, then two cubic feet of steam of that pressure is blown into the atmosphere to waste; yet it is quite obvious that there is plenty of work still in this steam. Let us suppose now, further, that the supply of steam to the cylinder is stopped when the piston has gone half way, the exhaust remaining unchanged. It follows that at the end of the stroke we shall have one cubic foot of steam at 75 lbs. pressure supplied, which becomes two cubic feet at the end of the stroke. Its volume is doubled and its pressure will be half 75 lbs., or 37.5 lbs. Thus not only shall we use only half the total quantity of steam used before, but we shall send that half up the chimney with only one-half as much available work in it. The loss so far will be reduced to one-fourth of what it was.

It must, however, not be forgotten that the work done in the cylinder at each stroke, therefore, at each revolution of the driving

wheel will be less than before; but not so much less as to neutralise the economical advantage gained. This will best be made clear by a numerical example. Let a cylinder be 17 inches in diameter; the piston surface 227 square inches; length of stroke 24 inches; capacity of cylinder $227 \times 24 = 5,448$ cubic inches; pressure of steam 150 lbs., working without expansion, steam being admitted for the whole stroke; piston speed 600 feet per minute; we have then $\frac{227 \times 150 \times 600}{33,000} = 619$ h.p.

Next let us suppose that steam is cut off at half stroke, all the other conditions remaining the same. The quantity of steam used per stroke will then be 2,724 cubic inches; the average pressure will obviously be less than 150 lbs. It will be 150 lbs. up to half stroke, and it will be 75 lbs. at the end of the stroke. The average pressure is found by the following rule:—

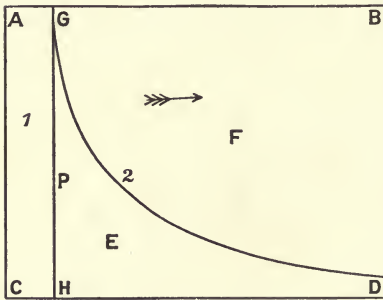

FIG. 74.

Add 1 to the hyperbolic logarithm of the ratio of expansion. Multiply the result by the initial pressure, and divide by the ratio of expansion; the quotient is the average pressure. The ratio of expansion is 2, and the hyperbolic logarithm of 2 is .6931. We have, therefore, $\frac{1.6931 \times 150}{2} = 103.965$ lbs. as the average pressure, or, in round numbers, 104 lbs., and

$$\frac{227 \times 104 \times 600}{33,000} = 426 \text{ h.p.,}$$

that is to say, we get about two-thirds the power for one-half the steam.

For a full explanation of what a hyperbolic logarithm is, the reader is referred to any treatise on logarithms. A gas expanding exerts pressure in an inverse ratio to the space it occupies. The curve of falling pressure is therefore a hyperbola.

The accompanying diagram, Fig. 74, will, it is hoped, make the facts clear. Here we have a piston P moving in a cylinder A B C D. The first portion of the stroke A G C H being made with full pressure, is denoted by 1 in the formula given above. The second half of the stroke being done expansively, we have our hyperbolic curve of falling pressure, shown by the line 2. The logarithm denotes the proportion which the space E, which represents work done during expansion, bears to the area of the rectangle A G C H, which represents the work done during the full pressure part of the stroke.

In the following table are given a few of the hyperbolic logarithms most likely to be wanted in locomotive practice:—

HYPERBOLIC LOGARITHMS.

Ratio of Expansion.	Hyperbolic Logarithms.
2·0	0·6931
2·5	0·9163
3·0	1·0986
3·5	1·2528
4·0	1·3863
4·5	1·5041
5·0	1·6094
5·5	1·7047
6·0	1·7918
6·5	1·8718
7·0	1·9459

It must be understood that what has just been said is intended only to exemplify a principle. The expansive working of steam is really not simple, but complex. The ratio of expansion is always less than that given above, because the piston does not touch the cylinder cover; and the clearance space, as it is called, is filled with steam, so that the whole quantity expanding is greater than is represented by the volume swept out by the piston at each stroke. Again, steam is always condensed when it first enters the cylinder, unless it has been superheated; and the expansion curve is never a true hyperbola, except by accident. The reader possessed of a fair knowledge of Thermodynamics

does not need detailed explanations of what takes place inside a cylinder. The reader who does not, has had so much explained as will enable him to comprehend what follows about the action of the Stephenson link, and nothing more is necessary here.

Let it be supposed that the slide valve is made of such a length that when in the middle of its stroke it just covers all the ports. Then it follows that if it is moved either forward or backward it will admit steam to the front or back end of the cylinder. Under such conditions there could be no expansive working. The steam must follow the piston full stroke, because the moment steam was cut off at one end of the cylinder it would be admitted at the other.

But let the valve be lengthened, so that it will more than cover the ports. Under these conditions, as shown in the diagram Fig. 67, and the sectional drawing Fig. 79, both the valve and the piston would have to move some distance before the port opened for the admission of steam. But the valve would also cut steam off before the stroke of the piston was complete. Here then we have expansion. If now the excentric, instead of being set at an angle of 90° with the crank, is moved forward, then we shall have steam admitted at the beginning of the stroke, and cut off before the end. The extra length of valve is called the "lap"; the angular advance of the excentric is called the "lead," and the lap and lead, it will be readily understood, are two very important factors in the working of the valves of a locomotive engine. The lead virtually cancels the lap so far as admission is concerned, and augments it by an equal amount so far as cut-off is concerned.

In Great Britain long practice has fixed 1 inch as the amount of lap which best meets all the working conditions. In a few cases it is only $\frac{7}{8}$ inch, while in others $1\frac{1}{8}$ inch has been tried. But 999 out of every 1,000 locomotives fitted with slide valves have a lap of 1 inch.

Now if a slide valve has a lap of 1 inch, when it is at rest in mid stroke it overhangs the port at each end by 1 inch, and it must be moved at least 1 inch in either direction before it will open a port. It will be seen, therefore, that the valve spindle

pin must be some way from the centre of the link in either direction before the engine can take steam. Furthermore, let it be supposed that the arrangement of the valve gear is such that steam is cut off in one cylinder at something less than three-quarter stroke. It will then be admitted to the other cylinder while the crank is near the dead point. Then, with a moderately heavy train, the engine will not start. In railway phraseology "she has gone blind," that is to say a port is blinded or stopped by the lap on the slide valve, and the piston which would pull the crank round gets no steam or is so near the dead point that it cannot start the train. To get the engine to start, it must be reversed in order to put the valves into a new position. Every railway traveller has seen the regulator opened and no result follow. Then he has seen the reversing screw turned, and the whole train pushed back a yard or so. Then the wheel being again turned the valves are put in full forward gear and the train goes on its way. One reason for keeping lap down to an inch is that the longer the lap the greater is the risk of the engine going blind.

Lap and lead can be so adjusted to each other that when the engine is in full gear for running in either direction, the steam will always be cut off at a fixed point of the stroke. What this fraction may be varies. Generally speaking it may be taken at about 75 per cent., but the old gab gear would do as much. The link when in full gear is only the gab improved mechanically in constructive detail.

If now, leaving everything else as it was, we shorten the throw of the valve, it will be seen that the steam port at each end, although not opened fully, may be opened sufficiently to admit steam; but the shorter the stroke of the valve the less time will the port remain open. In other words, the shorter the stroke of the valve the earlier in the stroke of the piston will steam be cut off, and the higher will be the ratio of expansion. The stroke can be shortened by moving the link so that the valve spindle pin is not at the end of the link, but somewhere nearer the middle of its length. In this way the Stephenson link possesses the great merit of giving the driver the power of varying the amount

of expansion. When climbing a hill, for instance, he puts the engine in full forward gear to get the maximum pulling effort. On a level he "links her up," and cutting off earlier he works expansively.

It is most important that the student should master completely the parts played by lap and lead. If these are once understood there will be little difficulty in following out the details of any gear however complicated. To this end no mathematics are needed. The facts may be readily mastered by cutting a valve in section out of thin cardboard, and moving it backwards and forwards on a section of the port face. The diagram Fig. 67 may be utilized for this purpose.

CHAPTER XXX

THE STEPHENSON LINK MOTION

UP to this point, the link has been spoken of as moving on a fixed centre coincident with the centre of its own length. No such condition, however, exists in a locomotive ; on the contrary, the real movement of the link is very complicated. The geometry of the link motion has been made the subject of careful study by mathematicians. The reader will find at the end of the volume

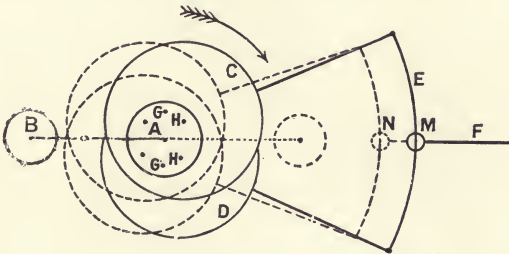

FIG. 75.

a list of authors who may be consulted on this subject with advantage. Nothing more can be dealt with here than principles.

It will be seen that if the eccentrics were placed opposite each other, a line drawn through their centres also passing through the centre of the axle, the link might be carried on a fixed pin at the centre of its length, on which it would rock backwards and forwards. In that case only one eccentric would be required as in Walschaert's gear. But a line drawn from centre to centre of the eccentrics cannot pass through the centre of the axle because of the angular advance or lead of each eccentric.

The sketch, Fig. 75, will make this clear. Here A is the crank

axle, B is the crank pin, F is the valve spindle, C is the go-ahead excentric, D is the go-backwards excentric, E is the centre line of the slot in the link. If now there were to be no angular advance of the excentrics, and no lead, they would be so keyed on the axle that their centres H H would fall on a vertical line uniting G G. They would consequently be set each at an angle of 90° with the crank, and the link could rock, as stated above, on the centre M, and when the reversing lever was in mid gear the slide valve would have no movement. But the centres of the excentrics not being opposite to each other, their throws do not neutralise each other. Let the dotted lines show the position when the crank has made half a revolution. It will be seen that a vertical line joining the centre of the excentrics has now been carried as far behind the centre of the crank axle as it previously was in front of it, and the whole link, and with it the valve spindle F, has been shifted through a distance equal to that between N and M. Consequently there is no position in which the slide valve can be absolutely at rest while the engine is running. A curious result, by no means generally known, is that if a locomotive is running chimney first and the link is put in mid gear, the engine will continue to run forward because the valve will give a little steam to the cylinder at each end of the stroke by reason of the movement M N. If the engine happens to be running tender first, then in like manner it will continue to run backwards. Of course, it must be understood that the loads are light. A search for an explanation of this phenomenon will constitute an interesting exercise for the student.¹

As no point in the link is at rest when the engine is in motion, and the link as a whole is moved backwards and forwards as well as each end, the link must be itself carried by a link, which may be pivoted at the top, at the bottom, or in the middle, no matter which, so far as the movement is concerned. This suspending link, playing like a pendulum, causes the centre of the main link to rise and fall, through only a small distance it is true, yet small as it is it affects the travel of the valve. The

¹ The author's attention was first called to this fact by the late Sir Frederick Bramwell.

usual practice is to suspend the link by the middle, occasionally at the lower end, never by the top in the present day. A further complication is introduced by the angular movement of the connecting rod. The piston is not in the middle of its stroke when the crank is vertically up or down by an amount equal to the versed side of the arc described by the big end of the rod. All difficulties have, however, been got over, and a well-designed Stephenson gear gives a completely harmonious action of the slide valves, and is in every way but two quite satisfactory. The lead is not constant in the first place,¹ and in the second, when the engine is working expansively and running fast, the admission port is never opened fully and is kept open only for a minute fraction of a second. The result is that steam is wiredrawn, and it is impossible to get a good pressure in the cylinder, and for the same reason the exhaust is throttled, and the exhaust port closed too soon. Various means of getting over the difficulty have been schemed, but as none of them are in use, save experimentally, no more need be said of them here.

The details of construction are very simple and so familiar that no further illustrations are necessary. The link is dropped down for running chimney first, and raised up for running backwards. A weigh bar runs across under the barrel of the boiler, and is carried in plain bearings bolted to the main frames. On the weigh bar are keyed four arms. Two of them, extending forward, carry each one of the links by a pair of sling bars. The third, always placed halfway between the frames, extends backwards and carries a cheese-shaped block of cast iron, which exactly balances the weight of the links and half that of the excentric rods. The fourth arm usually stands up at the side of the boiler, and to it is joined a long flat bar extending to the driver's cab. Here in the older locomotives it is coupled to the reversing lever, which moves in an arched guide, provided with notches into which drops a detent, which can be lifted out by a small subsidiary lever just in front of the handle. When the reversing lever is drawn back the link motion is raised by the

¹ The student will do well to master the effect of "crossed" and "open" excentric rods on lead.

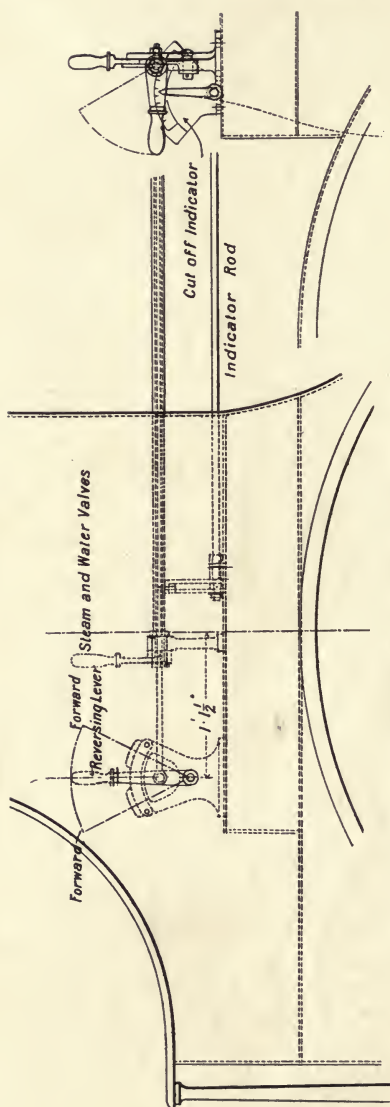

FIG. 76.—Wainwright's reversing gear.

weigh bar and the notch in which the detent is placed determines the point of cut-off and, as explained, the ratio of expansion. Too much precaution cannot be used in securing the balance weight, which is very liable to work loose and fall off. A terrible accident occurred some years ago on the Great Eastern Railway. Two trains were about to pass each other when the balance weight of one engine fell on the line and, rolling under the other train, derailed a wheel and threw the engine off the rails. In the United States the balance weight is seldom used. It is replaced by a powerful coiled spring round the weigh bar shaft or a flat transverse spring between the frames. The reversing lever has been superseded in all modern locomotives by a hand-wheel and quick threaded screw.

In many modern engines power is employed with much ingenuity to work the valve gear. About 15 years ago Mr. Stroudley, Locomotive Superintendent of the London, Brighton & South Coast Railway, used the air pressure

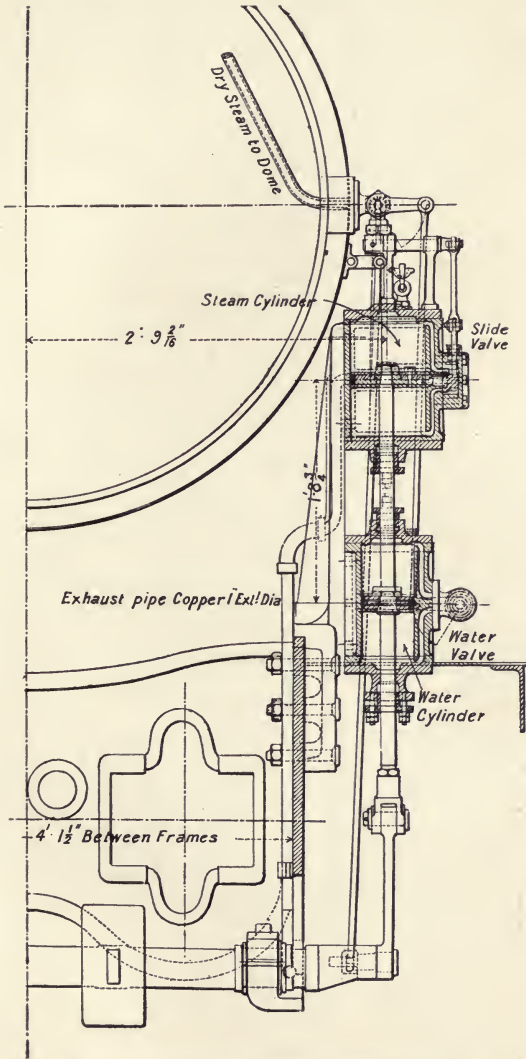

FIG. 77.—Wainwright's reversing gear.

of the Westinghouse brake for this purpose. More recently Mr. Drummond, of the London & South Western Railway, fitted steam

reversing gear to his largest engines. Then Mr. H. Wainwright, Chief Mechanical Engineer, London, Chatham & Dover and South

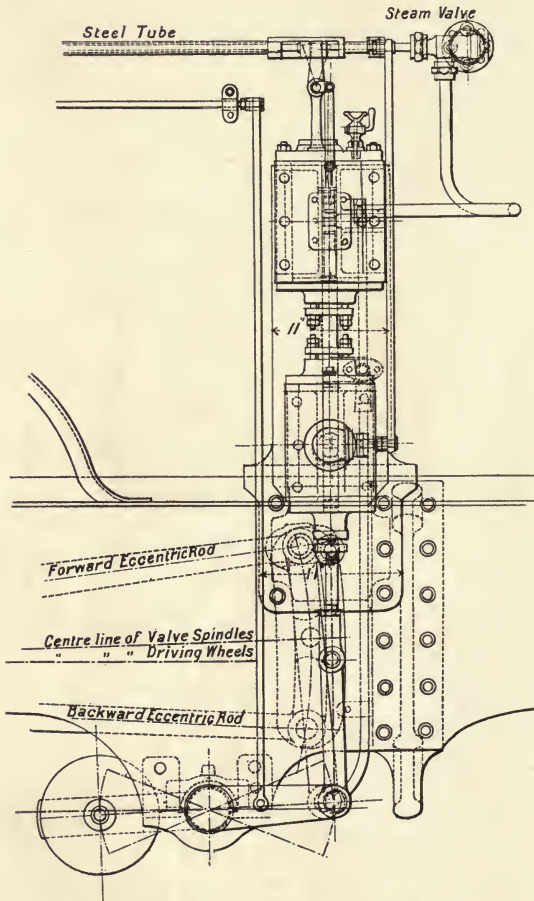

FIG. 78.—Wainwright's reversing gear.

Eastern Railway, designed, and has for a long time used, the arrangement illustrated by Figs. 76, 77, and 78. At the right-hand side of the boiler barrel is fixed a small vertical bed plate carrying a steam and a water cylinder shown in section in Fig. 77.

The admission of steam to the upper cylinder is controlled by the small slide valve shown in the section Fig. 77. This is worked from the footplate by a miniature reversing lever; a second lever controls the admission of steam and water.

The lower cylinder is what is known as a "cataract"—a term derived from old Cornish engine practice—a leather-packed piston having water at both sides of it. Water being incompressible, so long as that in the cataract cylinder is locked up the piston cannot move. The upper or steam cylinder piston being on the same rod, it also is fixed. It follows, therefore, that the rod being linked as shown to the weigh bar, already mentioned, of the Stephenson valve gear, the gear is efficiently locked in position by the cataract. If the driver wishes to reverse the engine he can turn on steam to the steam cylinder above or below the piston, as he wishes to go backwards or forwards, by altering the position of the slide valve, to the steam chest of which he has admitted boiler steam. But the piston cannot rise or fall until the position of the water-cock is changed and water is permitted to pass from one side of the cataract piston to the other. A small indicator moving on a plate in the cab shows the precise percentage of the stroke during which steam is admitted. The details are so clearly given that further description does not appear to be required. This reversing gear acts with great steadiness. No labour or risks are incurred by the driver in handling the engine, and the point of cut-off can be settled with much greater minuteness than is possible with a lever and a notched quadrant.

CHAPTER XXXI

WALSCHAERT'S AND JOY'S GEARS

THE principles involved in the construction of Walschaert's gear are in many respects identical with those of the Stephenson link, lap and lead playing the same part. Let us suppose that it is hung on a fixed pivot in the middle and worked by a single excentric only. The excentric rod being attached to the link at the lower end, the excentric must be keyed on the crank axle precisely at right angles to the crank, and the crank will rock backwards and forwards on its centre pin. If now the pin at the end of the valve spindle were placed at the upper end of the link, the engine would go ahead. To reverse it we have only to drop the pin to the bottom of the link. The length of the travel of the valve will be determined by the place of the pin in the link just as it is with the Stephenson link. But such an arrangement gives no lead. This might be got, however, by giving the excentric sufficient angular advance. But if this were right for going ahead, it would be absolutely wrong for running backwards, and therefore quite unfit for a locomotive. In practice, as the gear is usually fitted to outside cylinders, no excentric is used. Instead, a small counter crank is carried by the main crank pin, and this, precisely at right angles to the main crank and much shorter, is coupled by a plain straight bar to the reversing link.

Lead is obtained in the following way. The radius rod, that is to say, a rod one end of which can be raised or lowered in the rocking link, is not coupled directly to the valve spindle, but to a swinging or "floating" lever. To the upper end of this the valve spindle is jointed. The lower end of it is coupled to the cross head by an arm extending downwards. A glance at the

engraving on p. 232 will suffice to show that when the piston has reached the end of the cylinder, the slide valve will have been pushed forward by the floating lever, and nothing more is required to get the precise amount of lead wanted than to proportion properly the lengths of the two arms of the swinging lever.

Fig. 79 shows this gear as fitted to the high pressure cylinder of an American compound engine of the celebrated De Glehn type. The engine has a balanced slide, the pressure being kept off the top of it by a ring fitted with packing to the inside of a second ring, the upper edge of which moves steamtight on the lid of the valve chest. A is the crank axle, B is the counter crank, forged in one with the crank pin. D is the link, which rocks on a fulcrum pin which does not pass through the centre, and so leaves the curved slot in it clear for the traverse of a die on the end of the radius rod E.

From the cross head descends a fixed arm F, which is united to the floating lever G by a link. The upper end of G swings on a pivot J, in an extension I of the valve spindle H.

The leading end of E is pivoted to G, about $3\frac{1}{4}$ inches under J. The floating lever is carried by I, which moves, as shown, in a long guide. The dotted lines show various positions of D as the driving wheels revolve. L is a bell-crank lever, worked from the footplate, which shifts E up and down. It is clear that, as has been explained, the movement of H will be a compound of that of F—otherwise the piston—and D. For let us suppose that C is disconnected, and the link D held fast, then let the piston make its stroke; G turning then on the pin in the end of E as a fulcrum would move the slide valve in an opposite direction to the motion of the piston. Or let the connecting rod be taken down, and the piston held fast while the crank shaft was revolved; then as D rocked, G would turn on the pin at its lower end as a centre, and the slide valve would be pushed backwards and forwards through a slightly greater distance than the travel of the link.

In the engine shown the stroke of the cross head is $25\frac{3}{16}$ inches. The diameter of the circle described by the

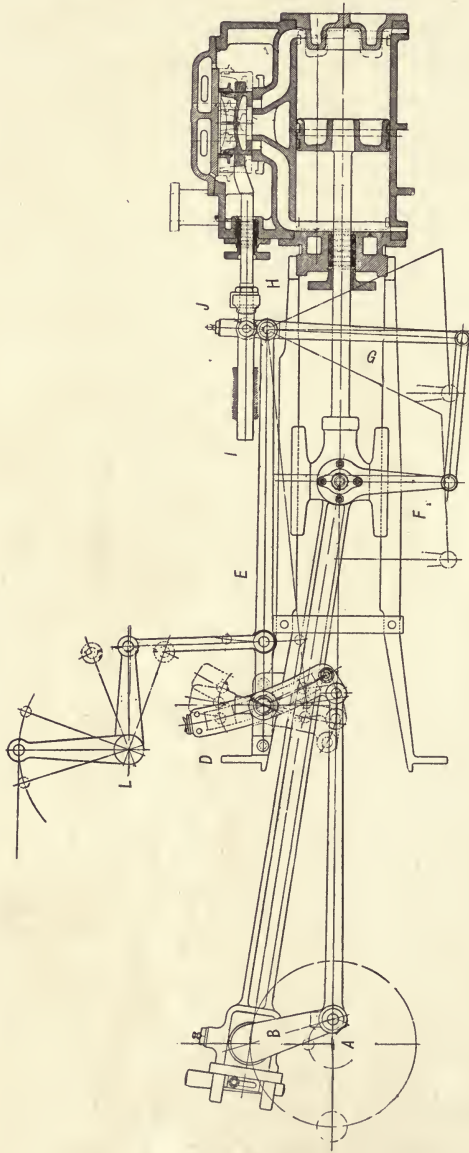

Fig. 79.—Walschaert's gear.

counter crank pin is $7\frac{3}{4}$ inches. The long arm of the floating lever is $29\frac{1}{2}$ inches between centres, and the short arm is $3\frac{5}{2}$ inches. The radius rod I is $57\frac{3}{2}$ inches long between centres.

The geometry of this gear is very elegant; but on the whole it is much more simple than that of the Stephenson link, because the radius link D has no motion but one; it rocks on a fixed centre. The action is very satisfactory, and it is not really more complex than other gears.

For compound locomotives the Walschaert gear is easily applied to inside cylinders, a single excentric being used for each cylinder. Thus the low pressure inside cylinders of Fig. 79 are so fitted.

Joy's radial valve gear acts on a principle quite different from those just described.

As has been stated, a great number of radial gears have been invented and tried—this is the only one which has been adopted for locomotives to any extent. It was invented by the late David Joy many years ago. Mr. Joy was one of the pioneers of the railway system, and his great experience with locomotives enabled him to avoid mistakes made by other inventors possessing less practical knowledge.

Let us suppose that a link A (Fig. 80), similar in its nature to either of the two described above, is pivoted at the centre of its length B, but that it can be moved on this centre by the arm C and rod D, or held fast so as to stand at different angles. Further, let the valve spindle E be jointed at one end to a long bar F, called the radius rod, a pin at the other end of this rod entering the die G in the link. As the length of the rod is equal to the radius of the curve to which the slot in the link is struck, it is clear that if the pin is moved up and down in the link by the rod H, while the link is held straight up and down, no motion will be produced in the valve. If, however, the link is inclined in either direction as shown by the dotted line, then as the pin moves up and down in the slot, the valve will be moved

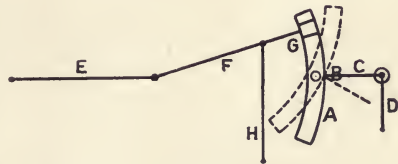

FIG. 80.

backwards and forwards, and to reverse the engine it is only necessary to alter the inclination of the link. There is here no excentric or secondary crank. The motion of the valve is caused by the sliding up and down in the radial link of the die at the end of the radius rod which is jointed to the valve spindle.

But the same conditions hold for the Joy radial link as those obtaining with the Stephenson or Walschaert link—there is no lead. The objection is got over, however, in just the same way, by the aid of a floating lever. The practical application of the gear is shown in Fig. 70.

The links are heavy steel castings in one with a weigh shaft C carried in bearings secured to the main frames. In each of these is a hardened die or rectangular sliding block, curved of course to fit the link D, and to this block is pivoted the floating lever E, to the upper end of which is pivoted in turn the valve spindle connecting rod. To alter the ratio of expansion or to reverse the engine nothing more is required than to change the angle at which the radial link stands, and this is done from the footplate, through the bar G, either with a lever or with a hand-wheel and screw.

The die is caused to move up and down by coupling it with the connecting rod. As the movement of this rod would be too great, a secondary link is introduced, as shown in the illustration. The angles and movements are shown by the dotted lines. The geometry of this gear is somewhat complex; it will be found in most treatises on valve gear.

Joy's gear is exceedingly good, giving an excellent diagram, and it possesses the great merit that it permits the use of large inside cylinders, the valve chests being placed on the tops of the cylinders instead of between them. When properly made, with large and well-hardened surfaces in the links and dies, it works with less friction than the excentrics of Stephenson's gear. It is very easily kept in order and, furthermore, it has the great merit that the lead is constant for all positions of the link. With the Stephenson link the lead varies. We have seen that it depends for its amount on the angular advance of the excentrics,

which instead of being set at 90 degrees with the cranks are usually set about 18 degrees forward. But the advance of the excentrics is virtually settled not only by their relations to the cranks but by the position of the excentric rod. It is in effect the same thing, whether we move the excentric round on the axle, or the excentric hoop round on the excentric, the lead will be altered in either case, but the place of the die in the Stephenson link cannot be altered without moving the excentric hoop round on the sheave. Both Joy and Walschaert gears have a constant lead, that is to say, steam is practically always admitted when the piston is in the same position near the end of the cylinder, no matter when the cut-off takes place.

CHAPTER XXXII

SLIDE VALVES

It is hoped that the reader has now formed clear ideas as to the mode of action of the three types of valve gear which are employed to the almost total exclusion of all others. It is true that modifications are in limited use; but it will be found that these almost invariably include some form of floating lever to get lead, while in others a species of combination of the Joy and Stephenson links is made, the die being caused to slide up and down in the link, without in any way interfering with the movement of the link when actuated by the reversing lever. The consideration of the advantages sought to be gained by improvements in valve gear must be postponed until we come to deal with the performance of locomotives as set forth by indicator diagrams.

Valve gear must be very substantial, with large and well hardened rubbing surfaces, because the work to be done is trying. The frictional resistance of a slide valve does not, it is true, absorb much power; but this is due to the circumstance that the stroke of a valve is short. Whether the stroke is an inch or ten inches affects the power expended but in no way modifies the stress to be overcome. A slide valve is forced down on its seat by the pressure on its back, the area over which this pressure is exerted being that of the exhaust opening in the valve and sometimes one and sometimes two ports in the seat according as one or two are covered by the valve. The whole surface of the valve is not to be taken, because when metal and metal are apparently in contact there is always a thin film of steam between them. A slide valve suitable for an 18-inch cylinder will have a "bridge" about 6 inches \times 17 inches, representing, say, 102

square inches, to which may be added the area of one port, say 17 inches \times $1\frac{1}{2}$ inch = $25\frac{1}{2}$, or a total in round numbers of 127 square inches. With steam at 150 lbs. in the valve chest, the total load carried by the valve, jamming it down on its seat, would be 19,005 lbs. or over 8 tons. What the co-efficient of friction is it is not easy to say, because it varies almost from minute to minute with the lubrication, the dryness or wetness of the steam, and so on. It probably varies between 1 and 10 per cent. It is greater with vertical than horizontal valves. The valve gear may therefore have to overcome a resistance of somewhere about 1,900 lbs. It is in no way remarkable that valve spindles break and eccentric hoops open out and heat, and valves wear away rapidly. To appreciate what goes on it is necessary to stand on the running board and watch the mechanism at work at various speeds when it is a little worn. The inexperienced observer will begin to ask himself if it is possible the engine can ever get to its destination.

Slide valves must be left free so that they can find their way to their seats. To this end they are always made with a rectangular projection on their backs, which fits into a frame known as a "bridle," usually forged with great care from the best scrap iron. Into one end of this—the bridle is much broader than it is long—is secured the valve spindle. As a rule the spindle and the bridle are now made in one piece, but formerly the bridle was made with a boss into which the valve spindle was screwed.

Occasionally a short length of rod is provided at the other end of the bridle; this passes through a bush in the front of the valve chest and acts as a guide for the spindle. There are various methods of supporting the outer end of the valve spindle; sometimes it is keyed into a bar, which has been turned on two centres. The larger part of this bar passes through a long brass bush or cylindrical guide in the motion plate. The end of the guide rod is forked, and the fork embraces the link and the die in it. A pin is then passed through the two jaws of the fork and the die block. This is a very simple, cheap, and durable arrangement, and has almost entirely superseded the sling links which at one time carried the back ends of the valve connecting rods.

It is an incidental defect in the mechanism that as the link is always rocking backwards and forwards the push and pull on the die are only momentarily normal to the valve spindle. The result is that the link continually tends to slip the die up and down, and, failing that, to fly up and down on the die when the gear is at all worn. The detent in the notched arc of the old-fashioned lever or the nut on the reversing screw in modern engines chatters continuously when the engine is running. The indirect action puts a heavy stress on the sling straps of the link and the guides of the valve spindles. Little of this kind takes place with the Walschaert or Joy gear.

Various attempts have been made at different times to take some of the pressure off the backs of the valves, and so reduce the stress due to friction and prolong the life of the valve. We need not concern ourselves with more than one or two. The Richardson balanced valve is an American invention, a modification of which is shown in Fig. 79. Essentially it consists of an ordinary slide valve, to the back of which is fitted a rectangular ring, one edge of which is seated in a groove running round the slide valve, while the other edge works steamtight on the polished inner face of the valve chest cover. Sometimes a circular projection on the back of the slide fits a ring, the top of edge of which bears against the lower. As steam cannot find its way past the ring, the slide valve is relieved of almost all the pressure on its back. This valve, however, takes up a great deal of room and can only be used when the slide valves are placed directly on top of the cylinders. It constitutes an excellent combination with Joy's gear.

Another balanced slide valve exhausts directly up through the back of the valve, which, as in the valve just described, is fitted with a balancing ring on the back. Within the last few years piston valves have begun to find favour, but these will be best dealt with in connection with compound and superheated engines.

CHAPTER XXXIII

COMPOUNDING

ALTHOUGH compound locomotives are not much in favour in this country they are in use on many European railways, and to some extent in America. They have formed a subject for discussion for many years, and it cannot even now be said that anything like a universally accepted decision has been arrived at. The reason for this want of unanimity will be understood as the reader proceeds.

It has been already shown that to secure economy the steam must be caused to expand so that it can be discharged from the cylinder at a much lower pressure than that at which it entered it. This means a reduction in the average pressure, and of course in the pulling power of the engine. This difficulty could be got over by putting in larger cylinders—that is to say, by augmenting cylinder capacity. Although the average pressure would be reduced, the pulling power of the cylinder would remain unchanged. The plan has been tried and failed completely for reasons which are worth stating because they show some of the difficulties which beset those who design locomotives.

In the first place, when the engine is starting, full pressure steam acts on the piston, and if this is large, then all the rest of the mechanism must also be large. Thus a crank axle big enough for a 17-inch cylinder will not suffice for a 19-inch cylinder, and so on. Consequently a heavy and expensive engine results. In the next place, the utilization of the large cylinder depends on the engine driver. He must "link up" his engine in order that the steam may be cut off early in the stroke and expanded. In practice it has been found impossible to get the men to do this. On inclines they give their engines too much

steam, and the result is that they "run them out of breath," and then complain that the boiler will not keep steam. It has been proposed to get over the difficulty by increasing the lap from one inch to an inch and three-eighths. Then the drivers could not help using steam expansively, because do what they would the cut-off would take place fairly early in the stroke. But this plan failed because the engines easily went blind. Much delay occurred at starting, and at the best of times the speed of the train rose too slowly. To get over the difficulty it has been proposed that a small hole should be bored into the valve seat at each end. Through this hole, when the engine was blinded, steam would get in and start the engine, and when speed was obtained, the small quantity that would find its way in could have little or no effect on the ratio of expansion. In the United States the same object is attained by filing a notch in the valve at each end, through which steam enough to start the engine could find its way. Neither of these methods has, however, attained any popularity. The problem remains unsolved. Steam was not used to the best possible advantage in the locomotive.

Then it was resolved to try compounding—that is to say, using the steam first in one cylinder and then, instead of turning it directly up the chimney, passing it on to another cylinder, precisely as in marine engines. As this book is intended to be of use to the non-technical as well as to the technical reader, it is necessary to explain in as few words as possible what compounding means. For detailed information the reader must consult any good work on the steam engine. It must, however, not be forgotten that the conditions and limitations under which the compound system can alone be applied to the locomotive render much that is written concerning stationary and marine engines inapplicable. This will be explained more fully presently.

Let us suppose that we have two cylinders of the same diameter side by side, each capable of holding two cubic feet of steam, and that pistons in these drive two cranks set at 180° from each other. Let the cylinders be vertical, then when one piston is at the top the other will be at the bottom, and so on

alternately. One of these cylinders is full of steam, with the piston at the bottom. The steam, instead of escaping into the atmosphere, is now admitted to the other cylinder and pressing on the piston forces it down. But the steam equally resists the rising of the first piston. The effort is balanced and no motion would be produced, and even if it were no expansion would take place. The action would be analogous to the pouring of a pint of water from one pint pot into another.

But let cylinder number two be 50 per cent. larger in diameter, its length remaining unaltered. Instead of holding only two cubic feet it will now hold four. Its piston will have double the area. If the steam at the end of the stroke exerts 5,000 lbs. on the first piston, it will exert 10,000 lbs. on the second, and we shall have a net driving force of 5,000 lbs. At the end of the stroke, when piston number one has risen from the bottom to the top of its cylinder and piston number two has descended to the bottom of its cylinder and all the steam has passed from the first to the second cylinder, we shall have four cubic feet of steam of, say, 50 lbs. pressure instead of two cubic feet of 100 lbs. pressure. That is to say, the steam will have been expanded twice; the ratio of expansion is 2 to 1. Furthermore, let us suppose that the steam had been cut off at half stroke in the first cylinder. Then when the piston had completed its stroke the steam would have been expanded twice in the first cylinder, that is to say, doubled its volume, and this steam admitted to the second cylinder would at the end of the stroke have been expanded four times, because we had only one cubic foot of it instead of two to begin with, and the capacity of the second cylinder is four cubic feet.

Here attention must be called to an important fact, namely, that the total expansion, no matter what the number of cylinders or ratio of expansion in each cylinder may be, is always the same as though the expansion had taken place in the low pressure cylinder only. If, for example, the capacity of the low pressure, that is the largest, cylinder is ten cubic feet, and only one cubic foot is admitted to the high pressure cylinder, then the ratio of expansion will be tenfold. In compound engines the steam

passes through two cylinders only. In triple and quadruple expansion engines it passes through three or four cylinders. In every one of these cylinders the ratio of expansion may differ, but in the end it all comes to the same thing as though the expansion took place in the low pressure cylinder only. One practical result is that horse power is calculated on the basis of the average pressure which should be attained in the low pressure cylinder, all the other cylinders being neglected. Of course it must be understood that this is only a general statement. Not only the total power but the distribution of power among the cylinders has to be ascertained, as far as possible. This last should be the same for all. If an engine with two cylinders indicates 1,000 h.p., then as nearly as may be 500 ought to be obtained from each cylinder. If three cylinders, then 333 h.p. from each, and so on.

Now the form of engines we have been considering is not suitable to the locomotive, save under special conditions. Instead of the cranks being opposite each other they are at right angles, and consequently when one cylinder exhausts the other is not ready to accept the steam. The difficulty is got over by working each cylinder as though the other did not exist. The high pressure cylinder exhausts into a vessel known as the "intermediate receiver," from which the second or low pressure cylinder draws its supply.

Lastly, instead of using two cylinders, one twice as big as the other, we may use three cylinders all the same size, the steam exhausting from one cylinder into two instead of into one of double the size; or, conversely, we may use two small cylinders exhausting into one large one. All these methods are used in daily practice. The first compound locomotives put into regular use were invented by the late Mr. Francis Webb, Chief Mechanical Engineer of the London & North Western Railway. They had two small outside cylinders, fitted with Joy's valve gear, which drove one pair of driving wheels, and one large inside cylinder which turned another pair of driving wheels. The two high pressure cylinders supplied the single low pressure cylinder, which exhausted in the usual way up the chimney.

Mr. Webb was followed by Mr. James Worsdell on the Great Eastern Railway first, and then on the North Eastern, who used two inside cylinders only, one much larger than the other.

No engines are now made anywhere on the Webb system. Before describing any of the systems of compounding in actual use it is necessary to explain the limitations and conditions referred to above, for these it is which determine not so much what is and is not possible as what is and what is not likely to be satisfactory.

It will be remembered that the clear space between the main frames of a locomotive for the 4 feet $8\frac{1}{2}$ gauge cannot exceed 4 feet $1\frac{1}{2}$ inches. If a double cylinder compound is used it will be found that the small cylinder cannot be much less in diameter than it would have been if one of a non-compound pair, because increased cylinder capacity is essential, and that cannot be had if the high pressure cylinder is reduced in volume in proportion to the increase in volume of the low pressure cylinder. Now we have seen that two 18-inch cylinders represent the most that can be got between the frames unless the slide valves are put on top of them or underneath them. But an 18-inch high pressure cylinder requires a low pressure cylinder about 26 inches in diameter, and to squeeze this into 4 feet $1\frac{1}{2}$ inches, keeping their axes parallel and in the same plane, is not easy. Again, the larger pistons weigh more than the smaller pistons, and this entails trouble with balance weights. In a word, the engine is not symmetrical. For this and for other reasons connected with the details of construction, when two compound cylinders only are used in the present day, they are almost invariably outside cylinders. Plenty of room is in this way got, not only for the valve gear, but for the intermediate receiver, which in the locomotive takes the form of a large pipe carrying the exhaust steam from the first to the second cylinder. The pipe is often coiled round the inside of the smoke-box to get capacity in the form of length, while the steam passing through it is to some extent dried by the high temperature in the smoke-box.

In Mr. Webb's engines symmetry was obtained, but the engines were defective in various ways. The large inside

cylinder could do nothing until steam reached it from one or other of the high pressure cylinders. It followed that the starting of a train depended on one cylinder about 15 inches diameter. The consequence was that heavy trains got away with difficulty. Very often they could not start at all but for the fact that the rear driving wheels were made to slip on the rails, and so steam found its way to the large cylinder. At the best of times the starting effort was very unequal and the train advanced by jerks under the intermittent action of the single inside cylinder. Passengers did not like this. For long runs the Webb locomotive was fairly successful; whether it was or was not economical remains to this day a disputed question.

The starting of trains by two-cylinder compound engines has always presented a difficulty, as only one cylinder can get boiler steam, and if its crank is on or near the dead point the engine will not move. To get over this difficulty a special valve has to be added which will admit steam to the low pressure valve chest, the engine starting non-compound, which valve is closed subsequently. But it would not be safe to admit high pressure steam to act on the large, low pressure piston. The piston rod might be bent or the crank axle broken, therefore a reducing valve must be introduced, that is to say, the steam has to lift a valve loaded by a spring. If the pressure rises too high in the low pressure valve chest, then there is not sufficient difference in pressure to overcome the resistance of the spring, and the valve closes. Usually the maximum pressure permitted in the low pressure cylinder is about one-third of the boiler pressure, say 50 lbs. where the latter is 150 lbs.¹

If the intercepting valve, as it is called, is worked from the footplate, then the driver after he has started his train may forget it, or purposely leave it open, and we have then a bad non-compound engine. To prevent this Mr. Von Borries, a German engineer, invented a very ingenious automatic intercepting

¹ In some recent locomotives the intercepting valve is not used, the parts are made strong enough to take the full pressure. These engines are four-cylinder compounds, two high and two low pressure, and the subdivision renders all the cylinders comparatively small.

valve, which is open while the pressure in the low pressure valve chest is below a certain fixed limit, and closes of itself as soon as the engine has fairly started its train. Joining with Mr. James Worsdell, they patented a combination of the two-cylinder compound and the automatic intercepting valve, the result being Worsdell and Von Borries' patent engine, which with various modifications has been extensively used abroad.

CHAPTER XXXIV

PISTON VALVES

THE modern big locomotive is about twice as powerful as were its predecessors. The express engine of ten years ago seldom had more than 1,200 feet of heating surface. The modern engine has 1,800 to 2,000 feet in Great Britain, much more in the United States and on the Continent. Large cylinder capacity is required to use up the steam produced in the enormous boiler. Engines have been made with very large outside cylinders, but recently it has been deemed advisable to use four cylinders instead of two. Usually these are arranged side by side, two inside and two outside. In some cases the engines are simple, in others compound. An immense advantage is gained in that the reciprocating parts, moving simultaneously in opposite directions, balance each other, and no balance weights, or next to none, are put into the wheels. The rails are spared "hammer blow," and there is no jumping at high speeds. In the United States two types are made, one the invention of Mr. Vaucelain, and the other the invention of Mr. Cole, both engineers well known in the American railway world. The four-cylinder engine has rapidly grown in favour with the demand for very large powers. In Europe locomotives both compound and non-compound are in use. In Great Britain its adoption has been more leisurely, presumably because the demand for mammoth engines is not very considerable. It would be out of place to consider here the various types of construction found on different lines. The reader is referred for detailed information to the fine work "La Locomotive Actuelle," by M. Maurice Demoulin, published in 1906 by Beringer, Paris.

The slide valve has already been dealt with very fully. It is

now time to speak of more recent methods of distribution rendered necessary by the increase in power and the augmented pressure peculiar to recent locomotives.¹

About thirty years ago boiler pressures seldom exceeded 130 lbs. They were gradually augmented, however, as trains became heavier, until 150 lbs. was reached. Then came the compound engines, and it was very soon found that 150 lbs. was not enough to get advantage from compounding. M. de Bousquet, Locomotive Superintendent of the Chemin de Fer du Nord, adopted 220 lbs., and his example has been freely followed. It is not too much to say that an unbalanced slide valve cannot be successfully worked at this pressure even when saturated steam is used. When the steam is superheated an unbalanced slide valve cannot be used at all, because it will seize on the seat, and something must give way. The consequence is that piston valves are used for distribution. Nominally their construction is exceedingly simple, really their use is attended with certain objections to overcome which complications have been introduced. Probably fifty kinds of piston valves have been invented, and about half as many are in use. The differences lie in constructive details, for in principle they are all the same, and it will suffice to illustrate the first piston valve that attained success in this country. It was invented by Mr. Smith, of the North Eastern Railway, some ten or twelve years ago, and used with much success by Mr. J. Worsdell when Locomotive Superintendent of that line. Cast with the cylinder is a valve chest, shown in section in Fig. 81 by H. At each end of this chest is a cylindrical portion L L. These cylinders are bored out, and into them are forced by hydraulic pressure other cylinders or barrels of specially hard cast iron, bored and turned inside and out. In these barrels are cut ports M M, as shown in the cross section, which establish communication between the insides of the valve cylinders through chamber C, and thence to the cylinder ports P.

In the valve cylinders move the two pistons N N, secured on

¹ It is very usual to speak of the valves and valve gear of an engine taken as a whole as "the system of steam distribution," or, more shortly, "the distributing system."

the valve spindle by a collar and nut. The pistons are provided with packing rings. Steam is admitted from the boiler to each end of the valve chest, and the pressure only acts to push the two pistons together. They are therefore balanced and can be moved backwards and forwards each in its respective cylinder without any resistance but that of the friction of the packing rings and the stuffing box for the valve spindle. Into the central chamber opens the exhaust pipe, which either carries the steam

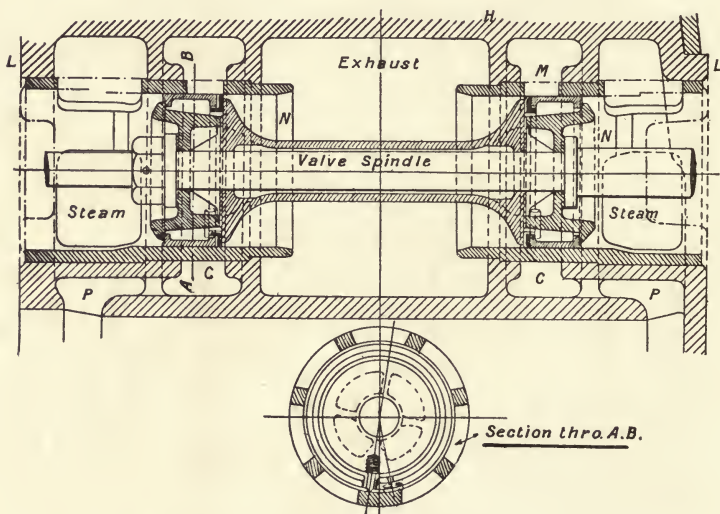

FIG. 81.—Smith's piston valve.

to the blast pipe or into the valve chest of the low pressure cylinder, according as the engine is not or is compound. The action is precisely that of a slide valve, the lap being obtained by widening the packing rings as shown.

The objections to the piston valve are, first, that it takes up a great deal of room; secondly, the ports must be carefully made in such a way that a packing ring can get into them. This is easy enough so long as this ring remains unbroken, but rings will break, and if a portion sticks in a port, then disaster is sure to follow. Thirdly, the pressure of the steam acting on the rings

when they are over the ports may cause them to collapse at each stroke, when serious leakage will occur. Fourthly, when water accumulates in the cylinders, as, say, when priming takes place, in a slide valve engine, the valve lifts off its seat when the piston strikes the water at the end of the stroke and no harm is done ; but the water cannot escape when a piston valve is used, and a spring loaded relief valve must be fitted at each end of each cylinder. Fifthly, when steam is shut off with a slide valve engine the pistons will act as a pump and draw steam out of the steam pipe and so make a vacuum, but compression takes place at each end of the stroke and lifts the valve off its seat, and air enters and restores the equilibrium. This is the reason why the slide valve of some engines may be heard "clattering" as a locomotive runs with steam off alongside a platform. The piston valve cannot do this, and the result is that when steam is shut off the pistons run against the full pressure of the atmosphere and resist the movement of the train. To avoid this, a special valve has to be used which prevents the setting up of a vacuum. From all this it will be seen that, excellent and indeed essential as the piston valve is, its use is, as has been said above, not unattended with difficulties.

CHAPTER XXXV

THE INDICATOR

THIS treatise would be incomplete if it did not contain a setting forth of some of the arguments for and against the compound system, which are urged with as much vehemence to-day as they were at any other period in the history of the locomotive.

It is necessary here to say something about the Indicator, an instrument which does for the engineer very much what the stethoscope does for the physician. For reasons already stated, much in this book is intended for the use of the non-technical reader. The following short description comes under this head.

The pressure of the steam continually alters in the cylinder as the piston moves. In order to ascertain what these changes of pressure are, the indicator is fitted to each end of the cylinder. The instrument consists of a very carefully finished cylinder containing a piston with an area usually of precisely half a square inch. On the top of this piston is fitted a spring holding it down. The piston rod is jointed to one arm of a very light parallel motion. The end of this arm carries a blunt-pointed German silver pin or style, which can be swung into contact with a strip of metallic paper rolled round a cylinder. This cylinder can be caused to rotate through about seven-eighths of a circle by a cord secured at one end to the paper cylinder, at the other to a lever connected with the cross head of the engine. Steam from the cylinder gets access through a stop-cock to the cylinder of the indicator. The piston of the indicator will rise and fall with the pressure in the engine cylinder, and the paper roll will rock backwards and forwards. If now the style be pressed lightly against the metallic paper on the roller, a diagram will be drawn which represents all the pressures in the engine

cylinder during one revolution of the crank axle. Not only this, but it will tell precisely at what part of the stroke each pressure was exerted, and it enables the performance of the valve gear to be examined. It tells in a word just what is going on inside the cylinder. Furthermore, by drawing ordinates across it at equal

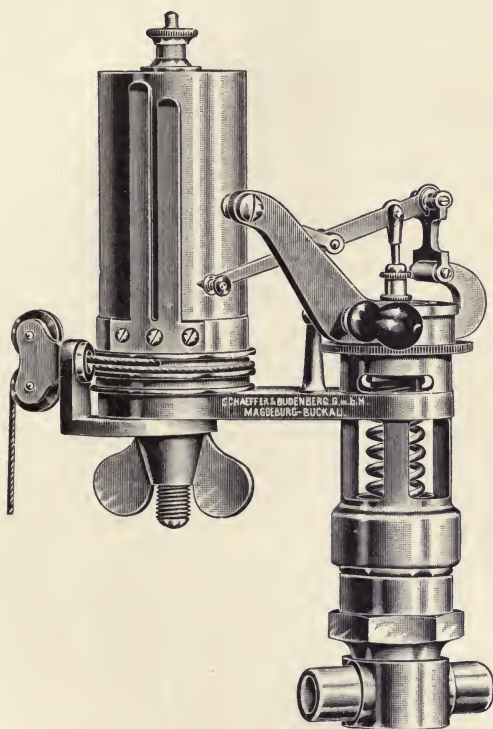

FIG. 82.—Thompson indicator with open spring.

distances and measuring the length of these on a scale with which the indicator spring has been calibrated, we get the average pressure throughout a stroke, and thence by a very simple calculation we arrive at the horse power. Examples of diagrams will be given presently.

Fig. 82 illustrates a modern indicator of the highest class

made by Messrs. Schaffer and Budenberg. When the spring is heated it is weakened, and therefore is no longer accurate. To avoid this the spring instead of being put inside the cylinder is put outside it. All the details are very clearly shown. The piston is of steel, ground to fit steamtight and yet to move without friction. Its range of motion does not exceed half an inch. There are many other types of indicator equally good, but the differences are in the main in detail, the objects had in view being the reduction of weight in the primary parts, convenience in handling, diminution of friction, and strength. There are various treatises on the indicator to which the student is referred for further information.

Now, the pressure of any given weight of any gas whatever varies with its volume. If we halve the volume we double the pressure. If we double the volume we halve the pressure, and so on. This is known as Marriotte's law, and is written $P V = a \text{ constant}$. That is to say, the pressure and the volume of any given weight of gas, say 1 lb., multiplied together, always come to the same amount. It follows from all this that when the indicator tells us what the pressure is at any point in the stroke of the piston, as we know the volume occupied by the steam, we ought to be able to tell precisely what weight of steam has been admitted to the cylinder. This holds true of a gas. It does not hold true of saturated steam, which is not a gas, but, as the reader will remember, a vapour in a state of unstable equilibrium. We can, by weighing the quantity of water pumped into a boiler in any fixed period, as, say, an hour, ascertain precisely what weight of steam is supplied to the engine. If nothing happened to this steam, the $P V = C$ law would apply. In practice, however, this is not the case. The pressure is always less than it ought to be; in other words, the indicator does not account for all the water pumped into the boiler. There are various sources of loss. Thus the slide valves or the piston may leak; or part of the feed water was not evaporated at all, but came over as priming. But the principal loss is due to condensation, and that condensation is in its turn due to the varying temperatures inside the cylinder. The inner surface of it is

first heated up to, say, 380° F., which is approximately the temperature of 200 lbs. steam—185 lbs. safety-valve load—when the admission port opens. Then it falls gradually as the pressure falls during expansion, and after the exhaust port has opened the temperature of the vapour remaining in the cylinder is little above 212° F. It will be seen, therefore, that the insides of the cylinder covers and the two piston faces are submitted to a range of temperature of $380^{\circ} - 212^{\circ} = 168^{\circ}$ F. It would be impossible to go here into the intricate theory of heat exchanges in the cylinder walls, as worked out by many English, French, and Belgian engineers. It is enough to say that “initial condensation”—that is to say, the condensation of the first steam that enters the cylinder and parts with its heat to warm up the cylinder and piston at the commencement of each stroke—has long been recognised as a source of loss. As much as 30 per cent. of all the steam supplied to a cylinder may be turned into water in it and do no work, representing a waste of 30 per cent. of the coal burned.

Condensation is also caused by radiation from the outside and conduction. The cylinder is cooled down by the air through which it passes. Heat is conducted through its walls to the side frames, and so on. The student of thermodynamics knows also that liquefaction takes place because part of the heat of the steam is converted into work. The first and most obvious remedy is to keep the cylinder hot; the second is based on a theory which now claims explanation.

In a general way it may be said that the weight of steam condensed in a given time by a given metallic surface varies chiefly as the difference in temperature. If, for example, 30 per cent. represented the condensation when the limits of temperature were 168° F., then 15 per cent. would be liquefied if the limits were 84° F., and so on. It is on this fact that the whole theory—which must not be confounded with practice—of the compound engine is based. It will be readily understood that if the pressure in a cylinder is not permitted to drop too far the condensation ought to be reduced. We have seen that the range may be 168° in a single cylinder, but in a compound engine the range in the

first cylinder might be only 52° , the pressure falling from 200 lbs. to 100 lbs.; while in the low pressure or second cylinder the range would be 106° , answering to 100 lbs. pressure and atmospheric pressure. The range of temperature in any one cylinder being lowered in a very obvious way, it is claimed that condensation is greatly reduced.

It may be safely said that the soundness of this theory has never been universally accepted. In the first place it is clear that although the range of temperature in any one cylinder is diminished, yet that the total weight of metal to be heated and cooled at each stroke—or, in other words, the condensing surface in the engine—is much increased. Again, in practice, it is found that the percentage liquefied is about the same in a compound as it is in a simple engine. Into the general reasons why the compound engine is more economical than the simple or non-compound engine it would be impossible to go here. We are dealing with locomotives, not with engines in general, and the compound locomotive will be more economical than the simple engine almost entirely because the cylinder capacity is augmented, while the objections already explained to cutting off early in a single large cylinder are avoided. Thus a compound locomotive properly designed will not under any circumstances “go blind.” Furthermore, even at low velocities, the steam is worked expansively of necessity. The driver cannot help himself. Now locomotives as a rule run slowly only when pulling heavy trains, and when running slowly, if they are put into full gear forward, the steam leaves the cylinder at a very high pressure, and with much work still in it. Any reader who has stood beside a steep incline and heard a locomotive pulling a train up it will realise this. The tremendous noise of the exhaust tells its own story; a compound engine pulling the same load up the same incline would be comparatively silent. When, however, the speed is high the conditions are altered. Automatic expansion then takes place. The steam cannot follow up the piston fast enough through the ports. The diagrams given here tell the whole story.

As it is essential that the arguments should be fully understood

a certain amount of repetition is necessary. What expansion means has already been clearly explained in Chapter XXIX. Those who have read with care what has been said about lap and lead and the link motion will remember that one distinctive feature of all valve gears worked by a link or its equivalent is that by shifting the link we can shorten the

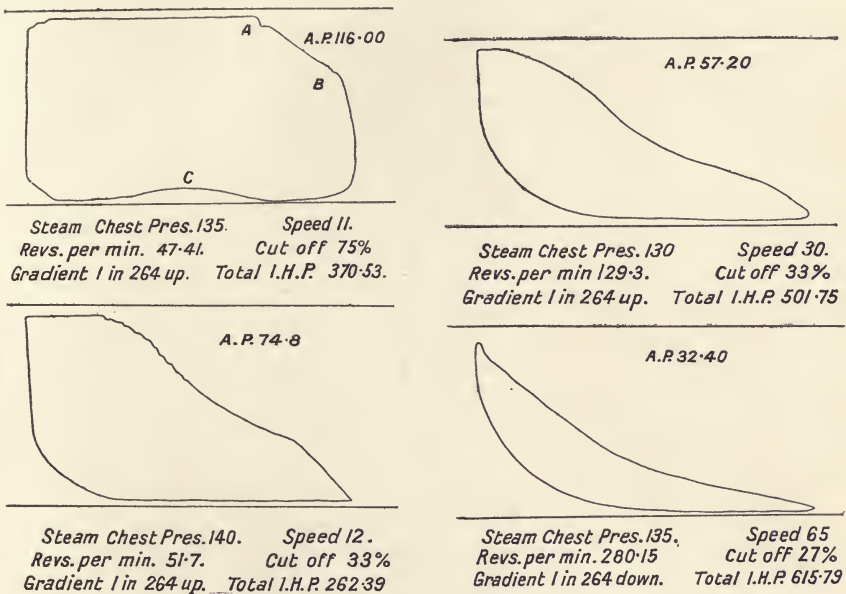

FIG. 83.

stroke of the valve, and therefore open less and less of the steam port as the point of cut-off becomes earlier. The result is wire drawing. The steam has to get in through so small an opening that it cannot follow up the piston moving at a high velocity, and the pressure rapidly falls throughout the stroke, indeed it is found that this takes place even if the valve motion is kept in full gear as the speed of the train augments. The result is that, whether the driver likes it or not, the steam will be expanded automatically. As an example of this, four diagrams

are given, Fig. 83, taken from an engine working a fast passenger train. The first was taken just as the train started, in full gear. The steam was admitted over three-fourths of the stroke; the valve closed at A; the exhaust port opened at B; the curve at C in the exhaust line was due to the opening of the exhaust in the other cylinder and a consequent rise in the blast-pipe pressure. In the second diagram the speed had risen to twelve miles an hour; the engine had been linked up and the cut-off took place at one-third of the stroke. Compare now this diagram with No. 3. The position of the link has not been changed, but the speed has risen to thirty miles an hour, and we find pronounced evidence of wire drawing. The whole diagram is much leaner than No. 2. The precise point where the steam port closed can no longer be defined. In No. 4 all this becomes still more strongly marked. It is true that the link has been raised a little, but the speed is now sixty-five miles an hour, and the steam is quite unable to follow up the piston. It is particularly to be noted that the terminal pressure has now fallen practically to that of the atmosphere. There is no more work left in the steam; it has to be pushed out by the piston.

Now the great utility of compounding, as far as a locomotive is concerned, lies in sending no steam up the chimney with available work in it. No compound engine could do this more effectively than it is done in No. 4. But going to No. 1 we see that the steam escaped from the cylinder with a pressure of at least 100 lbs., and this was unavoidable under the conditions. If, now, a low pressure cylinder had been added, in which this otherwise wasted steam could have been utilised, a considerable economy would have resulted. Here we have in a nut-shell the essence of the whole problem. When the speeds are high the exhaust pressure must be low; when the speeds are low the exhaust pressure may be very high, unless the engine is compound. The slow-speed goods or mineral engine may be made compound with great advantage, while nothing whatever might be gained by compounding the fast passenger engine.

The position then is this: When the speeds are low and the loads are heavy the compound engine has beyond doubt a

possible advantage, much depending, however, on the way in which the engine is handled. At high speeds the compound engine is worse than the simple engine. It cannot take any more work out of the steam, the terminal pressures being about the same. The back pressure resistance is augmented because the piston area is greater; and the engine is heavier, more expensive to make and to maintain. In this country the compound engine has not achieved much popularity, because the working conditions are not favourable. Abroad, where the roads are more trying, the speeds low, and the loads heavier, the system does excellent service and enjoys favour. But, as has been already said, it does not appear that the loss by condensation in the cylinders is sensibly reduced, and it is a suggestive fact that it is claimed that superheating does more good with compound than with simple engines, which could not well be the case if cylinder condensation did not remain an important factor.

Proofs exist in abundance that the economy of the compound system only becomes apparent when the speeds are so low that the terminal pressures in the cylinders are high. That is to say, it is not of use in passenger locomotives. A crucial experiment was carried out some months ago by Mr. Ivatt on the Great Northern Railway. He communicated the facts last year to the Institution of Mechanical Engineers. The table on page 258 is reproduced from the Transactions of the Institution. It is full of valuable information. It will be understood that three modern engines of great power were used. No. 1300 is a four-cylinder compound, No. 292 is a four-cylinder locomotive, which can be worked either compound or simple, and No. 294 is a two-cylinder simple engine. They are all of the 4—4—2 type, with almost identical boilers, the heating surface being approximately 2,350 square feet, the grate area in each being 31 square feet.

The trials from London to Doncaster were so arranged that each driver and fireman, of the three sets of men selected, should run each engine for three weeks with the same group of trains (mostly express) in regular rotation. By this means it was intended that each driver should make the same number of trips with each engine on each train, thereby eliminating the personal

equation and equalizing all conditions as far as possible. The drivers and firemen took great interest in the trials, and, as an

RESULTS OF TRIALS.

	Engine No. 1300. 4-cylinder Compound.	Engine No. 292. 4-cylinder Combined.	Engine No. 294. 2-cylinder Simple.
Miles run, engine	11,286	11,670	11,673
„ train	11,045	11,415	11,415
Speed, average, miles per hour .	49·02	49·9	49·58
Weight of train, average, tons .	229·98	238·03	234·29
TON-MILES :—			
Total train	2,540,130	2,717,112·5	2,674,420
Including engine and tender .	3,803,030	3,993,812	3,949,110
Per hour „ „	16,759	17,337	17,030
COAL USED :—			
Per engine-mile . . . lbs.	44·86	43·02	44·31
Per train-mile . . . „	45·84	43·98	45·31
Per ton-mile . . . „	0·133	0·126	0·131
OIL USED :—			
Per 100 engine-miles . pints	7·34	7·18	6·22
Per 100 ton-miles . . „	0·022	0·021	0·0184
COSTS :—			
Coal—			
Per engine-mile . . . pence	2·4	2·3	2·37
Per ton-mile . . . „	0·0071	0·0067	0·007
Oil—			
Per engine-mile . . . „	0·165	0·16	0·14
Per ton-mile . . . „	0·00049	0·00047	0·00041
Repairs—			
Per engine-mile . . . „	0·56	0·45	0·37
Per ton-mile . . . „	0·0017	0·0013	0·001
Total—			
Per engine-mile . . . „	3·125	2·91	2·88
Per ton-mile . . . „	0·0092	0·0085	0·0085

additional stimulant for them to make each engine show to the best advantage, prizes were arranged *based on the aggregate performance of the men*, and not on that of any engine. The men

ran each of the engines for one week prior to commencing each three weeks' trial, in order to get thoroughly familiar with them.

The engines were put into the same condition of repair before the trials, and were treated in the same way throughout, and were supplied with the same quality of coal, namely, Yorkshire from the Barnsley bed. Careful account was taken of coal and oil used, time lost or made up, state of weather, weight and composition of trains, and cost of running repairs. An inspector rode with each engine during the trials.

All three engines drew all the trains in turn. The fastest was timed at 51·28 miles an hour, and the other two at 47·16 and 46·11 respectively. The average speed was 48·15 miles an hour. It will be seen that the combined engine had rather the smallest coal consumption per train-mile, while for repairs the simple engine came out best. The most telling fact is, however, that the total cost per ton-mile of the compound engine was greater than that of either of the other two.

It has been explained in a preceding page that an intercepting valve is generally used to reduce the pressure where steam has to be admitted directly to the low pressure cylinder of a compound engine, as at starting—to reduce the pressure to a limit which shall be safe on the large piston. Mr. Ivatt has taken advantage of the small size of each piston, when four are used, to dispense with the reducing valve in the combined engine No. 292. The low pressure inside cylinders have one valve chest in common, and are 16 inches diameter by 26 inches stroke. The two high pressure cylinders are outside, 13 inches diameter by 20 inches stroke. A change valve is provided, which, in one position, allows full boiler pressure steam to enter the low pressure valve chest as well as the two high pressure valve chests outside, and at the same time puts the high pressure exhaust in communication with the blast pipe. The low pressure exhaust of course always goes up the blast pipe. When the valve is in the other position (compound) it cuts the live steam off the low pressure chest and changes the exhaust from the high pressure cylinders to the low pressure steam chest. When the valve

stands in the "simple" position the engine works as a four-cylinder simple, and the driver notches up both reversing gears accordingly. All the parts are strong enough to stand this, and that is the way the engine would run when working a coal train or a slow heavy goods. In working a passenger train—say out of King's Cross—the engine starts as a four-cylinder simple, and, if the train is heavy, keeps like that until the speed gets up to, say, 40 miles an hour somewhere about Finsbury Park. Then the driver shifts the change valve and makes her into a compound, puts the low pressure reversing lever nearly full over, and does his notching up with the high pressure reversing lever. The result is, of course, a very useful all-round engine.

Various systems of superheating have been described. According to the late Professor J. Macquorn Rankine, if steam is superheated about 40° F. it acquires, as has been already stated, the properties of a gas. In other words, it loses some of its instability. But much more than this is required to do any good, and steam is superheated in locomotives by from 200° to over 400° . Thus steam of 380° acquires a temperature of 580° to 700° . Unfortunately, it is not possible to secure more than an approximation to regularity of temperature. Care is taken as far as possible to make it certain that no condensation will take place in the cylinders. The steam then behaves as a gas and the indicator will, in theory at least, account for all the water put into the boiler.

It does not require much knowledge of machinery to see that surfaces heated nearly red hot—iron begins to glow in the dark at about 800° —are liable to work on each other with much friction. But the pressure holding two surfaces together is an important factor. It is for this among other reasons that superheated steam cannot, as already stated, be worked in engines with unrelieved or unbalanced slide valves; piston valves are essential. Again, no vegetable oil can be used as a lubricant. It would be carbonised at once, and the statement is true, though to a less extent, of animal oils. We are driven, therefore, to the mineral heavy oils, and these have now been brought to very great perfection as lubricants for engines using superheated

steam. It is indeed doubtful if very hot steam could have been used at all without the aid of mineral oil.

An energetic controversy has proceeded for some time among Continental engineers as to the relative merits of compounding and superheating. On the one side it is held that the loss by internal condensation in the compound engine is very small, and that the great increase in cylinder capacity secured by it is of immense advantage in that the tractive power of the engine can be augmented to anything desired within the limits of adhesion, simply by using the intercepting valve and working non-compound when necessary. The speed will, of course, be slow and the boiler able to supply the demand. It may be taken that the total capacity of the cylinders of a compound engine is not less than one half greater than that of a simple engine. If then the engine is worked non-compound it can utilize three pairs of driving wheels, while a similar simple engine could only utilize two pairs. The argument must be taken for what it is worth. Back pressure in the high pressure cylinder has to be considered, and the admission of steam of full boiler pressure to the low pressure cylinder does not seem to be good practice. The most that need be conceded is that compound locomotives properly handled start trains very well, and are excellent hill climbers. When four cylinders are used it is quite easy to carry out compounding, difficulties which exist with the two-cylinder compound being avoided.

On the other hand advocates of superheating like Herr Garbe, already quoted, maintain that, the steam being more efficient, a larger cylinder in proportion to the boiler can be used without risk of "running the engine out of breath," and that in this way great tractive effort is secured, while the economy attained is greater than anything that can be had from compounding. Furthermore, superheating is of use at all times and under all conditions, whether the speed is high or low, whether the engine is climbing a bank or running on a level, and this in contradistinction to the compound system, which is of use only at low velocities when a "fat" diagram is given by the working conditions. It is worth a passing notice that both parties claim a saving of about 12 per cent. as compared with ordinary "simple"

engines on the same duty. Superheating and compounding have been tried in the same engine, but no one claims that a saving of 24 per cent. is effected. Indeed, so far as can be learned, the duplicate system is very little if at all better than either of the two alone. An advantage is, however, secured, though a small one, by placing the intermediate receiver, which is in point of fact the pipe uniting the high and low pressure cylinders, in the smoke-box, by which means the steam is dried on its way to the low pressure cylinder.

It is proper to observe here that the arguments used on both sides extend far beyond what has been just stated. Thermodynamics have been called in by both parties, and it need scarcely be added that mathematical disquisitions abound. These possess an academical interest only. The broad facts are as stated, that compounding may or may not be productive of a saving in the consumption of fuel, according to the conditions under which the engine is working. Superheating will certainly give a saving in fuel; but an efficient superheater is a very heavy and very expensive addition to an engine, and its life cannot be long. Let us suppose that in three years a superheater costing £400 is worn out. During that time the engine will have run 60,000 miles and burned 10,000 tons of coal. If we take the saving at 10 per cent., that means 1,000 tons of coal. With coal at 10s. a ton we have then on the one side a capital outlay of £400 and on the other a saving of £500 in coal. Whether superheating should be used or not is obviously determined by the price of coal as a principal, though of course not the only, factor. The extra cost of a compound as compared with a simple engine is so small that it need not be taken into account, particularly when it is remembered that engines practically never wear out.

Summing up, it may be said that so far all the indications are that simple engines will continue to be built in by far the greater number for the more moderate powers, and that compounding and superheating will both be used according to the proclivities of locomotive superintendents and the conditions under which the work of their locomotives is performed.

CHAPTER XXXVI

TENDERS

THE tender requires little description. The framing is usually in all respects identical with that of the engine. In certain cases, indeed, the tender-wheels axles and axle boxes are interchangeable with the small or carrying wheels of the locomotive. The after part of a tender is a water tank of thin plate steel, which is strengthened by vertical cross "wash" plates which do not of course reach to the bottom. They are intended to prevent the surging of the water in the tank when the train is in motion. The first effect of starting would, for example, be to carry all the water to the back of the tender for the moment, and when stopping it would all rush forward. In front of the tank is the coal bunker. Much diversity of design is to be found in tenders. A long, low tender carried on six wheels may be made very handsome, but its capacity is limited. It possesses the great advantage that, should the fireman have to go back along the top to bring coal forward, his head will not strike a bridge. Fatal accidents have occurred in this way. As a rule the springs are in the present day always put outside the frames. At one time they were often placed inside, or the frames were made double and the springs put between them. The objection is that a spring may be broken without the knowledge of the driver, or any one else, and that to replace a spring, or an axle box, the whole tender having to be lifted, is by no means easy. The dimensions of the tender are partially settled by that of the engine. A normal tender carries 4,000 gallons of water and about five tons of coal. The water occupies 640 cubic feet and weighs $17\frac{3}{4}$ tons. If the engine uses 40 gallons to the mile, then 4,000 gallons will suffice for 100 miles. Coal varies in density.

On a tender a ton will occupy about 45 cubic feet. The bunker capacity for five tons will therefore be about 225 cubic feet.

The breadth of a tender is limited, as is that of all rolling stock on British railways, by the width of tunnels and the position of station platforms. The length again is limited in another way, namely, by the diameter of turntables. The wheel base of the engine and tender together must not exceed about 50 feet. It is true that at some important termini the diameter of turntables has been augmented. But, as a rule, when more water and coal have to be carried than the quantities stated the tender is made high. Examples of this may be seen in the very large tenders in use for the express traffic of the London and South Western Railway, which are carried each on two four-wheeled bogies. In the United States enormous tenders are required by the monster engines employed in the heavy freight traffic. As much as ten tons of coal are carried in some cases.

It is clear that to haul about the country a forty-ton tender is not an economical thing to do. Furthermore, we have seen that a run of 100 miles is the limiting distance that can be got out of 4,000 gallons of water. But runs of considerably over twice this distance are now common. To accomplish these, the tenders pick up water as they run. This method of replenishing tenders was invented by Mr. Ramsbottom in 1857, and first used on the London and North Western Railway. Various other railways use the Ramsbottom system, modifications being introduced, but merely in details. The system has been more fully carried out on the London and North Western Railway perhaps than on any other. It has certainly been in use for some years, and attention may therefore be confined to that line.

A number of narrow troughs have been laid down between the rails at convenient places along the main lines, which by an automatic arrangement are kept continually filled with water, and from these water is picked up by the engines as they pass over by means of a scoop attached to the tender. By this arrangement a train is enabled to run from one end of the line to the other without a stop, as was done on Sunday, September 8th,

1895, when a train left Euston at 8.45 a.m. and ran right to Carlisle without a stop.

Another advantage is that a smaller tender can be used than would otherwise be required, and consequently less dead weight. The troughs and "pick-up" were, as has been said, first introduced by Mr. Ramsbottom in 1857, and since then troughs have

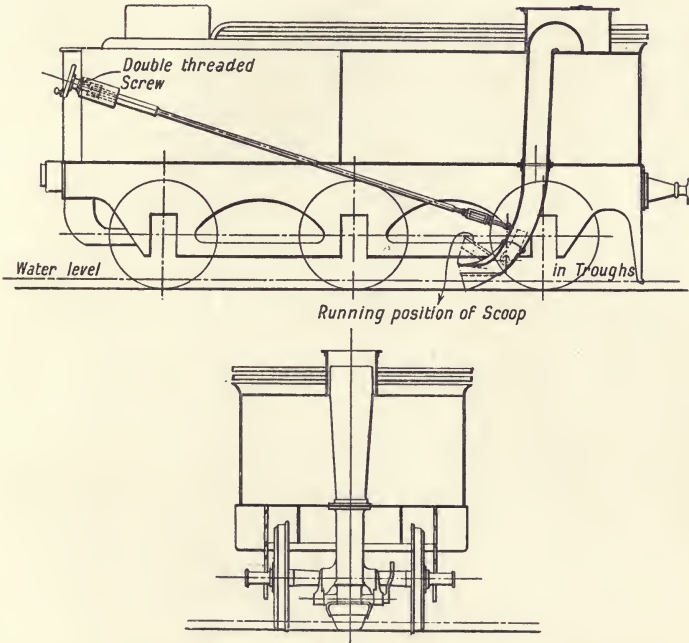

FIG. 84.—Pick-up apparatus, London and North Western Railway.

been laid down at thirteen different places on the main lines. The troughs (which are 18 inches wide by 6 inches deep) are usually 560 yards long, and at each end, for a length of 180 feet, they are gradually reduced in depth, the bottom of the trough running out at an inclination of 1 in 360, both ends being open. The rails also dip down at the same inclination as the troughs, so that by this arrangement an engine passing over the line will, on arriving at either of the gradients, be gradually lowered until the

mouth of its dip pipe is fairly within the trough, but not in contact with the bottom. On approaching the other end of the trough, the reverse action takes place, the engine ascends the gradient and gradually withdraws the dip pipe, if this has not previously been done by the driver when the tanks are filled.

The pick-up apparatus, fully illustrated by the engraving, Fig. 84, is fixed to the under side of the tender, and consists of a dip pipe, the upper end of which is secured to the bottom of the tank. To its lower end is attached a scoop, pivoted at its sides to the dip pipe, its mouth being curved forward so as to meet the water when lowered into the troughs between the rails.

On the end of the pivot on which the scoop turns a lever is fixed, which is connected by a rod to the engine footplate. The normal position of the scoop is horizontal, with its mouth clear of the troughs and ballast, and when it is necessary to pick up water, on approaching the troughs, the driver, by pulling the rod mentioned above, turns the scoop so that its mouth is lowered below the level of the water in the troughs, which it scoops up and delivers into the tender tank. As soon as there is sufficient water in the tank, the driver pushes back the rod to its former position, lifting the mouth of the scoop out of the water. Inside the tender tank, and immediately above the dip pipe, another pipe is fixed, which forms a continuation of the dip pipe. The top of this pipe is continued above the highest water level, and is then bent or curved downwards so that the water after passing up the dip pipe is directed into the tank. The principle of the pick-up consists of taking advantage of the height to which water rises in a tube when a given velocity is imparted to it in entering the bottom of the tube, the converse operation being carried out in this case—the water being stationary and the tube moving through it. On the London and North Western Railway the scoop is raised and lowered by a double-threaded screw on the tender. On other lines a piston in a cylinder worked by compressed air from the continuous brake is employed. Others use a small steam cylinder.

The work of refilling a tender tank is done at a pace which is not easy to realise. Taking the length of the trough at 1,680 feet

and the speed of the train 60 miles an hour, or 88 feet per second, the length of the trough will be travelled in 20 seconds. In this short time ten or twelve tons of water will be lifted into the tender. Indeed, unless the fireman is on the alert to raise the scoop, the whole tender and footplate may be flooded in a cataract of water. This took place once, and the firing shovel was washed off the footplate. How steam was kept up with genuine hand-firing until a station was reached where a shovel could be got is not recorded. The following list of the sixteen troughs on the London and North Western Railway will probably interest the reader.

LIST OF WATER TROUGHS ON THE LONDON AND NORTH
WESTERN RAILWAY.

- Between Pinner and Bushey.
 „ Wolverton and Castlethorpe.
 „ Rugby and Brinklow.
 „ Tamworth and Lichfield.
 „ Whitmore and Madeley.
 „ Preston Brook and Moore.
 „ Brock and Garstang.
 „ Hestbank and Bolton-le-Sands.
 „ Low Gill and Tebay.
 „ Waverton and Chester.
 „ Connah's Quay and Flint.
 „ Prestatyn and Rhyl.
 „ Llanfairfechan and Aber.
 „ Diggle and Marsden.
 „ Eccles and Weaste.
 „ Halebank and Speke.

It is by no means necessary that the speed of the train should be 60 miles an hour. Indeed, much better results are got at lower speeds, the water being less splashed about. The water will rise to any height, provided the scoop moves at a velocity somewhat in excess of eight times the square root of the height. Roughly speaking, the water has to be lifted about 9 feet; the

square root of 9 is 3, and $3 \times 8 = 24$ feet per second as the velocity which the water would attain if it fell 9 feet. Now 24 feet per second is only 16·3 miles an hour; at 60 miles an hour the water would be lifted over 120 feet, and is, indeed, projected into the tanks with almost as much violence as though it fell from that height. The adoption of the trough system, excellent as it is, has been very slow. There are drawbacks to it. A very large number of trains—even fast expresses—do not run more than 100 miles without a stop. The troughs are expensive to lay down, and the line must be dead level and quite straight where they are placed. But the strongest objection to them is that in winter they must be kept clear of ice by platelayers who drag a small plough along the trough. The under bodies of the coach at the leading end of the train are splashed. The water freezes and the vacuum pipes of the brake are coated with ice, become stiff, and disconnect, stopping the train. On other lines the brake gear is sometimes held fast by ice and is inoperative. But we seldom have frosts sufficiently severe to give much trouble, and for long runs the scoop is of course indispensable.

As a considerable saving of fuel may be attained by heating the feed water, and the steaming power of the boiler is for some ill-understood reason augmented more than theory denotes, a pipe is always carried from the boiler to the tender. Through this steam can be passed into the tender tank when the engine is standing in a station or terminus, instead of being blown off to waste through the safety valves. But, as has been shown, the temperature at which an injector will feed is comparatively low, and the heating of the water must not be pushed too far; besides, steam is not available for heating the water when the engine is running.

More than twenty years ago Mr. Stroudley carried a part of the exhaust steam back to the tender, and so raised the temperature of the feed water. The whole of the steam was thus treated in the tank engines working the Metropolitan Railway at a much earlier date, not to heat the feed, indeed, but prevent the discharge of steam into the tunnel. There are objections to the putting of exhaust steam direct into the water. It is apt to carry

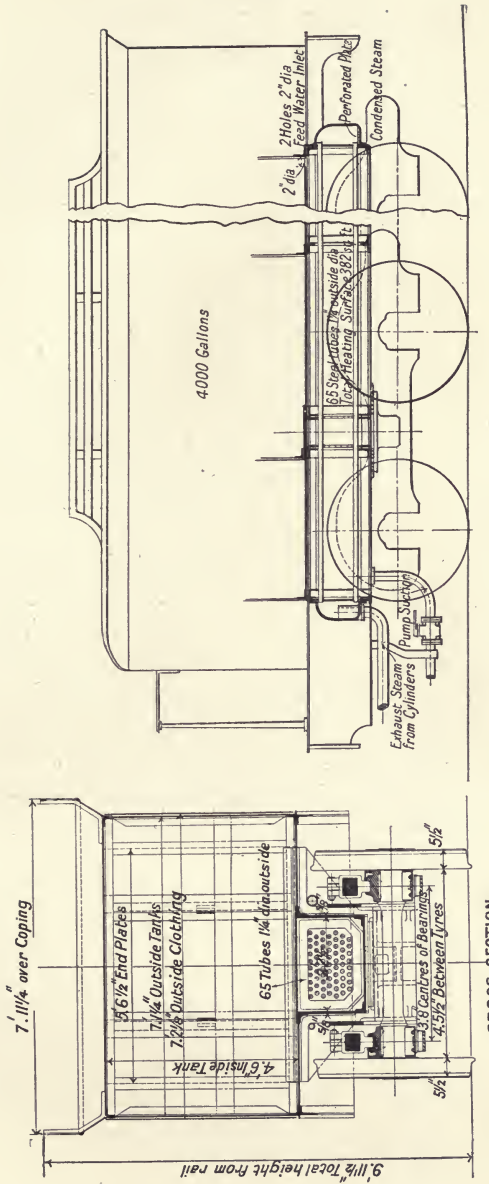

FIG. 85.—Feed water heater, London and South Western Railway.

grease with it, which is bad for a boiler and may set up priming. For some time past Mr. Drummond has had in use with great success the water-heating arrangement shown in Fig. 85. Under the main tank is a subsidiary tank, through which the water must pass on its way to the feed pump or injector. In this subsidiary tank are sixty-four tubes, through which a portion of the exhaust steam is passed. It is condensed, and the resulting water drains away to the ground. The feed water is considerably raised in temperature. The whole arrangement is very simple and inexpensive, and gives no trouble; the temperature of the water is, however, too high to permit the use of an injector, and a duplex donkey pump is employed to feed the boiler. The net saving in coal averages about 13 per cent., but the major advantage is no doubt found in the fact that the life of the fire-box is prolonged, and the actual steaming power of the boiler is augmented to a degree theoretically out of proportion to the rise in temperature of the feed.

The connection between the tender and the engine has been made the subject of a good deal of invention. Usually there is one centre drawbar and two auxiliary bars. They pull on india-rubber spring cushions fixed in a heavy frame under the footplate; the water is led from the tender to the injector through an india-rubber hose pipe at each side of the engine. The flow of water is controlled by two simple stop cocks, the handles of which are placed one at each side on the wings of the coal bunker, where they are under the fireman's hand.

CHAPTER XXXVII

TANK ENGINES

LOCOMOTIVE engines, however much alike in their general characteristics, are divided into two distinct classes, according as their supplies of coal and water are or are not carried in a separate vehicle. That is to say, we have tender engines and tank engines. The former are used for long distance and the latter for short distance work. Obviously the quantities of fuel and water needed on suburban lines are much less than those needed for long runs. Furthermore, the tank engine being much shorter than an engine and tender, valuable space is saved, and as the tank engine runs equally well backwards or forwards no turntables are needed, and a great saving in time is effected.

There are two varieties of tank engine; in one the water is carried in a saddle on top of the boiler, which holds 500 or 600 gallons. Locomotives of this kind are much used for shunting and yard work. They are usually small, and need not be considered here. On page 272 is given a photograph of a collision which took place at Bina, a station on the Great Indian Peninsula Railway, at night in February, 1907. A mail train ran into a shunting train; both drivers and one fireman were killed. The photograph is interesting because it shows very clearly the extraordinary way in which railway vehicles of all kinds tend to mount over each other in collisions. The saddle tank of the shunting engine is very clearly seen.

The tank engines of importance are those which carry their water in rectangular tanks at each side of the boiler, and sometimes a third tank is placed under the footplate and coal bunker. They are, of course, all united by a tube or tubes. The tanks generally hold about 1,000 gallons. They are often double, that

is to say, the inner tank portion is fitted with an ornamental casing. Engines of this kind are largely used for working suburban traffic. They have gradually augmented in dimensions until some of them are exceedingly powerful, handsome engines. They have small driving wheels, often six-coupled, the great object in view being rapid acceleration, so that they can get away with their loads from stations very quickly. They are seldom



Collision at Bina, Great Indian Peninsula Railway.

required to run faster than thirty miles an hour. It has been proposed to construct tank engines with large driving wheels and to supply them with water by scoops in order to save the haulage of a tender, but the proposal came to nothing.

Tank engines in the present day are more often fitted with traversing leading or trailing axles than with bogies. At one period all large tank engines had bogies at either one end or the other. In the general details of the construction they conform closely to tender engines, except that, as has been said, they almost invariably have wheels under 6 feet in diameter.

The question of acceleration mentioned above is one of the utmost importance in working suburban and metropolitan traffic. To it is mainly due the substitution of electricity for steam in cases like the Liverpool and Southport line, where ventilation had nothing to do with the matter. Time saving in the case of suburban and metropolitan traffic is of the utmost importance. On the Great Eastern Railway Mr. Holden appears to have done all that can be done with steam. Travelling inspectors took a record of the average time occupied at a platform from stop to start. Over 30,000 observations were made. The average obtained was 27·5 seconds. To consider the question in all its bearings, its influence upon gradients, as determining when it is and is not economically right to flatten a gradient, and so on, would be impossible here, and indeed somewhat beyond the scope of this book. It is worth while, however, to give an accelerating formula used by railway men in the United States.

The resistance due to acceleration energy of retardation is equal to $70 (V_1^2 - V_2^2) \div D$, in which V_1 and V_2 represent the initial and the terminal velocities in miles per hour, and D equals the distance in feet travelled in accelerating or retarding the velocity.

The distance travelled in accelerating or retarding speeds from mile to mile is obtained by transposing the equation for resistance due to acceleration.

Feet distance travelled = $70 (V_1^2 - V_2^2) \div R$, where R equals the difference per ton between power of engine and resistance of train, as already explained. Whenever the difference per ton is positive, *i.e.*, when the drawbar pull is in excess of train resistance, the distance travelled, obtained by the formula, will represent distances travelled in acceleration, while, when it is negative, the distances will be those in retardation of velocity.¹

A word of explanation is desirable here to render the curious experiment illustrated by Figs. 86 and 87 intelligible. In every body, no matter what its shape is, there is a point called the centre

¹ For further information the reader is referred to a paper by Mr. A. K. Shurtleff, in the Bulletin of the American Railway Engineering and Maintenance of Way Association for November, 1907.

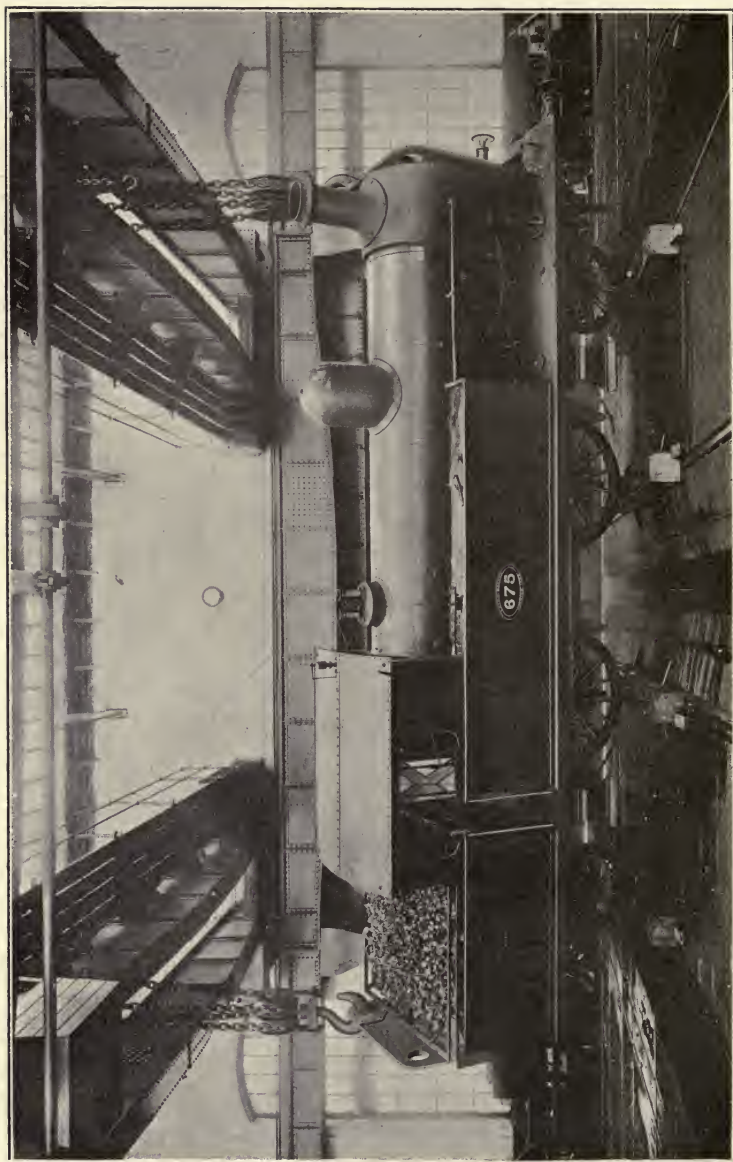

FIG. 86.—Finding the centre of gravity of a tank engine.

of gravity, such that if the body be suspended from this point it will remain in equilibrium indifferently in any position ; and if

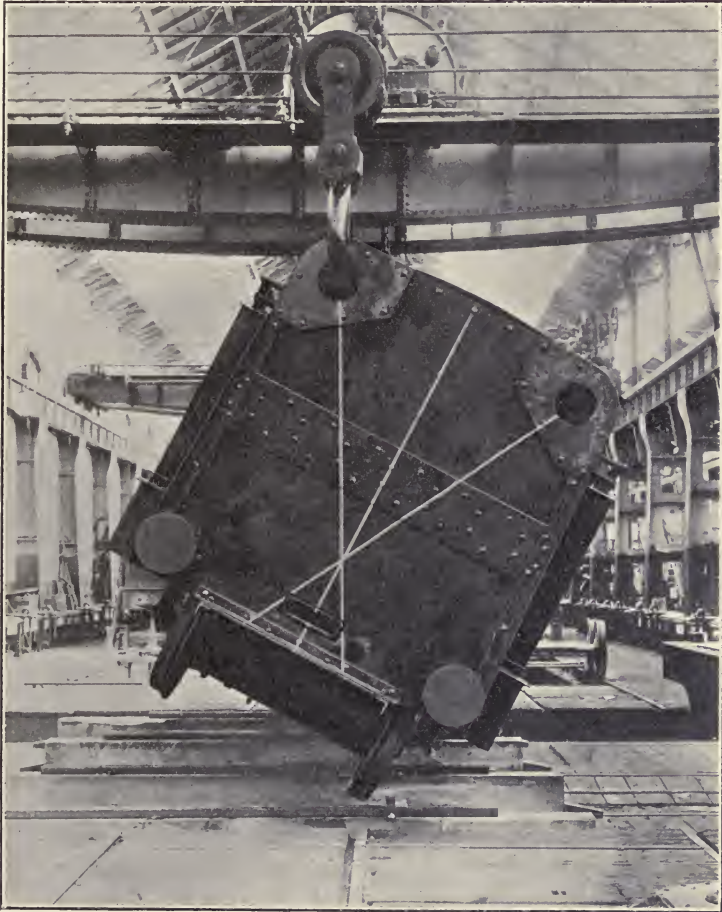

FIG. 87.—Finding the centre of gravity of a tank engine.

the body be suspended from any other point, then it will be in equilibrium when the centre of gravity is directly under the point of suspension, and any vertical line drawn from any other

point of suspension will pass through the centre of gravity. If, for example, an irregular figure is cut out in cardboard and freely suspended from any point, behind a plumb line, then a line can be drawn along the card with a pencil coincident with the string. Next let the card be freely suspended from any other point in it as before, and a second pencil line be drawn upon it coincident with the string. The second pencil line will intersect the first pencil line, and the point of intersection is the centre of gravity. And it matters nothing how often the operation is repeated, the pencil lines will all intersect in the same place.

As it is not always feasible to hang up heavy bodies to get their centre of gravity, recourse is had to calculation. The weights of different parts are taken, and their moments, that is to say their leverages round an assumed point, are taken, and in this way the centre of gravity is obtained. The influence of the position of this point on the behaviour of an engine on the road has already been fully considered in Section I.

In 1905 Mr. Aspinall made the experiment illustrated. He suspended one of his large radial tank engines, in working order, with coal and water, from the traversing crane in one of the Horwich shops of the Lancashire and Yorkshire Railway. Two points of suspension were selected. On the back of the tank are shown three vertical lines drawn by the aid of a plumb line. They intersect, it will be seen, and the point of intersection gives the vertical height of the centre of gravity above the rails. Calculations which were previously made gave the height as 4 feet 10 inches, and the actual experiment gave it as 4 feet $11\frac{7}{8}$ inches, a very close approximation. The great height of the modern big boiler engine deceives the eye. Thus an engine with a boiler standing 8 feet 11 inches above the rails will have a centre of gravity only 5 feet 6 inches above them.

The ordinary observer is apt to forget that little more than half the boiler barrel is filled with water, and that the upper half therefore contributes very little weight to the whole structure. These large engines run with very much greater smoothness than is possible with an engine whose centre of gravity is very low down, for reasons already set forth.

In the first section of this book the subject of derailment has been treated on general principles, and no reference has been made to the relative safety of the two types of engine, tender and tank, for it appeared that this question would be best postponed until the tank engine came up for consideration. This, then, seems the proper place to mention a discussion which took place some years ago between locomotive superintendents and Board of Trade inspectors. These gentlemen assumed that the tank engine must be more liable to derailment than a tender engine. Mr. Aspinall determined to ascertain from statistics whether this was or was not true, and he had information collected from the Board of Trade returns. These were in a sense private, and the author is indebted to Mr. Aspinall for permission to make the facts public here for the first time, in the shape of the following memorandum:—

MEMORANDUM *re* DERAILMENTS OF PASSENGER TANK ENGINES.

The diagram has been prepared for the purpose of illustrating the reports made by the various Board of Trade inspectors upon all classes of tank engines and all classes of tender engines which have been derailed during the twenty years ending December 31, 1904, as stated in the return made to both Houses of Parliament, entitled "Return of Cases of Derailment of Engines of Passenger Trains during the twenty years ending 31st December, 1904, divided into (1) Tank Engines, and (2) Tender Engines, showing in each case the date, place of accident and railway, and the class of engine"; signed by Sir Francis Hopwood, and dated Board of Trade, May 24, 1905. All the facts and figures are taken from the above official return.

This diagram, Figs. 88 and 89, is divided into nine parts, which are numbered 1 to 9.

Diagram No. 1.—This gives small diagrams showing how each type of tender engine reported upon is arranged so far as wheels are concerned, and what class of tender was hauled behind the engine.

Diagram No. 2 gives similar information with regard to the wheel arrangements of the several types of tank engines.

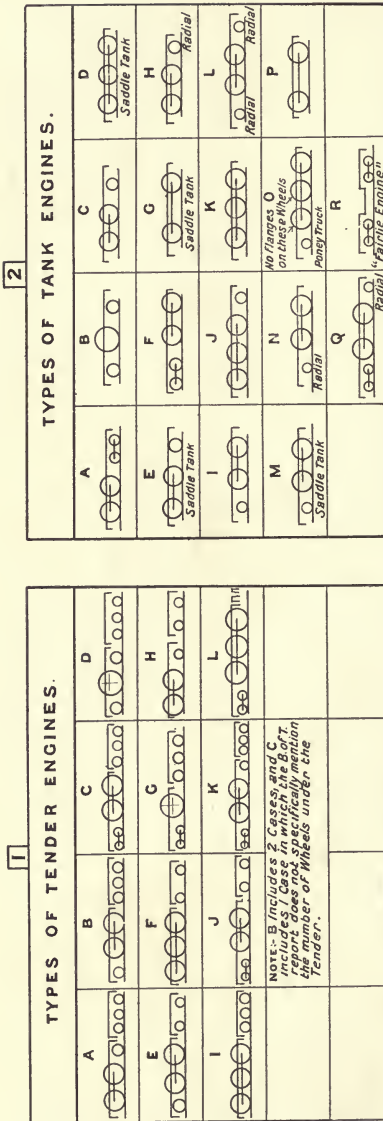

3

FLUCTUATION IN THE NUMBER OF DERAILMENTS EACH YEAR. TENDER ENGINES - - - - TANK ENGINES

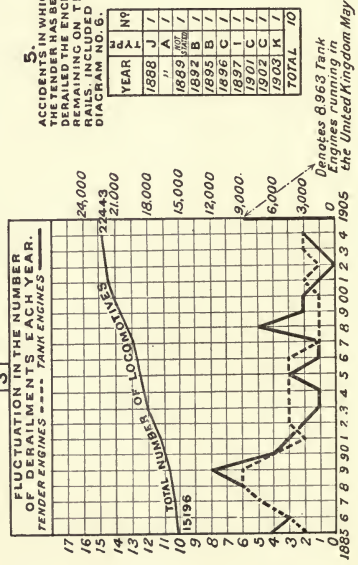

5.

ACCIDENTS IN WHICH THE TENDER HAS BEEN DERAILED THE ENGINE REMAINING ON THE RAILS. INCLUDED IN DIAGRAM NO. 6.

YEAR	3	4	1	9
1888	J	I	I	I
1889	J	I	I	I
1890	J	I	I	I
1891	J	I	I	I
1892	J	I	I	I
1893	J	I	I	I
1894	J	I	I	I
1895	J	I	I	I
1896	J	I	I	I
1897	J	I	I	I
1898	J	I	I	I
1899	J	I	I	I
1900	J	I	I	I
1901	J	I	I	I
1902	J	I	I	I
1903	J	I	I	I
1904	J	I	I	I
1905	J	I	I	I
TOTAL	10	10	10	10

6.

Denotes 8963 Tank Engines running in the United Kingdom May/1905.

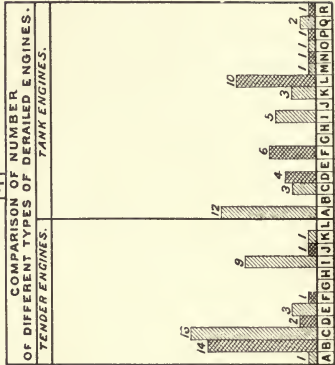

Fig. 88.—Derailments.

Diagram No. 3 shows by means of a black line that the number of locomotives which were possessed by the different railway companies had increased from 15,196 in the year 1885 to 22,443 in 1904; and it also shows the number of tender engines which were derailed in each year by means of a dotted line, and the number of tank engine derailments by means of a heavy line. For example, it will be observed from this diagram that there were two tender engines derailed in 1885 and four tank engines derailed in 1885, but only two of the latter in 1904. This diagram does not point to there being any greater tendency for a tank to become derailed than for a tender engine.

Diagram No. 4 is divided into two parts, and shows by the height of columns either lined or hatched the number of derailments of tender engines on the left-hand side, and of tank engines on the right-hand side, and enables the different classes to be picked out by reference to diagrams 1 and 2, where the letters "A," "B," "C," etc., are applied to each type of engine. For instance, with tender engines of class "C," with a leading bogie, sixteen are shown to have left the road by the column which stands over the letter "C"; in like manner, with tank engines twelve are shown to have left the road by the column over the letter "A." Those who are familiar with the very large amount of work done upon English railways by tender engines of class "C" and tank engines of class "A" will recognise that it is only reasonable to expect that as these classes of engines are employed most largely, so the number of derailments will be greater than in exceptional classes, where only few engines are employed.

The same remarks would apply to tender engines of the "I" class and tank engines of "L" class.

Diagram No. 5 shows that there have been ten cases in which the tender alone has been derailed.

Diagram No. 6 shows how many tender engines of the classes "A," "B," "C," etc., were derailed in each year.

Diagram No. 7 gives details of the number of tank engines derailed in each year.

Diagram No. 8 shows the total number of derailments during the twenty years ending December, 1904.

Diagram No. 9 shows the reasons which were given by the different Board of Trade inspectors as to why, in their opinion, the different classes of engine left the road. It will be observed by looking at this diagram that there were as many as sixteen cases of tender engines and eleven cases of tank engines which are said to have left the road for reasons connected with defective permanent way, including cases where points have been held over by stones; there is also one case with a tender engine, and one case with a tank engine, where oscillation is stated to have been

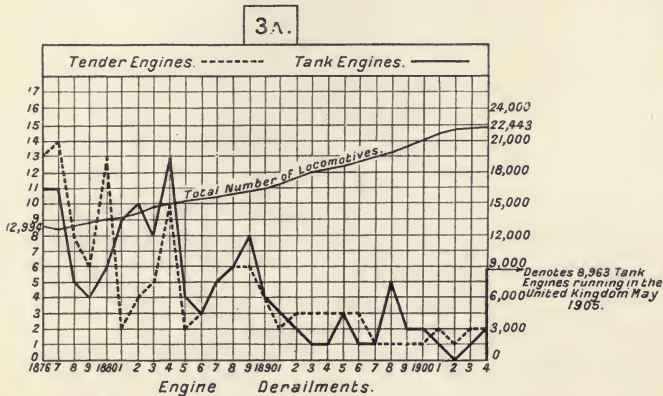

caused by defective permanent way, but there is not a single case where oscillation is said to have been caused by high speed.

The general effect of these diagrams is to show in the most conclusive way that derailments upon which the Board of Trade have considered it necessary to make a report during a period of twenty years became few in number, and that there is nothing whatever, when a close examination of the reports is made, to indicate that there is any greater danger with a tank engine than with a tender engine. On several of the largest railways in this country it has been found that no less than 50 per cent. of their total locomotive stock are tank engines, and that they run a large percentage of their high-speed passenger mileage, amounting in one case to 54 per cent., with engines of this class.

CHAPTER XXXVIII

LUBRICATION

It goes without saying that all rubbing surfaces in a locomotive engine must be well oiled. Various methods of lubrication are employed. The first and most simple consists in screwing on to the part to be lubricated a brass oil cup. Through the bottom of the cup descends a small brass tube, which rises nearly to the lid. Two or three strands of worsted, such as coarse stockings are made of, are put down the brass pipe like a wick. A bit of thin copper wire is twisted in with them and hooked over at the top end so as to prevent the wick falling down. It acts as a syphon, and delivers the oil from the box drop by drop until it is all gone. Sharp Brothers & Co., of the Atlas Works, Manchester, introduced nearly sixty years ago a very elegant system of lubrication. A long brass box was screwed at each side to the boiler near the smoke-box. From the bottom of the box six or eight small copper pipes were led to the slide bars, valve gear, &c. The pipes passed up through the bottom of the box and each was "trimmed" with a wick in the way just described. The box would hold a quart or more of oil. A stop cock was fitted to each leading pipe under the box, by which the quantity of oil distributed to each bearing was regulated. When a trip was over, or the engine had some time to stand, the fireman went out round the engine on the running board and closed all the cocks, thus effecting a great saving in oil. A precisely similar arrangement is used in torpedo boats and indeed on very many high-speed engines.

These methods are not applicable to what may be termed internal lubrication, as, for example, the working faces of slide valves. To the late Mr. Ramsbottom the world is indebted for

the first automatic arrangement for oiling valve chests. Fig. 90 shows the lubricator in diagram section. It consists of a strong brass vessel A, which can be screwed to the outside of the smoke-box B. A pipe C from the valve chest, fitted with a three-way stop cock, comes up through the bottom and reaches nearly to the top of the lubricator. E is a small brass funnel provided with a steamtight screwed plug. Nothing can be simpler. To use it the three-way cock is turned one quarter round, until the passage G is vertical. The contents of A will then be discharged at H. The plug at E is then removed, and the cock D turned until all the passages are blinded. The lubricator is then filled with oil up to such a point that it will just not run down the inner pipe. The filling plug is then replaced and the cock D is restored to the position shown in the diagram. As soon as steam is turned into the valve chest, it will also pass through the lubricating pipe into the lubricator, filling the small empty space I. It will there condense, and the heavy water sinking down through the light oil will displace the oil, which floats on it and overflows down through the steam cock and pipe G and so into the valve chest. The process is gradual, and by degrees all the oil is displaced, and the lubricator filled with water. Then the steam cock is shut off and the drain cock opened. The water is run out, and the lubricator refilled with oil.

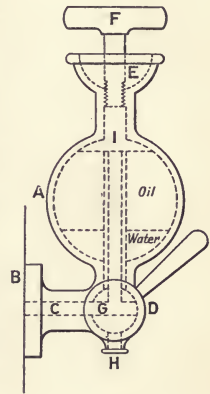

FIG. 90.

Ingenious and effective as this device is, it is very defective in certain ways. The rate of discharge from it depends largely on that at which steam condenses, and as there is no means of knowing when the oil is gone, without blowing the water out of it, it sometimes happens that all the oil disappears a great deal too soon. If the steam cock is partly closed to prevent this, then the oil may not go quickly enough to the rubbing surface. In modern engines, particularly those running long distances, oil is supplied by what are called sight feed

lubricators, which are fixed in the cab under the driver's eye. Short lengths of glass tube are full of water, up through which the drops of oil may be seen rising. There are, perhaps, fifty sight feed lubricators in the market, but they all depend for their action on either of two general principles. Either the oil is supplied under pressure by a small pump, or else the oil moves by displacement, as in the Ramsbottom lubricator just described. Small copper pipes lead the oil to the places where it is wanted. An exception is supplied by big ends and crank pins, which are always lubricated by hand. They are fitted with large oil boxes. The wick is, however, no longer a syphon, but a plug of worsted loosely coiled into a double copper wire and pushed into the pipe. In these rapidly moving parts, the oil would be jerked down the pipe, and the box emptied in a few minutes, if it were not checked by the worsted plug.

CHAPTER XXXIX

BRAKES

ALL locomotives in the present day are fitted with automatic brakes. These are rather complex systems of mechanism, and nothing more can be given here than a general description of them.

Up to about the year 1875 almost nothing had been done to improve on the very elementary screw brake on the tender and in the guards' vans, by which segments of wood were pressed against the tires to stop the train. These were very inefficient, and involved the expenditure of much labour on the part of the fireman and the guards. Besides the risk involved there was the serious delay incurred. Steam had to be shut off a couple of miles outside a station, and the train brought gradually to rest. Traffic involving frequent stops could not be conducted rapidly, because a train had scarcely got up speed before steam had to be shut off and the brakes applied. Many inventors attempted to produce something better than the screw brake, but the only successful attempt was that of Messrs. Newall and Fay. They put under the carriages a long shaft fitted with screws, which applied brake blocks to the wheels, and they coupled these rods end to end between the vehicles by a very simple universal joint. The effect was that the guard, instead of braking four wheels, only could brake a dozen. The invention was used with some success on the Midland Railway for several years.

To George Westinghouse, a young American engineer, is due the credit of first getting the Board of Trade and the Railway Companies to interest themselves in brakes. In 1875 a good deal of money was spent, and a most important trial of various

systems took place at Newark, under the presidency of the Duke of Buckingham. From this trial may be dated the ultimate adoption of the two systems in use to-day. The first is the pressure system, invented by Mr. Westinghouse, the second is the vacuum system, invented by Mr. Smith. The general principle is the same in both. A pipe extends from one end of the train to the other. Under the coaches this pipe is of iron, between them it is of india-rubber; each coach has its own length of hose, and these are coupled, when the train is made up, by a highly ingenious joint.

Under each coach are placed cylinders and pistons, the rods of which work cast iron brake blocks fitted to all the wheels.

Taking the Westinghouse brake first, the brakes are normally kept away from the wheels by springs. Under each coach is a small reservoir of air compressed by a pump on the engine, in a large drum, to a pressure of about 100 lbs. So long as there is an equal pressure in the train pipe and the reservoirs the brakes remain off. But each cylinder is fitted with what is known as the "triple valve." If now the pressure in the train pipe is reduced, by allowing air to escape from it, the triple valve moves at once and admits air from the small reservoirs to the brake cylinders. The pressure instantly applies the brake. If the train were to part in two, or an accident happened, the hose joint between the coaches would give way, the air would run out of the train pipe, and the brakes would be applied automatically. In regular work the driver is provided with a valve on the foot-plate by opening which he can permit the air to escape gradually from the train pipe. The triple valve will then move very slowly, and the pressure with which the brakes are applied can be regulated with minute accuracy. To take the brakes off, the train pipe is replenished from the main reservoir, which is in turn filled up again by the pump.

The vacuum brake is in all but details identical. Only the air in the train pipe and reservoirs is exhausted by an ejector on the engine, which works on the same principle as the blast pipe.¹ A vacuum is maintained on both sides of a piston,

¹ See page 151.

the rod of which is connected with the brakes. If now air is admitted to the train pipe, a valve moves and air gets into the cylinder, and pressing with a force of 15 lbs. on the square inch at one side, while it is only resisted by a comparatively small pressure at the other side, the brakes are put on. The action is controlled from the footplate by a valve as already described. Both systems have been made the subject of many patents.

In some cases the vacuum is maintained by a pump worked off a cross head or some other part of the engine. It has been found impossible to prevent leakage altogether; at first all engines were provided with a large and a small ejector. The large one established the vacuum, and the small one maintained it. After a time, however, it was found that the small ejector wasted much steam, and the pump was substituted with quite satisfactory results.

CHAPTER XL

THE RUNNING SHED

UNDER this comprehensive title will be considered what may without inexactitude be termed the hidden life of the locomotive engine. It is not always drawing trains, it is not always being repaired or repainted. As a horse spends much of his time in the stable, so does the locomotive in the running shed, which has, indeed, not inaptly, been termed a stable ere now.

Originally there was provided a shed, literally a shed and nothing more, in which the engines stood when not at work, and in which they were cleaned and had small repairs effected. For many years and in the present day, a running shed is a large and important building, often provided with tools, and in which all but very heavy repairs can be effected. Turntables are arranged and many lines of rail with pits between to enable men to work conveniently under the locomotives.

There are various methods of laying out a running shed, which, by the way, is called a "round house" in the United States. Thus the general plan may be circular with a turntable in the middle, from which radiate lines of rail like the spokes of a wheel. When an engine comes in it is run on to the turntable, which is rotated until its rails coincide with a "spoke" on which there is room. The engine is then run off the turntable on to the spoke. The arrangement is very convenient, but has the serious drawback that if anything fouls the turntable all the locomotives in the shed are imprisoned for the time being—an accident by no means unknown, and commonly brought about by moving an engine when the rails on the table are not in line with those of the spoke. Then the leading wheels of the engine drop into the turntable pit. A much safer system consists in providing a

number of bays and shunting an engine into any bay by means of points. More space is required, but the gain fully compensates for the extra cost incurred.

The running sheds are placed in localities as convenient as can be got near large towns. They vary in the amount of accommodation they supply from holding half a dozen to a hundred engines.

On the care and skill with which the duties of the running-shed foremen and the hands under them are carried out depends in very large measure the satisfactory and economical working of the traffic of a railway. To mention only one point, the durability of a boiler is settled in the main by the way in which it is cleaned. If that is badly done, the boiler will steam badly, use more coal than it ought, and fail to keep time.

Let us take the case of an express engine, which has finished its work for the day. It is unhooked from its train, and taken to the running shed. The duty of the driver before handing it over to the "engine turner," a man whose position resembles that of an ostler, is to examine the engine carefully and book all the defects he discovers. The turner then moves the engine to the coaling stage, the fireman locks up his tool chest and chinks on one of the boxes how much coal he requires for his next trip. The engine is, save under most exceptional circumstances, to be brought to the end of its journey with little or no fire on the grate. After the tender has received the stated number of tons of coal, the engine is moved to another part of the yard, and the smoke-box is cleaned out. As has already been explained, the box is floored with fire-bricks laid in fire-clay, and on this will be found collected ash and cinders which have been carried through the flues. A spray from a hydrant is used to keep down dust, and the box is cleared out by a lad with a shovel and broom. The engine, which has still steam in it, is then moved once more to stand over a pit, where two "fire droppers," one on the footplate and the other under the engine, take charge. Then some fire bars are lifted out, and through the space thus left, ash, cinders and clinkers are dropped into the ash pan by the man on the footplate, while his mate below rakes them out into the pit where

they are sprayed by a hose pipe. In this operation, simple as it seems to be, we have another illustration of the importance of doing things in the right way. It seems quite obvious that it would be far better to make the grate invariably—as is done sometimes—with a hinged portion at the front end to which the bars always slope, rather than adopt the clumsy system of pulling two or three or more bars out. But the drop grate system has the great defect that if it is used while the boiler is still hot, and a rush of cold air into the fire-box takes place, contraction occurs and the tubes leak. Indeed, in some running sheds, fire dropping is not permitted while a boiler is hot, and the grate has to be cleaned through the fire door; but the operation lasts about half an hour, and the time is not always available. The tubes are then “run”—that is, swept out. A long rod about $\frac{3}{8}$ inch diameter with an eye at the end is used. Through the eye is threaded a strip of canvas or old “waste.” The smoke-box door is opened and a man standing on the front running board pushes the rod through one tube after another. In this way the tubes are swept. The operation lasts from forty minutes to an hour, according to the number of tubes. A steam jet at the end of a hose has been tried with great success, much time being saved.

The cleaners then take the engine in hand. It is rubbed down with sponge cloths and “cleaning oil,” that is, petroleum. The cleaners are boys or lads. Cleaning is the first step on the way to be an engine driver:

Round the ends of the tubes next the fire-box rings of coke deposit (due to the presence of minute percentages of iron in the coal) form and encroach on the size of the orifice. A boy goes into the fire-box with a stiff broom and knocks off the “corks,” as they are called—they are termed “birds’ nests” at sea; they very closely resemble india-rubber umbrella rings. He then sweeps the ashes off the top of the brick arch, and replaces the fire-bars. The engine is then ready to have steam got up again. The “lighter-up” puts coal into the box, spreading it carefully all round the sides.

Conveniently situated is a brick furnace of considerable size. On the top of this sand is dried which is subsequently put into

the sand boxes on the engine and used for increasing adhesion, as already explained. On the Great Western Railway an improved furnace is used. The wet sand is put into a chamber with a grated bottom over the horizontal flue leading to the chimney, and as the sand dries it falls automatically through the hot gas and flame. About five times as much sand can be dried in a given time in this way as by the ordinary furnace.

From this furnace some shovelfuls of burning coal are carried and put into the fire-box, and so lighting up is effected. As the fires are not to be hurried, which would be bad for the boilers, it requires about three hours to get up steam; and the fire is usually lighted about four hours before the time at which the train starts. While in the shed the fireman takes in water and fills the sand boxes. The driver goes over the whole engine with minute care, examining every split pin, nut and bolt, knowing, as he does, that his own life and the safety of the train depend upon his vigilance.

It has been assumed that the engine requires neither washing out nor repairs. But washing out must take place every five or six days. To this end, the engine is allowed to cool down, then the plugs at the lower corners of the fire-box are unscrewed, and the water is allowed to run out. All the other wash-out plugs are removed, and the boiler is then cleaned out by the use of a jet, by preference of hot water, the nozzle being put into one plug hole after another. While one man uses the hose, another works with a rod to scoop out and loosen all the deposit he can get at. The boiler is then examined, preferably by a boilermaker. If he pronounces it clean the plugs are oiled with some heavy oil and screwed in again. The boiler is filled up with fresh water by a hose through one of the upper plug holes. Washing out is a very important operation. A book is kept in which are entered under separate heads, date, station, number of engine, name of washer, by whom examined, and remarks as to dirt. When tubes leak, neglect in washing out is always assumed as a probable cause.

While in the running sheds that careful inspection takes place which renders the explosion of a locomotive boiler an event of

the rarest occurrence. Practice varies, but it is not far from the truth to say that more than a month seldom elapses without an examination of a very thorough character being made by a boiler-smith. As a rule there is little trouble with the shells; grooving and corrosion are rare, and are detected when the lagging is taken off and tubes drawn for a thorough repair, which will not be needed as a rule for three or four years. But the fire-box is a continual source of anxiety. The wear and tear have been much increased by the rise in pressure. Boxes which give little or no trouble with 150 lbs. steam require the utmost vigilance to make them endure 200 or 220 lbs. pressure. The higher the pressure the denser becomes the deposit and the more firmly does it cling to the plates. A fairly soft water is essential to the well-being of the modern locomotive. The most common defects in a copper internal fire-box are cracks. The examiner has a special book in which he records in a species of shorthand all the defects which he finds. A great deal of information is got into a small space by a system of hieroglyphics. As an example of the progress of events in the life of a locomotive boiler, the following statement is given:—

“ Nothing of note occurred to the box during that year, but on January 13, 1904, the stay heads were slightly reduced. Fifteen new stays were put in on January 27, 1904. The stays were reported reduced on April 19, and on May 12 a crack had developed in the right-hand flange of the tube plate; also, the top flange of the back plate had dropped down near the second crown bars. On August 23 the tubes were dirty, and the casing plates were corroded near the foundation ring. On August 30, 1904, eighty-four new tubes were put in to replace those taken out to facilitate the removal of dirt, and this time also the sides were found to be slightly bulged. Twelve more stays were put in on April 11, 1905, and on September 12 another crack had developed in the tube plate, this time in the left-hand flange, and the sides which had been previously reported as “slightly bulged” were reported as “bulged.” On October 17, the tubes were again reported dirty, and after the engine had been kept running as long as it consistently could be in this

condition, it was sent to the factory for general repairs on January 31, 1906.”

The preceding quotation is taken from a paper read before the Swindon Engineering Society by Mr. Henry Simpson, of the Great Western Railway.

It must, of course, be understood that running-shed work is not carried on in the same way on all railways. No more can be done than give the general arrangements and methods adopted. Thus, for example, on some lines it is the practice to coal the engines after they have been cleaned and left the running shed, but in effect practice is the same everywhere.

A locomotive is not cleaned after every trip as described above. Slag is taken off the grate by the fireman, and the tubes are run and the smoke-box cleaned out, but steam is not let down below 80 or 100 lbs. pressure, and a fresh supply of coal is, if needed, put on the tender.

The day's work of an engine is very often worked out as though it had been running steadily from the time steam was got up until it returned to the shed. The mileage varies with the railway, the time of the year, and traffic conditions. At one time on the London and Brighton line it was four miles an hour for goods and about eight miles an hour for passenger engines. A goods engine, for example, will be under steam and out on the road for say, fourteen hours. Of that time, five hours will be spent standing still. Two or three hours will be used up at different stations shunting, the whole distance traversed being quite small. The rest of the time the engine will spend in hauling heavy trains at, say, twenty miles an hour.

The average annual mileage of engines in this country is about 20,000. Of course to this there are numerous exceptions, the mileage being much greater. Individual engines sometimes make enormous mileages. In the United States it is very much higher, but as a result the total life of the engine and the number of miles run is less. The American locomotive is treated very much on the principle followed by Legree with his slaves, “use up and buy more.”

CHAPTER XLI

THE WORK OF THE LOCOMOTIVE

WE have now to consider the work of a locomotive—the duty which a machine so ingenious, so complex, and so carefully and cautiously developed has to perform.

In one sense this admits of being very easily stated. The business in life of the locomotive is to pull. Its value from the railway companies' point of view is estimated in terms of this central fact—a fact which must be carefully kept in mind. All the various devices for securing power and economy have, after all, no other ultimate object than the securing, other things being equal, of the greatest possible tractive effort for the smallest outlay of money. At first sight it might appear that speed is an important element in our calculations. It will, however, be seen presently that speed itself depends on tractive effort. Once more, other things being equal, the engine which can pull hardest will run fastest. Now the drawbar pull will always be precisely equal to the reaction of the wheels at the points where they rest on the rails, less the amount required to overcome the rolling or road resistance of the engine and tender. Deducting this last we have the net pull on the hook at the back of the tender left for drawing the train.

The precise way in which the engine is propelled has already been fully explained on page 66, but this has nothing whatever to do with the action of the wheel on the rail as a fulcrum. The wheel continually tries to push the rail backwards, and failing in this it rolls forward, and with it the engine and train. We have then, before we can arrive at any just estimate of the hauling power of a locomotive, to ascertain what this power may be. It is always calculated by a formula for which the world is indebted

to the Chevalier F. M. G. De Pambour, a young French engineer, who carried out a remarkable series of experiments on the Liverpool and Manchester Railway. The results took the form of a treatise published first in France in 1835. Subsequently an excellent translation was published in English, in Philadelphia in 1836.

The formula is very simple:—

Let D be the diameter of the driving wheel in inches.

„ d „ diameter of the cylinder in inches.

„ L „ length of stroke.

„ P „ average effective pressure in the cylinder in pounds per square inch.

Then $\frac{d^2 \times L \times P}{D} = T$, the tractive effort.

Only one cylinder is to be taken; usually P is taken as unity. The result of the calculation is the tractive effort with a cylinder pressure of one pound, which can be regarded as the coefficient for the engine. Thus, let $T =$ tractive power.

$$D = 60; \quad d = 20.$$

$$L = 24 \text{ and } P = 1.$$

Then $T = \frac{400 \times 24}{60} = 160$ lbs. This is the tractive effort at

the points where the driving wheels touch the rails for every pound of average effective pressure in the cylinders. It is divided up among the wheels; if there are two driving wheels, then it is 80 lbs. each; if four, 40 lbs. each, and so on.

For compound locomotives, the formula becomes

$$T = \frac{1.6 P r^2 L}{D (2 + 1)},$$

where $T =$ tractive power, $d =$ diameter of low pressure cylinder, $L =$ length of stroke, r the ratio of the cylinder volumes, and $D =$ the diameter of the driving wheels. Normally, a deduction of 20 per cent. is made in all cases to cover the resistance of the engine and tender, that is to say, the rolling or road resistance.

As the formula puzzles the student in some cases, because only one cylinder is taken although there are two, the following

passage is reproduced from Pambour's book, which explains how he obtained it.

"If we find that the steam by causing a known effective pressure per square inch can make the engine advance, the area of the two pistons in square inches being known, it is easy to calculate the total force applied by the steam on those two pistons. That force being sufficient to make the engine advance—that is to say, to conquer its resistance—it gives, of course, the value of that resistance.¹ It must only be observed according to the principle known in Mechanics by the name of "The Principle of Virtual Velocities," that the pressure exercised on the part of an engine being transmitted to another part of the same engine retains the same intensity only in case the two parts have the same velocity. If not, the force of pressure is reduced in an inverse ratio to the velocity of the points of application. This principle appears in an evident manner, and *à priori* in simple machines like the lever, the roll, the pulley, and an inspection alone is sufficient to demonstrate that, if a force can by the aid of the machine raise a weight four times as great as itself, it is only by travelling in the same space of time four times as far as the weight which it raises. In the case before us the velocity of the piston is to that of the engine as twice the stroke is to the circumference of the wheel, the piston giving two strokes while the wheel turns once round. A force applied on the piston produces therefore in regard to the progress of the engine an effect reduced in the same proportion, that is to say, as twice the stroke is to the circumference of the wheel.

"Let d be the diameter of the piston, and π the ratio of the circumference to the diameter, $\frac{1}{4} \pi d^2$ will be the area of one of the two pistons, and P being the effectual pressure of the steam per square inch, then $\frac{1}{2} \pi d^2 P$ will be the effective pressure upon the two pistons. If, moreover, l expresses the length of the stroke,

¹ It is worth notice that this appears to be the first recognition of the fact that there is no such thing as an unbalanced force. Previously, and for many years subsequently, it was always taken for granted that unless a force exceeded the resistance there could be no motion; that the resistance of a train was always less than the pull of the engine, the resistance to a piston less than the pressure on it.

and D the diameter of the wheel, the effective force of transfer resulting to the engine in consequence of that transfer will be

$$\frac{1}{2} \pi d^2 P \times \frac{2 l}{\pi D} \text{ or } \frac{p l d^2}{D},$$

which, according to what we have said, gives the measure of the resistance of the engine."

It must be understood that the word "resistance" refers here to the rolling and not to the frictional resistance of the locomotive. In other words, the equation gives the tractive effort.

A little thought will suffice to show that there must be some definite speed which, multiplied by the drawbar pull, will give maximum efficiency. The pull steadily falls off as the speed increases, because the average effective pressure diminishes, partly because of wire drawing and partly because the boiler cannot make enough steam. What this speed will be depends on various conditions. It is known as the critical speed, and is in all cases comparatively low. It is impossible to go fully into the question here. But something must be said in the way of explanation. Professor Goss's investigations go to show that it is always about 200 revolutions per minute, no matter what the size of the driving wheel (*vide* page 301).

The question of train resistance has been made the subject of most elaborate and costly investigation, and even yet it cannot be said that conclusive results have been obtained. Nothing more can be done here than give three formulæ. The first has been obtained by Mr. Deeley, on the Midland Railway :

$$R = 3.25 + \frac{V^2}{281}.$$

The second is by M. Laboriette, a French engineer :

$$R = 3 + \frac{V^2}{290}.$$

These do not apply to speeds below twenty miles an hour, when the resistance of the axle is higher than at quick speeds. The following formula of general application to all speeds has been prepared by Mr. Wolff :

$$R = 3 \left(\frac{V + 12}{V + 3} \right) + \frac{v^2}{300}.$$

Owing to the great weight and enormous momentum of a locomotive, it might be supposed that its drawbar pull would be perfectly steady, but it is not. It will be remembered that not all the reciprocating motion can be counterpoised, and there are besides the internal disturbing forces due to the varying crank moments and piston pressures. On the testing plant at the St. Louis Exhibition, to which reference has already been made, the locomotives pulled on a tractometer, which, being fitted with a recording pencil, gave a diagram of the pull.

Three tractometer diagrams have been selected from a considerable number, and are here given; they are from "Locomotive

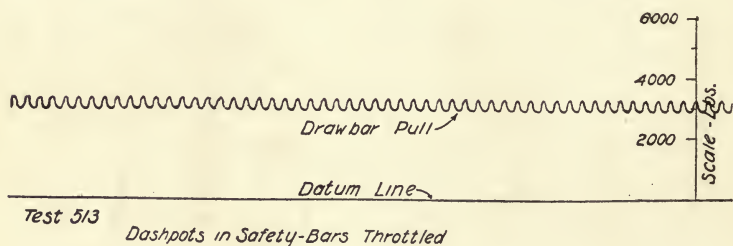

Speed, 66.96 Miles per Hour.

FIG. 91.

Tests and Exhibits." Fig. 91 is from a De Glehn compound four-cylinder engine very similar in all respects to La France, which attracted much attention when first put to work some three years ago on the Great Western Railway. The amount of the pull in pounds is shown at the right-hand end of the diagram, which it will be understood is a portion of a continuous trace made on a strip of paper moving under a pencil. The form of the trace is somewhat modified by the action of two dash pots placed at the anchorage. The levelling effect of four cylinders is manifested. The difference in pulls does not much exceed about 300 lbs.

The diagram, Fig. 92, is one from a very heavy "simple" freight engine, with eight wheels coupled 53 inch diameter, two cylinders 21 inches \times 30 inches. It will be seen that at fifteen miles an

hour the maxim pull reached about 22,000 lbs., the difference in pulls being as much as 1,500 lbs. The third diagram is from

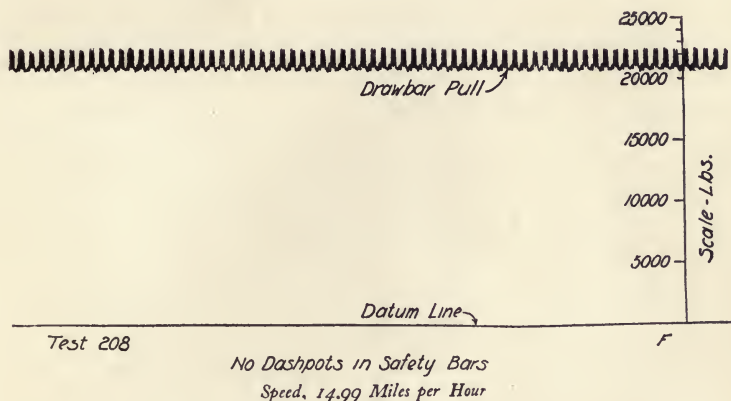

FIG. 92.

the same engine at a little under thirty miles an hour; the average pull has fallen to 10,000 lbs., but the difference between the highest and the lowest is now about 2,100 lbs. The causes

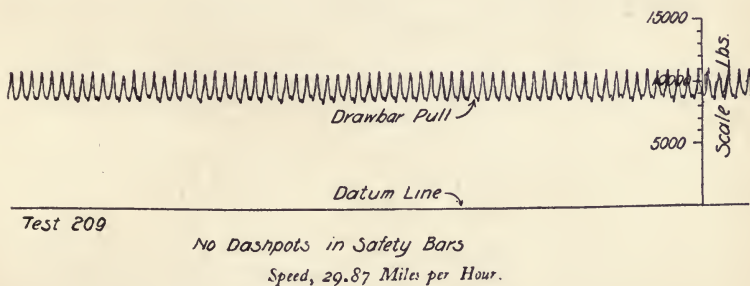

FIG. 93.

of the vibration have already been explained. It will be understood that each "saw tooth" stands for one complete revolution of the driving wheels. The total motion of the draw bar did not exceed 0.04 inch, so that a locomotive exerting a drawbar pull

equal to the full capacity of the dynamometer¹ did not move forward on the supporting wheels more than this amount. The motion was increased 200 times at the recording pen, or for each one hundredth of an inch that the locomotive moved forward the recording pen moved through a space of two inches, the total movement being 8 inches for the 0·04 inch movement.

It might be supposed that when the engine is drawing a train its own momentum would extinguish the vibration, but in point of fact it does not, and the trace taken in a tractometer van is very similar in character to that obtained in the test house.

The actual performance of locomotives is very varied. A complete record of all that has been noteworthy in this country and in France has been supplied periodically for several years past to the *Engineer* by the late Mr. Charles Rous Marten, which record will be found most interesting reading.

Much is heard now and then about trains making up lost time, and drivers are censured by the public for incurring risks; but as a matter of fact, it is extremely difficult, particularly with fast trains, to make up lost time. Mr. Ivatt several years ago prepared a very useful diagram, Fig. 94, which sets this truth in a very clear light.

As an example, if a train running at sixty-five miles per hour has lost a minute, it has to run fifteen miles at seventy miles per hour in order to make up that minute, showing prominently what a great length of line must be run over in order to make up even so small an amount of time as one minute.

The diameters of the driving wheels of all but the smallest locomotives, such as those used by contractors and in engineering and iron works, vary between 4 feet and 8 feet. Goods engines have driving wheels as a rule not often less than 4 feet 6 inches or more than 5 feet 6 inches. Passenger engine driving wheels are in the present day 5 feet 6 inches to 7 feet 9 inches diameter. No engines are now being made with 8-foot wheels, but a few are still running. Very early in the history of railways it came to be understood that large diameters and speed went together,

¹ This is the recognised term, but as it may cause confusion the author prefers to use the word "tractometer," about which no mistake can arise.

but about the precise reason why no one was troubled. Indeed, it was not till some ten years ago, when Professor Goss, of Purdue University, U.S.A., undertook his investigations, that the facts were reduced to a sound numerical basis.

The steaming power of the boiler is the final measure of that of the whole machine. It may be taken as proved that a locomotive boiler may be depended upon to evaporate 12 lbs. of water per square foot of heating surface per hour. Thus a boiler with 1,300 square feet will make 15,600 lbs. of steam per hour.

Now the dimensions of cylinders are fixed by conditions which have been fully explained in preceding pages. It will be seen at once that whether the full power of the boiler is or is not to be utilised depends on how many times each cylinder can be filled and emptied in a minute. Suppose that our cylinders are too small, then let us run the engine faster. But the speed of the

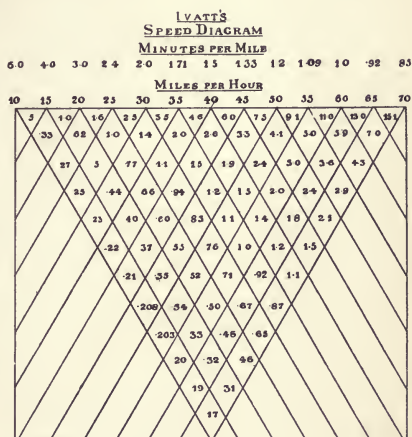

FIG. 94.

train is fixed by traffic managers. Let us meet this objection by reducing the diameter of the driving wheels. But this will not do for reasons already explained. Wire drawing steps in, the consumption of steam per stroke falls off, and so does the mean effective cylinder pressure. If the horse power of the boiler is a constant, then T S will also be a constant. Here T is the tractive effort and S the speed in miles per hour. That is to say, the tractive effort will fall off as the speed augments, and a curve plotted for various speeds and tractive efforts is a hyperbola. The tractive effort depends on the mean pressure in the cylinder, and that may be so much reduced by wire drawing that an engine with small wheels may be quite unable

to use up all the steam the boiler can make, and so actually exert less pull than an engine with larger wheels. If the reader will follow this reasoning out he will find that for normal locomotives about 200 revolutions per minute, or 800 strokes for the two cylinders, may be regarded as the limiting condition for the exertion of maximum drawbar pull. In other words, $T S$ then represents the maximum power which the engine can exert. If this is so, then if 30 miles an hour corresponds with 200 revolutions per minute, 60 miles an hour will demand driving wheels of twice the diameter. One eminent builder of locomotives in the United States holds that driving wheels should have one inch diameter for every mile an hour of maximum speed. But this gives a 5-foot wheel for 60 miles an hour, which is much too small.

To make this reasoning clearer, the following experiment is quoted from Professor Goss's book "Locomotive Performance." "A particular engine, with a nominal cut-off at 35 per cent. of the stroke, when making 188 revolutions per minute, had a mean effective cylinder pressure of 42.4 lbs. and the tractive effort $T = 4,639$ lbs. But to run this engine at 55 miles an hour and 296 revolutions per minute the mean pressure, the nominal cut-off remaining unaltered, fell to 27.4 lbs. and the tractive effort to 2,997 lbs. The wheels were 5 feet 3 inches in diameter. If they had been increased to 8 feet 3 inches the speed would have been 55 miles an hour, the revolutions 188, and $T = 2,943$ lbs., the loss in tractive effort due to this increase in the size of the driving wheels being almost entirely compensated by the maintenance of a high mean cylinder pressure."

It must not be forgotten, however, that the engine with the big drivers would start very badly as compared with that with the small wheels.

Enough has been said to show that the determination of the diameter of driving wheels to give the best results is a very delicate point. The facts go far to explain why it is that small differences in the diameters of driving wheels may produce results apparently out of all proportion to the differences.

There is apparently no limit to what might be said about the railway locomotive. The book to which these words form the conclusion deals with many subjects, each and every one of which might well receive fuller treatment. The locomotive grows with the growth of nations; it has been a principal agent in the extension of civilisation. To it is due the modern great city and the spread of commerce. No other machine is so ostensible; it is always before the public. No other is more flexible or ready to render service under most varying conditions, probably none other does so much useful work. It is the only machine that appears to be alive. It is almost impossible indeed to watch one start its train or thunder through a station and escape the sensation that we have a sentient being in evidence. It has been said that electricity will supersede it. Possibly, but the time is not near. Whenever and wherever, the locomotive engine will still remain immortal. Its history may indeed be forgotten or overlooked by future generations. But among those who admire and love mechanism and the mechanical arts will always be found a few who will keep its memory green, and that of the men to whose genius, talents, and indomitable energy the world is indebted for the most wonderful machine ever devised.

STANDARD WORKS ON THE LOCOMOTIVE ENGINE

A Practical Treatise on Railroads and Internal Communications in General. By Nicholas Wood. London: Longman. 1832.

A Practical Treatise on Locomotive Engines upon Railways. By the Chevalier F. M. G. De Pambour. Philadelphia: Carey & Hart. 1836.

The Machinery of Railways. By D. K. Clark. 1855.

On Heat and its relation to Water and Steam. By Charles Wye Williams. Longman. 1860.

The Internal Disturbing Forces of the Locomotive. By J. Makinson. Trans. Inst. C. E. 1862.

Locomotive Engineering and the Mechanism of Railways. By Zerah Colburn, completed by W. H. Maw and D. K. Clark. Glasgow: William Collins. 1864.

Experimental Researches in Steam Engineering, Vol. II. By Benjamin Isherwood. Philadelphia: Franklin Institute. 1865.

Treatise on the Locomotive Engine. By G. D. Dempsey. Weale's Series. London: Crosby Lockwood & Co. 1879.

The Construction of Locomotive Engines. By W. Stroudley. Trans. Inst. C. E. 1885.

Counterbalancing Locomotives. By Edmund Lewin Hill. Trans. Inst. C. E. 1891.

The Construction of the Modern Locomotive. By George Hughes. London: E. & F. N. Spon. 1894.

Valves and Valve Gearing. A practical text-book, by Charles Hirst. London: Charles Griffin & Co. 1897.

The Evolution of the Locomotive Engine. By W. P. Marshall. Trans. Inst. C. E. 1898.

The Steam Engine Indicator. By Cecil H. Peabody. New York: John Wiley & Sons. 1900.

Locomotive Operation. A Technical and Practical Analysis. By G. R. Henderson, M.A.S.M.E. Chicago: *The Railway Age*. 1904.

The Pennsylvania Railroad System at the Louisiana Purchase Exhibition. Locomotive Tests and Exhibits, St. Louis, Missouri, 1904. Philadelphia: The Pennsylvania Railroad Co. 1905.

La Locomotive Actuelle. Etude Générale sur les Types Récents des Locomotives à Grande Puissance. Par Maurice Demoulin, Ingénieur de la Traction, Chemin de fer de l'Ouest. Paris: Beranger. 1906.

Die Dampflokomotiven der Gegenwart. Ein Handbuch für Lokomotivbauer. Eisenbahnbetriebsbeamte und Studierende des Maschinenbaufachs. Von Robert Garbe, Geheimen Baurat, Mitglied der Kgl. Eisenbahndirektion, Berlin. 1907.

Locomotive Performance. The Result of a Series of Researches conducted by the Engineering Laboratory, Purdue University, U.S.A. By W. F. M. Goss, M.S. New York: John Wiley & Sons. 1907.

Bulletin of the International Railway Congress. English edition, published monthly. London: King & Sons.

The Locomotive Catechism. By Robert Grimshaw. New York: Norman W. Henley & Co. London: E. & F. N. Spon. 1893.

Train Resistance. By J. A. F. Aspinall. Trans. Inst. C. E. 1901.

History of the Furness Railway. By W. F. Pettigrew. Trans. Inst. Mech. Eng. 1901.

Recent Locomotive Practice in France. By Edouard Sauvage. Trans. Inst. Mech. Eng. 1900.

Experiments on the Draught produced in different parts of a locomotive boiler when running. By J. A. F. Aspinall. Trans. Inst. Mech. Eng. 1893.

Superheaters applied to Locomotives on the Belgian State Railways. By M. J. B. Flamme. Inst. Mech. C. E. 1905.

Large Locomotive Boilers. By George Churchward. Trans. Inst. Mech. Eng. 1906.

Ten Years of Locomotive Progress. By George Montagu. London: Alston Rivers. 1907.

Modern Locomotive Practice. A treatise on the design, construction and working of Steam Locomotives. By C. E. Wolff, B.Sc. Manchester: Scientific Publishing Co. 1907.

Lectures delivered to the Enginemen and Firemen of the London and South Western Railway Co. on the Management of their Engines. By D. Drummond, C.E., Chief Mechanical Engineer. London: Waterlow & Sons, Ltd. 1907.

INDEX

A.

ACCELERATION, 273
Action of the bogie, 27
Adams' elastic wheel, 54
,, vortex pipe, 145
Adhesion, 55, 58
Adjustable blast nozzle, 146
Ashpans, 108
Automatic expansion, 255
,, lubricator, 283
Axle journals, 4
,, box, 5

B.

BACK pressure, 138
Balance valves, 238
,, weights, 79
Baldry's rule, 25
Baldwin smoke-box, 150
Bar frames, 7
Barrus calorimeter, 164
Belgian locomotives, 119
Belpaire fire-box, 103
Birds' nests, 128
Bissell bogie, 15
Blast pipe, 143
Board of Trade rules, 93
Bogie springs, 29
Bogies, 15
Boiler fittings, 180
Boilers, 85
Boring cylinders, 203
Brakes, 285

Bridles, 237
Buffers, 37
Built-up crank axles, 211
Bushed small ends, 208

C.

CATARACT, 229
Centrifugal force, 30
Chimney, 146, 147
Circulation, 156
Cleaning engines, 289
Clinkering, 128
Coal, 127
Co-efficient of adhesion, 59
Coke, 124
Collision at Bina, 271
Combustion, 120
Compensating levers, 11
,, weights, 78
Compounding, 239
Connecting rod, 204
Constant lead, 235
Contact area, 56
Cost of superheaters, 262
Counterbalancing, 73
Coupled wheels, 60
Couché and Havrez's experiments, 133
Crank axles, 209
,, pin friction, 210
Crossed and open rods, 225
Curves, 13
Cylinders, 202

- D.
- DE PAMBOUR's formula, 295
- Derailments, 1, 27
 „ of tank engines, 277, 281
- Design of boilers, 114
- Development of bar frame, 9
- Diaphragm, 139
- Distribution of heat, 88, 89
- Disturbing forces, 2
- Diverging nozzle, 191
- Domes, 115
- Draught, 131
- Drawbar pull, 298
- Drummond's feed-water heater, 269
 „ water tubes, 117, 118
- E.
- ELASTIC roads, 83
- Engine mileage, 293
- Exhaust steam, 123
- Expansion, 217
 „ of copper, 105
- Explosions, 89
- F.
- FAY's brake, 285
- Finding centre of gravity, 274
- Fire boxes, 95, 102
 „ holes, 107
- Firebrick arch, 124
- Firing locomotives, 129
- Flanged steel bogies, 19
- Flanging press, 18
- Floating lever, 230
- Flue tubes, 109, 110
- Foundation ring, 106
- Four-cylinder engines, 246
- Frames, 1
- Friction, 209
- Front end, 136
- Fuel, 127
- G.
- GAB gear, 214
- Girder slings, 105, 107
- Glass water gauge, 186
- Going blind, 221
- Grate bars, 108
- Gravity, centre of, 34
- Great Eastern Railway bogie, 20
- Great Liverpool, 38
- Great Northern pony, 16
 „ „ bogie, 17
- Great Western Railway bogie, 21
- Guide bars, 204
- H.
- HAMMER blow, 79
- Heat pegs, 154
- Heating feed water, 161, 265
- Horn plates, 11
- Howe's valve gear, 215
- Hull and Barnsley Railway, 99
- Hydrokineter, 155
- Hyperbolic logs, 219
- I.
- INDICATORS, 251
- Initial condensation, 253
- Injectors, 187
- Intercepting valves, 244
- Intermediate receiver, 242
- Internal disturbing forces, 66
- Ivatt's experiments, 257
 „ speed diagram, 301
- J.
- Joy's radial gear, 213, 233
- K.
- KRUPP's disc wheels, 44
- L.
- LA FRANCE, 137
- Lagging, 196
- Lap, 220
- Lead, 220
- Length of flame, 135

Lifting action of cross head, 71
 Lighting up, 291
 Long grates, 117
 Longitudinal seams, 94
 Loss by radiation, 177
 Lubrication, 282
 Lurching, 37

M.

MARRIOTTE'S law, 252
 Mass, 29
 Maximum drawbar pull, 302
 Mineral oils, 260

N.

NOTKIN superheater, 177
 Nozzle, 143

P.

PALLISER bolts, 96
 Peabody calorimeter, 165, 166
 Pet cocks, 185
 Petticoat pipes, 146
 Pick-up scoops, 264
 Pielock superheater, 177
 Pistons, 212
 Piston valves, 246
 Plate frames, 3
 Pop valves, 185
 Priming, 162
 Propulsion, 66
 Purdue University, 81

Q.

QUALITY of steam, 169

R.

RAMSBOTTOM safety valves, 184
 Range of temperature, 254
 Rankine's formula, 74
 Rate of combustion, 130
 ,, evaporation, 132

R.L.

Ratio of expansion, 241
 Reciprocating masses, 76
 Reversing lever, 225
 Rolling, 71
 Running shed, 288

S.

SAFETY valves, 183
 Sanding rails, 64
 Schenectady No. 1, 136
 Schmidt's superheater, 174, 175
 Screwed stays, 95
 Self-starting injectors, 194
 Shrinkage, 45
 Side rods, 61, 62
 Sight feed lubricators, 284
 Simple steam engine, 199
 Slide valves, 236
 Slipper guide, 206, 207
 Smith's piston valves, 247
 Smoke-box, 137
 ,, L. & S. W. R., 140
 ,, S. E. & C. R., 141, 142
 Springs, 11
 Standard front end, 149
 Staybolts, 97
 Steam, 86, 152
 Steam gas, 260
 Stephenson's frames, 6
 ,, link motion, 213, 223
 Stirling's express engine, 23
 Stresses in boilers, 91
 Stuffing box, 203
 Super-elevation, 36
 Superheating, 171

T.

TANK engines, 271
 Temperatures, 132
 Tenders, 263
 Testing plant, 80
 The locomotive as a steam engine,
 198

Y

The locomotive as a steam generator,
 84
 „ „ as a vehicle, 1
 Theory of the blast pipe, 151
 „ „ injector, 189
 Throttle valves, 180, 181
 Tire dimensions, 48, 49, 50, 51
 „ rolling mill, 41
 „ sections, 46, 47, 52
 Tires, 40
 Train resistance, 297
 Transmission of heat, 153
 Traversing axle, 24
 Treatment of water, 159
 Tube expanders, 111
 „ leakage, 112

V.

VACUUM brake, 286
 Valve gear, 213

W.

WAINWRIGHT's reversing gear, 226,
 227, 228
 Walschaert's gear, 213, 230
 Wandering, 70
 Washing out boilers, 291
 Wasting of stays, 101
 Water, 159
 Water legs, 157
 „ spaces, 116
 Water-tube boilers, 170
 Wear of cylinders, 202
 Webb's whirling table, 44
 Weights of boilers, 113
 Westinghouse brake, 285
 Wheel base, 13
 Wheel and rail, 54
 Wheels, 40
 Wire drawing, 255
 Work of injectors, 193
 „ the locomotive, 294
 Wrought iron wheels, 43



